

UNCLASSIFIED

AD 464305

DEFENSE DOCUMENTATION CENTER

FOR

SCIENTIFIC AND TECHNICAL INFORMATION

CAMERON STATION ALEXANDRIA, VIRGINIA



UNCLASSIFIED

NOTICE: When government or other drawings, specifications or other data are used for any purpose other than in connection with a definitely related government procurement operation, the U. S. Government thereby incurs no responsibility, nor any obligation whatsoever; and the fact that the Government may have formulated, furnished, or in any way supplied the said drawings, specifications, or other data is not to be regarded by implication or otherwise as in any manner licensing the holder or any other person or corporation, or conveying any rights or permission to manufacture, use or sell any patented invention that may in any way be related thereto.

AD

CATALOGED BY: DDC  
AS AD NO. 464305

464305

REPORT NO. RR-TR-65-6

POLYNOMIAL GAS FLOW REGULATORS

By

T. A. Barr and R. F. Mayo

MAY 1965



DDC  
 RECEIVED  
 JUN 10 1965  
 RESOLVED  
 DDC-IRA E

**DDC AVAILABILITY NOTICE**

**Qualified requesters may obtain copies of this report from DDC.**

**DISPOSITION INSTRUCTIONS**

**Destroy this report when it is no longer needed.  
Do not return it to the originator.**

**DISCLAIMER**

**The findings in this report are not to be construed as an official  
Department of the Army position, unless so designated by other  
authorized documents.**

**4 May 1965**

**Report No. RR-TR-65-6**

**POLYNOMIAL GAS FLOW REGULATORS**

**by**

**T. A. Barr and R. F. Mayo**

**DA Project No. 1S222901A206**

**AMC Management Structure Code No. 5221.11.148**

**Plasma Physics Branch  
Physical Sciences Laboratory  
Directorate of Research and Development  
U. S. Army Missile Command  
Redstone Arsenal, Alabama**

## ABSTRACT

The design principles for a gas flow regulator which produces prescribed time dependent mass flow rates of gas are stated. The principles are discussed in terms of a passive system of tanks which are connected in series by sonic throttles. Each tank produces one term of a temporal polynomial. Certain considerations prevent this being made into a practical device. Alternate systems based on the same principles but using programable regulators instead of the tanks are described. One such system was built and tested. It produced a satisfactory sixth-degree polynomial substitute for a prescribed exponentially increasing gas flow rate program for a 600-kilowatt, two-arc plasma facility.

## CONTENTS

	Page
1. Introduction . . . . .	1
2. Basic Design . . . . .	1
3. Design Problems . . . . .	3
4. Design of a Practical System . . . . .	4
5. Experimental Design and Results . . . . .	5
6. Conclusions . . . . .	6

## ILLUSTRATIONS

### Figure

1	Typical Element for Generation of a Polynomial Mass Flow Rate Control System . . . . .	7
2	An Idealized Fourth-Degree Polynomial Gas Mass Flow Rate System . . . . .	7
3	(a) A Three-Stage Polynomial Gas Flow Regulator Consisting of a Constant Pressure Air Supply and Three Programable Dome Type Regulators; (b) A Polynomial Gas Flow Regulator with Programable Input Pressure System . . . . .	8
4	A Polynomial Gas Flow Regulator System with Positive and Negative Coefficients . . . . .	9
5	The Theoretical Comparison of a Desired Function to the Sixth-Degree Polynomial Substituted for It . . . . .	10
6	Graphic Representation of the Terms in Equation (3) . . . . .	11
7	(a) Typical Oscillograph Record of the Output Voltage; (b) The Log of the Output Voltage from the Pressure Transducer of the Plenum . . . . .	12

## 1. Introduction

A gas flow regulator which can be adjusted to conform to a prescribed time-dependent program is required in the development of the 8000-Kilowatt Plasma Facility at the Army Missile Command, Redstone Arsenal, Alabama. This requires an exponentially increasing gas flow rate with a maximum start-to-end flow rate ratio of 1:100 with an adjustable running time between 5 and 10 seconds. Variables such as initial gas pressure and temperature are to be initial conditions which can be changed in a more or less arbitrary manner. The regulator requires built-in adjustments which can compensate for changed inputs. The running time and the magnitudes of initial and final gas flow rates must also be adjustable to accommodate the particular flow rate program required. A system based on the mass flow limitation property of sonic orifices was designed and, in this particular case, on the polynomial approximation for an exponential. Its operation was limited to use with a two-arc, 600-kilowatt plasma facility, and as such is the prototype for the gas flow rate controller on a six-arc, 8000-kilowatt plasma facility.

## 2. Basic Design

Consider a set of tanks connected in series by sonic orifices of succeeding smaller size as in Figure 1. In each tank the discharge orifice is much smaller than the input orifice so that when sonic flow conditions are established, the mass flow rate out of a given tank is small compared to the input rate. The mass flow rate relation is:

$$\dot{m} = C A P T^{-1/2} \quad (1)$$

where  $\dot{m}$  is the mass flow rate of gas moving through an orifice of area,  $A$ , with an orifice coefficient,  $C$ . The upstream gas pressure and temperature are  $P$  and  $T$ , respectively. The mass of gas in a given tank is a function of time given by:

$$m(n) = \int_0^T [\dot{m}(n) - \dot{m}(n+1) - \dot{M}(n)] dt \approx \int_0^T \dot{m}(n) dt \quad (2)$$

where  $m$  is the mass of gas in a given tank labeled,  $n$ , and  $\dot{m}(n)$  is the flow rate of gas into, and  $\dot{m}(n+1)$  and  $\dot{M}(n)$  are flows out of the tank. By substituting Equation (1) for  $\dot{m}(n)$  in Equation (2), then

$$m(n) \approx \int_0^T C A P (n-1) [T(n-1)]^{-1/2} dt \quad (2a)$$

If the tanks are such that isothermal conditions prevail, then  $CA [T(n-1)]^{-1/2}$  may be taken to be a constant,  $G(n-1)$ . For the moment, also assume that  $P(n-1) = K(n-1)t^{n-1}$ ; that is, the pressure in the supply tank is increasing according to an integral power of time so that

$$m(n) \approx G(n-1) \cdot K(n-1) \int_0^{\tau} t^{n-1} dt \quad (2b)$$

or 
$$m(n) \approx G(n-1) K(n-1) t^n / (n-1). \quad (2c)$$

Again if isothermal conditions prevail,  $P(n)$  is proportional to  $m(n)$ , and the pressure in the  $n$ th tank is proportional to  $t^n$  provided the pressure in the  $n-1$  tank is proportional to  $t^{n-1}$ . If the zero tank is a constant pressure source such as a fixed pressure supply line, then the pressure in the first tank will be proportional to the time,  $t$ . The pressure in the second tank will be proportional to  $t^2$ , and so forth.

By tapping each of the tanks with small sonic orifices and discharging gas into a common plenum, the mass flow rate of gas into the plenum will not materially change the pressure in the tank. The sum of all the mass flow rates will be  $\Sigma \dot{M}(n)$ , and the pressure at time,  $t$ , which is proportional to the integral of this sum will be

$$P(p) = K(p) \int_0^{\tau} \Sigma \dot{M}(n) dt \quad (3)$$

where  $(p)$  refers to the plenum. (See Figures 1 and 2.)  $\dot{M}(n)$  is the mass flow rate out of the  $n$ th tank into the plenum. The rate coefficient of the discharge, of the form  $Q(n) = C(n) A [T(n)]^{-1/2}$ , for the flow from each tank to the plenum shown in Figure 2, is determined by the setting of the sonic throttle valves,  $v(n)$ . If the ideal gas law holds,  $K(p) = RT(p)/MW$ , where  $MW$  is the molecular weight of the gas being used.  $\dot{M}(n) = Q(n) K(n) t^n$  by the same reasoning used to determine  $\dot{m}(n)$ . The polynomial characteristic of the mass flow rate regulator is apparent if Equation (3) is expanded, and the value given above for  $\dot{M}(n)$  is used:

$$P(p) = K(p) \int_0^{\tau} [Q(0) K(0) + Q(1) K(1) t + Q(2) K(2) t^2, \text{ etc.}] dt \quad (4)$$

or 
$$P(p) = P(p, 0) + K(p) [Q(0) K(0) t + Q(1) K(1) t^2/2 + Q(2) K(2) t^3/3, \text{ etc.}] \quad (4a)$$

$P(p, 0)$  is the value of the pressure in the plenum at  $t = 0$ . Figure 2 shows the general plan for a polynomial gas flow regulator. The actual values of the polynomial coefficients are determined by the settings of the sonic throttles  $V(n)$  and  $v(n)$  and by the sizes of the tanks. A final sonic throttle controls the mass flow rate  $\dot{M}(T)$  from the plenum. One restriction on a system of this type limits its use to polynomials which have all positive coefficients since the gas flow from each throttle adds to the gas in the plenum.

### 3. Design Problems

A very serious limitation of another kind exists which practically precludes the use of the tank system. This is the magnitude of the initial gas flow rate and the combination of large tank sizes and high pressures which are required. The initial assumption, that the flow rate out of a given tank was to be small compared to the input simplified the analysis but makes the use of such a system impractical. An example was calculated using a fourth-degree polynomial tank system. It is assumed  $\dot{M}(T)$  is to start at 2 g/sec and rise along a fourth-degree polynomial (as an approximation to an exponential) to 4 g/sec in 2.5 seconds. The polynomial used is:

$$m(0) [1 + at + (at)^2/2 + (at)^3/6 + (at)^4/24] \approx m(0) \exp(at). \quad (5)$$

For the assumed conditions  $a = 0.272$ , and at  $t = 2.5$  second,  $at = 0.693$ . It is further assumed that 1) the mass flow rate out of any one tank through any particular orifice is 1 percent of the input mass flow rate; 2) the pressure of the system into which  $\dot{M}(T)$  is discharged is at 1 atmosphere; and 3) the sonic pressure ratio is  $> 2:1$ . Under these conditions the tank #1 must receive gas at a rate of  $2 \times 10^5$  kg/sec and be at 32 atmospheres in 2.5 seconds from start! The tank volume is calculated to be  $1.25 \times 10^4$  m<sup>3</sup>! The size of the first tank is calculated by starting with the conditions required for the fourth tank and working back to the first tank. In a second example each orifice is allowed to discharge 10 percent of the gas from any one tank. The size of tank #1 is then only 0.9 m<sup>3</sup>, but operating conditions are no longer near the ideal. Under either circumstance construction of such systems for practical use is probably not advisable. An alternate device might be one in which the polynomial tank system is used only to supply the reference pressure on a commercially available programable gas flow regulator. In this case the reduced gas flow requirements would probably permit the use of tanks of a manageable size.

#### 4. Design of a Practical System

The size problem encountered in the design of a tank polynomial may be eliminated if a programable pressure regulator is substituted for the tank. In this case a pressure-controlled regulator is substituted for each of the tanks in the previous system. This permits the use of a single relay rack of equipment to take the place of the series of large tanks. Figures 3a and 3b show the diagrams of the polynomial regulator system. This system has an error due to pressure drops through the regulators. The use of adequately sized regulators, however, reduces this error to a minimum. Figure 3a shows three of the six stages in the regulator system which has been constructed and used. Another system which does not place the total flow rate requirement on the first regulator is one in which each term of the polynomial is fed separately from the common pressure reservoir. The disadvantage of this system is the delay introduced in the opening of the higher-term regulators because of the high inlet pressure on all regulators. A third system is one in which the gas for each stage is drawn from a reservoir at a prescribed pressure for that particular stage; each source has as low a pressure as possible for proper operation thus reducing the delay time effect.

Figure 3b is a modified system which uses only one reservoir but has separate preregulation to limit the inlet pressure to each of the polynomial regulators. This is done so that the control pressures required to start the regulators to opening may be kept low. Otherwise a considerable pressure might have to be developed in the regulation chambers to start the regulator action. This would mean that each stage would be starting at a later time than its preceding adjacent stage. The preregulators may be operated to produce variable inlet pressures on each of the regulators. These variable inlet pressures may be obtained in a manner similar to the output pressures from the regulators as shown in Figure 3b. Such a system will essentially eliminate the characteristic error in the initial pressures required to start the operation of the regulators, since the head pressures on the regulators may be kept to a minimum when the regulators start to open. When the system calls for higher flow rate, the head pressure preregulators will deliver higher pressures to the regulators. The arrangement shown in Figure 3b is only one of several possible ways of achieving the desired effect.

Figure 4 shows a regulator design which may be used to generate negative coefficient terms by bleeding off gas from the plenum. The requirement in this case is that the negative coefficients cannot be generated unless the plenum pressure meets sonic throat requirements;

that is, about twice the discharge pressure. In most practical applications this limits the lowest plenum pressure to two atmospheres. Above this pressure, however, the pressure and/or mass flow rate in the plenum may make any rising and/or falling pattern describable by the particular polynomial which is constructed. The refinement shown in Figure 3b may also be included.

### 5. Experimental Design and Results

A sixth-degree polynomial system of the form shown in Figure 3a has been constructed, tested, and used in the plasma facility mentioned previously. Since the real system is not exactly isothermal and since inherent delays and pressure drops in the system prevent accurate pre-setting of the flow, regulating valves are empirically adjusted. The desired program, in this case an exponential, is approximated by a sixth-degree polynomial. The polynomial expansion of an exponential is of the form:

$$A \exp (at) = A \sum_{n=0}^{\infty} (at)^n/n! \quad (6)$$

In many cases such as the one cited here, an approximation to the exponential using a limited number of terms is sufficient. Here, the exponential is approximated by:

$$A \exp (at) \approx A [1 + (at) + (at)^2/2 + (at)^3/6 + (at)^4/24 + (at)^5/120 + (at)^6/720]. \quad (7)$$

This approximation is used in the design of the flow rate control equipment. The polynomial terms are tabulated as functions of time, and the value of the polynomial as a function of time is determined. The individual gas pressures are measured at the gages, G, of Figure 3a, and the total mass flow into the plasma facility test section is calculated from the pressure and the known size of the throat in the plasma facility.

Trial values for valve settings are determined by observing the time required for a given gage to indicate a prescribed pressure. The desired pressure is calculated from the tabulated values of the polynomial components. The valves, v, are set to a first approximation (all valves are vernier needle valves). The program is then run for varying lengths of time to determine the actual mass flow rate to the system. The actual mass flow is then compared to the desired flow rate and valves, v, are readjusted. If the pressures on the gages, G, are low, as they may well be due to line loss, the valves, V, are readjusted also. Two or three complete readjustment cycles generally will put the actual mass flow rate equal to the required program (within the operating errors of the system).

Figure 5 shows a typical gas flow rate program for the plasma facility. The curve for the theoretical sixth-degree polynomial and the desired exponential are so close for the time interval that their separation on the graph is not practical. Their differences are plotted as a dashed line on the same graph. Figure 6 shows the separate terms of the sixth-degree polynomial of Equation (7). It is from these terms that the expected values of pressures on gages, G, are calculated. The best fit of the polynomial to the exponential would be obtained by the method of least squares. In this case the two curves to be matched, exponential and polynomial, are expressed analytically, and the least squares fit is obtainable by a purely analytical technique in which the values of the polynomial coefficients are calculated in terms of integrals containing Legendre polynomials. The high accuracy of this procedure is not required for the application cited here, and the calculated values for the polynomial coefficients obtained from Equation (7) are used here.

By comparing a logarithmically compressed signal to the desired program at specified times for any particular number of terms, the valve settings were adjusted (as described previously) to give the correct slope and magnitude to the plenum pressure curve. When all terms were added, the logarithmically compressed transducer voltage produced a straight line with the appropriate slope and magnitude indicating that the gas flow rate into the plenum was rising along the prescribed exponential. Figure 7a shows a typical oscillographic record of the output voltage from the pressure transducer on the plasma facility plenum. This record was made without the electric arcs' being operated in order to show the mass flow rate effect only. Figure 7a is the same signal after it has been logarithmically compressed. Some deviation from the exponential is easily shown by laying a straight edge along logarithmically compressed signal line. Improvements can be made readily even in this case but were not required for tests in which this flow rate program was used.

## 6. Conclusions

The polynomial gas flow rate controller (Figure 3a) has been constructed and tested. It has been used to control the flow of air in a 600-kilowatt, two-arc plasma facility. The prescribed program in this case was an exponential which increased the mass flow rate by 2:1 over 2.5 seconds (Figure 7a). The same controller has been tested over 5:1 flow rate range and over 1 to 10 seconds of operating time. It has performed satisfactorily in all cases, and should do as well over more extended ranges of operation. This device made from relatively inexpensive commercially available components has proved to be a reasonable substitute for more elaborate variable nozzle flow rate controllers.

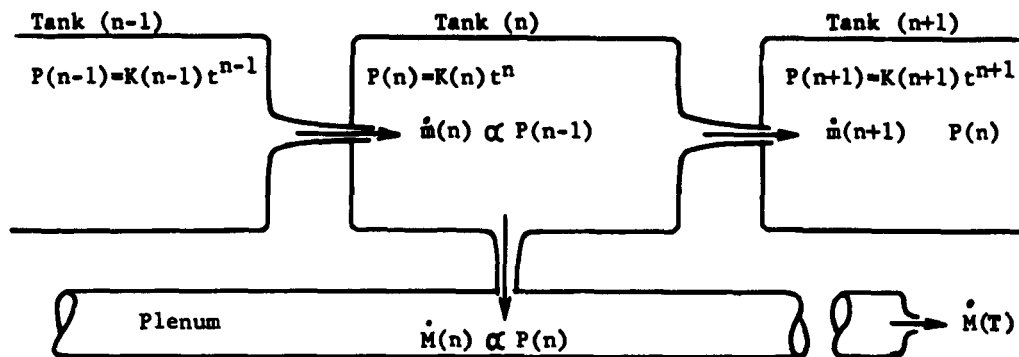

Figure 1. A typical element (tank) for generation of a polynomial mass flow rate control system. Conditions for proper operation require that  $\dot{m}(n+1) + \dot{M}(n) \ll \dot{m}(n)$ . The gas enters the tank from the preceding tank on the left and is discharged to the succeeding tank on the right and also to the plenum shown below the tanks. It is the total mass flow rate of gas into the plenum from all tanks which is proportional to the sum of the time dependent pressures in the tanks. To produce an accurate mass flow rate from the plenum,  $\dot{M}(T)$  must be much less than the least  $\dot{M}(n)$ .

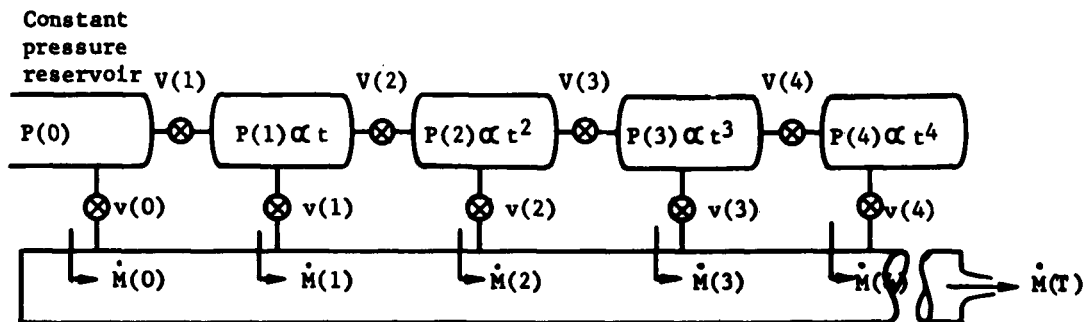

Figure 2. An idealized fourth-degree polynomial gas mass flow rate system. The areas labeled with  $P(n)$  are the tanks which receive gas through valves,  $V(n)$ , on the left and discharge gas to the succeeding tank through valves,  $V(n+1)$ , on the right and to the plenum below through valves,  $v(n)$ . All valves are vernier controlled sonic throttles. The system is assumed to be isothermal although a real system built on this principle may not be isothermal and will require compensating adjustments of the valves.

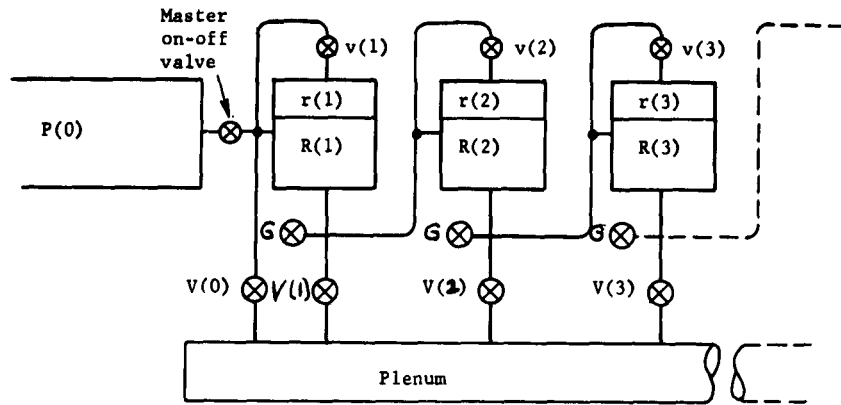

Figure 3a. A three-stage polynomial gas flow regulator consisting of a constant pressure air supply and three programmable dome type regulators. Regulators are shown with pressure control domes,  $r$ , and regulator valve sections,  $R$ . Valves,  $V$ , are sonic throttles which regulate the rate of gas discharge from each regulator into the receiver (plenum). Valves,  $v$ , are sonic throttles used to control the rate of gas flow (and thereby the pressure) to the pressure control domes.

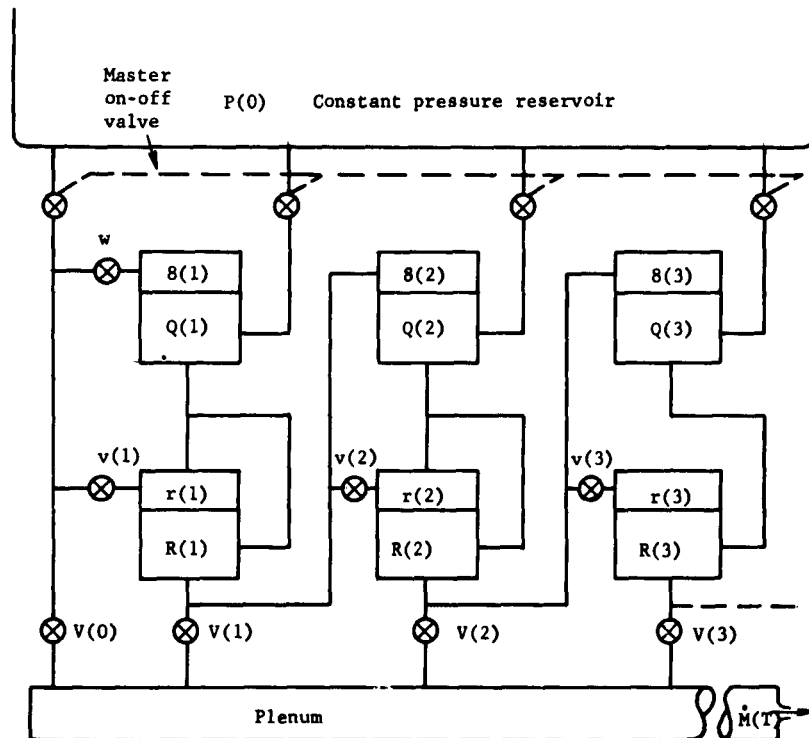

Figure 3b. A polynomial gas flow regulator with programmable input pressure system to reduce starting time delays. The regulators ( $Q$ ,  $q$ ) are used to control the head pressure on the main control regulators ( $R$ ,  $r$ ).

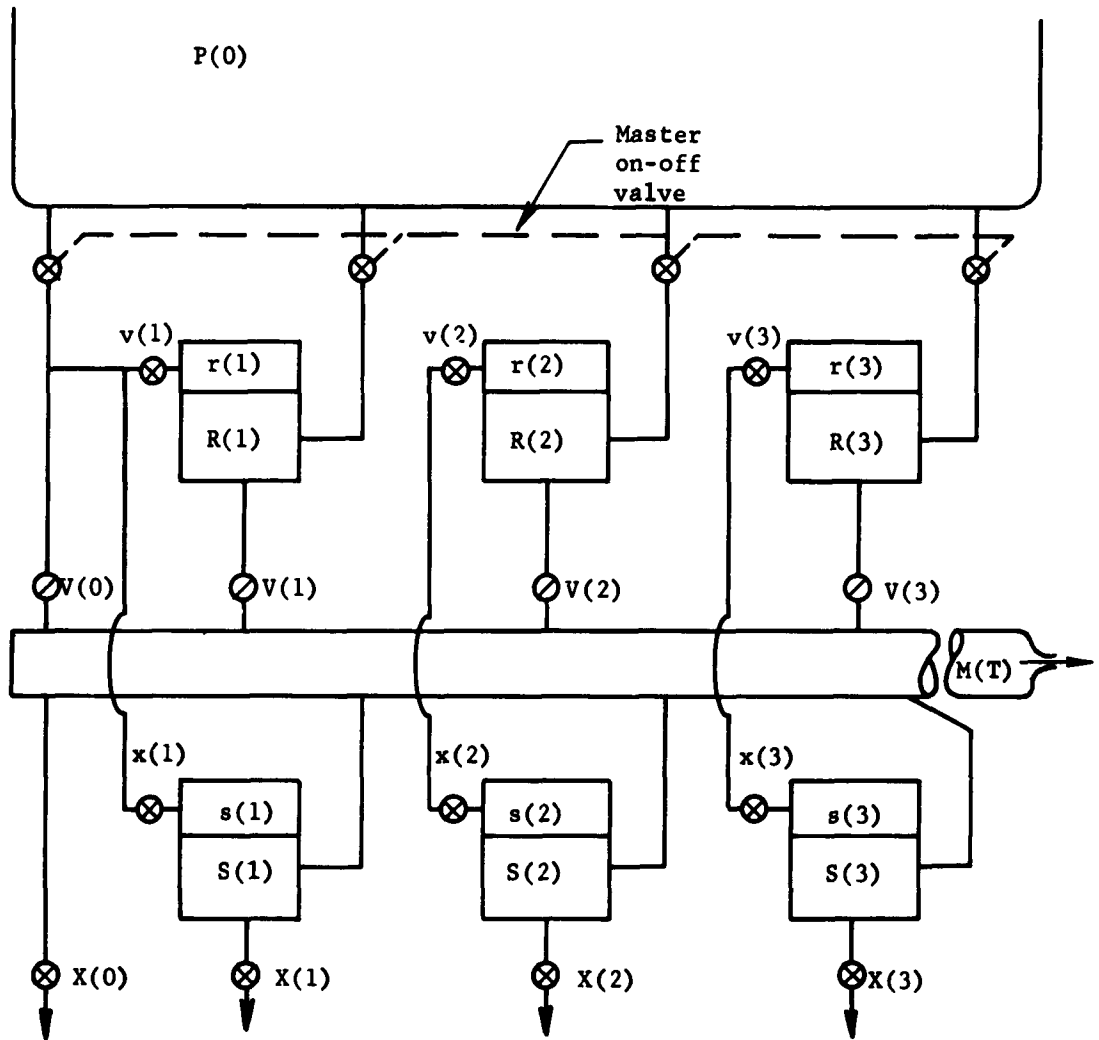

Figure 4. A polynomial gas flow regulator system with positive and negative coefficients. This system will produce a controlled rising and falling gas flow rate within the limitation that pressure ratios across any of the valves remain high enough to maintain sonic throat conditions. This in general means that the lowest pressure in the plenum must be greater than about two atmospheres if the bleed-off regulators ( $S, s$ ) are discharging gas to the atmosphere through the sonic throttles,  $X$ . The valves,  $x$ , perform the same function on the ( $S, s$ ) regulators that the valves,  $v$ , perform on the regulators ( $R, r$ ).

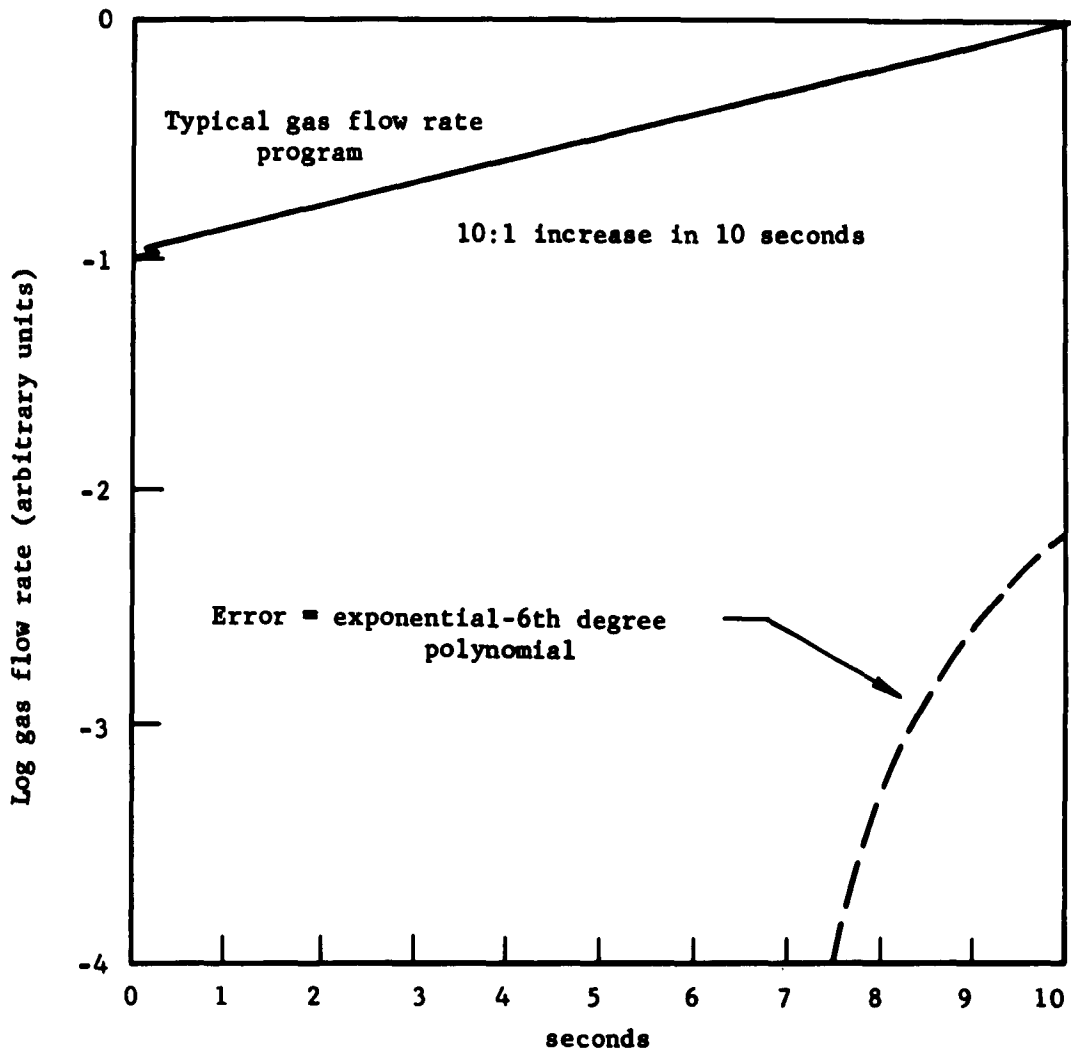

Figure 5. The theoretical comparison of a desired function to the sixth-degree polynomial substituted for it. In this case the desired function is an increasing exponential. The error curve (dashed line) is the difference between the exponential and the sixth-degree polynomial obtained by using the first seven terms in the series expansion for the exponential (Equation 2). This polynomial is not the one which is the best fit in the sense of a least squares fit.

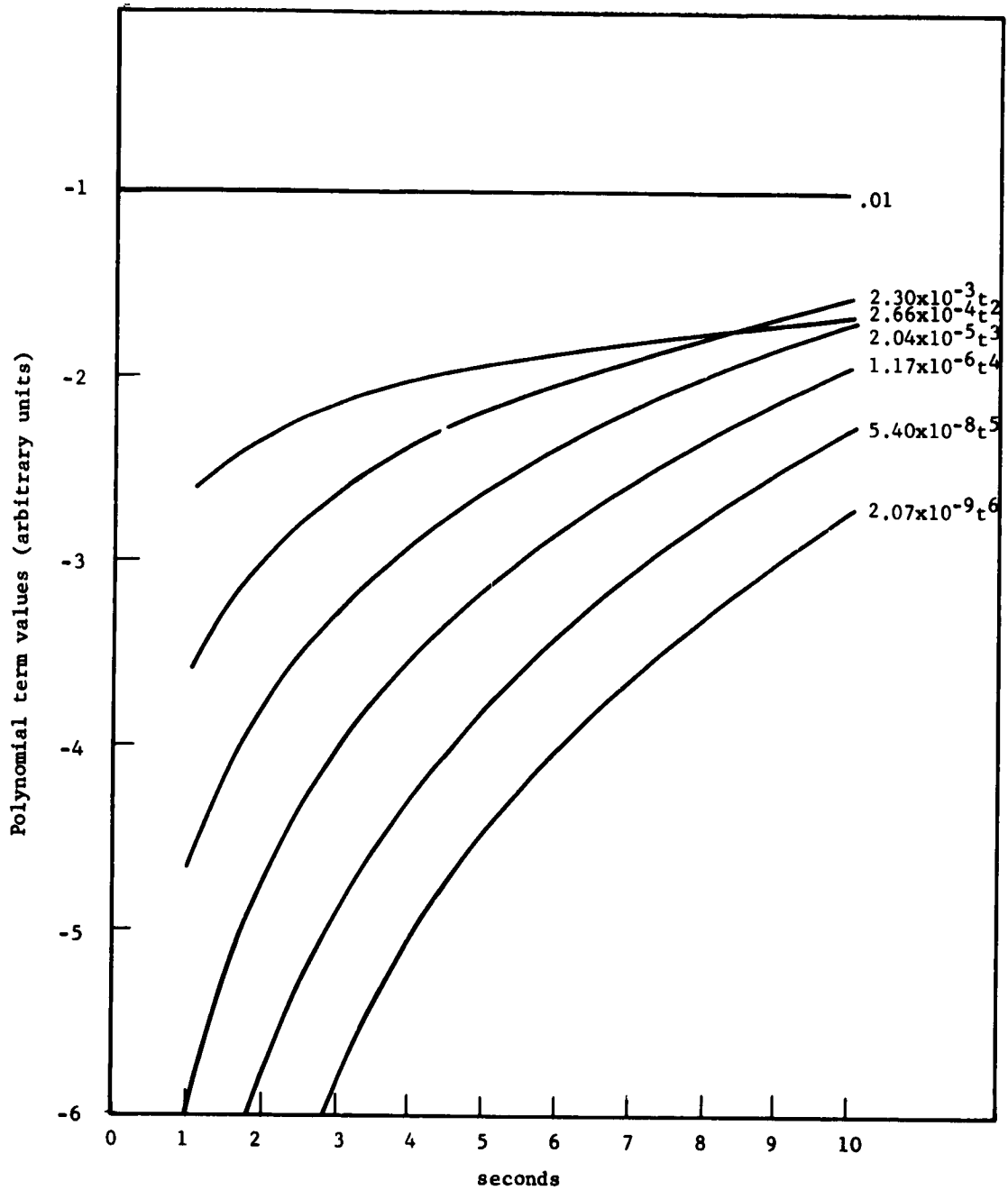

Figure 6. The graphic representation of the terms in Equation (3), the sixth-degree polynomial approximation to the desired exponential. This graph may be compared to the recorded pressures from each stage of the polynomial flow rate control system to determine if valves,  $v$ , have been set correctly. This set of curves is for a 10:1 increase over 10 seconds. Typical starting  $\dot{M}(T)$  is .01 kg/sec.

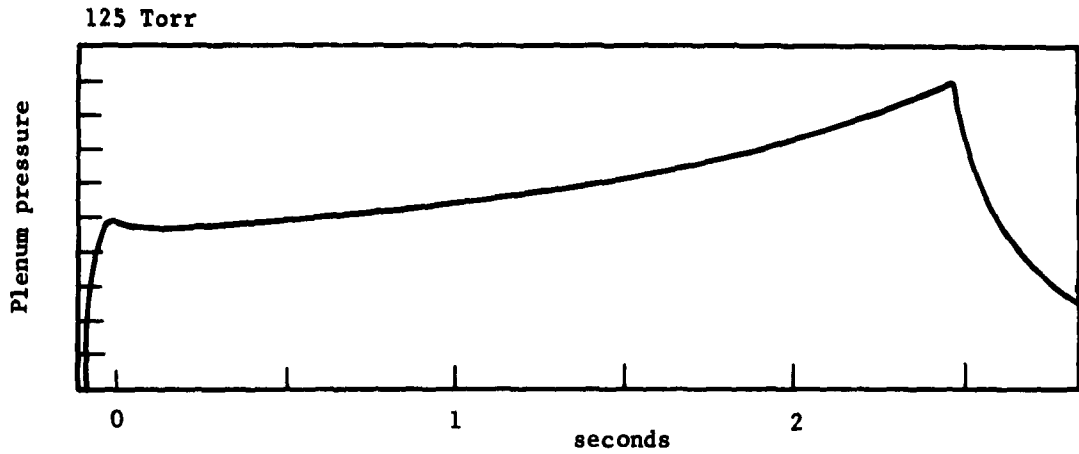

Figure 7a. A typical oscillograph record of the output voltage from the pressure transducer on the plenum of the plasma facility. This record was made without the electric arcs' being operated in order to show the mass flow rate effect only.

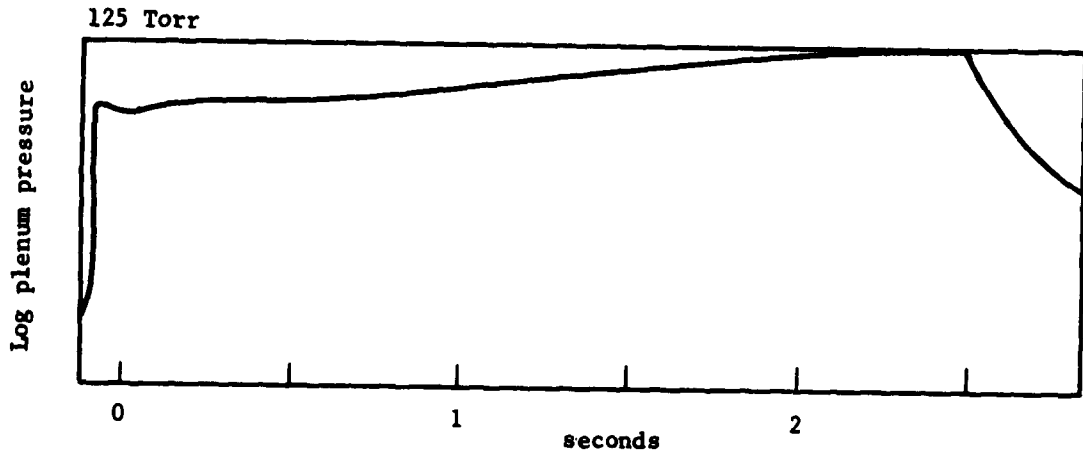

Figure 7b. The same signal as 7a after it has been logarithmically compressed.

## DISTRIBUTION

	No. of copies
Defense Documentation Center Cameron Station Alexandria, Virginia 22314	20
U. S. Army Missile Command Distribution List A	84
AMSMI-XS, Dr. Carter	1
AMSMI-R, Mr. McDaniel	1
-RR, Dr. Hallowes	1
Mr. Shapiro	1
Mrs. Wheeler	1
-RRP, Dr. Barr	25
-RK	1
-RE	1
-RG	1
-RL	1
-RFE, Mr. Garner	6
-RS	1
-RT	1
-RBL	5
-RAP	1

**UNCLASSIFIED**  
Security Classification

DOCUMENT CONTROL DATA - R&D		
<i>(Security classification of title, body of abstract and indexing annotation must be entered when the overall report is classified)</i>		
1. ORIGINATING ACTIVITY (Corporate author) <b>Physical Sciences Laboratory, Dir of R&amp;D U. S. Army Missile Command Redstone Arsenal, Alabama</b>		2a. REPORT SECURITY CLASSIFICATION <b>UNCLASSIFIED</b>
		2b. GROUP <b>N/A</b>
3. REPORT TITLE <b>POLYNOMIAL GAS FLOW REGULATORS</b>		
4. DESCRIPTIVE NOTES (Type of report and inclusive dates)		
5. AUTHOR(S) (Last name, first name, initial) <b>Barr, T. A. and Mayo, R. F.</b>		
6. REPORT DATE <b>4 May 1965</b>	7a. TOTAL NO. OF PAGES <b>13</b>	7b. NO. OF REFS <b>0</b>
8a. CONTRACT OR GRANT NO.  A. PROJECT NO. (DA) <b>1S222901A206</b>  c. AMC Management Structure Code No. <b>5221.11.148</b> d.	9a. ORIGINATOR'S REPORT NUMBER(S) <b>RR-TR-65-6</b>	
		9b. OTHER REPORT NO(S) (Any other numbers that may be assigned this report) <b>AD _____</b>
10. AVAILABILITY/LIMITATION NOTICES <b>Qualified requesters may obtain copies of this report from DDC.</b>		
11. SUPPLEMENTARY NOTES	12. SPONSORING MILITARY ACTIVITY <b>Same as Item 1.</b>	
13. ABSTRACT <p>The design principles for a gas flow regulator which produces prescribed time dependent mass flow rates of gas are stated. The principles are discussed in terms of a passive system of tanks which are connected in series by sonic throttles. Each tank produces one term of a temporal polynomial. Certain considerations prevent this being made into a practical device. Alternate systems based on the same principles but using programable regulators instead of the tanks are described. One such system was built and tested. It produced a satisfactory sixth-degree polynomial substitute for a prescribed exponentially increasing gas flow rate program for a 600-kilowatt, two-arc plasma facility.</p>		

DD FORM 1473  
1 JAN 64

**UNCLASSIFIED**  
Security Classification

14. KEY WORDS	LINK A		LINK B		LINK C	
	ROLE	WT	ROLE	WT	ROLE	WT
plasma facility gas flow regulator plenum sonic throttles polynomial tank system exponential approximation flow rate controllers						
<b>INSTRUCTIONS</b>						
<p><b>1. ORIGINATING ACTIVITY:</b> Enter the name and address of the contractor, subcontractor, grantee, Department of Defense activity or other organization (<i>corporate author</i>) issuing the report.</p> <p><b>2a. REPORT SECURITY CLASSIFICATION:</b> Enter the overall security classification of the report. Indicate whether "Restricted Data" is included. Marking is to be in accordance with appropriate security regulations.</p> <p><b>2b. GROUP:</b> Automatic downgrading is specified in DoD Directive 5200.10 and Armed Forces Industrial Manual. Enter the group number. Also, when applicable, show that optional markings have been used for Group 3 and Group 4 as authorized.</p> <p><b>3. REPORT TITLE:</b> Enter the complete report title in all capital letters. Titles in all cases should be unclassified. If a meaningful title cannot be selected without classification, show title classification in all capitals in parenthesis immediately following the title.</p> <p><b>4. DESCRIPTIVE NOTES:</b> If appropriate, enter the type of report, e.g., interim, progress, summary, annual, or final. Give the inclusive dates when a specific reporting period is covered.</p> <p><b>5. AUTHOR(S):</b> Enter the name(s) of author(s) as shown on or in the report. Enter last name, first name, middle initial. If military, show rank and branch of service. The name of the principal author is an absolute minimum requirement.</p> <p><b>6. REPORT DATE:</b> Enter the date of the report as day, month, year, or month, year. If more than one date appears on the report, use date of publication.</p> <p><b>7a. TOTAL NUMBER OF PAGES:</b> The total page count should follow normal pagination procedures, i.e., enter the number of pages containing information.</p> <p><b>7b. NUMBER OF REFERENCES:</b> Enter the total number of references cited in the report.</p> <p><b>8a. CONTRACT OR GRANT NUMBER:</b> If appropriate, enter the applicable number of the contract or grant under which the report was written.</p> <p><b>8b, 8c, &amp; 8d. PROJECT NUMBER:</b> Enter the appropriate military department identification, such as project number, subproject number, system numbers, task number, etc.</p> <p><b>9a. ORIGINATOR'S REPORT NUMBER(S):</b> Enter the official report number by which the document will be identified and controlled by the originating activity. This number must be unique to this report.</p> <p><b>9b. OTHER REPORT NUMBER(S):</b> If the report has been assigned any other report numbers (<i>either by the originator or by the sponsor</i>), also enter this number(s).</p>	<p><b>10. AVAILABILITY/LIMITATION NOTICES:</b> Enter any limitations on further dissemination of the report, other than those imposed by security classification, using standard statements such as:</p> <p>(1) "Qualified requesters may obtain copies of this report from DDC."</p> <p>(2) "Foreign announcement and dissemination of this report by DDC is not authorized."</p> <p>(3) "U. S. Government agencies may obtain copies of this report directly from DDC. Other qualified DDC users shall request through _____."</p> <p>(4) "U. S. military agencies may obtain copies of this report directly from DDC. Other qualified users shall request through _____."</p> <p>(5) "All distribution of this report is controlled. Qualified DDC users shall request through _____."</p> <p>If the report has been furnished to the Office of Technical Services, Department of Commerce, for sale to the public, indicate this fact and enter the price, if known.</p> <p><b>11. SUPPLEMENTARY NOTES:</b> Use for additional explanatory notes.</p> <p><b>12. SPONSORING MILITARY ACTIVITY:</b> Enter the name of the departmental project office or laboratory sponsoring (<i>paying for</i>) the research and development. Include address.</p> <p><b>13. ABSTRACT:</b> Enter an abstract giving a brief and factual summary of the document indicative of the report, even though it may also appear elsewhere in the body of the technical report. If additional space is required, a continuation sheet shall be attached.</p> <p>It is highly desirable that the abstract of classified reports be unclassified. Each paragraph of the abstract shall end with an indication of the military security classification of the information in the paragraph, represented as (TS), (S), (C), or (U).</p> <p>There is no limitation on the length of the abstract. However, the suggested length is from 150 to 225 words.</p> <p><b>14. KEY WORDS:</b> Key words are technically meaningful terms or short phrases that characterize a report and may be used as index entries for cataloging the report. Key words must be selected so that no security classification is required. Identifiers, such as equipment model designation, trade name, military project code name, geographic location, may be used as key words but will be followed by an indication of technical context. The assignment of links, rules, and weights is optional.</p>					