

UNCLASSIFIED

AD 4 6 4 4 8 6

DEFENSE DOCUMENTATION CENTER

FOR

SCIENTIFIC AND TECHNICAL INFORMATION

CAMERON STATION ALEXANDRIA, VIRGINIA



UNCLASSIFIED

NOTICE: When government or other drawings, specifications or other data are used for any purpose other than in connection with a definitely related government procurement operation, the U. S. Government thereby incurs no responsibility, nor any obligation whatsoever; and the fact that the Government may have formulated, furnished, or in any way supplied the said drawings, specifications, or other data is not to be regarded by implication or otherwise as in any manner licensing the holder or any other person or corporation, or conveying any rights or permission to manufacture, use or sell any patented invention that may in any way be related thereto.

CATALOGED BY: DDC  
464486

FABRICATION OF GLASS MASKS, AND  
THEIR APPLICATION TO THIN-FILM CIRCUIT DEPOSITION

TECHNICAL DOCUMENTARY REPORT NO. ESD-TDR-64-634

MAY 1965

P. Everett

R. Roderick

Prepared for

DIRECTORATE OF COMPUTERS  
ELECTRONIC SYSTEMS DIVISION  
AIR FORCE SYSTEMS COMMAND  
UNITED STATES AIR FORCE

L. G. Hanscom Field, Bedford, Massachusetts

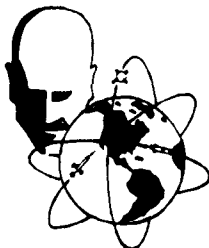

Project 508

Prepared by

THE MITRE CORPORATION  
Bedford, Massachusetts  
Contract AF19(628)-2390

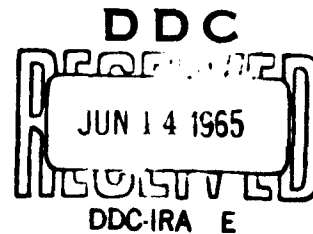

ESD-TDR-64-634

W-06760

FABRICATION OF GLASS MASKS, AND  
THEIR APPLICATION TO THIN-FILM CIRCUIT DEPOSITION

TECHNICAL DOCUMENTARY REPORT NO. ESD-TDR-64-634

MAY 1965

P. Everett

R. Roderick

Prepared for

DIRECTORATE OF COMPUTERS

ELECTRONIC SYSTEMS DIVISION

AIR FORCE SYSTEMS COMMAND

UNITED STATES AIR FORCE

L. G. Hanscom Field, Bedford, Massachusetts

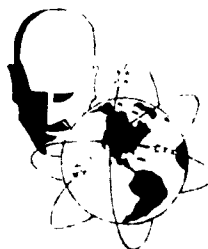

Project 508

Prepared by

THE MITRE CORPORATION

Bedford, Massachusetts

Contract AF19(628)-2390

## ABSTRACT

This report describes a process which has been developed for the etching of glass masks. A discussion of the requirements for these masks in thin-film circuit deposition precedes a detailed description of the process.

Six masks were produced by the process, and measurements were made to determine the tolerances obtained.

## REVIEW AND APPROVAL

This technical documentary report has been reviewed and is approved.

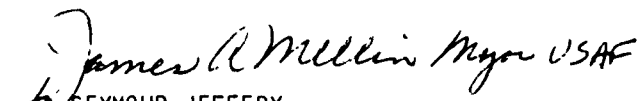
  
for SEYMOUR JEFFERY  
Major, USAF  
Chief, Computer Division  
Directorate of Computers

## TABLE OF CONTENTS

	<u>Page</u>
LIST OF ILLUSTRATIONS	vi
Section I - INTRODUCTION	1
RESISTANCE MONITORING METHODS	1
Previous Work	1
Direct Monitoring	2
Section II - PROCESS	8
MATERIALS	8
EQUIPMENT	8
ARTWORK AND PHOTOGRAPHY	8
ETCHING	8
Stage 1 - Back Etch	9
Stage 2 - Aperture Etch	10
Section III - PROBLEM AREAS IN THE PROCESS	12
POOR ADHESION OF KMER TO GLASS	12
DEPENDENCE OF ETCHING RATE ON ETCHED AREAS	13
DIFFICULTY IN DETERMINING COMPLETION OF ETCHING	13
Section IV - MEASUREMENTS ON SIX MASKS	14
Section V - CONCLUSIONS	19
REFERENCES	20

## LIST OF ILLUSTRATIONS

<u>Fig. No.</u>		<u>Page</u>
1	Monitor Substrate	2
2	Monitor Substrate in Holder	2
3	Conductor Pattern on Circuit Substrate for Two Resistors in Series	3
4	Mask for Two Resistors in Series with Monitoring Contacts	3
5	Evaporation Assembly with Proposed Monitoring Method	5
6	Circuit Diagram of Resistor Terminating Network	6
7	Substrate Details	7
8	Completed Mask	7
9	Photographic Mask Negative	9
10	Glass with Tape on Both Sides	10
11	Measurement Details	17

## SECTION I

### INTRODUCTION

The work described in this report was performed as part of a program to improve methods for making thin-film microcircuits. It represents our efforts to develop a method of directly monitoring the resistances of resistors as they are being deposited in a circuit.

### RESISTANCE MONITORING METHODS

#### Previous Work

In previous work, the resistances have been monitored by the measurement of a resistor on a separate substrate which is deposited simultaneously.<sup>[1]</sup> This method is illustrated in Figs. 1 and 2. The monitor substrate is a piece of glass 1/2-inch square. One surface of the substrate has two stripes of gold separated by a 1/4-inch gap, as shown in Fig. 1. The monitor substrate is placed in a special holder with electrical contacts to press against the gold areas of the monitor, as shown in Fig. 2. The holder has an opening in the bottom so that when the holder is placed in an evaporant stream, deposition will take place on the exposed glass, bridging between the gold areas. The resistance between the electrical contacts can be monitored.

When a resistor deposition is carried out for a thin-film circuit, the special holder is loaded with a monitor substrate as described above, and placed alongside the circuit deposition holder. The resistor material is deposited until the monitor indicates that a film with the desired surface resistivity has been deposited. This method of monitoring has led to a poor yield for close tolerance resistors, as the relationship between the monitor

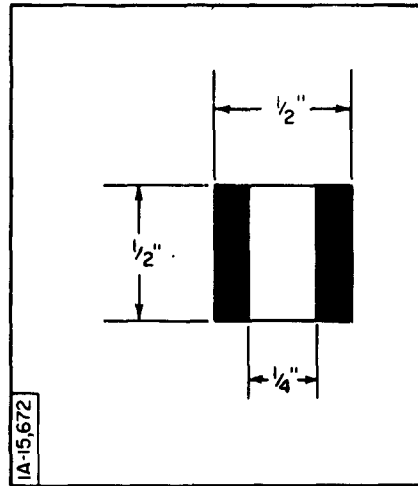

Fig. 1 Monitor Substrate

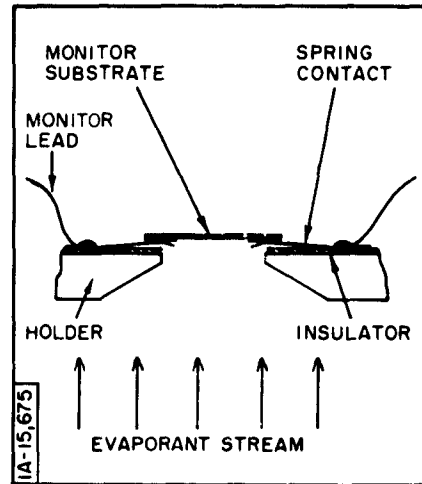

Fig. 2 Monitor Substrate in Holder

resistor and the circuit resistors appears to vary. Factors which may contribute to this variation include the following:

- (1) lack of precise definition of the monitor resistor size
- (2) difficulty of accurately measuring low resistance, and
- (3) the distance between the monitor and the circuit.

### Direct Monitoring

In the direct monitoring method proposed, one or more of the resistors in the actual circuit being deposited will be utilized for monitoring the deposition. In general, the resistor with the highest desired accuracy will be chosen.

### Mask Description

The masks, or their surfaces, will be made of an insulating material. A conducting pattern will be deposited on the substrate side of the mask to contact the conductor terminations of the resistor or resistors selected. The conducting

pattern on the mask will extend to the edges of the mask so that connections can be made to an external measuring system. The proposed method is illustrated in Figs. 3, 4, and 5 for a simple case where it is required to monitor two resistors in series in the circuit.

Figure 3 shows a circuit substrate with the three sections of circuit conductor associated with the monitoring. There would be many more conductors in a typical circuit, but for simplicity they will not be included in the illustrations.

Figure 4 shows the mask, with the apertures for the two resistors to be monitored. Once again, a circuit would generally have many more resistors; hence, the mask would have many more apertures. However, for simplicity, only the apertures for the monitored resistors are shown. Figure 4 also shows the two conducting areas on the mask, which will make contact to conductors A and B on the circuit substrates.

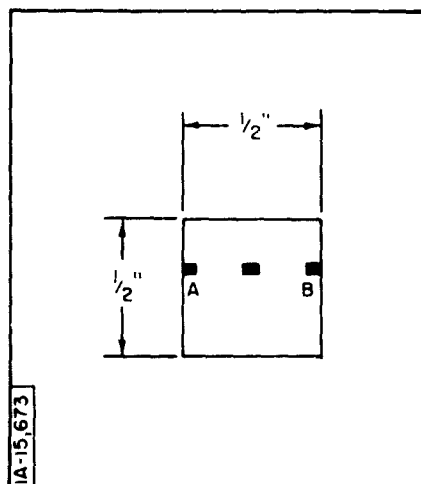

Fig. 3 Conductor Pattern on Circuit Substrate for Two Resistors in Series

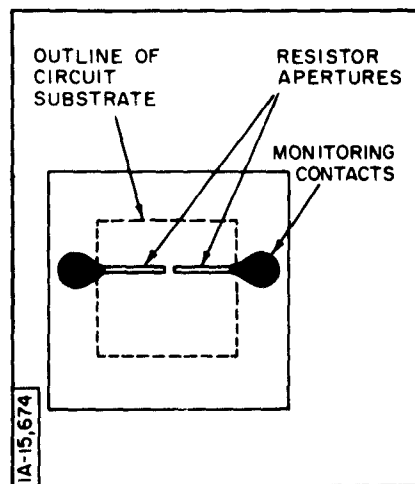

Fig. 4 Mask for Two Resistors in Series with Monitoring Contacts

Figure 5 shows the assembly for evaporation. It can be seen that when resistor deposition commences, the resistance between the monitor leads will be equal to the sum of the two resistors. To ensure good electrical contact, pressure will be applied to the substrate over the contact areas as indicated in Figure 5.

The reasons for the choice of glass for making insulating masks were as follows:

- (1) it is electrically insulating;
- (2) it will withstand 250°C (the deposition temperature used);
- (3) it is rigid;
- (4) it can be cleaned easily; and
- (5) some information is available on the etching of glass.

#### Insulating Mask Fabrication

The major difficulty in the application of the proposed monitoring method lies in the fabrication of insulating masks. Initially, some very crude masks were made by sandblasting apertures in glass microsheet. Experiments with these masks indicated the feasibility of this method of monitoring, if some more suitable masks could be obtained. This led to the development of the process described for chemical etching of glass masks.

The reasons for choosing Corning #0211 microsheet glass were:

- (1) it can be obtained in thin sheets (less than 0.003-inch thick), and
- (2) it etches cleanly in hydrofluoric acid. (Some glasses go spongy.)

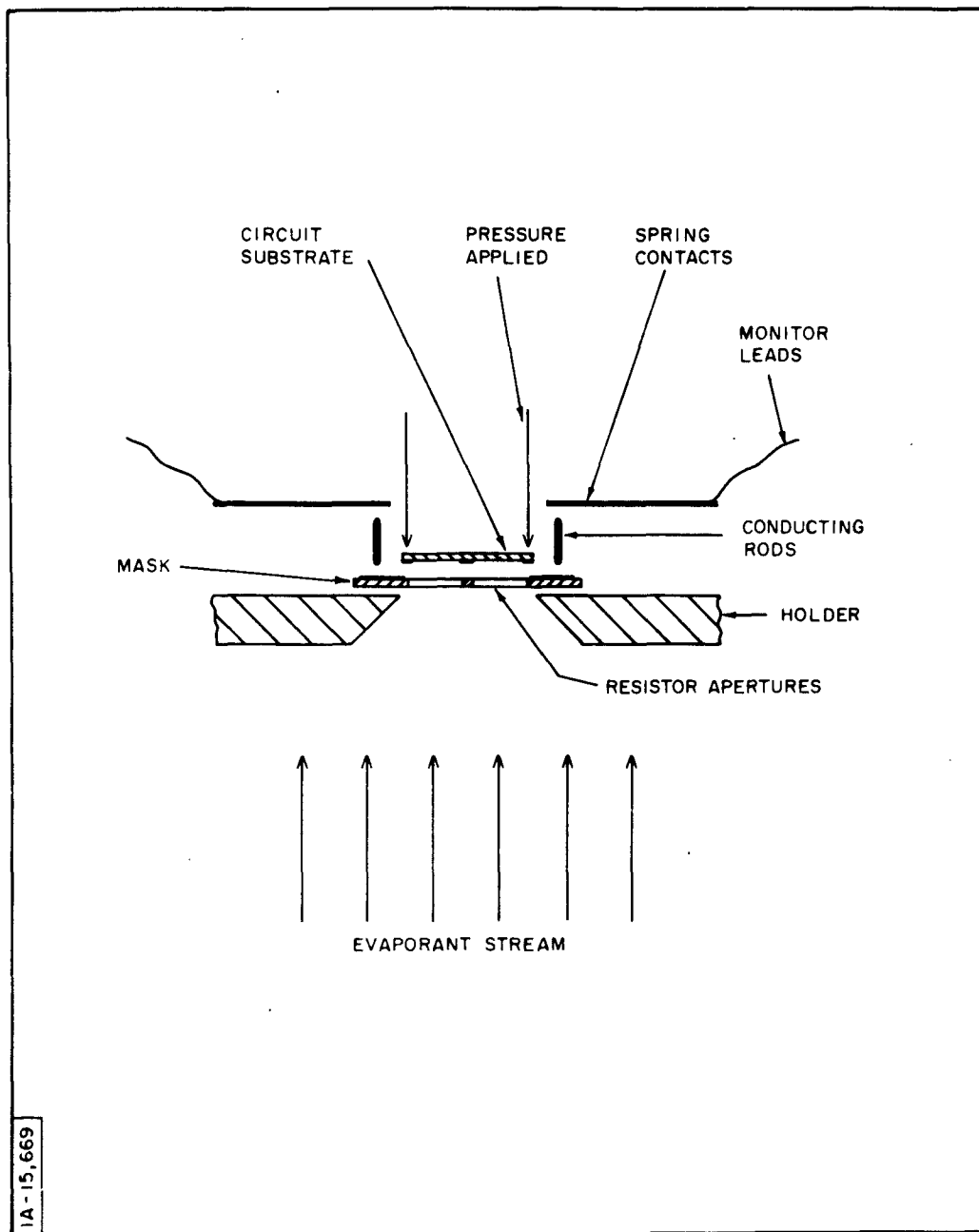

1A-15,669

Fig. 5 Evaporation Assembly with Proposed Monitoring Method

Disadvantages in the use of glass include:

- (1) photo-resists adhere poorly to glass, and
- (2) thin glass is fragile.

It was decided to overlook these disadvantages because of the lack of other suitable insulating materials.

Glass 0.010-inch thick was chosen as being the thinnest that could be handled successfully. However, this is rather thick for accurate etching of masks, so it was etched to approximately 0.005-inch thick in the region of the mask apertures as a first stage in the process.

In view of its simplicity, a resistor terminating network, with ten identical resistors was chosen for the experimental glass masks. The circuit is shown in Fig. 6, with the substrate details shown in Fig. 7. Figure 8 is a photograph of a completed, glass resistor mask.

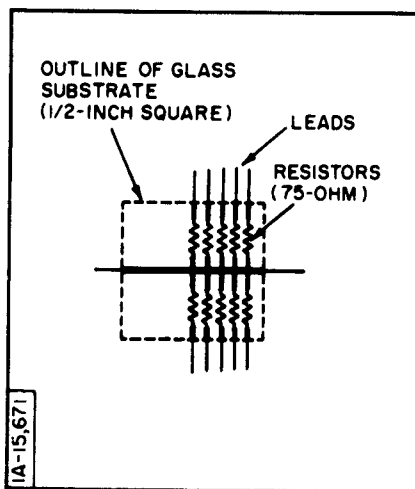
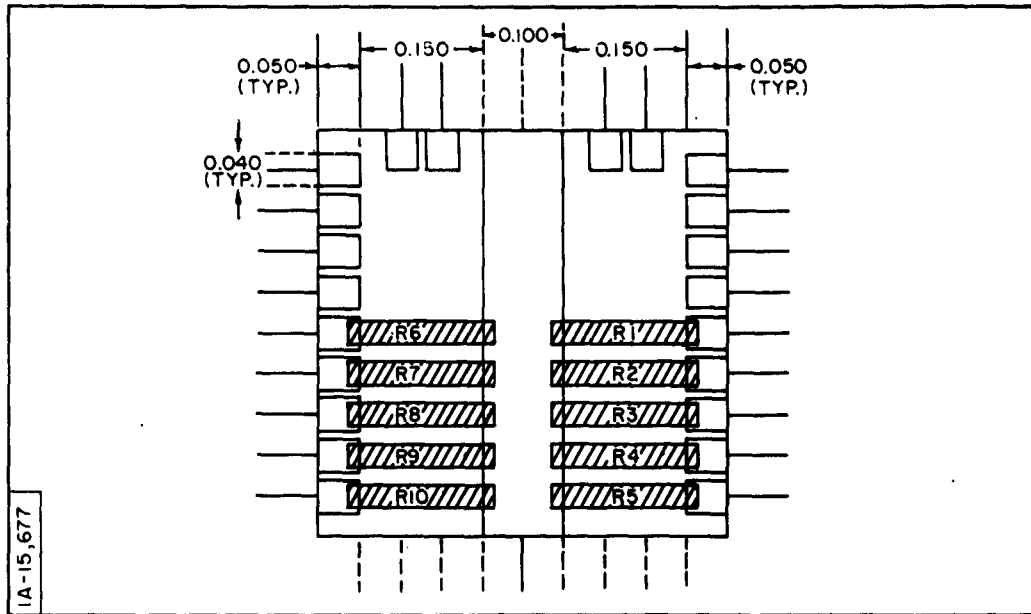

Fig. 6 Diagram of Circuit Resistor Terminating Network



IA-15,677

Fig. 7 Substrate Details

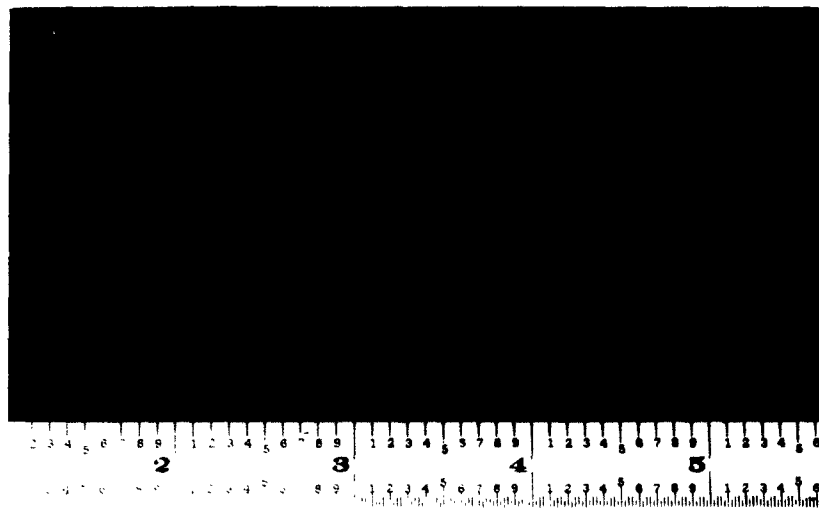

Fig. 8 Completed Mask

## SECTION II

### PROCESS

#### MATERIALS

The materials used in the process are enumerated below

- (1) Corning Glass Microsheet #0211, nominally 0.010-inch thick in rectangles ground to 0.75 inch x 2.50 inch;
- (2) acid-resistant, pressure-sensitive tape, Scotch Brand 3VEA S7334;
- (3) solution of Apiezon black wax in trichloroethylene (concentration not critical);
- (4) common organic solvents;
- (5) chromic acid cleaner (99 grams  $K_2Cr_2O_7$ ; 1500 cc  $H_2SO_4$  concentrated; 150 cc distilled  $H_2O$ );
- (6) hydrofluoric acid, 47%;
- (7) Kodak Metal Etch Resist (KMER); and
- (8) SK-4 KMER stripper.

#### EQUIPMENT

Standard, metal mask-making equipment was used. [2]

#### ARTWORK AND PHOTOGRAPHY

Conventional techniques were used [2] to prepare a photographic negative of the required masks. The negative is shown in Fig. 9.

#### ETCHING

There are two stages in the etching: back etch and aperture etch. In the first stage, one side of the glass is etched in the region of the apertures to reduce the thickness to approximately 0.005 inch. In the second stage, the apertures are etched from both sides.

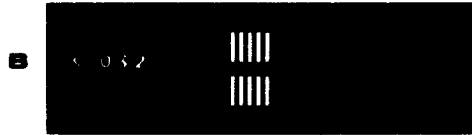

Fig. 9 Photographic Mask Negative

#### Stage 1 - Back Etch

The steps involved in the back-etch stage are described below.

- (1) The thickness of the glass is measured with a micrometer to determine what thickness of glass must be removed to leave 0.005 inch.
- (2) The glass is cleaned in chromic acid cleaner at 45<sup>o</sup> C for 3 minutes, followed by a 1-minute rinse in distilled water.
- (3) The glass is dried first with lens paper and forced hot air, and then in an oven at 80<sup>o</sup> C for 15 minutes.
- (4) A 1/2-inch square piece of the pressure sensitive tape is applied to one side of the glass to cover the area to be etched.
- (5) A 3/4-inch square piece of the tape is applied to the other side of the glass, symmetrically with the 1/2-inch square of tape. A sketch of the glass at this stage is shown in Fig. 10.
- (6) Both sides and the edges of the glass are coated with the black wax solution, care being taken to overlap the squares of tape. The wax is then oven-dried for 15 minutes at 80<sup>o</sup>C.
- (7) The 1/2-inch square of tape is removed, and the exposed glass cleaned with isopropyl alcohol to remove the sticky film left by the tape.
- (8) The thickness of the glass, plus the remaining layer of tape, is measured and recorded.

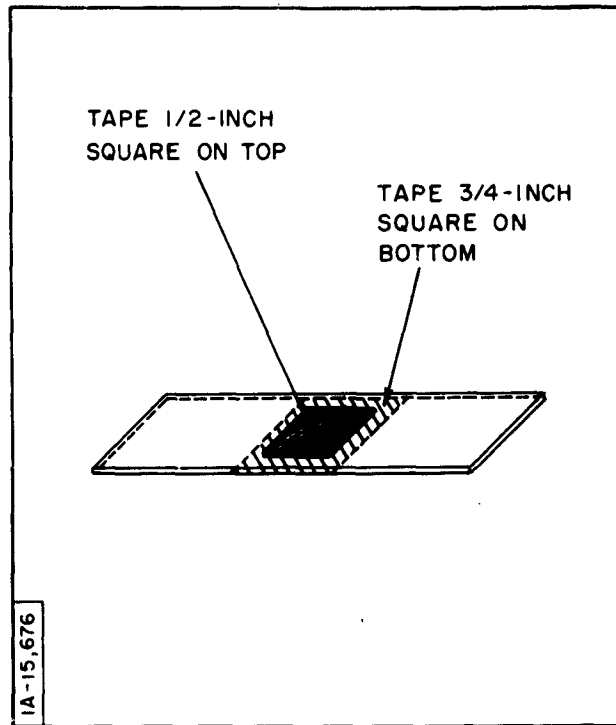

Fig. 10 Glass with Tape on Both Sides

- (9) The glass is immersed in hydrofluoric acid. It is repeatedly etched for 1 minute, removed and rinsed with distilled water, and the measurement of step (8) repeated. This procedure is continued until the measurement indicates that the right amount of material has been removed.
- (10) The black wax and tape are removed with trichlorethylene. The glass is rinsed in alcohol, distilled water, and then dried.

#### Stage 2 - Aperture Etch

The steps involved in the aperture-etch stage are listed below.

- (1) The glass is cleaned and dried as in steps (2) and (3) of stage 1.

- (2) A 4:1 solution of KMER and KMER thinner is applied to one side of the glass using a hypodermic syringe with a filter attached. The glass is then spun at 4000 rpm for 3 seconds. This operation is repeated to coat the other side.
- (3) The coated glass is placed in a light-proof container, and baked for 2 hours at 80°C in an air-circulating oven. This is followed by a vacuum-bake for 45 minutes at 80°C.
- (4) The resist-coated glass and the mask negative are placed in a carbon-arc exposure unit (Nu Arc Model FT18A). The glass is carefully aligned with the negative, with the unetched side against the negative. The resist is exposed for 3 minutes. Since the glass is transparent, the resist exposes on both sides of the glass.
- (5) The resist is developed in KMER developer for 2 minutes, and rinsed in running water for 30 seconds.
- (6) The glass is then placed in a vacuum oven at 80 to 85°C for 2-1/2 hours, to improve adhesion of the resist.
- (7) The resist on the glass is coated with black wax solution to within 1/8 inch of the perimeter of the pattern. The wax is dried for 15 minutes at 80°C.
- (8) The prepared glass is immersed in hydrofluoric acid. It is repeatedly etched for 1 minute, removed, and rinsed with distilled water, and inspected; until the etching is judged complete. An optical comparator or tool maker's microscope is used for the final inspection.
- (9) The black wax is removed with trichloroethylene, and the KMER removed with SK-4 stripper, and the mask is then washed in hot water. A completed mask is shown in Fig. 8.

## SECTION III

### PROBLEM AREAS IN THE PROCESS

While developing this process, and during the etching of the six masks which were measured, various problems were encountered. The more serious ones are discussed below with the immediate partial solutions, and suggestions for future work.

#### POOR ADHESION OF KMER TO GLASS

The adhesion varies from run to run. When the adhesion is poor, the KMER lifts before the etching of the glass is complete. Vacuum baking and the introduction of layers of black wax into the process reduce this problem somewhat. However, there is some difficulty in consistently baking the resist enough to make it adhere during etching, but not so much that it is very difficult to remove later. It may be worth experimenting with a layer of another material between the glass and the resist, particularly a material which can be etched by some chemical other than hydrofluoric acid and which is resistant to the latter. The use of chemically deposited silver for this purpose has been suggested.

Additives for KMER are also available, and are claimed to improve its adhesion to glass.

The MITRE Corporation has suggested that the KMER be stripped with boiling sulphuric acid as this would be more effective than using SK-4. This should allow baking the resist harder after developing, and still permit removal of the resist after etching.

#### DEPENDENCE OF ETCHING RATE ON ETCHED AREAS

Small areas appear to etch faster than large ones. Hence, a pattern with apertures of different widths will etch unevenly. This can be overcome by selective etching at the end of the etching process (i. e. , the faster-etching small areas are either kept out of the etch at the end, or masked off with wax). However, a more convenient approach would be to prepare the artwork in such a way that the larger area apertures are produced by etching lines around their borders, and that the line widths are standardized as much as possible.

#### DIFFICULTY IN DETERMINING COMPLETION OF ETCHING

As the glass is transparent, it is difficult to see when the etch has penetrated through the mask. The etching was continually interrupted to study the work under a microscope. If the etching conditions were sufficiently standardized, the operation could be timed.

## SECTION IV

### MEASUREMENTS ON SIX MASKS

Six masks were made by the process described. These masks and the photographic master used for exposing the resist were measured on a Wilder Micro Projector, Model D (see Tables I and II). The measurements were obtained at 100 x magnification. Three width measurements were noted for each resistor slot (see Fig. 11):

A = distance between parallel lines touching outside the aperture edges  
(maximum measurement);

B = distance between parallel lines touching inside the aperture edges  
(minimum measurement); and

C = estimated mean width of the aperture.

Note: The end 0.020 inch of each slot was ignored in the measurements to avoid corner radii affecting the width measurements.

The design width for the apertures was 0.0300 inch. The analysis in Table III indicates the departures obtained for each mask. The departures of the photographic master are included.

Table I

Measurements of Photographic Master Widths

Resistor	A(Max)	B(Min)	C(Mean)
R <sub>1</sub>	0.0316	0.0310	0.0306
R <sub>2</sub>	0.0320*	0.0310	0.0312
R <sub>3</sub>	0.0310	0.0304+	0.0306+
R <sub>4</sub>	0.0314	0.0308	0.0310
R <sub>5</sub>	0.0316	0.0308	0.0310
R <sub>6</sub>	0.0310	0.0308	0.0310
R <sub>7</sub>	0.0318	0.0312	0.0314*
R <sub>8</sub>	0.0308	0.0306	0.0306
R <sub>9</sub>	0.0309	0.0306	0.0308
R <sub>10</sub>	0.0312	0.0310	0.0310

\* = largest

+ = smallest

**Table II**  
**Measurements of Six Masks**

Mask I				Mask II			
Resistor	A(Max)	B(Min)	C(Mean)	Resistor	A(Max)	B(Min)	C(Mean)
R <sub>1</sub>	0.0338	0.0314	0.0322*	R <sub>1</sub>	0.0325	0.0270 <sup>+</sup>	0.0302 <sup>+</sup>
R <sub>2</sub>	0.0340*	0.0304	0.0311	R <sub>2</sub>	0.0342	0.0296	0.0322
R <sub>3</sub>	0.0326	0.0283	0.0300	R <sub>3</sub>	0.0350	0.0292	0.0323
R <sub>4</sub>	0.0331	0.0282 <sup>+</sup>	0.0294 <sup>+</sup>	R <sub>4</sub>	0.0336	0.0294	0.0324*
R <sub>5</sub>	0.0326	0.0293	0.0300	R <sub>5</sub>	0.0352	0.0304	0.0310
R <sub>6</sub>	0.0324	0.0312	0.0321	R <sub>6</sub>	0.0324	0.0290	0.0313
R <sub>7</sub>	0.0323	0.0303	0.0320	R <sub>7</sub>	0.0340	0.0298	0.0316
R <sub>8</sub>	0.0319	0.0301	0.0305	R <sub>8</sub>	0.0344	0.0288	0.0310
R <sub>9</sub>	0.0321	0.0304	0.0314	R <sub>9</sub>	0.0342	0.0298	0.0316
R <sub>10</sub>	0.0340*	0.0312	0.0320	R <sub>10</sub>	0.0368*	0.0299	0.0318
Mask III				Mask IV			
Resistor	A(Max)	B(Min)	C(Mean)	Resistor	A(Max)	B(Min)	C(Mean)
R <sub>1</sub>	0.0332	0.0304	0.0316	R <sub>1</sub>	0.0340	0.0308	0.0314
R <sub>2</sub>	0.0340*	0.0318	0.0324*	R <sub>2</sub>	0.0350*	0.0328	0.0316
R <sub>3</sub>	0.0338	0.0308	0.0310	R <sub>3</sub>	0.0342	0.0322	0.0312 <sup>+</sup>
R <sub>4</sub>	0.0326	0.0306	0.0312	R <sub>4</sub>	0.0350*	0.0330	0.0328
R <sub>5</sub>	0.0322	0.0300	0.0306 <sup>+</sup>	R <sub>5</sub>	0.0344	0.0326	0.0330
R <sub>6</sub>	0.0330	0.0308	0.0316	R <sub>6</sub>	0.0326	0.0304 <sup>+</sup>	0.0312
R <sub>7</sub>	0.0332	0.0314	0.0324*	R <sub>7</sub>	0.0322	0.0308	0.0320
R <sub>8</sub>	0.0326	0.0299	0.0316	R <sub>8</sub>	0.0334	0.0308	0.0320
R <sub>9</sub>	0.0324	0.0314	0.0318	R <sub>9</sub>	0.0342	0.0318	0.0334*
R <sub>10</sub>	0.0320	0.0298 <sup>+</sup>	0.0316	R <sub>10</sub>	0.0340	0.0320	0.0330
Mask V				Mask VI			
Resistor	A(Max)	B(Min)	C(Mean)	Resistor	A(Max)	B(Min)	C(Mean)
R <sub>1</sub>	0.0302	0.0260 <sup>+</sup>	0.0278 <sup>+</sup>	R <sub>1</sub>	0.0324	0.0310	0.0316 <sup>+</sup>
R <sub>2</sub>	0.0308*	0.0280	0.0300	R <sub>2</sub>	0.0344	0.0342	0.0340
R <sub>3</sub>	0.0306	0.0286	0.0298	R <sub>3</sub>	0.0342	0.0338	0.0336
R <sub>4</sub>	0.0304	0.0284	0.0300	R <sub>4</sub>	0.0348	0.0340	0.0336
R <sub>5</sub>	0.0304	0.0279	0.0294	R <sub>5</sub>	0.0330	0.0302 <sup>+</sup>	0.0320
R <sub>6</sub>	0.0304	0.0278	0.0296	R <sub>6</sub>	0.0346	0.0324	0.0330
R <sub>7</sub>	0.0308	0.0290	0.0301*	R <sub>7</sub>	0.0358*	0.0332	0.0342*
R <sub>8</sub>	0.0303	0.0294	0.0298	R <sub>8</sub>	0.0348	0.0326	0.0332
R <sub>9</sub>	0.0302	0.0278	0.0299	R <sub>9</sub>	0.0348	0.0320	0.0334
R <sub>10</sub>	0.0306	0.0296	0.0301*	R <sub>10</sub>	0.0340	0.0320	0.0334

\* - largest

• - smallest

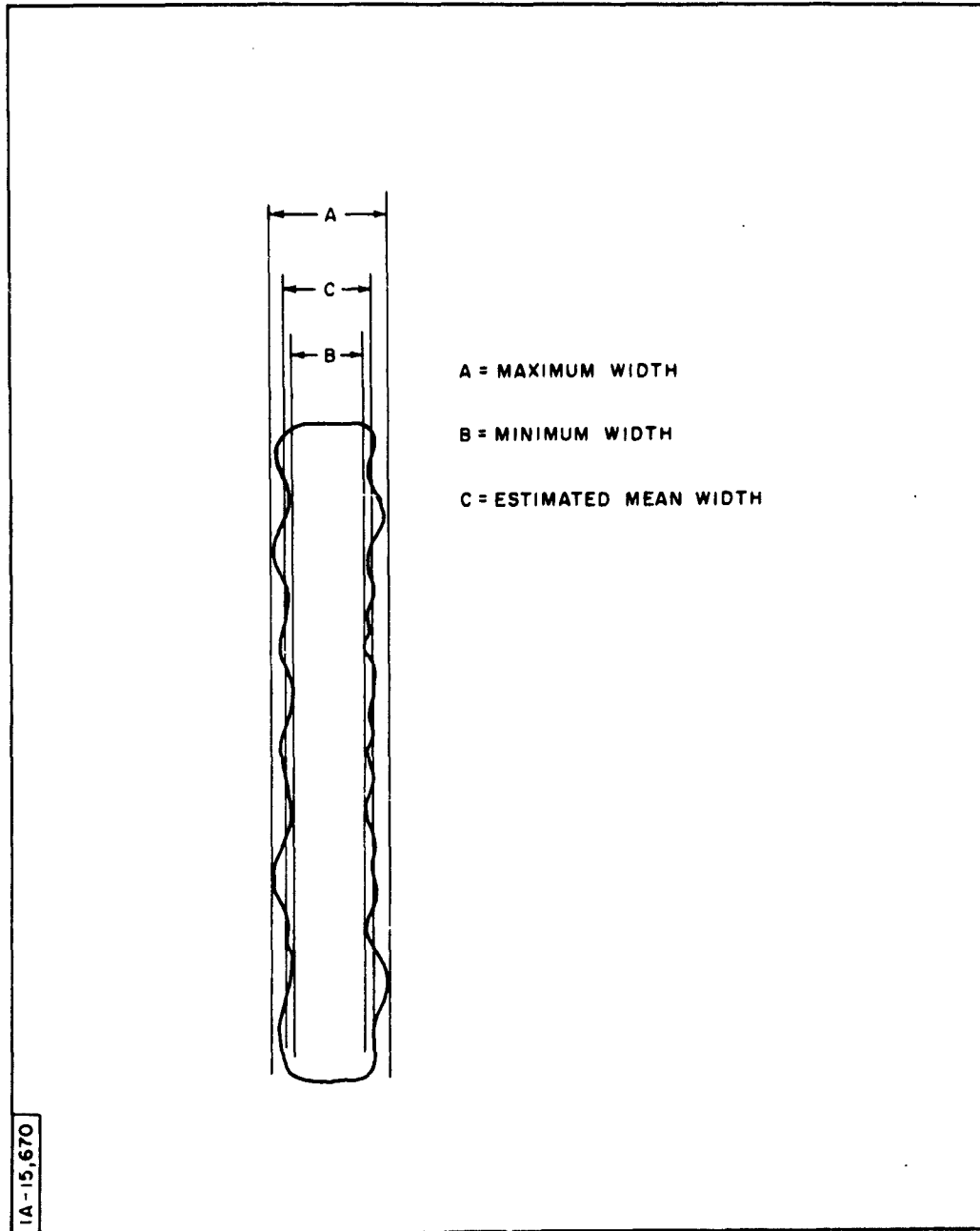

Fig. 11 Measurement Details (Irregularity of Aperture Is Exaggerated for Clarity)

Table III

Tolerances Obtained on Six Masks

Mask	Spread (in.)	Maximum Departure (in.)	Departure of Mean (in.)
Photographic Master	0.0016	0.0020	0.0014
I	0.0058	0.0040	0.0022
II	0.0098	0.0068	0.0024
III	0.0042	0.0040	0.0024
IV	0.0046	0.0050	0.0034
V	0.0048	0.0040	0.0022
VI	0.0056	0.0058	0.0042

Spread = spread of measurements (i. e. , max A - min B), inches.

Maximum departure = maximum departure from target width (0.0300), inches.

Departure of mean = maximum difference between C (the estimated mean value) for any aperture and the design width in inches.

## SECTION V

### CONCLUSIONS

Table III gives a summary of the tolerances obtained on the 6 masks processed. It appears that with this process, we can confidently expect the dimensional tolerances on aperture width to be within 0.007 inch of the design width and to have a reasonable yield within 0.004 inch. The value of a deposited resistor will be governed by the mean width of the aperture, rather than its worst measurement. For this reason, the mean width of each aperture was estimated, and included in Table II. The last column of Table III shows the maximum departure of this estimated mean from the design width. This departure was, in all cases, within 0.005 inch, and, generally, within 0.0025 inch. On the better masks, the artwork and photography accounted for about one-half of the error.

These results indicate that, in its present state of development, the process results in errors appreciably greater than those expected with good stainless steel masks, 0.002-inch thick, using existing processes. However, the masks produced are good enough for evaluating the new method of resistance monitoring. If the direct resistance monitoring method proves to be feasible, the glass etching process would be worth developing for greater accuracy.

  
Patrick Everett

  
Richard Roderick

## REFERENCES

1. Bell, J. The Design and Fabrication of High Speed, Hybrid Microcircuits, MITRE Working Paper No. 6578.
2. Bell, J. The Fabrication of Stainless Steel Evaporation Masks for Vacuum-Deposited Thin Films, MITRE Working Paper No. 6580.

Security Classification

**DOCUMENT CONTROL DATA - R&D**

*(Security classification of title, body of abstract and indexing annotation must be entered when the overall report is classified)*

1 ORIGINATING ACTIVITY (Corporate author)  The MITRE Corporation Bedford, Massachusetts		2a REPORT SECURITY CLASSIFICATION <b>Unclassified</b>	
		2b GROUP	
3 REPORT TITLE  Fabrication of Glass Masks, and Their Application to Thin Film Circuit Deposition			
4 DESCRIPTIVE NOTES (Type of report and inclusive dates)  N. A.			
5 AUTHOR(S) (Last name, first name, initial)  Everett, Patrick and Roderick, Richard			
6. REPORT DATE  May 1965		7a. TOTAL NO. OF PAGES  24	7b. NO. OF REFS  2
8a. CONTRACT OR GRANT NO.  AF 19(628)-2390		8a. ORIGINATOR'S REPORT NUMBER(S)  ESD-TDR-64-634	
b. PROJECT NO.  508		8b. OTHER REPORT NO(S) (Any other numbers that may be assigned this report)  W-06760	
c			
d			
10. AVAILABILITY/LIMITATION NOTICES  Qualified requestors may obtain from DDC. DDC release to OTS not authorized.			
11. SUPPLEMENTARY NOTES		12. SPONSORING MILITARY ACTIVITY  Directorate of Computers Electronic Systems Division, L. G. Hanscom Field, Bedford Mass.	
13 ABSTRACT  This report describes a process which has been developed for the etching of glass masks. A discussion of the requirements for these masks in thin-film circuit deposition precedes a detailed description of the process.  Six masks were produced by the process, and measurements were made to determine the tolerances obtained.			

14 KEY WORDS	LINK A		LINK B		LINK C	
	ROLE	WT	ROLE	WT	ROLE	WT
THIN FILMS						
SEMICONDUCTING FILMS						
PRINTED CIRCUITS						
INTEGRATED CIRCUITS						

**INSTRUCTIONS**

1. **ORIGINATING ACTIVITY:** Enter the name and address of the contractor, subcontractor, grantee, Department of Defense activity or other organization (*corporate author*) issuing the report.

2a. **REPORT SECURITY CLASSIFICATION:** Enter the overall security classification of the report. Indicate whether "Restricted Data" is included. Marking is to be in accordance with appropriate security regulations.

2b. **GROUP:** Automatic downgrading is specified in DoD Directive 5200.10 and Armed Forces Industrial Manual. Enter the group number. Also, when applicable, show that optional markings have been used for Group 3 and Group 4 as authorized.

3. **REPORT TITLE:** Enter the complete report title in all capital letters. Titles in all cases should be unclassified. If a meaningful title cannot be selected without classification, show title classification in all capitals in parenthesis immediately following the title.

4. **DESCRIPTIVE NOTES:** If appropriate, enter the type of report, e.g., interim, progress, summary, annual, or final. Give the inclusive dates when a specific reporting period is covered.

5. **AUTHOR(S):** Enter the name(s) of author(s) as shown on or in the report. Enter: last name, first name, middle initial. If military, show rank and branch of service. The name of the principal author is an absolute minimum requirement.

6. **REPORT DATE:** Enter the date of the report as day, month, year, or month, year. If more than one date appears on the report, use date of publication.

7a. **TOTAL NUMBER OF PAGES:** The total page count should follow normal pagination procedures, i.e., enter the number of pages containing information.

7b. **NUMBER OF REFERENCES:** Enter the total number of references cited in the report.

8a. **CONTRACT OR GRANT NUMBER:** If appropriate, enter the applicable number of the contract or grant under which the report was written.

8b, 8c, & 8d. **PROJECT NUMBER:** Enter the appropriate military department identification, such as project number, subproject number, system numbers, task number, etc.

9a. **ORIGINATOR'S REPORT NUMBER(S):** Enter the official report number by which the document will be identified and controlled by the originating activity. This number must be unique to this report.

9b. **OTHER REPORT NUMBER(S):** If the report has been assigned any other report numbers (*either by the originator or by the sponsor*), also enter this number(s).

10. **AVAILABILITY/LIMITATION NOTICES:** Enter any limitations on further dissemination of the report, other than those

imposed by security classification, using standard statements such as:

- (1) "Qualified requesters may obtain copies of this report from DDC."
- (2) "Foreign announcement and dissemination of this report by DDC is not authorized."
- (3) "U. S. Government agencies may obtain copies of this report directly from DDC. Other qualified DDC users shall request through \_\_\_\_\_."
- (4) "U. S. military agencies may obtain copies of this report directly from DDC. Other qualified users shall request through \_\_\_\_\_."
- (5) "All distribution of this report is controlled. Qualified DDC users shall request through \_\_\_\_\_."

If the report has been furnished to the Office of Technical Services, Department of Commerce, for sale to the public, indicate this fact and enter the price, if known.

11. **SUPPLEMENTARY NOTES:** Use for additional explanatory notes.

12. **SPONSORING MILITARY ACTIVITY:** Enter the name of the departmental project office or laboratory sponsoring (*paying for*) the research and development. Include address.

13. **ABSTRACT:** Enter an abstract giving a brief and factual summary of the document indicative of the report, even though it may also appear elsewhere in the body of the technical report. If additional space is required, a continuation sheet shall be attached.

It is highly desirable that the abstract of classified reports be unclassified. Each paragraph of the abstract shall end with an indication of the military security classification of the information in the paragraph, represented as (TS), (S), (C), or (U).

There is no limitation on the length of the abstract. However, the suggested length is from 150 to 225 words.

14. **KEY WORDS:** Key words are technically meaningful terms or short phrases that characterize a report and may be used as index entries for cataloging the report. Key words must be selected so that no security classification is required. Identifiers, such as equipment model designation, trade name, military project code name, geographic location, may be used as key words but will be followed by an indication of technical content. The assignment of links, rules, and weights is optional.