

COPY TL

1-BPL

Ref # 68793
(24 Apr 65)

64054

NOVEMBER
1964

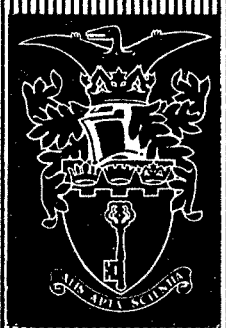

ROYAL AIRCRAFT ESTABLISHMENT
TECHNICAL REPORT No. 64054

Prepared by:
STANDARDIZATION GROUP
UNIT
RAN 100 W.C., New York, N.Y. 09399.

**DIGITAL MAGNETIC
TAPE UNITS FOR
THE MERCURY AND
DEUCE COMPUTERS**

PART 2 - CONTROL CIRCUITS

by
K. Sanderson
P. D. M. Thane

TECHNICAL LIBRARY
BLDG 313
ABERDEEN PROVING GROUND MD.
STEAP-TL

PRINTED IN

20061031448

RFE
TR-64054

MINISTRY OF AVIATION
FARNBOROUGH HANTS

THE RECIPIENT IS WARNED THAT INFORMATION
CONTAINED IN THIS DOCUMENT MAY BE SUBJECT
TO PRIVATELY-OWNED RIGHTS.

R-68793

NOV 12 1965

U.D.C. No. 681.14 : 621.374.32 : 681.177.5

R O Y A L A I R C R A F T E S T A B L I S H M E N T

Technical Report No.64054

November 1964

DIGITAL MAGNETIC TAPE UNITS FOR THE
MERCURY AND DEUCE COMPUTERS

Part 2 - Control circuits

by

K. Sanderson

P. D. M. Thane

SUMMARY

This part describes the function and format selection circuits, the circuits controlling tape drive and tape spooling, and the power supplies.

TECHNICAL LIBRARY
BLDG. 313
ABERDEEN PROVING GROUND, MD.
STEAP-TL

Departmental Reference: Maths 128

TECHNICAL LIBRARY
BLDG. 313
ABERDEEN PROVING GROUND MD.
STEAP-TL

CONTENTS

	<u>Page</u>
1 GENERAL INTRODUCTION	3
2 INTRODUCTION TO PART 2	3
3 FUNCTION AND FORMAT SELECTION	3
4 TAPE DRIVE AND TAPE SPOOLING	4
4.1 Drive mode	4
4.2 Tape spooling in the drive mode	6
4.3 Auto-Stop	6
4.4 Wind mode	7
4.5 Protection circuits	8
5 POWER SUPPLIES	9
References	10
Illustrations	Figures 1-25
Detachable abstract cards	-

ILLUSTRATIONS

	<u>Fig.</u>
Layout of major components	1
Logic symbols	2
Function and format selection	3
Circuit board 61 - erase oscillator	4
Control panel	5
Tape drive and tape spooling components	6
Tape drive and tape wind control circuit	7
Tape spooling in the drive mode	8
Spooling servo interconnections	9
Tape spooling in the wind (forward) mode	10
Power unit	11
+10V stabiliser unit	12
20V stabiliser unit	13
-6V stabiliser unit	14
-15V stabiliser unit	15
Circuit board 1-7A	16
Circuit board 1-7B	17
Circuit board 1-7C	18
Circuit board 36	19
Circuit board 53-54	20
Circuit board 56	21
Circuit board 57	22
Circuit board 58	23
Circuit board 59	24
Wiring diagram - Box "D"	25

1 GENERAL INTRODUCTION

Magnetic tape input and output facilities for the Mercury and Deuce computers in Mathematics Dept^{1,2} use the same type of equipment, which has been variously described as the N.E.P., M.P.L. or Honeywell digital magnetic tape unit. This provides facilities for reading and writing 5 or 8-bit characters, using $\frac{1}{2}$ inch wide magnetic tape as the recording medium. Used "on-line" with the computers, the maximum input or output rate is about 850 characters per second. "Off-line" the unit can be operated at character rates appropriate to a paper tape reader, paper tape punch or teleprinter.

The units, four in number, have been subject to considerable development and modification in the course of a lengthy commissioning process. The first phase consisted largely in installing agreed modifications and was carried out by the manufacturer's engineers. The second phase was carried out by Mathematics Dept. At the beginning of the second phase, the four units differed in detail logical and circuit design; documentation was either non-existent or inaccurate; day-to-day serviceability was unpredictable, mostly due to damage to electronic circuit packages occasioned by the use of an unsuitable type of printed circuit connector.

This Report records the knowledge acquired in bringing the four units to a common, reliable, specified standard suitable for foreseeable applications with the Mercury and Deuce computers. For reader convenience, the Report is divided into three parts:-

Part 1 - General characteristics and operation

Part 2 - Control circuits

Part 3 - Logical operation.

2 INTRODUCTION TO PART 2

This part is concerned with function and format selection, the circuits controlling tape movement and power supplies. The major components involved are shown in Fig.1; the associated electronic circuits are located in Box "D" at the rear of the unit. The logic symbol conventions used throughout are shown in Fig.2.

3 FUNCTION AND FORMAT SELECTION

The primary function selection is READ or WRITE; subsidiary function selections are DRIVE CC or DRIVE CONT. and HIGH Z or LOW Z. Format selection for read or write operations is "5", "8" or "N" (Normal). The purpose of the

various functions and formats is outlined in Part 1; their effect on the logical interconnections of the read and write circuits is given in detail in Part 3.

Fig.3 shows the selection circuit. The control lines corresponding to each function or format have the potential 0V when not selected, or -6V when selected. Relay RL.12 which selects the READ or WRITE functions is controlled by the Read/Write push-button via relays RL.A and RL.B, forming a relay "scale-of-two" circuit. Assume that RL.A and RL.B are de-energised, then RL.12 will also be de-energised, therefore READ is selected. Subsequently, when the push-button is operated (depressed), RL.A is energised; when the push-button is released, RL.B becomes energised. Contact RL.B/3 energises RL.12 to select the WRITE function and also switches-on the Erase Oscillator. Contact RL.B/4 inhibits drive back operation (Section 4) when WRITE is selected, to guard against accidental erasure of a recording on the tape. A further subsequent operation of the push-button de-energises RL.A which allows RL.B to become de-energised when the push-button is released. Thus successive operations of the push-button selects READ and WRITE alternately.

The circuit always assumes the READ state when the unit is first switched-on. Also the circuit automatically reverts to the READ state whenever the tape transport door is opened, a subsequent operation of the push-button is then required to re-select WRITE. These measures to some extent safeguard recordings on the tape against accidental erasure.

The Erase Oscillator circuit is shown in Fig.4 and the full Control Panel circuit in Fig.5.

4 TAPE DRIVE AND TAPE SPOOLING

A simplified general arrangement of the tape drive and spooling components is shown in Fig.6. The corresponding control interconnections are shown in Fig.7. Primary control modes are DRIVE for read/write operations and WIND for fast spooling in either direction. In the DRIVE mode, the tape is capstan driven; supply and take-up spools are servo-controlled to keep the tape tension approximately constant. In the WIND mode, the tape is driven by one or other of the spooling motors; one tape spool is rotated at constant speed, the other is servo-controlled to keep the tape tension approximately constant.

4.1 Drive mode

The tape may be driven at capstan speed either by push-button control in the forward or backward directions (forward only, when WRITE is selected) or under electronic control from the read/write control circuits (Part 3) in the

forward direction only. Counter-rotating forward drive and back drive capstans rotate continuously; the tape is driven when pressed against one or other of the capstans by means of pinch rollers. Capstan drive is by synchronous motor through a four speed gear-box, giving nominal tape speeds of 1/8, 5/8, 1.6 and 10 inches/second. The required gear ratio is selected by switching a pair of solenoid operated spring clutches.

The forward drive pinch roller and associated forward brake are operated by fast-acting torque motors; the back drive pinch roller, the associated back brake and also the read/write head are solenoid operated. Torque motors and solenoids are arranged so that the pinch rollers and brakes are held off and the read/write head is held up, when output terminal Z of the appropriate control amplifier is at earth potential. Under normal conditions, this occurs when relays RL.6 and RL.7 are de-energised by selecting the WIND mode, or when any one of the control amplifier (or-gate) inputs is negative.

A flip-flop (Control "B") in the read/write control circuit, controls tape drive for read or write operations. The set state of Control "B" corresponds to tape drive energised; the reset state corresponds to tape drive de-energised. Under normal conditions, with DRIVE selected, "Inv. Drive" is at or above earth potential. Therefore, push-button or Control "B" inputs put forward drive, back drive or back brake on as required, the interconnections M.52, M.53 and M.55 forcing one of the following sets of conditions.

Table 1

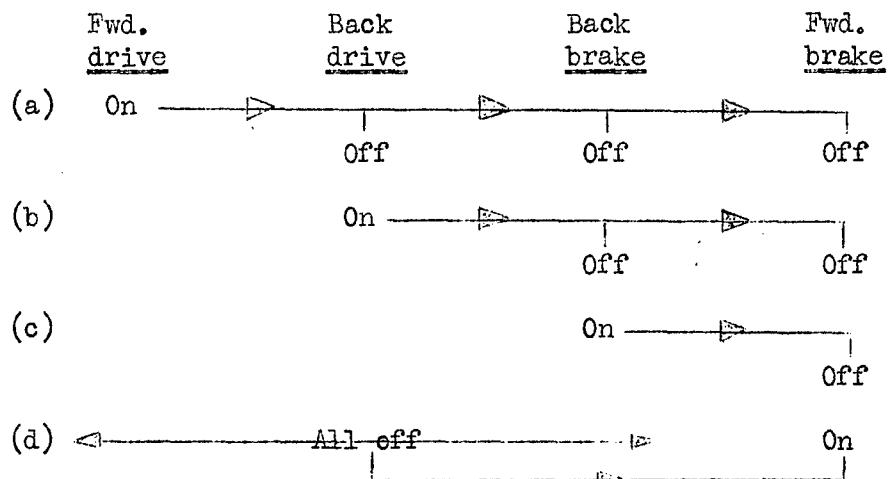

(a) Forward drive is energised when the Drive Fwd. push-button is operated or when Control "B" is set (Inv. Control "B" at earth potential).

(b) Back drive is energised when the Drive Back push-button is operated, provided that READ is selected. This provision safeguards recordings on the

tape, since the erase oscillator is switched-on whenever WRITE is selected.

(a) overrides (b), therefore if both drive push-buttons are operated together, the tape will be driven in the forward direction.

(c) The back brake is energised for a brief interval only, when the Drive Back push-button is released. The duration of the braking period is the time taken for the potential of M.10 to fall from +10V to about -3V. Both (a) and (b) override (c).

4.2 Tape spooling in the DRIVE mode

A simplified diagram of the spooling servo connections in the DRIVE mode is shown in Fig.8. (A complete diagram of the servo interconnections is shown in Fig.9.)

Individual split-field dc spooling motors drive the supply and take-up spools. Motor field current is supplied in push-pull by a servo amplifier; the magnitude and polarity of the motor field and hence motor torque, (since the armature is supplied with a constant current), depends on the magnitude and polarity of the difference between the two inputs to the amplifier. One input is a voltage proportional to displacement of a tape tensioning roller; the other is a voltage proportional to motor speed, derived from a dc tachogenerator mechanically coupled to the motor.

When the tape is driven by the forward drive capstan as shown, the upper tape tensioning roller drops and the lower one rises, thus applying a positive voltage input to the upper servo-amplifier and a negative voltage input to the lower servo-amplifier. These inputs cause the spooling motors to rotate in the directions shown, which tends to restore the tape tensioning rollers to their original positions and apply voltage negative feedback proportional to motor speed to the amplifiers via stabilising networks. Variations in tape tension are kept within about $\pm 10\%$ by making the tensioning springs long in comparison with the movement of the tensioning arm.

4.3 Auto-Stop

Under normal conditions in the DRIVE mode, Inv. Drive is positive and the read/write head position is controlled by the flip-flop Auto-Stop; the head is down when Auto-Stop is reset and vice versa. Set and reset potentials are generated by the passage of end stop contacts on the tape across upper and lower auto-stop posts respectively. (The end stop contacts consists of silver paper about $\frac{1}{2}$ inch long glued to the tape about 20 feet from each end. "Start" and "finish" end stop contacts are placed on opposite surfaces of the tape such that

the "start" contact operates the right-hand pair of auto-stop posts and the "finish" contact operates the left-hand pair.

When an end-stop contact overruns the auto-stop posts, Auto-Stop is set, which puts the read/write head up and holds the flip-flop Control "B" reset, disabling control of tape drive from the read/write control circuit. Push-button control of tape drive remains effective; either the tape can be wound off the spool completely or normal conditions can be restored by causing the end-stop contact to re-traverse the auto-stop posts, resetting Auto-Stop.

Auto-Stop is also used to terminate, automatically, WIND operation at the ends of the tape (Section 4.4).

4.4 Wind mode

Starting Control (Figs.7 and 9) - Selection of WIND FORWARD or WIND BACK energises either relay RL.8 or RL.4 respectively, and also de-energises relays RL.6 and RL.7, which hold Inv. Drive negative, both capstan drives off, both brakes off and the read/write head up.

Consider WIND FORWARD operation. Relay RL.8 is energised, therefore if READ is selected and the flip-flop Auto-Stop is not set, the wind relay (RL.1, Circuit Board 54) is energised. Contact RL.1/2 energises the auxiliary wind relays RL.2 and RL.3 to switch the spooling servo connections from the drive configuration of Fig.8 to the wind forward configuration of Fig.10. Note for further reference that contact RL.3/1 now augments RL.7/3 in controlling Inv. Drive.

Upper Servo Operation (Wind Forward) - Contact RL.1/1 disconnects the negative supply to the upper transducer, causing the upper spooling motor to accelerate to a constant speed determined by the (74K) feedback resistor; acceleration is controlled by the integrating network interposed between transducer and amplifier. Relay RL.C is energised from the tacho-generator as the motor runs up to speed. (The function of contact RL.C/1 is explained in the next paragraph.) At full speed, the upper tape tensioning arm rests against its limit switch buffer spring; operation of the limit switch is prevented by contact RL.8/1.

When the wind relay RL.1 is de-energised, contact RL.1/1 restores the negative supply to the upper transducer causing the upper spooling motor to decelerate. Contact RL.C/1 ensures that relays RL.2 and RL.3 are held energised i.e. the wind forward configuration of the servos is retained and Inv. Drive is

held negative, until the tacho-generator voltage has fallen to a value corresponding to a tape speed of about 10 inches/second.

Lower Servo Operation (Wind Forward) - Tape tension is controlled by the lower servo in the usual manner except that, the servo sensitivity is reduced by additional attenuation of the transducer output and the feedback from the tacho-generator is effective only during transient speed variations.

Stopping Control - Under normal conditions, the wind operation is stopped by de-energising RL.1. Two possibilities arise:-

(a) DRIVE is selected; RL.1 is then de-energised via contact RL.8/2. Relays RL.6 and RL.7 remove the hold-off contacts on capstans and brakes, and the hold-up contact on the read/write head. However none of these can be operated since Inv. Drive is held negative by contact RL.3/1 until relay RL.C is de-energised when the tape speed has fallen to about 10 inches/second. Relays RL.2 and RL.3 then switch the servos back to the drive configuration and allow Inv. Drive to go positive. Inv. Drive positive puts the read/write head down and restores control according to Table 1. Normally, in the absence of push-button or Control "B" inputs, the forward brake is applied.

(b) An end stop contact on the tape overruns the auto-stop posts, setting the flip-flop Auto-Stop. RL.1 is then de-energised via Inv. Auto-Stop. As before, relays RL.2 and RL.3 switch the servos back to the drive configuration when the tape speed has fallen to about 10 inches/second. However, since RL.6 and RL.7 are de-energised, all drive control is inhibited and the read/write head remains up. Selection of DRIVE restores push-button control of tape drive, but electronic control from the read/write control circuit is inhibited by Auto-Stop which holds the flip-flop Control "B" reset. The tape can then be wound off the spool completely or normal conditions can be restored by causing the end-stop contact to re-traverse the auto-stop post, resetting Auto-Stop, which allows the read/write head to resume the down position.

Tape Speed - Tape speed when spooling varies according to the amount of tape on the driving spool. Wind or rewind time for a full spool (1800 ft) of tape is about 6 minutes. The mean speed therefore is approximately 60 inches/second; the speed range is some 30-90 inches/second.

4.5 Protection circuits (Fig.7)

Door Switch - Opening the door of the tape transport causes the protection relay RL.9 to be energised. Contact RL.9/2 de-energises relays RL.6 and RL.7 to put Inv. Drive negative, both drives off, both brakes off and the read/write

head up. Electronic control of tape drive from the read/write control circuit is disabled, but push-button control remains effective, since operation of either push-button de-energises relay RL.9 temporarily via M.13. Contact RL.9/1 disconnects the -15V supply to the servo amplifiers to inhibit wind operation.

Limit Switches - The protection relay RL.9 is also energised if one of the limit switches becomes closed. This occurs either if one of the tape tensioning arms drops due to tape breakage or if one of the arms rises with sufficient force (due to severe snatch) to overcome a buffer spring. Normally, the door will be closed, therefore contact RL.9/3 energises relay RL.5 which puts a hold contact RL.5/1 across the limit switches. This prevents the protection relay from being energised and de-energised repeatedly. When the door is opened, relay RL.5 is de-energised, the hold contact RL.5/1 being substituted by the door switch. The normal condition (RL.9 de-energised) is re-stored on closing the door.

5 POWER SUPPLIES

The circuit of the power unit is shown in Fig.11. Mains power is applied initially to the main fan motor and transformer T.1 only. T.1 provides +10V, -6V and -15V supplies via individual stabiliser units (Figs.12, 14 and 15). At this point in time, only the +10V supply is connected to the external load. The +10V supply energises relay RL.1 to apply power to transformer T.2, which provides a 20V supply via a stabiliser unit (Fig.13) and an unstabilised supply at -28V. The positive end of the 20V supply is connected to +10V, to form the $\pm 10V$ supply for the tape tensioning arm transducers. The -28V supply energises relay RL.2 which connects the -6V and -15V supplies to the external load and switches-on the gear-box synchronous motor, the tape compartment blower and the choke-controlled, constant current armature supplies for the tape spooling motors.

The input current is approximately 2A at 230V, 50 c/s.

An auxiliary supply at +3V is derived from the +10V supply. The circuit is shown in Fig.24

REFERENCES

<u>No.</u>	<u>Author</u>	<u>Title, etc</u>
1	K. Sanderson	Magnetic tape input and output for the computer DEUCE. R.A.E. Tech. Note No. Math 115, August 1964
2	K. Sanderson I.B. Piggott P.D.M. Thane	An input/output selection system for the Mercury computer. R.A.E. Technical Report No.64.052, November 1964

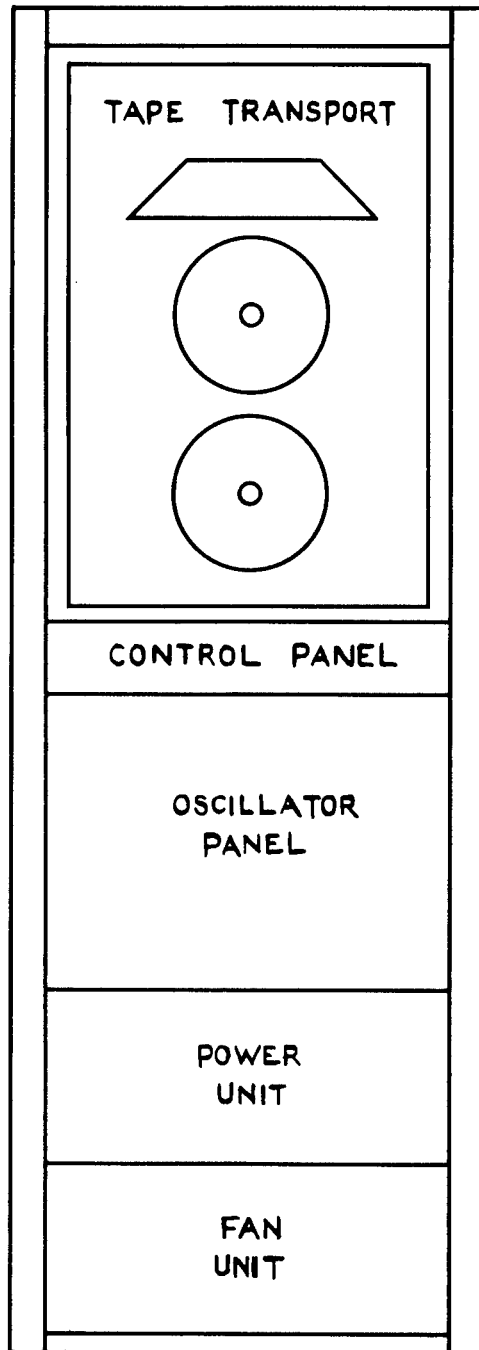
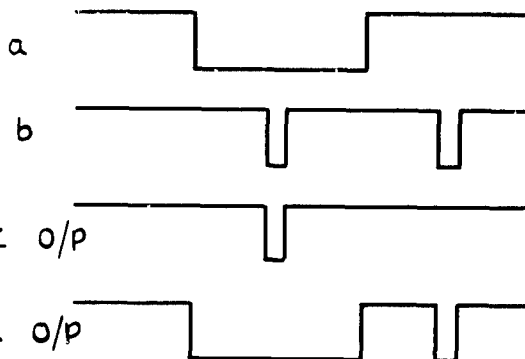
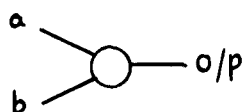
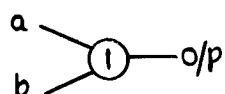

FIG. 1 LAYOUT OF MAJOR COMPONENTS

"AND" GATE



"OR" GATE



EMITTER-FOLLOWER



INVERTER-AMPLIFIER



FLIP-FLOP

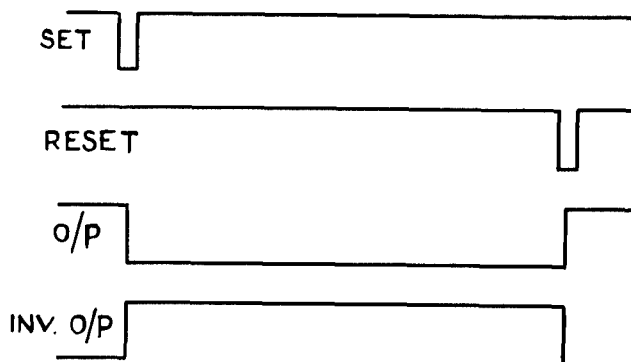
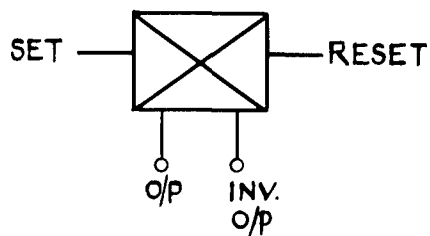

FIG.2 LOGIC SYMBOLS

Fig.3

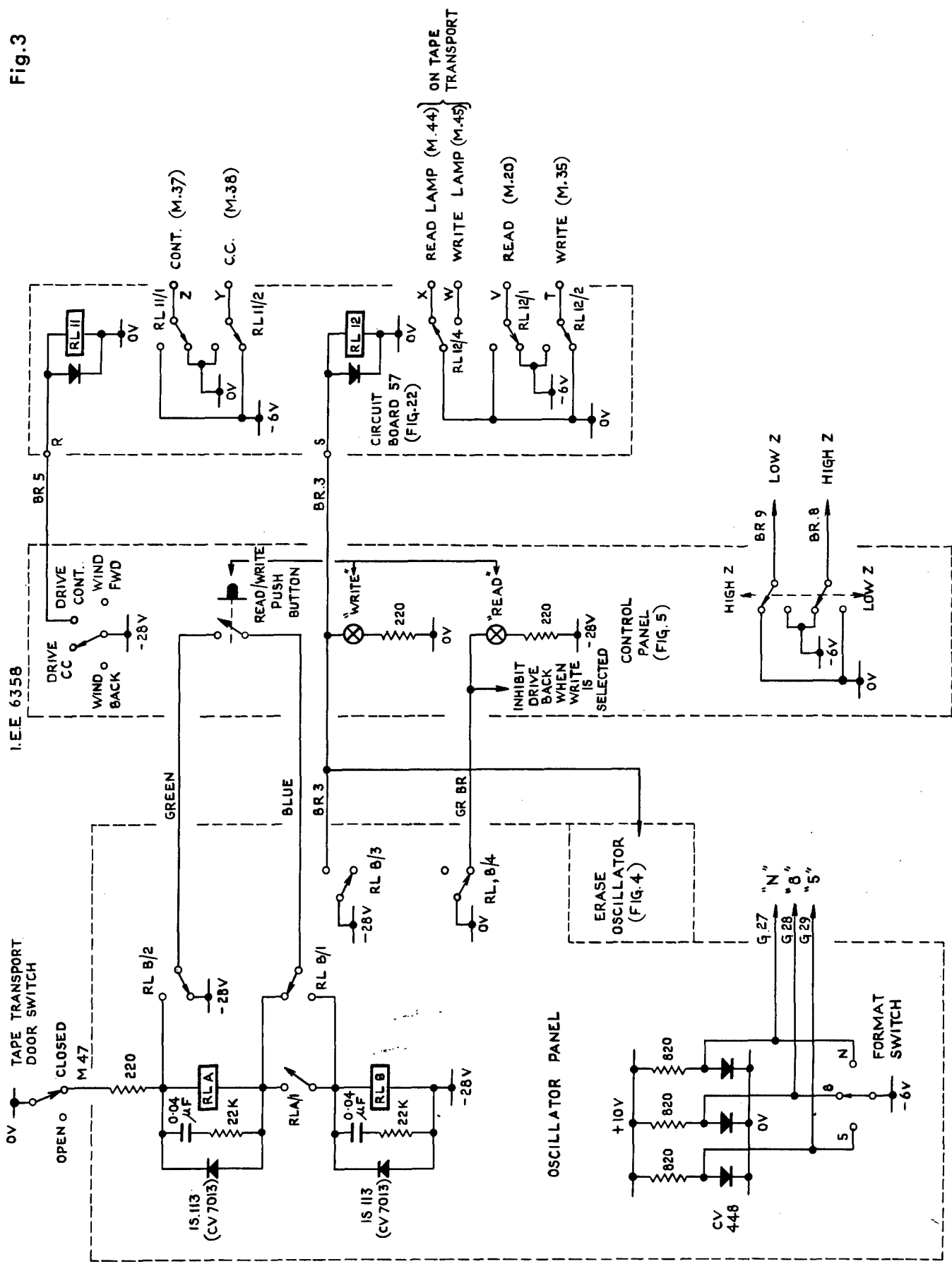

FIG. 3 FUNCTION AND FORMAT SELECTION

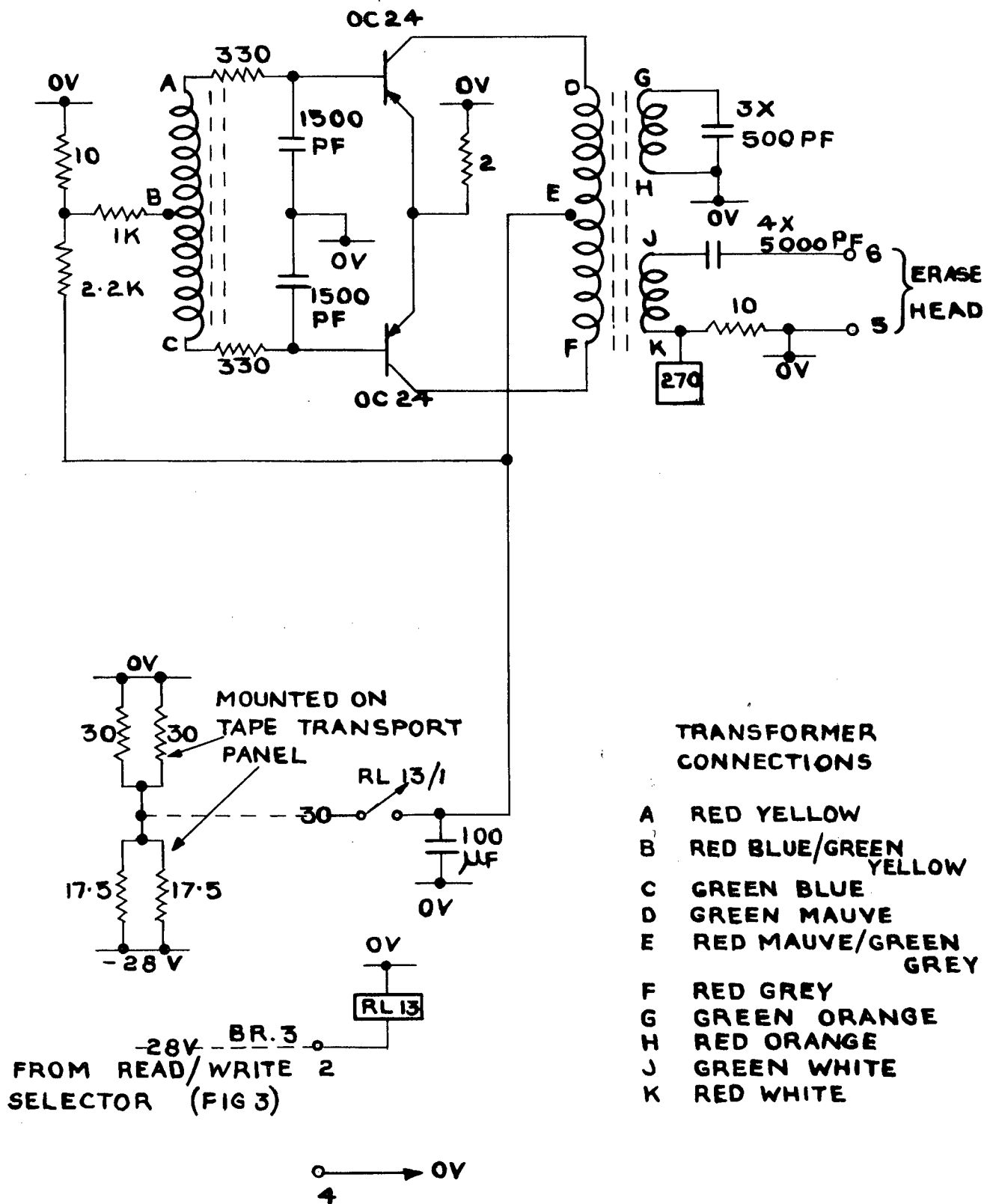

FIG. 4 CIRCUIT BOARD 61 (ERASE OSCILLATOR)

Fig.5

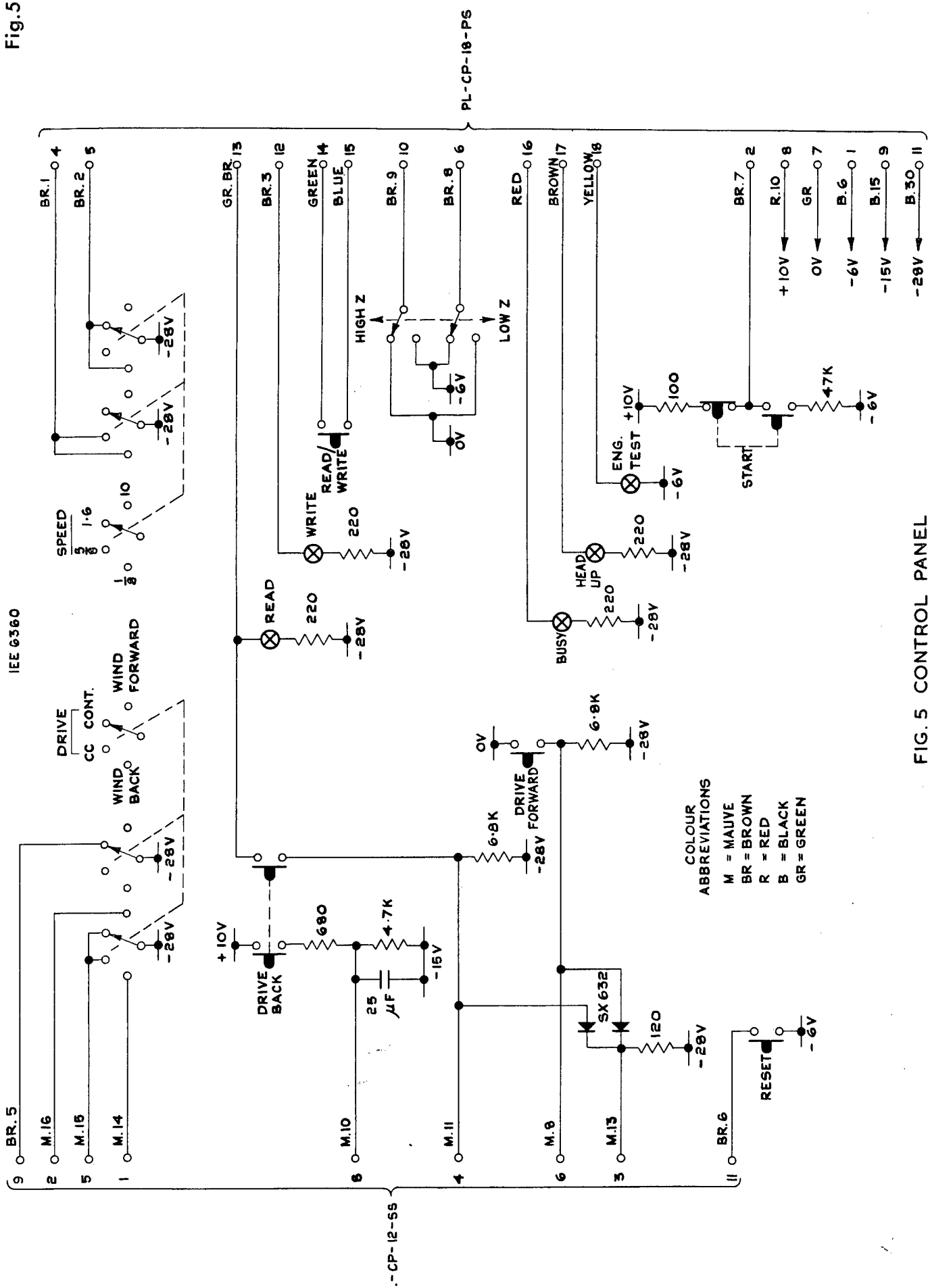

FIG. 5 CONTROL PANEL

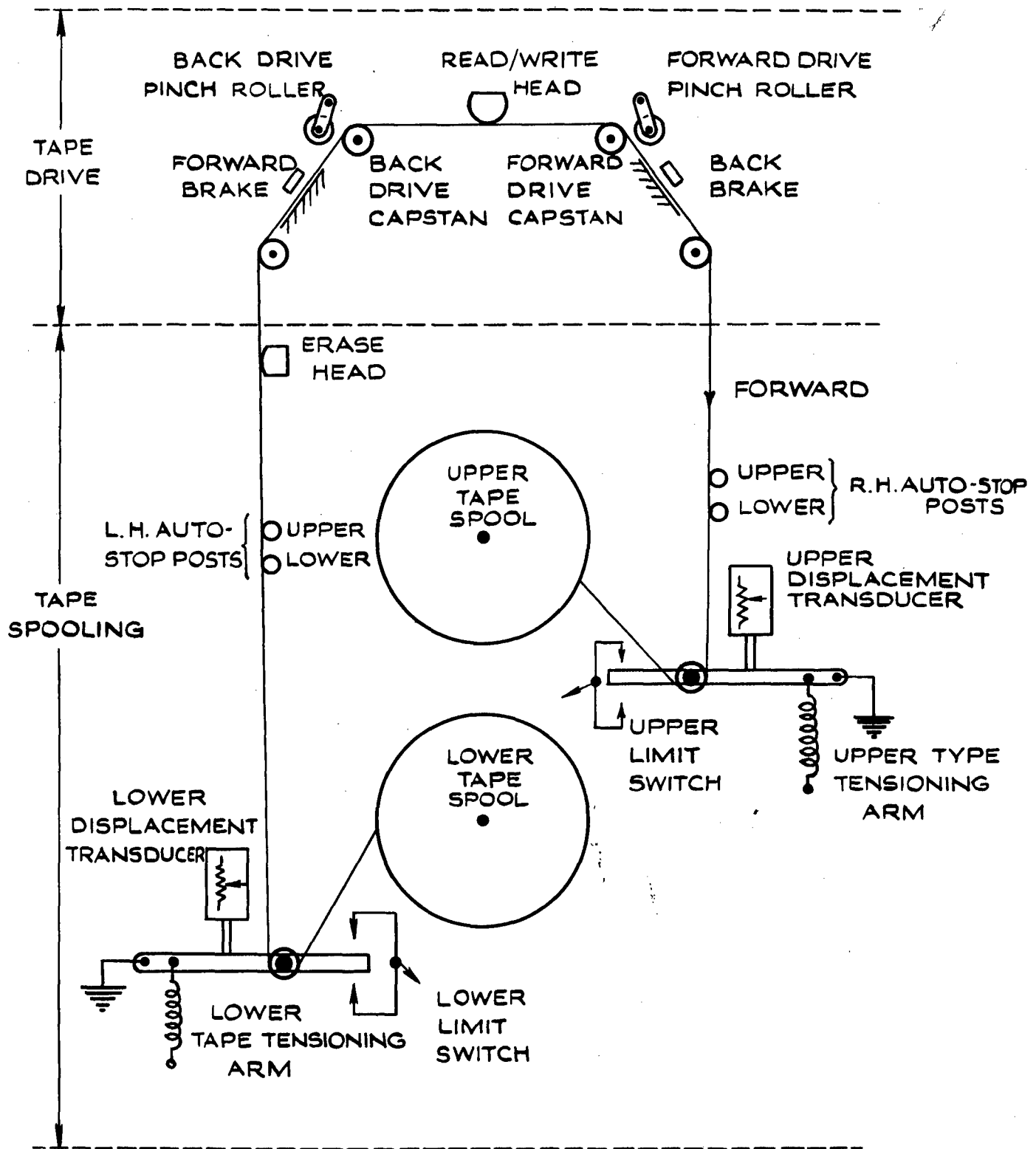

FIG.6 TAPE DRIVE AND TAPE SPOOLING COMPONENTS

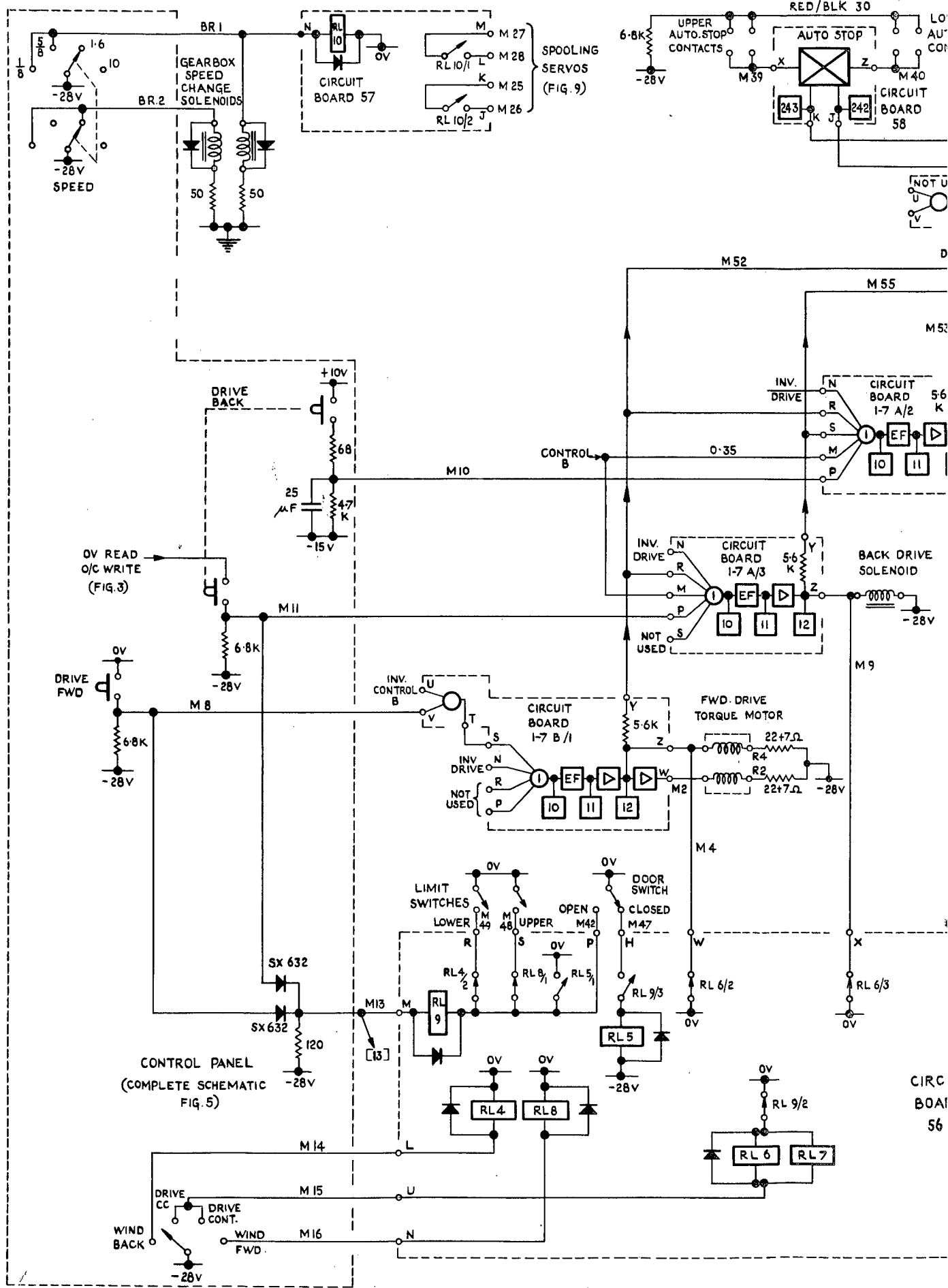
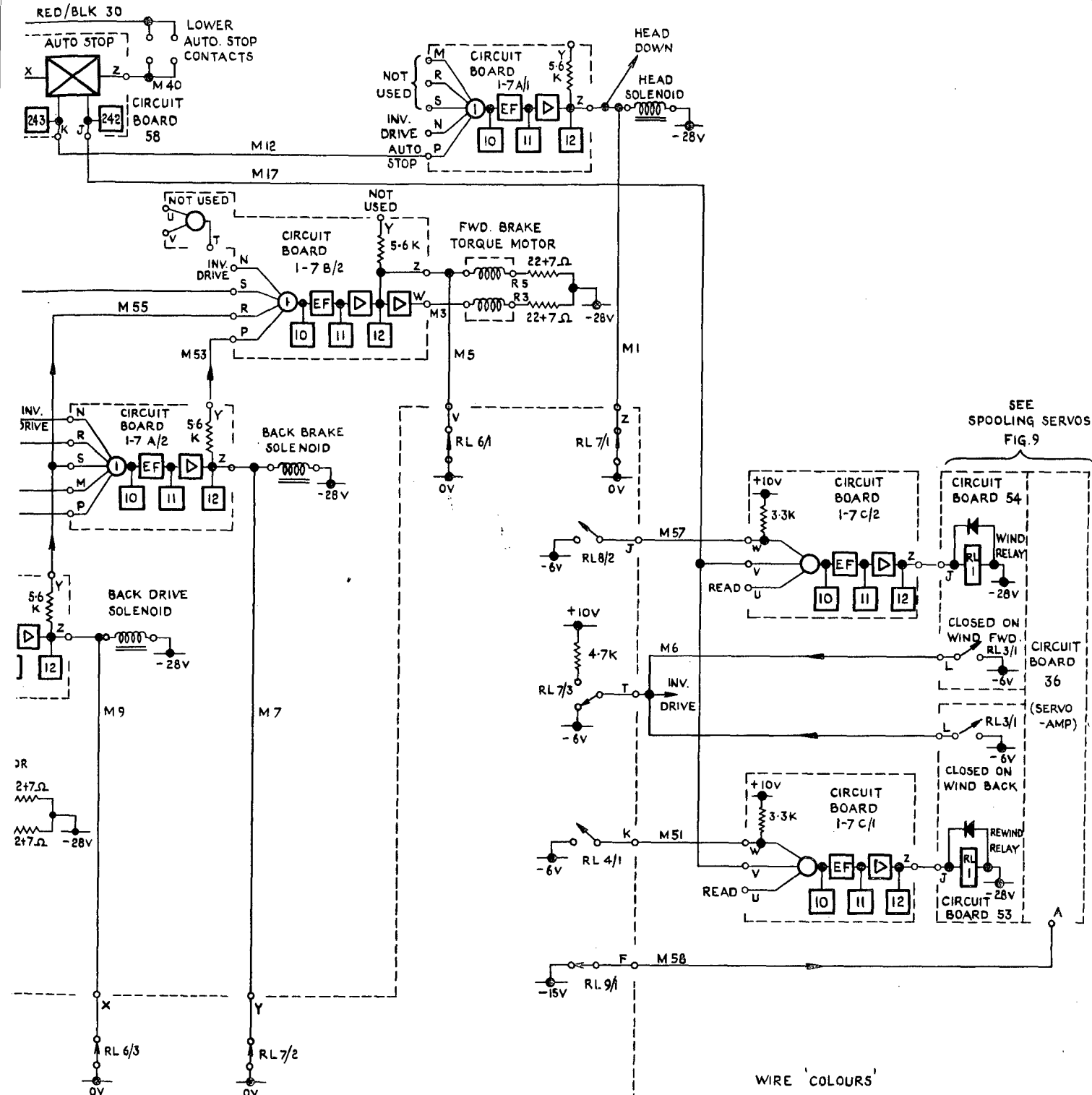

FIG. 7 TAPE DRIVE AND TAPE V

IEE. 6362



WIRE 'COLOURS'

- M = MAUVE
- O = ORANGE
- BR = BROWN
- R = RED

ALL RELAYS ARE UN-ENERGISED

ALL DIODES CV 448 EXCEPT WHERE INDICATED

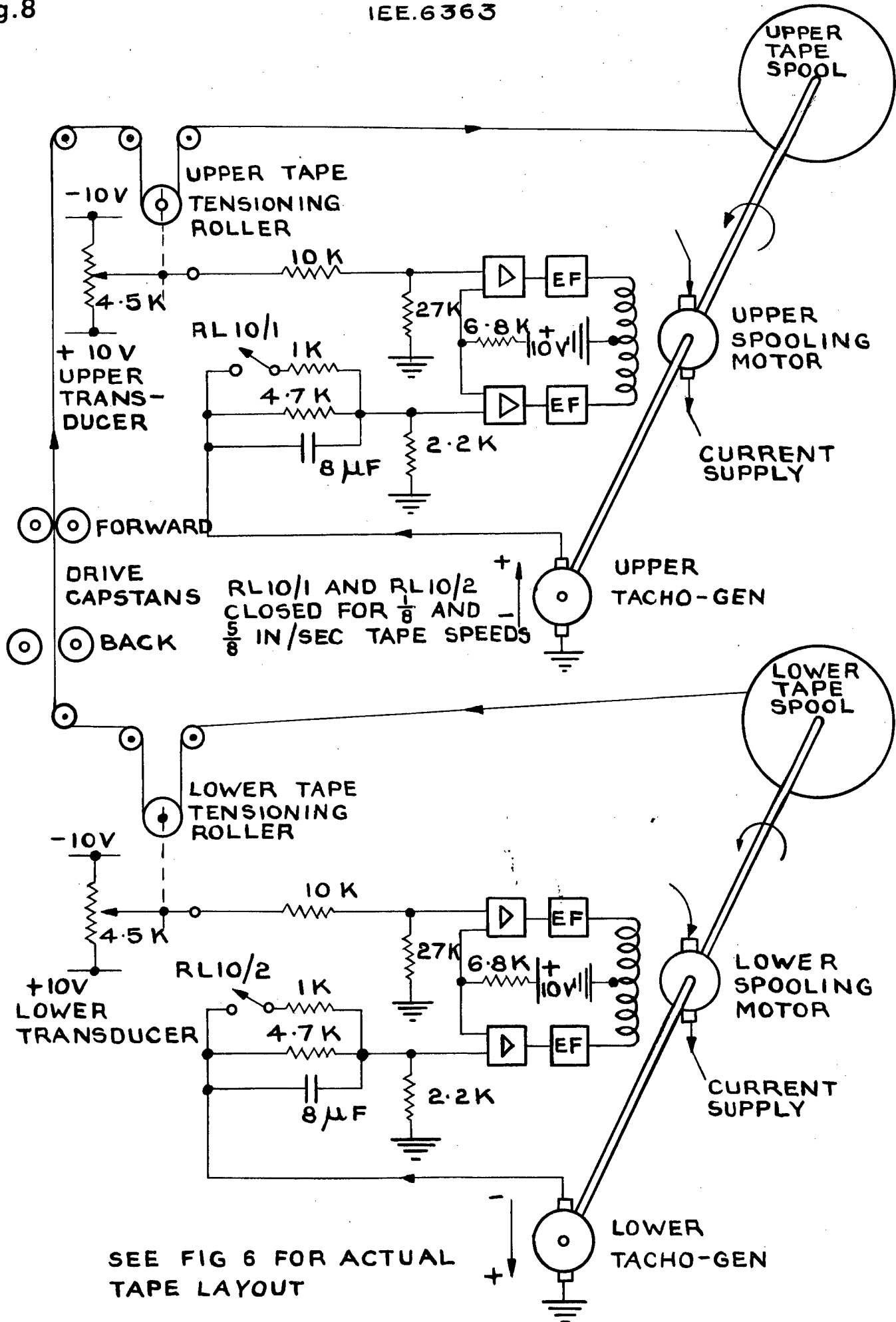
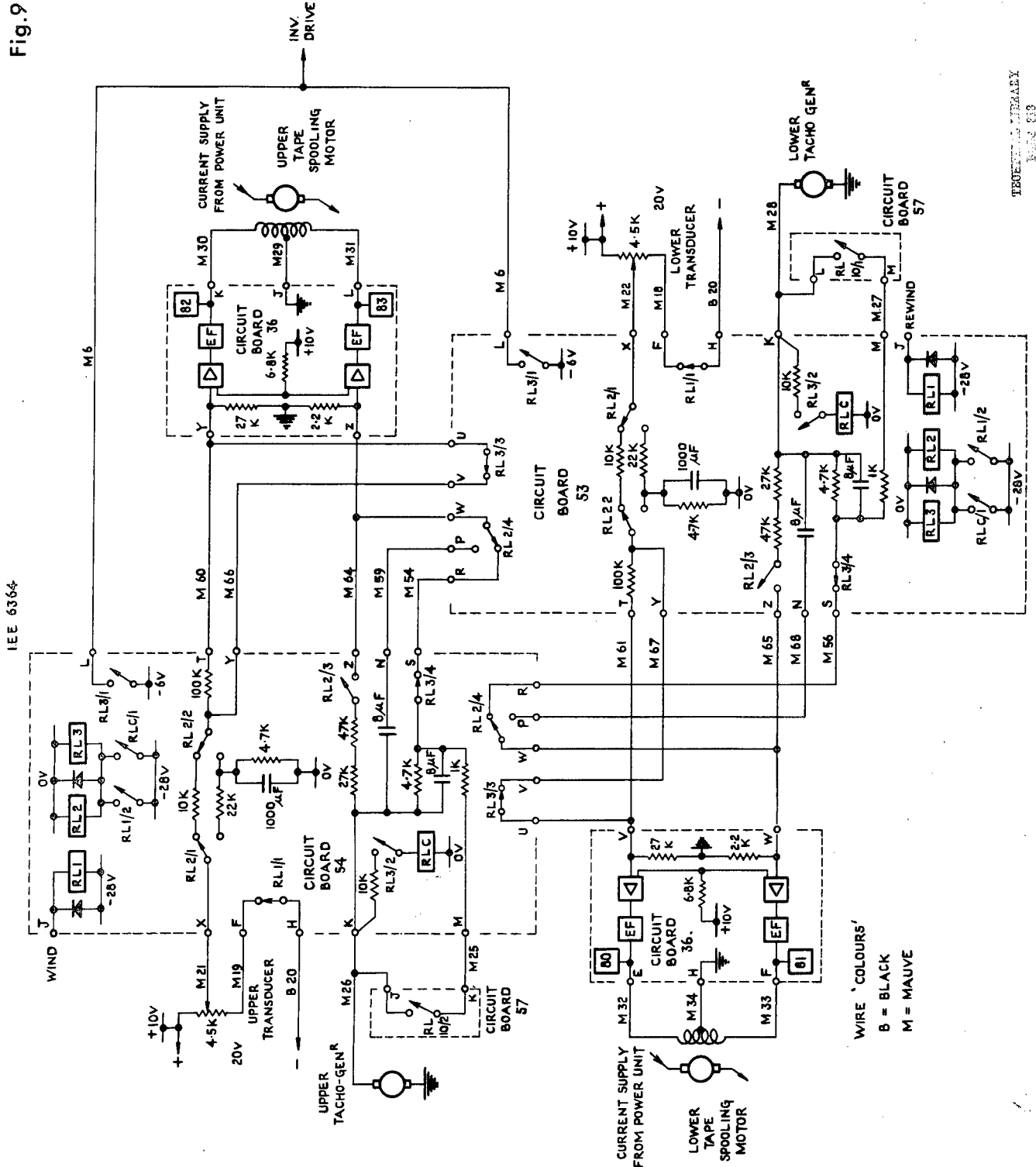

FIG. 8 TAPE SPOOLING IN THE DRIVE MODE

Fig.9



IEE 6364

FIG. 9 SPOOLING SERVO INTERCONNECTIONS

Fig.10

IEE 6365

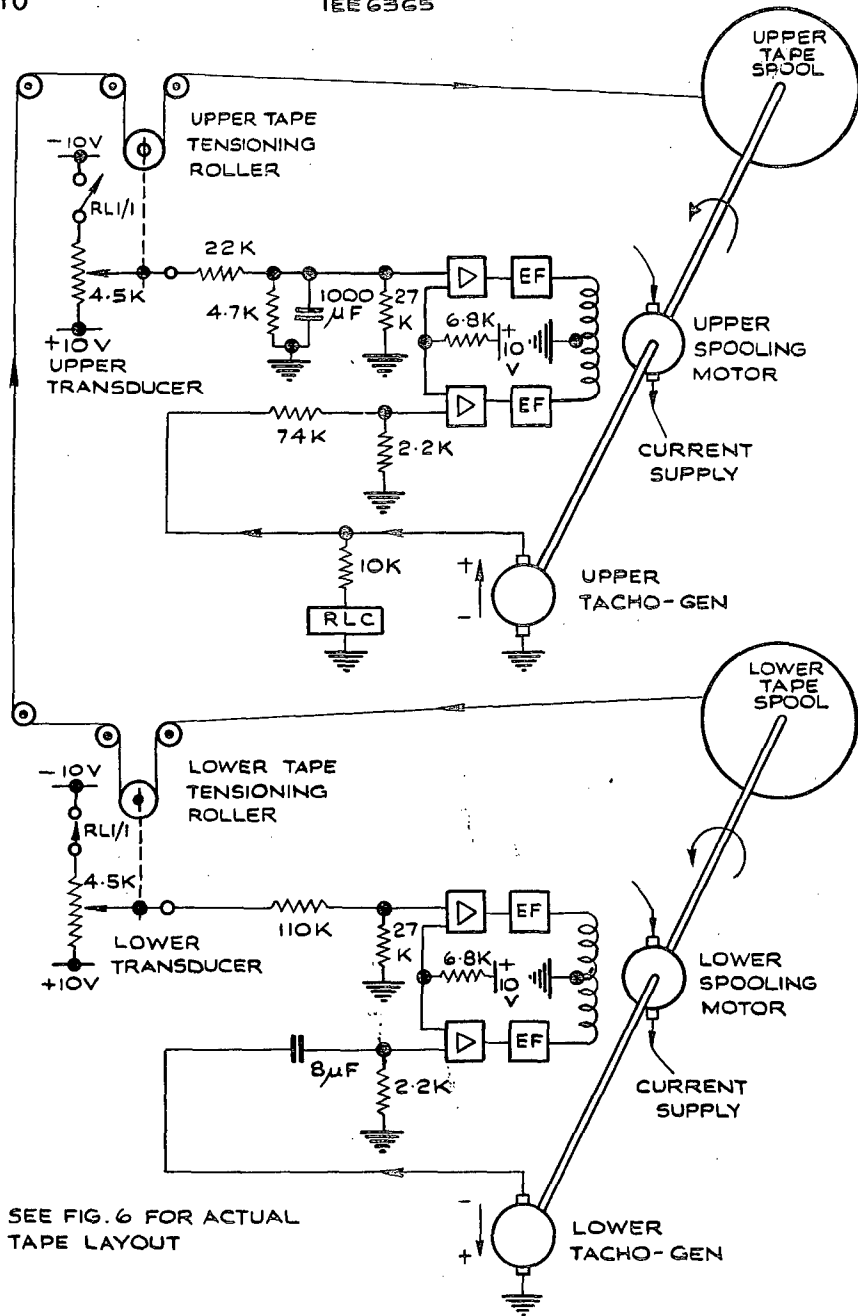

FIG.10 TAPE SPOOLING IN THE WIND (FORWARD) MODE

1EE6366

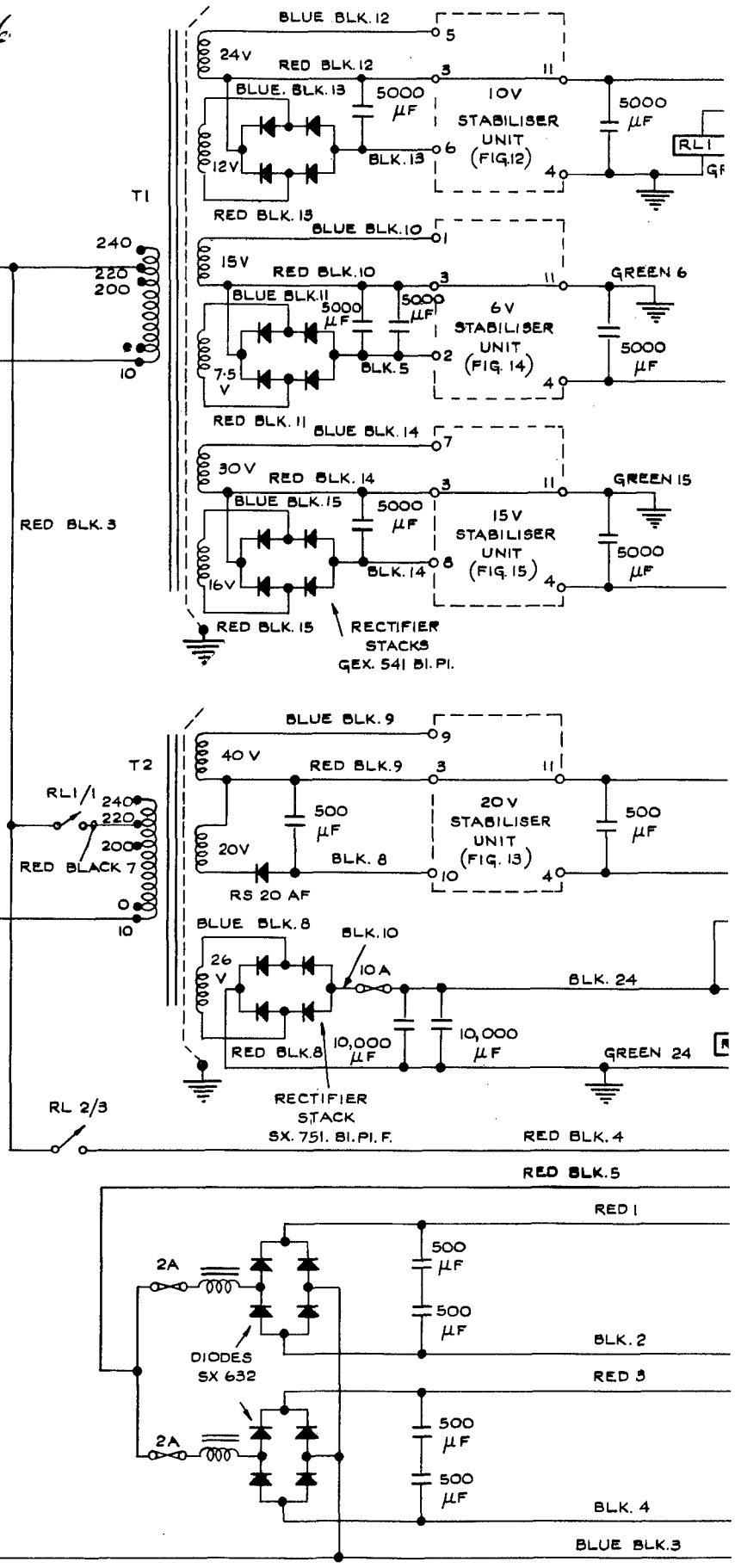
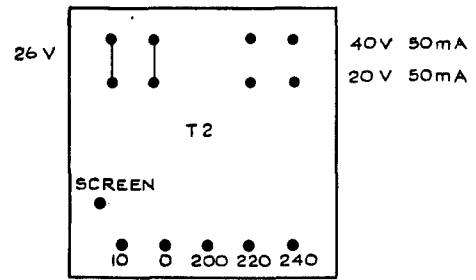
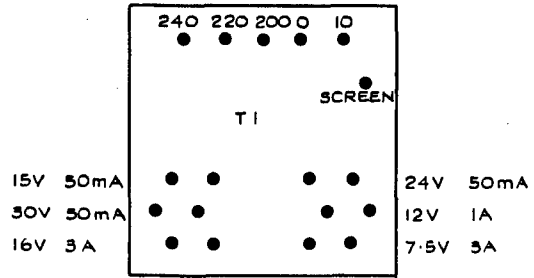
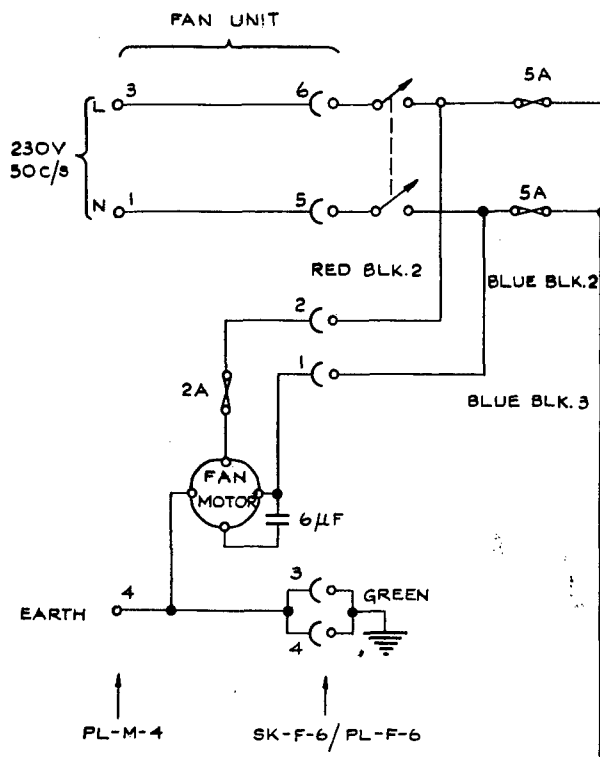
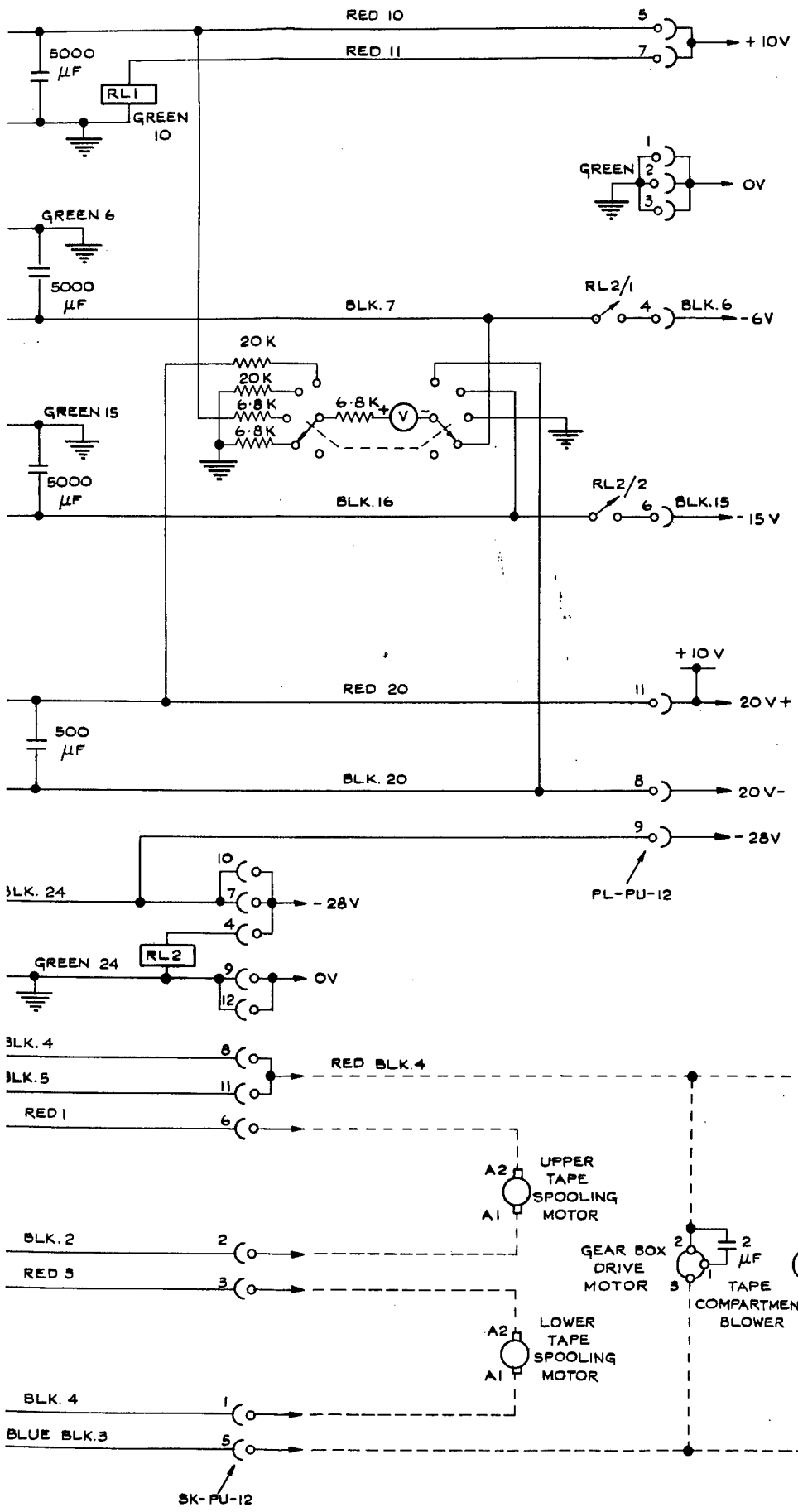

FIG.II POWER UNIT



UNIT

2

PLUG PL-D-12-SS		
PIN	FUNCTION	CABLE
1	READ/WRITE HEAD SOLENOID	MAUVE 1
2	LINKS TO SK-D-33-SS(PIN 19)	BROWN 4
3	CONTROL 'B'	ORANGE 35
4	RESET	BROWN 6
5	[13]	MAUVE 13
6	INV CONTROL 'B'	ORANGE 45
7		
8	MAINTENANCE F/F	ORANGE 36
9	[11]	MAUVE 11
10		
11	AUTO STOP	MAUVE 12
12		

SOCKET SK-D-33-SS		
PIN	FUNCTION	CABLE
1	UPPER TRANSDUCER OUTPUT	MAUVE 21
2	[13]	MAUVE 13
3	BACK BRAKE SOLENOID	MAUVE 7
4	LOWER TRANSDUCER OUTPUT	MAUVE 22
5	[10]	MAUVE 8
6	BACK DRIVE SOLENOID	MAUVE 9
7	+10V	+10V
8	DRIVE BACK BUTTON	MAUVE 10
9	[11]	MAUVE 11
10	+10V	+10V
11	SET INPUT AUTO STOP	MAUVE 39
12	RE-SET INPUT AUTO STOP	MAUVE 40
13	UPPER TACHO-GENERATOR	MAUVE 26
14	EARTH	EARTH
15	RL 4	MAUVE 14
16	RL6 RL7	MAUVE 15
17	EARTH	EARTH
18	RL 8	MAUVE 16
19	LINKED TO PL-D-12-SS (PIN 2)	BROWN 4
20	EARTH	EARTH
21		
22	LOWER TACHO-GENERATOR	MAUVE 28
23	EARTH	EARTH
24	C/C CONT. RELAY	BROWN 5
25	RL 1 (C.B.54) UPPER TRANS-DUCER	MAUVE 19
26	UPPER SPOOL MOTOR FIELD	MAUVE 31
27	UPPER SPOOL MOTOR FIELD	MAUVE 30
28	RL 1 (C.B.53) LOWER TRANS-DUCER	MAUVE 18
29	UPPER SPOOL MOTOR C/TAP	MAUVE 29
30	LOWER SPOOL MOTOR C/TAP	MAUVE 34
31	RESET	BROWN 6
32	LOWER SPOOL MOTOR FIELD	MAUVE 32
33	LOWER SPOOL MOTOR FIELD	MAUVE 33

CONNECTIONS

	CIRCUIT						
	59	58	57	36	54	53	
Z	—	MAUVE 40	MAUVE 37	MAUVE 64	MAUVE 64	MAUVE 65	MA 6
Y	—	—	MAUVE 38	MAUVE 60	MAUVE 66	MAUVE 67	—
X	—	MAUVE 39	MAUVE 44	—	MAUVE 21	MAUVE 22	—
W	—	—	MAUVE 45	MAUVE 65	MAUVE 65	MAUVE 64	MAI 5
V	—	—	MAUVE 20	MAUVE 61	MAUVE 67	MAUVE 66	MAI 1
U	—	—	—	—	MAUVE 61	MAUVE 60	MAI 2
T	—	—	MAUVE 35	—	MAUVE 60	MAUVE 61	[
S	—	—	BROWN 3	—	MAUVE 54	MAUVE 56]
R	—	—	BROWN 5	—	MAUVE 56	MAUVE 54	—
P	—	—	—	—	MAUVE 68	MAUVE 59	—
N	—	—	BROWN 1	—	MAUVE 59	MAUVE 68	—
M	—	—	MAUVE 27	—	MAUVE 25	MAUVE 27	—
L	—	—	MAUVE 28	MAUVE 31	MAUVE 6	MAUVE 6	—
K	—	MAUVE 12	MAUVE 25	MAUVE 30	MAUVE 26	MAUVE 28	—
J	—	MAUVE 17	MAUVE 26	MAUVE 29	MAUVE 63	MAUVE 62	—
H	—	—	ORANGE 36	MAUVE 34	BLACK 20	BLACK 20	—
F	RED 5	—	MAUVE 46	MAUVE 33	MAUVE 19	MAUVE 18	—
E	←	BLACK 30	→	MAUVE 32	←	→	—
D	←						RE IC
C	←						EAR
B	←						BLAI 6
A	←	BLACK 15	→	MAUVE 38	←	→	—

FIG. 25 - WIRING

CTIONS VIEWED FROM REAR

CIRCUIT BOARD NUMBER									
53			56						
MAUVE 65	MAUVE 63	MAUVE 62	MAUVE 1	MAUVE 5	MAUVE 4	MAUVE 9	MAUVE 7	MAUVE 1	Z
MAUVE 67	—	—	MAUVE 7	—	MAUVE 52	MAUVE 55	MAUVE 53	—	Y
MAUVE 22	—	—	MAUVE 9	—	—	—	—	—	X
MAUVE 64	MAUVE 57	MAUVE 51	MAUVE 4	MAUVE 3	MAUVE 2	—	—	—	W
MAUVE 66	MAUVE 17	MAUVE 17	MAUVE 5	—	MAUVE 8	—	—	—	V
MAUVE 60	MAUVE 20	MAUVE 20	MAUVE 15	—	ORANGE 45	—	—	—	U
MAUVE 61	⌋	⌋	MAUVE 6	—	⌋	—	—	—	T
MAUVE 56	⌋	⌋	MAUVE 48	MAUVE 52	⌋	—	MAUVE 55	—	S
MAUVE 54	—	—	MAUVE 49	MAUVE 55	—	MAUVE 52	MAUVE 52	—	R
MAUVE 59	—	—	MAUVE 42	MAUVE 53	—	MAUVE 11	MAUVE 10	MAUVE 12	P
MAUVE 68	—	—	MAUVE 14	MAUVE 6	MAUVE 6	MAUVE 6	MAUVE 6	MAUVE 6	N
MAUVE 27	—	—	MAUVE 13	—	—	ORANGE 35	ORANGE 35	—	M
MAUVE 6	—	—	MAUVE 16	—	—	—	—	—	L
MAUVE 28	—	—	MAUVE 51	—	—	—	—	—	K
MAUVE 62	—	—	MAUVE 57	—	—	—	—	—	J
BLACK 20	—	—	MAUVE 47	—	—	—	—	—	H
MAUVE 18	—	—	MAUVE 58	—	—	—	—	—	F
				BLACK 30					E
	RED 10								D
	EARTH								C
	BLACK 6								B
				BLACK 15					A

SOCKET SK-D-18-PS		
PIN	FUNCTION	CABLE
1	MOD. OSC OUTPUT	YELLOW 5
2	READ AMP BIAS	MAUVE 23
3	+10V	RED 10
4	-28V	BLACK 30
5	MOD. OSC. OUTPUT	YELLOW 7
6	EARTH	EARTH
7	C/C	MAUVE 36
8	CONT	MAUVE 37
9	-6V	BLACK 6
10	READ	MAUVE 20
11	WRITE	MAUVE 35
12	-15V	BLACK 15
13	HIGH Z	BROWN 8
14	LOW Z	BROWN 9
15	START P.B.	BROWN 7
16		
17		
18	+5V	RED 5

SOCKET SK-D-33-PS		
PIN	FUNCTION	CABLE
1	READ/WRITE HEAD SOLENOID	MAUVE 1
2	F.D. T.M.	MAUVE 2
3	F.B. T.M.	MAUVE 3
4	F.D. T.M.	MAUVE 4
5	F.B. T.M.	MAUVE 5
6		
7	SPEED CHANGE SOLENOID	BROWN 1
8	-28V TO ERASE OSCILLATOR	BROWN 3
9	READ LAMP	MAUVE 44
10	WRITE LAMP	MAUVE 45
11	FAIL LAMP	MAUVE 46
12	DOOR SWITCH (CLOSED)	MAUVE 47
13	UPPER LIMIT SWITCH	MAUVE 48
14	LOWER LIMIT SWITCH	MAUVE 49
15	DOOR SWITCH (OPEN)	MAUVE 42
16	20V SUPPLY -ve	BLACK 20
17		
18		
19	-28V	BLACK 30
20	-28V EARTH WIRE +ve	GREEN 24
21	EARTH	EARTH
22	-6V	BLACK 6
23	-15V	BLACK 15
24	HIGH Z	BROWN 8
25	LOW Z	BROWN 9
26	START P.B.	BROWN 7
27	READ AMP BIAS	MAUVE 23
28		
29	+5V	RED 5
30	20V SUPPLY +ve	RED 20
31	+10V	RED 10
32	MOD. OSC. OUTPUT	YELLOW 5
33	MOD. OSC. OUTPUT	YELLOW 7

WIRING DIAGRAM - BOX 'D'

2

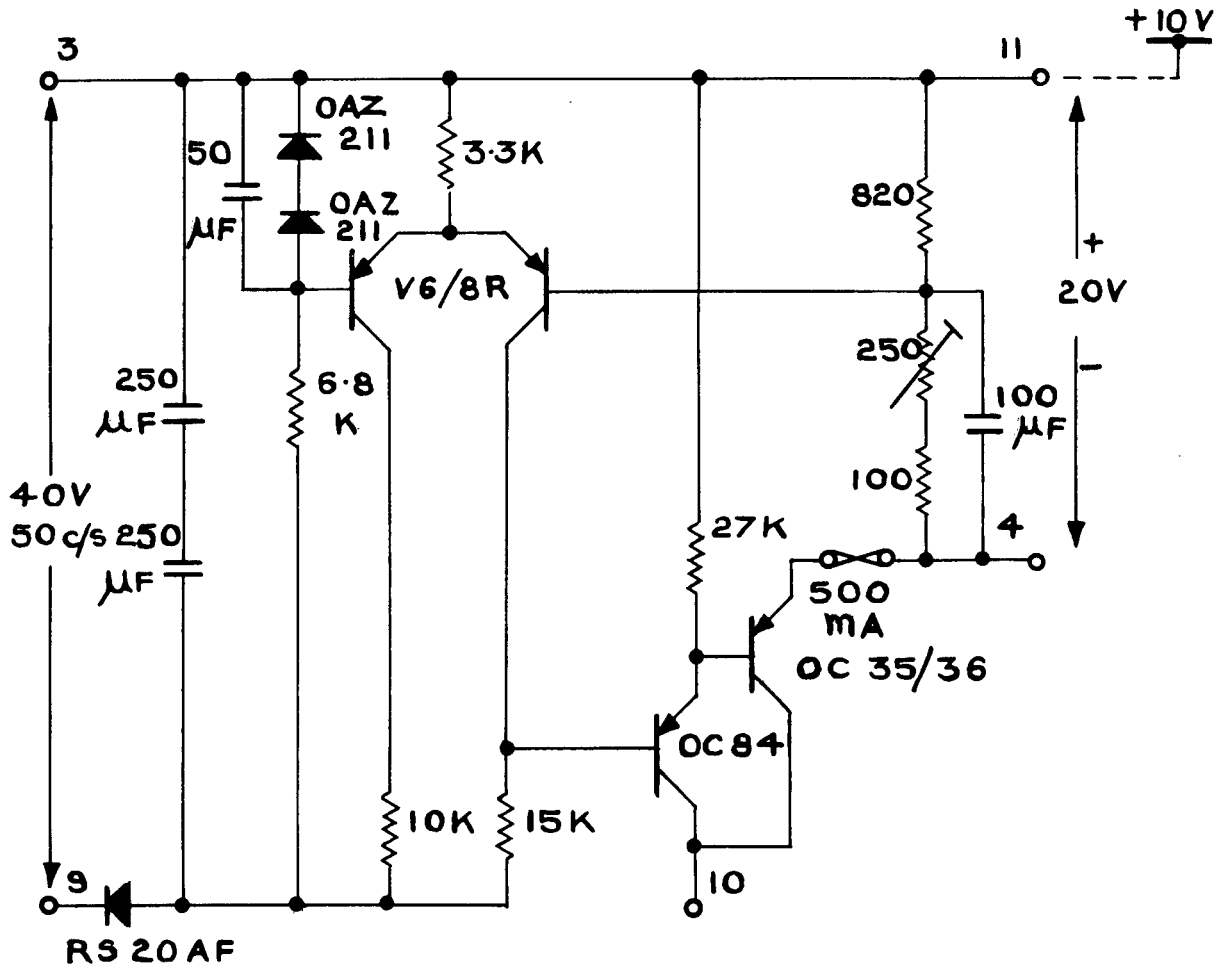

FIG. 13 20V STABILISER UNIT

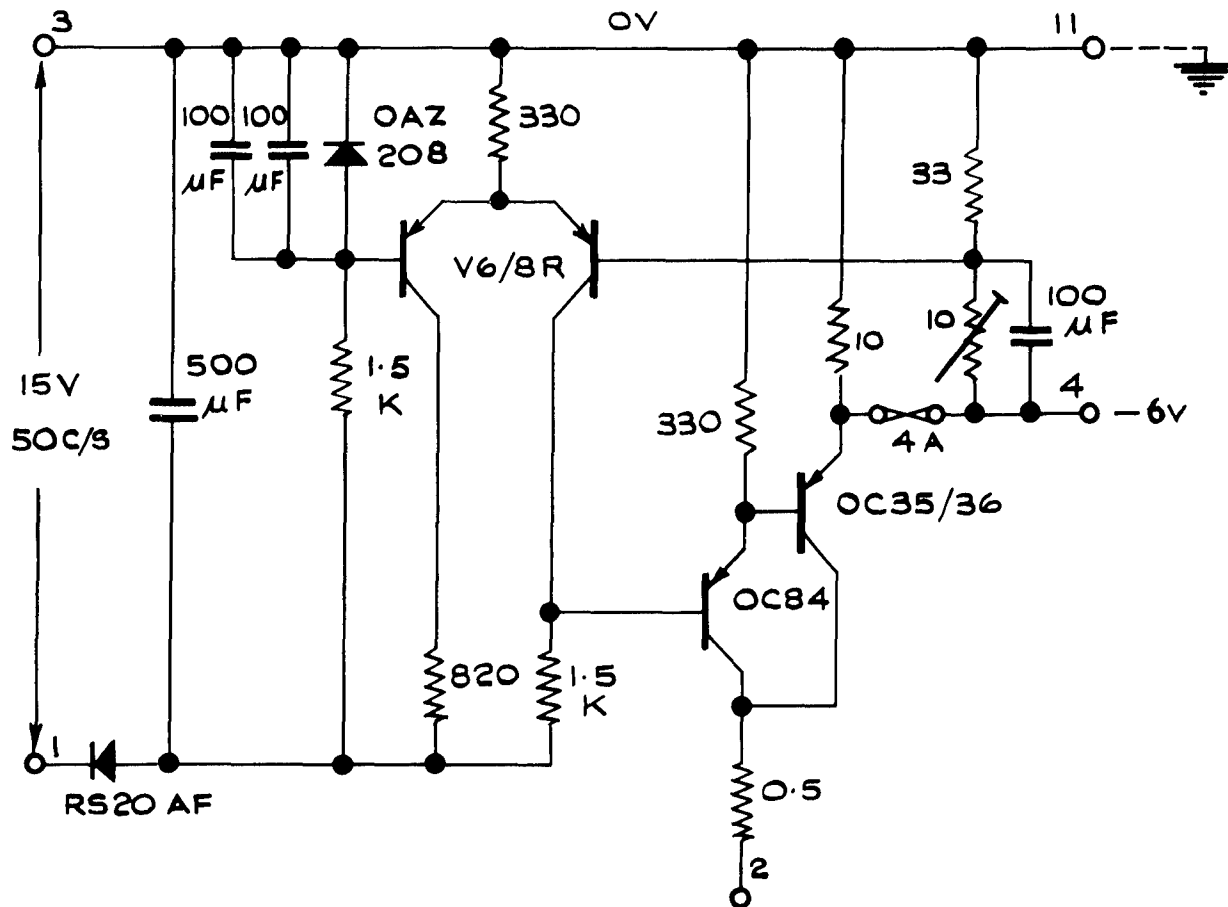

FIG.14 - 6 V STABILISER UNIT

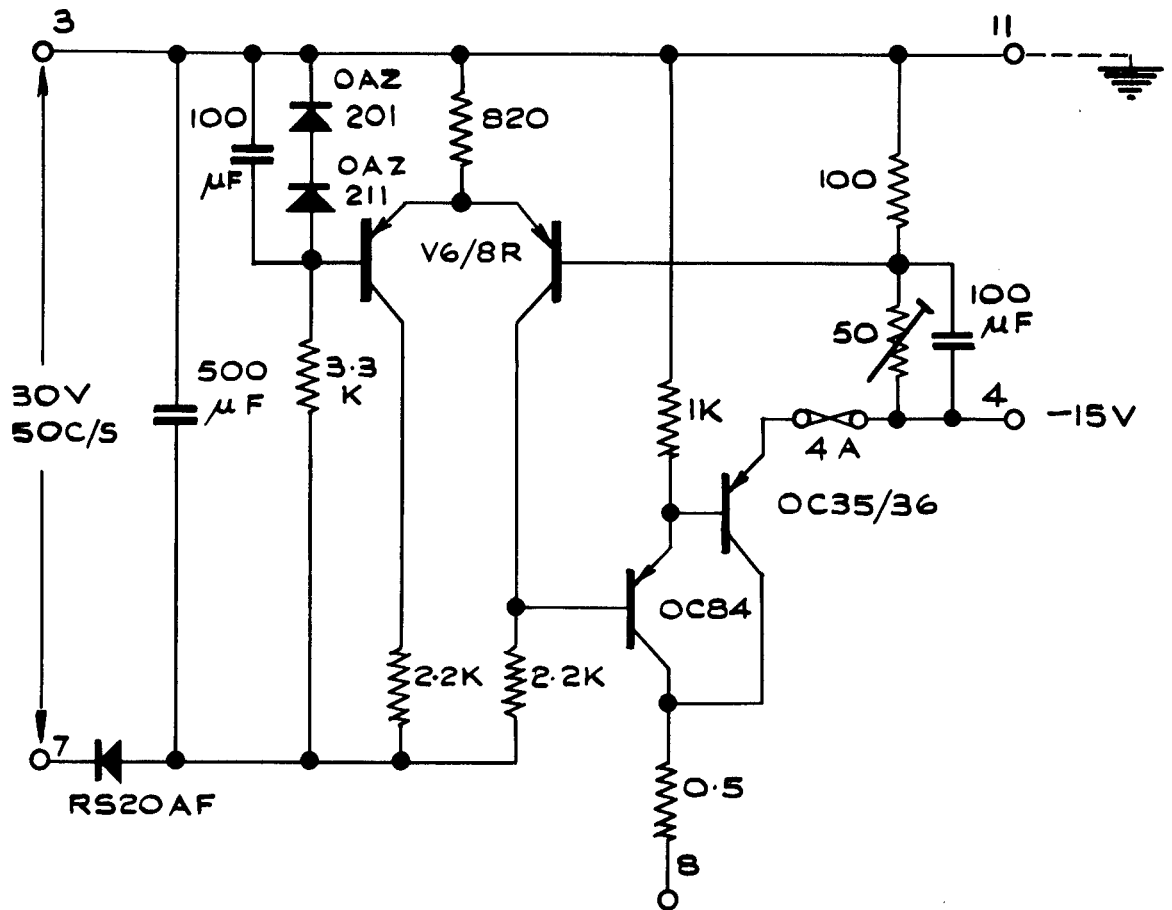

FIG.15 -15V STABILISER UNIT

Fig.16

1EE. 6371

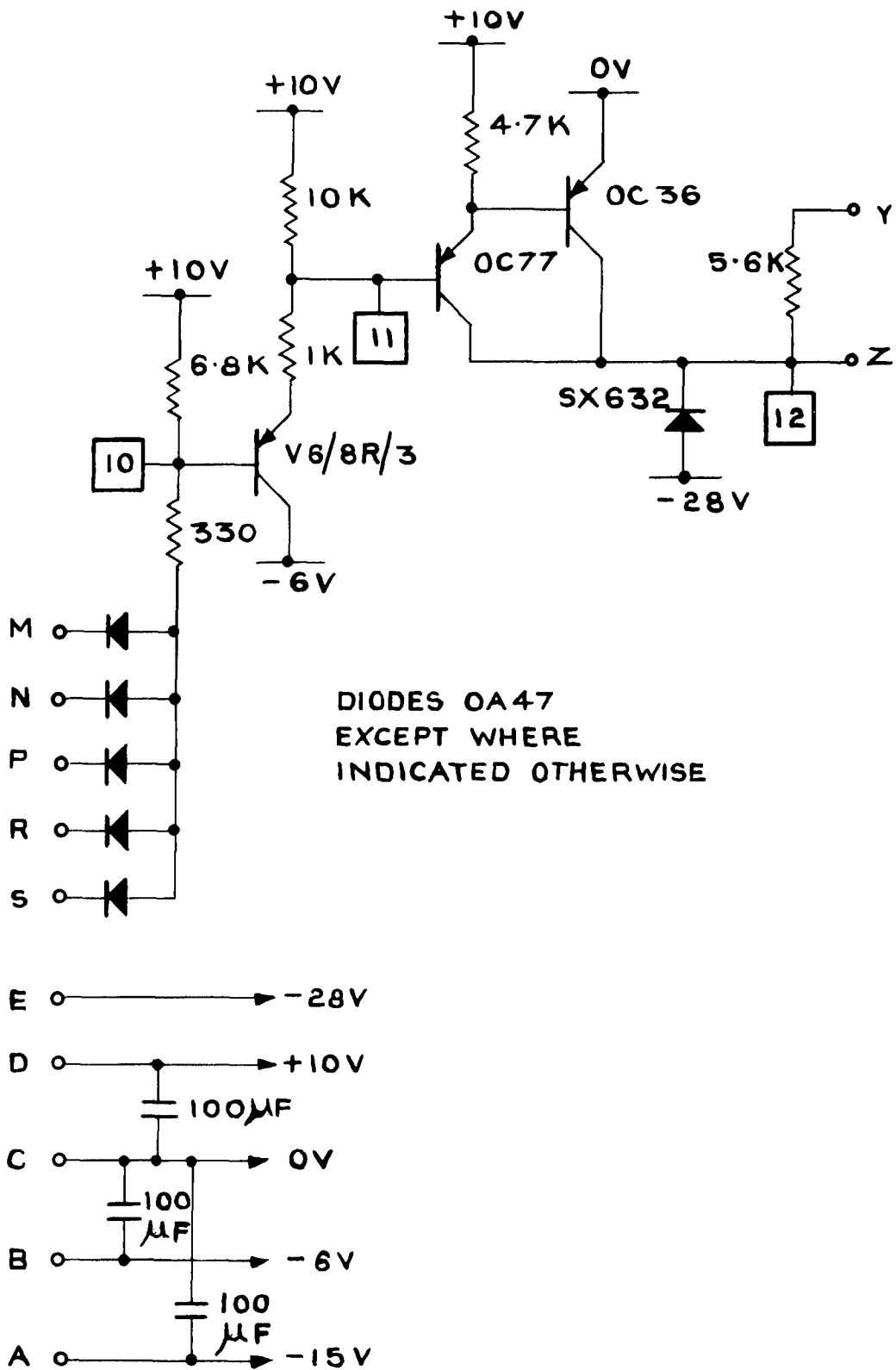

FIG. 16 CIRCUIT BOARD I-7A. (BACK BRAKE, BACK DRIVE AND READ/WRITE HEAD CONTROL)

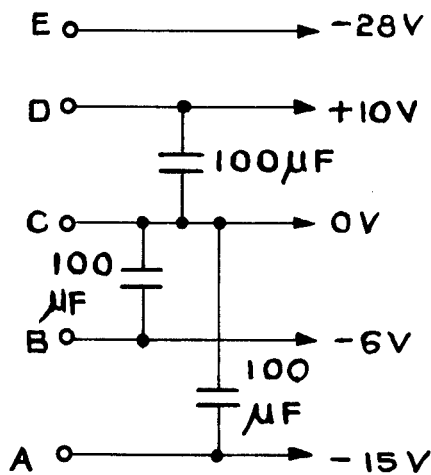
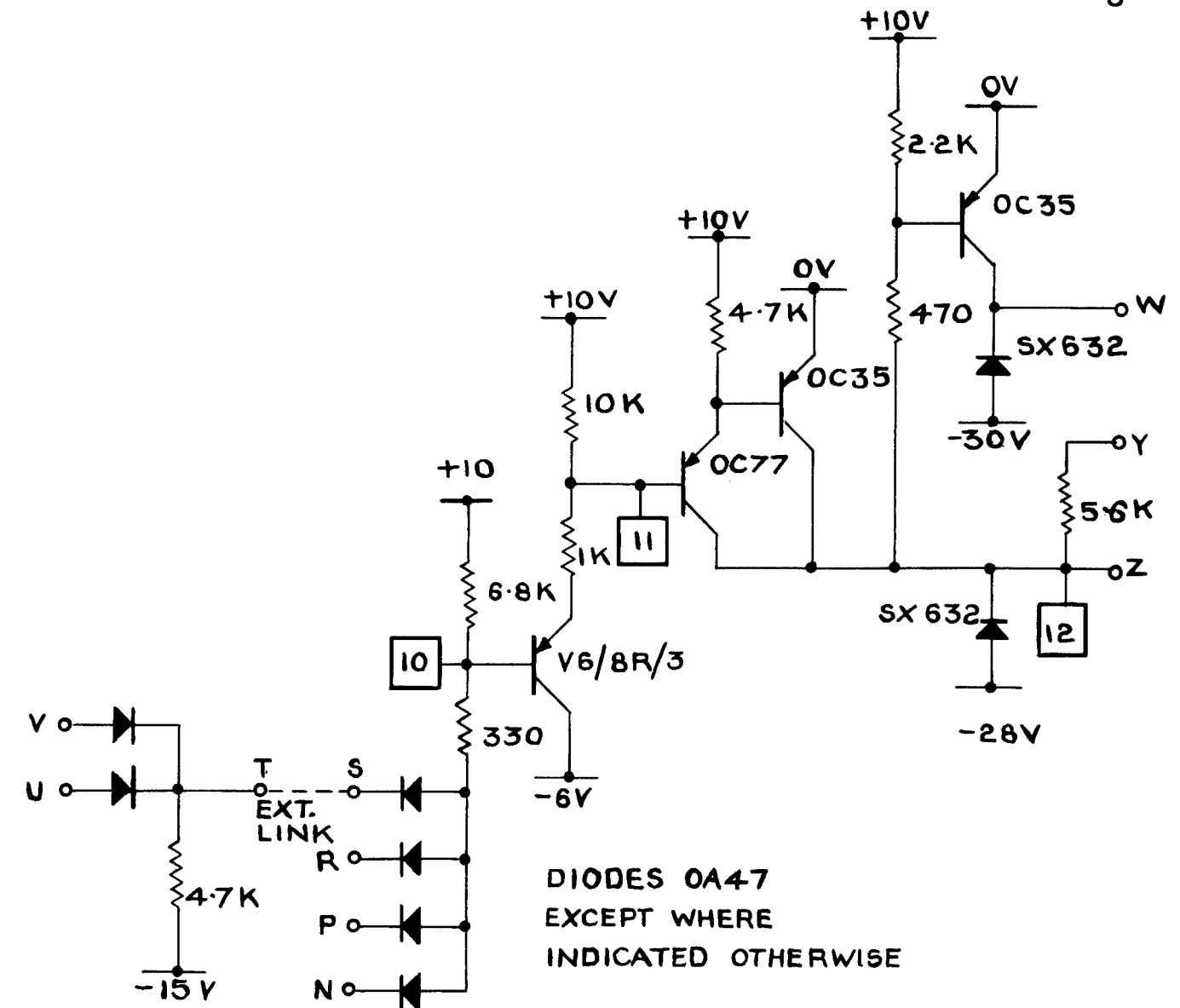

FIG. 17 CIRCUIT BOARD I-7B. (FORWARD DRIVE AND FORWARD BRAKE CONTROL)

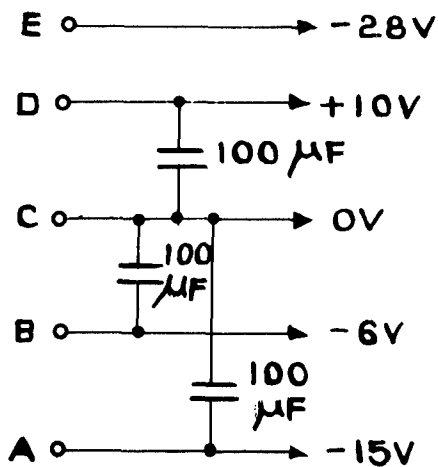
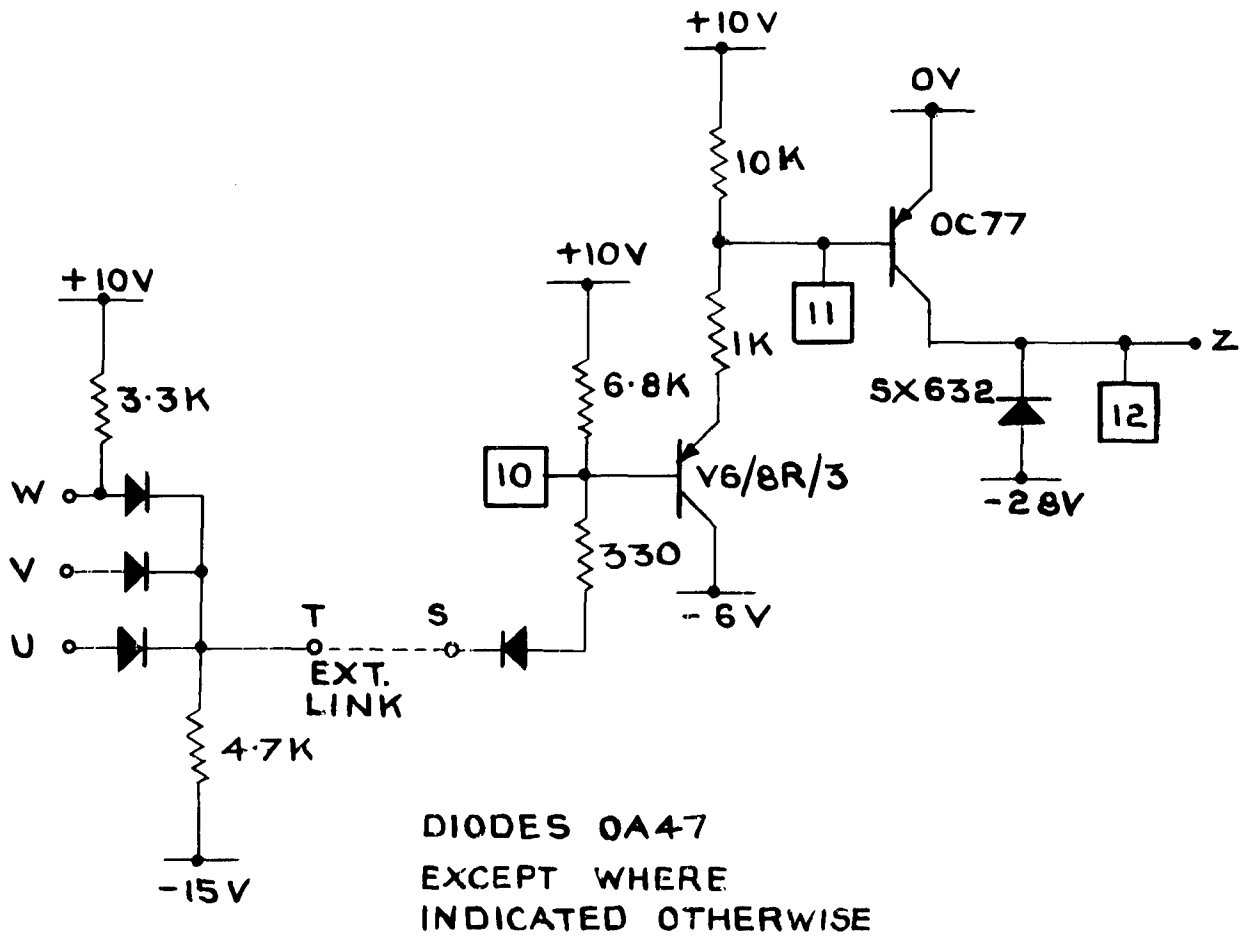
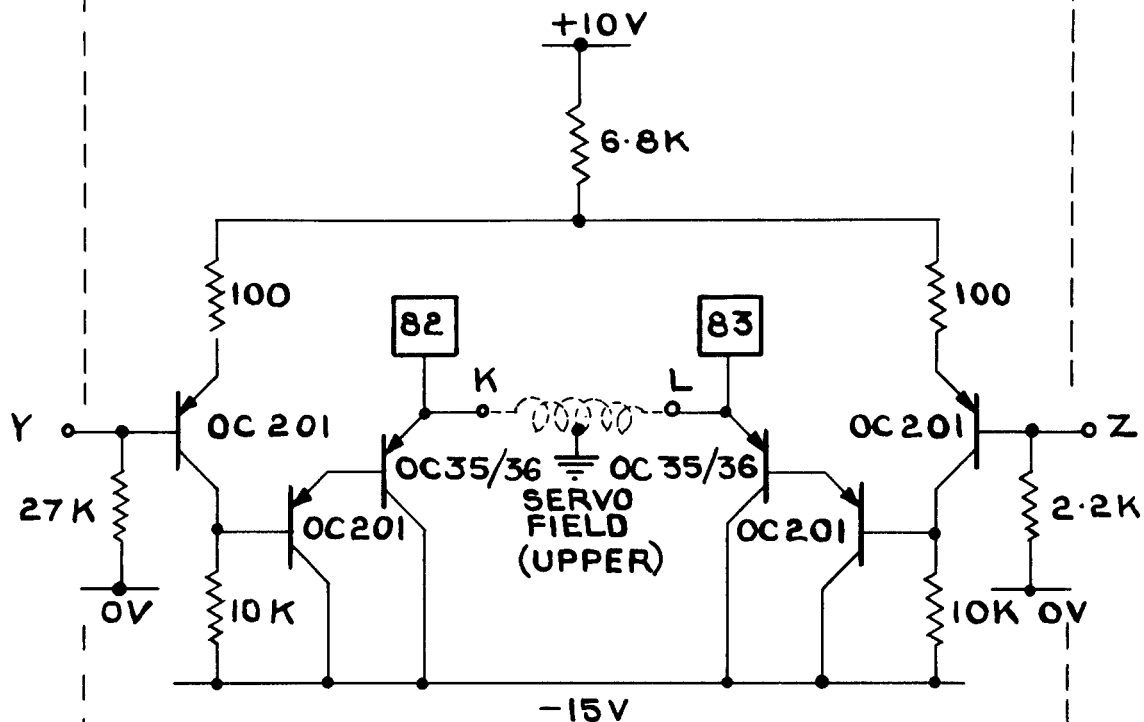

FIG. 18 CIRCUIT BOARD I-7C
(WIND AND REWIND CONTROL)



CIRCUIT AS SHOWN ABOVE.

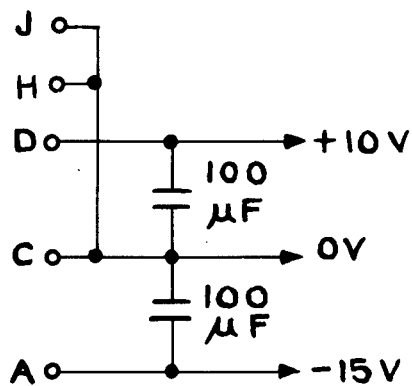
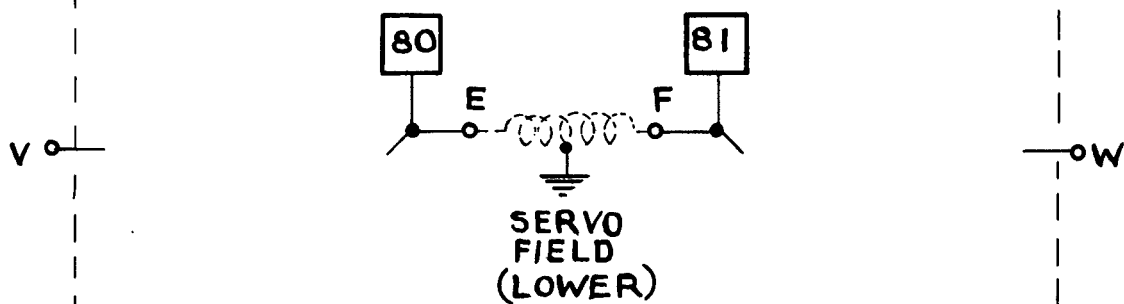

FIG. 19 CIRCUIT BOARD 36 (SERVO AMPLIFIERS)

Fig.20

IEE 6375

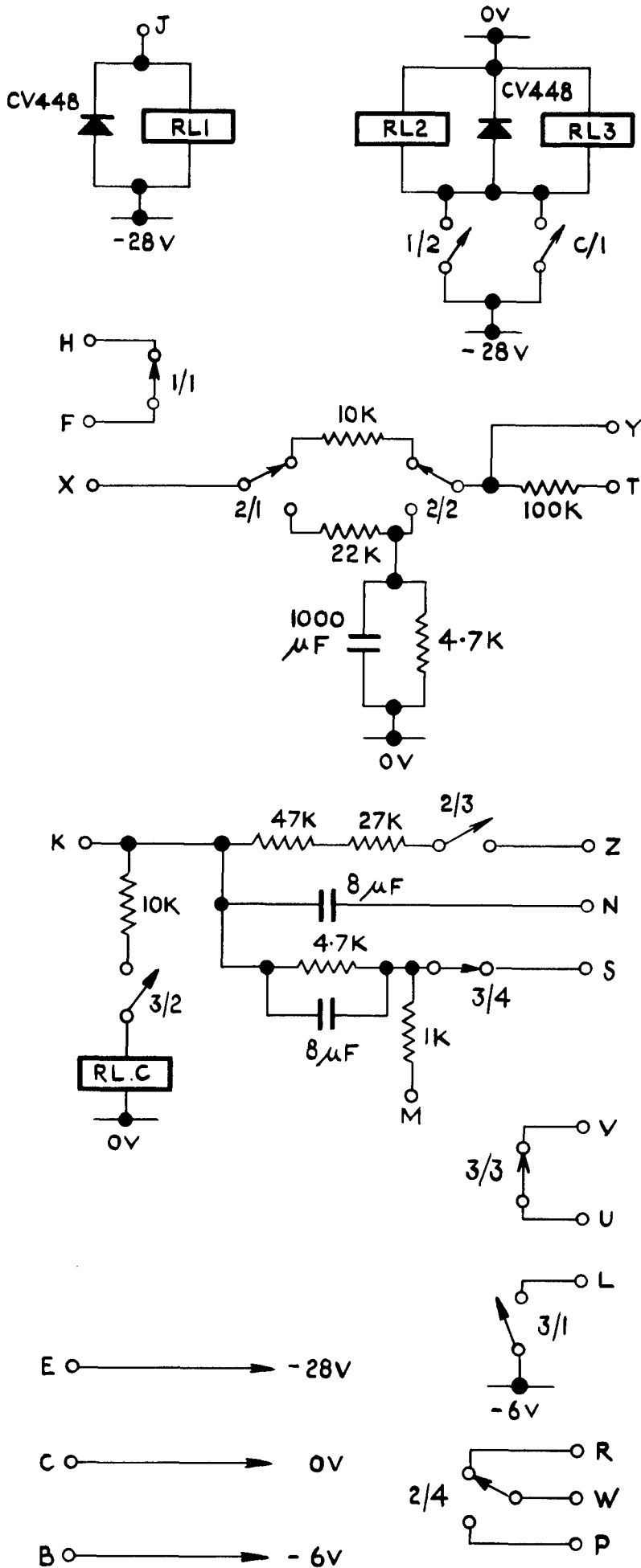
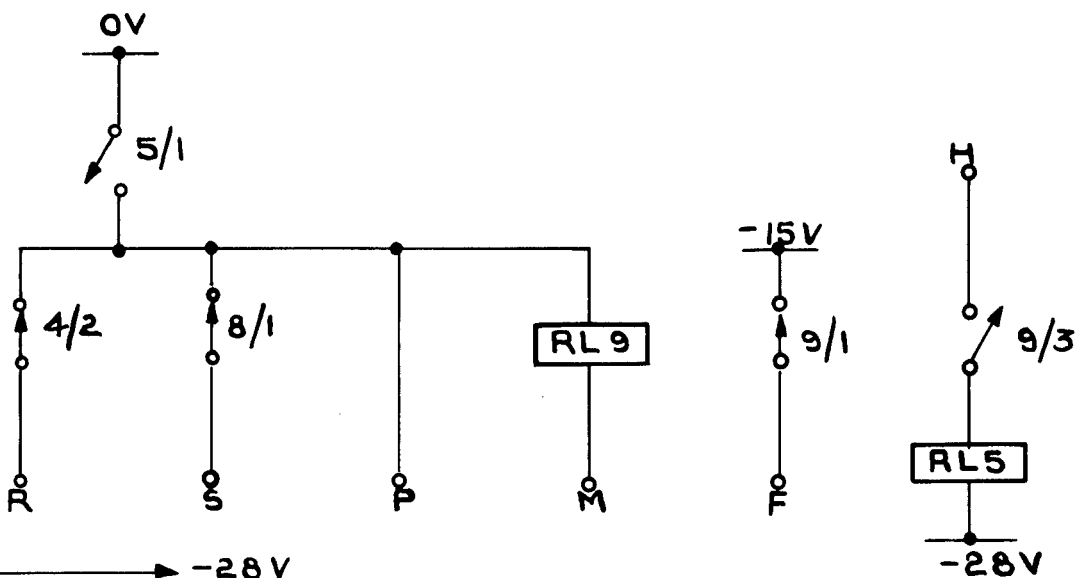
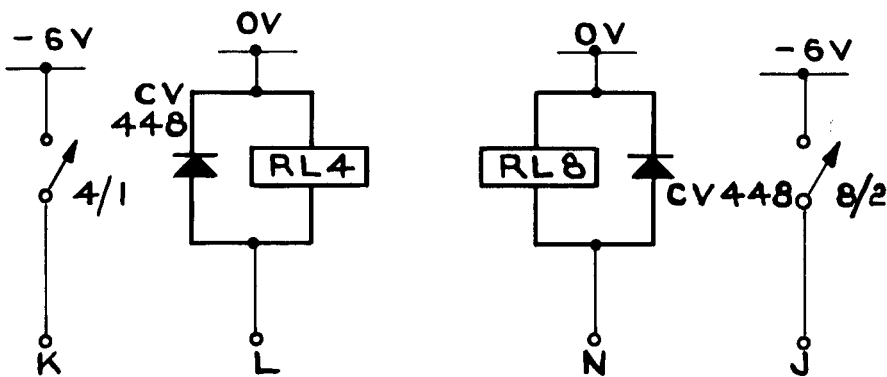
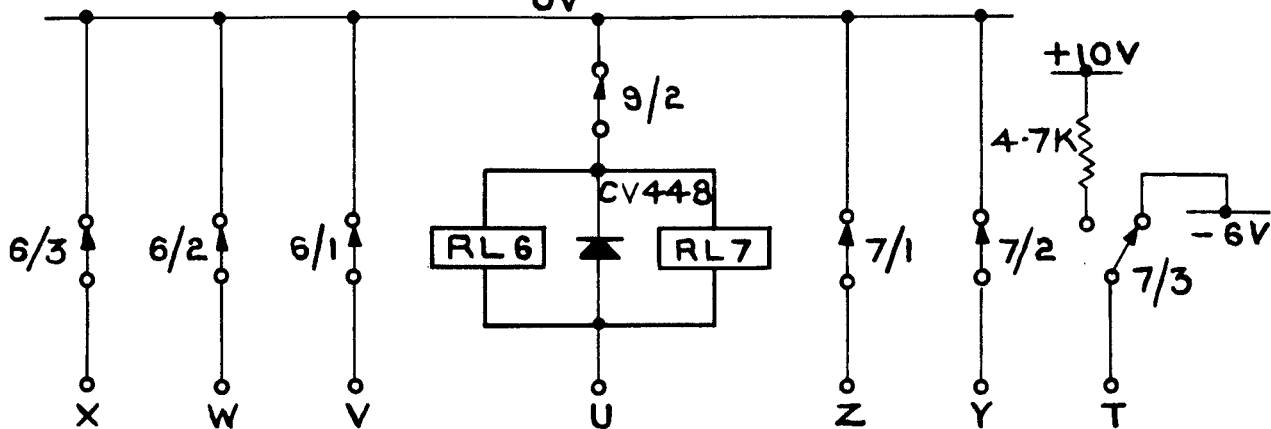

FIG. 20 CIRCUIT BOARDS 53-54 (SERVO RELAYS)



E → -28V

D → +10V

C → 0V

B → -6V

A → -15V

FIG. 21 CIRCUIT BOARD 56 (PROTECTION RELAYS)

Fig.22

IEE. 6377

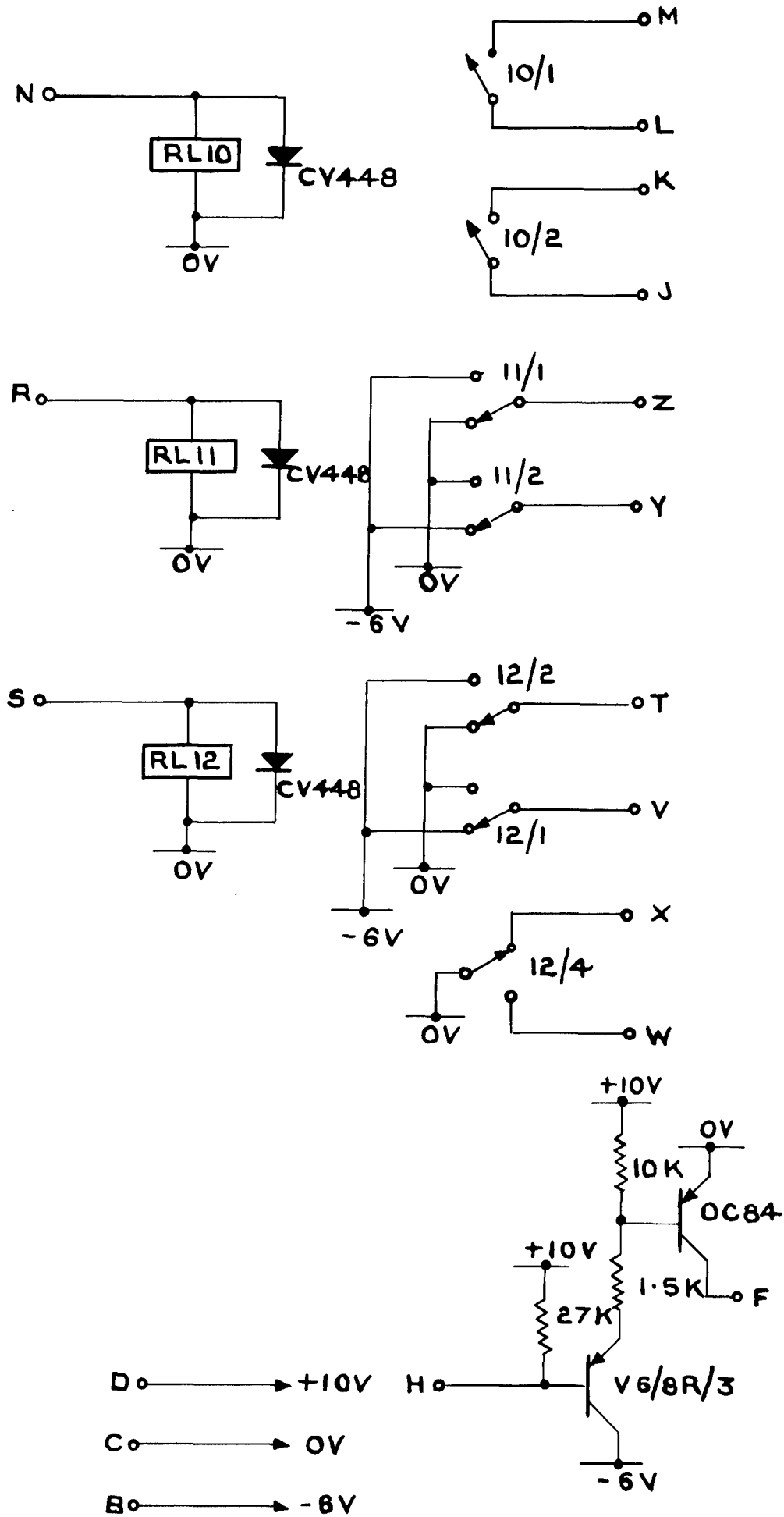
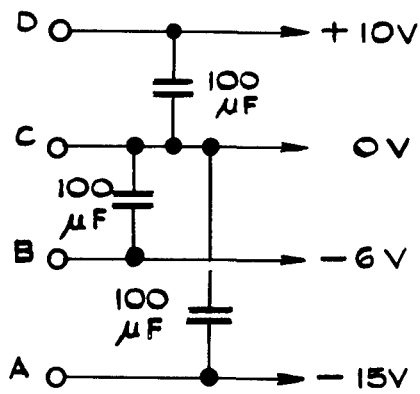
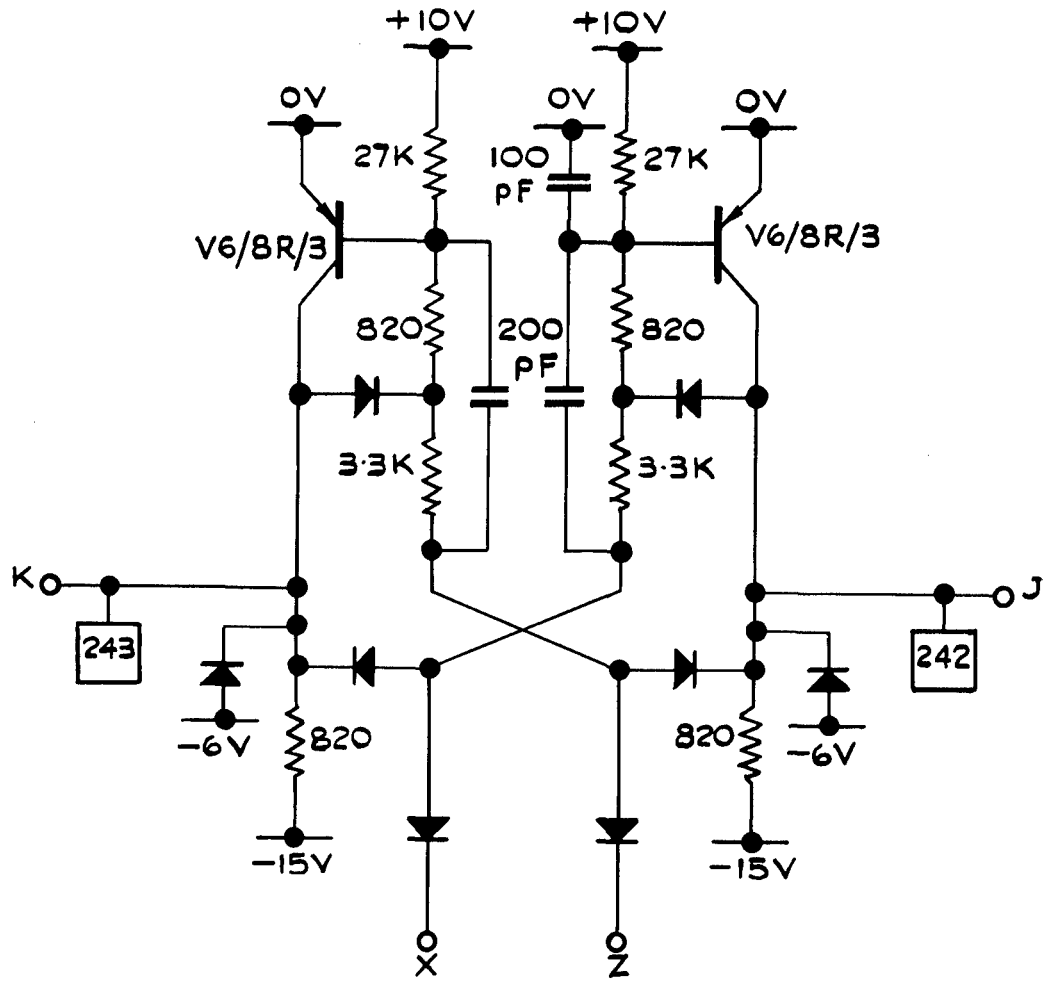

FIG. 22 CIRCUIT BOARD 57 (FUNCTION RELAYS)



DIODES OA47

FIG. 23 CIRCUIT BOARD 58 (AUTO-STOP)

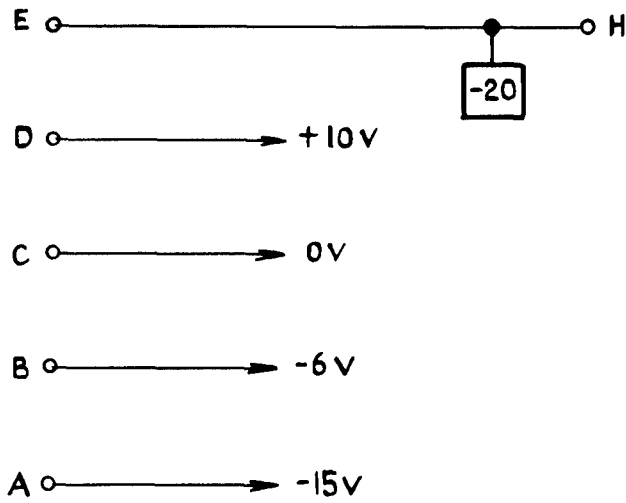
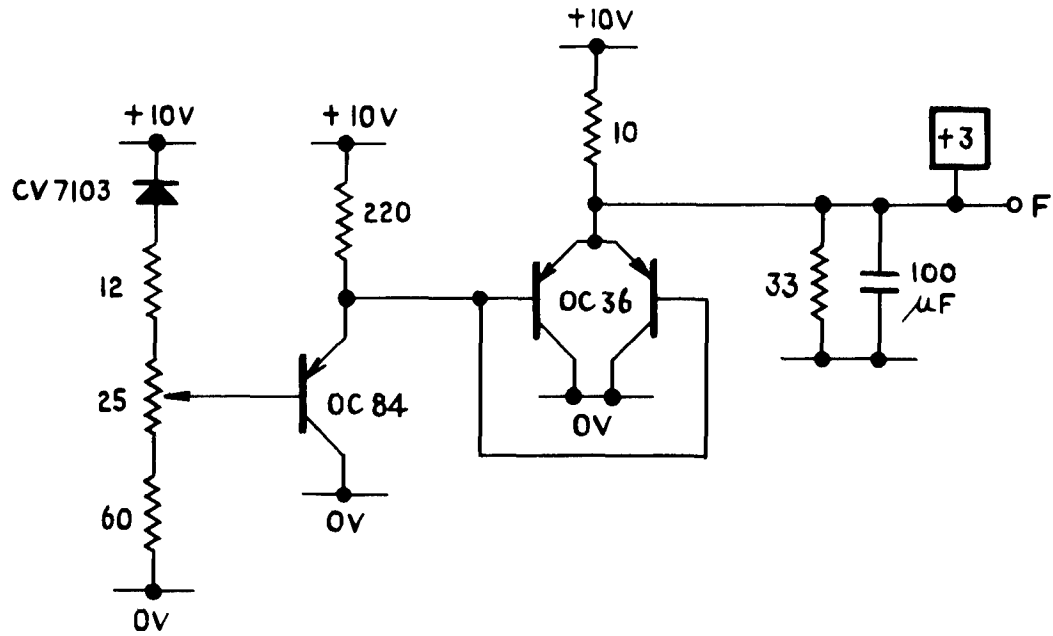

FIG. 24 CIRCUIT BOARD 59 (+3V POWER SUPPLY)

Sanderson, K.
Thane, P. D. M.

681.14 :
621.374.32 :
681.177.5

DIGITAL MAGNETIC TAPE UNITS FOR THE MERCURY AND DEUCE COMPUTERS
Part 2 - Control circuits

Royal Aircraft Establishment Technical Report 64054 November 1964

This part describes the function and format selection circuits, the circuits controlling tape drive and tape spooling, and the power supplies.

Sanderson, K.
Thane, P. D. M.

681.14 :
621.374.32 :
681.177.5

DIGITAL MAGNETIC TAPE UNITS FOR THE MERCURY AND DEUCE COMPUTERS
Part 2 - Control circuits

Royal Aircraft Establishment Technical Report 64054 November 1964

This part describes the function and format selection circuits, the circuits controlling tape drive and tape spooling, and the power supplies.

Sanderson, K.
Thane, P. D. M.

681.14 :
621.374.32 :
681.177.5

DIGITAL MAGNETIC TAPE UNITS FOR THE MERCURY AND DEUCE COMPUTERS
Part 2 - Control circuits

Royal Aircraft Establishment Technical Report 64054 November 1964

This part describes the function and format selection circuits, the circuits controlling tape drive and tape spooling, and the power supplies.