

UNCLASSIFIED

AD NUMBER

AD467227

CLASSIFICATION CHANGES

TO: UNCLASSIFIED

FROM: SECRET

LIMITATION CHANGES

TO:  
Approved for public release; distribution is unlimited.

FROM:  
Distribution authorized to DoD only; Administrative/Operational Use; APR 1953. Other requests shall be referred to the Defense Nuclear Agency, Washington, DC. Pre-dates formal DoD distribution statements. Treat as DoD only. Restricted Data.

AUTHORITY

DNA lt dtd 10 Aug 1984 and DSWA/OPSSI ltr dtd 11 Jun 1997  
DNA ltr dt 10 Aug 1984 and DSWA/OPSSI ltr dtd 11 Jun 1997

THIS PAGE IS UNCLASSIFIED

AD 467227

AUTHORITY:

DNA 1tr, 10 Aug 84



~~SECRET~~

WT-615

Copy No. 204 A

047330

UNCLASSIFIED

Operation

IVY

PACIFIC PROVING GROUNDS

TECHNICAL LIBRARY  
of the  
ARMED FORCES  
SPECIAL WEAPONS PROJECT  
4 NOV 1953

AD No. 467227

REF. FILE COPY

UNCLASSIFIED

November 1952 Classification (Cancelled) (Changed to  
By Authority of *Ch. Security Documents Dept 2/2/57*  
By *[Signature]* Date *MAR 22 1957*

Project 5.4a

NATURE, INTENSITY, AND DISTRIBUTION  
OF FALL-OUT FROM MIKE SHOT

QUALIFIED REQUESTERS MAY OBTAIN COPIES OF THIS REPORT FROM DDD



UNCLASSIFIED

This document contains restricted data as defined in the Atomic Energy Act of 1946. Its transmittal or the disclosure of its contents in any manner to an unauthorized person is prohibited.

AUG 6 1965

JOINT TASK FORCE 132

FISIA B

"This document contains information affecting the national defense of the United States within the meaning of the Espionage Laws, Title 18, U.S.C. Sections 793 and 794. The transmission or the revelation of its contents in any manner to an unauthorized person is prohibited by law."

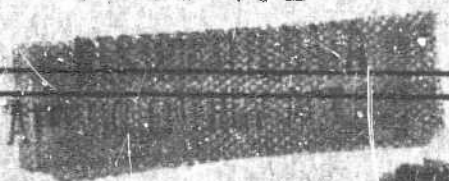

NOTICE: When government or other drawings, specifications or other data are used for any purpose other than in connection with a definitely related government procurement operation, the U. S. Government thereby incurs no responsibility, nor any obligation whatsoever; and the fact that the Government may have formulated, furnished, or in any way supplied the said drawings, specifications, or other data is not to be regarded by implication or otherwise as in any manner licensing the holder or any other person or corporation, or conveying any rights or permission to manufacture, use or sell any patented invention that may in any way be related thereto.

# DISCLAIMER NOTICE

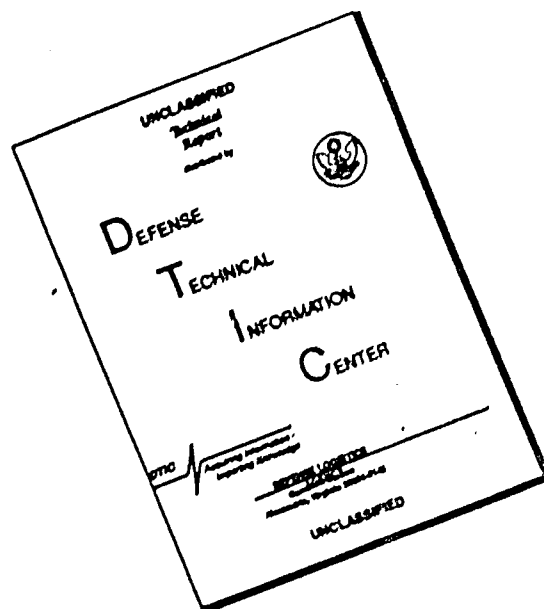

THIS DOCUMENT IS BEST QUALITY AVAILABLE. THE COPY FURNISHED TO DTIC CONTAINED A SIGNIFICANT NUMBER OF PAGES WHICH DO NOT REPRODUCE LEGIBLY.



WT-615

This document consists of 84 pages  
No. 204 of 265 copies, Series A

~~Report to the Scientific Director~~

NATURE, INTENSITY, AND DISTRIBUTION  
OF FALL-OUT FROM MIKE SHOT,

By

W. B. Heidt, Jr., ~~FOIA~~  
E. A. Schuert  
W. W. Perkins  
R. L. Stetson

UNCLASSIFIED

*3. 12. 1953 Operation  
Mike Shot*

QUALIFIED

NAVY COPY DOC.

*L-1*

*D*  
~~Naval Radiological Defense Lab~~  
San Francisco, California  
April 1953



... fined ...  
transmission of the message of its contents in  
any manner to an unauthorized person is pro-  
hibited.

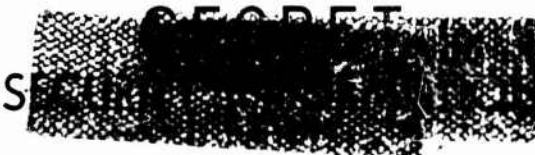



UNCLASSIFIED

## ABSTRACT

The physical and chemical properties of the particulate matter deposited following Mike shot, Operation Ivy, together with its distribution in time and area, were investigated. Total fall-out and differential fall-out collectors were installed on islands, anchored lagoon floats, and free-floating sea stations about the detonation point. All collected samples were analyzed at the U. S. Naval Radiological Defense Laboratory.

All the samples of primary fall-out collected were in a cross-wind direction from the detonation point; secondary fall-out samples were collected to distances of 600 miles from this point. Radiation levels as high as 800 r/hr at 2 hr were found 3 miles from the detonation point. No positive evidence of the occurrence of a base surge was found.

The primary fall-out was a dry or semidry particulate of compounds of calcium with entrapped fission products. This particulate underwent a chemical change when in a sea-water environment, causing it to become very firmly attached to any surface it touched. Particles were found ranging in diameter from less than  $10 \mu$  to more than  $5000 \mu$ . There was no indication of size fractionation of the particles with distance and only meager evidence of size fractionation with time. The quantity of primary fall-out varied from more than 20 g/sq ft at 4 miles cross wind to 0 g/sq ft at 15 miles from the shot point. The time of arrival along the cross-wind direction was completely independent of the distance from the shot point.

The secondary fall-out originating in the stratosphere was less than  $25 \mu$  in diameter and arrived 2 to 5 days after shot time. None of the stations where secondary fall-out was collected reported a gamma dose rate greater than 10 mr/hr.

UNCLASSIFIED

# UNCLASSIFIED

## CONTENTS

	Page
ABSTRACT . . . . .	3
CHAPTER 1 INTRODUCTION . . . . .	9
1.1 Previous Fall-out Studies . . . . .	9
1.1.1 At Operation Greenhouse . . . . .	9
1.1.2 At Operation Jangle . . . . .	9
1.2 Objectives . . . . .	10
CHAPTER 2 OPERATIONS . . . . .	
2.1 Land Stations . . . . .	11
2.2 Lagoon Stations . . . . .	14
2.3 Sea Stations . . . . .	14
2.3.1 Shipboard Stations . . . . .	14
2.3.2 Free-floating Stations . . . . .	15
2.3.3 Operational Success . . . . .	17
CHAPTER 3 INSTRUMENTS . . . . .	18
3.1 Design Criteria . . . . .	18
3.1.1 Collecting Requirements . . . . .	18
3.1.2 Mechanical and Electrical Restrictions . . . . .	18
3.1.3 Pressure and Thermal Effects Expected from the Bomb Burst . . . . .	18
3.1.4 Environmental Requirements . . . . .	19
3.2 Total Fall-out Collector . . . . .	19
3.3 Differential Fall-out Collector . . . . .	19
3.4 Incremental Liquid Fall-out Collectors . . . . .	19
3.5 Rain Gage . . . . .	19
3.6 Ion-exchange Columns . . . . .	25
3.7 Gum-paper Collector . . . . .	25
3.8 Air Sampler . . . . .	25
3.9 Design of Stations . . . . .	25
3.10 Evaluation of Instruments . . . . .	31
3.10.1 Rain Gage . . . . .	31
3.10.2 Incremental Collector . . . . .	31
3.10.3 Differential Fall-out Collector . . . . .	31
3.10.4 Trigger Mechanism . . . . .	31
3.10.5 Total Collector . . . . .	32
3.10.6 Ion-exchange Collector . . . . .	32
3.10.7 Gum-paper Collectors . . . . .	32
3.10.8 Résumé of the Operation of the Instruments . . . . .	32

~~SECRET~~  
**UNCLASSIFIED**

**CONTENTS (Continued)**

	Page
<b>CHAPTER 4 PRIMARY FALL-OUT</b>	<b>33</b>
4.1 Gamma Field	33
4.2 Physical and Chemical Nature of the Fall-out	35
4.2.1 Physical Description of Particulate	35
4.2.2 Chemical Composition of the Particulate	35
4.2.3 Leaching of Activity	39
4.2.4 Decay of Activity	41
4.3 Physical Distribution of Fall-out	41
4.4 Particulate-size Distribution, Radioactive	41
4.4.1 Particle-size Distribution as a Function of Time	41
4.4.2 Particle-size Distribution as a Function of Distance	41
4.5 Time of Arrival of Particulate	41
4.5.1 Arrival of Fall-out	47
4.5.2 Duration of Fall-out	47
4.5.3 Distribution of Activity with Time	47
<b>CHAPTER 5 SECONDARY FALL-OUT</b>	<b>48</b>
5.1 Distribution of Secondary Fall-out	48
5.2 Levels of Radioactivity	48
5.3 Period of Secondary Fall-out	48
5.4 Particle Size of Secondary Fall-out	48
<b>CHAPTER 6 METEOROLOGICAL CONSIDERATIONS AND FORECASTS OF FALL-OUT</b>	<b>51</b>
6.1 Theories of Fall-out Mechanism	51
6.2 Primary Fall-out	51
6.3 Secondary Fall-out	53
6.4 The Effect of Vertical Mixing	53
<b>CHAPTER 7 SUMMARY</b>	<b>54</b>
7.1 Conclusions	54
7.1.1 Primary Fall-out	54
7.1.2 Secondary Fall-out	55
7.2 Recommendations	55
<b>APPENDIX A EXPERIMENTAL PROCEDURE</b>	<b>57</b>
A.1 Analysis of the Total-collector Samples	57
A.2 Analysis of the Gum-paper Samples	57
A.3 Analysis of the Differential Fall-out Samples	57
A.4 Chemical Analysis of Fall-out Samples	58
A.5 Analysis of the Leached Activity	58
A.6 Radiochemical Analysis of Selected Samples	58
A.7 Ion-exchange-collector Analysis	58

6  
~~RESTRICTED DATA - SECRET - SECURITY INFORMATION~~  
**UNCLASSIFIED** **UNCLASSIFIED**

**UNCLASSIFIED**

**CONTENTS (Continued)**

	Page
APPENDIX B TABULATED DATA . . . . .	59
B.1 Total-collector and Rain-gage Data . . . . .	59
B.2 Secondary Fall-out Data . . . . .	59
B.3 Summary of Data Collected on the Free-floating Sea Stations . . . . .	59
APPENDIX C ELECTRONIC TRIGGER MECHANISM . . . . .	67
C.1 Purpose . . . . .	67
C.2 Operation . . . . .	67
C.3 General Comments . . . . .	69
APPENDIX D OPERATIONAL ORDERS AND PERSONNEL LOGISTICS . . . . .	70
D.1 Operation Order . . . . .	70
D.2 Personnel Logistics . . . . .	78
D.2.1 Design of Instruments and Equipment . . . . .	78
D.2.2 Laboratory Work on Samples . . . . .	78
D.2.3 On-site Personnel . . . . .	79
D.2.4 Fall-out Stations on Land . . . . .	79
D.2.5 Fall-out Stations on Ships . . . . .	79
D.2.6 Free-floating Sea Stations . . . . .	79

**ILLUSTRATIONS**

**CHAPTER 2 OPERATIONS**

2.1 Eniwetok Atoll Stations . . . . .	12
2.2 Outer Island Stations . . . . .	13
2.3 Free-floating Sea-station Array . . . . .	16

**CHAPTER 3 INSTRUMENTS**

3.1 Total Fall-out Collector . . . . .	20
3.2 Differential Fall-out Collector . . . . .	21
3.3 Light-actuated Trigger Mechanism . . . . .	22
3.4 Incremental Liquid Fall-out Collector . . . . .	23
3.5 Recording Rain Gage . . . . .	24
3.6 Ion-exchange-column Collector . . . . .	26
3.7 Gum-paper Collector Kit . . . . .	27
3.8 A Typical Land Station . . . . .	28
3.9 A Typical Lagoon Station . . . . .	29
3.10 Free-floating Sea Station . . . . .	30

**CHAPTER 4 PRIMARY FALL-OUT**

4.1 Fall-out Gamma Pattern at 2 Hr as Would Be Experienced on a Land Mass (r/hr) . . . . .	34
4.2 Particles Collected by a Differential Fall-out Collector . . . . .	36

7  
**UNCLASSIFIED**      **UNCLASSIFIED**  
RESTRICTED DATA - SECRET - SECURITY INFORMATION

**UNCLASSIFIED**

**ILLUSTRATIONS (Continued)**

	Page
4.3 Plan View of a Typical Fall-out Particle Deposited on Life-float Decking . . . . .	36
4.4 Inverted View of Typical Particles Removed from Life-float Decking . . . . .	37
4.5 Typical Life-float Section . . . . .	38
4.6 Particle Deposition on Life-float Decking . . . . .	38
4.7 Beta and Gamma Decay Curve from 15 to 90 Days After Shot . . . . .	42
4.8 Mass Distribution of Fall-out (g/sq ft) . . . . .	43
4.9 Variation of Cross-wind Fall-out with Distance from Ground Zero . . . . .	44
4.10 Size Distribution of Radioactive Particles as a Function of Time and Distance . . . . .	45
4.11 Periods of Primary Fall-out at Different Stations . . . . .	46
 <b>CHAPTER 5 SECONDARY FALL-OUT</b>	
5.1 Radioautograph of Secondary Fall-out Particles . . . . .	49
5.2 Periods of Secondary Fall-out at the Outer Island Stations . . . . .	50
 <b>CHAPTER 6 METEOROLOGICAL CONSIDERATIONS AND FORECASTS OF FALL-OUT</b>	
6.1 Predicted Area of Primary Fall-out . . . . .	52
 <b>APPENDIX C ELECTRONIC TRIGGER MECHANISM</b>	
C.1 Schematic Diagram of the Electronic Trigger Mechanism . . . . .	68

**TABLES**

<b>CHAPTER 3 INSTRUMENTS</b>	
3.1 Instrumentation at Land and Lagoon Stations at Eniwetok Atoll . . . . .	32
 <b>CHAPTER 4 PRIMARY FALL-OUT</b>	
4.1 Spectrographic Analysis of the Radioactive Particles Removed from the Life-float Decking . . . . .	39
4.2 X-ray-diffraction Analysis of Radioactive Particles Removed from the Differential Fall-out Collectors . . . . .	40
4.3 Size Distribution of Radioactive Fall-out Particles . . . . .	47
 <b>APPENDIX B TABULATED DATA</b>	
B.1 Weight and Activity of Solid Fraction of Collected Material . . . . .	60
B.2 Volume and Activity of Liquid Fraction of Collected Material . . . . .	61
B.3 Total Activity and Total Mass of Collected Material . . . . .	62
B.4 Secondary Fall-out Data, Gummed-paper Collectors . . . . .	63
B.5 Free-floating Sea Stations . . . . .	66

8

**UNCLASSIFIED**    **RESTRICTED DATA - SECRET**    **UNCLASSIFIED**    **SECURITY INFORMATION**

UNCLASSIFIED

## CHAPTER 1

### INTRODUCTION

The gamma-radiation hazard associated with radioactive debris from nuclear explosions constitutes an important capability of atomic weapons. The degree to which this capability can be exploited depends upon the magnitude of the militarily significant gamma-radiation fields produced and upon the ability to predict the location and extent of these fields. The phenomenon, commonly referred to as fall-out, varies with weapon yield and conditions of detonation. The present work proposes to extend the knowledge of such variations by investigating the fall-out material from Mike shot, Operation Ivy. The information derived will be useful for both offensive and defensive planning.

#### 1.1 PREVIOUS FALL-OUT STUDIES

Fall-out from surface and subsurface nuclear detonations has been documented at previous test programs. The phenomenon was first observed after the detonation of the Alamo-gordo device in 1945.<sup>1</sup> Since that time it has become well established that the gamma hazard resulting from fall-out must be seriously considered as a problem of military significance for all types of detonations except the air burst.\* Fall-out was first fully documented at Operation Jangle, but limited data were obtained at Operations Crossroads and Greenhouse.

##### 1.1.1 At Operation Greenhouse

The fall-out study conducted at Operation Greenhouse revealed significant residual contamination from the Dog and Easy tower shots. This investigation was the first comprehensive study of fall-out forecasting.<sup>2</sup> These forecasting techniques, together with the work of J. O. Hirschfelder,<sup>3</sup> are the basis for the theories presented in the discussion of the fall-out at Operation Ivy.

##### 1.1.2 At Operation Jangle

The surface shot at Operation Jangle more nearly represented a miniature Mike shot than any previous detonation. Fall-out studies were made at this operation, and complete data were obtained to a distance of several miles from ground zero.<sup>4</sup> The results were used in planning for Operation Ivy, and certain data to be found herein were extrapolated from information gained from the fall-out studies of Operation Jangle.

\*An air burst is defined for the purposes of this report as an explosion detonated at an elevation of such height that the resulting fireball at no time touches the surface of the earth.

9  
UNCLASSIFIED SECRET UNCLASSIFIED

~~SECRET~~  
UNCLASSIFIED

## 1.2 OBJECTIVES

The gathering of fall-out data from Mike shot was a logical extension of previous fall-out documentation. The nature of Mike shot, Operation Ivy, made the study of fall-out extremely important. The yield from this shot was expected to exceed by many times that from any previous detonation, and consequently the cloud and associated debris were expected to rise to much greater heights. The additional fact that the shot was to be a surface explosion indicated the possibility of serious fall-out over large areas.

The present work (Project 5.4a) was designed to accomplish the following specific objectives:\*

1. To measure the amount, distribution, and particle size of radioactive fall-out following Mike shot at Operation Ivy.
2. To determine at a limited number of close stations the rate of arrival of inert liquid or solid materials and associated radioactive materials.
3. To determine the particle-size fractionation of the radioactive fall-out with time and distance.
4. To analyze the base surge, if formed, for activity and to correlate this information with the fall-out data.
5. To correlate the fall-out pattern obtained with that predicted from a knowledge of the meteorological conditions and atomic cloud behavior.
6. To calculate from the intensities of radiation from fall-out the radiation field levels which would have been observed if the fall-out had occurred over extended land areas

## REFERENCES

1. Los Alamos Scientific Laboratory, "The Effects of Atomic Weapons," pp. 270-275, U. S. Government Printing Office, Washington, 1950.
2. Charles E. Adams, Fall-out Phenomenology, Greenhouse Report, Annex 6.4, WT-4, August 1951.
3. Los Alamos Scientific Laboratory, "The Effects of Atomic Weapons," Appendix F, U. S. Government Printing Office, Washington, 1950.
4. I. G. Poppoff, Fall-out Particle Studies, Jangle Project 2.5a-2 Report, WT-395; also in Particle Studies, WT-371.

\*Full attainment of the objectives of this project was not possible because of operational restrictions imposed at a late date. See Appendix D, Tab A (revised) to Appendix I to Annex V.

10  
~~RESTRICTED DATA - SECRET - SECURITY INFORMATION~~  
UNCLASSIFIED UNCLASSIFIED

UNCLASSIFIED

## CHAPTER 2

### OPERATIONS

Preliminary estimates of the extent and intensity of fall-out expected from Mike shot varied by as much as an order of magnitude. Since no one estimate could be assigned a high degree of confidence, plans were based on the maximum prediction.

Providing instrumentation for extensive areas, many of which were over open water, presented a difficult logistic problem. Since it was not practical to locate stations at great distances over 360°, a forecast was made of the most probable wind pattern expected at shot time, and this was used as a basis for laying out the collecting station array. Atoll island stations, anchored lagoon stations, distant island stations, and an array of free-floating sea stations oriented in the quadrant having the highest probability of receiving fall-out were used.

An examination of the geographical location of Eniwetok Atoll, and in particular Elugelab Island, on which the shot occurred, shows that the number of land masses available for fall-out studies was extremely limited (Fig. 2.1). Beyond Eniwetok Atoll, the following were the only logistically acceptable locations for these studies: Guam, about 1000 miles to the west; Wake, about 600 miles to the northeast; Bikini, about 190 miles to the east; Kwajalein and Majuro, to the southeast about 300 and 600 miles, respectively; Kusaie, about 400 miles to the south; and Ujelang and Ponape, to the southwest about 150 and 300 miles.

#### 2.1 LAND STATIONS

Stations were established on the following islands of Eniwetok Atoll: Bogallua (Alice), Engebi (Janet), Yeiri (Nancy), Piiraai (Wilma), Runit (Yvonne), Aniyaanii (Bruce), Parry (Elmer), and Eniwetok (Fred).

Stations were also located on Bikini, Kwajalein, Majuro, Ponape, and Kusaie (Fig. 2.2). A detailed description of equipment used at each of these points is given in Chap. 3. Emplacements for the land stations on Eniwetok Atoll were constructed by Holmes and Narver from specifications furnished by project personnel. Stations outside the Atoll required no special installations. On Majuro, Ponape, and Kusaie, task force weather units assumed responsibility for the operation of the stations. Since the equipment on Bikini and Kwajalein was more extensive, these stations were operated by project personnel.

A station on Wake had been planned, but it was abandoned because of typhoon damage. No station was planned for Guam since it was assumed that the possibility of fall-out there was very remote. The island of Ujelang to the southwest is the nearest island to Eniwetok. Although it was not possible to locate a station there, one was installed aboard a Navy LST which was standing off the island to evacuate island personnel if such action was necessary.

Transportation of equipment and personnel to each of the islands was made by periodically scheduled PBM aircraft.

11

UNCLASSIFIED — RESTRICTED DATA — SECRET — SECURITY INFORMATION — UNCLASSIFIED

UNCLASSIFIED

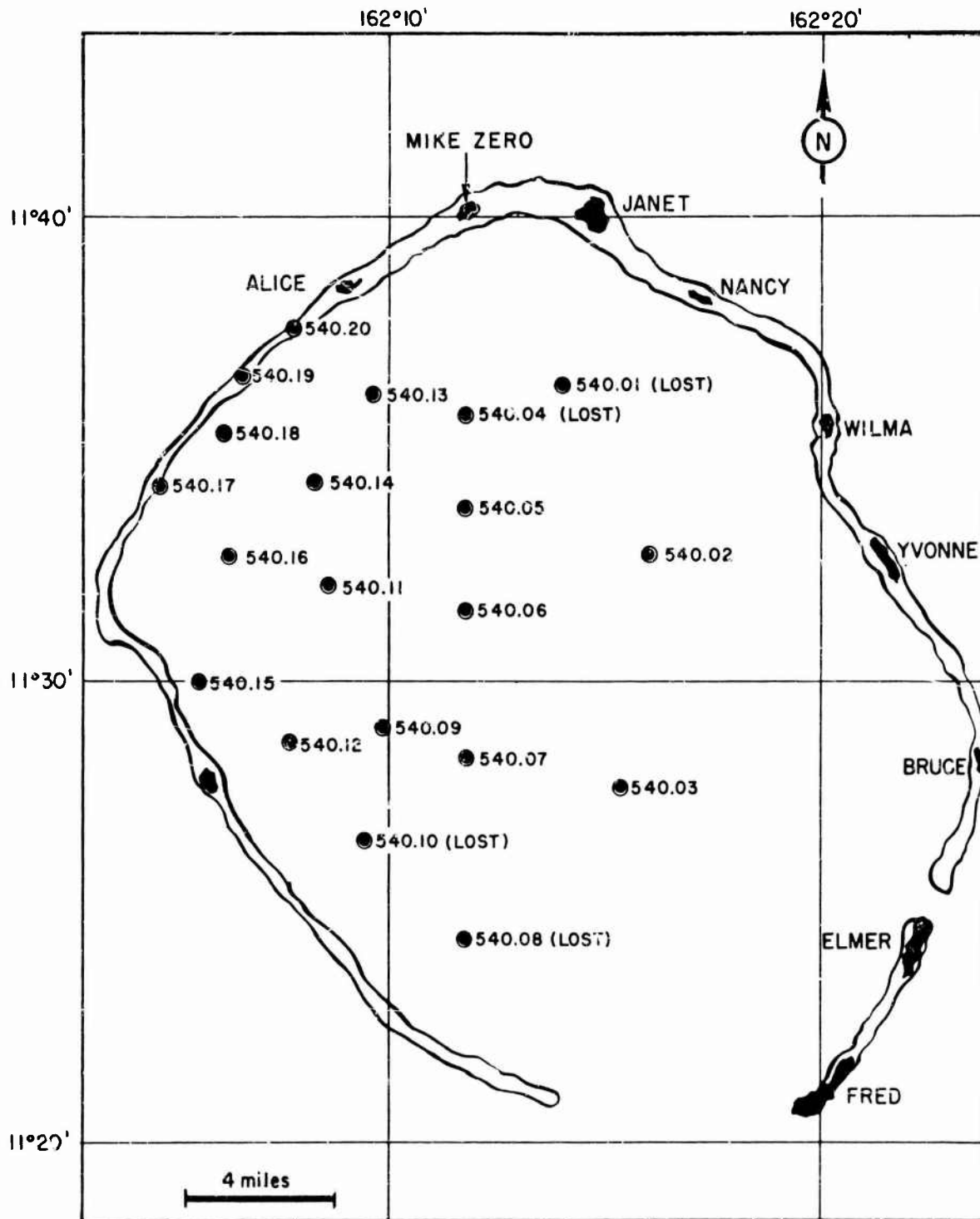

Fig. 2.1—Eniwetok Atoll stations.

RESTRICTED DATA—SECRET—SECURITY INFORMATION  
UNCLASSIFIED UNCLASSIFIED

UNCLASSIFIED

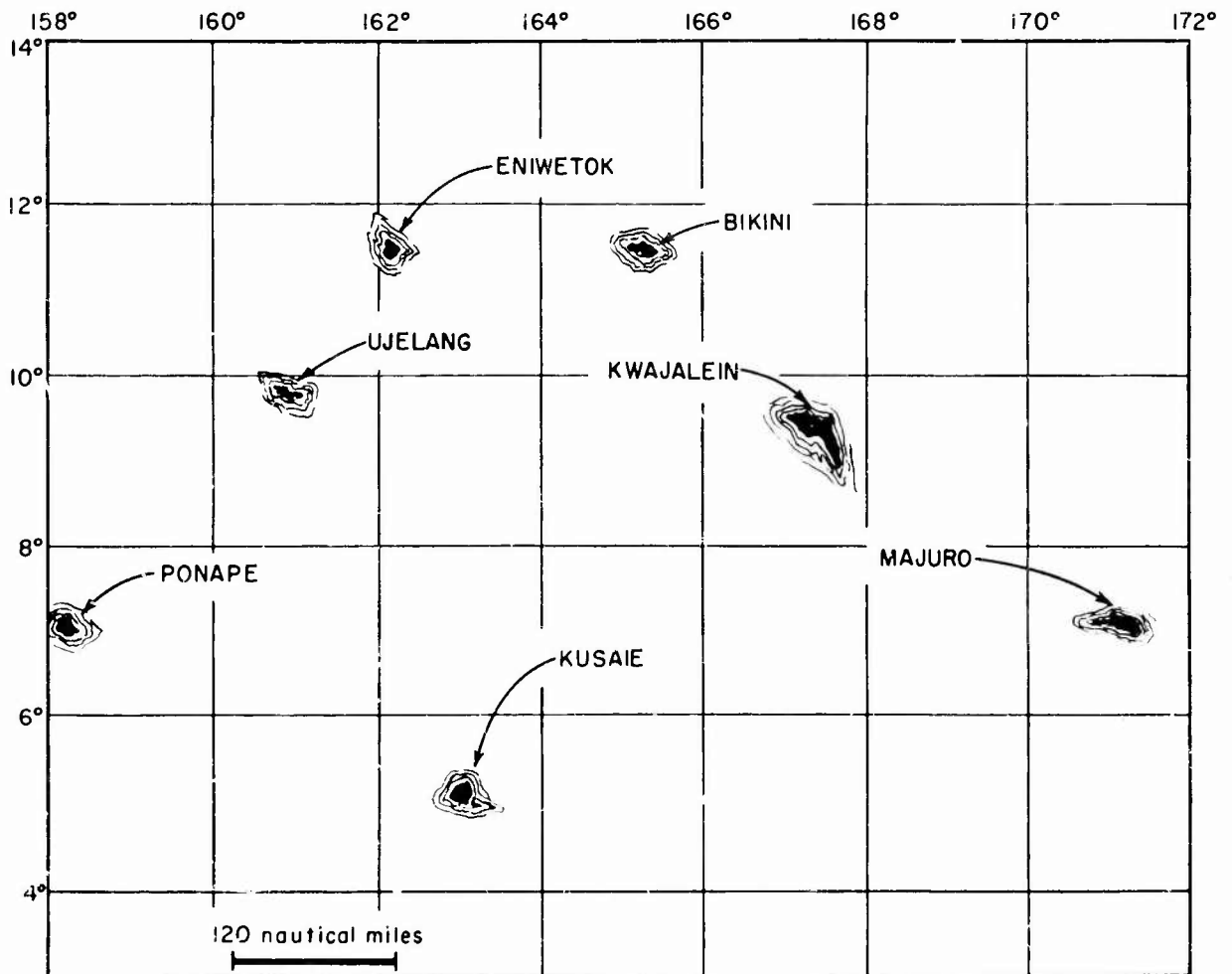

Fig. 2.2—Outer island stations.

RESTRICTED DATA - SECRET - SECURITY INFORMATION  
UNCLASSIFIED UNCLASSIFIED

**UNCLASSIFIED**  
**SECRET**

## 2.2 LAGOON STATIONS

Twenty stations within the Eniwetok Lagoon (Fig. 2.1) were mounted on standard Navy 60-man life floats fastened to moorings provided by Holmes and Narver. The anchor for each mooring was a 4000-lb concrete block to which a discarded oil drum was attached as a float. A 1-in. wire cable, which was one-third greater in length than the depth of the water, was shackled to the anchor and made fast to the float by passing it through two pad eyes welded to the drum and then secured by clamping on itself. An LSU with a crane aboard placed the anchors. Engineers stationed on two of the Atoll islands maintained radio contact with the LSU and directed it to the proper positions. All instruments were installed aboard the life floats at Parry Island. These floats were then loaded aboard an LSU and taken to the designated mooring. Once at the mooring a crane placed the floats in the water. An LCM then towed the float to the mooring, where it was secured to the pad eye on the top of the drum with 100 ft of 3-in. manila line. This phase of the operation was completed by M-15 day.

Two teams using LCM's visited each location approximately one week after the initial installation and again on either M-3 or M-2 day for final adjustment of the equipment aboard the floats. A dinghy, which had been towed to the location, was used to board the floats to avoid any possible damage to the equipment should the LCM and the float bump together.

Of a total of 20 life floats, two were discovered to be missing at the end of one week. In each instance, both the float itself and the oil drum to which it was fastened were missing. It is assumed that the failure occurred where the cable was clamped on itself after passing through the pad eyes on the drum or at the anchor.

During a storm on the night of M-4 day and also on M-3 day, four life floats broke loose. Although a 3-in. manila line was used, it was chafed apart about 3.5 ft from the shackle. It is believed that, as the float swung, the line became wedged in the V created by the clamping of the wire underneath the drum. On M-2 day a short section of wire was added to the mooring lines to eliminate further difficulties of this kind. Two of the four floats which broke loose lodged on the reef only about one-quarter mile off their original position, and samples were recovered from them after the shot.

## 2.3 SEA STATIONS

Because of the depth of the water surrounding Eniwetok Atoll, it was not operationally feasible to place any number of moored floats outside the lagoon. The 500-fathom curve runs approximately 1 mile from the edge of the reef. By 5 miles the depth increases to about 1000 fathoms and beyond that rapidly approaches depths between 2000 and 3000 fathoms. The use of ships in the area and a type of free-floating station were the obvious solutions for extending the collecting area.

### 2.3.1 Shipboard Stations

Fall-out stations were installed on 10 task force ships [see Appendix D for Appendix I, Task Group 132.1 (TG 132.1) Operation Order]. A description of the collectors used on shipboard will be found in Chap. 3. Mounting the collectors aboard the ships was relatively easy. Operational movements of the vessels in a few instances required close coordination between ship and project personnel in placing the equipment aboard, instructing ship personnel in operation of the equipment, and the recovery of the samples for air shipment to the United States. The additional variable introduced in the measurements by the movement of the collector was virtually eliminated by keeping a careful record of the ship's position at stated inter-

**RESTRICTED DATA - SECRET - SECURITY INFORMATION**  
**UNCLASSIFIED**  
**UNCLASSIFIED**

**UNCLASSIFIED**  
**SECRET**

vals. Since all task force ships were equipped with a washdown system, some difficulty was encountered in mounting the collectors at a position which was above the spray from this system. However, location on the highest platform on the mainmast was satisfactory.

### 2.3.2 Free-floating Stations

One reason for approving this phase of the project was to ascertain the operational feasibility of a system of free-floating stations (Fig. 2.3). A system of free-floating stations to measure fall-out over sea areas was first proposed during the early planning for Operation Windstorm, but these tests were subsequently moved to Nevada, and the scheme was never tried. From the start it was realized that such an undertaking presented many problems.

As first conceived, the plan called for the use of a raft which would be large enough to support the collection devices and provide a working platform for personnel to make instrument adjustments after the raft was in the water. As the time approached for establishing definite instrument requirements, information on the number and types of ships which would positively be available for the project was almost entirely absent. Therefore plans were modified to provide for a float smaller than a raft and one which could be placed over the side in a minimum of time without the use of a crane or special rigging. Operationally this plan permitted a maximum flexibility since the number of collection stations which could be placed depended almost entirely on the number and speed of the ships available rather than on space and weight limitations imposed by the float. The float finally selected was a standard Navy type 3 Dan buoy (Fig. 3.10). The buoy weighed less than 75 lb when completely assembled with identification and collection devices. The reserve buoyancy of the float was about 80 lb.

The compact light buoys simplified the problem of their launching and recovery from the sea. The problems involved in launching the buoys so that they would drift to the proper position by shot time and locating them after they had been drifting in the open sea for several days are apparent. It was necessary to assume that the shot would occur on the day and hour scheduled. Delay of the shot for several hours would not have been too serious; however, postponement exceeding about 30 hr would have necessitated repositioning of buoys or the launching of additional ones.

It was assumed that each buoy, when equipped with a sea anchor, could be expected to drift with the current and not be affected appreciably by the wind. Available information about the direction and rate of flow of ocean currents in the Marshall Islands area during the months of October and November was extremely limited. Those data which are available have been developed largely from Japanese prewar charts. The best estimate obtained from the Navy Department Hydrographic Office was that the direction of movement was essentially to the westward at a rate of about 17 nautical miles per day. Upon arrival at the site, two buoys were launched to investigate this estimate. One buoy was launched without a sea anchor; its movements followed the pattern of the wind direction and speed. The other buoy was launched with a sea anchor about 35 miles due east of the deep entrance to Eniwetok Lagoon and was recovered about 5 miles off the Eniwetok reef. The recovery position was not one-quarter mile off a due west line from the launching position. The rate of drift was 18 nautical miles per day. Since this information essentially confirmed earlier predictions, a 270° set and a drift of 18 nautical miles per day were assumed to determine buoy launching positions.

It was felt that it might be necessary to launch as early as M-7 day and that recovery search would continue to about M+7 day before being abandoned. This suggestion meant that some of the buoys could be drifting freely for as long as 14 days. The sea areas covered by any pattern of buoy positions would then be extensive. To increase the probability for recovering, each buoy was equipped with a standard MX-138A corner radar reflector. It was mounted at the top of the flagstaff within a special adapter developed by the Mine Sweeping Section of the Bureau of Ships. The radar reflectors were the same type as used in the rubber raft equipment issued to Naval aircraft. The use of the radar reflectors was absolutely necessary if the

**RESTRICTED DATA - SECURITY INFORMATION**  
**UNCLASSIFIED**

UNCLASSIFIED

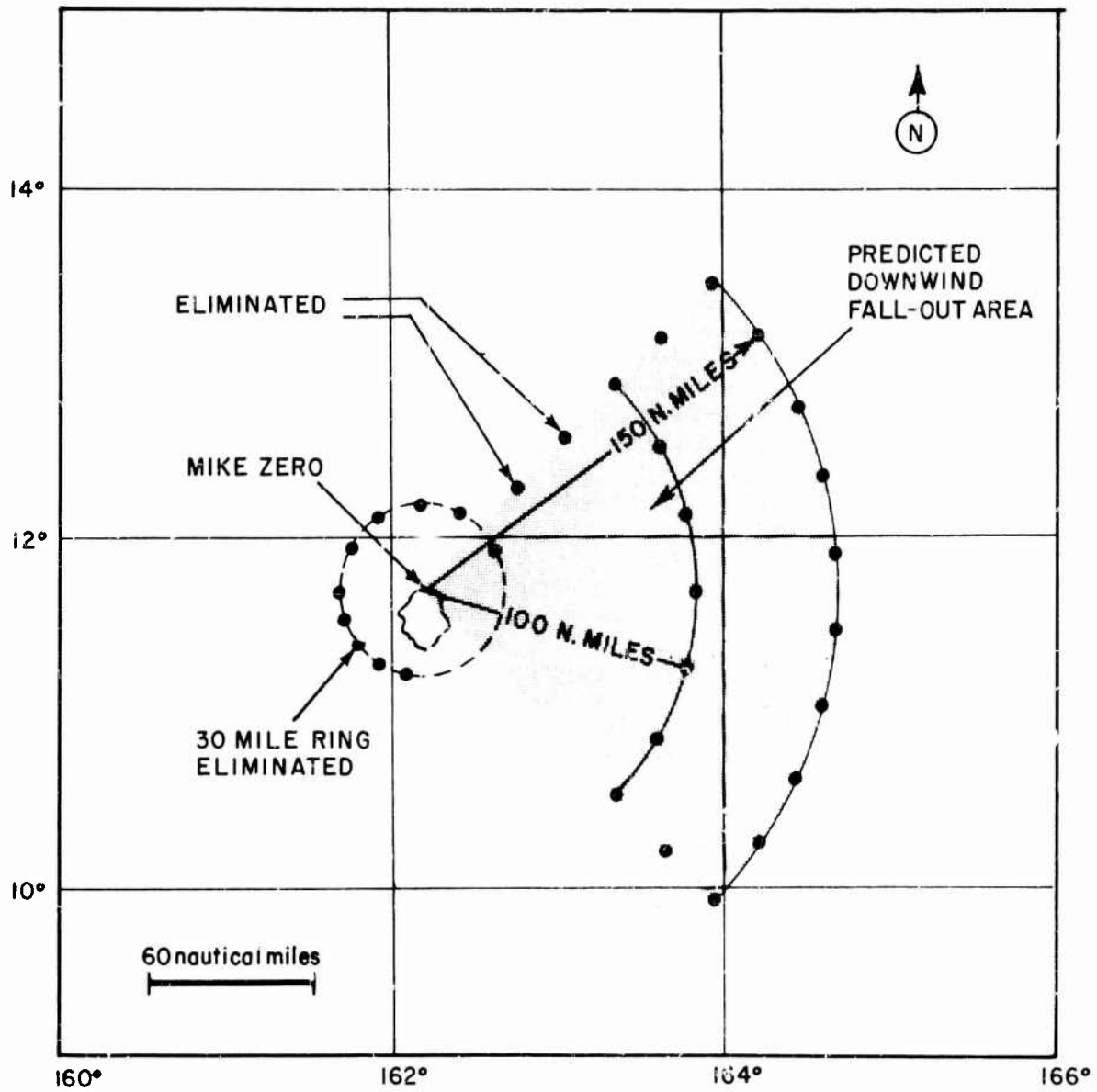

Fig. 2.3—Free-floating sea-station array.

# UNCLASSIFIED

majority of the buoys was to be recovered. However, the use of radar reflectors posed a security problem since the pip received from the reflectors could not be differentiated from that received from any other object, such as a submarine. Thus any ship or aircraft making radar contact would also have to make visual contact in order to identify the target positively. This visual contact would not always be feasible because the search aircraft or ships would have to be diverted from their primary mission for such identification. To partially overcome this objection, the number of buoys was reduced to about thirty so that the Navy Task Force could keep track of this relatively small number and forewarn units searching the area. Planning within the task force was undertaken on this basis, and the somewhat increased security risk was considered acceptable by the Task Force Commander.\*

As additional aids for the location and identification of the buoys, each one was equipped with an alphabet signal flag, and the staff over a short section was wrapped with paper with a reflective surface such as used in billboard advertising.

### 2.3.3 Operational Success

Of the 19 buoys placed, 12 were recovered by the USS O'Bannon. One buoy was picked up by another ship to the west of Eniwetok (10° 41' N latitude and 158° 42' E longitude) on 13 November, and the collected sample was returned to the laboratory. One buoy was reported to be lodged on the reef at Eniwetok and could have been recovered, but was not. The average set of the buoys was 286° with a drift of 0.70 knot. This is compared with an estimate of 270° for the set and 0.75 knot for the drift (see Appendix D for observed set and drift of the buoys).

As a result of the error in estimated position, the search for the first buoy was undertaken to the south of the actual position. The search began about 0400 on 2 November, and the first buoy was not recovered until 1810 that day. Once the first buoy had been recovered, the lapse of time between picking up the remaining buoys was not generally so great. Sea anchors for buoys 17, 18, 19, 2, and 5 were missing when the buoys were recovered. These buoys had been in the water for the longest time, and it is believed that the loss of the sea anchors resulted from the chafing of the line. The poor percentage of recovery of buoys 1 through 8 is attributed to the probable loss of their sea anchors. The use of wire or satisfactory thimbles and shackles should prevent similar difficulties in future operations.

It is believed that the percentage of recovery of sea stations in this test definitely establishes the operational feasibility of their use in the collection of fall-out.

It is recommended that a coded signaling beam be used on each buoy in future operations to assure positive identification of these free-floating sea stations and to eliminate any interference with the security patrol. Such a device should operate on a unique frequency band, be undetectable by the task force security vessels, and not respond to any common radar frequencies. The British Air Sea Rescue beacon satisfies these requirements. It weighs very little and can be easily installed on a small buoy. Special portable receivers, which will home on any one of a group of signals coming from a concentrated area, are available for these beacons. These receivers have a range of about 65 miles when used aboard an aircraft flying at 10,000 ft and a range of 3 to 10 miles when used aboard a surface craft.

---

\*On M-6 day, instructions were received from the Office of the Commander-in-Chief, Pacific Fleet, that use of the buoys imposed unacceptable limitations on security from submarine penetration and that the area out to 75 miles from the shot island must be kept clear of the buoys. This directive eliminated all but 19 of the buoys and reduced the placement of stations to that area downwind of the predicted upper air winds, i.e., on two 90° arcs, one at 100 miles and the other at 150 miles to the northeast of the atoll.

17  
RESTRICTED DATA - SECRET - UNCLASSIFIED

~~UNCLASSIFIED~~  
~~SECRET~~

## CHAPTER 3

### INSTRUMENTS

From the beginning it was thought that the fall-out from Mike shot would consist of both solid and liquid radioactive samples. The solid particulate samples were expected to come from the destruction of the shot island, and the liquid samples were expected to consist of rain and any lagoon water blown into the air by the explosion. Therefore instruments were especially designed to collect either type of fall-out.

Furthermore, because of the limitations imposed by the geography of Eniwetok Atoll, the instruments had to be adaptable to both land and sea stations for a 360° coverage to be made around the shot island.

#### 3.1 DESIGN CRITERIA

The instrument designs were based on specific collecting requirements and limited by certain mechanical and electrical restrictions. Estimates of the problems posed by the action of the bomb and effects arising from environment in which the instruments were to be used were also considered in establishing the criteria for instrument design.

##### 3.1.1 Collecting Requirements

The instruments were designed to meet the following collecting requirements:

1. To collect solid or liquid fall-out segregated with respect to time of arrival.
2. To collect total fall-out.
3. To collect particles for their size measurements.

##### 3.1.2 Mechanical and Electrical Restrictions

The mechanical and electrical restrictions that were imposed on the design of the equipment required that it be simple to manufacture, utilizing commercial products wherever possible. It was to be light and easy to service in the field. Furthermore the equipment was to operate simply and positively under all rigorous conditions of field use.

##### 3.1.3 Pressure and Thermal Effects Expected from the Bomb Burst

The problems posed by the bomb burst primarily involved designing the equipment to withstand the estimated pressures and heat produced when the bomb was detonated. In general, the equipment was designed or shielded to withstand at least a pressure of 7 psig, which pressure was estimated to occur about 5 miles from ground zero for a 5-Mt bomb. The estimated thermal effects were from 25 to 50 cal/sq cm for this same distance, and the equipment was designed to withstand at least the lower value for short exposure. Considerable time was spent in testing materials for their thermal resistance properties.

18  
~~UNCLASSIFIED~~ RESTRICTED DATA - SECRET - SECURITY INFORMATION ~~UNCLASSIFIED~~

UNCLASSIFIED

### 3.1.4 Environmental Requirements

The site where the equipment was to be used made it necessary that the equipment operate in a warm and humid climate. Also, the instruments had to be capable of operation when out on the water and be unaffected by wave action. Tests were made on the resistance that materials offered to corrosion, as well as the mechanical functioning of the instrument under adverse conditions.

### 3.2 TOTAL FALL-OUT COLLECTOR

The total fall-out collector consisted of a 1-gal polyethylene bottle and a 6-in. funnel connected to it by tygon tubing (Fig. 3.1). Polyethylene and tygon were used because of their chemical inertness; also, the polyethylene bottles could be dropped without breaking.

The total fall-out collector was considered a safety measure to ensure a collection of fall-out in case other instruments failed.

### 3.3 DIFFERENTIAL FALL-OUT COLLECTOR

The differential fall-out collector was designed to collect solid fall-out particles as a function of time. The unit consisted of a lucite tray divided into 72 compartments, a varnished Fiberglas slotted belt that was pulled over the tray exposing each compartment individually, a 6-volt Magnatorc motor to pull the belt, a battery for the source of power, and a trigger mechanism for starting the motor (Fig. 3.2). Two collecting rates were used; one, at the nearer stations, had approximately 2-min collecting increments, and the other, at the more distant stations, had approximately 6-min collecting increments.

In addition, provision was made to remove the lucite tray, put it in a wooden box, and seal off the compartments by means of a lid that was surfaced on one side with a soft piece of rubber. This lid was then banded to the box, making a watertight seal. This box was used for shipping.

*Trigger Mechanism.* The differential fall-out collector was started at shot time by a trigger mechanism. This mechanism consisted of two light-sensitive circuits: a light-level circuit or phototube circuit and a light-level differential or photocell circuit. Either circuit would trigger the differential fall-out collector, and both circuits had 360° vision (Fig. 3.3), which was essential since these units were used on rafts in the lagoon. Both circuits were adjustable for sensitivity so that the factor of distance from the shot island could be taken into account. The circuit diagram of the trigger mechanism is given in Appendix C.

### 3.4 INCREMENTAL LIQUID FALL-OUT COLLECTORS

These units were designed primarily to collect liquid samples as a function of time. Each consisted of a vertical lucite column divided into sections separated from each other by a ball-float valve (Fig. 3.4). Each section held 0.15 in. of rain. Recording rain gages were used in conjunction with the incremental collectors to determine time of arrival.

### 3.5 RAIN GAGE

The recording rain and snow gage manufactured by The Instruments Corp. was used to measure the rate of arrival of liquid fall-out at two recording rates. One instrument made a 7-day trace, and the other made a 3.5-day trace. This instrument is used by the United States Weather Bureau (Fig. 3.5).

RESTRICTED DATA - SECRET - SECURITY INFORMATION  
UNCLASSIFIED UNCLASSIFIED

**UNCLASSIFIED**

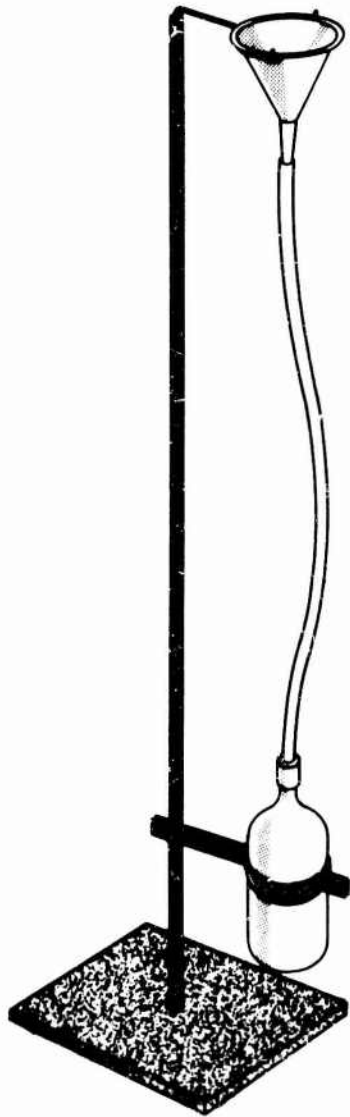

Fig. 3.1 — Total fall-out collector.

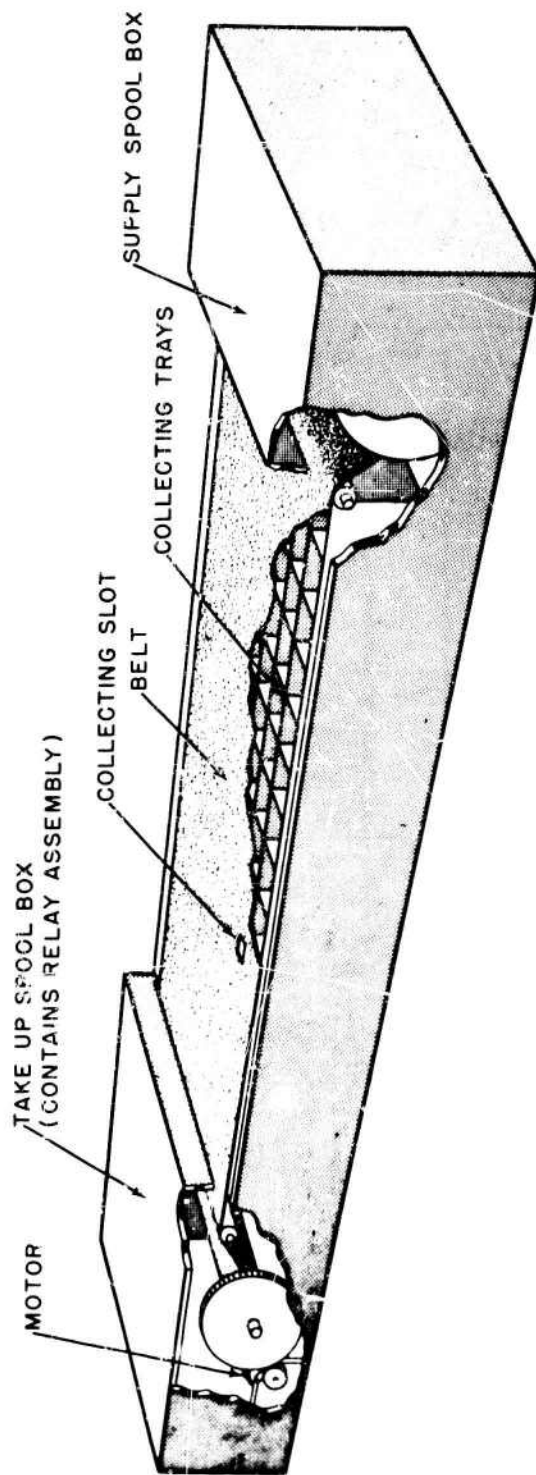

Fig. 3.2—Differential fall-out collector.

RESTRICTED DATA - SECRET

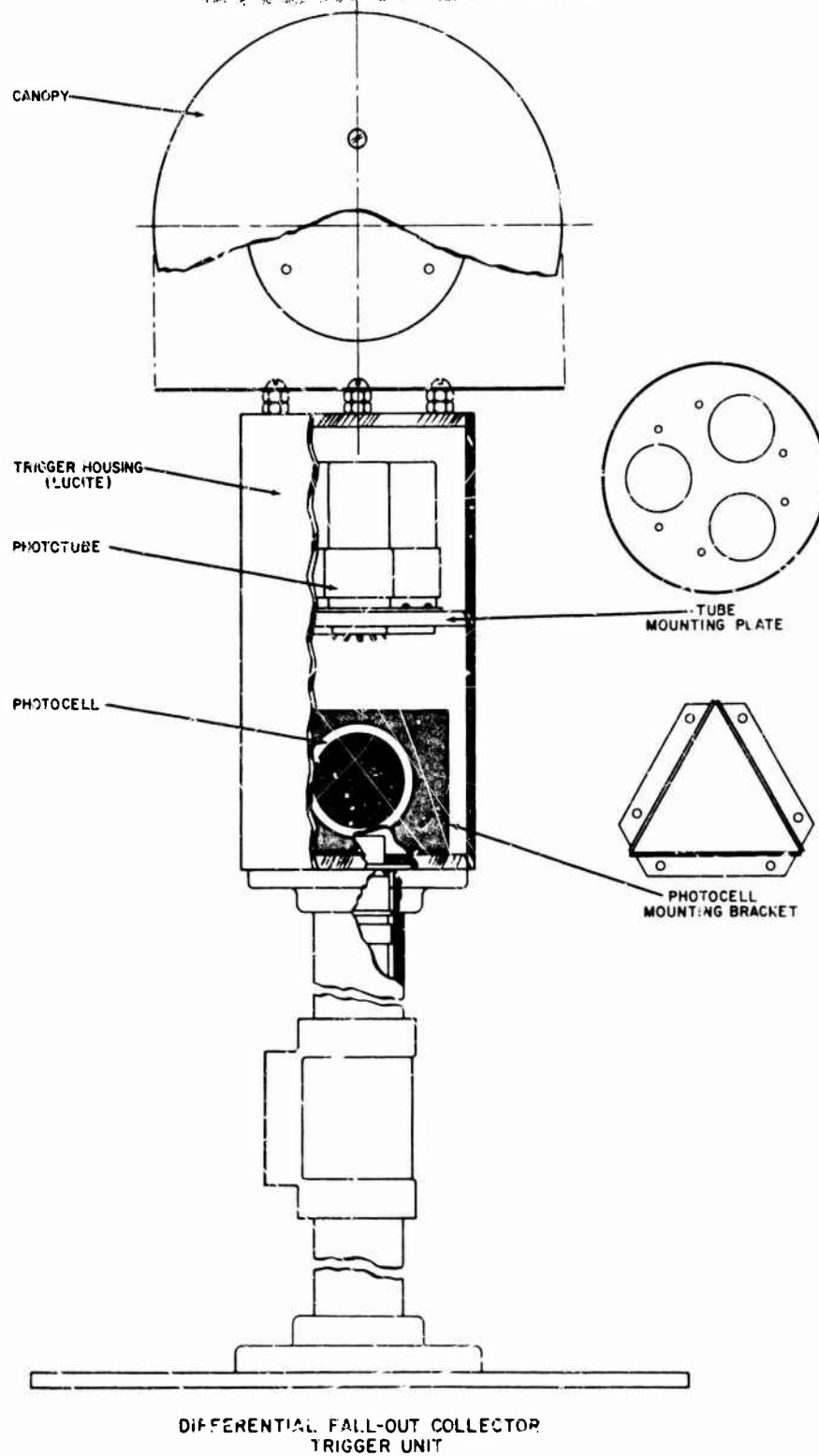

Fig. 3.3—Light-actuated trigger mechanism.

UNCLASSIFIED

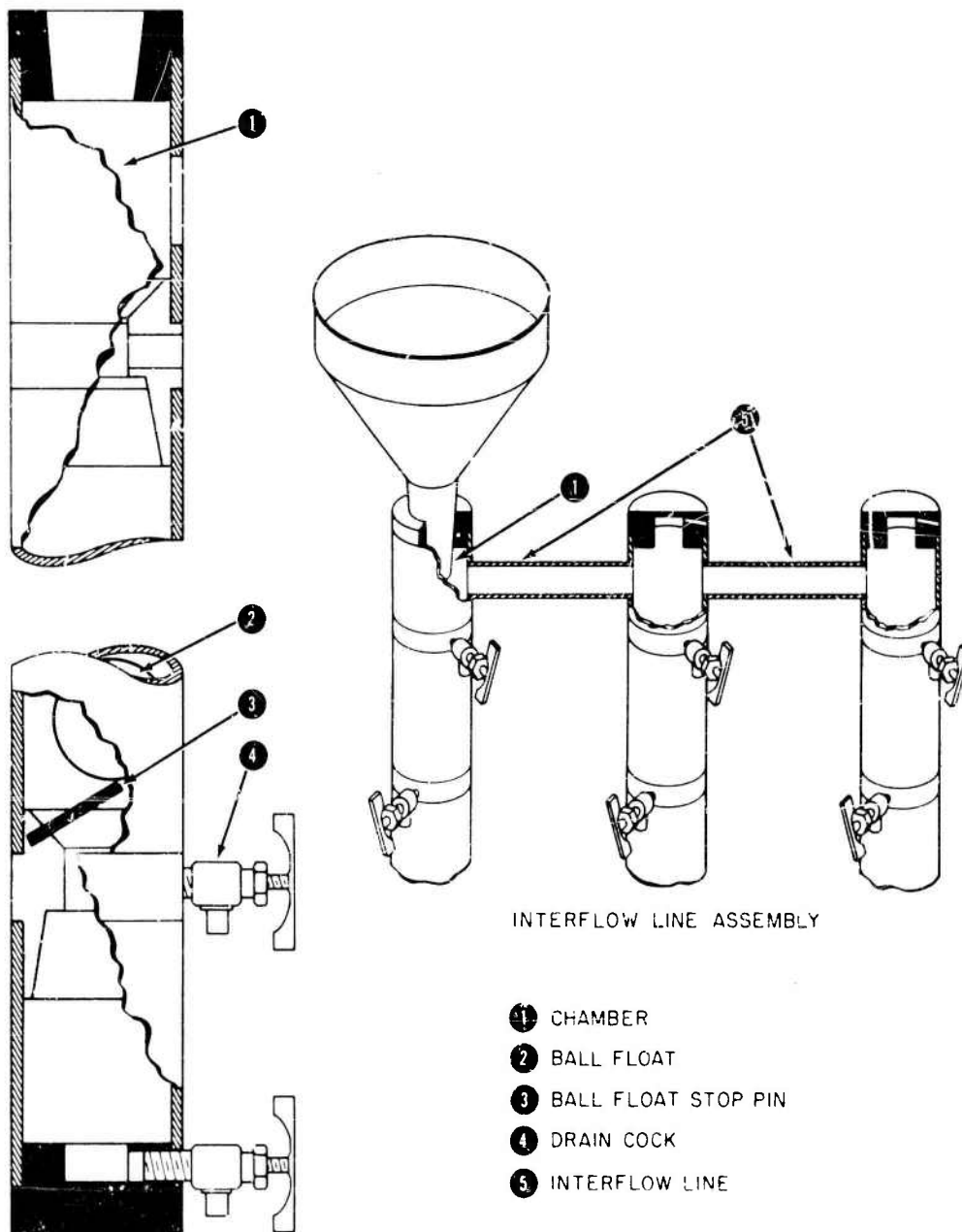

Fig. 3.4—Incremental liquid fall-out collector.

UNCLASSIFIED

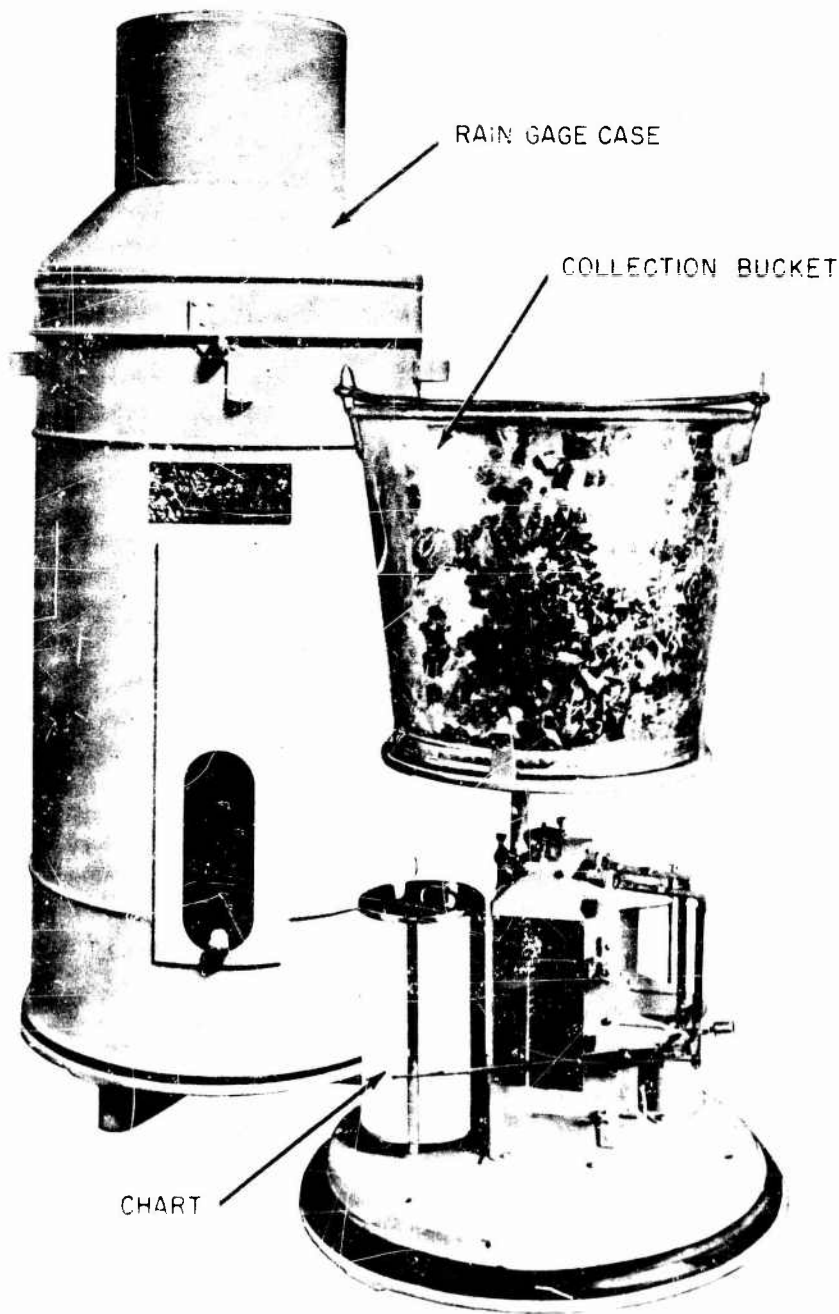

Fig. 3.5—Recording rain gage.

**UNCLASSIFIED**  
**SECRET**

### 3.6 ION-EXCHANGE COLUMNS

Ion-exchange columns were placed at some of the stations to test their suitability as collecting devices. They consisted of a lucite column filled with Dowex-50 or Amberlite XE-81 (now designated as Amberlite MB-1), a funnel, and a polyethylene bottle to collect the effluent (Fig. 3.6). It was hoped that the use of these columns would preserve the contaminant in its original state and allow the components to be investigated by elution with different reagents.

### 3.7 GUM-PAPER COLLECTOR

This collector consisted of a 2-ft square of Kum-Kleen gummed paper mounted on cardboard. Ten days' supply of this paper was shipped to each collecting station, where the operator had only to remove the protective cover and expose the gummed surface to the fall-out. Exposures were changed either at 12- or 24-hr intervals over a period of 5 to 10 days. These units were primarily designed to collect fall-out at great distances from the shot island and were sent to various neighboring atolls as well as installed on certain task force ships (Fig. 3.7).

### 3.8 AIR SAMPLER

An air sampler was installed on the island of Nancy. This unit consisted of a motor-driven filter-paper belt and a blower having a capacity of 4 cu ft/min. It was designed to trigger at shot time and record total activity with time over a 1-hr period.

### 3.9 DESIGN OF STATIONS

There were three basic types of stations: land, lagoon, and sea stations. In addition there were stations aboard task force ships and at neighboring atolls.

The land stations on Eniwetok Atoll islands consisted of a concrete shield and platform so placed that the collecting instruments were protected from blast and thermal effects (Fig. 3.8). The thickness of the shield varied with the distance from the blast. The concrete platform was equipped with studs for mounting the instruments. At these stations the following instruments were used: total collector, differential fall-out collector, incremental collector, two rain gages, and an ion-exchange collector. The rain gages had different recording rates. Those instruments which had to be started at shot time were started by a trigger actuated by light from the bomb.

The lagoon stations were modified Navy 60-man life floats. A deck was built over the top of the float, and a breakwater, which consisted of a cross-hatched wooden planking, was installed beneath it. A gimbal mount was installed on the life float to hold a rain gage, and a 0.375-in. steel shield was installed around the rain gage to protect it from blast damage. This gimbal mount had a submerged vane to damp the oscillations created by the waves. In addition to the rain gage, the floats were equipped with an incremental collector, differential fall-out collector, total collector, and trigger mechanism (Fig. 3.9).

The sea stations were free-floating standard Navy type 3 Dan buoys (Fig. 3.10). They were equipped with a total collector and a 1-ft square of Kum-Kleen gummed paper mounted on the corner reflector.

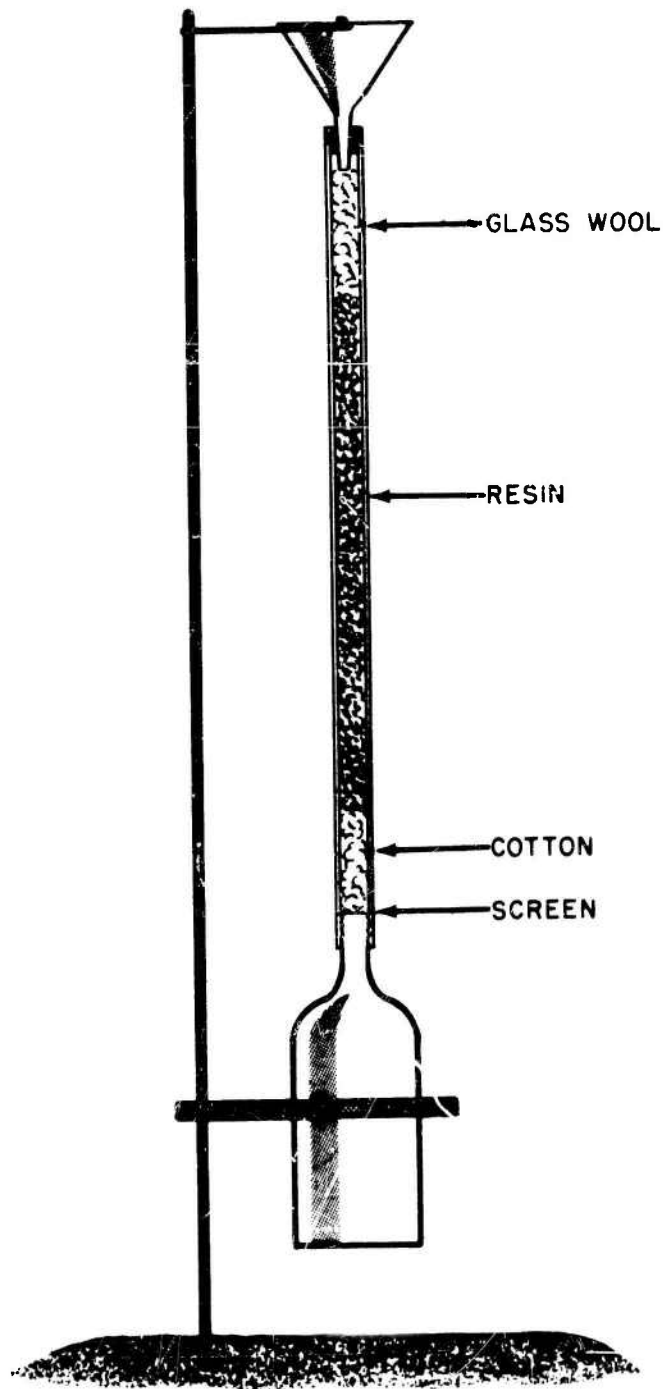

Fig. 3.8—Ion-exchange-column collector.

RESTRICTED DATA - SECRET - SECURITY INFORMATION

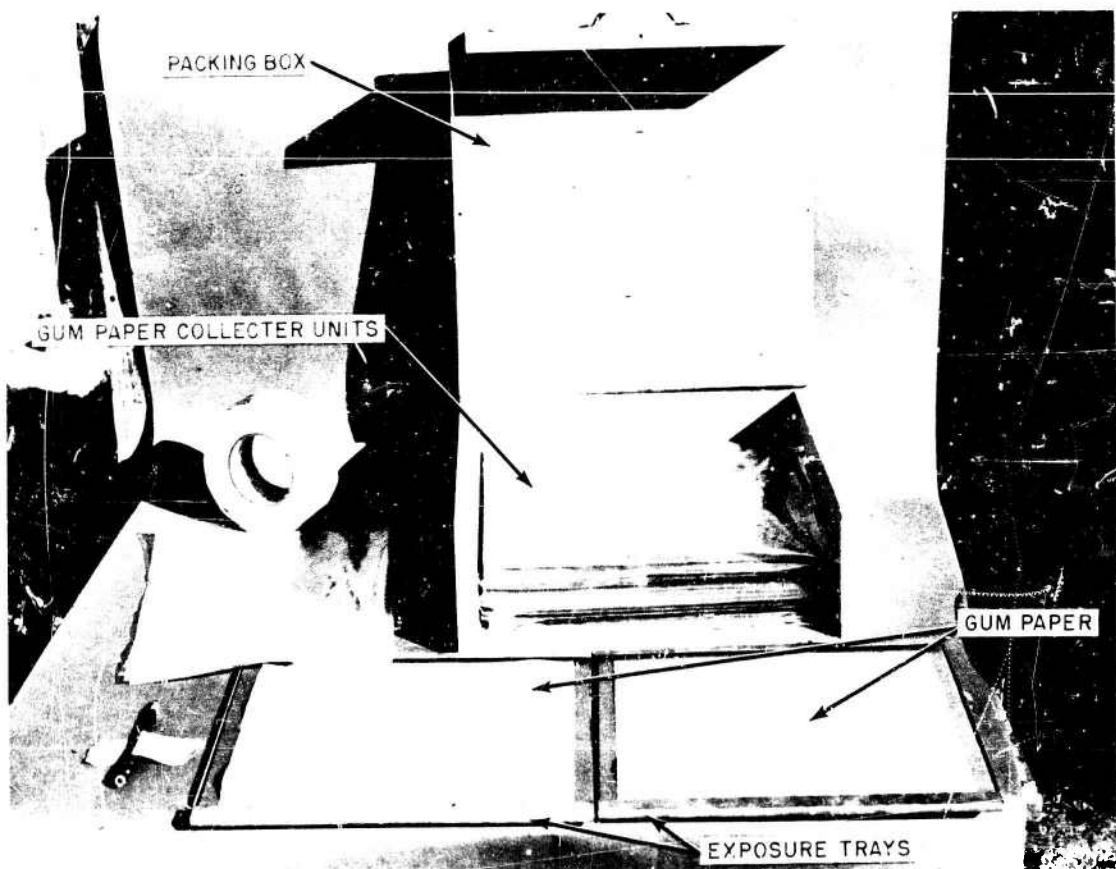

Fig. 3.7—Gum-paper collector kit.

**UNCLASSIFIED**

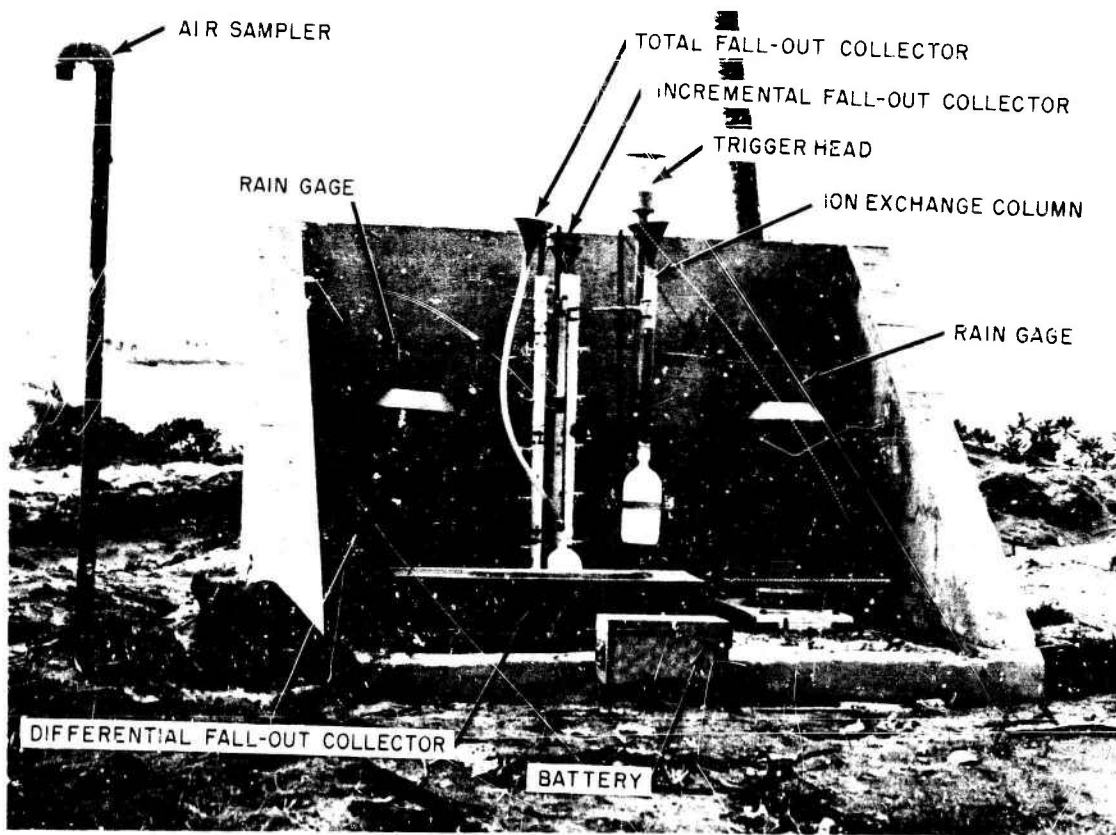

Fig. 3.8—A typical land station.

UNCLASSIFIED  
SECRET

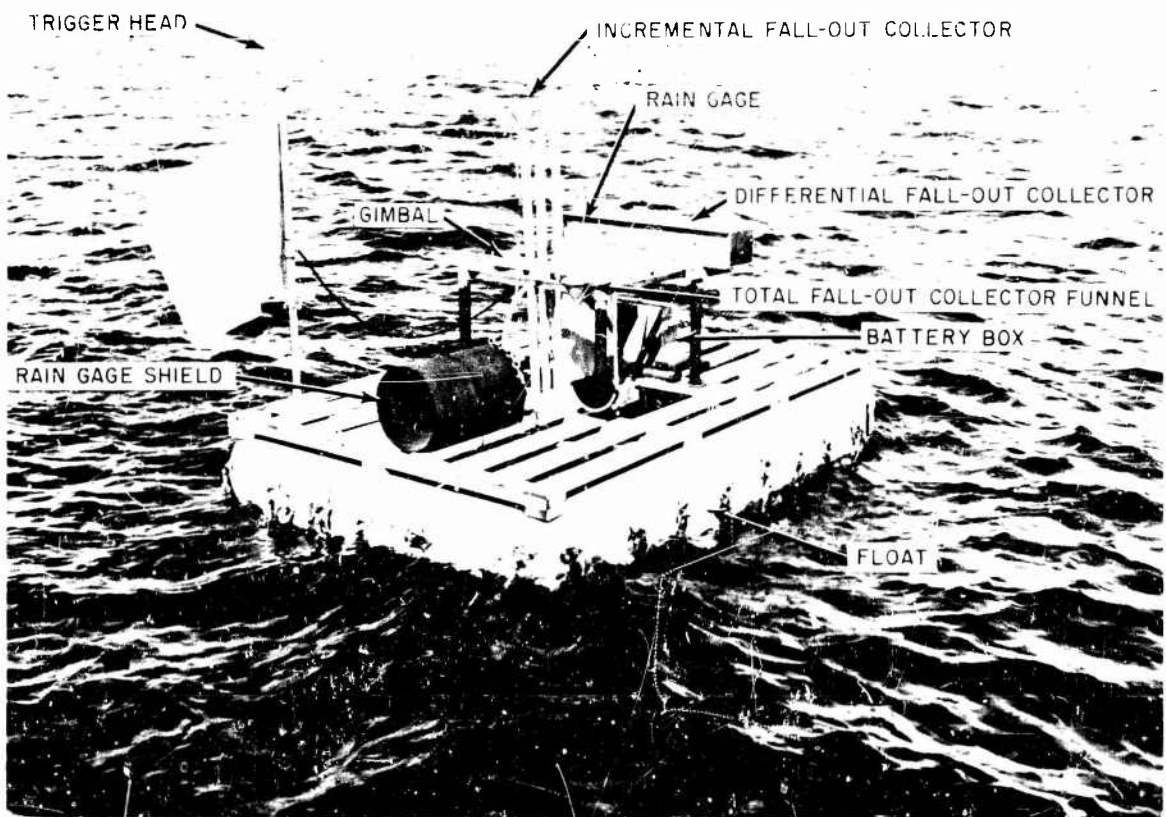

Fig. 3.9—A typical lagoon station.

**UNCLASSIFIED**

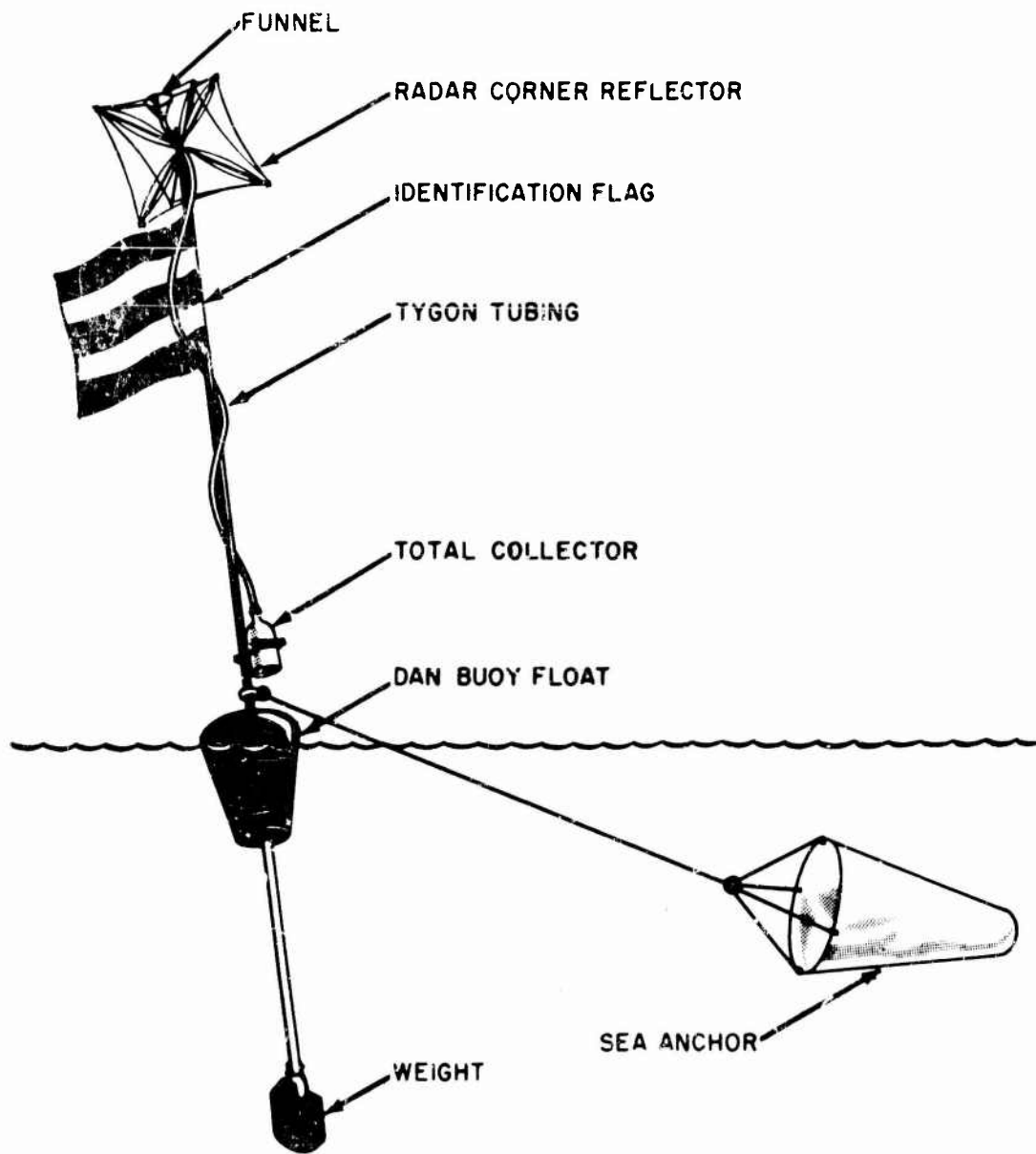

Fig. 3.10—Free-floating sea station.

# UNCLASSIFIED

## 3.10 EVALUATION OF INSTRUMENTS

### 3.10.1 Rain Gage

The land-based rain gages operated successfully where they were not damaged by blast. The biggest difficulty experienced with the rain gage was that the inking system was not designed for writing on a floating support even when provision had been made to damp the action created by wave motion by the use of a gimbal. The lagoon was much choppiier than San Francisco Bay, where the instrument was initially tested, and as a consequence the ink in the pen was rapidly used up in drawing a very broad high-frequency trace. This necessitated changing to an improvised smoked chart on which the dry pen acted as a stylus. The tracings were sprayed with Krylon when they were recovered, to prevent smearing. This improvisation did not eliminate the broadness of the trace caused by the action of the waves. Therefore, although large changes of rainfall were readily apparent, small increases that may have occurred during the fall-out were not.

The shields for the rain gages as employed on the lagoon stations were very effective. None of the lagoon-based rain gages suffered damage, and only the closest received thermal burns on the unshielded top surface area. The land-based rain gages which were not shielded, on Alice and Janet, were damaged severely by blast.

When rain gages are used afloat, the following items should be checked to assure the most satisfactory results: polyethylene or some such inactive plastic bucket should be used if the fall-out is to be recovered; the tracing device should be modified so that it is less sensitive to motion and more positive in its action; a circular type gimbal mount for the rain gage would provide better stability; and the shielding of the rain gages by a steel tube should be accomplished on all close-in stations.

The use of rain gages ashore presented no great problem, and the type used was satisfactory where information accurate to  $\pm 0.05$  in. is sufficient.

### 3.10.2 Incremental Collector

This instrument was designed as a liquid collector and, since the fall-out was composed of particulate matter, no valid conclusions as to its effectiveness could be drawn.

### 3.10.3 Differential Fall-out Collector

The basic design employed in this collector had many valuable features. Moving the aperture rather than the collecting trays eliminated the need of a large power source. The problem of cross contamination of collecting trays was minimized by the close fit between the moving belt and the tray and the fact that, once sealed after collection, the trays were not opened until analysis was begun at the laboratory. Furthermore its relatively light weight, approximately 60 lb exclusive of its external power source, made it easy to handle by one man. The increment rate could be varied by changing gears, and such change allowed for a variation in total collecting time, which was highly desirable.

Besides a failure of trigger mechanisms, the following problems were encountered in the operation of this instrument:

1. The moving belt jammed by sticking in its guides and was torn.
2. In one case the belt-stopping microswitch failed to stop the belt at the proper instant, thereby exposing the tray to the elements.
3. Two of the 6-volt storage batteries shorted out on the lagoon stations.

### 3.10.4 Trigger Mechanism

The bomb-light-sensitive triggers functioned very well. There was one failure on the lagoon stations due to a faulty relay; the land-station triggers operated sporadically and unsuccessfully. The reason for their failure is not known. Probably they experienced some type of thermal shielding.

# UNCLASSIFIED

### 3.10.5 Total Collector

This collector gave no trouble except that some fall-out adhered to the collecting funnel.

### 3.10.6 Ion-exchange Collector

This collector was also trouble free, but, since work is still in progress on the effluent from these columns, no attempt to evaluate them is made.

### 3.10.7 Gum-paper Collectors

No difficulty was experienced in using these collectors. An excellent feature of the Kum-Kleen adhesive was that, upon exposure, the surface tended to become more tacky rather than drying.

### 3.10.8 Résumé of the Operation of the Instruments

Table 3.1 shows the disposition and performance of the instruments used at the land and lagoon stations at Eniwetok Atoll.

Table 3.1 — INSTRUMENTATION AT LAND AND LAGOON STATIONS AT ENIWETOK ATOLL

Station	Distance, ft	Total collector	Rain gage	Incremental collector	Differential collector	Trigger	Life float	Remarks
540.20	26,400			Funnel blown off			Moved on- to reef	
540.13	27,050	OK	OK	1½ columns blown off	Belt pulled through	OK	Burned slightly	
540.04	26,400							Lost before shot
540.01	26,400							Lost before shot
540.19	33,000			OK			Moved on- to reef	
540.14	39,800	OK	OK	OK	Belt jammed	OK	OK	
540.05	39,800	OK	OK	OK	Belt tore	OK	OK	
540.16	44,800	OK	OK	Valve open	OK	OK	OK	
540.17	47,520			OK			Moved on- to reef	
540.02	52,800	OK	OK	OK	Belt stuck	OK	OK	
540.11	52,800	OK	OK	OK	Relay failed	OK	OK	
540.06	52,800	OK	OK	OK	Belt stuck	OK	OK	
540.16	55,440	OK	OK	OK	OK	OK	OK	
540.09	66,640	OK	OK	OK	OK	OK	OK	
540.07	71,280	OK	OK	OK	OK	OK	OK	
540.15	72,000	OK	OK	OK	OK	OK	OK	Recovered off reef
540.12	73,920	OK	OK	OK	Belt stuck	OK	OK	
540.03	79,200							Lost
540.10	84,460							Lost before shot
540.08	95,040							Lost before shot
Alice	17,440							Equip. demolished
Janet	16,680	Broken	Broken	Broken	Belt stuck	OK		Equip. demolished
Nancy	33,800	OK	Damaged	OK	OK	Did not trigger		
Wilma	57,180	OK	OK	OK	Belt tore	OK		
Yvonne	75,520	OK	OK	OK	OK	Did not trigger		
Bruce	102,870	OK	OK	OK	OK	Did not trigger		
Elmer	115,060	OK	OK	OK	OK	OK		
Fred	124,580	OK	OK	OK	OK	Did not trigger		

# UNCLASSIFIED

## CHAPTER 4

### PRIMARY FALL-OUT

Primary fall-out following a nuclear detonation may be defined as the particulate which arrives at relatively early times and forms a well-delineated pattern downwind from ground zero. This fall-out has considerable military significance. The areas of primary fall-out, particularly from superweapons, are quite extensive, and many hours can elapse before the fall-out gamma field is completely defined.

#### 4.1 GAMMA FIELD

The gamma field following Mike shot was well documented within the lagoon. An analysis of the wind profile at shot time indicated that the downwind fall-out lay over the open sea in a swath west-northwest to north of the island where the shot occurred. The data collected at Eniwetok on the Atoll islands and within the lagoon represent primarily the cross-wind pattern and a portion of the upwind region.

*Observed Gamma Field.* Comprehensive data on the gamma field were obtained within the bounds of Eniwetok Atoll and represent the cross-wind and upwind field. Figure 4.1, showing the gamma field, was compiled from island gamma-survey measurements and lagoon-station gamma- $\dot{t}$  background readings corrected to values representative of the field that would be experienced on an extensive land mass. The gamma values indicated for the lagoon stations are the observed readings multiplied by 7. This multiplying factor results from the relation obtained at Operation Jangle between field gamma readings and gamma measurements of the fall-out from this field as read in a region having a gamma-free background.\*<sup>1</sup> Cessation of cross-wind fall-out was at approximately M+2 hr. The field reaches its maximum intensity† at about this time. Figure 4.1 represents the field at M+2 hr. Extrapolation of gamma intensity to M+2 hr was based on the  $(t^{-1.2})$  decay law.

No activity was detected from gamma-survey measurements taken over the open water in the lagoon. An examination, primarily of the density of fall-out particulate, indicates that the particulate fell rapidly into the lagoon, where it settled on the bottom and left a zero field at the surface. There was some evidence that the lagoon currents carried a small amount of activity southward from the crater; this was measured by actual water sampling, but the activity had such low intensity that it did not generate a gamma field at the surface.

\*It is to be understood that the extension of Jangle relations to the soil and water conditions existing at Eniwetok is open to question. The data presented for the lagoon stations in Fig. 4.1 are simply the best approximations.

†As indicated on the Project 5.3 fall-out gamma time-intensity records.

UNCLASSIFIED

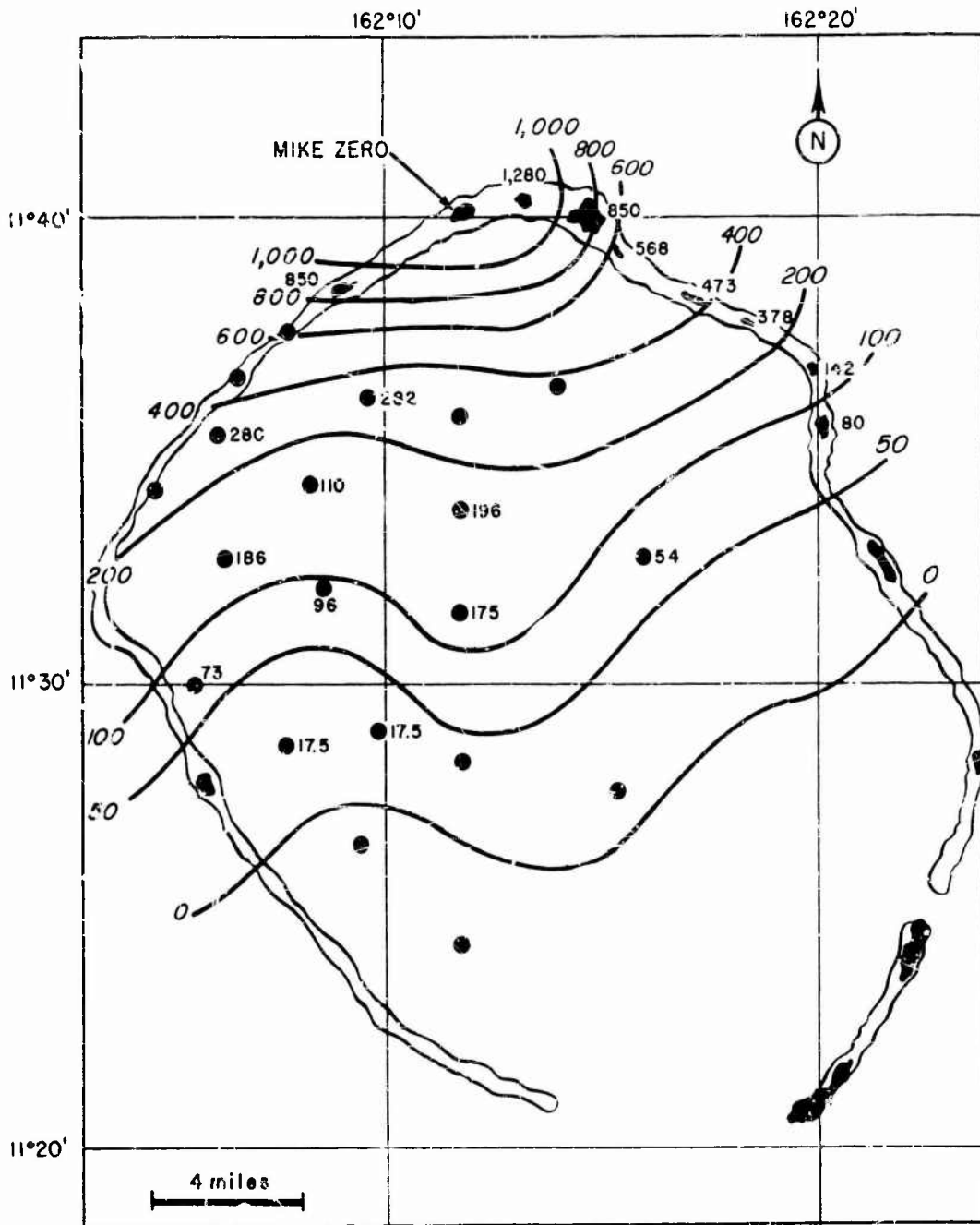

Fig. 4.1—Fall-out gamma pattern at 2 hr as would be experienced on a land mass (t/hr).

UNCLASSIFIED

## 4.2 PHYSICAL AND CHEMICAL NATURE OF THE FALL-OUT

Preshot planning indicated that either liquid or dry fall-out, and probably a mixture of both, would occur. Upon examination of the collected material, especially that which was protected in the differential fall-out collectors, it was concluded that the fall-out was primarily particulate in a dry or semidry state. Several rain showers, apparently over small areas, occurred at shot time and during the fall-out period and caused a fall-out mixture of rain and particulate. This type of fall-out was probably the source of contamination of the survey helicopter (No. 28).

### 4.2.1 Physical Description of Particulate

The particulate, as preserved in its state of arrival, was white and either spherical or irregular in shape (Fig. 4.2); many particles were flaky. Measurements on the larger particles showed their density to be between 1 and 3 g/cu cm. None of these particles were hollow. The floats which constituted the lagoon stations had many particles attached to their surfaces. These particles were also white, but their physical nature was entirely different from that of particles collected in the differential fall-out collectors. The particles were hemispherical and very firmly attached to the float surfaces. Many were hollow, and in some cases their internal structure consisted of a series of concentric shells (Figs. 4.3 and 4.4). These particles were located everywhere on the life floats, including horizontal and vertical surfaces, horizontal surfaces below the water line, the undersides of the horizontal surfaces, and even on the manila line running under water between the life float and its anchoring drum. Figures 4.5 and 4.6 show sections of the decking from the life float located at Station 540.20. The top deck was disturbed by recovery personnel and is not representative of the particle distribution, yet the great accumulation of particles was obvious on the protected second deck even though this deck was spaced only 1.6 in. below the first and completely covered by it. The particles attached to the underside of the first deck are not shown. No explanation is offered for the ability of these particles to seek such well-protected surfaces for deposition; however, it is suggested that, since the surfaces were intermittently wet from sea wash, the wetting aided in retaining the particles.

### 4.2.2 Chemical Composition of the Particulate

Spectrographic analysis of the fall-out particulate is shown in Table 4.1. This fall-out was taken from the float decking and had been exposed to sea water. The main cation constituents are calcium and magnesium. Table 4.2 shows the results of X-ray-diffraction analysis of seven samples from the differential fall-out collectors; these samples were protected from the time of their arrival and consequently were not exposed to sea water or the atmosphere. There is a lack of magnesium here, with the exception of the sample taken at Station 540.14. The particles which were collected in the differential fall-out collectors contained no hydrated calcium sulfate; however, a petrographic analysis of the particles taken from the float sections shows positive evidence of hydrated calcium sulfate. The presence of this material, as well as the preponderance of hollow and quasi-hollow particles on the float decking and their tenacious adherence to the decking, is accounted for by the following theory.\*

It is reasonable to suppose that the fall-out particles originated as calcium oxide, rapidly changing to calcium hydroxide with the formation of a very thin layer of calcium carbonate on their outer surfaces. Generally the radioactivity was irregularly distributed throughout the particles. In some cases there was a tendency for the activity to be concentrated near the surface of the particle.

\*Developed by Charles E. Adams, U. S. Naval Radiological Defense Laboratory (NRDL). This work will be published at a later date.

**UNCLASSIFIED**  
SECRET

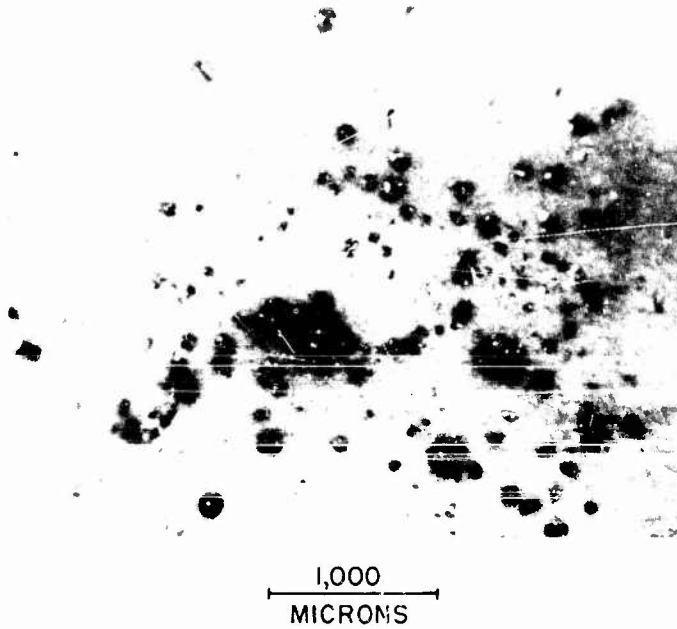
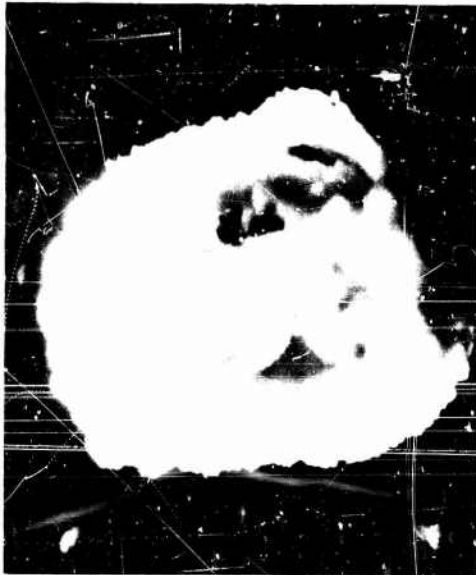

Fig. 4.2—Particles collected by a differential fall-out collector. (Note darkened area around the radioactive particle.)



Fig. 4.3—Plan view of a typical fall-out particle deposited on life-float decking.

UNCLASSIFIED  
SECRET



1,000  
MICRONS

Fig. 4.4—Inverted view of typical particle: removed from life-float decking.

UNCLASSIFIED  
RESTRICTED DATA — SECRET —

UNCLASSIFIED  
RESTRICTED DATA — SECRET —

**UNCLASSIFIED**  
SECRET

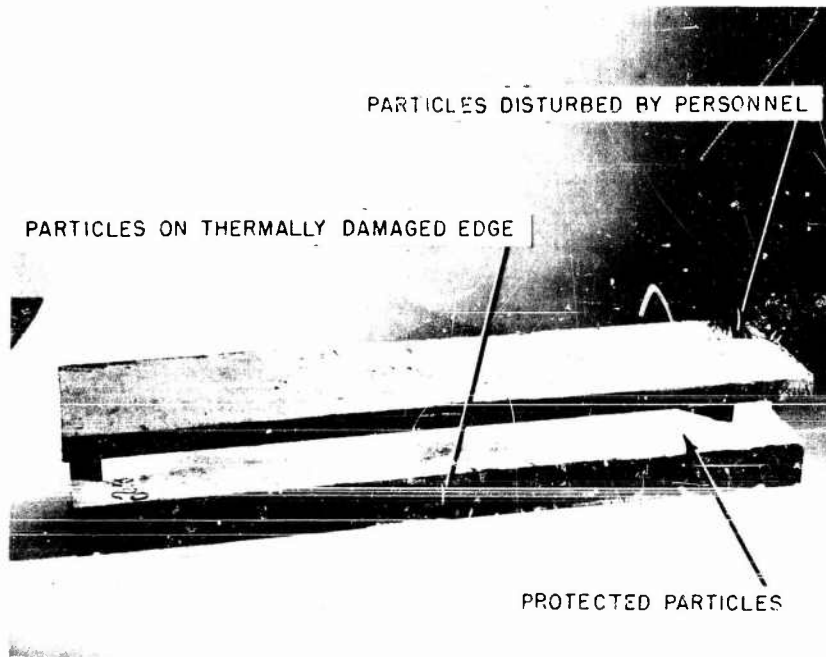

Fig. 4.5—Typical life-float section.

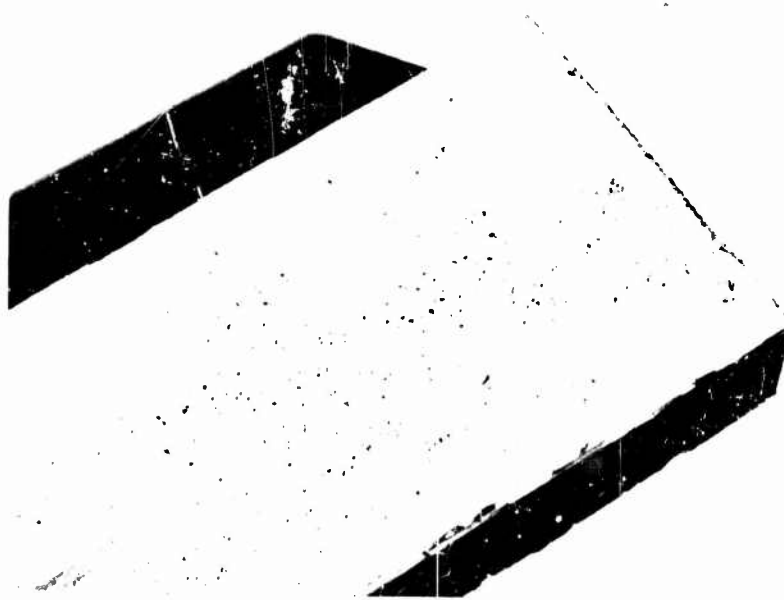

Fig. 4.6—Particle deposition on life-float decking (lower deck of Fig. 4.5).

**UNCLASSIFIED**  
~~SECRET~~

Table 4.1—SPECTROGRAPHIC ANALYSIS OF THE RADIOACTIVE PARTICLES REMOVED FROM THE LIFE-FLOAT DECKING

Element	Strength of lines*
Al	M
Ba	T
Ca	VS
Fe	T
Mg	VS
Mn	T
Na	M
Si	W
Sr	S
Zn	W

\*T = 0.001 to 0.01%.

W = 0.01 to 0.1%.

M = 0.1 to 1%.

S = 1 to 10%.

VS =  $\geq$  10%.

Those particles that were deposited on the life-float decking were influenced by a sea-water environment in which there is a comparatively high concentration of magnesium ion, sulfate ion, and a somewhat smaller one of bicarbonate ion. As the sea water slowly dissolved the slightly soluble calcium hydroxide in the particles, the liberated hydroxide ions reacted with the magnesium ions in the sea water to form a shell of insoluble magnesium hydroxide around the particles. On the exterior of the magnesium hydroxide shell, a layer of calcium carbonate was formed from the dissolved calcium ions and the bicarbonate ions of the sea water. On the interior of the shell, calcium ions from the soluble calcium hydroxide were precipitated by the sulfate ions of the sea water to form a zone of well-developed hydrated calcium sulfate crystals (gypsum).

The prolonging of this leaching and precipitation process caused the formation of either completely or partially hollow particles.

The radioactivity was found to be associated primarily with the inner core of undissolved calcium hydroxide. Little or no activity was found in the magnesium hydroxide-calcium carbonate shell or in the calcium sulfate crystals.

This leaching, by causing a partial solution and reprecipitation of the soluble calcium compounds, accounts for the adherence of the particles to the life-float decking.

#### 4.2.3 Leaching of Activity

The total collectors, consisting of a funnel and bottle, were exposed several days before the shot and were not collected until several days thereafter. Consequently there was a considerable amount of rain water in each collector, as well as a sample of the total fall-out. It was found that the liquid portion collected was active, and analysis of the samples showed that from 14 to 80 per cent of the total activity in the collectors was in the solid particulate. The average amount of leaching of activity into the rain water was approximately 50 per cent. No correlation could be found between location of the collector and the amount of leaching.

Approximately 0.1 g of particulate that was collected in the dry state was allowed to leach in a surplus (500 cu cm) of distilled water for over one week to see whether there was a cor-

UNCLASSIFIED 39 UNCLASSIFIED  
~~SECRET~~ — SECURITY INFORMATION

UNCLASSIFIED  
SECRET

relation between the ratio of activities and the ratio of mass before and after leaching. The ratio of the weight of solid remaining after leaching to the original weight was 48 per cent, whereas the ratio of the activity in the leached solid to the total activity of the solid before leaching was 54 per cent.

Table 4.2 — X-RAY-DIFFRACTION ANALYSIS OF RADIOACTIVE  
PARTICLES REMOVED FROM THE DIFFERENTIAL  
FALL-OUT COLLECTORS

Station	Compounds present	Compounds probably present	Remarks
Janet	CaCO <sub>3</sub> (calcite) CaCO <sub>3</sub> (artificial calcite) Ca(OH) <sub>2</sub> (Portlandite) CaCO <sub>3</sub> (aragonite)		
Wilma		CaCO <sub>3</sub> (aragonite)	Amount of sample less than 1 mg; identity of compound not certain
540.16	CaCO <sub>3</sub> (calcite) CaCO <sub>3</sub> (artificial calcite)	Unknown compounds of large lattice spacings	See Station 540.18 remarks
540.18	CaCO <sub>3</sub> (calcite) CaCO <sub>3</sub> (artificial calcite) Ca(OH) <sub>2</sub> (Portlandite) CaCO <sub>3</sub> (aragonite) NaCl (halite)	Unknown compounds of large lattice spacings	The unknown compounds of large lattice spacings are not all the same; preliminary determinations have shown them to be the less common compounds; further research is needed to determine their nature
540.13	Ca(OH) <sub>2</sub> (Portlandite) CaCO <sub>3</sub> (calcite) NaCl (halite) CaCO <sub>3</sub> (artificial calcite)		
540.14	CaCO <sub>3</sub> (calcite) CaCO <sub>3</sub> (artificial calcite) MgO (periclase)	Unknown compounds of large lattice spacings	See Station 540.18 remarks
540.09		CaCO <sub>3</sub> (aragonite)	Amount of sample less than 1 mg; identity of compound not certain

The liquid from the total collector located at Station 540.18 was analyzed to determine the percentage of activity from ions and that from colloids. This analysis was done by ultrafiltration at 38 atm through a cellophane dialyzing membrane with a pore size in the range of 12 to 40 A. It was found that 71 ± 3 per cent of the activity was associated with the ionic species and 29 ± 4 per cent with the colloids. Since this liquid sample had been previously filtered through Whatman No. 30 paper, some of the colloids remained with the particulate caught by the filter.

RESTRICTED DATA — SECRET — UNCLASSIFIED  
UNCLASSIFIED

UNCLASSIFIED

#### 4.2.4 Decay of Activity

Figure 4.7 shows the gross decay of a particle taken from a lagoon station during the interval D+15 to D+90 day. The slope of this curve varies from -1.9 at D+15 day to -1.0 at D+70 day. An examination of the gamma decay from H+2 hr, as obtained by Project 5.3, indicated a slope of approximately -1.2.

#### 4.2 PHYSICAL DISTRIBUTION OF FALL-OUT

The mass measurements for determining the physical distribution of particulate were made from the material in the total collectors. It was assumed that the amount of activity in the rain water from leaching of the particulate was proportional to the amount of solid dissolved. This assumption allows for an error of at least 10 per cent. Also, an unknown amount of particulate did not get into the collecting bottles because of its tendency to adhere to any moist surface such as the collecting funnel. Therefore, as a check, the material collected in the rain-gage buckets was also used to establish a mass distribution. The values recorded in Fig. 4.8 represent the greatest mass, corrected to grams per square foot, that was collected in either the total collector or the rain gage. These values are not absolute but represent the minimum amount of fall-out occurring at any one station.

*Variation of Mass with Cross-wind Distance.* The quantity of fall-out, cross wind, varied from some value over 20 g/sq ft at 4 miles to zero at approximately 15 miles. There is no evidence of an exponential mass distribution between 4 and 15 miles (Fig. 4.9); however, previous test data<sup>1,2</sup> show evidence of an exponential distribution.

#### 4.4 PARTICLE-SIZE DISTRIBUTION, RADIOACTIVE

An examination of the particle-size distribution was undertaken to investigate and further document the existing theories of the fall-out mechanism. It was not the purpose of this project to obtain detailed data on this subject but simply to get a gross picture of the existence or nonexistence of particles within various size ranges. This information, together with a knowledge of the time of arrival of the particulate, permitted further work (see Chap. 6) on the determination of the fall-out mechanism.

##### 4.4.1 Particle-size Distribution as a Function of Time

There was some indication of fractionation of particle size with respect to time of arrival. Figure 4.10 shows the time distribution of particulate at two cross-wind stations, one 8 miles distant and the other 15 miles. In both cases the fall-out arriving at later times did not contain particles as large as were found at early times.

The frequency of particles in the range 0 to 25  $\mu$  is not known; however, in all cases particles within this range were identified. In all cases particles from less than 25  $\mu$  to at least 300  $\mu$  and in some cases as large as 5000  $\mu$  were found to have arrived at the same time.

##### 4.4.2 Particle-size Distribution as a Function of Distance

There was no indication of fractionation of particle size with cross-wind distance. The distribution covered approximately the same range at all stations from 5 to 15 miles (Table 4.3).

#### 4.5 TIME OF ARRIVAL OF PARTICULATE

Four cross-wind stations within the fall-out area were selected as having flawless records of the arrival of fall-out with time. These stations were located at 5, 10, and 15 miles, as

UNCLASSIFIED

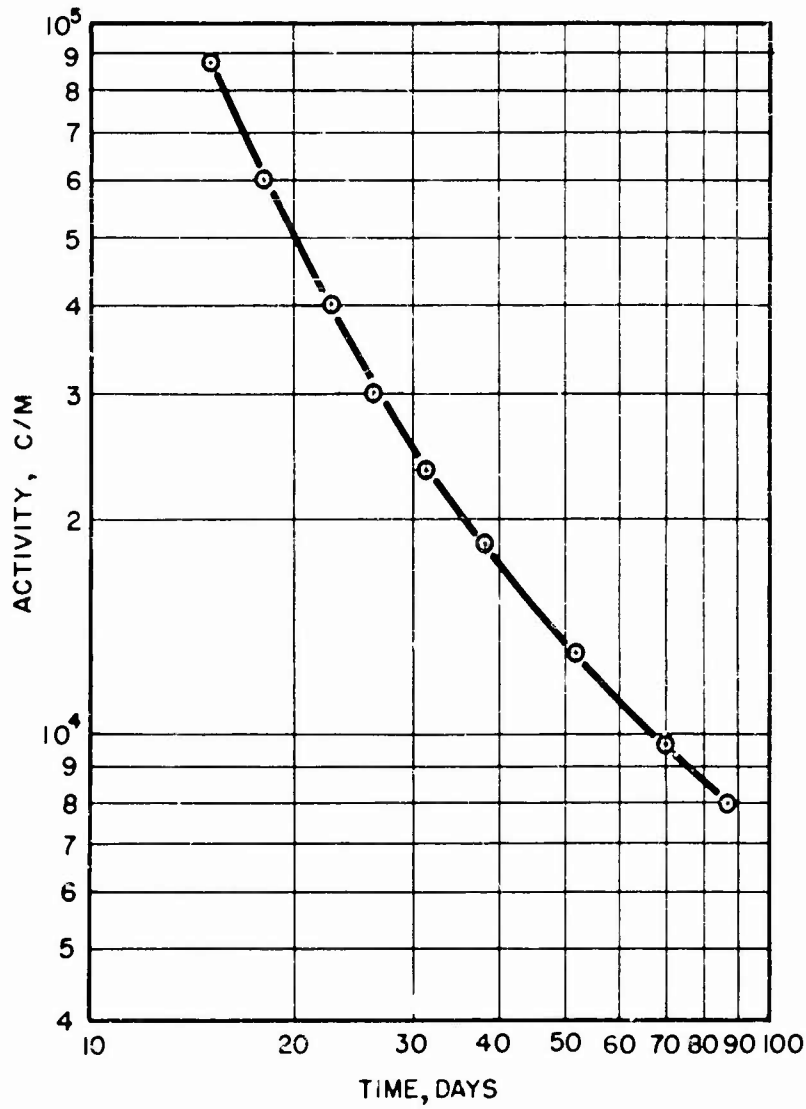

Fig. 4.7—Beta and gamma decay curve from 15 to 90 days after shot.

**UNCLASSIFIED**

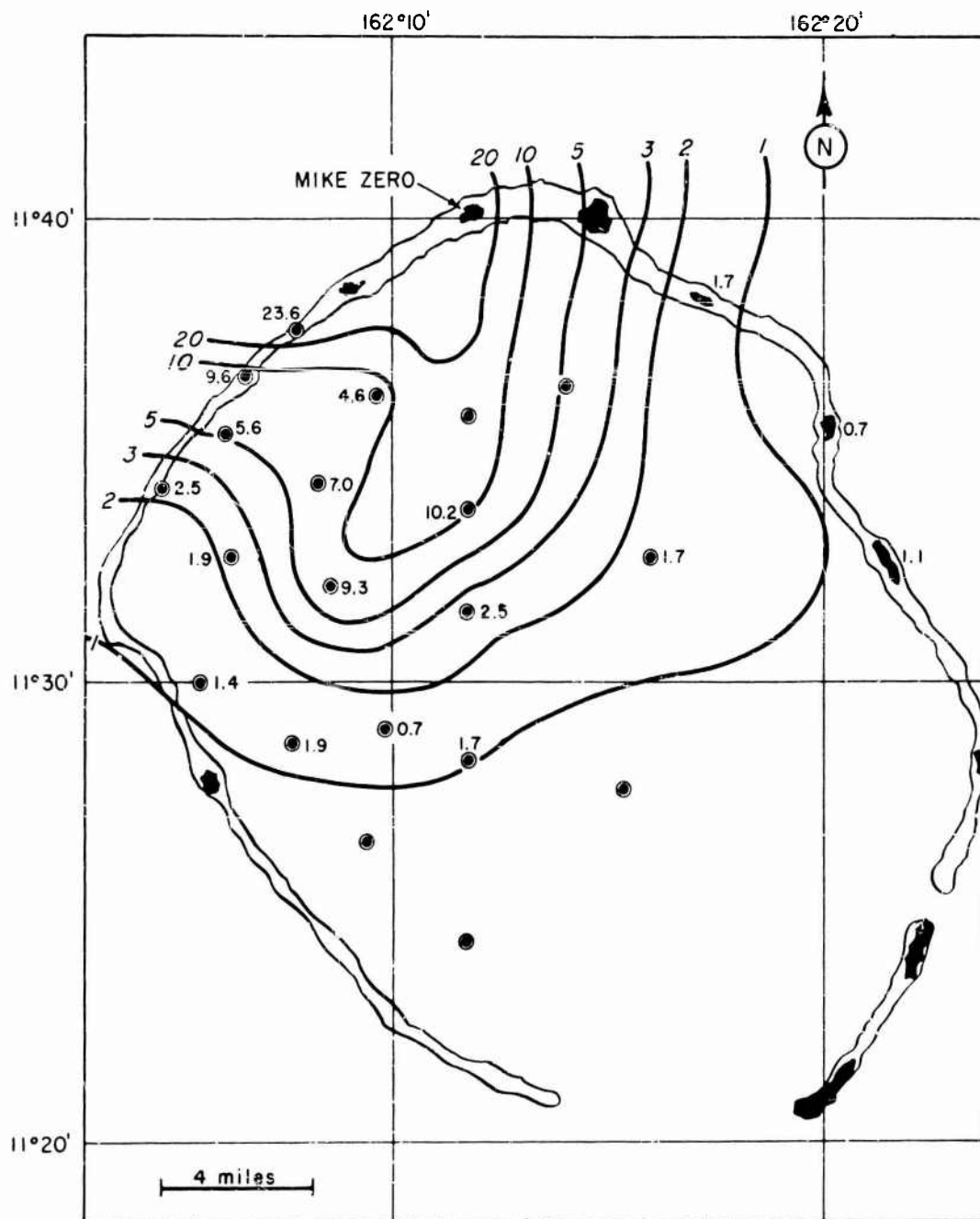

Fig. 4.8—Mass distribution of fall-out (g/sq ft).

~~SECRET~~

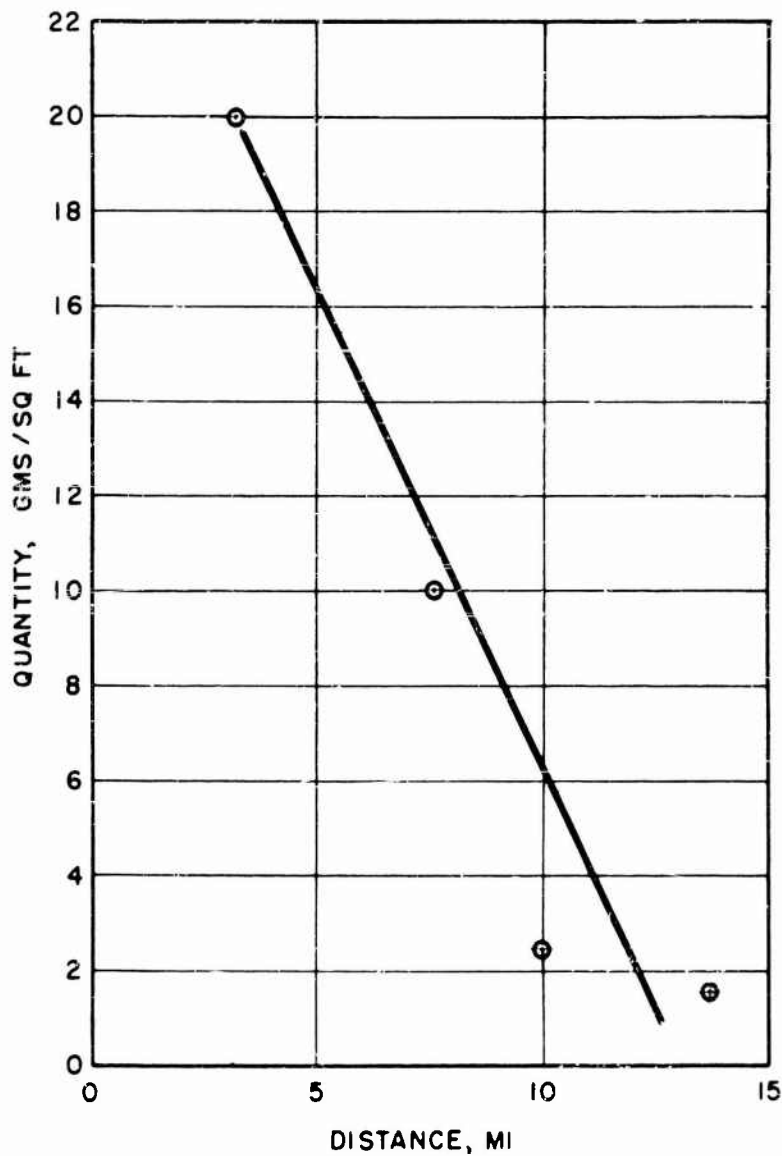

Fig. 4.9—Variation of cross-wind fall-out with distance from ground zero.

~~UNCLASSIFIED~~

44

~~SECRET~~ — SECURITY INFORMATION

~~UNCLASSIFIED~~

UNCLASSIFIED

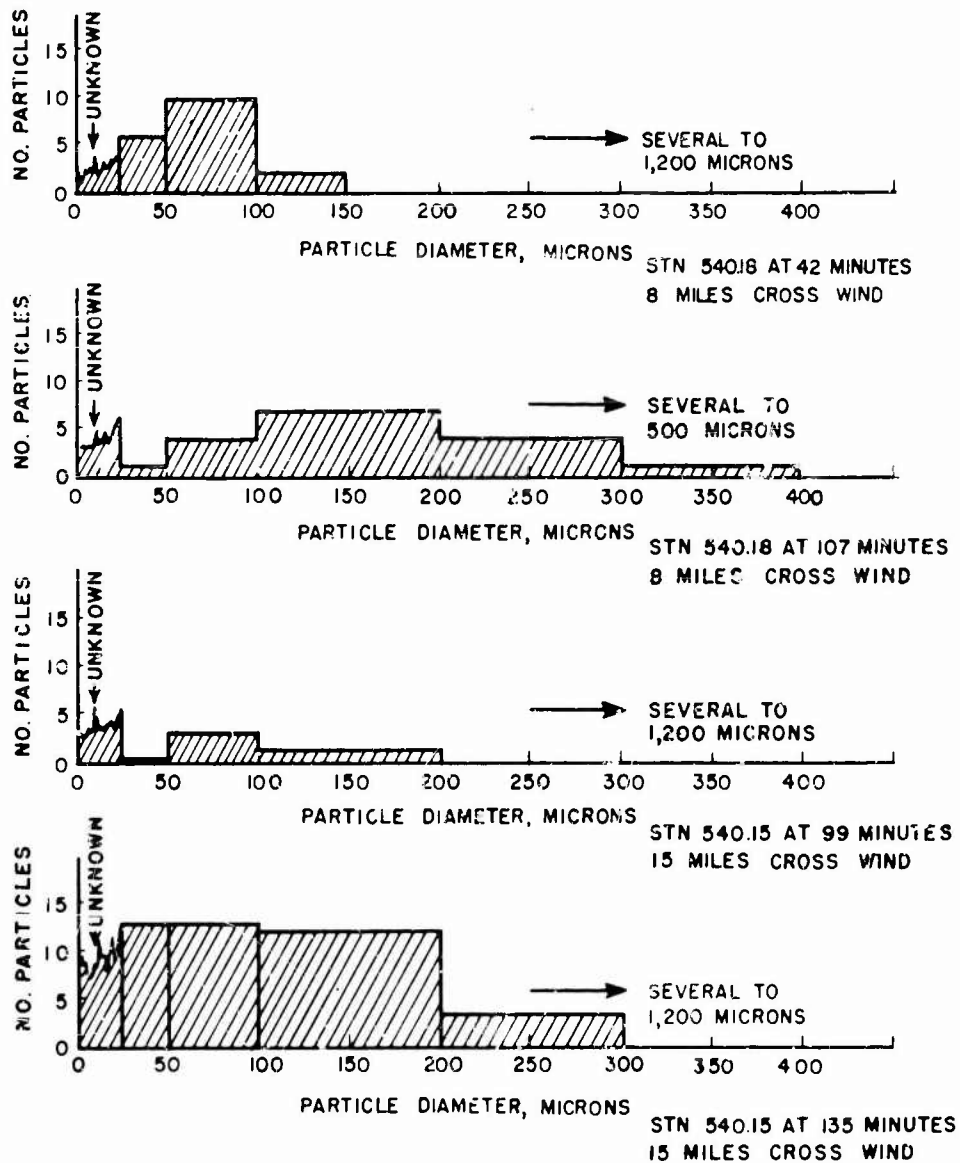

Fig. 4.10—Size distribution of radioactive particles as a function of time and distance.

RESTRICTED DATA - SECRET - SECURITY INFORMATION

~~UNCLASSIFIED~~  
SECRET

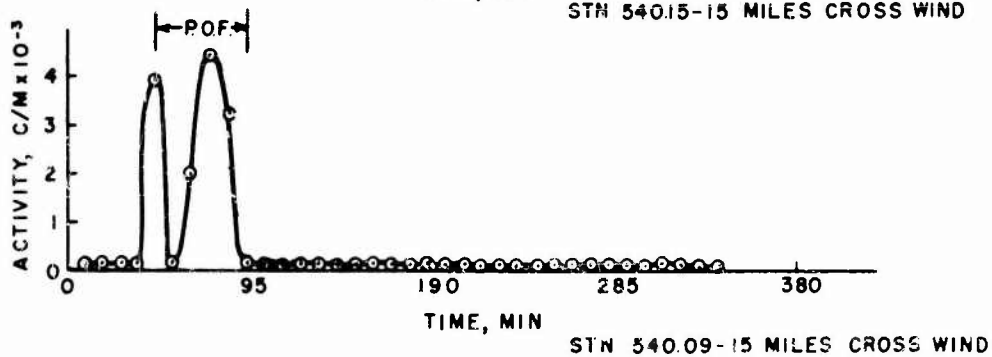
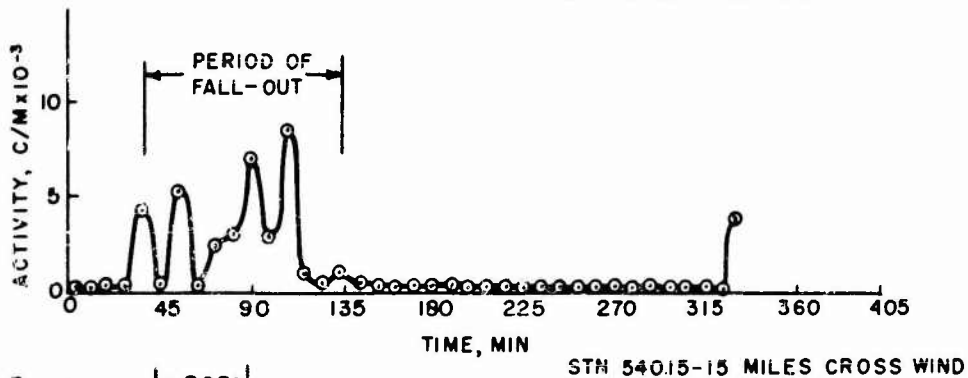
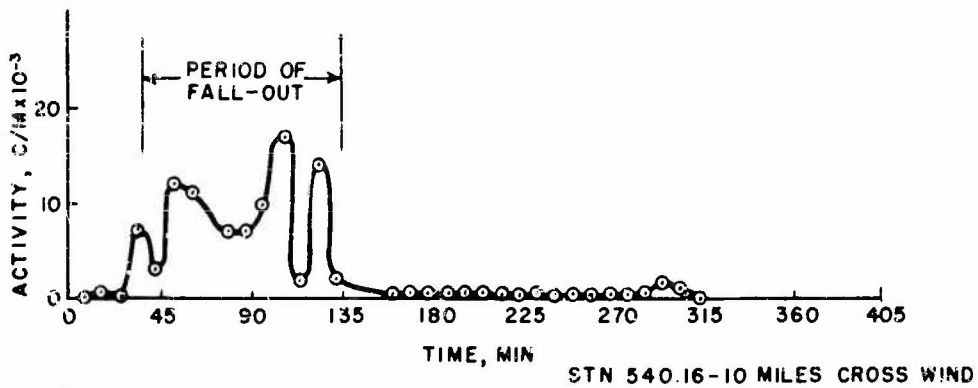
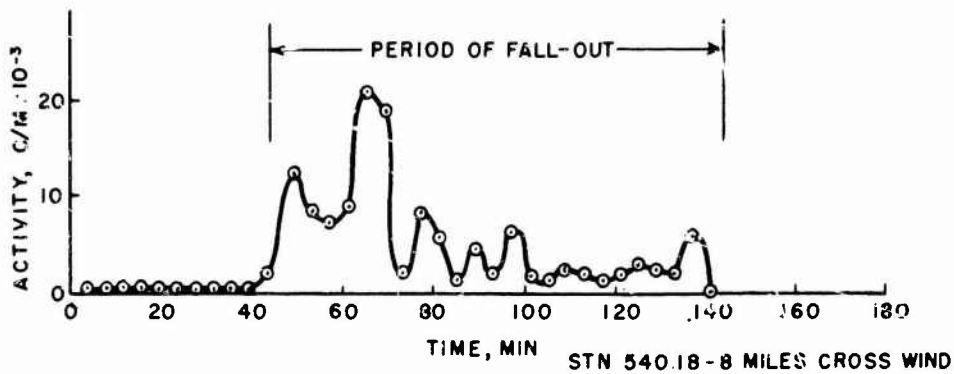

Fig. 4.11—Periods of primary fall-out at different stations.

~~UNCLASSIFIED~~

**UNCLASSIFIED**  
RESTRICTED DATA - SECURITY INFORMATION

shown in Fig. 4.11. Stations 540.15 and 540.09 were both located at 15 miles, but at different azimuths from ground zero (see Fig. 2.1 for location).

#### 4.5.1 Arrival of Fall-out

It is most interesting to note that the cross-wind arrival time was completely independent of distance from ground zero. At the four stations from 8 to 15 miles, the fall-out began at +40 to +45 min. This suggests a delivery mechanism independent of winds (Chap. 6).

Table 4.3 — SIZE DISTRIBUTION OF RADIOACTIVE FALL-OUT PARTICLES

Station	Distance cross wind, miles	Period of fall-out	Size distribution, $\mu$					Remarks
			25	50	100	200	300	
			to 50	to 100	to 200	to 300	to 400	
540.20	5.0	Early	4	8	14	5	7	Several particles to 5000 $\mu$
540.18	8.0	Early	6	10	2			Several particles to 1200 $\mu$
540.15	8.0	Middle	1	1	7	4	1	Several particles to 500 $\mu$
540.17	10.0	Middle	1	2	10	1		Several particles to 1000 $\mu$
540.16	10.0	Early	9	23	1	3		
540.15	15.0	Middle	0	2	1			Several particles to 1200 $\mu$
540.15	15.0	Late	13	13	12	3		Several particles to 1200 $\mu$

#### 4.5.2 Duration of Fall-out

The four stations fixed the duration of fall-out at something less than 2 hr, with three of these stations experiencing exactly the same duration. Station 540.09, to the east of 540.15, shows the cessation of the fall-out to be at 0 + 95 min, a somewhat earlier time than the time of 0 + 144 min experienced by the other three stations.

#### 4.5.3 Distribution of Activity with Time

Figure 4.11 shows the randomness of the time distribution of fall-out within the period in which it occurred. All the stations experienced several maxima and minima. These peaks and valleys show no correlation between time and distance. Since the samples were collected over limited areas, the levels of activity shown in Fig. 4.11 are not too representative.

#### REFERENCES

1. I. G. Poppoff, Fall-out Particle Studies, Jangle Project 2.5a-2 Report, WT-395; also in Particle Studies, WT-371.
2. U. S. Naval Radiological Defense Laboratory Report on High Explosive Model Studies (in preparation).

**UNCLASSIFIED** RESTRICTED DATA - SECURITY INFORMATION **UNCLASSIFIED**

**UNCLASSIFIED**

## CHAPTER 5

### SECONDARY FALL-OUT

For many days following a detonation, radioactive debris falls out over the surface of the earth. Previous tests have shown no reason for considering this secondary fall-out to be of military significance; a certain amount of documentation in this area is necessary, however, as a check and to provide information on upper air movements.

#### 5.1 DISTRIBUTION OF SECONDARY FALL-OUT

From 2 to 3 days after the detonation, secondary fall-out arrived over an extensive area of the Pacific around Eniwetok Atoll. This fall-out was measured on Majuro, Kwajalein, Bikini, Kusaie, Eniwetok, and Ponape, as well as on task force ships and the free-floating stations. Johnston Island recorded no measurable fall-out, but Guam, which was not instrumented, is believed to have received a small amount. Figure 5.1 shows the concentration of particulate received at Bikini Atoll on 4 November 1952. This is typical of the particle density received at all the outer islands.

#### 5.2 LEVELS OF RADIOACTIVITY

None of the stations at which secondary fall-out was collected reported a gamma dose rate over 10 mr/hr. These dose rates were determined with gamma-survey instruments. In many instances the level of radiation at the stations was so low that the instruments failed to detect the presence of any fall-out. Detection of fall-out at these stations was made by thin-window counting with laboratory beta and gamma instruments.

#### 5.3 PERIOD OF SECONDARY FALL-OUT

The secondary fall-out over the area within 600 miles of Eniwetok Atoll lasted for several days. Figure 5.2 shows the distribution of activity with time for the outer islands. There is a trend that indicates the easternmost islands experienced fall-out first, at M+2 day. The secondary fall-out drifted to the west and south, arriving at Ponape, the westernmost island, on M+5 day.

#### 5.4 PARTICLE SIZE OF SECONDARY FALL-OUT

The particle size of the secondary fall-out was investigated by observation of the radioactive particulate collected on several of the outer islands. In no case was it larger than 25  $\mu$ . No determination was attempted on the distribution of particle size.

**UNCLASSIFIED** ~~RESTRICTED DATA - SECRET~~ ~~SECURITY INFORMATION~~ **UNCLASSIFIED**

**UNCLASSIFIED**

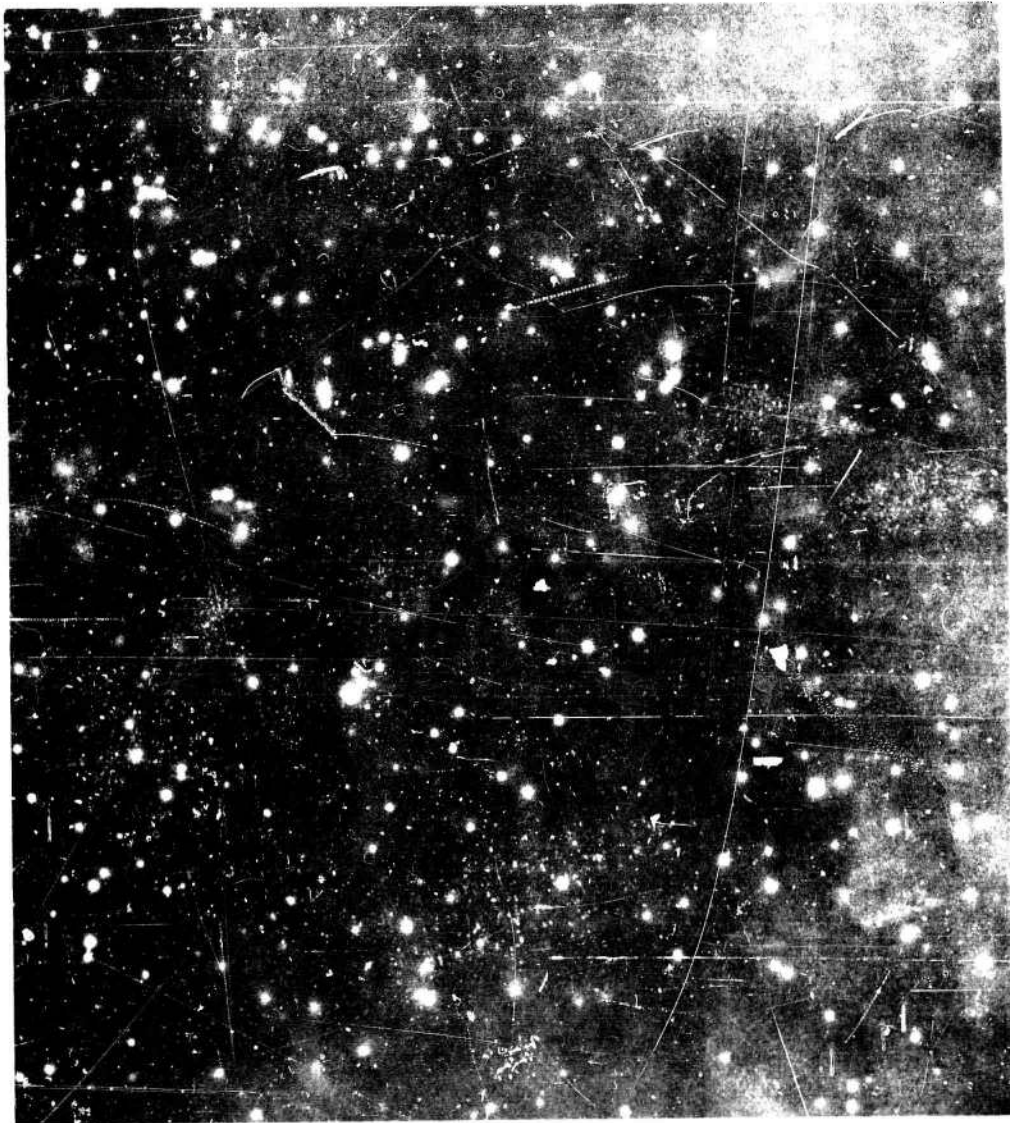

Fig. 5.1—Radioautograph of secondary fall-out particles.

**UNCLASSIFIED** <sup>49</sup> **UNCLASSIFIED**  
RESTRICTED DATA - SECRET SECURITY INFORMATION

UNCLASSIFIED

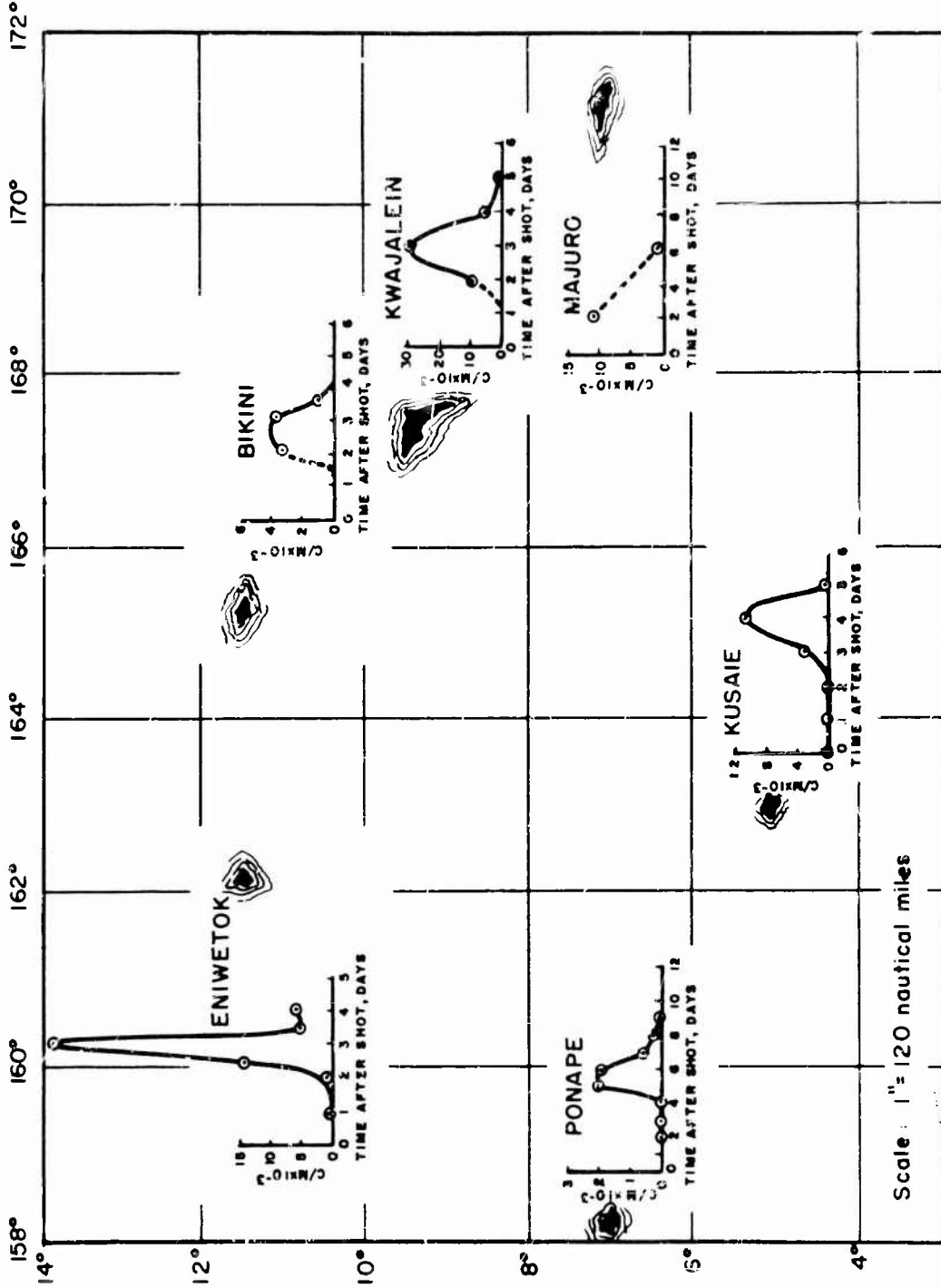

Fig. 5.2—Periods of secondary fall-out at the outer island stations.

UNCLASSIFIED 50 UNCLASSIFIED

~~SECRET~~  
**UNCLASSIFIED**

## CHAPTER 6

# METEOROLOGICAL CONSIDERATIONS AND FORECASTS OF FALL-OUT

Knowledge of the mechanism of the fall-out phenomenon is necessary as a first step in the development of forecasting techniques that will satisfactorily define the gamma field created by the residual radioactive debris from a nuclear detonation. Fall-out gamma fields of military significance are known to develop with surface and underground or underwater nuclear explosions, and the problem of fixing both the location and extent of the resultant radiation field is paramount for either offensive or defensive operations. Solution of this problem requires knowledge of the shot location, an estimate of the resulting cloud height, and the wind speed and direction to an elevation equal to the height of the explosion cloud.

### 6.1 THEORIES OF FALL-OUT MECHANISM

J. O. Hirschfelder's analysis<sup>1</sup> satisfactorily explains the mechanism of fall-out, except for the area immediately surrounding ground zero at Operation Ivy.

The theory developed by Charles E. Adams<sup>2</sup> accounts for the phenomenology of the fall-out in the area in the immediate vicinity of ground zero.

It is believed that these theories in their respective areas accounted for the fall-out phenomena accurately at Operation Ivy.

### 6.2 PRIMARY FALL-OUT

No data were collected downwind from ground zero. Figure 6.1 represents the downwind fall-out area as defined by the Hirschfelder analysis.

The cross-wind data showing the arrival time to be independent of distance can be satisfactorily explained by the vertical-circulation theory as explained by Adams in the Greenhouse fall-out studies. If a cloud chimney 5 miles in diameter is assumed to contain rising air currents, there is reason to believe descending currents exist around this upward convection column out to a distance equal to several column diameters. This vertical circulation is analogous to the circulation around a thunderstorm. A subsidence of this type would deposit particulate of heterogeneous mixture out to approximately 15 miles, and the time of deposition would be independent of distance.

Therefore the primary fall-out pattern is believed to have developed by two separate and distinct mechanisms: first, a subsidence extending out to several cloud diameters and, second, a downwind pattern determined by particle settling rates and the wind profile. This downwind pattern is based on the assumption that the particulate source is the cloud chimney from the

51  
~~SECRET~~  
**UNCLASSIFIED** **UNCLASSIFIED**

UNCLASSIFIED

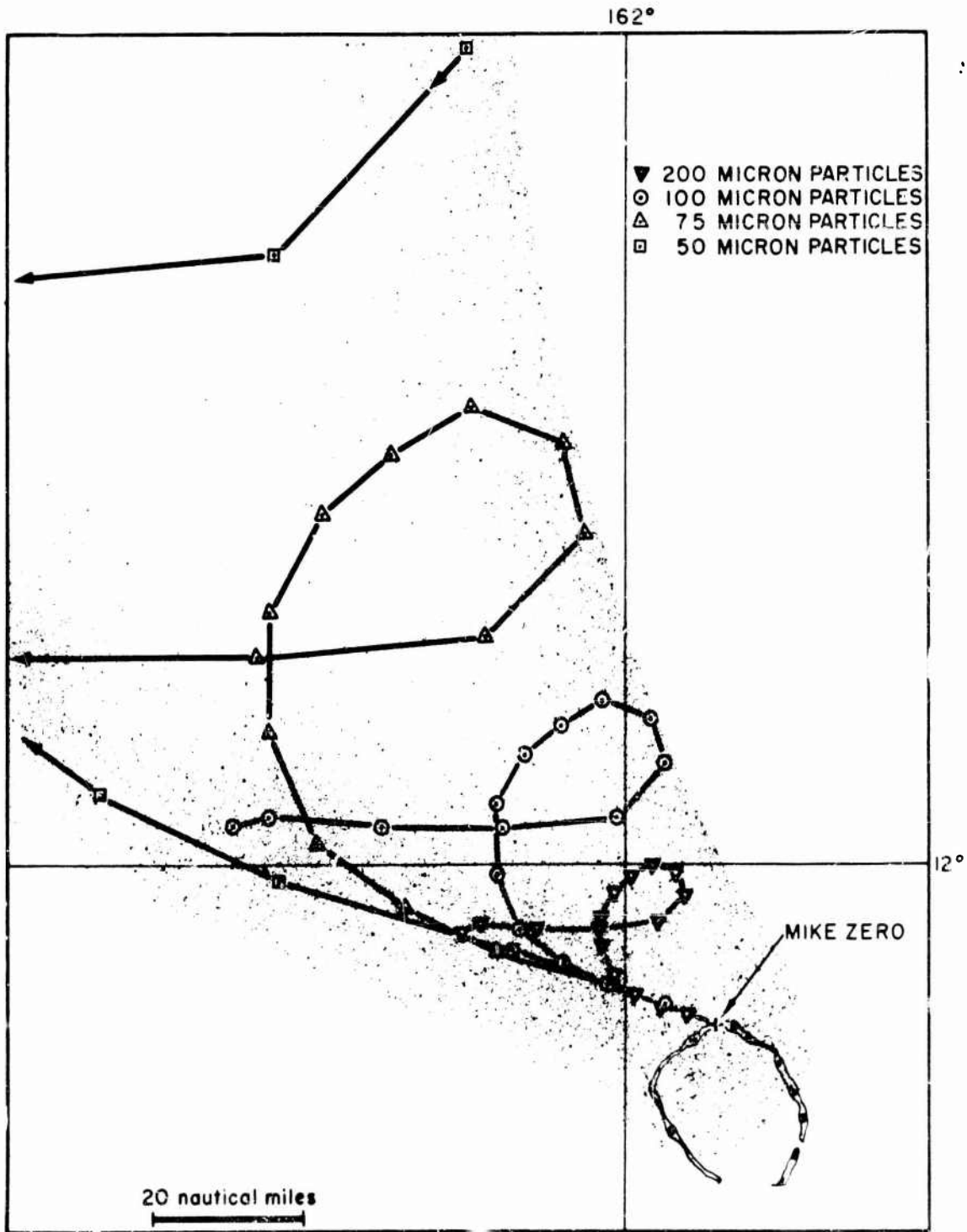

Fig. 8.1—Predicted area of primary fall-out.

**UNCLASSIFIED**

surface to the cloud's maximum elevation, with a heterogeneous particle-size mixture existing throughout. The points of arrival of particle sizes from all elevations define the downwind pattern with respect to both area and time of arrival.

### 6.3 SECONDARY FALL-OUT

The winds in the Marshall Islands area above 90,000 ft are predominantly from the west at the time of the year of Operation Ivy.<sup>3</sup> The cloud from Mike shot rose to a height greater than 100,000 ft and was observed to move to the east. The few winds above 90,000 ft observed during the operation by the task force Weather Central were from the west.

The arrival time of the secondary fall-out can be satisfactorily explained by assuming that the particulate originated in the uppermost portion of the cloud, carried eastward by the stratospheric winds. Since the particulate settled into the troposphere somewhere east of the Marshall Islands area, an examination of the troposphere wind pattern during the days following the detonation showed that the particulate would be carried back westward and deposited as secondary fall-out in the area investigated.

### 6.4 THE EFFECT OF VERTICAL MIXING

The arrival time of small particulate at distances beyond the area of subsidence has defied explanation by particle settling rates. This failure is especially evident when considering arrival times of secondary fall-out. It is suggested that for particles whose diameter and density establish slow settling rates the effect of vertical mixing in the atmosphere becomes the primary mechanism determining their deposition.

### REFERENCES

1. Los Alamos Scientific Laboratory, "The Effects of Atomic Weapons," Appendix F, U. S. Government Printing Office, Washington, 1950.
2. Charles E. Adams, Fall-out Phenomenology, Greenhouse Report, Annex 6.4, WT-4, August 1951.
3. C. E. Palmer, The Central Pacific Project, First Report, Institute of Geophysics, October 1951.

**UNCLASSIFIED** 53 **UNCLASSIFIED**  
RESTRICTED DATA - SECRET - SECURITY INFORMATION

**UNCLASSIFIED**

## CHAPTER 7

### SUMMARY

Prediction of the downwind area of primary fall-out with a high degree of confidence early enough to establish a selective station array to cover the area cannot be satisfactorily accomplished. The limited climatological data available for the Marshall Islands indicate the most probable direction of the winds aloft during the fall and winter months to be from the east for heights of approximately 20,000 ft and from the west for heights between 20,000 and 100,000 ft. However, the wind profile at shot time indicated that the primary fall-out following Mike shot was deposited to the northwest of Eniwetok Atoll. It is noteworthy that during the two weeks prior to shot time, the daily variation in the wind profile was of such magnitude that a 24-hr forecast of the fall-out area would have been in error in the majority of cases. However, if the winds aloft are known at the time of detonation, it is possible to predict quite accurately the distribution of ground contamination resulting from radioactive fall-out.

Observation of the documentary photography taken of Mike shot, Operation Ivy, indicated no evidence of a base surge following the detonation. Although the major portion of this film did not record surface phenomena, those portions documenting the surface of the lagoon after the event do not show a base surge.

The fall-out particulate, being primarily compounds of calcium, was peculiar to a coral atoll. The main contribution to the radiation field was the fission product mixture trapped within these particulates. The particle density was between 1 and 3 g/cu cm in the majority of cases and similar to that of many soils. Although there was not a great quantity of fall-out at any location, the individual particles were very active, some reading as high as 300 m<sub>r</sub>/hr of beta-gamma radiation 48 hr after shot time. The activity was easily leached from the particulate by the action of rain water. The particle reaction with the sulfate ions in sea water caused them to become hollow and to adhere to any surface they touched. This behavior is probably the most significant observation of the effect of the environment on the particles.

#### 7.1 CONCLUSIONS

In summarizing the work done on this project, it is convenient to state the conclusions as they specifically apply to either the primary or secondary fall-out.

##### 7.1.1 Primary Fall-out

The gamma-radiation field at the cessation of the primary fall-out varied from about 800 r/hr at 2 hr and 3 miles distance to 0 r/hr at a cross-wind distance of approximately 15 miles.

There was no residual radiation field over the open water of the lagoon. Evidently the radioactive particulate immediately settled to the bottom.

The gamma decay curve for the radioactive fall-out has a slope of approximately -1.2.

~~RESTRICTED DATA - SECRET~~ **UNCLASSIFIED**

**UNCLASSIFIED**  
**SECRET**

The fall-out was solid particulate made up of calcium hydroxide with a very thin layer of calcium carbonate on the outer surface. The fission products were trapped within the particulate.

Those particles that arrived in such an environment as sea-washed decking were slowly dissolved, with a resulting reprecipitation of the calcium ion by the sulfate ion which exists in comparatively high concentration in sea water. As a result of this phenomenon, many hollow particles formed and firmly adhered to all surfaces they touched.

The fission products readily leached from the particulate exposed to rain water. The leached activity was both ionic species and colloids.

The quantity of primary fall-out in the cross-wind direction varied from some value over 20 g/sq ft at 4 miles to 0 g/sq ft at 15 miles.

The particle diameters of the radioactive fall-out varied from less than 10  $\mu$  to greater than 5000  $\mu$ .

There was no particle-size fractionation with cross-wind distance and only meager evidence of any with time.

The cross-wind fall-out arrival time was entirely independent of distance from ground zero; duration of fall-out was approximately 1 to 2 hr.

There was a random distribution of activity with time at all stations in the cross-wind radiation field.

#### 7.1.2 Secondary Fall-out

Secondary fall-out arrived over an extensive area of the Pacific around Eniwetok Atoll.

The period of secondary fall-out was several days at any one location, arriving from 2 to 5 days after the detonation.

None of the secondary fall-out was of military significance since a gamma dose rate of less than 10 mr/hr was noted at all collecting stations.

In no case was any of the secondary fall-out particulate over 25  $\mu$  in diameter.

The secondary fall-out arrived from an initial height greater than 80,000 ft.

#### 7.2 RECOMMENDATIONS

Experience gained during the work on this project makes possible certain suggestions for consideration in the planning of future operations. The inability to predict the area of primary fall-out well in advance of shot time can be presumed to be definitely established. Consequently it is recommended that a 360° coverage of collecting stations be provided in future tests.

Furthermore the use of free-floating stations can be considered practical and highly desirable if a method for their positive location is provided. Whatever methods that are devised for locating the free-floating stations must not interfere with the task force security search patrol. Therefore it is recommended that a lightweight coded signaling device such as the British Ultra Air Sea Rescue beacon be installed on each of the free-floating stations.

**UNCLASSIFIED** **SECRET** **UNCLASSIFIED**  
**RESTRICTED DATA** **SECRET** **RESTRICTED DATA**

**UNCLASSIFIED**

## APPENDIX A

### EXPERIMENTAL PROCEDURE

#### A.1 ANALYSIS OF THE TOTAL-COLLECTOR SAMPLES

Since the total collectors were open to the atmosphere before and after the fall-out period, the samples recovered from them were mixed with rain water. Consequently some of the fission product leached from the particulate to the rain water.

When each sample was recovered, 1 pt of distilled water was poured through the total collectors. This flushing washed most of the particulate from the funnel and tubing into the collecting bottle. The samples were treated as follows:

1. Samples were filtered with Whatman No. 30 filter paper.
2. The filter paper containing the solid particulate matter was ignited, and the residue was weighed to the nearest 0.1 mg on a Sartorius analytical balance.
3. The weighed portion of the solid sample was mounted on an aluminum holder. This sample was chosen small enough to decrease the effects of self-absorption. The sample was counted with a proportional counter, where the first, second, or fourth shelf was used, depending on the activity of the sample. All values were corrected for the efficiency of the counter; no absorbers were used. Since no corrections for back-scattering, self-absorption, or absorption were made, only relative counts were obtained.
4. The total and specific activities of the solid samples were determined.
5. An aliquot of the filtrate was mounted on an aluminum holder, dried under a heat lamp, and counted as described in 3.
6. The total volume of the filtrate was measured for each sample.
7. The total and specific activities of the liquid were obtained.

#### A.2 ANALYSIS OF THE GUM-PAPER SAMPLES

In some cases, upon recovery of the samples, field readings of the gamma dose rate were taken. At the laboratory the 12- by 12-in. sheets of gum paper were counted, relative to each other, to determine the time of arrival of the secondary fall-out. This counting was done by folding each sheet into a 4- by 9-in. rectangle which was then mounted on an aluminum plate and counted with a proportional counter which had a 4- by 9-in. window. No compensation was attempted for the counting error introduced by absorption because only the times at which the activity began and ended were desired.

#### A.3 ANALYSIS OF THE DIFFERENTIAL FALL-OUT SAMPLES

These samples were collected in lucite compartments and delivered to the laboratory in an undisturbed state. Each collector had 72 compartments, every other one of which contained

**UNCLASSIFIED** **RESTRICTED DATA** **SECRET** **UNCLASSIFIED** **SECURITY INFORMATION**

**UNCLASSIFIED**

glass microscope slide covered with a very thin film of silicone grease. The following work was done on these samples:

1. The total activity of each compartment not containing a microscope slide was measured by mounting the fall-out particles in a steel planchet and counting with a proportional counter. Only relative values were obtained by this method.
2. The particulate on the glass slides was analyzed for particle-size determination. Radioautographs were made by using an Eastman NTB nuclear-emulsion overlay. The emulsion was developed in place, and the radioactive particles were located by viewing through the darkened areas on the emulsion. Measurements were made to determine only the presence or absence of particles within certain size ranges. This work was done with an optical microscope having a magnification of 23.25. Similar work was conducted on the secondary fall-out particles.

#### A.4 CHEMICAL ANALYSIS OF FALL-OUT SAMPLES

Certain selected samples of the fall-out particles were subjected to emission spectrographic and X-ray-diffraction analyses to determine their chemical characteristics. Extensive petrographic analysis of the particulate was made, and its results will be published later.

#### A.5 ANALYSIS OF THE LEACHED ACTIVITY

The activity that leached into the rain water in the total collectors was analyzed for the relative percentage of ionic or colloidal species. This analysis was accomplished by ultra-filtration at 38 atm through a cellophane dialyzing membrane and by counting the separations.

#### A.6 RADIOCHEMICAL ANALYSIS OF SELECTED SAMPLES

Samples with a high order of radioactivity were subjected to a limited radiochemical analysis. This work is currently done by the usual radiochemical techniques.

#### A.7 ION-EXCHANGE-COLLECTOR ANALYSIS

A mixed-bed resin (Amberlite MB-1) and a cation exchanger (Dowex-50) were the two types of ion-exchange resins used as collecting agents. Discussion of the ion-exchange-collector analysis will be published later.

**UNCLASSIFIED**

RESTRICTED DATA - SECRET

**UNCLASSIFIED**

~~UNCLASSIFIED~~ SECRET ~~UNCLASSIFIED~~

## APPENDIX B

### TABULATED DATA

#### B.1 TOTAL-COLLECTOR AND RAIN-GAGE DATA

Tables B.1, B.2, and B.3 list the amount and activity of fall-out collected in the total collectors and the rain-gage buckets. Values of activity have been corrected to a common date of 21 November 1952, and both weight of fall-out and activity are expressed in units per square foot. To obtain the total weight of solids that arrived at each station, the leached activity in the rain water was converted to an equivalent weight of solid, and this value was added to the weight of solid collected. This conversion was accomplished by assuming that the quantity of material leached was proportional to the amount of activity leached.

#### B.2 SECONDARY FALL-OUT DATA

Data listed in Table B.4 represent the activity collected on the gummed-paper collectors located at the weather islands and aboard the task force ships. Each collector consisted of 2 sq ft of Kum-Kleen gummed paper, and exposures were made for either 12- or 24-hr periods. All counting data are corrected to 21 November 1952.

#### B.3 SUMMARY OF DATA COLLECTED ON THE FREE-FLOATING SEA STATIONS

The free-floating sea stations were not in the area of primary fall-out, and those data collected represent the activity from secondary fall-out only. Recovery of the sea stations was made while the secondary fall-out was arriving, so the data are of little value. Each station was equipped with a total collector as well as 1 sq ft of Kum-Kleen gummed paper. All counting data were corrected to 21 November 1952 and are listed in Table B.5.

~~UNCLASSIFIED~~ 59 ~~UNCLASSIFIED~~  
~~SECRET~~ ~~SECRET~~ ~~UNCLASSIFIED~~

**UNCLASSIFIED**  
**SECRET**

Table B.1 — WEIGHT AND ACTIVITY OF SOLID FRACTION  
OF COLLECTED MATERIAL

Station	Distance from ground zero, ft	Weight residue, g	Specific activity, c/m/g	Total activity, c/m	Gross activity on unit area, c/m/sq ft
Total Collectors					
540.02	56,800	0.105	$1.08 \times 10^8$	$0.11 \times 10^8$	$0.576 \times 10^8$
540.05	39,600	0.063	$10.50 \times 10^8$	$0.66 \times 10^8$	$3.36 \times 10^8$
540.06	52,800	0.059	$6.46 \times 10^8$	$0.03 \times 10^8$	$0.14 \times 10^8$
540.07	71,280	0.143	$0.19 \times 10^8$	$0.03 \times 10^8$	$0.14 \times 10^8$
540.09	68,640	0.029	$10.25 \times 10^8$	$0.40 \times 10^8$	$2.04 \times 10^8$
540.11	52,800	0.070	$0.22 \times 10^8$	$0.02 \times 10^8$	$0.08 \times 10^8$
540.12	73,920	0.027	$3.48 \times 10^8$	$0.10 \times 10^8$	$0.48 \times 10^8$
540.13	27,050	0.633	$14.50 \times 10^8$	$9.18 \times 10^8$	$46.7 \times 10^8$
540.14	39,600	0.121	$8.47 \times 10^8$	$1.02 \times 10^8$	$5.2 \times 10^8$
540.15	72,000	0.090	$1.12 \times 10^8$	$0.10 \times 10^8$	$0.52 \times 10^8$
540.16	55,400	0.139	$3.73 \times 10^8$	$0.51 \times 10^8$	$2.65 \times 10^8$
540.18	44,880	0.806	$14.16 \times 10^8$	$11.41 \times 10^8$	$58.1 \times 10^8$
540.20	~26,000	0.683	$3.013 \times 10^8$	$0.01 \times 10^8$	$0.05 \times 10^8$
Nancy	33,800	0.283	$9.36 \times 10^8$	$2.65 \times 10^8$	$13.5 \times 10^8$
Wilma	57,180	0.046	$19.22 \times 10^8$	$0.88 \times 10^8$	$4.50 \times 10^8$
Yvonne	75,520	0.228	$6.54 \times 10^8$	$1.49 \times 10^8$	$7.60 \times 10^8$
Elmer	115,060	0.002	$0.10 \times 10^8$	$2.00 \times 10^4$	$10.2 \times 10^4$
Fred	124,580	0.002	$0.097 \times 10^8$	$2.00 \times 10^4$	$10.2 \times 10^4$
Bruce	102,670	0.002	$0.040 \times 10^8$	$0.80 \times 10^4$	$4.0 \times 10^4$
Rain-gage Buckets					
540.02	52,800	0.507	$3.93 \times 10^8$	$1.99 \times 10^8$	$5.74 \times 10^8$
540.05	39,600	3.45	$5.39 \times 10^8$	$18.60 \times 10^8$	$53.4 \times 10^8$
540.06	52,800	0.765	$7.80 \times 10^8$	$5.97 \times 10^8$	$17.1 \times 10^8$
540.07	71,280	0.515	$2.73 \times 10^8$	$1.41 \times 10^8$	$4.05 \times 10^8$
540.09	68,640	0.209	$5.77 \times 10^8$	$1.21 \times 10^8$	$3.47 \times 10^8$
540.11	52,800	1.268	$5.23 \times 10^8$	$6.63 \times 10^8$	$19.1 \times 10^8$
540.12	73,920	0.047	$6.76 \times 10^8$	$0.32 \times 10^8$	$0.91 \times 10^8$
540.13	27,050	1.440	$25.66 \times 10^8$	$36.95 \times 10^8$	$106.0 \times 10^8$
540.14	39,600	2.360	$5.25 \times 10^8$	$12.39 \times 10^8$	$35.6 \times 10^8$
540.15	72,000	0.228	$6.54 \times 10^8$	$1.49 \times 10^8$	$4.27 \times 10^8$
540.16	55,400	0.452	$12.10 \times 10^8$	$5.47 \times 10^8$	$15.7 \times 10^8$
540.17	~47,000	0.641	$6.67 \times 10^8$	$4.27 \times 10^8$	$12.25 \times 10^8$
540.18	44,880	1.533	$4.18 \times 10^8$	$6.41 \times 10^8$	$18.4 \times 10^8$
540.19	~33,000	3.105	$7.36 \times 10^8$	$22.85 \times 10^8$	$65.5 \times 10^8$
540.20	~26,000	1.125	$15.23 \times 10^8$	$17.13 \times 10^8$	$49.0 \times 10^8$
Jane†					
(damaged)	18,880	1.564	$7.75 \times 10^8$	$12.12 \times 10^8$	$34.7 \times 10^8$
Nancy	33,800	5.256	$6.13 \times 10^8$	$32.22 \times 10^8$	$92.5 \times 10^8$
Wilma	57,180	0.202	$5.51 \times 10^8$	$1.11 \times 10^8$	$3.18 \times 10^8$
Yvonne	75,520	0.026	$6.01 \times 10^8$	$0.156 \times 10^8$	$0.45 \times 10^8$
Elmer	115,060	0.0048	$0.23 \times 10^8$	$11.04 \times 10^4$	$28.0 \times 10^4$
Fred	124,580	0.022	$0.02 \times 10^8$	$4.40 \times 10^4$	$12.6 \times 10^4$

60  
**UNCLASSIFIED** - SECURITY INFORMATION

# UNCLASSIFIED

Table B.2 -- VOLUME AND ACTIVITY OF LIQUID FRACTION  
OF COLLECTED MATERIAL

Station	Distance from ground zero, ft	Volume residue, ml	Specific activity, c/m/ml	Total activity, c/m	Gross activity on unit area, c/m/sq ft
Total Collectors					
540.02	52,800	2645	$7.33 \times 10^3$	$2.29 \times 10^7$	$11.60 \times 10^7$
540.05	39,600	755	$25.36 \times 10^3$	$3.11 \times 10^7$	$15.9 \times 10^7$
540.06	52,800	375	$13.38 \times 10^3$	$1.14 \times 10^7$	$5.8 \times 10^7$
540.07	71,280	585	$3.45 \times 10^3$	$0.36 \times 10^7$	$1.83 \times 10^7$
540.09	68,640	645	$8.68 \times 10^3$	$0.97 \times 10^7$	$4.95 \times 10^7$
540.11	52,860	885	$29.20 \times 10^3$	$3.97 \times 10^7$	$20.2 \times 10^7$
540.12	73,920	555	$11.87 \times 10^3$	$1.22 \times 10^7$	$6.1 \times 10^7$
540.13	27,050	2755	$95.42 \times 10^3$	$30.82 \times 10^7$	$157.0 \times 10^7$
540.14	39,600	875	$51.78 \times 10^3$	$6.99 \times 10^7$	$35.7 \times 10^7$
540.15	72,000	1150	$13.26 \times 10^3$	$2.15 \times 10^7$	$10.9 \times 10^7$
540.16	55,400	975	$24.14 \times 10^3$	$3.50 \times 10^7$	$17.8 \times 10^7$
540.18	44,880	2905	$51.46 \times 10^3$	$17.39 \times 10^7$	$88.6 \times 10^7$
540.20	~26,400	1571	$2.58 \times 10^3$	$0.53 \times 10^7$	$2.7 \times 10^7$
Nancy	33,800	1620	$32.52 \times 10^3$	$5.27 \times 10^7$	$26.8 \times 10^7$
Wilma	57,180	1210	$54.32 \times 10^3$	$6.57 \times 10^7$	$33.4 \times 10^7$
Yvonne	75,520	1100	$1.54 \times 10^3$	$0.17 \times 10^7$	$0.87 \times 10^7$
Elmer	115,060	655	$0.48 \times 10^3$	$0.03 \times 10^7$	$0.16 \times 10^7$
Fred	124,580	480	$0.0 \times 10^3$	$0.00 \times 10^7$	$0.00 \times 10^7$
Bruce	102,670	405	$0.0 \times 10^3$	$0.00 \times 10^7$	$0.00 \times 10^7$
Rain-gage Buckets					
540.02	52,800	1610	$18.9 \times 10^3$	$3.04 \times 10^7$	$8.71 \times 10^7$
540.05	39,600	1100	$41.6 \times 10^3$	$4.62 \times 10^7$	$13.2 \times 10^7$
540.06	52,800	2000	$48.2 \times 10^3$	$9.64 \times 10^7$	$27.7 \times 10^7$
540.07	71,280	1462	$5.1 \times 10^3$	$0.75 \times 10^7$	$2.13 \times 10^7$
540.09	68,640	1000	$16.6 \times 10^3$	$1.66 \times 10^7$	$4.76 \times 10^7$
540.11	52,800	1140	$29.8 \times 10^3$	$3.40 \times 10^7$	$9.75 \times 10^7$
540.12	73,920	1820	$6.8 \times 10^3$	$1.24 \times 10^7$	$3.56 \times 10^7$
540.13	27,050	2830	$146.2 \times 10^3$	$41.37 \times 10^7$	$119.0 \times 10^7$
540.14	39,600	1380	$30.6 \times 10^3$	$4.22 \times 10^7$	$12.1 \times 10^7$
540.15	72,000	1100	$15.4 \times 10^3$	$1.69 \times 10^7$	$4.88 \times 10^7$
540.16	55,400	2470	$52.8 \times 10^3$	$13.04 \times 10^7$	$37.6 \times 10^7$
540.17	~47,000	2530	$61.6 \times 10^3$	$15.58 \times 10^7$	$44.8 \times 10^7$
540.18	44,880	2800	$64.4 \times 10^3$	$18.03 \times 10^7$	$51.7 \times 10^7$
540.19	~33,000	6575	$14.5 \times 10^3$	$9.53 \times 10^7$	$27.6 \times 10^7$
540.20	~26,000	3300	$341.0 \times 10^3$	$112.53 \times 10^7$	$322.0 \times 10^7$
Janet (damaged)	18,880	544	$183.89 \times 10^3$	$10.0 \times 10^7$	$28.7 \times 10^7$
Nancy	33,800	2650	$90.47 \times 10^3$	$23.97 \times 10^7$	$69.0 \times 10^7$
Wilma	57,180	1060	$17.00 \times 10^3$	$1.80 \times 10^7$	$5.17 \times 10^7$
Yvonne	75,520	670	$1.51 \times 10^3$	$0.10 \times 10^7$	$0.29 \times 10^7$
Elmer	115,060	760	$1.98 \times 10^3$	$0.15 \times 10^7$	$0.43 \times 10^7$
Fred	124,580	80	$0.98 \times 10^3$	$7.86 \times 10^4$	$22.4 \times 10^4$

UNCLASSIFIED

Table B.3--TOTAL ACTIVITY AND TOTAL MASS OF COLLECTED MATERIAL

Station	Total activity, c/m	Total activity on unit area, c/m/sq ft	Total mass on unit area, g/sq ft	Per cent of activity in solid
Total Collectors				
540.02	$0.34 \times 10^8$	$1.73 \times 10^8$	1.57	33.0
540.05	$0.97 \times 10^8$	$4.94 \times 10^8$	0.46	68.0
540.06	$0.14 \times 10^8$	$0.71 \times 10^8$	1.52	19.2
540.07	$0.06 \times 10^8$	$0.31 \times 10^8$	1.68	42.5
540.09	$0.49 \times 10^8$	$2.49 \times 10^8$	0.26	80.4
540.11	$0.41 \times 10^8$	$2.09 \times 10^8$	9.35	35.4
540.12	$0.22 \times 10^8$	$1.12 \times 10^8$	0.28	44.0
540.13	$12.26 \times 10^8$	$62.44 \times 10^8$	4.22	75.3
540.14	$1.72 \times 10^8$	$8.76 \times 10^8$	1.01	59.3
540.15	$0.32 \times 10^8$	$1.63 \times 10^8$	1.41	33.4
540.16	$0.87 \times 10^8$	$4.43 \times 10^8$	1.14	59.7
540.18	$13.15 \times 10^8$	$66.97 \times 10^8$	4.64	86.8
540.20	$0.06 \times 10^8$	$0.31 \times 10^8$	23.6	14.5
Nancy	$3.18 \times 10^8$	$16.20 \times 10^8$	1.66	83.3
Wilma	$1.54 \times 10^8$	$7.84 \times 10^8$	0.40	57.3
Yvonne	$1.51 \times 10^8$	$7.69 \times 10^8$	1.14	98.6
Elmer	$3.36 \times 10^5$	$17.11 \times 10^5$	0.09	5.9
Fred	$2.00 \times 10^4$	$10.19 \times 10^4$	0.005	100.0
Bruce	$8.00 \times 10^3$	$40.74 \times 10^3$	0.005	100.0
Rain-gage Buckets				
540.02	$2.30 \times 10^8$	$6.59 \times 10^8$	1.68	86.6
540.05	$19.06 \times 10^8$	$54.60 \times 10^8$	10.2	97.5
540.06	$6.93 \times 10^8$	$19.85 \times 10^8$	2.54	86.1
540.07	$1.48 \times 10^8$	$4.24 \times 10^8$	1.56	95.0
540.09	$1.37 \times 10^8$	$3.92 \times 10^8$	0.68	88.0
540.11	$6.97 \times 10^8$	$19.97 \times 10^8$	3.82	95.1
540.12	$0.44 \times 10^8$	$1.26 \times 10^8$	1.88	72.2
540.13	$41.09 \times 10^8$	$117.72 \times 10^8$	4.60	90.1
540.14	$12.81 \times 10^8$	$36.70 \times 10^8$	7.0	96.7
540.15	$1.66 \times 10^8$	$4.76 \times 10^8$	0.73	89.8
540.16	$6.77 \times 10^8$	$19.40 \times 10^8$	1.95	80.8
540.17	$5.83 \times 10^8$	$16.70 \times 10^8$	2.52	73.3
540.18	$8.21 \times 10^8$	$23.52 \times 10^8$	5.63	78.0
540.19	$23.81 \times 10^8$	$68.21 \times 10^8$	9.6	96.0
540.20	$28.39 \times 10^8$	$81.33 \times 10^8$	5.35	60.5
Janet	$13.12 \times 10^8$	$37.59 \times 10^8$	4.85	92.4
Nancy	$34.62 \times 10^8$	$99.18 \times 10^8$	16.2	93.1
Wilma	$1.29 \times 10^8$	$3.70 \times 10^8$	0.67	86.0
Yvonne	$0.17 \times 10^8$	$0.49 \times 10^8$	0.79	94.0
Elmer	$16.12 \times 10^5$	$46.18 \times 10^5$	0.20	6.8
Fred	$12.26 \times 10^4$	$35.12 \times 10^4$	1.7	35.9

UNCLASSIFIED — SECRET — SECURITY INFORMATION

# UNCLASSIFIED

Table B 4 — SECONDARY FALL-OUT DATA, GUMMED-PAPER COLLECTORS

Station	Sample	Corrected count, c/m	Date and time exposed (LST)	Date and time recovered (LST)	Approximate position		Remarks
					Lat. N	Long. E	
Kwajalein	1	790	301030	310830			
	2	0	310830	011400			
	3	0	011400	021230			
	4	63,060	021230	031000			
	5	210,590	031000	040930			
	6	19,650	040930	060800			
	7	3,560	060800	070800			
	8						Not exposed
	9						Not exposed
	10						Not exposed
	11						Not exposed
	12						Not exposed
Ponape	1	0	301300	311300			
	2	0	311300	011300			
	3	0	011300	021300			
	4	608	021300	031300			
	5	324	031300	041300			
	6	734	041300	051300			
	7	14,770	051300	061300			
	8	14,030	061300	071300			
	9	4,140	071300	091300			
	10	1,935	081300	091300			
	11	205	091300	101300			
	12						Not exposed
Johnston Island	1	0	300730	310730			
	2	0	310730	010730			
	3	0	010730	020730			
	4	0	020730	030730			
	5	0	030730	040730			
	6	0	040730	050730			
	7	1,450	050730	060730			
	8	0	060730	070730			
	9	0	070730	080730			
	10						Not exposed
	11						Not exposed
	12						Not exposed
Majuro	1	182	050300	060500			
	2	0	081500	091600			
	3	0	091600	111330			
	4						Not exposed
	5						Not exposed
	6						Not exposed
	7						Not exposed
	8						Not exposed
	9						Not exposed
	10	2,270	060500	081500			
	11	92,060	010300	051100			
	12	0	310300	010300			
Bikini	1	0	310800	312000			
	2	0	312000	010800			
	3	0	010800	011900			
	4	0	011900	020800			
	5	0	020800	021900			
	6	0	021900	030800			
	7	23,160	030800	032000			
	8	26,500	032000	030800			
	9	8,360	040800	042000			
	10						Not exposed
	11						Not exposed
	12						Not exposed
Kusare	1	0	010800	020400			
	2	0	020800	030300			
	3	0	030800	040800			
	4	3,200	040800	050800			
	5	11,000	050800	060800			
	6	250	050800	070400			

UNCLASSIFIED — RESTRICTED DATA — SECRET — SECURITY INFORMATION — UNCLASSIFIED

**UNCLASSIFIED**  
**SECRET**

Table B.4—(Continued)

Station	Sample	Corrected count, c/m	Date and time exposed (LST)	Date and time recovered (LST)	Approximate position		Remarks
					Lat. N	Long. E	
Ship off Ujelang	1	0	310700	311900	09° 30'	161° 20'	
	2	0	311900	010700	08° 33'	161° 02'	
	3	0	010700	011900	08° 10'	161° 15'	
	4	0	011900	020700	08° 45'	161° 15'	
	5	0	020700	021900	09° 37'	161° 15'	
	6	0	021900	030700	09° 17'	162° 15'	
	7	450	030700	031900	08° 50'	164° 22'	
	8						Not exposed
	8						Not exposed
	10						Not exposed
USS Rendova	1	0	010700	012100	None given		
	2	0	012100	020800			
	3	0	020900	021830			
	4	0	021830	030830			
	5	80,580	030830	031830			
	6	847,830	031830	051045			
	7	23,440	051040	051835			
	8	10,650	051830	060830			
	9	2,540	060830	081835			1 sq ft
	10	8,340	081830	070815			
USS Radford	1	371	310700	311900	11° 43'	162° 15'	
	2	0	311800	010635	11° 37'	162° 32'	
	3	0	010835	011900	11° 23'	162° 33'	
	4	0	011800	020700	11° 10'	162° 25'	
	5	2,720	020700	021900	11° 21'	162° 23'	
	6	9,880	021800	030700	11° 28'	162° 31'	
	7	114,000	030700	031800	11° 26'	162° 25'	
	8	992,800	031800	040700	11° 27'	162° 33'	
	9	45,380	040700	041800	11° 26'	162° 26'	
	10	58,570	041800	050700	11° 22'	162° 31'	
USS Carpenter	1	2,090	310700	010700	11° 37'	162° 08'	
	2	0	010700	011800	11° 14'	162° 48'	
	3	0	011800	020700	10° 53'	162° 43'	
	4	331	020700	021800	11° 15'	162° 48'	
	5	892	021900	030700	11° 09'	162° 48'	
	6	33,510	030700	031900	11° 01'	162° 56'	
	7	209,000	031900	040700	11° 04'	162° 15'	
	8	70,340	040700	041800	11° 04'	162° 58'	
	9	25,840	041800	050700	11° 04'	162° 20'	
	10	31,200	050700	060700	11° 13'	162° 30'	
USS Fletcher	1	0	310700	311800	11° 45'	162° 12'	
	2	0	311800	010700	11° 40'	162° 24'	
	3	0	010700	011900	11° 20'	162° 30'	
	4	0	011800	020700	11° 04'	162° 43'	
	5	0	020700	021800	11° 00'	162° 47'	
	6	410	021900	030700	10° 18'	164° 36'	
	7	133,680	030700	031800	08° 50'	167° 31'	
	8		031800	040700			Lost
	9	57,310	040700	041800	10° 10'	164° 53'	
	10	144,700	041800	050700	11° 22'	162° 20'	
USS Curtiss	1	0	310700	311900	316°	30 miles	Bearings and distance from Flora (true north)
	2	0	311900	010700	292.3	35 miles	
	3	285	010700	011900	282	35 miles	
	4	0	011900	020700	265	35 miles	
	5	0	020700	021800	338	22 miles	1 sq ft
	6		021900	030700	338	22 miles	Missing
	7	76,130	030700	031900	338	22 miles	
	8						Not exposed
	9						Not exposed
	10	72,180	031900	041540			

**RESTRICTED DATA - SECRET - SECURITY INFORMATION**  
**UNCLASSIFIED**

**UNCLASSIFIED**

Table B.4 - (Continued)

Station	Sample	Corrected count, c/m	Date and time exposed (LST)	Date and time recovered (LST)	Approximate position		Remarks
					Lat N	Long E	
USS Oa. Hill	1	0	310700	311900	11 20'	162 20'	
	2	0	311900	010945	11 20'	162 20'	
	3	0	010945	011900	11 20'	162 20'	
	4	0	011900	020700	11 20'	162 20'	
	5	0	020700	021900	11 20'	162 20'	
	6	941	021900	030700	11 20'	162 20'	
	7	80,970	030700	031900	11 20'	162 20'	
	8	1,177,560	031900	040700	11 20'	162 20'	
	9	182,600	040700	041900	11 20'	162 20'	
	10	138,800	041900	050700	11 20'	162 20'	
USS Agawam	1	0	310700	311900			1 sq ft
	2	0	311900	010700			
	3	0	010700	011900			
	4	0	011900	020700			
	5		020700	021900			Missing
	6	0	021900	030700			1 sq ft
	7	44,600	030700	031900			1 sq ft
	8	770,900	031900	040700			
	9	24,780	040700	041900			1 sq ft
	10	21,600	041900	050700			
USS Estes	1	0	310700	311900	11 24'	162 22'	
	2	0	311900	010615	11 15'	162 24'	
	3	0	010615	011900	11 17'	162 24'	
	4	0	011900	020700	11 10'	162 24'	
	5	821	020700	021900	11 24'	162 22'	1 sq ft
	6	2,770	021900	030700	11 24'	162 22'	Report 5 mr/hr fall-out
	7	9,270	030700	031900	11 24'	162 22'	
	8	925,060	031900	040700	11 24'	162 22'	Report 8 mr/hr fall-out
	9	74,760	040700	041900	11 24'	162 22'	
	10	21,390	041900	050700	11 24'	162 22'	
USS Leo	1	0	010700	011900			
	2	0	011900	020700			
	6	0	030900	040700			
	7	0	040700	041900			
	8	0	041900	050700			
	9	0	050700	051900			
USS O'Bannon	1	0	310700	311900	12 20'	164 35'	
	2	0	311900	010700	11 00'	165 05'	
	3	0	010700	011900	10 25'	165 05'	
	4	1,260	011900	020700	10 16'	164 31'	
	5	0	020700	021900	10 26'	164 30'	
	6	0	021900	030700	10 55'	164 20'	
	7	3,160	030700	031900	11 54'	164 37'	
	8	93,530	031900	040700	13 33'	164 48'	
	9	2,750	040700	041900	13 26'	163 50'	
	10	8,825	041900	050700	12 28'	162 24'	

**UNCLASSIFIED**      **SECRET**      **UNCLASSIFIED**

~~SECRET~~  
UNCLASSIFIED

Table B.5—FREE-FLOATING SEA STATIONS

Station	Volume, ml	Specific activity, c/m/ml	Total liquid activity, c/m	Solid, g	Specific activity, c/m/g	Total solid activity, c/m	Gross activity on unit area, c/m/sq ft
Total-collector Data							
1	405	$5.25 \times 10^3$	$2.13 \times 10^6$	0.0		$2.13 \times 10^6$	$1.08 \times 10^7$
2	540	$1.16 \times 10^3$	$0.63 \times 10^6$	0.0		$0.63 \times 10^6$	$3.21 \times 10^6$
5	800	$3.16 \times 10^3$	$2.53 \times 10^6$	0.0		$2.53 \times 10^6$	$1.29 \times 10^7$
10	610	$2.02 \times 10^3$	$1.23 \times 10^6$	0.0		$1.23 \times 10^6$	$6.26 \times 10^6$
11	690	$1.33 \times 10^3$	$0.92 \times 10^6$	0.0		$0.92 \times 10^6$	$4.69 \times 10^6$
12	660	$2.46 \times 10^3$	$1.62 \times 10^6$	0.0		$1.62 \times 10^6$	$8.25 \times 10^6$
13	460	$0.40 \times 10^3$	$0.18 \times 10^6$	0.28	$0.029 \times 10^8$	$0.99 \times 10^6$	$5.04 \times 10^6$
14	457	$10.00 \times 10^3$	$4.57 \times 10^6$	0.0		$4.57 \times 10^6$	$2.33 \times 10^7$
15	610	$0.40 \times 10^3$	$0.24 \times 10^6$	0.0		$0.24 \times 10^6$	$1.22 \times 10^6$
17	610	$0.04 \times 10^3$	$0.02 \times 10^6$	0.0		$0.02 \times 10^6$	$1.02 \times 10^5$
18	580	$0.11 \times 10^3$	$0.06 \times 10^6$	0.0		$0.06 \times 10^6$	$3.06 \times 10^5$
19	485	$11.69 \times 10^3$	$5.67 \times 10^6$	0.0		$5.67 \times 10^6$	$2.89 \times 10^7$
Gummed-paper Samples							
2						140,000	
5						320,000	
11						275	
12						2,940	
13						4,770	
14						17,250	
15						166,500	
17						41,500	
18						298,000	

~~SECRET~~  
UNCLASSIFIED — UNCLASSIFIED

~~SECRET~~  
**UNCLASSIFIED**

## APPENDIX C

### ELECTRONIC TRIGGER MECHANISM

#### C.1 PURPOSE

The electronic trigger mechanism (ETM) provides a means of initiating operation of the differential fall-out collector (DFOC) and other instruments from a light source intensity of 2 suns or more or a light-level differential of slightly more than 1 sun.

#### C.2 OPERATION

The ETM consists of two separate and distinct light-sensitive circuits, the phototube circuit (PT) and the photocell circuit (PC).

The PT circuit is the light-level-sensitive one. The light-sensitive element has three phototubes connected in parallel and so oriented that each receives light about a horizontal axis  $120^\circ$  from the other two. With the PT sensitivity potentiometer (Fig C.1) set for some predetermined light level, the circuit remains inactive until that light level is exceeded. When light strikes the phototubes, a current flows through the circuit containing the three 45-volt batteries, the phototubes, and the PT sensitivity potentiometer. This current causes a voltage drop across the PT sensitivity potentiometer. This voltage drop makes point 7 (the firing anode) on the tube (OA4) positive with respect to point 2 (cathode). As the light level increases, both the current and the voltage drop also increase. When the voltage drop reaches approximately 90 volts, OA4 will fire and operate the phototube relay (PTR). The circuit can be made to operate at a higher light level by decreasing the resistance of PT and at a lower light level by increasing it.

The PC circuit is a light-level-differential circuit and operates in almost complete darkness as long as the required differential intensity in light is available. The three photo-cells are connected in series along with the Sensitrol relay (SR) and a capacitor. The PC sensitivity potentiometer is shunted across the three cells.

If the intensity of light striking the cells is constant, then the current output of the cells is constant and all of it is shunted by PC and none flows through the SR coil and capacitor. However, if the intensity of light increases, current output from the photocells increases, the capacitor charge becomes less than the increased voltage drop across PC, and current flows from plus to minus through SR and the capacitor. Thus current flows through SR only when the light intensity is changing. The more rapid the change and the greater its magnitude, the larger will be the current through SR. When this current equals or exceeds a value of  $10 \mu\text{a}$  for approximately 0.5 sec, SR will operate and latch closed. The SR contacts in turn energize PTR, thereby achieving the same end function as the PT circuit.

Three sensitivity adjustments are available in the PC circuit. First, increasing the resistance of PC sensitivity potentiometer increases the sensitivity and conversely. Second, two

~~UNCLASSIFIED~~ ~~RESTRICTED DATA - SECRET~~ ~~SECURITY INFORMATION~~ ~~UNCLASSIFIED~~

RESTRICTED DATA - SECRET - SECURITY INFORMATION

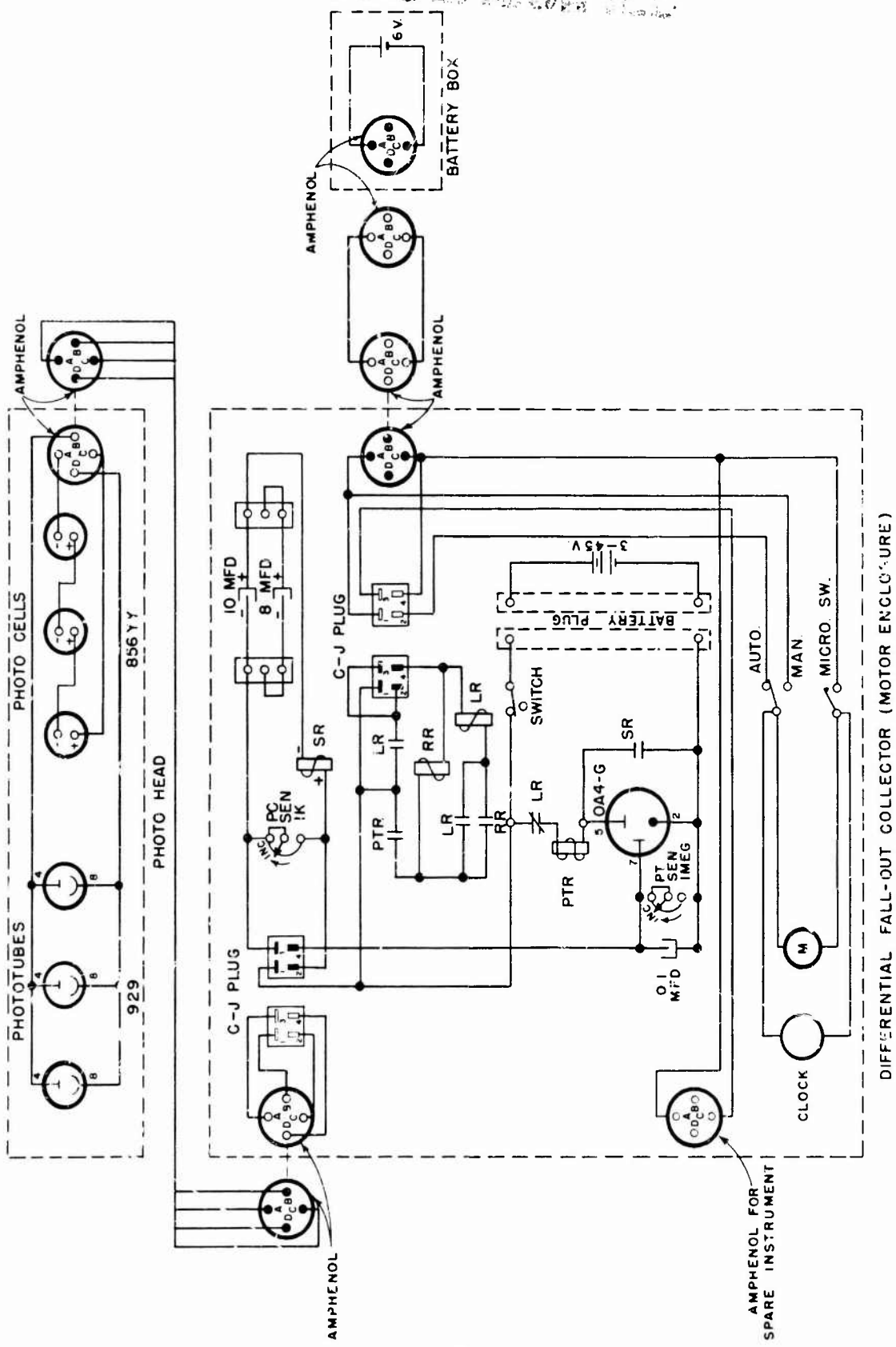

Fig. C.1 — Schematic diagram of the electronic trigger mechanism.

RESTRICTED DATA - SECRET - SECURITY INFORMATION

**UNCLASSIFIED**

capacitors are supplied, an 8 mfd and a 10 mfd. When the instrument is shipped, the 10-mfd capacitor is connected in the circuit in anticipation that this value of capacitance will place PC within range. If PC is not within range, it can be brought in range by changing values of capacitance. Increasing the capacitance will increase the sensitivity and conversely. Several values of capacitance can be obtained by using the capacitors singly or together: used singly, 10 mfd and 8 mfd are available; series connection of the capacitors yields 4.4 mfd, and parallel connection yields 18 mfd. Third, the sensitivity may also be adjusted by changing the zero setting of the Sensitrol relay. This method should be used only as a last resort.

As previously stated, both the PT and PC circuits energize PTR. The sequence of operation from that point follows: PTR picks up and energizes RR. RR picks up and energizes LR, which in turn (1) deenergizes PTR, (2) starts the electric motor, (3) starts the electric clock, and (4) energizes a solenoid to operate other instruments that may be used. PTR then drops out and deenergizes RR and LR.

The ETM may be removed from the DFOC by unplugging the two leads and removing four screws from the backplate. When this is done, the unit may be operated by throwing the "Auto-Man" switch on the motor mount assembly to the "Man" position.

### C.3 GENERAL COMMENTS

The ease or difficulty of sensitivity settings depends to a large extent upon the expected increase in light intensity above the ambient intensity at the particular position or position. If the expected increase is very large, then the sensitivity of both circuits can be set low, eliminating possible premature triggering by shadows or reflections. However, if the anticipated increase in intensity is to be only slightly above the ambient intensity, the settings become critical.

If the operation is to occur at dawn or dusk or any time other than a period of maximum ambient light intensity (i.e., high noon), the PC circuit sensitivity can be set quite low and still be triggered by a faint flash of light. If the flash of light occurs at any time other than a period of maximum ambient light intensity, then the actual light-level differential will be greater. The lower the ambient intensity, the greater the differential becomes and the less sensitive the PC circuit needs to be. Thus the PC circuit could be set up to operate on a light-intensity change of less than 1 sun and yet would not be operated by the noonday sun.

The foregoing is not true of the PT circuit. It must be desensitized to a point where the brightest anticipated sun will not operate it. Thus it appears that the PT circuit can be utilized best at positions relatively close to the source; the PC circuit can, under the conditions outlined above, be effectively utilized at much greater distances.

**RESTRICTED DATA - SECRET - SECURITY INFORMATION**  
**UNCLASSIFIED** **UNCLASSIFIED**

UNCLASSIFIED  
UNRESTRICTED DATA - SECRET - SECURITY INFORMATION

APPENDIX D

OPERATIONAL ORDERS AND PERSONNEL LOGISTICS

A project of this type requires very extensive planning, a high degree of coordination between widely separated component efforts, and the cooperation of many individuals. The extent of the effort expended in the conduct of this project is indicated in this appendix.

D.1 OPERATION ORDER

The following order to Task Group 132.3 delineates their participation in this project:

Joint Task Force 132  
Task Group 132.3  
Eniwetok Atoll, M. I.  
28 October 1952:1800M

Operation Order  
ComTaskGroup 132.3 No. 2-52

APPENDIX I TO ANNEX V—PROJECT 5.4a TASK GROUP 132.1

A. Launching and Recovery of Dan Buoys

Supporting Task Units:

- |                 |              |
|-----------------|--------------|
| (a) TU 132.33.3 | USS O'Bannon |
| (b) TU 132.32.4 | USS Yuma     |
| (c) TU 132.32.6 | USS Arikara  |
| (d) TU 132.3.0  | USS Rendova  |
| (e) TU 132.3.1  | Patron Two   |

1. General

Shot Participation: Mike  
Sponsor: Department of Defense  
Conducting Agency: NRDL  
Project Officer: LCDR Heldt, BuShips (Code 348)

Description: (a) This portion of Project 5.4a is concerned with measuring fall-out from the atomic cloud up to distances of approximately 150 miles from ground zero. Collection of fall-out is to be made in containers attached to free-floating Dan buoys which will be distributed in a pattern over the area where it is calculated the fall-out is likely to occur. Each Dan buoy weighs about 57 lb and consists of a balsa float, an 11-ft flagstaff on which is mounted a radar reflector, type MX-138A, and an identifying alphabet signal flag. (Flag on buoy No. 1 will be Able, No. 2 Baker, etc.) The collector and funnel will be clamped to the flagstaff.

UNCLASSIFIED  
UNRESTRICTED DATA - SECRET - SECURITY INFORMATION

**UNCLASSIFIED**  
**SECRET**

Gummed-paper surfaces will also be attached to the staff for the purpose of catching any particulate fall-out which may occur. A sea anchor will be used on each buoy to retard the drift due to wind.

(b) Dan buoys will be launched at the stations shown on the overlay for HO Chart 5413 (Tab A to this appendix, limited distribution) in accordance with the schedules shown in Tab B to this appendix.

2. Support Category

a. USS O'Bannon

(1) On a "primary mission" basis from 2100M on M-2 to 0130M on M-day.

b. USS Yuma

(1) On a "primary mission" basis from about 0630M on M-3 to 0910M on M-2.

(2) On a "primary mission" basis from 0700M M+1 until M+7.

c. USS Arikara

(1) If directed, to assist in recovery of Dan buoys by Commander, Task Group 132.3 (CTG 132.3), then on a "primary mission" basis after returning YC barges to Eniwetok Lagoon on Mike recovery (MR) day until not later than M+7 day.

d. USS Rendova

(1) On a "not to interfere with primary mission" basis.

e. Patron Two

(1) On a "primary mission" basis from M+1 until M+7.

3. Assignment of Tasks

a. Commanding Officer, USS O'Bannon, will

(1) Establish liaison with project officer and make arrangements for loading Dan buoys and auxiliary equipment and for embarking two project personnel who will assist in launching Dan buoys.

(2) Launch Dan buoys in accordance with plan from 2100M on M-2 until 0130M on M-day while en route to H-hour station.

(3) Assist in recovery of Dan buoys if so directed by CTG 132.3 after Mike shot. Recovery operations will not extend beyond M+7 day.

b. Commanding Officer, USS Yuma, will

(1) Establish liaison with project officer and make arrangements for loading Dan buoys and auxiliary equipment and for embarking two project personnel who will assist in launching and recovering Dan buoys and in preparing samples for shipment.

(2) Launch Dan buoys in accordance with plan from 0630 on M-3 until about 0910 on M-2.

(3) When released by CTG 132.3 after H-hour, proceed to best estimated position off northern end of Dan buoy line on 100-mile radius to arrive by 0700M M+1 day and commence recovery operations. After one sweep of 100-mile arc, search out and recover buoys on 150-mile arc.

c. Commanding Officer, USS Arikara, will

(1) Establish liaison with project officer and make arrangements for recovering Dan buoys after Mike shot and embark two project personnel for this purpose prior to Mike evacuation from Eniwetok Lagoon.

(2) If directed by CTG 132.3, after returning two of three or more barges to buoys in Eniwetok Lagoon on MR day, assist in recovery of Dan buoys from MR day until directed to cease by CTG 132.3, no later than M+7 day.

d. Commanding Officer, USS Rendova, will

(1) Plot locations of Dan buoys daily, using reports from patrol units and estimated drift of buoys.

(2) Inform CTG 132.3 daily of actual or best estimated positions of Dan buoys.

(3) Coordinate Dan buoy recovery operations between surface units and Patron Two aircraft.

e. Commanding Officer, Patron Two, will

**UNCLASSIFIED**

**SECRET**

**UNCLASSIFIED**  
**SECURITY INFORMATION**

**UNCLASSIFIED**  
**UNSECRET**

- (1) Provide one aircraft for outer line and one for inner line Dan buoy recovery to
  - (a) Report all buoy contacts to Rendova.
  - (b) Precede surface units on M+1 day into buoy areas to develop preliminary plot.
  - (c) Stand by to assist surface units in locating buoys.

4. The actual method of recovery will be at the discretion of the commanding officer concerned. In recovery of the buoy it is important that it be brought aboard essentially in a vertical position so that any liquid which has been collected in the polyethylene bottle will not be spilled. Care should also be taken to prevent extraneous material from coming in contact with the gummed-paper surfaces. Once the buoy is aboard, representatives from Project 5.4a will monitor the buoy and remove the samples.

5. All task element commanders and task unit commanders operating individually will report all contacts positively identified as Dan buoys to CTG 132.3, giving letter designation of signal flag on mast to Dan buoy (if it is visible), time of contact, and position. Prior to H-hour, patrolling units will report all contacts made on scheduled patrols but will not deviate from scheduled patrols to investigate, search out, and positively identify contacts in vicinity of planned buoy positions which appear to be Dan buoys. After M-day all patrolling units will identify possible Dan buoy contacts and report positive contacts to CTG 132.3, giving letter designation of signal flag on mast of Dan buoy (if it is visible), time of contact, and position. These position reports will be used to coordinate the direction and movement of recovery vessels.

6. Return buoys recovered to project officer on Elmer.

7. a. Commanding officers of launching and recovery vessels will report to CTG 132.3 at 6-hr intervals, using AFSAL 5104 to give

- (1) The letter designation, time, and position of launching of Dan buoys.
- (2) The letter designation, time, and position for Dan buoys when recovered.

b. Channel assigned: 552 kc CW and 2150 kc (voice).

c. Voice calls:

O'Bannon	Hickup Three
Yuma	Envious Four
Arikara	Envious Three
Rendova	Excellent Zero
P2V Aircraft	(NR) Cape Cod

d. Terminate recovery operations when directed.

8. Collection of Fall-out by Ships

a. Supporting Task Units:

- |                |               |
|----------------|---------------|
| 1. TU 132.30.0 | USS Curtiss   |
| 2. TU 132.31.0 | USS Estes     |
| 3. TU 132.31.4 | USS Leo       |
| 4. TU 132.31.0 | USS Oak Hill  |
| 5. TU 132.32.2 | USS Agawam    |
| 6. TU 132.33.0 | USS Carpenter |
| 7. TU 132.33.1 | USS Fletcher  |
| 8. TU 132.33.2 | USS Radford   |
| 9. TU 132.33.3 | USS O'Bannon  |
| 10. TU 132.3.0 | USS Rendova   |

b. Description: This portion of Project 5.4a is concerned with the installation of sticky-surface 1-ft-square plates aboard the ships listed above. The plates have been delivered by LCDR Heidt. They are to be installed and changed by ships' forces. Detailed instructions for installation and changing are secured to the lid of the box containing the sample plates. Plates will be returned to the project officer.

c. Support Category: Install and change plates in accordance with instructions received from Project 5.4a on a "not to interfere with primary mission" basis.

**UNCLASSIFIED**      **UNSECRET**      **UNCLASSIFIED**  
**UNCLASSIFIED**      **UNCLASSIFIED**

~~SECRET~~  
**UNCLASSIFIED**

C. W. Wilkins  
Rear Admiral  
Commander, Task Group 132.3

Tab A — Overlay for EO Chart 5413 (limited distribution)  
Tab B — Schedule for launching Dan buoys

AUTHENTICATED:  
(signed)  
A. C. Dragge, LCDR  
Flag Secretary

Joint Task Force 132  
Task Group 132.3  
Eniwetok Atoll, M. I.  
28 October 1952:1800M

Operation Order  
ComTaskGroup 132.3 No. 2-52

TAB A (REVISED) TO APPENDIX I TO ANNEX V

Overlay for chart HO5413  
HOLDERS OF ORIGINAL OVERLAY DELETE STATIONS 20-31

C. W. Wilkins  
Rear Admiral  
Commander, Task Group 132.3

DISTRIBUTION (Limited):

USS Radford (DDE-446)	(1)
USS O'Bannon (DDE-450)	(1)
USS Carpenter (DDE-825)	(1)
USS Fletcher (DDE-445)	(1)
USS Yuma (ATF-94)	(1)
USS Arikara (ATF-98)	(1)
USS Estes (AGC-12)	(1)
USS Curtiss (AV-4)	(1)
USS Rendova (CVE)	(1)
CO, Patrol Squadron Two	(1)
CTG 132.3	(1)
ComCortDesDiv 11	(1)
USS Lipan (ATF-85)	(1)

AUTHENTICATED:  
(signed)  
A. C. Dragge, LCDR  
Flag Secretary

Joint Task Force 132  
Task Group 132.3  
Eniwetok Atoll, M. I.  
21 October 1952:1200M

Operation Order  
ComTaskGroup 132.3 No. 2-52

73  
~~SECRET~~  
**UNCLASSIFIED** **UNCLASSIFIED**

~~UNCLASSIFIED~~  
~~SECRET~~

TAB B TO APPENDIX I TO ANNEX V

Schedule for Launching Dan Buoys

Ship: USS Yuma (ATF-94)  
Assumptions: 12-knot speed and buoy drift of 18 miles each 24 hr  
Schedule: USS Yuma depart Kwajalein in time to arrive at Station 8 by 0630M on M-3 day  
Distances: Kwajalein to Station 8 176 miles  
Station 8 to Station 7 26  
Station 7 to Station 6 26  
Station 6 to Station 5 25  
Station 5 to Station 4 25  
Station 4 to Station 3 28  
Station 3 to Station 2 25  
Station 2 to Station 1 27  
Station 1 to Deep Entrance 143  
-176  
Miles steamed after 0630 M-3 day 325

At an average speed of 12 knots, the trip should be completed in about 27+ hr after reaching Station 1 or about 0910M on M-2 day.

Ship: USS O'Bannon (DDE-450)  
Assumptions: 12-knot average speed and buoy drift of 18 miles each 24 hr  
Schedule: USS O'Bannon depart Eniwetok about 1700M on M-2 day  
Distances: Deep Entrance to Station 19 120 miles  
Station 19 to Station 18 25  
Station 18 to Station 17 25  
Station 17 to Station 16 25  
Station 16 to Station 15 25  
Station 15 to Station 14 26  
Station 14 to Station 13 25  
Station 13 to Station 12 26  
Station 12 to Station 11 26  
Station 11 to Station 10 26  
Station 10 to Station 9 28  
Station 9 to M-day position 29  
Total miles steamed 407

At an average speed of 12 knots, the trip should be completed in about 34.2 hr after leaving deep entrance or about 0315M on M-day.

Ship: USS Radford (DDE-446)  
Assumptions: 15-knot average speed and buoy drift of 18 miles in 24 hr  
Schedule: USS Radford arrive at Station 31 by 0800M on M-1 day  
Distances: Station 31 to Station 30 11 miles  
Station 30 to Station 29 15  
Station 29 to Station 28 11  
Station 28 to Station 27 11  
Station 27 to Station 26 16  
Station 26 to Station 25 16  
Station 25 to Station 24 16  
Station 24 to Station 23 16  
Total miles steamed placing buoys 112

~~UNCLASSIFIED~~

~~UNCLASSIFIED~~  
~~SECRET - SECURITY INFORMATION~~

**UNCLASSIFIED**

At an average speed of 15 knots, the last buoy should be in position in about 7.5 hr or by about 1530M on M-1 day.

C. W. Wilkins  
Rear Admiral  
Commander, Task Group 132.3

AUTHENTICATED:  
(signed)  
A. C. Dragge, LCDR  
Flag Secretary

JOINT TASK FORCE 132  
TASK GROUP 132.3  
WASHINGTON 25, D. C.

FF3/132.3/31:dn  
A4-3  
Ser: 0665  
16 Dec 1952

SUBJECT: Laying and Recovering Dan Buoys for Project 5.4a: recommendations concerning  
TO: Commander  
Task Group 132.1  
P.O. Box 1663  
Los Alamos Scientific Laboratory  
Los Alamos, New Mexico

1. Enclosure one is forwarded herewith.
2. The statement, as written, contained in paragraph 2e, is not concurred in. Those factors which prompted the recommendations set forth in paragraphs 4a(1) and 4a(5) of the enclosure are to a great extent the factors that precluded detection of the Dan buoys by the P2V aircraft. If recommendations 4a(1), 4a(2), and 4a(5) are incorporated in any future Dan buoy projects, such buoys, if laid within a security area over which ASW searches by radar-equipped aircraft are being conducted, will present a serious security problem owing to the similarity in radar return to that of a submarine snorkle.
3. If the information to be obtained from Dan buoys laid for future tests is of sufficient importance to warrant the added costs involved, it is recommended that suitably coded radar beacons be provided in each buoy in lieu of radar reflectors.

C. W. Wilkins  
Rear Admiral, U. S. Navy  
Commander

1 encl  
USS O'Bannon conf ltr  
066 of 12 Nov 1952  
Copies furnished  
BuShips (Code 348) (w/encl)  
12100649

DDE450/CO-hlb  
A4-3  
SER: 066  
12 November 1952

75

**UNCLASSIFIED** ~~SECRET~~ ~~SECURITY INFORMATION~~

UNCLASSIFIED  
SECRET

From: Commanding Officer  
To: Commander, Task Group 132.3  
Subj: Operation Ivy: recommendation regarding future operation similar to  
Ref: (a) CTG 132.3 restr disp 971736Z of November 1952  
Encl: (1) Data regarding recovery of Dan buoys for Project 5.4a, Operation Ivy  
(2) Chart indicating relative position, set, and drift of Dan buoys recovered for Project 5.4a

1. Reference (a) requested recommendations for consideration in planning and executing future operations similar to Operation Ivy. The only comments the Commanding Officer has to offer are those included herein, all of which pertain to the problem of laying and recovering Dan buoys such as those used in connection with Project 5.4a of Operation Ivy.

2. Enumerated below are certain observations based on the experience of this ship in laying, searching for, and recovering Dan buoys during Operation Ivy. It is realized that this experience is limited and that many of the observations, if accurate in general, may have been known to the planners of the operation in advance. However, even though they may be general knowledge, they are furnished for possible assistance to future planners.

a. No difficulties should be experienced in the physical operations of rigging, launching, and recovery of Dan buoys from a ship in any sea state up to heavy seas if the ship has a deck with less than 10 ft freeboard and is slowed to 5 knots for launching and stopped for recovery.

b. Currents in the sea area east of Eniwetok vary considerably, both in set and drift, with regard to both space and time. Enclosures (1) and (2) illustrate this statement.

c. Maximum reliable detection ranges by this ship for buoys of the type used (fitted with type MX-138A radar reflector) were as follows in a state 3 sea:

(1) Radar (both SG and EPS)—5000 yd

(2) Visual (eight lookouts in daylight with binoculars scanning forward 180° sector)—500 yd. Detection is better from low positions in the ship.

d. Reliable detection range is sensitive to sea conditions (8000-yd radar range and 1000-yd visual range observed with sea state 1).

e. Search by P2V aircraft with AN/APS-20 radar is ineffective in state 3 sea (based on 14-hr continuous search over buoy line with no contacts).

f. Using radar search, location, and recovery of buoys during darkness is as expeditious as during daylight.

g. In an expanding search, missing a buoy close to its predicted position wastes as much time as having its position more uncertain than the maximum allowed for in the search plan.

3. Certain basic factors with regard to surface search should be taken into consideration in planning:

a. Under given circumstances of sea state, weather, and equipment, the time spent in a successful search for any buoy is a direct function of the uncertainty of positions of the buoy and an inverse function of the search rate (area searched per unit time).

b. The uncertainty of position is the product of the uncertainty in set and drift and the elapsed time since the buoy was laid.

c. The search rate is directly proportional to ship speed if an efficient search plan is used.

d. In picking up a series of buoys, the elapsed drifting time (and hence the uncertainty of position) of later buoys increases with the time required to locate earlier buoys. Thus higher speed, in addition to reducing the time required for recovery by increasing the search rate, has a cumulative effect when a series of buoys is to be recovered because it reduces drifting time of later buoys and therefore also reduces total miles steamed. Similarly, if a series of buoys must be laid by a time deadline, higher speed in laying reduces the drifting time of the earlier buoys and therefore also reduces total miles steamed.

4. As a result of the foregoing observations and factors, the following recommendations are submitted for consideration in future operations:

UNCLASSIFIED — SECRET — SECURITY INFORMATION

**UNCLASSIFIED**

a. Attempt to extend the detection range of the buoys to increase search rates. The following methods are suggested:

- (1) Increase the height of the antenna mast to raise the radar reflector and thereby increase radar detection range.
- (2) Utilize a reflector more responsive to the AN/APS-20 aircraft radar.
- (3) Utilize a blinking light on the buoy, set to turn on at commencement of search operations.
- (4) Utilize a radio or radar beacon, set to be activated at commencement of search operations, on the first buoy to be recovered.
- (5) Secure the sea anchor above the float rather than to the bail of the buoy to counteract the tilting moment exerted on the buoy by the wind and make the buoy drift with the antenna mast erect.

b. Utilize high-speed ships (15 to 20 knots) for both laying and recovery to minimize recovery time and increase certainty of recovery.

c. Utilize more than one ship for recovery, commencing searches at different parts of the buoy line.

d. Either station each recovery ship close enough to a buoy to observe it during its drifting time or have the ship drop and track a spare buoy if practicable during the waiting period prior to commencement of recovery operations.

5. Enclosure (2) shows the plot of buoys recovered, based on a constant set and drift for each buoy during its drifting time. It should be noted that certain buoy tracks appear to have "crossed" in the open sea. The fallacy ascribing constant set and drift to each buoy is thus highlighted. The red dashed lines on the chart show how the buoy drift could have been along stream lines in each case and still have produced a pattern of drifted buoys experienced.

6. Sufficient copies of this letter are being forwarded to provide copies to CTG 132.1 if desired. Members of the staff of that group have advised informally that any matter regarding technique of buoy laying and recovery will be of interest.

/s/ E. B. Jarman

From: Navigator  
To: Commanding Officer  
Via: Executive Officer  
Subj: Project 5.4a, Set and Drift of Buoys: observation of  
Encl: Plotting chart

1. The following observations have been made and are hereby submitted for future reference:

UNCLASSIFIED  
SECRET

Buoy	Launched		Recovered		Set	Drift, knot
	Time	Position	Time	Position		
Item	010045	10° 15' N, 164° 29.5' E				
Jig	312245	10° 37' N, 164° 45' E	021810	10° 43.5' N, 164° 13' E	281°T	0.70
King	312048	11° 01' N, 164° 54' E	030650	11° 23.5' N, 164° 25' E	307°T	0.60
Love	311858	11° 26' N, 165° 00' E	031410	11° 44' N, 164° 36.3' E	305°T	0.43
Mike	311652	11° 52.5' N, 164° 58.9' E	031930	12° 10.3' N, 164° 20' E	293°T	0.61
Nan	311451	12° 19.2' N, 164° 58.9' E	032200	12° 39.5' N, 164° 04' E	202°T	0.73
Oboe	311248	12° 42.0' N, 164° 50' E	040000	13° 06' N, 163° 58' E	295°T	0.70
Peter	311012	13° 05' N, 164° 37' E				
Queen	310800	13° 25' N, 164° 22' E	041355	13° 38.8' N, 163° 02.8' E	280°T	0.77
Roger	310557	13° 08' N, 164° 06' E	041740	13° 13.3' N, 162° 39' E	274°T	0.78
Sugar	310340	12° 50' N, 163° 49' E	042040	12° 46' N, 162° 10' E	268°T	0.85
Able	292030	12° 29' N, 164° 31' E	042150	12° 41' N, 162° 18.8' E	275°T	0.89
Baker	210330	12° 05' N, 164° 42' E	050520	12° 09' N, 162° 28' E	272°T	0.87
Charlie	291630	11° 40' N, 164° 45' E				
Dog	291430	11° 13' N, 164° 43' E				
Easy	291230	10° 50' N, 164° 33' E	060115	10° 45.5' N, 162° 23.0' E	267°T	0.69
Fox	291030	10° 30' N, 164° 33' E				
George	290830	10° 13' N, 164° 38' E				
How	280630	9° 55' N, 164° 57' E				

/s/ H. G. Kuntz, LT, USNR  
ENCLOSURE (2)

## D.2 PERSONNEL LOGISTICS

The following is a list of the NRDL and other personnel who were engaged in this project and the work for which they were primarily responsible.

### D.2.1 Design of Instruments and Equipment

F. A. Adams, LTJG  
D. N. Leonardos  
G. Lilk  
W. L. Snapp

### D.2.2 Laboratory Work on Samples

S. C. Foti	J. N. Pascual
A. E. Greendale	J. F. Pestaner
W. J. Heiman	J. T. Quan
M. Honma	E. W. Roberts
C. F. Miller	J. A. Seiler
M. J. Nuckolls	W. H. Shipman
J. D. O'Connor	W. Simon

RESTRICTED DATA - SECRET - SECURITY INFORMATION  
UNCLASSIFIED

UNCLASSIFIED  
SECRET

D.2.3 On-site Personnel

F. J. D'Amico	BM2	C. P. Jones	BM1
T. R. Broida		R. W. Myers	CD2
C. A. Graves	CD1	R. P. Nicolson	
T. A. Hamilton	BM1	W. L. Snapp	
A. J. Hodges, Jr.		L. T. Tice	BM2
R. C. Johnston	CD2		

D.2.4 Fall-out Stations on Land

The weather station personnel at the islands were responsible for the fall-out stations located on Ponape, Majuro, Johnston, and Kusaie.

D.2.5 Fall-out Stations on Ships

The crews of the ships were responsible for the fall-out stations located aboard the USS Rendova, USS Radford, USS Carpenter, USS Fletcher, USS Curtiss, USS Oak Hill, USS Agawam, USS Estes, USS Leo, USS O'Bannon, and the LST off Ujelang.

D.2.6 Free-floating Sea Stations

The crews of the USS O'Bannon and the USS Yuma assisted in the laying and recovery of the free-floating sea stations.

UNCLASSIFIED DATA - SECRET - SECURITY INFORMATION  
UNCLASSIFIED



Defense Special Weapons Agency  
6801 Telegraph Road  
Alexandria, Virginia 22310-3398

JUN 11 1997

OPSSI

MEMORANDUM FOR DISTRIBUTION

SUBJECT: Declassification Review of Operation IVY Test Reports

The following 31 (WT) reports concerning the atmospheric nuclear tests conducted during Operation IVY in 1952 have been declassified and cleared for open publication/public release:

WT-602 through WT-607, WT-609 thru WT-618, WT-627 thru WT-631, WT-633, WT-635, WT-636, WT-639, WT-641 thru WT-644, WT-646, and WT-649.

An additional 2 WTs from IVY have been re-issued with deletions. They are:

WT-608, WT-647.

These reissued documents are identified with an "Ex" after the WT number. They are unclassified and approved for open publication.

This memorandum supersedes the Defense Nuclear Agency, ISTS memorandum same subject dated August 17, 1995 and may be cited as the authority to declassify copies of any of the reports listed in the first paragraph above.

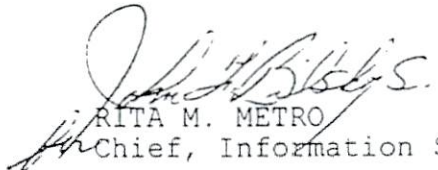
  
RITA M. METRO  
Chief, Information Security