

UNCLASSIFIED

AD NUMBER

AD474473

LIMITATION CHANGES

TO:

Approved for public release; distribution is unlimited.

FROM:

Distribution authorized to U.S. Gov't. agencies and their contractors; Specific Authority; DEC 1965. Other requests shall be referred to Arnold Engineering Development Center, Arnold AF Station, TN.

AUTHORITY

AEDC ltr, 16 Oct 1974

THIS PAGE IS UNCLASSIFIED

AEDC-TR-65-241

**ARCHIVE COPY
DO NOT LOAN**

eyl



**INVESTIGATION OF VARIOUS FULL-SCALE PARACHUTES
AT MACH NUMBER 3.0**

David E. A. Reichenau

ARO, Inc.

*This document is released
Per AF letter dtd
16 October 1974 signed
William O. Bell.*

December 1965

PROPERTY OF U. S. AIR FORCE
AEDC LIBRARY
AF-40(600)1200

**PROPULSION WIND TUNNEL FACILITY
ARNOLD ENGINEERING DEVELOPMENT CENTER
AIR FORCE SYSTEMS COMMAND
ARNOLD AIR FORCE STATION, TENNESSEE**

AEDC TECHNICAL LIBRARY



5 0720 00031 1797

NOTICES

When U. S. Government drawings specifications, or other data are used for any purpose other than a definitely related Government procurement operation, the Government thereby incurs no responsibility nor any obligation whatsoever, and the fact that the Government may have formulated, furnished, or in any way supplied the said drawings, specifications, or other data, is not to be regarded by implication or otherwise, or in any manner licensing the holder or any other person or corporation, or conveying any rights or permission to manufacture, use, or sell any patented invention that may in any way be related thereto.

Qualified users may obtain copies of this report from the Defense Documentation Center.

References to named commercial products in this report are not to be considered in any sense as an endorsement of the product by the United States Air Force or the Government.

Defense Documentation Center release to the Clearinghouse for Federal Scientific and Technical Information (CFSTI) and foreign announcement and distribution of this report are not authorized. The distribution of this report is limited because it contains technology identifiable with items excluded from export by the Department of State.

INVESTIGATION OF VARIOUS FULL-SCALE PARACHUTES
AT MACH NUMBER 3.0

David E. A. Reichenau
ARO, Inc.

This document has been approved for public release
its distribution is unlimited. *Per AF Letter 246
16 October, 1974 signed
William O. Cole*

FOREWORD

The work reported herein was done at the request of and for the Air Force Flight Dynamics Laboratory (AFFDL), Research and Technology Division (RTD), Air Force Systems Command (AFSC), under Program Element 62405364, Project 6065.

The results of the test were obtained by ARO, Inc. (a subsidiary of Sverdrup and Parcel, Inc.), contract operator of the Arnold Engineering Development Center (AEDC), AFSC, Arnold Air Force Station, Tennessee, under Contract AF40(600)-1200. The test was conducted from August 11 to 13 and on September 30, 1965 under ARO Project No. PS0609, and the manuscript was submitted for publication on October 26, 1965.

This technical report has been reviewed and is approved.

Francis M. Williams
Major, USAF
AF Representative, PWT
DCS/Test

Jean A. Jack
Colonel, USAF
DCS/Test

ABSTRACT

Several hyperflo and parasonic parachutes and one hemisflo parachute were tested in the 16-ft supersonic wind tunnel to obtain drag, inflation, and stability characteristics at a nominal Mach number of 3.0 and a nominal free-stream dynamic pressure of 120 psia. The effects of various types of roof mesh and material on the aerodynamic characteristics of the parachutes were obtained. These data show that the hyperflo parachutes had higher drag loads but less inflation and stability than the corresponding parasonic parachutes with the same combination of roof mesh and material. Differences in roof designs resulted in a drag variation of approximately 25 percent for both the hyperflo and parasonic series of 4-ft nominal diameter parachutes.

This document has been approved for public release
and its distribution is unlimited.

*Per AF Letter
dated 16 October 1974 signed
William O. Cole*

CONTENTS

	<u>Page</u>
ABSTRACT.	iii
NOMENCLATURE.	vi
I. INTRODUCTION	1
II. APPARATUS	
2.1 Test Facility.	1
2.2 Test Article	1
2.3 Instrumentation.	3
III. PROCEDURE.	3
IV. RESULTS AND DISCUSSION	
4.1 Deployment Loads	4
4.2 Steady-State Loads	4
4.3 Inflation and Stability Characteristics.	5
V. CONCLUDING REMARKS	6

ILLUSTRATIONS

Figure

1. Model Centerbody Dimensions	7
2. Location of Model in Test Section	8
3. Installation of Full-Scale Model Centerbody in Test Section.	9
4. Three-Quarter Rear View of Model Centerbody	10
5. Hyperflo Parachute Details, Configurations 1 through 5 and Configuration 15	11
6. Hyperflo Parachute.	12
7. Configuration 15, with Quarter-Inch Webbing Mesh Roof.	13
8. Parasonic Parachute Details, Configurations 6 through 10.	14
9. Parasonic Parachute Details, Configurations 11 and 12	15
10. Parasonic Parachute Details, Configuration 14	16

<u>Figure</u>	<u>Page</u>
11. Parasonic Parachute.	17
12. Hemisflo Parachute Details, Configuration 13	18
13. Hemisflo Parachute	19
14. Parachute Deployment Characteristics.	20

TABLES

I. Summary of Parachute Details.	29
II. Parachute Test Conditions and Results	30

NOMENCLATURE

A_e	Parachute exit area, sq ft
A_i	Parachute inlet area, sq ft
C_{D_o}	Parachute drag coefficient, $\frac{F_D}{q_\infty S_o}$
D_o	Parachute nominal diameter, ft
d	Model centerbody diameter, 1.47 ft
F_D	Parachute drag force, lb
M_∞	Free-stream Mach number
q_∞	Free-stream dynamic pressure, psfa
R_c	Parachute cap radius, ft
S_o	Parachute drag-producing surface, ft ²
X	Distance from aft end of centerbody to parachute inlet, ft

SECTION I INTRODUCTION

A test was conducted in the 16-ft supersonic tunnel (Propulsion Wind Tunnel, Supersonic (16S)) of the Propulsion Wind Tunnel Facility (PWT) to determine the steady-state drag, inflation, and stability characteristics of parachutes in supersonic flow. It was also desired to establish the influence of the various roof meshes on parachute stability. The parachutes investigated during this test were of the hyperflo, parasonic, and hemisflo configurations. All of the parachutes were tested at a nominal Mach number of 3.0 and a free-stream dynamic pressure of 120 psfa.

SECTION II APPARATUS

2.1 TEST FACILITY

Tunnel 16S is a closed-circuit, continuous flow wind tunnel currently capable of operating at Mach numbers from 1.65 to 3.20. The tunnel is capable of operating over a stagnation pressure range from 100 to 1600 psfa. The test section stagnation temperature can be controlled through the range from 100 to 650°F. The wind tunnel specific humidity is controlled by removing tunnel air and supplying makeup air from an atmospheric dryer. A more complete description of the facility and its operating characteristics is contained in the Test Facilities Handbook.¹

2.2 TEST ARTICLE

2.2.1 Model Centerbody and Deployment System

The parachutes tested during this investigation were deployed from a strut-mounted centerbody. Dimensions of the centerbody are presented in Fig. 1, and the location of the centerbody in the wind tunnel is shown in Fig. 2. The wind tunnel installation of the centerbody is shown in Fig. 3.

¹Test Facilities Handbook (5th Edition). "Propulsion Wind Tunnel Facility, Vol. 3." Arnold Engineering Development Center, July 1963.

The parachutes were packed in the aft end of the centerbody on a spring-loaded plate and were held against the plate by retaining straps. The retaining straps were released by a squib-fired release-pin mechanism. A three-quarter rear view of a parachute packed in the aft end of the centerbody is shown in Fig. 4. The parachute riser line was affixed to a load cell inside the centerbody by means of a swivel which was used to prevent twisting of the parachute suspension lines. A shear pin, designed to protect the load cell, was used to connect the parachute riser line to the swivel.

2.2.2 Parachutes

The parachutes tested were of three general types: hyperflo, parasonic, and hemisflo. Specific construction details and photographs of the parachutes are shown in Figs. 5 through 13.

The six hyperflo (truncated-cone shape) parachute configurations had a nominal diameter of 4 ft. Five of the hyperflo parachutes, Configurations 1 through 5 shown in Fig. 6, had differently constructed mesh roofs made of nylon or Perlon[®] thread. The porosity of each parachute, Configurations 1 through 5, was kept approximately the same by using porosity bands built into the roofs of the parachute canopies. Configuration 15, also shown in Fig. 6, had a mesh roof constructed of 1/4-in. -wide cotton webbing. The skirt, porosity band, suspension lines, and riser lines of the hyperflo parachutes were of nylon construction. The parachute porosity, as used in this report, is defined as the ratio of the open area in the drag-producing surface to the total area of the drag-producing surface.

The details of the parasonic parachutes, Configurations 6 through 12 and Configuration 14, are shown in Figs. 8, 9, and 10. The parasonic parachutes were constructed in the shape assumed by a hyperflo parachute when it is in a fully inflated condition. The 4-ft nominal diameter parasonic parachutes, Configurations 6 through 10, shown in Fig. 8, were constructed of identical roof mesh and nylon material as a corresponding hyperflo configuration (as shown in Table I). The porosity of each of these five configurations was kept essentially the same by varying the porosity band in the roof. The porosities of the parasonic parachutes were slightly lower than those of the corresponding hyperflo parachutes. Configurations 11 and 12 were identical parasonic parachutes with a nominal diameter of 5.5 ft. These two parasonic parachutes were of nylon construction. The specific construction details and a photograph are shown in Figs. 9 and 11, respectively. Configuration 14, shown in Fig. 10, was constructed of the identical cotton webbing and nylon material that was used for hyperflo Configuration 15.

Configuration 13, a hemisflo parachute, had a roof and skirt constructed of 0.75-in. -wide nylon ribbons and 14.5-in. -wide solid nylon mesh, respectively. The riser and suspension lines were also nylon. The hemisflo parachute had a nominal diameter of 6 ft and a porosity of 8 percent. Details of Configuration 13 are shown in Fig. 12; a photograph of this parachute is shown in Fig. 13.

2.3 INSTRUMENTATION

A 5000-lb-capacity, double-element load cell was used to measure the drag load of the parachutes. A direct-writing oscillograph was used to monitor the parachute drag load during testing. Four motion-picture cameras and two television cameras, installed in the test section walls, were used to document and monitor these tests.

SECTION III PROCEDURE

A parachute was packed into the aft end of the strut-mounted centerbody before initiation of the wind tunnel test operations. Once test conditions were established, the parachute was ejected from the centerbody into the airstream. Motion pictures and dynamic drag data were obtained during and after each deployment. Upon the completion of the parachute deployment sequence, a steady-state load drag was calculated by averaging the analog output signal from the strain-gage load cell over a 1-sec interval.

All of the parachute configurations were deployed at a nominal Mach number and free-stream dynamic pressure of 3.0 and 120 psfa, respectively. The centerbody was maintained at zero angle of attack and yaw for the entire test. A complete summary of test conditions is presented in Table II.

SECTION IV RESULTS AND DISCUSSION

Fifteen parachute deployments were made at a Mach number of 3.0 and a free-stream dynamic pressure of 120 psfa. Data were obtained at Mach number 3.0 for all of these parachutes except Configuration 3, which failed on deployment. Additional data were obtained at Mach numbers of 2.8 and 2.6 for Configuration 14. All other parachutes failed before a new

Mach number condition could be established. A complete summary of the test results is given in Table II.

4.1 DEPLOYMENT LOADS

Deployment of parachutes generally creates two forces known as the "snatch force" and the "opening shock force." For wind tunnel testing of parachutes, the snatch force is defined as that force imposed on the centerbody by the deceleration of the mass of the parachute from its velocity at line extension to zero velocity relative to the centerbody. The snatch force is followed closely by the opening shock force, which is defined as that force imposed on the centerbody by the sudden inflation of the parachute at full line extension.

For the fifteen parachute configurations investigated, the snatch and opening shock forces were found to vary considerably during each deployment, since they are a function of the parachute packing procedure. The deployment-time histories of each of the parachute configurations are shown in Fig. 14. As shown in Figs. 14b and d, Configurations 2 and 4 had extremely high snatch forces. Analysis of motion pictures of these two configurations shows that the parachutes separated from the deployment can before the parachute reached full line extension, thus superimposing the opening shock force on the snatch force. Several of the parachute configurations tested later were repacked and reinforced with "break thread" to prevent premature opening of the parachutes. The snatch and opening shock forces for all the parachutes varied between 250 and 1200 lb, and between 500 and 1800 lb, respectively.

4.2 STEADY-STATE LOADS

The drag coefficient for each of the parachute configurations is presented in Table II. The drag coefficients for the parachutes investigated ranged from 0.21 to 0.30.

The 4-ft hyperflo parachutes (Configurations 1 through 5 and 15) had a higher drag coefficient than the corresponding 4-ft parasonic parachute with identical roof mesh and material (Configurations 6 through 10 and 14). It is believed that the higher drag coefficients obtained with the hyperflo parachutes were a result of the particular parachute design rather than the small variations in porosity and inlet-to-exit area ratios between the corresponding hyperflo and parasonic parachute configurations. In general, a hyperflo parachute has a slightly larger inflated diameter than a parasonic parachute of the same nominal diameter. The drag coefficient was also affected by varying the mesh roof design in the 4-ft parachute configurations. Differences in the roof designs resulted in a drag coefficient

variation of approximately 25 percent for the hyperflo and parasonic series of 4-ft parachutes. Configurations 1 and 6 had the highest drag coefficients for the hyperflo and parasonic parachutes, respectively. The difference in the drag coefficients for the two identical 5.5-ft nominal diameter parasonic parachutes (Configurations 11 and 12) was caused by underinflation of Configuration 12, thus producing a smaller drag load. Configuration 13, a 6-ft nominal diameter hemisflo parachute, had the largest drag coefficient of the parachutes tested, a value of 0.304.

4.3 INFLATION AND STABILITY CHARACTERISTICS

Photographic coverage obtained by motion-picture cameras permitted the determination of the parachute inflation and stability characteristics. Analysis of the motion pictures indicated that the 4-ft parasonic parachute configurations exhibited full canopy inflation during each deployment. However, the hyperflo parachute configurations, with the exception of Configuration 1, exhibited less inflation stability than did the parasonic parachutes because of squidding and skirt flutter. Configurations 12 and 13, the 5.5-ft parasonic and 6-ft hemisflo parachutes, respectively, also exhibited full canopy inflation. For no apparent reason, Configuration 11, identical in construction to Configuration 12, exhibited underinflation.

The parachute stability characteristics as discussed in this report pertain to the motion of the canopy in a plane perpendicular to the centerline of the centerbody. The motion was defined in terms of maximum oscillation angle and oscillation frequency about the riser line to centerbody attachment point and was evaluated from motion pictures. A tabulation of the stability characteristics for the parachute configurations is presented in Table II. The oscillation angle of the 4-ft hyperflo parachutes varied between ± 6.5 and ± 13 deg, whereas the oscillation angle of the 4-ft parasonic parachutes varied between ± 3.5 and ± 12 deg. The oscillation frequency of the 4-ft hyperflo and parasonic parachutes varied between 4.0 and 4.5 cps and 2.0 and 4.0 cps, respectively. In each case, for a given parachute roof mesh and material, the parasonic parachute configuration had a lower oscillation angle and frequency than did the hyperflo parachute configuration. For Configuration 14, where data were obtained at Mach numbers of 3.0, 2.8, and 2.6, the oscillation angle and frequency decreased with decreasing Mach number.

SECTION V CONCLUDING REMARKS

Tests were conducted to investigate the drag, inflation, and stability characteristics of several parachutes with various roof mesh and material combinations in supersonic flow. The following observations are a result of these tests:

1. The hyperflo parachute configurations had a higher drag coefficient than the corresponding parasonic parachute configuration with identical roof mesh and material.
2. Differences in roof designs resulted in a drag coefficient variation of approximately 25 percent for both the hyperflo and parasonic series of 4-ft parachutes.
3. The inflation and stability characteristics of the parasonic parachute configuration were better than those of the corresponding hyperflo parachute configuration with identical roof mesh and material.

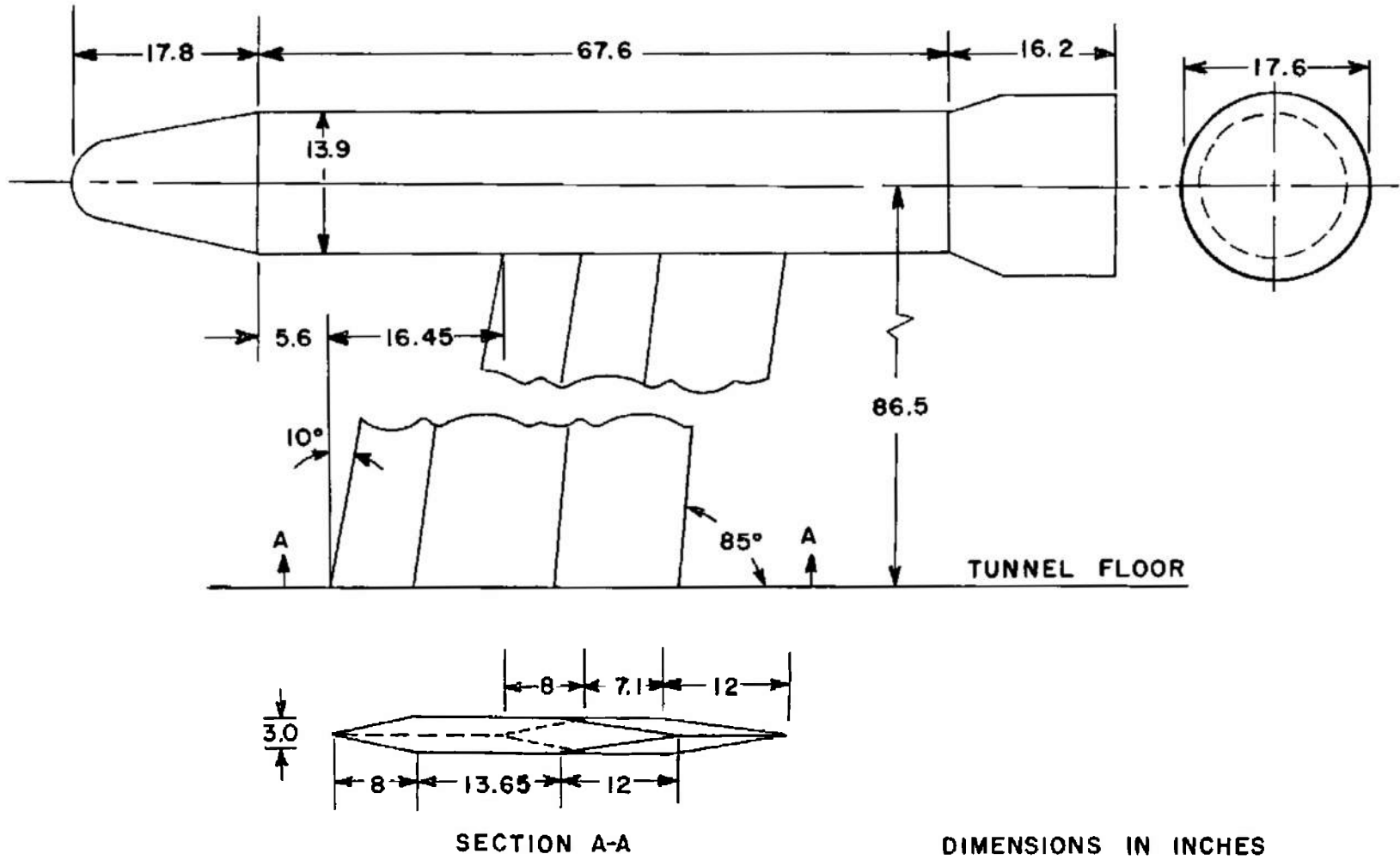

Fig. 1 Model Centerbody Dimensions

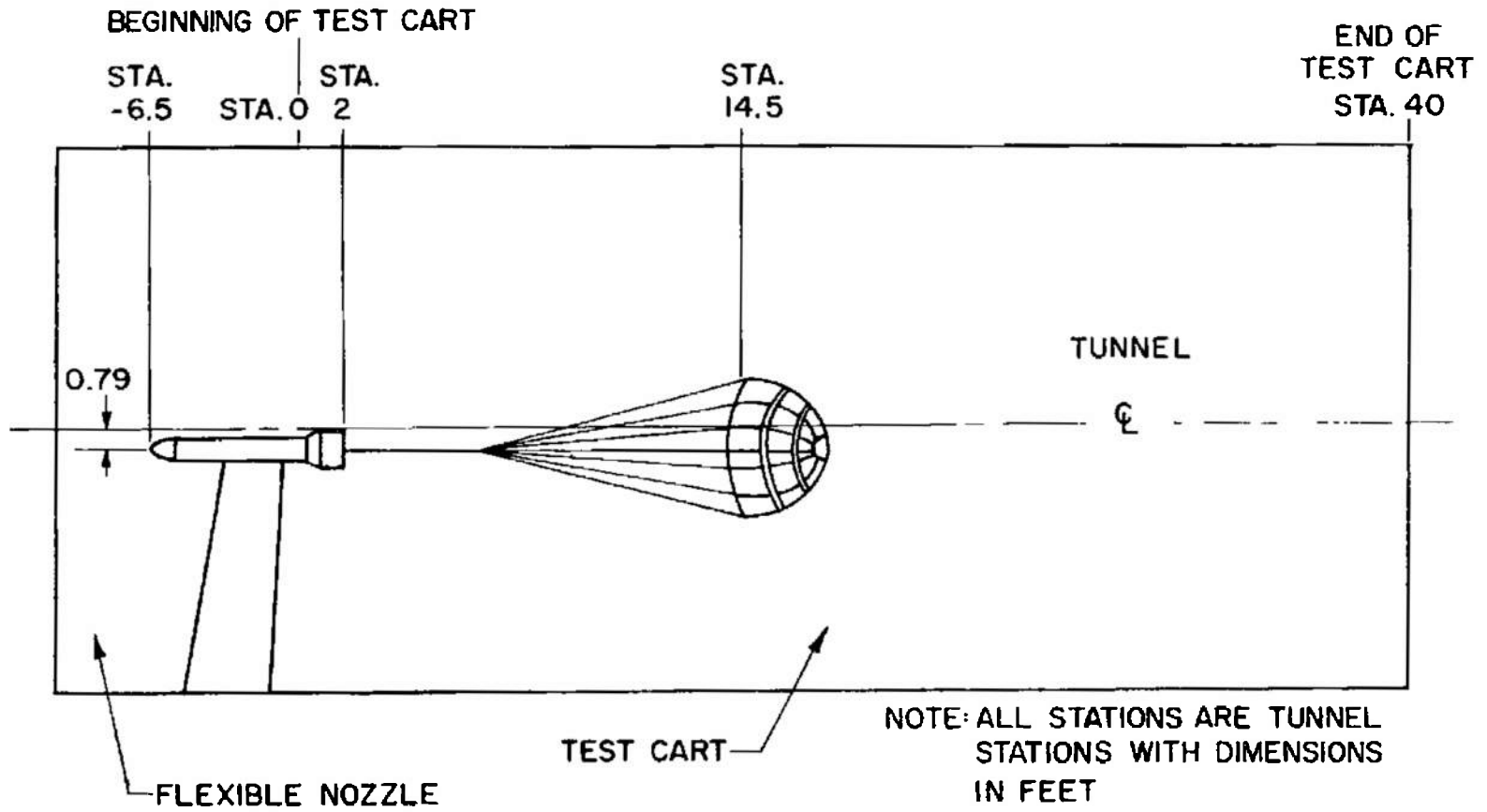

Fig. 2 Location of Model in Test Section

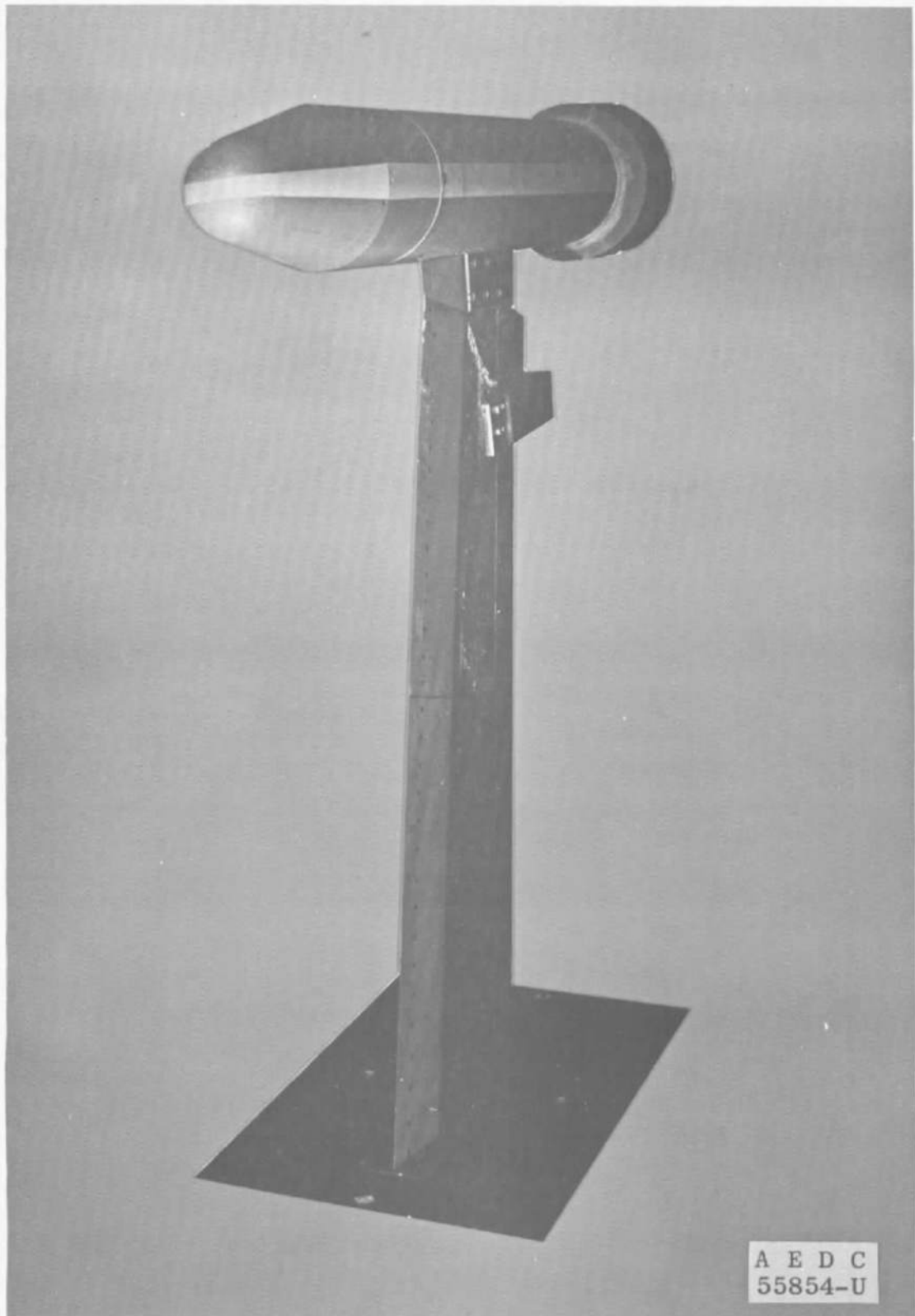

Fig. 3 Installation of Full-Scale Model Centerbody in Test Section

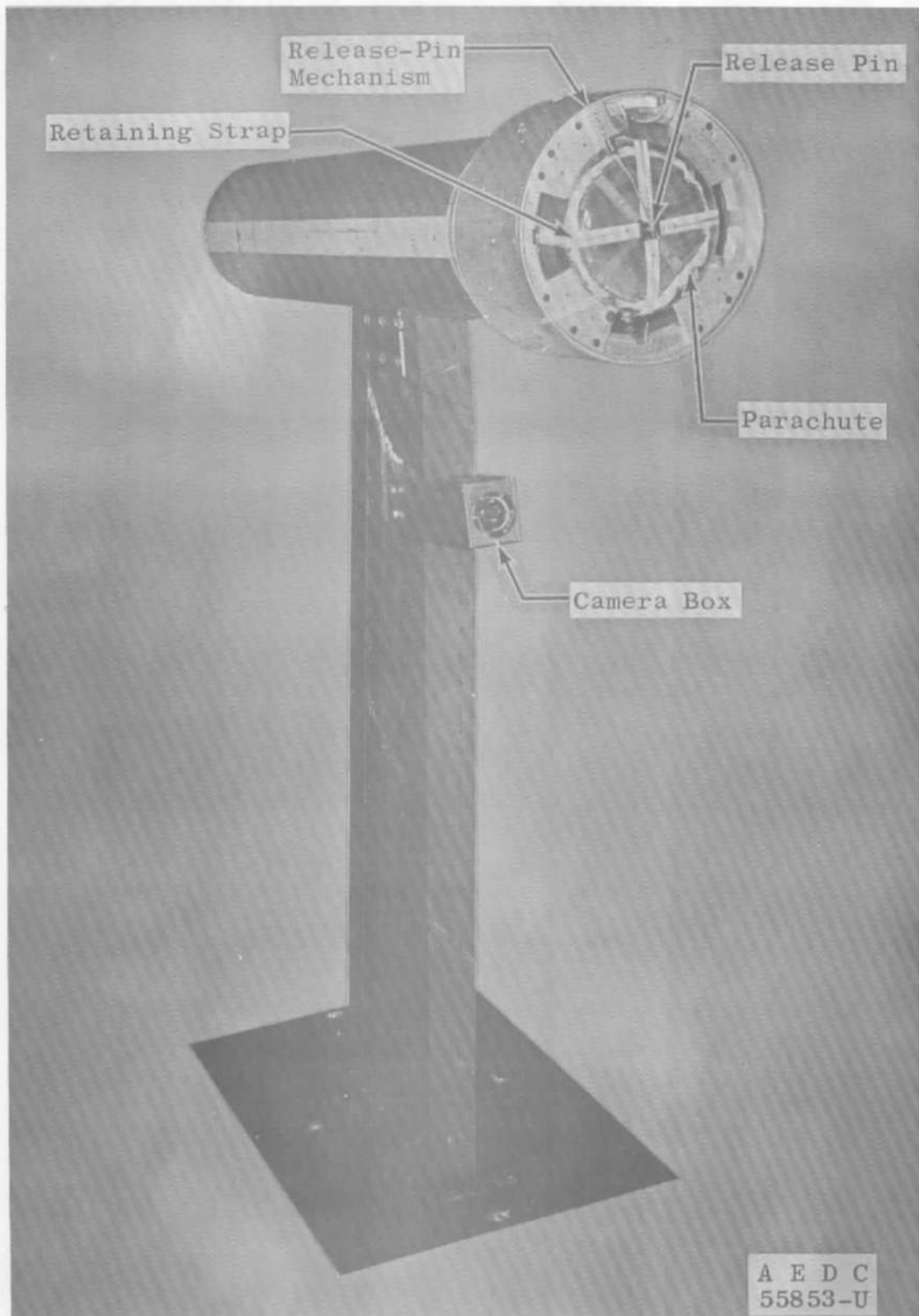
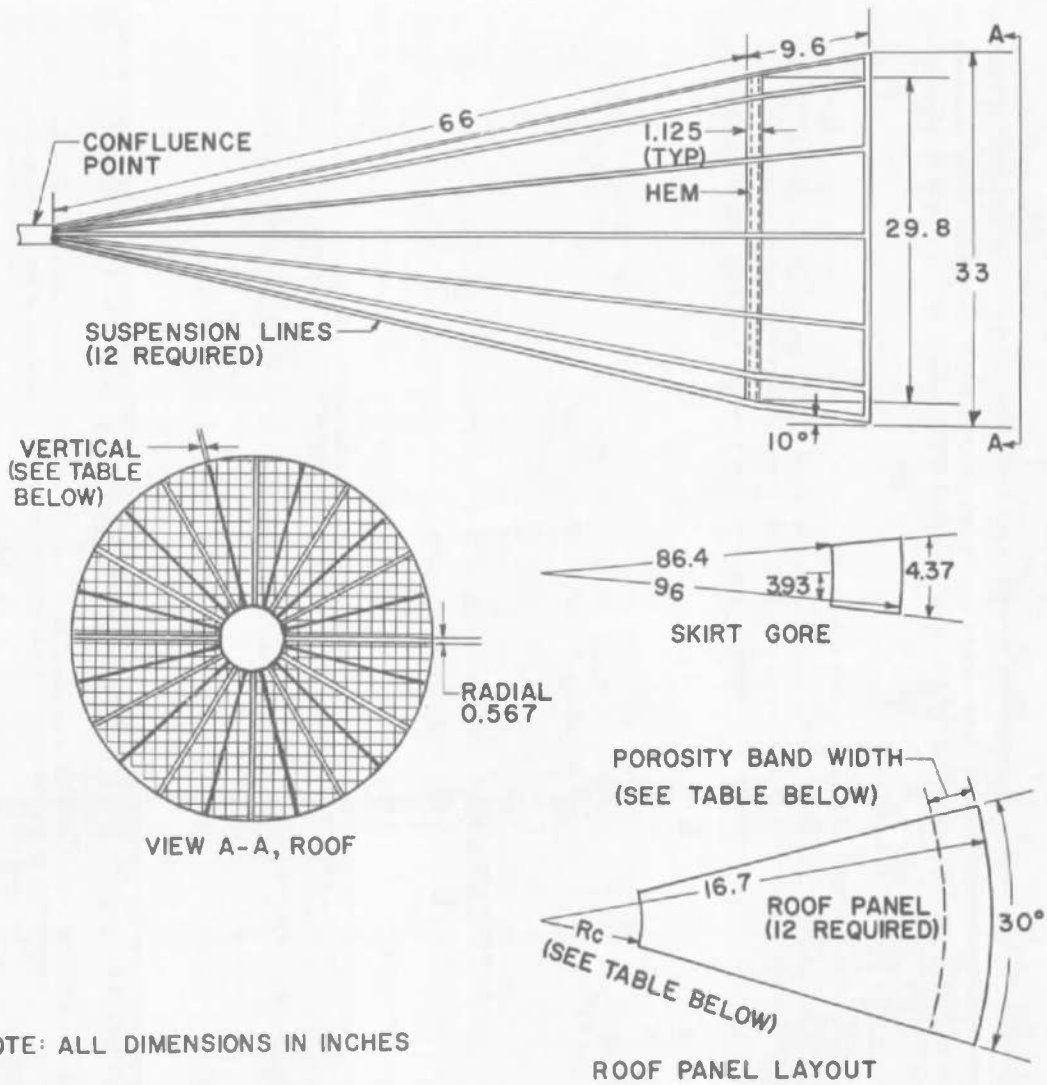

Fig. 4 Three-Quarter Rear View of Model Centerbody



NOTE: ALL DIMENSIONS IN INCHES

PARACHUTE CONFIGURATION	CAP RADIUS R_c	POROSITY BANDWIDTH	VERTICAL WIDTH
1	3.25	NONE	0.375
2	10.30	3.3	"
3	3.20	NONE	"
4	10.00	3.2	"
5	10.75	4.1	"
15	3.00	NONE	0.567

Fig. 5 Hyperflo Parachute Details, Configurations 1 through 5 and Configuration 15

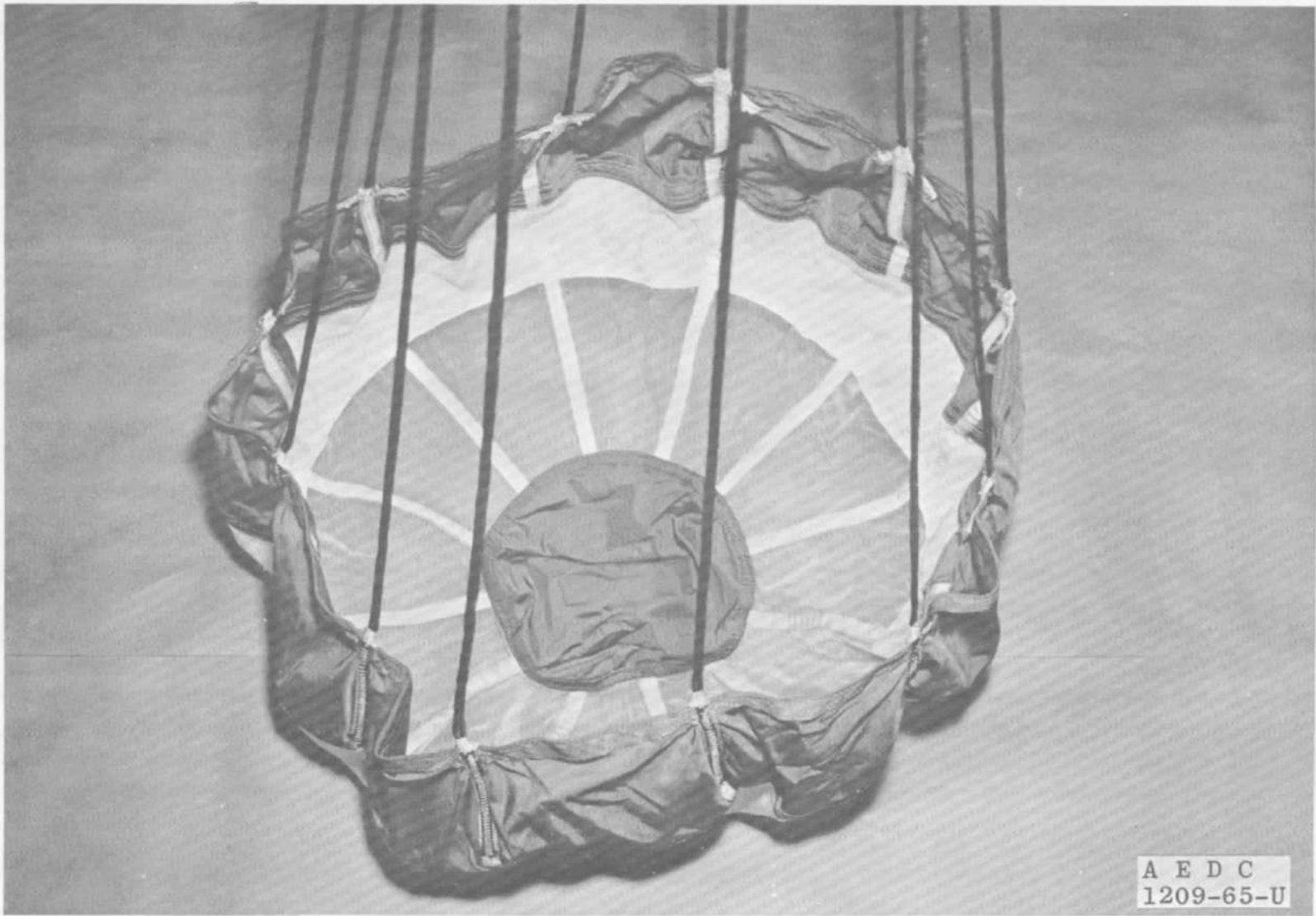

Fig. 6 Hyperflo Parachute

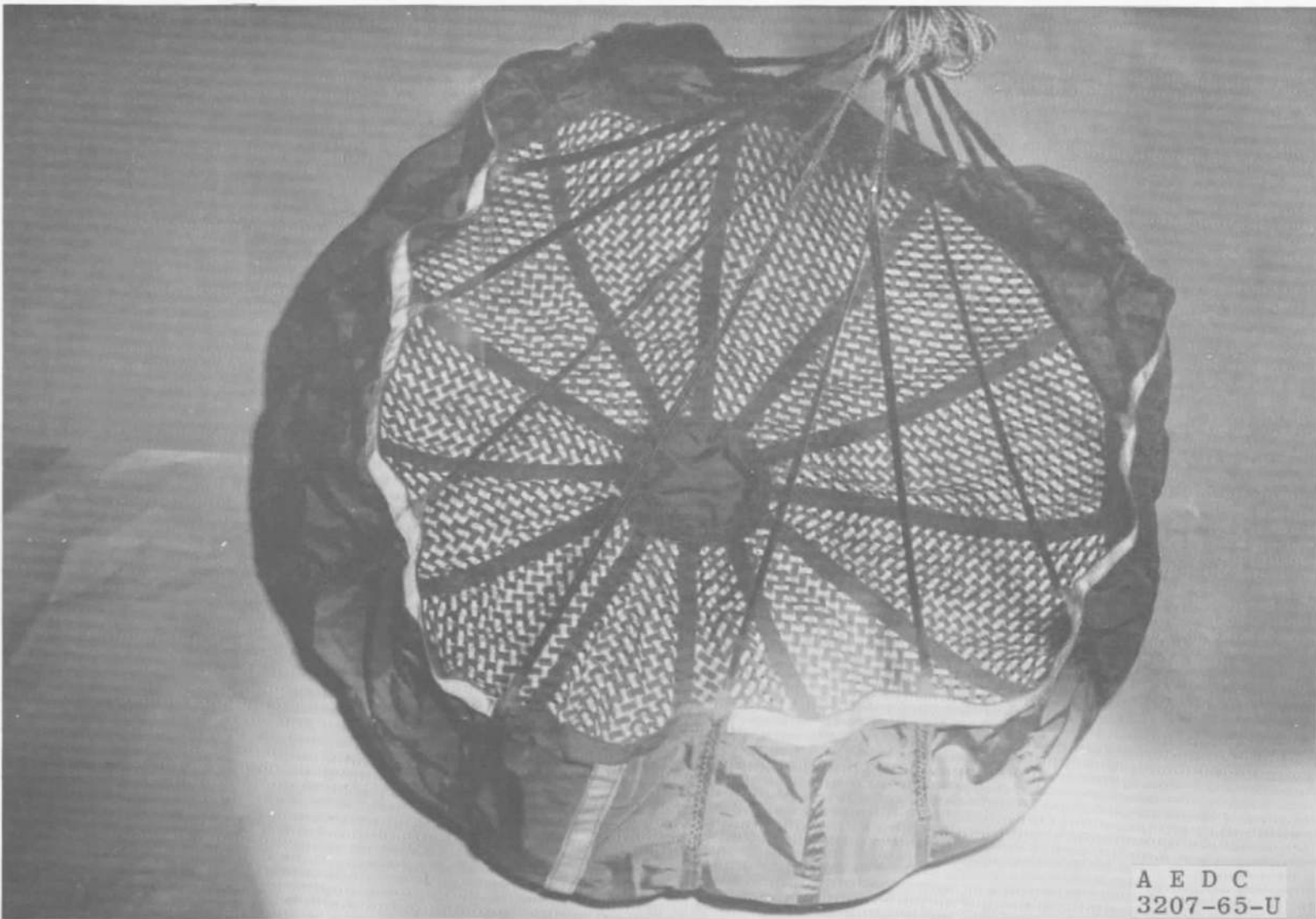

Fig. 7 Configuration 15, with Quarter-Inch Webbing Mesh Roof

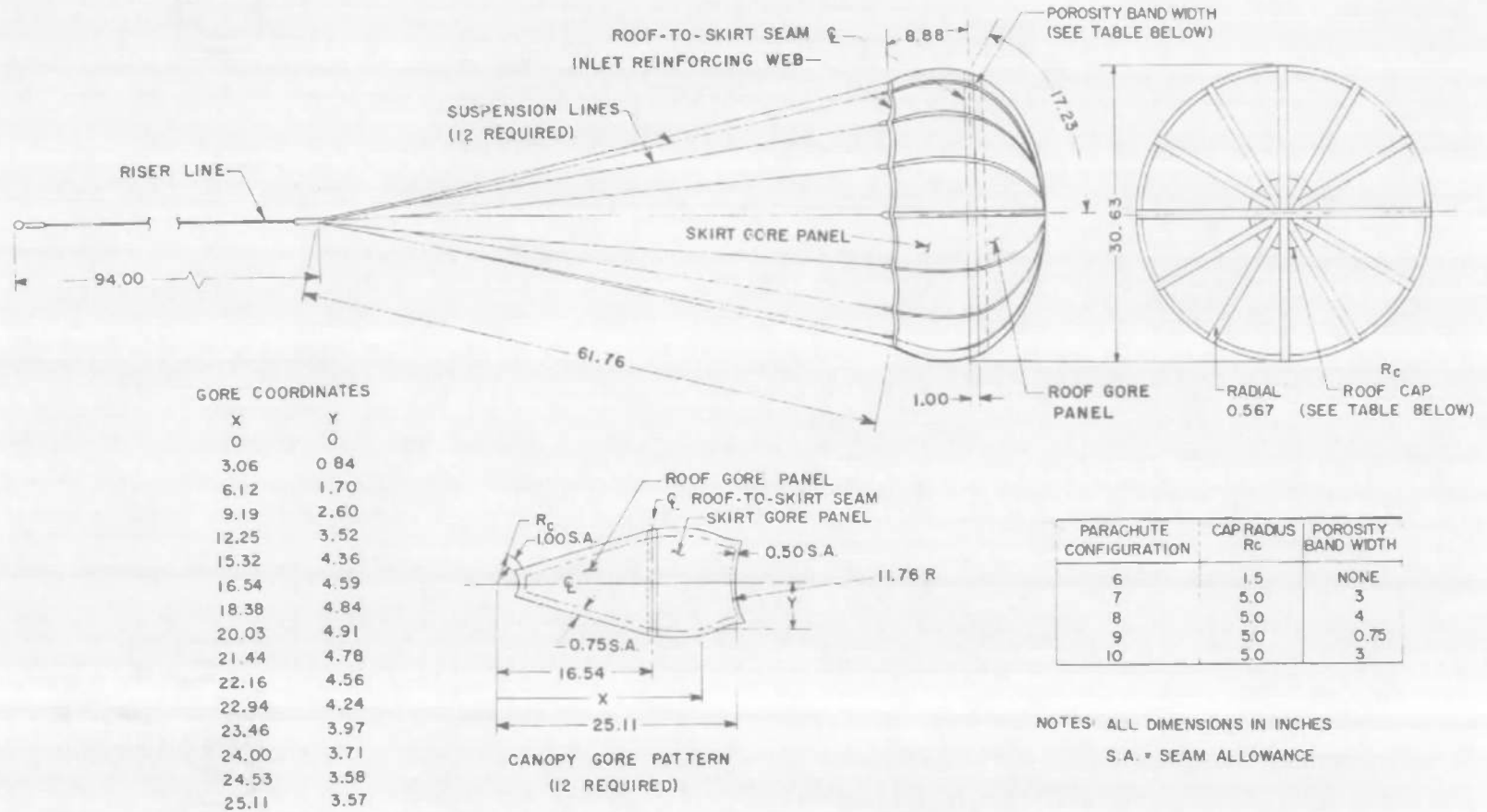
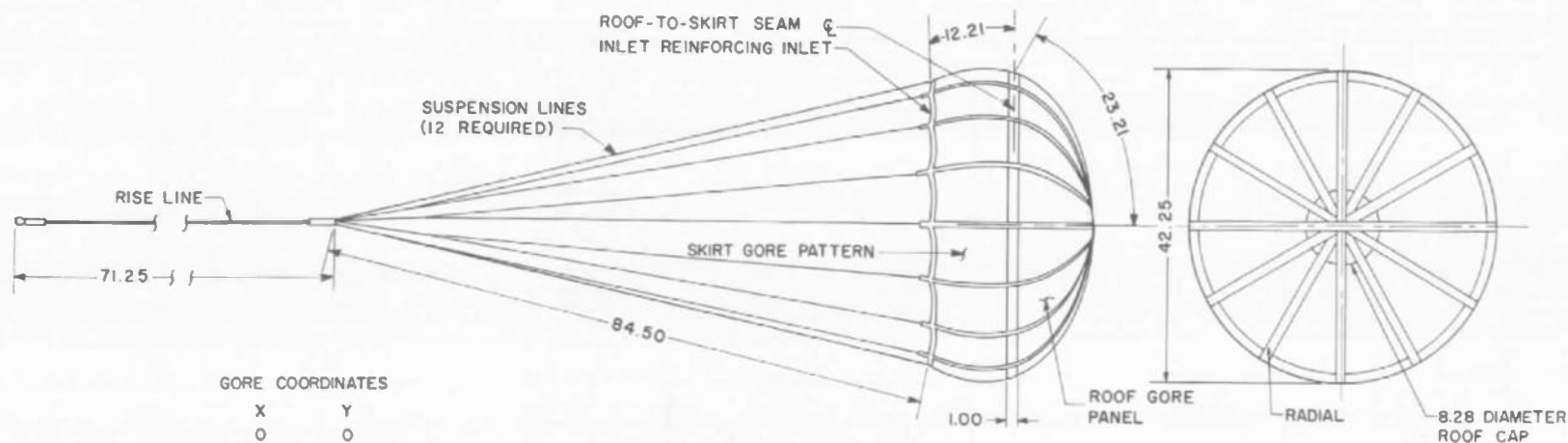
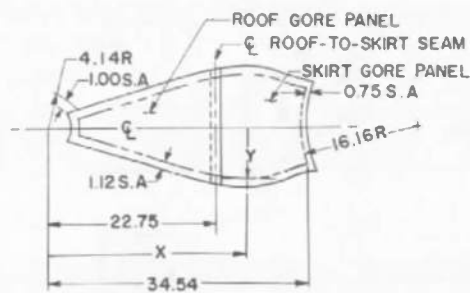

Fig. 8 Parasonic Parachute Details, Configurations 6 through 10



GORE COORDINATES

X	Y
0	0
1.05	0.28
2.12	0.59
4.21	1.16
6.32	1.75
8.43	2.34
10.52	2.95
12.62	3.58
14.76	4.21
16.85	4.84
18.95	5.43
21.30	6.00
22.75	6.31
23.16	6.38
25.26	6.65
27.56	6.76
29.50	6.64
30.45	6.27
31.55	5.83
32.30	5.46
33.00	5.10
33.70	4.92
34.54	4.90



NOTES: ALL DIMENSIONS IN INCHES
S.A = SEAM ALLOWANCE

Fig. 9 Parasonic Parachute Details, Configurations 11 and 12

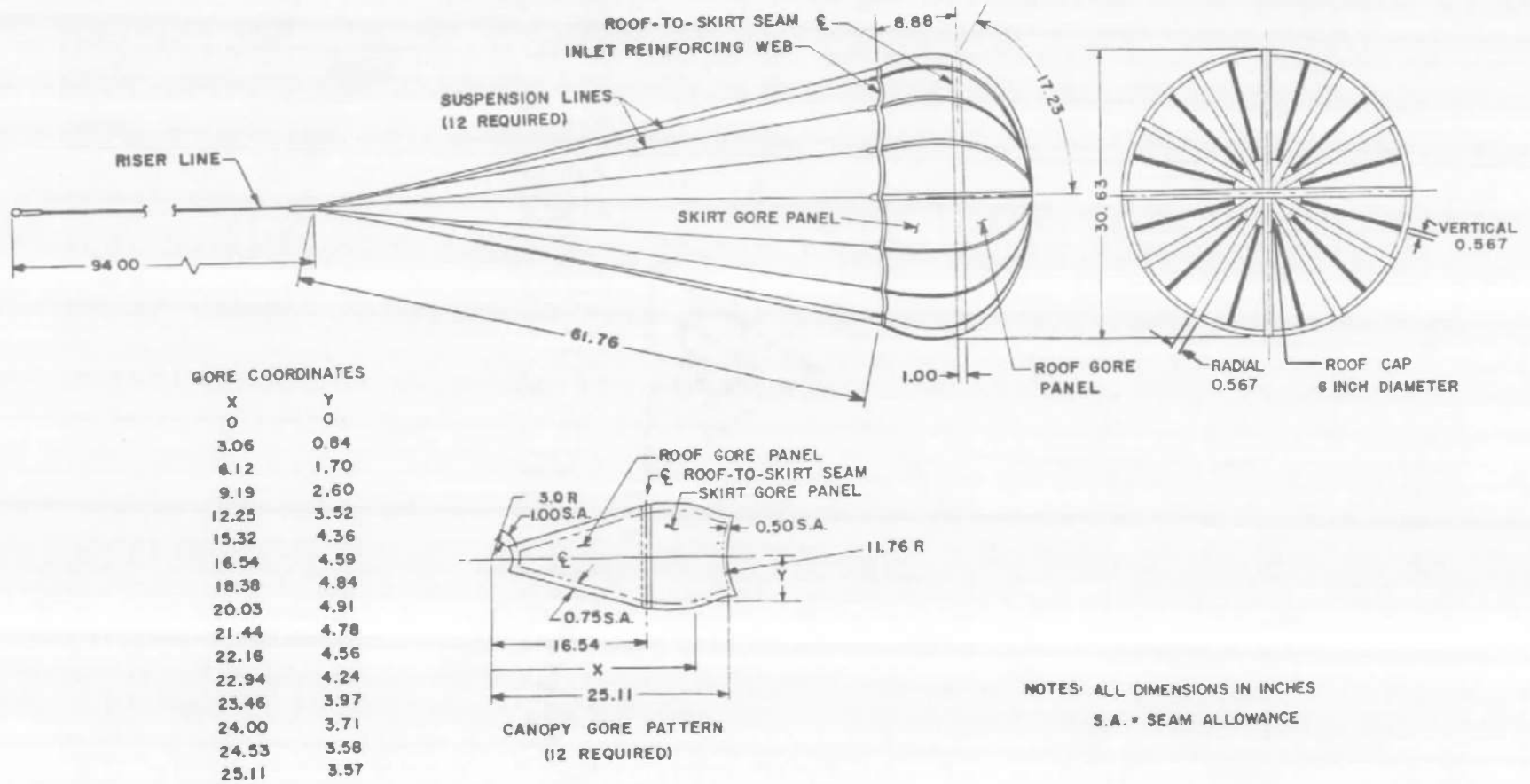

Fig. 10 Parasonic Parachute Details, Configuration 14

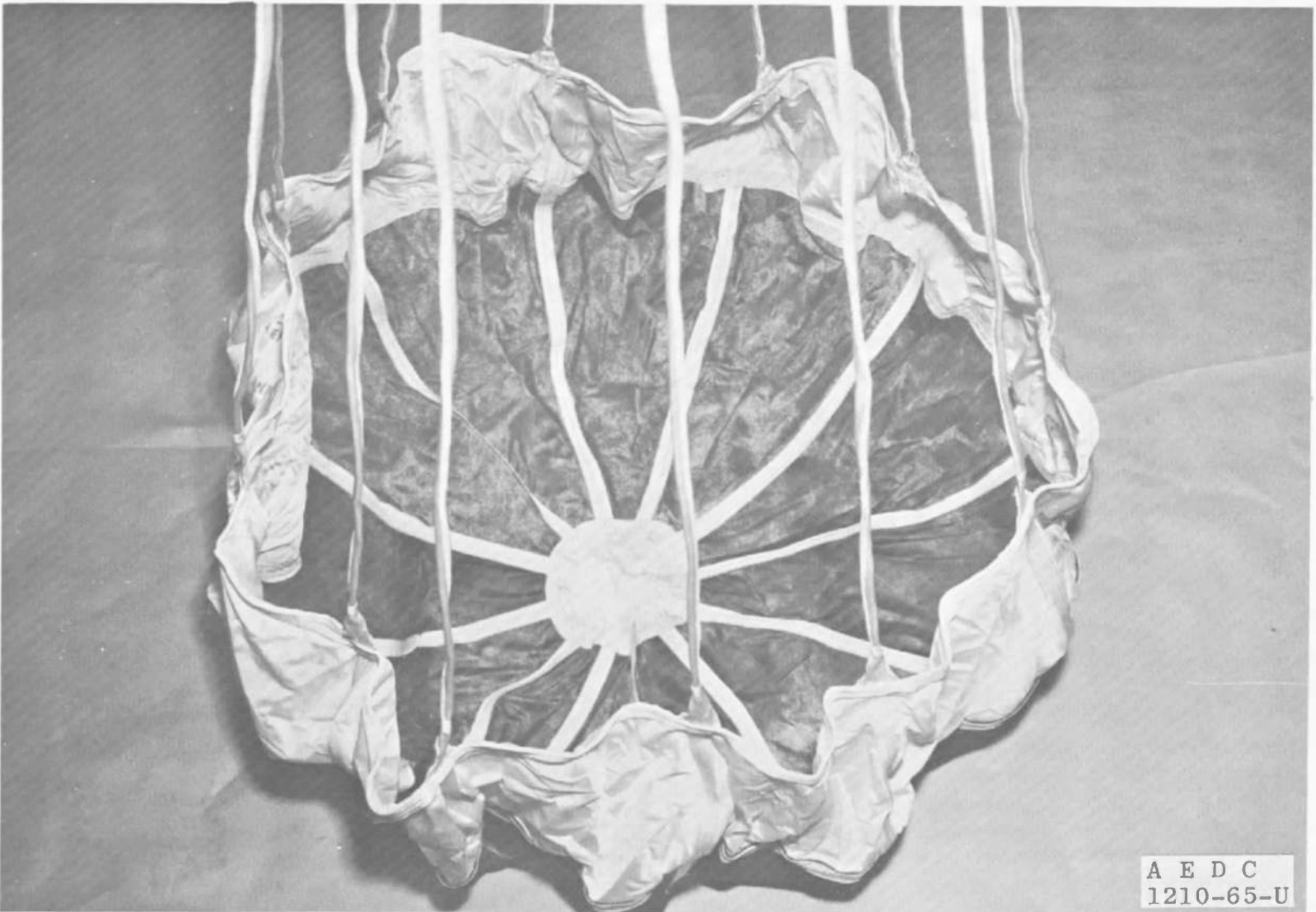
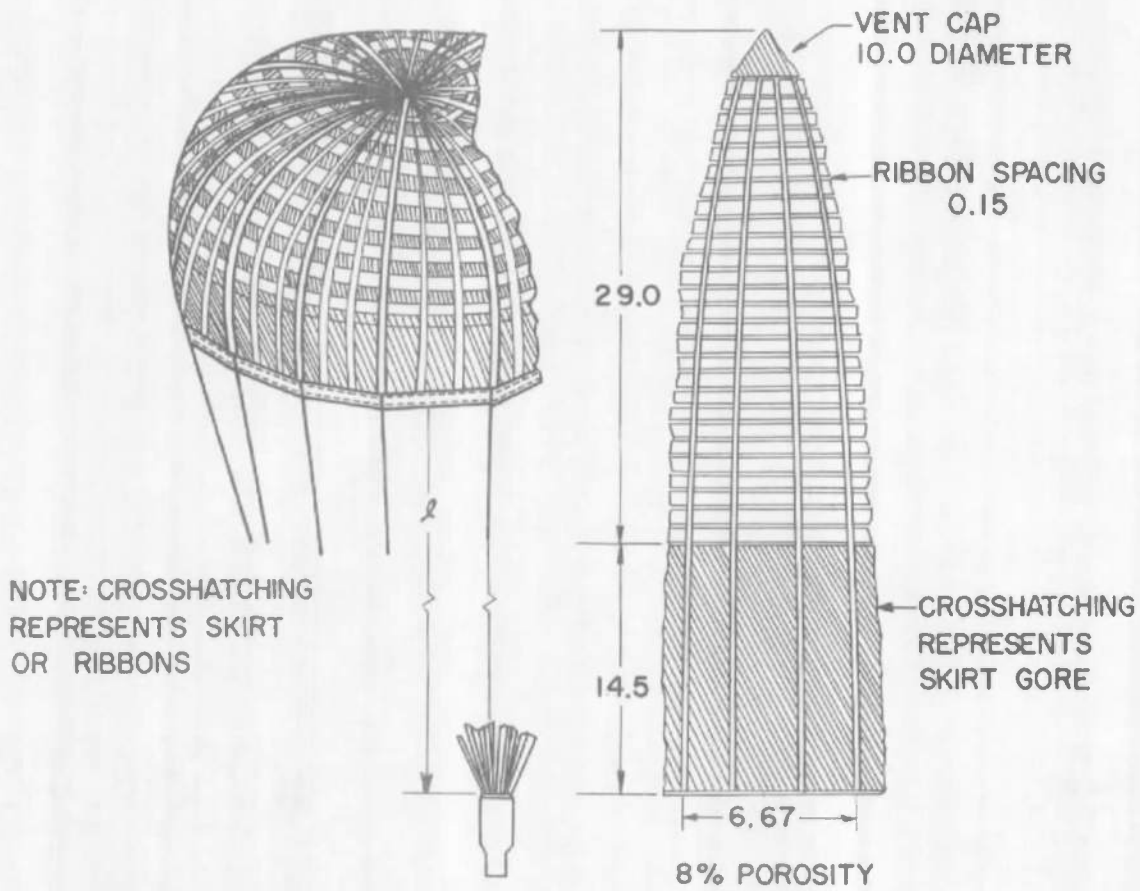

Fig. 11 Parasonic Parachute



HEMISFLO RIBBON
 RIBBON WIDTH, 0.75 INCH
 20 GORES
 72 IN. NOMINAL DIAMETER
 SUSPENSION LINE LENGTH, $l = 144$ INCHES
 SUSPENSION LINE WIDTH, 0.563 INCH

NOTE: ALL DIMENSIONS IN INCHES

Fig. 12 Hemisflo Parachute Details, Configuration 13

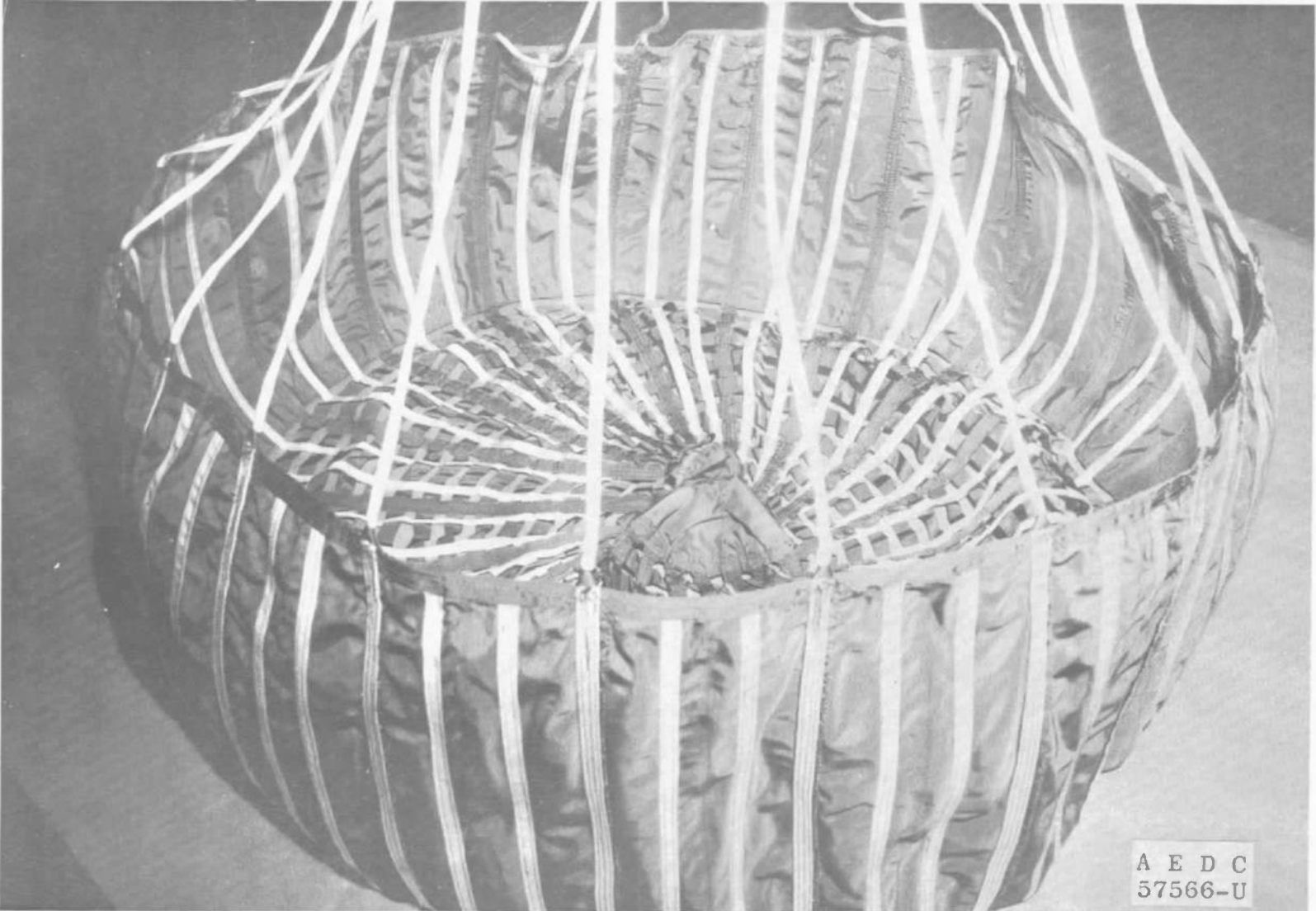
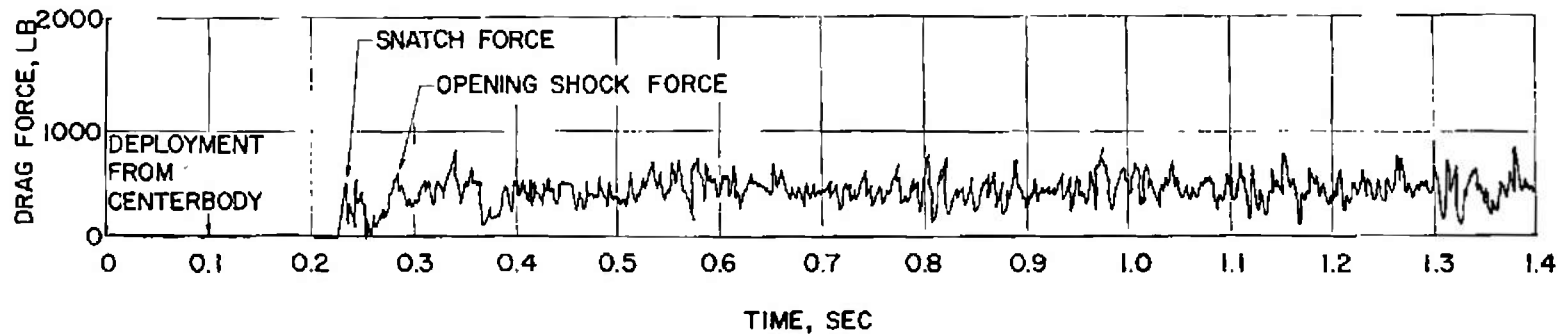
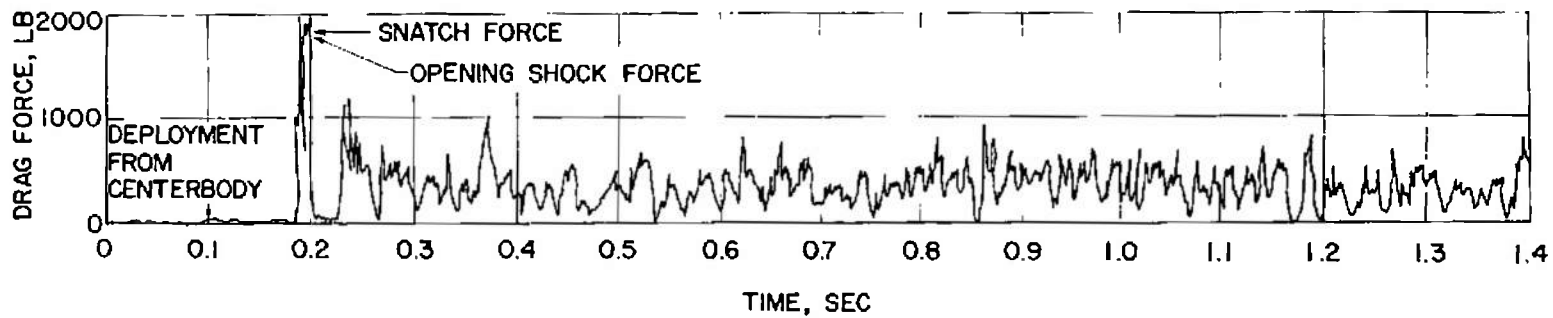

Fig. 13 Hemisflo Parachute



a. Configuration 1



b. Configuration 2

Fig. 14 Parachute Deployment Characteristics

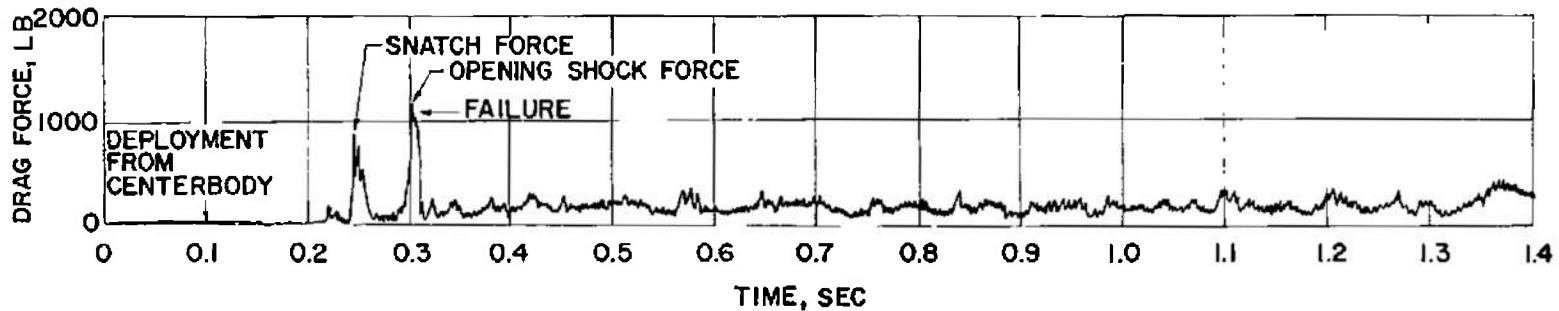

c. Configuration 3

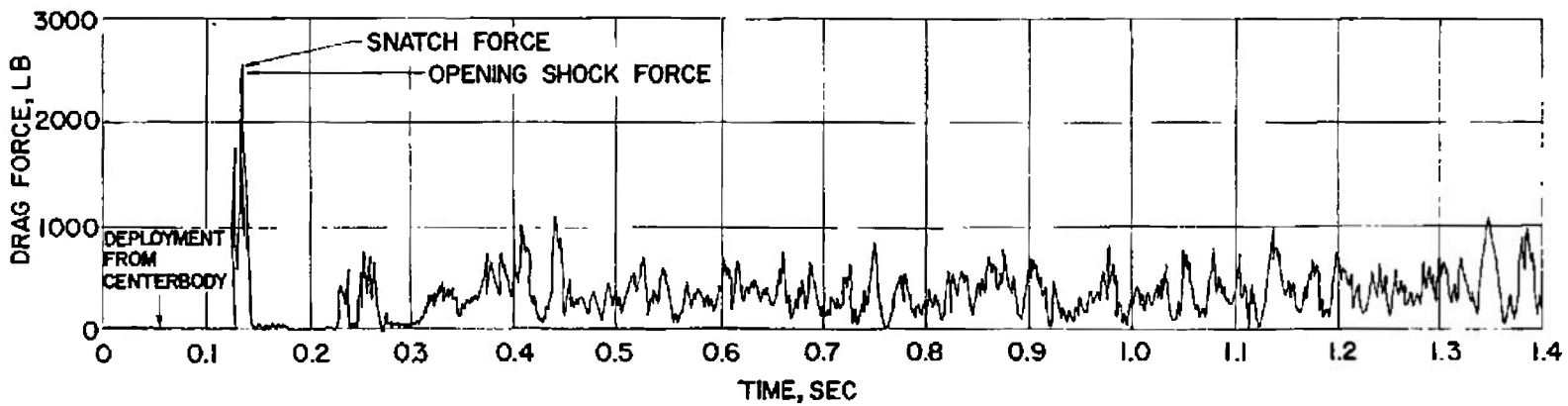

d. Configuration 4

Fig. 14 Continued

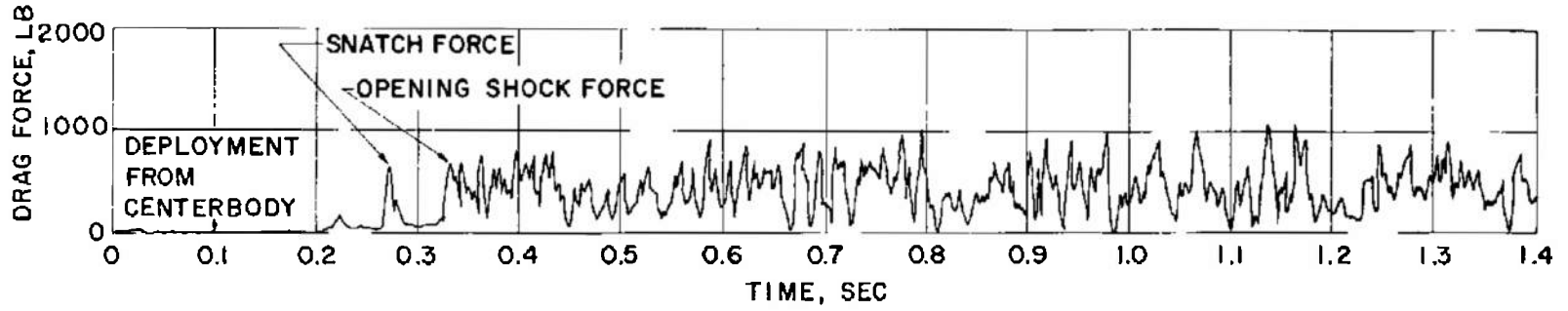

e. Configuration 5

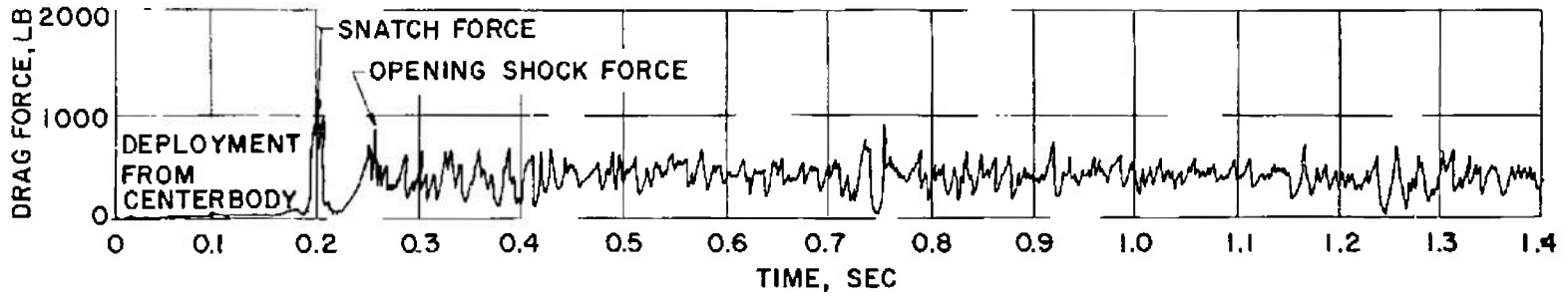

f. Configuration 6

Fig. 14 Continued

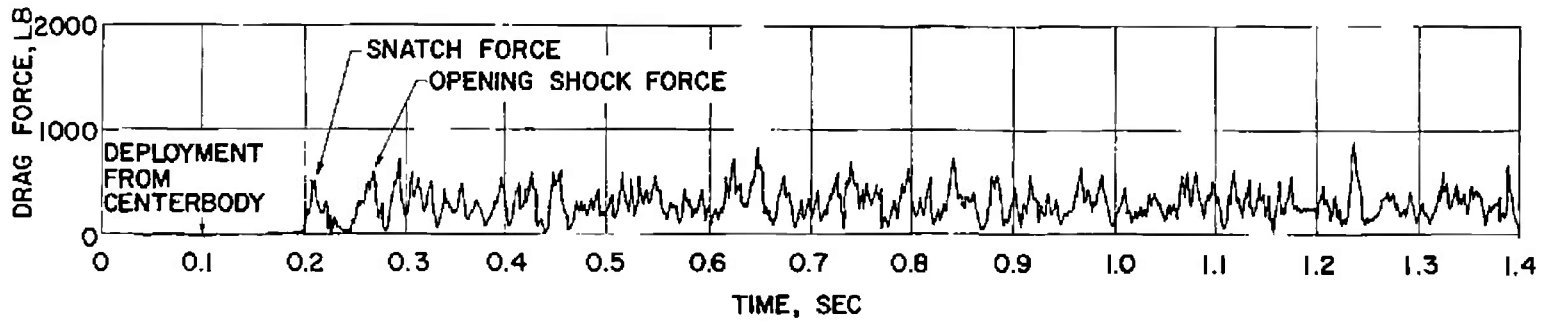

g. Configuration 7

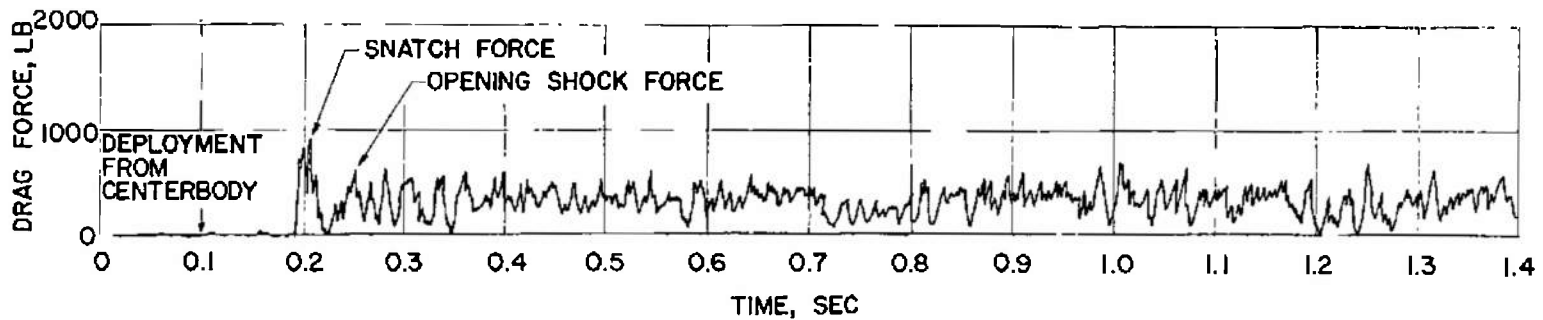

h. Configuration 8

Fig. 14 Continued

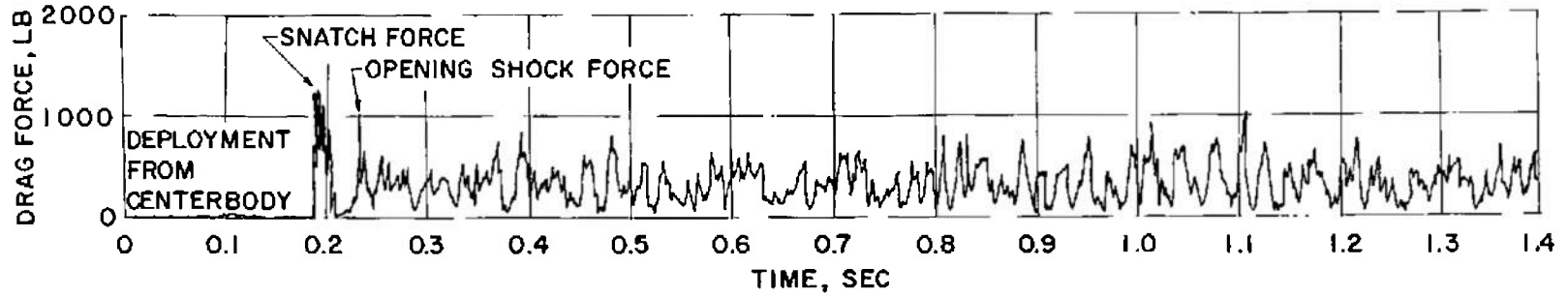

i. Configuration 9

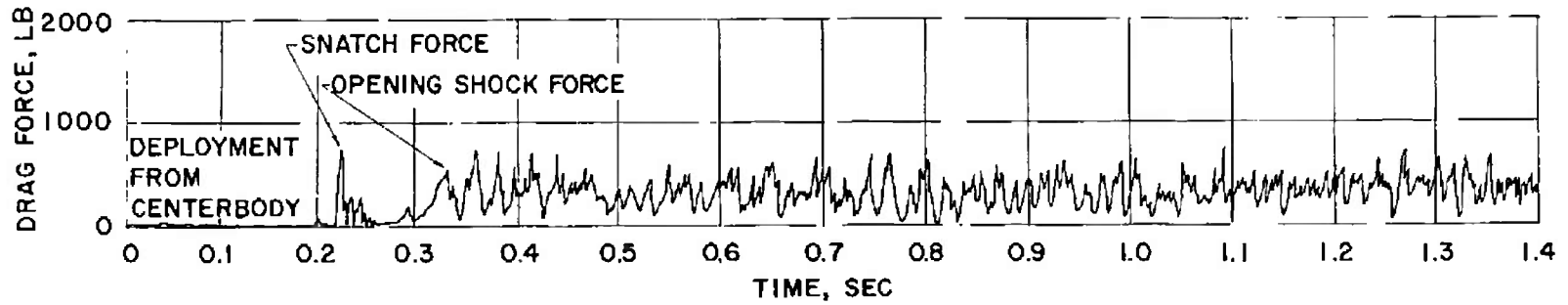

j. Configuration 10

Fig. 14 Continued

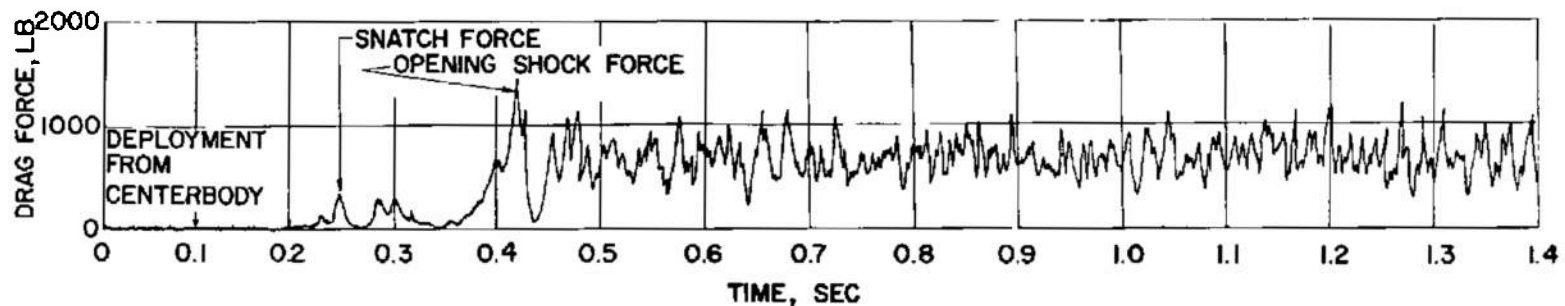

k. Configuration 11

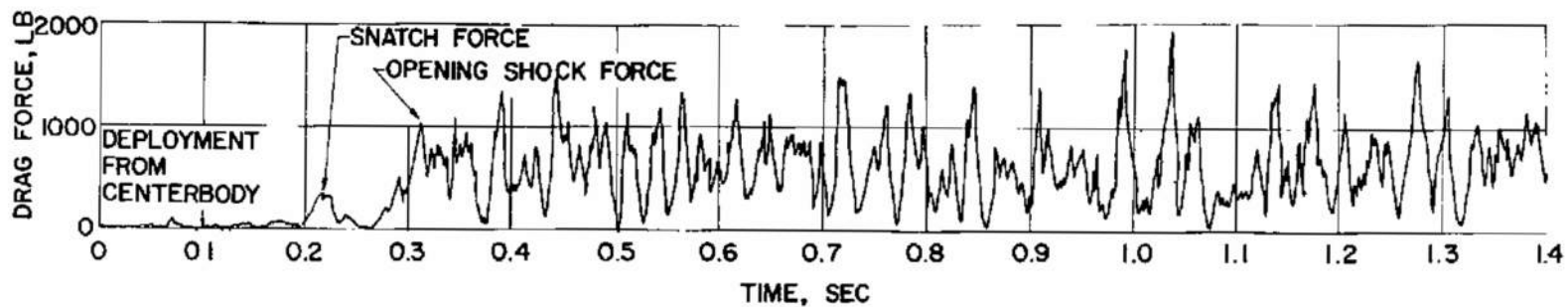

l. Configuration 12

Fig. 14 Continued

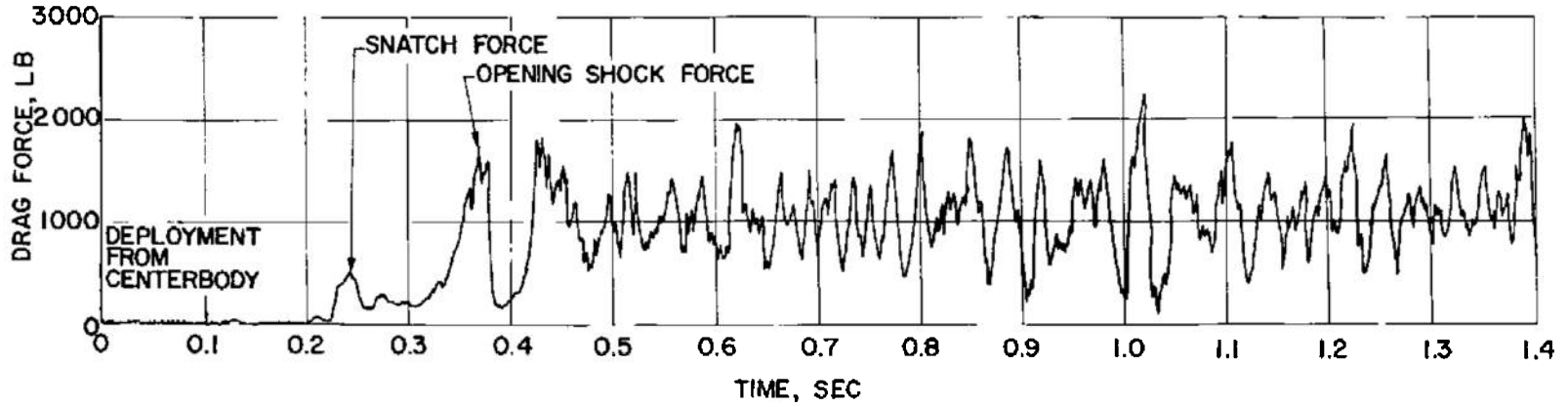

m. Configuration 13

Fig. 14 Continued

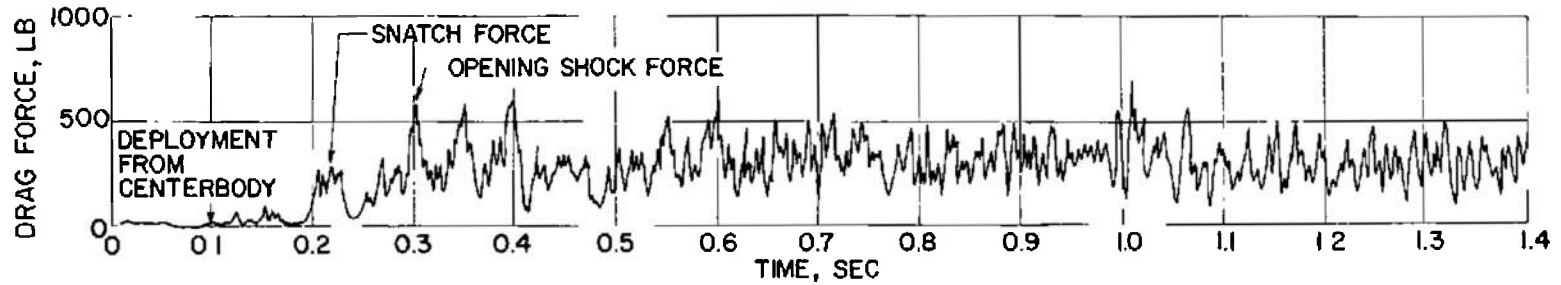

n. Configuration 14

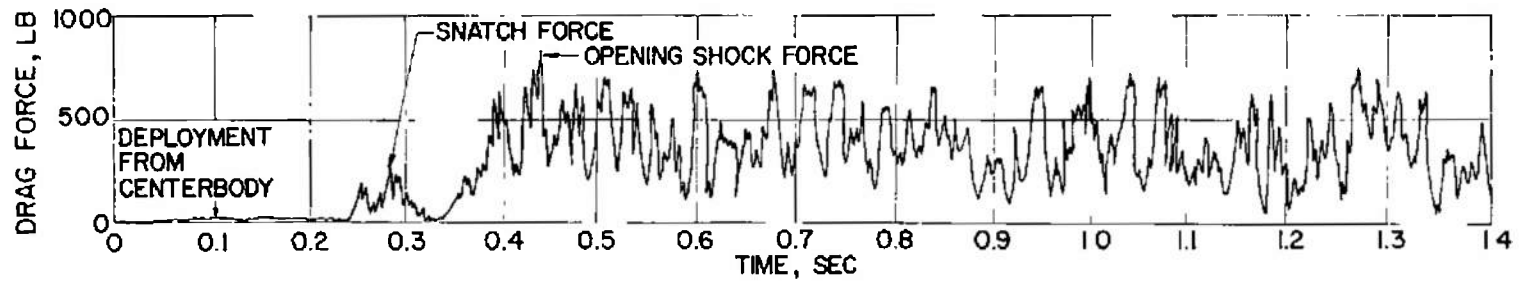

o. Configuration 15

Fig. 14 Concluded

TABLE I
SUMMARY OF PARACHUTE DETAILS

<u>Parachute Configuration</u>	<u>Type</u>	<u>Parachute Nominal Diameter, ft</u>	<u>Parachute Porosity, percent</u>	<u>Area Ratio, A_i/A_e</u>	<u>Strength of Roof Material, lb/in. of width</u>	<u>Number of Threads Per Lineal Inch in Parachute Roof Material</u>	<u>Type of Material</u>
1	Hyperflo	4.00	8.23	4.75	25	280 x 280	Nylon skirt, Perlon mesh roof
2	Hyperflo	4.00	10.50	4.50	49	230 x 230	Nylon skirt, Perlon mesh roof
3	Hyperflo	4.00	10.50	4.50	30	230 x 230	Nylon skirt, nylon mesh roof
4	Hyperflo	4.00	10.50	4.50	54	137 x 137	Nylon skirt, nylon mesh roof
5	Hyperflo	4.00	10.50	4.50	65	64 x 64	Nylon skirt, Perlon mesh roof
6	Parasonic	4.00	8.00	4.10	25	280 x 280	Nylon skirt, Perlon mesh roof
7	Parasonic	4.00	9.30	3.50	49	230 x 230	Nylon skirt, Perlon mesh roof
8	Parasonic	4.00	9.30	3.50	30	230 x 230	Nylon skirt, nylon mesh roof
9	Parasonic	4.00	9.30	3.50	54	137 x 137	Nylon skirt, nylon mesh roof
10	Parasonic	4.00	9.30	3.50	65	64 x 64	Nylon skirt, Perlon mesh roof
11	Parasonic	5.50	5.30	6.57	260	322 x 353	Nylon skirt, nylon mesh roof
12	Parasonic	5.50	5.30	6.57	260	322 x 353	Nylon skirt, nylon mesh roof
13	Hemisflo	6.00	8.00	5.00	--	--	Solid nylon skirt, nylon ribbon roof
14	Parasonic	4.00	4.60	6.00	320	--	Nylon skirt, 0.25-in. cotton webbing mesh roof
15	Hyperflo	4.00	5.60	7.00	320	--	Nylon skirt, 0.25-in. cotton webbing mesh roof

TABLE II
PARACHUTE TEST CONDITIONS AND RESULTS

Config- uration	M_∞	q_∞ , psfa	Parachute Nominal Diameter, ft	Canopy Porosity, percent	X, ft	C_{D0}	Parachute Stability Characteristics	
							Maximum Angle of Oscillation about Base Attachment Point \pm deg	Average Frequency of Oscillation About Base Attach- ment Point, cps
1	3.00	119.8	4.00	8.23	12.5	0.286	6.5	4.0
2	3.00	119.5	4.00	10.50	12.5	0.248	12.0	4.0
3*	3.00	119.7	4.00	10.50	12.5	--	--	--
4	3.00	119.5	4.00	10.50	12.5	0.231	12.5	4.5
5	3.00	120.2	4.00	10.50	12.5	0.261	13.0	4.0
6	3.00	120.2	4.00	8.00	12.5	0.267	4.5	3.0
7	3.00	119.5	4.00	9.30	12.5	0.210	8.0	4.0
8	3.00	119.5	4.00	9.30	12.5	0.250	5.0	3.0
9	3.00	120.3	4.00	9.30	12.5	0.220	12.0	2.5
10	3.00	120.4	4.00	9.30	12.5	0.230	7.5	2.0
11	3.00	120.1	5.50	5.30	12.5	0.229	4.0	2.0
12	3.00	119.5	5.50	5.30	12.5	0.211	14.5	3.5
13	3.00	120.1	6.00	8.00	12.5	0.304	8.5	2.5
14	3.00	120.0	4.00	4.60	12.5	0.262	3.5	4.0
14	2.80	120.0	4.00	4.60	12.5	0.280	2.5	3.5
14	2.60	120.0	4.00	4.60	12.5	0.280	2.5	3.0
15	3.00	120.0	4.00	5.60	12.5	0.285	7.0	3.0

*Failed on deployment

DOCUMENT CONTROL DATA - R&D

(Security classification of title, body of abstract and indexing annotation must be entered when the overall report is classified)

1 ORIGINATING ACTIVITY (Corporate author) Arnold Engineering Development Center ARO, Inc., Operating Contractor Arnold AF Station, Tennessee		2a REPORT SECURITY CLASSIFICATION UNCLASSIFIED	
		2b GROUP N/A	
3 REPORT TITLE INVESTIGATION OF VARIOUS FULL-SCALE PARACHUTES AT MACH NUMBER 3.0			
4 DESCRIPTIVE NOTES (Type of report and inclusive dates) N/A			
5 AUTHOR(S) (Last name, first name, initial) Reichenau, David E. A., ARO, Inc.			
6 REPORT DATE December 1965		7a TOTAL NO OF PAGES 36	7b NO OF REFS 1
8a CONTRACT OR GRANT NO AF 40(600)-1200		9a ORIGINATOR'S REPORT NUMBER(S) AEDC-TR-65-241	
b PROJECT NO. 6065		9b OTHER REPORT NO(S) (Any other numbers that may be assigned this report) N/A	
c Program Element 62405364		d	
10 AVAILABILITY/LIMITATION NOTICES Qualified users may obtain copies of this report from DDC. Release to CFSTI and foreign announcement and distribution are not authorized.			
11 SUPPLEMENTARY NOTES N/A		12 SPONSORING MILITARY ACTIVITY Air Force Flight Dynamics Laboratory Air Force Systems Command Wright-Patterson AFB, Ohio	
13 ABSTRACT Several hyperflo and parasonic parachutes and one hemisflo parachute were tested in the 16-ft supersonic wind tunnel to obtain drag, inflation, and stability characteristics at a nominal Mach number of 3.0 and a nominal free-stream dynamic pressure of 120 psfa. The effects of various types of roof mesh and material on the aerodynamic characteristics of the parachutes were obtained. These data show that the hyperflo parachutes had higher drag loads but less inflation and stability than the corresponding parasonic parachutes with the same combination of roof mesh and material. Differences in roof designs resulted in a drag variation of approximately 25 percent for both the hyperflo and parasonic series of 4-ft nominal diameter parachutes.			

This document has been approved for public release
its distribution is unlimited. Per AF Letter
dated 16 October 1974,
Signed William O. Cole

14 KEY WORDS	LINK A		LINK B		LINK C	
	ROLE	WT	ROLE	WT	ROLE	WT
decelerators parachutes hyperflo hemisflo parasonic supersonic flow wind tunnel tests drag characteristics static stability inflation characteristics roof design, parachute						

INSTRUCTIONS

1. **ORIGINATING ACTIVITY:** Enter the name and address of the contractor, subcontractor, grantee, Department of Defense activity or other organization (*corporate author*) issuing the report.
- 2a. **REPORT SECURITY CLASSIFICATION:** Enter the overall security classification of the report. Indicate whether "Restricted Data" is included. Marking is to be in accordance with appropriate security regulations.
- 2b. **GROUP:** Automatic downgrading is specified in DoD Directive 5200.10 and Armed Forces Industrial Manual. Enter the group number. Also, when applicable, show that optional markings have been used for Group 3 and Group 4 as authorized.
3. **REPORT TITLE:** Enter the complete report title in all capital letters. Titles in all cases should be unclassified. If a meaningful title cannot be selected without classification, show title classification in all capitals in parenthesis immediately following the title.
4. **DESCRIPTIVE NOTES:** If appropriate, enter the type of report, e.g., interim, progress, summary, annual, or final. Give the inclusive dates when a specific reporting period is covered.
5. **AUTHOR(S)** Enter the name(s) of author(s) as shown on or in the report. Enter last name, first name, middle initial. If military, show rank and branch of service. The name of the principal author is an absolute minimum requirement.
6. **REPORT DATE:** Enter the date of the report as day, month, year, or month, year. If more than one date appears on the report, use date of publication.
- 7a. **TOTAL NUMBER OF PAGES:** The total page count should follow normal pagination procedures, i.e., enter the number of pages containing information.
- 7b. **NUMBER OF REFERENCES:** Enter the total number of references cited in the report.
- 8a. **CONTRACT OR GRANT NUMBER:** If appropriate, enter the applicable number of the contract or grant under which the report was written.
- 8b, 8c, & 8d. **PROJECT NUMBER:** Enter the appropriate military department identification, such as project number, subproject number, system numbers, task number, etc.
- 9a. **ORIGINATOR'S REPORT NUMBER(S):** Enter the official report number by which the document will be identified and controlled by the originating activity. This number must be unique to this report.
- 9b. **OTHER REPORT NUMBER(S):** If the report has been assigned any other report numbers (*either by the originator or by the sponsor*), also enter this number(s).
10. **AVAILABILITY/LIMITATION NOTICES:** Enter any limitations on further dissemination of the report, other than those

imposed by security classification, using standard statements such as:

- (1) "Qualified requesters may obtain copies of this report from DDC."
- (2) "Foreign announcement and dissemination of this report by DDC is not authorized."
- (3) "U. S. Government agencies may obtain copies of this report directly from DDC. Other qualified DDC users shall request through _____."
- (4) "U. S. military agencies may obtain copies of this report directly from DDC. Other qualified users shall request through _____."
- (5) "All distribution of this report is controlled. Qualified DDC users shall request through _____."

If the report has been furnished to the Office of Technical Services, Department of Commerce, for sale to the public, indicate this fact and enter the price, if known.

11. **SUPPLEMENTARY NOTES:** Use for additional explanatory notes.
12. **SPONSORING MILITARY ACTIVITY:** Enter the name of the departmental project office or laboratory sponsoring (*paying for*) the research and development. Include address.
13. **ABSTRACT:** Enter an abstract giving a brief and factual summary of the document indicative of the report, even though it may also appear elsewhere in the body of the technical report. If additional space is required, a continuation sheet shall be attached.

It is highly desirable that the abstract of classified reports be unclassified. Each paragraph of the abstract shall end with an indication of the military security classification of the information in the paragraph, represented as (TS), (S), (C), or (U).

There is no limitation on the length of the abstract. However, the suggested length is from 150 to 225 words.

14. **KEY WORDS:** Key words are technically meaningful terms or short phrases that characterize a report and may be used as index entries for cataloging the report. Key words must be selected so that no security classification is required. Identifiers, such as equipment model designation, trade name, military project code name, geographic location, may be used as key words but will be followed by an indication of technical context. The assignment of links, rules, and weights is optional.