

UNCLASSIFIED

AD NUMBER
AD474534
NEW LIMITATION CHANGE
TO Approved for public release, distribution unlimited
FROM Distribution authorized to U.S. Gov't. agencies and their contractors; Administrative/Operational Use; 07 OCT 1965. Other requests shall be referred to Chemical Research and Development Labs., Edgewood Arsenal, MD.
AUTHORITY
USAEA ltr, 13 Nov 1968

THIS PAGE IS UNCLASSIFIED

SECURITY

MARKING

The classified or limited status of this report applies to each page, unless otherwise marked.

Separate page printouts MUST be marked accordingly.

THIS DOCUMENT CONTAINS INFORMATION AFFECTING THE NATIONAL DEFENSE OF THE UNITED STATES WITHIN THE MEANING OF THE ESPIONAGE LAWS, TITLE 18, U.S.C., SECTIONS 793 AND 794. THE TRANSMISSION OR THE REVELATION OF ITS CONTENTS IN ANY MANNER TO AN UNAUTHORIZED PERSON IS PROHIBITED BY LAW.

NOTICE: When government or other drawings, specifications or other data are used for any purpose other than in connection with a definitely related government procurement operation, the U. S. Government thereby incurs no responsibility, nor any obligation whatsoever; and the fact that the Government may have formulated, furnished, or in any way supplied the said drawings, specifications, or other data is not to be regarded by implication or otherwise as in any manner licensing the holder or any other person or corporation, or conveying any rights or permission to manufacture, use or sell any patented invention that may in any way be related thereto.

AD

REPORT NO. TO-B 65-90

474534
HOLOGRAM CAMERA AND RECONSTRUCTION
SYSTEM FOR ASSESSMENT OF EXPLOSIVELY
GENERATED AEROSOLS

Final Report

by

William R. Zinky

7 October 1965

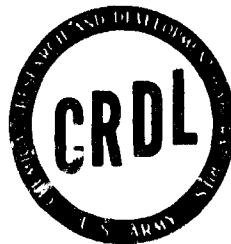

DOC
DEC 6 1965

**US Army Edgewood Arsenal
CHEMICAL RESEARCH AND DEVELOPMENT LABORATORIES
Edgewood Arsenal, Maryland 21010**

Contract No. DA-18-035-AMC-256(A)

**Technical Operations Research
Burlington, Massachusetts**

Defense Documentation Center Availability Notice

Qualified requesters may obtain copies of this report from
Defense Documentation Center, Cameron Station, Alexandria,
Virginia 22314

FINAL REPORT
HOLOGRAM CAMERA AND RECONSTRUCTION SYSTEM
FOR ASSESSMENT OF EXPLOSIVELY GENERATED AEROSOLS

Contract No. DA 18-035-AMC-256(A)

by

William R. Zinky

Report No. TO-B 65-90

7 October 1965

Submitted to

U. S. Army Chemical Research
and Development Laboratories
Edgewood Arsenal
Edgewood Arsenal, Maryland

FOREWORD

The work described in this report (TO-B 65-90) was performed by Technical Operations Research for the U. S. Army Chemical Research and Development Laboratories under Contract No. DA 18-305-AMC-256(A).

Acknowledgments

The author wishes to acknowledge the efforts of the several scientists and engineers who contributed to the research reported. The fundamental studies and demonstration of the feasibility of the hologram process were carried out by Dr. Brian J. Thompson and Dr. George B. Parrent. Important experimental and theoretical contributions were made by John H. Ward and Bruce Justh. The major portion of the detailed mechanical design was contributed by James P. King. In addition, the skill and diligence of the test chamber support group at Edgewood Arsenal made an effective test program possible under difficult environmental conditions.

Notices

Reproduction of this document in whole or in part is prohibited except with permission of US Army Edgewood Arsenal Chemical Research and Development Laboratories; however, DDC is authorized to reproduce the the document for United States Government purposes.

The information in this report has not been cleared for release to the general public.

Disclaimer

The findings in this report are not to be construed as an official Department of the Army position, unless so designated by other authorized documents.

Disposition

When this document has served its purpose, DESTROY it.

ABSTRACT

This report describes the design and synthesis of a hologram camera and reconstruction system for measuring particle sizes in the 3 to 1000- μ range in explosively generated aerosols. The objective was to measure a volume of high velocity particles in situ. Theoretical resolution requirements and design details concerning 10 camera configurations with magnifications from 1 to 25X, capable of resolving particles from 3.5 to 1000 μ , are discussed. The design of a laser collimator to provide a 20 nsec illumination source is described. Aerosol sample volumes from 6.75 mm³ to 256 cm³ were reconstructed from individual photographs. Recommendations for further refinement of this working system are included.

PREVIOUS PAGES WERE BLANK, THEREFORE NOT FILMED

TABLE OF CONTENTS

<u>Chapter</u>		<u>Page</u>
1	INTRODUCTION	1
	SUMMARY OF OBJECTIVE	1
	HOLOGRAMS	1
	FRAUNHOFER (FAR-FIELD) HOLOGRAMS	2
2	HOLOGRAM RECORDING SYSTEM COMPONENTS	6
3	LASER LIGHT SOURCE	9
	LASER OPERATION	9
	GENERAL DESCRIPTION	9
	Q-SWITCH OPERATION	9
	OUTPUT POWER AND PULSE CHARACTERISTICS	12
	INSPECTION AND ALIGNMENT	15
	LASER BEAM COLLIMATOR AND LASER LIGHT TUBE	17
4	HOLOGRAM CAMERA APPARATUS AND CONTROL UNIT	19
	GENERAL DESCRIPTION	19
5	HOLOGRAM CAMERA SYSTEM	25
	RESOLUTION REQUIREMENTS AND SPECIFICATIONS	25
	LENSLESS HOLOGRAM SYSTEM	25
	Spatial and Temporal Coherence Effects on Resolution: Determination of Picture Volume	26
	COMBINING LENS SYSTEMS AND HOLOGRAM SYSTEMS	30
	Frequency Response for Particle Size Edge Detail	31
	SYSTEM DESIGN: SELECTION OF OPTIMUM CHARACTERISTICS	33
6	FILMS FOR HOLOGRAM PHOTOGRAPHY	34
7	FLASH FILTER	38

TABLE OF CONTENTS (Cont'd.)

<u>Chapter</u>		<u>Page</u>
8	RECONSTRUCTION SYSTEM	39
	GENERAL DESCRIPTION	39
	COMPONENTS	41
	RECONSTRUCTION SOURCE	41
	COLLIMATOR	41
	MECHANICAL SCANNER	41
9	FIELD INSTALLATION	44
10	STANDARDIZATION PROCEDURE	47
11	DYNAMIC TEST RESULTS	51
12	CONCLUSIONS AND RECOMMENDATIONS	57
	CONCLUSIONS	57
	RECOMMENDATIONS	59
	REFERENCES	62

LIST OF ILLUSTRATIONS

<u>Figure</u>		
1	Recording and Reconstruction of Fraunhofer Holograms	3
2	Hologram Camera and Laser Light Source	6
3	Block Diagram of Hologram Recording System	7
4	Laser Optical Configuration	10
5	Energy Level Diagram for Q-Switch	11
6	Q-Switch Absorption Versus Time	11
7	Variation of Allowable Velocity Versus Particle Diameter	14

LIST OF ILLUSTRATIONS (Cont'd.)

<u>Figure</u>		<u>Page</u>
8	Pulse Length Monitor	14
9	Laser Alignment	16
10	Camera and Accessories	19
11	Camera Magazine and Shutter Actuator	19
12	Camera Assembly	20
13	Camera Control Unit	24
14	Circuit Diagram: Camera Control Unit	24
15	Geometry of Hologram Formation	27
16	Frequency Components for Edge Detail	32
17	Hologram Reconstruction System	40
18(a)	Scanner Assembly	42
18(b)	Reconstruction Scanner with Television Readout	43
19	Edgewood: Laser Camera Installation	45
20	Hologram Reconstruction of Standard Particles	49
21	Hologram Reconstruction of Standard Particles	50
22	Dynamic Hologram Reconstruction	52
23	Static Hologram Reconstruction	53
24	Reconstruction: Debris in Expanding Cloud	54
25	Reconstruction: Water Plume in Liquid Dispersion Test	54
26	Hologram: Shock Waves	55
27	Dynamic Hologram Reconstruction	56

LIST OF TABLES

<u>Table</u>		<u>Page</u>
1	Hologram Camera Performance Characteristics	22
2	Film Characteristics and Processing Data	36

CHAPTER 1
INTRODUCTION

SUMMARY OF OBJECTIVE

The Physical Optics Department at Technical Operations Research has been engaged in developing the use of hologram techniques for particle size determination since early in 1963. Prototype instrumentation was developed for the Air Force under contract numbers, AF 19(604)-6661 and AF 19(628)-3313, resulting in successful measurements of naturally occurring fog. The purpose of the project that is described in this report was to extend these techniques and methods to design, fabricate, install, and test a hologram camera for the assessment of explosively generated aerosols at Edgewood Arsenal. This goal has been achieved, and the apparatus is currently being operated by Edgewood Arsenal personnel. Already, significant data have been obtained but have not, as yet, been fully studied and analyzed.

In this report we briefly discuss the Fraunhofer hologram and its relationship to other hologram techniques and then review the principle of the hologram technique for particle size determination. The major portion of the report is devoted to a detailed description of the hologram camera apparatus and its operation, and to a discussion of its potential in the light of significant preliminary results.

HOLOGRAMS

Since the initial discovery and work on holograms in 1948 by Gabor,¹ considerable advances in technique have come about due to the availability of light sources with increased temporal as well as spatial coherence. Both gas and ruby lasers have been employed in the formation of the hologram, and gas lasers have been used, almost exclusively, in the reconstruction process.

The hologram, or wave-front, reconstruction method is basically a two-step photographic imaging process. In Gabor's work, the hologram (word used by Gabor to describe the intermediate photographic record that consists of a diffraction pattern plus a coherent background) was formed by the interference between the diffracted radiation in the Fresnel region and the coherent background. Hence,

the term "Fresnel hologram" is used to distinguish it from the ones of interest in this report — the Fraunhofer (far-field) holograms.

In the Fresnel holograms investigated by Gabor^{2,3} and Rogers,⁴ the clarity of the reconstruction was limited by the troublesome virtual image. Following the work of Gabor, however, many investigators (E1-Sum,^{5,6} and Baez and E1-Sum,⁷ among others) directed their efforts towards removing the extraneous image. More recently, other workers, including Lohmann,⁸ Leith and Upatnieks,^{9,10,11} Vander Lugt,¹² and Stroke and Falconer,^{13,14,15} used a two-beam interferometer technique to produce an angular separation of the real and virtual images. Hence, the desired reconstructed image can be formed without the usual deterioration from the conjugate image. All of these workers used Fresnel holograms, and the subject is well covered in the literature including a number of popular articles (Scientific American,¹⁶ International Science and Technology,¹⁷).

The "Fraunhofer hologram" was introduced by Thompson²⁰ and is of particular importance since it provides the basis for a new and valuable technique in the particle size determining field as initially discussed by Thompson, et al.¹⁸⁻²² Further fundamental studies have been carried out by Reynolds²³ and DeVelis.²⁴ A summary of the principles of the hologram technique for particle size determination follows.

FRAUNHOFER (FAR-FIELD) HOLOGRAMS

A Fraunhofer diffraction pattern is strictly formed when the point of observation is infinitely distant from the illuminated object. Approximations to this situation are made by either the use of a lens or by making an approximation to infinity, the so-called far-field condition (see, e. g., Born and Wolf²⁵). It is the latter condition which is used here; i. e., the distance from the source to the diffracting aperture z' , and from the diffracting aperture to the plane of observation z , is such that

$$|z'| \gg \frac{(\xi^2 + \eta^2)_{\max}}{\lambda} \quad \text{and} \quad |z| \gg \frac{(\xi^2 + \eta^2)_{\max}}{\lambda}$$

where ξ and η are the coordinates of a general point in the diffracting aperture, and λ is the wavelength of the incident wave. If these conditions are satisfied, we define the hologram as a Fraunhofer, or far-field, hologram. This is not merely a trivial or semantic distinction; in fact, the second condition gives rise to an additional phase term that is fundamental to the reconstruction. A detailed analysis, both theoretical and experimental, of this process is given in Refs. 18 and 19; therefore, we shall only briefly outline here the basic principles involved.

In the formation process, the interference between the Fraunhofer diffraction from the object and the coherent quasi-monochromatic incident beam is recorded in the hologram plane (see Figure 1(a)). If the photographic process is correctly controlled, and the hologram is placed in the position shown in Figure 1(b), the amplitude transmission contains as its significant term a product of the Fourier transform of the object distribution with a factor that describes an effective Fresnel lens.

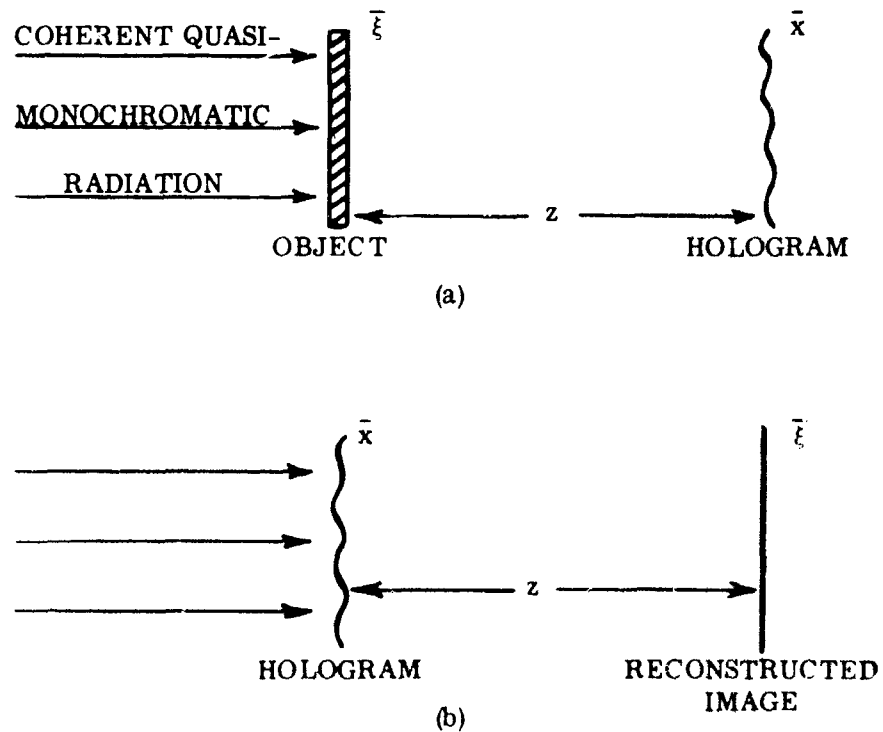

Figure 1. Recording and Reconstruction of Fraunhofer Holograms

The mathematical formulation of the problem can be stated as a boundary-value problem. Let a coherent, quasi-monochromatic plane wave-front be incident on a diffracting object whose amplitude distribution is described by $D(\bar{\xi})$, where $\bar{\xi}$ is the position vector in object space. (It is not essential that we limit ourselves to planar objects; in fact, some of the more interesting properties of holograms arise from the study of objects distributed in three dimensions. The limitation to plane waves for the incident radiation is also not necessary, but it simplifies the mathematics and serves to illustrate the essential features.) This diffraction problem can be solved to yield an intensity distribution $I(\bar{x})$ in the hologram recording plane given by

$$I(\bar{x}) \approx 1 - \frac{k}{\pi z} \tilde{D}\left(\frac{\bar{x}}{\lambda z}\right) \sin \frac{k\bar{x}^2}{2z} + \frac{k^2}{4\pi^2 z^2} \left[\tilde{D}\left(\frac{\bar{x}}{\lambda z}\right) \right]^2, \quad (1)$$

where \tilde{D} is the Fourier transform of the original object distribution, \bar{x} is the position vector in the recording plane, $k = \frac{2\pi}{\lambda}$ is the wave number, z is the distance from the diffracting object to the hologram recording plane, and λ is the wavelength of the light used. The second term in Eq. (1) involves the product of the amplitude associated with the Fraunhofer pattern of the object with a sine function which is independent of the size of the object. This term then represents the interference between the Fraunhofer diffraction from the object and the coherent background. Many examples and experimental verification of Eq. (1) are found in the literature.¹⁶⁻¹⁸

Examination of Eq. (1) shows that the first term is the largest, and the third, the smallest. If the gamma, γ , of the photographic process is properly controlled and the terms in $1/z^2$ are considered to be small compared to the background term, Eq. (1) can be expanded and the amplitude transmission, $t(\bar{x})$, in the hologram negative, is given by

$$t(\bar{x}) = 1 + \frac{\gamma k}{2\pi z} \tilde{D}\left(\frac{\bar{x}}{\lambda z}\right) \sin \frac{k\bar{x}^2}{2z}. \quad (2)$$

The reconstruction is accomplished, as indicated in Figure 1(b), by illuminating the hologram negative with a coherent quasi-monochromatic beam of light which again

is chosen to have a plane wave-front. (This restriction, as already pointed out, is not necessary; in addition, the wavelength need not be the same as that of the hologram forming radiation.)

Using the Sommerfeld method of Green's function, the intensity distribution in the reconstructed image can be expressed as

$$I(\bar{\xi}) = 1 + \gamma D(\bar{\xi}) + \frac{\gamma^2}{4} [D(\bar{\xi})]^2 . \quad (3)$$

This result indicates that the original object distribution is recovered.

In the following chapters, we shall discuss in detail the incorporation of these basic principles into a working system.

CHAPTER 2

HOLOGRAM RECORDING SYSTEM COMPONENTS

The hologram recording system consists of a Lear Siegler Model LS-100 laser light source, a laser light tube, and a camera, as shown in Figure 2.

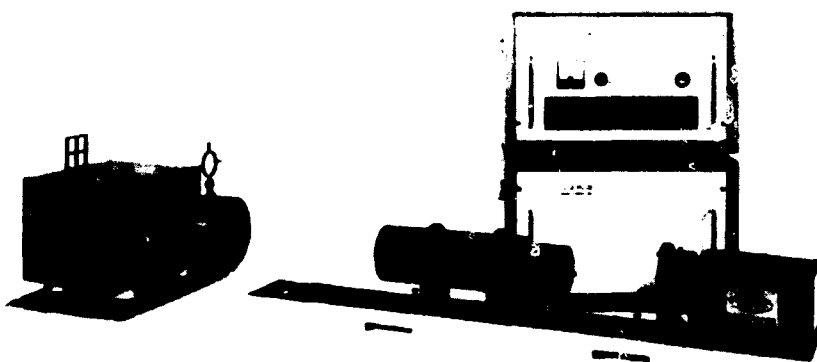

Figure 2. Hologram Camera and Laser Light Source

The camera is designed to be mounted inside an explosive test chamber within 1 ft of an explosive aerosol disseminator. The laser is mounted external to the chamber; the laser beam is collimated and directed to the picture volume through an 8-ft laser light tube. All components in this system are located on a common longitudinal axis. The picture volume is located immediately in front of the camera. Figure 3 is a block diagram of the hologram recording system.

Briefly, the function of the various system components is as follows. The laser generates a short, intense, quasi-monochromatic pulse of light. Two light stops prevent pump light and light from extraneous laser modes from entering the laser collimator. The laser collimator has the dual function of expanding the beam of light to cover the picture volume uniformly and of producing a spatially coherent field. A neutral density filter is used to vary the intensity of the collimated beam to control the exposure. The laser light tube provides a helium-filled, non-turbulent, non-scattering path for light to travel to the picture volume. The camera lens system records (on film) holograms of objects located in the picture volume. A flash filter located inside the camera allows passage of the laser light but absorbs the

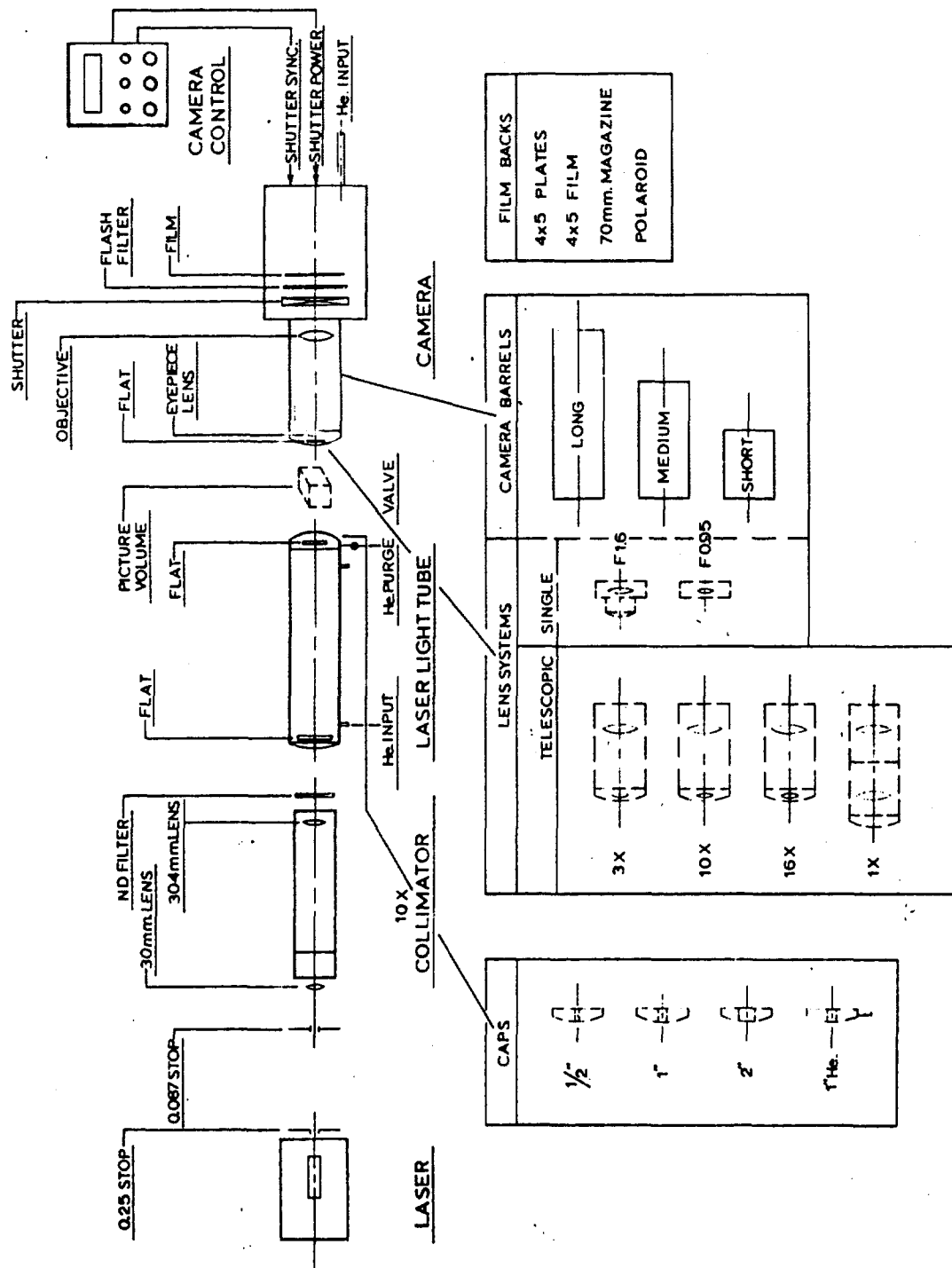

Figure 3. Block Diagram of Hologram Recording System

light from the explosive and most of the light that is generated by other auxiliary light sources. Glass flats protect the camera lens from the force and contamination of the blast. A camera control unit provides remote control and monitoring of the shutter and film magazine.

CHAPTER 3

LASER LIGHT SOURCE

LASER OPERATION

GENERAL DESCRIPTION

The light source for the camera consists of a pulsed ruby laser that has a peak output of 10 MW and a pulse duration of 20 nsec. Figure 4 shows the internal configuration of the laser. The active parts include: a ruby rod, a flash lamp, a total internal reflecting prism, a Uranyl glass Q-switch, and a sapphire partially-reflecting window that forms both ends of the folded resonant laser cavity. Thus, the light output from both ends of the ruby rod emerges from nearly the same spot on the sapphire window. The sapphire window is composed of two interferometrically spaced flats that reflect 66% of the incident energy at 6943 \AA . The reflectivity peaks are separated by approximately 1 \AA , which reduces the beam divergence from the ruby rod by a factor of three. The resulting output beam divergence is less than 1.5 mrad.

The ruby rod is $1/4$ in. in diameter and 3 in. long with the ends cut at the Brewster's angle. A helical flash lamp surrounds the ruby rod. The helical lamp, in turn, is surrounded by a rhodium plated cylindrical reflector.

The Uranyl glass Q-switch is placed in the resonant cavity between the sapphire flat and the ruby rod. The flash lamp couples energy to the ruby rod and to the Q-switch. The Q-switch is then pumped up to an energy level that depends on its coupling to the flash lamp. When the laser energy in the cavity reaches this level, the Q-switch becomes transparent and the sapphire flat will allow 34% of the energy in the resonant laser beam to become usable output.

Q-SWITCH OPERATION

The Q-switch is a solid state component that consists of a single piece of Uranyl glass. Figure 5 shows an energy level diagram.

Under ambient conditions, the Q-switch has essentially no absorption at the laser frequency. When the flash lamp is set off, however, the Q-switch is pumped to the metastable level where it can absorb photons at the ruby frequency. A typical absorption versus time curve is shown in Figure 6.

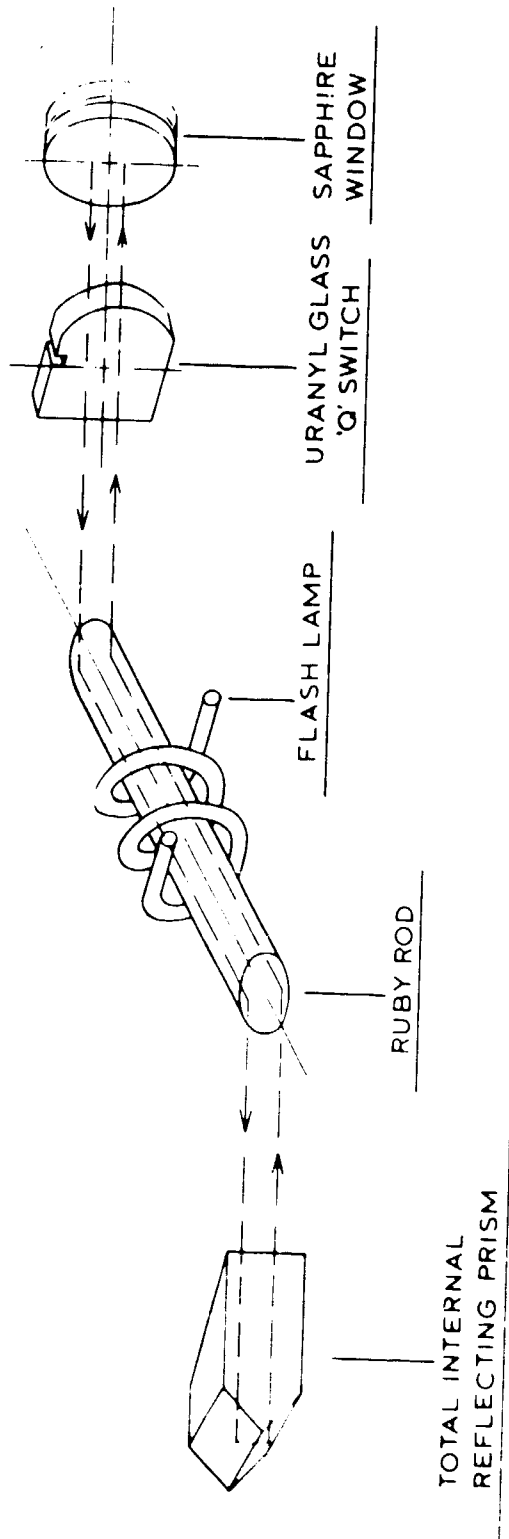

Figure 4. Laser Optical Configuration

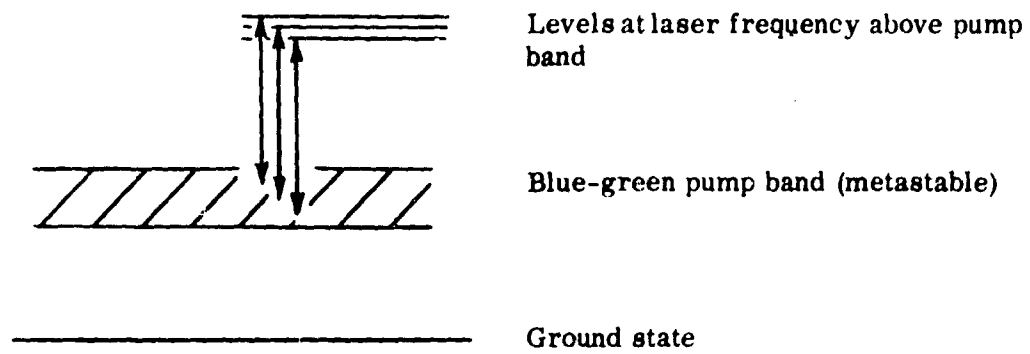

Figure 5. Energy Level Diagram for Q-Switch

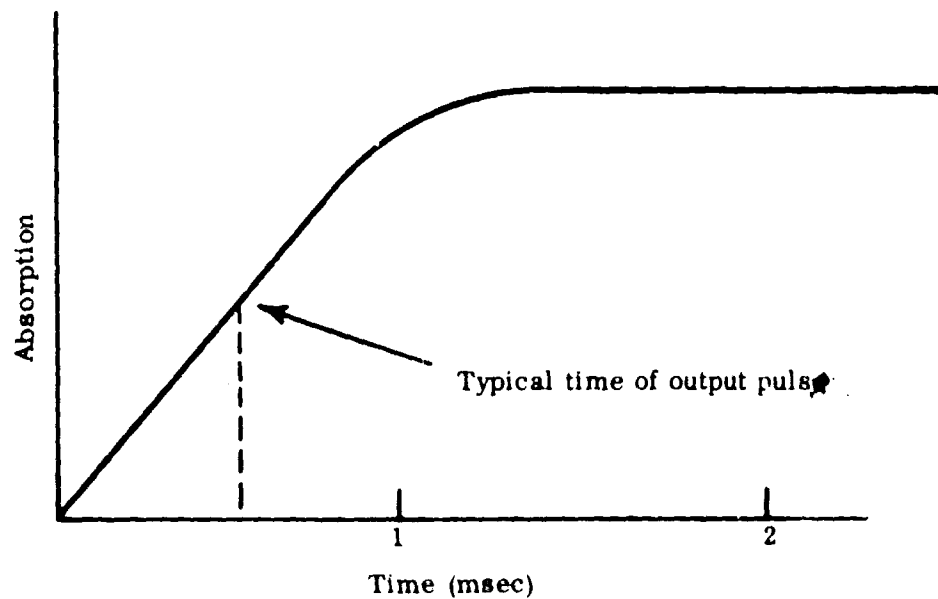

Figure 6. Q-Switch Absorption Versus Time

When the gain of the optical cavity overcomes the absorption, laser action occurs and the atoms in the metastable band are raised to higher levels by the absorption of photons at the laser frequency. These atoms then return to the ground state by radiative transitions in approximately 10^{-8} sec. There is no heating of the

Q-switch despite all the energy that it absorbs, because this energy leaves the Q-switch when the atoms return to the ground state.

This system is arranged so that the laser pulse occurs when the absorption of the Q-switch is on the linear, rising portion of the curve. This allows the output energy to be varied over a ten-to-one range by varying the power to the flash lamp. This type of Q-switch has minimum output pulse jitter because the absorption varies with population inversion, and firing occurs during the fast rising portion of the absorption curve.

OUTPUT POWER AND PULSE CHARACTERISTICS

The ruby laser may be operated in a single-spike or multiple-spike mode with a total energy per shot that can be varied from approximately 0.01 to 0.1 J. The total output (in Joules) may be regulated by a front panel control that sets the charging voltage on the flash-lamp capacitor bank. At a given capacitor bank voltage or pump-power output level, single-spike or multiple-spike laser outputs may be obtained by operating the ruby at appropriate ambient temperatures. At a given power level, a low temperature favors production of multiple-spike output; a high temperature, single-spike operation. If the temperature is excessive, the laser will not fire because the laser energy will not be sufficient to overcome the Q-switch absorption. It is desirable to operate the ruby well above the usual ambient temperatures that may be encountered and at a reasonable power output. Operating conditions of 43.5°C and 3800 V have been found to produce a single-spike output having a peak power of 5 MW and a pulse length of 20 nsec, which is a total energy of 100 mJ. Operating temperature is reached within about 1 min when the ambient temperature is 72°F and the humidity is 50%. Equilibrium at lower temperatures and higher humidities will take longer.

The ruby temperature is monitored by a thermistor bridge that controls a heater to maintain the ruby at the specified temperature above ambient. Thermal equilibrium is maintained by an electric heater and a high-velocity cooling air stream. Although the laser has an automatic system to control the ruby temperature, a mercury thermometer has been supplied to visually monitor the temperature.

The peak pulse-power-reproducibility specification of the laser manufacturer is plus or minus 10%, or less than 0.05 log exposure units. The over-all effect of this change in laser peak power would cause a variation in contrast of 10% in the reconstructed image, because the reconstructed image will have a contrast factor of one-half gamma although the hologram film is processed to a photographic gamma of 2.

The power output of a pulsed laser may be monitored with a commercial instrument, such as the Lear Siegler Model MI-2 Laser Energy Monitor. This instrument measures the total laser energy by using a calibrated photodiode in series with a fixed capacitor and a charging voltage. The photodiode conducts only during the laser output to charge the capacitor. The total capacitor charge (in volts) can be related to the total laser energy output with an accuracy of plus or minus 20%.

The velocity of the particles to be photographed determines the necessary pulse length or exposure time. If we use the criteria that the particle will not move more than one-tenth of its mean diameter during the exposure time, the required pulse length (t) can be computed and plotted as a function of velocity and particle size, as shown in Figure 7. The useful region is that portion under the curve. For faster moving particles, the record on film will have the appearance of a streak. The dimension of the particle perpendicular to the direction of motion can still be obtained, however.

The pulse length can be monitored with a high-frequency oscilloscope that is attached to a laser energy meter or to the simple photodiode pulse monitor shown in Figure 8. Because the laser pulses have extremely short rise times and durations, significant measurement errors will arise as a result of the shunting capacity of the oscilloscope and the limited rise time of the oscilloscope amplifiers. Curves supplied by the manufacturer of the photodiode (Edgerton, Germeshausen and Grier, Inc.) can be used to evaluate graphically the effect of the shunting capacity and limited oscilloscope bandwidth on the laser pulse measurements.

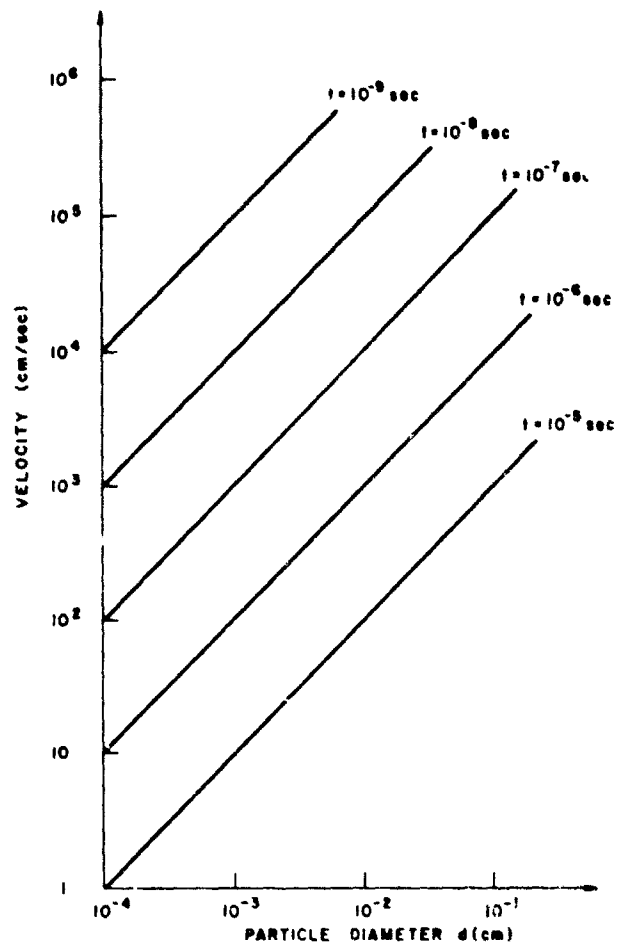

Figure 7. Variation of Allowable Velocity Versus Particle Diameter

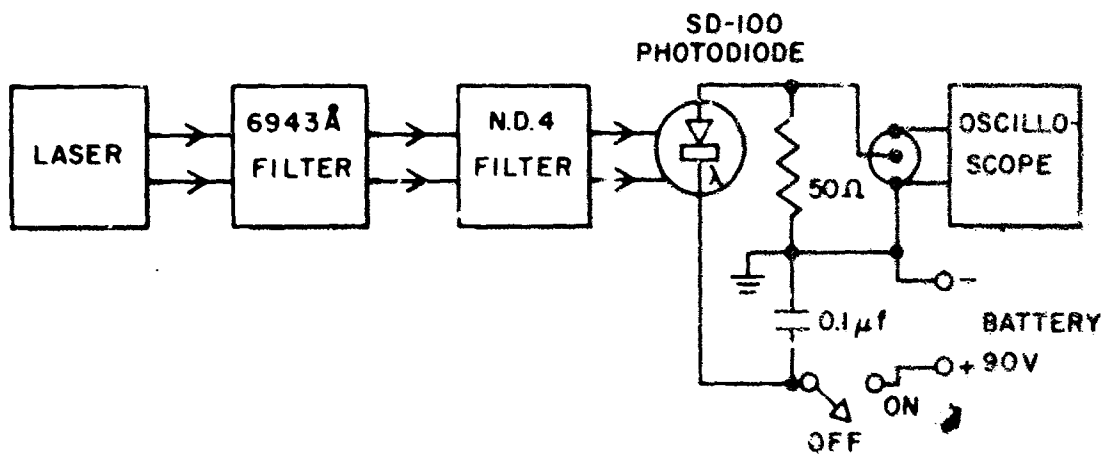

Figure 8. Pulse Length Monitor

INSPECTION AND ALIGNMENT

CAUTION: The laser power source contains a high-voltage power supply and storage capacitor bank that can produce and store lethal electrical potentials. Electrical component failure or line power failure can discharge the storage capacitor bank that will result in unexpected laser light output and cause retinal damage from exposure to high-power laser beams.

The optical components of the laser may be inspected after disconnecting the laser head from all power cables and removing the cover plate. An inspection mirror may be used to check that the sapphire window is clean, that the Q-switch and prism are unpitted, and that both faces of the ruby rod are polished and clear.

Optical alignment of the laser head may be checked externally without disassembly of the laser head by using a small CW laser with an output of about 1 mW and a piece of cardboard (see Figure 9). A test beam that is parallel to the ruby axis will show reflections of the prism and sapphire window imaged back on the test source if the laser is properly aligned. Briefly, the alignment procedure is as follows:

1. To ensure a parallel beam, adjust the test beam so that it enters the center of the sapphire flat when the laser is moved along a flat surface over a distance of 1 ft and 10 ft from the flat.
2. Observe both Brewster faces on the ruby rod to ensure that the test beam is near the center of the rod. (A small piece of paper placed against the ends of the rod will make the position of the test beam easy to see.)
3. Find the reflections of the prism, Q-switch, and sapphire flat that are imaged back toward the test source. (Passing a piece of paper in front of the Q-switch and the prism will identify the images.)
4. Center the reflection from the sapphire flat back upon the alignment or test source by adjusting the 4 Allen head screws

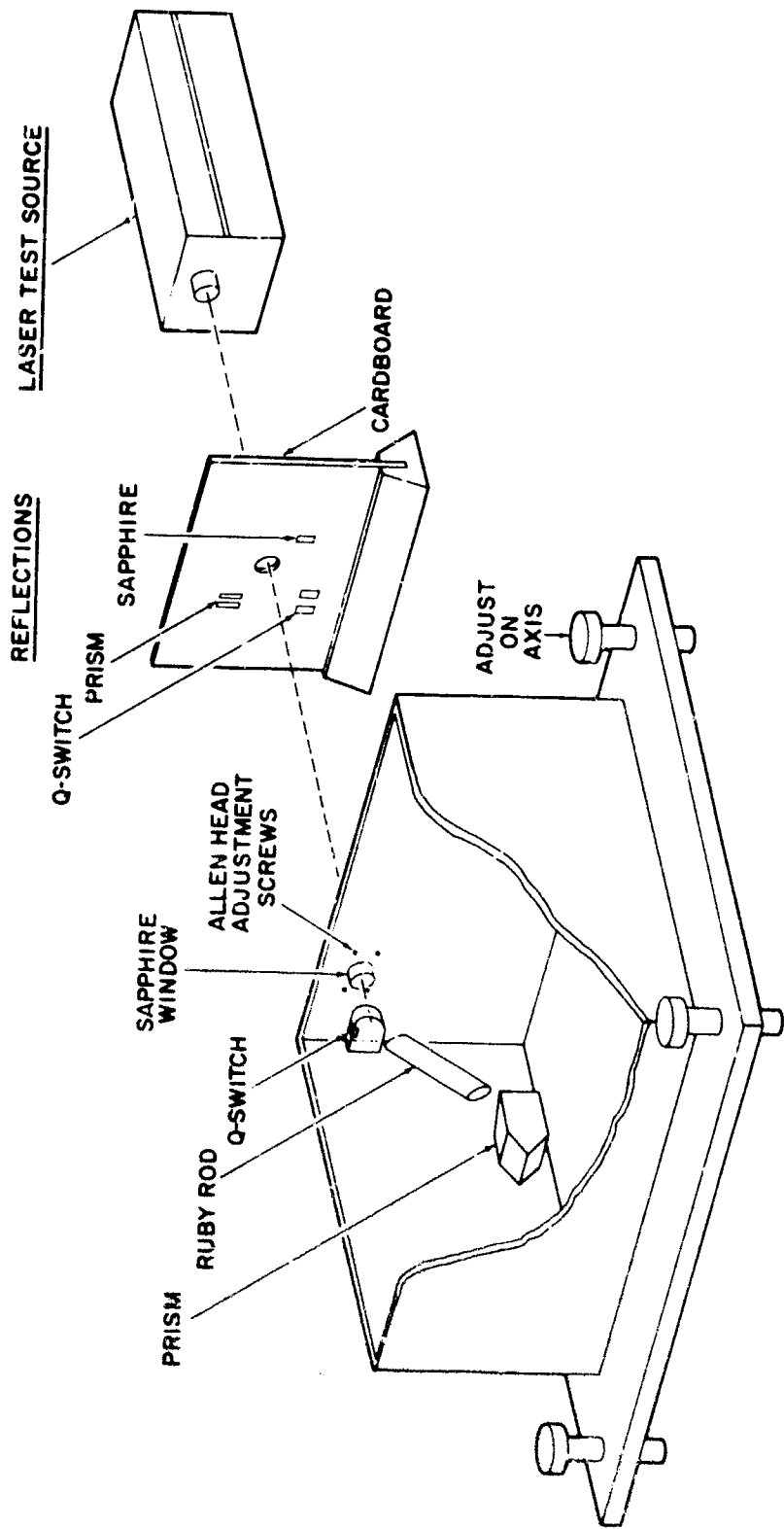

Figure 9. Laser Alignment

around the laser beam output port. (These screws control the pressure of the sapphire flat against an "O" ring.)

5. Center the reflection from the prism back upon the test source.
6. To avoid interfering reflections within the cavity, the reflected image of the Q-switch should be located off-axis; the exact location is unimportant.

LASER BEAM COLLIMATOR AND LASER LIGHT TUBE

At the sapphire resonant reflector, the mode patterns of both ends of the folded resonant laser cavity appear. The function of the laser beam collimator is to take one of these output patterns and produce a uniform intensity beam that is well-collimated and that has a degree of coherence of 0.88 over a coherence interval* of at least 1 cm within the picture volume. The resolution requirement that imposes the specification on spatial coherence is discussed in Chapter 5.

Kilcoyne²⁶ studied the properties of multimoding pulsed ruby lasers by taking high-speed photographs to analyze the mode patterns that are present in a single output beam. He reports a fringe visibility of 0.66 for slits with 1.52-mm spacing. When the ruby was pumped to threshold, the spatial coherence was independent of the spacing between the laser and the slits that were used to measure fringe visibility. When the laser was pumped 7% over threshold, multiple spikes were generated and the fringe visibility measured at a distance of 30 cm from the laser was 0.15. The fringe visibility at 130 cm was 0.45, and the curve rose with increasing distance. It was also found that beam divergence increased for single-spike output, indicating a smaller effective source size than that of the multiple-spike output. From these experimental results, one may conclude that the coherence interval of a carefully aligned ruby laser operating in a single-spike mode is about 1 mm at the output of the laser. If the output beam is enlarged with a ten power telescope, the resulting beam will be well-collimated with a coherence interval of 1 cm, which

*The coherence interval is defined here as the separation of two points for which the degree of coherence is 0.88.

is sufficient for all lens systems supplied with the hologram camera except the 1X magnification system. For the 1X system, additional spatial coherence and beam size are provided by changing the collimator eyepiece to provide a 30X telescopic collimator. Simple non-cemented, plano-convex lenses have been found satisfactory for the collimating telescope. Cemented lenses deteriorate rapidly in high energy laser beams, because the cement absorbs energy and changes the refractive index by destroying the seal between elements of the lens.

The distance from the laser to the picture volume is approximately 12 ft. This long path length will tend to improve the spatial coherence of the beam with the distance traveled in the event that the laser is operated at over-threshold conditions. Of course, over-threshold operation produces multiple spikes that will result in a longer pulse length. If a particle does not move more than one-tenth diameter during the pulse duration, the film will record the required hologram.

The laser light tube is fitted with optical flats on each end to protect it from the blast. The tube is filled with helium and maintained at a positive pressure of approximately 5 psi so that contaminated atmosphere does not enter the light tube. Helium is used in preference to other common laboratory gases, such as nitrogen, because it has a much simpler atomic structure and the light scattering is approximately one-seventh that of air or nitrogen.

Two optical stops are provided between the laser and the collimator. The first stop is approximately 1/4 in. in diameter and is located approximately 2 in. from the laser. This stop masks off very divergent pump light. (The metal surfaces of smaller diameter stops placed at this point were vaporized by the intense beam and, thereby, produced an undesirable source of contamination next to the sapphire laser output reflector.)

A second stop 0.087 in. in diameter is located approximately 12.5 in. from the laser output port. This stop is positioned to select a single output beam and to further block out extraneous pump light. For a well-collimated beam, the output diameter of the beam will be equal to the magnification of the telescope times the 0.087-in. aperture dimension. The output beam at the picture volume will be slightly larger than calculated due to beam divergence.

CHAPTER 4
HOLOGRAM CAMERA APPARATUS AND CONTROL UNIT

GENERAL DESCRIPTION

Figures 10 and 11 are photographs of the camera and its accessories. The assembly details are shown in Figure 12.

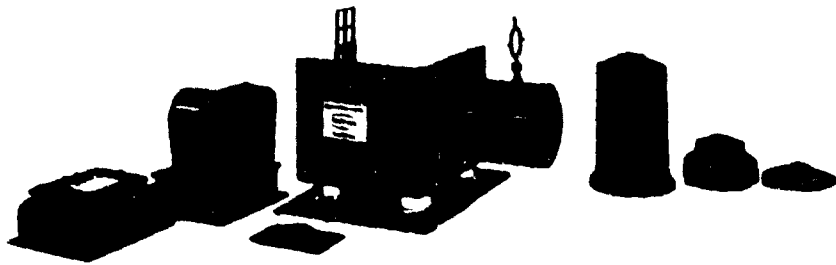

Figure 10. Camera and Accessories

The camera enclosure is fabricated of anodized aluminum that varies from 1/2 to 1 in. in thickness. Side plates are secured by captive screws that may be easily removed without tools. The camera has connections for a 5-psi helium supply to provide positive internal pressure that will prevent leakage of contaminated gases into the camera case.

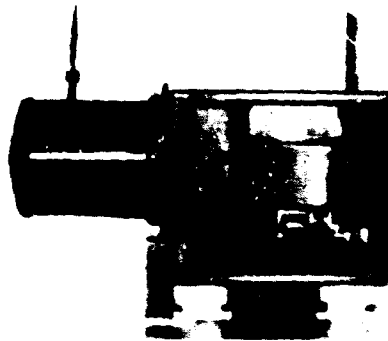

Figure 11. Camera Magazine and Shutter Actuator

LEGEND

- A Assembly of Lens Mounts
 - B Front Plate
 - C Front Inner Plate
 - D Side Plate
 - E Top Plate
 - F Bottom Plate
 - G Back Plate
 - H Front Sight
 - I Rear Sight
 - J Adjustment Device
 - K L.H. Stopper
 - L R.H. Stopper
 - M Assembly of Shutter Mount
 - N Nut for Captive Screw
 - O Assembly of Film Transport Holder
 - P 1/4-20 x 1-1/4 Kourfed Thumb Screw (Fabricated)
 - Q 1788-2 Captive Panel Screw & Bushing - "Cambion"
 - R C-2020-76 Shock Mount - "Barry"
 - S 70 mm Film Magazine
- (The remaining call outs (a to f) indicate the hardware items.)

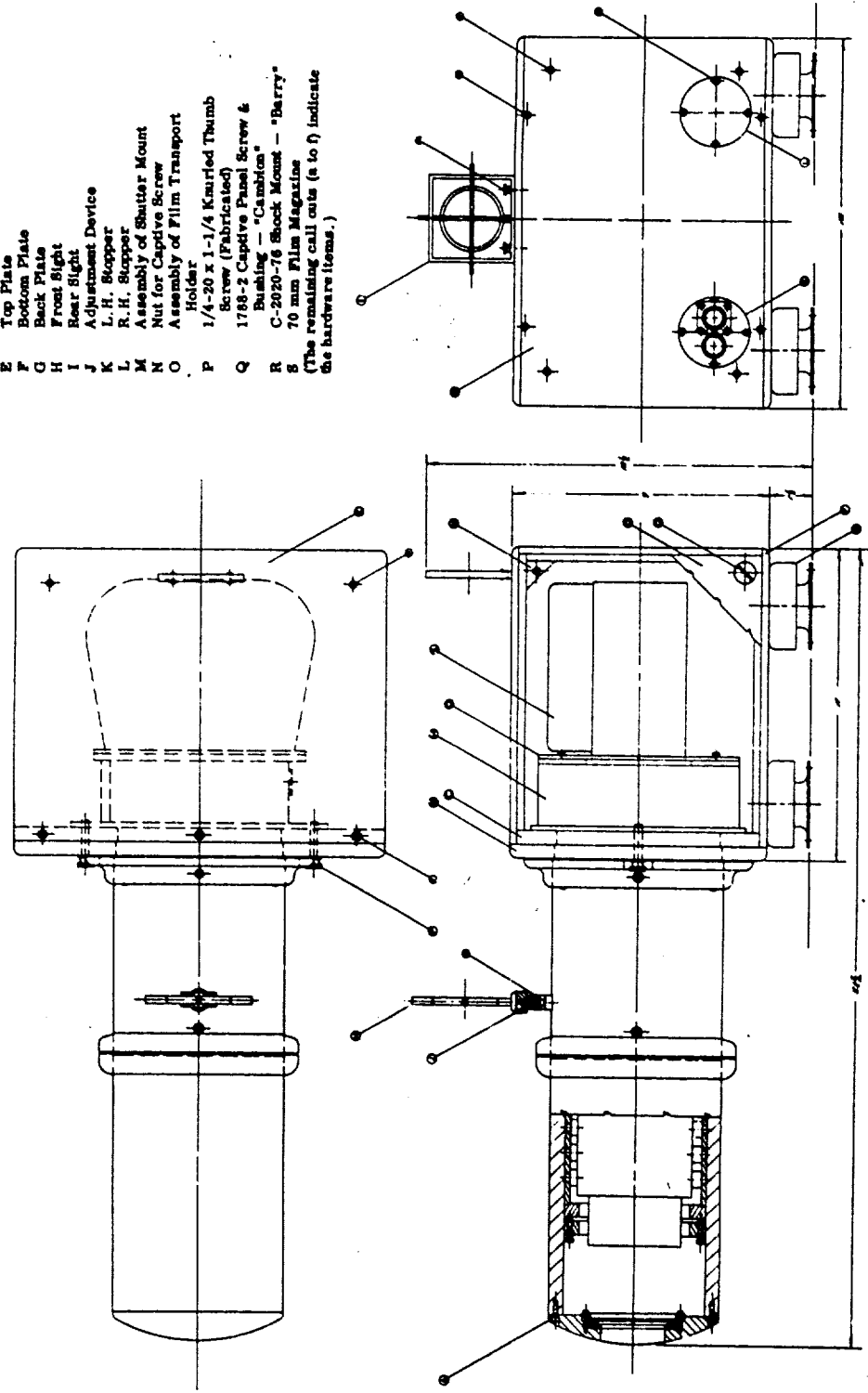

Figure 12. Camera Assembly

Shock-mounted glass optical flats provide external lens protection, and all of the lenses are shockmounted. The lens systems are of modular construction and can be easily interchanged. Two different types of lens systems, telescopic and single lens, are provided. The telescopic lenses are F 1.8 systems. They use a single objective lens, and a choice of four different eyepiece lenses, to give magnifications of 1X, 3X, 10X, and 16X. The objective lenses are coated for single wavelength operation at 6943 \AA to reduce reflections that are encountered when recording holograms close to the lens.

Single lens systems with F numbers of 1.6 and 0.95 provide magnifications from 2.9 to 25X. Short, medium, and long lens barrels, the internal surfaces of which are coated with black velvet to reduce spectral reflections, are used. The single lenses are recessed more deeply for additional blast protection.

Table 1 gives the various lens configurations and the minimum particle size range for each lens.

The picture volume starts approximately $1/8$ in. in front of the lens cap. In general, the camera will record holograms from which particle reconstructions can be obtained over a depth of field extending from 1 to 100 far-field distances from the front focal point of the lens used. We define one far-field distance as equal to d^2/λ , where d is the mean diameter of the particle and λ is the wavelength of laser light (6943 \AA). The hologram camera does not require focusing. The information recorded as a part of each hologram includes a focusing term on each pattern so that during the reconstruction, each particle will focus at its proper location in space.

Two film backs are included. There is an electric 70 mm (4.5 x 6-^{Cm} format size) film transport for photographing expanding clouds and aerosol decay studies, and a 4 x 5-in. Graflok back that can be used with a Polaroid adapter for system check-out purposes or with 4 x 5-in. cut film or plate holders. Holograms made with Kodalith glass plates exhibit particularly fine resolution.

A 3-in. diameter Ilex leaf shutter is mounted near the focal plane. It is used to prevent unwanted ambient illumination from fogging the film before or after the aerosol bomb detonation.

TABLE 1
HOLOGRAM CAMERA PERFORMANCE CHARACTERISTICS

Magnification (%)	System	Camera Barrel	Lens System F Number	Particle Size* (μ)	Depth of Field	Distance Lens Cap to Picture Volume (mm)	Recorded Volume on 4 x 5-in. Format			Recorded Volume on 70-mm (4.5 x 6 cm) Format		
							Projected Diameter	Area	Volume	Projected Dimensions	Area	Volume
1	Telescopic	Objective	1.8	85	10 cm	9.27	5.72 cm	25.6 cm ²	256 cm ³	4.5 x 6 cm inscribed in 5.72 cm dia	25.6 cm ²	256 cm ³
3	Telescopic	Objective	1.8	27	10 cm	4.27	2.12 cm	3.54 cm ²	35.4 cm ³	1.5 x 3 cm	4.5 cm ²	45 cm ³
10	Telescopic	Objective	1.8	14	2.5 cm	3.46	6.35 mm	31.63 mm ²	792 mm ³	4.5 x 6 mm	27 mm ²	730 mm ³
16	Telescopic	Objective	1.8	14	2.5 cm	3.46	3.97 mm	12.3 mm ²	307 mm ³	2.81 x 3.75 mm	10.55 mm ²	264 mm ³
5.43	Single	Short	0.95	14	2.5 cm	7.38	1.37 cm	1.48 cm ²	3.89 cm ³	8.28 x 11 mm	91.1 mm ²	2.28 cm ³
2.92	Single	Short	1.6	22	6 cm	21.17	2.55 cm	5.13 cm ²	30.75 cm ³	1.37 x 2.05 cm	2.75 cm ²	16.5 cm ³
12.75	Single	Medium	0.95	6	5 mm	4.43	5.84 mm	26.8 mm ²	134 mm ³	3.53 x 4.7 mm	16.6 mm ²	83.0 mm ³
5.56	Single	Medium	1.6	13	2.5 cm	11.8	1.34 cm	1.41 cm ²	3.53 cm ³	6.07 x 10.8 mm	0.97 cm ²	2.41 cm ³
25.4	Single	Long	0.95	3.5	1.8 mm	4.37	2.93 mm	6.75 mm ²	12.13 mm ³	1.6 x 2.6 mm	4.16 mm ²	7.48 mm ³
12.75	Single	Long	1.6	11	1.7 mm	4.45	5.84 mm	26.8 mm ²	134 mm ³	3.53 x 4.7 mm	16.6 mm ²	28.2 mm ³

* For good edge detail on 80-243

A camera control unit (Figure 13) is provided for remote operation of the shutter and film. The control unit consists of a frame counter, ohmmeter terminals for indication of shutter position, a lamp that indicates film winding or lack of film, and pulse outputs for firing the laser and Rutherford delay generators. A circuit diagram of the camera control system is shown in Figure 14.

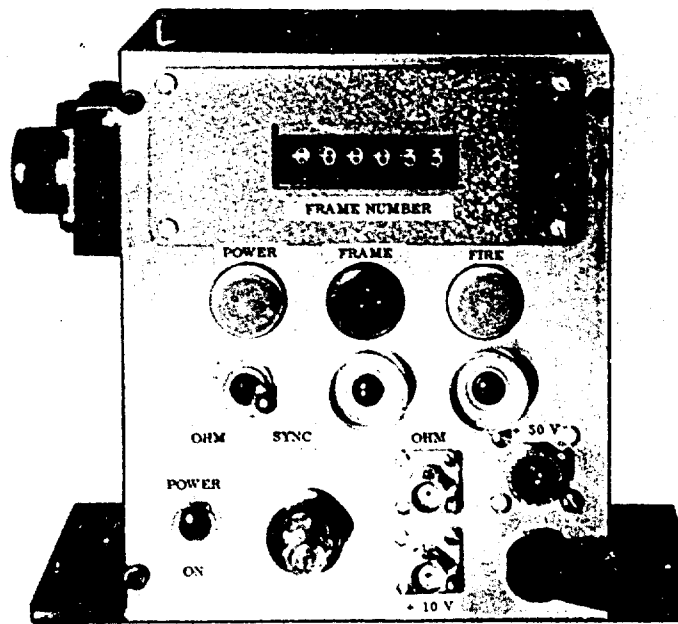

Figure 13. Camera Control Unit

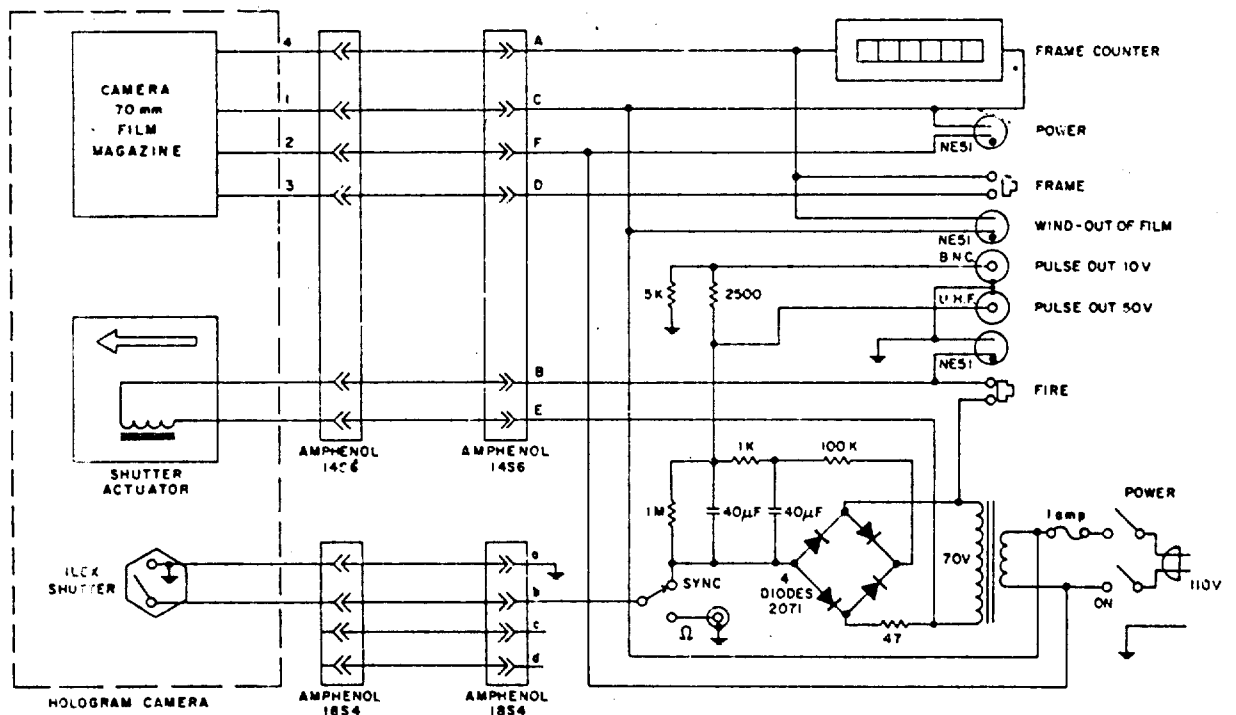

Figure 14. Circuit Diagram: Camera Control Unit

CHAPTER 5

HOLOGRAM CAMERA SYSTEM

RESOLUTION REQUIREMENTS AND SPECIFICATIONS

LENSLESS HOLOGRAM SYSTEM

The resolution requirements of a lensless hologram system can be analyzed by determining the highest spatial frequency in cycles per millimeter that must be stored on the film that records the hologram. The intensity in a hologram of a particle made in collimated light is given by Eq. (1). The second term consists of three multiplicative factors: a constant term, a focusing term, and a Fraunhofer diffraction term. The factor $\frac{k}{\pi z}$ is a constant; $\sin\left(\frac{k\bar{x}^2}{2z}\right)$ may be called the Fresnel lens term, because it provides the focusing action necessary to reconstruct the particle geometries; and the third factor $\tilde{D}\left(\frac{\bar{x}}{\lambda z}\right)$ is an envelope term which is the Fraunhofer, or far-field, diffraction pattern of the particle.

The highest spatial frequency in this pattern that must be recorded in the hologram can be found by differentiating the argument of the Fresnel lens term and expressing the result in terms of particle diameter of the object and the distance at which the hologram is made. By differentiating the Fresnel lens term, we find that the maximum spatial frequency F_1 , as a function of the position vector \bar{x} , is

$$F_1 = \left(\frac{k\bar{x}}{2z}\right) \quad (4)$$

This maximum frequency would require a lens with diameter

$$D = 2\bar{x} = \frac{4z \ell_{\max}}{k} \quad (5)$$

where D is the effective diameter of the lens and ℓ_{\max} is the resolution of the film in lines per millimeter.

Furthermore, the effective F number of such a Fresnel lens is

$$F_{\text{number}} = \frac{f}{D} = \frac{zk}{4z l_{\text{max}}} = \frac{k}{4 l_{\text{max}}} \quad (6)$$

In this example, $f = z$ and $k = (2\pi)/\lambda$. The minimum particle diameter, S_d , that this lens can resolve is

$$S_d = 2 F_{\text{number}} \lambda ;$$

therefore,

$$S_d = \frac{\pi}{l_{\text{max}}} \quad (7)$$

And the resolution of a lensless hologram system is dependent only on the resolution of the film used to make the hologram.

Spatial and Temporal Coherence Effects on Resolution: Determination of Picture Volume

In hologram photography, three parameters of the illumination are significant:

1. The intensity of the illumination (must be sufficient to allow proper film exposure)
2. The spatial coherence as characterized by the coherence interval of the illumination
3. Temporal coherence (spectral purity as characterized by the coherence length of the illumination).

A detailed mathematical analysis of the effect of both spatial and temporal coherence has been carried out by Reynolds.²³ Here we shall attempt to give an intuitive discussion of these effects.

The mathematical derivation of the intensity distribution in a Fraunhofer hologram assumes that the light involved in producing the hologram has nearly perfect

spatial and temporal coherence. In practice, the light is partially coherent, and the contrast of rings in the pattern will be lower than that for the case of perfect coherence. The light should be coherent over the region of the hologram, but a better defined criterion would be desirable. The effect of spatial coherence can be included in the total transfer function of the system. Spatial coherence is characterized in a plane perpendicular to the axis of propagation by the coherence interval.

Consider the case where a hologram is made at many far-field distances from the particle (Figure 15). One then may say that the intensity at any point in the hologram arises from the interference between a diffracted wave coming from the particle and an undisturbed background wave.

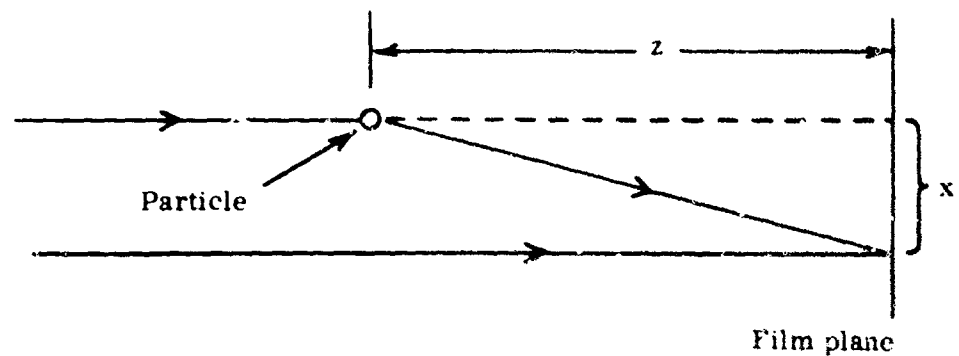

Figure 15. Geometry of Hologram Formation

Assuming that the quasi-monochromatic approximation* is applicable, the contrast of the rings at x will be decreased by a factor, $\gamma_{12}(0)$, where $\gamma_{12}(0)$ is the

* Light that consists of spectral components over a frequency range $\Delta\nu$ which is small compared to the mean frequency $\bar{\nu}$ and for which path differences do not exceed $c/\Delta\nu$ is considered to be quasi-monochromatic. 27

degree of coherence between two points in the object plane separated by a distance x . Therefore, when γ is a function of separation only, we shall use the notation, $\gamma_{12}(0) = \gamma(x)$. The spatial frequency of the rings, L , is given by

$$L = \frac{x}{\lambda z} . \quad (8)$$

Thus, the decrease in contrast can be expressed as a function of the spatial frequency.

In any hologram camera, there will be a maximum depth of field that will determine the limit on frequency response due to spatial coherence. Lack of complete coherence severely limits the resolution of smaller particles that require higher frequency to be recorded. The limiting resolution condition is that for the smallest particle at the largest z distance (this is also the situation when the far-field assumption best applies). Let us, for instance, demand that the degree of coherence between the light which interferes to form a hologram ring be 0.88 or higher:

$$\gamma(x) = 0.88 ,$$

where

$$x = L\lambda z . \quad (9)$$

Then, for a z distance of 1 cm, a coherence interval of 1 mm, and a wavelength of 6943 \AA , a resolution of 143 lines/mm, theoretically, can be obtained. This result still holds if the object volume is magnified. This analysis predicts that spatial frequency response varies inversely as the depth of field, z , and directly as the coherence interval, x .

A light wave exhibits time coherence to the degree that there is a correlation between the amplitude of the wave at a given time and at some later time. A single frequency represents the maximum of time coherence.

In the derivation of the equations that describe the hologram formation, the quasi-monochromatic approximation is used. This assumes that the difference in path length in the picture volume is much less than the reciprocal of the source bandwidth. If one assumes the criterion

$$10 \tau = \frac{1}{\Delta \nu}$$

and

$$\tau = \frac{\delta}{c},$$

then

$\Delta \nu$ = the spectral width of the radiation, where

δ = the path difference between interfering rays, and

c = the velocity of light.

At the n 'th ring, counting from the center of the pattern,

$$\delta = n \lambda ; \text{ and}$$

it can be shown that

$$n = \frac{L^2 \lambda z}{2} . \quad (10)$$

Since $\Delta \nu = (c \Delta \lambda) / \lambda^2$, the condition for the quasi-monochromatic approximation to hold becomes

$$\Delta \lambda < \frac{1}{5 L^2 z} . \quad (11)$$

For the case considered, where $L = 143$ lines/mm and $z = 1$ cm, we must have $\Delta \lambda < 10 \text{ \AA}$.

This condition is well satisfied by the ruby laser, which has a bandwidth of approximately 1 \AA . At a z distance of 10 cm, $\Delta\lambda$ must be less than 1 \AA . This limits recording holograms of particles smaller than 65μ over greater distances.

For the hologram camera system, the collimator is designed to make the coherence interval equal to 1 cm in the picture volume for all lens systems except the 1X magnification system, which has a coherence interval of 3 cm. Under these conditions, the effects of spatial and temporal coherence are comparable.

COMBINING LENS SYSTEMS AND HOLOGRAM SYSTEMS

Although lensless hologram camera systems work very well for recording a limited range of particle sizes, hybrid systems that use lenses and the principles of hologram photography have the combined advantages of both techniques. Lenses in hologram systems can be used for two purposes. The first purpose is to transfer the hologram image to the film plane conveniently, so that shutters and filters may be interposed. In such a transfer lens system, the film is exposed in a clean protected environment, which is of primary importance.

The second reason for using lenses in hologram systems is to magnify or demagnify the sample volume so that the image that is recorded on film matches the resolution capability of the film in lines per millimeter. For example, if the detail in the picture volume contains information that requires 1000 lines/mm to record, and the film used can resolve only 100 lines/mm at a reasonable contrast, a suitable lens system can be used to magnify the picture volume by 10 times so that the detail recorded on the film is only 100 lines/mm. The highest spatial frequency, or conversely, the smallest detail that a lens system can resolve is equal to the product of the F number of the lens and the wavelength of the light that is used (see Eq. (6)). The product $F\lambda$ is the diffraction spot radius of a diffraction-limited optical system. If such a lens is focused on objects that are smaller than the diffraction spot, the lens will pass a filtered image of the object, and the size of this filtered image of the unresolvable object will be equal to the diffraction spot of the lens. As a practical consequence of the extremely high resolution requirements of small particle hologram recording systems, lenses of the lowest obtainable F number are used.

The design of optical systems for hologram recording involves matching the resolution of the film to the frequency response of the lens by selecting the optimum magnification that will record the spatial frequencies that are present in the scene or the object.

Frequency Response for Particle Size Edge Detail

In relating particle size to lens and film requirements that are necessary to reproduce a reconstructed particle with good edge detail, it is instructive to look at the mathematical expression for the diffraction term in the hologram that records the projected area of the particle. This term is from Eq. (1),

$$\tilde{D}\left(\frac{\bar{x}}{\lambda z}\right),$$

where \tilde{D} is the Fourier transform of the original object distribution. When the original object is a particle of circular cross section, the Fourier transform \tilde{D} will be

$$\Lambda_1\left(\frac{\bar{x}}{\lambda z}\right),$$

where

- Λ_1 = Bessel function of the first kind divided by its argument
- \bar{x} = position vector in the recording plane
- z = distance at which the hologram was made
- λ = mean wavelength of radiation.

Figure 16 illustrates the frequency components for edge detail. (a) shows an elemental particle with projected area B_0 ; (b), the transform recorded in the hologram plane; and (c), a two-dimensional graph of the Bessel function plotted on log amplitude versus log frequency coordinates. For practical purposes, it is sufficient that spectra containing an appreciable amount of energy be recorded.

(For further discussion of this subject, see Born and Wolf,²⁵ p. 420 et seq.) Figure 16(c) shows that nearly all of the energy in the Bessel function is contained in the

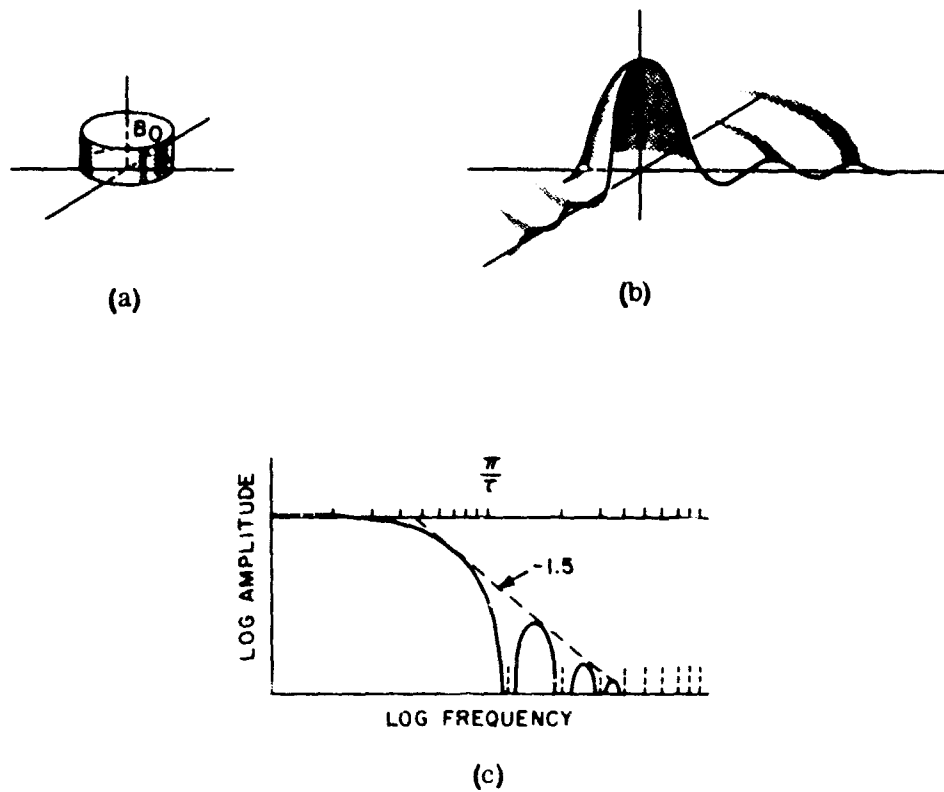

Figure 16. Frequency Components for Edge Detail

spatial frequency band that includes the first 4 harmonics. Moreover, the amplitude of the higher frequency components falls off with a slope of -1.5 . This means that the amplitude as a function of frequency is falling off at the rate of approximately 9 dB per octave. In a single octave, the amplitude of higher frequencies will be down by a factor of 0.126. The amplitude variation of frequency components over a 4 to 1 frequency range is approximately 18 dB.

Gabor³ has shown that a gamma of 2 must be achieved in the hologram development process, because the contrast in the final reconstruction is equal to $1/2$ gamma. Although an amplitude range of 18 dB is present in the hologram image, the gamma of 2 development process makes the recorded hologram have a dynamic amplitude

range of 36 dB. The linear dynamic range that one can obtain with available film at a gamma of 2 is about 2 density units which are sufficient to store a 40 dB amplitude variation. Therefore, the exposure requirements deserve careful attention in order to achieve best results. The lenses and film in the hologram recording and reconstruction system must be able to pass the first 4 harmonics of the particle diameter (or of its projected area). For computation of the smallest particle that can be resolved by a given lens and film combination, experience has shown that systems must be designed to include resolution of the first 7 harmonics. These criteria are used in Table 1 to specify the smallest particle that a given lens and film combination will resolve with good edge detail. These resolution criteria have been developed for small particles; of course, any larger particles will also be satisfactorily resolved.

SYSTEM DESIGN: SELECTION OF OPTIMUM CHARACTERISTICS

In the preceding sections, the characteristics of the illumination in the picture volume have been discussed in detail. Specifically, the spatial coherence, the temporal coherence, and intensity of the light are of primary importance. The limitations imposed by the resolution capability of the film and by diffraction-limited lens systems have been considered as a function of the frequency detail in the particle.

For the particle size range from 3 to 30 μ , magnification is required in the camera system. Telescopic systems recreate the picture volume with the background illumination perfectly collimated and parallel to the optical axis. Theoretically, if the telescopic system is perfectly corrected, the aberrations will be only those present in the basic process that forms the hologram. For this reason, four telescopic lens systems have been provided. The aberrations of a hologram recording system have been discussed by Armstrong²⁸ and Meier.²⁹

Single lens systems have many advantages. Long focal length lenses can be used at high magnification without requiring, expensive, large diameter objective lenses. The long focal length of single lenses allows the lens to be deeply recessed, so that particles and debris from the bomb will not impinge on the protective lens flat.

Details of the full lens complement are given in Table 1. The minimum theoretical particle size for good edge detail and the depth of field of the sample volume are given for each of the ten lens systems that have been supplied.

CHAPTER 6

FILMS FOR HOLOGRAM PHOTOGRAPHY

Special films have not been made for hologram photography, and none of the commercially available films has ideal characteristics.

A visual examination of reconstructions of sample particles of known size is probably the best method of evaluating the over-all reconstruction properties of a film. Many defects can render a film unsuitable for hologram photography. Some films exhibit clumping tendencies and have large grains that can be seen under the microscope. Many films have an objectionable relief image that is caused by the swelling of the gelatine emulsion during processing; this variation in film thickness causes phase distortion in the hologram image. It is important to bear in mind that the hologram reconstruction requires both phase and amplitude information to be faithfully recorded.

Most films include special purpose layers that are objectionable, because they affect the phase characteristics of the film. Some of these coatings are applied to the back of the base layer to equalize expansion characteristics (anti-curl), to prevent reflections from the back of the film (anti-halation), and to prevent the build up of static charges on the film (anti-static). Some of these layers can contain air bubbles or inclusions with a mean diameter of approximately 10μ . Such inclusions can cause intolerable noise in hologram systems.

The general requirements of film, as an element of a coherent optical system, have been discussed by Leith.³⁰

The first requirement is high resolution capability; this requirement stems from the use of the film to store the focusing information for the reconstruction as well as the object detail, as discussed in Chapter 5. The film used for hologram photography also requires sensitivity at a single frequency in the spectrum, at 6943 \AA for systems that use the ruby laser for illumination. Most panchromatic films have a very low response at this frequency. Infrared films have good response at 6943 \AA , but they have sensitivity in the infrared; hence, a filter is necessary to block off radiation at longer wavelengths. The fastest suitable film is the Kodak High Definition Aerial Film, Type SO-243, which has a resolution capability

of 110 lines/mm at 50% contrast and extended red sensitivity with a peak in the response at approximately 6900 \AA . The high speed of this film makes it suitable for use with additional collimator magnification to provide a larger picture volume and lower signal-to-noise ratio.

The highest resolution recording media that we have encountered in our research is Kodalith Panchromatic glass plate. It has the disadvantages that it is nearly 12 times slower than the best film and it must be used in a single exposure glass plate holder that allows one picture per test explosion.

Gabor³ has shown mathematically that processing a hologram film to a gamma of 2 will restore the original contrast of the object, and he has also shown that, if the object has high contrast and is processed to a gamma higher than 2, spurious resolution will add extraneous detail to the picture.

For diffraction patterns of very low intensity, however, one can improve the contrast by developing a film such as Kodalith plate to a gamma of 8, but this procedure has the disadvantage of making the exposure extremely critical. For an exposure change of only 0.1 density units, the hologram background level would change by 0.8 density units. Processing to a high gamma does not improve the signal-to-noise ratio and is recommended only when there are objects of very low contrast that cannot otherwise be distinguished.

The H and D curve (density versus log exposure) provides information of great importance concerning the processing of the film and the correct exposure. Provided that the film is carefully processed according to the specifications in Table 2, the slope of the H and D curve will be 2; this slope is called the gamma or contrast factor of the film. The linear dynamic range of the film can be determined from inspection of the H and D curve, and the best background density for a hologram will be located at the center of this dynamic range.

Table 2 presents information concerning the use of four films for hologram recording. The films were evaluated by making static photographs over a wide range of exposures of small particles in laser light, and reconstructing all the photographs to determine contrast and edge sharpness. Developing formulas and processing times were selected to give a gamma of 2. The best background density

TABLE 2
FILM CHARACTERISTICS AND PROCESSING DATA

Film	Relative Speed at 6943 Å	Percent Contrast 50 ℓ /mm 100 ℓ /mm 200 ℓ /mm	Developer and Time for Gamma of 2 at 68°F†	Best Background Density	Linear Dynamic Range	Remarks
Kodolith Pan Plate	1	75 [‡] 55* 40	D-76 1.1 3 min	1.0	1.5	High Reconstruction Contrast and Edge Sharpness
Kodak High Definition Aerial Film, Type SO-243, Triacetate Base	12	68 48 32	D-19 3 min	1.2	1.2	Good Reconstruction Contrast and High Edge Sharpness
Kodak Panatomic X Aerial Film, Type 4400, Estar Thin Base (2.5 mil)	45	55 30 15	D-76 12 min	1	1.2	Good Contrast, Fair Edge Sharpness, Low Noise in Image
Kodak Panatomic X Sheet Film	1	45 20 8	D-19 10 min or D-8 3 min	1.8	1.5	Low Contrast, Low Resolution, and Low Noise

* Estimated.

† Development times shown are for agitation during 5 sec out of every 30 sec.

was found to be located at the center of the straightline portion of the H and D curve. The modulation transfer function characteristics, which indicate the number of lines per millimeter that can be recorded at a given contrast, were obtained from the manufacturer where available, or estimated when not available.

As the market for hologram recording film increases, a special film will probably be made with extremely high resolution, single frequency response, flat surfaces with good optical homogeneity, and high speed. There is a requirement for a film that will have a linear dynamic range of 2 or more when developed to a gamma of 2. The performance of hologram systems will show a marked improvement when films especially designed for hologram recording are available.

CHAPTER 7

FLASH FILTER

The flash filter prevents film exposure due to the flash of the explosion, laser pump light, and the long duration Argon flash system that is used for auxiliary equipment illumination.

Tests to determine the relative intensity of the flash were made with the optical axis of the camera located at a distance of 2 ft from the center of the bombs. The camera shutter remained open for the duration of these tests and High Definition Aerial Film, SO-243, was used in the camera to record the flash intensity.

Film exposed to the flash from a 25-g explosive showed negligible exposure. The 100-g explosive caused background density of 0.8. The combination of the 100-g explosive and a 120-g Argon flash lamp produced a background density of 1.84.

Narrow-band interference type filters were found to be unsatisfactory for this application, because their multiple-layer construction caused many unwanted interference fringes. A Kodak No. 70 Wratten filter was satisfactory. This filter is a high band-pass filter with a sharp low-wavelength cutoff of 6250 \AA . The SO-243 film has a sharp cutoff at approximately 7150 \AA , and the resultant combination of the film and the Wratten filter produces a band-pass filter centered at approximately 6800 \AA with a pass bandwidth of approximately 600 \AA .

The Wratten filter is located inside the camera box. No detectable exposure of SO-243 film has been recorded when the camera has been operated with shutter open under the ambient conditions of explosive charges up to 100 g and Argon flash-lamp charges up to 120 g.

CHAPTER 8

RECONSTRUCTION SYSTEM

GENERAL DESCRIPTION

During the reconstruction process, a three-dimensional model of the microcosm of the aerosol cloud is produced. Any particle in the picture volume can be brought into focus and examined at will. The reconstructed volume has a scale that is related to the picture volume through the lateral and longitudinal magnification of the optical system utilized in the laser camera. If the lateral magnification in the camera in X and Y directions is designated by M , the longitudinal magnification in the reconstructed volume is equal to M^2 . This relationship holds for all magnification systems and can be derived by using the principles of geometrical optics (Ref. 25, p. 152). The components of a reconstruction system are a light beam with good spatial and temporal coherence, a mechanical stage to allow precision location of the hologram, and a plane for viewing or recording the in-focus objects (see Figure 17).

The hologram contains the superimposed far-field Fourier transforms and the quadratic phase factors that determine the image detail and the wave divergence required to properly focus each individual particle. For convenience, the reconstruction recording plane is fixed in this system, and the hologram is moved to bring all the planes within the picture volume sequentially into focus on the reconstruction plane.

The image on the viewing plane can be visually observed on a ground glass, or it may be observed with a closed circuit television camera and monitor. The advantages of the television camera system are that the contrast of the object may be electrically adjusted to produce sharp images of low contrast objects, and small details in the reconstructed image may be viewed on the large television screen without eyestrain.

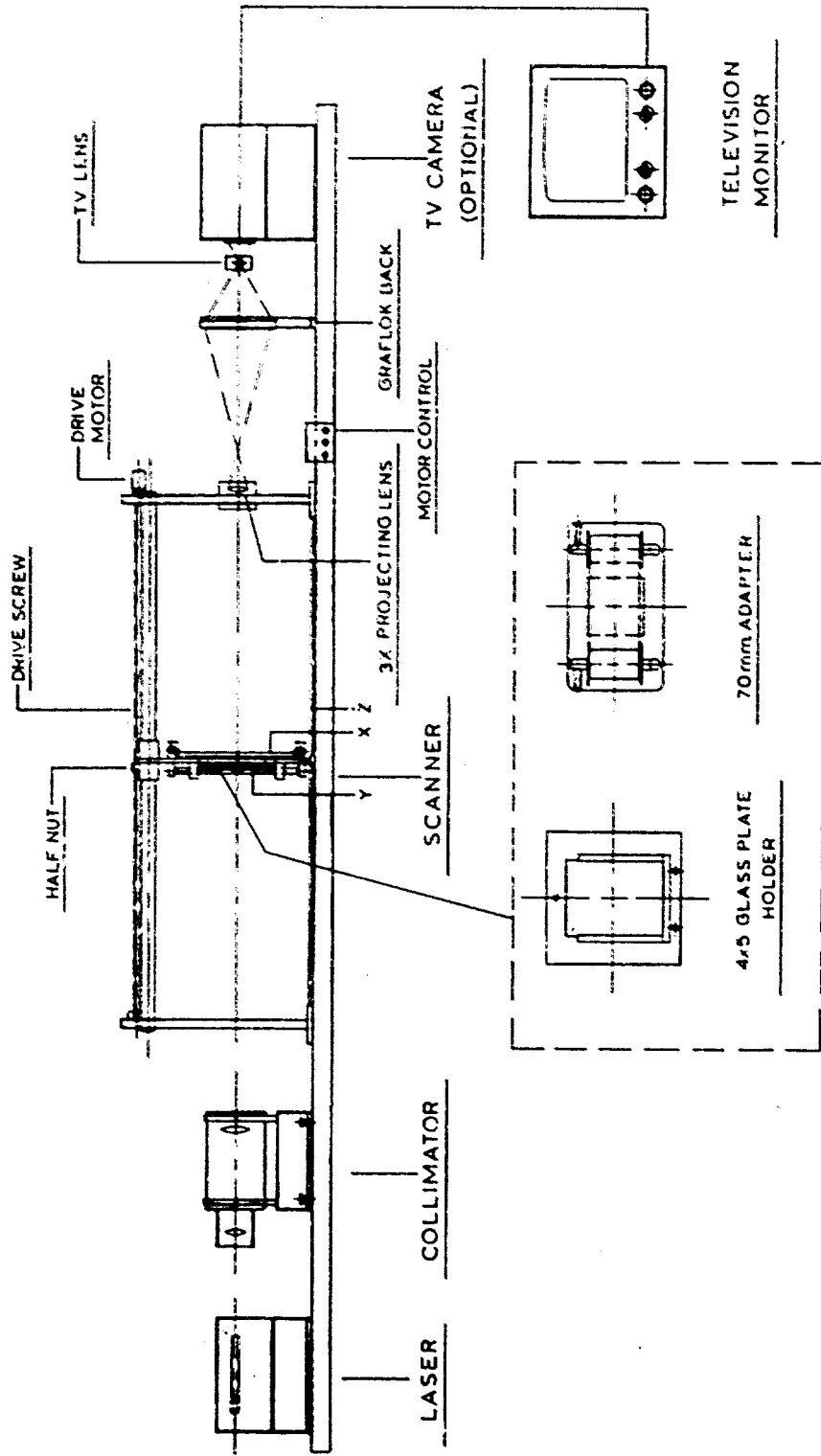

Figure 17. Hologram Reconstruction System

COMPONENTS

RECONSTRUCTION SOURCE

A helium-neon gas laser, Spectra Physics model 130, provides a coherent beam with a diameter of 1.6 mm at 6328 \AA . The magnification in a plane wave reconstruction system is independent of the frequency of light that is used. The power of this laser, when operated in the single phase mode, is 0.3 mW, minimum. The laser has only two controls: a power switch and a power output level control. In a perfectly clean environment, the laser will operate over long periods of time without adjustment. Even in normal laboratory environments, however, contaminants can collect on the mirror surfaces and will lower the output intensity or even cause oscillations to cease. The mirrors can be quickly cleaned to restore power output according to a procedure outlined in the laser instruction book.

COLLIMATOR

A 30 power telescope is used to produce an enlarged and collimated laser beam with a diameter of 2 in. Approximately 2 square inches of the hologram may be photographed in the recording plane at a moderate magnification (3X) so that details in the hologram can be faithfully reproduced on Polaroid or Panatomic-X film. The collimator alignment should be adjusted with thumb screws, so that the beam is precisely on the optical axis, and images on the scanner plate will remain in the same relative position as the hologram is moved through the complete scanning distance.

MECHANICAL SCANNER

The scanning stage is capable of looking at any point on a 4 x 5-in. film over a longitudinal distance of 125 cm. A 4 x 5-in. glass plate holder or a 70-mm roll film adapter can be mounted on the scanner stage. Motion along the X and Y axes can be controlled by means of position knobs connected by a rack and pinion drive to the film stage. Friction brakes are provided to lock the X and Y motion at a specific point. Longitudinal axis motion (Z axis motion) can be obtained with a reversible 94 rpm motor that drives a lead screw having a pitch of 13 threads per inch. A half-nut engages the stage for mechanical drive. For manual movement, the half-nut may be disengaged.

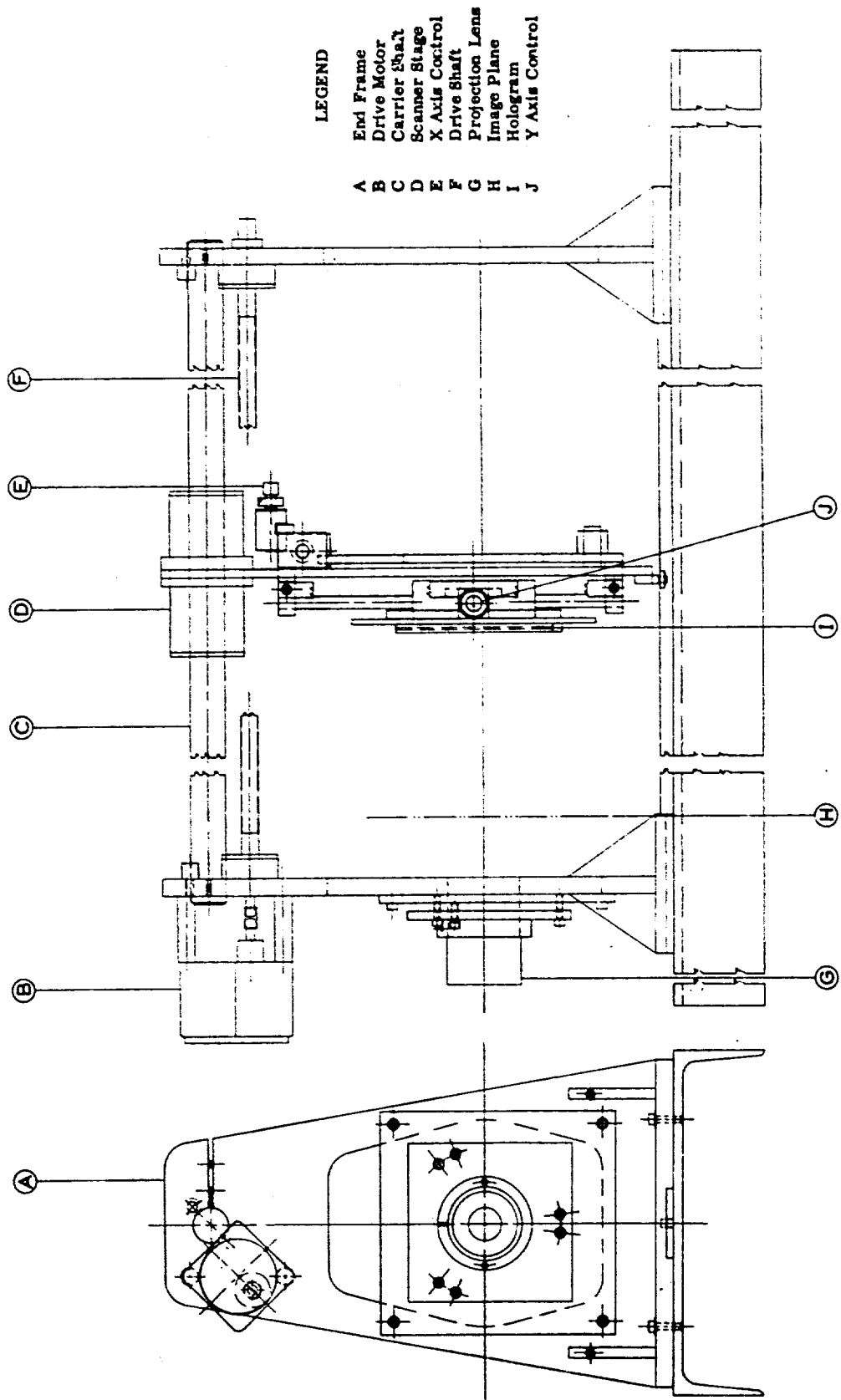

Figure 18(a). Scanner Assembly

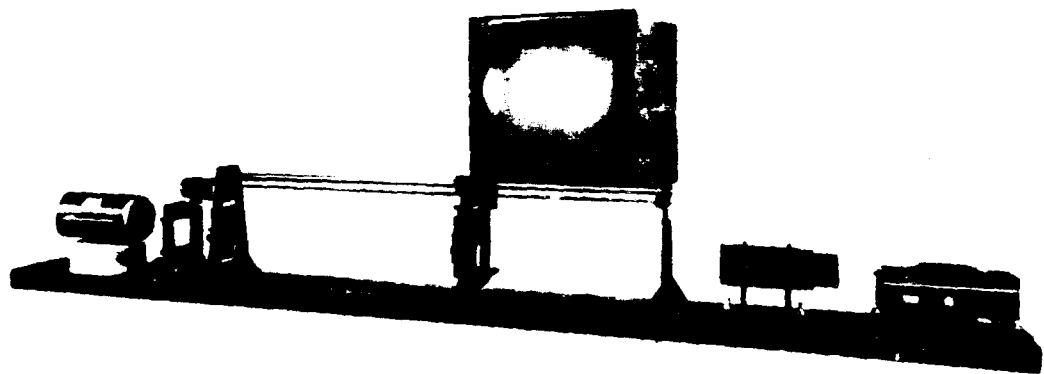

Figure 18(b). Reconstruction Scanner with Television Readout

Scales are located on the X, Y, and Z stages for locating the position of images within the scanning volume with an accuracy of 1 mm. The operator can record the frame number and the X, Y, and Z coordinates of reconstructed detail of particular interest.

All mechanical stages are mounted on three-point mechanical supports, with ball bearings on all friction surfaces. Cylindrical bearings are mounted over case-hardened shafts for supporting the weight of the X, Y, and Z stages. An assembly diagram is shown in Figure 18(a). Figure 18(b) is a photograph showing the reconstruction scanner with television readout.

CHAPTER 9

FIELD INSTALLATION

Installation of the camera and laser light source is shown in Figure 19. The camera is supported inside the test chamber on a rugged framework of 2-3/4-in. diameter steel pipe that is fastened together with U bolts and locked into place between floor and ceiling with six 12-ft steel jacks. The camera may be moved on its supporting platform over a distance of approximately 2 ft to allow lens barrels of different lengths to be fitted.

The entire framework that supports the camera and light tube within the chamber may be installed with only a wrench, screwdriver, and level.

The camera and light tube are purged with helium gas to maintain a positive pressure gradient that will prevent entry of smoke from the explosion.

Blast protection for the laser entrance port is provided by two glass flats that are installed at each end of the light tube and a 1/2-in. aluminum plate and rubber clamp that seals the port on the inside of the test chamber.

The following installation and alignment procedures are suggested for field installation:

1. Install all floor jacks and check for vertical alignment with a level.
2. Install the laser light tube in the chamber port and make sure that it is absolutely level.
3. Observe the position of the collimator objective lens by looking down the light pipe from inside the chamber. Center the objective lens by adjusting screws that support the collimator bed.
4. Illuminate a piece of paper at the entrance aperture of the collimator with a flashlight. Observe that this illuminated pupil is centered when observed from the end of the light pipe inside the chamber.
5. Shine a flashlight through the light tube and the collimator from the picture volume. A demagnified beam will emerge from the collimator eyepiece lens.

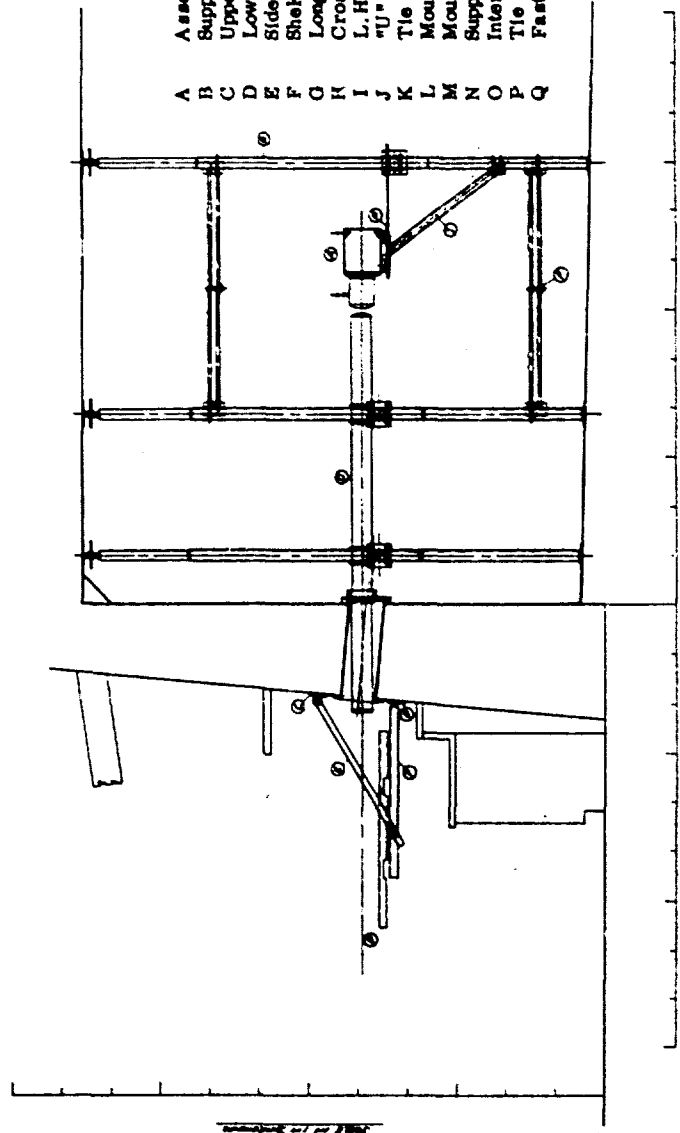
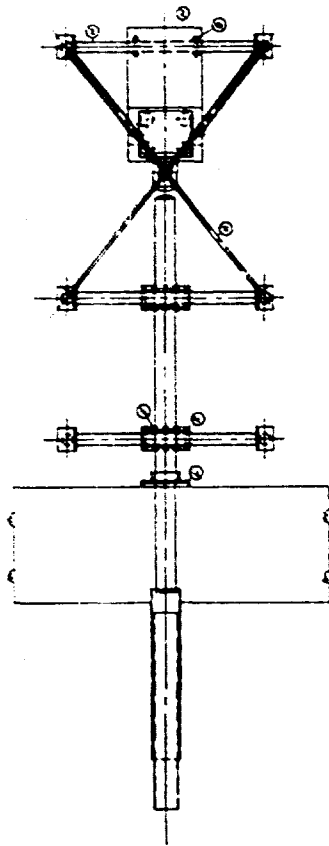

LEGEND

- A Assembly of Laser Camera
- B Support Base for Collimating System
- C Upper Shelf Mounting Bracket
- D Lower Shelf Mounting Bracket
- E Side Supports
- F Shelf Mount
- G Long Post Supports
- H Cross Braces & Supporting Braces
- I L. H. & R. H. Supporting Legs
- J "U" Bolt
- K Tie Plate
- L Mount for 5" Tube
- M Mounting Plate for Camera
- N Support Plate for Camera
- O Intermediate Tube
- P Tie Plate for Cross Braces
- Q Fastening PC for Support Plate

Figure 19. Edgewood: Laser Camera Installation

6. Center the pencil of light on the sapphire flat by moving the laser mounting ring in the X and Y directions.

7. Adjust the Z axis laser mounting ring screw adjustments and watch the sapphire flats from a point near the collimator eyepiece aperture stop. When the correct Z axis adjustment is obtained, the sapphire flats will be transparent and the yellow-green Q-switch will be seen.

8. Place a dark piece of matte paper over the entrance flat of the laser light tube. A mark indicating the center of the flat should be made on the paper. All reflecting surfaces should be suitably masked off. The collimated laser beam should be centered on the matte paper.

9. Transfer the center line of the laser light tube exit flat to a piece of matte paper on the front of the camera. All reflecting surfaces should be masked off. The laser beam should be centered on the matte paper by adjustment of the Z axis screws in the laser head mounting ring.

10. Adjust the 0.087-in. stop that determines eyepiece pupil with its X and Y screws to include only the portion of the beam directly on axis.

11. At this point, test pictures should show a uniformly illuminated field with the 3X lens.

CHAPTER 10

STANDARDIZATION PROCEDURE

Standardization of the camera and reconstruction system can be obtained by locating samples of particles having known size distributions at various Z distances within the picture volume. A wide range of closely sized particles for standardization purposes may be obtained from a particle bank or commercial particle service.

Sample particle distributions are prepared on glass cover slides. Dilute hydro-sols may be evaporated to leave a residue of standard particles. Solid particulate matter can be dusted on the cover glass. An excellent three-dimensional standardization target can be made by using two cover glass slides that have suitable particle distributions and by spacing the slides accurately by a known distance, such as 1 cm. The composite standardization target should be placed in the picture volume and photographed. The standardization hologram that is produced has the following uses:

1. The magnification of the camera can be accurately checked against the known sizes of the standard particles by measuring particle diameters in the reconstructed volume.
2. The distances between the planes where these particles reconstruct is equal to $M^2 \Delta z$, where M is the camera magnification and Δz is the distance between the planes in the three-dimensional standardization target. This gives an accurate check on the camera magnification and an absolute spatial location of the reference planes in the target.
3. This standardization hologram can be used as a particle size calibration picture for records that are taken with the same lens combination regardless of the magnification that may be added during the reconstruction process. The operator can vary the magnification, following the reconstruction scanner stage, as desired.

* A wide range of closely sized particles is obtainable from Particle Information Service, 600 South Springer Road, Los Altos, California.

to bring out any features of the aerosol cloud, and can proceed to record the data on photographic film. If an accurate calibration with particles of a known size is wanted, the operator can take a second picture to obtain an accurate scale by using the standard hologram.

Standard particles of microthene and lycopodium (in two planes located 1.135 cm apart) are shown in Figure 20. Loss of the low energy, high frequency edge detail (Figure 20(c)) is caused by the underexposed hologram which had a background density of 0.5. Standard particles properly exposed with a background density of 1.0 are shown in Figure 21.

(a) Hologram Plane

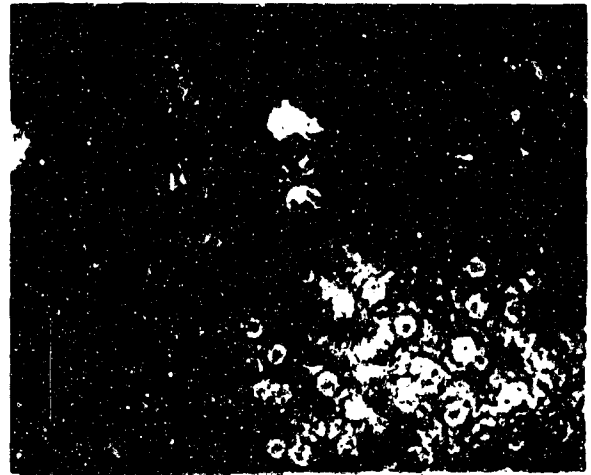

(b) Reconstruction of
Microthene Particles

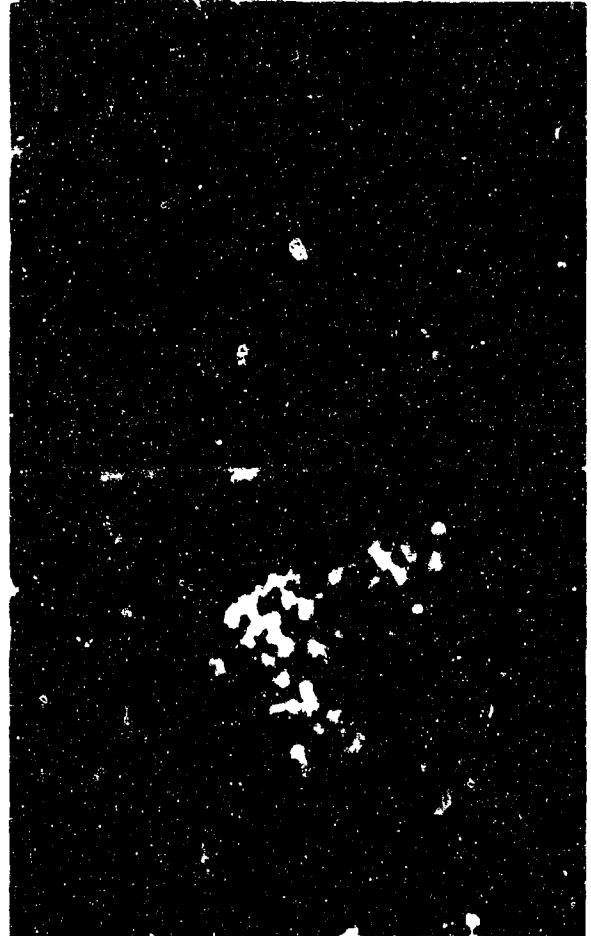

(c) Reconstruction of
Lycopodium Particles

Figure 20. Hologram Reconstruction of Standard Particles
(Exposure background density 0.5)

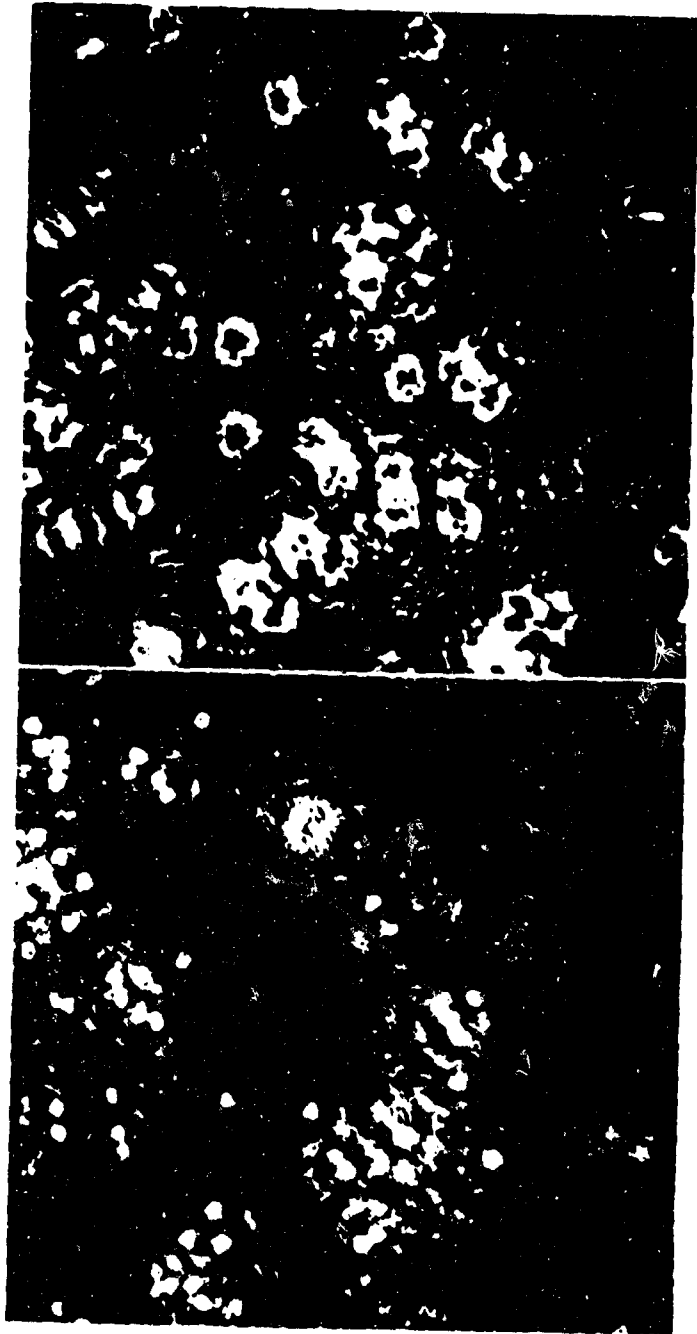

(a) Hologram Plane

(b) Reconstruction of
Lycopodium Particles

Figure 21. Hologram Reconstruction of Standard Particles
(Exposure background density 1.0).

CHAPTER 11

DYNAMIC TEST RESULTS

The hologram camera system has photographed over 25 bombs under a wide variety of conditions. These dynamic tests were designed to evaluate the performance of the camera while photographing high-velocity particles under conditions of shock, high ambient light, and high pressure.

Variation of the spacing between the test bomb and the optical axis of the camera from 12 in. to several feet produced different shock and flash conditions for evaluating the durability and performance of the system. Bare explosive charges were used to produce maximum shock and light. Type number 31 plastic spheres were filled with a variety of solids and liquids to simulate various dispersion conditions. Four aluminum disc dispersion "cannons" were designed and installed to enable standard sized particles to be injected into the picture volume for testing purposes.

The effects of the physical force of the explosions on the camera support frame and floor jacks were unexpected. It was found that the vibrations caused large bolts and even the floor jacks to loosen; this has been remedied by using additional locking devices and periodically checking the tightness of the jacks.

The effects of the 120-g Argon flash lamp are impressive. This lamp produces a focused light (through a 6-in. diameter steel pipe) that is capable of burning up an aerosol. On one occasion, a Type UHF connector block was forced inside the camera; a glass film plate was broken due to the sudden increase in pressure inside the camera. A cover cap has been installed to protect this connector. With this exception, no other glass or camera parts were damaged during the test sequence.

Figures 22 through 27 illustrate the performance of the camera in recording expanding aerosol clouds. Figure 22 shows the hologram plane and three reconstructions of the cloud. Figure 23 is a static shot, but it recorded many particles in the chamber atmosphere. Figure 24 shows a large piece of debris in the expanding cloud. Figure 25 shows a water plume from a liquid dispersion test. Figure 26 shows the hologram of an optical discontinuity; reconstructions are not included because the original negative is overexposed, but the traces visible in this hologram clearly reconstruct in planes in the picture volume that are separated by 25 cm. It seems possible that this hologram may be two shock waves. Figure 27 contains a hologram and two reconstructions.

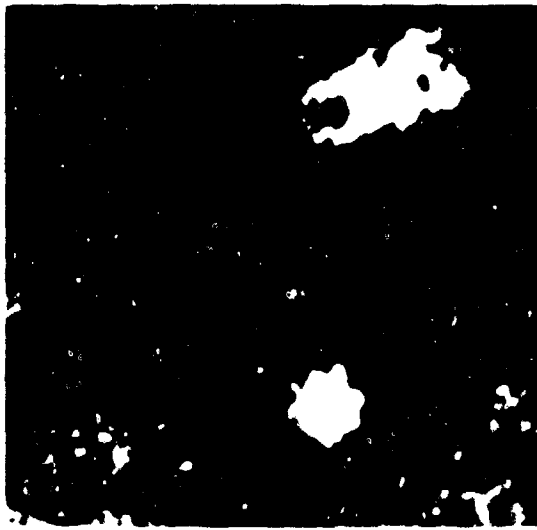

(a) Hologram Plane

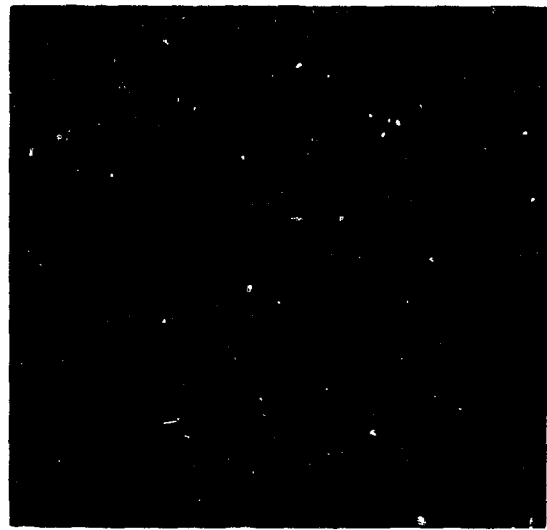

(b) Reconstruction

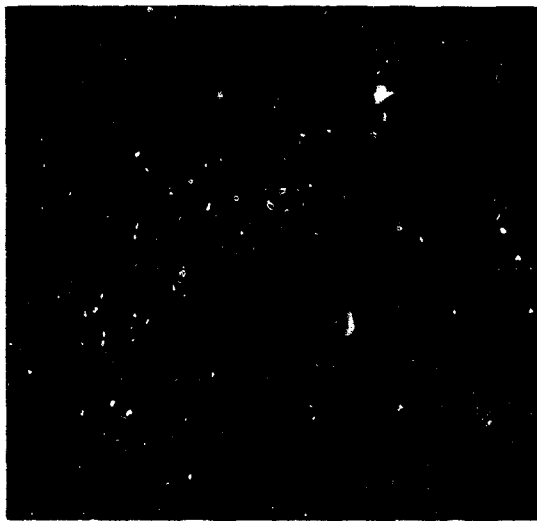

(c) Reconstruction



(d) Reconstruction

Figure 22 Dynamic Hologram Reconstruction

(a) Hologram Plane

(b) Reconstruction

(c) Reconstruction

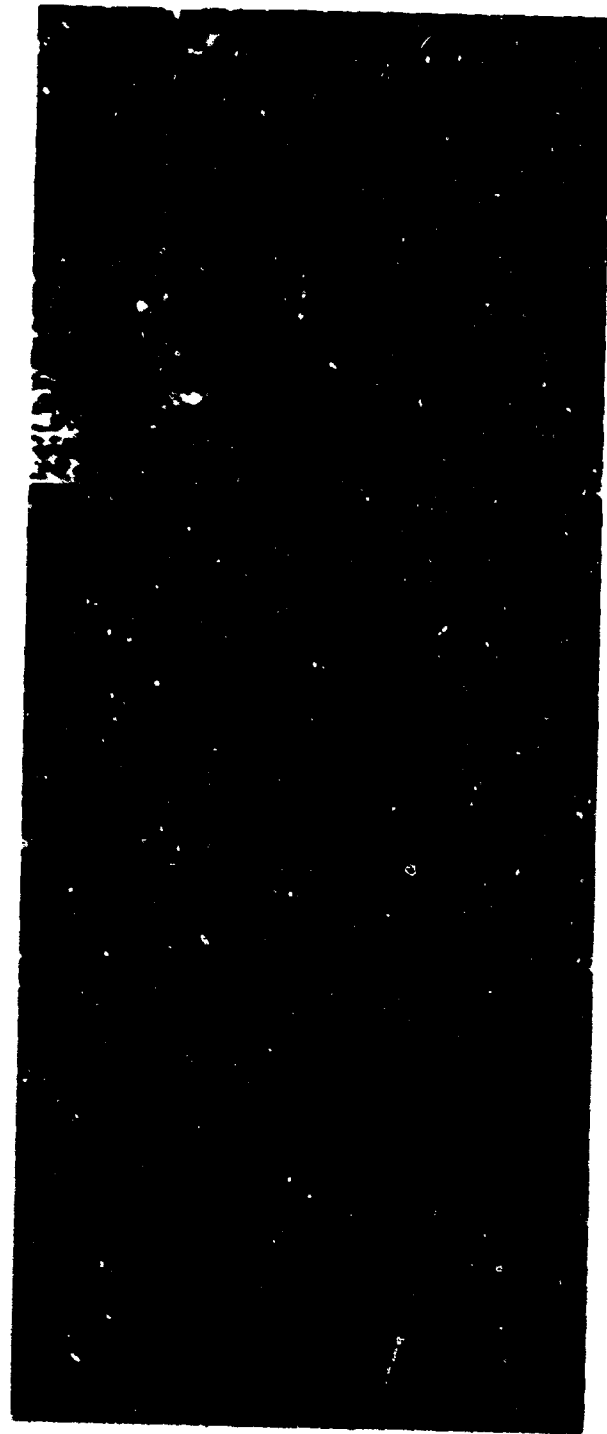

Figure 23. Static Hologram Reconstruction

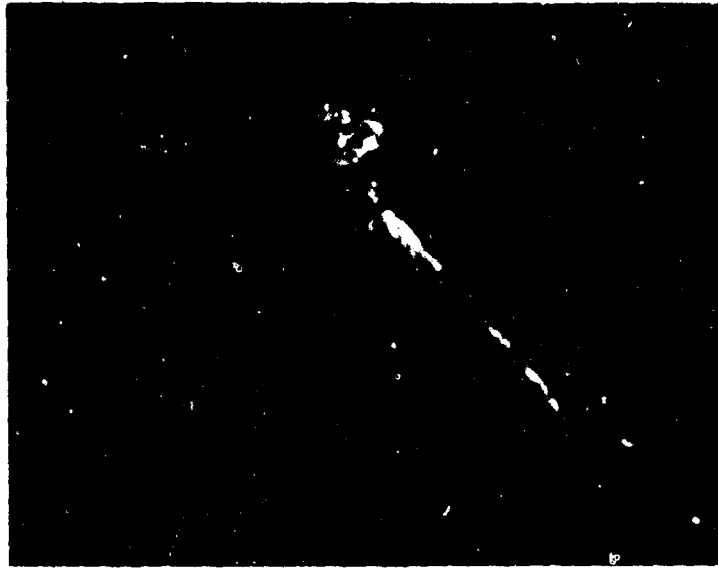

Figure 24. Reconstruction: Debris in Expanding Cloud

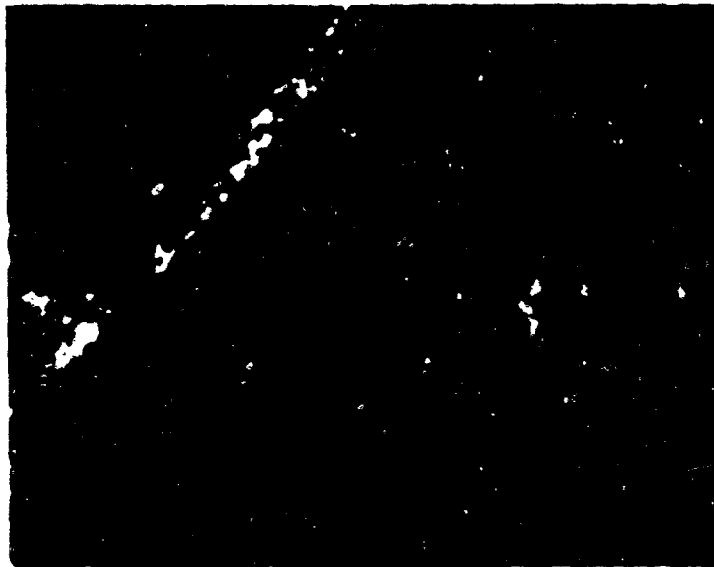

Figure 25. Reconstruction: Water Plume in Liquid Dispersion Test

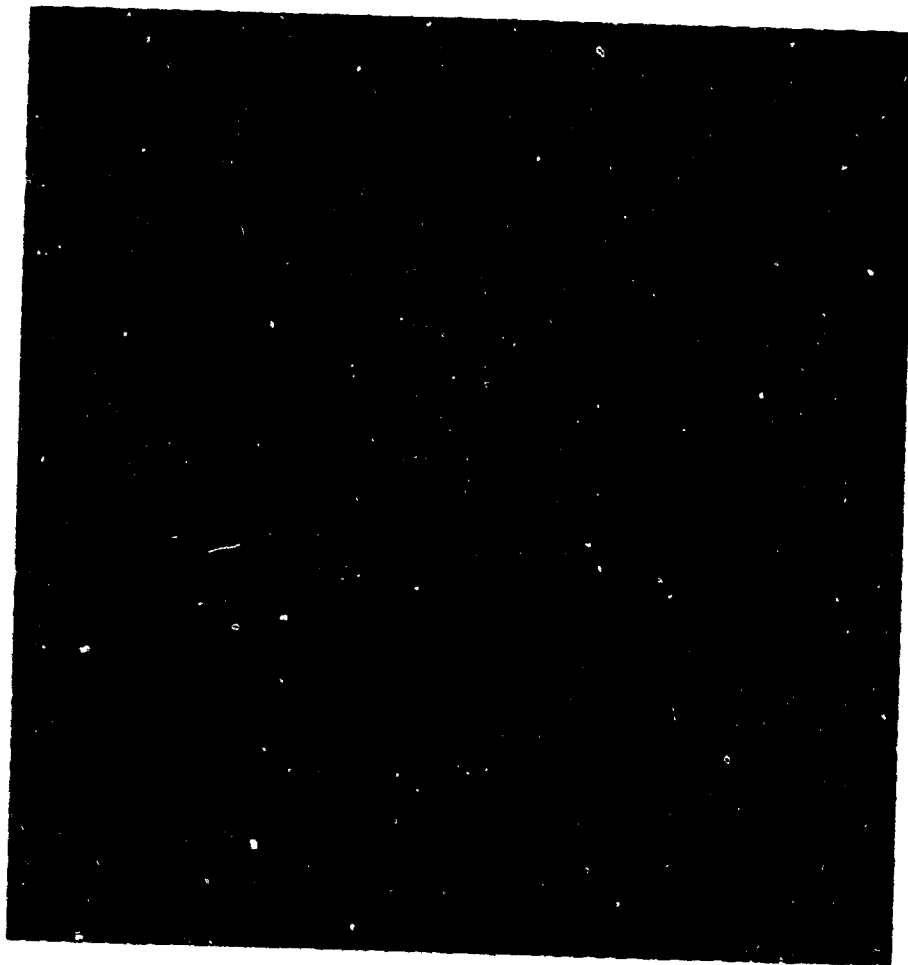
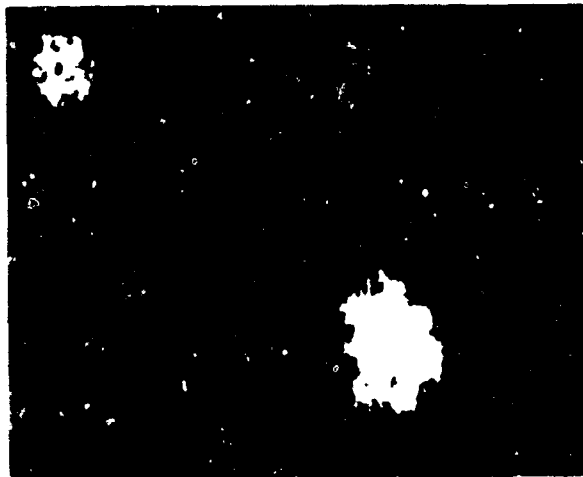
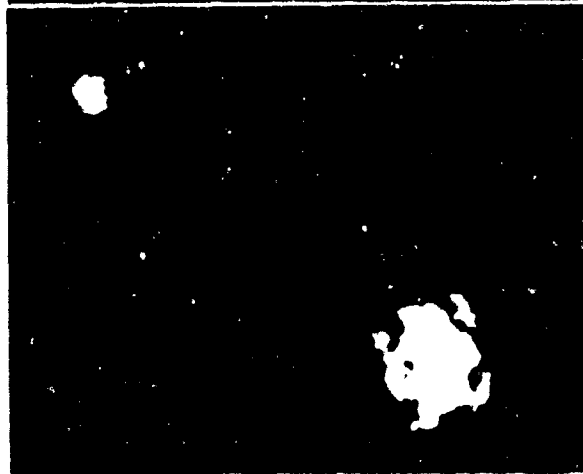

Figure 26 Hologram: Shock Waves. (The two crossing holograms are continuous patterns in an optical discontinuity. The lines do not cross in three-dimensional space; they are separated by more than 2 cm.)



(a) Hologram



(b) Reconstruction

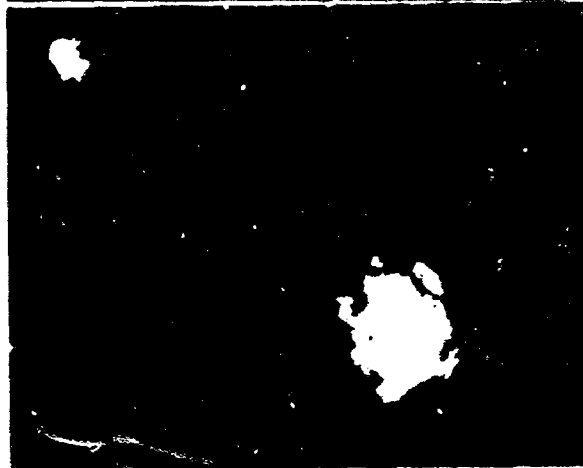

(c) Reconstruction

Figure 27. Dynamic Hologram Reconstruction

CHAPTER 12
CONCLUSIONS AND RECOMMENDATIONS

CONCLUSIONS

The basic mathematical predictions and experimental results of Parrent and Thompson provided a foundation for the practical design and synthesis of a hologram camera and reconstruction system that has been reduced to a practical operating instrument for the evaluation of explosively generated aerosols.

A new tool was developed under this contract that should contribute substantially to the art of aerosol measurement. Measurements made in situ of a considerable aerosol volume, in a period of only 20 nsec, are sufficiently fast to study the dynamic formation of aerosol clouds. The hologram camera can offer an important method of evaluating the performance of commonly used impactors and other aerosol measuring techniques that involve separation of the aerosol particles due to the anisokinetic sampling which is inherent in their principle of operation.

The original objectives of the contract were to measure particles in the expanding cloud of an explosively disseminated aerosol cloud over a particle range of 3 to 30 μ . These objectives have been met under operating conditions. During Phase I, a bench model of the hologram camera was set up, and the resolution of presized particles in the 3 to 30- μ range was demonstrated at a magnification of 10X. The theoretical requirements of film resolution were determined and verified experimentally. The requirements for spatial and temporal coherence characteristics of the illumination were computed and used as the design criteria for determining an optimum configuration for the laser collimator. A 4 x 5-in. format was selected, so that the camera would be capable of recording large aerosol volumes, and also be used with a wide variety of recording media.

The techniques and model for measuring particles at high velocities were developed in Phase II. Factors taken into consideration were the particle flow rate, particle concentration, and adequate protection from physical damage due to shock and contamination.

The assumption that particles could be recorded if the particle moved no less than one-tenth of the particle diameter during the exposure proved to be a sound

criterion, and a laser with minimum pulse length and sufficient power to expose the film was selected. Particle concentrations as high as 100,000 particles per cubic centimeter were recorded for an aerosol with a mean diameter of approximately 10μ . The limit on the concentration that can be recorded is determined by the scattering and diffraction of light in the illuminating beam that causes a loss of the valuable coherence properties of the illumination.

Optical flats, which can be readily replaced as required, were provided to protect the camera from shock and contamination. Modest amounts of particulate matter that impinge on the flats have little effect on the operation of the hologram camera because these particles reconstruct at a considerable distance away from the particles in the picture volume. The level of contamination in the test chamber caused by dissemination products, debris, and auxiliary light sources dictated the design requirements for maintaining a positive helium pressure of 5 psi within the camera and light tube.

Research in high velocity measuring techniques was materially aided by the construction of four disc test particle disseminators that aerosolized standard particles by rupturing an aluminum diaphragm with nitrogen gas at 300 psi. A .22 caliber air pistol was used to disseminate particle samples in small quantity by firing a gelatin capsule through the pistol and breaking the capsule at the muzzle against a thin wire. This pistol disseminator made possible the photographing of particles traveling at 300 fps under laboratory conditions.

The success of the early bench model of the aerosol camera suggested that the usable size range and utility of the instrument might be extended to adapt the camera for the aerosol decay studies. Accordingly, in the early stages of Phase III, the original requirements were modified to supply the necessary components to extend the capability of the instrumentation. A wider choice of lenses, a remotely operated film magazine, a shutter, and a recording capability of one picture per minute were provided. Because the original camera was designed with a modular concept, no redesign was required, and only the interchange of components was necessary.

A wide selection of lenses and film backs were designed to make definitive pictures of aerosols with mass mean diameters from 3 to 1000μ or larger. The ratio of the volume of the particles included in this range of diameters is approximately 5×10^7 . The mechanical components were constructed in accordance with

the detailed final design requirements. Included were the mechanical design of lens shock mounts, the rugged support required to hold the camera and laser in optical alignment, the remote camera control, and a precision mechanical stage for moving the hologram in three dimensions during the reconstruction process. A helium-neon gas laser was selected for the reconstruction illumination because it has excellent coherence properties and a sufficient intensity to permit Polaroid pictures of reconstructions to be made rapidly to record various dissemination states. The efforts during this phase were culminated in the fabrication of a final instrument which was delivered to the U. S. Army Edgewood Arsenal and installed under the supervision of Tech/Ops.

A thorough proof testing of all hologram camera system components was accomplished during the first week of on-site tests at the Edgewood Arsenal chamber. The magnitude of the stray light of the flash from the explosive and from auxiliary illumination was measured. Important static calibration tests were made, but the dynamic tests were marred by laser failure caused by a freak condition where a random reflection inside the laser cavity pitted the prism and the Q-switch. The offending reflecting surface was suitably masked.

A second week of on-site tests produced excellent pictures of explosively disseminated aerosol particles in situ. It proved difficult to supply precise timing pulses to synchronize the laser, so that the picture could include a portion of the leading edge of the expanding aerosol cloud. The operating technique was improved, however, (by the chamber support group) and holograms were made at any desired point in time.

RECOMMENDATIONS

Numerous disseminations have been recorded by Edgewood personnel that show excellent detail of the aerosol dissemination process and demonstrate the feasibility of the assessment of explosively generated aerosols on a routine basis, using the techniques and instrumentation system designed by Technical Operations under Contract No. DA 18-035-AMC-256(A). However, further research to develop films ideally suited for hologram photography would improve the fidelity of the pictures. For the particular requirements of explosive aerosol evaluation, a custom lens

design with the following objectives would make a lens for the coherent light hologram camera that would offer a new quality and performance level for the hologram camera:

1. A low F number lens with a minimum number of elements, for operation at one frequency, with stray light reflected from internal surfaces of 0.1% or less per surface
2. A design encompassing aberration correction for objects in the picture volume
3. The practical addition of a disposable replaceable outer element that could be changed as required.

Further research to produce films and lenses especially adapted to the requirements of hologram photography also would improve the signal-to-noise ratio of the hologram systems. (The signal component may be the amplitude and phase information from a single 3- μ particle; the noise component is the spurious amplitude and phase information from sources such as scattering from lens surfaces, variations in film thickness, and nonlinearities in film characteristics.)

To ensure the continuity of the scientific effort so that the maximum utility and benefits may be obtained from the new holographic technique, it is recommended that a program be established with the following goals to be achieved:

1. Modification of existing components to effect increased facility of operation, and augmented utility as determined by new field requirements
2. Investigation of diffraction of light by ultrasonic waves, and determination of the requirements for recording three-dimensional shock wave patterns.
3. Theoretical investigation of factors required to improve the signal-to-noise ratio, and specification of a practical program to achieve increased signal-to-noise ratio. (At the conclusion of the theoretical investigation, the contract monitor would have the option of granting approval for the practical modifications required to improve the signal-to-noise ratio.)

4. Theoretical analysis and effect of aberrations, and determination of optimum configuration. (This analysis would evaluate the factors that would compose an ideal lens design. A decision point would be presented for actual lens design if required.)
5. Theoretical investigation of the desirable film characteristics where the film is a component of a coherent system. (Immediate goals would be a linear dynamic range of 1.5 log exposure, high resolution, and uniform phase characteristics.)

REFERENCES

1. D. Gabor, *Nature* 161, 777 (1948).
2. D. Gabor, *Proc. Roy. Soc. (London)* A197, 454 (1949).
3. D. Gabor, *Proc. Phys. Soc.* B64, 449 (1951).
4. G. L. Rogers, *Proc. Roy. Soc. (Edinburgh)* A: 63, 193, (1952).
5. H. M. A. El-Sum, "Reconstructed Wavefront Microscopy" (PhD thesis, Stanford University, 1952).
6. H. M. A. El-Sum "Optical Processing of Information" (Baltimore, Md. : Spartan, 1963), p. 85.
7. A. U. Baez and H. M. A. El-Sum, "X-Ray Microscopy and Microradiography," (New York, N. Y. : Academic Press, Inc. , 1957).
8. A. Lohmann, *Optica Acta* 3, 97 (1956).
9. E. N. Leith and J. Upatnieks, *J. Opt. Soc. Am.* 52, 1123 (1962).
10. E. N. Leith and J. Upatnieks, *J. Opt. Soc. Am.* 53, 1377 (1963).
11. E. N. Leith and J. Upatnieks, *J. Opt. Soc. Am.* 54, 1295 (1964).
12. A. Vander Lugt, *Trans. IEEE IT-10*, 139 (1964).
13. G. W. Stroke and D. G. Falconer, *Phys. Letters* 13, 306 (1964).
14. G. W. Stroke and D. G. Falconer, *Symposium on Optical and Electro-Optical Information Processing Technology* (to be published, M. I. T. Press (1965)).
15. G. W. Stroke and D. G. Falconer, *Appl. Phys. Letters* 6, 201 (1965).
16. E. N. Leith and J. Upatnieks, *Scientific American* 212, 6 (1965).
17. G. W. Stroke, *Int. Sci. and Tech.*, May (1965).
18. B. J. Thompson, *Journal of SPIE* 2, 43 (1964).
19. G. B. Parrent and B. J. Thompson, *Optica Acta* 11, 183 (1964).
20. B. J. Thompson, *Japan. J. Appl. Phys.* 4 (Suppl), (1965).

REFERENCES (Cont'd.)

21. B. A. Silverman, B. J. Thompson, and J. Ward, *J. Appl. Meteorol.* 3, 792 (1964).
22. B. J. Thompson, G. B. Parrent, Jr., B. Justh, and J. Ward, Paper presented to the 237th National Meeting of the American Meteorological Society, Washington, D. C., April 19-22, 1965.
23. G. O. Reynolds, *J. Opt. Soc. Am.* 55, 595A (1965).
24. J. B. DeVelis, *J. Opt. Soc. Am.* 54, 1407A (1964).
25. M. Born and E. Wolf, "Principles of Optics," 2nd Ed. (New York, N. Y. : Pergamon Press, 1964), p. 384.
26. N. R. Kilcoyne, "A Study of the Focusing and Collimation Properties of the Pulsed Multi-Moding Ruby Laser" (M. S. thesis, Ohio State University, 1964).
27. M. J. Beran and G. B. Parrent, Jr., "Theory of Partial Coherence," (Englewood Cliffs, N. J. : Prentice Hall, Inc., 1964). p. 53.
28. J. Armstrong, *Journal of Research and Development IBM* 9, 171 (1965).
29. R. W. Meier, *J. Opt. Soc. Am.* 55, 595A (1965).
30. E. N. Leith, *Phot. Sci. and Eng.* 6, 2, (1962).

UNCLASSIFIED

Security Classification

DOCUMENT CONTROL DATA - R&D		
<i>(Security Classification of title, body of abstract and indexing annotation must be entered when the overall report is classified)</i>		
1. ORIGINATING ACTIVITY (Corporate author) Technical Operations Research Burlington, Massachusetts		2a. REPORT SECURITY CLASSIFICATION UNCLASSIFIED
		2b. GROUP N/A
3. REPORT TITLE HOLOGRAM CAMERA AND RECONSTRUCTION SYSTEM FOR ASSESSMENT OF EXPLOSIVELY GENERATED AEROSOLS		
4. DESCRIPTIVE NOTES (Type of report and inclusive dates) Final Report		
5. AUTHOR(S) (Last name, first name, initial) Zinky, William R.		
6. REPORT DATE October 1965	7a. TOTAL NO. OF PAGES 067	7b. NO. OF REFS 030
8a. CONTRACT OR GRANT NO. DA 18 035 AMC 256(A)	8b. ORIGINATOR'S REPORT NUMBER(S) Final Report	
a. PROJECT NO.		
c. Task No. TO B 65-90	8c. OTHER REPORT NO(S) (Any other numbers that may be assigned this report)	
d. Work Unit.		
10. AVAILABILITY/LIMITATION NOTICES Qualified requesters may obtain copies of this report from Defense Documentation Center, Cameron Station, Alexandria, Virginia 22314		
11. SUPPLEMENTARY NOTES	12. SPONSORING MILITARY ACTIVITY	
13. ABSTRACT This report describes the design and synthesis of a hologram camera and reconstruction system for measuring particle sizes in the 3 to 1000-u range in explosively generated aerosols. The objective was to measure a volume of high velocity particles in situ. Theoretical resolution requirements and design details concerning 10 camera configurations with magnifications from 1 to 25X, capable of resolving particles from 3.5 to 1000 u, are discussed. The design of a laser collimator to provide a 20 nsec illumination source is described. Aerosol sample volumes from 6.75 cu mm to 256 cu cm were reconstructed from individual photographs. Recommendations for further refinement of this working system are included.		
14. KEYWORDS Hologram camera Hologram reconstruction Dynamic aerosol photography Fraunhofer holograms Laser collimator		