

UNCLASSIFIED

AD NUMBER
AD474703
NEW LIMITATION CHANGE
TO Approved for public release, distribution unlimited
FROM Distribution authorized to U.S. Gov't. agencies and their contractors; Administrative/Operational Use; DEC 1965. Other requests shall be referred to Air Force Aero Propulsion Laboratory, Attn: AFPL, Wright-Patterson AFB, OH 45433.
AUTHORITY
AFAPL ltr, 12 Apr 1972

THIS PAGE IS UNCLASSIFIED

SECURITY

MARKING

The classified or limited status of this report applies to each page, unless otherwise marked.

Separate page printouts MUST be marked accordingly.

THIS DOCUMENT CONTAINS INFORMATION AFFECTING THE NATIONAL DEFENSE OF THE UNITED STATES WITHIN THE MEANING OF THE ESPIONAGE LAWS, TITLE 18, U.S.C., SECTIONS 793 AND 794. THE TRANSMISSION OR THE REVELATION OF ITS CONTENTS IN ANY MANNER TO AN UNAUTHORIZED PERSON IS PROHIBITED BY LAW.

NOTICE: When government or other drawings, specifications or other data are used for any purpose other than in connection with a definitely related government procurement operation, the U. S. Government thereby incurs no responsibility, nor any obligation whatsoever; and the fact that the Government may have formulated, furnished, or in any way supplied the said drawings, specifications, or other data is not to be regarded by implication or otherwise as in any manner licensing the holder or any other person or corporation, or conveying any rights or permission to manufacture, use or sell any patented invention that may in any way be related thereto.

SOLID FILM LUBRICATION RESEARCH

D. J. Boes
K. W. Grossett
E. S. Eber
D. Berg

Quarterly Progress Report No. 2
1 September - 1 December 1965

Contract No. AF 33 (615)-2618
Project 3145 - Task 314502

Westinghouse Electric Corporation
Research Laboratories
Pittsburgh, Pa. 15235

For

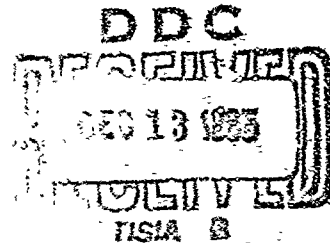

Air Force Aero Propulsion Laboratory
Research and Technology Division
ATTN: ASSL
Wright-Patterson Air Force Base, Ohio 45433

424303

**Best
Available
Copy**

SOLID FILM LUBRICATION RESEARCH

D. J. Boes
K. W. Grossett
E. S. Bober
D. Berg

Quarterly Progress Report No. 2
1 September - 1 December 1965

Contract No. AF 33 (615)-2618
Project 3145 - Task 314502

Westinghouse Electric Corporation
Research Laboratories
Pittsburgh, Pa. 15235

For

Air Force Aero Propulsion Laboratory
Research and Technology Division
ATTN: APFL
Wright-Patterson Air Force Base, Ohio 45433

FOREWORD

This report was prepared by the Westinghouse Electric Corporation, Westinghouse Research Laboratories, Insulation and Chemical Technology Department, Beulah Road, Churchill Borough, Pittsburgh, Pennsylvania 15235, under USAF Contract No. AF 33(615)-2618. The contract was initiated under Project 3145, "Dynamic Energy Conversion Technology," Task 314502, "Solar Dynamic Power Units." The contract is being continued under Project 8128, "Power Conversion Conditioning and Transmission Technology," Task 812802, "Mechanical Power Transmission and Control" and Project 3044, "Aerospace Lubrication," Task 304402, "Advanced Propulsion Lubrication Engineering." The work is being administered under the direction of the Air Force Aero Propulsion Laboratory, Research and Technology Division, with Mr. John L. Morris acting as project engineer. Accordingly, questions relative to this work may be directed to:

Air Force Aero Propulsion Laboratory
ATTN: AFFL (Mr. John L. Morris)
Wright-Patterson Air Force Base, Ohio 45433

This report covers work conducted from 1 September to 1 December 1965.

Approved for:
Westinghouse Electric Corporation

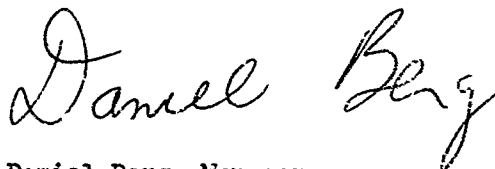

Daniel Berg, Manager
Physical and Inorganic Chemistry-R&D

NOTICES

When U. S. Government drawings, specifications, or other data are used for any purpose other than a definitely related Government procurement operation, the Government thereby incurs no responsibility nor any obligation whatsoever, and the fact that the government may have formulated, furnished, or in any way supplied the said drawings, specifications, or other data, is not to be regarded by implication or otherwise, or in any manner licensing the holder or any other person or corporation, or conveying any rights or permission to manufacture, use, or sell any patented invention that may in any way be related thereto.

Qualified users may obtain copies of this report from the Defense Documentation Center.

Defense Documentation Center release to the Clearinghouse for Federal Scientific and Technical Information (formerly OTS) is not authorized. Foreign announcement and dissemination by the Defense Documentation Center is not authorized. Release to foreign nations is not authorized.

DDC release to OTS is not authorized in order to prevent foreign announcement and distribution of this report. The distribution of this report is limited because it contains technology identifiable with items on the strategic embargo lists excluded from export or re-export under U. S. Export Control Act of 1949 (63 STAT. 7), as amended (50 U.S.O. App. 2020, 2031), as implemented by AFR 400-10.

Copies of this report should not be returned to the Research and Technology Division unless return is required by security considerations, contractual obligations or notice on a specific document.

This report is being published prior to Air Force review. The publication of this report, therefore, does not constitute approval by the Air Force of the findings or conclusions contained herein. It is published for the exchange and stimulation of ideas.

ABSTRACT

This report describes progress during the second quarterly period in a program designed to develop a solid film lubricated ball bearing system capable of operation under high speed, high temperature oxidizing conditions. The program's ultimate goal is long-term ball bearing operation at 1500°F - 30,000 rpm, under atmospheric conditions simulating sea-level to 200,000 ft. altitudes. A second program objective is to provide parametric design data relating the operating life, load, bearing size, speed, temperature and environment of these bearing systems.

In the material development area, this report describes further progress in optimizing the properties of unique self-lubricating composites that are both physically and chemically capable of functioning as load-bearing surfaces in an extreme temperature-oxidizing environment.

The composites are composed of solid lubricants; such as WSe_2 , $MoSe_2$, and WS_2 that have been combined with gallium or various gallium alloys.

In the area of functional testing, the results of initial high speed tests on ball bearings equipped with retainers fabricated from these composites are described.

I. Introduction

Proper lubrication is a prime requisite for the successful operation of any load-bearing surface that undergoes a relative motion between itself and a second component of a system. But, when the load-bearing surface is exposed to a high-temperature oxidizing environment, the lubrication problem is greatly complicated by the effect of environment on the lubricant. Two major effects result from such an environment: First, there is a loss of conventional lubricants through evaporation and chemical decomposition. Secondly, through an oxidation process, solid lubricants are transformed to relatively abrasive metal oxides. The resulting substantial increase in friction eventually brings about the catastrophic failure of the load-bearing system by means of a wear mechanism.

This program is designed to develop solid film lubrication systems capable of 500 to 1000 hour operation in atmospheres characteristic of those from sea level to 200,000 ft., at temperatures from -45 to +1500°F, and at speeds approaching 30,000 rpm. The program has two major objectives:

1. To optimize the physical properties of certain unique composites and thereby materials that are both physically and chemically capable of functioning as self-lubricating load-bearing surfaces in an extreme-temperature oxidizing environment. A unique technique discovered at the Westinghouse Research Laboratories for imparting mechanical strength and oxidation resistance to composites of high solid lubricant content is being investigated in attempts to achieve this goal.

2. To functionally evaluate the performance of high-speed ball bearings utilizing these composite as self-lubricating retainers. Parametric design data relating the operating life, load, bearing size, speed, temperature, and atmospheric environments will be obtained.

The materials optimization portion of the overall effort will emphasize the evaluation of candidate materials with respect to friction coefficients, wear resistance, mechanical strength and oxidation resistance. The effect of elevated temperature, oxidizing environments on friction-wear characteristics will also be determined.

The functional test portion of the program, in a step-wise approach, is designed to demonstrate a minimum operating life of 200 hours at successively higher temperatures of 600, 900, 1200 and 1500°F. All systems will have the following design objectives: (1) speed, 30,000 rpm; (2) load, 100 lb. radial/100 lb. thrust; (3) atmosphere, sea level to 200,000 ft.; and (4) bearing size, 204 and 207.

A work schedule for the over-all program to 31 May 1967 is given in chart form in Fig. 1. This schedule gives the major tasks and shows when the work is to be performed. Periodic reviews of this plan will be performed to determine if certain modifications would better accomplish program objectives.

II. Experimental

A. Material Development and Optimization

During the first quarter of this program (1) the optimum fabricating conditions and curing cycle for the tungsten diselenide-gallium/indium composite were established. In addition, the effect of the alloy 75 Ga-25 In concentration on the physical and chemical properties of four solid lubricants was determined. During this past quarter this optimization program was continued in the following areas:

1. Effect of Amalgamator type
2. Effect of pre-curing amalgamated powder before fabrication
3. Effect of GaSn (90-10 wt %) concentration on lubricant amalgam
4. Effect of metal fillers on composite properties.
5. Differential thermal analyses of the WSe₂ amalgam.

The results of the efforts in each of these areas are described below.

1. Effect of Amalgamator Type

The objective of this task was to determine the effect of amalgamator type on the friction, wear, mechanical strength and oxidation resistance of solid lubricant amalgams. An evaluation of amalgamator effect on these parameters was made for three solid lubricants: tungsten diselenide, tungsten disulphide and molybdenum diselenide. The amalgamator concentration used in these experiments was 30% (wt.); i.e., the optimum determined in Task 2 (1). The results of these experiments are shown in Tables I and II. It will be noted that the tungsten diselenide-gallium/indium combination continued to provide the best mechanical properties with a compressive strength of 25,500 psi. In addition, the WSe₂-GaIn amalgam exhibits combined friction-wear characteristics that are superior to all other amalgams evaluated for any lubricant.

For the following reasons, therefore, the 70% WSe₂ - 30% GaIn amalgam was selected as the first composition to be functionally evaluated in the test program:

- a. optimum combination of friction-wear characteristics at room temperature,
- b. maximum strength,
- c. excellent oxidation resistance to at least 900°F, and
- d. good friction-wear characteristics at 600 F.

In Table III a complete description of pertinent physical properties of the 70% WSe₂ - 30% GaIn composite are presented. These include shear, tensile, compression, and coefficients of thermal expansion. Figure 2 gives a detailed drawing of the specimen used to determine tensile strength. Compression and shear tests are performed on specimens 1/2" dia. x approx. 1" long, while thermal expansion coefficients employ 1/8" dia. x 1" long specimens.

In Fig. 3 (top), the type of film deposited by the 70/30 WSe₂-GaIn composite on an M-50 tool steel disc is shown. The film was generated during a typical 30 minute friction-wear test with the specimen rotating at 70 fpm under a 1000 psi load. Half of the film was removed by lightly polishing the disc with a 4-0 polishing paper. The center and bottom photographs are magnifications (50x) of the film and that portion of the disc from which the film was removed. It will be noted that no scarring or wear of the tool steel is experienced during the 30 minute test.

2. Pre-Curing of Amalgamated Powder

In an effort to improve the mechanical properties of WSe₂-GaIn and WS₂-Ga amalgams, a series of experiments were performed in which the solid lubricant powder - after amalgamation with 20% GaIn - was cured in the powdered form for the 200°C - 15 hour portion of the cycle. Subsequent to this cure, additional quantities of gallium-indium were added to the partially cured powder and the pellet formed and cured in the normal manner. Friction, wear and mechanical properties were then measured on each pellet. The results are given in Table IV and show that this technique does offer some improvement in the mechanical properties of the solid lubricant amalgams, particularly in the case of tungsten disulphide. The degree of improvement is not sufficient, however, to warrant additional effort unless future work demonstrates that the use of WS₂ is more desirable than WSe₂.

3. Effect of GaSn Concentration on Lubricant Amalgams

In Table I it will be noted that use of the gallium-tin alloy in concentrations of 30% (wt.) provided WSe₂ and WS₂ composite amalgams of reasonably good mechanical properties and excellent lubricating ability. As part of the continuing effort to improve composite mechanical properties, a series of experiments were performed to determine the effect of GaSn concentration on the physical and chemical properties of WSe₂, WS₂ and MoSe₂ amalgams. Solid lubricant amalgams containing 10, 20, and 30% (wt.) gallium-tin alloy were prepared and evaluated with respect to friction, wear, compressive strength and oxidation resistance. The results of these experiments are given in Tables V and VI. It will be noted that use of the GaSn alloy did not significantly improve the mechanical properties of amalgams utilizing WS₂ as the solid lubricant. Tungsten and molybdenum diselenides, however, responded to amalgamation with GaSn in much the same manner as with GaIn, giving compressive strengths of 24,700 and 28,150 psi respectively in the 80-20 (wt. %) compositions. Oxidation resistance of these materials was excellent when a concentration of at least 20% alloy was incorporated in the lubricants.

In view of the lower cost of tin as opposed to indium, the tungsten and molybdenum diselenide-gallium/tin amalgams warrant further investigation at some future date, particularly with respect to the effect of tin content on composite properties. For the present, however, initial functional tests will be made using the WSe_2 -GaIn amalgam, primarily because of its lower friction coefficients.

4. Effect of Metal Fillers on Composite Properties

Initial efforts in this area concentrated on the effect of pressing conditions on metal-filled composite properties. A composition of 70 (wt) % WSe_2 /GaIn - 30% Ag was selected. After amalgamating the solid lubricant, the appropriate amount of silver powder (-325 mesh) is added and the blend tumble mixed until a relatively homogenous distribution of the components is achieved. A combination of four pressing loads at three pressing temperatures was investigated. Subsequent to fabrication, each specimen was cured in air for 15 hours at 200°C, 8 hours at 350°C and 4 hours at 400°C. The results of friction, wear and mechanical tests on the pellets are given in Table VII. It will be noted that the use of silver as a filler in the optimum WSe_2 mix provided, in all cases, higher compressive strengths than the unfilled amalgam. Except for the lowest pressing load at 150°C, severe wear was experienced, however, when pressing temperatures > 25°C were employed. In addition, friction coefficients of these composites were higher than unfilled amalgams. Based on their combined performance with regard to friction, wear and compressive strength, two specimen conditions were selected for further evaluation. These are:

(a) 25°C - 75000 psi pressing load
(Compressive = 36,800 psi)

(b) 150°C - 25,000 psi pressing load
(Compressive = 34,200 psi)

A second series of experiments using WS_2 -Ga as a substitute for WSe_2 -GaIn was performed with Ag again being used as the filler. The results of these experiments are given in Table VIII and again demonstrate that a metal filler in concentrations of at least 30% (wt.) not only causes a sharp increase in mechanical strength but also in wear rate. The tungsten disulphide composites, however, retained their characteristically low friction coefficients. Because of their high wear characteristics, filled WS_2 amalgams cannot yet be considered as candidate materials for functional tests.

5. Differential Thermal Analyses

In an attempt to more clearly understand the mechanism involved in the amalgamation of a solid lubricant with gallium or one of its alloys, a series of differential thermal analyses were performed. The experiments

were conducted in a well insulated oven in which (1) the temperature differential between a "standard" [cured WSe_2 -GaIn (70-30)] and the test specimen and (2) oven temperature were recorded on an x-y recorder. The results of two such analyses are shown in Fig. 4; the x-axis recording oven temperature and the y-axis temperature differential. The top curve shows the temperature differential between a cured and uncured WSe_2 -GaIn (70-30 wt. %) amalgam as a function of oven temperature over a 550°C range. The lower trace illustrates the results when both pellets have been cured prior to the experiment. It is clear from these experiments that two distinct, exothermic reactions occur during the curing cycle of composite amalgams. The first is initiated when a temperature of 180 - 200°C is reached, while the second occurs between 420 - 450°C . Three important points have thus been brought out by these experiments. First, it can now be stated that the oxidation resistance imparted to various solid lubricants by the "amalgamation" technique is quite probably due to a chemical interaction between the gallium alloy and the solid lubricant; not to a mere physical coating of solid lubricant particles with an oxidation resistant material. Secondly, it points out the necessity of continuing the curing cycle for these composite amalgams to at least 500°C in order to bring about the second reaction. (Recent work indicates that the piece is not dimensionally stable until it is exposed to at least 500°C) Finally, the technique has become a useful tool in establishing at least the optimum temperatures for the curing cycle of future experimental compositions.

III. Test Programs

Construction of all test facilities was completed during the past quarter. A total of twelve stations are available for functionally evaluating 204 and 207 bearings at speeds of 10,000, 20,000, and 30,000 rpm. Four stations operate at each speed level, with one of the four capable of simulating an altitude of 200,000 ft. Figure 5 is an overall view of the test laboratory with one vacuum shroud and one oven installed for illustration purposes. All walls are insulated with Tectum to reduce noise level to a minimum. Figures 6 and 7 are close-up views of the 20,000 and 30,000 rpm spindles respectively. Spindle bearings and drive motors are water cooled. The 10,000 and 20,000 rpm spindles are identical with the exception of drive motors.

A total of seven tests have thus far been run on the 10,000 rpm facilities at room temperature and a variety of thrust-radial load combinations. One 20,000 rpm test has been initiated. Before installation in test facilities, the bearings are prepared in the following manner:

1. Cage removal and initial degreasing in trichlorethylene.
2. Rinse in fresh trichlorethylene.
3. Final, ultra-sonic cleaning in ethyl alcohol.

4. Component weighing to ± 0.0005 gm.
5. Composite cage installation and storage in vacuum dessicator until test.

Test bearing cages are machined from 1 1/2" O.D. x 3/4" I.D. rings fabricated from the WSe₂/GaIn amalgam in a carbide lined ring die. Figure 8 is a composite photograph of the cured ring, the machined retainer, and the test bearing after cage installation. The cage design employed in the first four 10,000 rpm tests is shown in Fig. 9.

(It will be noted that this is an outer race riding cage. It is being used for initial tests to gain experience with test facility performance and evaluate initial cage compositions. Functional testing on the actual test bearing configuration - inner race riding - will be initiated in the next quarter. Bearing delivery dates of December 11 have been promised.)

Due to the outer race riding cage design of the bearings now being used, the self-lubricating composite cage could not be reinforced with a stainless shroud over its entire outer surface. Therefore, a partial shroud was employed that encompassed only that portion not riding on the inner diameter of the outer race. The results of the first four tests are given in Table IX and are summarized briefly below.

Run #1 - A total life of 22 hours was achieved under the maximum radial and thrust loads called for by the program. At this point, fracture occurred in the unshrouded portion of the cage as evidenced by a sharp rise in running temperature. Catastrophic failure did not occur; the bearing continuing to operate at a slightly higher temperature until manual shutdown. During this final portion of the test, however, the balls in the areas of cage fracture were able to wear against one another, thus causing ball wear as noted.

Run #2 - A duplicate of run #1 was repeated with a slightly modified shroud design and resulted in a doubling of life. The same mechanism of failure-cage fracture in unshrouded portion and ball wear before manual shutdown--occurred in this case.

Run #3 - Both radial and thrust load were reduced by 50%. The result was an increase in life to 75 hours before cage fracture in unshrouded area. This test is significant in that - although cage fracture occurred - the ball pockets remained intact and prevented the balls from rubbing against one another. It will be noted that no measurable bearing wear occurred in this test during a total running time of 98 hours. This result indicates strongly that adequate lubrication is being furnished by the composite amalgam and bearing failure is due only to a lack of mechanical strength in the cage, particularly in tension.

Run #4 - Under a 10# radial load and a 50# thrust load, a running time of 85 hours was achieved before cage rupture. A failure mechanism identical to runs 1 and 2 applied.

In view of the fact that cage fracture consistently occurred in the unshrouded portion of the cage, it was decided to repeat the above tests on bearings employing an inner race riding cage. In this way, a full shroud could be employed. Off the shelf angular contact bearings of ABEC-1 rating were used. The results of these tests are given in Table X. No cage failures were experienced over the 100 hour test period under all load conditions studied. After test the bearings were in excellent condition, as shown in Fig. 10, and quite probably could have operated over a second 100 hour period. The 21,000 rpm test (Run #8) operated well for a period of 5 hours before seizure of the facility bearings occurred. Tests on this bearing will be continued subsequent to a successful solution to the facility bearing problem.

The moderate wear encountered in the balls and inner race of bearings 5 and 6 is believed caused by the fact that the bearings are non-precision and do not conform to the optimum design established by the bearing analysis (1).

Conclusions:

The following conclusions can be drawn from data resulting from the program to date:

1. The 75/25 (wt. %) GaIn alloy in concentrations of 20 to 30% (wt.), provides composite amalgams having the best combination of physical and chemical properties.
2. The WSe_2 composite amalgams, when formed with the GaIn alloy, are superior to all others tested when compared to the following parameters:
 - a. room temperature and 600°F friction-wear characteristics
 - b. Mechanical strength
 - c. Oxidation resistance
3. Pre-curing amalgamated lubricant in the powdered form followed by additional GaIn additions and subsequent pressing provides some improvement in the mechanical properties of WS_2 amalgams. The degree of improvement is not sufficient, however, to warrant additional work at this time.
4. A 90/10 (wt.%) GaSn alloy provides WSe_2 and $MoSe_2$ composite amalgams having oxidation resistance and mechanical strengths equivalent to the GaIn counterparts.
5. The use of silver as a filler in composite amalgams results in a 50% improvement in composite mechanical properties.

Friction coefficients of filled composites were also higher.

6. Differential thermal analyse on uncured lubricant amalgams strongly indicate that two distinct, exothermic reactions occur during the curing cycle between the solid lubricant and gallium alloys.
7. Seven functional tests at 10,000 rpm on ball bearings equipped with self-lubricating composite amalgam cages have been performed. The results demonstrate the feasibility of operating this bearing system for a period of at least 100 hours under a load condition of 100# thrust - 100# radial.

Future Work

During the next quarter, studies on the use of metal fillers in the composite amalgams will be continued. Metals under consideration at this time are silver, copper, and their alloys.

In addition, attempts to utilize tungsten disulphide amalgams will continue because of their desirable friction and wear characteristics.

Finally, the test program will be accelerated. Tests at 350 and 600°F will be initiated using a modified cage design for the Barden M-50 bearing. Evaluation of various facility bearing designs and lubricants will continue in order to get the 20,000 and 30,000 rpm spindles operational.

REFERENCES

1. Boes, D. J., Grossett, K. W., Bober, E. S. and Berg, D., "Solid Film Lubrication Research," Quarterly Progress Report No. 1, Contract No. AF 33(615)-2618.
2. Boes, D. J. and Bowen, P. H., "Friction-wear Characteristics of Self-Lubricating Composites Developed for Vacuum Service," ASLE Trans. 6:192-200 (1963).
3. Boes, D. J., "New Solid Lubricants: Their Preparation, Properties and Potential for Aerospace Applications," IEEE Trans., Vol. AS-2, No. 2, April 1964.

TABLE I - Effect of Amalgamator Type on
Physical Properties of Solid Lubricant Amalgams
Composition (wt.%) 70% Lubricant - 30% Alloy

Lubricant	Alloy Comp. - wt. %		Friction Coefficient*		Wear Rate - gm/hr. #		Compressive Strength - psi
	Ga	In Sn Ag	500 psi	1000 psi	500 psi	1000 psi	
WSe ₂	75	25	.07	.06	.002	.004	25,500
	100	--	.08	.06	.008	.004	10,950
	20	60 20	.17	.09	.002	.006	9,450
	94	-- 6	.09	.08	.002	.004	5,850
WS ₂	90	-- 10	.11	.07	.008	.006	16,950
	75	25	.05	.05	.006	.004	10,600
	100	--	.10	.07	.006	.004	8,000
	20	60 20	.23	---	2.60	---	1,825
MoSe ₂	94	-- 6	.07	.04	.004	.005	8,925
	90	-- 10	.08	.08	.004	.004	9,500
	75	25	.12	.12	.014	.008	7,900
	100	--	.10	.09	.010	.008	7,900
	20	60 20	.16	.14	.008	.004	6,400
	94	-- 6	.10	.09	.012	.010	6,200
	90	-- 10	.18	.17	.002	.008	8,650

* - Versus M-50 tool steel (58-60 R_c) @ 70 FPM
Specimens pressed @ 25 TSI - Room Temperature
Cured @ 220C - 15 hours; 350C - 8 hours

TABLE II - Effect of Amalgamator Type on Oxidation Resistance of WSe₂, WSP and MoSe₂ Amalgams
Composition (Wt.%) - 70% Lubricant - 30% Alloy

Lubricant	Alloy Comp. - Wt. %		Initial Wt. Grams	Weight Change (gms. x 10 ⁻³) After 30 min. at each temperature - °F							Cumulative Wt. Change gms. x 10 ⁻³
	Ga	In Sn Ag		300	400	500	600	700	800	900	
WSe ₂	75	25	15.938	-1	NC*	NC	NC	NC	NC	NC	-1
	100	--	14.999	NC	NC	-1	NC	-2	NC	NC	-3
	20	60	15.457	-7	-3	-5	-7	NC	3	2	-17**
	94	--	15.793	NC	NC	-1	NC	NC	NC	-1	-2
	90	--	17.863	NC	-1	NC	NC	NC	NC	-1	-2
WSP	75	25	8.279	0	-1	-	-	1	-1	-	0
	100	--	13.402	-2	NC	-1	NC	NC	-1	-4	-8
	20	60	13.333	-12	-10	-6	-2	-17	-21	-16	-84**
	94	--	11.265	-1	-1	-1	NC	NC	NC	NC	-3
	90	--	9.138	-1	1	NC	-1	NC	2	NC	1
MoSe ₂	75	25	8.793	NC	NC	NC	2	NC	-1	NC	-1
	100	--	10.336	NC	-1	NC	NC	-3	-4	-15	-23
	20	60	9.202	NC	NC	-1	2	-1	-3	-6	-9
	94	--	9.672	NC	-1	NC	NC	-2	-3	-9	-15
	90	--	12.408	-1	NC	NC	NC	-1	NC	-1	-3

* - No Change

** - Pellet bled slightly during exposure indicating incomplete amalgamation.

TABLE III

Physical Properties of Composite Amalgam
Used in Initial Functional Tests

Composite -----Tungsten Diselenide/Gallium-Indium Amalgam
 Fabrication -----Room Temperature - 50,000 psi - double action die
 Curing -----15 hrs.- 200°C
 (Air Atmosphere) ----- 8 hrs.- 350°C
 ----- 8 hrs.- 500°C

Friction Coefficient
 (80°F 70 fpm) 500 psi -----0.08
 (80°F 70 fpm) 1000 psi -----0.07
 (600°F 140 fpm) 500 psi -----0.06

Wear Rate - gm./hr.
 (80°F 70 fpm) 500 psi -----0.002
 (80°F 70 fpm) 1000 psi -----0.004
 (600°F 140 fpm) 500 psi -----0.012

Tensile Strength - psi ----- 2,300
 Shear Strength = psi ----- 2,600
 Compressive Strength - psi -----25,500
 Coef. Thermal Expansion ----- 5×10^{-6}
 (in./inch °F)
 Shore Hardness -----55-57

TABLE IV
 Effect of Pre-Curing Amalgamated Powder
 on
Physical Properties of Solid Lubricant Amalgams

Pellet Identification and Composition	Friction Coefficient		Wear - gms./hr.		Compressive Strength
	500 psi	1000 psi	500 psi	1000 psi	
WSe ₂ -GaIn(80/20)	.18	.22	.008	.004	18,600
WSe ₂ -GaIn(80/20)+2%GaIn	.15	.20	.004	.006	13,500
WSe ₂ -GaIn(80/20)+5%GaIn	.13	.08	.002	.003	25,000
WSe ₂ -GaIn(80/20)+10%GaIn	.07	.05	.002	.008	11,150

WS ₂ -Ga(80/20)	.12	.12	.002	.004	13,950
WS ₂ -Ga(80/20)+5%Ga	.10	.10	.002	.002	15,250
WS ₂ -Ga(80/20)+10%Ga	.07	.11	.002	.002	13,950

All pellets pressed @ 50,000 psi - R. T. & DbL. Action
 then cured -- 15 hours @ 200°C, 8 hours @ 350°C, 8 hours @ 500°C.

TABLE V

Effect of Gallium-Tin* Concentration
on
Physical Properties of Lubricant Amalgams

Composition wt. %	Friction Coefficient		Wear - gm./hr.		Compressive Strength psi
	500 psi	1000 psi	500 psi	1000 psi	
90 WSe ₂ -10 GaSn	0.16	0.12	0.01	0.006	15,700
80 WSe ₂ -20 GaSn	0.14	0.14	0.001	0.002	24,700
70 WSe ₂ -30 GaSn	0.11	0.07	0.008	0.006	16,950
90 WS ₂ -10 GaSn	0.12	0.09	0.02	0.02	10,900
80 WS ₂ -20 GaSn	0.18	0.15	0.002	0.002	6,850
70 WS ₂ -30 GaSn	0.08	0.08	0.004	0.004	9,500
90 MoSe ₂ -10 GaSn	0.27	0.18	0.02	0.02	12,950
80 MoSe ₂ -20 GaSn	0.20	0.17	0.002	0.004	28,150
70 MoSe ₂ -30 GaSn	0.18	0.17	0.002	0.008	8,650

* - 90% Gallium (wt.%)
10% Tin

TABLE VI
 Effect of GaSn* Concentration
 on
Oxidation Resistance of Lubricant Amalgams

Composition wt.%	Wt. Loss (gms. x 10 ⁻³) After 1/2 Hour @ Temperature °F						
	300	400	500	600	700	800	900
90 WSe ₂ -10 GaSn	N.C.	1	7	1	1	- 4	N.C.
80 WSe ₂ -20 GaSn	N.C.	N.C.	N.C.	N.C.	N.C.	N.C.	N.C.
70 WSe ₂ -30 GaSn	N.C.	N.C.	N.C.	N.C.	N.C.	N.C.	- 2
90 WS ₂ -10 GaSn	-4	3	-5	-2	-2	10	3
80 WS ₂ -20 GaSn	N.C.	N.C.	N.C.	N.C.	N.C.	N.C.	N.C.
70 WS ₂ -30 GaSn	N.C.	N.C.	N.C.	N.C.	N.C.	N.C.	N.C.
90 MoSe ₂ -10 GaSn	-4	N.C.	2	-2	-7	-22	-18
80 MoSe ₂ -20 GaSn	N.C.	N.C.	N.C.	N.C.	N.C.	N.C.	N.C.
70 MoSe ₂ -30 GaSn	-1	N.C.	N.C.	N.C.	-1	N.C.	- 2

* - 90% Gallium (Wt.%)
 10% Tin

TABLE VII

Physical Properties of Silver-Filled WSe₂ Amalgams
70% (wt.) WSe₂/GaIn - 30% Ag

Pressing Temp. - °C	Conditions Pressure - psi*	Friction Coefficient		Wear - gm./hr.		Compressive Strength psi
		500 psi	1000 psi	500 psi	1000 psi	
25	25,000	0.21	0.16	0.016	0.014	Broke in holder 31,600 36,800 28,100
	50,000	0.15	0.15	0.004	0.002	
	75,000	0.15	0.12	0.004	0.004	
	100,000	0.12	0.14	0.004	0.002	
150	25,000	0.17	0.12	0.004	0.002	34,400 37,200 32,500 28,500
	50,000	0.21	0.15	0.08	0.03	
	75,000	0.11	0.17	0.08	0.04	
	100,000	0.18	0.19	0.02	0.07	
250	25,000	0.23	0.15	0.04	0.1	47,700 51,200 38,000 49,300
	50,000	0.17	0.13	0.07	0.1	
	75,000	0.09	0.13	0.09	0.1	
	100,000	0.13	0.18	0.10	0.1	

Five-Minute Hold @ Temperature & Pressure

250	25,000	0.15	0.12	0.03	---	24,600 23,000 26,700 22,250
	50,000	0.10	0.12	0.03	0.05	
	75,000	0.14	0.15	0.03	---	
	100,000	0.13	0.13	0.006	0.004	

* - 15 second hold unless otherwise specified.

TABLE VIII

Physical Properties of Silver-Filled WS₂ Amalgams
 70%(wt.) WS₂/Ga. - 30% Ag

Pressing Conditions Temp., -°C	Pressure-psi*	Friction Coefficient		Wear - gm./hr.		Compressive Strength psi
		500 psi	1000 psi	500 psi	1000 psi	
25	25,000	---	0.06	----	0.11	21,100
	50,000	---	0.05	----	0.06	23,550
	75,000	---	0.06	----	0.04	18,100
	100,000	---	0.07	----	0.04	29,800
150	25,000	0.07	0.05	0.022	0.022	15,200
	50,000	0.06	0.05	0.01	0.016	29,400
	75,000	0.07	0.04	0.014	0.016	22,700
	100,000	0.05	0.04	0.018	0.018	29,300
250	25,000	---	0.06	----	0.012	15,250
	50,000	0.09	0.08	0.002	0.01	15,450
	75,000	0.08	0.07	0.004	0.01	12,050
	100,000	0.07	0.15	0.002	0.003	18,400

* - 15-second hold

TABLE IX

Functional Test Results
High Speed Bearing Tests - Room Temperature
Outer Race Riding Cage

Run#	Load-lbs.		Life-hrs	Avg. Running Temp.	Speed-RPM	Bearing Weight Change-gms		Operation After Fracture-hrs	Total Running Time-hrs	Comments	
	Radial	Thrust				Outer	Inner				Balls#
1	100	100	22	230°F	10,600	-0.005	+0.001	-0.0/5	6.5	28.5	Balls wore against one another after cage fracture.
2	100	100	44	185	10,900	+0.002	-0.002	-0.103	10	54	Same as above.
3	50	50	75	150	10,900	0.000	0.000	+0.001	13	98	Balls prevented from wearing against one another.
4	10	50	85	150	10,900	-0.003	0.000	-0.025	15	100	Balls wore against one another after cage fracture.

* - Cumulative - 7 Balls

TABLE X

Functional Test Results
 High Speed Bearing Tests - Room Temperature
 Inner Race Riding Cage

Run No.	Load-lbs. Radial Thrust	Life-hrs	Avg. Running Temp. °F	Speed-RPM	Bearing Weight Change-gms			Operation After Cage Fracture-hrs	Total Running Time-hrs	Comments
					Outer	Inner	Balls			
5	100	100	165	10500	+0.002	-0.026	-0.023	-1.1	No Fracture	100 Smooth Operation
6	50	100	130	10500	+0.249	+0.149	-0.112	-0.54	No Fracture	100 Smooth Operation
7	10	100	93	10500	-0.091	+0.051	+0.001	-0.62	No Fracture	100 Smooth Operation
8	50	> 5	190	21000	Bearing Did Not Fail - Test Stopped Due to Facility Erg. Failure					

* Cumulative - 9 Balls.

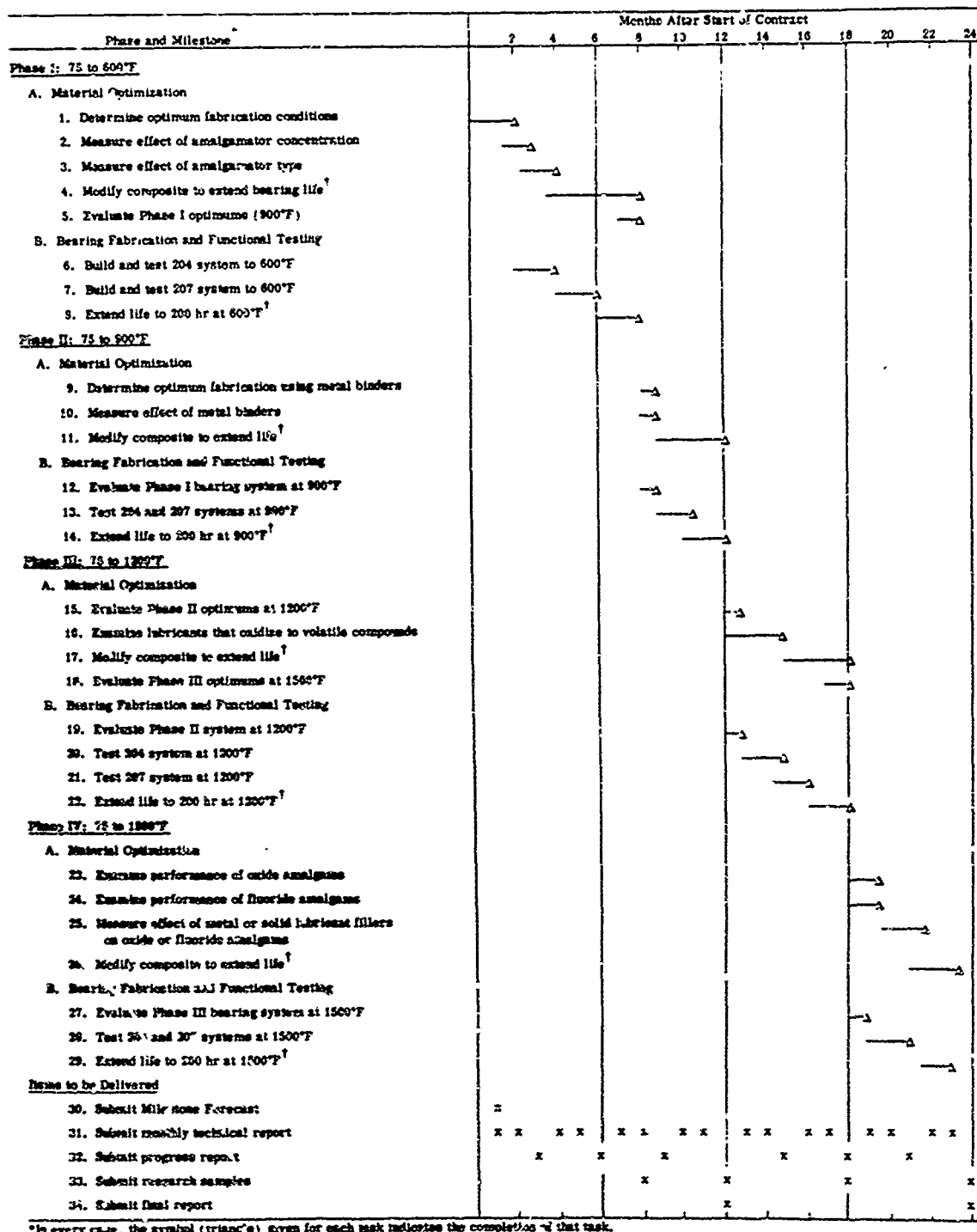

*In every case, the symbol (triangle) given for each task indicates the completion of that task.
 †Known to be pushing, the state of the art.

Figure 1—Approximate program schedule and milestone forecast.

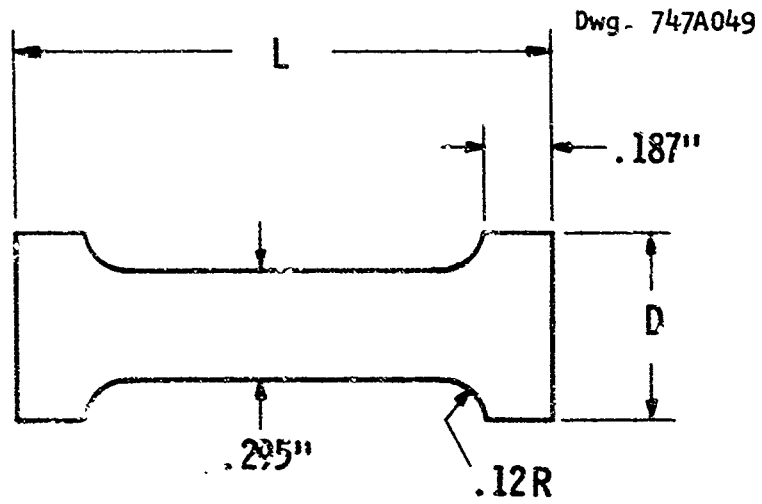

L = Length of Slug Supplied (Approx. 1.25 to 1.50 inch)
D = Diameter of Slug Supplied (Approx. 0.50 inch)

Fig. 2—Special tensile specimens

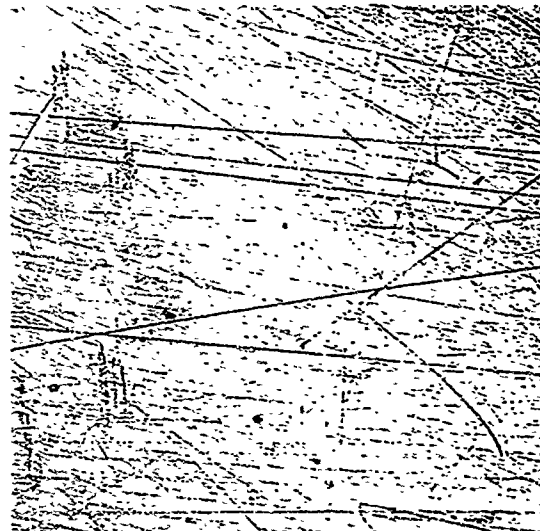

Fig. 3--Top-M-50 tool steel disc with portion of lubricant film removed 3 X
Middle- Macro Photograph of film - 50 X
Bottom- Macro photograph of surface after film removal with 40
polishing paper - 50 X

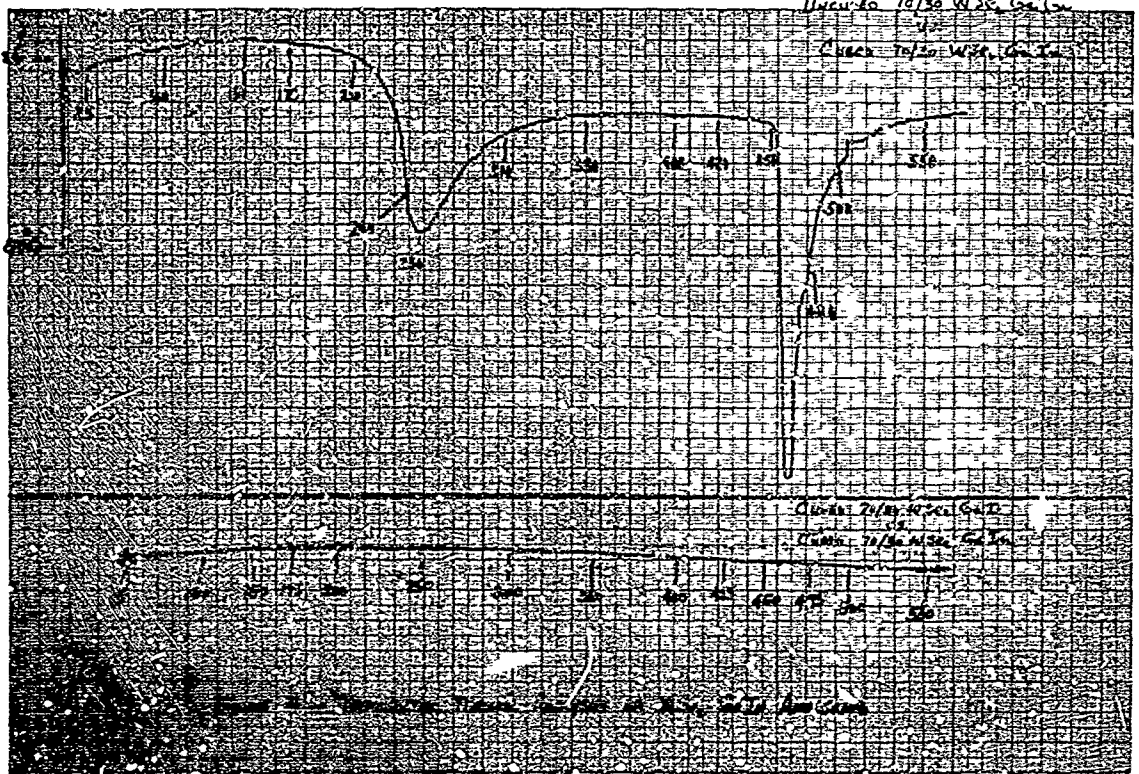



FIGURE 5

HIGH SPEED BEARING TEST LABORATORY

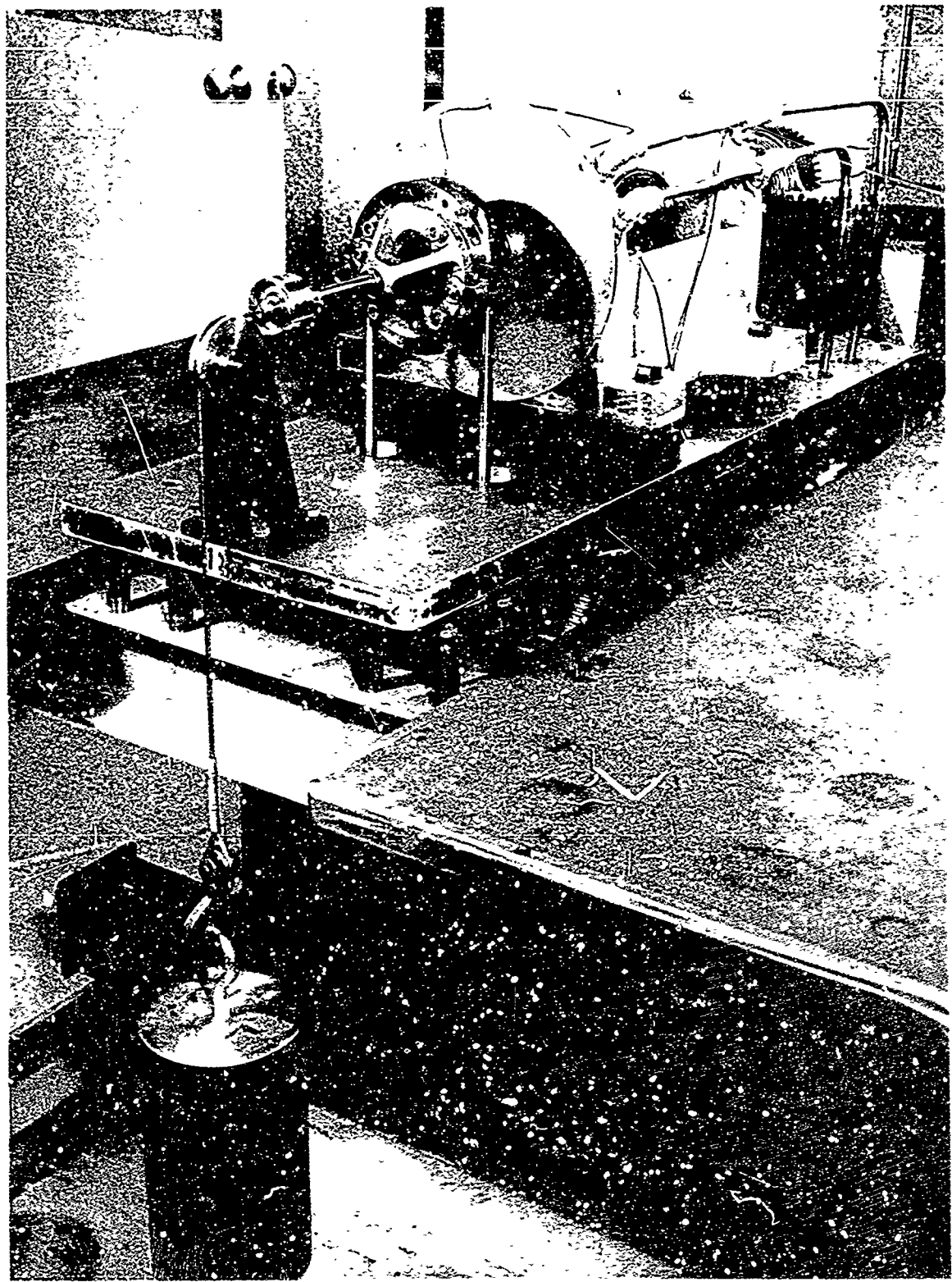

FIGURE 6

20,000 RPM TEST SPINDLE

R:4 35185

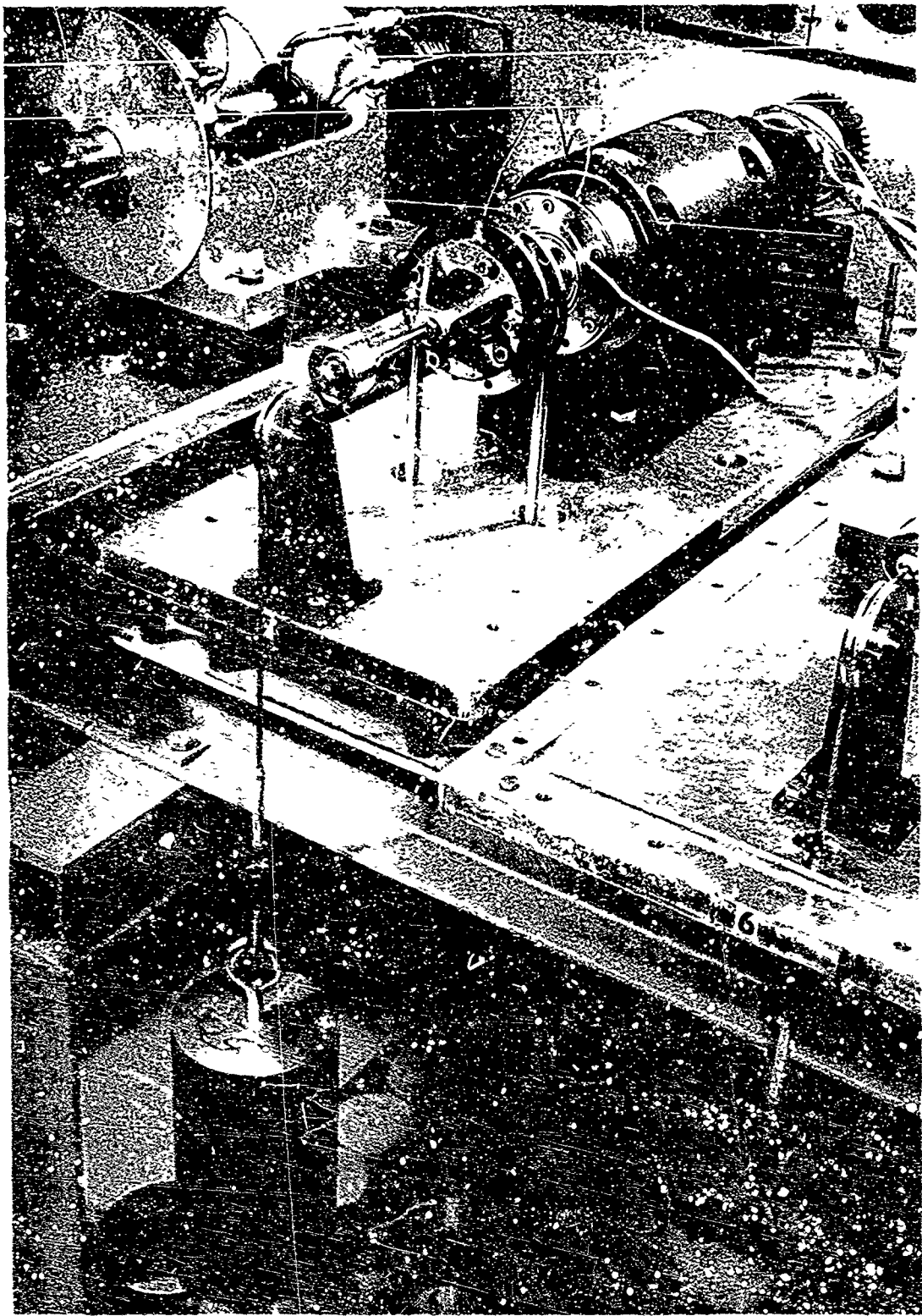

FIGURE 7
30,000 RPM TEST SPINDLE

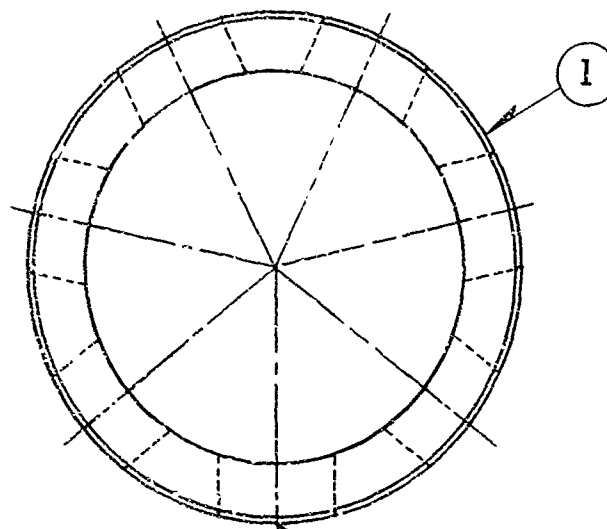

FIGURE 8

- Left Cured WSe_2 - GaIn Blank Prior to Machining
Center Machined Retainer of Tungsten Diselenide Amalgam
Right 204-M50 Ball Bearing Equipped with WSe_2 - GaIn Retainer

Dwg. 747A142

1 Composite Supplied
by Engineer



7 Holes - Equally Spaced $\frac{.353}{.352}$ Dia

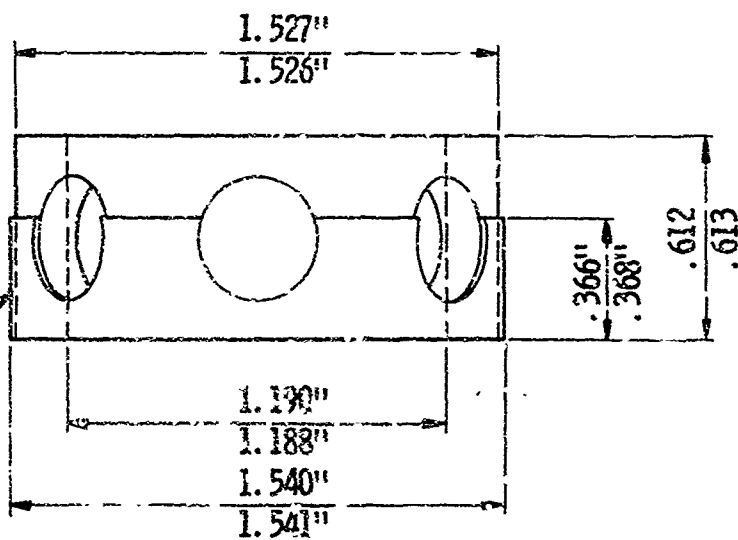

Stainless Steel
Shroud Shrunk
onto Piece with
2 mil Interference
Fit

Note: All drilling to be performed using back-up

Fig. 9-204 Retainer - outer land riding for Barden M-50 brg #M204BJHX2

