

UNCLASSIFIED

AD NUMBER

AD475152

LIMITATION CHANGES

TO:

Approved for public release; distribution is unlimited. Document partially illegible.

FROM:

Distribution authorized to U.S. Gov't. agencies and their contractors;  
Administrative/Operational Use; OCT 1965. Other requests shall be referred to Defense Advanced Research Projects Agency, TIO, 1400 Wilson Blvd, Arlington, VA 22209. Document partially illegible.

AUTHORITY

ONR ltr, 28 Jul 1977

THIS PAGE IS UNCLASSIFIED

THIS REPORT HAS BEEN DELIMITED  
AND CLEARED FOR PUBLIC RELEASE  
UNDER DOD DIRECTIVE 5200.20 AND  
NO RESTRICTIONS ARE IMPOSED UPON  
ITS USE AND DISCLOSURE.

DISTRIBUTION STATEMENT A

APPROVED FOR PUBLIC RELEASE;  
DISTRIBUTION UNLIMITED.

**BEST  
AVAILABLE COPY**

# **SECURITY**

---

# **MARKING**

**The classified or limited status of this report applies to each page, unless otherwise marked.**

**Separate page printouts MUST be marked accordingly.**

---

**THIS DOCUMENT CONTAINS INFORMATION AFFECTING THE NATIONAL DEFENSE OF THE UNITED STATES WITHIN THE MEANING OF THE ESPIONAGE LAWS, TITLE 18, U.S.C., SECTIONS 793 AND 794. THE TRANSMISSION OR THE REVELATION OF ITS CONTENTS IN ANY MANNER TO AN UNAUTHORIZED PERSON IS PROHIBITED BY LAW.**

**NOTICE: When government or other drawings, specifications or other data are used for any purpose other than in connection with a definitely related government procurement operation, the U. S. Government thereby incurs no responsibility, nor any obligation whatsoever; and the fact that the Government may have formulated, furnished, or in any way supplied the said drawings, specifications, or other data is not to be regarded by implication or otherwise as in any manner licensing the holder or any other person or corporation, or conveying any rights or permission to manufacture, use or sell any patented invention that may in any way be related thereto.**

425152

# Sweep-Frequency Backscatter with Calibrated Amplitude

by

C. R. Gilliland

October 1965

Technical Report No. 111

Prepared under

Office of Naval Research Contract

Nonr-225(64), NR 088 019, and

Advanced Research Projects Agency ARPA Order 196-65



**RADIOSCIENCE LABORATORY**

**STANFORD ELECTRONICS LABORATORIES**

**STANFORD UNIVERSITY • STANFORD, CALIFORNIA**



**DDC AVAILABILITY NOTICE**

**Qualified requesters may obtain copies of this report from DDC.  
Foreign announcement and dissemination of this report by DDC  
is not authorized.**

**SWEEP-FREQUENCY BACKSCATTER WITH CALIBRATED AMPLITUDE**

by

**C. R. Gilliland**

**October 1965**

Reproduction in whole or in part  
is permitted for any purpose of  
the United States Government.

**Technical Report No. 111**

Prepared under  
Office of Naval Research Contract  
Nonr-225(64), NR 088-019, and  
Advanced Research Projects Agency ARPA Order 196-65

**Radioscience Laboratory  
Stanford Electronics Laboratories  
Stanford University                      Stanford, California**

### ABSTRACT

The purpose of this work was the compilation of representative sets of experimental records of sweep-frequency ground backscatter--quantitative in amplitude, frequency, and group time delay. These data are intended to serve as a comprehensive source of high quality experimental data for theoretical backscatter studies currently in progress.

The invention of computer techniques for the study of ionospherically propagated ground backscatter has opened new avenues for productive research. However, efforts to exploit the computer synthesis have been hampered by the apparent lack of published, adequately-calibrated backscatter records. To gather these needed data, a special, highly instrumented and calibrated backscatter radar was assembled and operated for many months. The result is a large quantity of experimental information that should be of general use to the scientific community in the study of backscatter.

CONTENTS

	<u>Page</u>
I. INTRODUCTION . . . . .	1
II. DESCRIPTION OF THE EQUIPMENT . . . . .	2
A. Sounder . . . . .	2
B. Antenna . . . . .	6
C. Calibration Equipment . . . . .	6
III. DATA ACQUISITION . . . . .	11
A. Typical Schedule . . . . .	11
B. Operating Procedure . . . . .	12
1. Basic Adjustments . . . . .	12
2. Z-Records . . . . .	12
3. A-Records . . . . .	13
4. Calibration . . . . .	13
IV. CALIBRATION CALCULATIONS . . . . .	15
A. Transmitted Power . . . . .	15
B. Received Power . . . . .	16
V. ERROR CALCULATIONS . . . . .	20
VI. AN ATLAS OF CALIBRATED BACKSCATTER RECORDS . . . . .	26
REFERENCES . . . . .	28

TABLE

Number

1 Calibration chart for Hewlett Packard 606A rf signal generator . . . . .	23
--	----

ILLUSTRATIONS

<u>Figure</u>		<u>Page</u>
1.	System block diagram . . . . .	3
2.	The sounder . . . . .	4
3.	Scale-compression factor of the calibrated radar . . . . .	6
4.	Layout of rhombic antenna . . . . .	7
5.	Map showing antenna azimuths . . . . .	8
6.	Block diagram of range-mark generator . . . . .	10
7.	Model of calibration system . . . . .	17
8.	Example of timing chart . . . . .	26
9.	Example of original A-calibrations . . . . .	27
10.	Atlas of calibrated backscatter records . . . . .	29

## NOTATION

$E_a$	antenna voltage
$E_g$	Thévenin equivalent generator voltage
$E_m$	generator meter voltage
$E_r$	receiver terminal voltage
$E_x$	peak transmitter terminal voltage
$G_a$	antenna conductance
$P_a$	power in antenna
$P_{ind}$	indicated power
$P_{rad}$	radiated power
$P_t$	power delivered to antenna terminal
$R_a$	antenna resistance
$R_g$	generator resistance
$R_r$	receiver resistance
$X_a$	antenna reactance
$X_g$	generator reactance
$X_r$	receiver reactance
$Z_a$	antenna impedance
$Z_g$	generator impedance
$Z_r$	receiver impedance

### ACKNOWLEDGMENT

The author wishes to acknowledge his indebtedness to Dr. Thomas A. Croft, whose generous assistance gave direction and impetus to this research, to Prof. O. G. Villard, Jr., for his continued support, and to Mr. W. F. Marshall for his technical consultation. Mr. Jorge Heraud helped in the assembly and early operation of the equipment, as did Mr. James Barnum in its later operation. Mr. John Buster aided in the technical rewriting of the text and in preparing the photographic records for publication.

## I. INTRODUCTION

A high-frequency pulse radar often detects an echo commonly known as "ground backscatter." This backscatter consists of energy that has traveled outward from the transmitter, undergone one or more ionospheric refractions, scattered off the ground, and returned to the transmitting-receiving location while undergoing more ionospheric refractions. The returned energy is distributed in a complex manner with respect to time and frequency in ways that were, until recently, only vaguely understood.

The invention of computer techniques for the study of this ground-backscatter phenomenon has opened new avenues for productive research. However, efforts to exploit the computer synthesis have been hampered by a total absence of highly calibrated backscatter records quantitative with respect to amplitude, time delay, and frequency.

An hf, sweep-frequency, ionospheric backscatter radar has been designed to obtain quantitative information about the power level of the returned echo as well as the usual range and frequency data. Since this experiment was designed to accompany a study of computer synthesis of ground backscatter [Ref. 1], the system was required to provide a reasonably accurate measurement of the energy lost over the transmission path.

This backscatter system transmits 0.5- to 1.0-msec pulses of rf energy and can be automatically sweep-tuned between 7.5 and 29 Mc. By recording the echoes in range (delay time) vs amplitude (called "A-scans") and range vs frequency (called "Z-scans"), the ionospheric information is presented in a form useful for analysis. The calibrations and power levels of the A-scan records, as well as measurements of the transmitted power vs time, represent unusual procedures; thus this system differs from most backscatter sounders, which present only qualitative echo-amplitude data.

## II. DESCRIPTION OF THE EQUIPMENT

Three major sections--the sounder, antenna, and calibration equipment--comprise the backscatter radar system. Figure 1 gives a block diagram of this system; its components are described below.

### A. SOUNDER

As a unit, the sounder provides the rf power for transmission and detects the returned signal.

As shown in Fig. 2, the basic sounder consists of a modified Hammarlund SP-600 communications receiver, the ES-1A exciter, and the PA-1A power amplifier. This system (developed by Applied Technology Incorporated) is designed to sweep automatically the 7.5 - 14.8-Mc and 14.8 - 29-Mc bands of the SP-600 receiver. The following paragraphs outline the system in a step-by-step manner.

The modifications to the receiver include two buffered outputs, one of which feeds the local oscillator (LO) signal to a mixer-preamplifier in the PA-1A. Because the SP-600 is a dual-conversion superheterodyne receiver having its first intermediate frequency at 3955 kc, the LO in this receiver is tuned to track 3955 kc above the desired frequency. Only during the transmit period is this LO signal allowed to be mixed with the 3955-kc crystal oscillator in the mixer-preamplifier. The sum and difference frequencies produced are then gated back to the receiver-antenna input. Only the difference, which is the exact frequency to which the receiver is tuned, passes the tuned-rf stages. At the second rf stage, the other buffer removes the desired signal, free from spurious components, and drives the transmitter exactly in tune with the receiver.

A broadband driver in the ES-1A exciter amplifies the injected rf signal to a 50-w pulse level, which in turn drives the final power amplifier. Only the final stage of the ES-1A is tuned. A servo-tracking system in the ES-1A adjusts a Jennings vacuum-variable capacitor, which can tune this output stage over the entire 7.5 - 29-Mc range. The 1-kw peak pulse power from the ES-1A drives the PA-1A power amplifier to produce 10 - 20-kw peak output. The final output of the PA-1A is also servo-tuned but requires band-switching at 14.8 Mc.

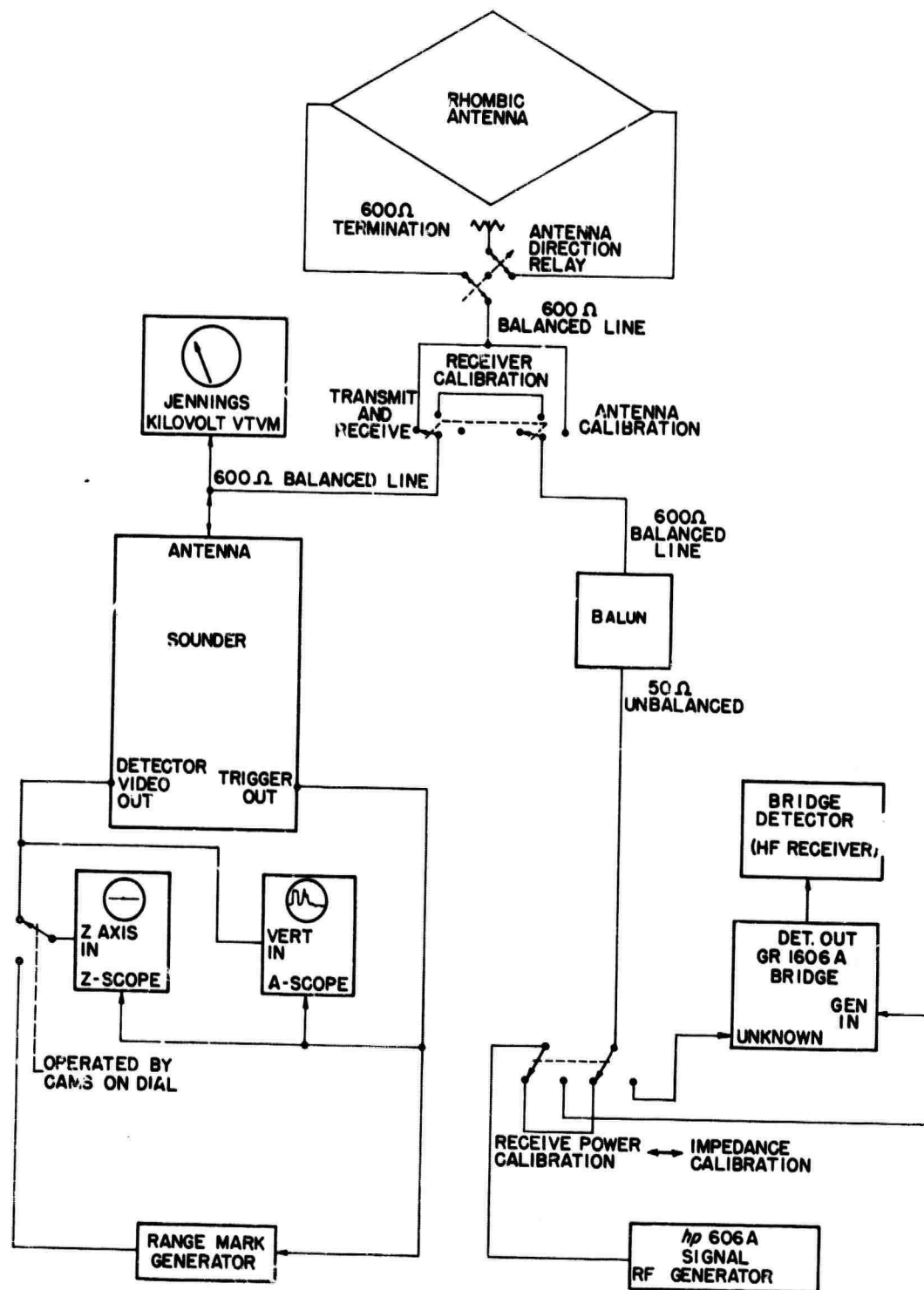

FIG. 1. SYSTEM BLOCK DIAGRAM.

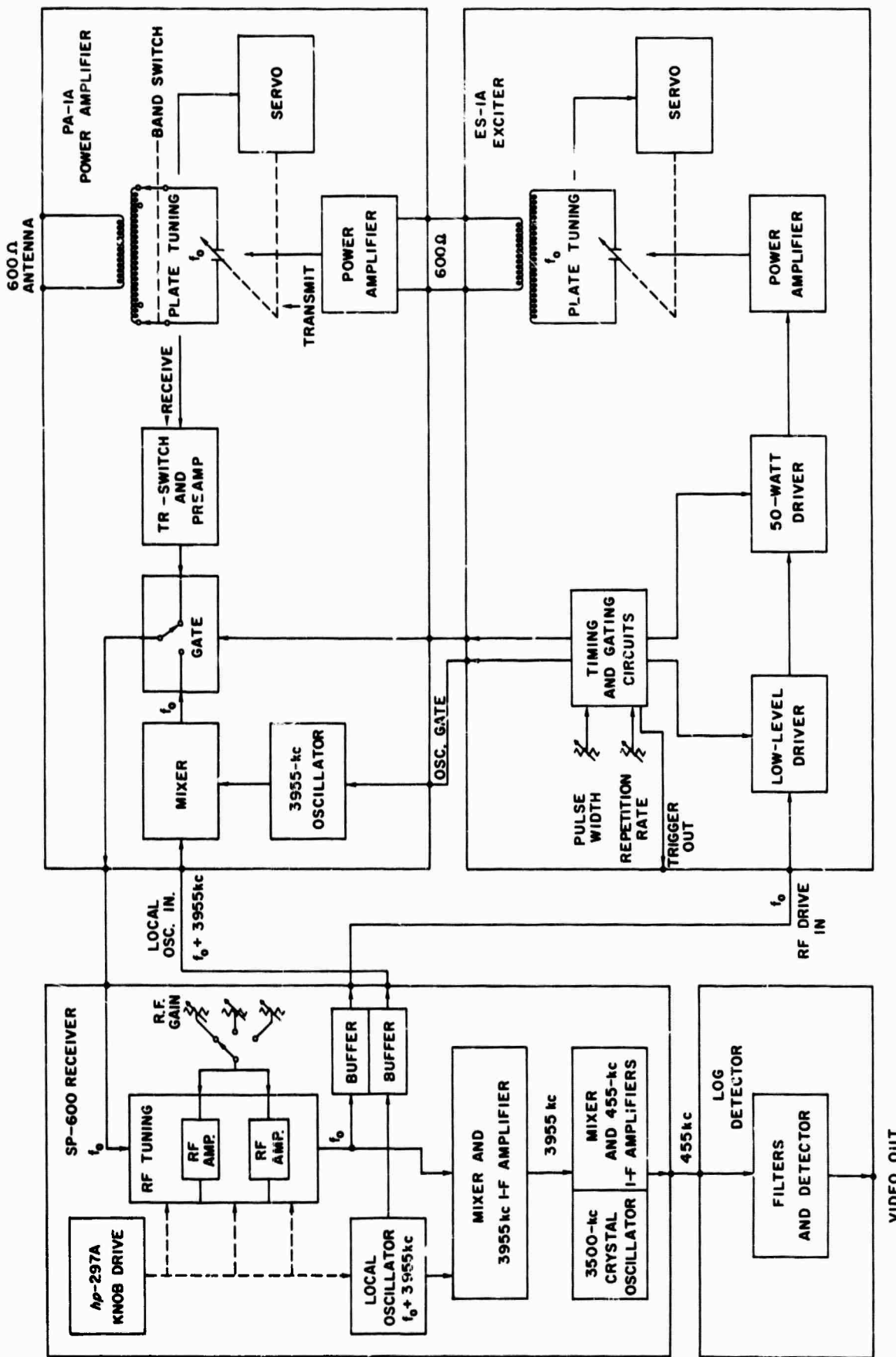

FIG. 2. THE SOUNDER.

The base of the ES-1A contains the timing and gating circuits, which may be adjusted to produce the desired pulse repetition rate and pulse width. The rf power stages in both transmitter units are controlled from this chassis. When the sounder has finished transmitting a pulse, the gate that disables the 3955-kc crystal oscillator then transfers the receiver input to the transmitting antenna through a preamplifier; thus the sounder is prepared to receive the backscattered echoes on the same antenna.

After a second conversion, to 455 kc, the receiver output is fed to a special logarithmic detector unit and is then presented to the recording oscilloscopes. This logarithmic detection allows the oscilloscopes to display a wider dynamic range of signals than would be possible in a linear system. Of the two recording oscilloscopes connected to the detector, the first presents the signal amplitude as a function of time (the A-scan) and is used both for monitoring and photographing the calibrated A-records. The second oscilloscope is a specially built unit designed for direct-coupled intensity modulation. On this oscilloscope, time (or range) is presented horizontally, while signal strength is presented as brightness. The single line generated by the oscilloscope is photographed by a slow-moving, 35-mm strip film, thus building the Z-scan pictures line by line.

The timing and gating circuits trigger the horizontal sweeps of both oscilloscopes. Ten-msec range marks are generated and are seen on the Z-records as a grid of dots whose distance from the base line shows the delay or range; their position along the base line locates the frequency scale.

The Z-records are generated by attaching a Hewlett-Packard 207A sweep-drive unit directly onto the receiver tuning shaft. The speed is such that one band is covered in 5 min, with a total of 10 min necessary for the 7.5 - 29-Mc Z-records. Except for the pause while band-switching, there are no breaks or discrete jumps in the covered frequency range.

Because the film motion and sweep drive are linear with time, the frequency scale on the Z-record follows the dial calibration. From Fig. 3 it can be discerned that the dial calibration is a close approximation to a logarithmic scale. The position of the range marks on the A-records allows this scale to be fixed along the base line.

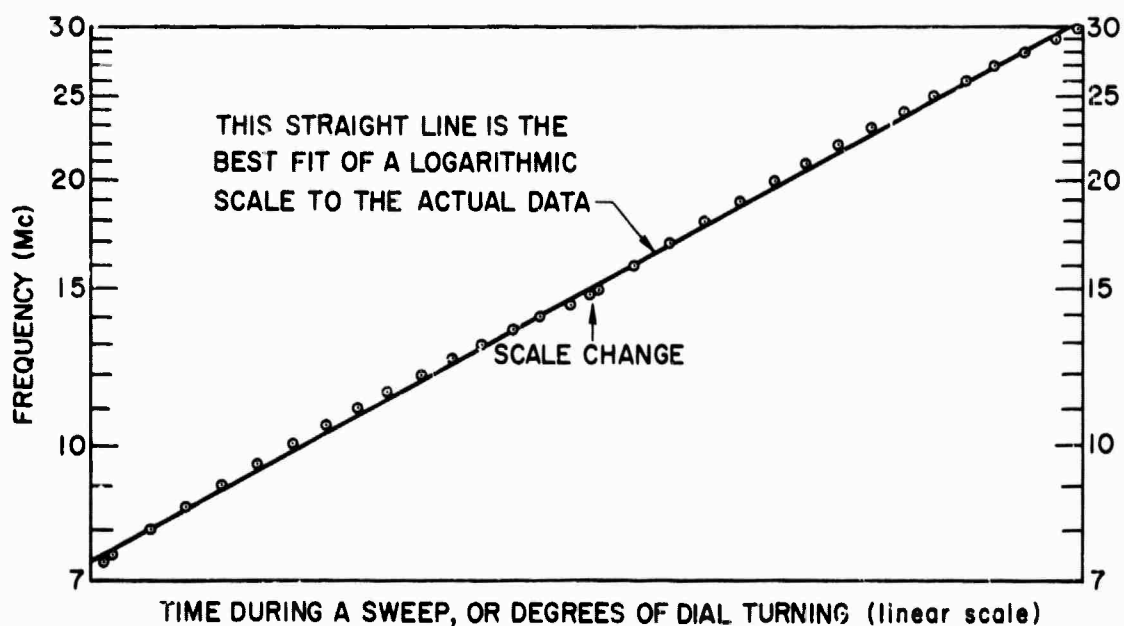

FIG. 3. SCALE-COMPRESSION FACTOR OF THE CALIBRATED RADAR.

#### B. ANTENNA

The antenna for this project was chosen because detailed pattern information was available [Ref. 2]. In addition to detailed pattern information, the basic requirements for the antenna are desirable radiation pattern and direction. The antenna selected is a rhombic (Fig. 4) located on flat marshland along the south end of San Francisco Bay, near Mountain View, California.

The antenna bearing was originally  $302^{\circ}\text{T}$ ; however, by attaching a second feed line to the NW end of the antenna, it is possible to choose either  $302^{\circ}$  or  $122^{\circ}\text{T}$  bearings (Fig. 5). A short 600-ohm transmission line connects the switching point to the equipment van.

#### C. CALIBRATION EQUIPMENT

The sounder and a calibrated time-base oscilloscope would normally be sufficient to produce the Z-records. To make the A-records with calibrated transmitted and received powers, however, the following additional equipment is required: a Jennings kilovolt vacuum-tube voltmeter (VTVM), a Hewlett-Packard 606A rf signal generator, and a General

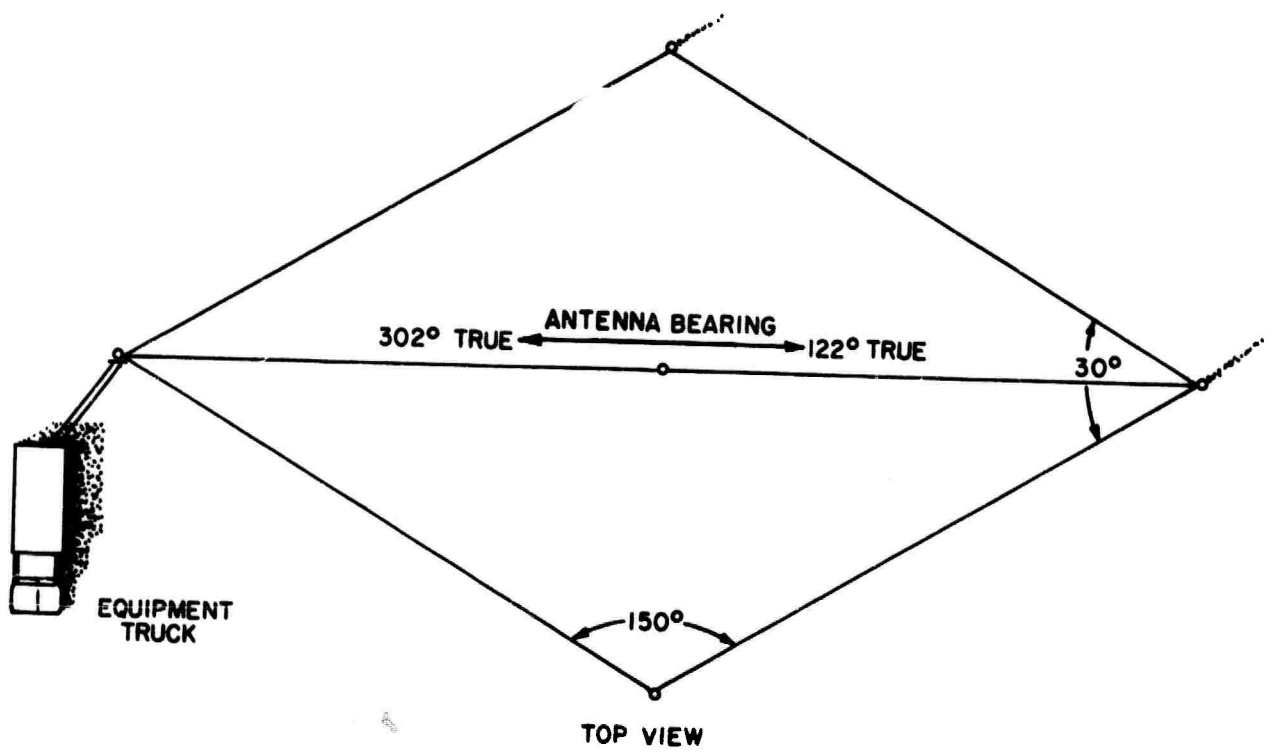
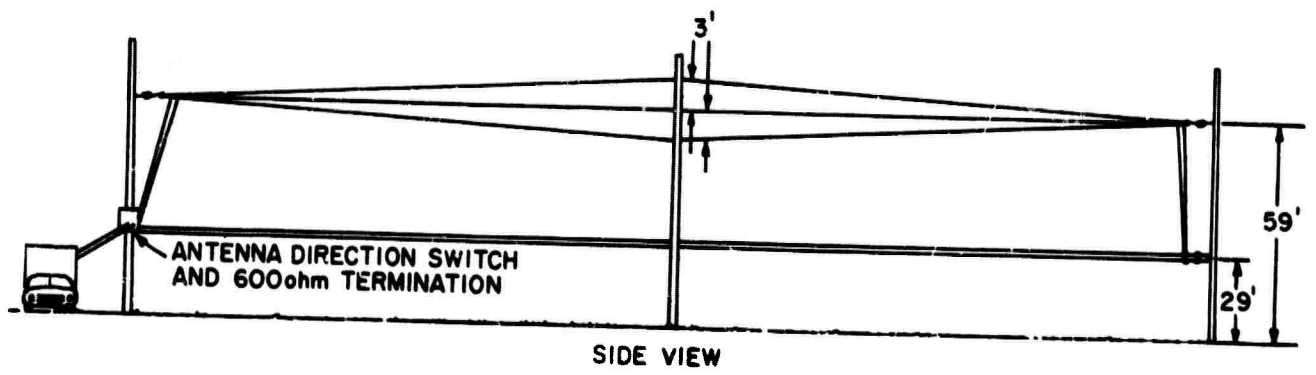

FIG. 4. LAYOUT OF RHOMBIC ANTENNA.

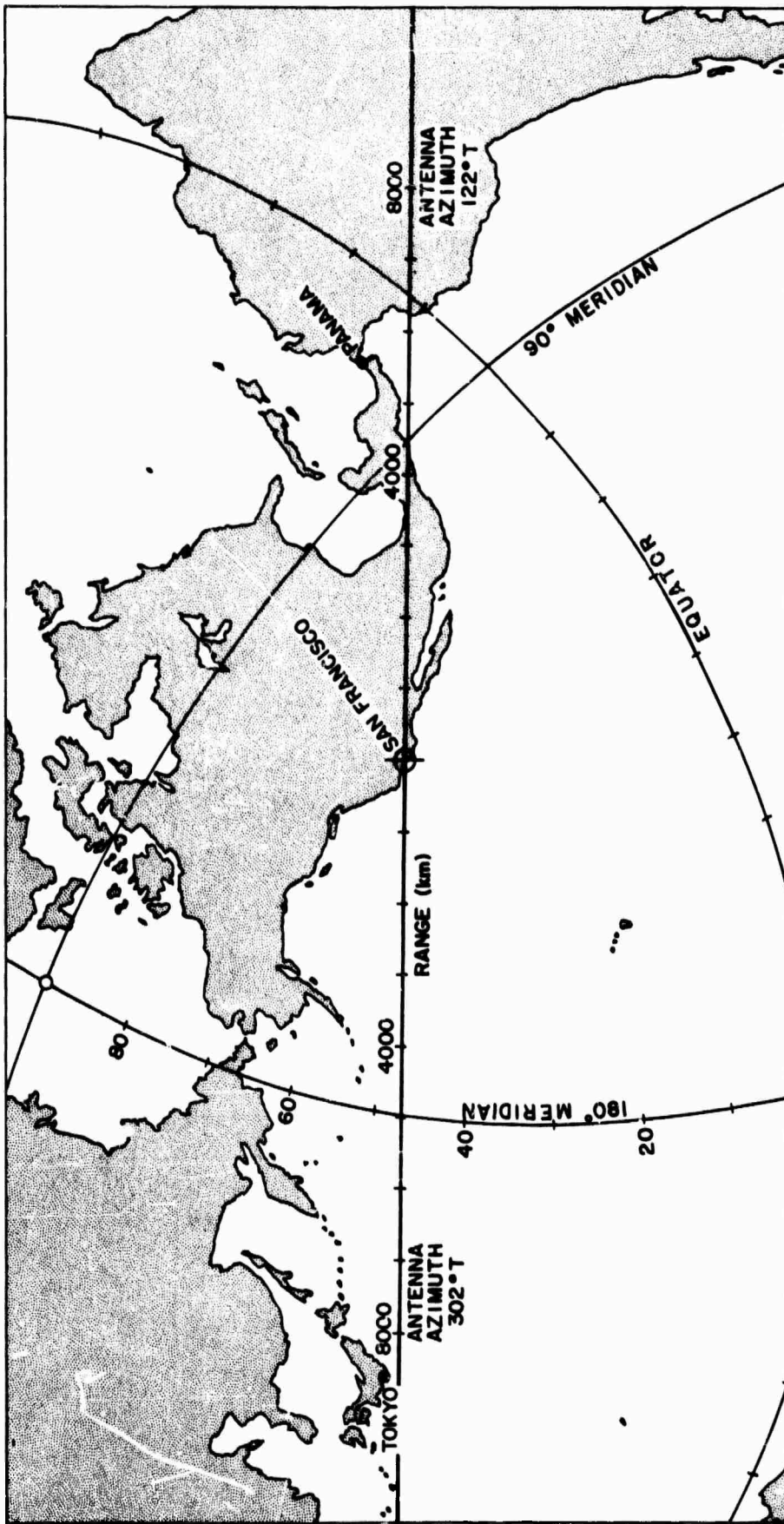

FIG. 5. MAP SHOWING ANTENNA AZIMUTHS.

Radio 1606-A rf impedance bridge. This equipment and an impedance-transforming balun can be seen in Fig. 1.

As will be shown in Chapter IV, the antenna impedance and the antenna voltage must be known in order to calculate a transmitted power. By using the antenna impedance and transmitter (effective receiver input terminal) impedance, the actual power received by the antenna can be compared with the indicated signal-generator power.

The unbalanced 50-ohm impedance of the measuring equipment is transformed by a Granger Associates Model 523-50/600 balun transformer to the balanced 600-ohm impedance at which the transmitter and antenna operate. The balun appears in the calculations only as a 12:1 impedance transformer, since tests have indicated no measurable loss.

Figure 1 shows the Jennings VTVM in position to measure the antenna terminal voltage.

Because it is not desirable to have continuous range-mark lines across the Z-records, a special range-mark generator was assembled to produce five marks spaced at 10-msec intervals beginning at the transmitted pulse. This generator produces delayed marks with accurate spacing and is triggered at the free-running pulse repetition frequency (approximately 15 pps). Pulses are gated into the Z-scope only when actuated, at three exact frequencies, by cams on the receiver dial. Thus, six sets (over two bands) of dots are unobtrusively placed on the Z-records. From these dots the frequency and delay (range) scales can be drawn along the edges of the photographs.

As shown in Fig. 6, the range-mark generator is constructed from standard Tektronix 160-series pulse units arranged in a gated regenerative loop. The trigger pulse, coincident with the transmitted rf pulse, initiates the 45-msec gate, which in turn triggers unit 2 and closes the regenerative loop. Unit 2 produces clean pulses to drive unit 3, the 10-msec delay generator. Unit 4, the final unit, produces the desired output pulse as well as a regenerating pulse. Each regenerating pulse passes through the gate, which cuts off after the fourth pulse (40 msec) has initiated the fifth pulse. The generator is now ready to accept another transmit-trigger pulse and to recycle.

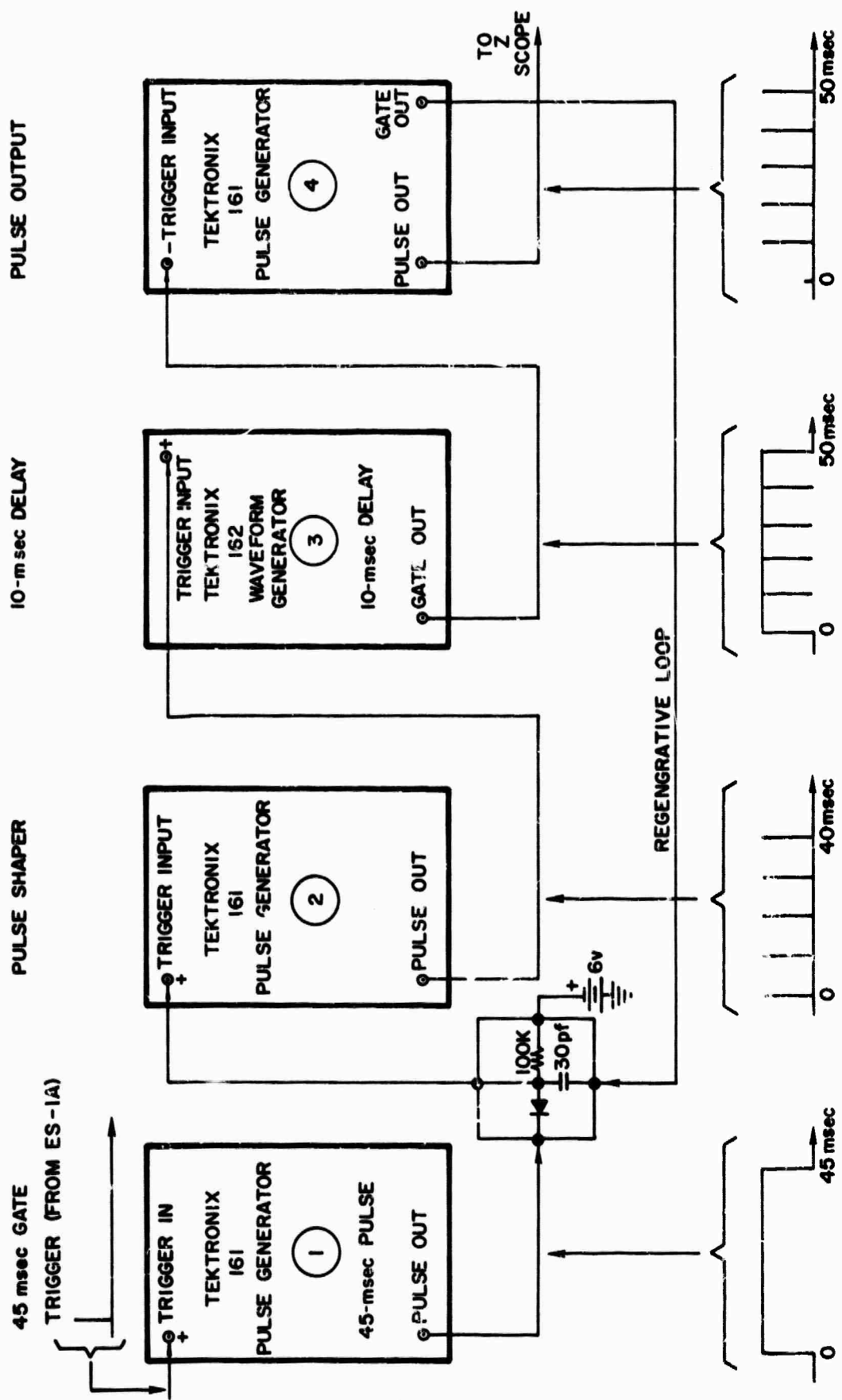

FIG. 6. BLOCK DIAGRAM OF RANGE-MARK GENERATOR.

### III. DATA ACQUISITION

The basic requirement of this system is the ability to produce sets of Z-records and calibrated A-records in the shortest practicable time. A set consists of one Z-record (7.5 - 29 Mc) and individual Polaroid A-records on every megacycle from 8 through 14 Mc on the low band of the receiver and on even megacycles from 16 through 28 Mc on the high band. In order to have the A-records represent the Z-records with the greatest accuracy, one band of A-records is taken, then the Z-record, and then the other band of A-records. The basic set is often augmented by additional Z-records taken before and after.

#### A. TYPICAL SCHEDULE

After equipment warmup, oscilloscope adjustment, and range-mark calibration, one Z-record sweep is run, starting at 29 Mc and sweeping downward in frequency to 7.5 Mc. This first sweep provides a check on equipment operation and adjustment. Sweeping downward in frequency assures better servo tracking because the atmospheric pressure assists the vacuum capacitors in this direction. Next, the A-records are taken, starting just above the highest propagating frequency. When the 16-Mc A-record is completed, the sounder is returned to 29 Mc, and the Z-sweep is started. After band-switching and completing the low band of the Z-sweep, photographing of A-records is resumed at 14 Mc. The total elapsed time is 20 - 25 min per set.

Received power calibrations are run at least once a day. For these calibrations, the rf signal generator is connected to the antenna terminal at the sounder; then, with no transmitter excitation, A-scope records are made at the standard rf power levels, which are 10 db apart throughout the useful range.

Antenna and transmitter impedances are calibrated only when changes are made in the system. Because all A-records are taken on fixed, resettable frequency points, only a finite number of points must be calibrated.

## B. OPERATING PROCEDURE

### 1. Basic Adjustments

Prior to operation but after proper warmup, several parameters are checked and adjusted. The pulse width is observed on a calibrated scope and adjusted, if necessary, to 0.5 msec. The range marks are adjusted to give five marks spaced at 10-msec intervals. A 3-kc receiver bandwidth proves adequate to receive the 0.5-msec pulses while sweeping. Since standard-size Z-records are required, the sweep range on the Z-scope is shifted so that the 0- and 50-msec marks coincide with marks on the scope face. Next, the pulse repetition rate is roughly checked to make certain that the rate is slow enough (approximately 15 pps) to allow the Z-scope time to reset and trigger on every pulse.

### 2. Z-Records

Z-records are made on a slow-moving, 35-mm film strip that photographs the horizontal scan of the Z-scope. In order to avoid differentiation, a direct-coupled amplifier is used between the receiver detector and the oscilloscope.

To start the sweep, the servos are run to the top of the band (29 Mc) by manual control and then locked to the rf drive for automatic tracking. Next, the Hewlett-Packard dial drive is switched on and the camera motor/shutter switch is simultaneously thrown. As the unit sweeps, slight manual rf gain adjustments are made. At 14.8 Mc, the end of the high band, the camera and dial drive are simultaneously switched off and the servos are locked. Then the PA-1A band-switch is thrown and its servo is retuned manually. To maintain a continuous sweep record from the high to the low band, the receiver, after band-switching, is tuned until maximum drive is shown on the PA-1A grid. The grid drive indicates that the receiver and, therefore, the rf drive are in tune with the ES-1A servo, which was locked at approximately 14.8 Mc. Thus, no gap or overlap in the frequency can occur. Before sweeping is continued, both servos are switched back to automatic tracking. Since the film shutter, film drive, and sweep drive are then turned on together, no gap appears in the photographic record. The total elapsed time at the end of the full sweep is approximately 10 min.

### 3. A-Records

The sounder is set basically the same for making A-records as for Z-records, except that the detector output feeds the A-scope. On this oscilloscope a fixed, calibrated sweep rate of 5 msec/cm and a fixed, vertical sensitivity are used. Because received-power calibrations are made after a full sequence of records, the accurate resetting of the receiver rf gain is assured by several switch-selected fixed controls that have been substituted for the usual variable control. The logging scale on the receiver dial is used for all settings, and the true frequency is measured by more accurate means at a later time.

After a frequency is selected, a Polaroid photograph is taken of the A-scope. The film is given five 1-sec exposures over a 15-sec period to integrate out the nongeneral characteristics of the backscatter. To save time, all data pertinent to this photograph (frequency, gain setting, transmitting kilovolts, and time) are dictated into a tape recorder while the Polaroid is developing. The next photograph is taken after the receiver dial has been tuned to the next fixed-frequency point, and so on until one band is completed. The last record taken is usually one frequency step beyond the highest propagating frequency.

### 4. Calibration

#### a. Received-Power Calibration

At least once each operating day, the sounder is calibrated in the receiving position on all of the A-record frequencies. This calibration consists of connecting the Hewlett-Packard 606A rf signal generator to the sounder antenna terminals and then photographing the resultant deflections of the A-scope as known power levels are switched on the signal generator. The power marked on these records is an "indicated" power and requires antenna and transmitter impedance calculations to be converted into true received power.

A calibration is made for each fixed A-record frequency used. The sounder is tuned in the same manner as for the A-records, and the servos are allowed to tune the final output. Then the servos are locked and the rf drive is disconnected. Thus, the sounder is in the receive

mode, and the signal generator can now be connected to the transmitter terminals (via the balun). The receiver gain is checked to ascertain that the setting is identical to that used on the A-records. By using the antenna terminals on the sounder, the whole receiving path to the final A-scope is calibrated at once. Care is taken to maintain conditions identical to those used when running the A-records.

These calibrations, though always run once each operating day, are found to be reasonably valid for a period of several days or more.

#### b. Impedance Calibration

The antenna and transmitter (effective receiver input) impedance measurements are taken for every A-record frequency. When changes are made in the antenna, a new set of measurements is run. Just as in the power calibration, the transmitter is tuned to the desired frequency and the servos are allowed to tune the output tank circuit. The servos are again locked and the rf drive is removed. At this time the rf signal generator (used to drive the impedance bridge) is tuned to the exact sounder frequency. The bridge detector (an R-388 communications receiver) is then tuned to the signal-generator output. This receiver, besides being used as the bridge indicator, is used to measure accurately the exact A-record frequencies.

Connected by knife-switch and jumpers, the balun is again employed to measure the impedances of the transmitter and antenna.

#### c. Miscellaneous Calibrations

The rf signal generator and Jennings kilovolt VTVM are calibrated by their respective manufacturers. The time-base of the A-scope is calibrated by a frequency standard and, from this time base, the 10-msec range-mark generator is calibrated.

#### IV. CALIBRATION CALCULATIONS

The desired values--transmitted power and received power--are not directly measurable. The direct quantitative measurements and the manner by which the desired powers are calculated from these measurements are described below.

##### A. TRANSMITTED POWER

The actual peak power radiated by the antenna is the quantity desired. This power is calculated from measurements made by the Jennings kilovolt VTVM and the antenna impedance bridge in the following manner:

The measured quantities are:

$E_x$  = peak transmitter terminal voltage (indicated by Jennings VTVM across 600-ohm transmission line)

$Z_a = R_a + jX_a$  = antenna impedance (nominal 50 ohms; measured by impedance bridge through the 12:1-impedance-ratio balun).

The parallel equivalent antenna conductance is given by

$$G_a = \frac{R_a}{R_a^2 + X_a^2} \quad (\text{nominal conductance } 1/50 \text{ ohms})$$

or, when converted to a nominal 600 ohms through the balun, by

$$G_{a600} = \frac{1}{12} \frac{R_a}{R_a^2 + X_a^2} = \frac{G_a}{12}$$

The power delivered to the antenna terminal is

$$P_t = \frac{E_x^2 G_a}{12}$$

In a terminated rhombic antenna, half of the power delivered to the terminal is radiated in the forward direction, the other half is dissipated in the 600-ohm terminating resistor (if not terminated, the antenna would be bidirectional, and half of  $P_t$  would be radiated in each direction). Therefore, the desired radiated power is

$$P_{\text{rad}} = \frac{P_t}{2} = \frac{E_a^2 G}{24} \quad (\text{peak watts}) \quad (1)$$

#### B. RECEIVED POWER

Here the calibration procedure is designed to calculate the true peak power received by the antenna from the indicated power on the A-record calibrations.

The measured quantities are:

$P_{\text{ind}}$  = indicated power given by hp 606A signal generator (nominal 50-ohm source)

$Z_a = R_a + jX_a$  = antenna impedance (nominal 50 ohms)

$Z_r = R_r + jX_r$  = transmitter (effective receiver terminal) impedance (nominal 50 ohms)

$Z_a$  and  $Z_r$  are measured by the impedance bridge through the 12:1-impedance-ratio balun.  $Z_g = R_g = 50$  ohms = hp 606A signal-generator impedance.

The deflection of the A-scope trace is a function of the voltage at the antenna terminal of the transmitter (effective receiver input).

All of these equations are derived from the model of the sounder system shown in Fig. 7. This model represents the system where  $E_g$ ,  $R_g$ , and  $X_g$  form the Thévenin equivalent of the hp 606A generator;  $E_a$ ,  $R_a$ , and  $X_a$  form the equivalent antenna, and  $R_r$  and  $X_r$  represent the effective receiver terminals. The system is in the calibration mode with the switch up and in the receive or transmit mode with the switch down. All impedances and voltages are translated to a nominal 50-ohm impedance.  $E_r$  is measured by the oscilloscope after detection by the receiver. All voltages are peak values.

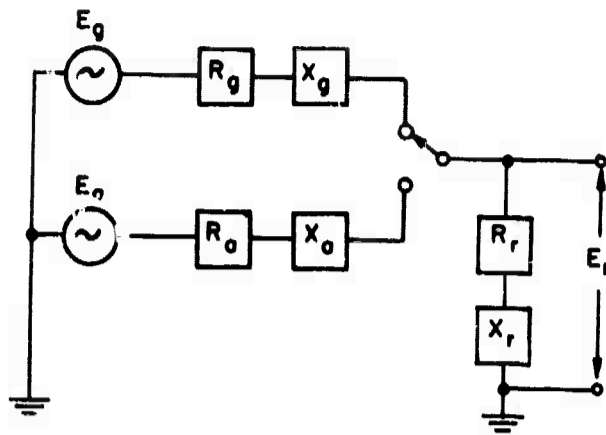

FIG. 7. MODEL OF CALIBRATION SYSTEM.

The following equations show the relationship between  $E_g$ ,  $E_a$ , and  $E_r$ . The generator has a resistance  $R_g = 50$  ohms and reactance  $X_g = 0$ , but all other impedances vary widely with frequency.

$$\frac{E_r}{E_a} = \frac{|R_r + jX_r|}{|R_a + jX_a + R_r + jX_r|}$$

$$\frac{E_r}{E_g} = \frac{|R_r + jX_r|}{|50 + R_r + jX_r|}$$

$$E_r = \frac{E_a |R_r + jX_r|}{|R_a + jX_a + R_r + jX_r|} = E_g \frac{|R_r + jX_r|}{|50 + R_r + jX_r|}$$

Thus, for a given deflection on the A-scope (proportional to  $E_r$ )

$$E_a = E_g \frac{R_a + jX_a + R_r + jX_r}{50 + R_r + jX_r} \quad (2)$$

The total power delivered to the antenna is assumed equal to the total power produced by the Thévenin-equivalent voltage generator  $E_a$ . Thus, the power delivered to the antenna is

$$P_a = \frac{E_a^2 (R_a + R_r)}{(R_a + R_r)^2 + (X_a + X_r)^2}$$

and is dissipated in both  $R_a$  and  $R_r$ .

Substituting Eq. (2) for  $E_a$ , we can relate the power  $P_a$  to  $E_g$  by

$$P_a = \frac{E_g^2 (R_a + R_r)}{(50 + R_r)^2 + X_r^2}$$

$E_g$  is the voltage of the equivalent internal voltage generator and not the indicated voltage  $E_m$  shown on the hp 606A signal-generator meter. It is equal to twice the peak terminal voltage; thus  $E_g = 2\sqrt{2} E_m$ , where  $E_m$  is the voltage shown on the meter.

The power indicated by the meter is  $P_{ind} = E_m^2 / 50$ . Because  $E_m = E_g / 2\sqrt{2}$

$$P_{ind} = \frac{E_g^2}{(2\sqrt{2})^2 \times 50} = \frac{E_g^2}{400}$$

The ratio of the power in the antenna  $P_a$  to the indicated power  $P_{ind}$  is

$$\frac{P_a}{P_{ind}} = \frac{E_g^2 (R_a + R_r)}{(50 + R_r)^2 + X_r^2} \left[ \frac{E_g^2}{400} \right]^{-1} = \frac{400(R_a + R_r)}{(50 + R_r)^2 + X_r^2} \quad (3)$$

The above equation in its final form is the correction factor applied to the A-record calibrations. In decibels this ratio becomes

$$\frac{P_a}{P_{ind}} \text{ (db)} = (10 \log_{10} 400) + \left[ 10 \log_{10} \frac{R_a + R_r}{(50+R_r)^2 + X_r^2} \right]$$

For the ideal 50-ohm antenna and 50-ohm receiver, this correction reduces to

$$\begin{aligned} \frac{P_a}{P_{ind}} &= (10 \log_{10} 400) + \left[ 10 \log_{10} \frac{50 + 50}{(50+50)^2} \right] \\ &= (10 \log_{10} 400) - (10 \log_{10} 100) \\ &= 10(2.60206-2.0000) = 6 \text{ db} . \end{aligned}$$

In practice, this correction has varied +3 db to -7 db from the ideal 6 db.

## V. ERROR CALCULATIONS

Section IV presented calculations for the transmitted and received power separately because the received-data presentation is independent of the transmitted power. After making the power corrections, the A-record powers are combined with the transmitted powers to give the transmitted-to-received power ratios. The following calculations directly show this relationship and then examine each factor and the error it contributes.

The ratio between the transmitted and received powers is derived by taking Eq. (3) and rewriting it in terms of the received power as

$$P_a = 400 P_{ind} \frac{R_a + R_r}{(50+R_r)^2 + X_r^2}$$

and dividing it by Eq. (1) for the transmitted power

$$P_{rad} = \frac{E_t^2 G_a}{24} = \frac{E_t^2}{2} \frac{R_a}{R_a^2 + X_a^2} \frac{1}{12},$$

which gives

$$\begin{aligned} \frac{P_a}{P_{rad}} &= P_{ind} \frac{400 \times 2 \times 12 (R_a + R_r) (R_a^2 + X_a^2)}{E_t^2 [(50+R_r)^2 + X_r^2] R_a} \\ &= \frac{P_{ind}}{E_t^2} \frac{(R_a + R_r) (R_a^2 + X_a^2)}{[(50+R_r)^2 + X_r^2] R_a} (9.6 \times 10^3). \end{aligned} \quad (4)$$

There are six independent variables:  $P_{ind}$ ,  $E_t$ ,  $R_a$ ,  $X_a$ ,  $R_r$ , and  $X_r$ .

For error calculations Eq. (4) is defined as  $\rho$  and is broken into three sections as follows:

$$\rho = \left[ \frac{(R_a + R_r)(R_a^2 + X_a^2)}{[(50 + R_r)^2 + X_r^2]R_a} \right] [P_{ind}] \left[ \frac{1}{E_t^2} \right] (9.6 \times 10^3) .$$

For convenience, the first section is designated as  $\xi$  and the equation is rewritten as

$$\rho = [\xi] [P_{ind}] \left[ \frac{1}{E_t^2} \right] (9.6 \times 10^3)$$

with each of the three terms to be analyzed separately for its contribution to the error in  $\rho$ .

The four variables  $R_a$ ,  $X_a$ ,  $R_r$ , and  $X_r$ , which are considered independent variables although they are measured by the same impedance bridge, comprise  $\xi$ . Large variations in the servo-tuning of the transmitter tank circuit causes variations so large in  $R_r$  and  $X_r$  as to be independent of any systematic errors in the bridge. If

$$\xi = \frac{R_a^2 + X_a^2}{R_a} \frac{R_a + R_r}{(50 + R_r)^2 + X_r^2} ,$$

it can be shown [Ref. 3] that the standard deviation in  $\xi$ ,  $s\xi$ , is the following function of  $sR_a$ ,  $sX_a$ ,  $sR_r$ , and  $sX_r$ ,

$$s\xi = \left[ \left( \frac{\partial \xi}{\partial R_a} \right)^2 (sR_a)^2 + \left( \frac{\partial \xi}{\partial X_a} \right)^2 (sX_a)^2 + \left( \frac{\partial \xi}{\partial R_r} \right)^2 (sR_r)^2 + \left( \frac{\partial \xi}{\partial X_r} \right)^2 (sX_r)^2 \right]^{1/2} ,$$

where  $sR_a$  is the standard deviation from the mean of  $R_a$ , etc. These partial derivatives are:

$$\frac{\partial \xi}{\partial R_a} = \frac{R_a (R_a^2 + X_a^2) + (R_a + R_r)(R_a^2 - X_a^2)}{[(50 + R_r)^2 + X_r^2] R_a^2}$$

$$\frac{\partial \xi}{\partial X_a} = \frac{(R_a + R_r) 2X_a}{[(50 + R_r)^2 + X_r^2] R_a}$$

$$\frac{\partial \xi}{\partial R_r} = \frac{R_a^2 + X_a^2 [(50 + R_r)^2 + X_r^2] - 2(R_a + R_r)(50 + R_r)}{R_a [(50 + R_r)^2 + X_r^2]^2}$$

$$\frac{\partial \xi}{\partial X_r} = - \frac{R_a^2 + X_a^2}{R_a} \frac{(R_a + R_r) 2X_r}{[(50 + R_r)^2 + X_r^2]^2}$$

Because the four parameters of  $\xi$  have no relationship with respect to each other for the fixed-frequency points (i.e., on one frequency  $R_a$  is 46.9 ohms and  $R_r$  is 37 ohms while on another frequency  $R_a$  is 29 ohms and  $R_r$  is 7 ohms) no general conclusions can be made about the relative importance of any one of the partial derivatives above.

The parameters with the widest variations are  $R_r$  and  $X_r$ . These are quite critical to the servo-tuning, and it was found that the servo was not resetting as close as anticipated. A more precise method of tuning this circuit has been developed and will be used in future operations. Unfortunately, not enough impedance measurements were made on the early runs to derive any statistics on variations in the servo-tuning. The following error calculations pertaining to  $\xi$  are based on a series of tests run later. For these tests the transmitter (receiver input) impedance is measured for each servo resetting on a given frequency (six frequencies and two antenna settings each). The receiver (as well as the

tank circuit) is detuned before making another measurement, and several days are allowed to elapse between sets of measurements. These data are indications of the general conditions existing when the backscatter data were taken. Because of the small number of samples the data fell into a split distribution: one group about 0 - 10-percent standard deviation, and an equal group about 30 - 55-percent standard deviation. Thus, the worst case, 50 percent, had to be chosen as the error due to  $\xi$ . In the improved tuning system this error has been reduced to approximately 10 percent.

The next component of  $\rho$  to be discussed is  $P_{ind}$ , the power indicated by the Hewlett-Packard 606A rf signal generator. The manufacturer's literature gives an inclusive accuracy of 1 db, which is a 1:1.25 power ratio ( $\approx 25$  percent). Although the instrument used had been recalibrated by the manufacturer while the experiment was in progress, the

Table 1. Calibration Chart for Hewlett Packard 606A rf signal generator.

FREQUENCY (Mc)	INDICATED POWER (dbm)	ACTUAL OUTPUT (dbm)	
		Before Adjustment	After Adjustment
7	-21.0	-21.4	-21.1
8	-21.0	-21.4	-21.0
9	-21.0	-21.35	-21.0
10	-21.0	-21.2	-21.0
12	-21.0	-21.15	-20.9
14	-21.0	-21.1	-20.8
16	-21.0	-21.1	-20.9
18	-21.0	-21.1	-20.7
20	-21.0	-21.4	-21.0
22	-21.0	-21.4	-21.0
24	-21.0	-21.35	-21.0
26	-21.0	-21.3	-21.1
28	-21.0	-21.2	-20.95
29	-21.0	-21.2	-21.0

power output deviated from the meter indication on the average about  $\pm 0.3$  db before and after calibration.

For the range concerned here, 7 - 30 Mc, the manufacturer stated to the author that this  $\pm 0.3$  db, equivalent to approximately  $\pm 7.5$  percent, was a valid choice for instrument error.

The last measured component of  $\rho$  is  $E_t$ , the peak voltage across the antenna terminals as measured by the Jennings VTVM. As in the case of the rf signal generator, this instrument can be relied on with a greater accuracy than stated in the manufacturer's general specifications. On the scale used for all voltage measurements (5 kv full scale), the readings centered about 2.5 kv. The specified accuracy of  $\pm 3$  percent of the 5-kv full scale would allow for an error of  $\pm 150$  v, or about 6 percent in these readings. Calibration data for the instrument, calibrated by Jennings, are available both before and after adjustment. Before adjustment, the readings at full-scale and mid-scale were 2 and 4 percent high, respectively. After calibration the meter readings showed insignificant error.

Another potential source of systematic error in  $E_t$  is the effect of the pulse repetition rate on the meter-circuit time constant. The Jennings instruction manual gives correction information for various dc pulse-duty cycles. Because the pulses in this experiment are rf envelopes, however, the meter indicates the true peak reading with no sag between pulses; this finding was confirmed by an oscilloscope. Therefore 3-percent accuracy with respect to the above calibrations, checks, and aging is chosen as a reasonable error for this instrument.

The total percentage error in  $\rho$  is calculated by the rms combination of the fractional errors in  $P_{ind}$ ,  $E_t$ , and  $\xi$ . Partial derivative analysis gives the same results as rms combination of the fractional error, but, because of the simple relationship between  $P_{ind}$ ,  $E_t$ , and  $\xi$ , the rms combination has proved the most practical method in this case. If the fractional error in  $P_{ind}$  and  $E_t$ , drawn from the manufacturers' data, are taken to be fractional standard deviations of the parameters in question, it is valid to combine the fractional deviation of  $\xi$  with the above two values. Thus

$$\begin{aligned} \frac{s_D}{\rho} &= \left[ \left( \frac{s_f}{f} \right)^2 + \left( \frac{s_{P_{ind}}}{P_{ind}} \right)^2 + \left( \frac{2s_{E_t}}{E_t} \right)^2 \right]^{1/2} \\ &= [(0.50)^2 + (0.075)^2 + (2 \times 0.03)^2]^{1/2} \\ &= [0.25 + 0.0056 + 0.0036]^{1/2} = [0.259]^{1/2} = 0.51 \text{ or } 51 \text{ percent.} \end{aligned}$$

Since the major source of error comes from the impedance measurements, the smaller errors in the kilovolt VTVM and rf signal generator can almost be neglected. With the improved tuning system, the impedance deviations are reduced to a point where the three error factors are of nearly equal weight. Thus, the accuracies of the rf signal generator and kilovolt VTVM will hold a more important role in future operations.

## VI. AN ATLAS OF CALIBRATED BACKSCATTER RECORDS

This chapter contains 90 Z-records and 25 sets of calibrated A-records. Most, though not all, of the Z-records are matched with calibrated A-records; especially interesting is the long sequence of Z-records of 7 November 1964. All records are presented in chronological order and grouped into sets of A- and Z-records.

At the beginning of each set of calibrated records, a timing chart (Fig. 8) has been placed. These allow the reader to ascertain at a quick glance the number and timing of records in the set.

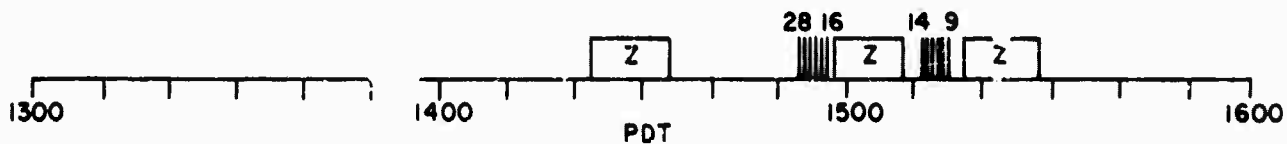

FIG. 8. EXAMPLE OF TIMING CHART.

The Z-records are represented by the boxes marked Z covering the 10-min interval in which the record was made. Small vertical lines between the Z-records show the timing of the A-records, with the first and last records in a group marked with their frequencies in megacycles. Where no A-records were made, no timing charts are given for that day.

The calibrations around the borders of the Z-records are self-explanatory. It should be noted that the time, recorded along the top, increases from right to left. Since the transmit-receive gate is about 5 msec long, the zero has been allowed to fall somewhat below the lower edge of the Z-record. Zero may be found by extrapolating the range scales.

Figure 9 shows A-records and original A-calibrations. The horizontal traces on the calibration records represent the indicated power levels introduced by the generator. The calibrations along the right-hand edge are corrected received-power levels, which are labeled as

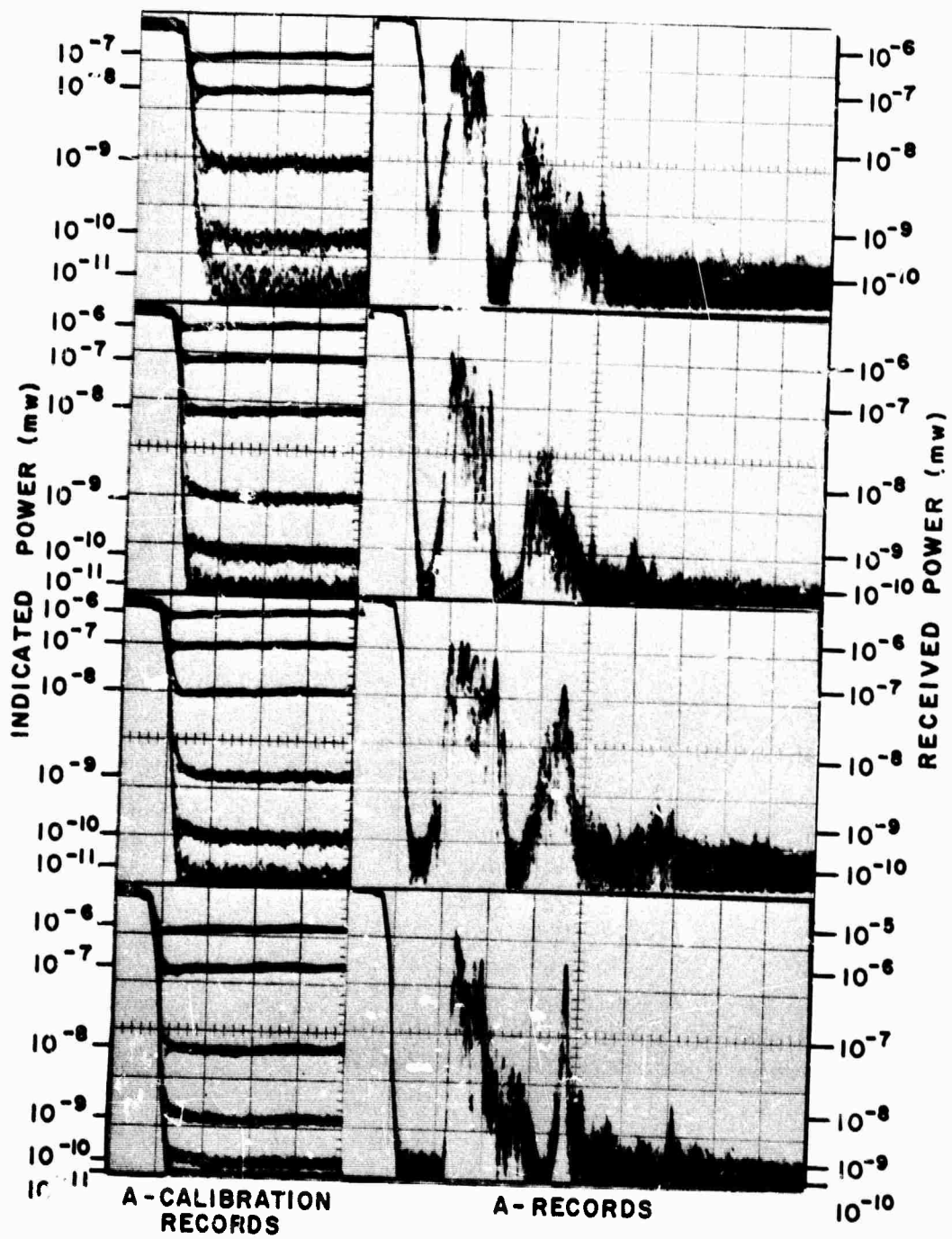

FIG. 9. EXAMPLE OF ORIGINAL A-CALIBRATIONS.

received power on the A-record pages. The frequency, time, and corrected transmitted power are indicated beside all records except the calibration example in Fig. 9, from which they have been omitted for purpose of clarity.

The compilation of calibrated backscatter records is presented in Fig. 10.

#### REFERENCES

1. T. A. Croft, "The Synthesis of Sweep-Frequency Ground Backscatter by Digital Computer," Rept. SU-SEL-65-002 (TR No. 84), Stanford Electronics Laboratories, Stanford, Calif., Jan 1965.
2. Cecil Barnes, "Antenna Pattern Measurement of a Full-Scale Rhombic Antenna," Supplement 2 to Research Memorandum No. 9, Contract DA36-039 SC-87 197, SRI Project No. 3670, Stanford Research Institute, Menlo Park, Calif., May 1963.
3. Yardley Beers, Theory of Error, Addison-Wesley Publishing Co., Inc., Reading, Mass., 1953, pp. 26-36.

FIG. 10. ATLAS OF CALIBRATED BACKSCATTER RECORDS.

Page	Record	Date	Bearing (deg)	Page	Record	Date	Bearing (deg)
30	Z	27 Oct 1964	302	79	A	10 Mar 1965	302
31	Z	27 Oct 1964	302	80	Z	11 Mar 1965	302
32	A	27 Oct 1964	302	81	Z	11 Mar 1965	302
33	A	27 Oct 1964	302	82	A	11 Mar 1965	302
34	Z	3 Nov 1964	302	83	A	11 Mar 1965	302
35	A	3 Nov 1964	302	84	A	11 Mar 1965	302
36	A	3 Nov 1964	302	85	A	11 Mar 1965	302
37	Z	7 Nov 1964	302	86	Z	12 Mar 1965	302
38-49	Z	7 Nov 1964	302	87	Z	16 Mar 1965	302
50	Z	7 Nov 1964	302	88	Z	16 Mar 1965	302
51	Z	16 Feb 1965	122	89	A	16 Mar 1965	302
52†	Z	16 Feb 1965	122	90	A	16 Mar 1965	302
52‡	Z	17 Feb 1965	122	91	Z	18 Mar 1965	302
53	Z	18 Feb 1965	122	92	Z	22 Mar 1965	302
54	Z	18 Feb 1965	122	93	Z	22 Mar 1965	302
55	Z	23 Feb 1965	122	94	A	22 Mar 1965	302
56	A	23 Feb 1965	122	95-97	A	22 Mar 1965	302
57	A	23 Feb 1965	122	98	Z	23 Mar 1965	302
58	Z	23 Feb 1965	122	99	Z	23 Mar 1965	302
59	A	23 Feb 1965	122	100-103	A	23 Mar 1965	302
60	A	23 Feb 1965	122	104	Z	23 Mar 1965	302
61	Z	24 Feb 1965	122	105-106	A	23 Mar 1965	302
62	Z	8 Mar 1965	302	107	Z	12 Apr 1965	122
63	Z	8 Mar 1965	302	108-109	A	12 Apr 1965	122
64	A	8 Mar 1965	302	110	Z	14 Apr 1965	122
65	A	8 Mar 1965	302	111	Z	14 Apr 1965	122
66	A	8 Mar 1965	302	112-113	A	14 Apr 1965	122
67	Z	9 Mar 1965	302	114	Z	14 Apr 1965	122
68	A	9 Mar 1965	302	115-116	A	14 Apr 1965	122
69	A	9 Mar 1965	302	117	Z	22 Apr 1965	122
70	Z	9 Mar 1965	302	118-119	A	22 Apr 1965	122
71	Z	9 Mar 1965	302	120	Z	26 Apr 1965	302
72	A	9 Mar 1965	302	121	Z	27 Apr 1965	122
73	A	9 Mar 1965	302	122	Z	27 Apr 1965	122
74	A	9 Mar 1965	302	123-124	A	27 Apr 1965	122
75	A	9 Mar 1965	302	125	Z	28 Apr 1965	122
76	Z	10 Mar 1965	302	126	Z	28 Apr 1965	122
77	Z	10 Mar 1965	302	127-128	A	28 Apr 1965	122
78	A	10 Mar 1965	302				

† Top

‡ Bottom

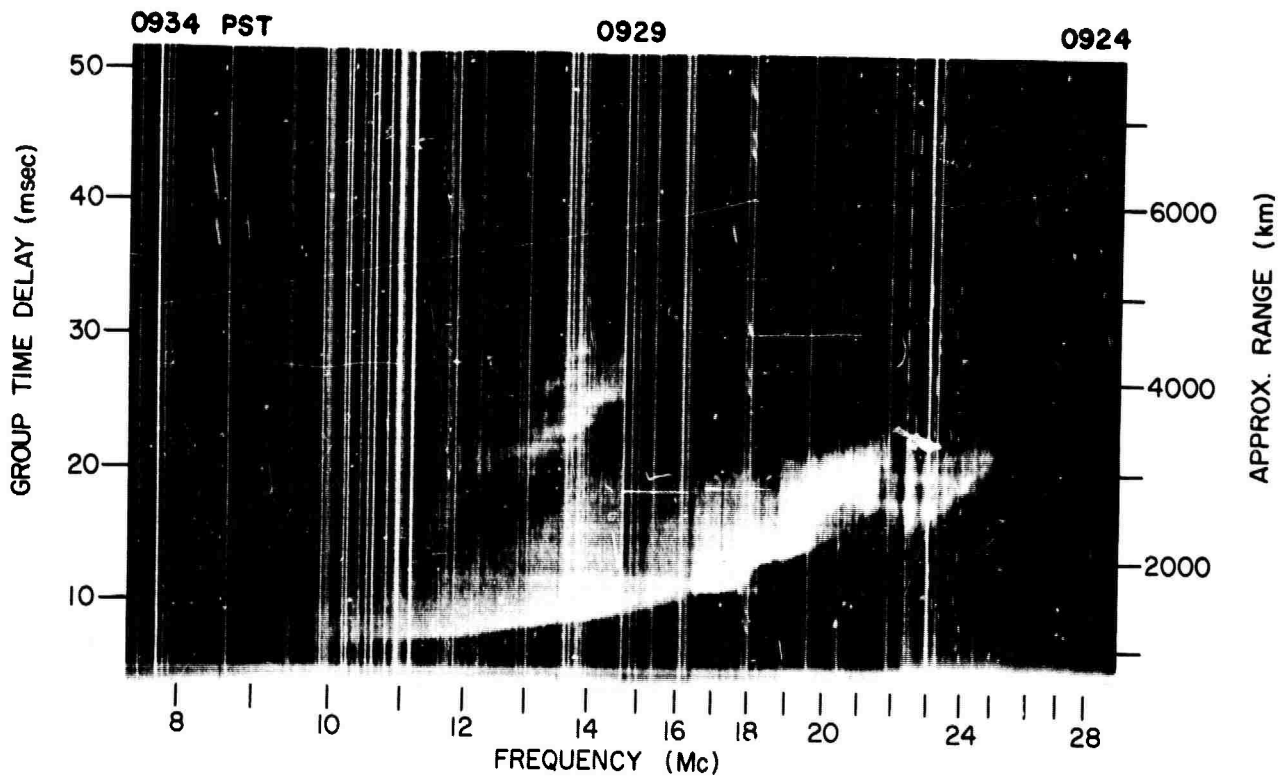
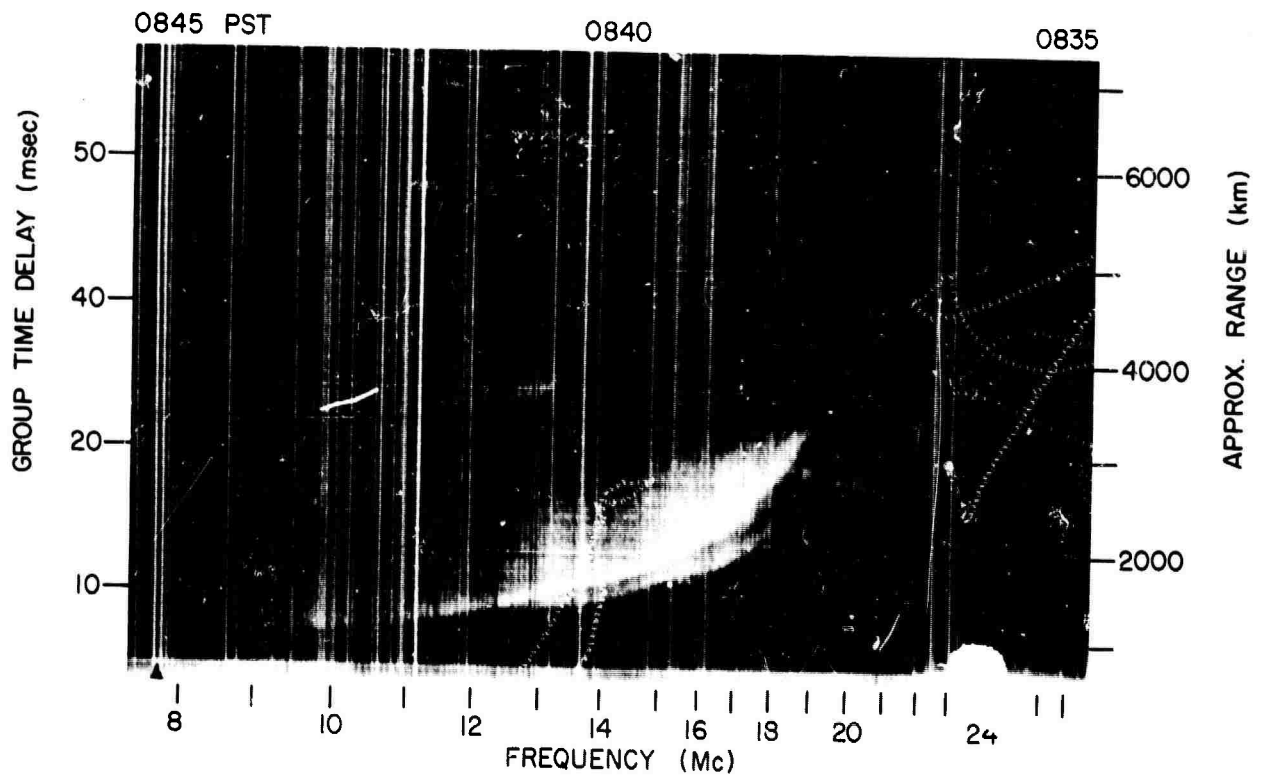
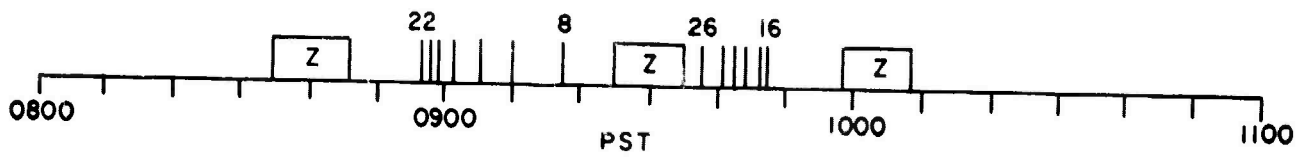

Z RECORDS, 27 OCT 1964, 302° BEARING

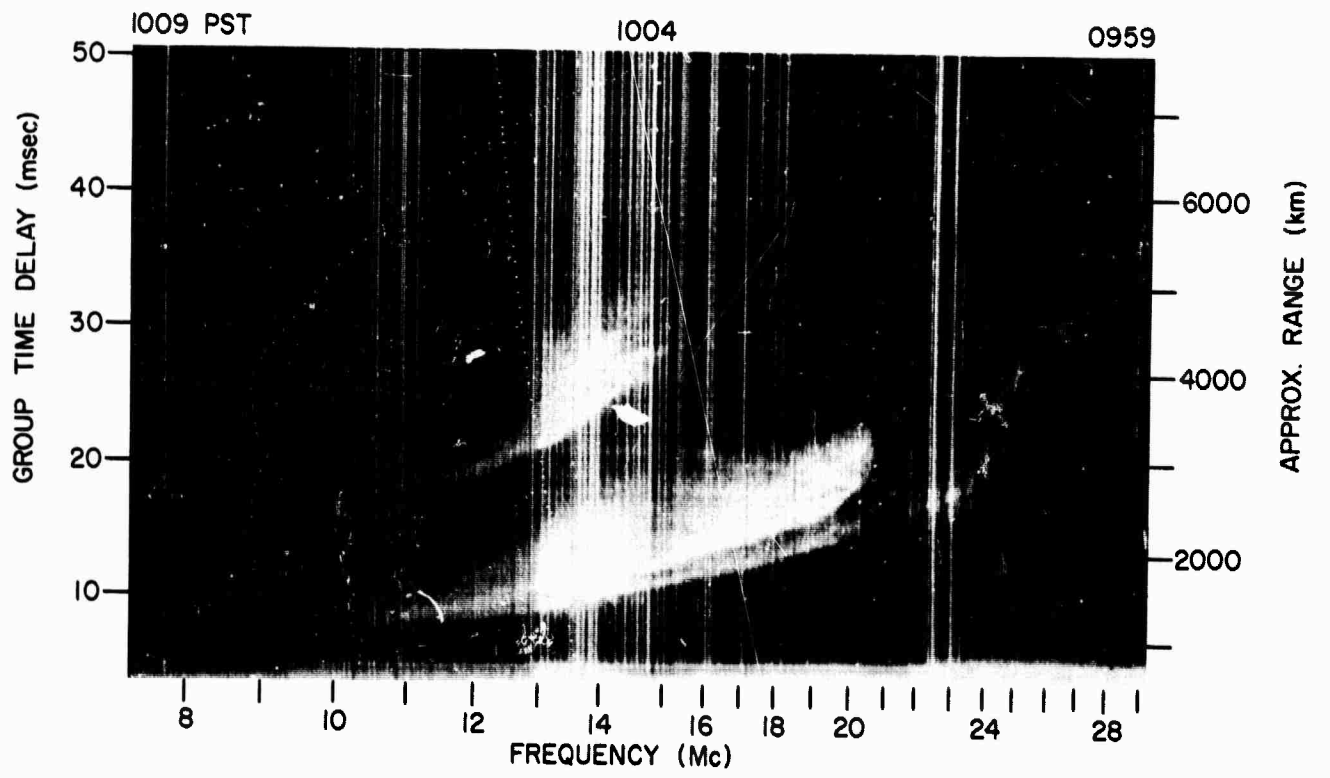

Z RECORD, 27 OCT 1964, 302° BEARING

FREQ.  
TIME  
XMTD. POWER

FREQ.  
TIME  
XMTD. POWER

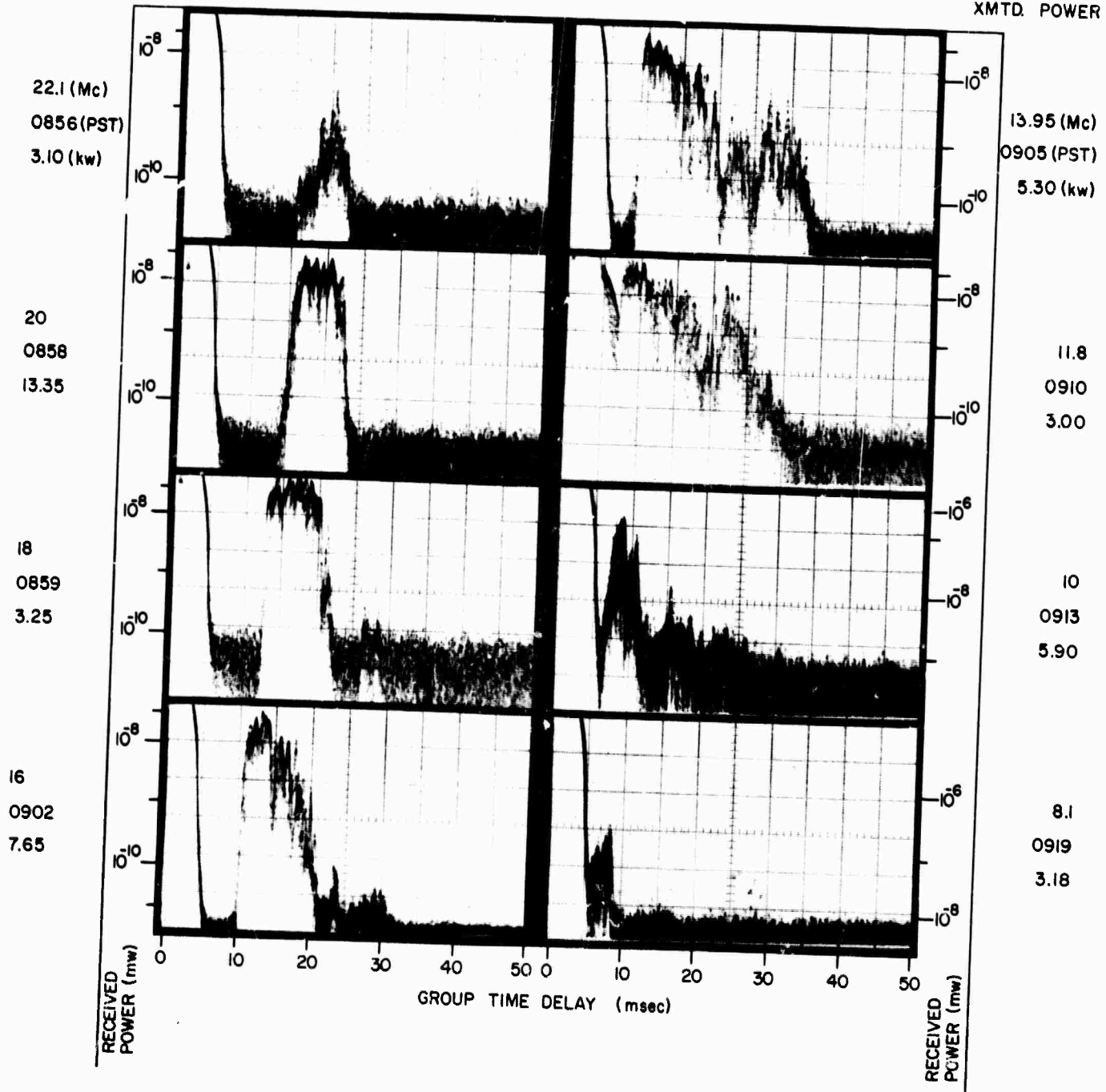

A RECORDS, 27 OCT 1964, 302° BEARING

FREQ.  
TIME  
XMTD. POWER

FREQ.  
TIME  
XMTD. POWER

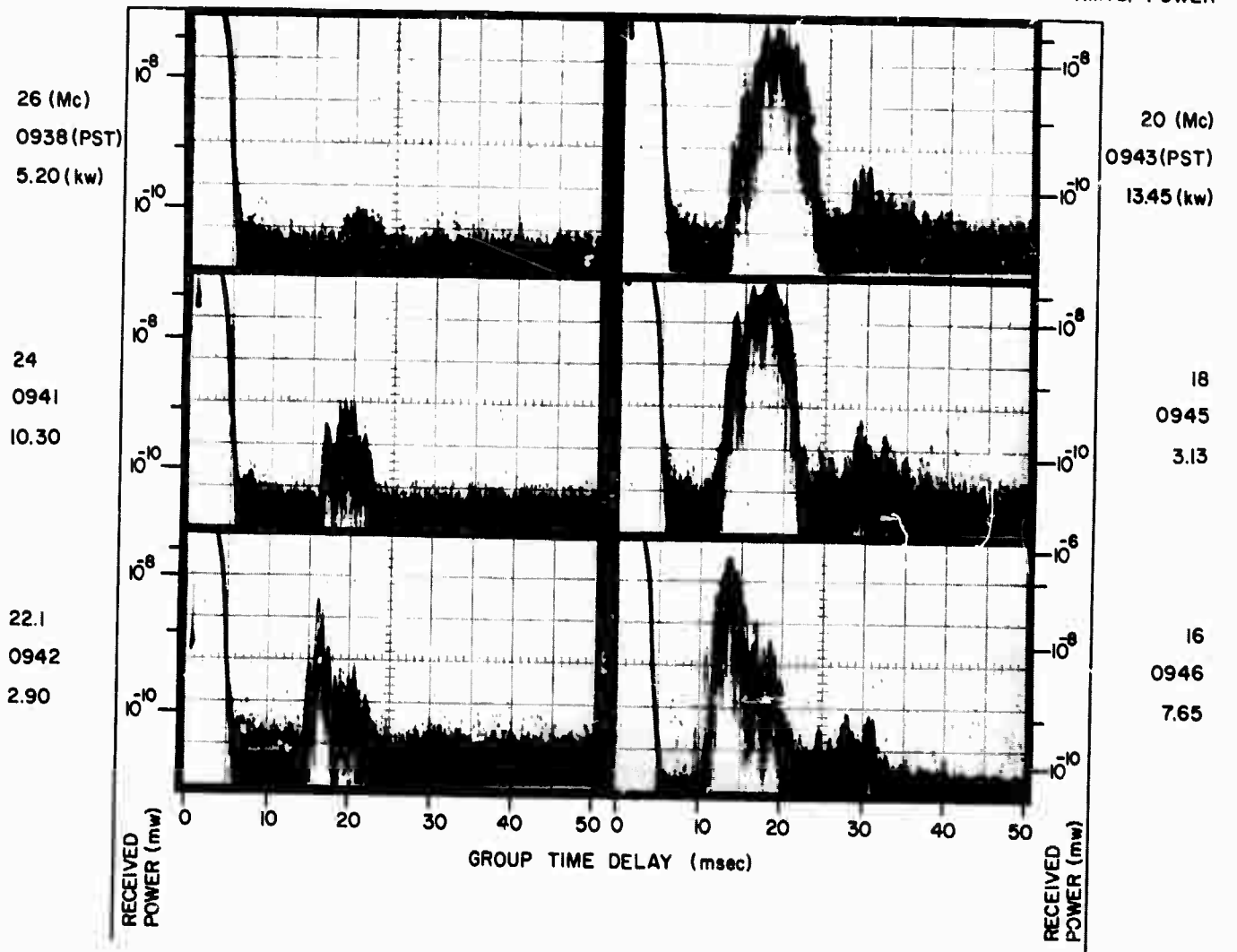

A RECORDS, 27 OCT 1964, 302° BEARING

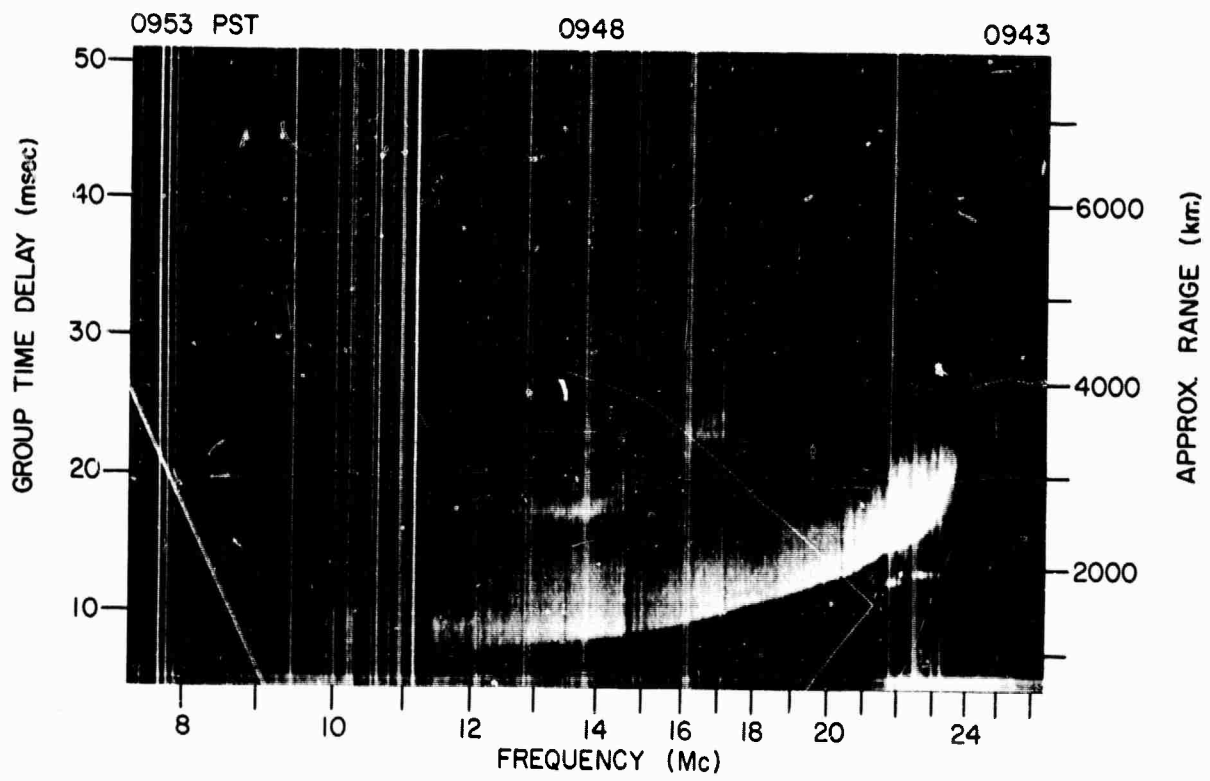
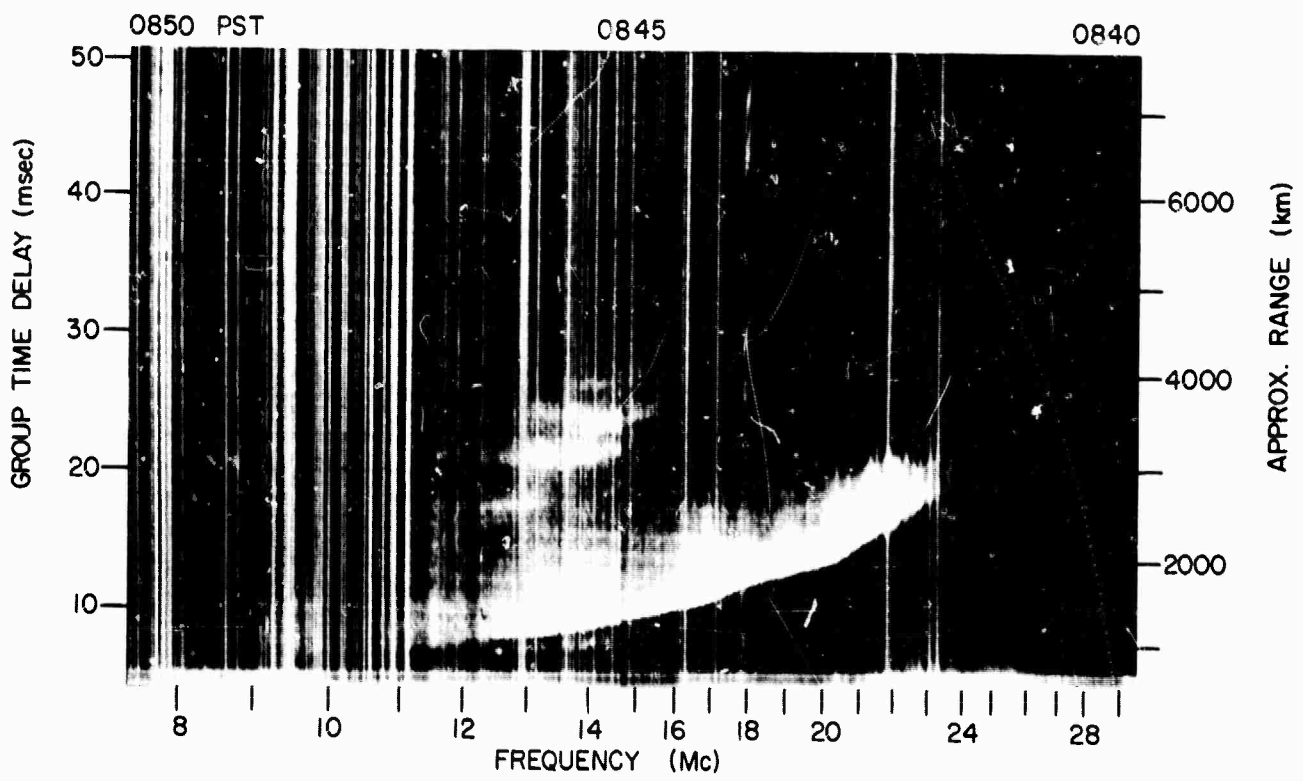
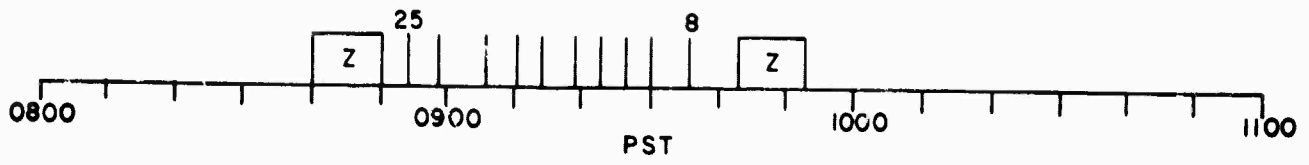

Z RECORDS, 3 NOV 1964, 302° BEARING

FREQ.  
TIME  
XMTD. POWER

FREQ.  
TIME  
XMTD. POWER

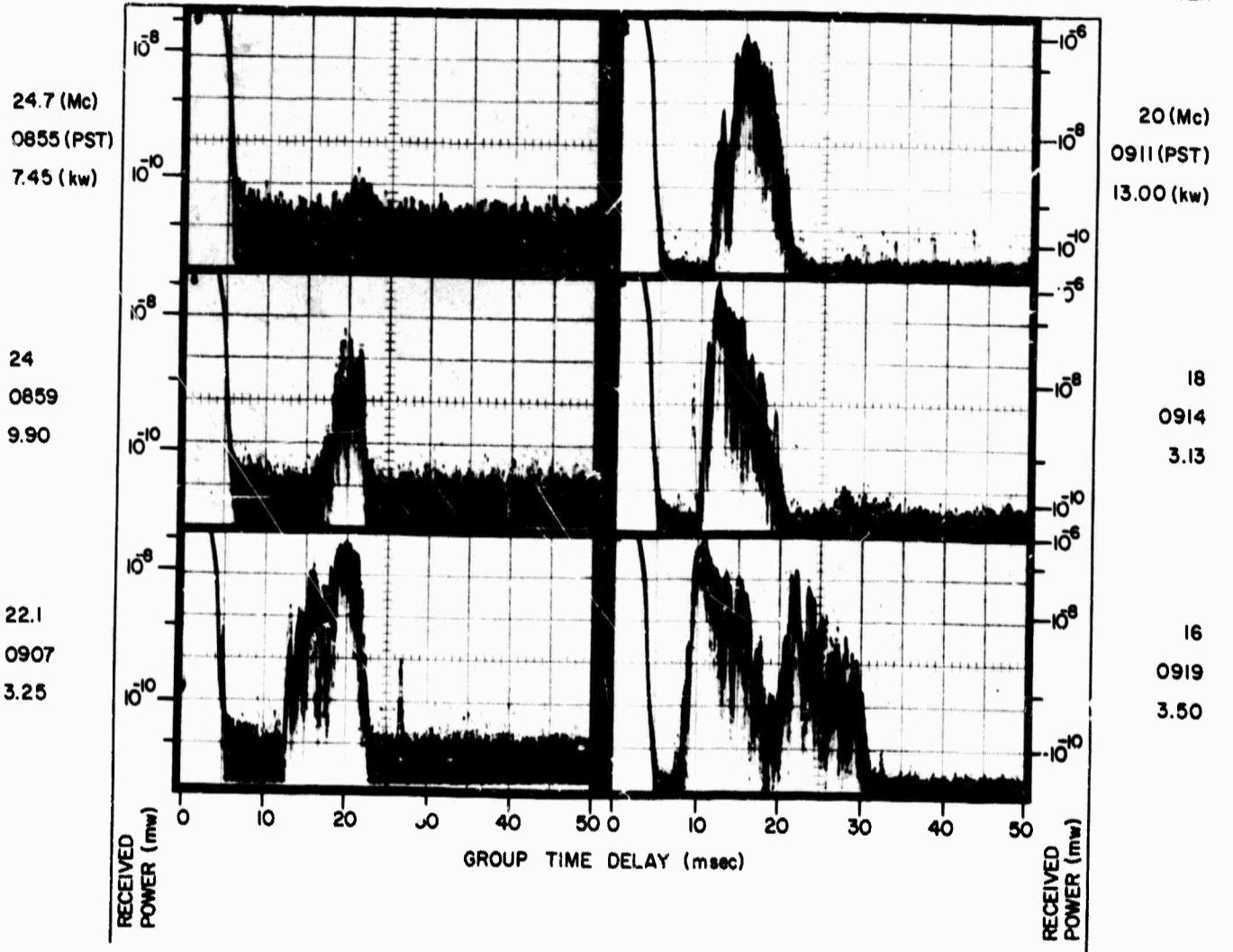

A RECORDS, 3 NOV 1964, 302° BEARING

FREQ.  
TIME  
XMTD. POWER

FREQ.  
TIME  
XMTD. POWER

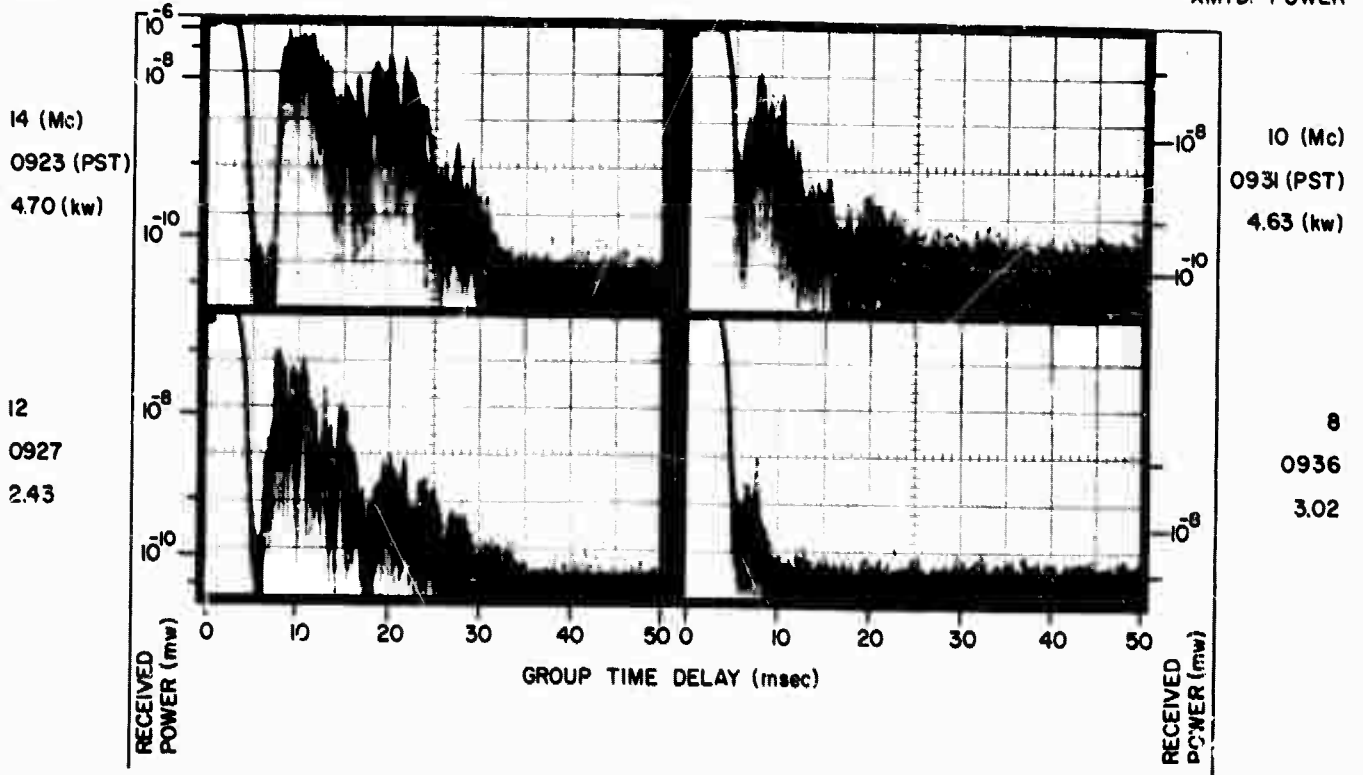

A RECORDS, 3 NOV 1964, 302° BEARING

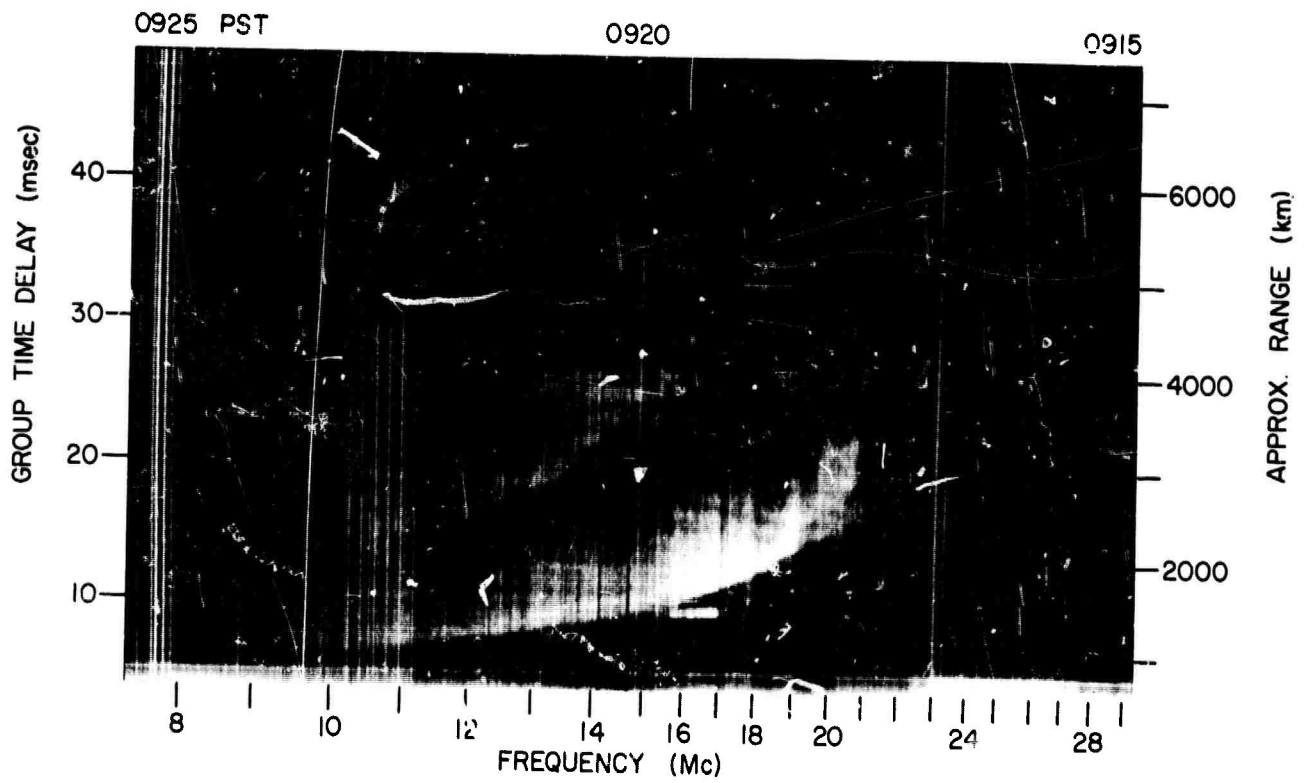
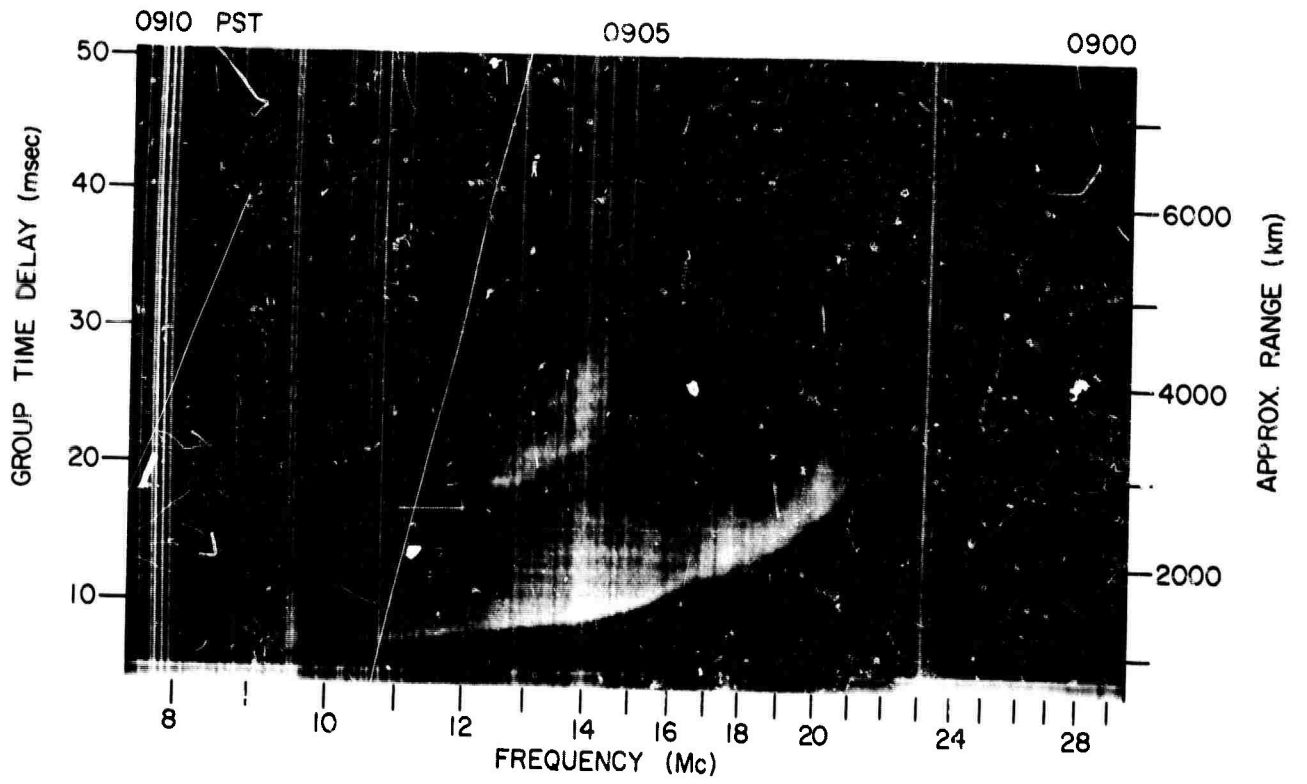

Z RECORDS, 7 NOV 1964, 302° BEARING

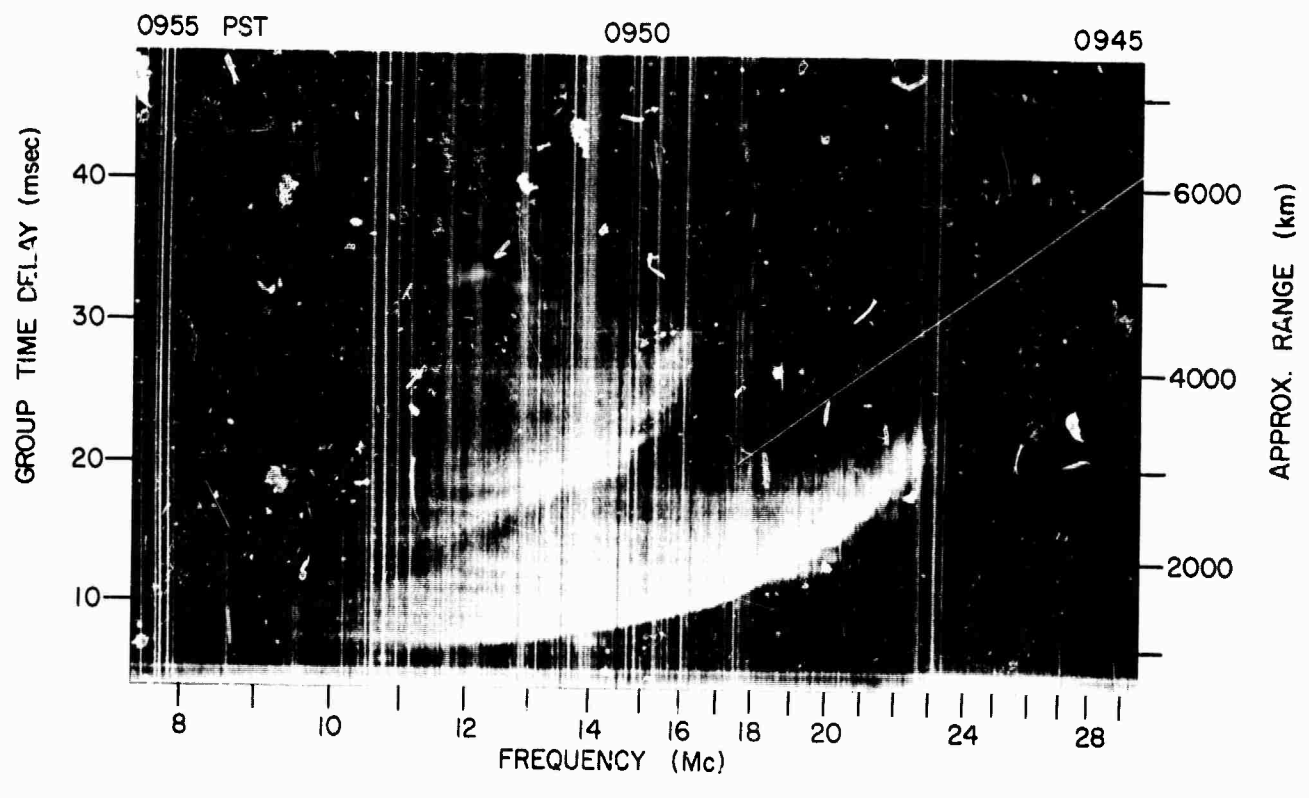
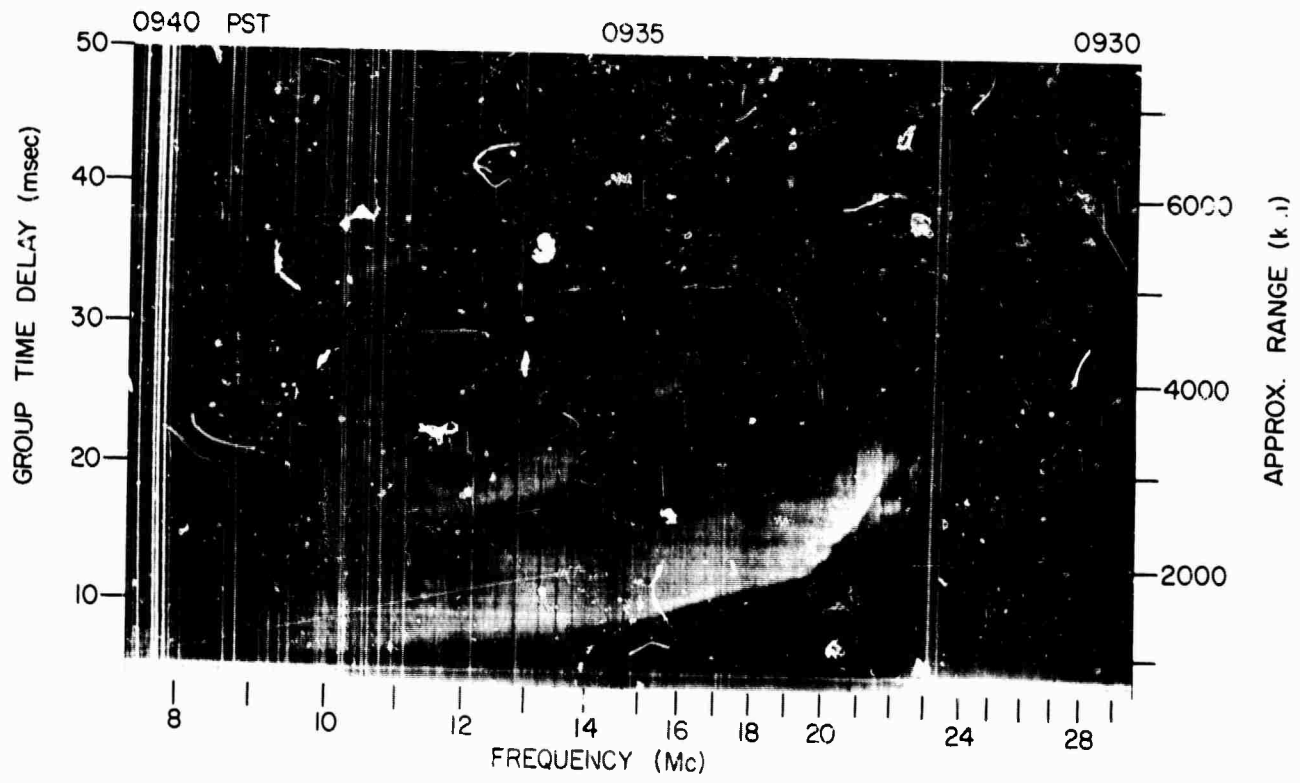

Z RECORDS, 7 NOV 1964, 302° BEARING

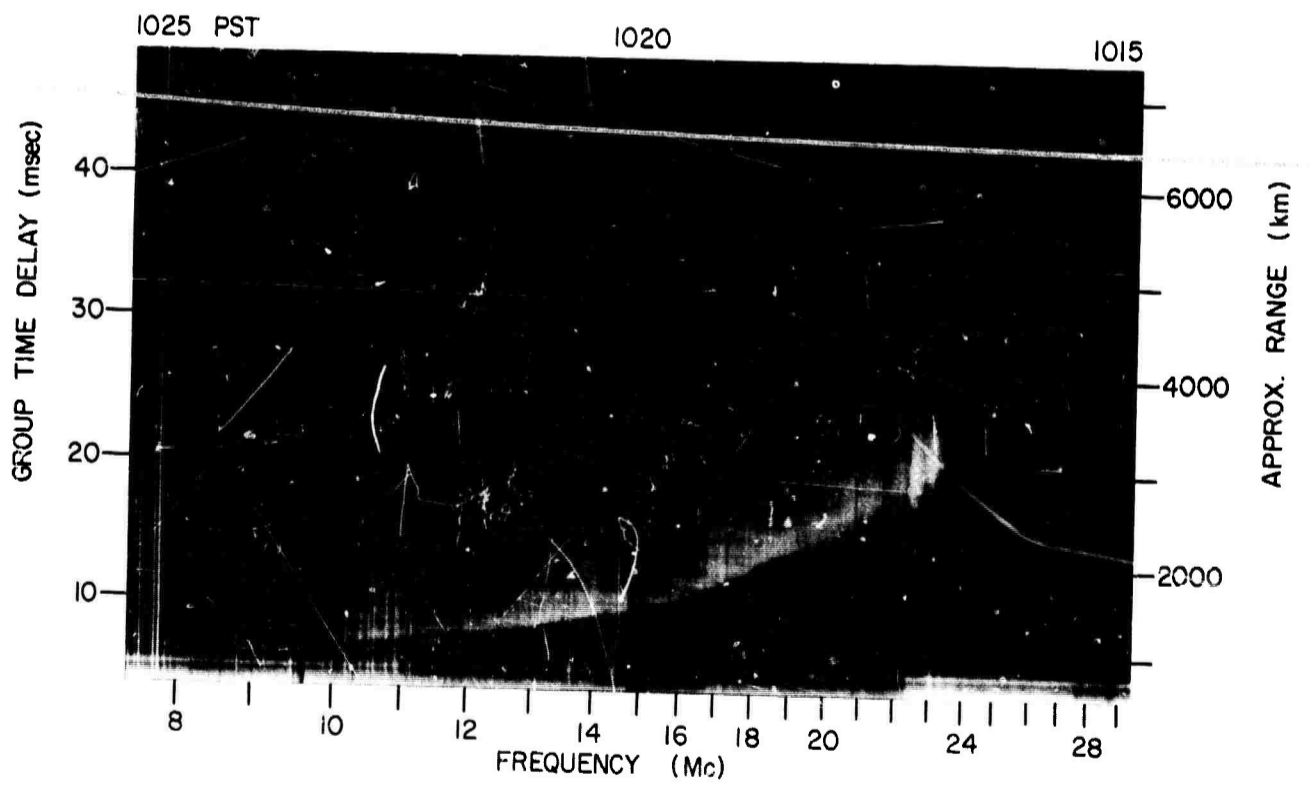
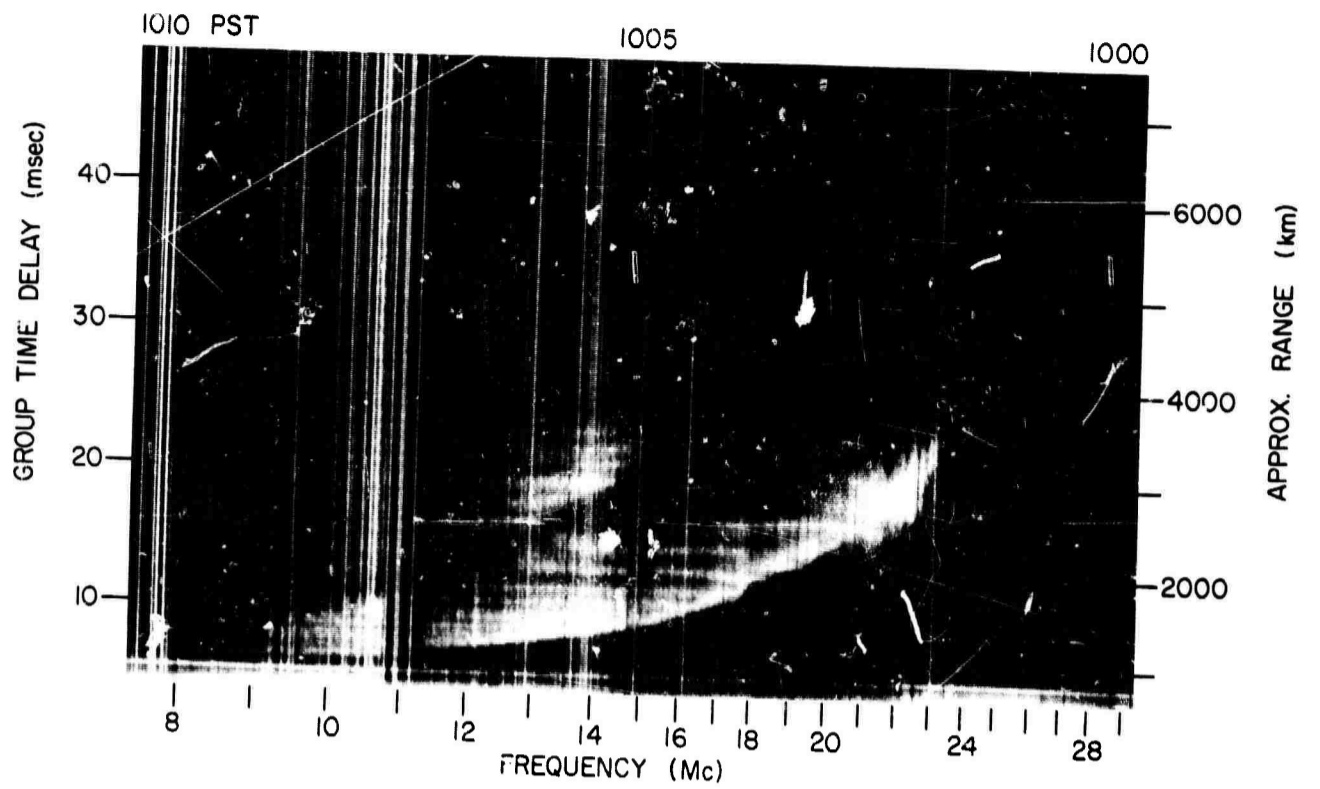

Z RECORDS, 7 NOV 1964, 302° BEARING

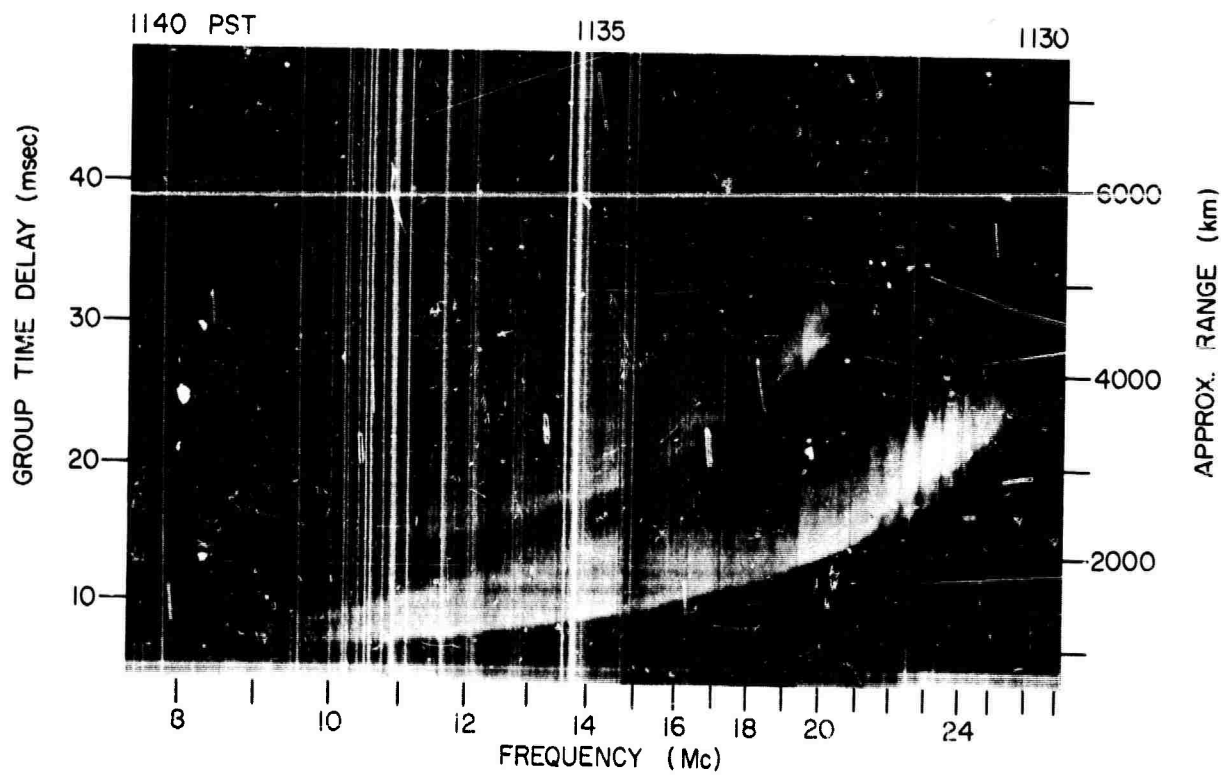
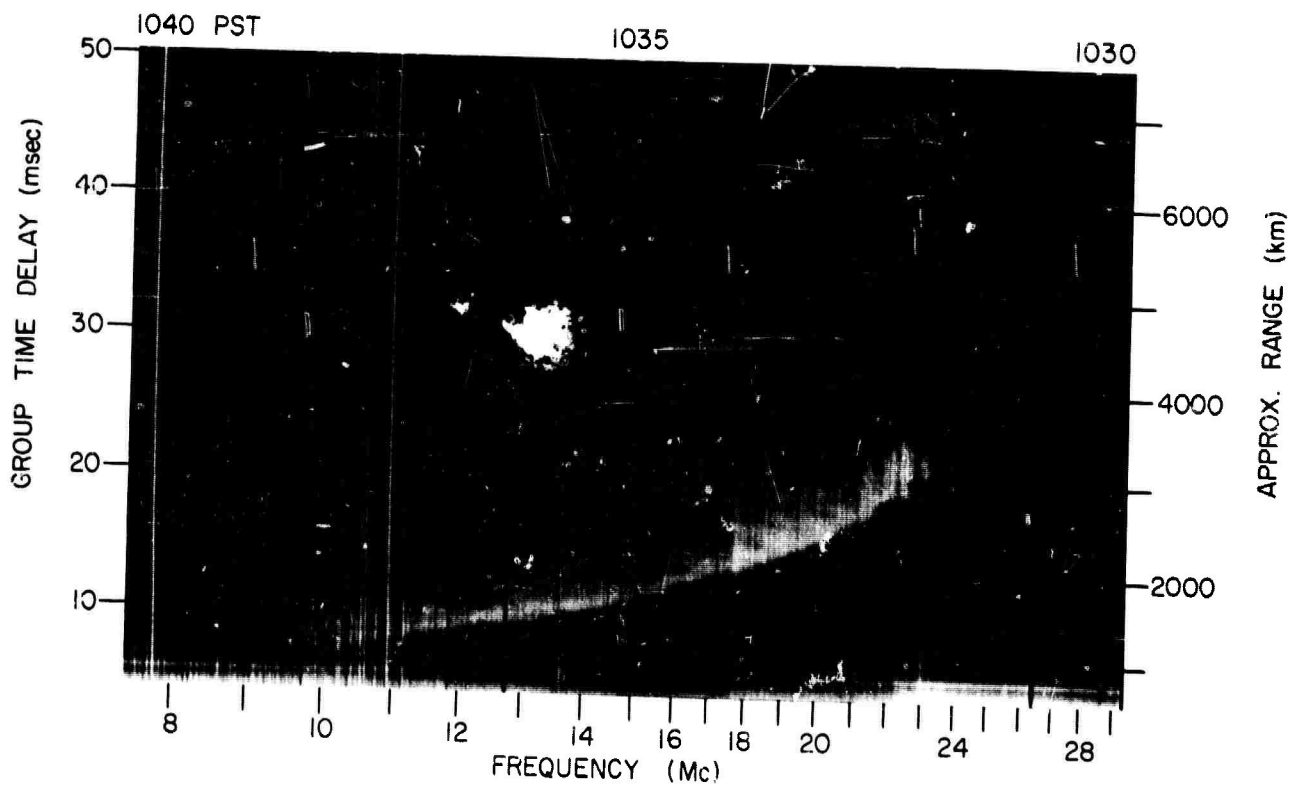

Z RECORDS, 7 NOV 1964, 302° BEARING

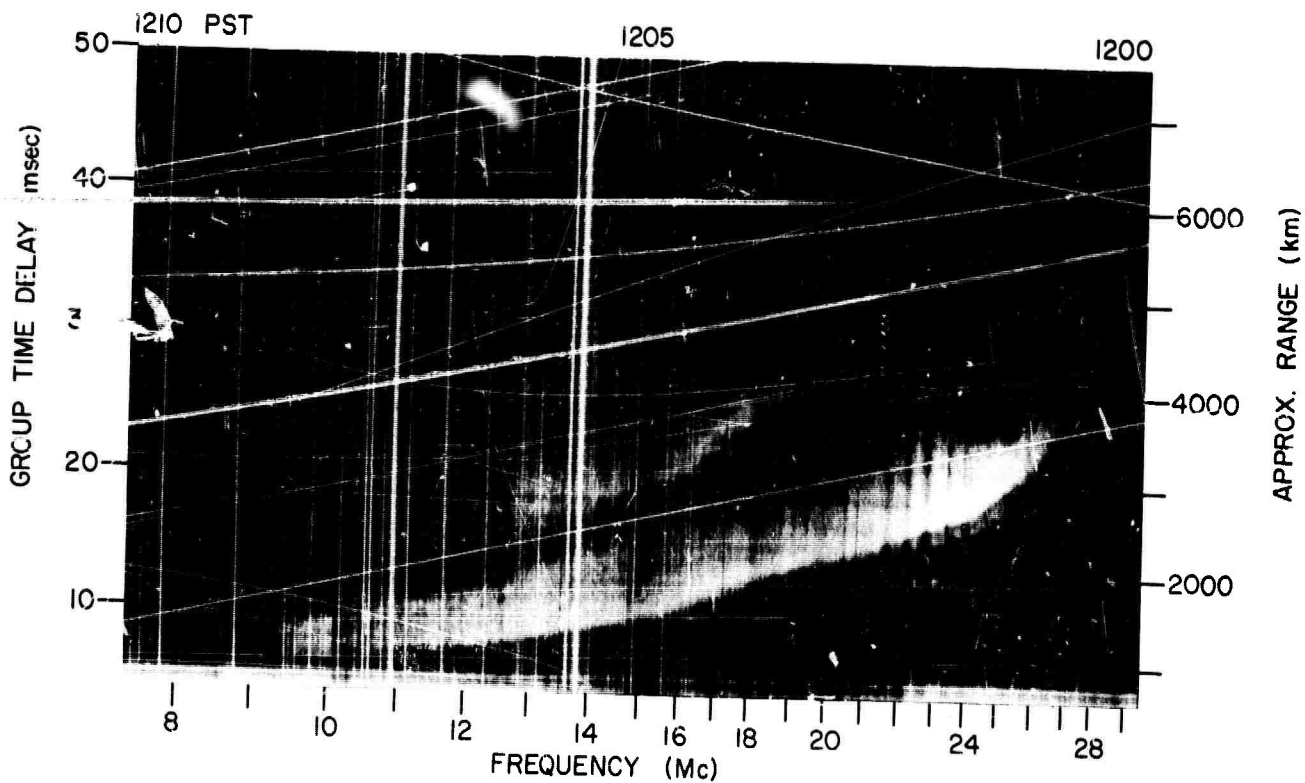
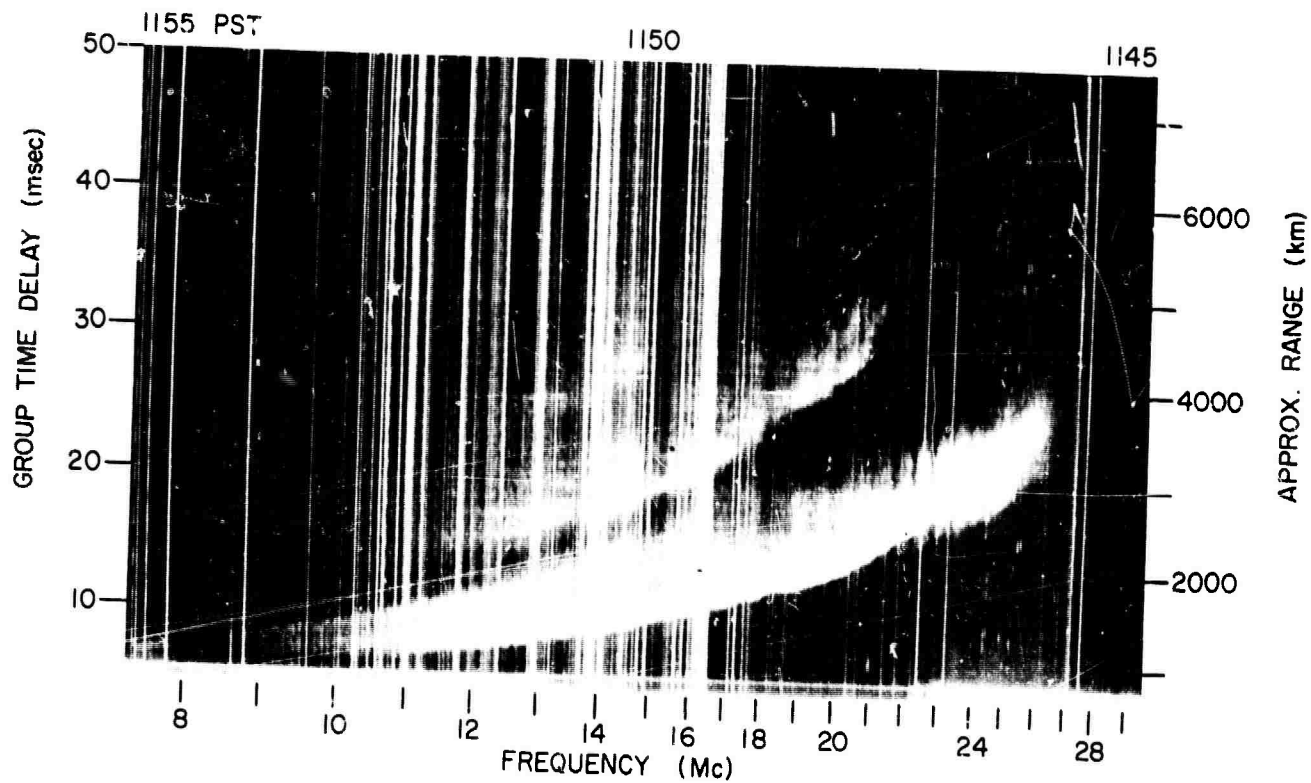

Z RECORDS, 7 NOV 1964, 302° BEARING

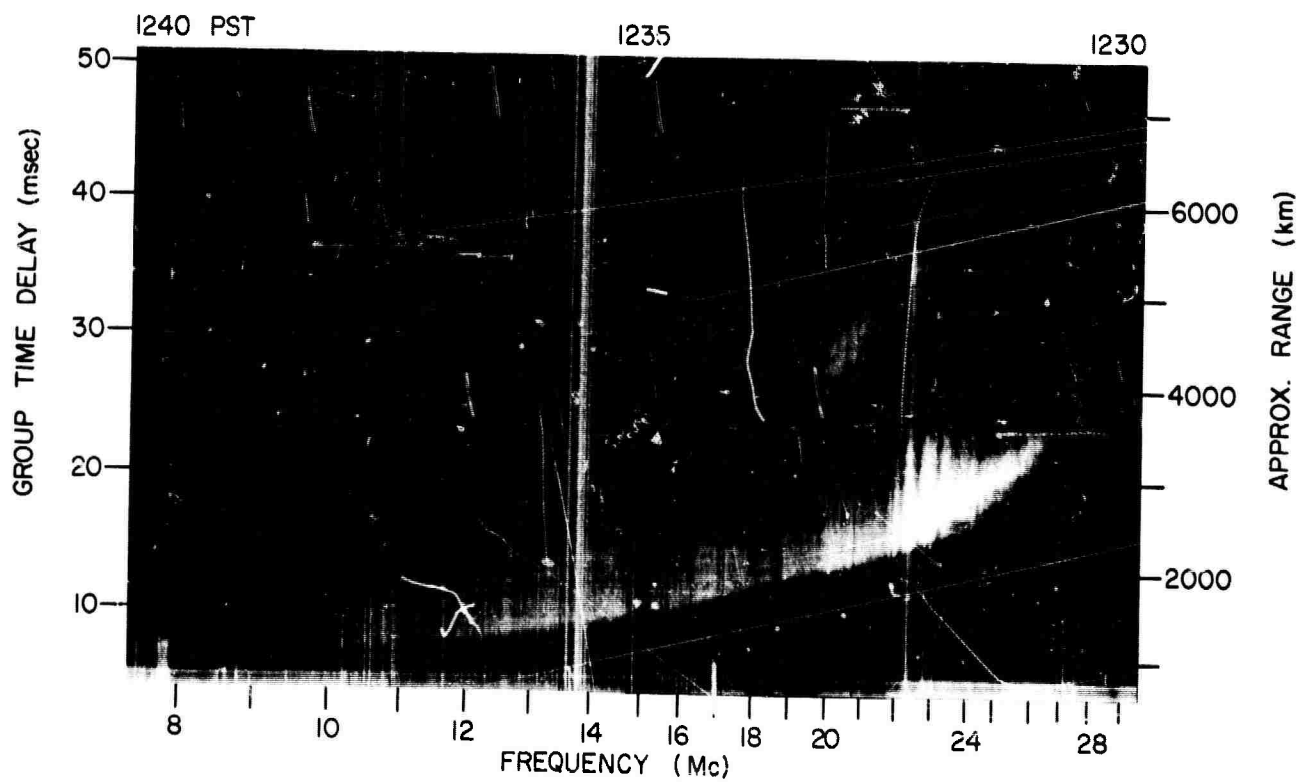
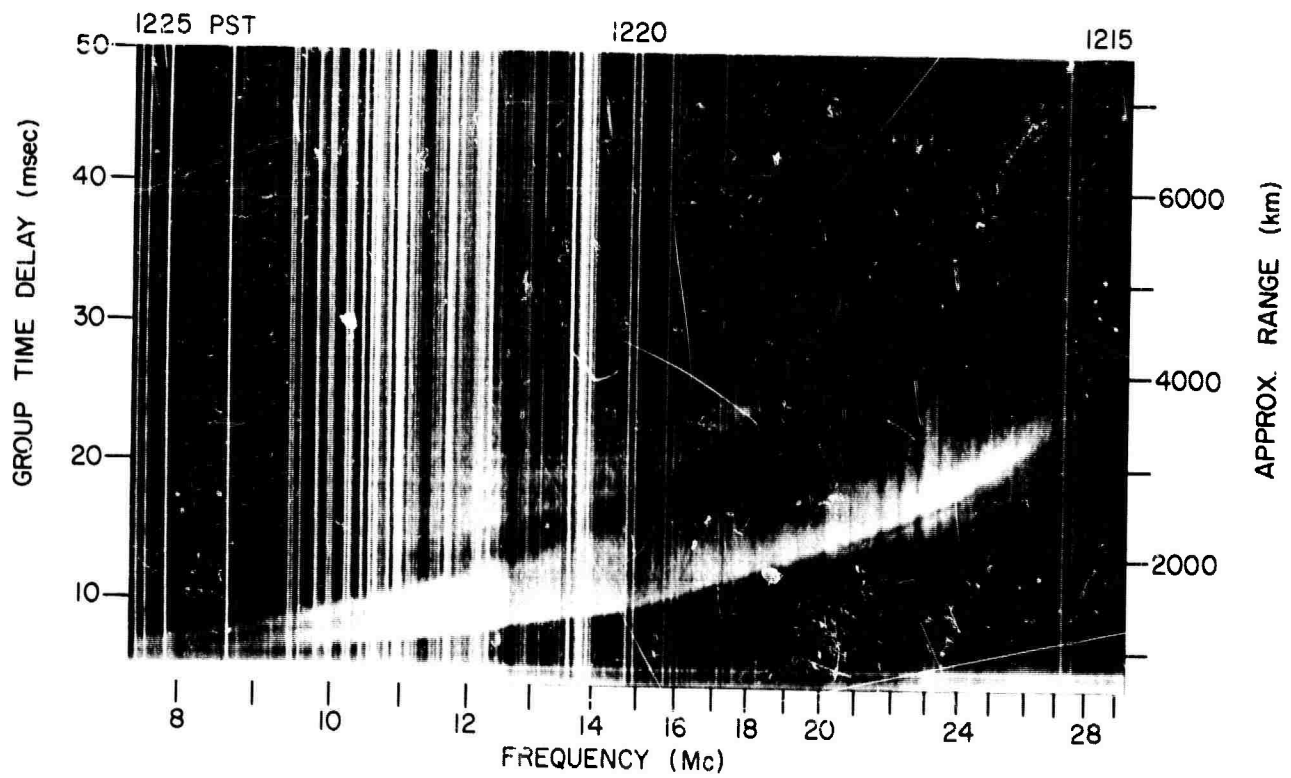

Z RECORDS, 7 NOV 1964, 302° BEARING

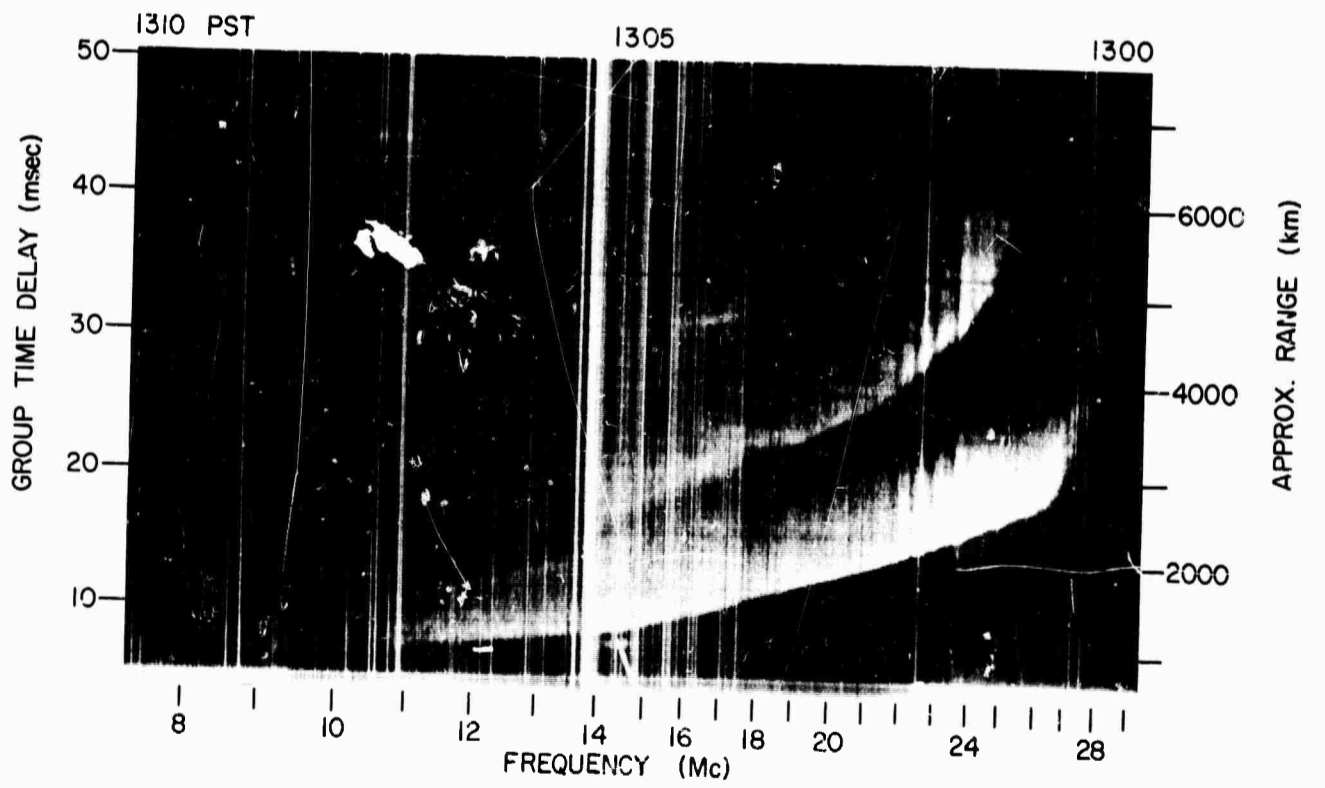
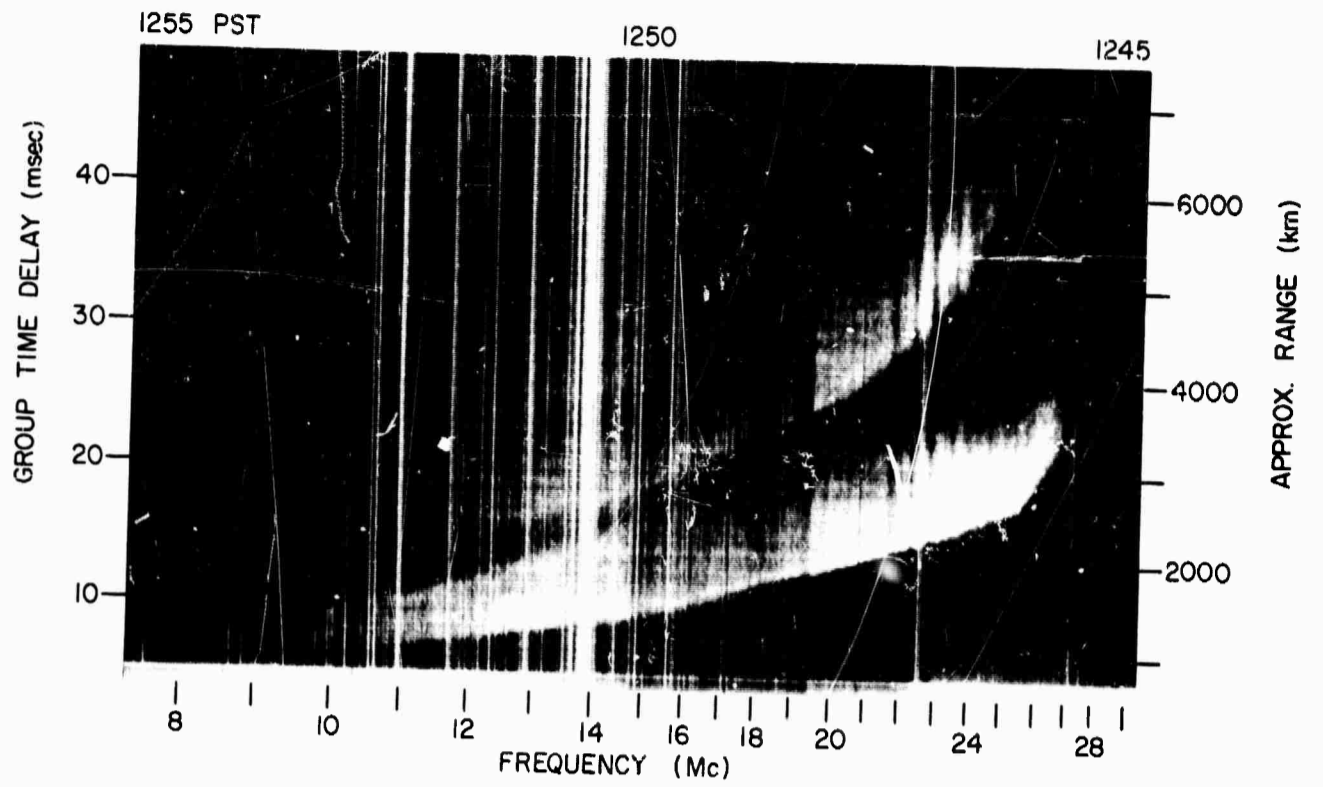

Z RECORDS, 7 NOV 1964, 302° BEARING

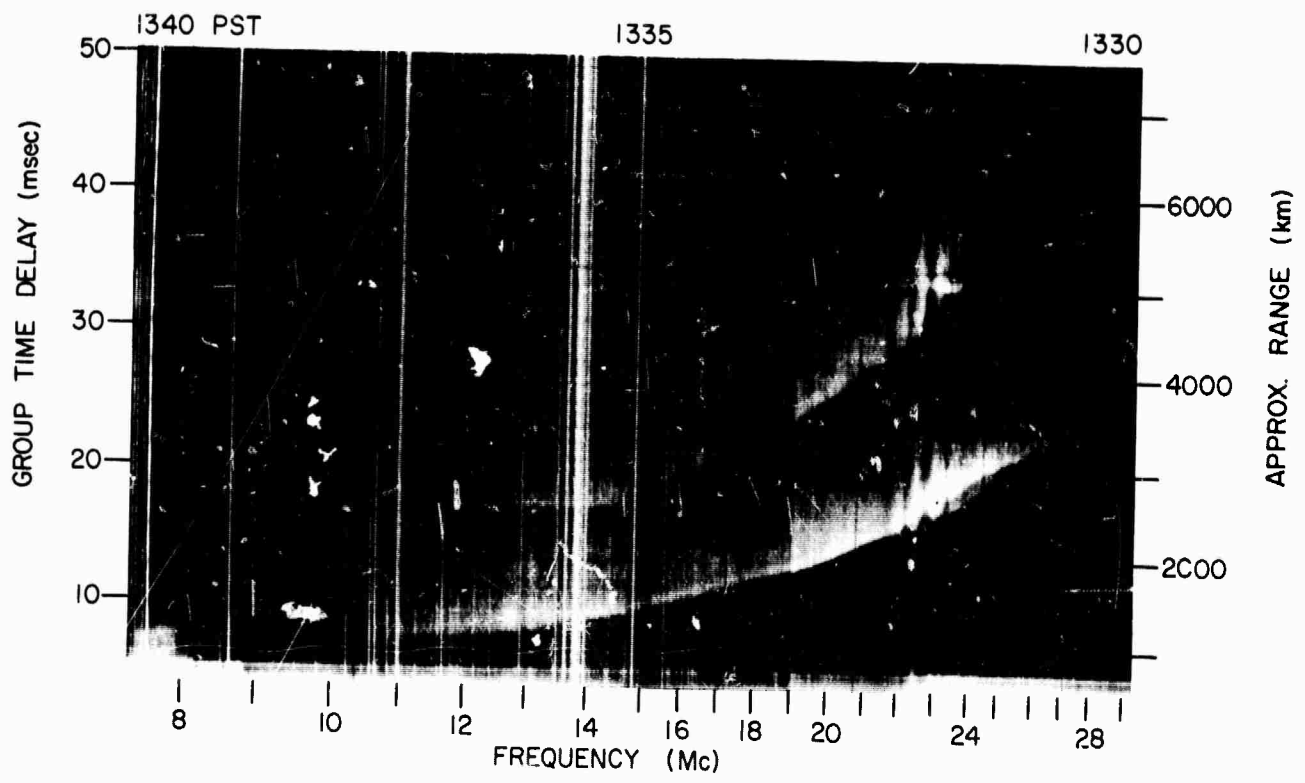
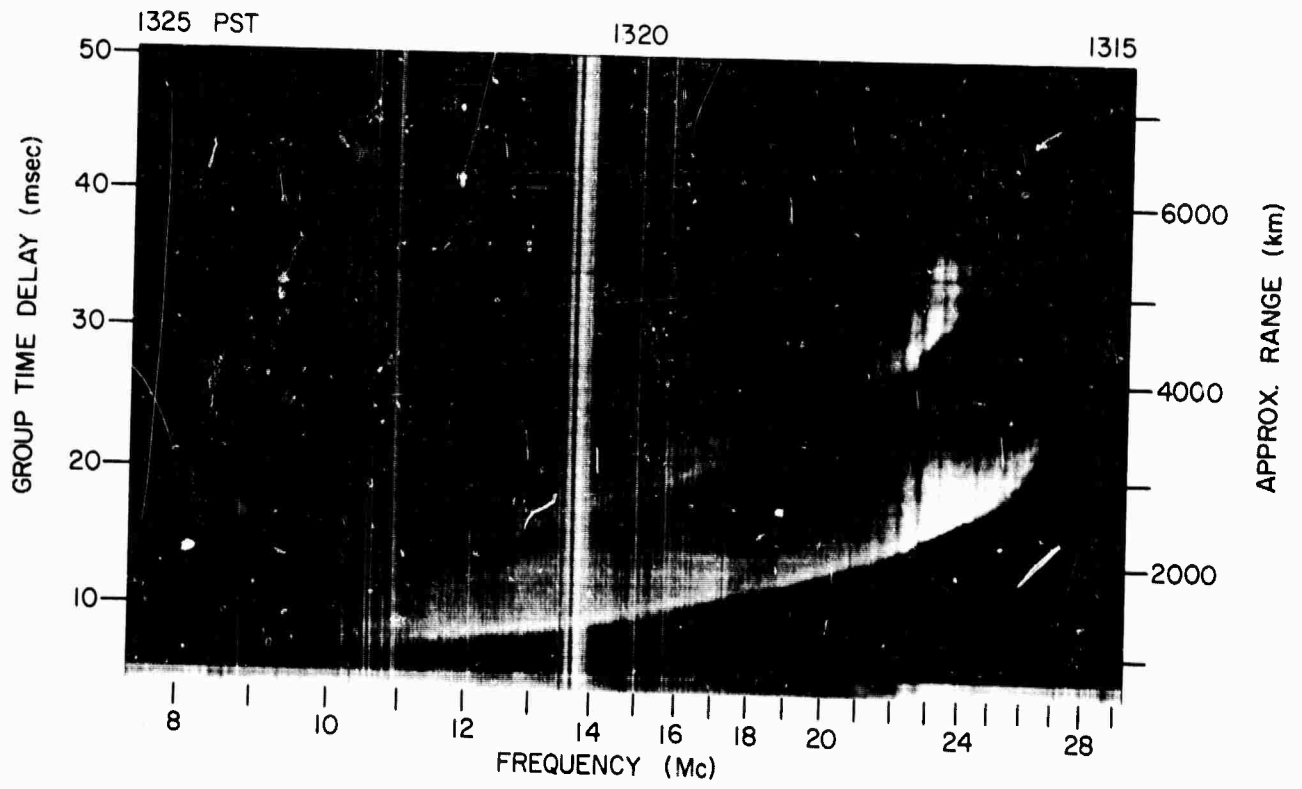

Z RECORDS, 7 NOV 1964, 302° BEARING

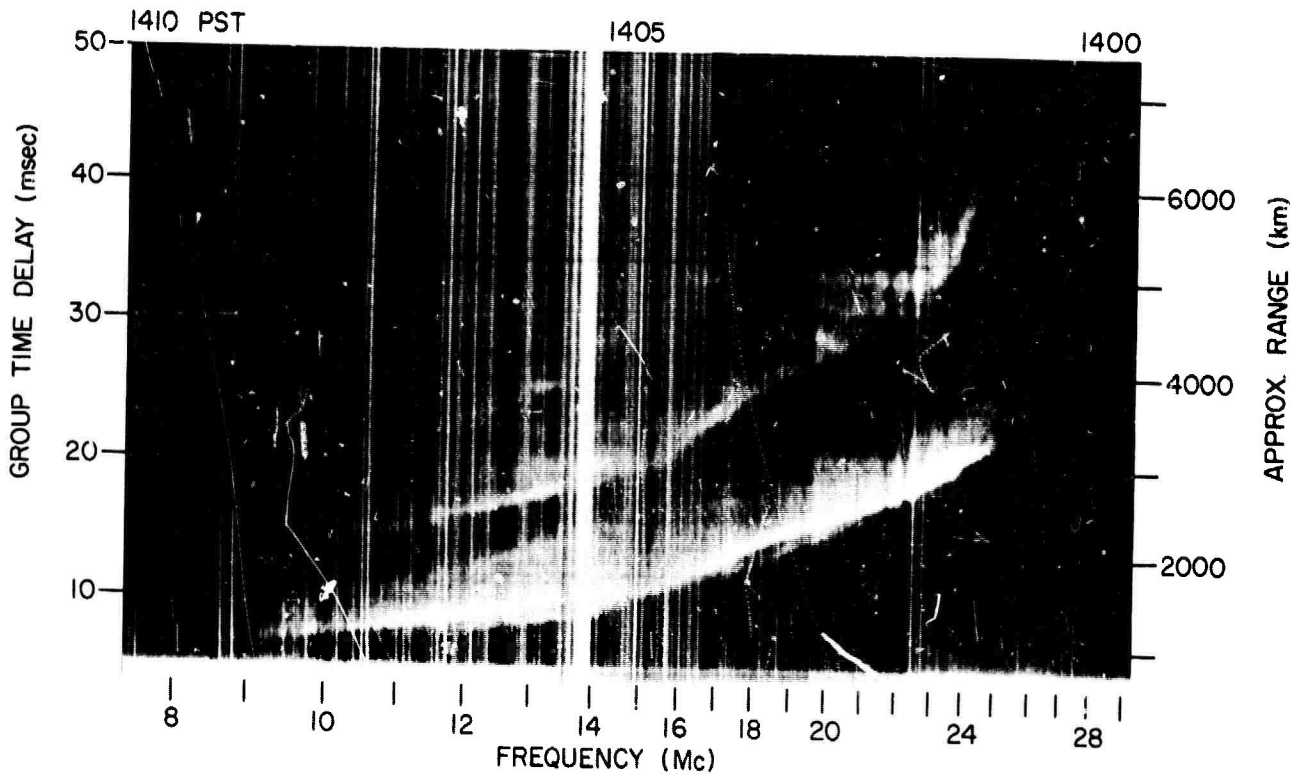
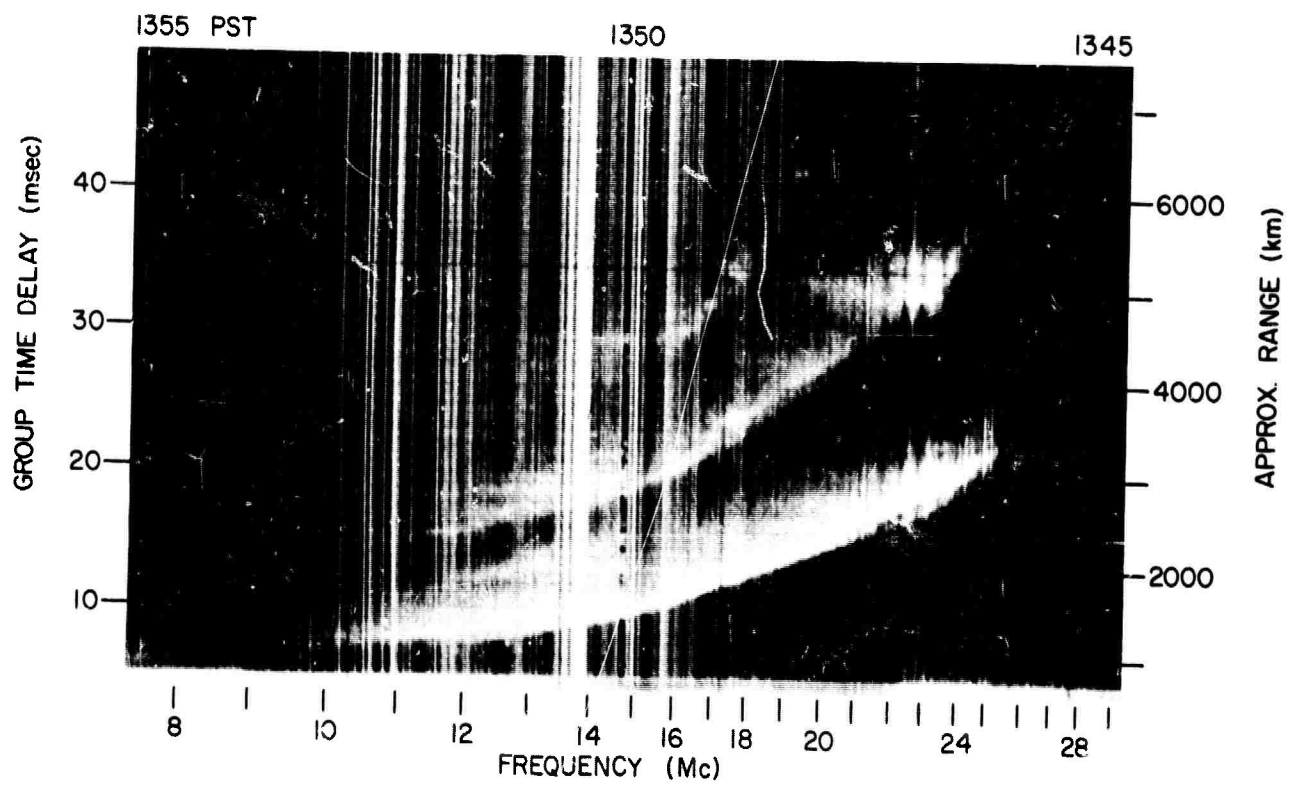

Z RECORDS, 7 NOV 1964, 302° BEARING

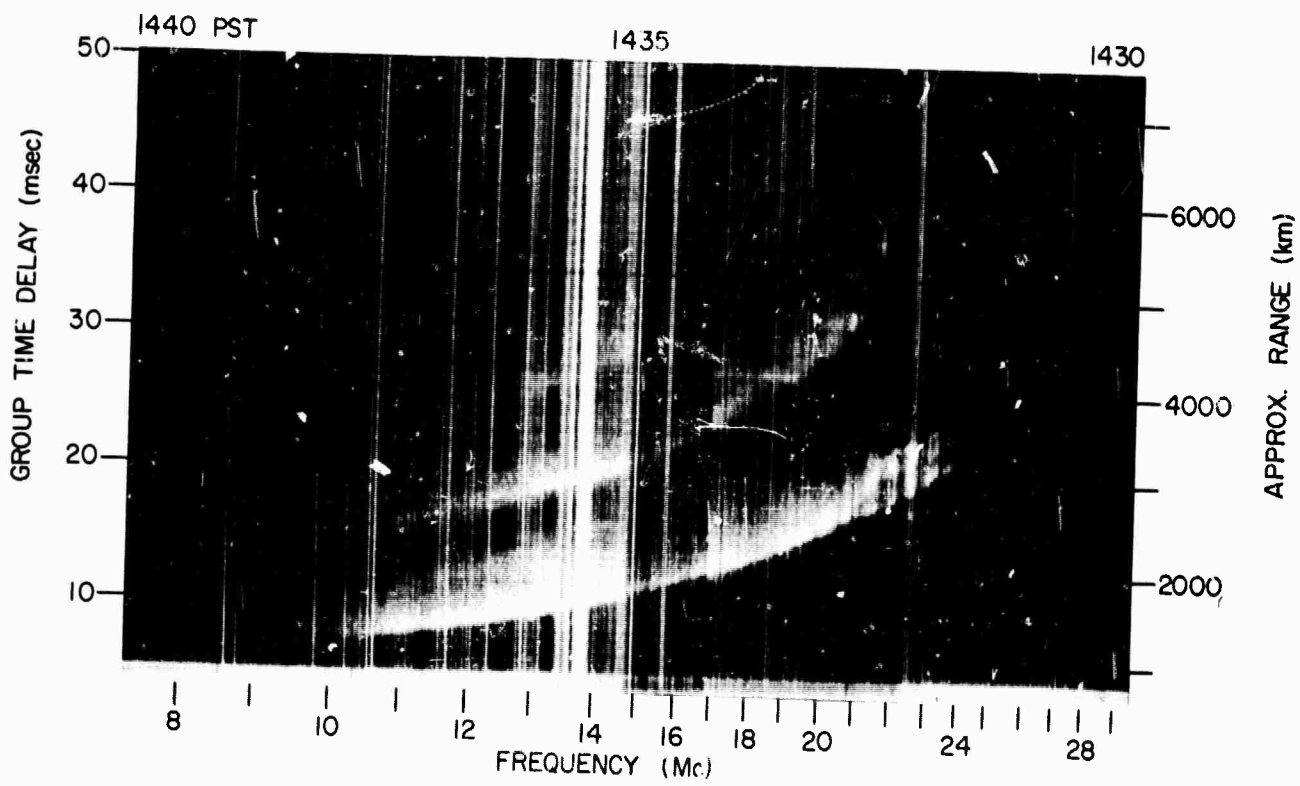
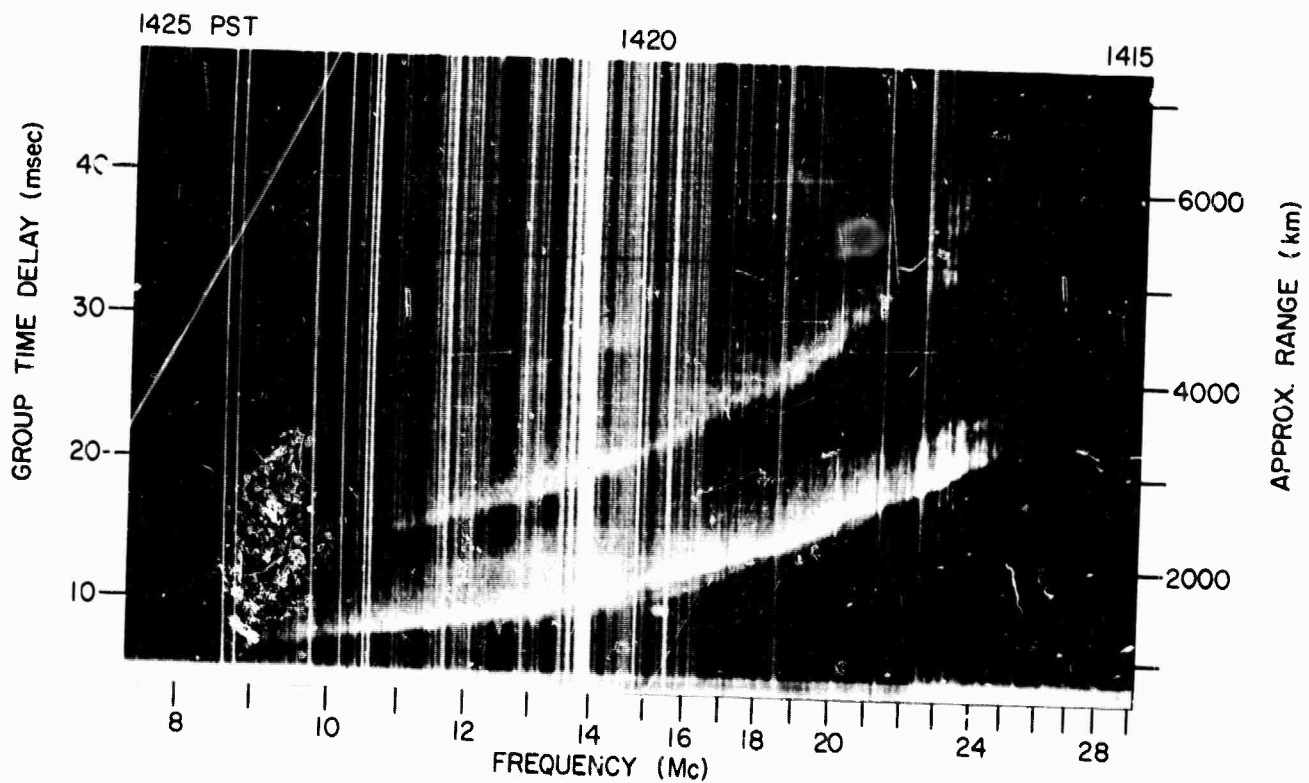

Z RECORDS, 7 NOV 1964, 302° BEARING

SEL-65-095

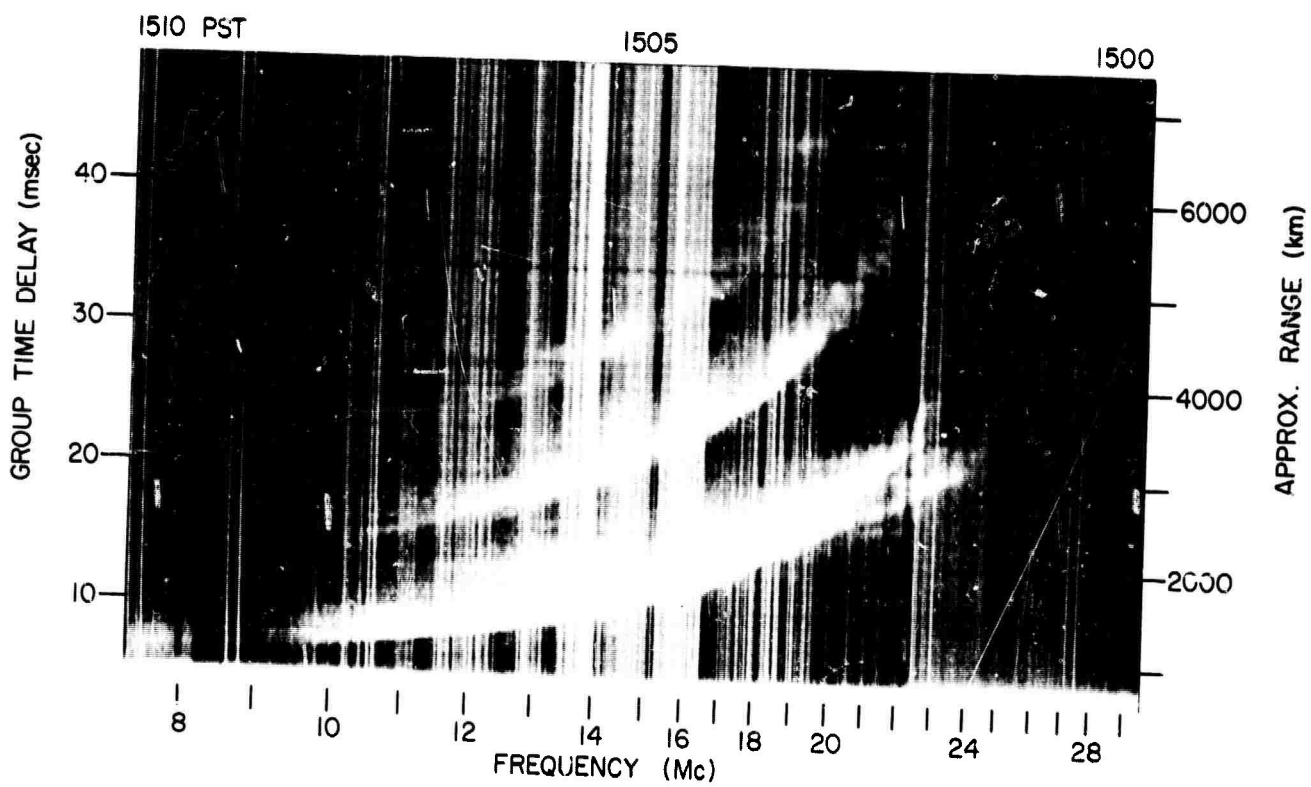
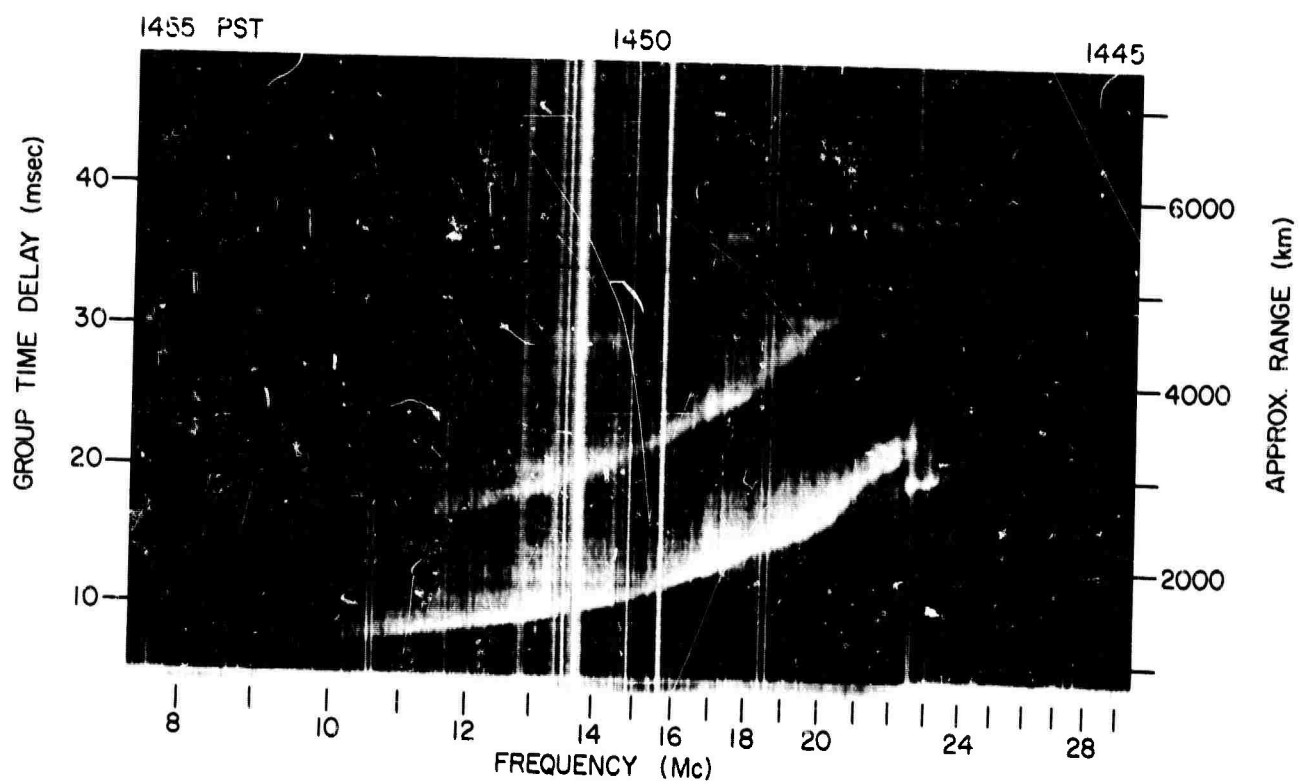

Z RECORDS, 7 NOV 1964, 302° BEARING

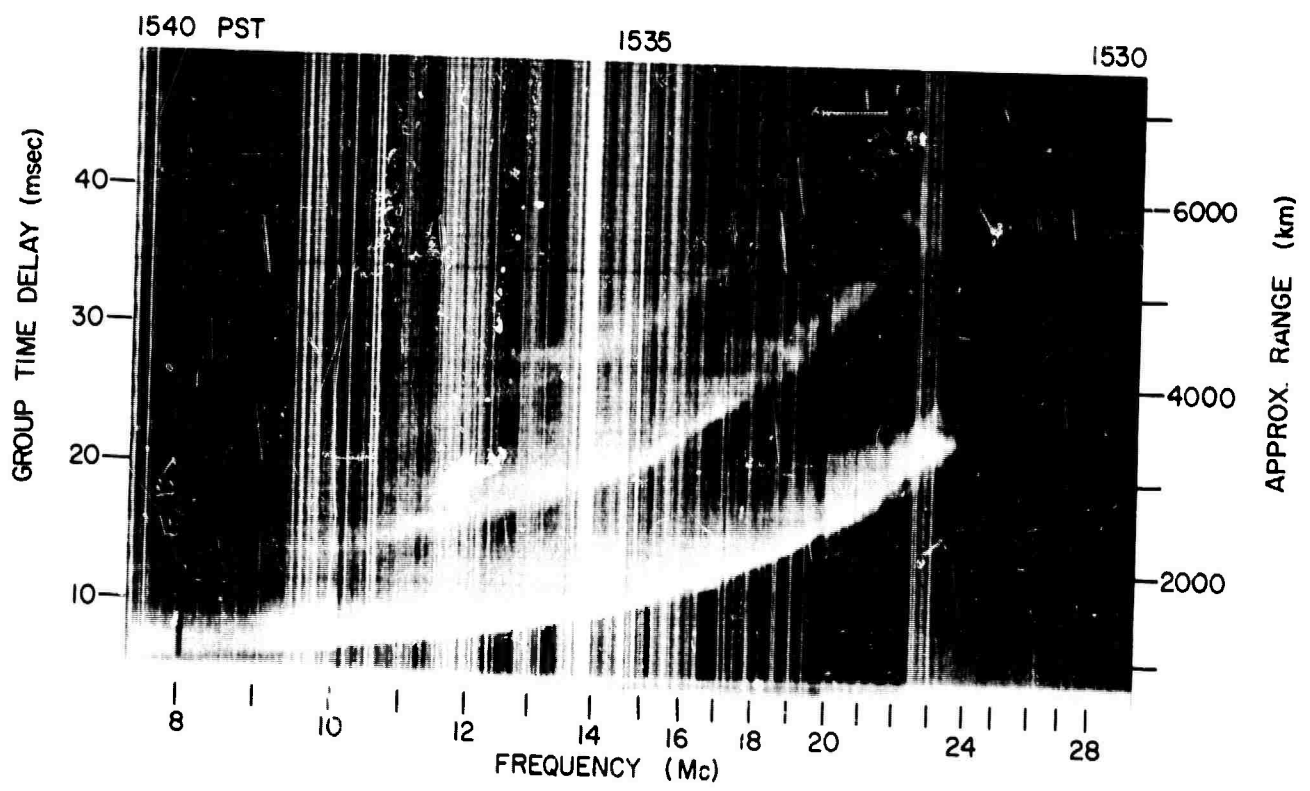
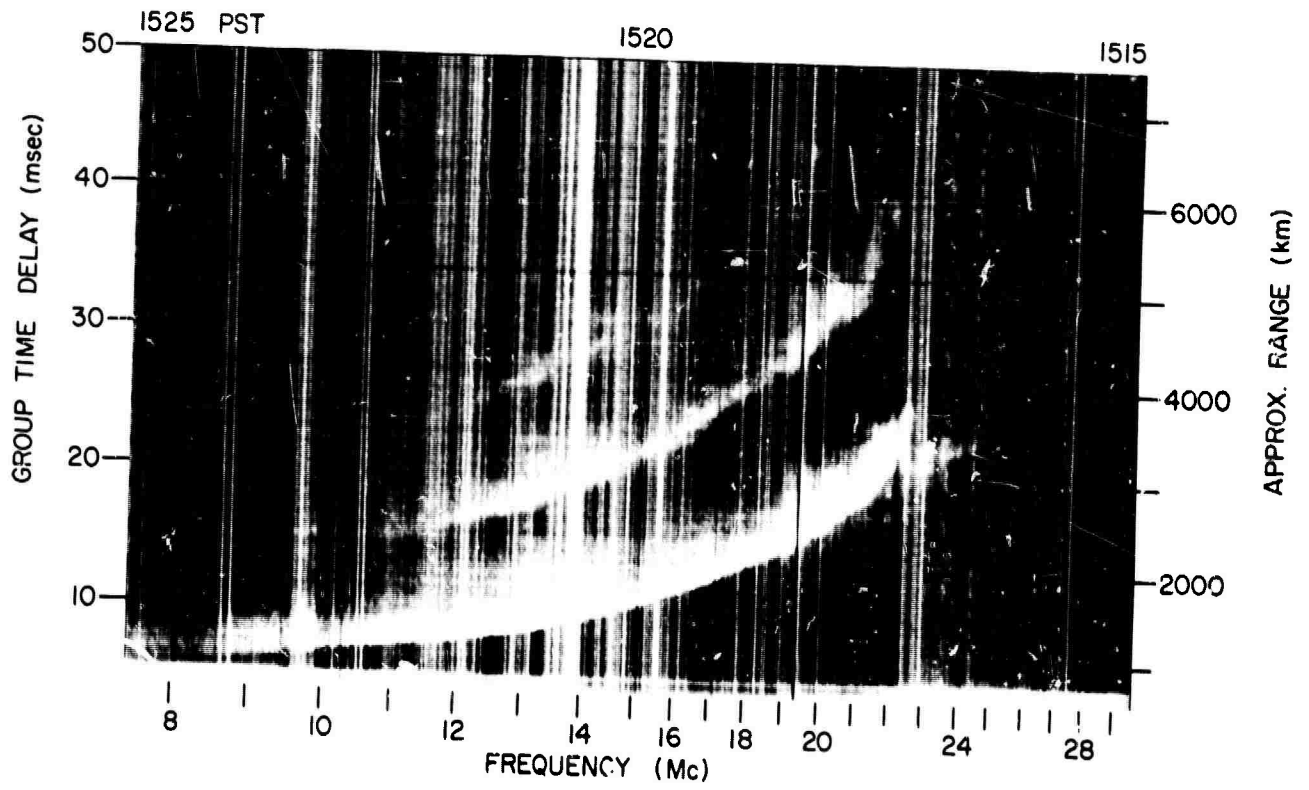

Z RECORDS, 7 NOV 1964, 302° BEARING

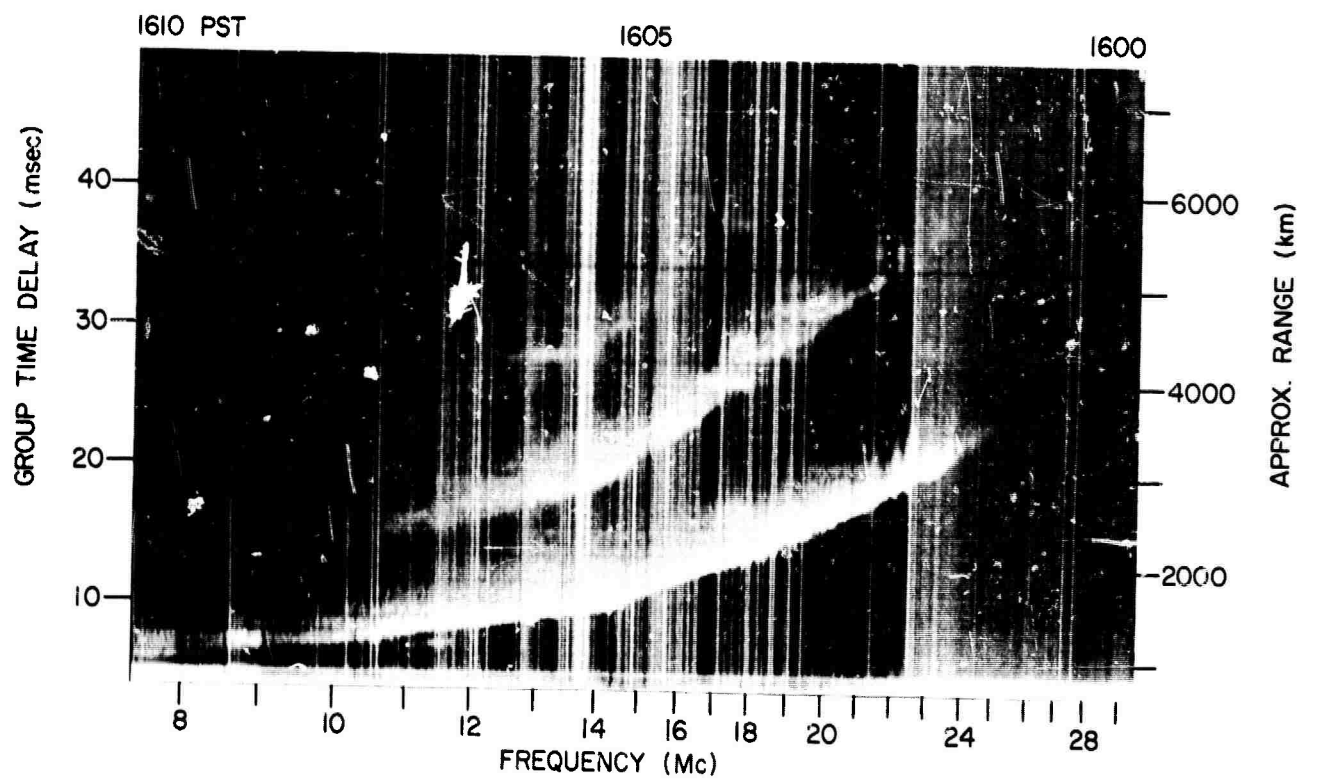
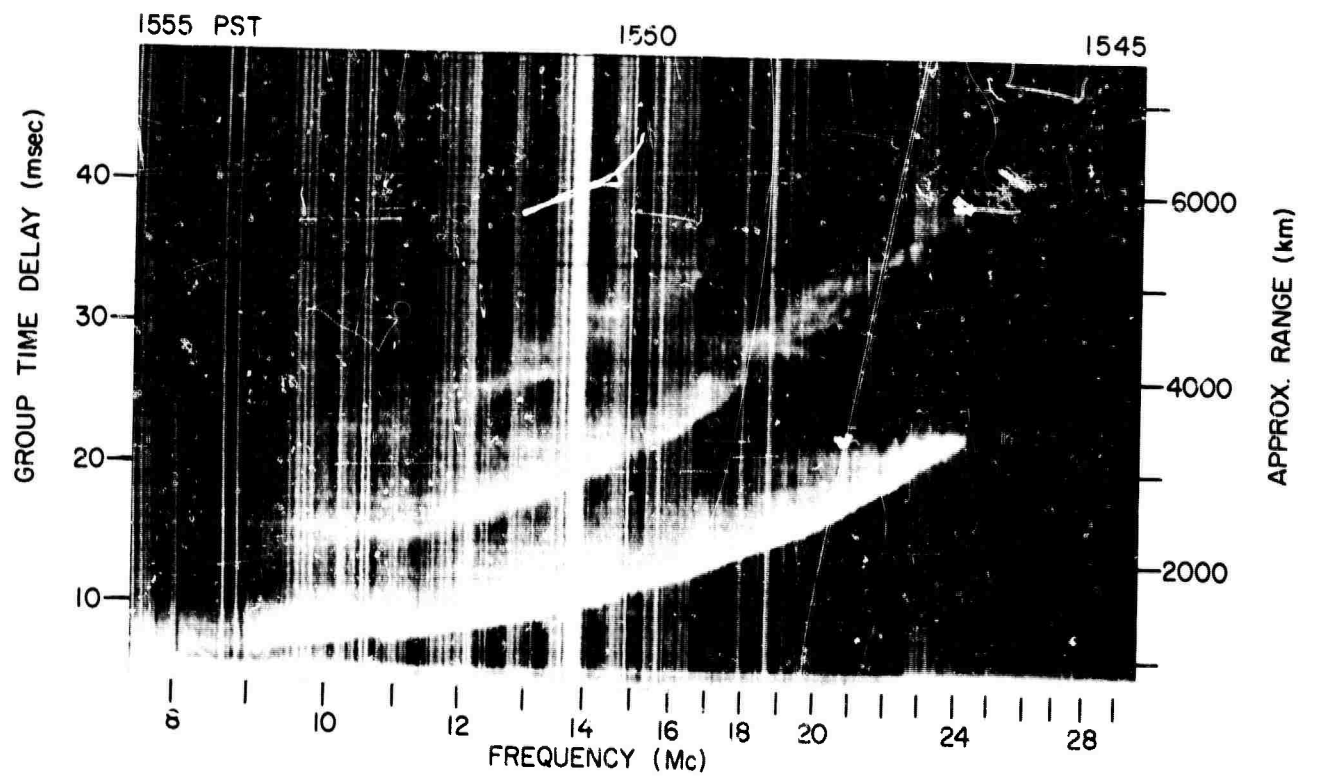

Z RECORDS, 7 NOV 1964, 302° BEARING



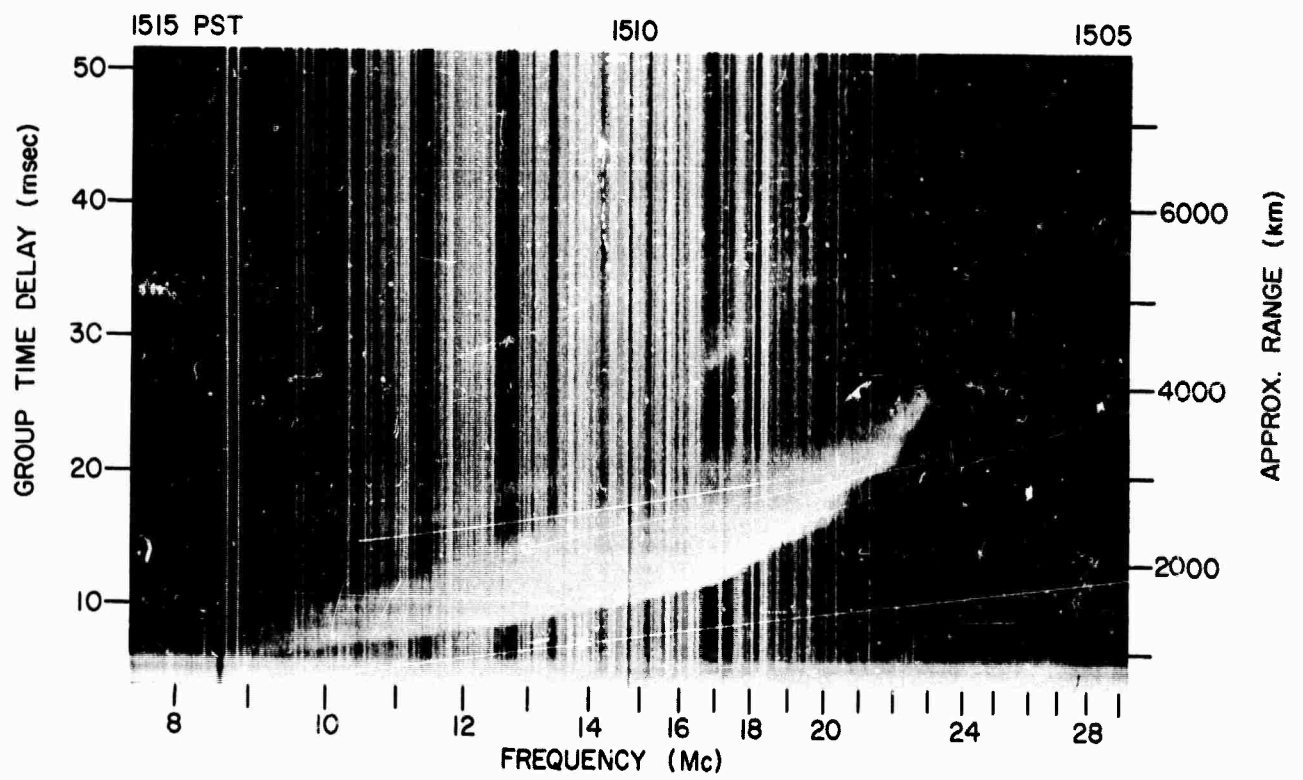
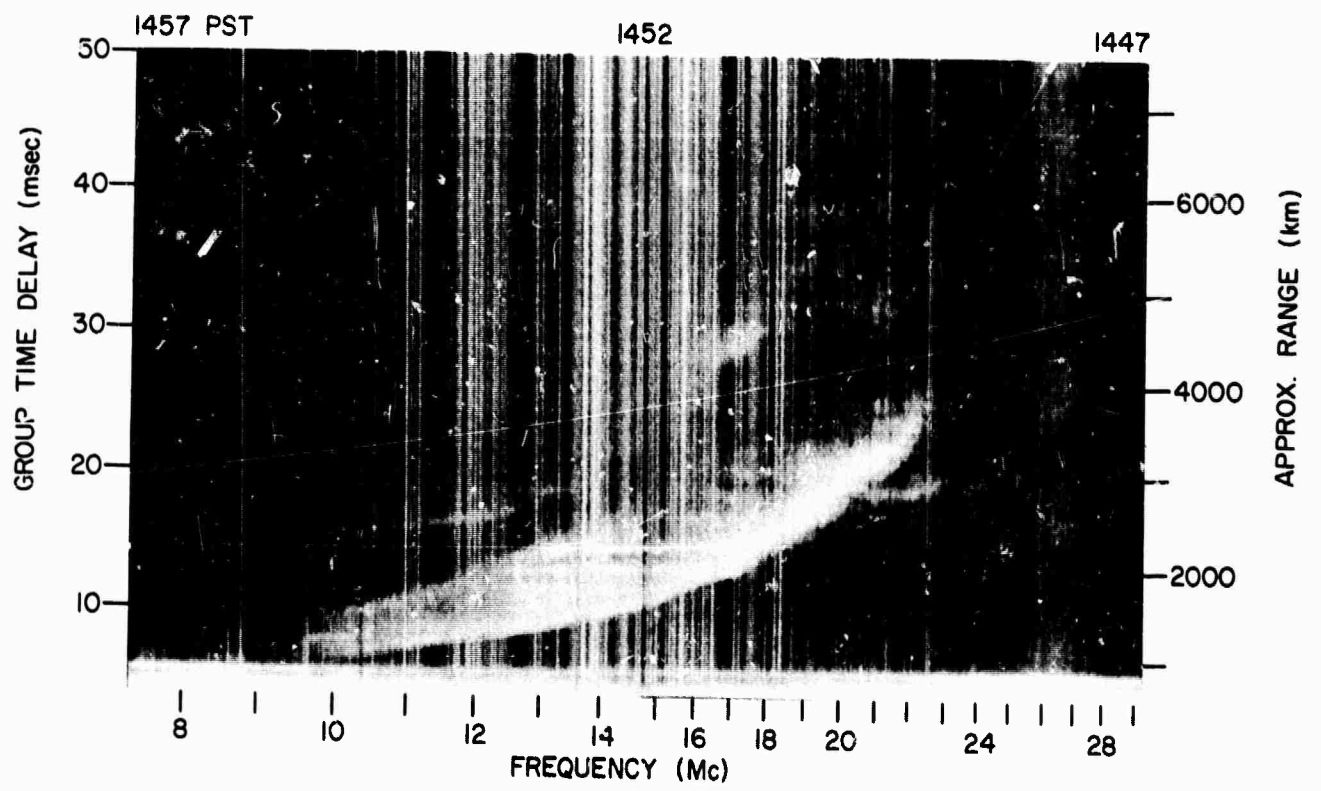

Z RECORDS, 16 FEB 1965, 122° BEARING

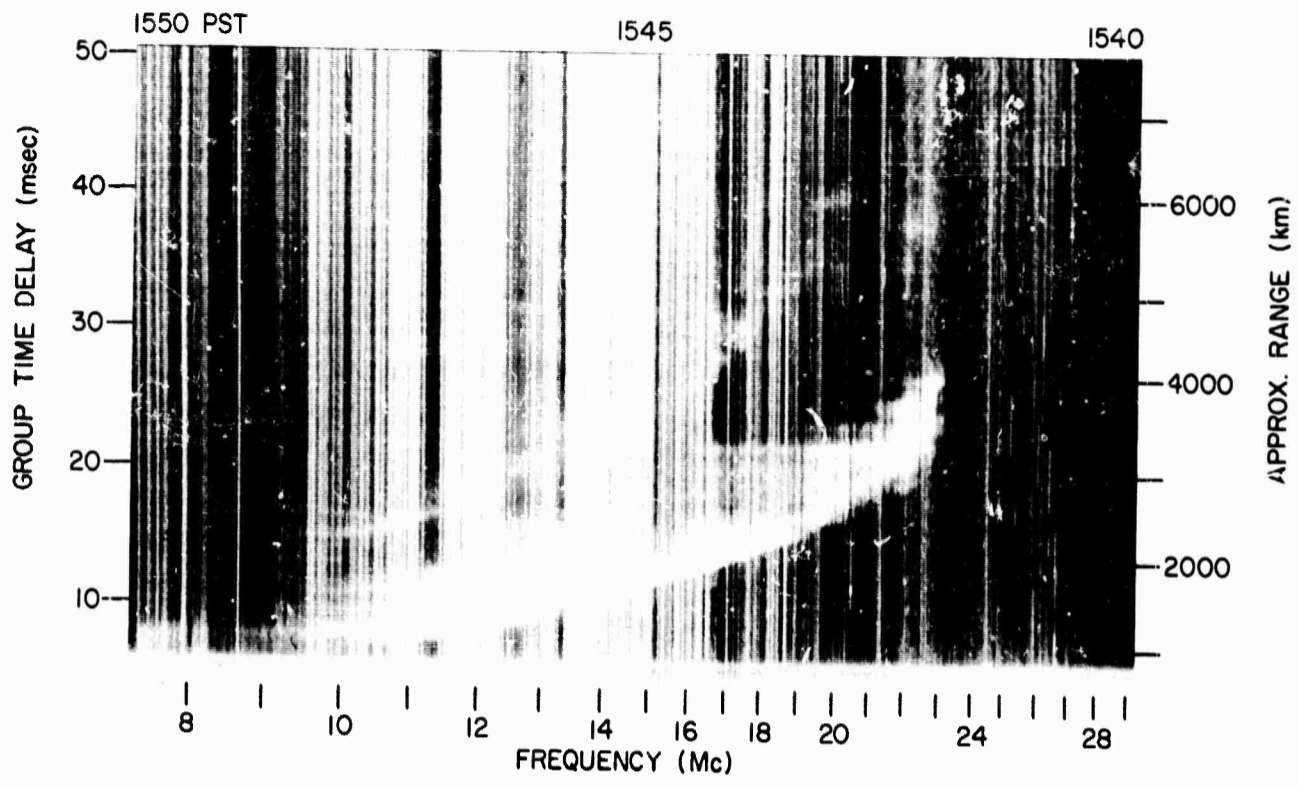

Z RECORD, 16 FEB 1965, 122° BEARING

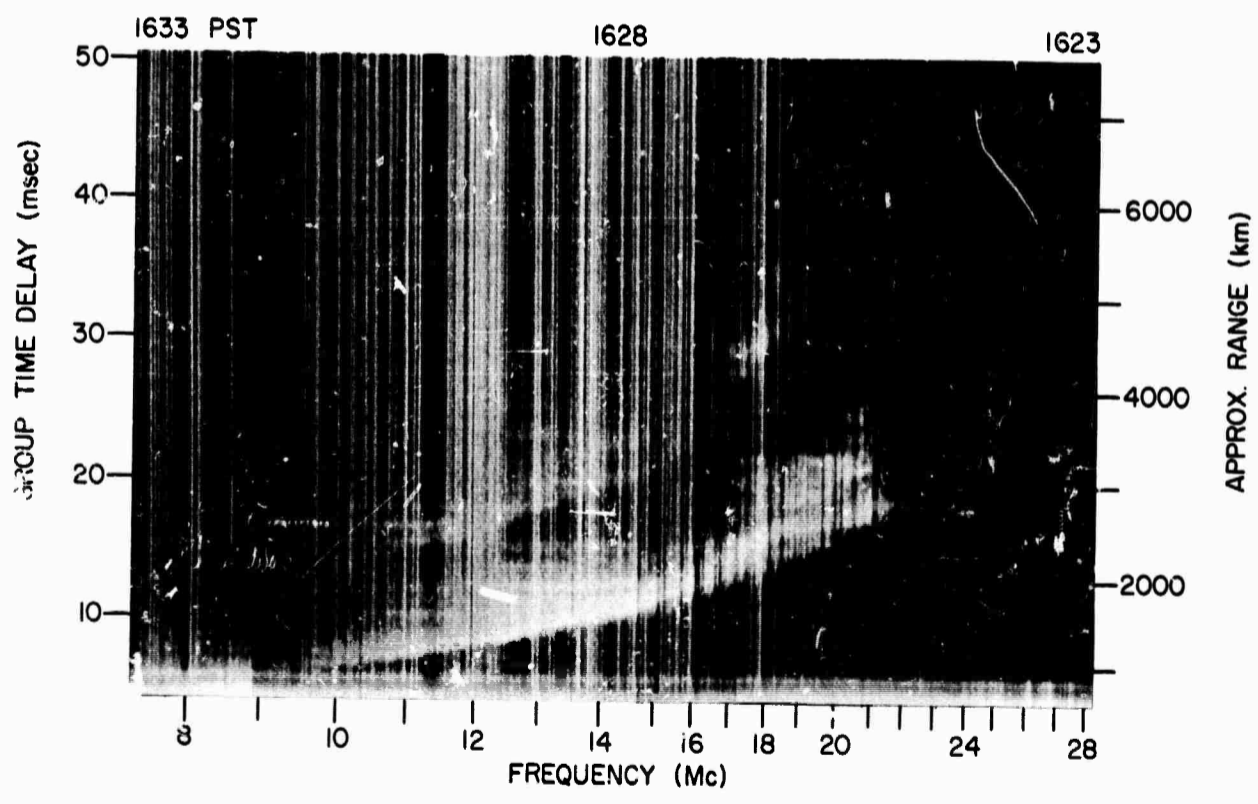

Z RECORD, 17 FEB 1965, 122° BEARING

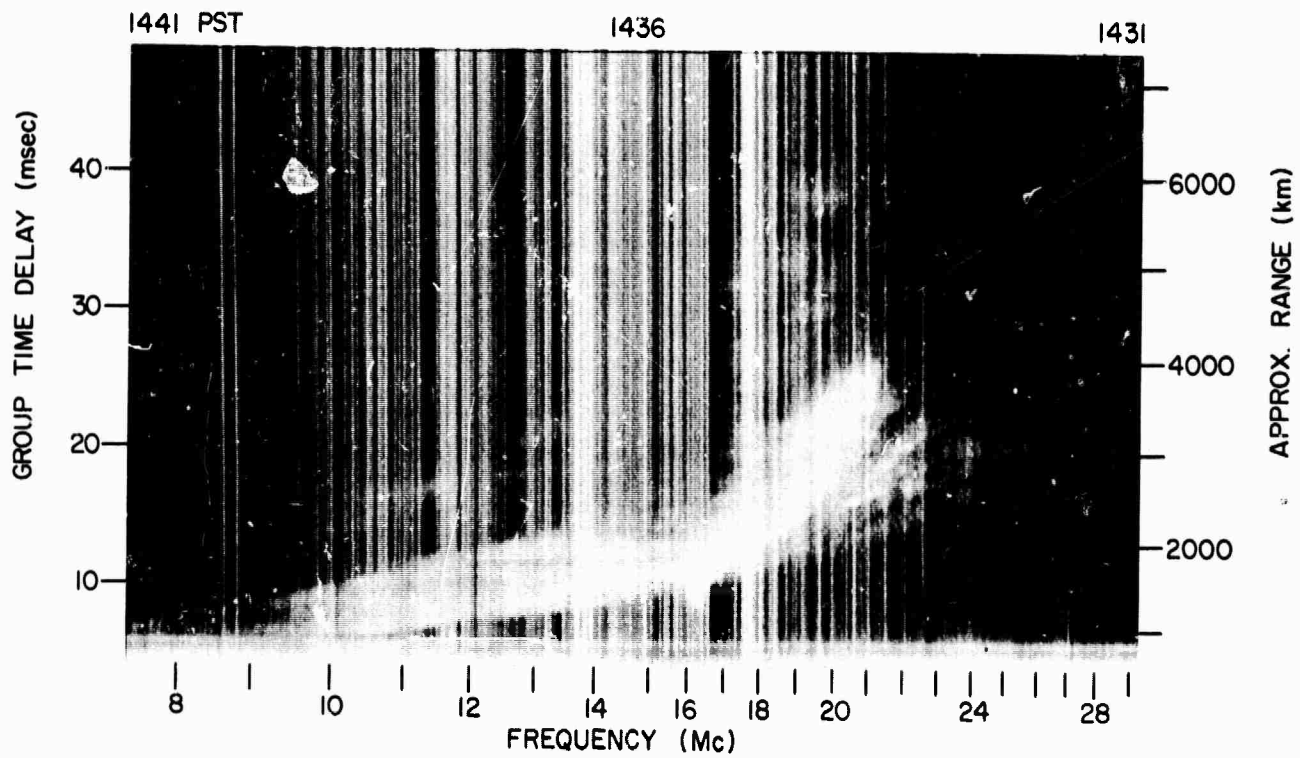
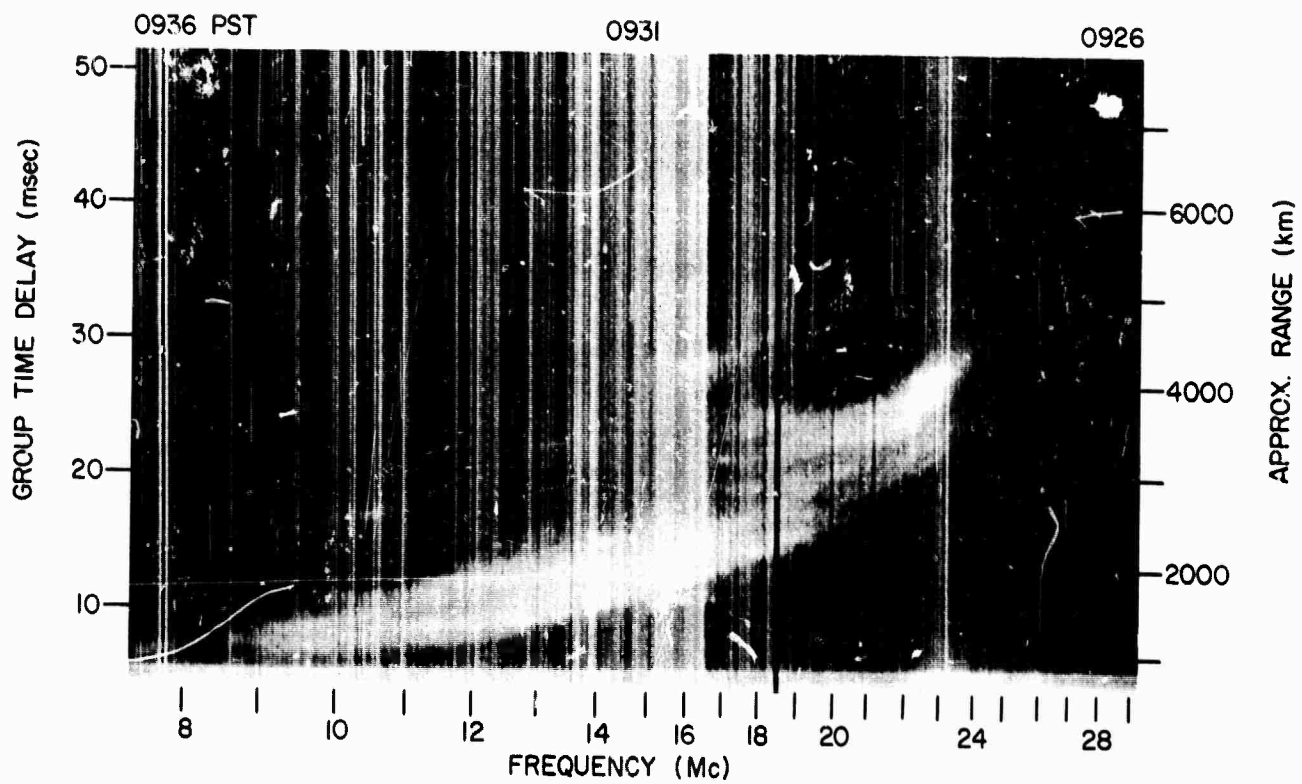

Z RECORDS, 18 FEB 1965, 122° BEARING



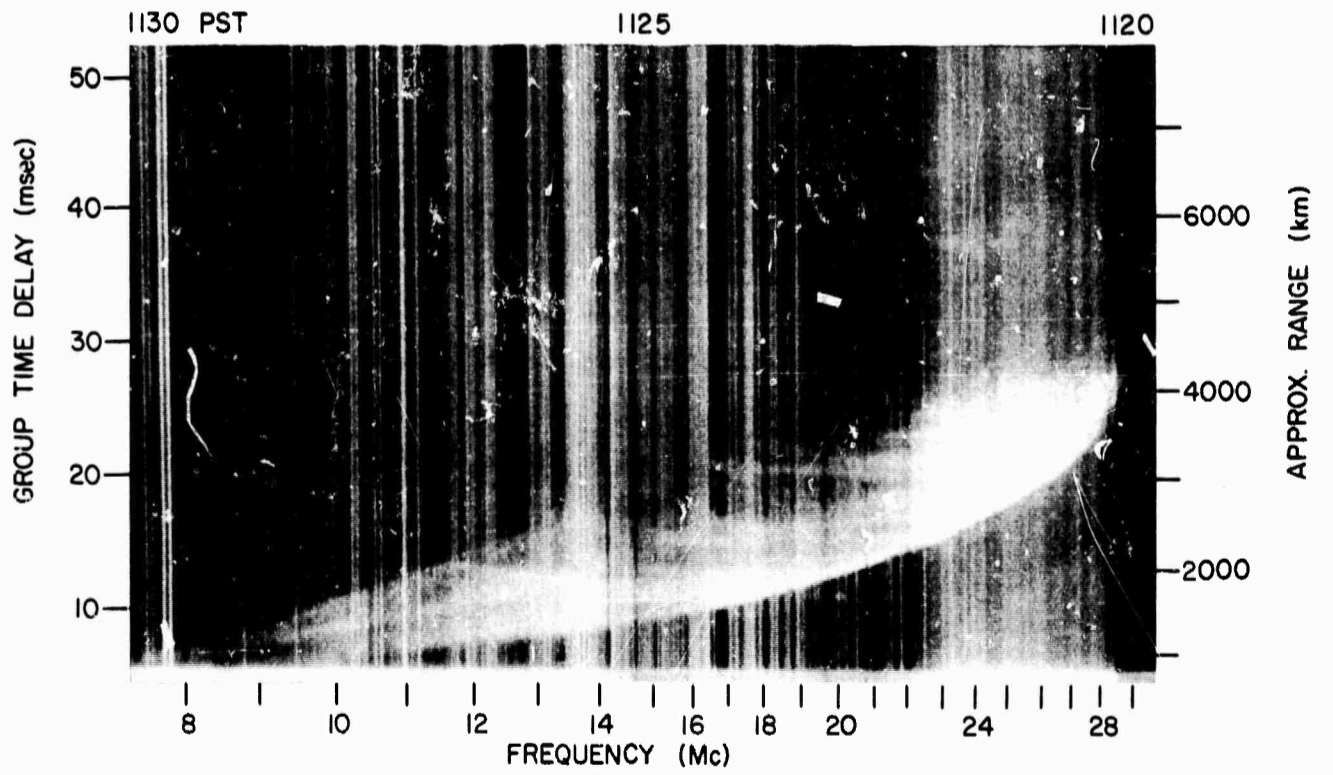
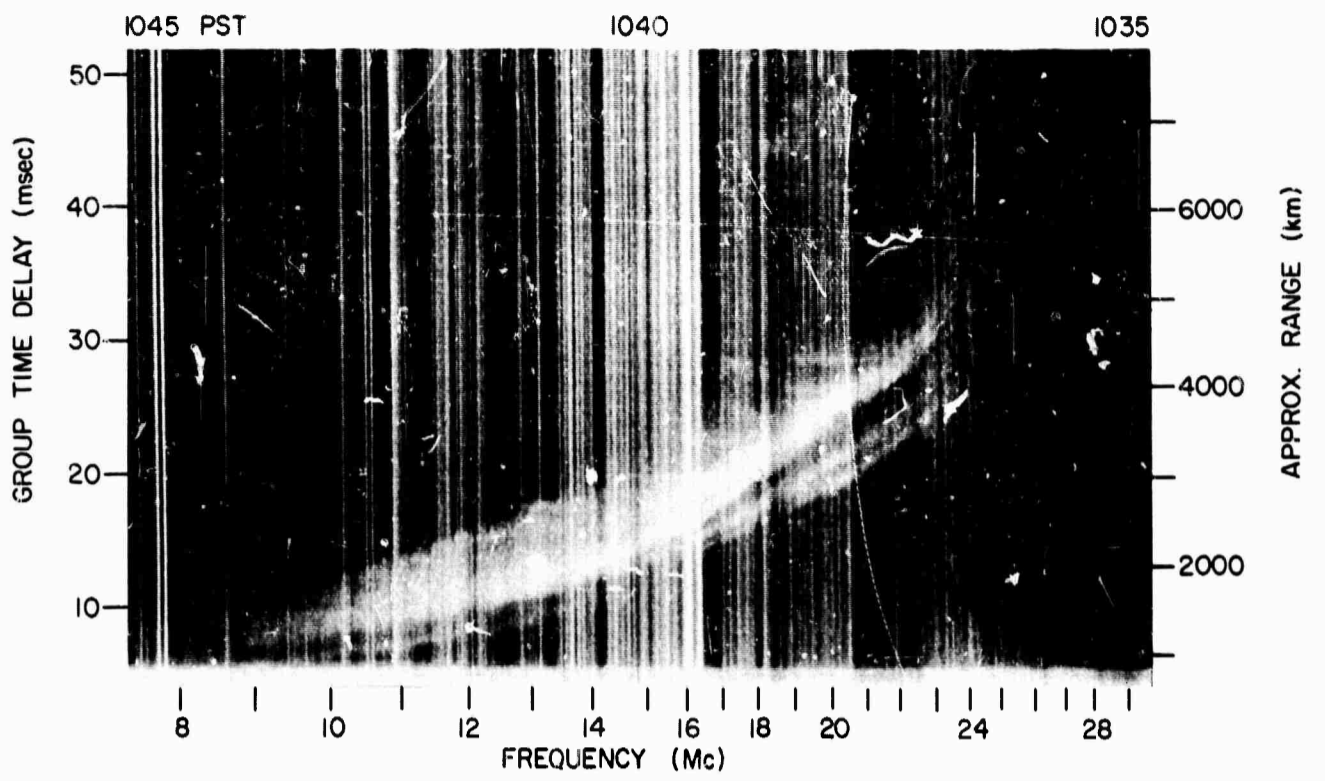
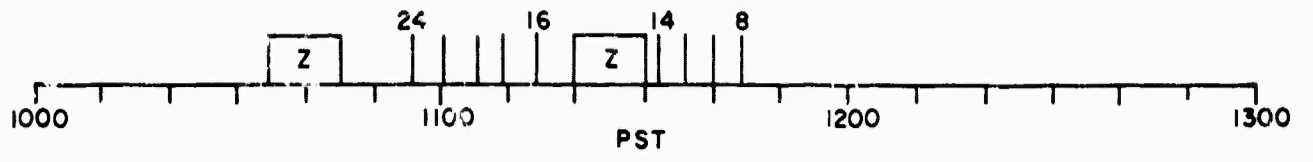

Z RECORDS, 23 FEB 1965, 122° BEARING

FREQ.  
TIME  
XMTD. POWER

FREQ.  
TIME  
XMTD. POWER

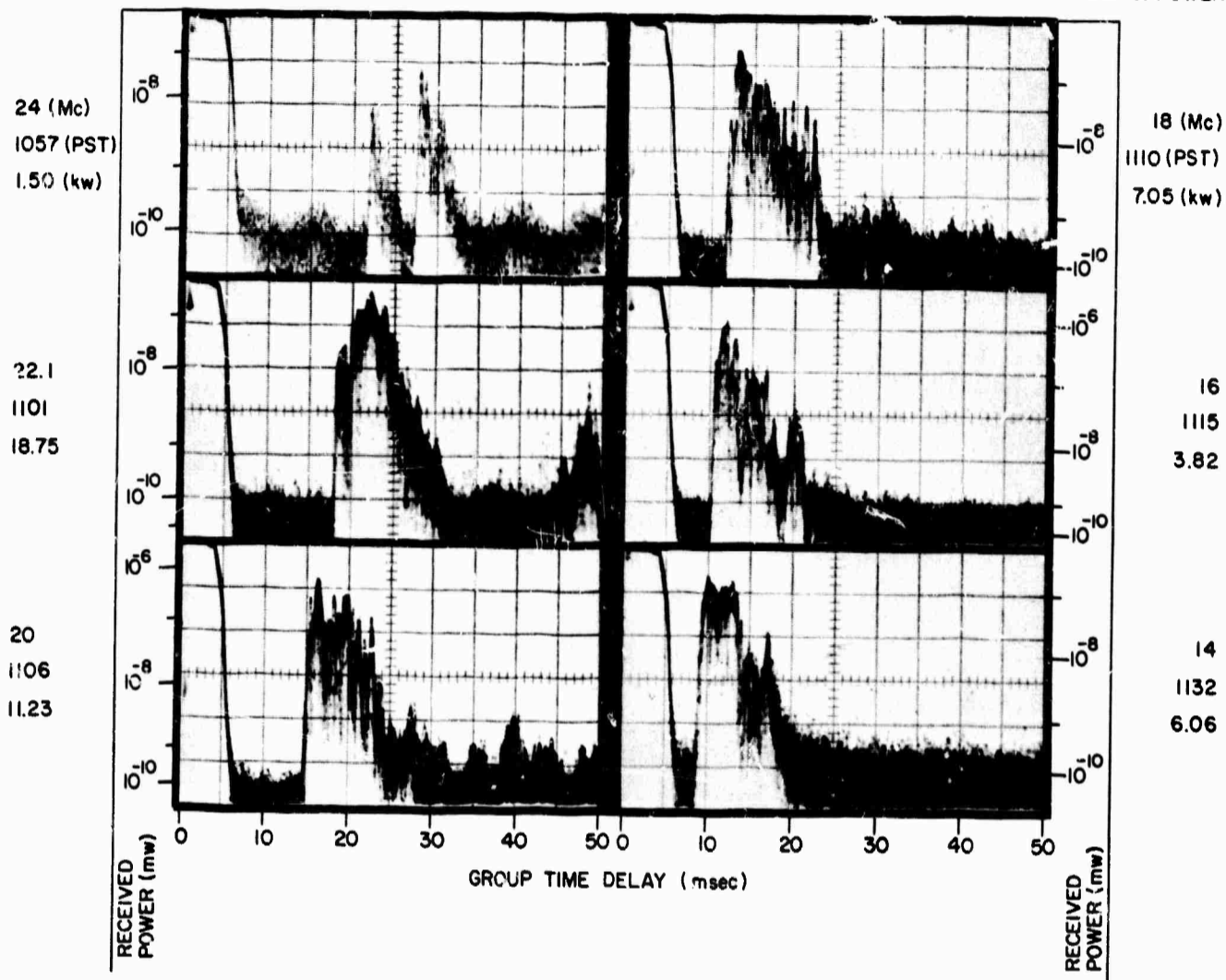

A RECORDS, 23 FEB 1965, 122° BEARING

FREQ.  
TIME  
XMTD. POWER

FREQ.  
TIME  
XMTD. POWER

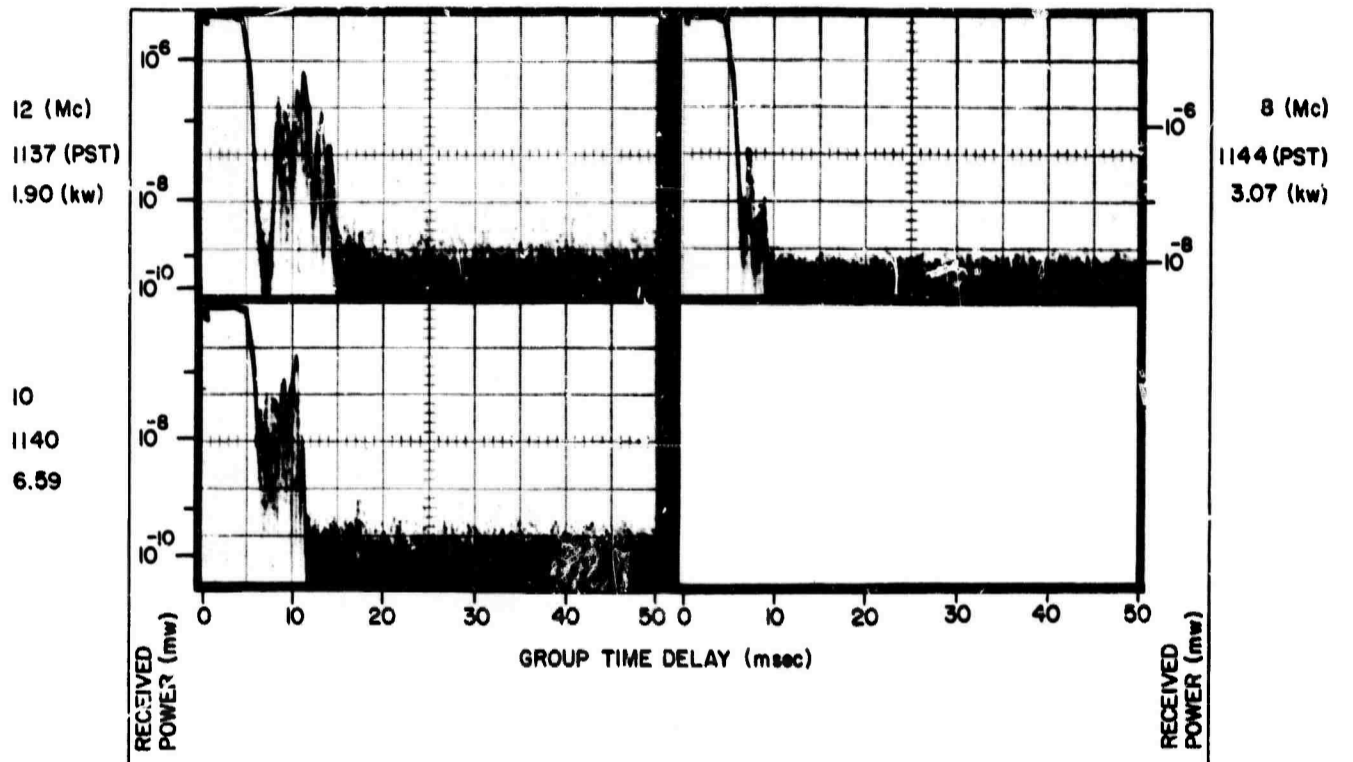

A RECORDS, 23 FEB 1965, 122° BEARING

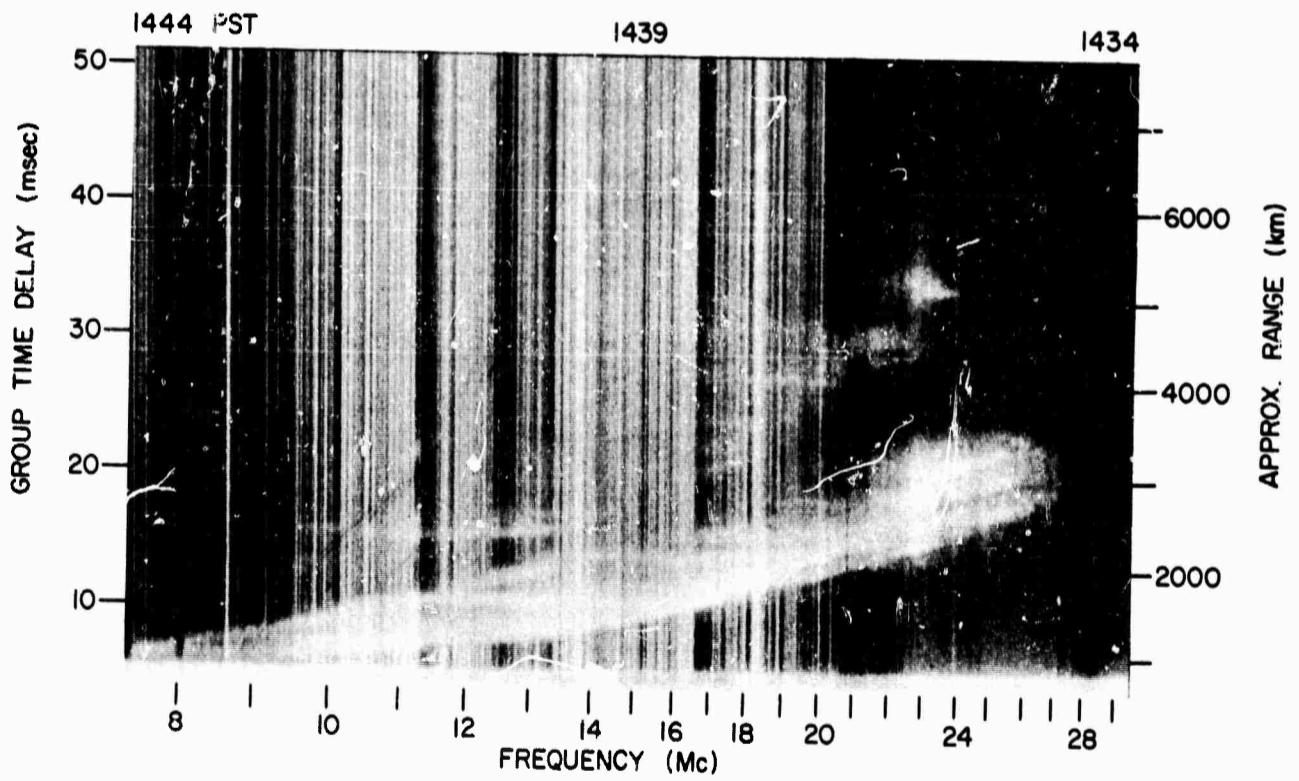
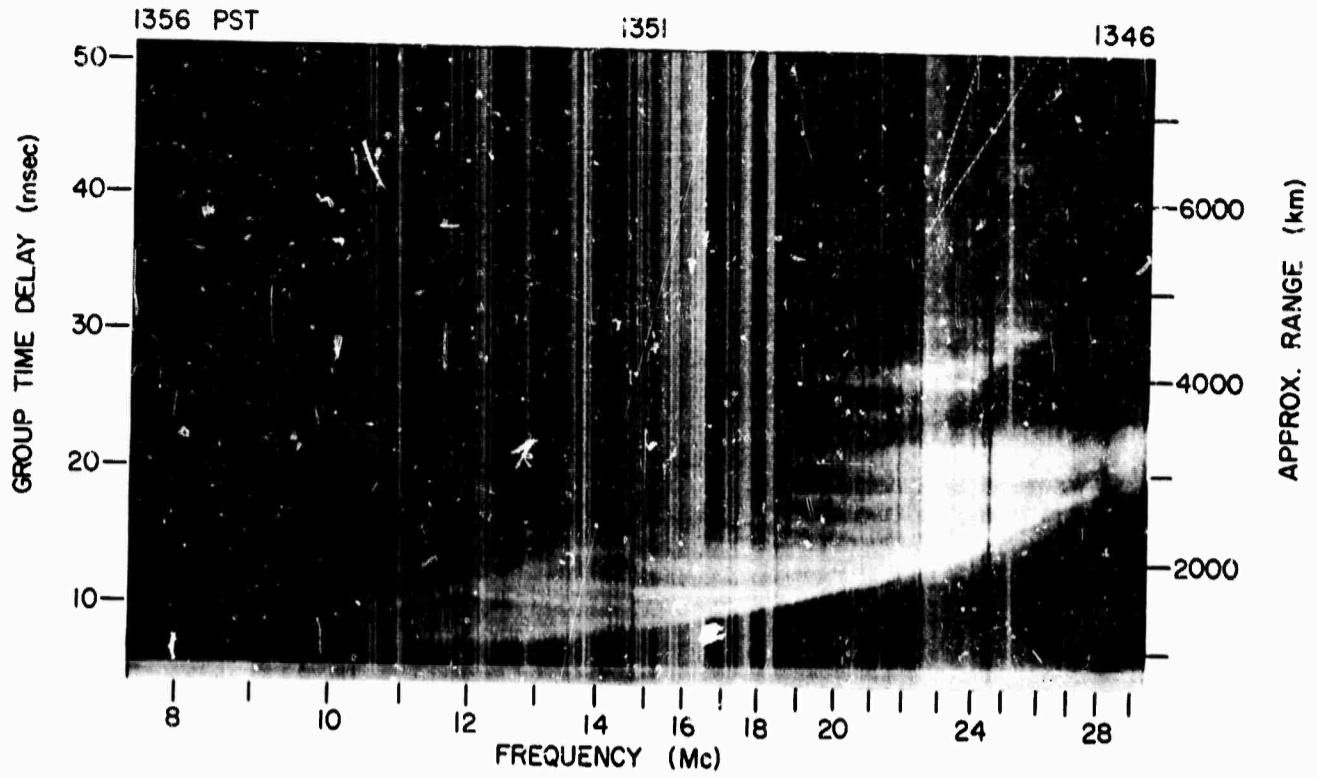
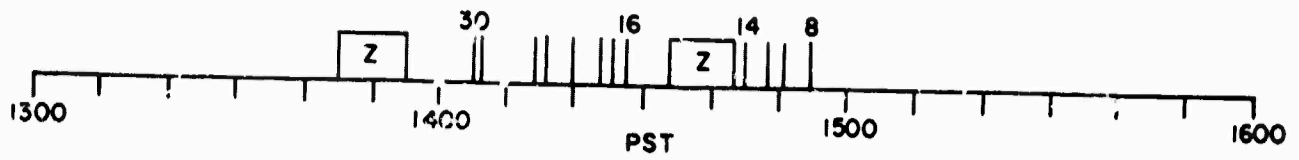

Z RECORDS, 23 FEB 1965, 122° BEARING

FREQ.  
TIME  
XMTD. POWER

FREQ.  
TIME  
XMTD. POWER

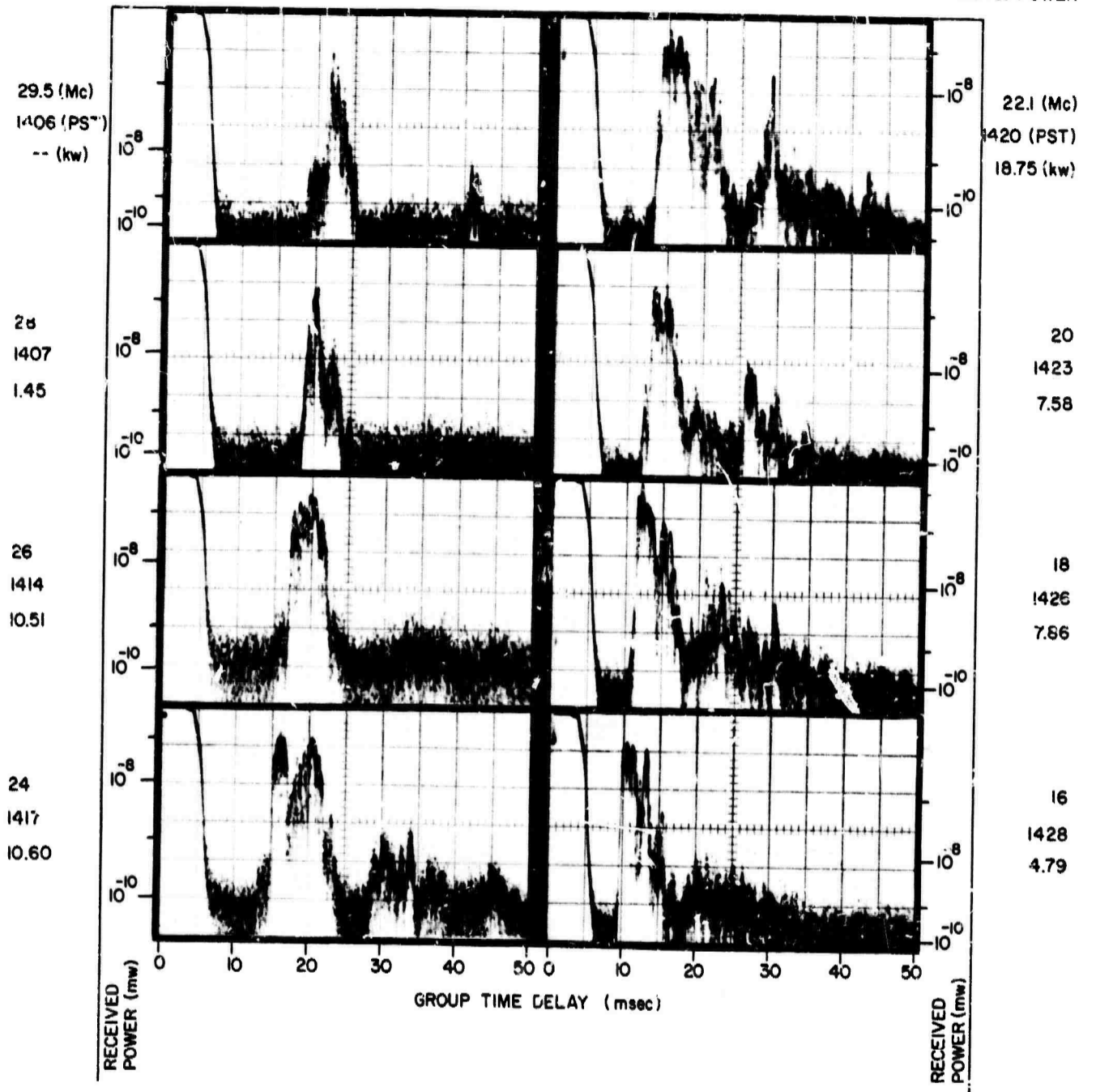

A RECORDS, 23 FEB 1965, 122° BEARING

FREQ.  
TIME  
XMTD. POWER

FREQ.  
TIME  
XMTD. POWER

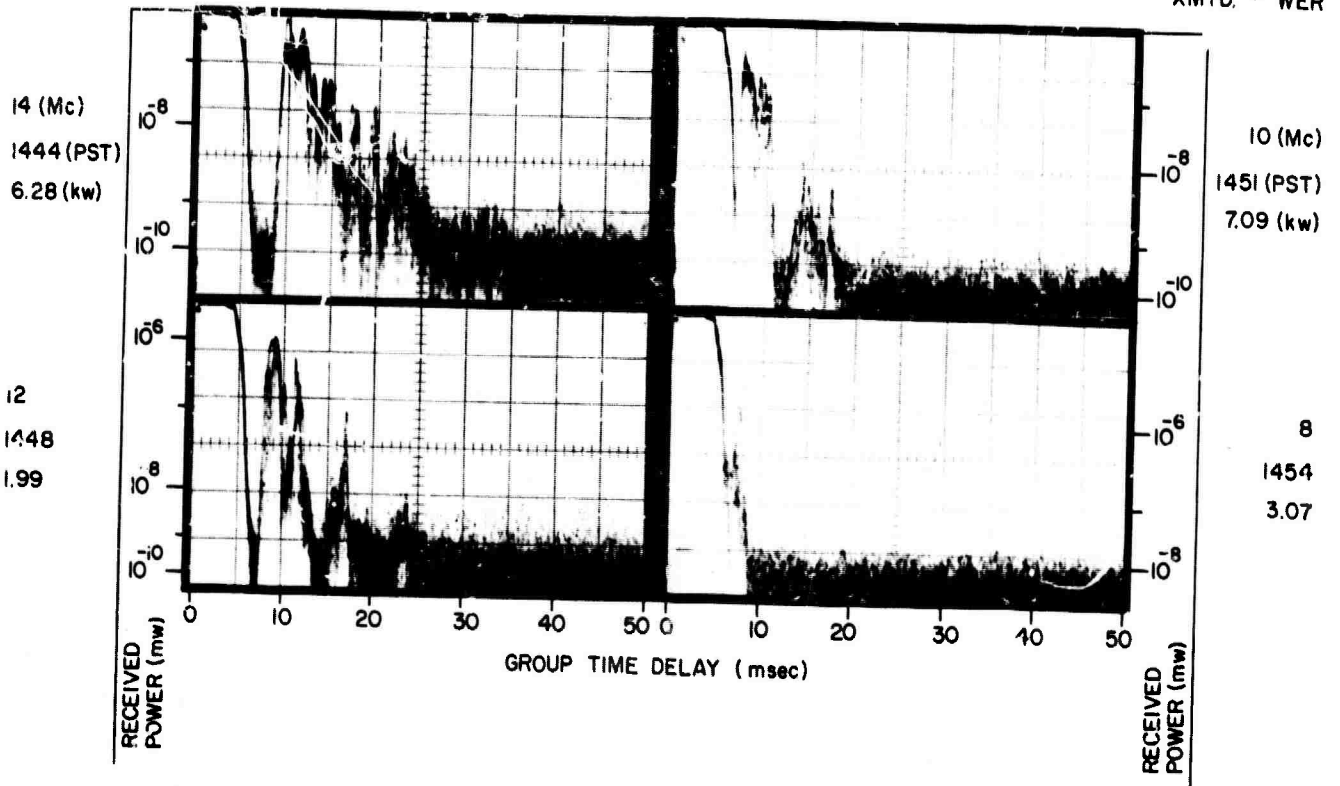

A RECORDS, 23 FEB 1965, 122° BEARING

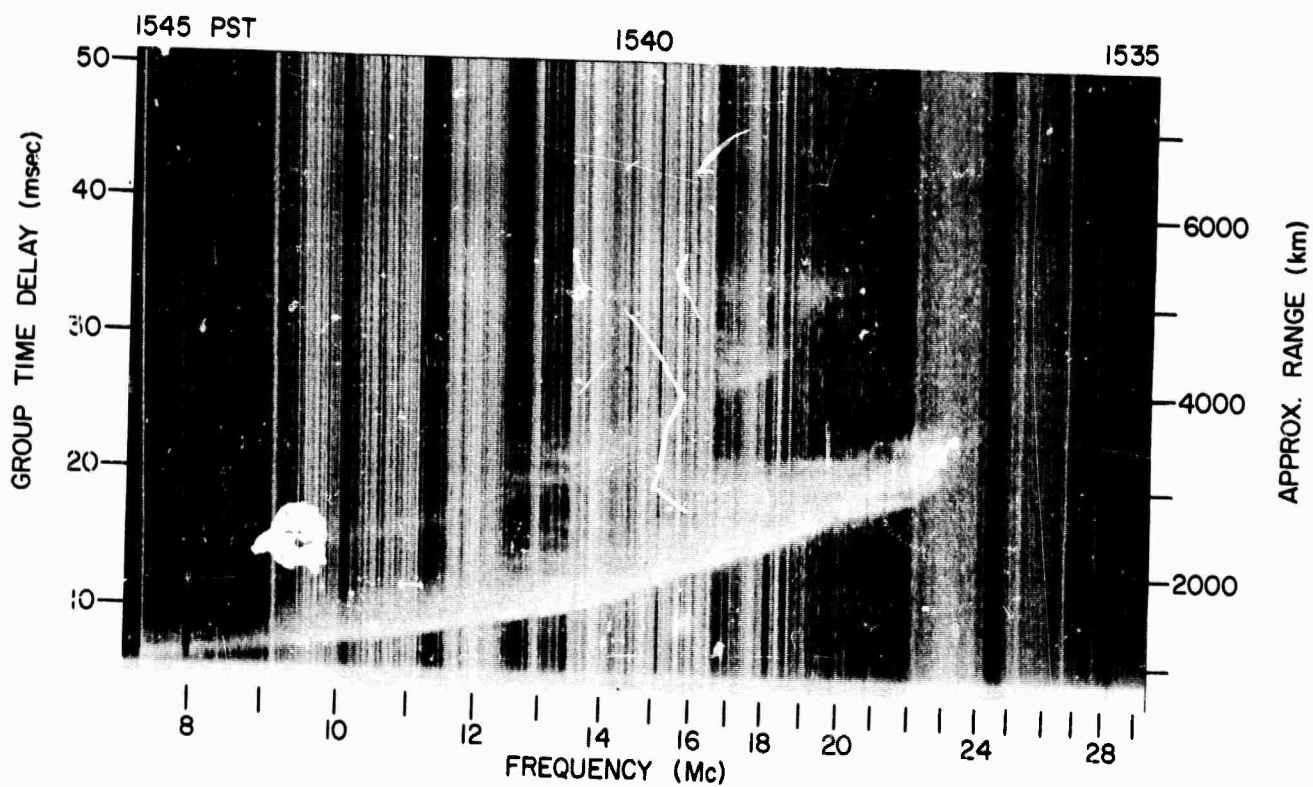
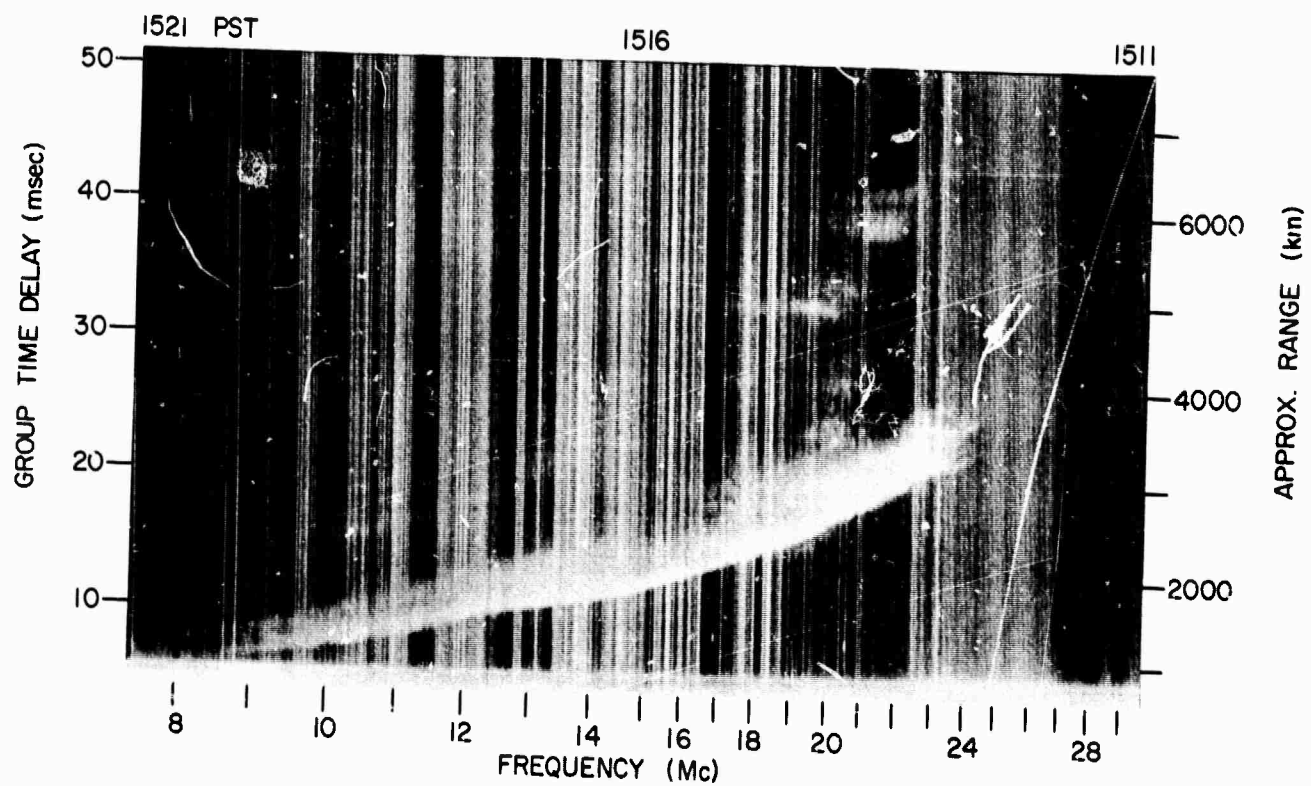

Z RECORDS, 24 FEB 1965, 122° BEARING

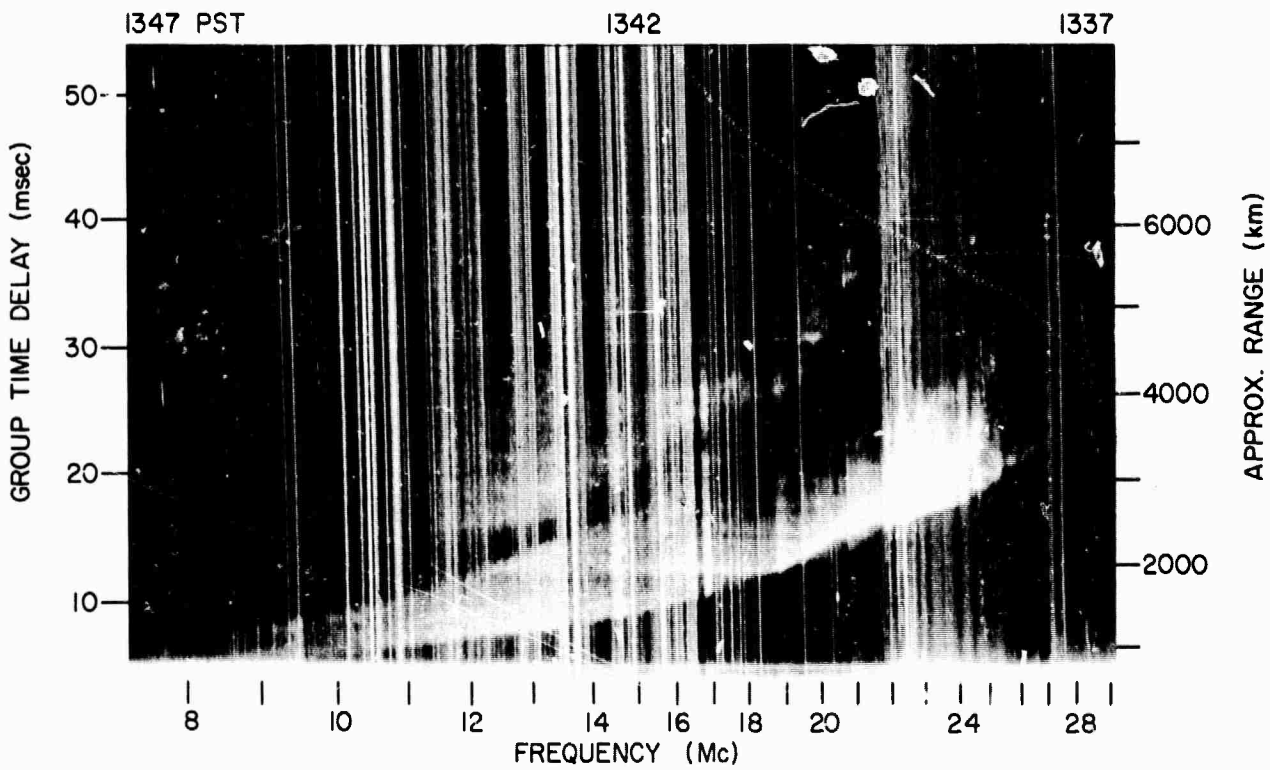
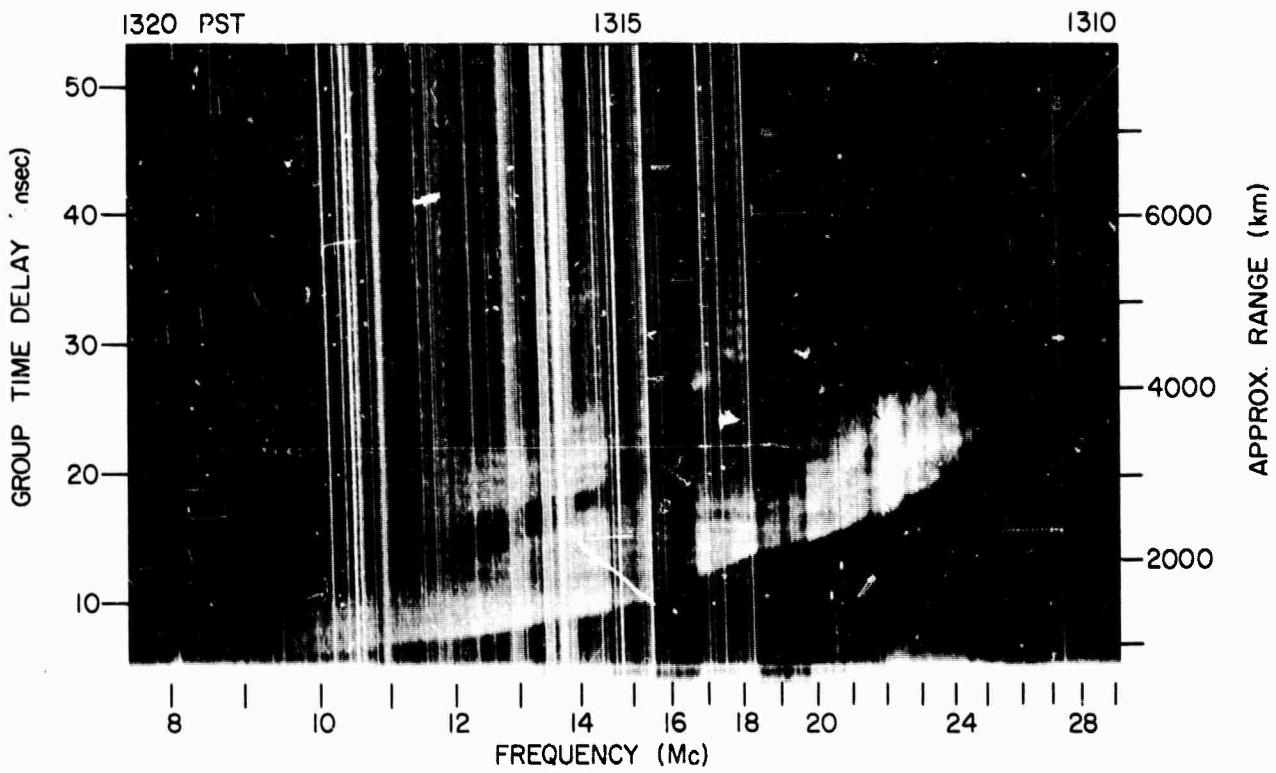
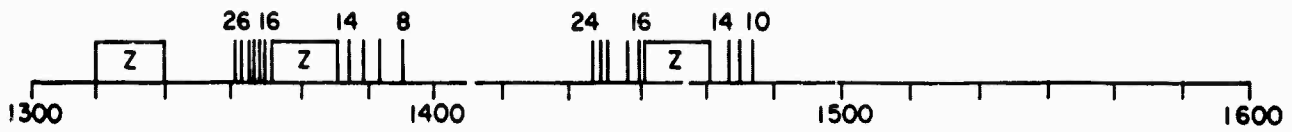

Z RECORDS, 8 MAR 1965, 302° BEARING

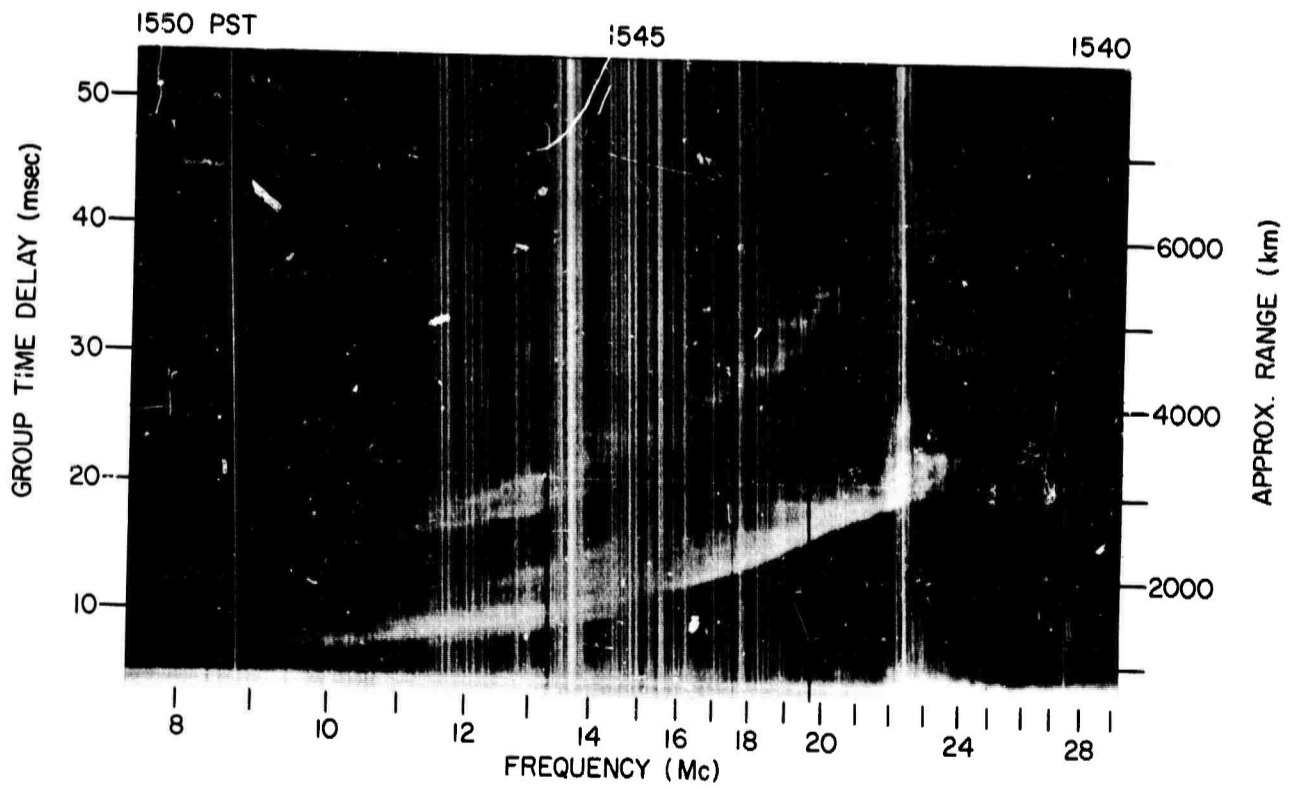
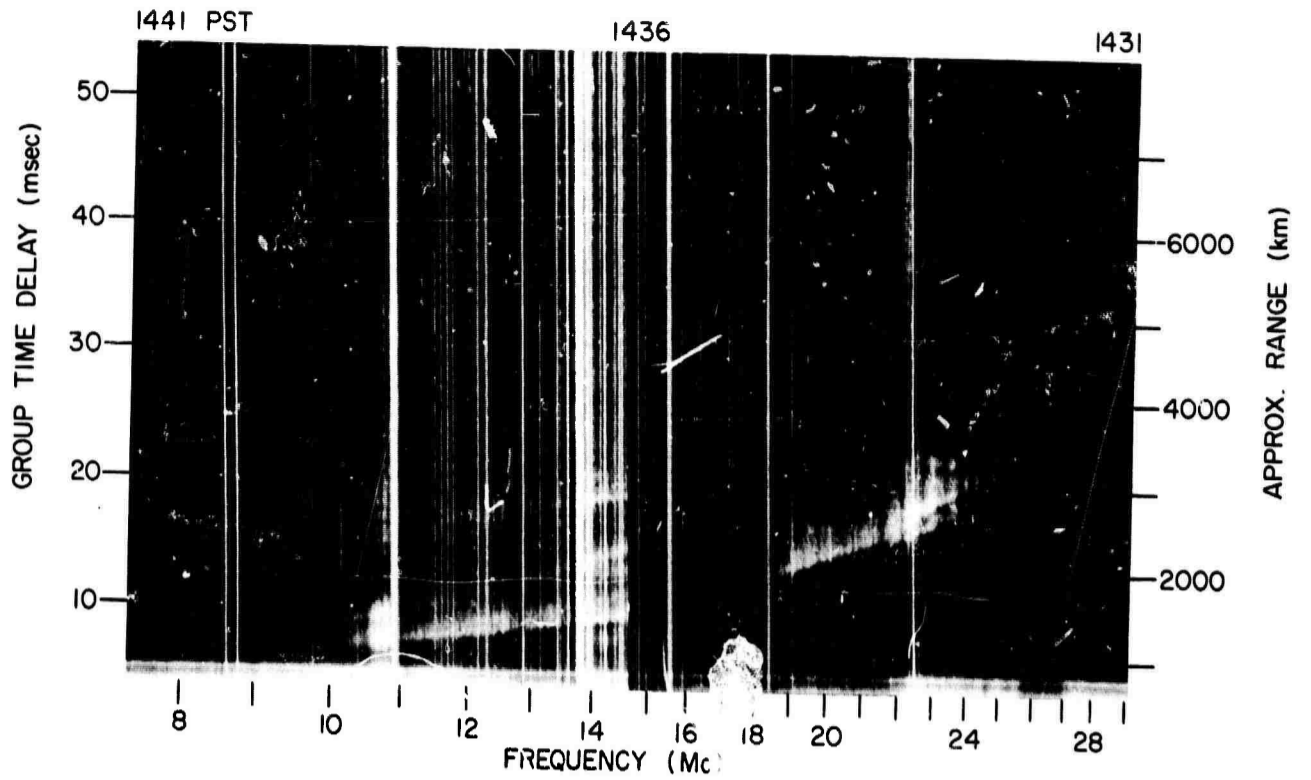

Z RECORDS, 8 MAR 1965, 302° BEARING

FREQ.  
TIME  
XMTD. POWER

FREQ.  
TIME  
XMTD. POWER

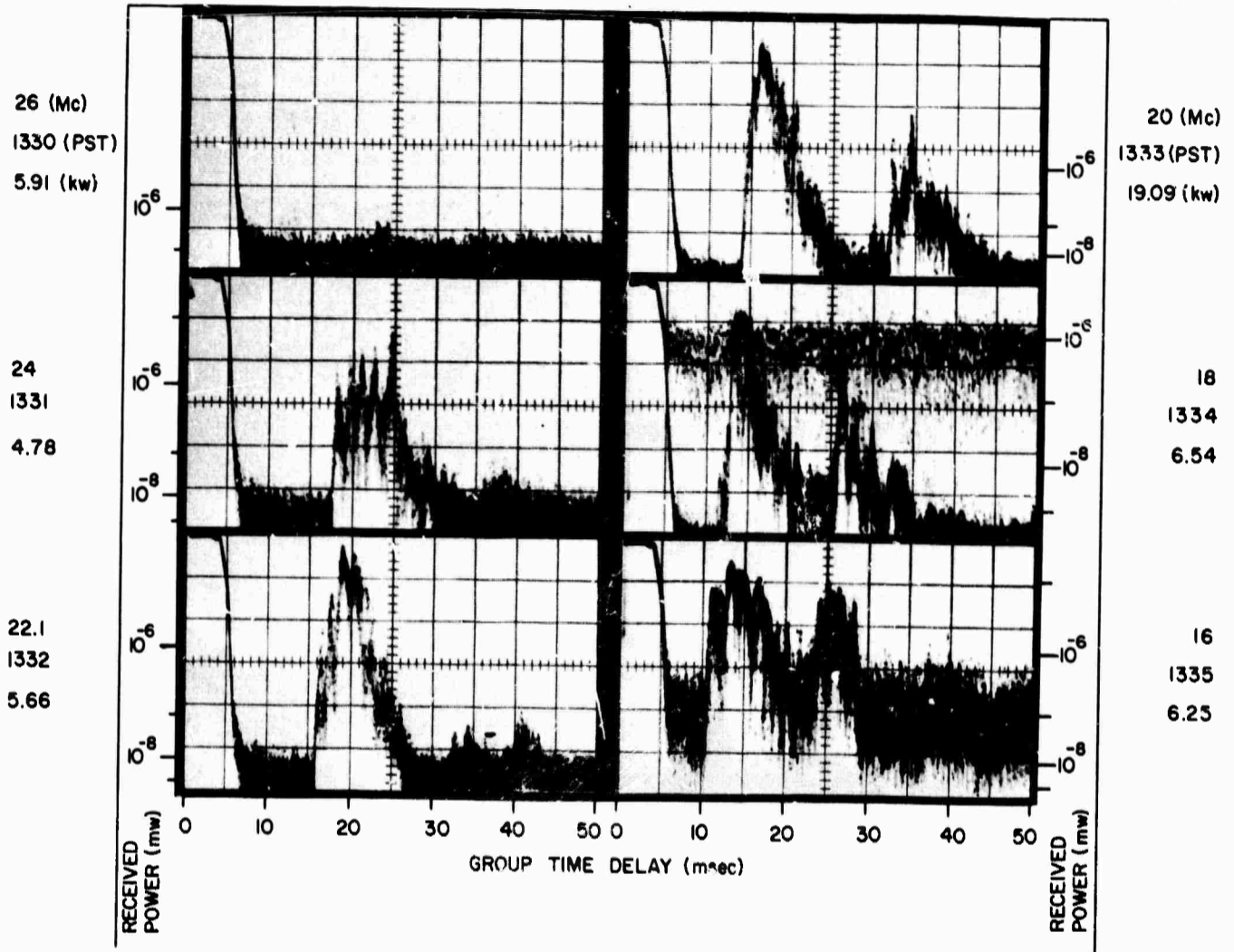

A RECORDS, 8 MAR 1965, 302° BEARING

FREQ.  
TIME  
XMTD. POWER

FREQ.  
TIME  
XMTD. POWER

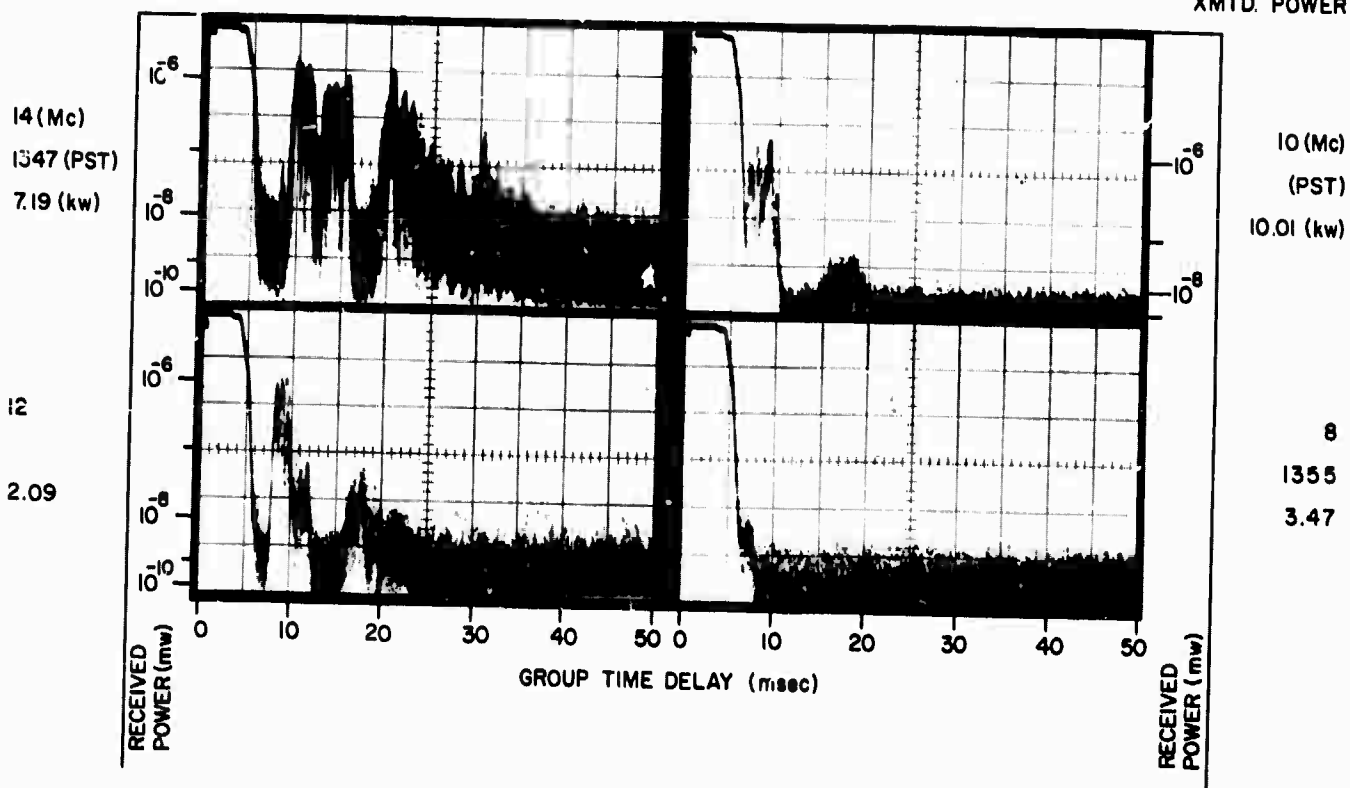

A RECORDS, 8 MAR 1965, 302° BEARING

FREQ.  
TIME  
XMTD. POWER

FREQ.  
TIME  
XMTD. POWER

24 (Mc)  
1423 (PST)  
5.12 (kw)

16 (Mc)  
1430 (PST)  
6.63 (kw)

22.1  
1424  
5.95

14  
1444  
7.67

20  
1425  
19.09

12  
1445  
2.09

18  
1428  
6.54

10  
1447  
9.15

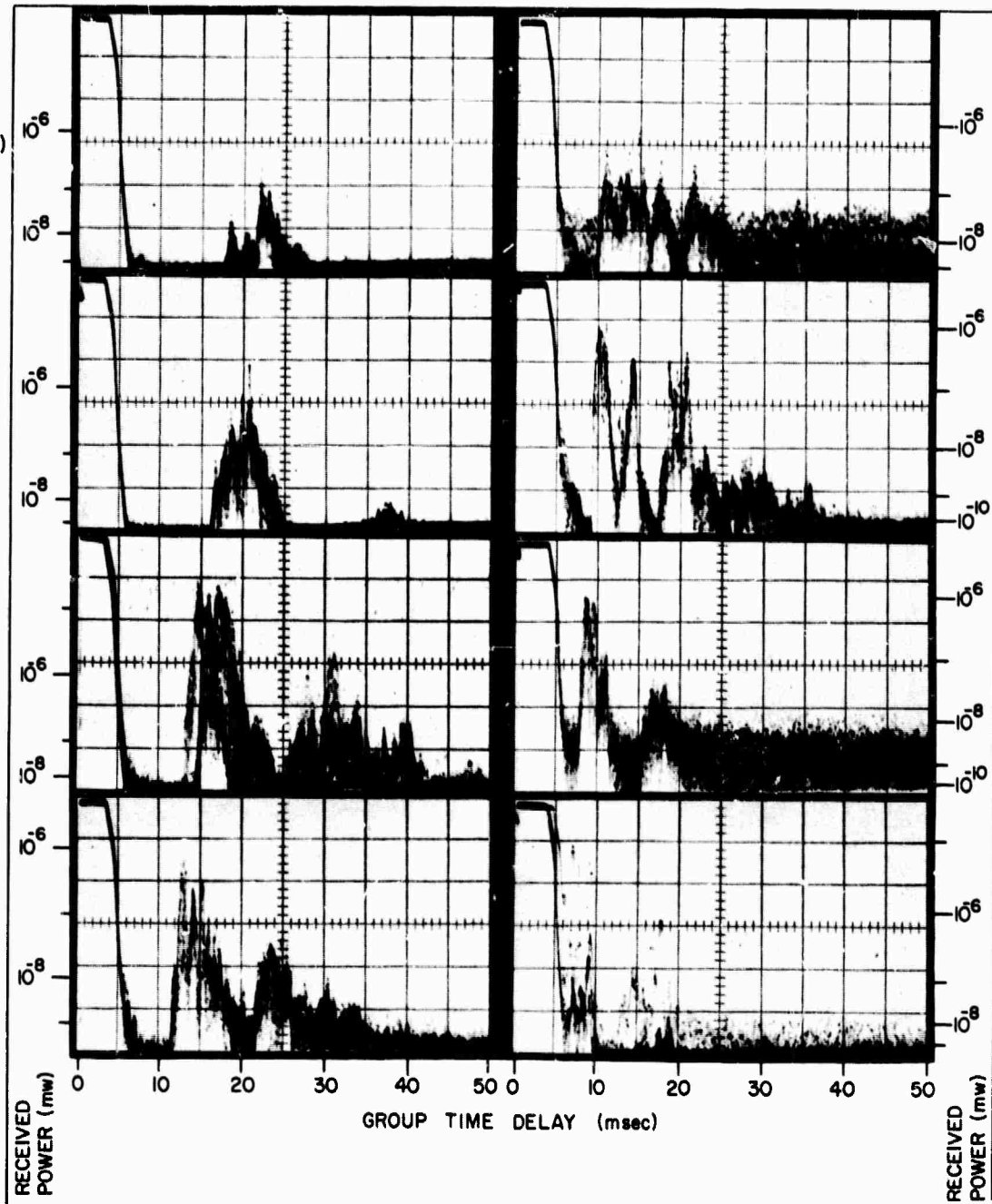

A RECORDS, 8 MAR 1965, 302° BEARING

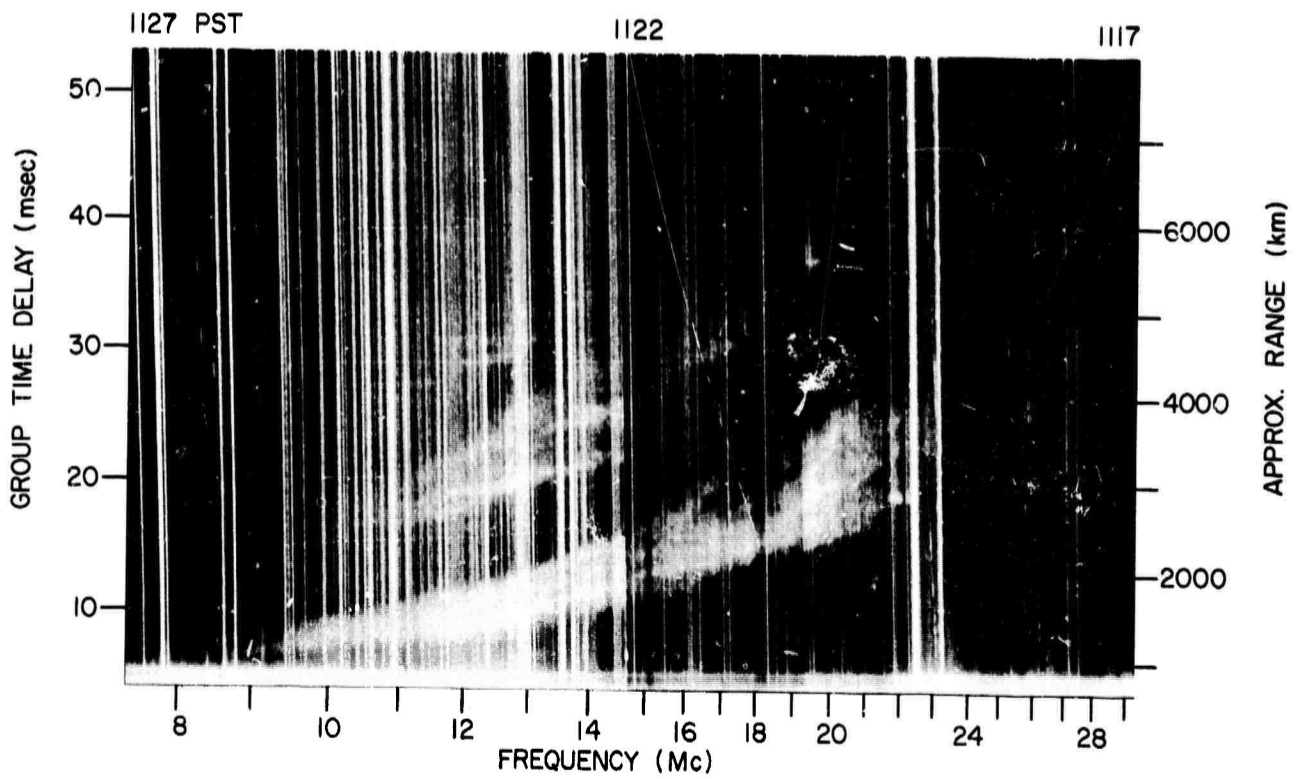
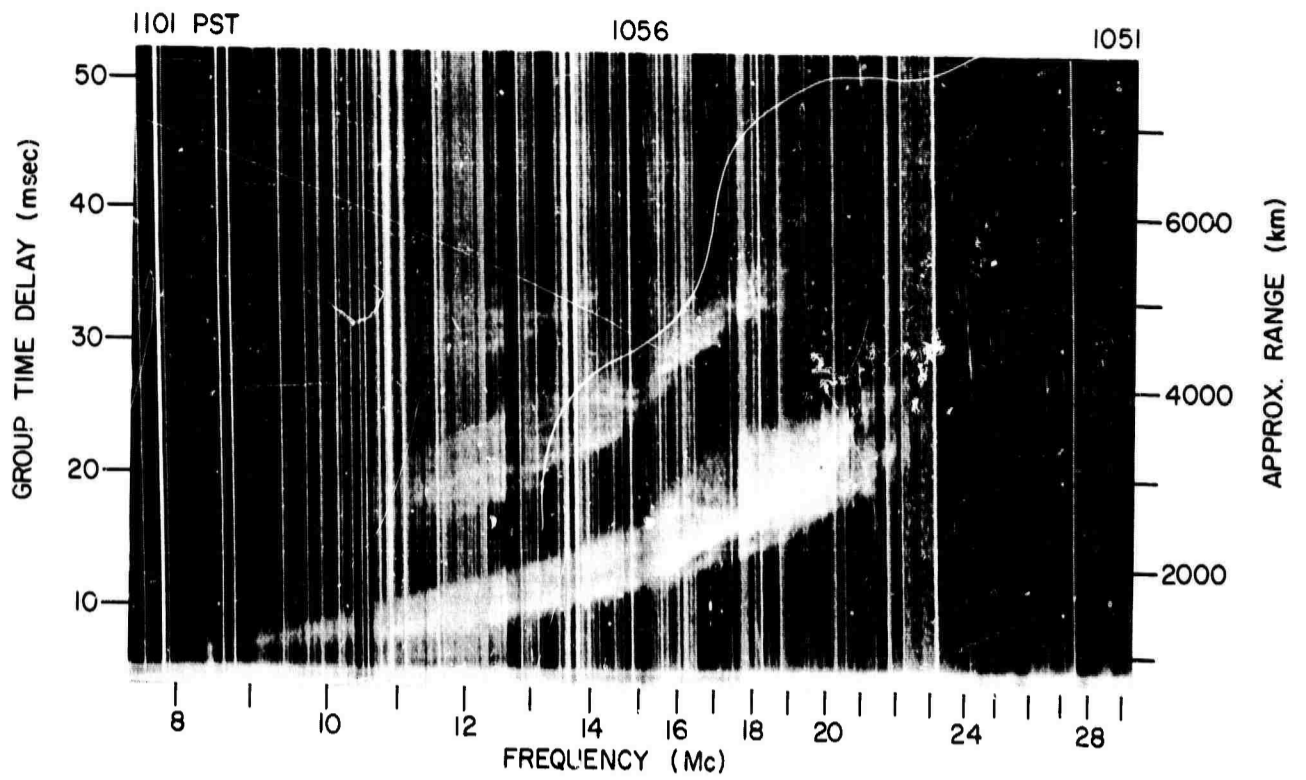
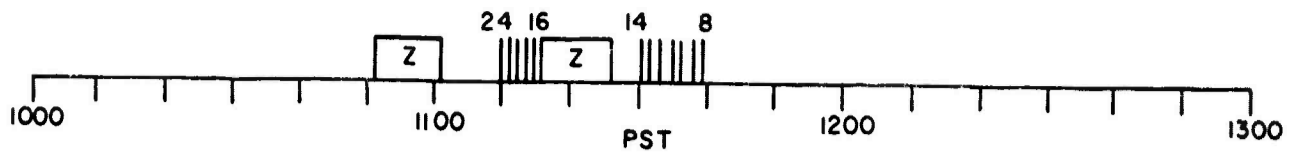

Z RECORDS, 9 MAR 1965, 302° BEARING

FREQ.  
TIME  
XMTD. POWER

FREQ.  
TIME  
XMTD. POWER

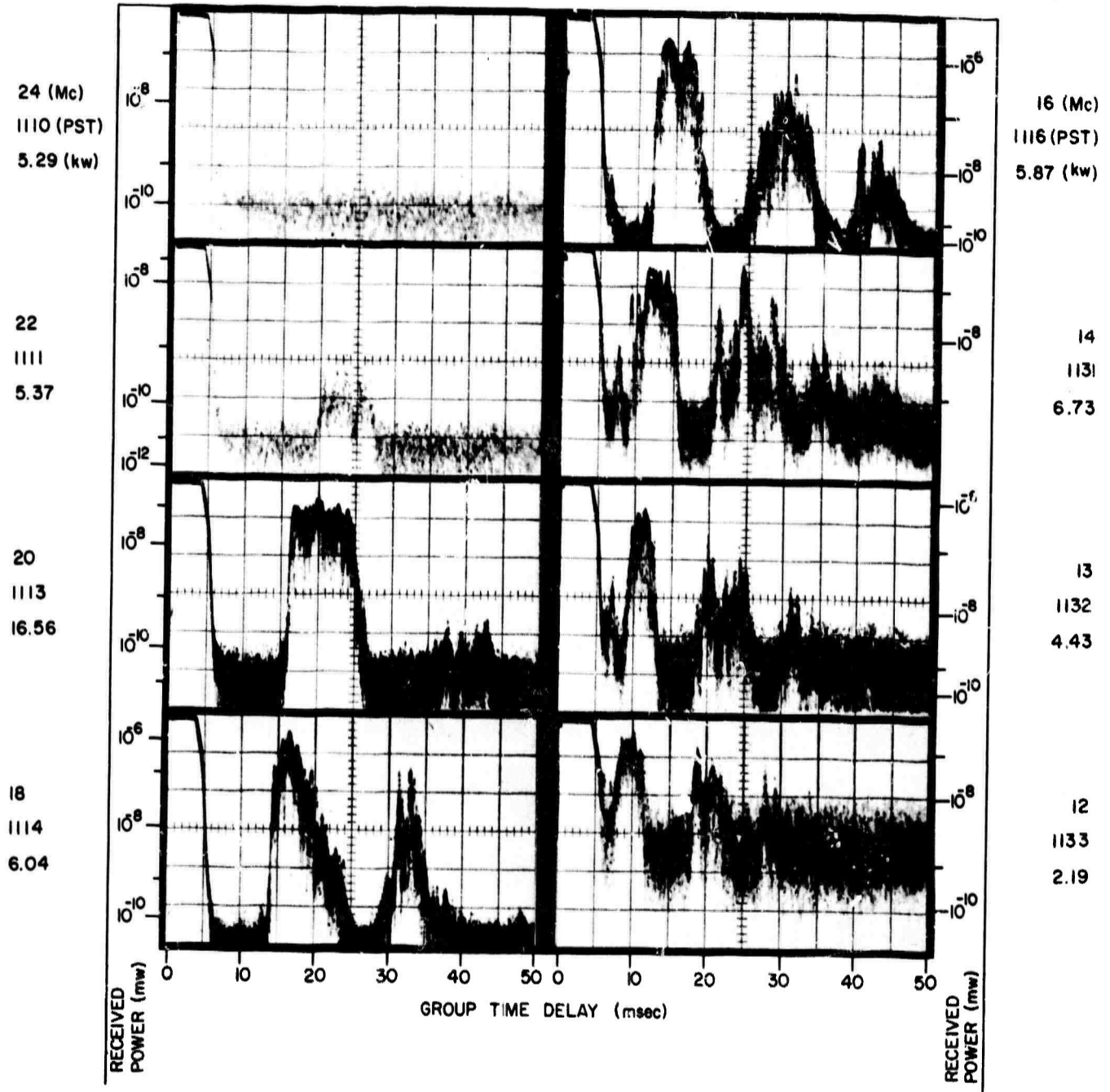

A RECORDS, 9 MAR 1965, 302° BEARING

FREQ.  
TIME  
XMTD. POWER

FREQ.  
TIME  
XMTD. POWER

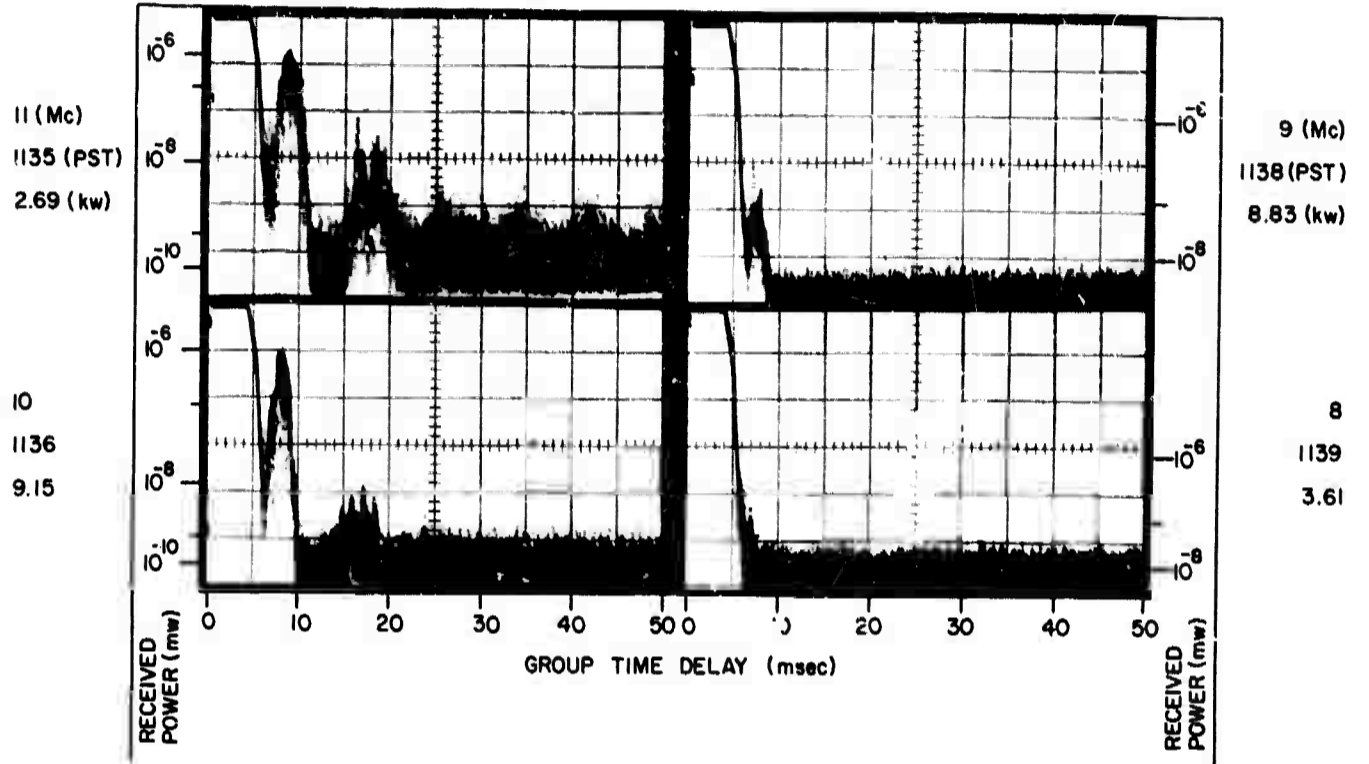

A RECORDS, 9 MAR 1965, 302° BEARING

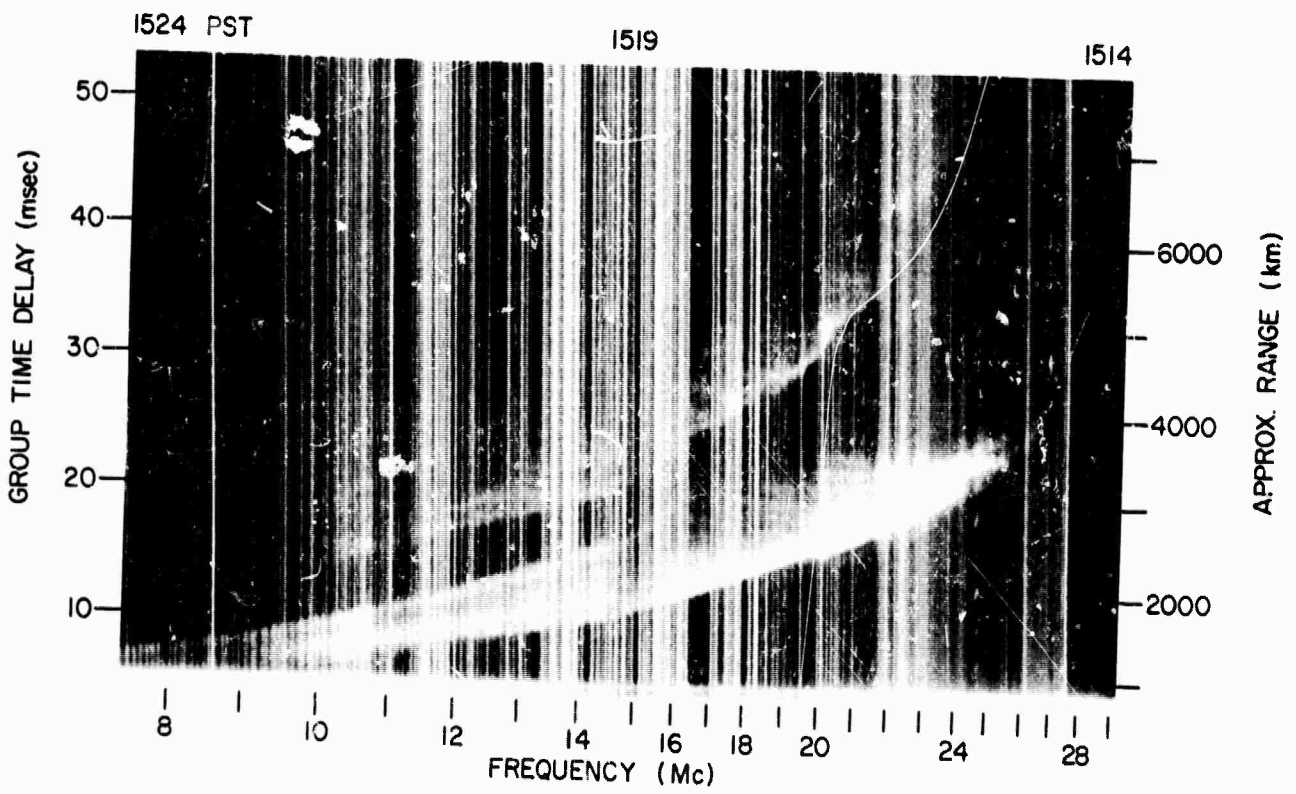
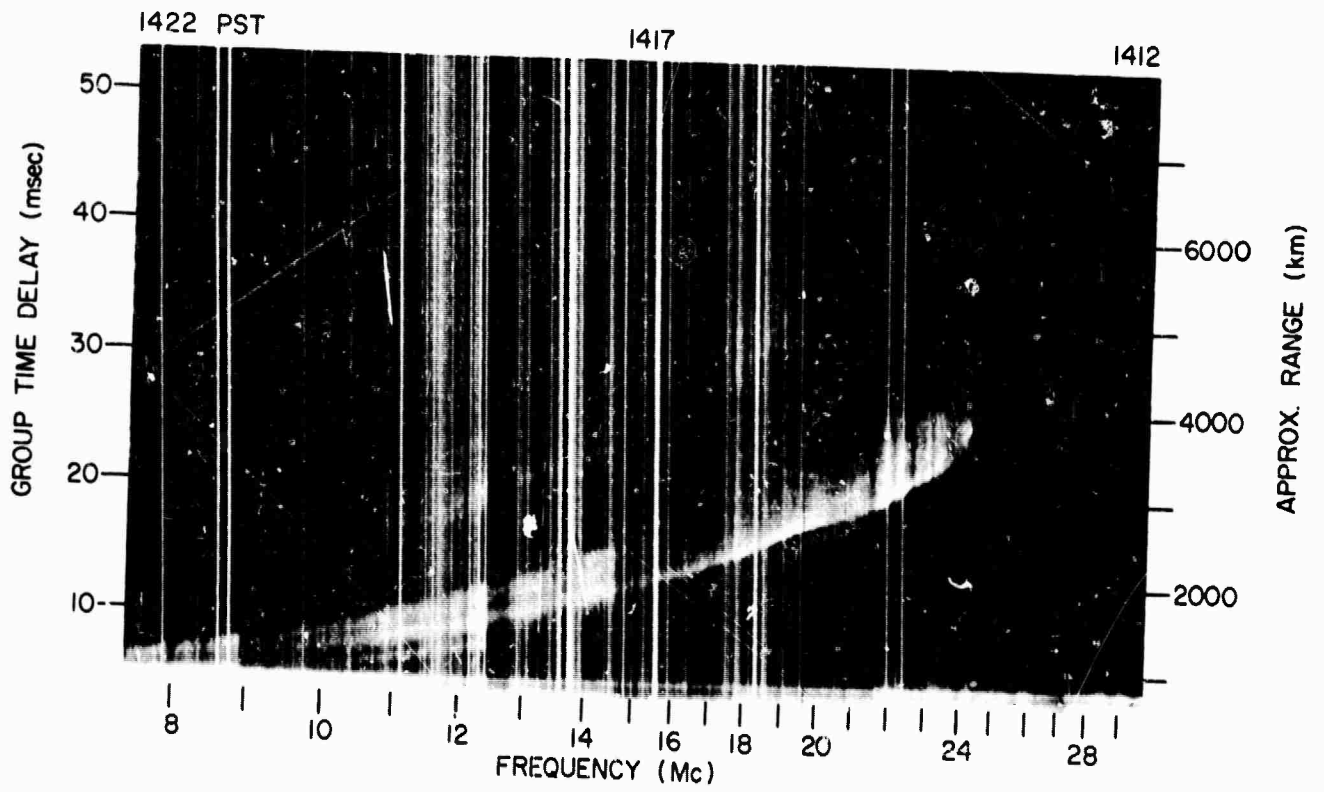
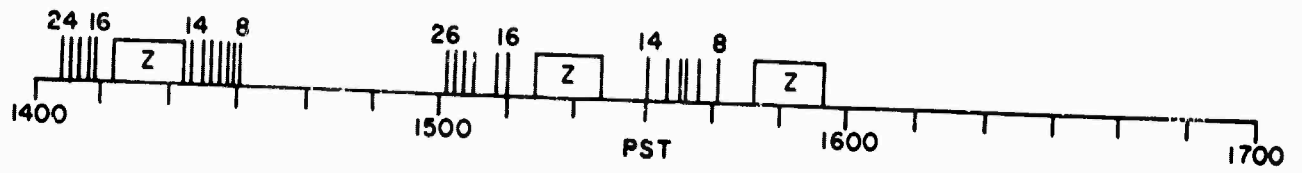

Z RECORDS, 9 MAR 1965, 302° BEARING

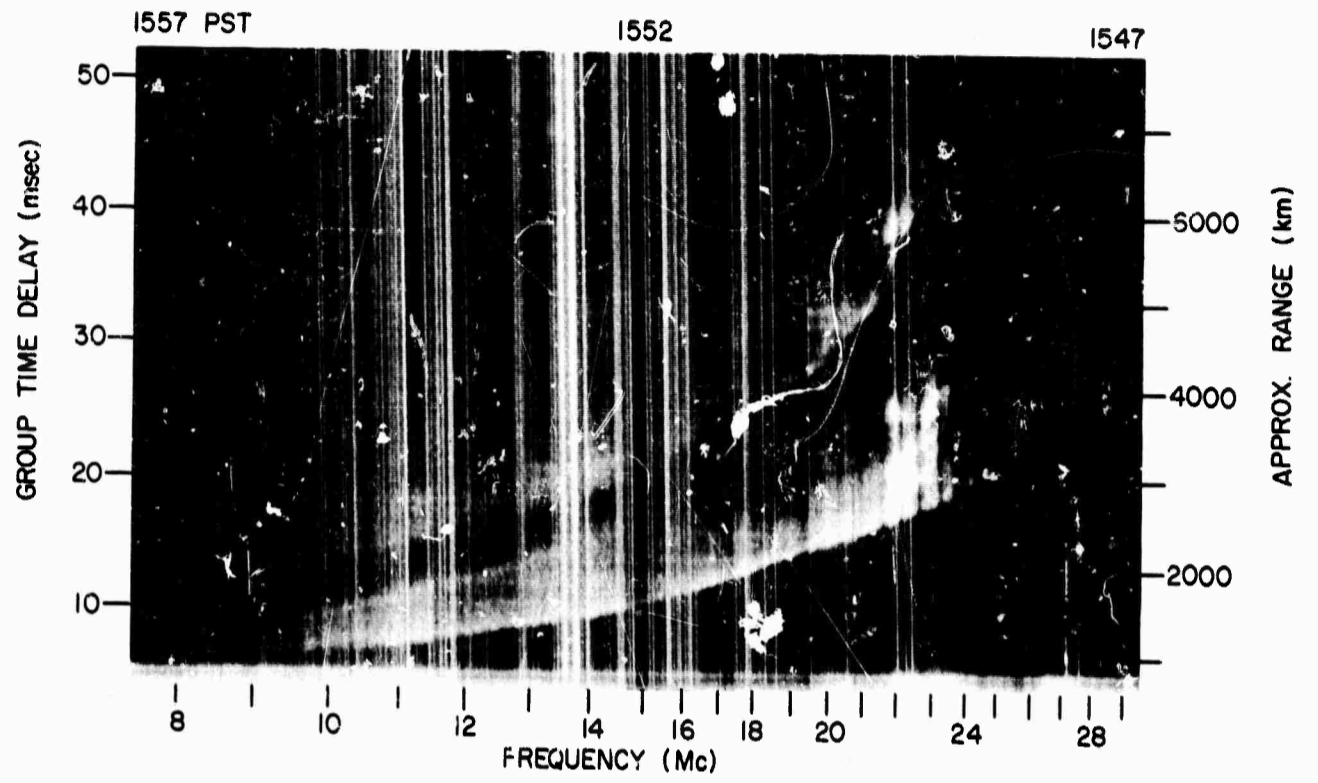

RECORD, 9 MAR 1965, 302° BEARING

FREQ.  
TIME  
XMTD. POWER

FREQ.  
TIME  
XMTD. POWER

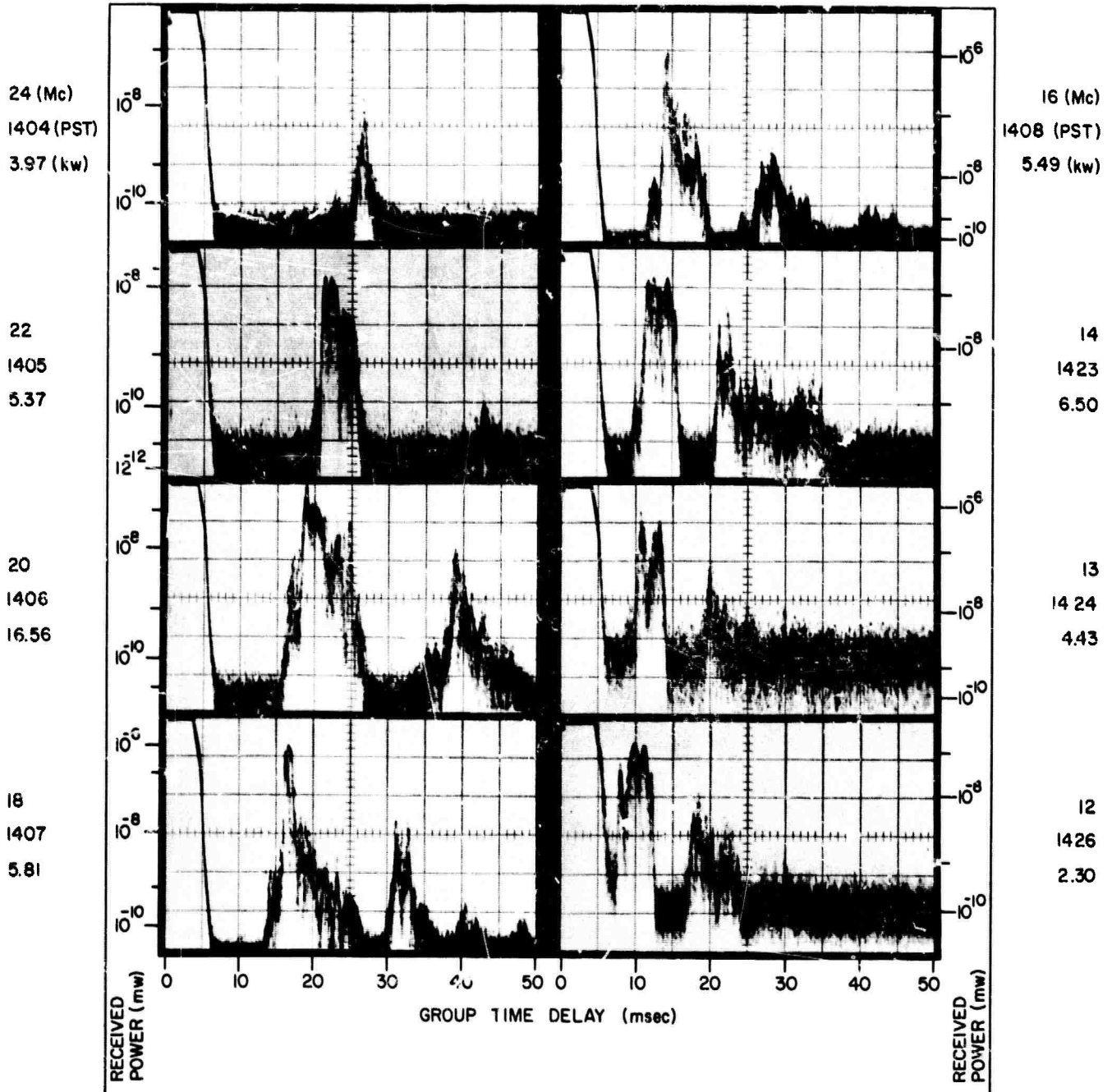

A RECORDS, 9 MAR 1965, 302° BEARING

FREQ.  
TIME  
XMTD. POWER

FREQ.  
TIME  
XMTD. POWER

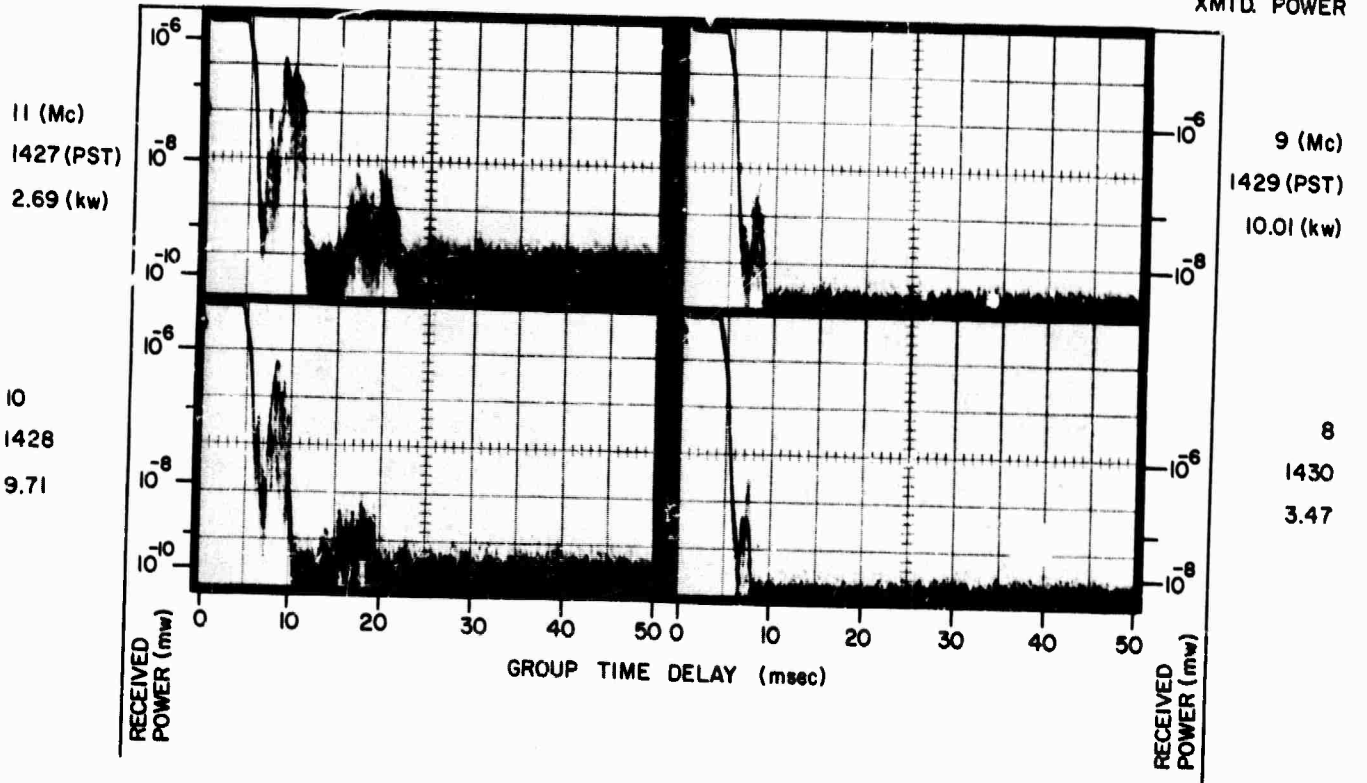

A RECORDS, 9 MAR 1965, 302° BEARING

FREQ.  
TIME  
XMTD. POWER

FREQ.  
TIME  
XMTD. POWER

26 (Mc)  
1502 (PST)  
5.61 (kw)

18 (Mc)  
1509 (PST)  
5.57 (kw)

24  
1503  
3.97

16  
1511  
5.49

22  
1504  
5.09

14  
1531  
6.50

20  
1506  
16.08

13  
1533  
4.43

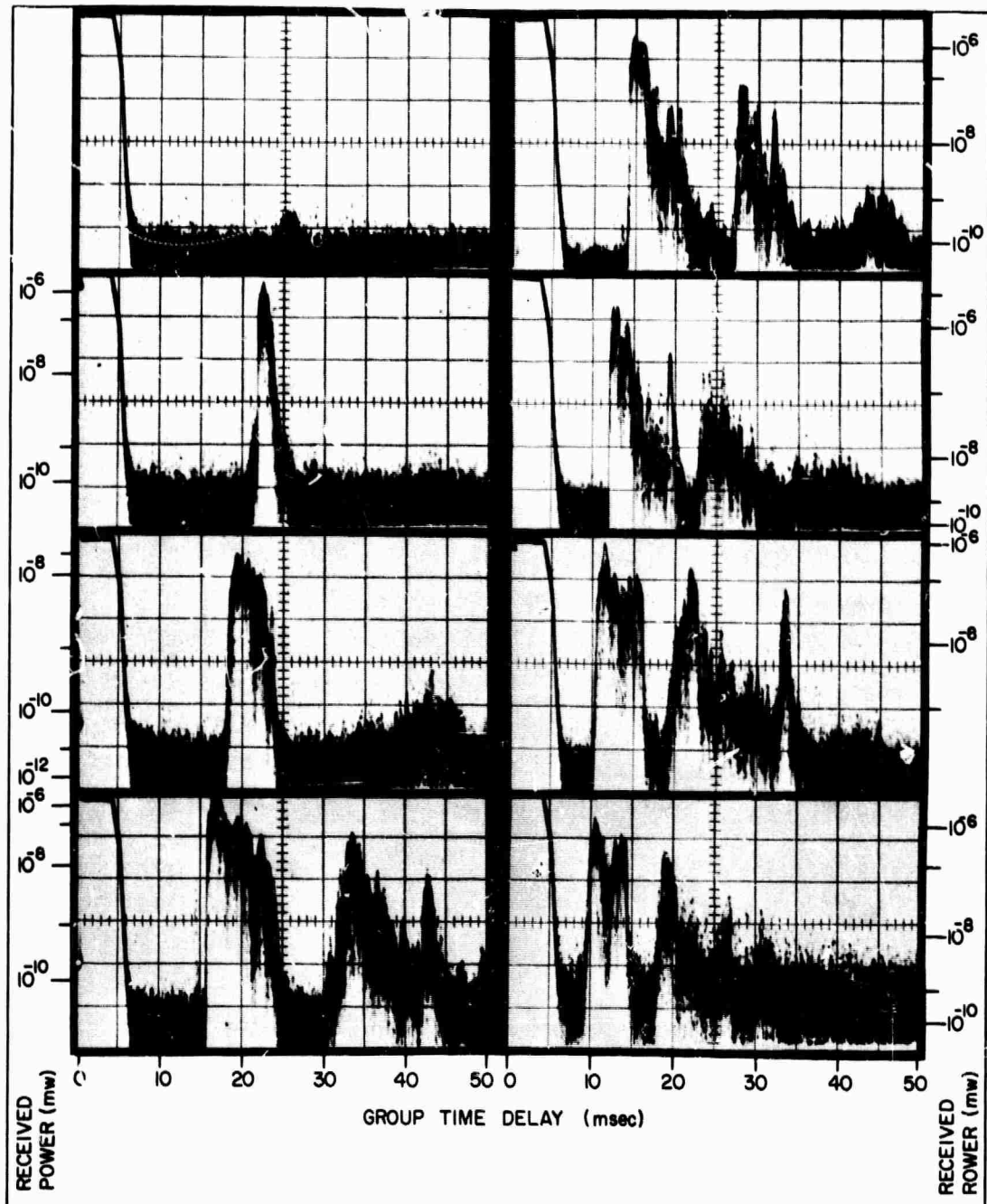

A RECORDS, 9 MAR 1965, 302° BEARING

FREQ.  
TIME  
XMTD. POWER

FREQ.  
TIME  
XMTD. POWER

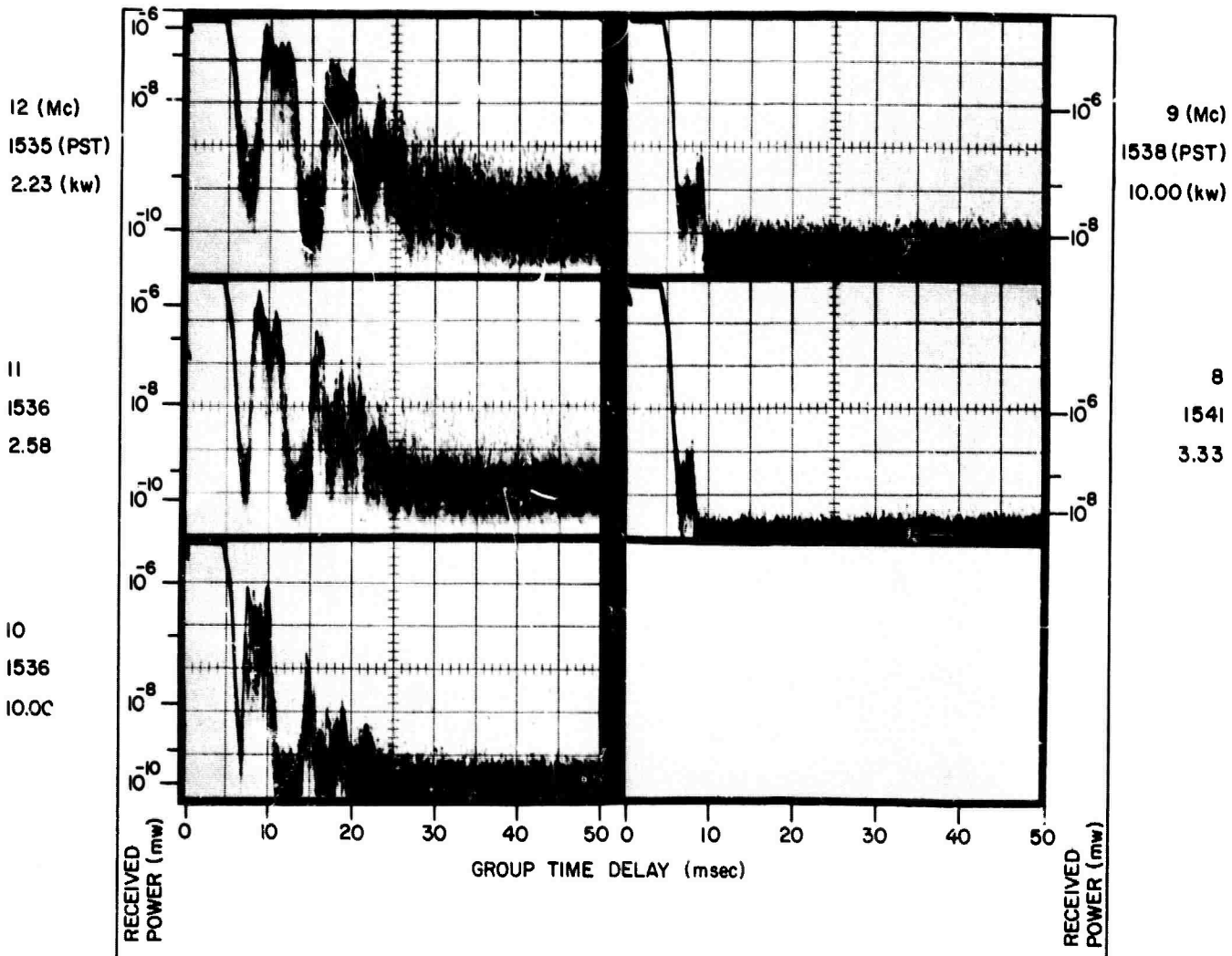

A RECORDS, 9 MAR 1965, 302° BEARING

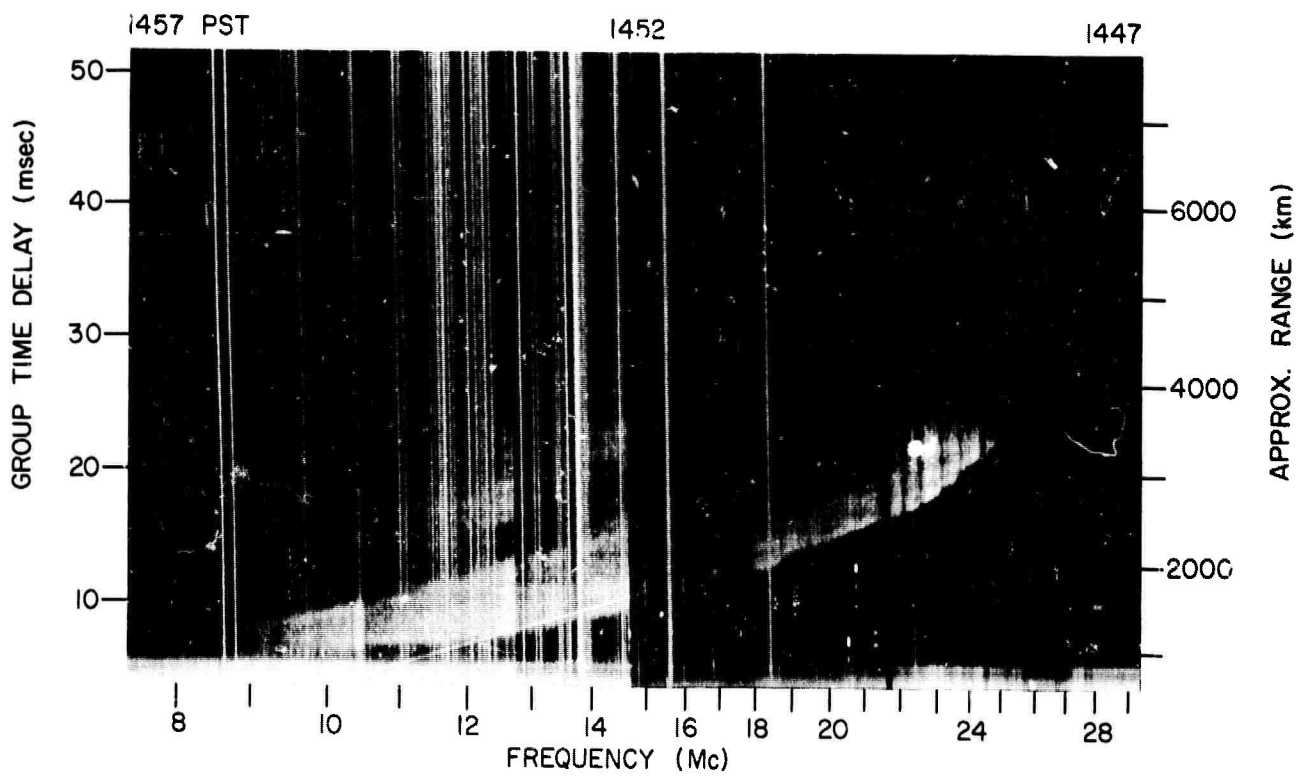
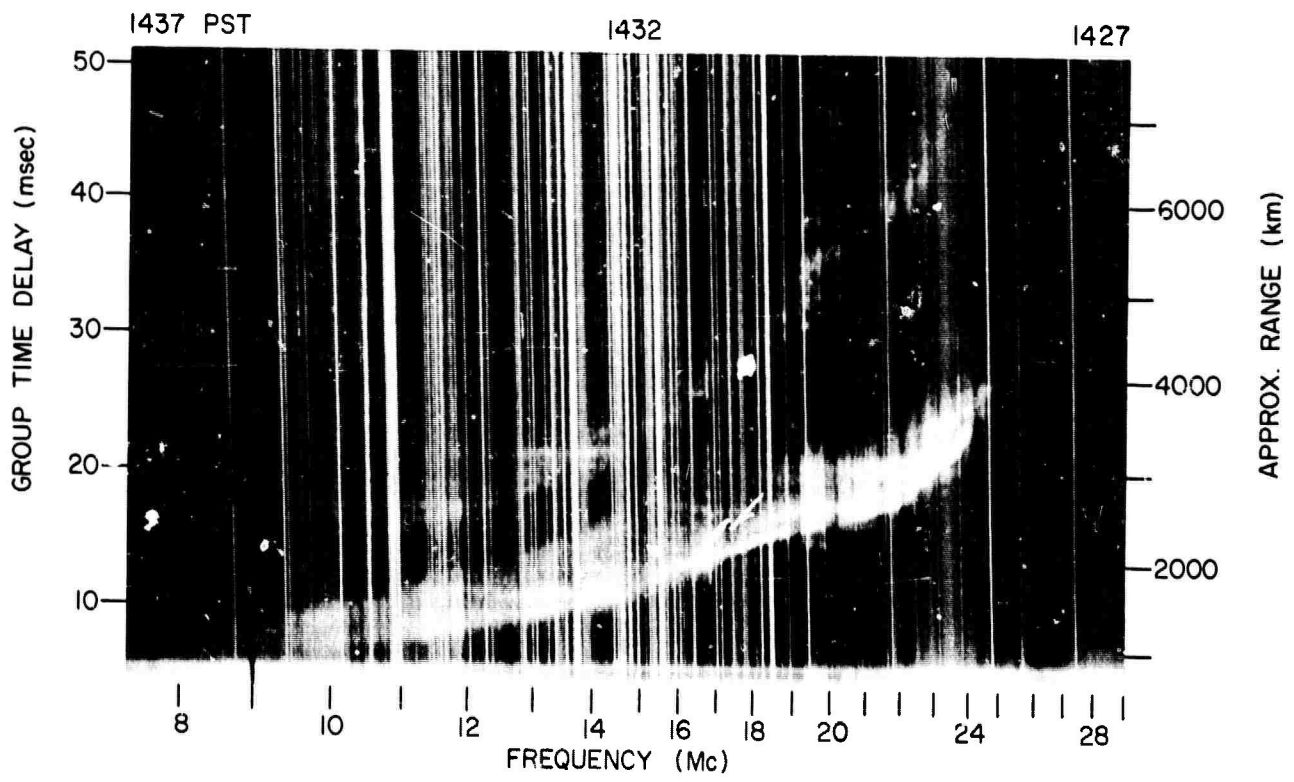
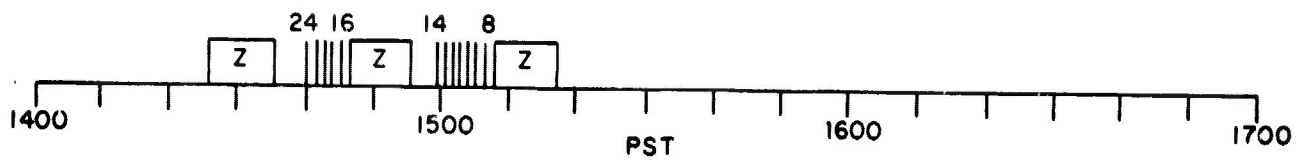

Z RECORDS, 10 MAR 1965, 302° BEARING



FREQ.  
TIME  
XMTD. POWER

FREQ.  
TIME  
XMTD. POWER

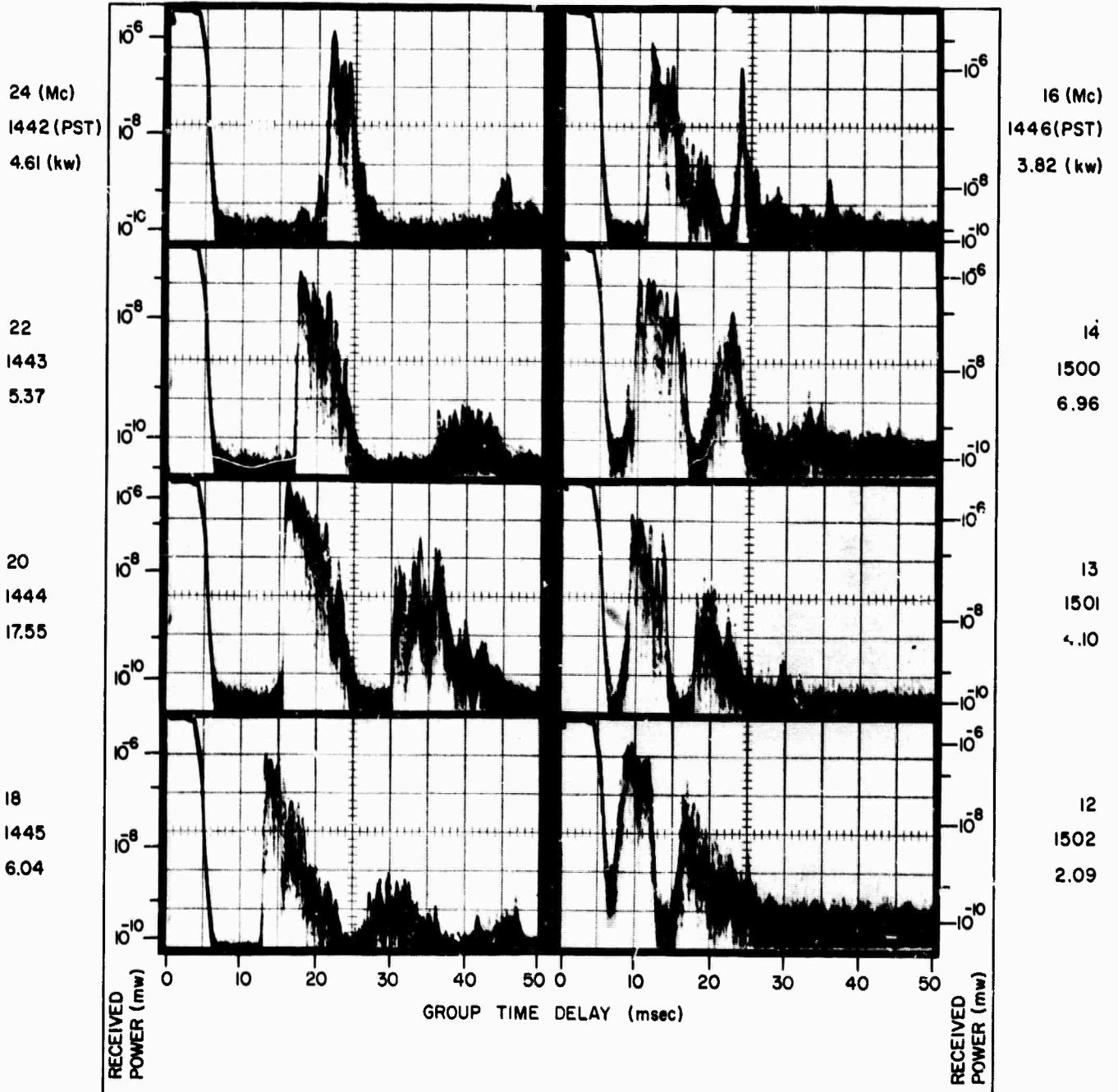

A RECORDS, 10 MAR 1965, 302° BEARING

FREQ.  
TIME  
XMTD. POWER

FREQ.  
TIME  
XMTD. POWER

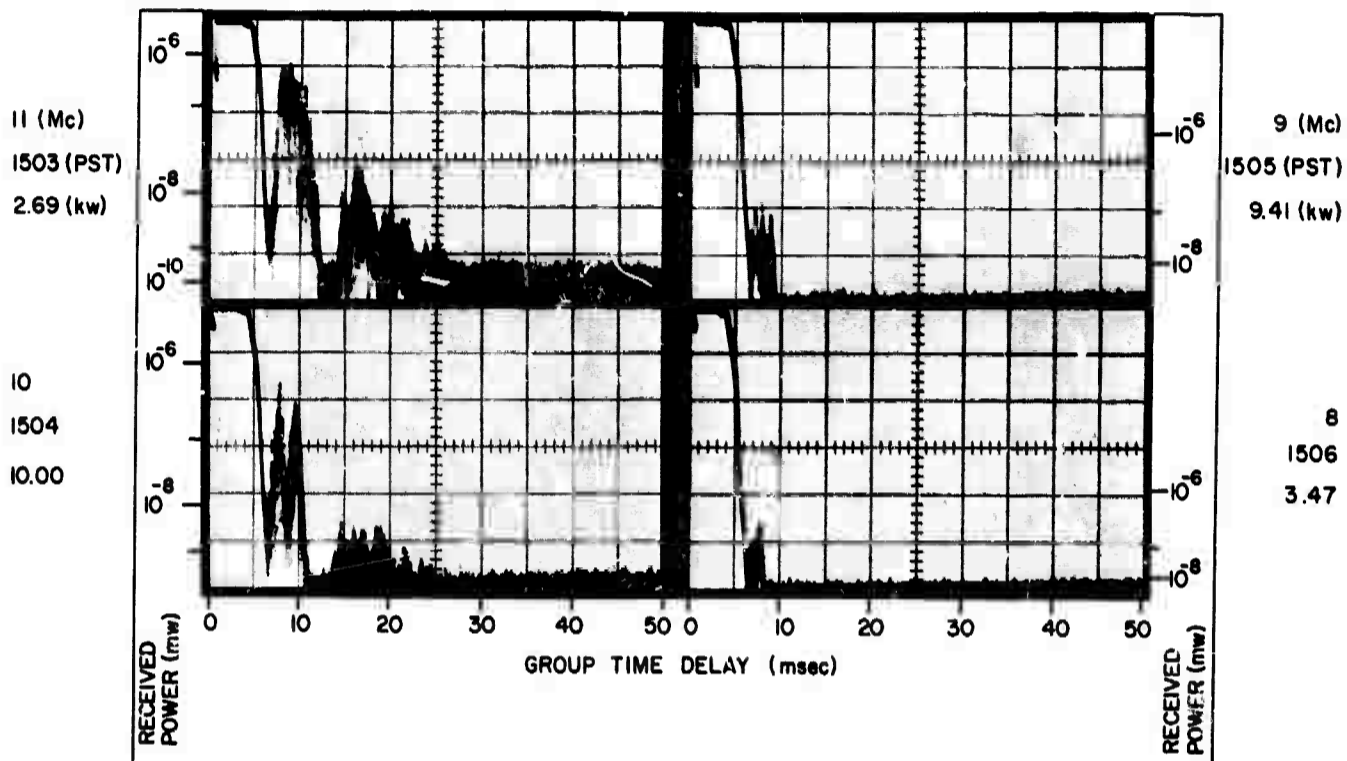

A RECORDS, 10 MAR 1965, 302° BEARING

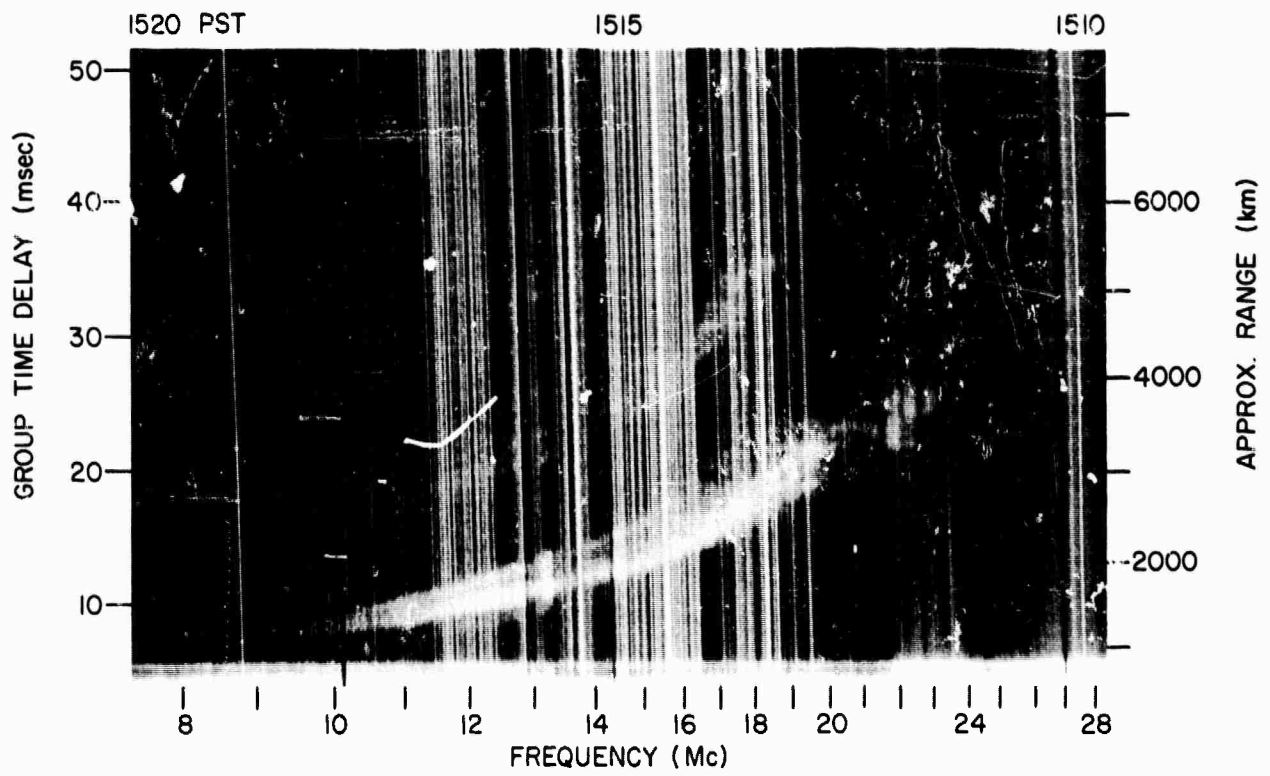
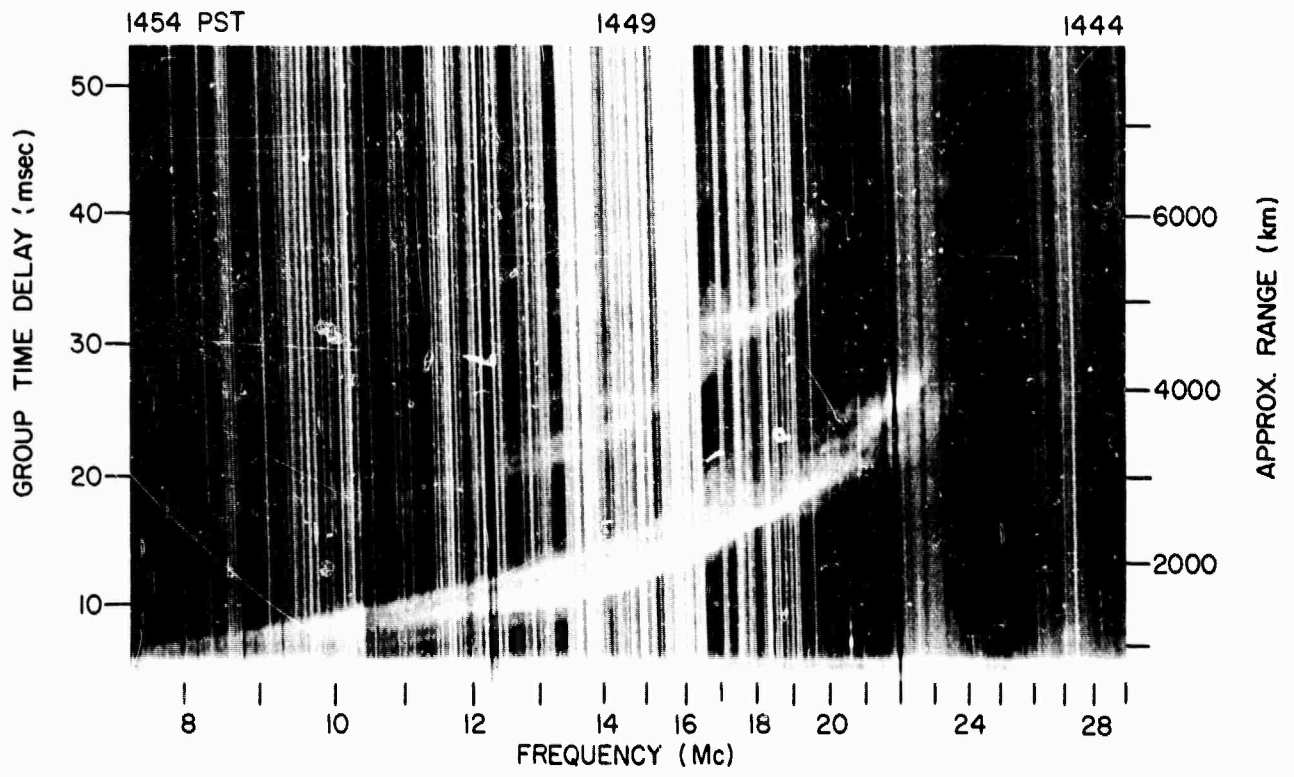
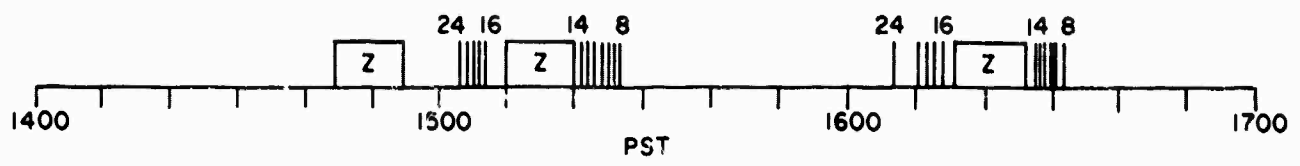

Z RECORDS, 11 MAR 1965, 302° BEARING

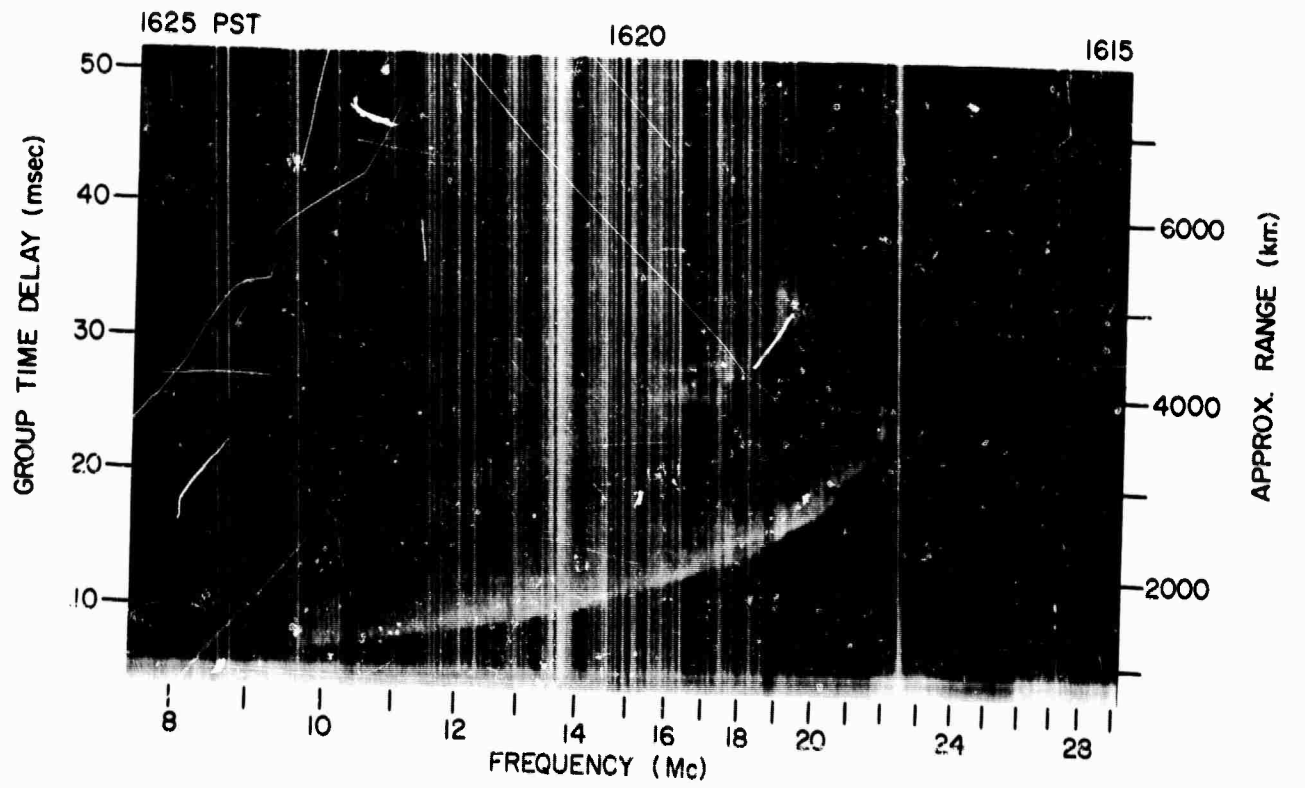

Z RECORD, 11 MAR 1965, 302° BEARING

FREQ.  
TIME  
XMTD. POWER

FREQ.  
TIME  
XMTD. POWER

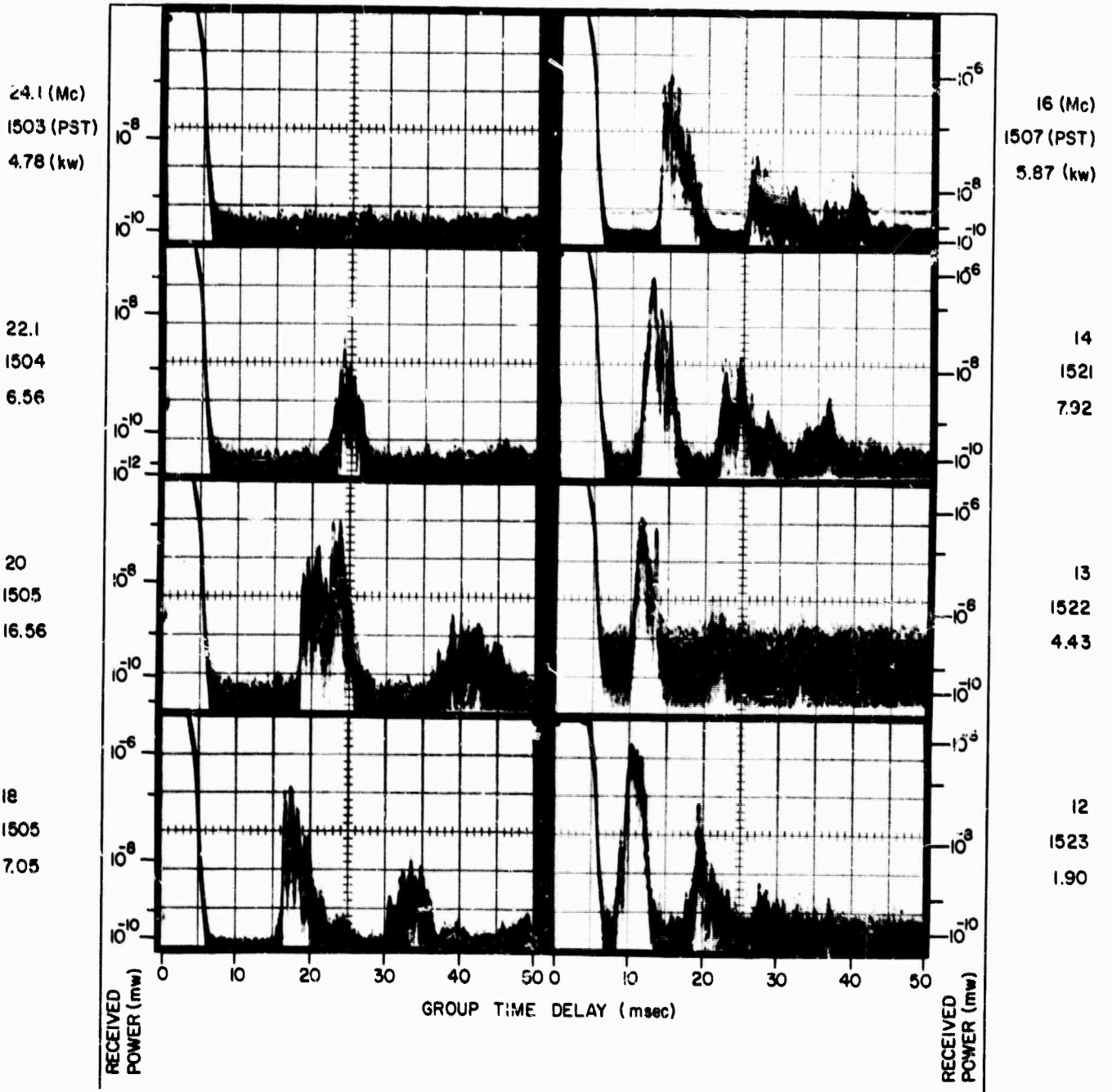

A RECORDS, 11 MAR 1965, 302° BEARING

FREQ.  
TIME  
XMTD. POWER

FREQ.  
TIME  
XMTD. POWER

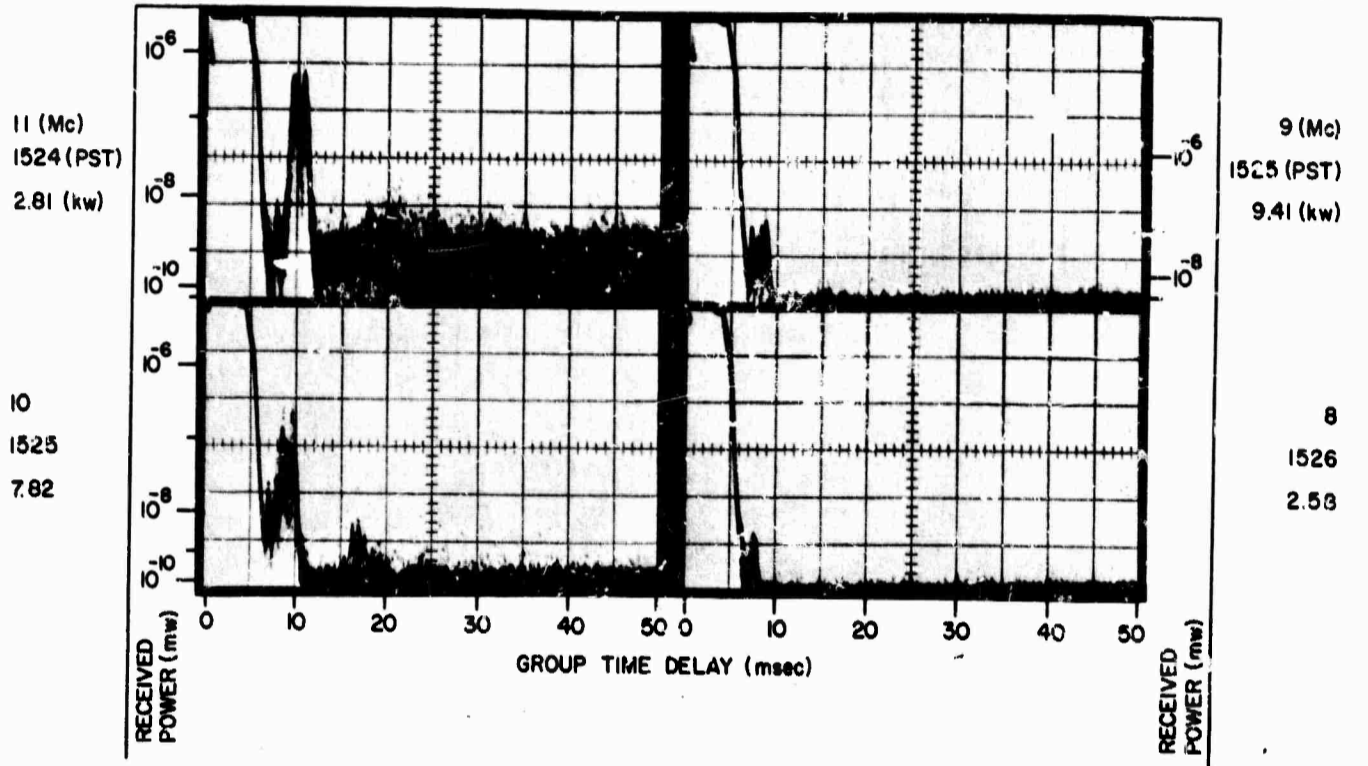

A RECORDS, 11 MAR 1965, 302° BEARING

FREQ.  
TIME  
XMTD. POWER

FREQ.  
TIME  
XMTD. POWER

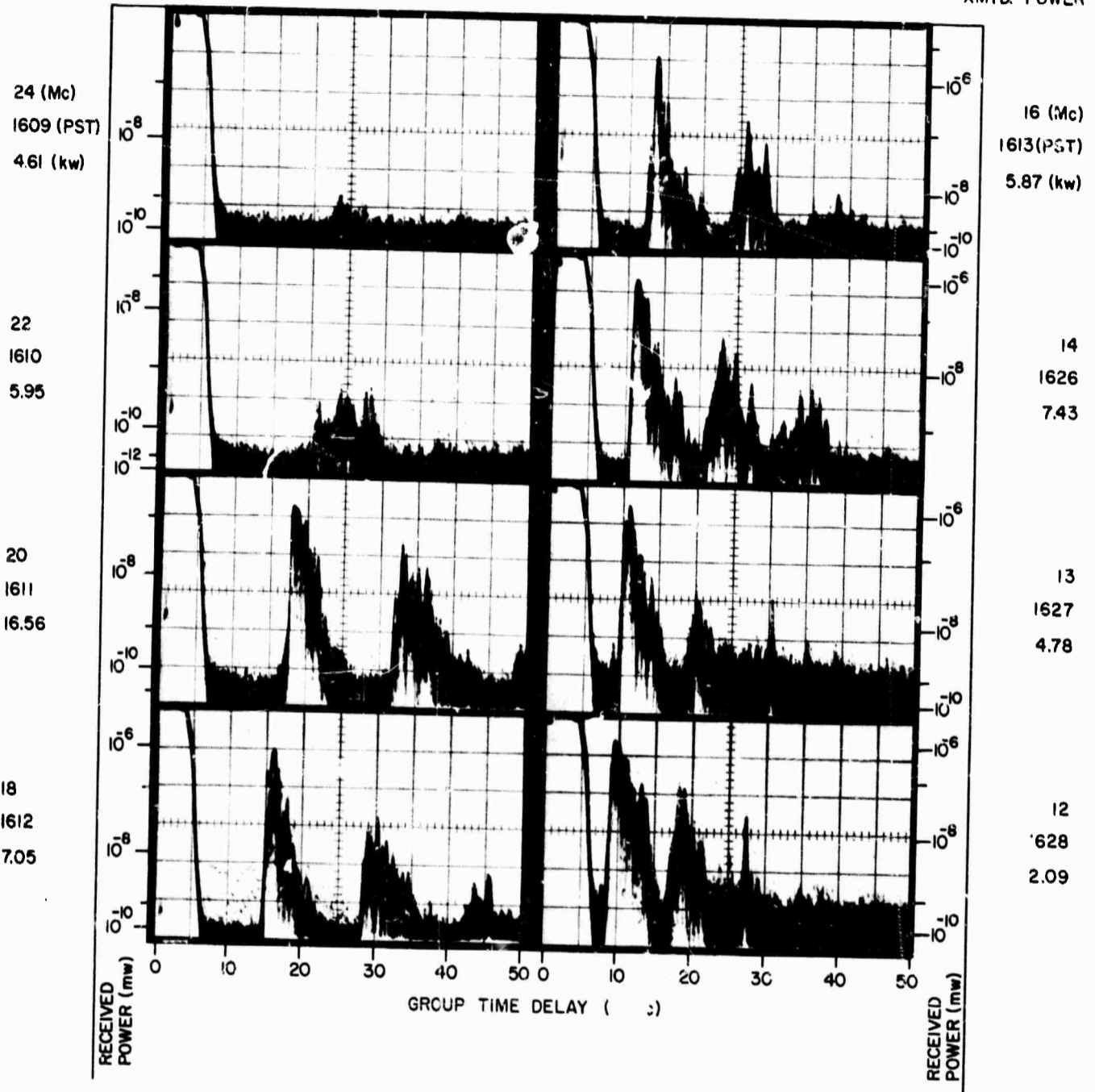

A RECORDS, 11 MAR 1965, 302° BEARING

FREQ.  
TIME  
XMTD. POWER

FREQ.  
TIME  
XMTD. POWER

11 (Mc)  
1628 (PST)  
2.69 (kw)

9 (Mc)  
1630 (PST)  
12.58 (kw)

10  
1629  
9.71

8  
1631  
2.95

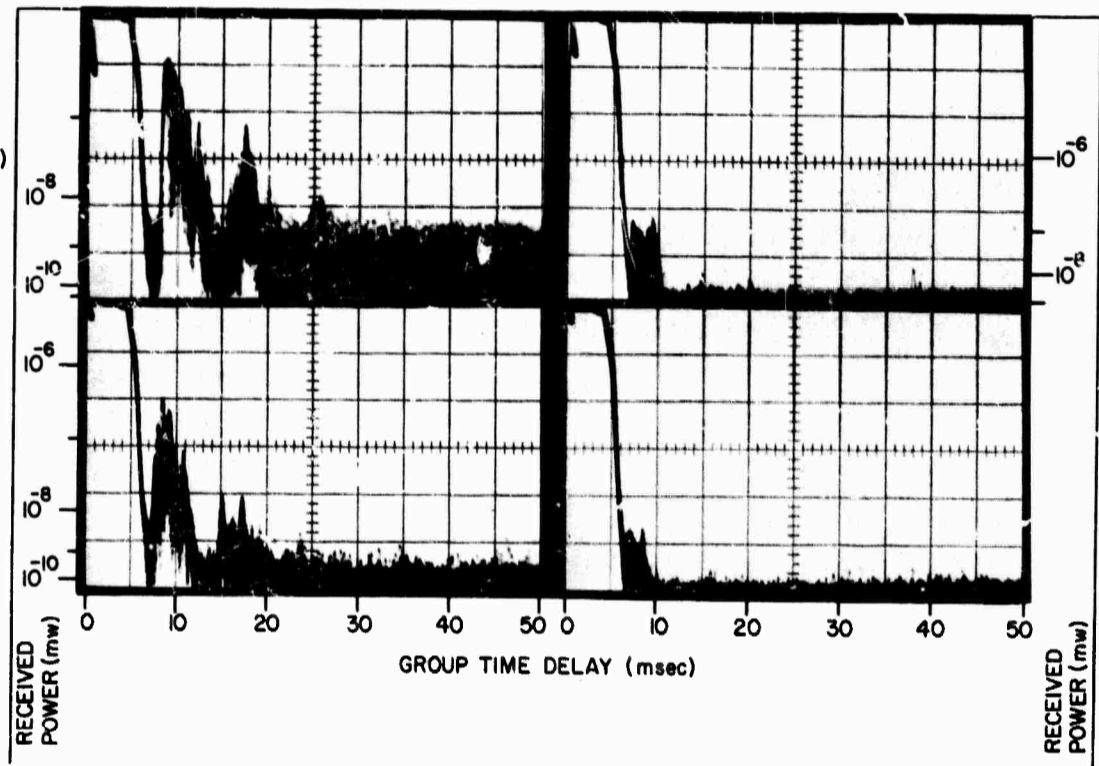

A RECORDS, 11 MAR 1965, 302° BEARING

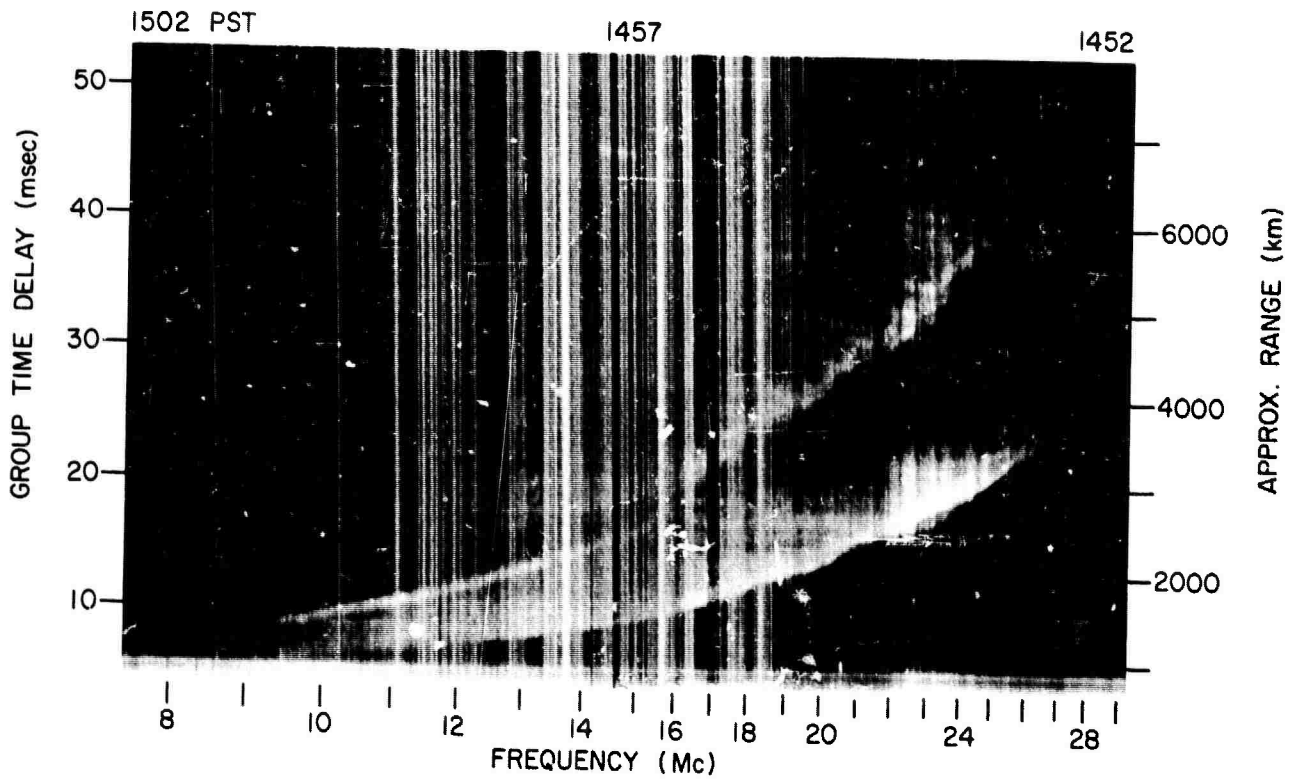

Z RECORD, 12 MAR 1965, 302° BEARING

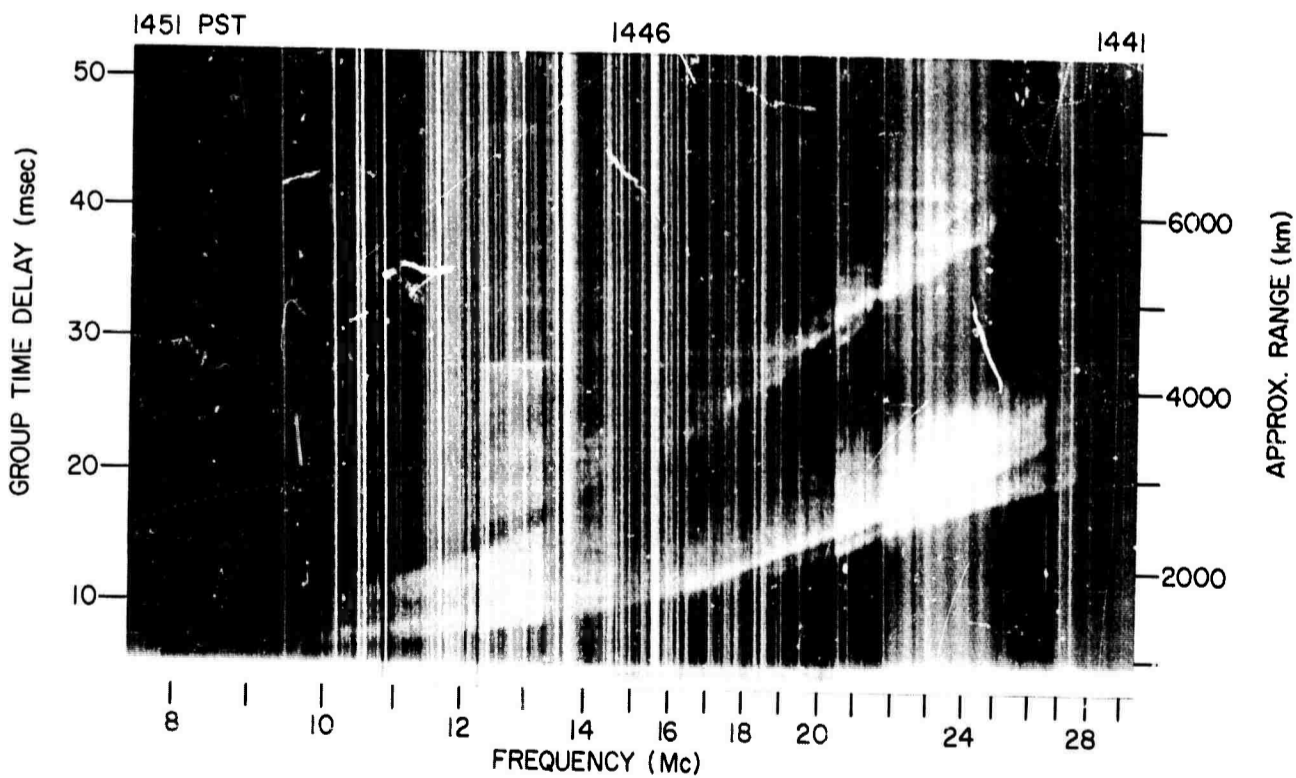
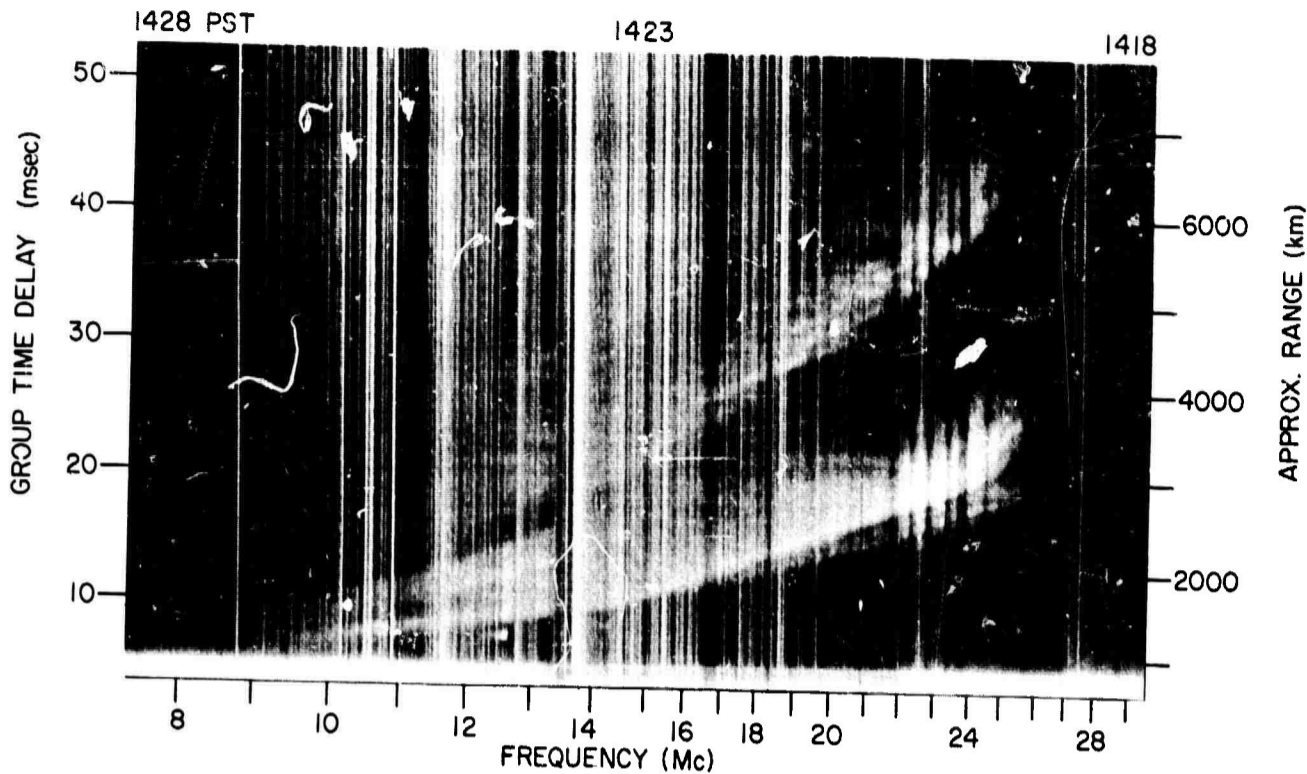
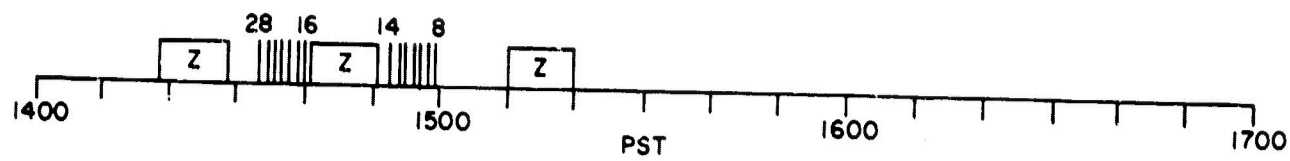

Z RECORDS, 16 MAR 1965, 302° BEARING

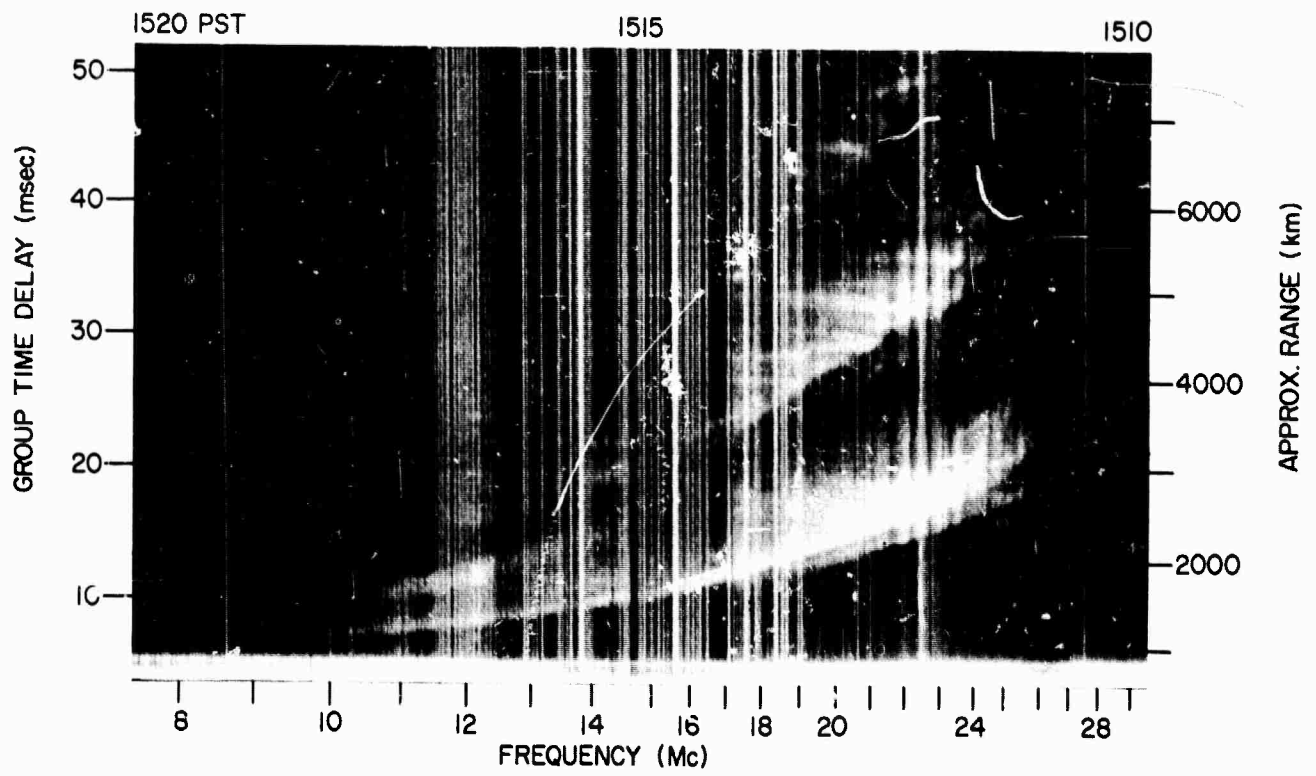

Z RECORD, 16 MAR 1965, 302° BEARING

FREQ.  
TIME  
XMTD. POWER

FREQ.  
TIME  
XMTD. POWER

28 (Mc)  
1433 (PST)  
0.61 (kw)

20 (Mc)  
1437 (PST)  
19.61 (kw)

26  
1434  
7.53

18  
1439  
5.12

24  
1435  
4.60

16  
1440  
5.87

22  
1436  
4.82

14  
1453  
6.50

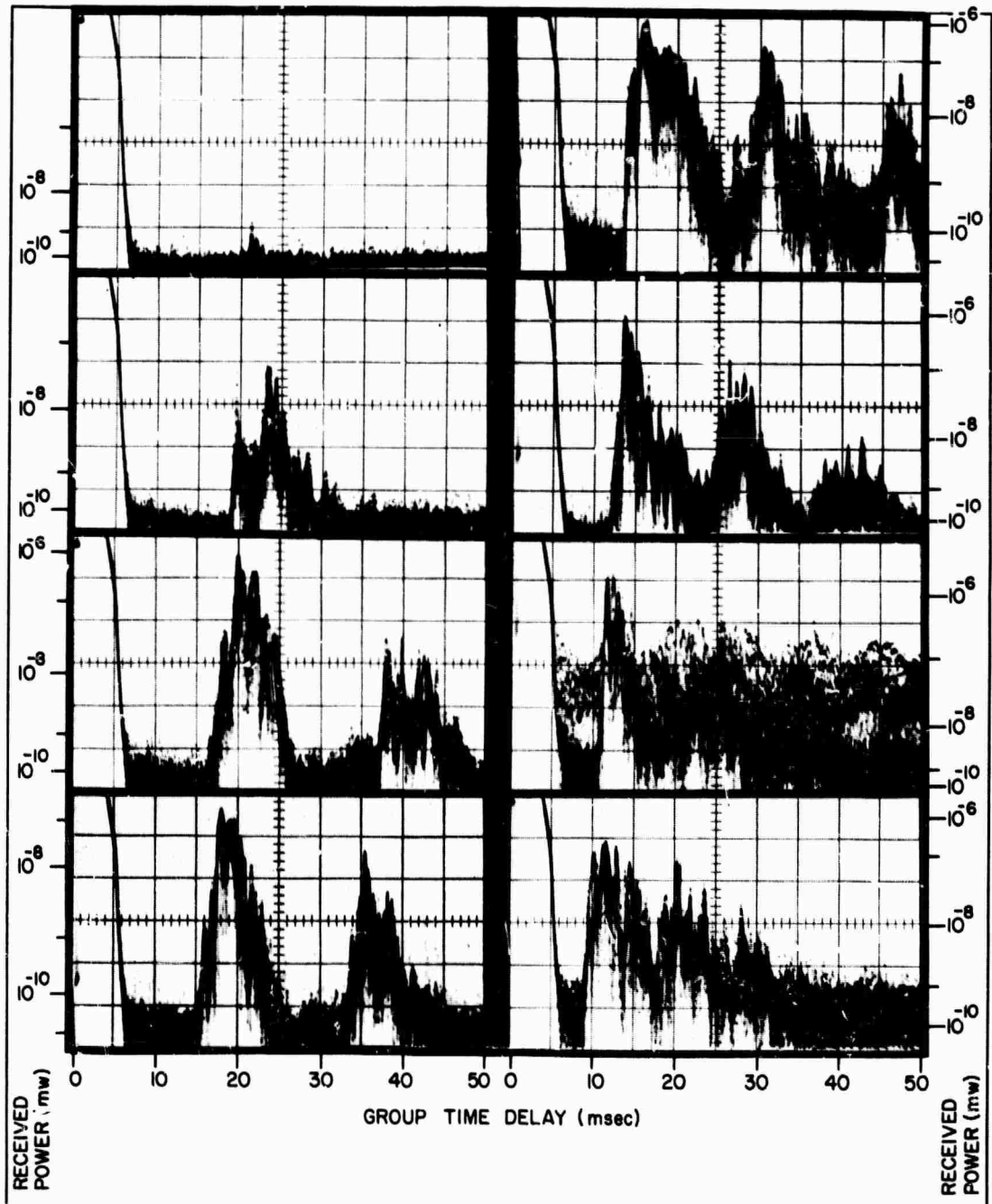

A RECORDS, 16 MAR 1965, 302° BEARING

FREQ.  
TIME  
XMTD. POWER

FREQ.  
TIME  
XMTD. POWER

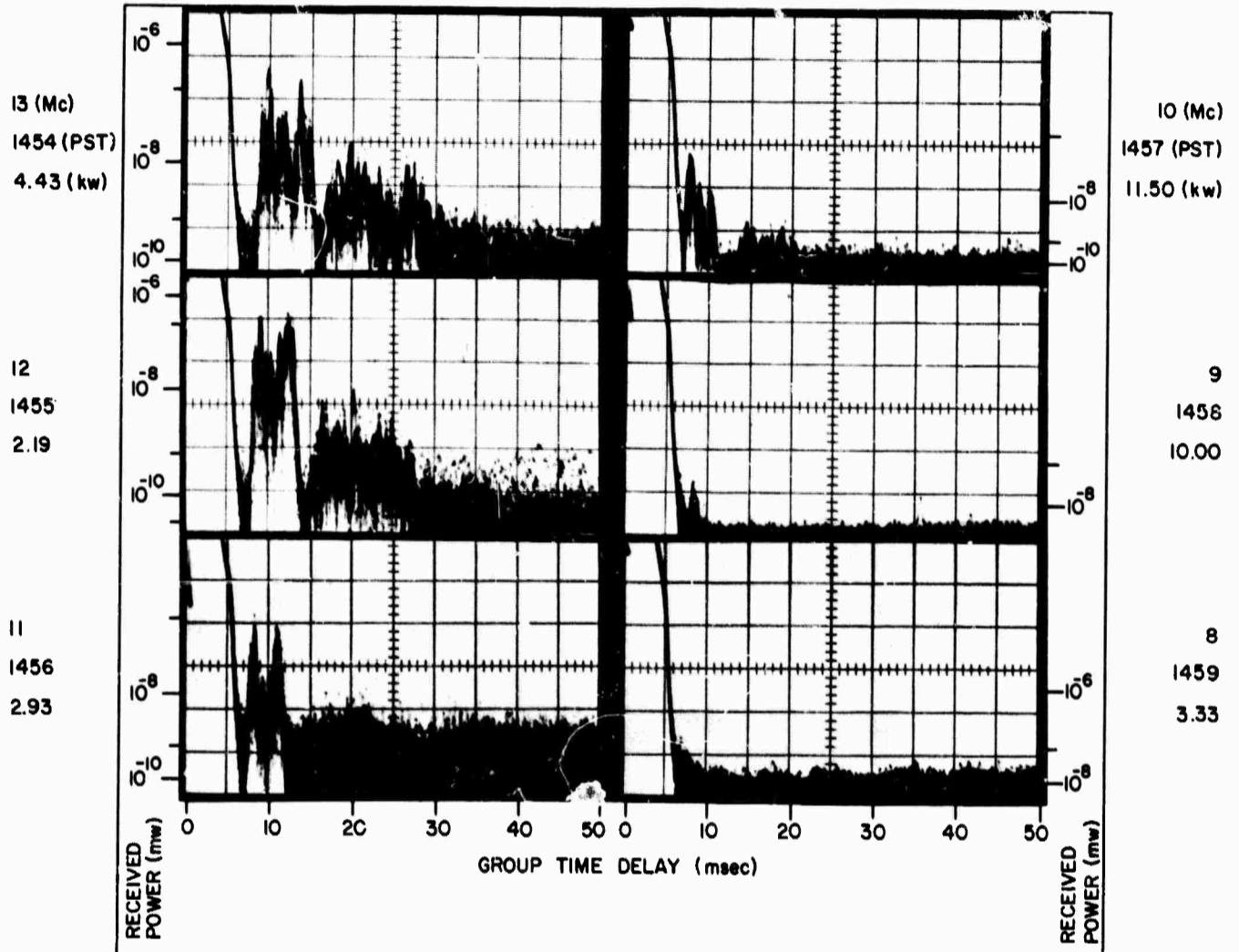

A RECORDS, 16 MAR 1965, 302° BEARING

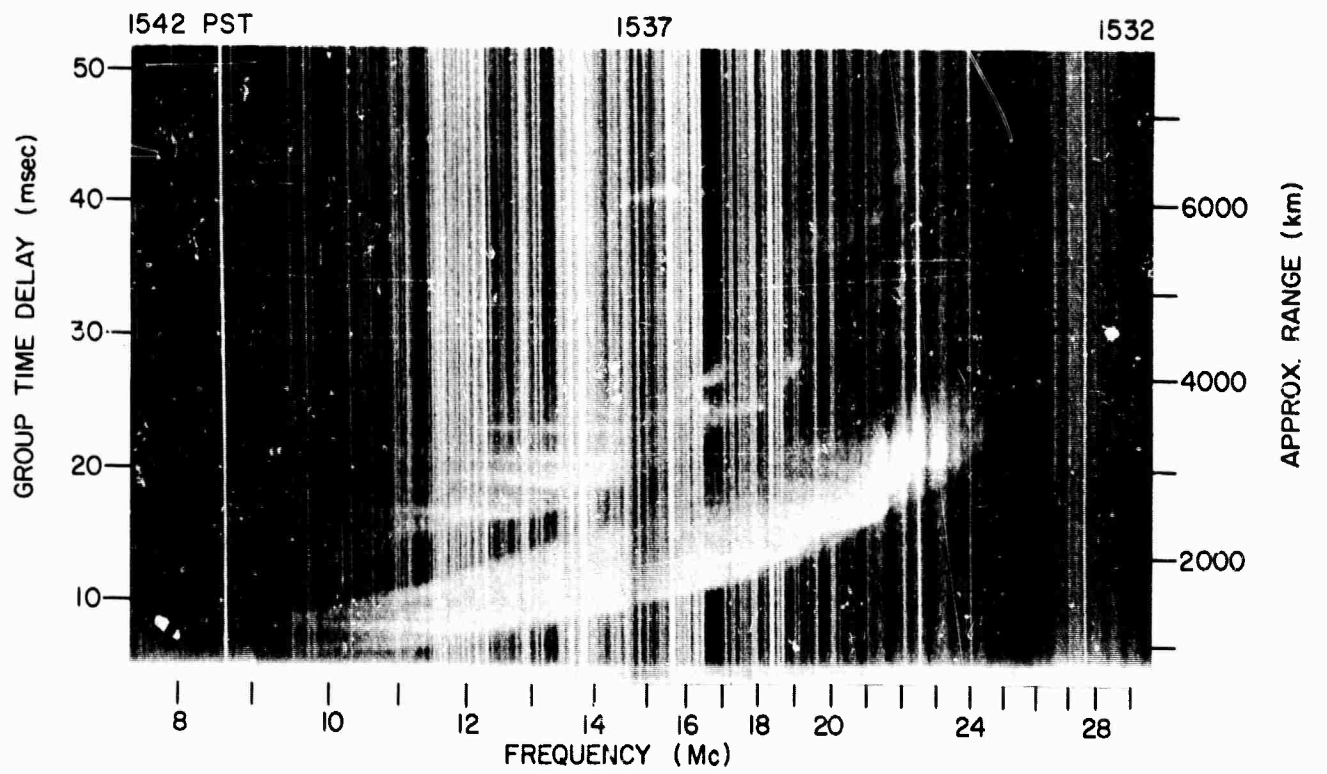
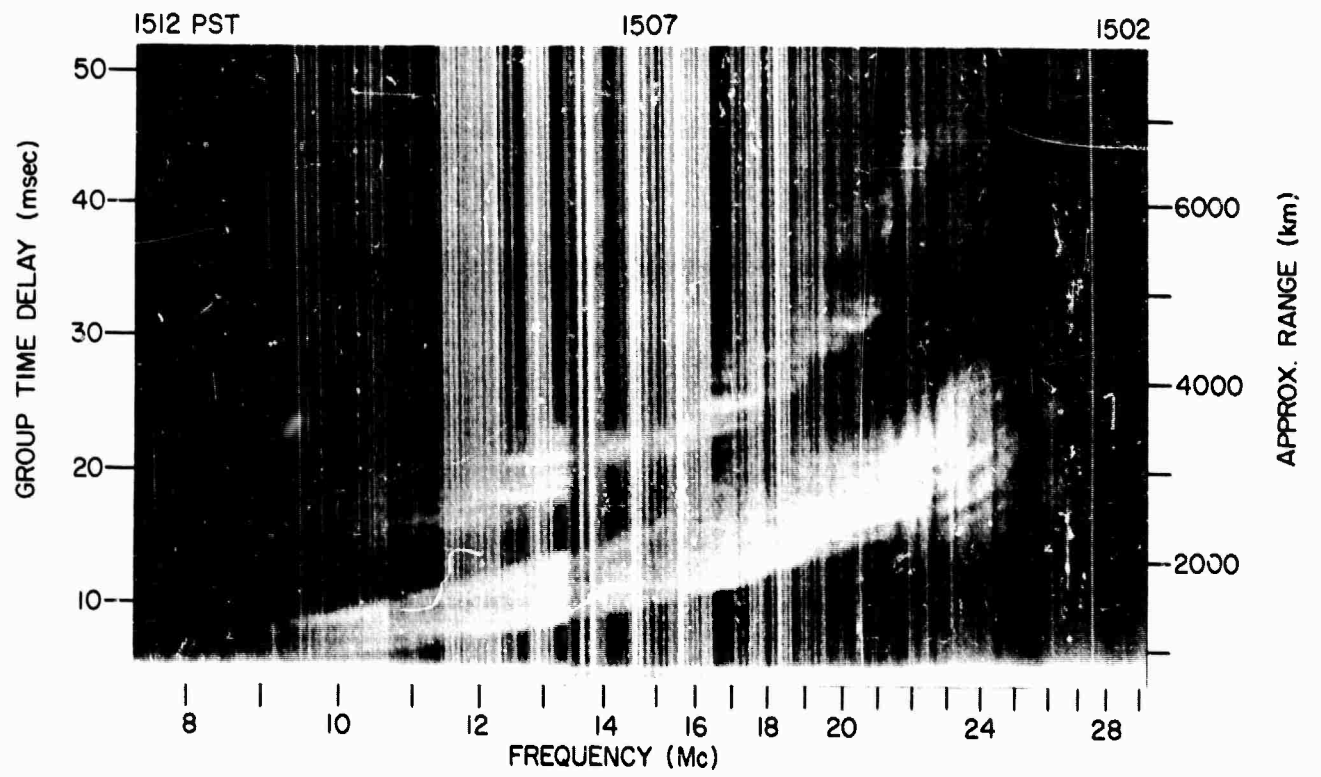

Z RECORDS, 18 MAR 1965, 302° BEARING

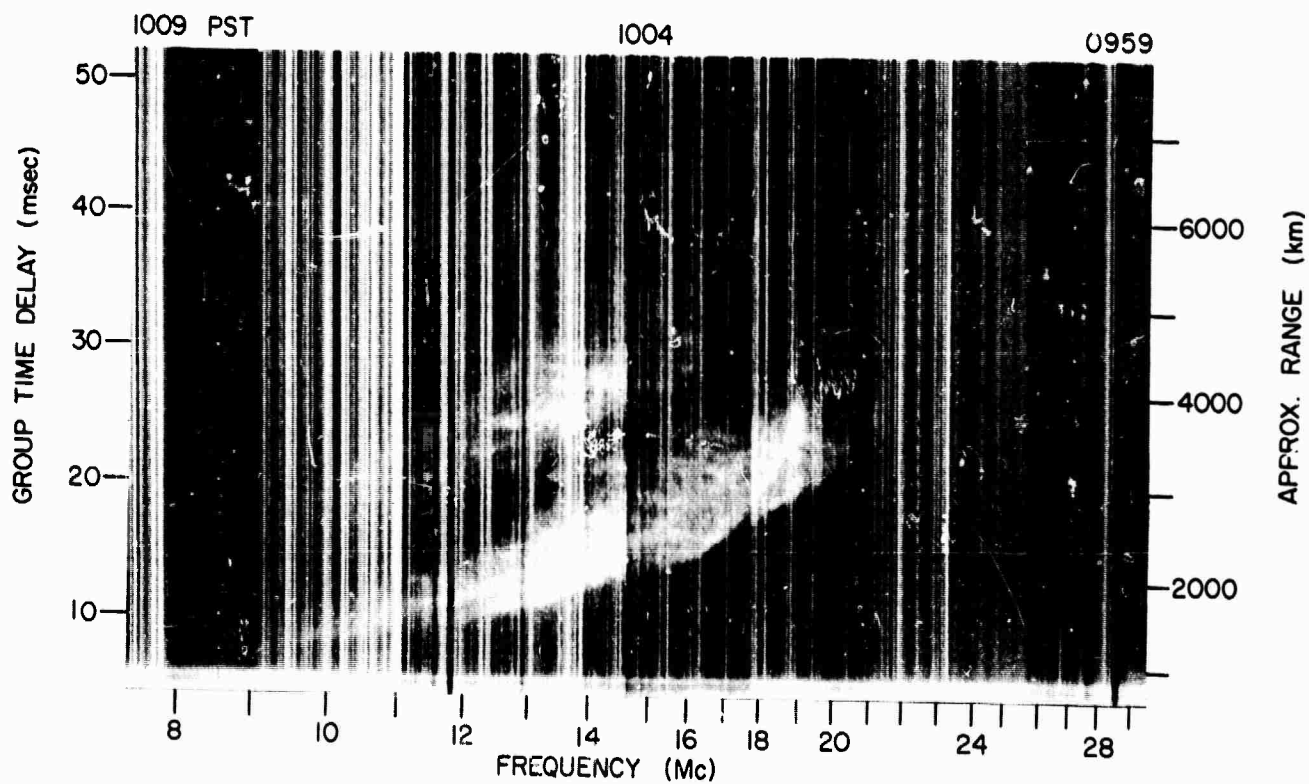
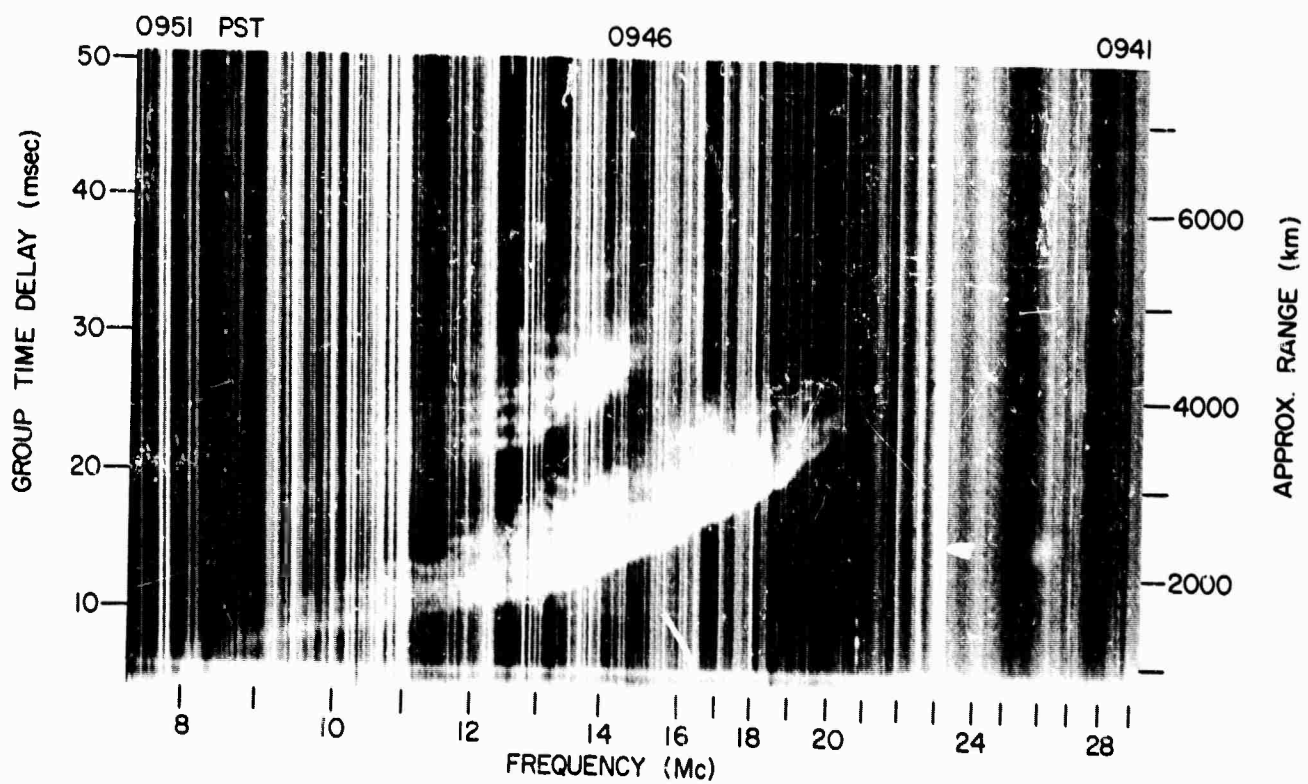
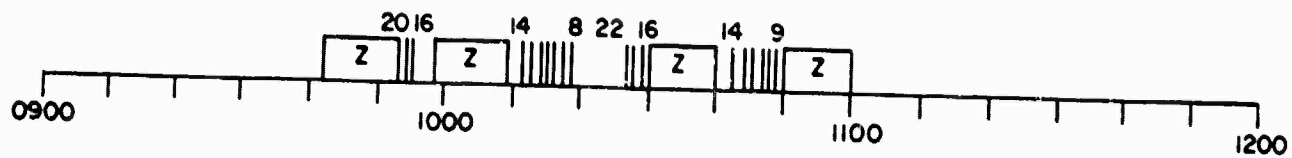

Z RECORDS, 22 MAR 1965, 302° BEARING

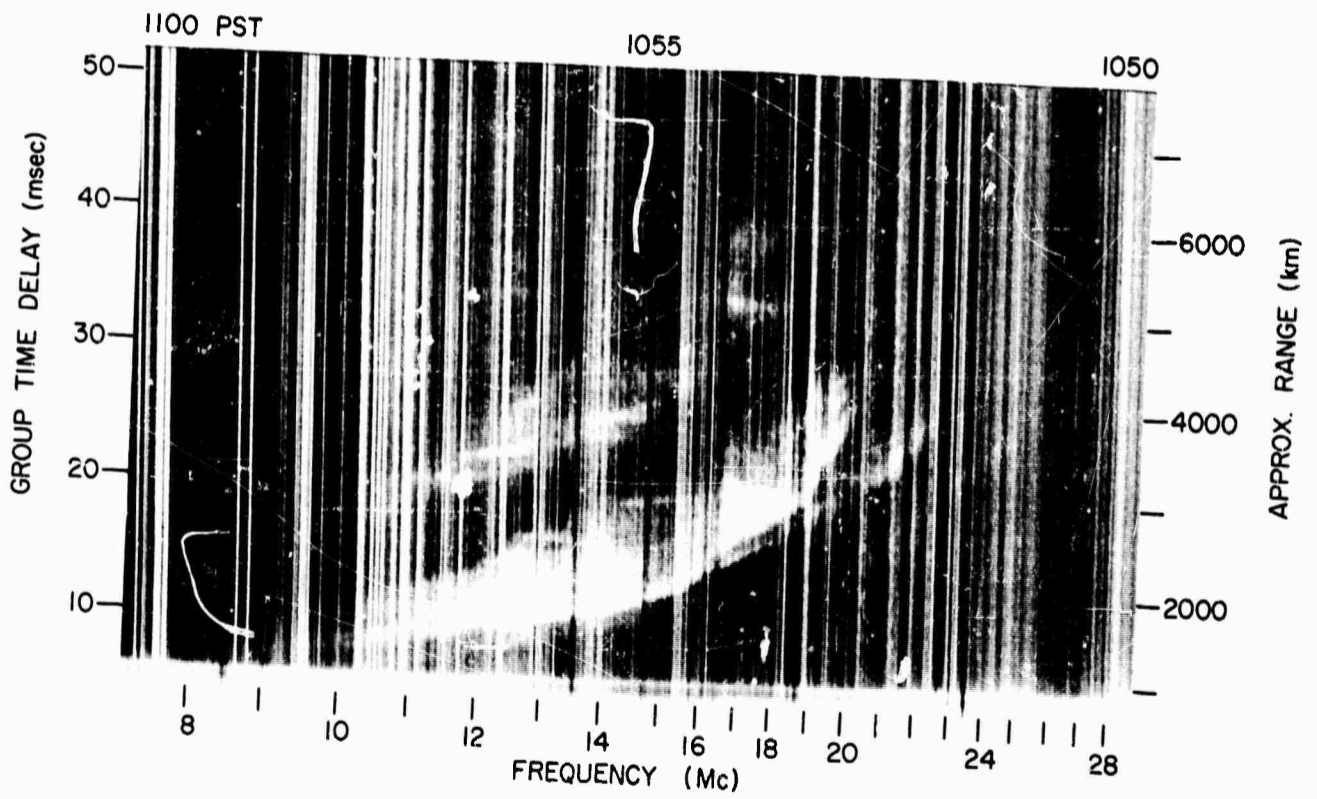
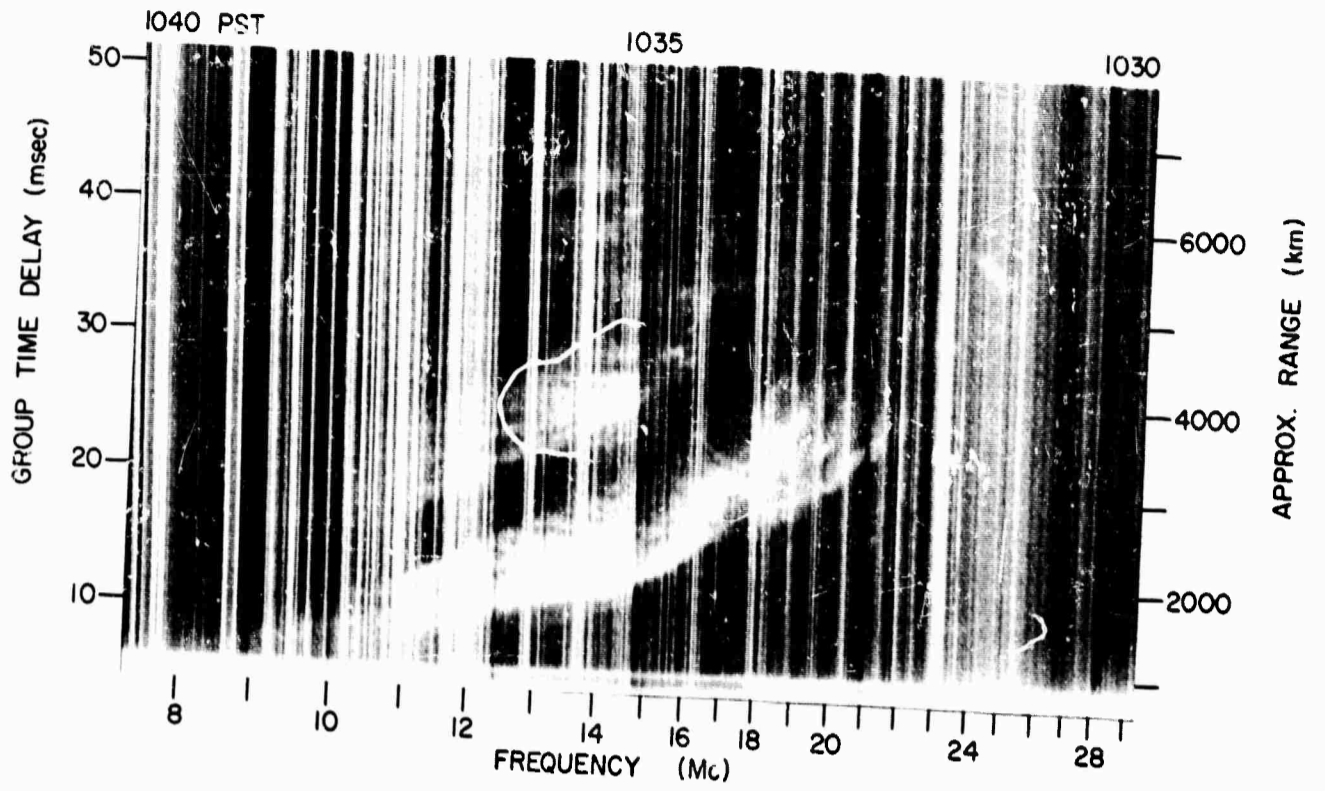

Z RECORDS, 22 MAR 1965, 302° BEARING

FREQ.  
TIME  
XMTD. POWER

FREQ.  
TIME  
XMTD. POWER

20 (Mc)  
0957 (PST)  
19.61 (kw)

14 (Mc)  
1011 (PST)  
7.43 (kw)

18  
0958  
6.54

13  
1012  
4.10

16  
0958  
5.87

12  
1013  
2.19

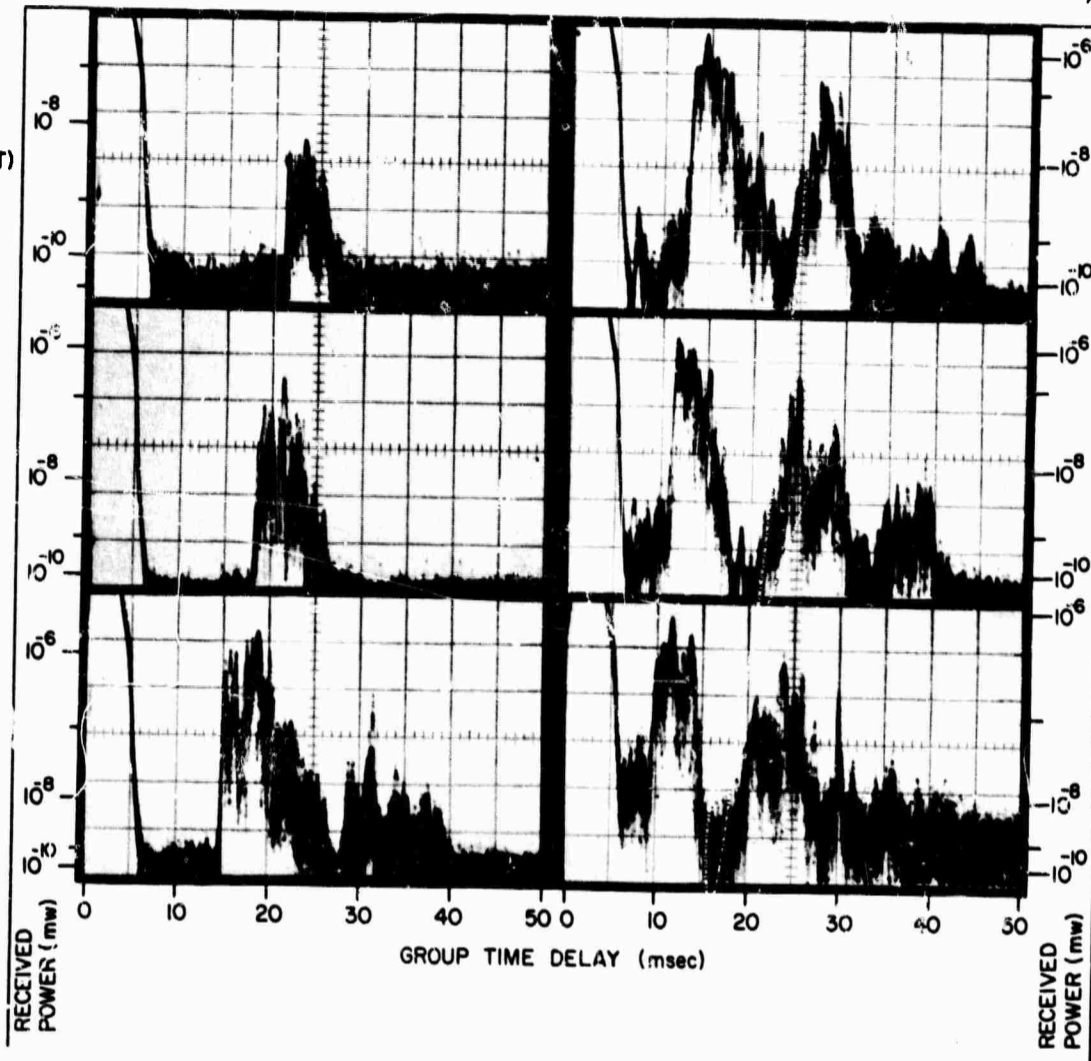

A RECORDS, 22 MAR 1965, 302° BEARING

FREQ.  
TIME  
XMTD. POWER

FREQ.  
TIME  
XMTD. POWER

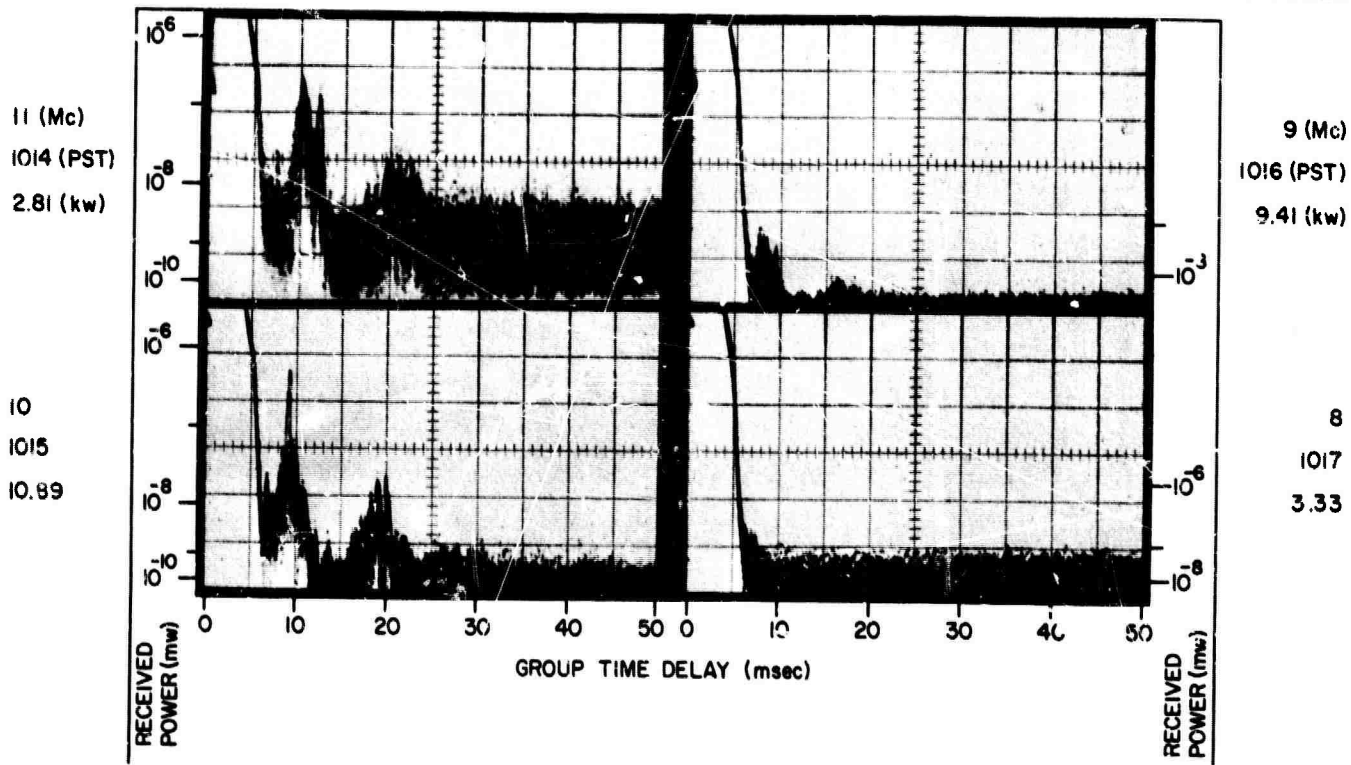

A RECORDS, 22 MAR 1965, 302° BEARING

FREQ.  
TIME  
XMTD. POWER

FREQ.  
TIME  
XMTD. POWER

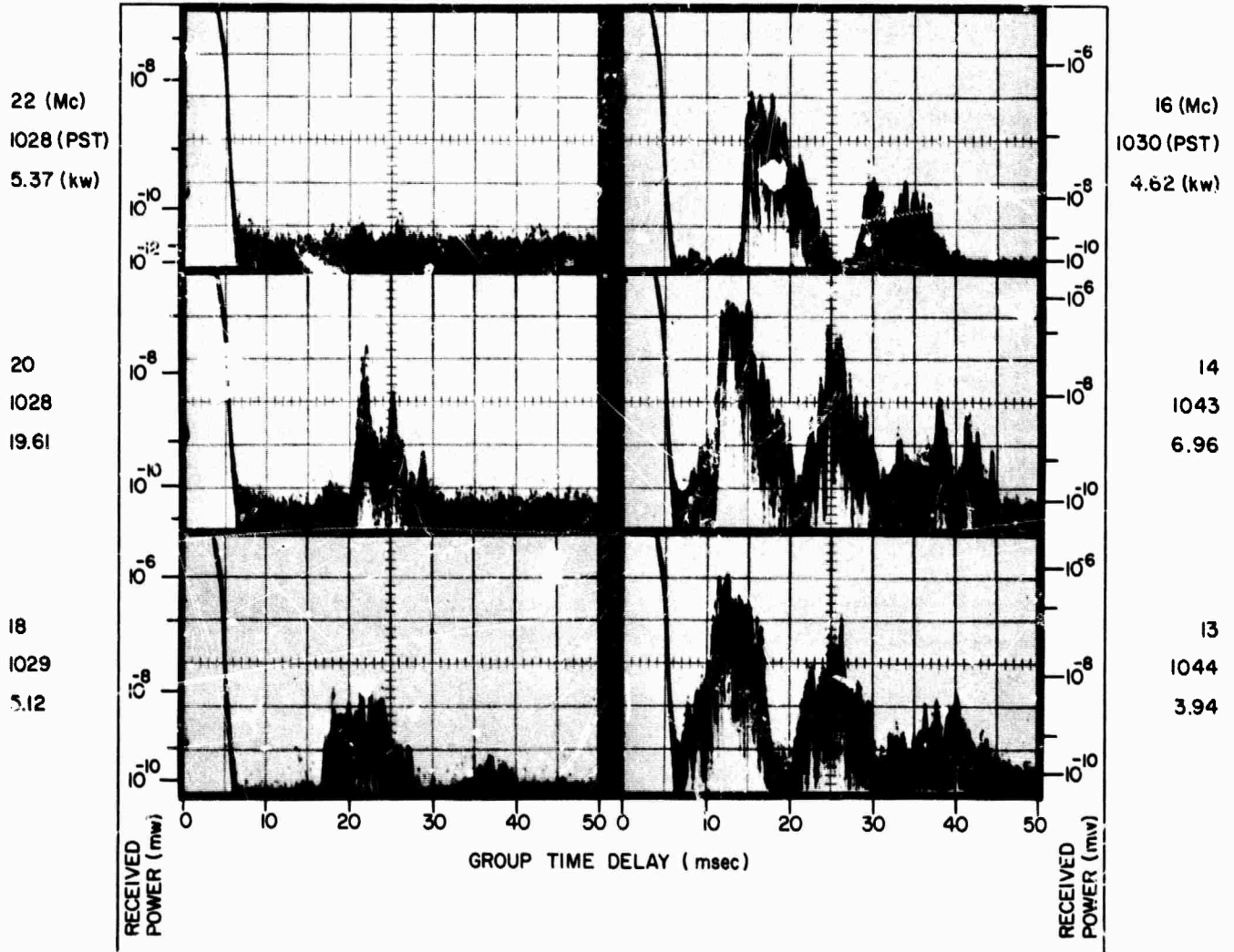

A RECORDS, 22 MAR 1965, 302° BEARING

FREQ.  
TIME  
XMTD. POWER

FREQ.  
TIME  
XMTD. POWER

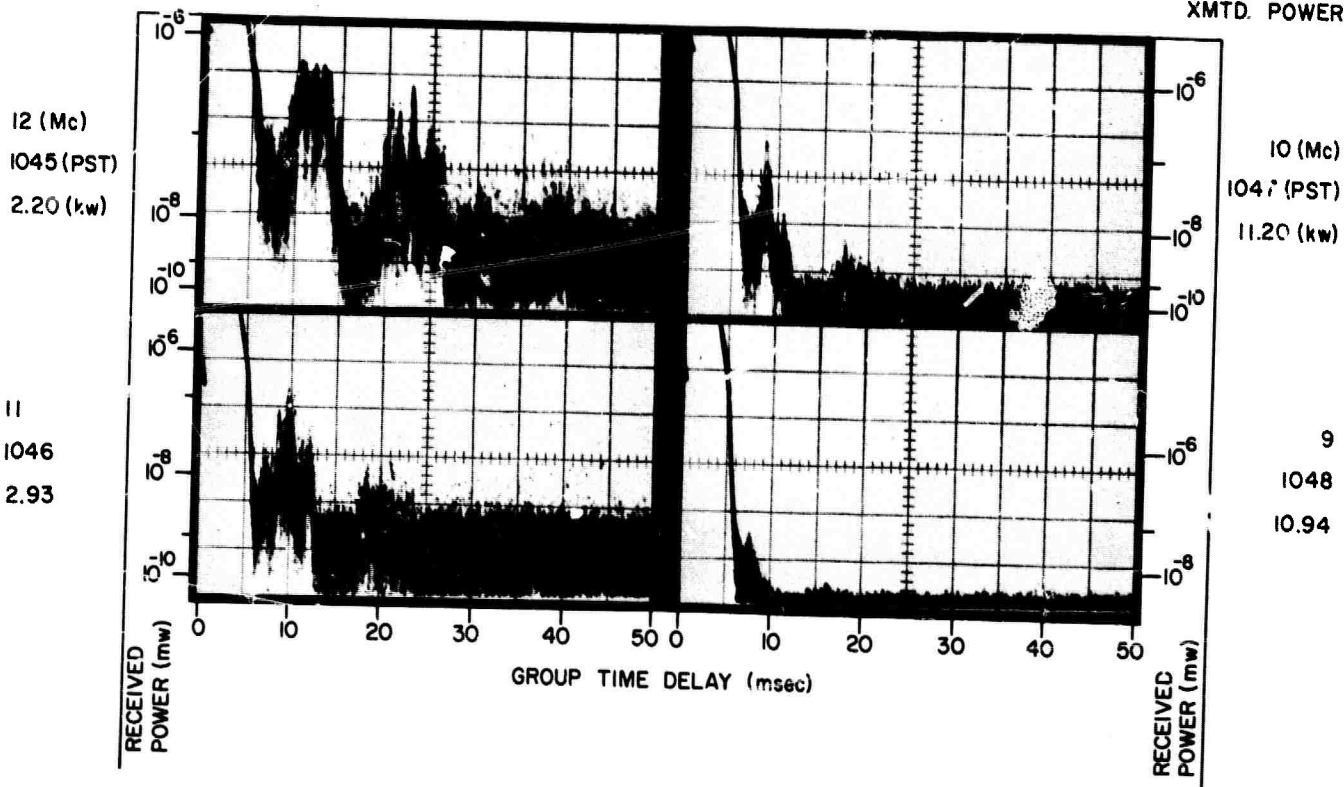

A RECORDS, 22 MAR 1965, 302° BEARING

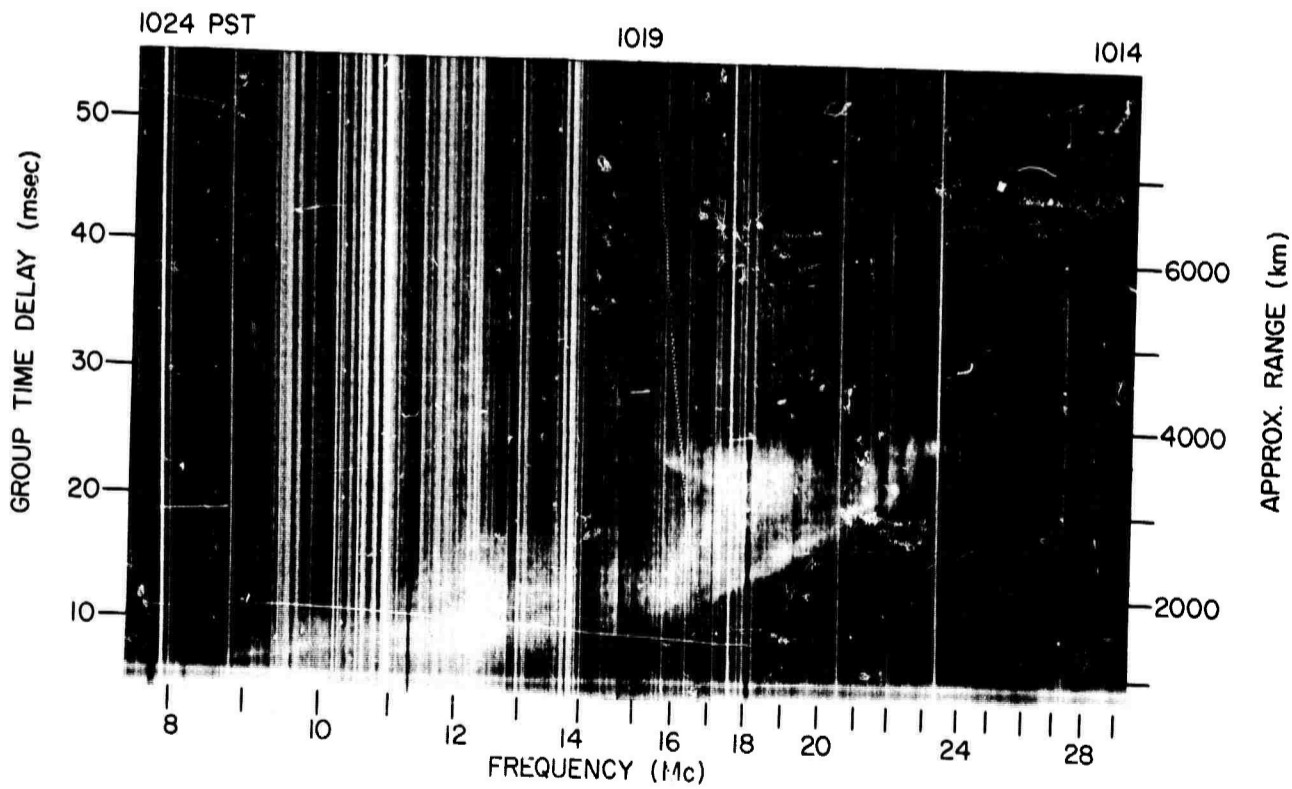
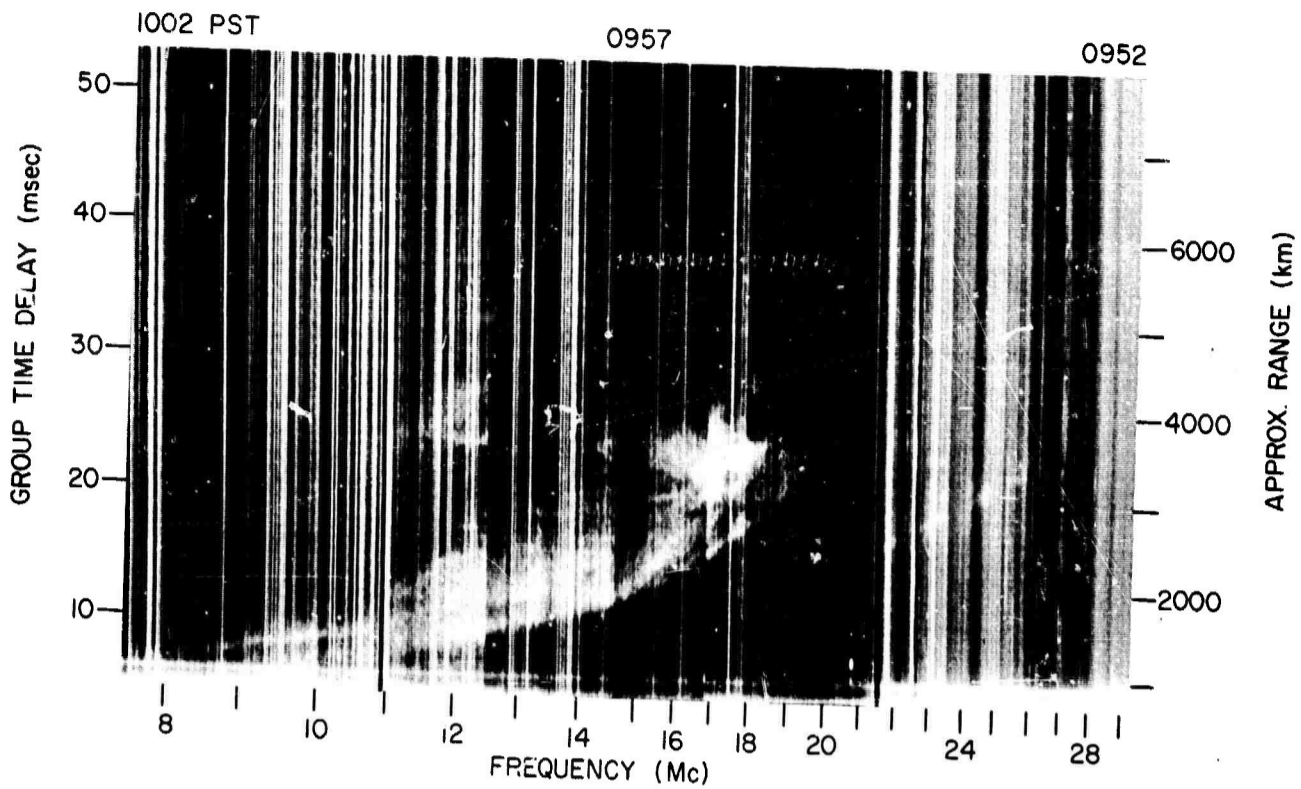
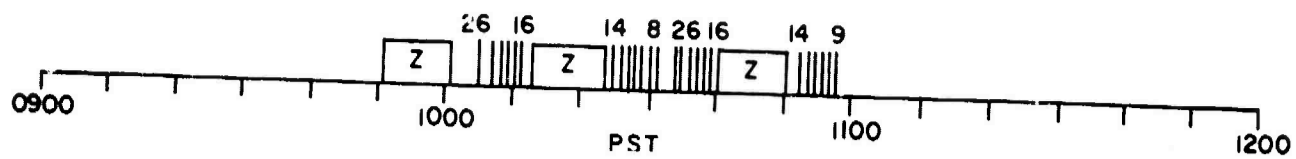

Z RECORDS, 23 MAR 1965, 302° BEARING



FREQ.  
TIME  
XMTD. POWER

FREQ.  
TIME  
XMTD. POWER

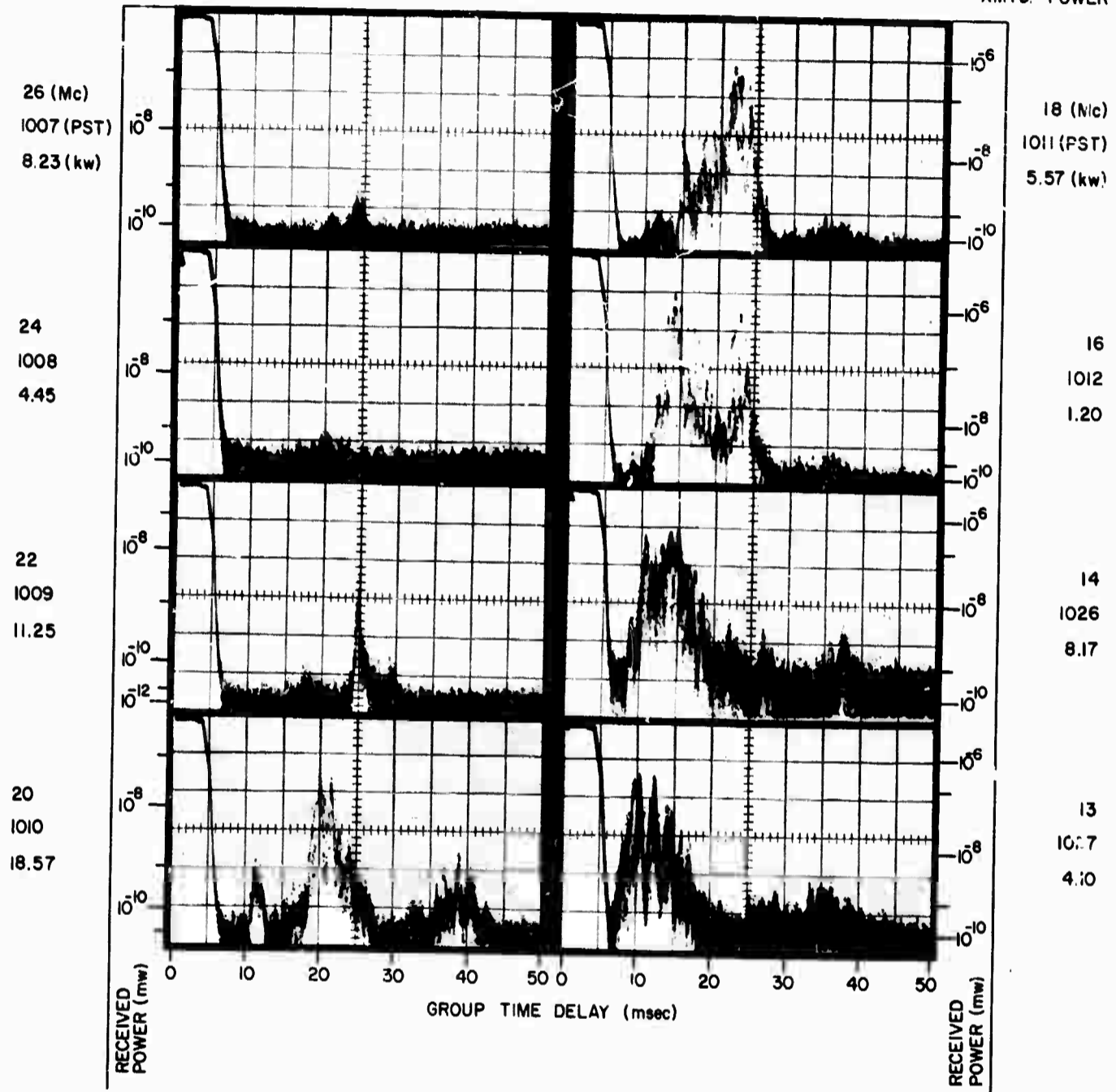

A RECORDS, 23 MAR 1965, 302° BEARING

FREQ.  
TIME  
XMTD. POWER

FREQ.  
TIME  
XMTD. POWER

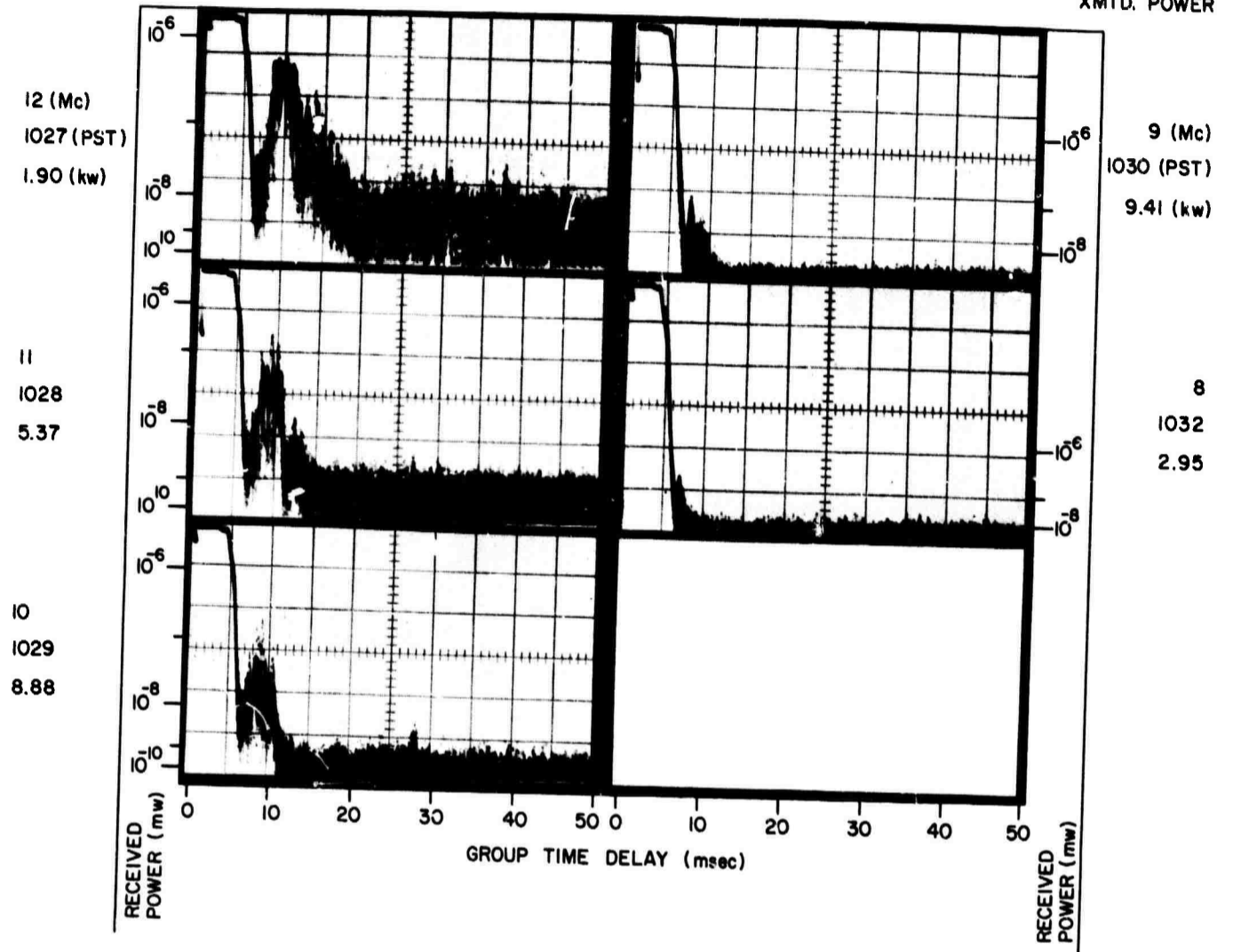

A RECORDS, 23 MAR 1965, 302° BEARING

FREQ.  
TIME  
XMTD. POWER

FREQ.  
TIME  
XMTD. POWER

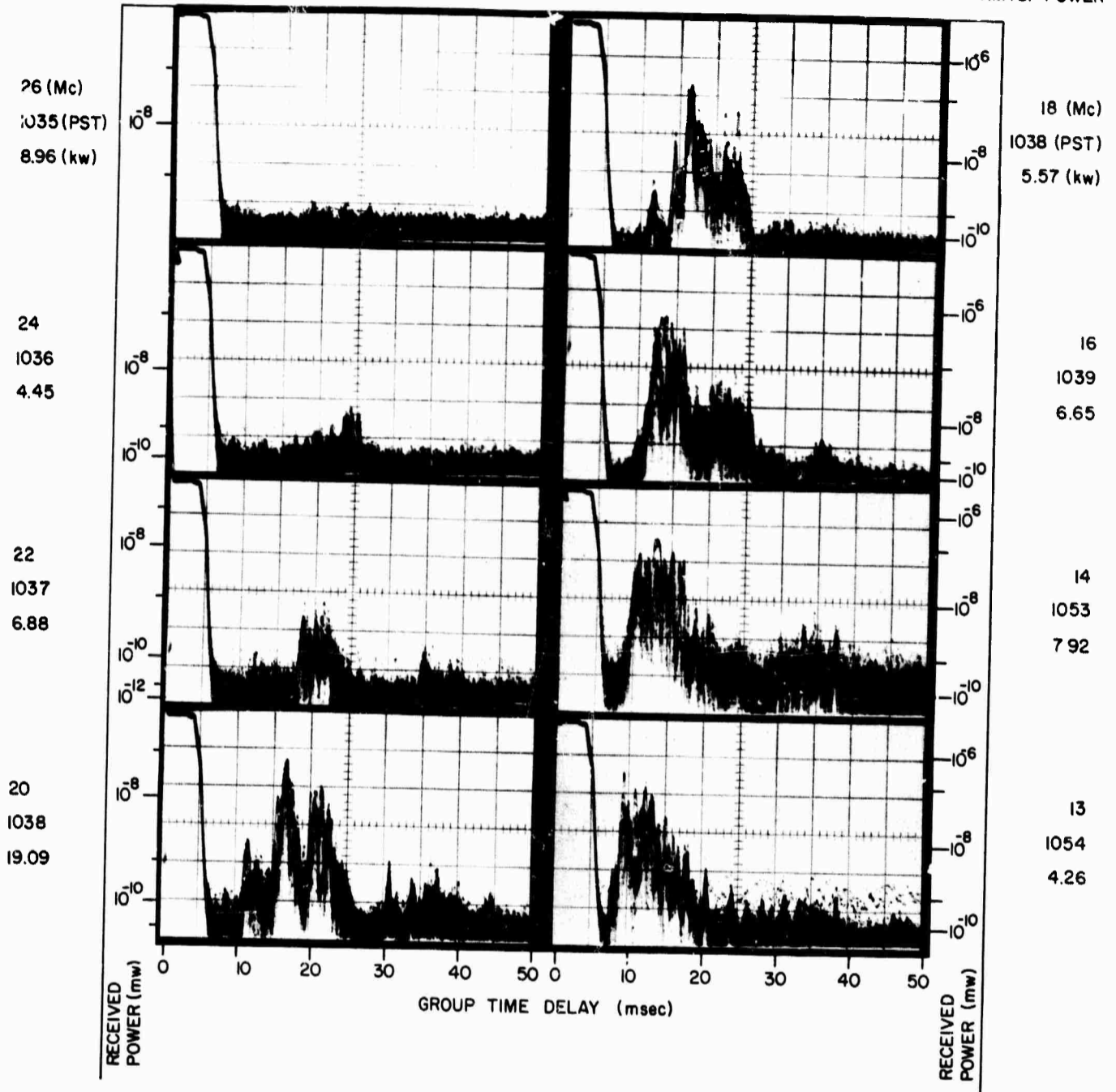

A RECORDS, 23 MAR 1965, 302° BEARING

FREQ.  
TIME  
XMTD. POWER

FREQ.  
TIME  
XMTD. POWER

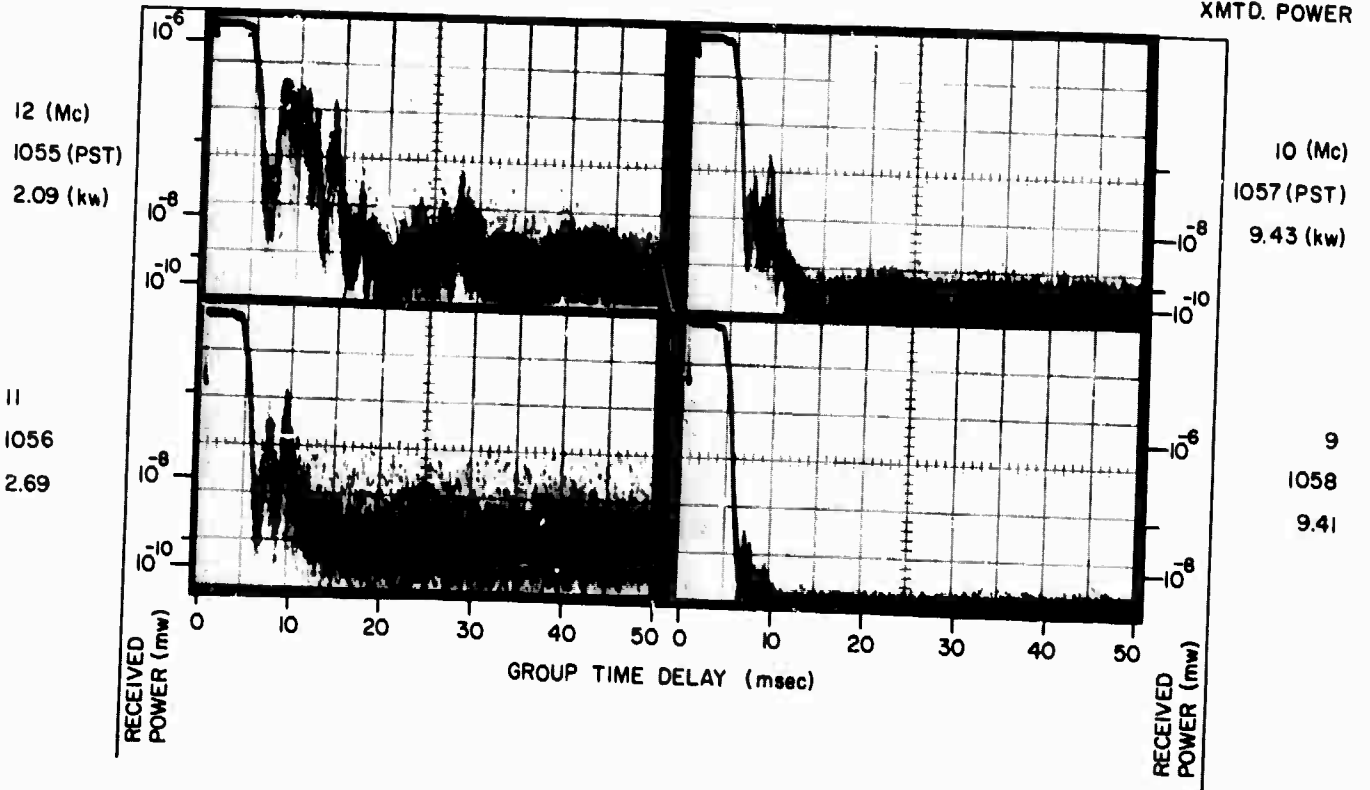

A RECORDS, 23 MAR 1965, 302° BEARING

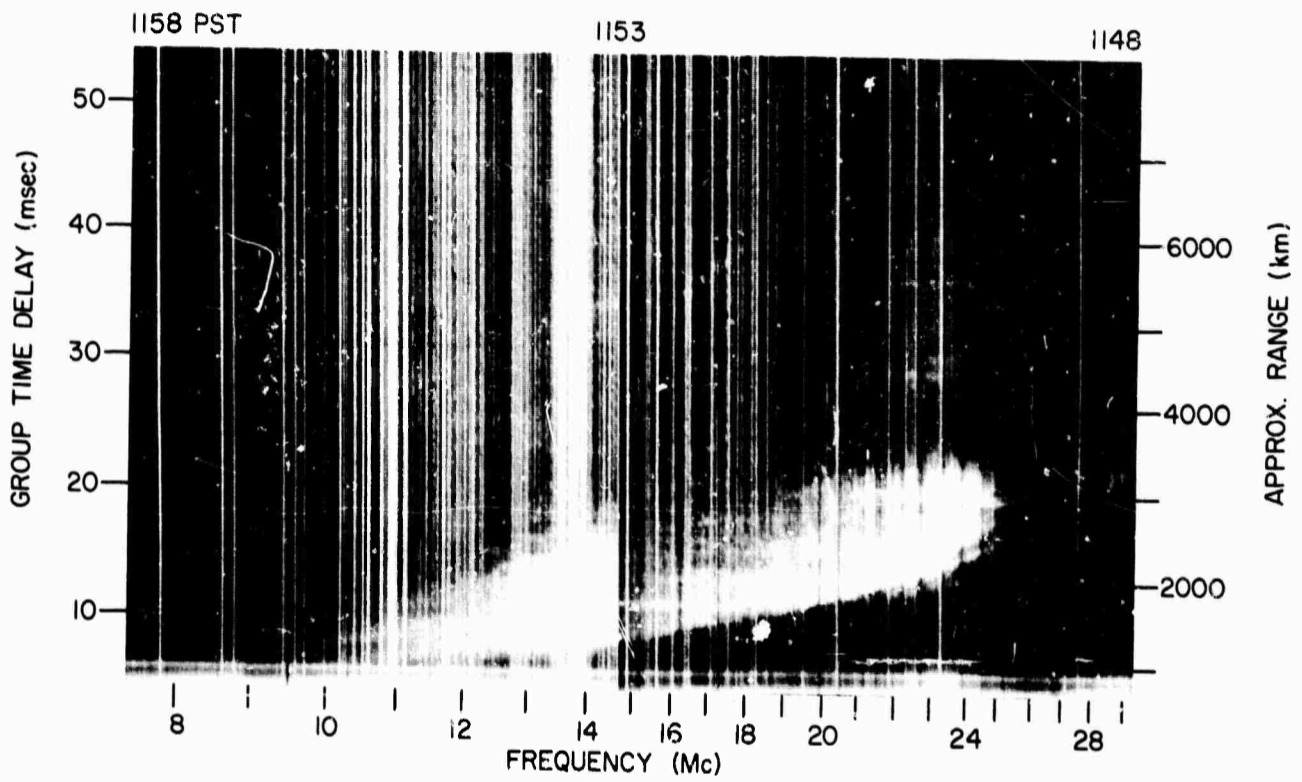
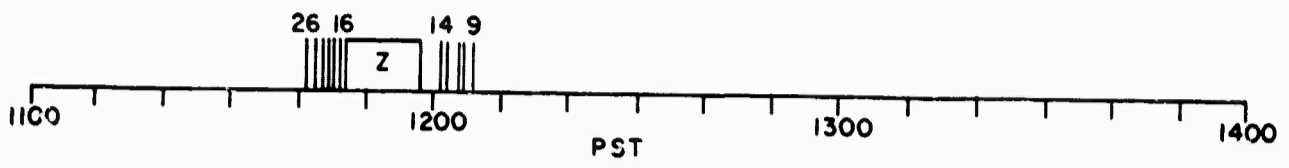

Z RECORD, 23 MAR 1965, 302° BEARING

FREQ.  
TIME  
XMTD. POWER

FREQ.  
TIME  
XMTD. POWER

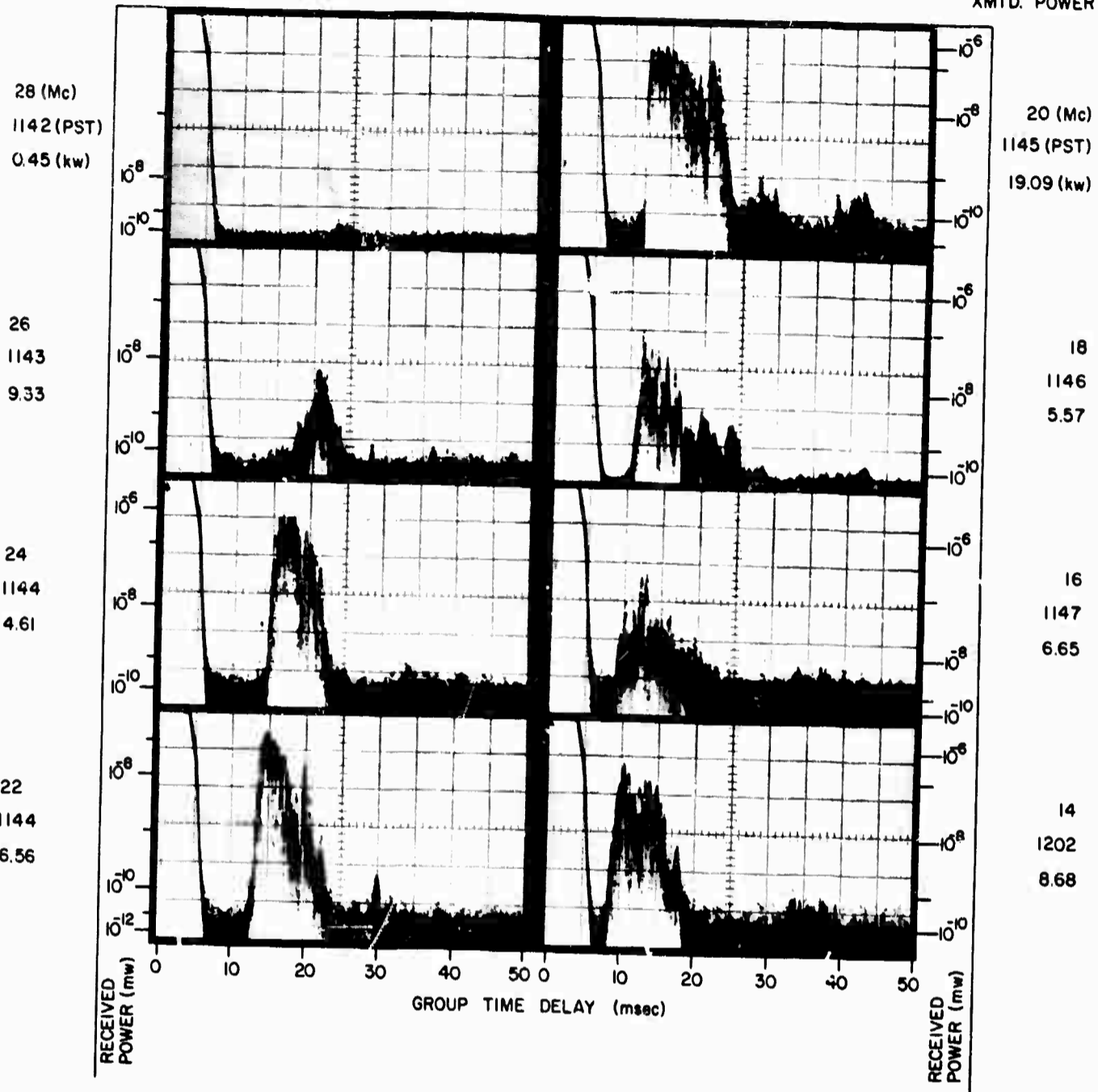

A RECORDS, 23 MAR 1965, 302° BEARING

FREQ.  
TIME  
XMTD. POWER

FREQ.  
TIME  
XMTD. POWER

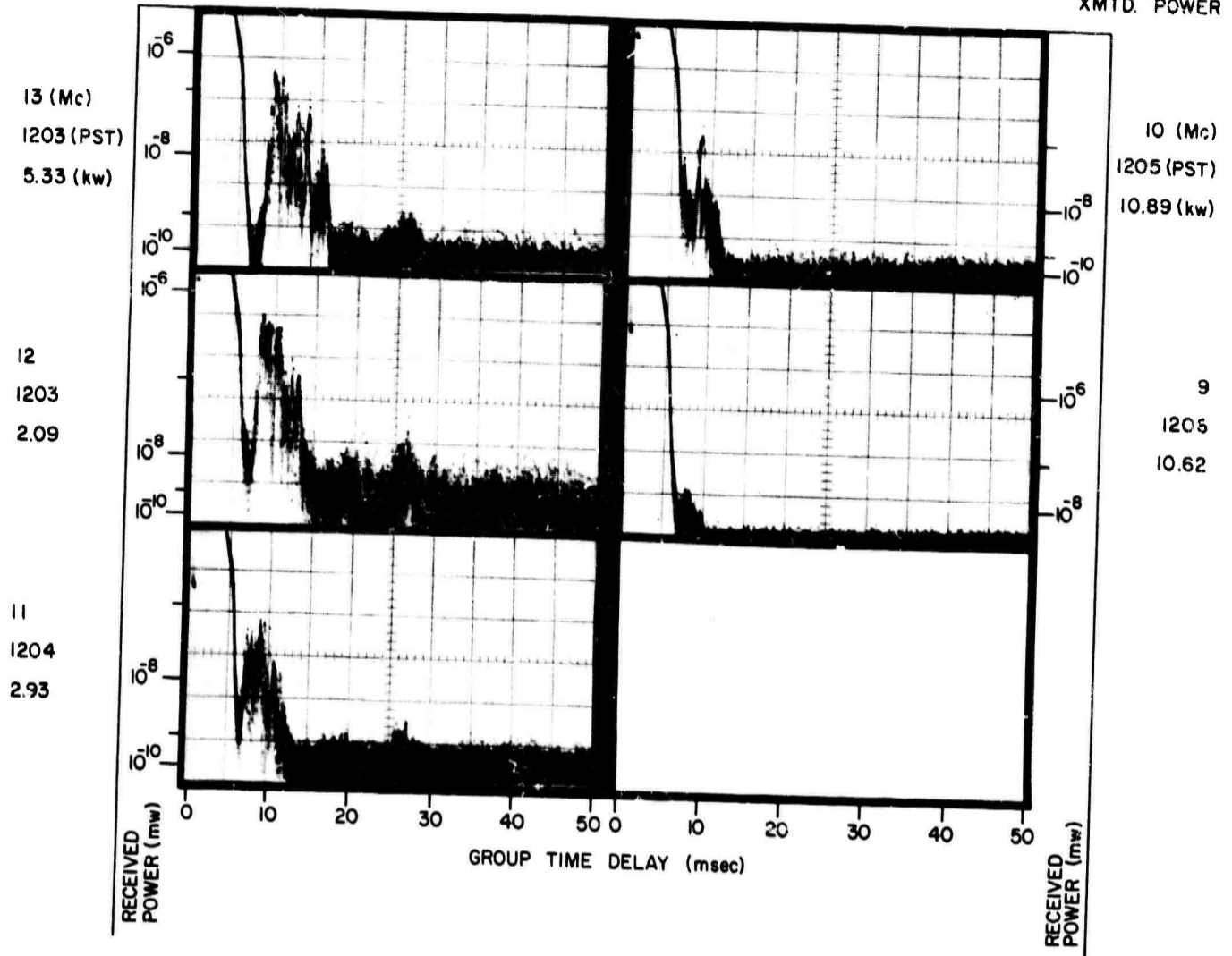

A RECORDS, 23 MAR 1965, 302° BEARING

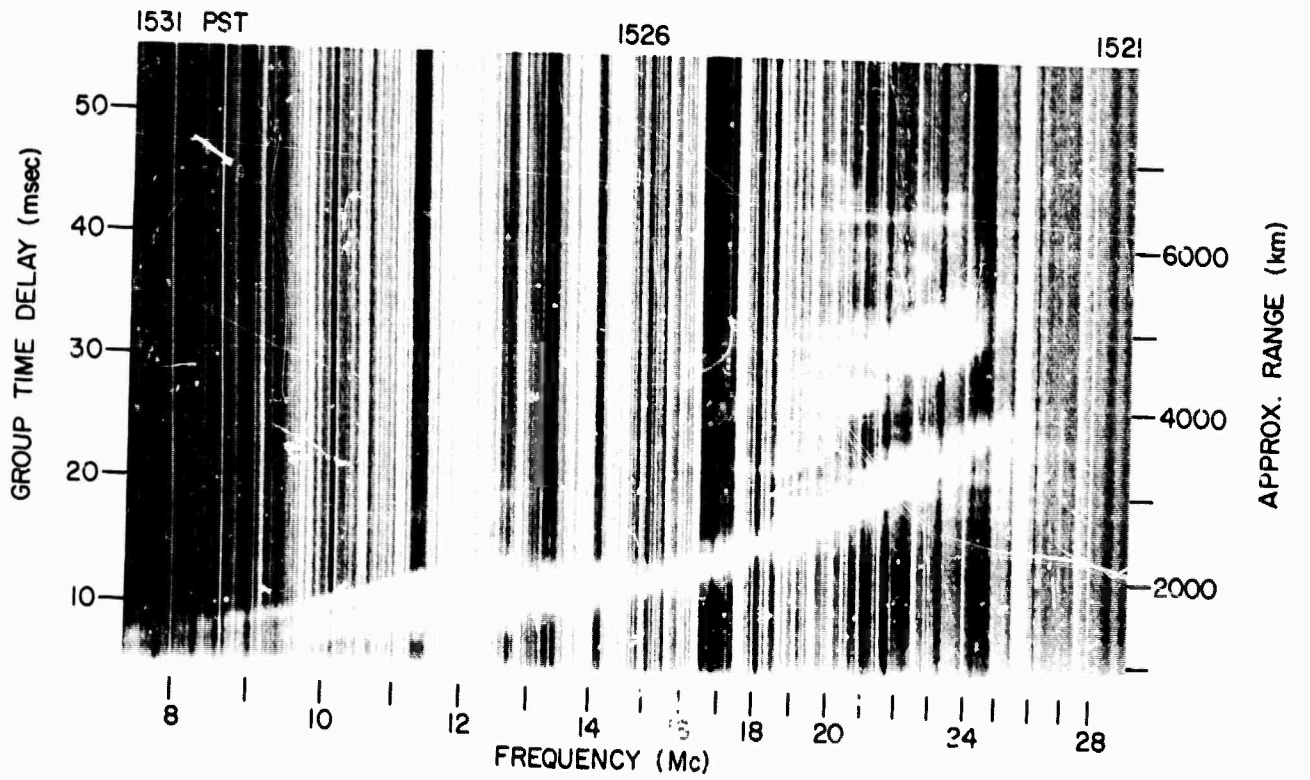
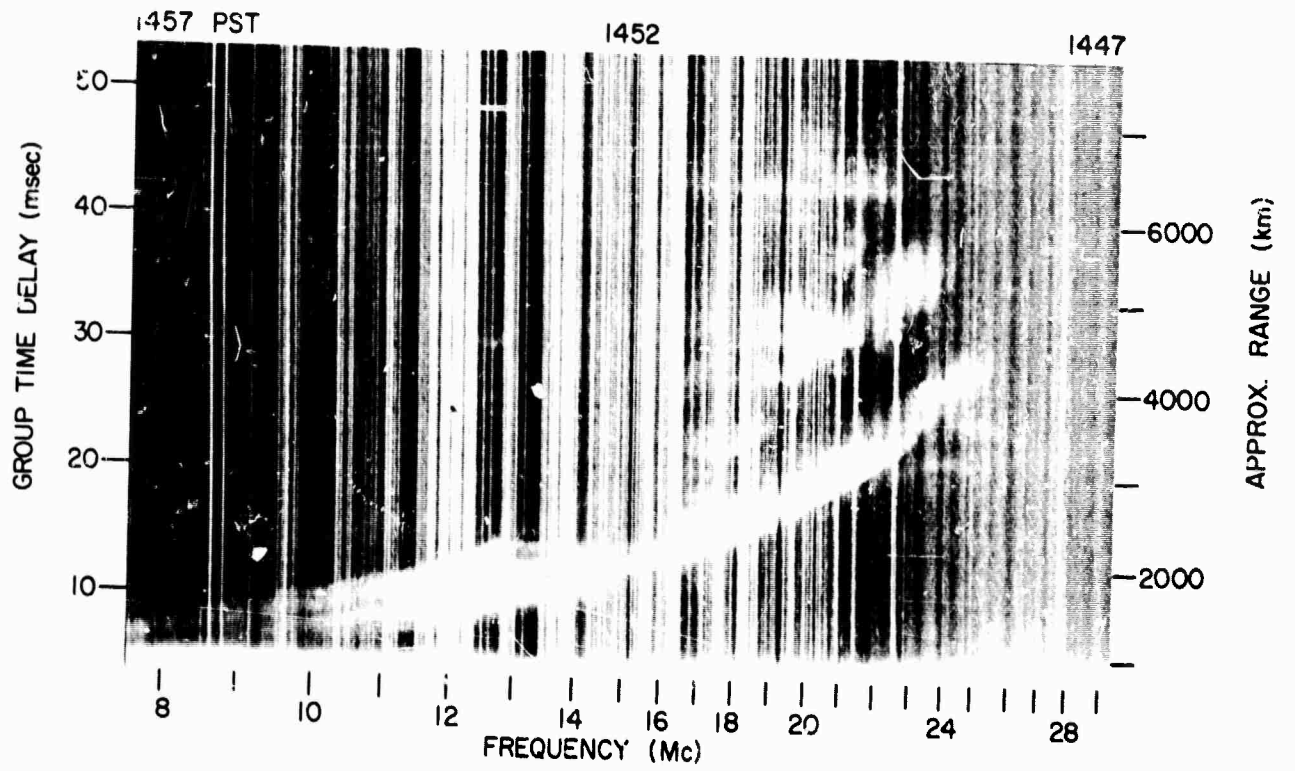
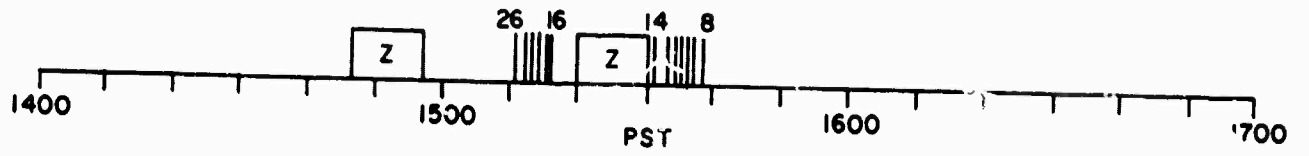

Z RECORDS, 12 APR 1965, 122° BEARING

FREQ.  
TIME  
XMTD. POWER

FREQ.  
TIME  
XMTD. POWER

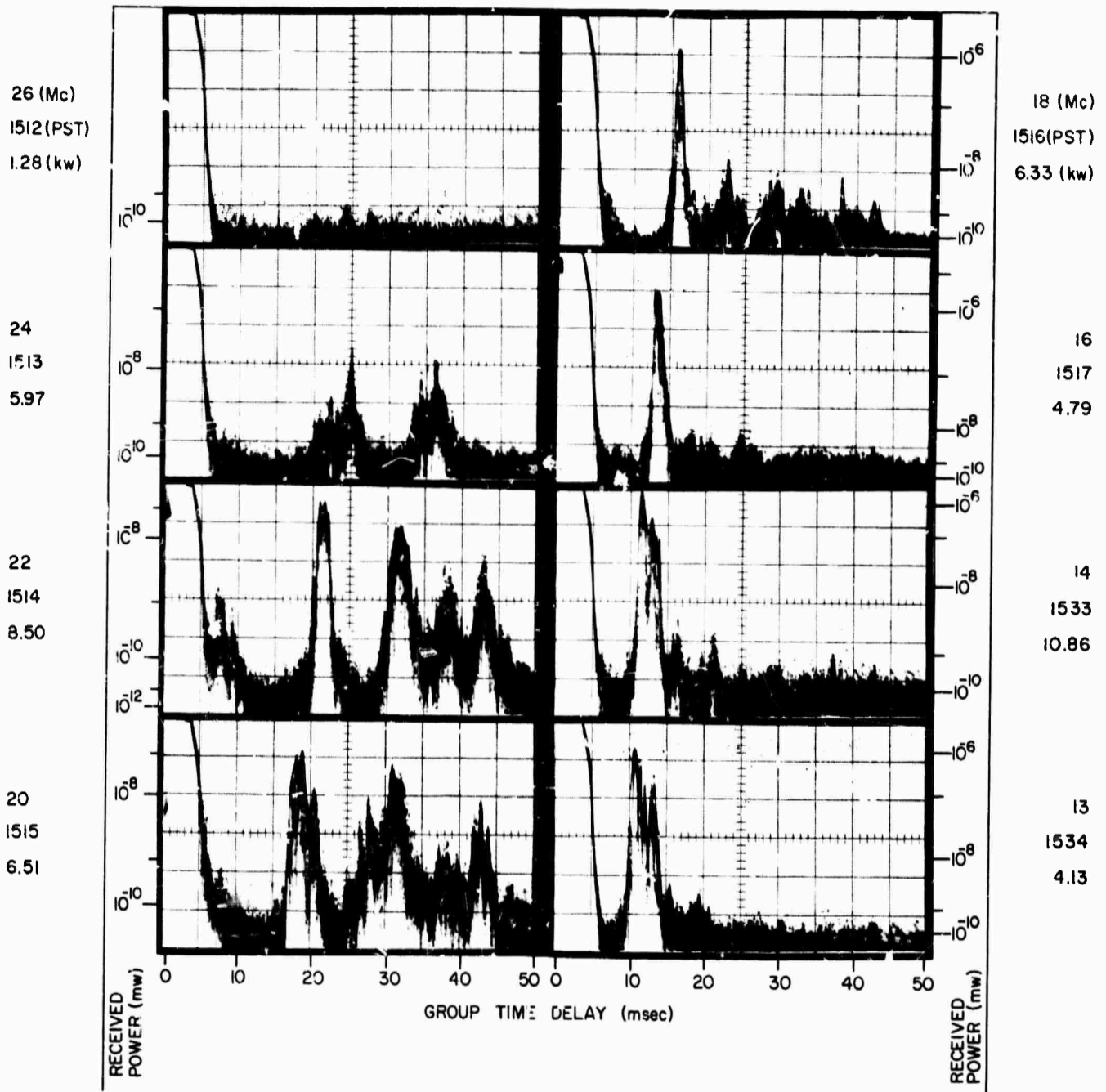

A RECORDS, 12 APR 1965, 122° BEARING

FREQ.  
TIME  
XMTD. POWER

FREQ.  
TIME  
XMTD. POWER

12 (Mc)  
1535 (PST)  
3.24 (kw)

9 (Mc)  
1538 (PST)  
6.66 (kw)

11  
1536  
6.12

8  
1539  
4.78

10  
1537  
8.29

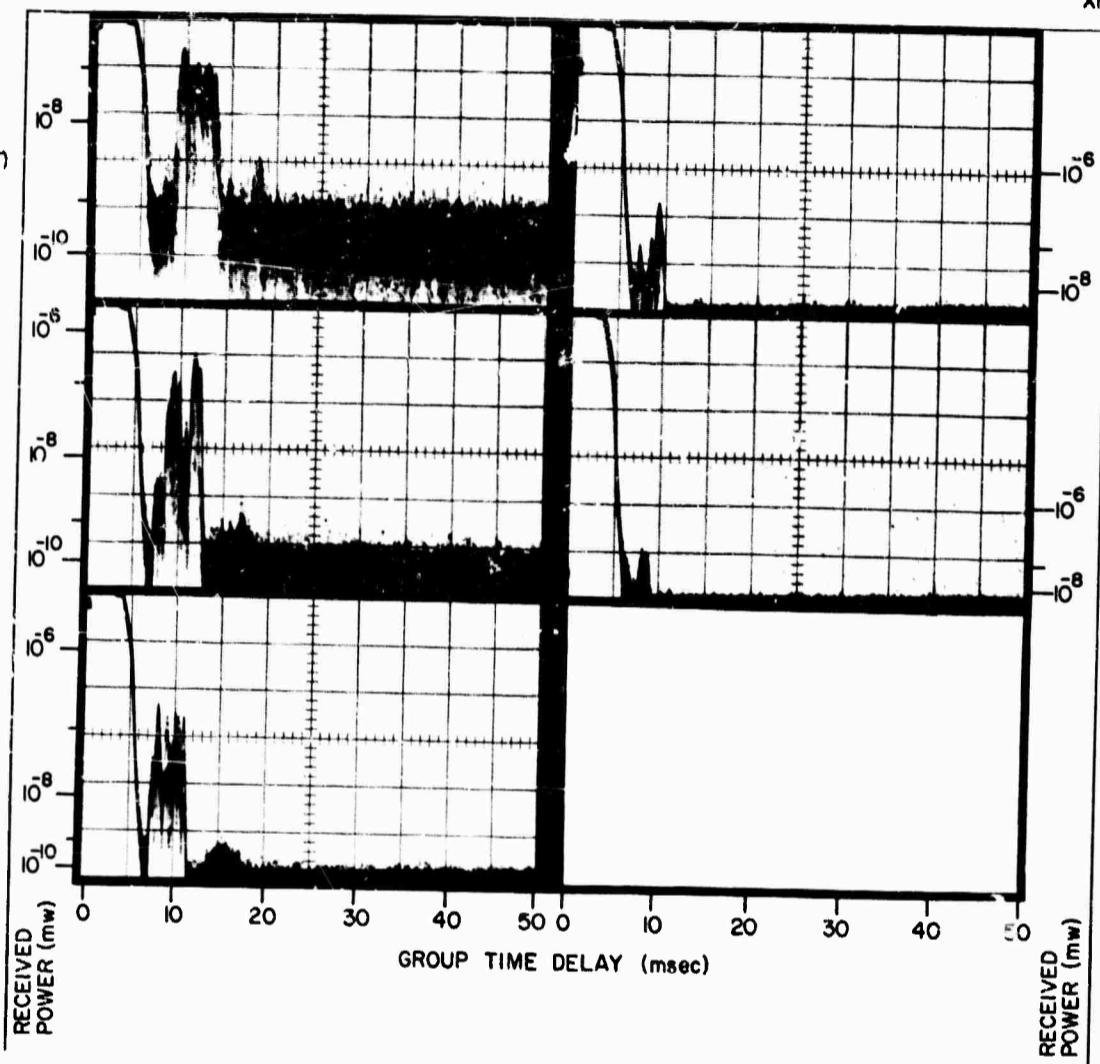

A RECORDS, 12 APR 1965, 122° BEARING

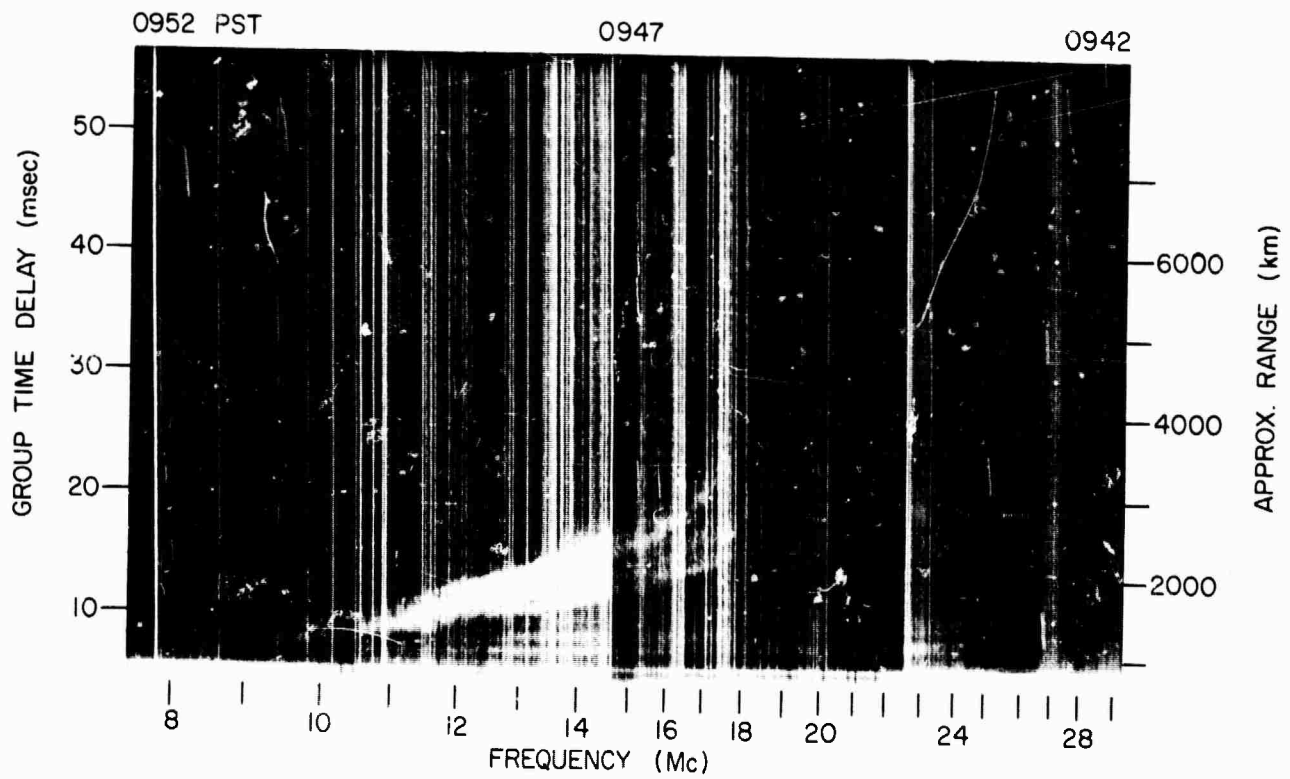
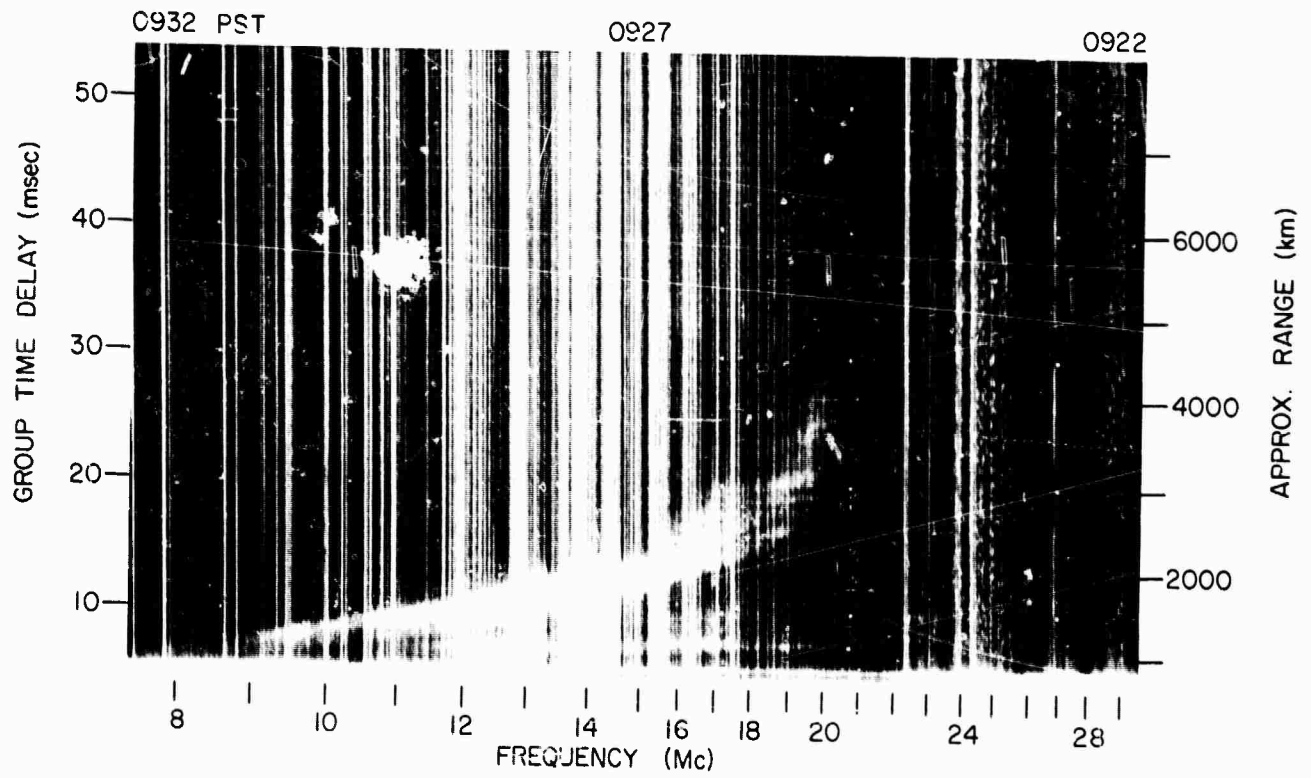
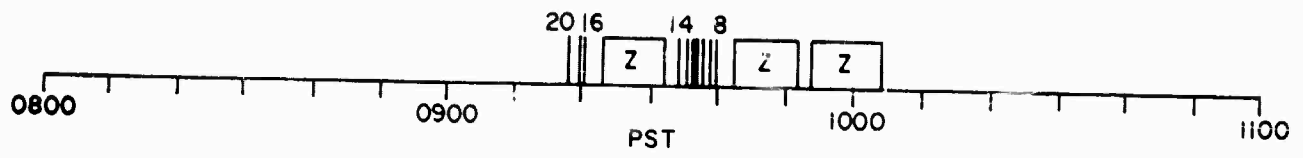

Z RECORDS, 14 APR 1965, 122° BEARING

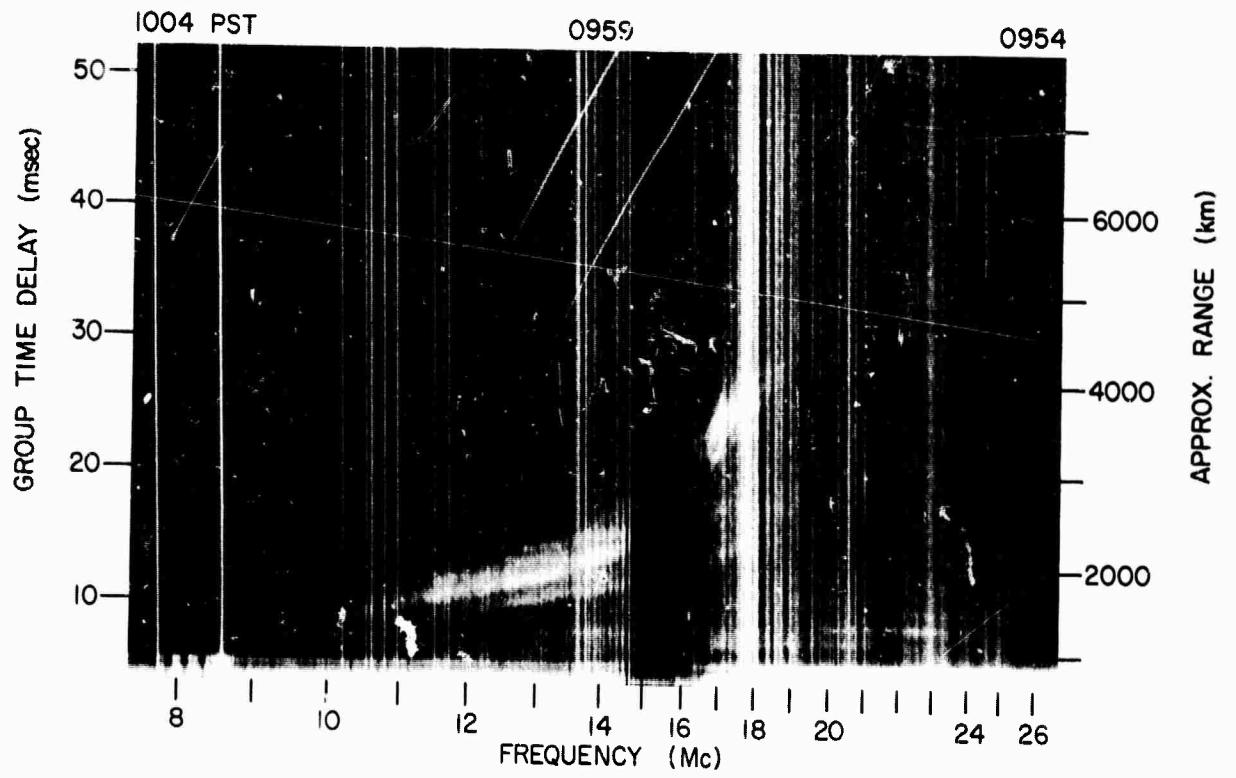

Z RECORD, 14 APR 1965, 122° BEARING

FREQ.  
TIME  
XMTD. POWER

FREQ.  
TIME  
XMTD. POWER

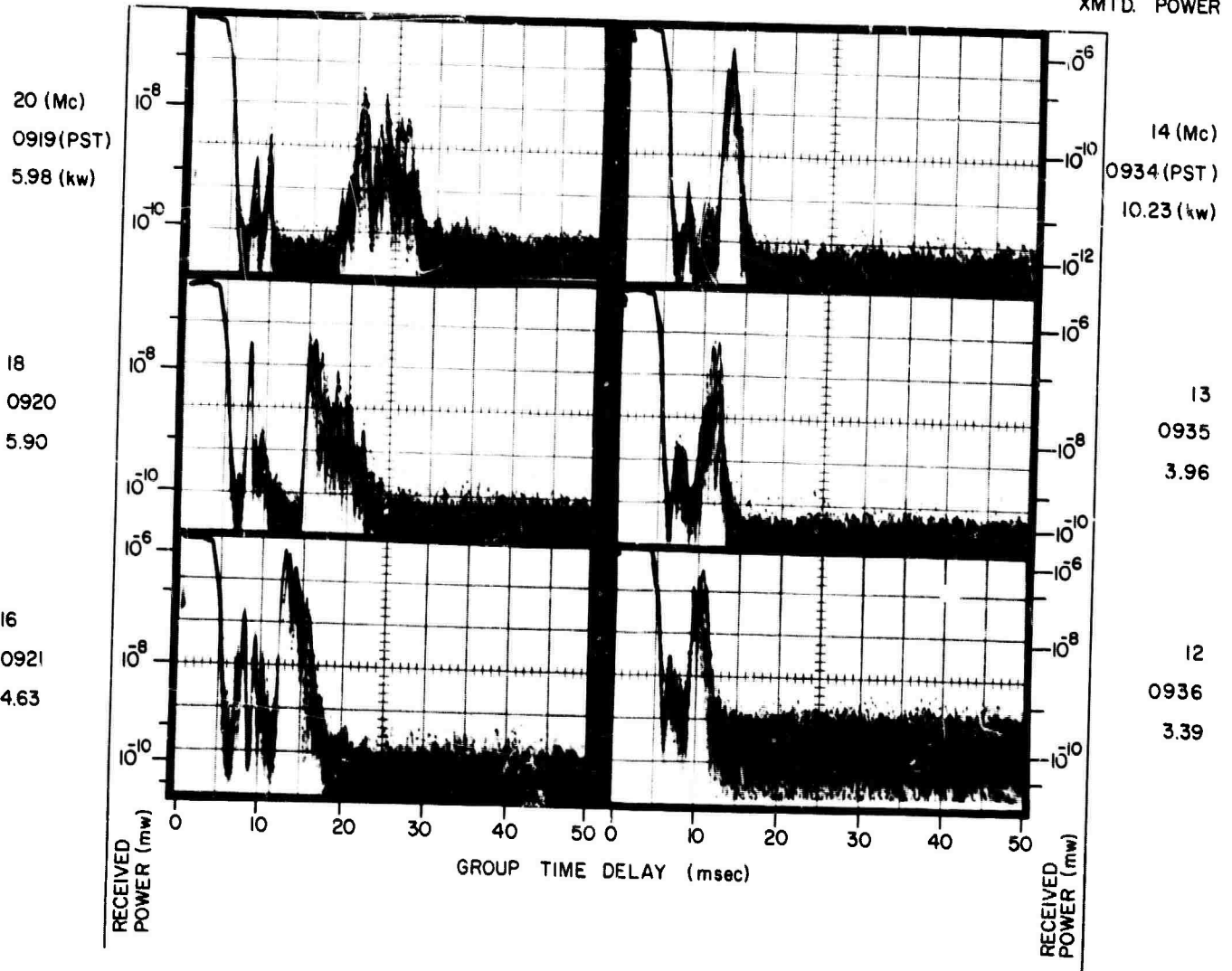

A RECORDS, 14 APR 1965, 122° BEARING

FREQ.  
TIME  
XMTD. POWER

FREQ.  
TIME  
XMTD. POWER

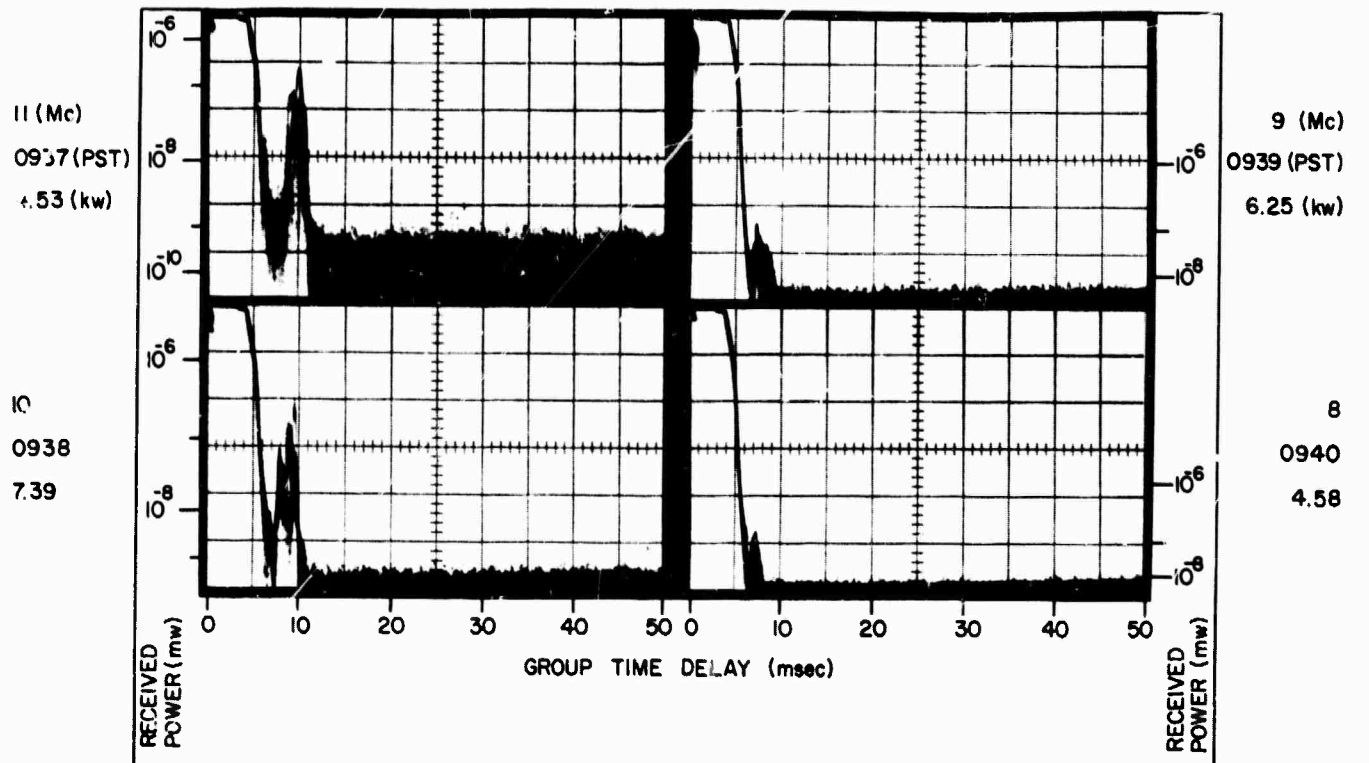

A RECORDS, 14 APR 1965, 122° BEARING

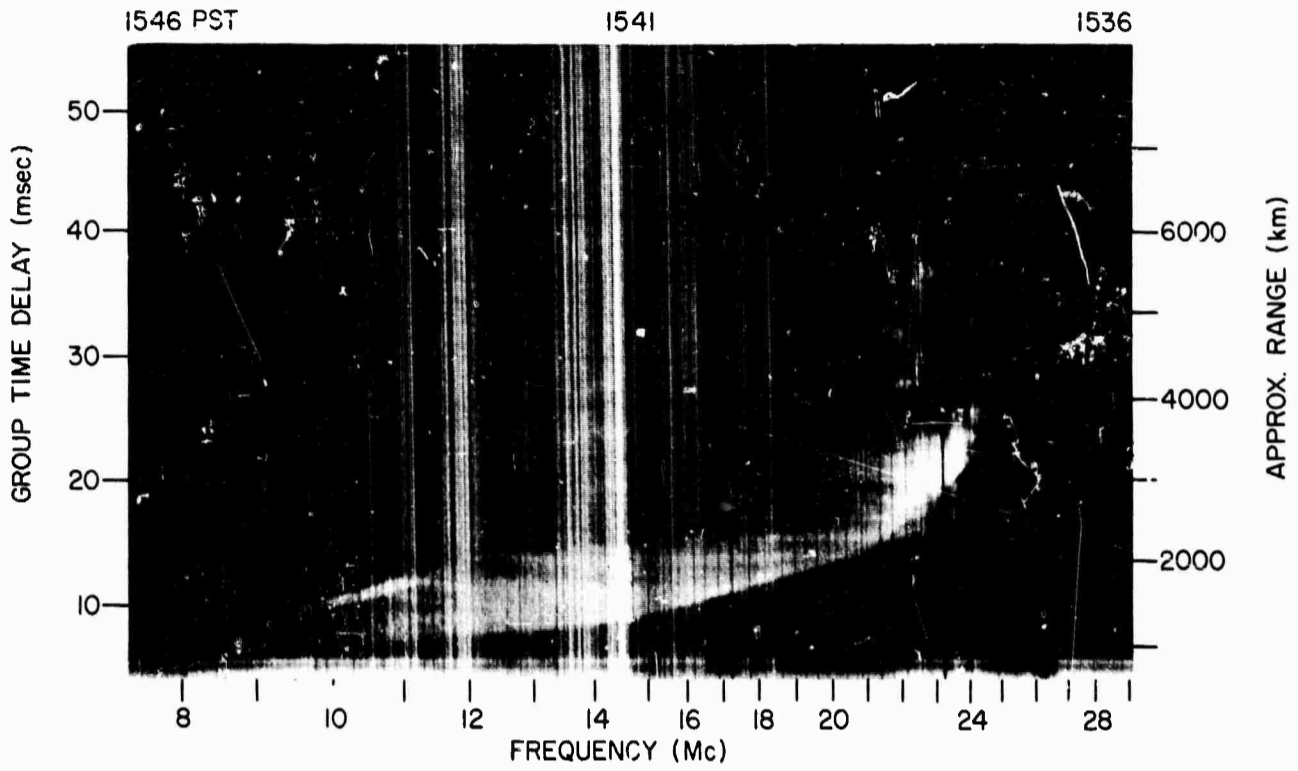
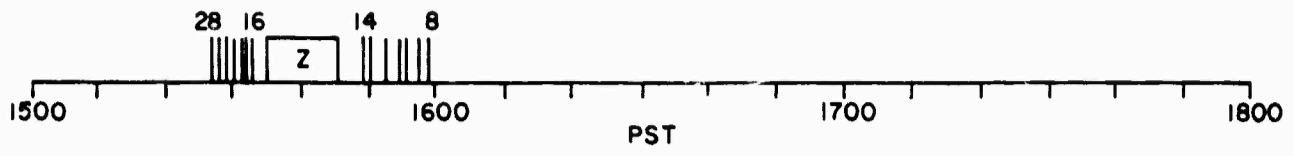

Z RECORD, 14 APR 1965, 122° BEARING

FREQ.  
TIME  
XMTD. POWER

FREQ.  
TIME  
XMTD. POWER

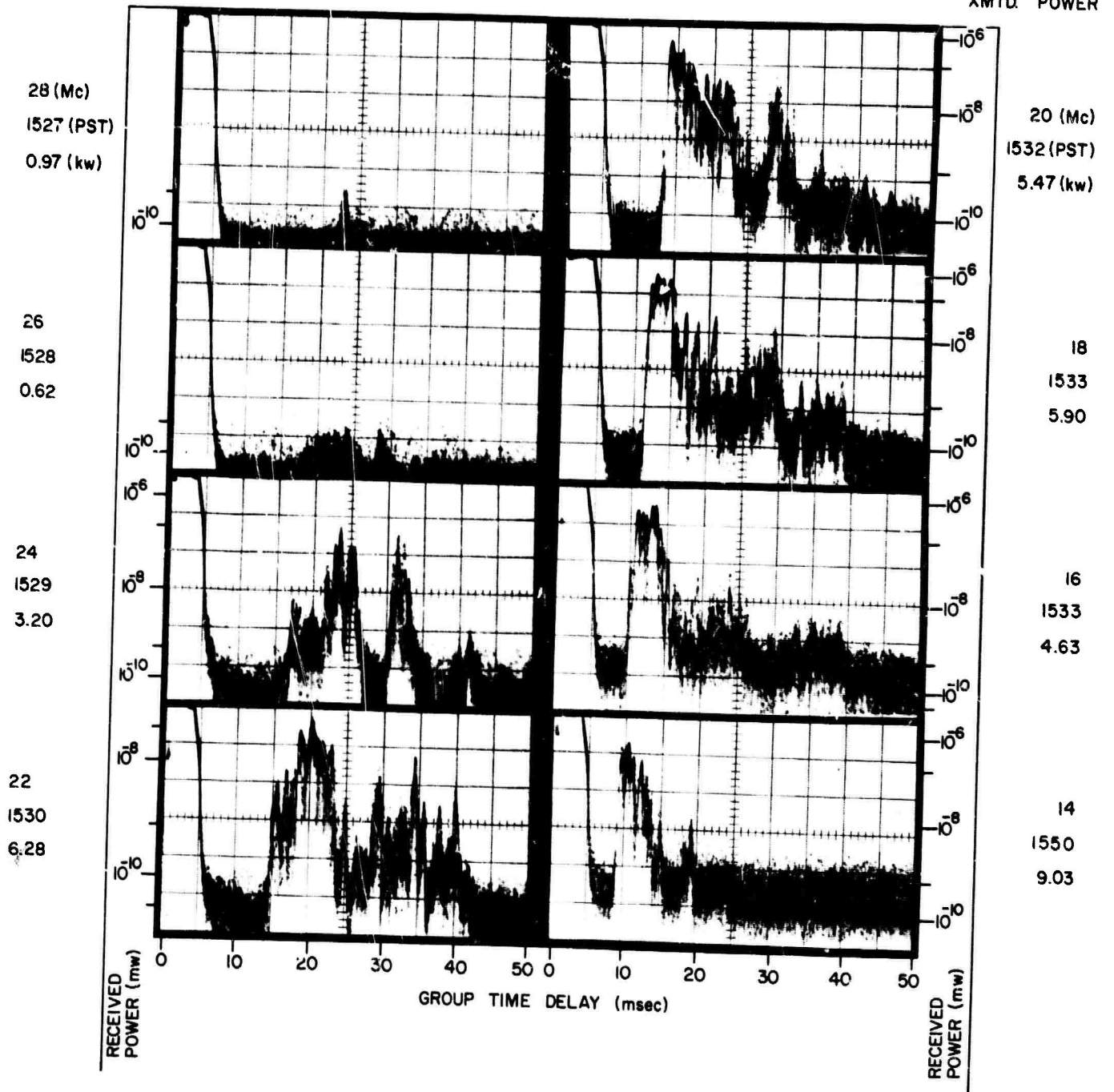

A RECORDS, 14 APR 1965, 122° BEARING

FREQ.  
TIME  
XMTD. POWER

FREQ.  
TIME  
XMTD. POWER

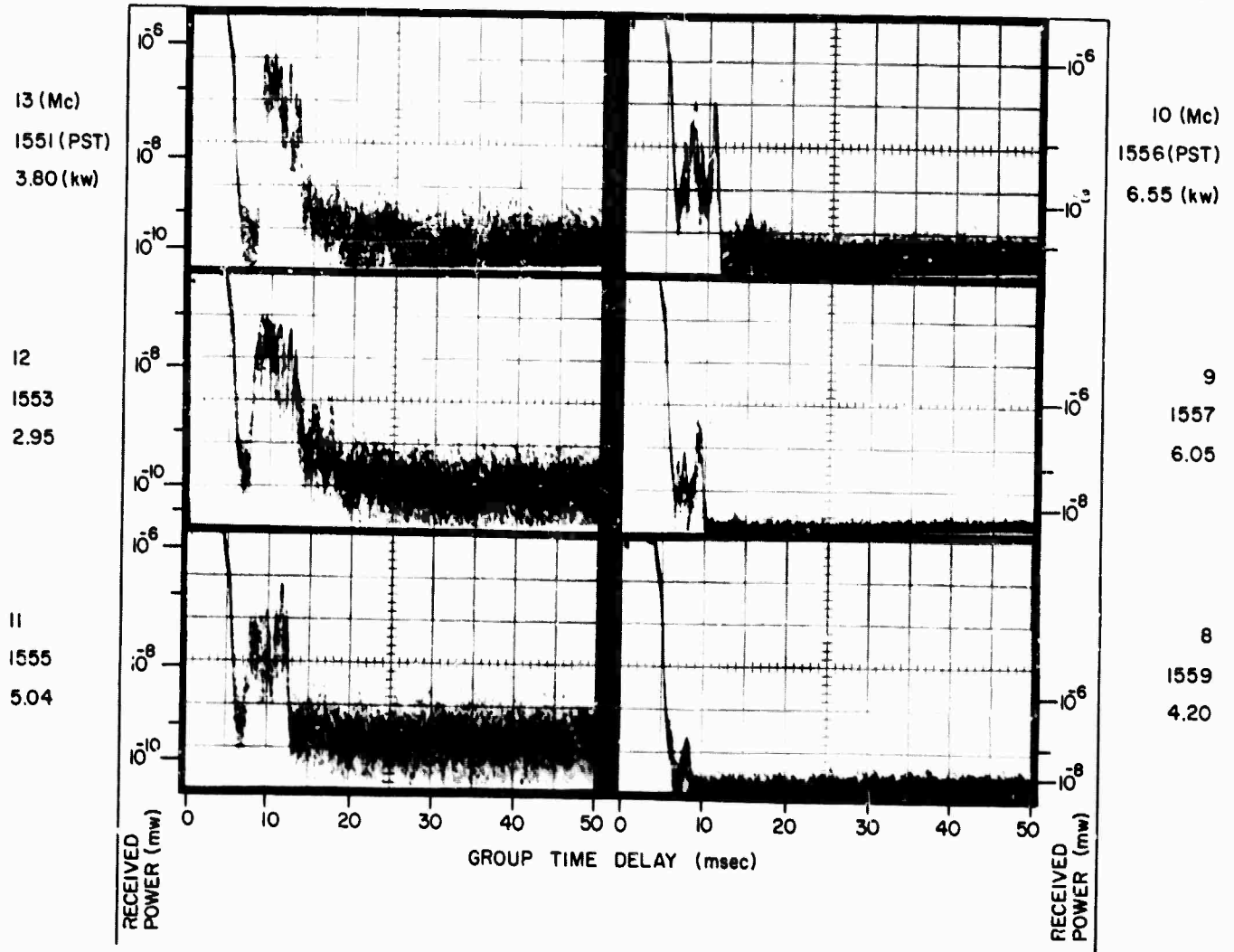

A RECORDS, 14 APR 1965, 122° BEARING

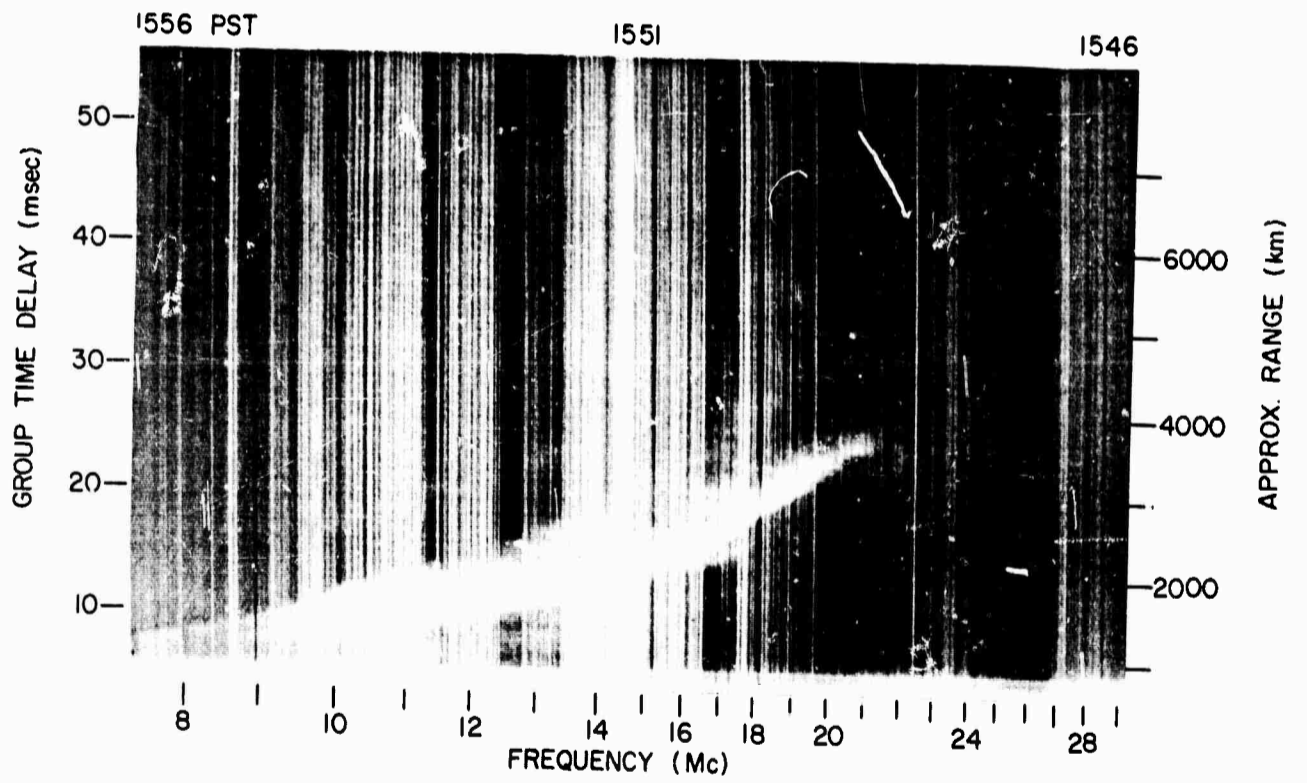
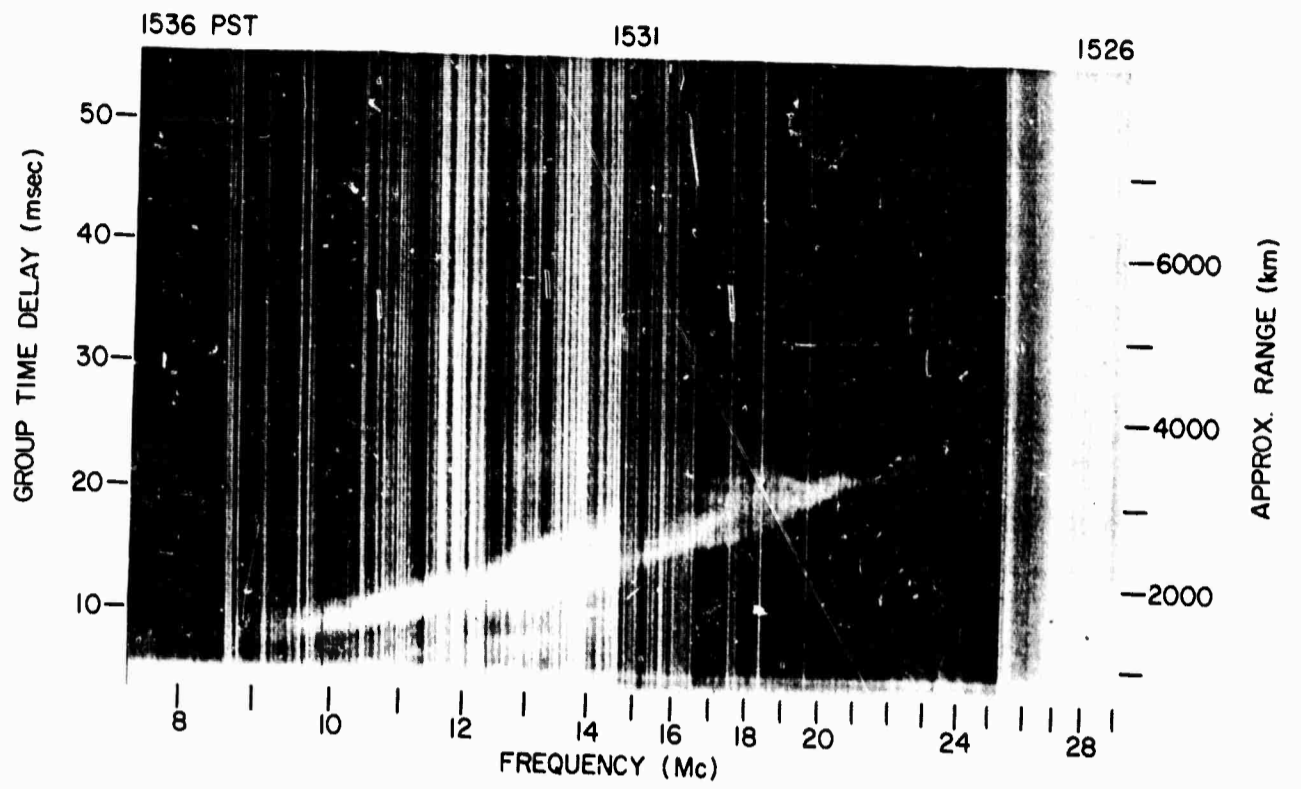
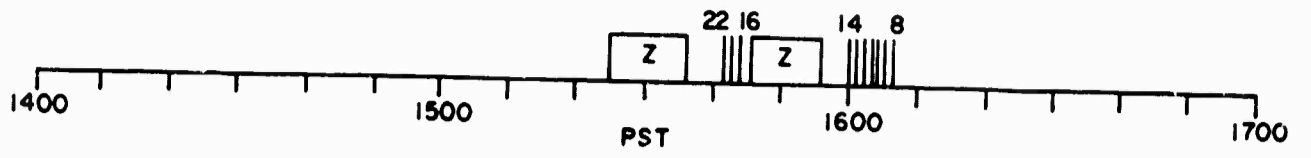

Z RECORDS, 22 APR 1965, 122° BEARING

FREQ.  
TIME  
XMTD. POWER

FREQ.  
TIME  
XMTD. POWER

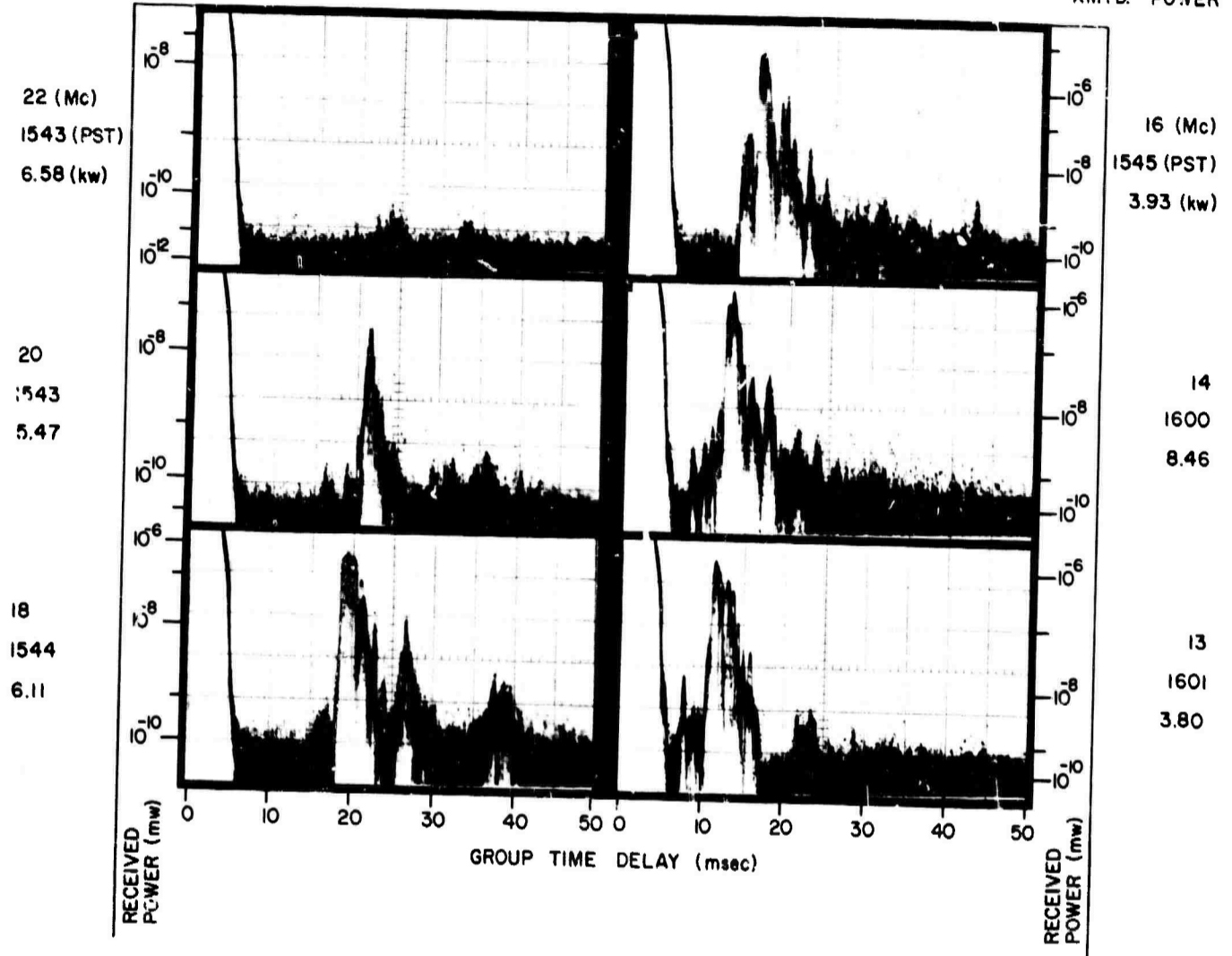

A RECORDS, 22 APR 1965, 122° BEARING

FREQ.  
TIME  
XMTD. POWER

FREQ.  
TIME  
XMTD. POWER

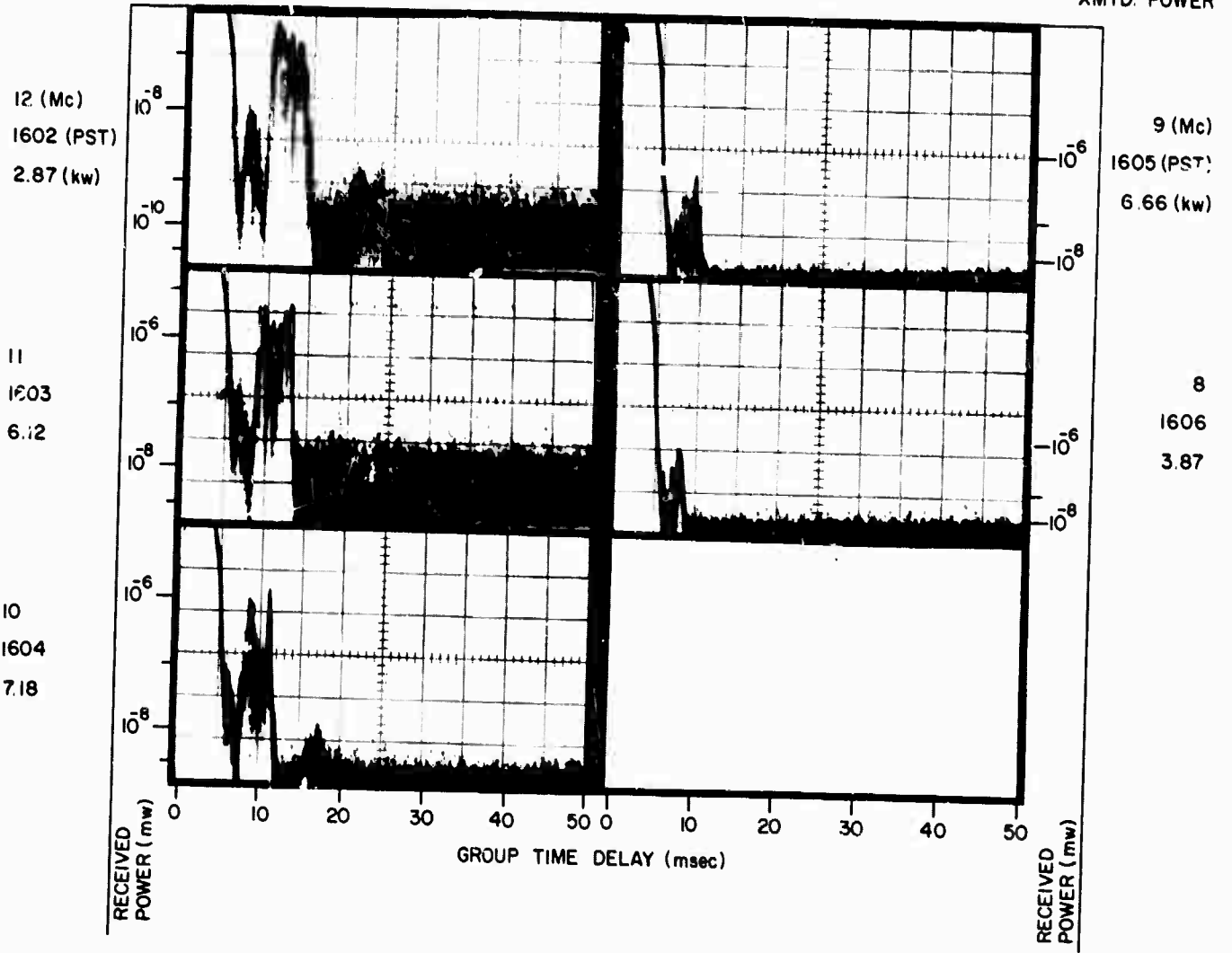

A RECORDS, 22 APR 1965, 122° BEARING



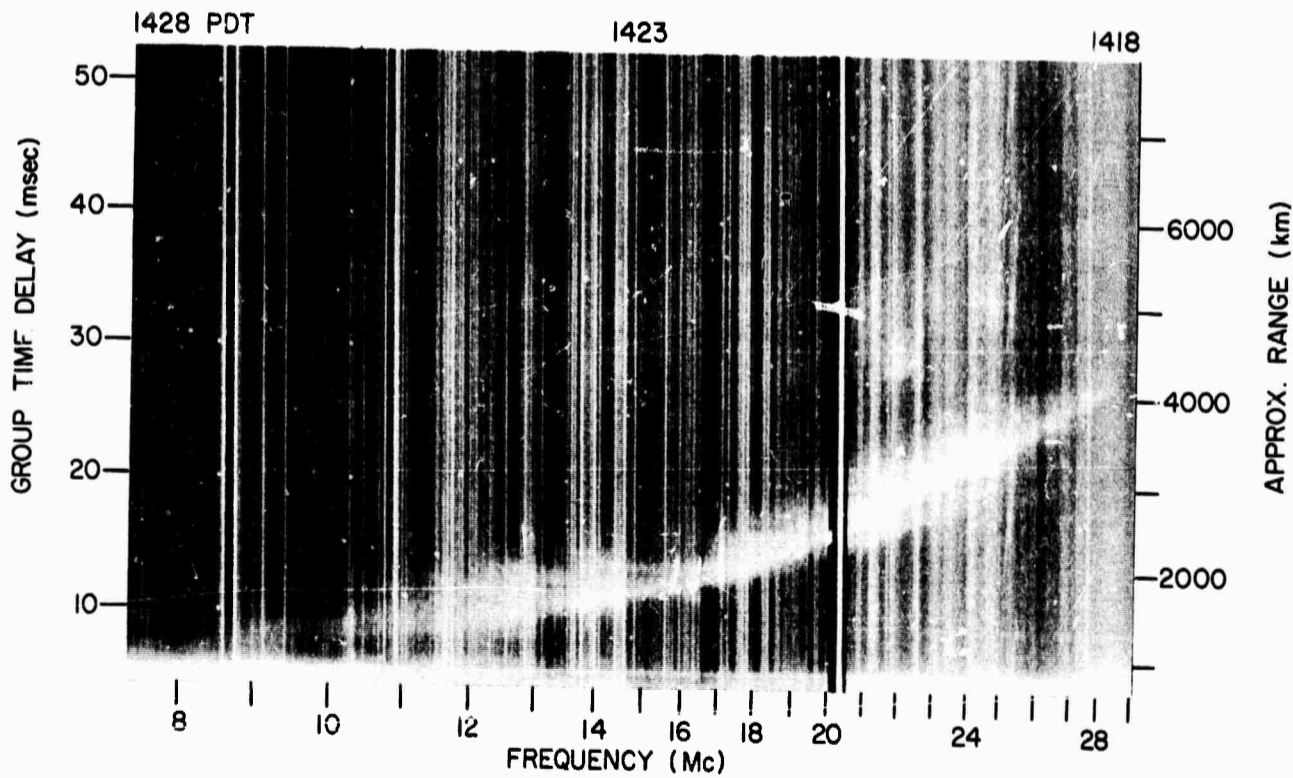
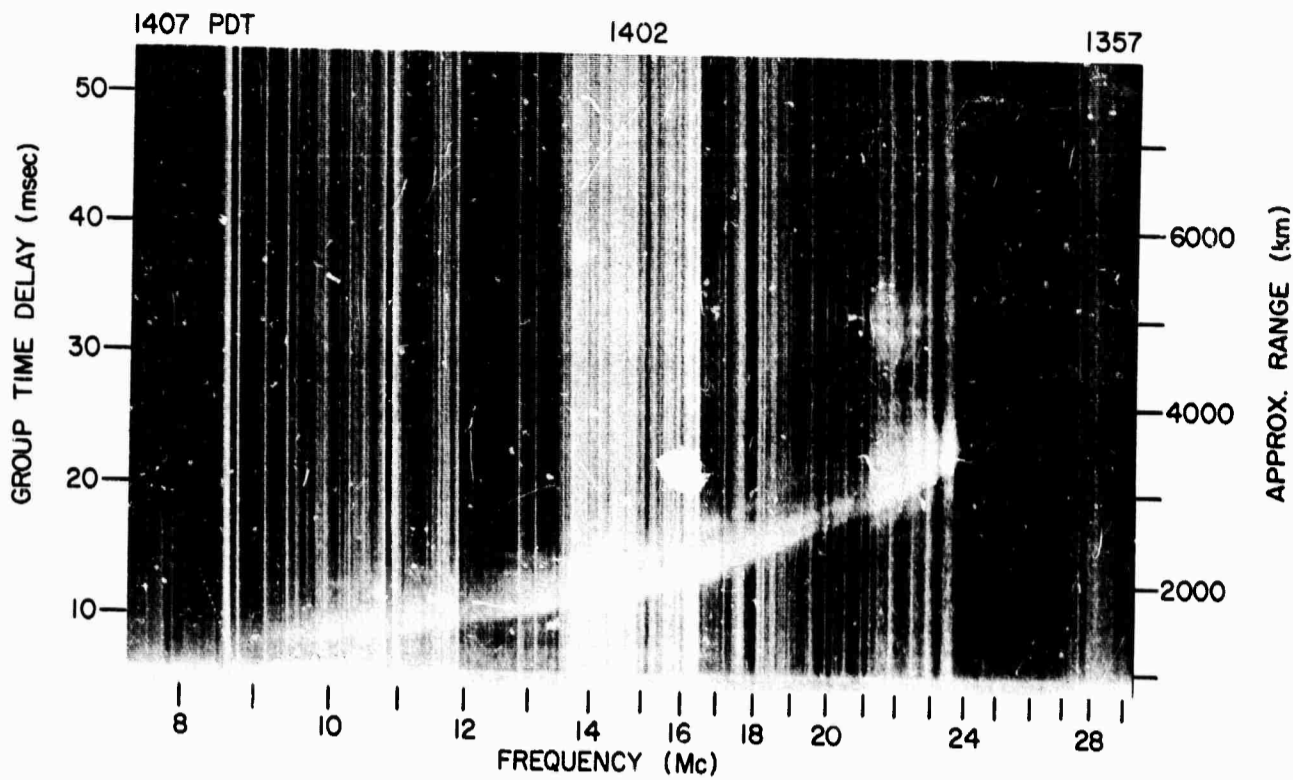
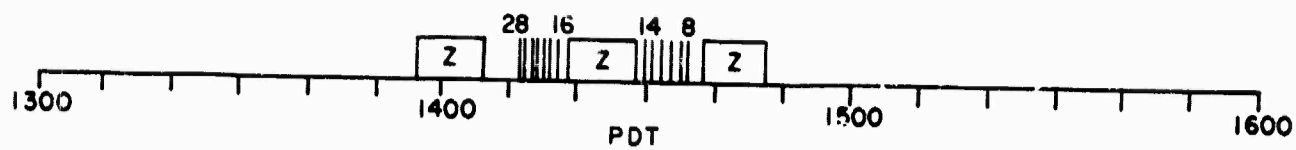

Z RECORDS, 27 APR 1965, 122° BEARING

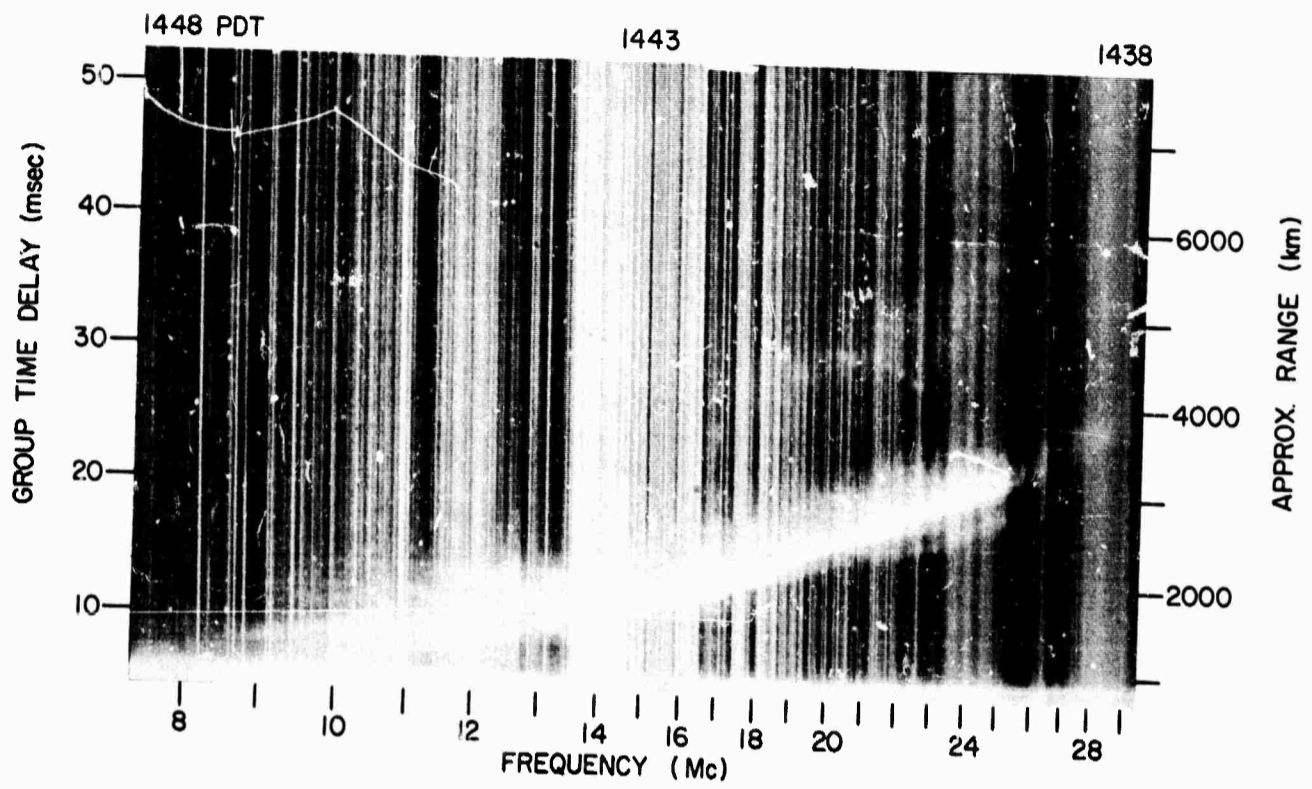

Z RECORD, 27 APR 1965, 122° BEARING

FREQ.  
TIME  
XMTD. POWER

FREQ.  
TIME  
XMTD. POWER

28 (Mc)  
1412 (PDT)  
0.88 (kw)

20 (Mc)  
1416 (PDT)  
5.47 (kw)

26  
1413  
0.12

19  
1416  
4.86

24  
1414  
3.23

16  
1417  
4.46

22  
1415  
5.71

14  
1430  
8.46

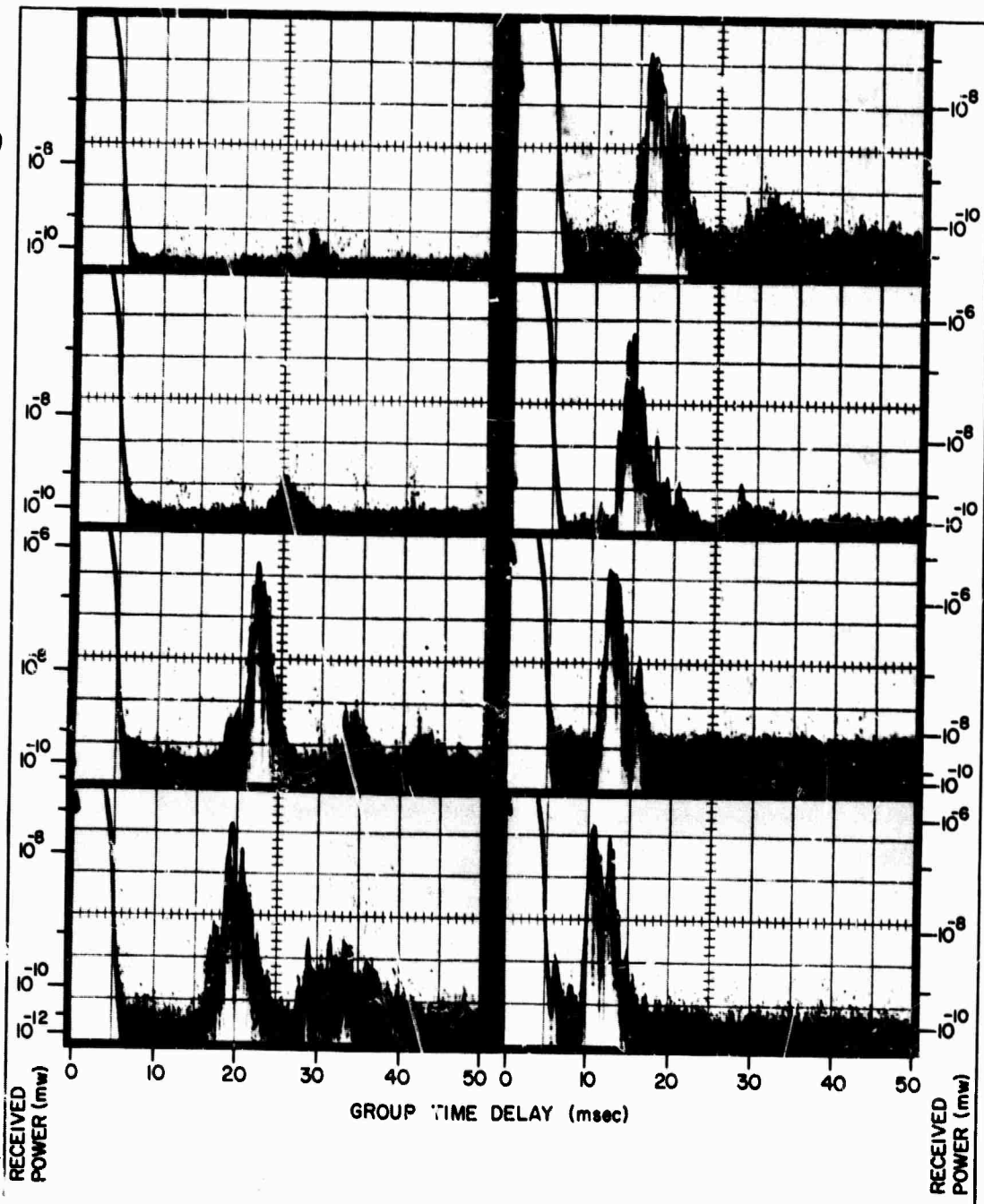

A RECORDS, 27 APR 1965, 122° BEARING

FREQ.  
TIME  
XMTD. POWER

FREQ.  
TIME  
XMTD. POWER

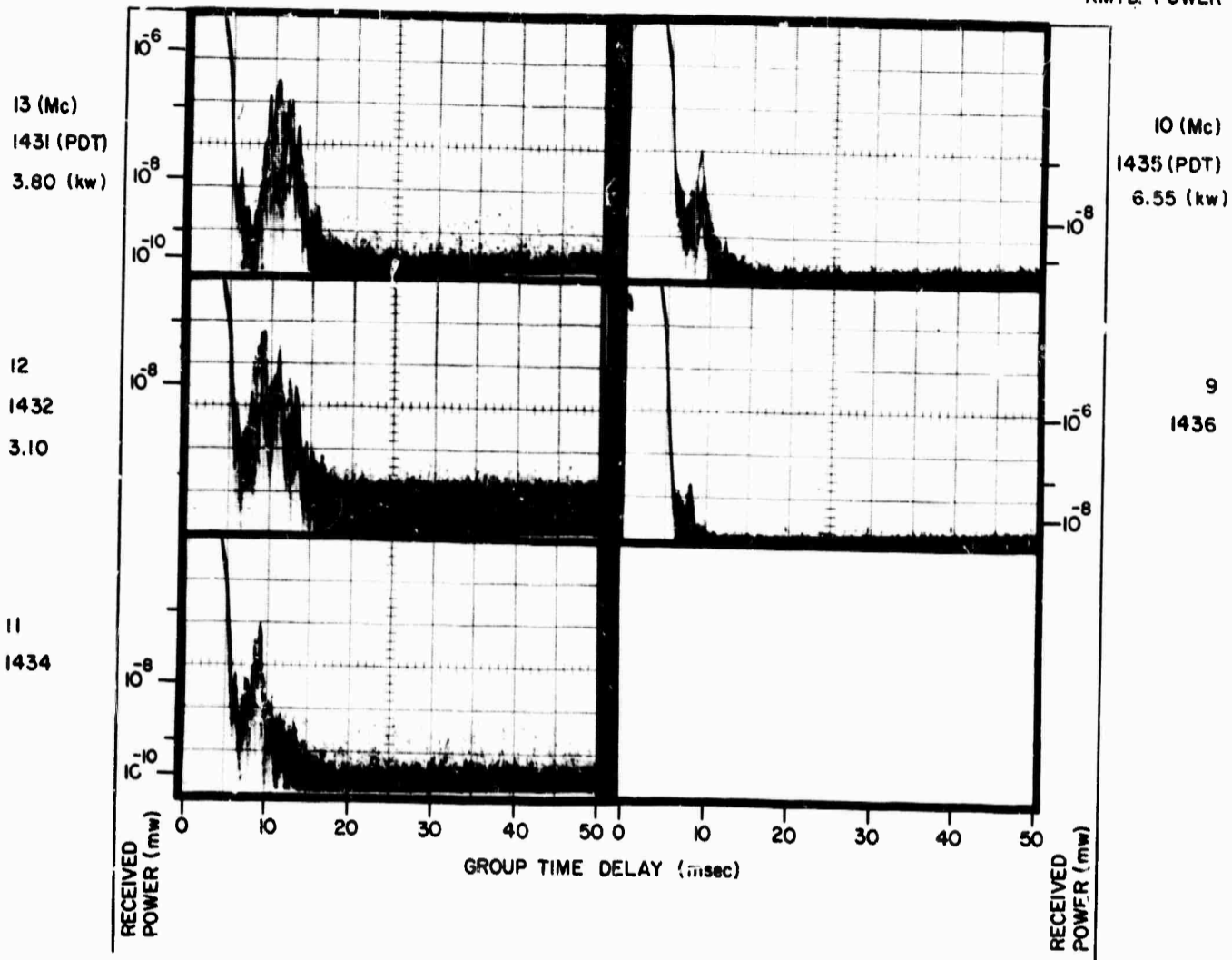

A RECORDS, 27 APR 1965, 122° BEARING

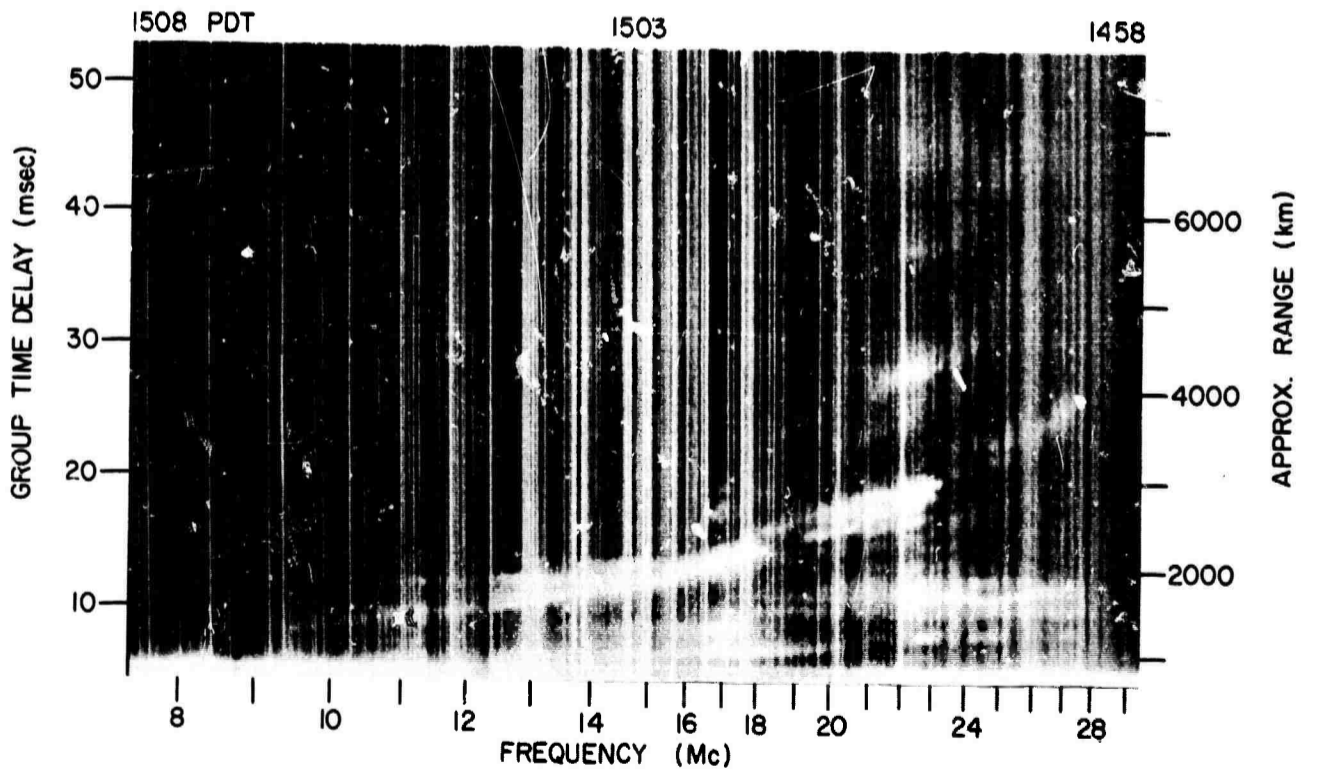
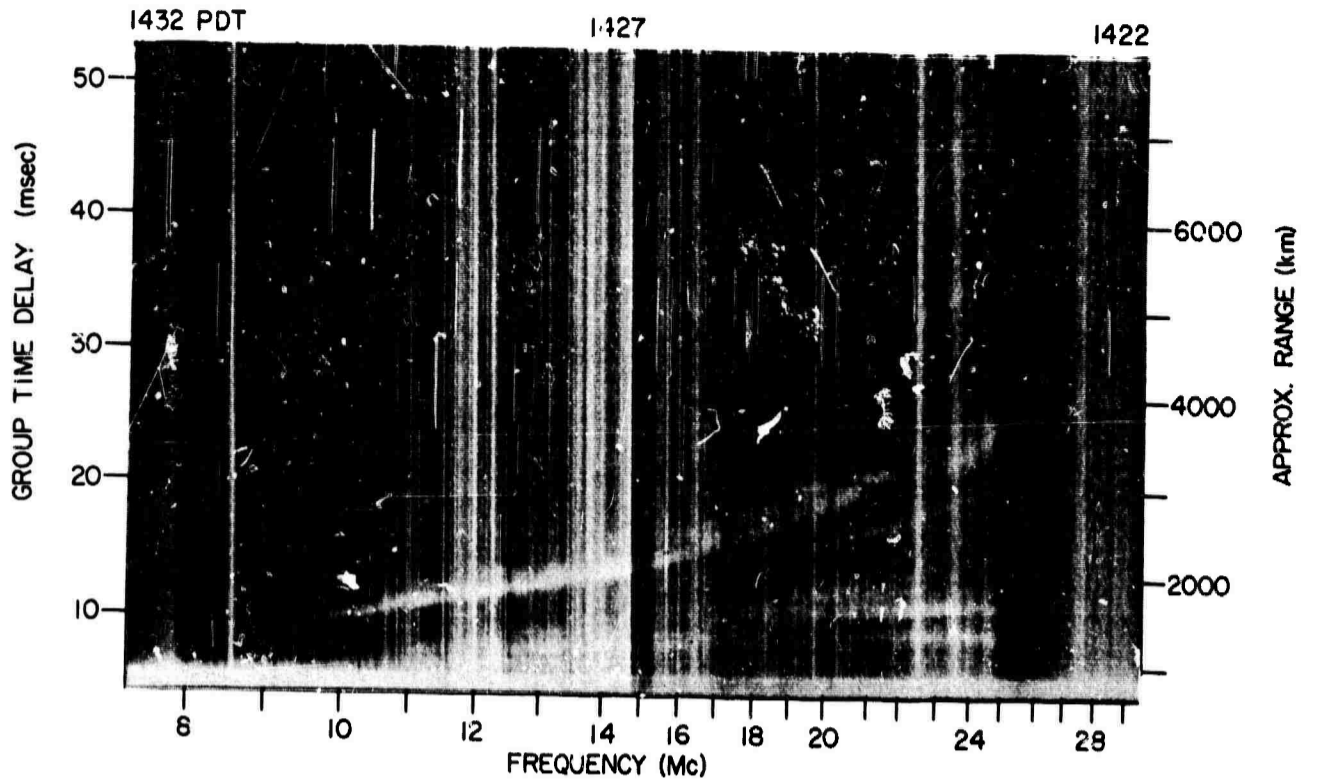
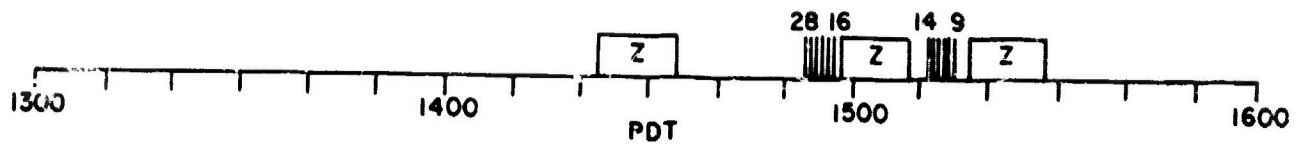

Z RECORDS, 28 APR 1965, 122° BEARING



FREQ.  
TIME  
XMTD. POWER

FREQ.  
TIME  
XMTD. POWER

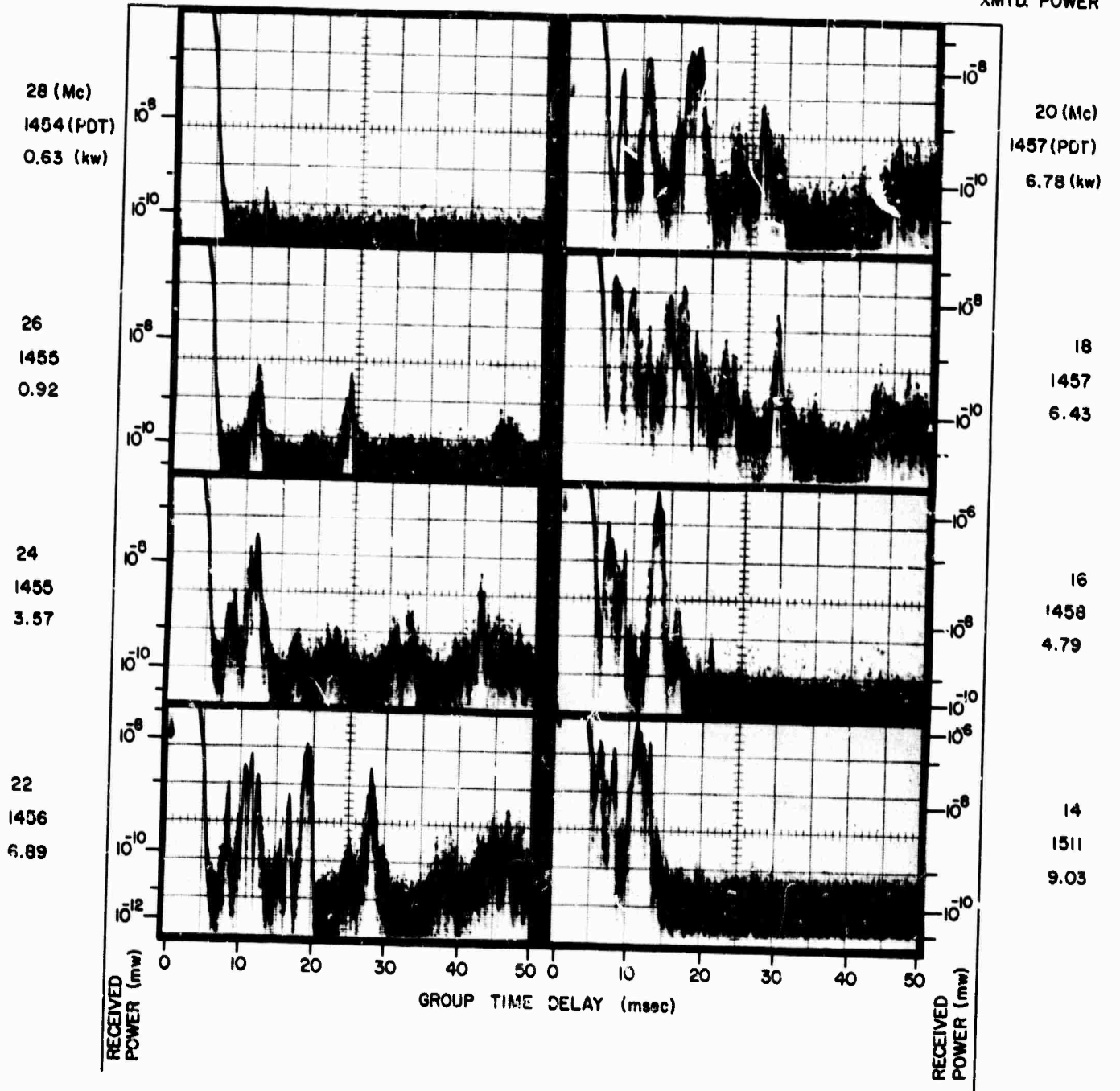

A RECORDS, 28 APR 1965, 122° BEARING

FREQ.  
TIME  
XMTD. POWER

FREQ.  
TIME  
XMTD. POWER

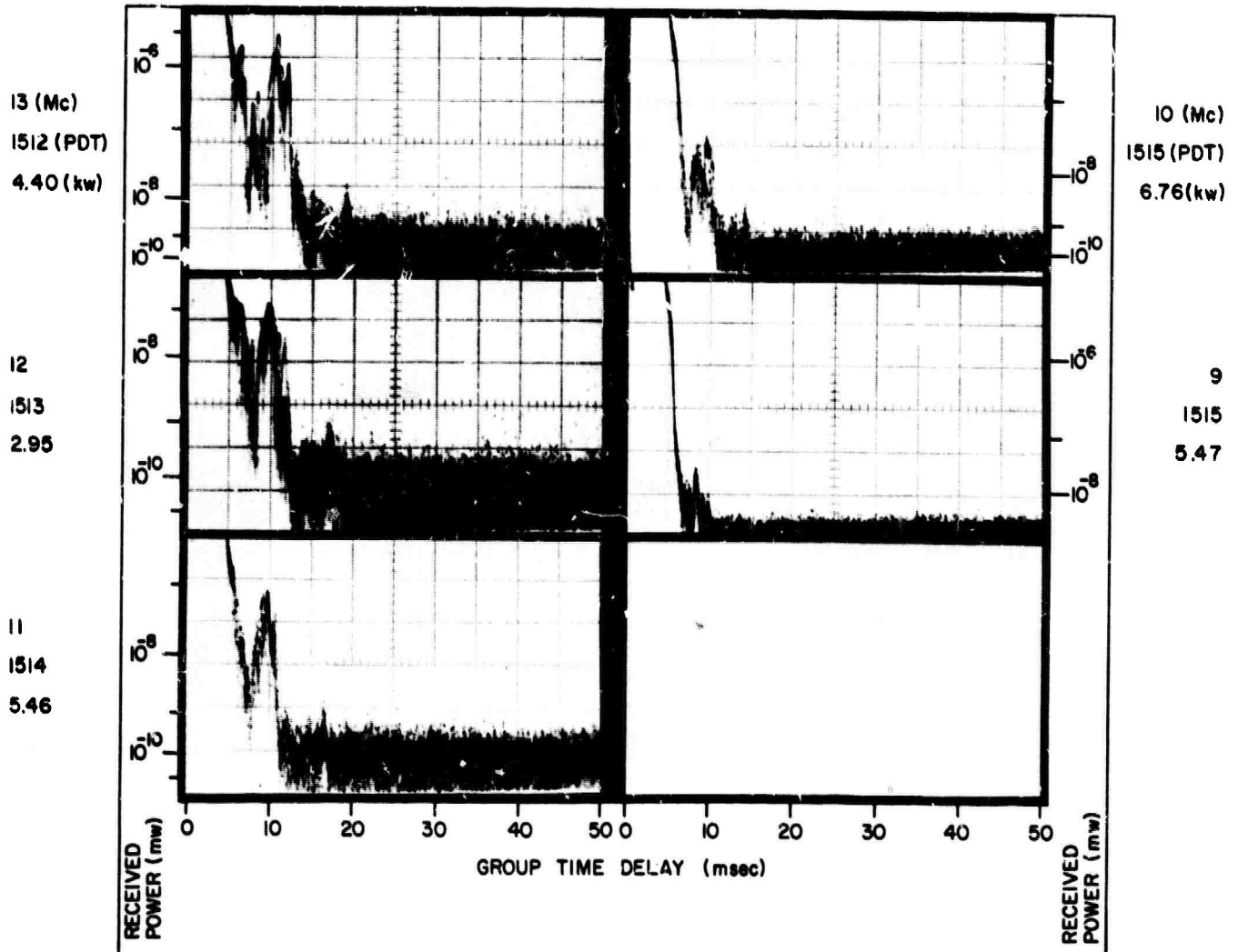

A RECORDS, 28 APR 1965, 122° BEARING

## DOCUMENT CONTROL DATA - R&amp;D

*(Security classification of title, body of abstract and indexing annotation must be entered when the overall report is classified)*

1. ORIGINATING ACTIVITY (Corporate author) Stanford Electronics Labs Stanford University, Stanford, Calif.		2a. REPORT SECURITY CLASSIFICATION UNCLASSIFIED	2b. GROUP
3. REPORT TITLE SWEEP-FREQUENCY BACKSCATTER WITH CALIBRATED AMPLITUDE			
4. DESCRIPTIVE NOTES (Type of report and inclusive dates) Technical Report			
5. AUTHOR(S) (Last name, first name, initial) C. R. Gilliland			
6. REPORT DATE October 1965	7a. TOTAL NO. OF PAGES 128	7b. NO. OF REFS 3	
8a. CONTRACT OR GRANT NO. ONR Nonr--225(64)	9a. ORIGINATOR'S REPORT NUMBER(S) SU-SEL-65-095 Technical Report No. 111		
b. PROJECT NO. ARPA Order 196-65	9b. OTHER REPORT NO(S) (Any other numbers that may be associated with this report)		
c.			
d.			
10. AVAILABILITY/LIMITATION NOTICES Qualified requesters may obtain copies from DDC. Foreign announcement and dissemination by DDC not authorized.			
11. SUPPLEMENTARY NOTES		12. SPONSORING MILITARY ACTIVITY ONR	

## 13. ABSTRACT

The purpose of this work was the compilation of representative sets of experimental records of sweep-frequency ground backscatter--quantitative in amplitude, frequency, and group time delay. These data are intended to serve as a comprehensive source of high quality experimental data for theoretical backscatter studies currently in progress.

The invention of computer techniques for the study of ionospherically propagated ground backscatter has opened new avenues for productive research. However, efforts to exploit the computer synthesis have been hampered by the apparent lack of published, adequately-calibrated backscatter records. To gather these needed data, a special, highly instrumented and calibrated backscatter radar was assembled and operated for many months. The result is a large quantity of experimental information that should be of general use to the scientific community in the study of backscatter.

Security Classification

14. KEY WORDS	LINK A		LINK B		LINK C	
	ROLE	WT	ROLE	WT	ROLE	WT
IONOSPHERIC PROPAGATION GROUND BACKSCATTER, Calibrated GROUND BACKSCATTER, Sweep Frequency GROUND BACKSCATTER, Power versus Time Delay GROUND BACKSCATTER, Power versus Time versus Frequency						

INSTRUCTIONS

1. **ORIGINATING ACTIVITY:** Enter the name and address of the contractor, subcontractor, grantee, Department of Defense activity or other organization (corporate author) issuing the report.

2a. **REPORT SECURITY CLASSIFICATION:** Enter the overall security classification of the report. Indicate whether "Restricted Data" is included. Marking is to be in accordance with appropriate security regulations.

2b. **GROUP:** Automatic downgrading is specified in DoD Directive 5200.10 and Armed Forces Industrial Manual. Enter the group number. Also, when applicable, show that optional markings have been used for Group 3 and Group 4 as authorized.

3. **REPORT TITLE:** Enter the complete report title in all capital letters. Titles in all cases should be unclassified. If a meaningful title cannot be selected without classification, show title classification in all capitals in parenthesis immediately following the title.

4. **DESCRIPTIVE NOTES:** If appropriate, enter the type of report, e.g., interim, progress, summary, annual, or final. Give the inclusive dates when a specific reporting period is covered.

5. **AUTHOR(S):** Enter the name(s) of author(s) as shown on or in the report. Enter last name, first name, middle initial. If military, show rank and branch of service. The name of the principal author is an absolute minimum requirement.

6. **REPORT DATE:** Enter the date of the report as day, month, year, or month, year. If more than one date appears on the report, use date of publication.

7a. **TOTAL NUMBER OF PAGES:** The total page count should follow normal pagination procedures, i.e., enter the number of pages containing information.

7b. **NUMBER OF REFERENCES:** Enter the total number of references cited in the report.

7c. **CONTRACT OR GRANT NUMBER:** If appropriate, enter the applicable number of the contract or grant under which the report was written.

8a, 8c, & 8d. **PROJECT NUMBER:** Enter the appropriate military department identification, such as project number, subproject number, system numbers, task number, etc.

9a. **ORIGINATOR'S REPORT NUMBER(S):** Enter the official report number by which the document will be identified and controlled by the originating activity. This number must be unique to this report.

9b. **OTHER REPORT NUMBER(S):** If the report has been assigned any other report numbers (either by the originator or by the sponsor), also enter this number(s).

10. **AVAILABILITY/LIMITATION NOTICES:** Enter any limitations on further dissemination of the report, other than those

imposed by security classification, using standard statements such as:

- (1) "Qualified requesters may obtain copies of this report from DDC."
- (2) "Foreign announcement and dissemination of this report by DDC is not authorized."
- (3) "U. S. Government agencies may obtain copies of this report directly from DDC. Other qualified DDC users shall request through \_\_\_\_\_."
- (4) "U. S. military agencies may obtain copies of this report directly from DDC. Other qualified users shall request through \_\_\_\_\_."
- (5) "All distribution of this report is controlled. Qualified DDC users shall request through \_\_\_\_\_."

If the report has been furnished to the Office of Technical Services, Department of Commerce, for sale to the public, indicate this fact and enter the price, if known.

11. **SUPPLEMENTARY NOTES:** Use for additional explanatory notes.

12. **SPONSORING MILITARY ACTIVITY:** Enter the name of the departmental project office or laboratory sponsoring (paying for) the research and development. Include address.

13. **ABSTRACT:** Enter an abstract giving a brief and factual summary of the document indicative of the report, even though it may also appear elsewhere in the body of the technical report. If additional space is required, a continuation sheet shall be attached.

It is highly desirable that the abstract of classified reports be unclassified. Each paragraph of the abstract shall end with an indication of the military security classification of the information in the paragraph, represented as (TS), (S), (C), or (U).

There is no limitation on the length of the abstract. However, the suggested length is from 150 to 225 words.

14. **KEY WORDS:** Key words are technically meaningful terms or short phrases that characterize a report and may be used as index entries for cataloging the report. Key words must be selected so that no security classification is required. Identifiers, such as equipment model designation, trade name, military project code name, geographic location, may be used as key words but will be followed by an indication of technical context. The assignment of links, roles, and weights is optional.