

UNCLASSIFIED

| |
|---|
| |
| |
| |
| AD NUMBER |
| AD475394 |
| NEW LIMITATION CHANGE |
| TO Approved for public release, distribution unlimited |
| FROM Distribution: Further dissemination only as directed by Naval Postgraduate School, Monterey, CA, 1965, or higher DoD authority. |
| AUTHORITY |
| USNPS ltr, 23 Sep 1971 |

THIS PAGE IS UNCLASSIFIED

1965

Dist.

475394

UNITED STATES NAVAL POSTGRADUATE SCHOOL



THESIS

STEADY STATE STEAM TO AIR TESTING
FACILITY FOR COMPACT HEAT EXCHANGERS

John P. Ward

This document may be further distributed by any holder only with specific prior approval of the U. S. Naval Postgraduate School (Code 035).

STEADY STATE STEAM TO AIR TESTING
FACILITY FOR COMPACT HEAT EXCHANGERS

* * * * *

John P. Ward

STEADY STATE STEAM TO AIR TESTING
FACILITY FOR COMPACT HEAT EXCHANGERS

by

John P. Ward

Lieutenant, United States Navy

Submitted in partial fulfillment of
the requirements for the degree of

MASTER OF SCIENCE
IN
MECHANICAL ENGINEERING

United States Naval Postgraduate School
Monterey, California

1 9 6 5

STEADY STATE STEAM TO AIR TESTING
FACILITY FOR COMPACT HEAT EXCHANGERS

by

John P. Ward

This work is accepted as fulfilling
the thesis requirements for the degree of

MASTER OF SCIENCE

IN

MECHANICAL ENGINEERING

from the

United States Naval Postgraduate School



Faculty Advisor

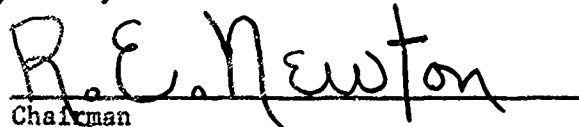

Chairman

Department of Mechanical Engineering

Approved:



Academic Dean

ABSTRACT

A compact heat exchanger testing facility was constructed at the United States Naval Postgraduate School. The testing facility is used to collect heat transfer and friction factor data by the steady state steam to air technique. Heat exchangers with frontal dimensions of up to 12 inches by 12 inches can be tested. The maximum pressure drop which can be produced across the air side of a heat exchanger is 2.5 psi. The testing facility was designed to obtain data for exchanger air side Reynolds numbers from 500 to 10,000. A description of the apparatus, the experimental method and equations and an evaluation are given.

ACKNOWLEDGMENTS

The writer expresses his thanks to the United States Naval Bureau of Ships for making this project possible through funding. He also expresses his sincere appreciation for the assistance and encouragement from his advisor, Professor Paul F. Pucci, for the technical assistance given by Joe Beck and the unfailing patience of Betty Allen while procuring the material.

TABLE OF CONTENTS

| Section | Title | Page |
|--------------|---|------|
| 1. | Introduction | 1 |
| 2. | Theory | 3 |
| | Heat Transfer characteristics | 3 |
| | Friction Factor | 5 |
| | Reynolds Number | 9 |
| 3. | Description of the Test Apparatus | 9 |
| | Air System | 10 |
| | Steam System | 12 |
| | Pressure Instrumentation | 20 |
| | Temperature Instrumentation | 21 |
| 4. | Experimental Method and Equations | 23 |
| | Mass Rate of Air Flow | 23 |
| | Heat Transfer Calculations | 26 |
| | Friction Factor Calculations | 30 |
| | Heat Balance Calculations | 33 |
| 5. | Evaluation | 36 |
| Appendix I | Operating procedure | 40 |
| Appendix II | Digital computer program for data reduction | 45 |
| Appendix III | Graphs for approximate equations | 60 |

LIST OF ILLUSTRATIONS

| Figure | Page |
|--|------|
| 1. Picture of test apparatus, downstream section | 15 |
| 2. Picture of test apparatus, test core section | 16 |
| 3. Picture of instrumentation panel | 17 |
| 4. Air system | 18 |
| 5. Steam system | 19 |
| 6. Colburn-j and friction factor vs. test core Reynolds number | 38 |
| 7. Mass rate of air flow vs. orifice pressure differential | 44 |
| 8. Thermal expansion factor vs. temperature | 61 |
| 9. Contraction coefficient vs. σ | 62 |
| 10. Saturated steam pressure vs. temperature | 63 |
| 11. Saturated steam dynamic viscosity vs. temperature | 64 |
| 12. Saturated steam specific volume vs. temperature | 65 |
| 13. Saturated steam enthalpy vs. pressure | 66 |
| 14. Superheated steam enthalpy vs. temperature | 67 |
| 15. Saturated liquid enthalpy vs. pressure | 68 |

NOMENCLATURE

English Letter Symbols

- A_a - Air side total heat transfer area, ft^2
- A_c - Air side free flow area, ft^2
- A_{fa} - Air side fin area, ft^2
- A_{fr} - Air side frontal area, ft^2
- A_{fs} - Steam side fin area, ft^2
- A_s - Steam side total heat transfer area, ft^2
- A_{wa} - Air side wall area, ft^2
- A_{ws} - Steam side wall area, ft^2
- C - Coefficient of discharge for a metering orifice
- C_c - Jet contraction ratio
- C_d - Coefficient of discharge of a fluid orifice for a given value of β
- c_p - Specific heat of air at constant pressure, $\text{BTU}/(\text{lb}_m \text{ } ^\circ\text{F})$
- d - Diameter of fluid metering orifice, in.
- D - Air orifice duct diameter, in.
- D_d - Hydraulic diameter of duct immediately downstream of test core, in.
- ERROR - Error in heat balance between steam side and air side, percent
- f - Fanning friction factor in test core
- f_d - Friction factor in duct immediately downstream of test core
- f_m - Friction factor of a passage in test core
- F - Velocity of approach factor for the fluid metering orifice
- F_A - Thermal expansion factor for the fluid metering orifice
- g_c - Proportionality factor in Newton's Second Law, $g_c = 32.174 \text{ lb}_m \text{ ft}/(\text{lb}_f \text{ sec}^2)$
- G - Test core air mass velocity, $\text{lbs}_m/(\text{hr ft}^2)$

- h - Unit conductance for thermal convection heat transfer (film coefficient), $\text{BTU}/(\text{hr ft}^2 \text{ } ^\circ\text{F})$
- h_c - Enthalpy of the condensate leaving the test core, BTU/lb_m
- h_s - Enthalpy of steam, BTU/lb_m
- H - Humidity ratio for air, $\text{lb}_m \text{ water}/\text{lb}_m \text{ dry air}$
- k - Unit thermal conductivity, $\text{BTU}/(\text{hr ft}^2 \text{ } ^\circ\text{F}/\text{ft})$
- K_c - Contraction coefficient
- K_d - Velocity distribution coefficient
- K_e - Expansion coefficient
- l - Fin length equal to one half of total fin height
- l_d - Length of duct from downstream face of test core to downstream pressure tap, in.
- l_w - Wall thickness between steam and air side of test core, in.
- L - Test core flow length, ft.
- n - $\sqrt{2 h/k\delta}$
- \dot{m} - Mass rate of air flow, lb_m/hr .
- P - Pressure, in. H_2O , in. Hg, lb_f/in^2 , lb_f/ft^2
- P_b - Barometric pressure, in. Hg
- Q - Heat transfer rate, BTU/hr
- R - Gas constant for air, $53.3 \text{ ft lb}_f/(\text{lb}_m \text{ } ^\circ\text{R})$
- r_h - Hydraulic radius, $(A_c \bar{l}/A_s)$, ft, ($4 r_h$ -hydraulic diameter)
- \dot{s} - Mass rate of steam flow, lb_m/hr
- t - Temperature, $^\circ\text{F}$
- T - Absolute temperature, $^\circ\text{R}$, $^\circ\text{K}$
- U - Unit overall thermal conductance, $\text{BTU}/(\text{hr } ^\circ\text{F ft}^2)$
- V - Velocity, ft/sec
- v - Specific volume, ft^3/lb_m
- \dot{w}_c - Mass rate of condensate from test core, lb_m/hr

- x - Ratio of pressure upstream of the fluid metering orifice to pressure differential across the orifice
- X_c - Humidity correction to the specific heat of air
- X_m - Humidity correction to the density of air
- Y - Net expansion factor for a square-edged metering orifice

Greek Letter Symbols

- β - Ratio of fluid metering orifice diameter to duct diameter
- Δ - Denotes difference
- δ - Fin thickness, in.
- η - Fin temperature effectiveness
- η_0 - Total surface temperature effectiveness for air side
- η_s - Total surface temperature effectiveness for steam side
- σ - Ratio of free-flow to frontal area, A_c/A_{FR}
- μ - Dynamic viscosity, $\text{lb}_m/(\text{hr ft})$
- ρ - Density, lb_m/ft^3
- ρ_{ave} - Average density of air in test core for isothermal test, lb_m/ft^3
- ρ_m - Mean density of air in test core for hot core test, lb_m/ft^3

Dimensionless Groupings

- N_{Re} - Reynolds number, $(4r_h G/\mu)$
- N_{St} - Stanton number, (h/Gc_p)
- N_{Pr} - Prandtl number, $(\mu c_p/k)$
- j - Colburn-j $(N_{St} N_{Pr}^{2/3})$
- NTU - Number of heat transfer units for an exchanger $(A_s U/m c_f)$

Subscripts

- 1 - Air upstream of core
- 2 - Air downstream of core
- o - Air metering orifice
- a - Air side of test core
- c - Core
- f - Fin
- f - Air film in test core
- s - Steam side of test core
- so - Steam metering orifice
- s1 - Steam in top header
- s2 - Steam in bottom header
- w - Wall between air and steam sides of test core
- s - Square fin
- t - Triangular fin
- c - Circular tube

Force and Mass Units

- lb_m - Denotes pounds mass in distinction to
- lbf - Denoting pounds force

1. Introduction

Steady state tests transferring heat from condensing steam to flowing air are used to determine experimentally the heat transfer characteristics for compact heat exchangers. The friction factor is determined from the air pressure drop across the heat exchanger. Steam and air are used as the working fluids in the tests because they are readily available and produce effects which are easily analyzed. The heat transfer characteristics are given by Colburn-j heat transfer modulus evaluated from the steady state steam to air test (referred to here-in as hot core test). The friction factor is evaluated from both the hot core test and the isothermal test (referred to as cold core test). The Colburn-j heat transfer modulus and friction factor are normally presented graphically as functions of the heat exchanger Reynolds number. Development of these three parameters is given in the theory section.

In addition to determining the Colburn-j and friction factor, a heat balance is performed on the exchanger to check the consistency of the experimental data.

The testing facility is similar in design to one built at Stanford University in 1947. The Stanford facility was built under a United States Navy contract to evaluate finned surfaces for use in compact heat exchangers and is described by Kays in reference [3].

Compact heat exchangers which are suitable for steady state steam to air testing have plate-fin geometry as shown below.

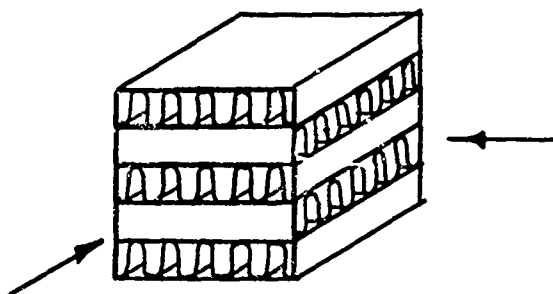

The steady state steam to air testing facility was designed and built to accommodate a heat exchanger with frontal dimensions of up to 12 inches by 12 inches. The facility is capable of producing air side Reynolds numbers from 500 to 10,000. An air side pressure drop of 2.5 psi can be obtained.

The testing facility is described and the experimental method and equations for data reduction are presented. The data reduction equations are conveniently arranged for programing on a digital computer. A test of a heat exchanger of known characteristics is presented as an evaluation of the testing facility. The operating procedures and the computer program for data reduction with accompanying instructions are given in the appendix.

2. Theory

Heat Transfer Characteristics. The heat transfer characteristics of a compact heat exchanger are best represented by dimensionless groupings. This generalizes the results so that they may be used for working fluids other than steam and air. The succeeding development is that commonly used in the field; see Kays and London [4]. The Colburn-j heat transfer modulus is selected for this purpose as it combines heat transfer characteristics and fluid properties. The Colburn-j modulus is defined as:

$$j \equiv N_{St} N_{Pr}^{2/3} = \left(\frac{h}{G C_p} \right) \left(\frac{\mu C_p}{k} \right)^{2/3}$$

where the unit conductance for convective heat transfer, h , must be determined experimentally. The use of a steam to air system is one of the most direct methods of experimentally determining h .

The unit conductance for convective heat transfer, h , for the air side, air being the fluid of interest, is determined from energy balance considerations within the exchanger. Low pressure slightly superheated steam, about 6 psig with 5 degrees superheat, enters the top of the heat exchanger steam side. The steam reaches its saturation temperature in a very short distance after entering the exchanger. Constant temperature is maintained as the steam condenses for the remainder of travel. The air is heated continuously as it passes through the exchanger. The sketch below illustrates the temperature variations in the working fluids as a function of the heat transfer area.

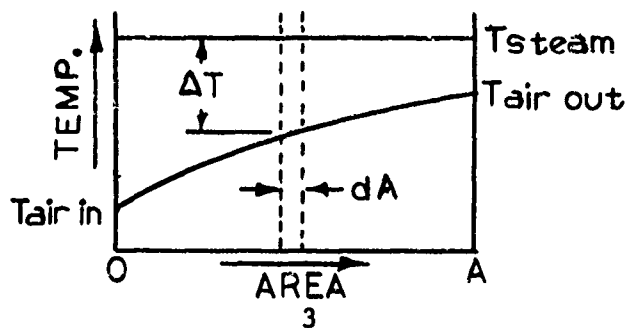

An energy balance for the differential area dA yields the equation for the heat transfer rate as:

$$\begin{array}{ccccc} \dot{q} & = & \dot{m} c_p dT_{air} & = & U dA \Delta T \\ \text{(heat transfer rate)} & & \text{(heat transfer rate to the air)} & & \text{(heat transfer rate from steam to air)} \end{array}$$

Rearrangement gives:

$$- \frac{dT_{air}}{(T_{steam} - T_{air})} = - \frac{U dA}{\dot{m} c_p}$$

For small over-all changes in fluid properties and a relatively uniform flow distribution in the heat exchanger, the over-all unit conductance, U , may be assumed to be constant. Integration over the total area then yields:

$$\ln \left(\frac{T_{steam} - T_{air out}}{T_{steam} - T_{air in}} \right) = - \frac{U A_a}{\dot{m} c_p}$$

The dimensionless grouping on the right side of the equation is defined as the Number of heat Transfer Units, NTU. Thus the equation may be written as:

$$\ln \left(\frac{T_{steam} - T_{air out}}{T_{steam} - T_{air in}} \right) = - NTU$$

or

$$\left(\frac{T_{steam} - T_{air out}}{T_{steam} - T_{air in}} \right) = e^{-NTU}$$

The over-all unit conductance based upon the total air side heat transfer area must include a factor to account for the temperature variation in the fin areas. The over-all temperature effectiveness, η , may be written as:

$$\eta = 1 - \frac{A_f}{A} (1 - \eta_f)$$

where A_f is the fin area and η_f is the fin temperature effectiveness. The effectiveness for a fin of constant conduction cross section as given by Kays and London [4] is:

$$\eta_f = \frac{\tanh m\ell}{m\ell}$$

where $m = \sqrt{\frac{2h}{k\delta}}$ for thin sheet fins

ℓ = one half fin height for wall to wall fins

Summing the resistances to heat flow then yields:

$$\frac{1}{U} = \frac{A_s}{\eta_s A_s h_s} + \frac{A_s \ell_w}{A_w k_w} + \frac{1}{\eta_o h}$$

(over-all resistance) (steam side resistance) (wall resistance) (air side resistance)

The convective coefficient for the air side, h, may be solved for giving:

$$h = \frac{1}{\eta_o \left[\frac{1}{U} - A_s \left(\frac{1}{\eta_s A_s h_s} + \frac{\ell_w}{A_w k_w} \right) \right]} \dots \dots \dots (1)$$

A value of h_s equal to 2000 BTU/(hr ft² °F) is assumed. A fifty percent error in this assumption results in approximately two percent error in the value of h. Accordingly the heat transfer coefficient for the air side, h, may be evaluated by experimentally measuring the fluid temperatures and the air mass rate of flow.

Friction Factor. The flow of a fluid through an exchanger results in a pressure differential caused by the flow contraction as the entrance, the fluid friction in the exchanger and the flow expansion at the exchanger

exit. These pressure effects are graphically represented below.

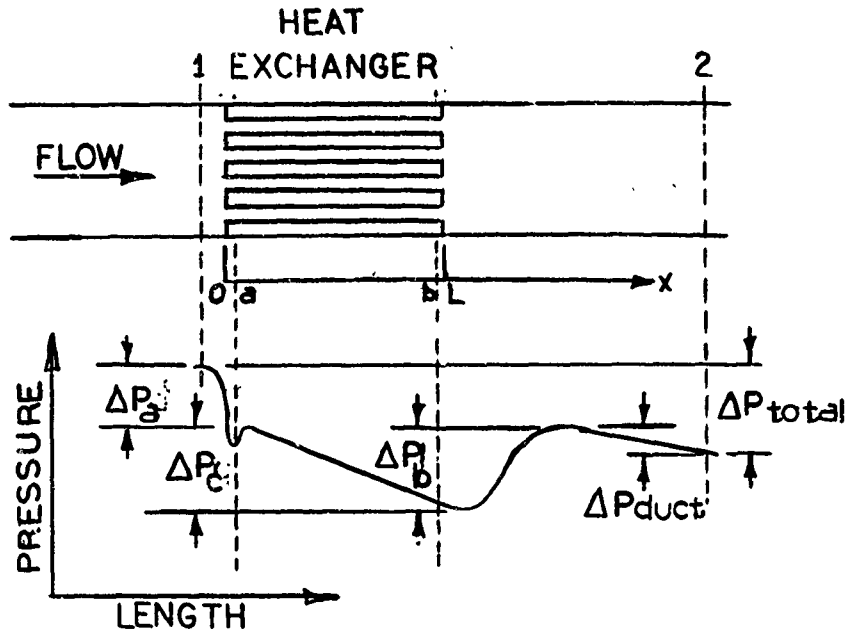

To define a meaningful heat exchanger friction factor, the entrance and exit pressure effects must be eliminated from the total pressure differential. The friction factor will then be based solely upon the mean wall shear. The problem of entrance and exit pressure effects has been investigated both analytically and experimentally by Kays.[2].

The effect of pressure loss in the downstream duct is included in the total pressure drop in order that point 2 may be located downstream sufficiently to assure complete pressure recovery. The total pressure differential from point 1 to point 2 is then:

$$P_{\text{total}} = \Delta P_a + \Delta P_c - \Delta P_b + \Delta P_{\text{duct}}$$

The expression for the pressure effect due to flow contraction at the entrance is given by Kays [2] is:

$$\frac{\Delta P_a}{\rho a} = \frac{V_a^2}{2g_c} (1 - \sigma^2) + \frac{K_c V_a^2}{2g_c}$$

and for the flow expansion at the exit is:

$$\frac{\Delta P_b}{\rho_b} = \frac{v_b^2}{2g_c} (1 - \sigma^2) - \frac{K_e v_b^2}{2g_c}$$

with σ denoting the exchanger free flow to frontal area ratio. K_c and K_e are contraction and expansion coefficients which are functions of exchanger geometry and Reynolds number. Noting that the velocity may be related to the mass velocity and that the density change from section one to a and b to two will be very small compared to the total density change, the above equations yield:

$$\Delta P_a = \frac{G^2}{2g_c \rho_1} (1 - \sigma^2 + K_c)$$

and

$$\Delta P_b = \frac{G^2}{2g_c \rho_2} (1 - \sigma^2 - K_e)$$

The pressure drop in the exchanger may be found by writing Bernoulli's equation in the differential form to include the Fanning friction term.

Using the mass velocity, G , the equation as given by Kays [3] is:

$$-\frac{dP_c}{\rho} = \frac{G^2}{2g_c} d\left(\frac{1}{\rho^2}\right) + f \frac{G^2}{2g_c \rho^2} \left(\frac{dx}{r_h}\right)$$

or

$$-dP_c = \frac{G^2}{2g_c} \left[f \left(\frac{1}{\rho}\right) \frac{dx}{r_h} - \frac{2d\rho}{\rho^2} \right]$$

By defining the mean specific volume in the exchanger as:

$$v_m = \left(\frac{1}{\rho_m}\right) = \frac{1}{L} \int_0^L \frac{dx}{\rho}$$

and integrating from ρ_a , 0 to ρ_b , L , the exchanger pressure differential is given by:

$$\Delta P_c = \frac{G^2}{2g_c \rho_a} \left[2 \left(\frac{\rho_a}{\rho_b} - 1\right) + \frac{rL}{r_h} \left(\frac{\rho_a}{\rho_m}\right) \right]$$

The mean specific volume is found from its definition by replacing it with its value as given in the equation of state for a perfect gas:

$$\frac{1}{v} = \rho = \frac{P}{RT}$$

and expressing temperature and pressure as functions of x . As the pressure variation is small compared to the temperature variation, an arithmetic average value of P may be used:

$$P = \frac{P_a + P_b}{2}$$

The expression for temperature as a function of x may be written from the temperature-NTU relation as:

$$T = T_s - (T_s - T_a) e^{-\frac{NTU}{L} x}$$

where T_s is the steam temperature. Substitution of the expressions for temperature and pressure into the equation for the mean specific volume yields:

$$v_m = \frac{1}{\rho_m} = \frac{2R}{L(P_a + P_b)} \int_0^L \left[T_s - (T_s - T_a) e^{-\frac{NTU}{L} x} \right] dx$$

Integration and using the equation of state for a perfect gas to simplify, and assuming no temperature change from one to a and b to two the following equation obtains:

$$\frac{1}{\rho_m} = \frac{2}{T_s \rho_a + T_b \rho_b} \left[T_s - \frac{(T_2 - T_1)}{NTU} \right]$$

An alternate expression may be written by substituting the NTU-temperature relation into the above equation. This expression is:

$$\frac{1}{\rho_m} = \frac{2R}{P_a + P_b} (T_s - LMTD)$$

with LMTD being the Log Mean Temperature Difference.

The pressure loss in the downstream duct may be evaluated as:

$$\frac{\Delta P_{\text{duct}}}{\rho_d} = 4 \left(\frac{f_d l_d}{D_d} \right) \frac{V_d^2}{2g_c}$$

where the density, ρ_d , the friction factor, f_d , the length of duct from section b to 2, l_d , the hydraulic diameter, D_d , and the velocity, V_d , are all quantities associated with the downstream duct. The velocity in the downstream duct may be related to quantities appearing in the previous pressure loss equations. If the downstream duct has the same dimensions as the exchanger and small density variations are neglected, the continuity equation gives

$$V_d = \left(\frac{\dot{m}}{A_c} \right) \left(\frac{1}{\rho_b} \right) \left(\frac{A_c}{A_{fr}} \right)$$

or

$$V_d = \frac{G \sigma}{\rho_b}$$

Thence

$$\Delta P_{\text{duct}} = 4 \left(\frac{f_d l_d}{D_d} \right) \frac{G^2 \sigma^2}{2g_c \rho_b}$$

Again assuming that the density changes between section 1 to a and b to 2 are negligible, the various pressure drops are summed yielding:

$$\Delta P_{\text{total}} = \frac{G^2}{2g_c} \left[\frac{(1 - \sigma^2 + K_c)}{\rho_1} + \frac{2(\rho_1 - \rho_2)}{\rho_1 \rho_2} + \frac{fL}{r_h \rho_m} - \frac{(1 - \sigma^2 - K_e)}{\rho_2} + \frac{4 \left(\frac{f_d l_d}{D_d} \right) \sigma^2}{\rho_2} \right]$$

Manipulation of the equation gives:

$$\Delta P_{\text{total}} = \frac{G^2}{2g_c} \left[\frac{fL}{r_h \rho_m} + \frac{K_c - (\sigma^2 + 1)}{\rho_1} + \frac{(1 + K_e + \sigma^2 (1 + 4 \frac{f_d l_d}{D_d}))}{\rho_2} \right]$$

and solving the equation for the friction factor we obtain:

$$f = \frac{\eta \rho_m}{L} \left[\frac{P_{total}}{G^2/2g_c} - \frac{(K_c - \sigma^2 - 1)}{\rho_1} - \frac{\left\{ 1 + K_e + \sigma^2 \left(1 + 4 \frac{f_d d}{D_d} \right) \right\}}{\rho_2} \right] \dots \dots \dots (2)$$

Therefore the friction factor, f, for a heat exchanger of given geometry may be found by experimentally determining the mass rate of air flow, the entrance and exit air pressures and temperatures and the steam temperature.

Reynolds Number. For uniformity of reporting test results, the Reynolds number is defined in the same manner as given by Kays and London.[4]. This definition embodies the hydraulic diameter as the characteristic length and the velocity based on the minimum free flow area. Thus:

$$N_{Re} = \frac{D_h V \rho}{\mu} = \frac{4 r_h \dot{m}}{\mu A_c} = \frac{4 r_h G}{\mu}$$

To evaluate the foregoing characteristics, the test apparatus must be capable of accurately measuring the air state upstream and downstream of the exchanger, the steam state within the exchanger and the mass rate of air flow.

3. Description of the Test Apparatus

General. Air is induced through one side of the compact heat exchanger by a centrifugal compressor and associated ducting. Steam is passed through the other side of the exchanger by the steam system. The air and steam systems are shown diagrammatically in Fig. 4 and Fig. 5. The steam system is designed to give close control of the steam state

within the core. Pressure and temperature instrumentation are provided for measuring the air properties upstream and downstream of the core, the mass rate of air flow, the condition of the steam entering and leaving the core and the mass rate of excess steam and condensate leaving the core.

The test apparatus is shown pictorially in Figs. 1, 2, and 3.

Air System. The air system is made up of 16 gage galvanized steel ducts joined with 1/4 inch steel flanges. The ducting prior to the test section has a maximum dimension of 12 inches square and the ducting after the test section is 14 inches in diameter. The lengths of ducting were designed in accordance with the ASME Power Test Code [7] for establishment of uniform flow and are shown in Fig. 4.

The entrance to the test duct is on the exterior of the building to minimize thermal gradients in the air stream. The entrance is three feet square and is covered by a fine mesh screen to eliminate foreign matter from the air stream. The transition from three feet square to 12 inches square is made in the entrance section, each side of which has the curvature of a quarter ellipse. After a five foot length of duct, a second transition is made from 12 inches square to the test core dimensions. This is followed by the forward instrument section which contains four thermocouple taps, a piezometer ring and two pitot tube taps for conducting vertical and horizontal velocity surveys. Following the test core is the after instrument section which contains nine thermocouple taps and a piezometer ring. A transition is then made to a 14 inch outside diameter duct at the end of which is a standard ASME square edged orifice. Piezometer rings are located one diameter

upstream of the orifice and one-half diameter downstream of the orifice. The duct section downstream of the orifice also contains a thermocouple tap.

Air flow is regulated by a manually operated double sliding plate valve located at the turbo-compressor inlet. The valve plates slide on Teflon runners and the drive screw is ball bearing mounted to eliminate maintenance problems. The double plates constrict the flow symmetrically and facilitate fine control of the air flow. Coarse control of the air flow is accomplished with the blast gate (discharge valve) of the centrifugal compressor.

Air is induced through the test section ducting by a centrifugal compressor rated 6000 cfm at 2.5 psi back pressure. The compressor is driven by a three phase, 220 volt, 100 hp motor. The compressor discharges air through a 20 inch square duct to the exterior of the building.

The air flow is metered by means of a standard ASME square edged orifice designed to the specifications given in the ASME Power Test Code [7]. Four orifice plates made of 1/4 inch type 304 stainless steel were designed with the following orifice diameters. The preceding duct has an inside diameter, D, of 13.875 inches.

| d (in) | $\beta = \frac{d}{D}$ |
|--------|-----------------------|
| 10.406 | 0.75 |
| 6.244 | 0.45 |
| 3.468 | 0.25 |
| 2.081 | 0.15 |

These diameters were selected so that flow rates of from 250 lbs per hour to 22,000 lbs per hour can be measured with the ranges overlapping. The orifice plates are fitted with a centering groove on the bottom and a

scribe mark on the top so that they may be accurately positioned.

The ducting downstream of the test section is insulated with two inch fiber glass insulation covered by aluminum foil, and the air duct is insulated from the test core by 1/8 inch Teflon gaskets.

Steam System. Heating of the test core is accomplished by passing saturated steam through one side of the core. Before entering the core the steam is reduced to a low pressure, about six psig, and a slightly superheated state, about five degrees superheat. In a superheated condition, the state of the steam can accurately be established by pressure and temperature. The few degrees of superheat are quickly lost in the test core and have negligible effect on the calculations. A considerable excess of steam is passed through the core to prevent a thick film of condensate from building up on the heat transfer surfaces.

Steam is supplied from the central steam heating system at 125 psig in a saturated state. It is strained and then reduced to about 30 psig through a 1 - 1/4 inch air operated, pilot controlled pressure reducer. At this point water is injected, if necessary, to desuperheat the steam and then it flows through a 1 - 1/4 inch centrifugal separator which removes all entrained moisture. The steam then passes through a second 1 - 1/4 inch air operated, pilot controlled pressure reducer which reduces it to about six psig. This second reduction slightly superheats the steam. Just prior to entry into the core the steam passes through a short transition section. To provide uniformity of flow in the test core, the transition section is filled with aluminum shavings held in place by a fine mesh stainless steel screen. Steam and

condensate from the bottom of the test core flow through a second transition section to a 1 - 1/4 inch centrifugal separator where the condensate is removed. A float type trap receives the condensate and discharges it at a relatively constant flow rate. The condensate is then subcooled in a small tap water counter flow heat exchanger and collected in a bucket for weighing. The exhaust steam flows from the separator through a standard ASME square edged orifice with flange pressure taps and is discharged to the atmosphere.

Two orifice plates were selected to measure the steam flow rates and have the following orifice diameters. The inside pipe diameter, D_s , is equal to 1.25 inches.

| d_s (in) | $\beta_s = \frac{d_s}{D_s}$ |
|------------|-----------------------------|
| 0.700 | .560 |
| 0.890 | .712 |

The metering orifice was installed as specified in the ASME Power Test Code [7].

Pressure and thermocouple taps were installed in both the upper and lower transition sections and a thermocouple tap was installed upstream of the steam orifice. The entire steam system is well insulated to minimize heat loss.

Compressed air for actuation of the two steam pressure reducers is supplied by two air pressure regulators located on the instrument panel. This combination is designed to hold the downstream steam pressure to ± 0.2 psig. An air line from the air supply of the first pressure reducer was fitted into the steam strainer clean-out plug so that the entire steam system can be blown dry upon completion of a

series of test runs. This should minimize rusting when the system stands idle for long periods of time.



Figure 1. Test apparatus, downstream section.

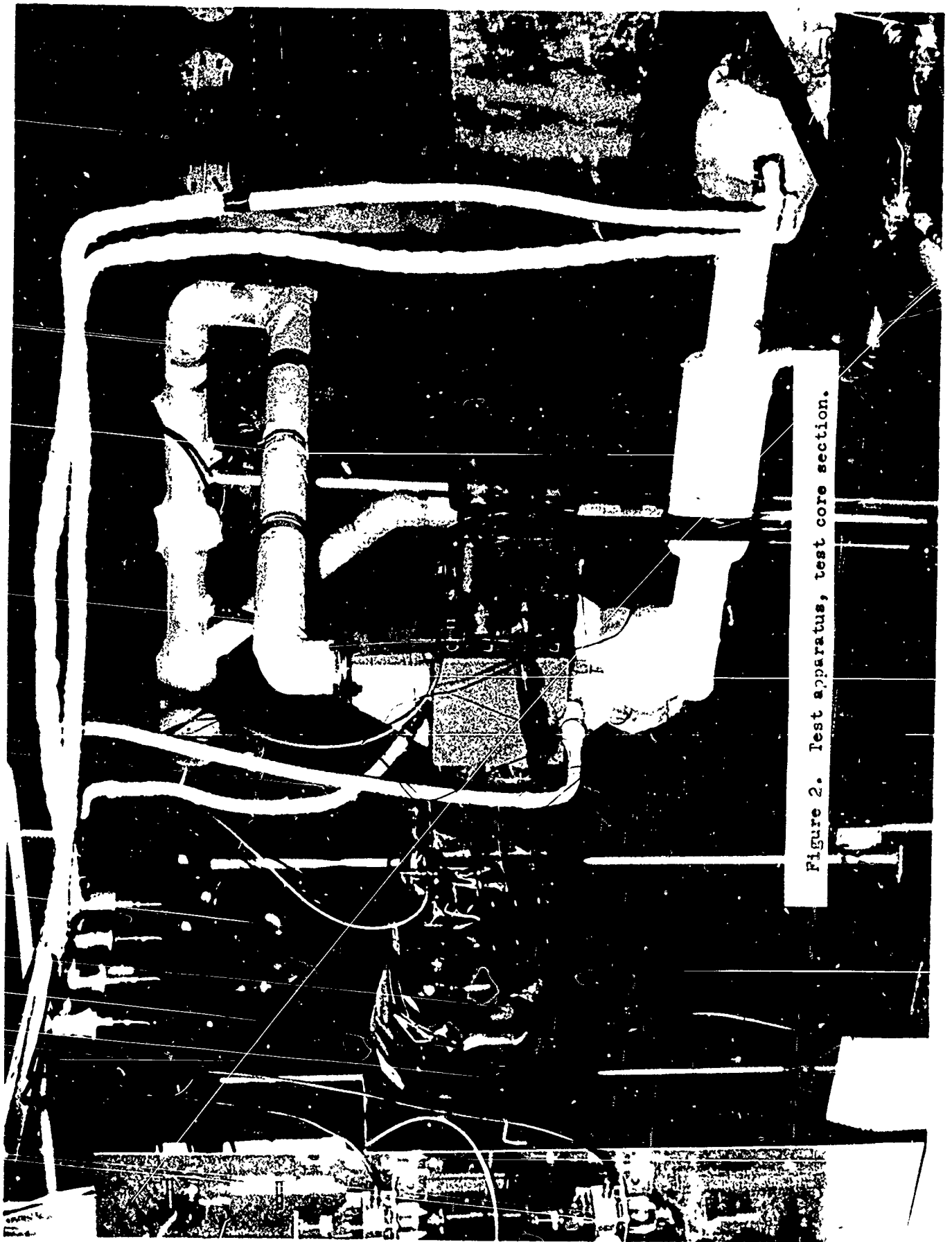

Figure 2. Test apparatus, test core section.

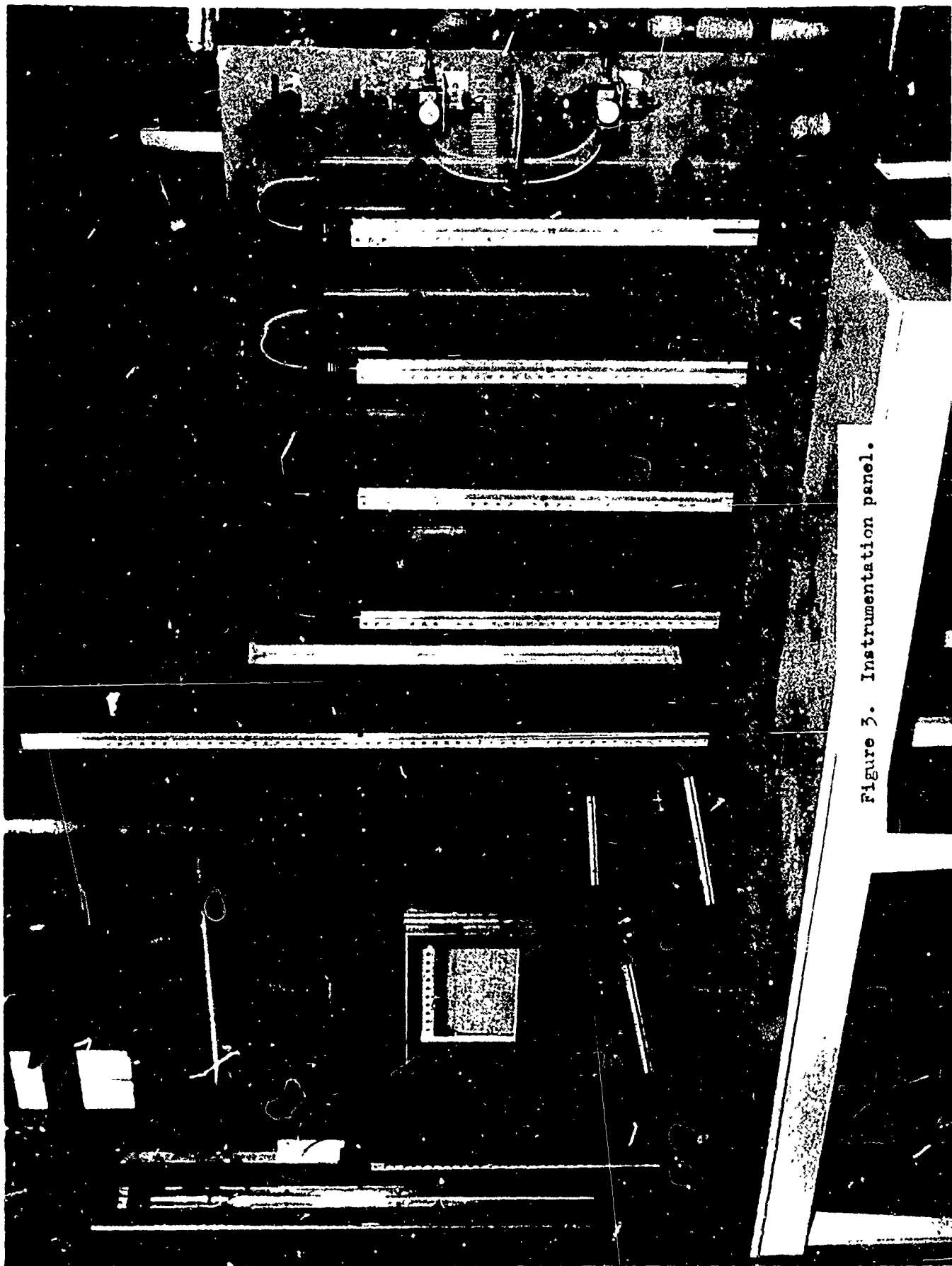
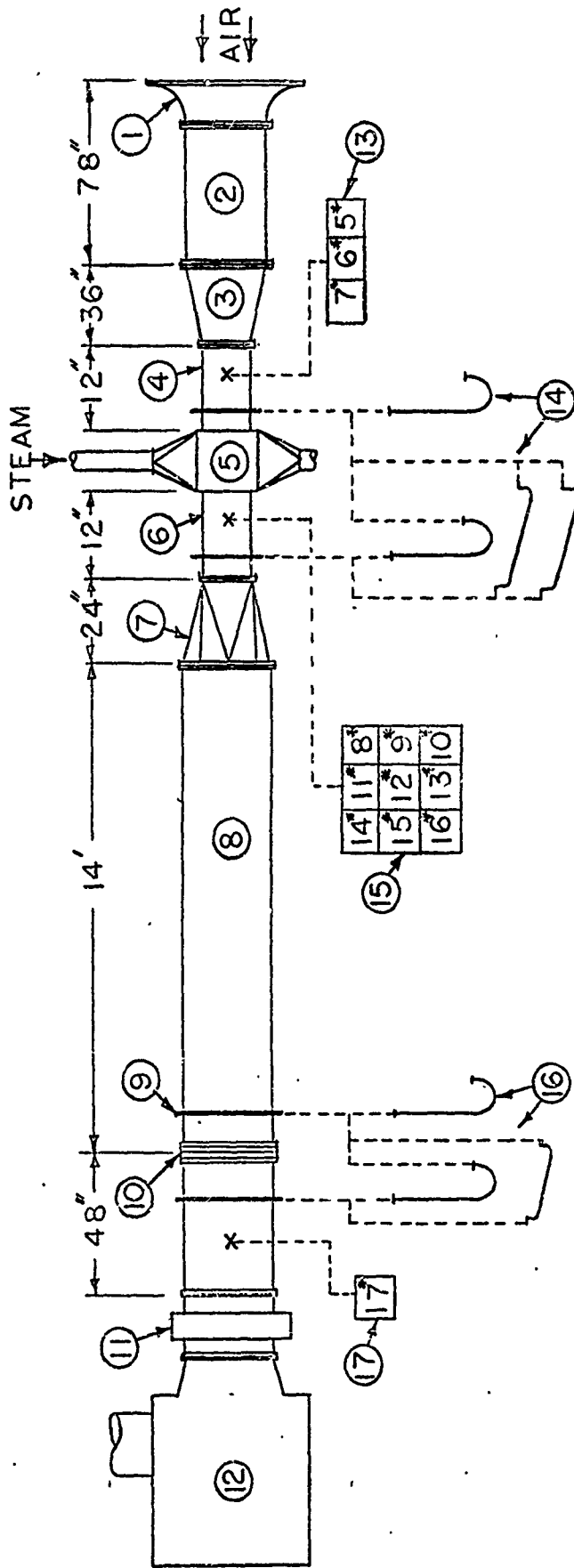

Figure 3. Instrumentation panel.



11. Double sliding plate valve
 12. Turbo compressor
 13. Upstream thermocouples and draft gages
 14. Test core manometers and draft gages
 15. Downstream thermocouples
 16. Air orifice thermocouple
 17. Air orifice thermocouple
- * Denotes thermocouple number designation

1. Entrance section
2. Upstream ducting, 12" X 12"
3. Transition to test core dimensions
4. Upstream instrumentation section
5. Test core
6. Downstream instrumentation section
7. Transition to 14" diameter duct
8. Downstream ducting, 14" diameter
9. Piezometer ring
10. Air metering orifice

FIG. 4 AIR SYSTEM

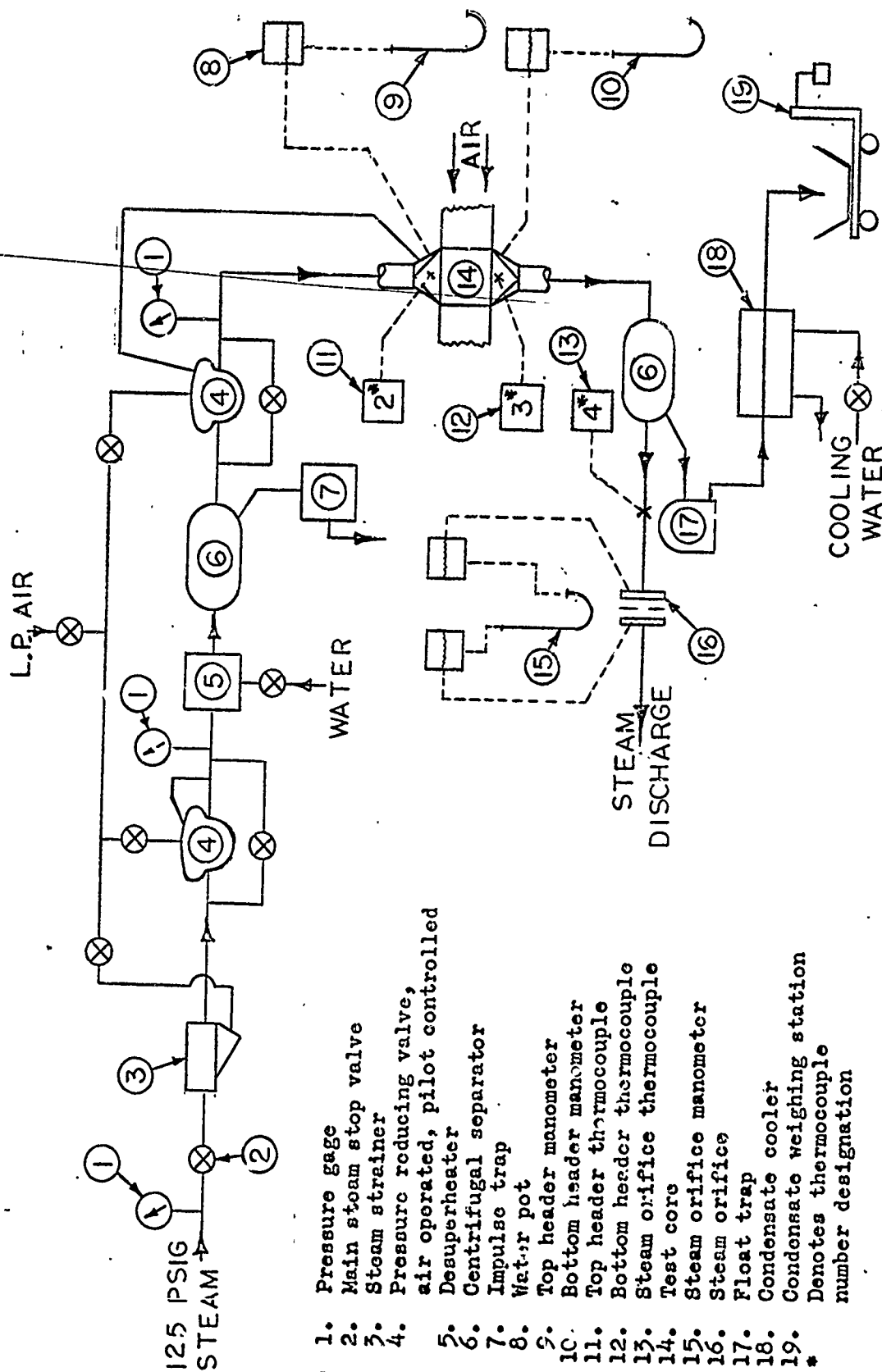

STEAM SYSTEM

FIG. 5

Pressure Instrumentation. Pressure instrumentation is provided for measuring the gage pressure in the air duct upstream of the test core and upstream of the air orifice, the air pressure differential across the test core and air orifice, the steam header pressures and the pressure differential across the steam orifice. Air pressures are measured with well-type single leg water manometers and inclined draft gages. Steam pressures are measured with well type single leg mercury manometers.

A one inch and three inch inclined draft gage and a 60 inch water manometer are used for measuring the air pressure differential across the test core. A 30 inch water manometer is used for measuring gage pressure upstream of the test core. The pressure tap downstream of the test core is located so that full pressure recovery of the air stream is attained. The air orifice pressure differential is measured with a three inch inclined draft gage and a 30 inch water manometer. A 60 inch water manometer is used to measure the gage pressure upstream of the air orifice. Each pressure tap on the air duct consists of four 1/16 inch holes drilled symmetrically around the duct connected together by a piezometer ring of 1/4 inch copper tubing. One quarter inch plastic tubing is used to connect the piezometer rings to the manometers and draft gages and each manometer and draft gage is isolated by a brass toggle valve.

Three 30 inch mercury manometers are used to measure the gage pressure of the top and bottom steam headers and the pressure differential across the steam orifice. Water is used as the intermediate fluid between the steam and mercury and a constant head of water is maintained

by using water pots. The change of level in the water pots is the same order of magnitude as the change in level in the mercury wells and these changes have insignificant effect on the pressure readings. The water pots are stainless steel cylinders three inches in diameter by three inches high and are located above the top of the manometers so that air pockets will not form in the water lines connecting them to the manometers. The connecting water lines are of 1/4 inch stainless steel tubing and each manometer is isolated by a stainless steel toggle valve. The water pots are connected to the steam headers and steam orifice by 5/8 inch copper tubing. The large diameter tubing was selected so that condensate can flow freely back into the steam system and not form pockets which would change the static head on the manometers.

Temperature Instrumentation. All temperatures are measured with copper-constantan thermocouples. The thermocouples are in assemblies manufactured by Honeywell under the trade name MegapaK. The MegapaK consists of a "head" for connecting the extension wires, a "sheath" of 1/8 inch stainless steel tubing with the insulated leads extending down through the center and the measuring junction at the end of the sheath. The thermocouples used for measuring the air stream temperatures are "exposed," meaning that the junction is extended one sheath diameter past the end of the sheath. Those used for measuring the steam temperatures are "remote," meaning that the junction is one sheath diameter from the end of the sheath and the end of the sheath is sealed for pressure tightness. All extension wire is polyvinyl covered 24 gage copper-constantan.

The thermocouple voltages are measured with a Honeywell 24 point

Multipoint recorder. The reference junction is an ice junction and is included in the measuring circuit. The recorder is a D.C. millivolt recorder with a scale of zero to ten millivolts. The smallest division on the chart paper is 1/10 of a millivolt and temperatures may be estimated to 1/100 of a millivolt. The recorder has several modes of operation. On the Multipoint setting it will balance and print each of the 24 points consecutively at a rate of about two seconds per point. On the Selecto-Print setting the recorder will balance and print at about two second intervals any number of the 24 points. On the Hold-on setting it continuously balances on any one of the 24 points but will not print. This setting may be used for obtaining a pen trace by attaching a clip-on pen to the print mechanism. The recorder should be adjusted for zero and span before use and the adjustment procedure is given in the operating procedures.

The temperatures of the air upstream and downstream of the core, and the downstream of the orifice are recorded. Steam temperature in the top and bottom headers and upstream of the steam orifice are also recorded. To obtain an average temperature of air upstream and downstream of the core a system of thermocouples is used. Upstream of the core this consists of three thermocouples placed on the horizontal center line. Downstream of the core nine thermocouples are arranged in a three by three grid with equal spacing between each of the thermocouples and the thermocouples and the wall. In this manner small variations in temperature across the stream can be averaged out. All other temperatures are measured by a single thermocouple. Each penetration through the duct for a thermocouple is fitted with a Swagelok compression fitting

so that the penetration length can be adjusted.

The thermocouples are numbered as shown in Figs. 4 and 5 and the same number is printed beside the temperature reading on the multipoint recorder chart.

4. Experimental Method and Equations

General. The experimental method and equations used are essentially those outlined by Kays [3] for a similar facility. These equations are ~~suited~~ for use with tables and graphs. The equations outlined herein are suited for use in a digital computer program which will accept raw test data and produce finished results. The equations used in preparation of original graphs and tables were used if available and approximate equations were written for those not available. Graphs of the approximations are shown in the appendix and test data should be checked for applicability of the approximations.

Mass Rate of Air Flow. The mass rate of air flow, \dot{m} , through an ASME square edged orifice, is given in the Power Test Code [7] as:

$$\dot{m} = 359 C F d^2 F_A Y \sqrt{\Delta P_0 \rho_0} \quad \text{lb}_m/\text{hr}$$

- where
- C = coefficient of discharge
 - F = velocity of approach factor
 - d = orifice diameter, in.
 - F_A = orifice thermal expansion factor
 - Y = net expansion factor
 - ΔP₀ = pressure differential across the orifice, in. H₂O
 - ρ₀ = specific weight of the air upstream of the orifice, lb_r/ft³

The ratio of the orifice diameter to the duct diameter is:

$$\beta = \frac{d}{D}$$

where $D =$ duct diameter

$$= 13.875 \text{ in.}$$

and the velocity of approach factor is:

$$F = \frac{1}{\sqrt{1 - \beta^4}}$$

The absolute duct pressure upstream of the orifice is given by:

$$P_o = P_b(0.490) - P_o(0.0361) \text{ psia}$$

where $P_b =$ barometric pressure, in. Hg

$P_o =$ duct pressure upstream of the orifice, in. H₂O
(duct pressure is below atmospheric pressure)

A dimensionless ratio of orifice pressure drop to orifice pressure is:

$$x = \frac{\Delta P_o(0.0361)}{P_o}$$

and the net expansion factor is then:

$$Y = 1.0 - \left(\frac{x}{1.4}\right)(0.41 + 0.35\beta^4)$$

The approximate equation for the orifice thermal expansion factor for type 304 stainless steel gives:

$$F_A = 1.0 + (t_o - 68)(1.85 \times 10^{-5})$$

The coefficient of discharge is an unknown in the equation but may be quickly iterated using an equation suggested by Murdock [6]. The equation is dependant upon the Reynolds number in the orifice, N_{Red} , and is:

$$C = C_o + \Delta C \left(\frac{10^4}{N_{Red}}\right)^{1/2}$$

The coefficients C_o and ΔC for applicable β 's from Murdock [6] and a suggested first iteration C are:

| β | C_o | ΔC | C |
|---------|---------|------------|--------|
| .15 | 0.59446 | 0.00945 | 0.5975 |
| .25 | 0.59483 | 0.01037 | 0.5966 |
| .45 | 0.59863 | 0.01543 | 0.6014 |
| .75 | 0.60480 | 0.05448 | 0.6128 |

The density of the air upstream of the orifice may be found from the equation of state of a perfect gas modified by a humidity correction factor which gives:

$$\rho_o = \frac{144 P_o X_m}{53.34 T_o}$$

where P_o = duct pressure upstream of the orifice, psia

T_o = temperature of air upstream of the orifice, $^{\circ}R$

X_m = humidity correction factor for density as given by Kays and London [4]

$$= \frac{(1 + H)}{(1 + 1.607 H)}$$

and H = humidity ratio, $lb_m H_2O/lb_m$ dry air

The dynamic viscosity, μ_o , for air at one atmosphere pressure is given in reference (1) as:

$$\mu_o = \frac{0.003527 T_{ok}^{3/2}}{T_{ok} + 110.4}$$

where T_{ok} = temperature of air in duct, $^{\circ}K$

The orifice Reynolds number may be found from:

$$N_{Red} = \frac{15.28 \dot{m}}{\mu_o d}$$

Heat Transfer Calculations. The unit conductance for thermal convection heat transfer as given by equation one in the theory section is:

$$h_a = \frac{1}{\eta_o} \left[\frac{1}{U} - A_a \left(\frac{1}{\eta_s A_s h_s} + \frac{l_w}{12 A_{wa} k_w} \right) \right]$$

- where
- h_a = unit conductance for thermal convection heat transfer to the air, BTU/(hr ft² °F)
 - η_o = total surface effectiveness for the air side
 - U = overall unit conductance, BTU/(hr ft² °F)
 - A_a = total heat transfer area on the air side, ft²
 - η_s = total surface effectiveness for the steam side
 - A_s = total heat transfer area on the steam side, ft²
 - h_s = unit conduction for thermal convection on the steam side, BTU/(hr ft² °F)
 - l_w = thickness of the wall parting the steam side from the air side, in.
 - A_{wa} = area of the wall on the air side, ft²
 - k_w = thermal conductivity of the wall, BTU/(hr ft² °F/ft)

The film coefficient for convection on the steam side, h_s , is unknown and must be estimated. Any reasonable estimate is considered adequate since a 50 percent error in the estimate results in about two percent error in h_a . A value of h_s equal to 2000 BTU/(hr ft² °F) has been used.

The specific heat of dry air may be considered constant and is assumed to be:

$$c_{pda} = 0.241 \text{ BTU}/(\text{lb}_m \text{ } ^\circ\text{F})$$

The humidity correction factor for the specific heat as given by Kays and London [4] is:

$$X_c = \frac{1 + 1.915H}{1 + H}$$

where H = humidity ratio, lb_m H₂O/lb_m dry air

and the corrected specific heat is then:

$$c_p = c_{pda} X_c \quad \text{BTU}/(\text{lb}_m \text{ } ^\circ\text{F})$$

The bulk average temperature in the test core is:

$$t_b = \frac{t_1 + t_2}{2} \quad ^\circ\text{F}$$

where t_1 = air temperature upstream of the test core, $^\circ\text{F}$

t_2 = air temperature downstream of the test core, $^\circ\text{F}$

and the film average temperature is then:

$$t_f = \frac{t_b + t_s}{2} \quad ^\circ\text{F}$$

where t_s = the saturation temperature corresponding to the arithmetic average steam pressure in the core, $^\circ\text{F}$

The number of heat Transfer Units may be found from the temperature NTU relation as given in the theory section, yielding:

$$\text{NTU} = \ln \left(\frac{t_s - t_1}{t_s - t_2} \right)$$

and the overall unit conductance is then:

$$U = \frac{c_p \dot{m} \text{NTU}}{A_a} \quad \text{BTU}/(\text{hr ft}^2 \text{ } ^\circ\text{F})$$

For most plate-fin type geometries the equation for the temperature effectiveness of a straight fin with constant conduction cross section may be used to a good approximation. [3]. The fin temperature effectiveness for the steam side, η_{fs} , is:

$$\eta_{fs} = \frac{\tanh(m_s l_s / 12)}{(m_s l_s / 12)}$$

where l_s = effective fin length for the steam side and is equal to one-half the total fin height, in.

$$m_s = \sqrt{\frac{24 h_s}{k_{fs} \delta_s}} \quad \text{ft}^{-1}$$

and $h_s = 2000 \text{ BTU}/(\text{hr ft}^2 \text{ } ^\circ\text{F})$ as previously estimated.

$k_{fs} =$ thermal conductance for the fin on the steam side, $\text{BTU}/(\text{hr ft}^2 \text{ } ^\circ\text{F}/\text{ft})$.

$\delta_s =$ fin thickness on the steam side, in.

The overall temperature effectiveness for the steam side, η_s , is then:

$$\eta_s = \frac{A_{ws} + \eta_{fs} A_{fs}}{A_s}$$

where $A_{ws} =$ wall area on the steam side, ft^2

$A_{fs} =$ fin area on the steam side, ft^2

$A_s =$ total heat transfer area on the steam side, ft^2

The fin temperature effectiveness for the air side, η_{fa} , is:

$$\eta_{fa} = \frac{\tanh(m_a l_a / 12)}{m_a l_a / 12}$$

where $l_a =$ effective fin length for the air side and is equal to one-half the total fin height, in.

$$m_a = \sqrt{\frac{24 h_a}{k_{fa} \delta_a}} \text{ ft}^{-1}$$

and $k_{fa} =$ thermal conductance for the fin on the air side, $\text{BTU}/(\text{hr ft}^2 \text{ } ^\circ\text{F}/\text{ft})$.

$\delta_a =$ fin thickness on the air side, in.

$h_a =$ film coefficient for convection on the air side. It may be taken equal to U for the first iteration $\text{BTU}/(\text{hr ft}^2 \text{ } ^\circ\text{F})$.

The overall temperature effectiveness for the air side, η_o , is given by:

$$\eta_o = \frac{A_{wa} + \eta_{fa} A_{fa}}{A_a}$$

where $A_{wa} =$ wall area on the air side, ft^2

$A_{fa} =$ fin area on the air side, ft^2

$A_a =$ total heat transfer area on the air side, ft^2

The air mass velocity in the core, G , is given by:

$$G = \frac{\dot{m}}{A_c} \text{ lb}_m/(\text{hr ft}^2)$$

where A_c = the free flow area of the core on the air side, ft^2

Stanton number in the core can now be evaluated as:

$$N_{St} = \frac{h_a}{G c_p}$$

The dynamic viscosity evaluated at the film average temperature and one atmosphere pressure as given by Hilsenrath [1] is:

$$\mu_f = \frac{0.003527 T_{fk}^{3/2}}{T_{fk} + 110.4} \text{ lb}_m/(\text{hr ft})$$

where T_{fk} = film average temperature, $^{\circ}\text{K}$

The dynamic viscosity evaluated at the bulk average temperature is:

$$\mu_b = \frac{0.003527 T_{bk}^{3/2}}{T_{bk} + 110.4} \text{ lb}_m/(\text{hr ft})$$

where T_{bk} = bulk average temperature, $^{\circ}\text{K}$

The thermal conductivity of air at the film average temperature and one atmosphere pressure as set forth by Hilsenrath [1] is:

$$k_f = \frac{0.001529 T_{fk}^{1/2}}{\left[1 + \frac{245.4}{T_{fk} \times 10^{12} / T_{fk}} \right]} \frac{\text{BTU}}{\text{hr ft}^2 \text{ } ^{\circ}\text{F}/\text{ft}}$$

Where T_{fk} = film average temperature, $^{\circ}\text{K}$

The Reynolds numbers evaluated at film average temperature and bulk average temperature are evaluated by:

$$N_{Re_f} = \frac{4r_h G}{\mu_f}$$

and

$$N_{Re_b} = \frac{4r_h G}{\mu_b}$$

where hydraulic radius r_h is defined by Kays and London [3] to be based on the free flow area and takes the form

$$r_h = \frac{A_c L}{A_s} \text{ ft}$$

where L = core flow length, ft

Prandtl number in the core is:

$$N_{Pr} = \frac{\mu_f c_p}{k_f}$$

where the fluid properties are evaluated at the film average temperature in the test core.

The Colburn-j heat transfer modulus is then:

$$j \equiv N_{St} N_{Pr}^{2/3}$$

which concludes the heat transfer calculations.

Friction Factor Calculations. The equation for the core friction factor as developed in equation two in the theory section may be written

as:

$$f = \frac{r_h \rho_m}{L} \left\{ \frac{\Delta P_c (4.3255 \times 10^9)}{G^2} - \left[\frac{K_c - (1 + \sigma^2)}{\rho_1} \right] - \left[\frac{K_e + 1 + \sigma^2 \left(1 + 4 \frac{\bar{r}_d l_d}{D_d} \right)}{\rho_2} \right] \right\}$$

- where
- r_h = core hydraulic radius, ft
 - ρ_m = mean density in the core lb_m/ft^3
 - L = core flow length, ft
 - ΔP_c = pressure drop across core, in. H_2O
 - G = core mass velocity, $\text{lb}_m/\text{hr ft}^2$

- K_c = contraction coefficient
 σ = the ratio of free flow area to frontal area
 ρ_1 = density of the air upstream of core, lb_m/ft^3
 K_e = expansion coefficient
 ρ_2 = density of the air downstream of core, lb_m/ft^3
 f_d = friction factor for the duct downstream of the core
 l_d = length of duct from the core to the downstream pressure tap, in.
 D_d = hydraulic diameter of the duct downstream of core, in.

The duct friction factor, f_d , is assumed constant at .015, a value corresponding to a nearly smooth pipe for a Reynolds number range of 100,000 to 500,000 as may be expected in the downstream duct.

The mean density in the case of heating is given by:

$$\rho_m = \frac{T_1 \rho_1 + T_2 \rho_2}{2} \left[\frac{1}{T_s - \left(\frac{T_1 - T_2}{NTU} \right)} \right] \text{lb}_m/\text{ft}^3$$

- where T_1 = upstream temperature, $^{\circ}\text{R}$
 T_2 = downstream temperature, $^{\circ}\text{R}$
 T_s = Saturation temperature corresponding to the average steam pressure in the core $^{\circ}\text{R}$

- ρ_1 = upstream density

$$= \frac{0.097318 X_m P_1}{T_1} \text{lb}_m/\text{ft}^3$$

- P_1 = upstream pressure, in. H_2O absolute

- X_m = humidity correction factor as previously given

- ρ_2 = downstream density

$$= \frac{0.09318 X_m P_2}{T_2} \text{lb}_m/\text{ft}^3$$

P_2 = downstream pressure, in. H₂O absolute

In the isothermal case, the mean density is equal to the arithmetic average density and since the temperature remains constant

$$\rho_m = \rho_{ave} = \frac{0.097318 X_m (P_1 + P_2)}{2T_1} \text{ lb}_m/\text{ft}^3$$

The equations for the contraction coefficient, K_c , and the expansion coefficient, K_e , are developed by Kays [2] and are given by

$$K_c = \frac{1 - 2C_c + C_c^2 (2K_d - 1)}{C_c^2}$$

and

$$K_e = 1 - 2K_d \sigma + \sigma^2$$

where K_d = velocity-distribution coefficient

$$\sigma = A_c/A_{fr}$$

C_c = jet contraction ratio

The jet contraction ratio is approximated as

$$C_c = 0.611 + 0.45 \sigma + 0.344 \sigma^{5.7}$$

The velocity-distribution coefficient K_d is dependent upon both core geometry and film Reynolds, N_{Ref} . The usual geometries used in plate fin type construction are:

square



triangular



For laminar flow, N_{Ref} less than 2000, Kays [2] gives the values

$$\text{square } K_d = K_{d_s} = 1.39$$

$$\text{triangular } K_d = K_{d_t} = 1.43$$

and for turbulent flow

$$\begin{aligned} \text{square} \quad K_d &= K_{d_s} = 1 + 1.17 (K_{d_c} - 1) \\ \text{triangular} \quad K_d &= K_{d_t} = 1 + 1.29 (K_{d_c} - 1) \end{aligned}$$

where the velocity-distribution coefficient for circular tubes, K_{d_c} , is given by:

$$K_{d_c} = 1.09068 (4f_m) + 0.0584 \sqrt{4f_m + 1}$$

and

$$f_m = 0.049 N_{Re_f}^{-0.2}$$

If the boundary layer is continually tripped, as in the case of louvered fin or off-set fin construction, film Reynolds number should be taken equal to infinity which yields $K_d = 1.0$ in all cases.

Heat Balance Calculations. The heat transfer rate to the air, Q air, is:

$$Q \text{ air} = \dot{m} c_p (t_2 - t_1) \text{ BTU/hr}$$

The total heat given up by the steam, Q steam, is equal to the heat given up by the excess steam as it passes through the core plus the heat given up by the condensate in the core.

$$Q \text{ steam} = \dot{s} (h_1 - h_{2g}) + \dot{w}_c (h_1 - h_{2f}) \text{ BTU/hr}$$

where s = mass rate of flow of excess steam, lb_m/hr

w_c = mass rate of flow of the condensate, lb_m/hr

h_1 = enthalpy of the steam at the top header pressure and temperature BTU/lb_m

h_{2g} = enthalpy of saturated steam at the bottom header pressure, BTU/lb_m

h_{2f} = enthalpy of saturated liquid at the bottom header pressure, BTU/lb_m

The mass rate of flow of the excess steam, \dot{s} , as measured by a square edged, standard ASME orifice with flange pressure taps is found from the

applicable equation given in the ASME Power Test Code [7]:

$$\dot{S} = 359 C_s F_s d_s^2 F_{As} Y_s \sqrt{\frac{P_s}{V_s}} \quad \text{lb}_m/\text{hr}$$

- where
- C_s = coefficient of discharge
 - F_s = velocity of approach factor
 - d_s = orifice diameter, in.
 - F_{As} = orifice thermal expansion factor
 - Y_s = net expansion factor
 - ΔP_s = pressure differential across the steam orifice, in. H₂O
 - V_s = specific volume of the steam passing through the orifice, ft³/lb_m

The velocity of approach factor, F_s , is:

$$F_s = \frac{1}{\sqrt{1 - \beta_s^4}}$$

where

$$\beta_s = \frac{d_s}{D_s}$$

- and
- D_s = steam pipe diameter
 - " 1.25 in.

The orifice thermal expansion factor is taken as constant corresponding to a steam temperature of 220 °F. For type 304 stainless steel

$$F_{As} = 1.00$$

The net expansion factor for steam, Y_s , is:

$$\text{where } Y_s = 1 - (0.41 + 0.35\beta_s^4)(x_s/1.3)$$

$$x_s = \Delta P_s / P_s$$

The upstream steam pressure, P_s , is taken as the saturation pressure corresponding to the upstream temperature and is given by the approximate

equation

$$P_s = 16.5 + (t_{s0} - 218)(0.376) \text{ psia}$$

The specific volume is given by the approximate equation:

$$v_s = 24.01 - 0.4(t_{s0} - 218) \text{ ft}^3/\text{lb}$$

The coefficient of discharge, C_s , is iterated by the same method that was used for the air orifice. The values of C_o and ΔC for applicable values of β_s are:

| β_s | d_s | $C_o = C_{os}$ | $\Delta C = \Delta C_s$ |
|-----------|----------|----------------|-------------------------|
| .56 | .700 in. | .6085 | .025 |
| .71 | .890 in. | .6090 | .041 |

and then

$$C_s = C_{os} + \Delta C_s \left(\frac{10^4}{N_{Resd}} \right)^{1/2}$$

The steam orifice Reynolds number, N_{Resd} , is:

$$N_{Resd} = \frac{0.004244 \dot{S}}{\mu_s d_s}$$

and the dynamic viscosity is given by the approximate equation:

$$\mu_s = 8.25 \times 10^{-6} + (t_{s0} - 200)(1.45 \times 10^{-8}) \frac{\text{lb}_m}{\text{ft sec}}$$

The enthalpy of the superheated steam in the top header is approximated by two equations, the first giving the variation with temperature at a constant pressure, $P_{s1} = 18.0$ psia and the second equation the variation with pressure. These equations are:

$$h'_{s1} = 1158.0 + (t_{s1} - 230.0) (.5) \text{ BTU/lb}_m$$

where h'_{s1} = enthalpy at 18.0 psia

t_{s1} = top header steam temperature, °F

$$\text{thence } h_{s1} = h_{s1}' - (P_{s1} - 18.0) (.35) \text{ BTU/lb}_m$$

where P_{s1} = steam pressure in top header, psia

The enthalpy of the saturated steam in the bottom header is found from the approximate equation:

$$h_{s2} = 1155.3 + (P_{s2} - 19.0) (.934) \text{ BTU/lb}_m$$

where P_{s2} = steam pressure in bottom header, psia

and the enthalpy of the condensate in the bottom header is:

$$h_c = 193.4 + (P_{s2} - 19.0) (2.64) \text{ BTU/lb}_m$$

The mass rate of flow of the condensate, w_c , is found by timing the condensate collected.

5. Evaluation

A steady state steam to air test was conducted on a compact heat exchanger manufactured by Hamilton Standard Corporation. The test core had the approximate dimensions of a six inch cube. The construction was the plane plate-fin type with flow passages between fins being approximately square. One side of the core was "straight," meaning that the flow passage was straight for the length of the exchanger. The other side was "ruffled," meaning that the flow passage was approximately a cosine curve. The plate spacing was 0.156 inches and the fin spacing was 18 fins per inch for both sides. All plate and fin material was 0.004 inch stainless steel. A set of "standard" curves for Colburn-j and friction factor vs. Reynolds number were supplied with the test core. The "standard" curves were for plate and fin spacing similar to the core tested.

The test was performed using the straight side of the core for air and the ruffled side for steam. The various components of the facility, the air system, steam system and instrumentation were checked out and proved to be very satisfactory. There was a problem in defining flow and

heat transfer areas for the exchanger because structural stiffeners had been placed at the end of each plate-fin passage. The stiffeners were placed at an angle across the flow path and thereby restricted the flow in the peripheral flow passages. This restriction would tend to increase with increasing flow rates. The test results based upon the minimum free flow area, which neglects the peripheral flow passages affected by the stiffeners, was plotted on the standard curves as shown in Fig. 6.

The next test should be on a heat exchanger core with previously determined characteristics and with given or definable geometry.

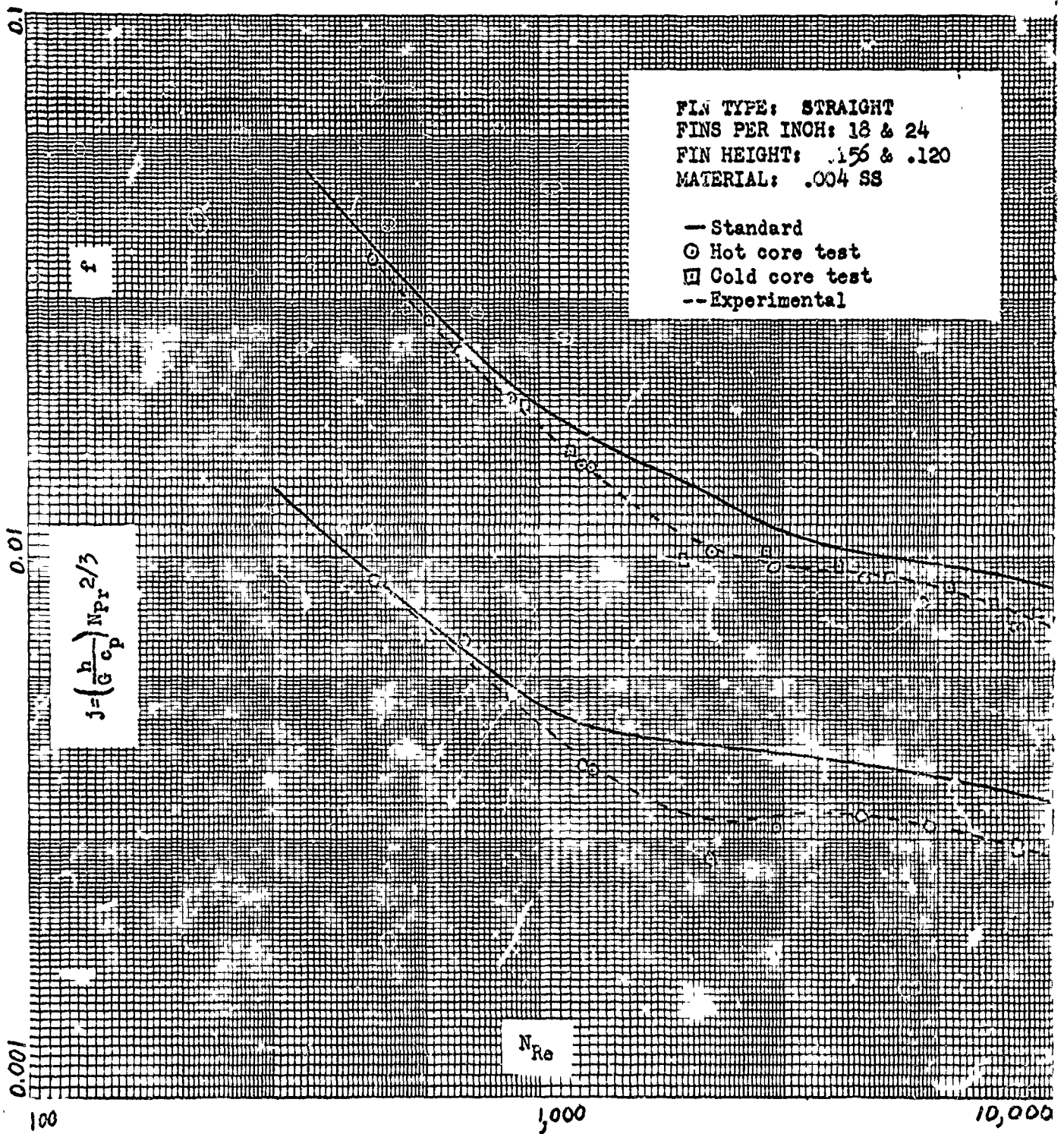

Figure 6. Colburn-j and friction factor vs. test core Reynolds number.

BIBLIOGRAPHY

1. Hilsenrath, J., et al. Tables of Thermodynamic and Transport Properties of Air, Argon, Carbon Dioxide, Carbon Monoxide, Nitrogen, Oxygen, and Steam. New York: Permigon Press, 1960.
2. Kays, W. M. Loss Coefficients for Abrupt Changes in Flow Cross Section with Low Reynolds Number Flow in Single and Multiple Tube Systems. Transactions ASME, v. 72, 1950: 1067 - 1074.
3. Kays, W. M. Description of Test Equipment and Method of Analysis for Basic Heat Transfer and Flow Friction Tests of High Rating Heat Exchanger Surfaces. TR No. 2, Department of Mechanical Engineering, Stanford University, Stanford, California, October 15, 1948.
4. Kays, W. M. and London, A. L. Compact Heat Exchangers. Second Edition. New York: McGraw-Hill, 1964.
5. Keenan J. H. and Keyes, F. G. Thermodynamic Properties of Steam. First Edition. New York: John Wiley and Sons, 1936.
6. Murdock, J. W. Tables for the Interpolation and Extrapolation of ASME Coefficients for Square - Edged Concentric Orifices. ASME paper, No. 64-WA/FM-6.
7. Power Test Code Supplements, Instruments and Apparatus, PTC-19.5.4 Flow Measurement, Chapter 4. New York: American Society of Mechanical Engineers, 1959.
8. Rouse, H. Elementary Mechanics of Fluids. New York: John Wiley and Sons, 1946.

APPENDIX I
OPERATING PROCEDURE

General. The preliminary check of instrumentation for both the hot core and cold core tests is the same.

The multipoint recorder should be allowed to warm up two hours prior to calibration. To calibrate the instrument, set the print mechanism to "Hold On" indicating any one of the points not used for a thermocouple. This open circuits the thermocouple measuring circuit. Place a D.C. millivolt source across the terminals at the back of the recorder and set the source to one millivolt. Adjust the recorder zero so that one millivolt is indicated. Set the source to nine millivolts and adjust the span so that nine millivolts are indicated. Repeat the zero and span adjustments until the recorder is calibrated.

All manometers should be adjusted for zero with the isolation valves open prior to lighting off the air or steam systems. The two steam header mercury manometers must be zeroed at about three inches due to the head of water between the manometers and the water pots. The water lines between the mercury manometers and the water pots are susceptible to the formation of air pockets which will cause erroneous readings.

Cold Core Test. In order to assure an even distribution of data points, the approximate pressure differential across the air orifice should be calculated for each run. Calculate the mass rate of air flow at a core Reynolds number of 500 and 10,000 and plot these two points on a log log plot. Divide the straight line connecting the points into equal increments, the number depending upon the desired number of runs. The orifice pressure differential may then be read from Fig. 7 for each mass rate of air flow.

Open all manometer valves and adjust for zero. Close all manometer valves prior to lighting off. Set the multipoint recorder to print the thermocouples in use by raising the corresponding buttons on "Selecto-Print." Turn the chart motor on and select the desired speed. Close the compressor blast gate (discharge valve) and energize the compressor motor. Open the blast gate to desired setting. Adjust the sliding plate valve for the desired air orifice pressure differential and observe instrumentation until steady state obtained.

Record the following data for each run:

1. Atmospheric pressure (0.001 in. Hg)
2. Atmospheric dry bulb temperature (0.1 °F)
3. Atmospheric wet bulb temperature (0.1 °F)
4. Air orifice size
5. Orifice upstream pressure (0.01 in. H₂O)
6. Orifice pressure differential (0.001 in. H₂O for $\Delta P_o < 3''$, and 0.01 in. H₂O for $\Delta P_o > 3''$)
7. Core upstream pressure (0.01 in. H₂O)
8. Core pressure differential (0.001 in. H₂O for $\Delta P_c < 3''$, and 0.01 in. H₂O for $\Delta P_c > 3''$).

9. Orifice air temperature (0.01 millivolt)
10. Core upstream air temperature (0.01 millivolt)

Items five through ten are recorded three times in the same sequence and averaged on the data sheet.

Hot Core Test. The instrumentation checks and the procedures for lighting off the air system are the same as for the Cold Core Test.

The steam system is activated by the following procedures. Obtain 100 psig low pressure air to the reducer central valves. Turn on the tap water supply for the condensate cooler and the desuperheater. Crack the desuperheater supply valve. Open the by-pass valves for the steam reducers and crack the steam stop valve. Allow the system to warm up slowly. When warm-up is completed close the by-pass valves and open the steam stop. Charge the first steam reducer to about 30 psig and the second to about six psig. Obtain a steam state in the top steam header of about six psig with five to ten degrees superheat by adjusting the first steam reducer and the desuperheater. The excess steam flow rate should be at least five times the condensate flow rate. Two steam orifice plates are provided; the larger to be used for high air flow rates. Condensate should be collected for at least five minutes at high air flow rates and for at least ten minutes at low air flow rates.

Steady state must be achieved before each run. This will require about one hour prior to the first run and 15 minutes between runs. Steady downstream core temperatures are the best indication of steady state.

The following data is recorded for each run:

1. Atmospheric pressure (0.001 in. Hg)
2. Atmospheric dry bulb temperature (0.1 °F)

3. Atmospheric wet bulb temperature (0.1 °F)
4. Air orifice size
5. Steam orifice size
6. Top steam header pressure (0.01 in. Hg)
7. Bottom steam header pressure (0.01 in. Hg)
8. Pressure differential across the steam orifice (0.01 in. Hg under H₂O)
9. Core upstream pressure (0.01 in. H₂O)
10. Core pressure differential (0.001 in. H₂O for $\Delta P_c < 3''$, and 0.01 in. H₂O for $\Delta P_c > 3''$)
11. Orifice pressure differential (0.001 in. H₂O for $\Delta P_o < 3''$, and 0.01 in. H₂O for $\Delta P_o > 3''$)
12. Orifice upstream pressure (0.01 in. H₂O)
13. Core upstream air temperature (0.01 millivolt)
14. Core downstream air temperature (0.01 millivolt)
15. Orifice air temperature (0.01 millivolt)
16. Top steam header temperature (0.01 millivolt)
17. Bottom steam header temperature (0.01 millivolt)
18. Steam orifice temperature (0.01 millivolt)
19. Condensate weight (0.1 lb)
20. Condensate collection time (1. sec)

Record items 6 through 18 three times in the same sequence and average on the data sheet.

The humidity ratio, H, may be found from a standard psychometric chart and convert temperatures to °F (0.1).

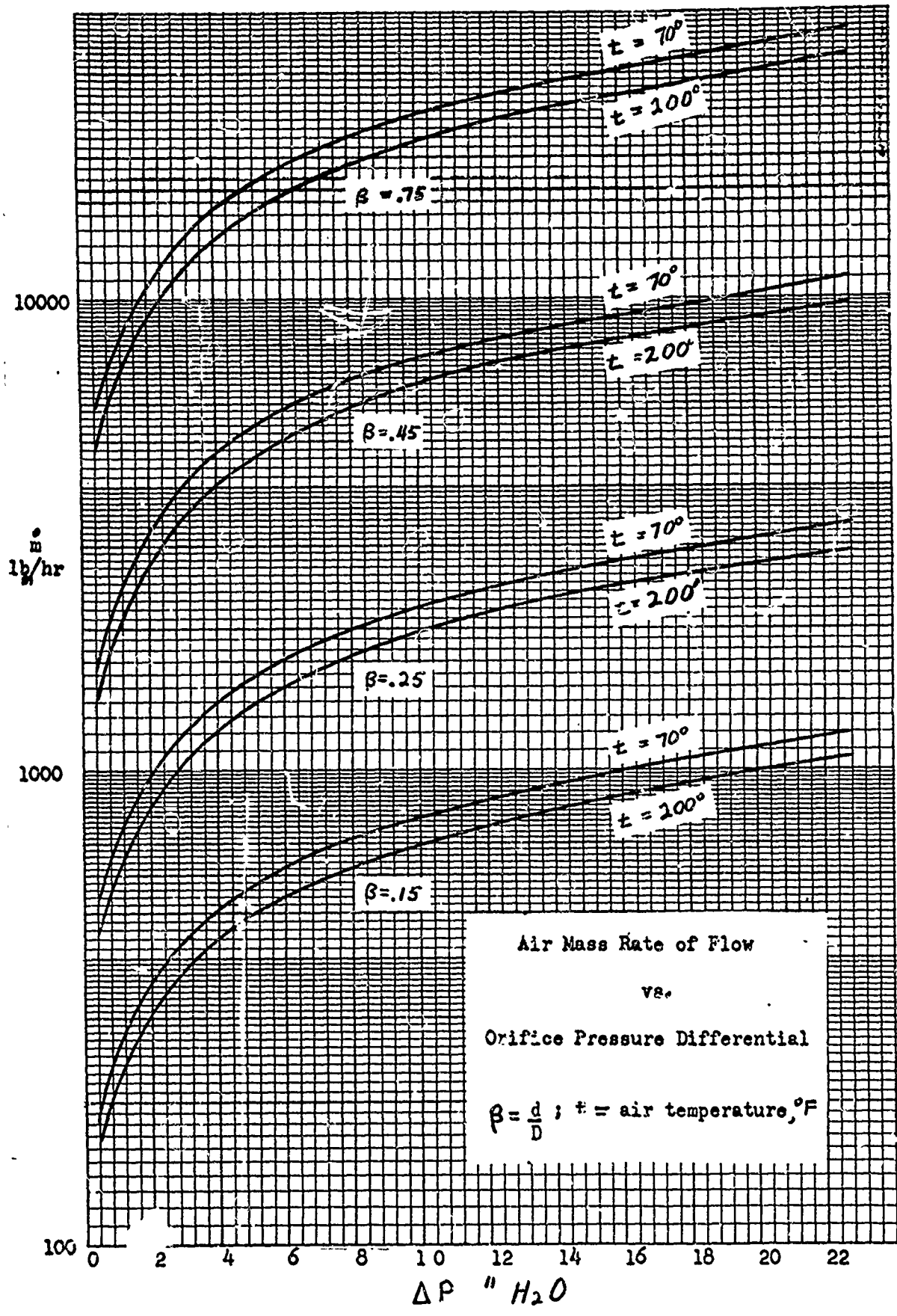

Figure 7. Mass rate of air flow vs. orifice pressure differential.

APPENDIX II

DIGIT/L COMPUTER PROGRAM FOR DATA REDUCTION

The program is designed to reduce data from both the hot core test and the cold core test. The program written in FORTRAN 60 and is shown on pages 52 through 57 and the output for the hot core test is shown on page 58 and that of the cold core test on page 59. The variables used in the program are defined in the program glossary. Variables not appearing in the glossary are internal to the program and are used to change dimension or to define special groupings to simplify programming.

The index used to reduce data from the hot core test or the cold core test is given by:

| | Program Index IHORC |
|----------------|------------------------|
| Hot core test | 1 |
| Cold core test | 2 |

The program is indexed to accept the various fin geometries normally used in plate fin construction and the indices are as follows:

| | Fin Geometry Index ISQTRIN |
|--------------------------------|-------------------------------|
| Square fin | 1 |
| Triangular fin | 2 |
| Louvered or off-set fin | 3 |
| ($N_{Re} = \text{infinity}$) | |

The indices used for the fluid metering orifices are:

| Air Orifice | Air orifice Index |
|-------------|-------------------|
| BETA | IB |
| d (in.) | |

| | | |
|---------------|----------|---------------------|
| .75 | 10.406 | 4 |
| .45 | 6.244 | 3 |
| .25 | 3.468 | 2 |
| .15 | 2.081 | 1 |
| Steam Orifice | | Steam Orifice Index |
| BS | ds (in.) | IBS |
| .71 | 0.890 | 2 |
| .56 | 0.700 | 1 |

The indices are all entered as fixed point constants. The number of runs, NOR, and the run number, NR, are entered as fixed point constants. All fixed point constants must be right justified in their data fields.

The constants for a given core such as areas, lengths, etc. are entered as input data only once and are the first three data cards beginning with AC and ending with DD. The fixed point constants for a particular series of runs, NOR, IHORC, ISQTRIN are entered on the fourth data card. The fifth through the seventh data cards are for run one, eighth through tenth for run two and so on. The first data card for a run contains the run fixed point constants, NR, IB, IBS. The second and third data cards for a run contain the run data beginning with H and ending with TC. When entering data for the cold core test, only the applicable data must be entered. All other data fields may be left blank.

The dimensions of input data must be those given in the program glossary and are the same as the raw data.

PROGRAM GLOSSARY

| Program Symbol | Program Unit | Nomenclature Symbol |
|----------------|--------------------------------|---------------------|
| AA | ft ² | A _a |
| AC | ft ² | A _c |
| ALFA | | |
| AFA | ft ² | A _{fa} |
| AFR | ft ² | A _{fr} |
| AFS | ft ² | A _{fs} |
| AKFM | BTU/(hr ft ² °F/ft) | K _{fm} |
| AS | ft ² | A _s |
| AWA | ft ² | A _{wa} |
| AWS | ft ² | A _{ws} |
| BETA | | β |
| BS | | β _s |
| C | | C |
| CC | | C _c |
| CO | | C _o |
| COLJ | | j |
| COS | | C _{os} |
| CP | BTU/(lb _m °F) | c _p |
| CRKD | | K _{dc} |
| CS | | C _s |
| DC | | ΔC |
| DCS | | ΔC _s |
| DD | in. | D _d |

| | | |
|-------|--------------------------------|--------------|
| DL | in. | ℓ_d |
| DPC | in. H ₂ O | ΔP_c |
| DPO | in. H ₂ O | ΔP_o |
| DPS | in. Hg under water | ΔP_s |
| DSO | in. | d_s |
| ERROR | | Error |
| FA | | F_A |
| FAS | | F_{As} |
| FB | | F |
| FBS | | F_s |
| FC | | f |
| FD | | f_d |
| FLA | in. | Q_a |
| FLL | ft | L |
| FLS | in. | Q_s |
| FKA | BTU/(hr ft ² °F/ft) | k_{fa} |
| FKS | BTU/(hr ft ² °F/ft) | k_{fs} |
| FM | | f_m |
| G | lbs/(hr ft ²) | G |
| H | lb/lb | H |
| HA | BTU/(hr ft ² °F) | h_a |
| HG | BTU/lb _m | h_c |
| HS | BTU/(hr ft ² °F) | h_s |
| HS1 | BTU/lb _m | h_{s1} |
| HS16 | BTU/lb _m | h_{s1} |
| HS2 | BTU/lb _m | h_{s2} |

| | | |
|---------|--|--------------------------------|
| IB | Index for air orifice diameter | |
| IBS | Index for steam orifice diameter | |
| IHORC | Index for Hot or Cold core test | |
| ISQTRIN | Index for fin geometry, square, triangular or infinite Reynolds number | |
| NOR | Number of runs | |
| NR | Run number | |
| OD | in. | d |
| P1 | in. H ₂ O | P ₁ |
| P2 | in. H ₂ O | P ₂ |
| PB | in. Hg | P _b |
| PO | in. H ₂ O | P _o |
| PR23 | | N _{pr} ^{2/3} |
| PS1 | in. Hg | P _{s1} |
| PS2 | in. Hg | P _{s2} |
| PSO | psia | P _{so} |
| Q AIR | BTU/hr | Q air |
| QSTM | BTU/hr | Qsteam |
| REB | | N _{Reb} |
| REFM | | N _{Ref} |
| REO | | N _{Red} |
| RESO | | N _{Resd} |
| RH | ft | r _h |
| RO1 | lb _m /ft ³ | ρ ₁ |
| RO2 | lb _m /ft ³ | ρ ₂ |
| ROAVE | lb _m /ft ³ | ρ _{ave} |

| | | |
|------|----------------------------------|----------------------------------|
| ROM | lb _m /ft ³ | ρ_m |
| ROO | lb _m /ft ³ | ρ_o |
| SDOT | lb _m /hr | s |
| ST | | \dot{w} |
| SQKD | | K_{d_s} |
| T1 | °F | t_1 |
| T2 | °F | t_2 |
| TB | °F | t_b |
| TC | min | time of condensate collection |
| TFA | in. | δ_a |
| TFM | °F | t_f |
| TFS | in | δ_b |
| TO | °F | t_o |
| TS | °F | t_s |
| TS1 | °F | t_{s1} |
| TS2 | °F | t_{s2} |
| TSO | °F | t_{so} |
| TRKD | | K_{d_t} |
| TW | in. | l_w |
| U | BTU/(hr ft ² °F) | U |
| UB | lb _m /(hr ft) | μ_b |
| UC | lb _m /(hr ft) | μ in core for cold core test |
| UFM | lb _m /(hr ft) | μ_f |
| UO | lb _m /(hr ft) | μ_o |
| USO | lb _m /(sec ft) | μ_s |

| | | |
|------|--|--------------------------------|
| VS | ft^3/lb_m | \checkmark_s |
| WC | lb_m | Weight of condensate collected |
| WCH | lb_m/hr | \dot{w}_c |
| WDOT | lb_m/hr | \dot{m} |
| WK | $\text{BTU}/(\text{hr ft}^{2\text{OF}}/\text{ft})$ | k_w |
| X | | x |
| XC | | X_c |
| SKD | | K_d |
| XM | | X_m |
| XMA | ft^{-1} | m_a |
| XMS | ft^{-1} | m_s |
| XNTU | | NTU |
| XS | | x_s |
| Y | | Y |
| YKE | | K_e |
| YNFA | | η_{fa} |
| YNFS | | η_{fs} |
| YNO | | η_o |
| YNS | | η_s |
| YS | | Y_s |
| ZKC | | K_c |

```

PROGRAM SSHEAT
O READ 1, AC, AFR, AA, AWA, AFA, AS, AWS, AFS, FLL, TFS, TFA, TW,
1FLA, FLS, FKA, FKS, WK, FD, DL, DD
1 FORMAT(8F10.0)
  READ 2, NOR, IHORC, ISQTRIN
2 FORMAT(3I10)
  GO TO (3,5), IHORC
3 PRINT 4
40FORMAT(1H1 25X,32H HEAT TRANSFER AND FRICTION DATA,///
1106H RUN MDOT G HUMID T1 P1 T2 DPC TS
2H BTU/ COLJ F FACT NRF NR B ERROR, //
3107H LB/HR LB/HR FT2 LB/LB F PSIA F PSI F H
4R FT2 F PERCENT, //)
  GO TO 7
5 PRINT 6
60FORMAT(1H1 25X,25H ISOTHERMAL FRICTION DATA,///
160H RUN MDOT G HUMID T1 P1 DPC F FACT NR, //
246H LB/HR LB/HR FT2 LB/LB F PSIA PSI, //)
7 READ 8, NR, IB, IBS
8 FORMAT (3I10)
O READ 9, H, OD, DSO, BETA, BS, TO, T1, T2, TS1, TS2, TSO,
1PB, PS1, PS2, DPS, P1, DPC, PO, DPO, WC, TC
9 FORMAT (8F10.0)
  PS1A=.490*(PB+PS1)
  PS2A=.490*(PB+PS2)
  PSAVE=(PS1A+PS2A)/2.
  TS=220.+(PSAVE-17.1)*2.66
  P2=P1+DPC
  TOR=T0+459.7
  TOK=TOR*5./9.
  UO=.003527*TOK**1.5/(TOK+110.4)
  GO TO (20,21,22,23 ), IB
20 CO=.59446
  DC=.00945
  C1=.5975
  OD=10.406
  BETA=.75
  GO TO 25
21 CO=.59483
  DC=.01037
  C1=.5966
  OD=6.244
  BETA=.45
  GO TO 25
22 CO=.59868
  DC=.01543
  C1=.6014
  OD=3.468
  BETA=.25
  GO TO 25
23 CO=.60480
  DC=.05448
  C1=.6128
  OD=2.081
  BETA=.15
25 C=C1
  B4=BETA**4
  POA=PB*.490-PO*.0361
  X=(DPO*.0361)/POA
  Y=1.-((.41+.35*B4)*X)/1.4)
  XM=(1.*H)/(1.+1.607*H)

```

```

ROO=POA*144.*XM/(53.3*TOR)
IF(TO-68.)12,12,11
11 FA=1.+(TO-68.)*1.85E-5
GO TO 13
12 FA=1.
13 FB=1./(1.-B4)**.5
DO 26 I=1,3
WDOT=359.*C*FB*FA*Y*OD*OD*SQRTF(DPO*ROO)
REQ=15,28 *WDOT/(UO*OD)
C=CO+DC*SQRTF(10000./REQ)
26 CONTINUE
GO TO (29,40),IHORC
29 TB=(T1+T2)/2.
TFM=(TB+TS)/2.
TBK=(TB+459.7)*5./9.
TFMK=(TFM+459.7)*5./9.
UB=.003527*TBK**1.5/(TBK+110.4)
UFM=.003527*TFMK**1.5/(TFMK+110.4)
AKFM=.001529*TFMK**.5/(1.+245.4/(TFMK*10.**12./TFMK))
RH=AC*FLL/AA
G=WDOT/AC
REFM=4.*RH*G/UFM
REB=4.*RH*G/UB
XC=(1.+1.915*H)/(1.+H)
CP=XC*.241
XNTU=LOGF((TS-T1)/(TS-T2))
U=CP*WDOT*XNTU/AA
HS=2000.
XMS=SQRTF(24.*HS/(FKS*TFM))
YNFS=(TANH(XMS*FLS/12.))/(XMS*FLS/12.)
YNS=(AWS+YNFS*AFS)/AS
HA=U
DO 30 I=1,3
XMA=SQRTF(24.*HA/(FKA*TFA))
YNFA=(TANH(XMA*FLA/12.))/(XMA*FLA/12.)
YNO=(AWA+YNFA*AFA)/AA
30 HA=1./(YNO*((1./U)-AA*(1./(YNS*AS*HS)+TW/(AWA*WK*12.))))
PR23=(UFM*CP/AKFM)**.667
ST=HA/(G*CP)
COLJ=ST*PR23
40 ALFA=AC/AFR
P1A=PB*13,571-P1
P2A=PB*13,571-P2
T1A=T1+459.7
T2A=T2+459.7
R01=.097318*XM*P1A/T1A
R02=.097318*XM*P2A/T2A
GO TO (41,42),IHORC
41 ROM=.5*((T1A*R01+T2A*R02)/(TS+459.7-((T2A-T1A)/XNTU)))
GO TO 43
42 ROAVE=.097318*XM*(P1A+P2A)/(2.*T1A)
ROM=ROAVE
G=WDOT/AC
RH=AC*FLL/AA
T1K=(T1+459.7)*5./9.
UC=.003527*T1K**1.5/(T1K+110.4)
REC=4.*RH*G/UC
REFM=REC
43 GO TO (50,45,44),ISQTRIN
44 XKD=1.
GO TO 60
45 IF(REFM-2000.)46,47,47

```

```

46 TRKD=1.43
GO TO 48
47 FM =.049*REFM**(-.2)
CRKD=1.09068*4.*FM+.05884*SQRTF(4.*FM)+1.
TRKD=1.+1.29*(CRKD-1.)
48 XKD=TRKD
GO TO 60
50 IF(REFM -2000.)51,53,53
51 SQKD = 1.39
52 GO TO 56
53 FM =.049*REFM**(-.2)
54 CRKD=1.09068*4.*FM+.05884*SQRTF(4.*FM)+1.
55 SQKD = 1.+1.17*(CRKD-1.)
56 XKD=SQKD
60 CC =.611+.045*ALFA +.344*(ALFA**5.7)
YKE=1.-2.*XKD*ALFA+ALFA**2.
ZKC=(1.-2.*CC+(CC*CC)*((2.*XKD)-1.))/(CC*CC)
A=(ZKC-(1.+ALFA*ALFA))/R01
B=(YKE+1.+ALFA*ALFA*(1.+(4.*FD*DL/DD)))/R02
FC= (RH*ROM/FLL)*((4.3255E+9*DPC/(G*G))-A-B)
P1AA = P1A*.0361
DPCA=DPC*.0361
GO TO (70,104),IHORC
70 GO TO (75,76),IBS
75 COS=.6090
DCS=.0410
DSO=.89
BS=.71
GO TO 77
76 COS=.6085
DCS=.0250
DSO=.7n
BS=.56
77 CS=.61
BS4=BS**4.
FBS=1./(1.-BS4)**.5
FAS=1.003
DPSO=.454*DPS
PSO=17.1+(TSO-220.)*.376
XS=DPSO/PSO
Y3=1.-(.41+.35*BS4)*(XS/1.3)
DPSW=DPSO/.0361
VS=24.01-(TSO-218.)*.4
USO=8.25E-6+(TSO-200.)*1.45E-8
DO 80 IS=1,3
SDOT=359.*CS*FSB*FAS*YS*DSO*DSO*SQRTF(DPSW/VS)
RESO=.004244*SDOT/(USO*DSO)
CS=COS+DCS*SQRTF(10000./RESO)
80 CONTINUE
HS18=1158.0+(TS1-230.)*.5
HS1=HS18-(PS1-18.0)*.35
HS2=1155.3+(PS2A-19.)*(.934)
HC=193.4+(PS2A-19.)*2.64
WCH=WC*60./TC
QAIR=WDOT*CP*(T2-T1)
QSTM=WCH*(HS1-HC)+SDOT*(HS1-HS2)
ERROR=(QAIR-QSTM)*100./QAIR
99 PRINT 100,NR,WDOT,G,H,T1,P1AA,T2,DPCA,TS,HA,COLJ,FC,REFM,REB,ERROR
1000FORMAT(I3,2X,F6.1,2X,F7.1,2X,F5.4,2X,F4.1,2X,F5.2,2X,F5.1,2X,F4.2,
12X,F5.1,2X,F4.1,3X,F6.5,2X,F6.5,2X,F6.1,2X,F6.1,2X,F5.1,/)
GO TO 110
104 PRINT 105,NR,WDOT,G,H,T1,P1AA,DPCA,FC,REFM

```

```
1050FORMAT(I3,2X,F6.1,2X,F7.1,2X,F5.4,2X,F4.1,2X,F5.2,2X,F4.2,2X,F6.5,  
12X,F6.1,//)  
110 IF(NR-NOR)7,112,112  
112 CONTINUE  
END
```

C DIMENSIONAL DATA FOR HEAT EXCHANGER, FIN TYPE--STRAIGHT,
 C 18 FINS PER INCH, FIN HEIGHT-0.156 INCHES, MATERIAL -0.004 SS

.091 .219 28.81 7.71 21.1 29.36 7.71 8.85 21.65
 .5 .004 .004 .078 .078 .078 8.85 8.85
 8.85 .015 12.6

STRAIGHT-18-.156

HOT CORE TEST

| TEST NO. | FIN HEIGHT | FIN THICKNESS | FIN SPACING | FIN HEIGHT | FIN THICKNESS | FIN SPACING | FIN HEIGHT | FIN THICKNESS | FIN SPACING | FIN HEIGHT | FIN THICKNESS | FIN SPACING | FIN HEIGHT | FIN THICKNESS | FIN SPACING | FIN HEIGHT | FIN THICKNESS | FIN SPACING | FIN HEIGHT | FIN THICKNESS | FIN SPACING | | | | | | | | | | |
|----------|------------|---------------|-------------|------------|---------------|-------------|------------|---------------|-------------|------------|---------------|-------------|------------|---------------|-------------|------------|---------------|-------------|------------|---------------|-------------|-------|-------|-------|-------|-------|-------|-------|-------|-------|-------|
| 1 | 1 | 1 | 1 | 220. | 236.2 | 229. | 30. | 30. | 2.814 | 9.49 | 12.9 | 10.05 | 11.167 | 9.54 | 9.915 | 9.09 | 8.867 | 9.8 | 10.566 | 9.1 | 8.234 | 9.36 | 10.45 | 10.18 | 6.083 | 10.62 | 9. | 10.78 | 5.918 | 11.15 | 5.333 |
| 2 | 1 | 1 | 1 | 212.8 | 239. | 222.5 | 30. | 30. | 3.3 | 10.05 | 11.167 | 9.54 | 9.915 | 9.09 | 8.867 | 9.8 | 10.566 | 9.1 | 8.234 | 9.36 | 10.45 | 10.18 | 6.083 | 10.62 | 9. | 10.78 | 5.918 | 11.15 | 5.333 | | |
| 3 | 1 | 1 | 1 | 203. | 238.9 | 221.3 | 30. | 30. | 3.3 | 10.05 | 11.167 | 9.54 | 9.915 | 9.09 | 8.867 | 9.8 | 10.566 | 9.1 | 8.234 | 9.36 | 10.45 | 10.18 | 6.083 | 10.62 | 9. | 10.78 | 5.918 | 11.15 | 5.333 | | |
| 4 | 1 | 1 | 1 | 188. | 239.5 | 220.5 | 30. | 30. | 3.3 | 10.05 | 11.167 | 9.54 | 9.915 | 9.09 | 8.867 | 9.8 | 10.566 | 9.1 | 8.234 | 9.36 | 10.45 | 10.18 | 6.083 | 10.62 | 9. | 10.78 | 5.918 | 11.15 | 5.333 | | |
| 5 | 2 | 2 | 2 | 186.5 | 236.1 | 220.5 | 30. | 30. | 4. | 10.05 | 11.167 | 9.54 | 9.915 | 9.09 | 8.867 | 9.8 | 10.566 | 9.1 | 8.234 | 9.36 | 10.45 | 10.18 | 6.083 | 10.62 | 9. | 10.78 | 5.918 | 11.15 | 5.333 | | |
| 6 | 2 | 2 | 2 | 162.1 | 232. | 219. | 30. | 30. | 4.5 | 10.05 | 11.167 | 9.54 | 9.915 | 9.09 | 8.867 | 9.8 | 10.566 | 9.1 | 8.234 | 9.36 | 10.45 | 10.18 | 6.083 | 10.62 | 9. | 10.78 | 5.918 | 11.15 | 5.333 | | |
| 7 | 2 | 2 | 2 | 167.4 | 232. | 219. | 30. | 30. | 7.6 | 10.05 | 11.167 | 9.54 | 9.915 | 9.09 | 8.867 | 9.8 | 10.566 | 9.1 | 8.234 | 9.36 | 10.45 | 10.18 | 6.083 | 10.62 | 9. | 10.78 | 5.918 | 11.15 | 5.333 | | |
| 8 | 3 | 3 | 3 | 164.1 | 228. | 218.3 | 30. | 30. | 8. | 10.05 | 11.167 | 9.54 | 9.915 | 9.09 | 8.867 | 9.8 | 10.566 | 9.1 | 8.234 | 9.36 | 10.45 | 10.18 | 6.083 | 10.62 | 9. | 10.78 | 5.918 | 11.15 | 5.333 | | |
| 9 | 3 | 3 | 3 | 156.2 | 228. | 218.3 | 30. | 30. | 8. | 10.05 | 11.167 | 9.54 | 9.915 | 9.09 | 8.867 | 9.8 | 10.566 | 9.1 | 8.234 | 9.36 | 10.45 | 10.18 | 6.083 | 10.62 | 9. | 10.78 | 5.918 | 11.15 | 5.333 | | |
| 10 | 3 | 3 | 3 | 160. | 239.5 | 215.1 | 30. | 30. | 8. | 10.05 | 11.167 | 9.54 | 9.915 | 9.09 | 8.867 | 9.8 | 10.566 | 9.1 | 8.234 | 9.36 | 10.45 | 10.18 | 6.083 | 10.62 | 9. | 10.78 | 5.918 | 11.15 | 5.333 | | |
| 11 | 3 | 3 | 3 | 149.5 | 240. | 215.1 | 30. | 30. | 9. | 10.05 | 11.167 | 9.54 | 9.915 | 9.09 | 8.867 | 9.8 | 10.566 | 9.1 | 8.234 | 9.36 | 10.45 | 10.18 | 6.083 | 10.62 | 9. | 10.78 | 5.918 | 11.15 | 5.333 | | |
| 12 | 3 | 3 | 3 | 149.1 | 240. | 215.1 | 30. | 30. | 8.2 | 10.05 | 11.167 | 9.54 | 9.915 | 9.09 | 8.867 | 9.8 | 10.566 | 9.1 | 8.234 | 9.36 | 10.45 | 10.18 | 6.083 | 10.62 | 9. | 10.78 | 5.918 | 11.15 | 5.333 | | |

C COLD CORE TEST STRAIGHT-18-.156

| C | COLD CORE TEST | 1 | 2 | 3 | 4 | 5 | 6 | 7 | 8 | 9 | 10 | 11 | 12 | 13 | 30.09 |
|--------|----------------|--------------|-------|-------|-------|---|---|---|---|---|----|----|----|----|-------|
| .00843 | 54. 2 3 | 53.5 2.35 | 60.28 | 60.9 | 10.0 | | | | | | | | | | 30.09 |
| .00843 | 54. 3 | 53.5 1.61 | 40.45 | 41.0 | 6.5 | | | | | | | | | | 30.09 |
| .00843 | 55. 3 | 54. 1.10 | 27.67 | 28. | 4.26 | | | | | | | | | | 30.09 |
| .00843 | 55. 3 | 54. .76 | 19.7 | 19.98 | 2.84 | | | | | | | | | | 30.09 |
| .00843 | 55. 3 | 54. .45 | 11.62 | 11.78 | 1.608 | | | | | | | | | | 30.09 |
| .00843 | 56. 2 | 55. .28 | 7.8 | 7.92 | 11.65 | | | | | | | | | | 30.09 |
| .00843 | 56. 2 | 55. .14 | 4.28 | 4.33 | 5.96 | | | | | | | | | | 30.09 |
| .00843 | 58. 2 | 56. .08 | 2.195 | 2.24 | 2.855 | | | | | | | | | | 30.09 |
| .00843 | 58. 1 | 56. .04 | 1.448 | 1.45 | 12.68 | | | | | | | | | | 30.09 |
| .00843 | 58. 1 | 56. .02 | 1.132 | 1.13 | 8. | | | | | | | | | | 30.09 |
| .00843 | 58. 1 | 56. .01 | .841 | .82 | 4.98 | | | | | | | | | | 30.09 |
| .00843 | 58. 1 | 56. .01 | .641 | .61 | 3.13 | | | | | | | | | | 30.09 |
| .00843 | 58. 1 | 56. .01 | .5 | .502 | 2.14 | | | | | | | | | | 30.09 |

HEAT TRANSFER AND FRICTION DATA

| RUN | MDOT LB/HR | G | HUMID LB/LB | T1 F | P1 PSIA | T2 F | DPC PSI | TS F | H BTU/ HR FT2 F | COLJ | F FACT | NRF | NR B | ERROR PERCENT |
|-----|---------------|---------|----------------|---------|------------|---------|------------|---------|--------------------|--------|--------|--------|--------|------------------|
| 1 | 350.2 | 3848.6 | .0080 | 58.1 | 14.70 | 220.0 | .02 | 225.9 | 10.7 | .00906 | .03518 | 477.9 | 503.4 | 7.8 |
| 2 | 512.6 | 5633.2 | .0080 | 56.0 | 14.70 | 212.8 | .04 | 226.7 | 11.9 | .00686 | .02400 | 701.1 | 741.1 | 11.8 |
| 3 | 649.8 | 7141.1 | .0080 | 55.0 | 14.70 | 203.0 | .05 | 226.0 | 12.1 | .00549 | .01984 | 891.8 | 946.0 | 16.9 |
| 5 | 874.5 | 9609.5 | .0080 | 54.8 | 14.70 | 188.0 | .07 | 225.4 | 12.3 | .00416 | .01489 | 1205.8 | 1285.5 | 23.2 |
| 5 | 911.6 | 10017.7 | .0080 | 52.9 | 14.70 | 186.5 | .08 | 226.3 | 12.4 | .00404 | .01487 | 1257.6 | 1343.1 | 25.5 |
| 6 | 1549.1 | 17023.5 | .0080 | 52.5 | 14.69 | 162.1 | .15 | 225.4 | 14.7 | .00280 | .01033 | 2153.9 | 2320.1 | 22.9 |
| 7 | 2089.2 | 22958.7 | .0080 | 52.6 | 14.69 | 167.4 | .26 | 225.8 | 22.5 | .00319 | .00965 | 2899.6 | 3117.7 | 27.5 |
| 8 | 3104.8 | 34119.1 | .0080 | 50.5 | 14.68 | 164.1 | .56 | 226.8 | 34.0 | .00324 | .00906 | 4313.3 | 4650.0 | 55.5 |
| 9 | 4095.7 | 45008.1 | .0080 | 49.0 | 14.67 | 160.0 | .92 | 227.4 | 44.6 | .00322 | .00815 | 5697.4 | 6157.1 | 53.1 |
| 10 | 6105.4 | 67092.8 | .0080 | 49.0 | 14.63 | 149.5 | 2.02 | 227.6 | 60.6 | .00294 | .00742 | 8518.6 | 9243.9 | 40.6 |
| 11 | 6186.8 | 67987.1 | .0080 | 50.0 | 14.63 | 149.1 | 2.08 | 228.1 | 60.3 | .00288 | .00742 | 8628.2 | 9363.3 | 39.9 |

ISOTHERMAL FRICTION DATA

| RUN | MDOT LB/HR | G LB/HR | HUMID FT2 LB/LB | TI F | PI PSIA | GPC PSI | F FACT | MR |
|-----|---------------|------------|--------------------|---------|------------|------------|--------|---------|
| 1 | 6900.7 | 75832.0 | .0084 | 53.5 | 14.66 | 2.18 | .00771 | 11158.7 |
| 2 | 5742.3 | 63101.7 | .0084 | 53.5 | 14.68 | 1.46 | .00786 | 9285.8 |
| 3 | 4737.1 | 52056.4 | .0084 | 54.0 | 14.70 | 1.00 | .00819 | 7654.3 |
| 4 | 3915.0 | 43021.6 | .0084 | 54.0 | 14.71 | .71 | .00881 | 6325.8 |
| 5 | 2982.1 | 32770.2 | .0084 | 54.0 | 14.73 | .42 | .00917 | 4818.5 |
| 6 | 2399.0 | 26362.8 | .0084 | 55.0 | 14.73 | .28 | .00966 | 3870.5 |
| 7 | 1732.0 | 19632.7 | .0084 | 55.0 | 14.74 | .15 | .01034 | 2794.3 |
| 8 | 1203.2 | 13222.4 | .0084 | 56.0 | 14.74 | .08 | .00986 | 1938.3 |
| 9 | 904.5 | 9939.9 | .0084 | 56.0 | 14.74 | .05 | .01208 | 1457.1 |
| 10 | 721.5 | 7929.1 | .0084 | 56.0 | 14.74 | .04 | .01559 | 1162.4 |
| 11 | 571.1 | 6275.5 | .0084 | 56.0 | 14.74 | .03 | .01510 | 920.0 |
| 12 | 453.7 | 4986.2 | .0084 | 56.0 | 14.74 | .02 | .02374 | 730.9 |
| 13 | 375.7 | 4128.7 | .0084 | 56.0 | 14.74 | .02 | .02746 | 605.2 |

APPENDIX III

GRAPHS FOR APPROXIMATE EQUATIONS

Graphs for the approximate equations used in the experimental method and equations section are given on the following pages.

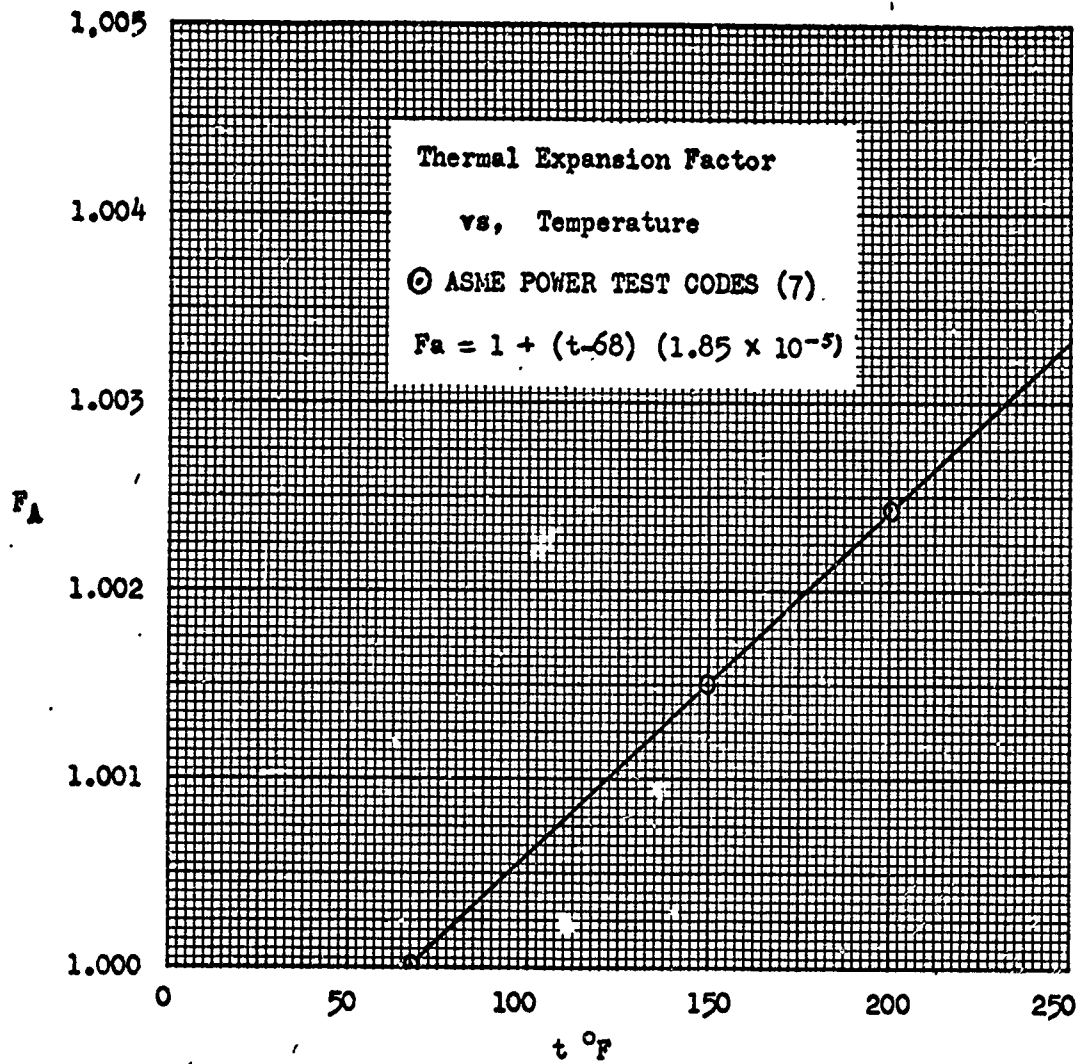

Figure 8. Thermal expansion factor vs. temperature.

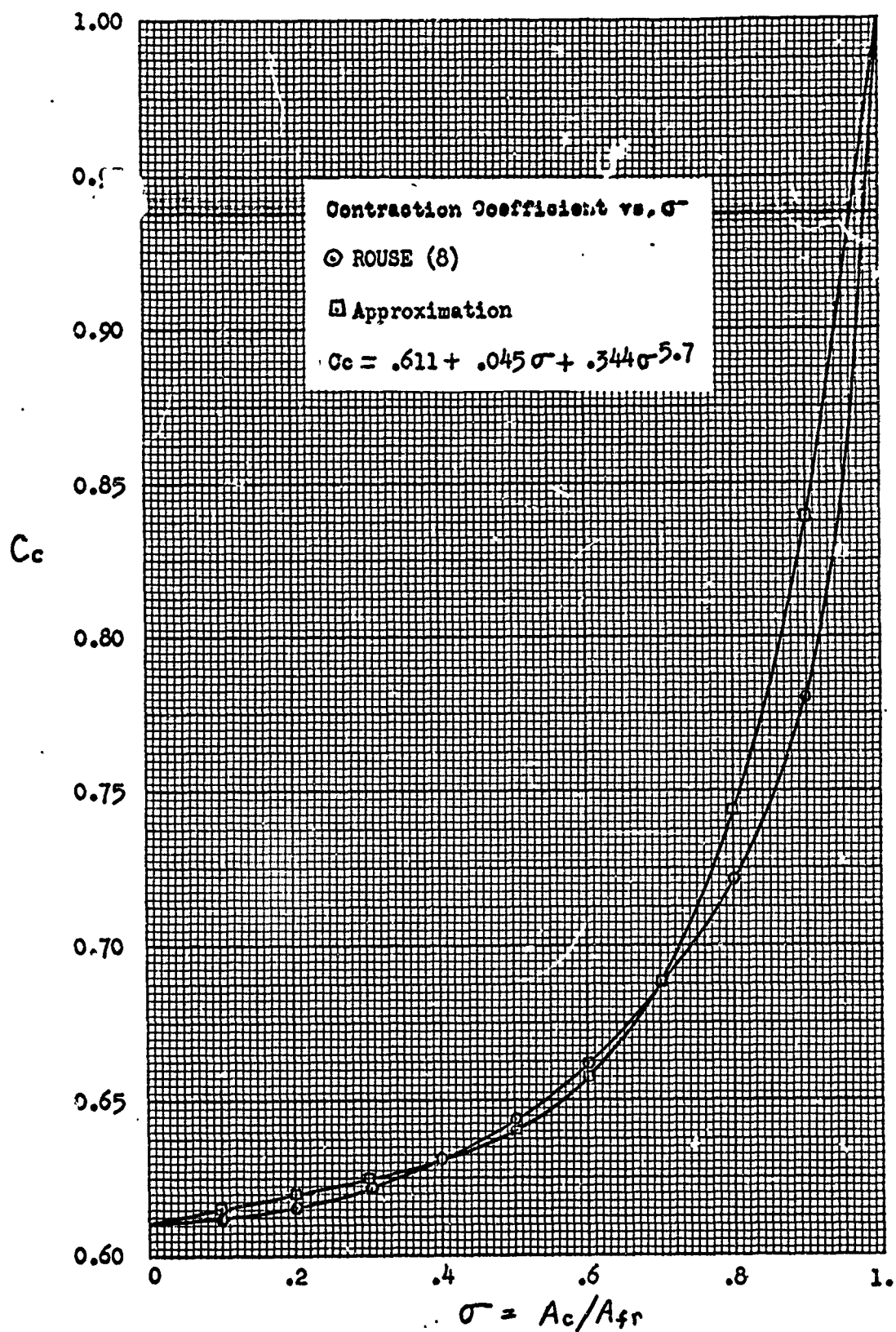

Figure 9. Contraction coefficient vs. σ

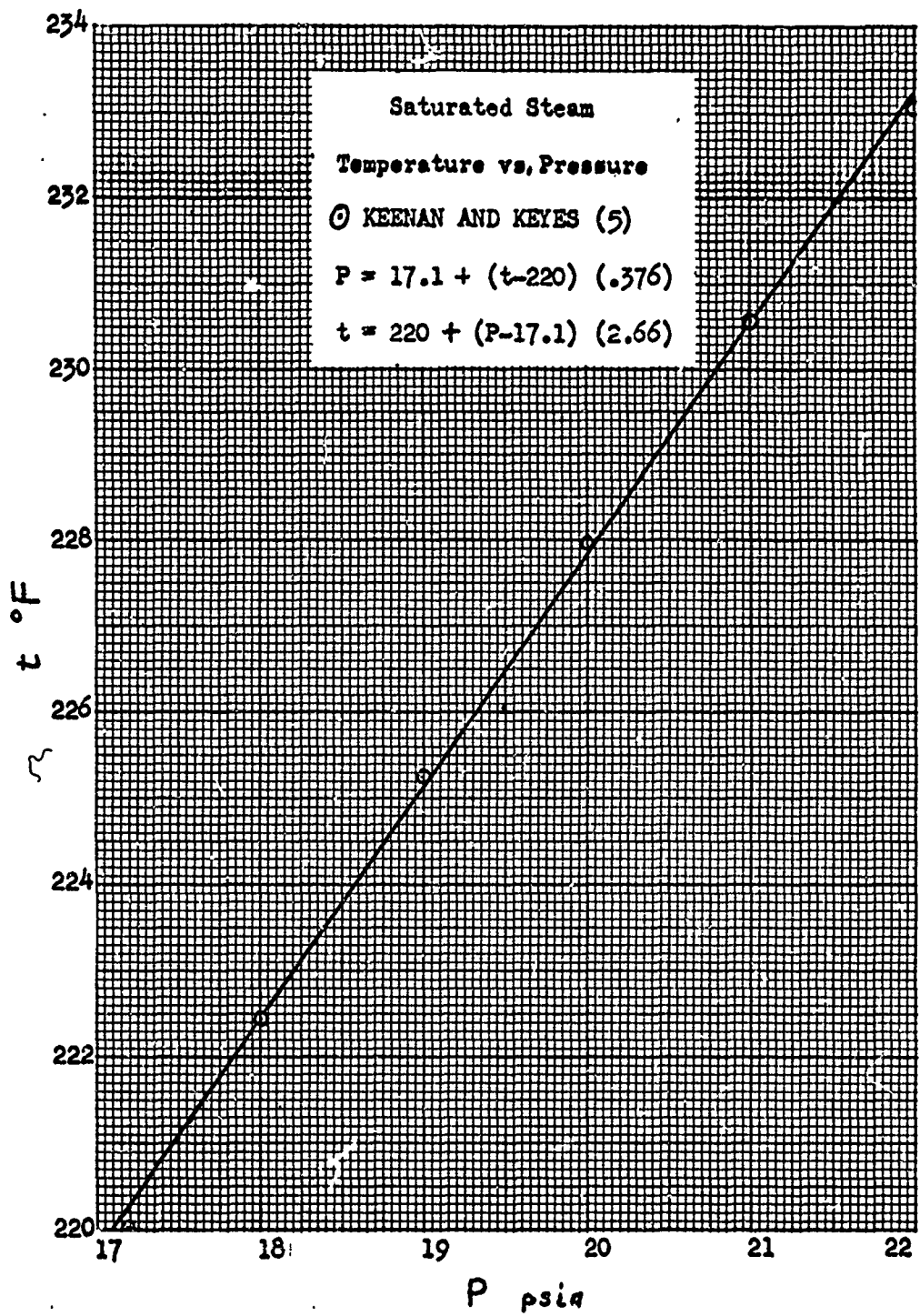

Figure 10. Saturated steam pressure vs. temperature.

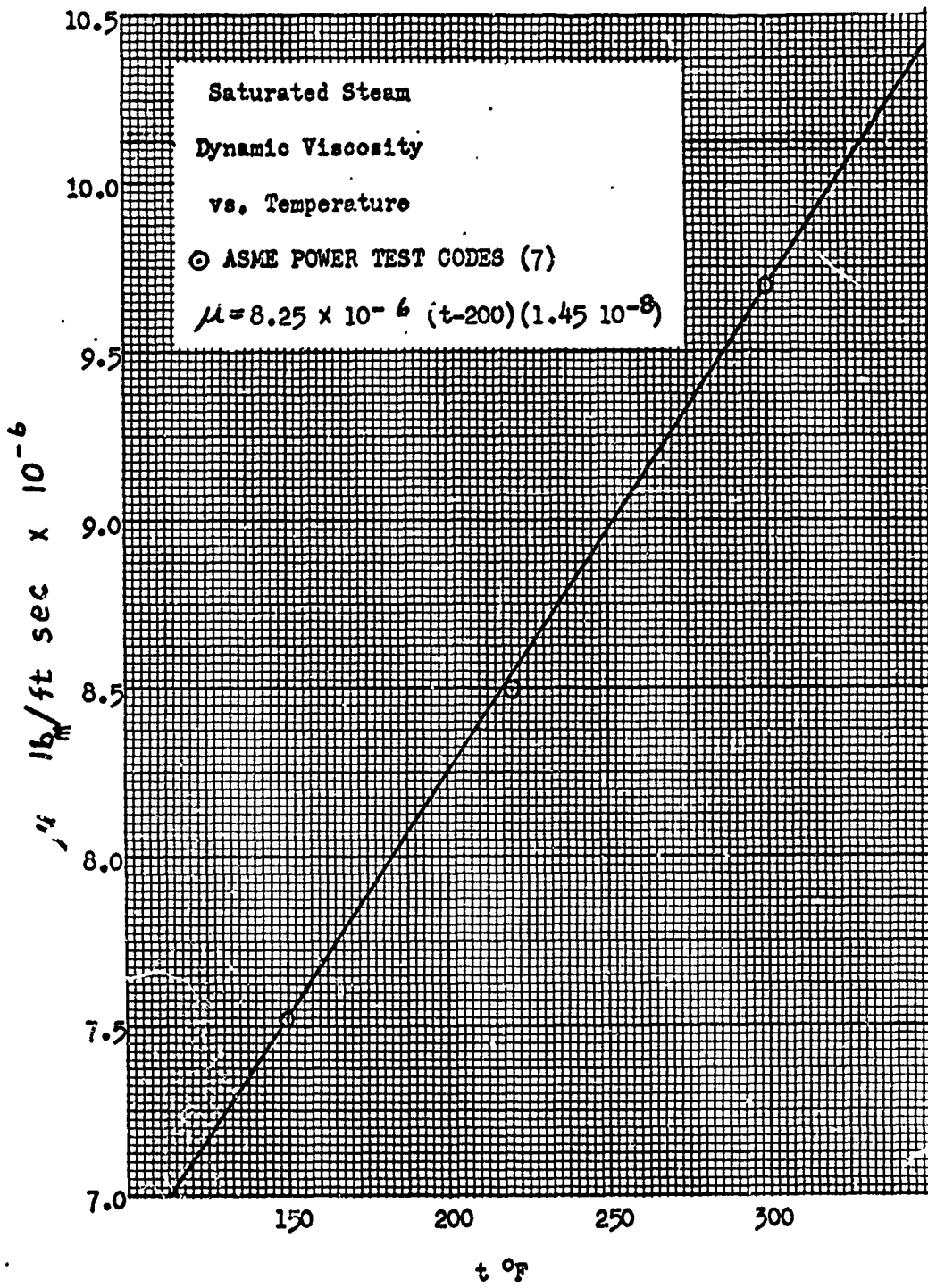

Figure 11. Saturated steam dynamic viscosity vs. temperature.

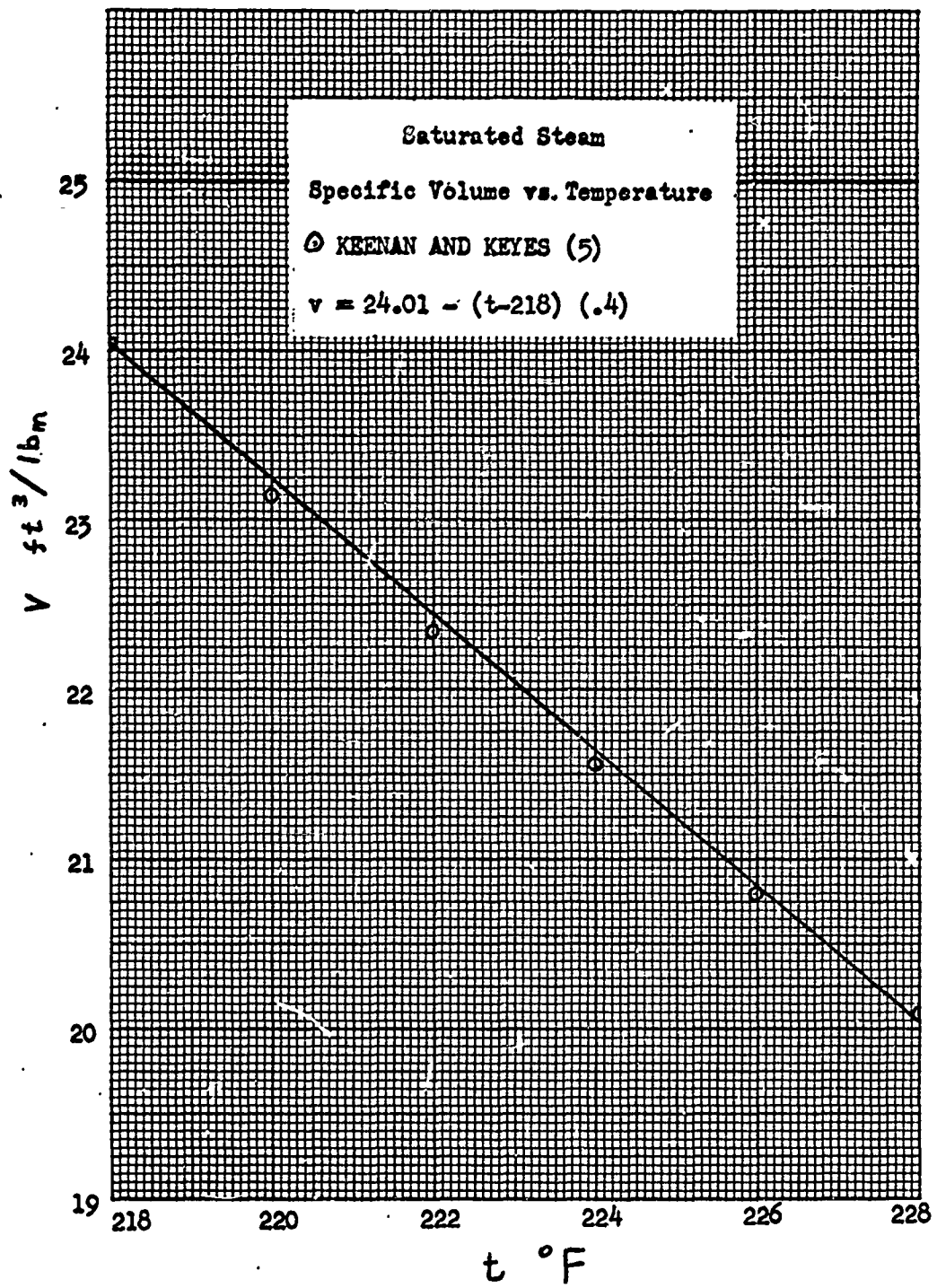

Figure 12. Saturated steam specific volume vs. temperature.

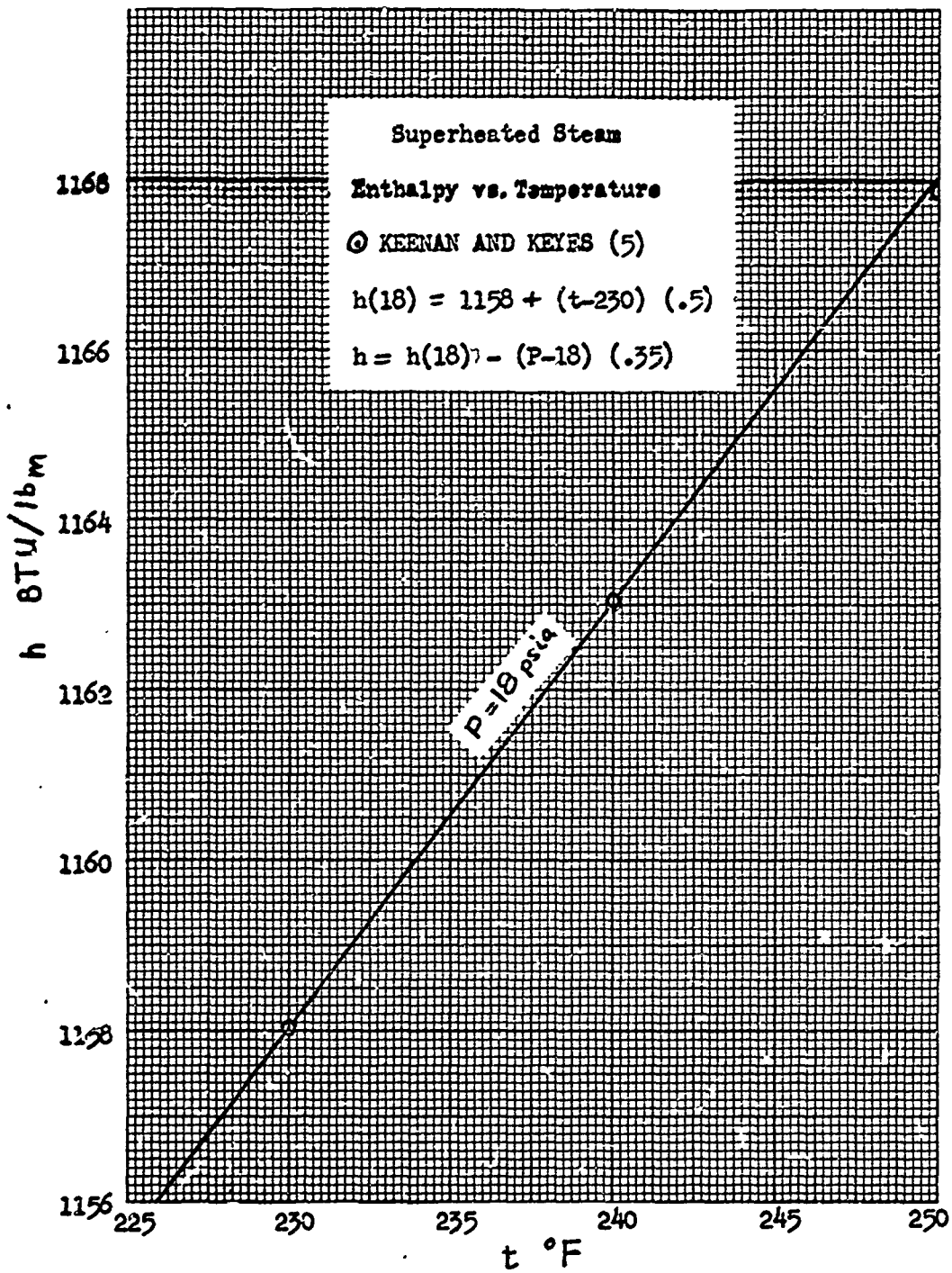

Figure 14. Superheated steam enthalpy vs. temperature.

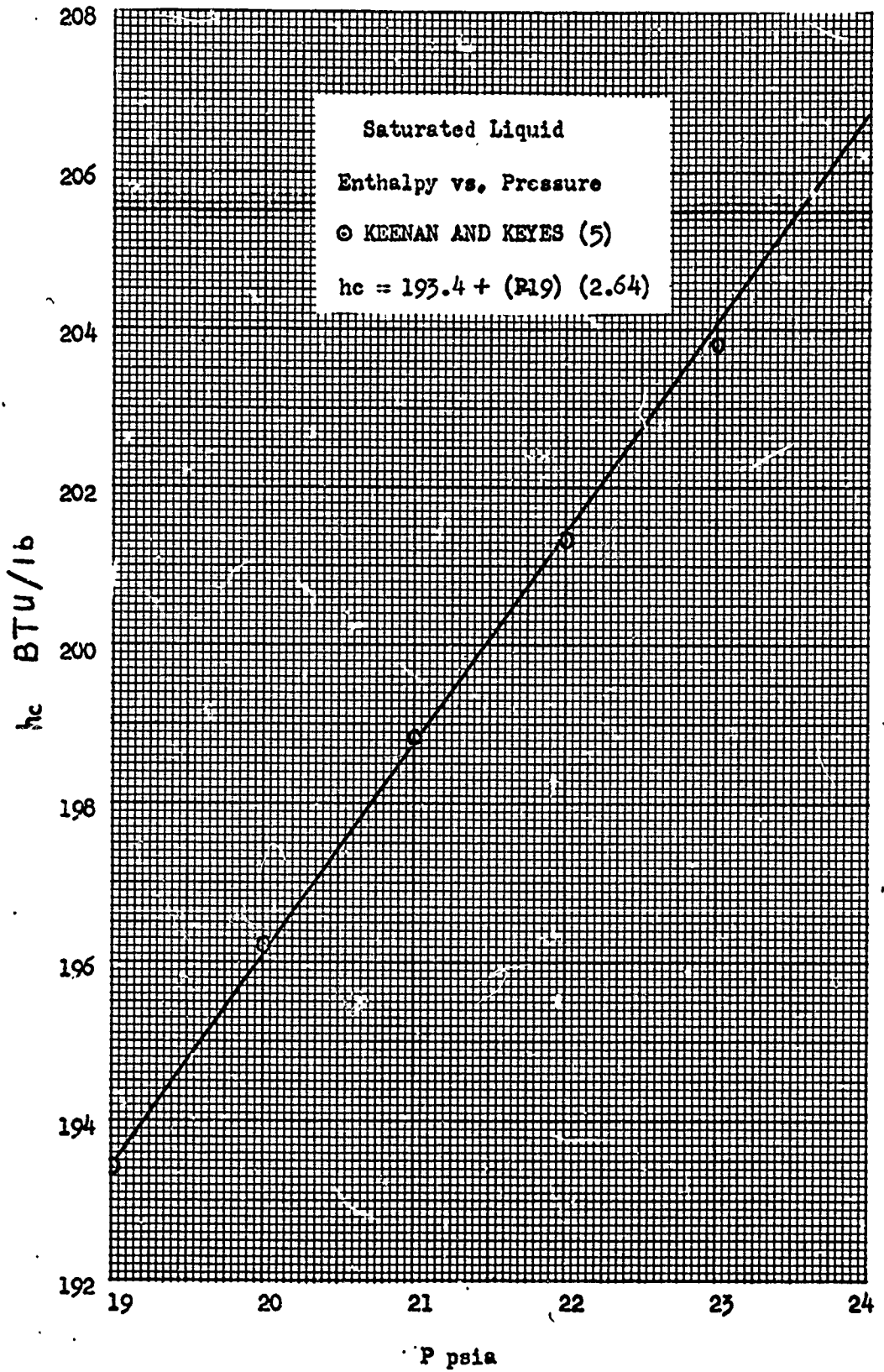

Figure 15. Saturated liquid enthalpy vs. pressure.