

UNCLASSIFIED

AD NUMBER

AD476309

LIMITATION CHANGES

TO:

Approved for public release; distribution is unlimited.

FROM:

Distribution authorized to U.S. Gov't. agencies and their contractors;
Administrative/Operational Use; MAR 1964. Other requests shall be referred to Space and Missile Systems Organization, Los Angeles, CA 90045.

AUTHORITY

SAMSO ltr, 17 Jan 1972

THIS PAGE IS UNCLASSIFIED

SSD-CR-64-32 Copy No.
143-210-64-1

476309

CONTRACT AF04(695)-435

PIBOL (Pilot-in-the-Booster-Loop) STUDY (U)

MARCH 1964

prepared by

MARTIN
DENVER

prepared for

HEADQUARTERS
SPACE SYSTEMS DIVISION
AIR FORCE SYSTEMS COMMAND
AIR FORCE UNIT POST OFFICE
LOS ANGELES, CALIFORNIA 90045

DDC
RECEIVED
JAN 21 1966
RECEIVED
TISA E

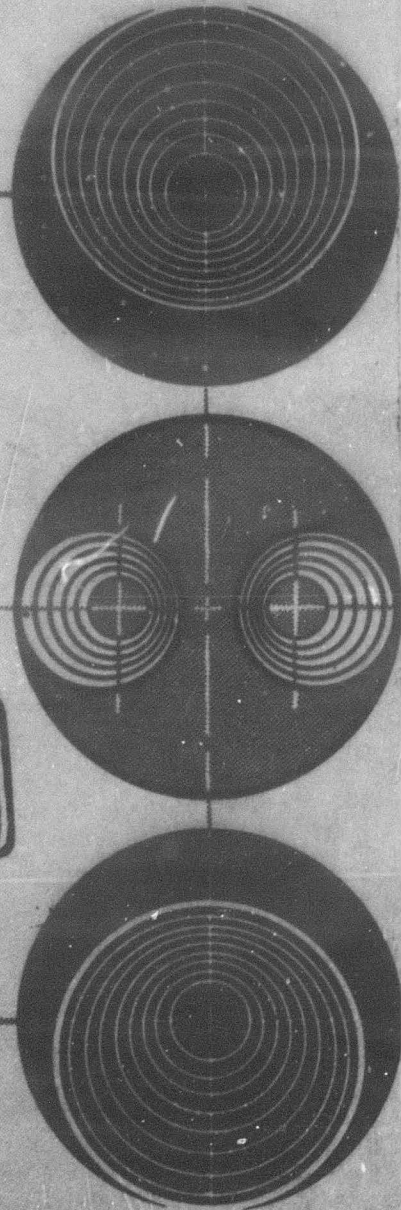

**Best
Available
Copy**

SSD-CR-64-32

Copy No. _____

Contract AF04(695)-435

PIBOL (PILOT-IN-THE-BOOSTER-LOOP)
STUDY (U)

March 1964

Author

D. L. Turner

Approved

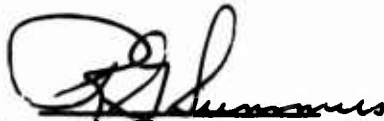

Chief of Advanced Upper Stages,
Titan III Applications and Growth

MARTIN COMPANY
Denver 1, Colorado
Aerospace Division of Martin Marietta Corporation

FOREWORD

This document is submitted in accordance with the requirements of Contract AF04(695)-435, Exhibit A, Paragraph 6.1.3.

This abstract is unclassified.

ABSTRACT

The purpose of this study was to determine if, and under what conditions, the Titan III launch vehicle could provide response characteristics necessary for piloted control (PIBOL) during powered flight.

This study determined the changes required to the Titan III system to provide these response characteristics, defined other hardware necessary for piloted control, compared the piloted system's reliability to that of the standard Titan III system, and determined the schedule and cost implications of PIBOL. This study did not evaluate the pilot's contribution to mission success.

The results of this study showed that the Titan III launch vehicle can provide the response requirements desired with a minimum change to the system configuration. At the same time, the effect of inertial guidance system failures is effectively eliminated, through the use of the pilot and the changes defined by this study.

CONTENTS

	<u>Page</u>
Foreword	ii
Abstract	iii
Contents	iv thru vii
I. Introduction	1
II. Summary	3
III. PIBOL Study Results	7
A. Theoretical Analysis	7
B. Airborne System Mechanization Studies	48
C. Reliability Analysis	67
D. PIBOL Ground Checkout Requirements	78
E. Logistics Considerations	84
F. Program Implementation	84
G. Specification Impact	107
IV. Conclusions and Recommendations	109
A. Conclusions	109
B. Recommendations	111
References	113
Appendix A -- Vehicle and Mission Data	A-1 thru A-10
Appendix B -- Second Order Approximation Methods	B-1 thru B-10
Appendix C -- Basic PIBOL Results	C-1 thru C-57
Appendix D -- Broader PIBOL Stage 0 Results	D-1 thru D-8

Appendix E -- Tolerance Considerations	E-1 thru E-8
Appendix F -- Hardware Specifications for New Equipment and Payload Interface Requirements	F-1 thru F-8
Appendix G -- Sample Reliability Calculations	G-1 thru G-4
Appendix H -- Other PIBOL Mechanization Concepts Considered	H-1 thru H-7
Appendix I -- Flight Control System Definition for Program 624A	I-1 thru I-14
Appendix J -- Stage 0 Roll Considerations	J-1 thru J-10

Distribution

Figure

1	Stage 0 Basic System, Pitch and Yaw Handling Characteristic Requirements (Displacement + Rate FCS)	10
2	Stage 0 Basic System, Pitch and Yaw Handling Characteristic Requirements (Displacement + Rate + Acceleration + Velocity FCS)	11
3	Stage 0 Broader System, Pitch and Yaw Handling Characteristic Requirements (Rate + Accelera- tion FCS)	12
4	Stage I Pitch and Yaw Handling Characteristic Requirements	13
5	Stage II Pitch and Yaw Handling Characteristic Requirements	14
6	Stage III Pitch and Yaw Handling Characteristic Requirements	15

7	Stage 0 Block Diagram - Basic PIBOL, Rate + Displacement + Acceleration + Velocity Flight Control System (Pitch Axis Shown)	20
8	Stage 0 Block Diagram - Basic PIBOL, Rate + Approximate Integral of Rate Flight Control System (Pitch Axis Shown)	21
9	Stage 0, Broader PIBOL Block Diagram, Rate + Acceleration Flight Control System (Pitch Axis Shown)	22
10	Handling Characteristics Stage 0, Pitch, Basic System Without Load Relief	28
11	Handling Characteristics Stage 0, Yaw, Basic System Without Load Relief	29
12	Handling Characteristics Stage 0, Pitch, Basic System with Load Relief	30
13	Handling Characteristics Stage 0, Yaw, Basic System with Load Relief	31
14	Basic System Handling Characteristics Stage 0, Pitch Axis, Rate + Approximate Integral of Rate Flight Control System	32
15	Basic System Handling Characteristics, Stage 0 Yaw Axis, Rate + Approximate Integral of Rate Flight Control System	33
16	Pitch and Yaw Stage I Handling Characteristics	35
17	Pitch and Yaw Stage II Handling Characteristics	36
18	Pitch and Yaw Stage III Handling Characteristics	37
19	Broader System Handling Characteristics Stage 0 Pitch Axis	40
20	Stage 0 Roll Axis Block Diagram	43
21	Basic System Handling Characteristic Variation due to Tolerances (Stage 0 Pitch Axis 60 sec Recommended System)	46
22	Broader System Handling Characteristic Variation Due to Tolerances (Stage 0, Pitch Axis, 60 sec)	47
23	Recommended PIBOL System Block Diagram	54
24	Present Titan III Configuration	55

25	Recommended Basic PIBOL Adapter-Programmer Configuration	56
26	Block Diagram - PIBOL Sequencer	59
27	PIBOL Sequencer Logic	60
28	Proposed PIBOL Equipment Locations	65 and 66
29	Logic Diagram, Mission Success Probability . . .	67
30	Minimum Required P_{PIBOL} for Given Values of P_{IGS} and P_{Switch}	70
31	Mission Success with and without PIBOL	75
32	Flights-Saved-Per-Thousand-Flights with PIBOL Backup vs Stage III Powered Flight/Coast Time . .	76
33	PIBOL Production Steps	87

Table

1	Recommended System Configuration	6
2	Pitch and Yaw Handling Characteristic Requirements	9
3	Roll Axis Handling Characteristic Requirements .	16
4	PIBOL Stability Margin Requirements	17
5	PIBOL Configurations Analyzed	26
6	Roll Channel Handling Characteristic Results . .	42
7	Representative Flight Sequence	50
8	Application Factors K_1 and Elapsed Time t_1 . . .	71
9	Failure Rates or Probabilities	73
10	Equipment to Mechanize Basic and Broader PIBOL .	74
11	Equipment to Transfer to PIBOL Mode	74
12	PIBOL Ground Checkout Methods	82
13	Summary of PIBOL Impact on OGE	83
14	Proposed 624A Phase III Booster Acceptance Schedule (Complete Out of VTF)	93
15	PIBOL Implementation Master Schedule	94

I. INTRODUCTION

The feasibility of a pilot contributing to the guidance and control function of the Titan III launch vehicle was initially investigated as part of the X-20A (Dyna-Soar) program, and was shown to be feasible if the launch vehicle provided certain defined response characteristics.

The subject of this document is a study undertaken by the Martin Company to determine if, and under what conditions, the Titan III launch vehicle can provide the response characteristics shown to be necessary by the X-20A investigation.

This study determined the changes to the Titan III flight control system configuration required to provide these response characteristics, and the hardware modifications and additions necessary to provide this configuration.

Another objective of the study was to determine the hardware modifications and additions required for the pilot to completely replace the booster inertial guidance system. In the Titan III vehicle, the guidance system not only provides the guidance and steering functions (which the pilot can replace as described above), but it also provides vehicle sequencing commands. As part of this study a vehicle sequencer was designed to provide these vehicle sequencing functions. Also, for the pilot to control the early phases of flight, a display showing lateral acceleration from the launch vehicle is required. The booster hardware to provide this display was also determined in this study. The acceleration display was the only one of the many displays required covered by this study.

The reliability of the hardware for the piloted system was calculated for comparison with the reliability of the standard Titan III launch vehicle.

The effect on cost and schedule of incorporating the required PIBOL modifications into the Titan III program was also evaluated.

Two methods of including piloted control for the pitch and yaw axes of control of the launch vehicle were directed by the contract to be studied. The first method used the pilot to provide the guidance and steering functions normally provided by the booster inertial guidance, and used the flight control system to provide the vehicle attitude reference. This system is

referred to as the Basic PIBOL system. The second method used the pilot to provide the guidance and steering functions, and the vehicle attitude reference. This system is referred to as the Broader PIBOL system.

All analysis and specific results of this study are peculiar to the Titan III/X-20A configuration. However, the major conclusions regarding feasibility are not restricted to this single booster payload combination.

This study did not consider any aspect of the pilot's performance, except that implied by the vehicle response characteristic requirements specified by the Air Force. In other words, the pilot's contribution to mission success was not evaluated; i.e., he is assumed to be 100% reliable. In addition, no consideration was given to the pilot's capability to sense Booster Inertial Guidance System failures, or to his ability to overcome the transients resulting from these failures.

II. SUMMARY

This study shows that the major task of providing the response requirements for a piloted vehicle occurs during the initial phases of flight, or during the period when the vehicle is encountering large aerodynamic forces. During other phases of flight, the response requirements can be attained with relative ease. Thus, for the Titan III/X-20A configuration, Stage 0 (the solid rocket motor phase of flight) provides the major design challenge for meeting pilot response requirements.

In evaluating the method for obtaining piloted control that uses the pilot to provide the guidance and steering functions and uses the flight control system to provide the vehicle attitude reference, satisfactory response characteristics were attainable for Stage 0 pitch and yaw operation by using either of the following two methods:

- 1) By using displacement gyros added to the vehicle to provide the vehicle attitude reference in conjunction with signals from the existing rate gyros as they are used in the standard Titan III flight control system;
- 2) By using an approximate integration of one of the existing rate gyros to provide the vehicle attitude reference in conjunction with signals from the existing rate gyros as they are used in the standard Titan III flight control system.

Although either of these systems provides the required response characteristics, the second of the two (using an approximate integration of rate) is the recommended system, because of its simpler hardware configuration, i.e., no displacement gyros are required.

Evaluation of the system for Stage 0 pitch and yaw operation, in which the pilot provides the guidance and steering function and the vehicle attitude reference, showed that this system could not be configured to meet the required response characteristics. The primary area of difficulty was obtaining desirable response with a nominal system in the frequency range that the pilot cannot control, i.e., the frequency range including the effects of structural bending. Additionally, this system was so sensitive to variations in the system parameters that instabilities could occur with minor variations in the system parameters.

Evaluation of the Stage 0 roll axis system showed that the response requirements could be attained by providing a heavily-filtered rate channel parallel to the rate channel existing in the standard Titan III/X-20A flight control system. The heavily-filtered rate channel is required to provide adequate low-frequency response without degrading the system response at the higher frequencies.

Evaluation of the pitch and yaw response characteristics of the upper stages (Stages I, II, and III) of Titan III showed that the response requirements are met with two flight control system configurations:

- 1) A system in which the rate channel gains are unchanged from the configuration used for the standard Titan III/X-20A configuration (without pilot control) and the displacement channel gains (using displacement gyros) are reduced to approximately 50% of the value used in the standard Titan III/X-20A configuration;
- 2) A system with standard Titan III/X-20A rate channel gains in Stage I and Stage II, with displacement channel gains set at zero for Stage I and Stage II (thus requiring no displacement gyros), and with both the rate and displacement channel gains set at zero for Stage III.

The second of these two systems, which requires the pilot to perform the guidance and steering function and also provide the vehicle attitude reference, is the recommended system for Stages I, II, and III pitch and yaw operation, because of the simpler hardware involved (again no displacement gyros required). For missions that involve more stringent Stage III handling characteristics than the X-20A, i.e., missions involving Stage III maneuvers, rate feedback would be necessary during Stage III pitch and yaw operation.

Roll axis operation for the Stage I and Stage II phases of flight meets the response requirements, with rate channel gains identical to those used in the standard Titan III/X-20A flight control system, and with the displacement channel gain set at zero.

To meet the Stage III roll axis requirements, a rate gyro for use during Stage III operation had to be added, since none is available in the standard Titan III vehicle.

A summary of the system configuration recommended to provide the desired vehicle response requirements is shown in Table 1.

The hardware required to incorporate the changes described in Table 1 is limited to changes to the existing adapter-programmer and the addition of a Titan III rate gyro package to Stage III.

Other hardware changes required to incorporate the piloted concept are the addition of the vehicle sequencer to provide the discrete commands normally issued by the booster inertial guidance system, the addition of a lateral acceleration sensing system to Stage I to provide the display of lateral acceleration, and the addition of a signal selector switch to switch the various functions from the standard Titan III flight mode to the piloted flight mode. Of these three devices, only the vehicle sequencer is new for Titan III. The lateral acceleration sensing system and the signal selector switch are identical to items presently being used in Titan III.

The entire system in the booster required to incorporate piloted control is referred to as the Pilot-In-the-Booster-Loop (PIBOL) system.

Ground checkout requirements for the PIBOL system were determined by this study, and were shown to be compatible with existing Titan III checkout equipment. Changes to incorporate PIBOL checkout are limited to additional interconnections, use of existing spare channels, and changes to the mission-dependent hardware (patchboards, programmer tapes, etc).

The PIBOL systems considered are shown to effectively eliminate booster inertial guidance system steering command failures, with the result that other components or systems (other than the guidance system) remain the limiting factors affecting probability of mission success. Mission success probability is shown to be much more sensitive to the reliability of the device used to transfer to the PIBOL mode than to the reliability of the components added for PIBOL. Consequently, redundant switching and redundant wiring are recommended to optimize any PIBOL system.

The time required from receipt of a hardware contract to PIBOL component availability (for installation in the vehicle) is approximately 10½ months. After installation of the PIBOL components, the schedule for subsequent vehicle production and test phases is unchanged from that required for a standard Titan III vehicle.

Table 1 Recommended System Configuration

Phase of Operation	Control System Configuration	Changes to Standard Titan III Configuration
Stage 0, Pitch and Yaw	Rate + Approximate Integral of Rate	Provide Integrators to Operate on Rate Gyro Signals, Disable Existing Displacement Channels
Roll	Rate Only	Provide Additional Rate Channel Gain, Disable Existing Displacement Channel
Stage I, Pitch, Yaw, and Roll	Rate Only	Disable Existing Displacement Channels
Stage II, Pitch, Yaw, and Roll	Rate Only	Disable Existing Displacement Channels
Stage III, Pitch and Yaw	Open Loop - No Rate, No Displacement	Disable Existing Displacement and Derived Rate Channels
Roll	Rate Only	Add Roll Rate Gyro

III. PIBOL STUDY RESULTS

Results of the PIBOL study are described in this chapter. These results include theoretical analysis, airborne mechanization studies, reliability analysis, PIBOL effects on ground hardware, logistics considerations, implementation plan, and specification impact.

A. THEORETICAL ANALYSIS

1. Requirements

Requirements for the PIBOL system can be divided into two categories:

- 1) Handling characteristics, which are requirements on the system response in the rigid-body or low-frequency region of operation;
- 2) Stability margin requirements, which apply in the frequency region including the effects of structural bending.

The requirements on rigid-body response were determined by The Boeing Company from the results of their Pilot-in-the-Booster-Control-Loop simulation study (Ref 1). These handling characteristics resulted from an evaluation of a pilot's capability to control the simulated flight of an early Titan III configuration, and from evaluation by various pilots of the acceptability of the vehicle response.

The stability margin requirements for PIBOL in the frequency range including the effects of structural bending, are identical to those required for the standard Titan III flight control system.

a. Handling Characteristic Requirements

Because of the way the handling characteristic requirements were determined on the Boeing simulator, they are related to the general configuration of the vehicle, the flight control system configuration, and the vehicle environment.

Therefore, the requirements vary during the different phases of flight, and also vary with the flight control system configuration.

The handling characteristic requirements for the pitch and yaw axes are expressed in terms of frequency and damping plots in which ω_n^2 (the square of the system natural frequency) is plotted against $2\zeta\omega_n$ (twice the product of the system damping ratio and the natural frequency). This method of specifying system requirements assumes that the transient characteristics of the vehicle (including flight control system) can be approximated by the second order equation,

$$S\theta(S) = \frac{K\omega_n^2}{S^2 + 2\zeta\omega_n S + \omega_n^2} \delta_c(S), \quad [1]$$

where

S = the Laplace operator,

$S\theta(S)$ = the Laplace transform of the vehicle attitude rate,

$\delta_c(S)$ = the Laplace transform of the pilot's command,

ω_n = the system natural frequency,

ζ = the system damping ratio,

K = the system gain.

Roll axis handling characteristic requirements are expressed as limitations on the flight control system channel gains as related to the vehicle parameters, thrust, roll moment of inertia, and roll moment arm.

The requirements for the pitch and yaw axes during the various phases of flight are shown in Fig. 1 thru 6 (Table 2 is included for indexing). Roll axis requirements are shown in Table 3.

Table 2 Pitch and Yaw Handling Characteristic Requirements

Configuration	Applicable PIBOL System Nomenclature	Applicable Requirements
Stage 0 - Rate + Integral of Rate (Displacement) Flight Control System	Basic	Fig. 1
Stage 0 - Rate + Integral of Rate + Acceleration + Integral of Acceleration (Velocity) Flight Control System	Basic	Fig. 2
Stage 0 - Rate + Acceleration Flight Control System	Broader	Fig. 3
Stage I - Rate + Integral of Rate or Rate Only Flight Control System	Basic or Broader	Fig. 4
Stage II - Rate + Integral of Rate or Rate Only Flight Control System	Basic or Broader	Fig. 5
Stage III - Rate + Integral of Rate or Rate Only Flight Control System	Basic or Broader	Fig. 6

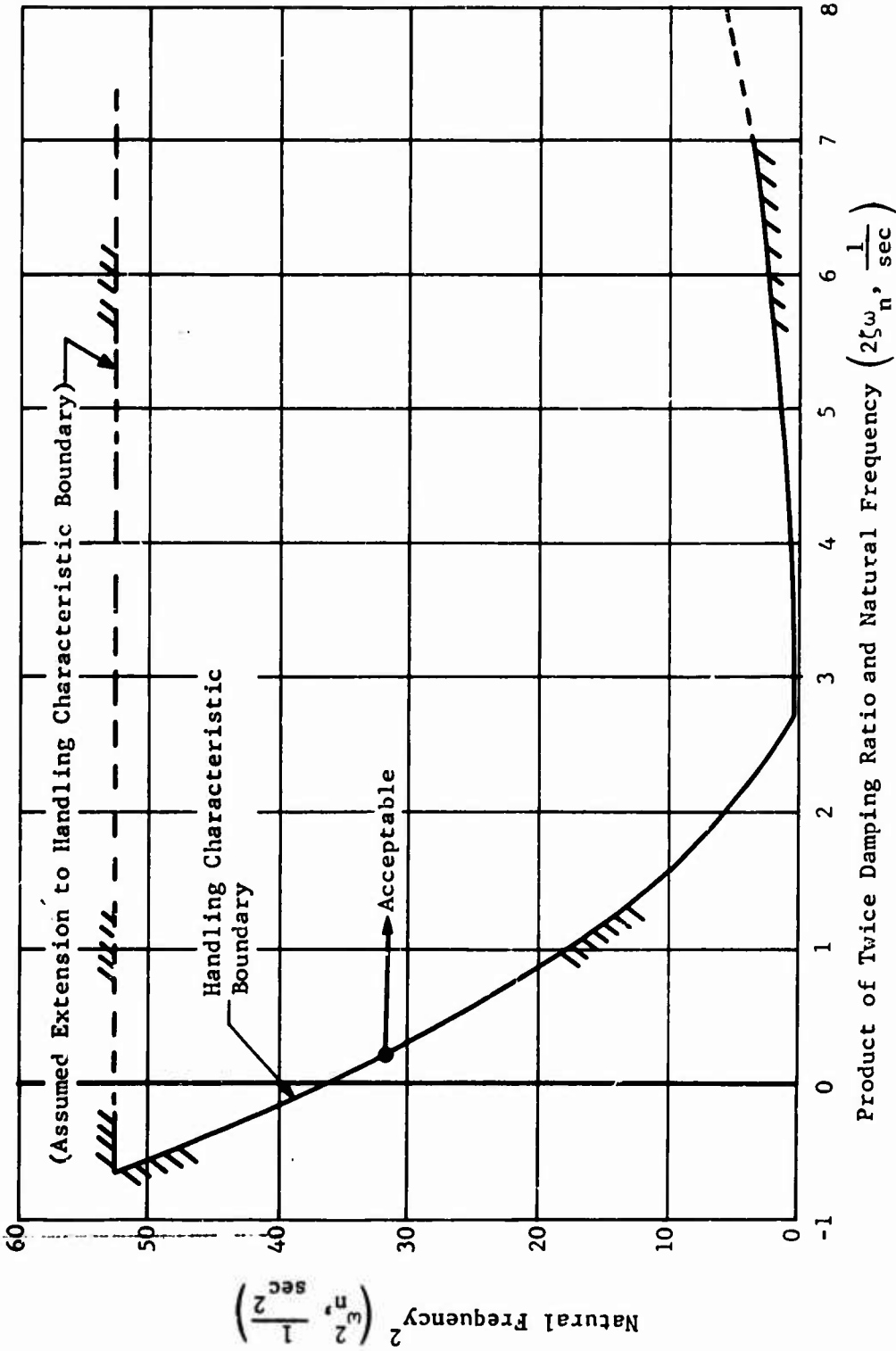

Fig. 1 Stage 0 Basic System, Pitch and Yaw Handling Characteristic Requirements (Displacement + Rate FCS)

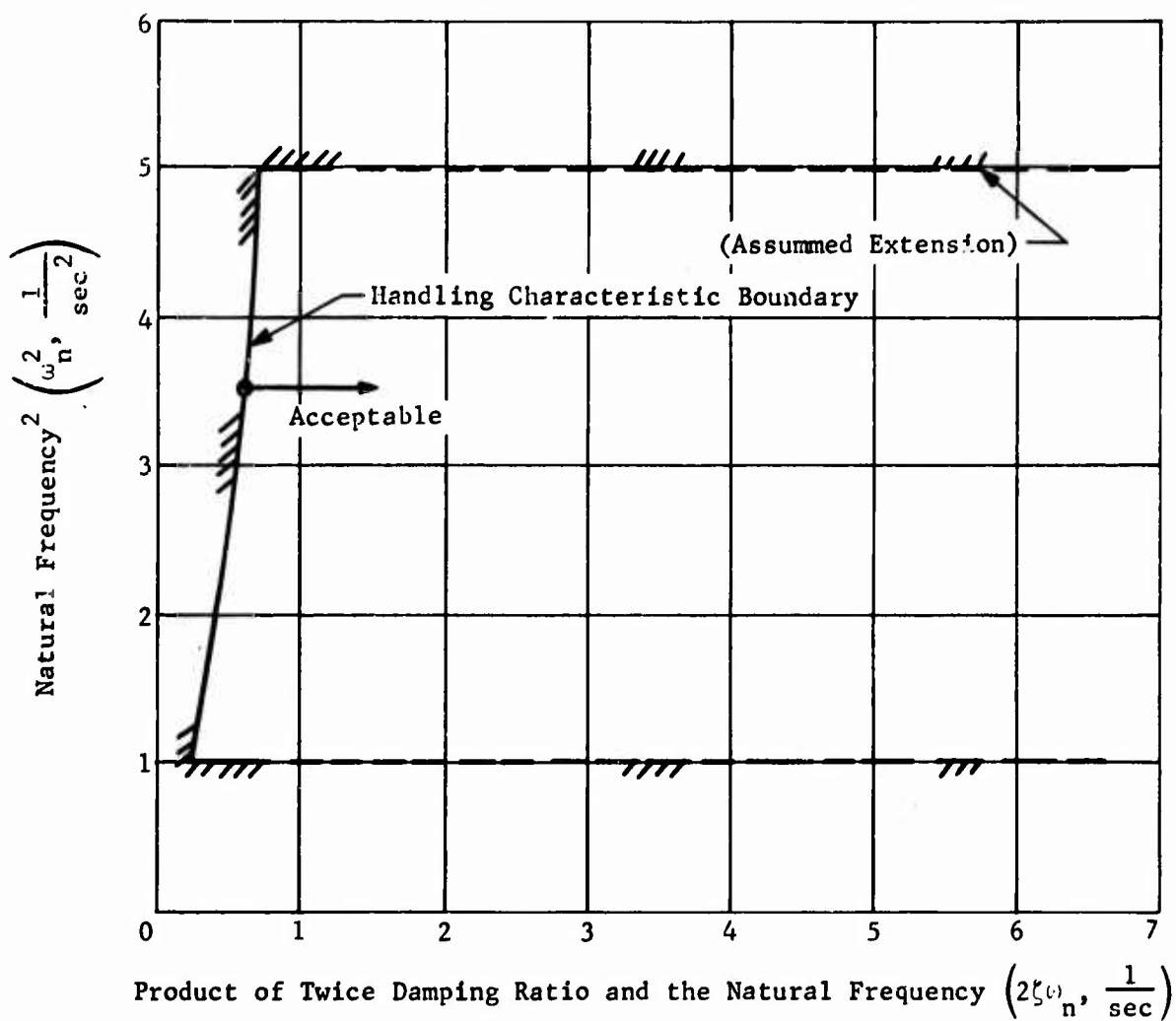

Fig. 2 Stage 0 Basic System, Pitch and Yaw Handling Characteristic Requirements (Displacement + Rate + Acceleration + Velocity FCS)

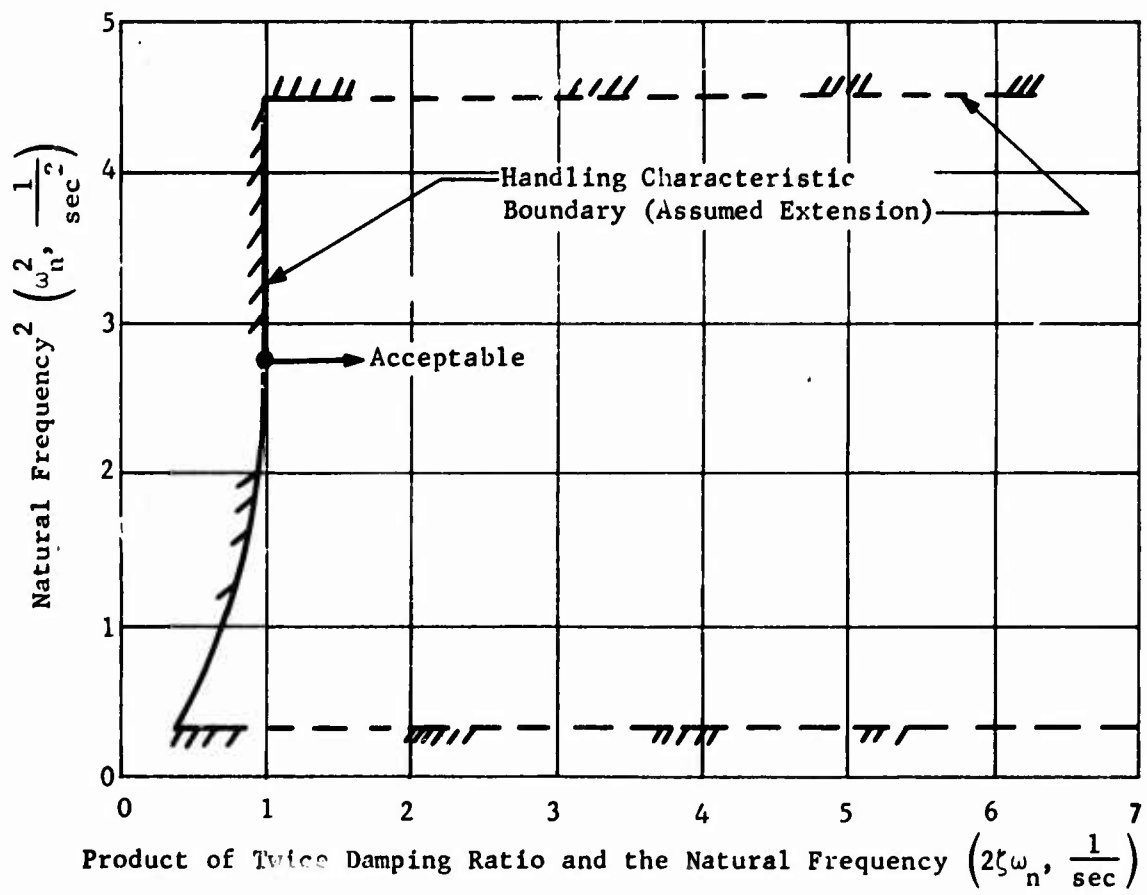

Fig. 3 Stage 0 Broader System, Pitch and Yaw Handling Characteristic Requirements (Rate + Acceleration FCS)

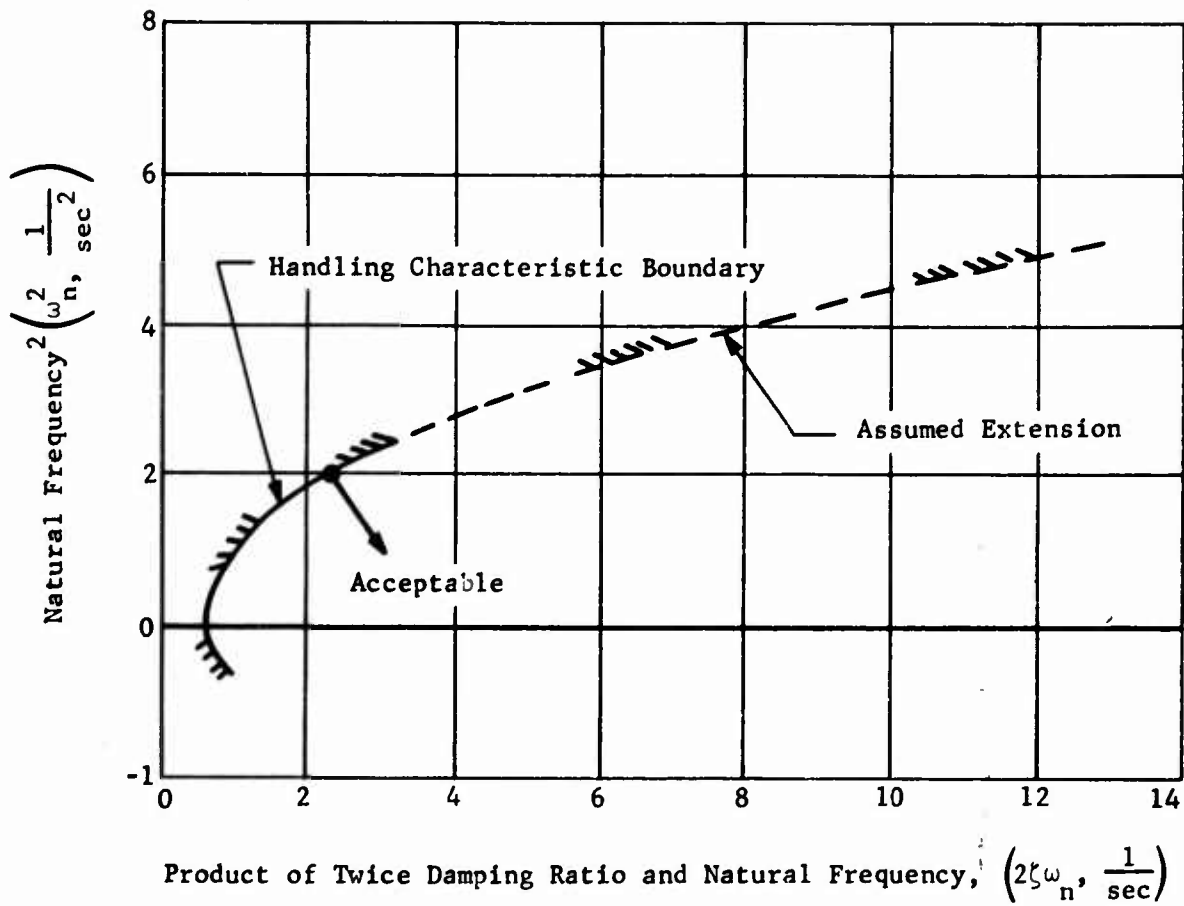

Fig. 4 Stage I Pitch and Yaw Handling Characteristic Requirements

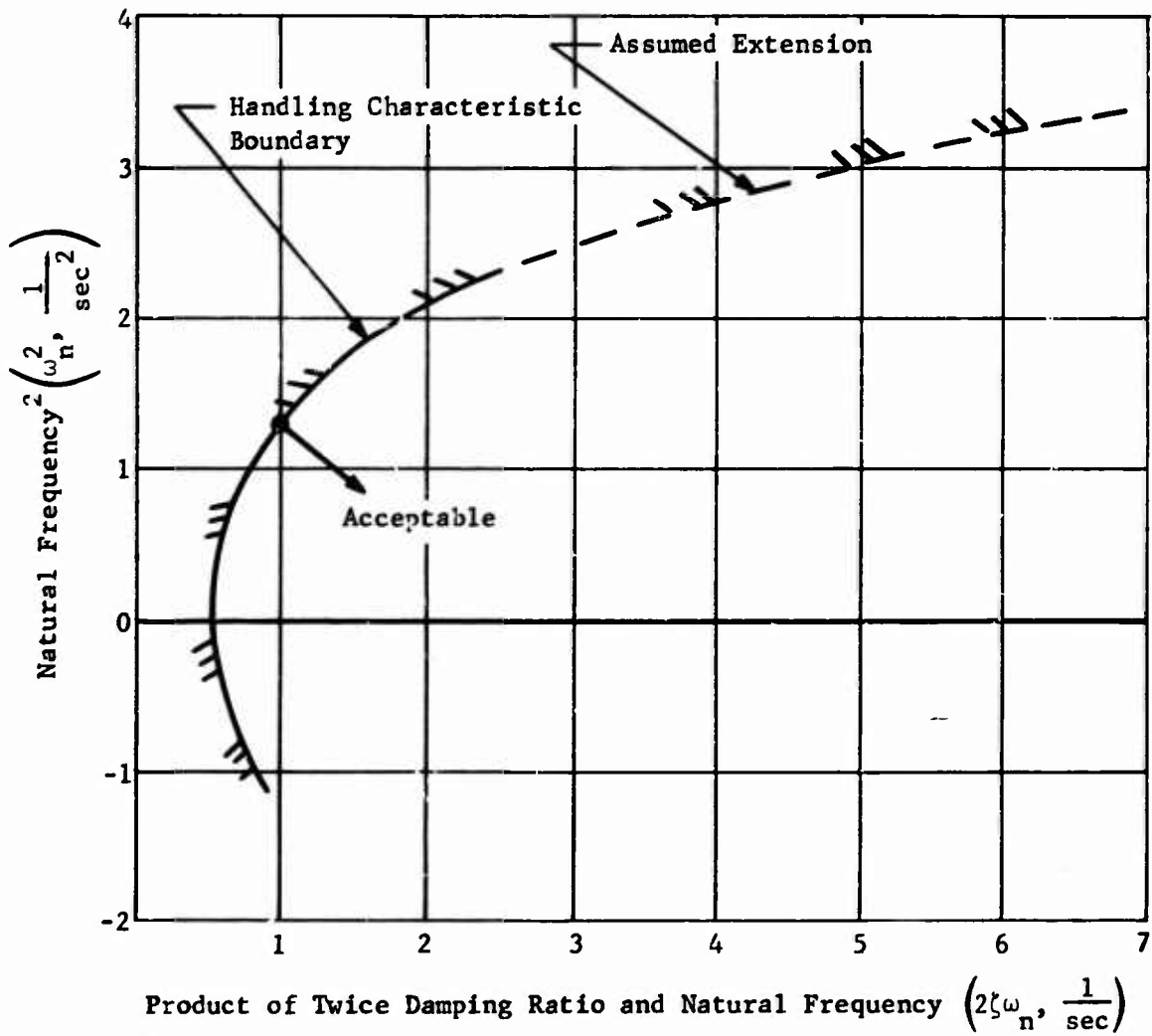

Fig. 5 Stage II Pitch and Yaw Handling Characteristic Requirements

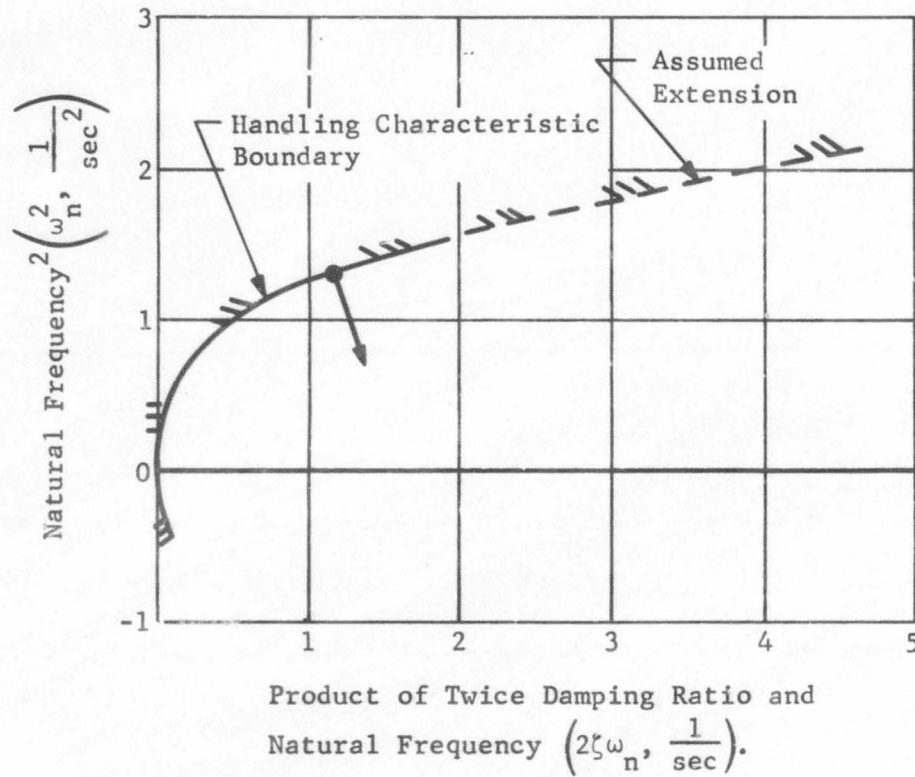

Fig. 6 Stage III Pitch and Yaw Handling Characteristic Requirements

Table 3 Roll Axis Handling Characteristic Requirements

Configuration	Control System Requirements	
Stage 0	$3 \leq \frac{K_R Tr}{I_{xx}} \leq 10$	$K_D \geq 0$
Stage I	$7.5 \leq \frac{K_R Tr}{I_{xx}} \leq 25$	$K_D \geq 0$
Stage II	$1 \leq \frac{K_R Tr}{I_{xx}} \leq 3$	$K_D \geq 0$
Stage III	$2.5 \leq \frac{K_R Tr}{I_{xx}} \leq 25$	$K_D \geq 0$

Note: K_R = Rate channel gain (sec).
 K_D = Displacement channel gain (dimensionless).
 T = Thrust available for rolling moment (lb).
 r = Distance from line of action of roll thrust to vehicle centerline (in.).
 I_{xx} = Vehicle moment of inertia about roll axis (in.-lb-sec²).

The Stage 0 pitch and yaw requirements are portrayed at the time of flight when aerodynamic loads are greatest (60 sec after liftoff), and thus represent the most stringent handling characteristics required during Stage 0 flight.

Since aerodynamic loads remain very nearly zero throughout Stage I, Stage II, and Stage III operation, handling characteristic requirements remain constant throughout each of these flight phases.

b. Stability Margin Requirements

The stability requirements on the PIBOL flight control system are identical to those imposed on the standard Titan III flight control system, except that the criteria are applicable only in the range of frequencies that include the effect of structural bending. The handling characteristic requirements replace the standard Titan III rigid-body requirements.

The stability requirements are expressed in terms of minimum acceptable gain and phase margins on the open-loop frequency response of the flight control system. Gain margin is defined as the amount of amplitude change in the system response that can occur before the system becomes unstable (if no change in the phase relationships occur). Phase margin is defined as the amount of phase change the system can accept without becoming unstable (if no amplitude changes occur). These margin requirements are applied to allow for variation in the vehicle parameters. In other words, the stability margins are analogous to the structural designer's margin of safety. Thus, the stability margin requirements become more stringent at the higher frequencies because the system parameters (such as bending characteristics) are less predictable there.

The PIBOL stability margin requirements are shown in Table 4, and are applicable to the pitch, yaw, and roll axes.

Table 4 PIBOL Stability Margin Requirements

Frequency Range	Minimum Gain Margin	Minimum Phase Margin
Below First Structural Mode Peak (Excluding Rigid-Body Region)	6 db	30 deg
Between First Structural Mode Peak and Third Structural Mode Peak	10 db	60 deg
Third Structural Mode and Above	10 db*	
*Independent of phase contribution.		

2. Method of Analysis

a. Assumptions

The majority of the assumptions that were a part of this analysis were directed by the contract statement of work (Ref 2). These assumptions were:

- 1) The response of the Titan III vehicle to a rate command from the pilot can be approximated by a second order equation, i.e., Eq [1];

- 2) The pilot makes no contribution to rigid-body performance, i.e., handling characteristics;
- 3) The pilot does not respond in any way to structural bending;
- 4) The pilot is capable of maintaining structural loads within acceptable limits through the proper use of the displays he has at his disposal (applicable to the Basic system only);
- 5) The transients occurring at the various stage separations and the transients occurring due to sequencing of the flight control system are within acceptable limits for the pilot.

Assumptions "1" (the second order approximation) and "2" (the pilot's contribution to handling characteristics) were necessary to correlate this study with the results of the previous Boeing study. Assumptions 3), 4), and 5) are results of, or extrapolation from, the Boeing study.

Assumptions independent of the statement of work were:

- 6) The handling characteristic requirements were extrapolated beyond the specification limits where the results of this study were not clearly within the requirements;
- 7) Optimization of the standard flight control system was not required for phases of flight where the standard Titan III/X-20A flight control system configuration was not finalized before the X-20A contract cancellation.

Assumption 6), handling characteristic requirement extrapolation, was used because, in some cases, the handling characteristics obtained from the Titan III system were in areas of the $\omega_n^2 - 2\zeta\omega_n$ plane where the requirements had not been clearly defined by the Boeing study. The assumed extensions are shown in Fig. 1 thru 6, and are believed to portray the most likely extension of these curves.

The cancellation of the X-20A program (midway through the PIBOL study) resulted in the need for Assumption 7. The baseline for the PIBOL study was to be the flight control system defined for the X-20A mission, but the flight control system for this mission was never optimized. However, the configuration of the flight control system was representative of an acceptable vehicle, and optimization would add little to the PIBOL study. The conclusions of this study are not affected by this assumption.

c. Handling Characteristic Evaluation Methods

The evaluation of the handling characteristics was accomplished by one of three different methods, depending on the manner in which the requirements were specified. For the Stage 0 pitch and yaw axes, the coefficients for the second order approximation (Eq [1]) were determined by comparing the transient response characteristics of the Stage 0 system with those of a second order system. For Stages I, II, and III pitch and yaw axes, the second order approximation was made by an empirical method described in Ref 1 and in App B, which relates the equivalent natural frequency and damping ratio of the system to the flight control system and vehicle parameters. For the roll axis (all stages) the flight control system gains were compared with the roll channel gain requirements specified in Table 3.

Block diagrams of the PIBOL configurations used to calculate the transient response of the Stage 0 pitch and yaw channels are shown in Fig. 7, 8, and 9. These block diagrams were developed from the simplified block diagrams in the contract statement of work.

The system transfer functions, $\dot{\theta}(S)/\delta_c(S)$ (Basic systems) and $\ddot{z}_{606}(S)/\delta_c(S)$ (Broader system), and the transient responses (for a unit step input at δ_c), $\dot{\theta}(t)$ and $\ddot{z}_{606}(t)$, were calculated with existing Martin 7094 programs.

The transient responses resulting from application of the unit step input at δ_c (the pilot's command) were then evaluated to determine the second order approximation. The second order approximation to the transient response was made by the method given in the contract statement of work and in App B. This method matches the overshoot and rise time, or oscillations, of any transient response to those of the second order system described by Eq [1]. This method allows the removal of the normal force terms in the closed-loop transfer function where the effect of these terms obscures the response of the system.

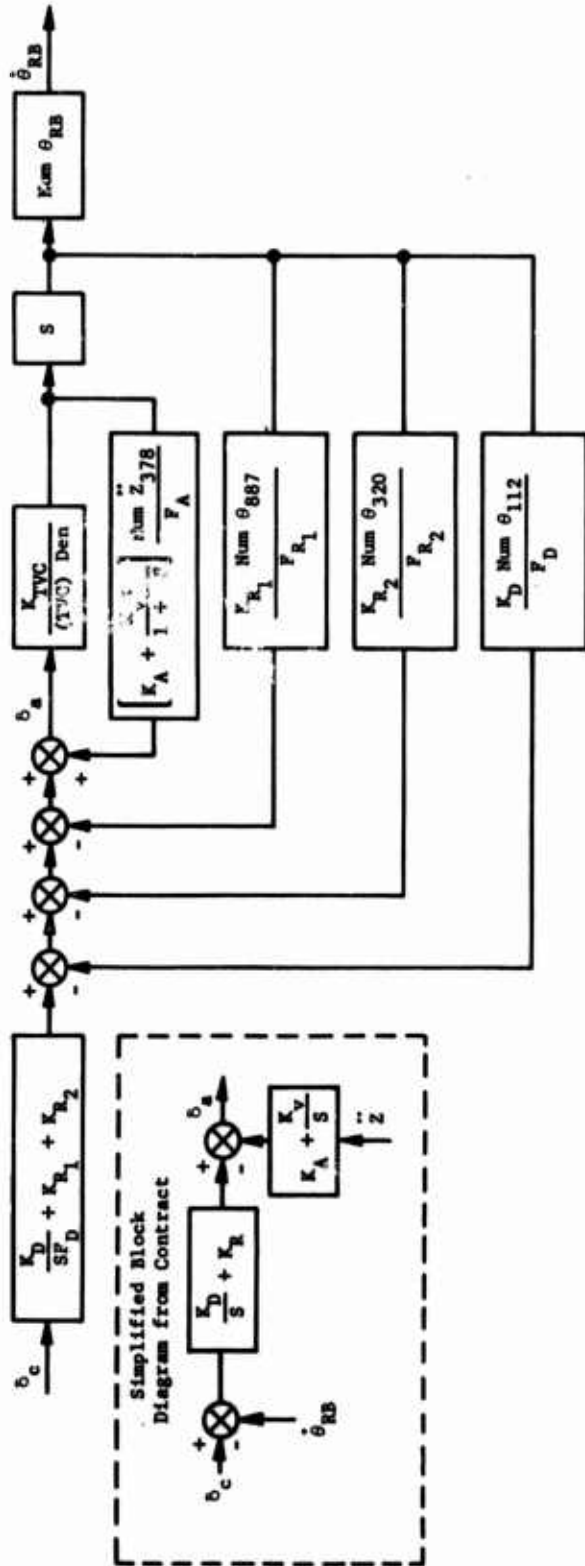

Legend:

K_D	Displ Channel Gain	Accel Gain
F_D	Displ Channel Filter	Velocity Gain
K_{R1}	Stage I Rate Channel Gain	τ Integrator Time Constant
F_{R1}	Stage I Rate Channel Filter	F_A Accelerometer Channel Filter
K_{R2}	Stage II Rate Channel Gain	Num \dot{Z} 378 Airframe Numerator for Acceleration at Sta 378
F_{R2}	Stage II Rate Channel Filter	Num θ 887 Airframe Numerator for Angular Displ at Sta 887
S	Laplace Operator	Num θ 320 Airframe Numerator for Angular Displ at Sta 320
K_{TVC}	Equiv TVC Gain	Num θ 112 Airframe Numerator for Angular Displ at Sta 112
(TVC)	TVC Dynamics	Num θ_{RB} Airframe Numerator for Rigid Body Angular Displ
Den	Denom of Airframe Transfer Function	θ_{RB} Rigid Body Angular Rate
δ_c	Pilot Command	
δ_a	Equiv TVC Defl	

Fig. 7 Stage 0 Block Diagram - Basic PIBOL, Rate + Displacement + Acceleration + Velocity Flight Control System (Pitch Axis Shown)

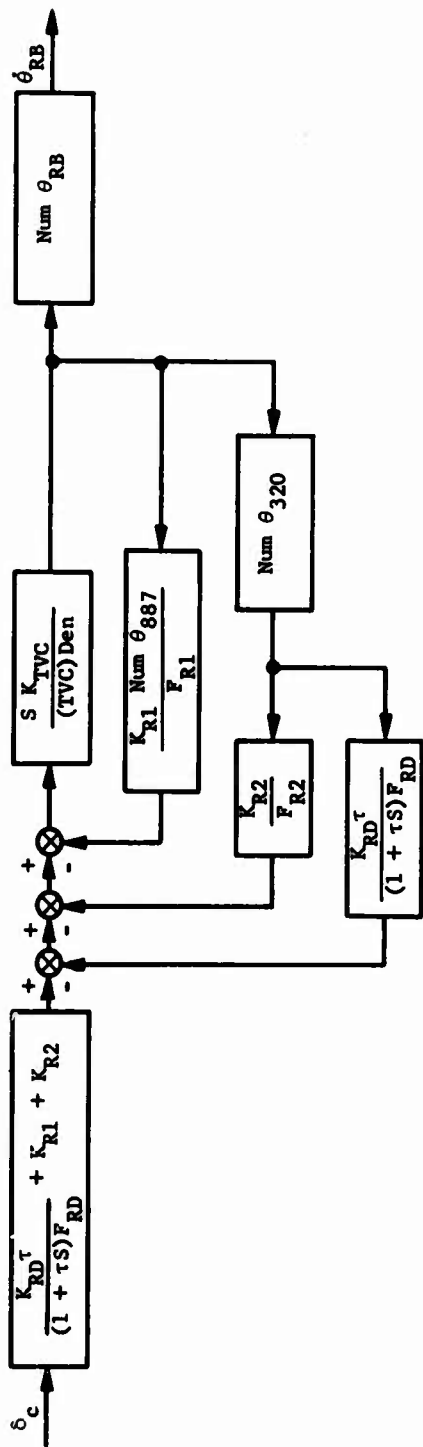

Legend:

Symbol	Description	Symbol	Description
K_D	Displ Channel Gain	K_V	Velocity Gain
K_D	Displ Channel Filter	τ	Integrator Time Constant
K_{R1}	Stage I Rate Channel Gain	F_A	Accelerometer Channel Filter
F_{R1}	Stage I Rate Channel Filter	Num 0 378	Airframe Numerator for Acceleration at Sta 378
K_{R2}	Stage II Rate Channel Gain	Num 0 887	Airframe Numerator for Angular Displ at Sta 887
F_{R2}	Stage II Rate Channel Filter	Num 0 320	Airframe Numerator for Angular Displ at Sta 320
S	Laplace Operator	Num 0 112	Airframe Numerator for Rigid Body Angular Displ at Sta 112
K_{TVC}	Equiv TVC Gain	Num 0 _{RB}	Airframe Numerator for Rigid Body Angular Displ
(TVC)	TVC Dynamics	$\dot{\theta}_{RB}$	Rigid Body Angular Rate
Den	Denom of Airframe Transfer Function	K_{RD}	Equivalent Displacement Channel Gain
δ_c	Pilot Command	F_{RD}	Equivalent Displacement Channel Filter
δ_a	Equiv TVC Defl		
K_A	Accel Gain		

Fig. 8 Stage 0 Block Diagram - Basic PIBOL, Rate + Approximate Integral of Rate Flight Control System (Pitch Axis Shown)

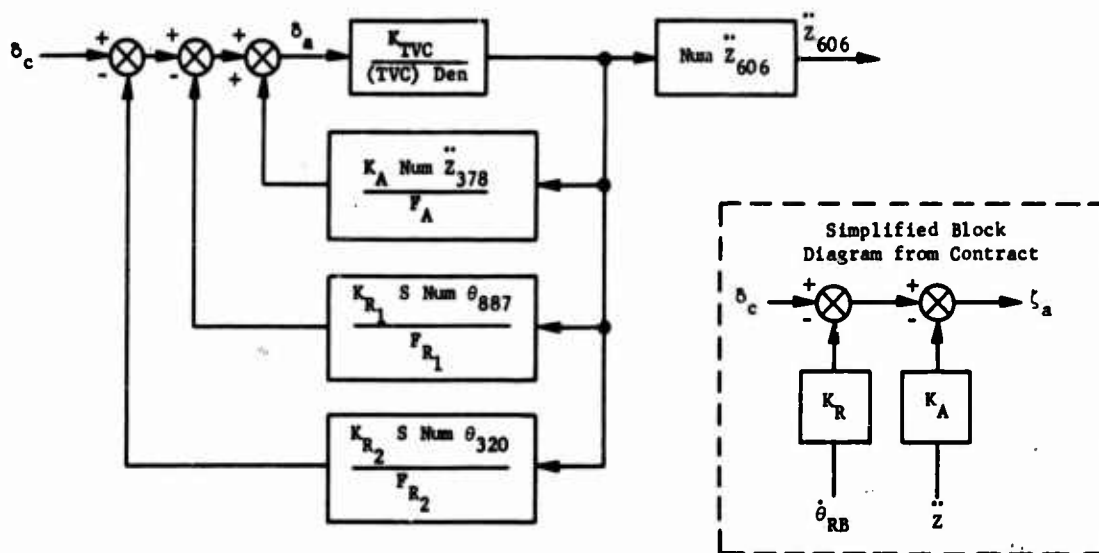
**Legend:**

K_D	Displ Channel Gain	K_V	Velocity Gain
F_D	Displ Channel Filter	τ	Integrator Time Constant
K_{R_1}	Stage I Rate Channel Gain	F_A	Accelerometer Channel Filter
F_{R_1}	Stage I Rate Channel Filter	Num Z_{378}	Airframe Numerator for Acceleration at Sta 378
K_{R_2}	Stage II Rate Channel Gain	Num θ_{887}	Airframe Numerator for Angular Displ at Sta 887
F_{R_2}	Stage II Rate Channel Filter	Num θ_{320}	Airframe Numerator for Angular Displ at Sta 320
S	Laplace Operator	Num θ_{112}	Airframe Numerator for Angular Displ at Sta 112
K_{TVC}	Equiv TVC Gain	Num θ_{RB}	Airframe Numerator for Rigid Body Angular Displ
(TVC)	TVC Dynamics	$\dot{\theta}_{RB}$	Rigid Body Angular Rate
Den	Denom of Airframe Transfer Function	Num Z_{606}	Airframe Numerator for Acceleration at Sta 606
δ_c	Pilot Command	Z_{606}	Acceleration at Sta 606
δ_a	Equiv TVC Defl		
K_A	Accel Gain		

Fig. 9 Stage 0, Broader FIBOL Block Diagram, Rate + Acceleration Flight Control System (Pitch Axis Shown)

The handling characteristics for the Stage I, Stage II, and Stage III pitch and yaw systems were calculated from the Boeing equations for the handling quality parameters, ω_n^2 and $2\zeta\omega_n$. These equations are presented in Section 12 of D2-80762 (Ref 1) and in App B.

For Stage I, Stage II, and Stage III operation, where the vehicle velocity is high and the aerodynamic terms small, the Boeing equations can be accurately approximated by:

$$\omega_n^2 = K_D \frac{T L g}{I_{yy}}, \quad [2]$$

$$2\zeta\omega_n = K_R \frac{T L g}{I_{yy}}, \quad [3]$$

where

ω_n = the system natural frequency,

ζ = the system damping ratio,

I_{yy} = moment of inertia about the pitch axis,

T = total thrust,

Lg = distance from engine gimbal to center of gravity,

K_D = flight control system displacement channel gain,

K_R = flight control system rate channel gain.

As discussed in Chap. III.A.1, the roll axis handling characteristic requirements were specified only in terms of constraints on the roll channel gains combined with vehicle roll thrust, inertia, and moment arm. Thus, the handling characteristic analyses in the roll axis, for all stages, consisted of comparison of the flight control system channel gains with the PIBOL requirements.

d. Stability Analysis Methods

The mathematical model used for the PIBOL stability analyses was identical to the model used for the initial Titan III/X-20A stability investigations. This model used a linearized mathematical description of the Titan III vehicle (with the X-20A payload), which included the effects of structural bending and concentrated aerodynamics. Dynamic characteristics of sensors and thrust vector control devices included were as described in Appendix I.

The stability of the PIBOL systems was evaluated in the conventional manner. The open-loop frequency response of the vehicle, including flight control system, was evaluated to assure that the required stability margins were attained. This approach required knowledge of the airframe transfer functions that describe the response of the airframe to stimuli from the control system, i.e., control moments. The majority of these airframe transfer functions had previously been obtained in earlier Titan III/X-20A stability analyses.

3. Summary

Various systems for providing piloted control of the Titan III booster were analyzed. These system configurations are summarized in Table 5. Table 5 also designates the system recommended for the application of piloted control of Titan III.

Tolerance effects were evaluated on the recommended system and the Stage 0 system with only rate and acceleration feedback. The analysis results can be summarized as follows:

- 1) The Basic Stage 0 pitch-yaw system (where the flight control system provides the attitude reference) can be designed to meet the PIBOL requirements either by using a displacement gyro or an approximate integral of rate to obtain the displacement signal; however, the approximate integral system allows the greatest hardware simplification; either system requires removal of the accelerometer feedback normally used in Titan III;
- 2) The Broader Stage 0 pitch-yaw PIBOL concept (where the pilot provides the attitude reference) was not adequately stabilized. Furthermore, tolerance effects on this system were entirely unacceptable;

- 3) The upper stages (Stages I, II, and III) can meet the PIBOL requirements in pitch and yaw under a variety of circumstances, most significantly with the displacement channel gain at zero (thus, not needing a displacement gyro);
- 4) PIBOL roll axis requirements can be met (with or without a displacement channel gain) for all phases of flight.

The following tabulation summarizes the recommended PIBOL system configuration:

<u>Phase of Operation</u>	<u>Control System Configuration</u>
Stage 0, Pitch and Yaw	Rate + approximate integral of rate
Stage 0, Roll	Rate only
Stage I, Pitch, Yaw, and Roll	Rate only
Stage II, Pitch, Yaw, and Roll	Rate only
Stage III, Pitch and Yaw	Open loop, i.e., no rate, no displacement
Stage III, Roll	Rate only

4. Results

a. Basic PIBOL Results.

Stage 0 Pitch and Yaw Channels - For Stage 0, the first Basic PIBOL system examined was a system that used attitude error signals obtained from an attitude gyro near the location of the booster inertial guidance system (Fig. 7). This approach appeared attractive, because if the handling requirements were obtained with channel gains and dynamics identical to those used in the standard Titan III/X-20A flight control system, the stability margin requirements would be attained automatically.

Table 5 PIBOL Configurations Analyzed

Flight Control System Configuration				
Phase of Flight	Recommended System	Displacement Channel	Rate Channels	Acceleration Channel
Stage 0, Pitch and Yaw Axes	X	Displacement Gyros	Same as std Titan III	None
		Displacement Gyros	Same as std Titan III	Same as std Titan III
		Approximate Integral of Rate	Same as std Titan III	None
Stage I, Pitch and Yaw Axes	X	Displacement Gyros	Same as std Titan III	None
		Displacement Gyro (Reduced channel gain)	Same as std Titan III	None
Stage II, Pitch and Yaw Axes	X	None	Same as std Titan III	None
		Displacement Gyros	Same as std Titan III	None
		Displacement Gyros (Reduced channel gain)	Same as std Titan III	None
Stage III, Pitch and Yaw Axes	X	None	Same as std Titan III	None
		Displacement Gyros	Same as std Titan III	None
Stage 0, Pitch and Yaw Axes		None	Gains increased over std Titan III	Same as std Titan III, except no approximate integration
Stage 0, Roll Axis	X	None	Gains increased over std Titan III	None
Stage I and Stage II, Roll Axis	X	None	Same as std Titan III	None
Stage III, Roll Axis	X	None	Changed from std Titan III	None

Note: See Chap. III.A.4 for description.

Transient solutions were obtained for this system in two configurations. First, the system was analyzed with only angular displacement and angular rate feedback, using the displacement and rate channel gains, and dynamics, of the standard Titan III/X-20A flight control system. The handling characteristics obtained for this system are shown in Fig. 10 (pitch) and Fig. 11 (yaw), and are well within acceptable limits. Similarly, the stability margins obtained were within acceptable limits. Typical transient solutions are shown in App C.

Transient solutions were also obtained for this system (displacement gyro; block diagram, Fig. 7), using angular displacement, angular rate, and lateral acceleration feedback paths, again with the gains and dynamics of the standard Titan III/X-20A flight control system. As shown on Fig. 12 (pitch) and Fig. 13 (yaw), the handling characteristics obtained for this system did not meet the handling characteristic requirements. The transient solutions from which these handling characteristics were obtained are shown in App C. Since the option existed to operate the Basic PIBOL system without lateral acceleration feedback (Chap. III. A.2), no further attempts were made to improve the handling characteristics of this system. The system previously discussed (angular displacement and angular rate feedback only) provided satisfactory stability and handling characteristics with less effect on the existing flight control system mechanization.

A second form of Stage 0 Basic PIBOL was previously shown in Fig. 8. This system is identical to the previous Basic PIBOL system, except that the angular displacement feedback is obtained by performing an approximate integration on the existing Stage II angular rate signal ($\dot{\theta}_{320}$). The angular rate feedback paths (K_{R1} , K_{R2}) remained unchanged.

The handling characteristics obtained for this system, using a time constant of 7.5 sec in the approximate integrator, are shown in Fig. 14, (pitch) and Fig. 15 (yaw). Time constants greater than 5 sec gave similar results. Transient solutions from which these handling characteristics were computed are shown in App C. Stability margins for this system are also acceptable as shown in the open-loop frequency response plots in App C. Since the system using the approximate integral of rate allows greater hardware simplification and meets the PIBOL requirements; it is the preferred system.

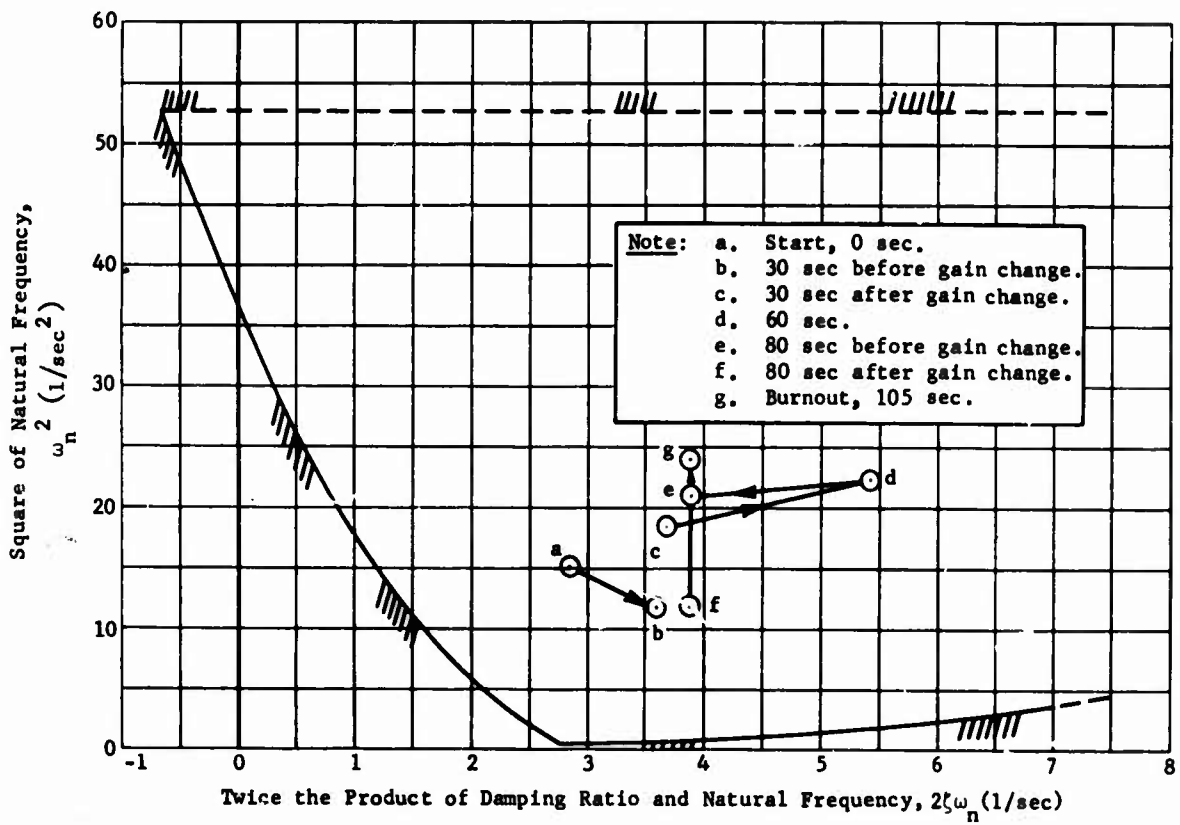

Channel	Gains			Dynamics All Times
	0 to 30 sec	30 to 80 sec	80 to 80	
Displacement	$K_D = 1.11$	$K_D = 1.40$	$K_D = 1.0$	$\left(\frac{1}{1 + S/15}\right)$
Stage I Rate	$K_{R_1} = 0.46$	$K_{R_1} = 0.52$	$K_{R_1} = 0.34$	$\frac{1}{(1 + S/40)^2}$
Stage II Rate	$K_{R_2} = 0.17$	$K_{R_2} = 0.18$	$K_{R_2} = 0.195$	$\frac{1}{(1 + S/30)^2}$

Fig. 10 Handling Characteristics Stage 0, Pitch, Basic System Without Load Relief

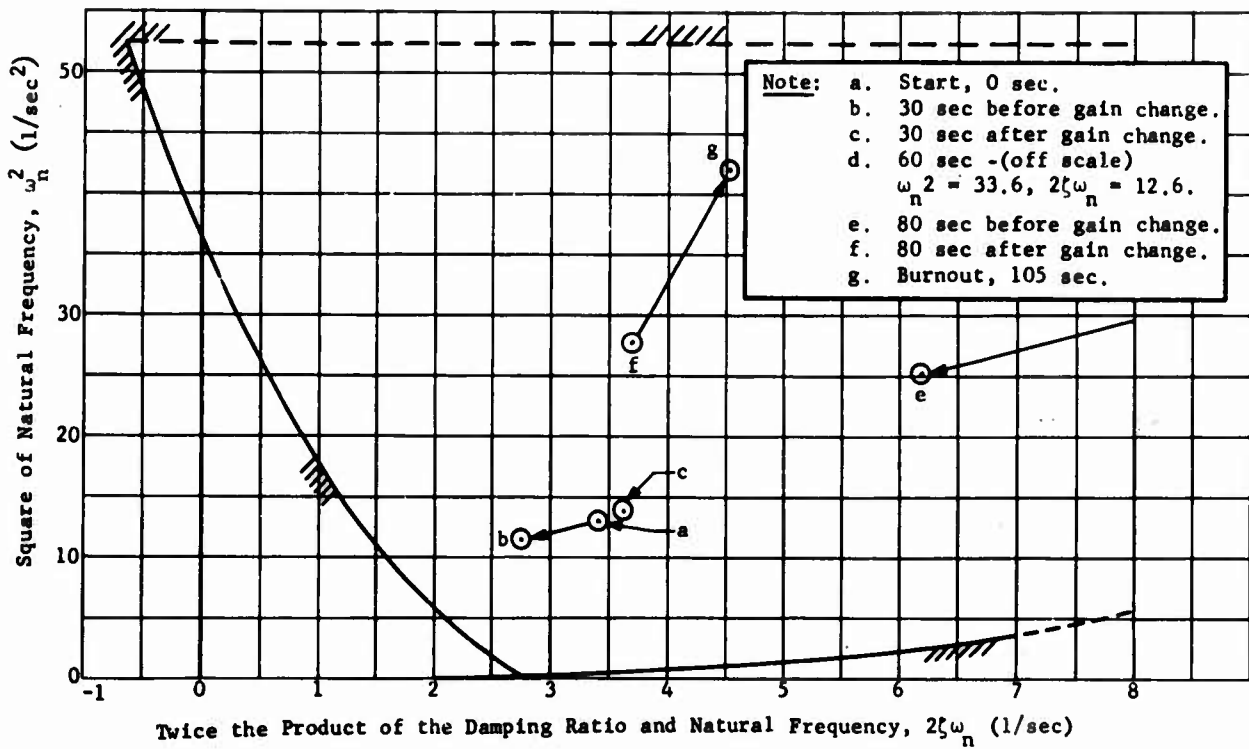

Channel	Gains			Dynamics All Times
	0 to 30 sec	30 to 80 sec	80 to 80	
Displacement	$K_D = 0.80$	$K_D = 0.65$	$K_D = 1.0$	$\frac{1}{(1 + S/15)^2}$
Stage I Rate	$K_{R_1} = 0.30$	$K_{R_1} = 0.38$	$K_{R_1} = 0.48$	$\frac{1}{(1 + S/15)^2}$
Stage II Rate	$K_{R_2} = 0.25$	$K_{R_2} = 0.25$	$K_{R_2} = 0.32$	$\frac{1}{(1 + S/15)^2}$

Fig. 11 Handling Characteristics Stage 0, Yaw, Basic System Without Load Relief

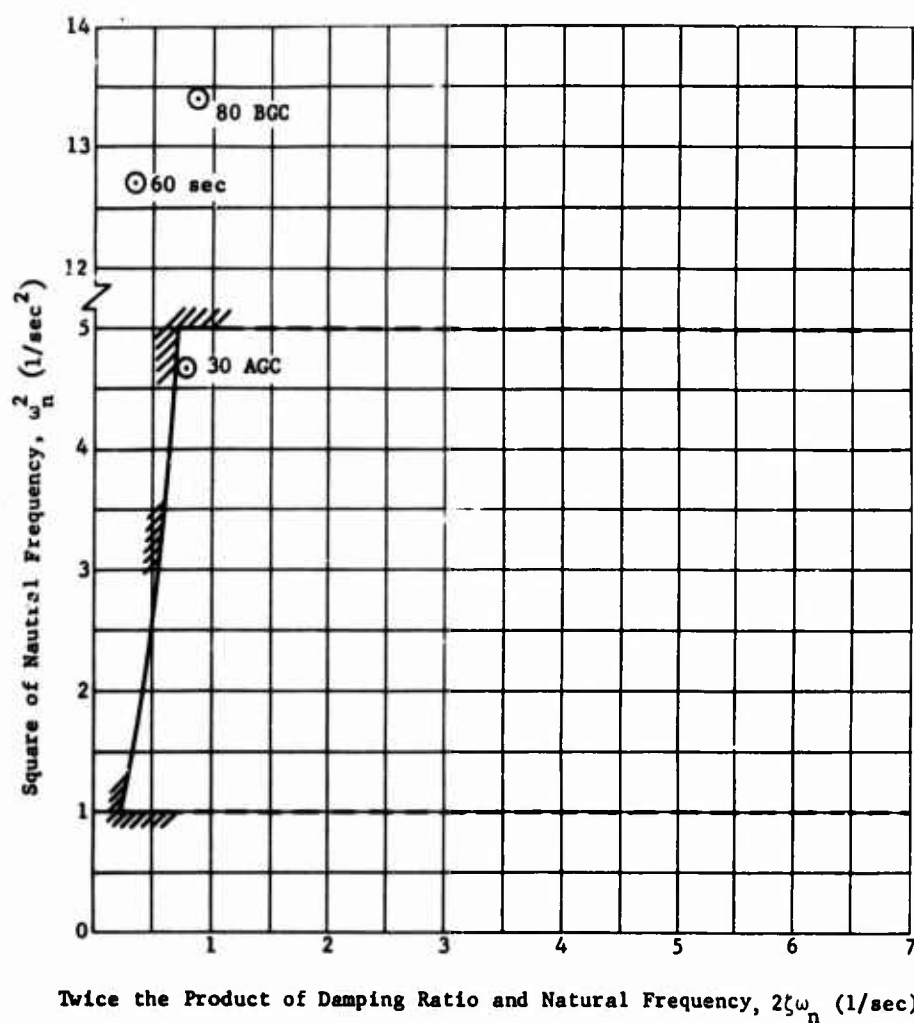

Channel	Gains	Dynamics
	30 to 80 sec	
Displacement,	$K_D = 1.40$	$\frac{1}{(1 + s/15)}$
Stage I Rate	$K_{R_1} = 0.52$	$\frac{1}{(1 + s/40)^2}$
Stage II Rate	$K_{R_2} = 0.18$	$\frac{1}{(1 + s/30)^2}$
Acceleration	$K_A = 0.75E-3$	$\frac{1}{(1 + s/3)(1 + s/5)(1 + s/10)}$
Velocity	$K_V = 0.30E-3$	$\frac{1}{(1 + 7.5s)(1 + s/3)(1 + s/5)(1 + s/10)}$

Fig. 12 Handling Characteristics Stage 0, Pitch, Basic System with Load Relief

SSD-CR-64-32

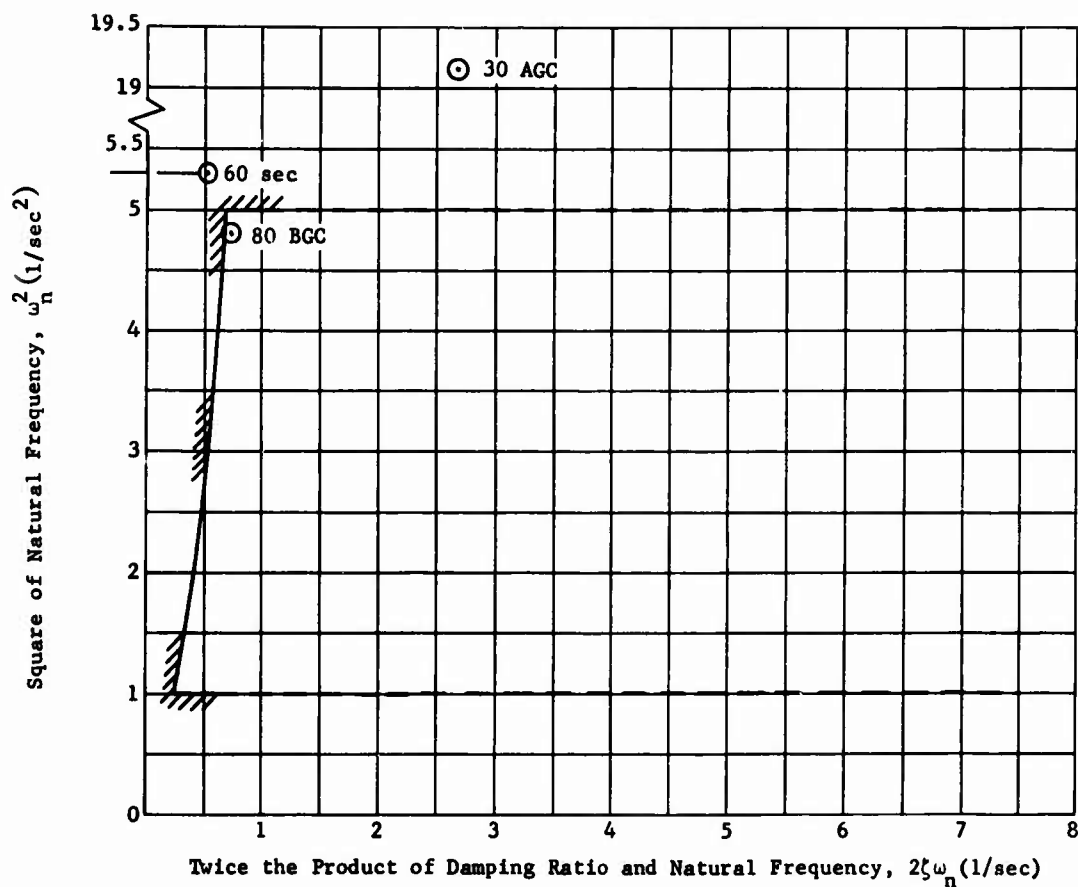

Channels	Gains	Dynamics
	30 to 80 sec	
Displacement	$K_D = 0.65$	$\frac{1}{(1 + s/15)^2}$
Stage I Rate	$K_{R_1} = 0.28$	$\frac{1}{(1 + s/15)^2}$
Stage II Rate	$K_{R_2} = 0.25$	$\frac{1}{(1 + s/15)^2}$
Acceleration	$K_A = 1.0E-3$	$\frac{1}{(1 + s/3)(1 + s/10)^2}$
Velocity	$K_V = 0.28E-3$	$\frac{1}{(1 + 7.5s)(1 + s/3)(1 + s/10)^2}$

Fig. 13 Handling Characteristics Stage 0, Yaw, Basic System with Load Relief

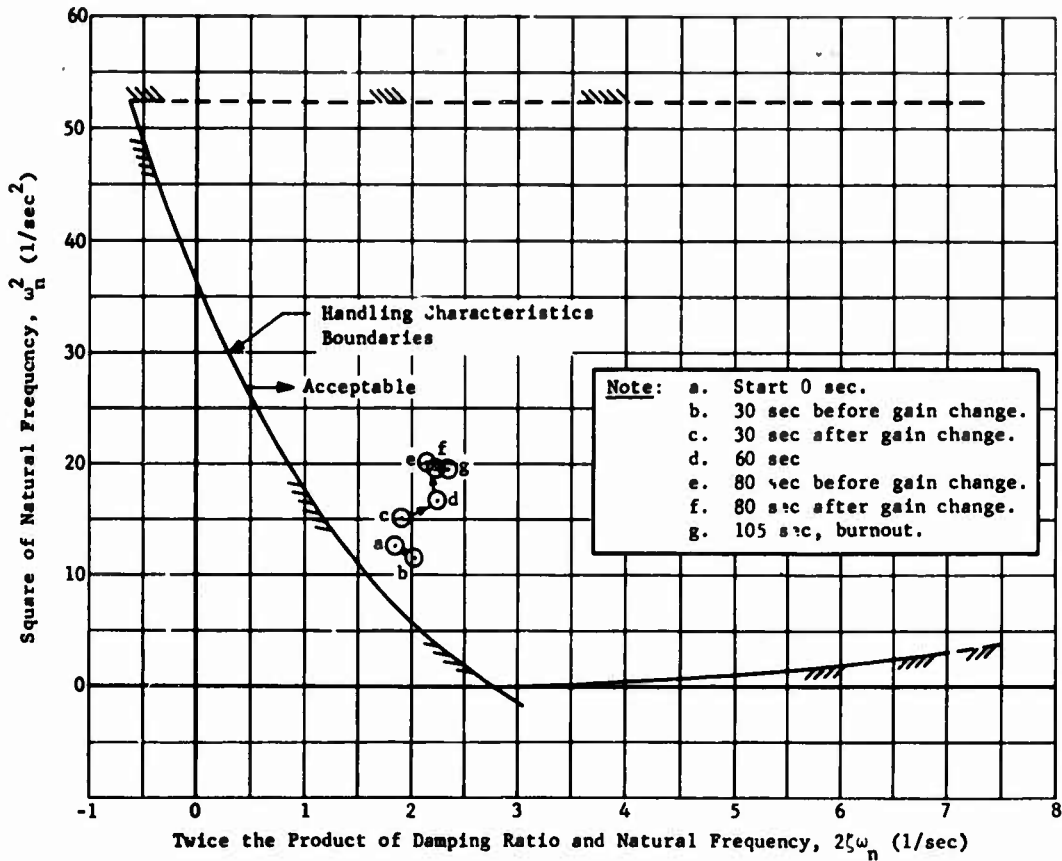

Channel	Gains			Dynamics All Times
	0 to 30 sec	30 to 80 sec	80 to 80	
Displacement	$K_D = 0$	$K_D = 0$	$K_D = 0$	Not Applicable
Approx. Displ	$K_{RD} = 1.72$	$K_{RD} = 2.08$	$K_{RD} = 1.54$	$\frac{K_{RD} (7.5)}{(1 + 7.5 S)(1 + \frac{S}{10})}$
Stage I Rate	$K_{R1} = 0.46$	$K_{R1} = 0.52$	$K_{R1} = 0.34$	$\frac{K_{R1}}{(1 + \frac{S}{40})^2}$
Stage II Rate	$K_{R2} = 0.17$	$K_{R2} = 0.18$	$K_{R2} = 0.195$	$\frac{K_{R2}}{(1 + \frac{S}{30})^2}$

Fig. 14 Basic System Handling Characteristics Stage 0, Pitch Axis, Rate + Approximate Integral of Rate Flight Control System

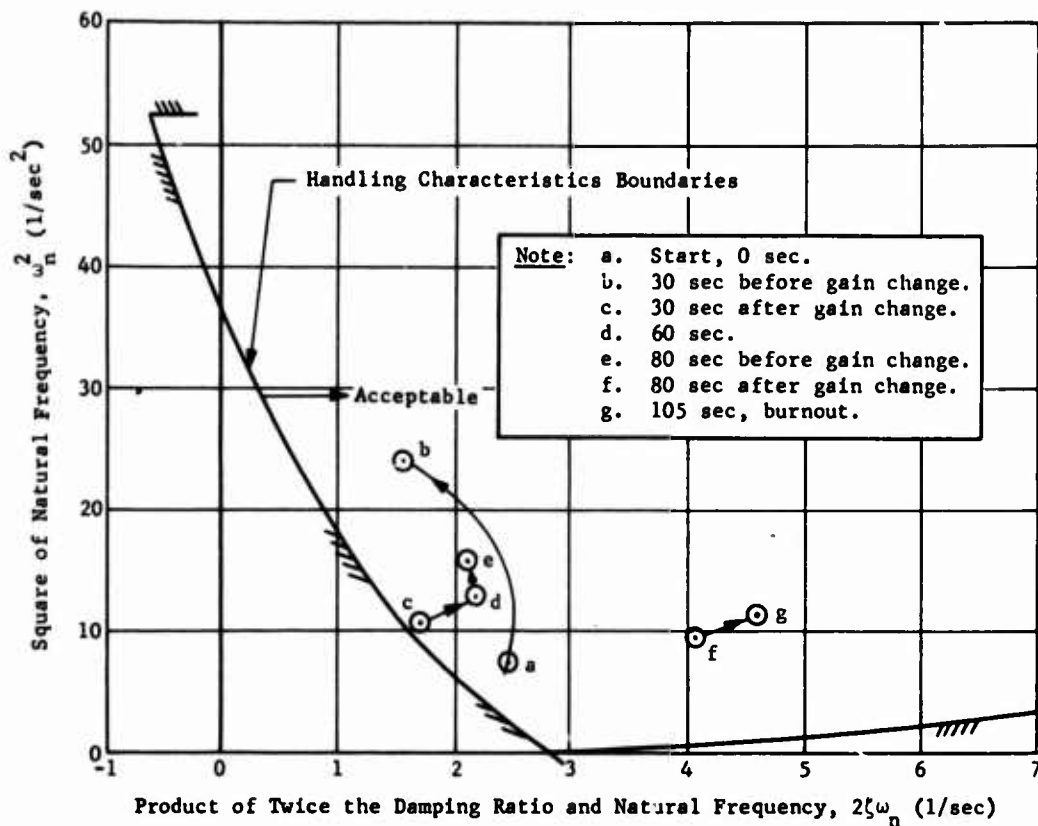

Channel	Gains			Dynamics All Times
	0 to 30 sec	30 to 80 sec	80 to BO	
Displacement	$K_D = 0$	$K_D = 0$	$K_D = 0$	Not Applicable
Approx. Displ	$K_{RD} = 1.68$	$K_{RD} = 1.46$	$K_{RD} = 2.43$	$\frac{K_{RD} (7.5)}{(1 + 7.5 S) \left(1 + \frac{S}{5}\right)}$
Stage I Rate	$K_{R1} = 0.30$	$K_{R1} = 0.38$	$K_{R1} = 0.48$	$\frac{K_{R1}}{\left(1 + \frac{S}{15}\right)^2}$
Stage II Rate	$K_{R2} = 0.25$	$K_{R2} = 0.25$	$K_{R2} = 0.32$	$\frac{K_{R2}}{\left(1 + \frac{S}{15}\right)^2}$

Fig. 15 Basic System Handling Characteristics, Stage 0 Yaw Axis, Rate + Approximate Integral of Rate Flight Control System

Stages I, II, and III Pitch and Yaw Channels - The approach taken for the Basic PIBOL investigation of Stage I, Stage II, and Stage III pitch and yaw operations used the displacement gyro (as in the Stage 0 basic study) and the gains and dynamics of the standard Titan III/X20A flight control system. Although the standard Titan III/X-20A flight control system for Stages I, II, and III was not finalized at the time of the X-20A cancellation, the changes that would have occurred in the final optimization would have little effect on the PIBOL system.

The handling characteristics obtained for the Stage I, Stage II, and Stage III pitch or yaw systems with the displacement gyro and the standard Titan III/X-20A flight control system gains and dynamics are shown in Fig. 16, 17, and 18. These handling characteristics were calculated by using Eq [2] and [3]. The Stage III results (Fig. 18) are acceptable, but the Stage I and Stage II results show that the system natural frequency is too high to stay within the handling characteristic requirements during the applicable flight phases. The stability margins of the Stage I, Stage II, and Stage III systems are not changed from those of the automatic system, and therefore, are acceptable.

To meet the handling characteristic requirements for Stage I, a reduction in displacement channel gain of approximately 50% is necessary (from the standard Titan III/X-20A gains). Handling characteristics for this system are also shown on Fig. 16, and are entirely within the requirements.

With a similar reduction in Stage II displacement channel gain, the Stage II handling characteristics are improved, but still lie outside the requirements for the last 11.5 sec of Stage II flight (Fig. 17).

Because the reduction in displacement channel gain can easily (in the hardware) be carried to the extreme value of $K_D = 0$ (K_D displacement channel gain), this method was also evaluated. With the displacement channel gain at zero, the handling characteristics of the Stage I and Stage II systems are further improved, as shown in Fig. 16 and 17.

The stability margins for the Stage I system with $K_D = 0$ are shown on the open-loop frequency response plots in App C. While the margins are changed from those of the standard Titan III system, they are still adequate.

Symbol	Gain Configuration	0 → Gain Change		Gain Change → Burnout	
		K_R	K_D	K_R	K_D
⊙	Std Titan III/X-20A Gains	0.78	0.8	0.58	0.60
⊠	1/2 Std Titan III/X-20A Displ Gain	0.78	0.4	0.58	0.30
△	Displ Gain at Zero	0.78	0	0.58	0

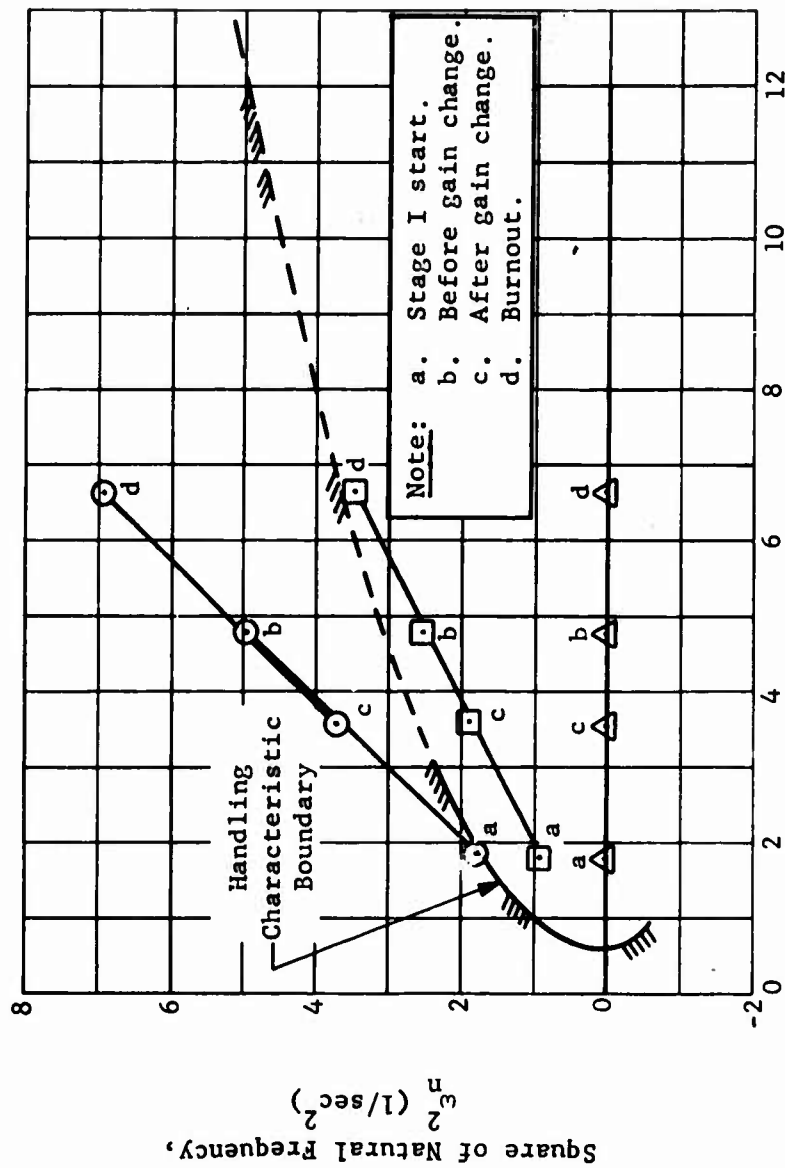

Twice the Product of Damping Ratio and Natural Frequency, $2\zeta\omega_n$, (l/sec)

Fig. 16 Pitch and Yaw Stage I Handling Characteristics

Gain Configuration	Symbol	Stage II Start to Burnout	
		K_R	K_D
Std Titan III/X-20A Gains	⊙	0.3	0.6
1/2 Std Titan/X-20A Displ Gains	⊠	0.3	0.3
Displ Gain at Zero	△	0.3	0

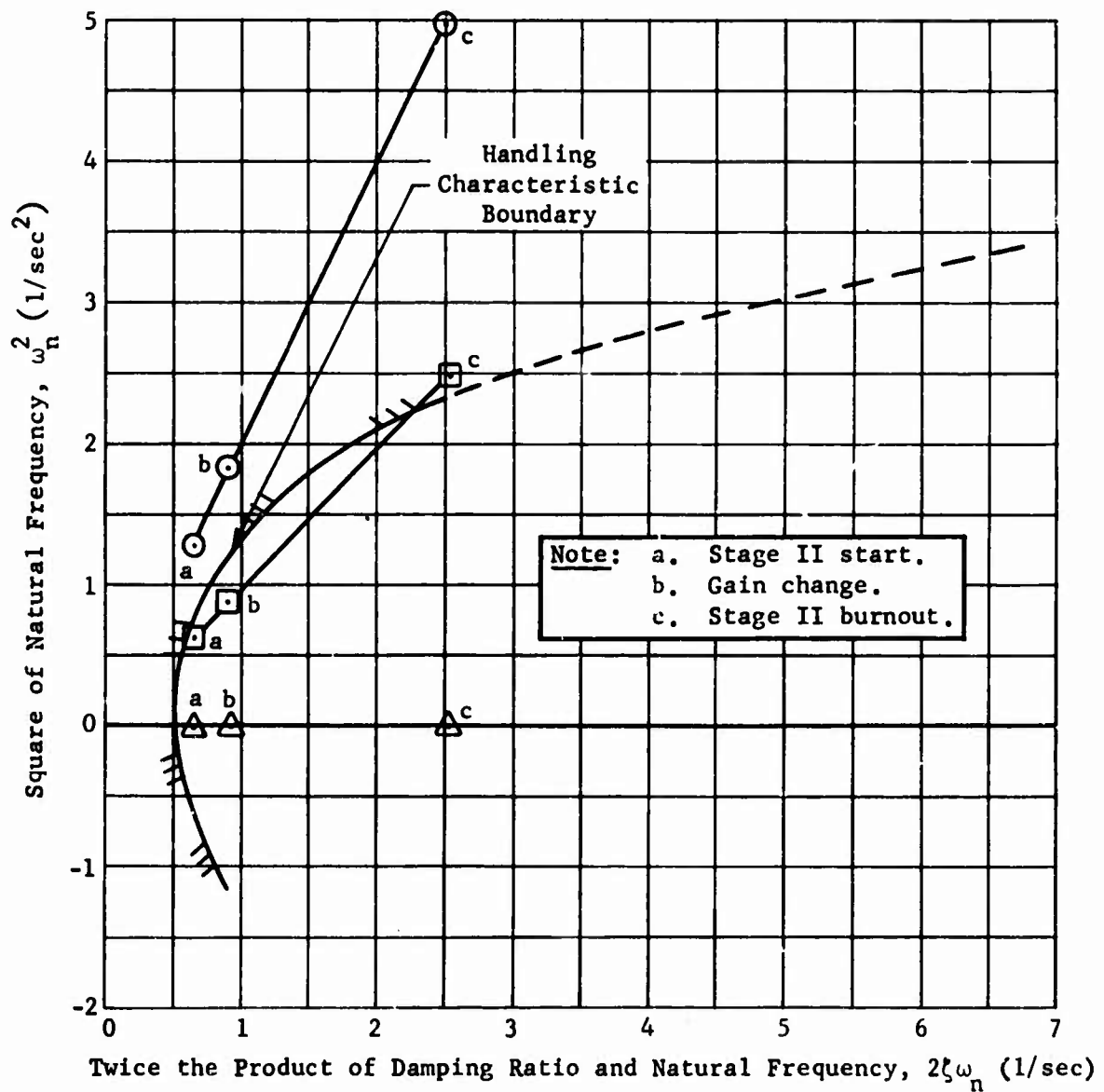

Fig. 17 Pitch and Yaw Stage II Handling Characteristics

Gain Configuration	Symbol	Stage III Start to Burnout	
		Equiv K_R	K_D
Std Titan III/X-20A Gains	⊙	0.6	0.6
Displ and Rate Gains Set at Zero	△	0	0

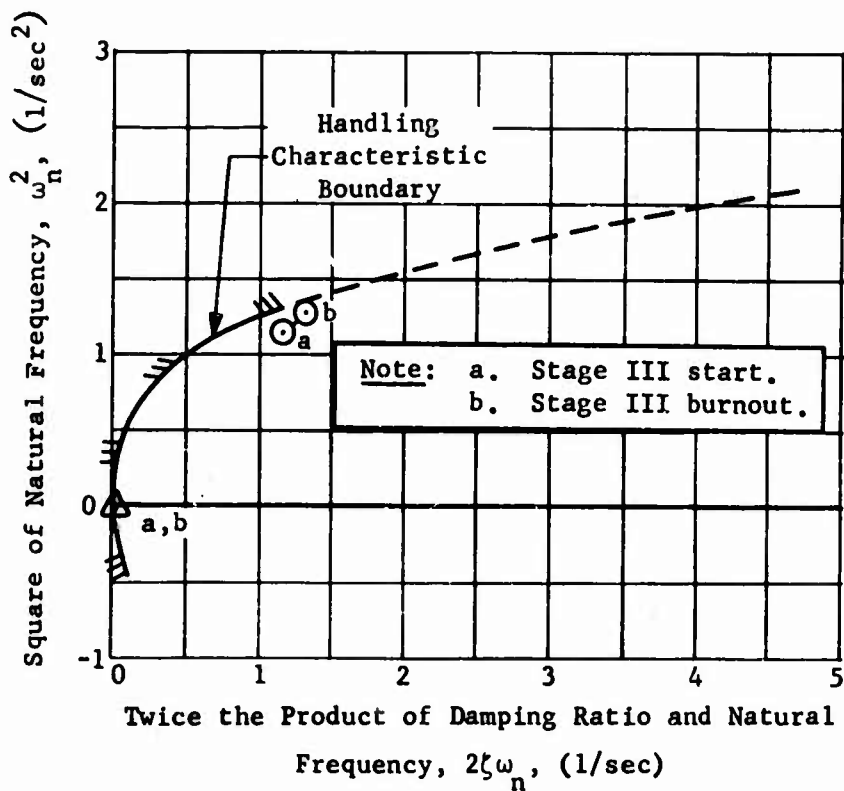

Fig. 18 Pitch and Yaw Stage III Handling Characteristics

The stability margins for the Stage II system with $K_D = 0$ are, for all practical purposes, identical to those of the standard Titan III/X-20A flight control system. Stability margins for the Stage II system are shown on the open-loop frequency response plots in App C. Although these margins are not optimized, they are identical to those for the standard Titan III/X-20A system, and are therefore acceptable.

The Stage I and Stage II systems with $K_D = 0$ are recommended for the PIBOL configuration.

In conjunction with the evaluation of $K_D = 0$ for Stage I and Stage II, the affect of reducing K_D to zero for Stage III operation was also investigated. Since the standard Titan III vehicle does not provide a rate gyro in Stage III, but derives rate signals by differentiating the angular displacement signal, the PIBOL hardware is simplest if both the displacement and rate channel gains can be set at zero. Figure 18 shows that the Stage III handling characteristics are marginal for this case. However, with the gains set at zero, no tolerance problems exist. Furthermore, structural bending stability problems are non-existent, since there are no control system signals present to reinforce or excite structural bending. Therefore this marginal system is recommended for the Titan III/X-20A system.

b. Broader PIBOL Results

Stage 0 Pitch and Yaw Channels - For the Stage 0 pitch and yaw channels, the Broader PIBOL concept was to use only angular rate and lateral acceleration feedback (Fig. 9). This meant that when transferring from the standard Titan III/X-20A flight configuration to the PIBOL configuration, the system had to be able to accept the removal of the angular attitude error signal and meet the stability and handling criteria. During Stage 0 operation, the vehicle is very flexible and the forces exciting the structural bending are large. This causes large bending deflections that are made acceptable in the standard Titan III flight control system by combining signals from the two rate gyros (angular rate signals), the lateral accelerometer, and the booster inertial guidance system (angular displacement signal) in a manner that reduces the amplitude of the structural bending peaks and obtains the required stability margins. This balance is upset in the Broader PIBOL concept when the angular displacement signal is removed.

When the displacement signal is removed from the control system, the total resultant vector that represents the system amplitude and phase response at the first bending mode frequency moves away from the phase-stable direction. This reduces the phase margin between the first and second structural modes. To move the resulting vector toward the phase-stable direction, it was necessary to remove one of the rate channel filters in the Stage I rate channel. Removal of a single filter was chosen because a completely unfiltered channel, i.e., with both filters removed, could lead to difficulties with structural bending at higher frequencies, even though it aided in stabilization of low frequency bending effects.

After adequate stability margins were attained, the handling characteristics were evaluated. Initial transient solutions conducted at 60 sec in the pitch axis showed that a significant increase in the rate channel gains and removal of the velocity feedback term (K_V) would be required before satisfactory handling characteristics could be obtained. Subsequent analysis showed that the total rate channel gain ($K_{R1} + K_{R2}$) would have to be increased from 0.7 (for the Standard Titan III/X-20A configuration) to 1.0 before anything other than marginal handling characteristics would result. The transient solution for this case is shown in App D. Handling characteristics obtained are shown in Fig. 19.

Typically, as the rate channel gains are increased, the structural bending mode stability becomes harder to attain. Typical stability margins for this system are shown in the open-loop frequency response plots in App D, and meet requirements in all areas except for the third structural mode and the phase margin on the low frequency side of the first structural mode at 30 sec. No method was found to improve the third structural mode margin. No further attempt was made at optimizing this system, pending results of the tolerance analysis, since the system was anticipated as being extremely tolerance sensitive.

Stages I, II, and III Pitch and Yaw Channels - Results for the Stage I, Stage II, and Stage III Broader PIBOL system were described in Chap. III.A.3. Broader PIBOL for these stages is the same as Basic PIBOL with the displacement channel gain set at zero.

Channel	Gain (30 to 60 sec)	Dynamics
Stage I Rate	$K_{R_1} = 0.64$	$\frac{K_{R_1}}{(1 + s/40)}$
Stage II Rate	$K_{R_2} = 0.36$	$\frac{K_{R_1}}{(1 + s/30)^2}$
Acceleration	$K_A = 0.75 \times 10^{-3}$	$\frac{K_A}{(1 + s/3)(1 + s/5)(1 + s/10)}$

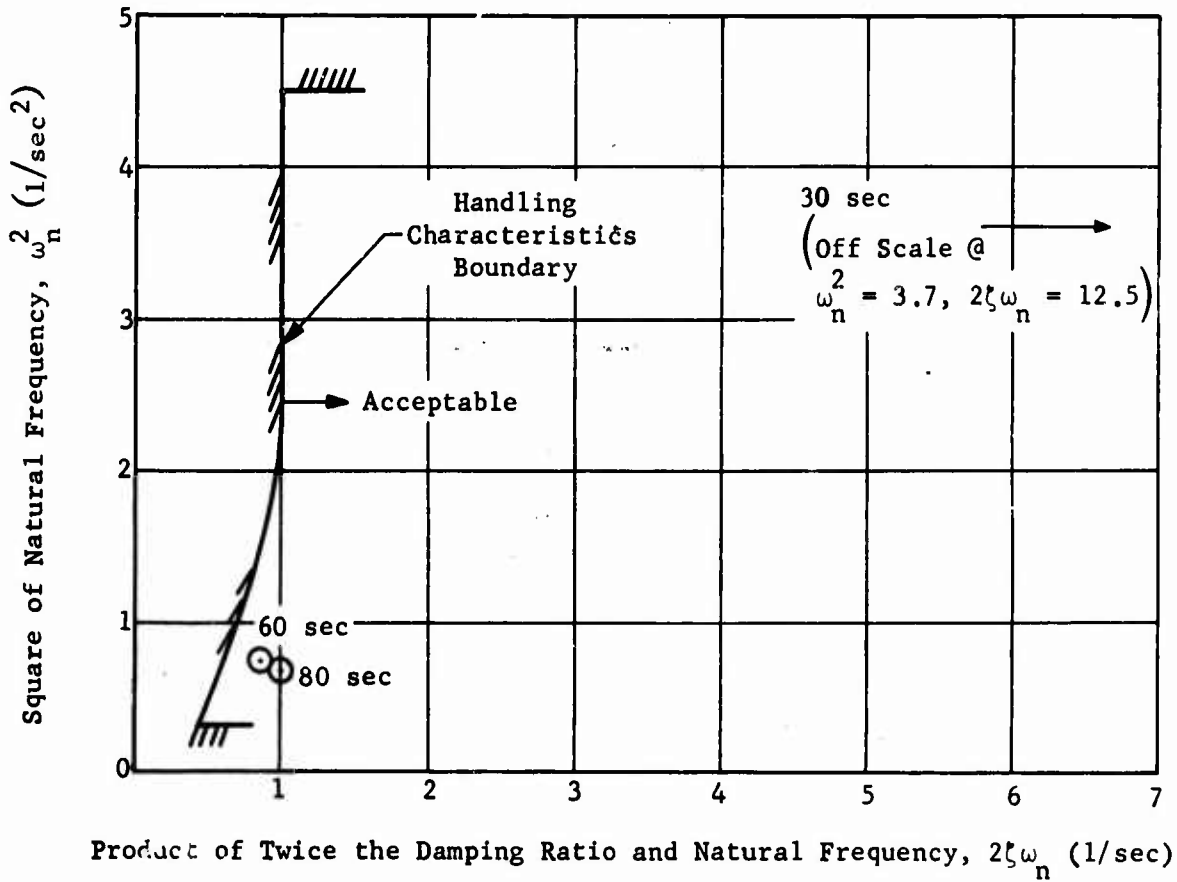

Fig. 19 Broader System Handling Characteristics Stage 0 Pitch Axis

c. Roll Channel Results

As discussed in Chap. III.A.2.b, the roll handling characteristic analysis consisted of comparing the standard Titan III/X-20A flight control system characteristics with the PIBOL requirements on flight control system channel gains.

For Stage I and Stage II operation, the standard Titan III/X-20A flight control system gains are compatible with the PIBOL handling characteristic requirements without modification. Table 4 shows both the flight control system channel gains and the required limits. The Stage I and Stage II PIBOL systems meet the stability margins with or without a roll displacement channel gain.

The Stage 0 roll system, as tentatively designed for the standard Titan III/X-20A configuration, does not meet the PIBOL handling characteristic requirements throughout flight. The roll rate channel gains are much lower than the gains required for PIBOL (Table 6). Further analysis of the Stage 0 system showed that the roll rate channel gains are limited by torsional bending considerations, and cannot be increased far enough (using the Titan III hardware) to meet the PIBOL requirements.

Mixing of the Stage I and Stage II roll rate gyros, use of a Stage III roll rate gyro, and additional rate sensor locations were investigated as ways of allowing an overall increase in rate channel gain. All possibilities were unsatisfactory, because they either did not provide adequate stability margins on the first torsional mode or caused an instability of the second torsional mode. The overall problem was a direct result of the large torsional deflections for both first and second mode and the relatively low frequency of the first and second torsional modes (12 and 20 rad/sec, respectively, at Stage 0 start).

To attain the PIBOL rate channel requirements, it was necessary to use the system shown in block diagram form in Fig. 20. For operation in the standard Titan III/X-20A mode, Switch S_1 is open and S_2 closed, providing the displacement (K_D) and rate (K_{R2}) feedbacks necessary in that system. For PIBOL, Switch S_1 is closed, providing the additional rate gain, K'_{R2} . Switch S_2 may be open or closed for PIBOL, because the PIBOL handling characteristic requirements allow a displacement channel gain of zero, and the stability margins are not greatly affected by removal of the displacement signal.

Table 6 Roll Channel Handling Characteristic Results

System	PIBOL Gain Requirements (2)		Standard Titan III/X-20A Roll Gains		PIBOL Rate Channel Gain (K'_{R2})	Total PIBOL Rate Gain ($K_{R2} + K'_{R2}$)
	K_R	K_D	K_{R2}	K_D		
Stage 0						
0 to 30 sec	$0.536 \leq K_R \leq 1.37$	$K_D \geq 0$	0.25	0.55	0.40	0.65
30 to 80 sec	$0.412 \leq K_R \leq 0.669$	$K_D \geq 0$	0.16	0.55	0.34	0.50
80 sec to Burnout	$0.201 \leq K_R \leq 0.356$	$K_D \geq 0$	0.12	0.55	0.13	0.25
Stage I	$0.15 \leq K_R \leq 0.5$	$K_D \geq 0$	0.16(4)	0.30	0	0.16(4)
Stage II	$7.72 \leq K_R \leq 23.1$	$K_D \geq 0$	15	30	0	15
Stage III	$0.85 \leq K_R \leq 8.5$	$K_D \geq 0$	0.8(3)	0.8	Unknown (1)	--

- Note:**
1. Stage III rate gain not evaluated because Stage III torsional data is not available.
 2. Gain requirements calculated from requirements stated in Table 2 and nominal vehicle characteristics.
 3. Stage III of Titan III uses a derived rate system operating on the IGS signal, thus the rate channel gain for PIBOL is independent of this equivalent rate gain.
 4. In an actual PIBOL usage, the standard Titan III/X-20A roll-rate gain could be raised to optimize the PIBOL system, without penalizing either the standard or PIBOL system.

To avoid stability margin degradation because of the added PIBOL rate gain (K'_{R2}), it is necessary to filter the K'_{R2} signal very heavily. The value chosen for the filter break frequency, ω , was 1 rad. Open-loop frequency response plots with the displacement channel gain at zero are shown in App C. Table 6 shows the values chosen for K'_{R2} to meet the PIBOL requirements. While this method of meeting the roll rate gain requirement meets the PIBOL specifications, it might not provide desirable handling characteristics. It appears that roll requirements specified in the same manner as the pitch and yaw requirements are advisable for future PIBOL applications. This matter is discussed in greater detail in Appendix J.

SSD-CR-64-32

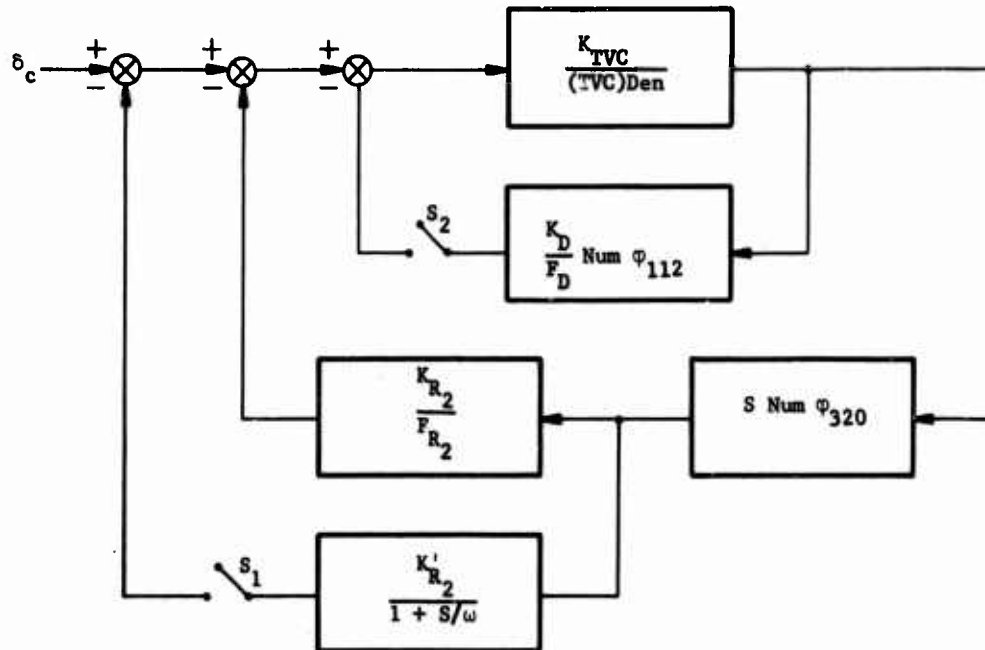
**Legend:**

δ_c	Pilot Command	F_D	Denom of Filter in K_D Loop
K_{TVC}	Equiv TVC Gain	F_{R_2}	Denom of Filter in K_{R_2} Loop
(TVC)	Den of TVC Transfer Function	S	Laplace Operator
Num ϕ_{112}	Numerator of Airframe Transfer Functions at Sta 112 and 320	K'_{R_2}	Rate Gain in Channel Added for PIBOL
Num ϕ_{320}		ω	Break Frequency of Filter in Channel added for PIBOL
K_D	Displ Channel Gain	S_1, S_2	PIBOL Switches: S_1 Open, S_2 Closed = Standard System; S_1 Closed, S_2 Open or Closed = PIBOL
K_{R_2}	Standard Titan III/X-20A Rate Channel Gain		

Fig. 20 Stage 0 Roll Axis Block Diagram

Stage III of the PIBOL configuration requires roll-rate gains slightly higher than the equivalent rate gain provided by the standard Titan III/X-20A configuration (Table 6). The exact gain level to be used for PIBOL will depend on the torsional bending characteristics of the vehicle. Since no torsional bending data were developed for Stage III of the Titan III/X-20A configuration before the X-20A program cancellation, no exact gain is provided. However, no problems are anticipated in meeting the PIBOL requirements.

d. Tolerance Evaluation

Method of Evaluation - The evaluation of the effects of tolerances on the PIBOL systems was conducted in a manner that relied on previous tolerance studies of the standard Titan III/X-20A flight control system.

The effect of tolerances on the pitch axis handling characteristics and stability margins was evaluated only on the approximate-integral system for the Stage 0 Basic PIBOL concept, for the Stage 0 Broader PIBOL configuration, and for the upper stages with the displacement channel gain equal to zero. Roll tolerances were evaluated only from the handling characteristic standpoint, and then only to assure that the nominal rate gains were far enough from the requirements to avoid tolerance problems. Stability margins on the PIBOL roll systems are identical to those of the standard Titan III/X-20A configuration and are affected by tolerances in a similar acceptable manner.

The effect of tolerances on Stage 0 handling characteristics (Basic and Broader) was evaluated at only 60 sec, since this represents the point of maximum difficulty for the pilot. Tolerance effects on handling characteristics of the upper stages were evaluated only at the start conditions for each Stage, since handling characteristics at those time points were closest to the required boundaries.

The tolerance effects on stability margins were also evaluated at 60 sec for both Stage 0 systems, since it was believed that the tolerance sensitivity could be established at a single time point. Tolerance effects on the Stage I stability margins were also evaluated at burnout for comparison with previous tolerance studies. Stage II stability margin tolerance sensitivities were not evaluated because the stability margins were unchanged from those of the standard Titan III/X-20A flight control system. Evaluation of Stage III tolerances was not necessary, because the system without either rate or displacement channel gain cannot be affected by tolerances.

To assess the influence of tolerances on handling characteristics or stability margins, it was necessary to determine the variation in the result (handling characteristic or stability margin) related to a change in each system parameter. The resulting changes were then root-sum-squared to obtain a realistic picture of the tolerance sensitivity of each important characteristic of the system.

Tolerance Study Results - The tolerance study showed that the handling characteristics for the Stage I and Stage II systems do not vary greatly with the application of tolerances. These variations are shown in App E. The variation of handling characteristics due to tolerance effects for the two Stage 0 systems evaluated are shown in Fig. 21 and 22. The Stage 0 recommended system shows the largest effect occurring on the $2\zeta\omega_n$ parameter. The tolerance effects on this system are believed to be acceptable. The only way for the handling characteristic boundary to be crossed, due to tolerance effects, is to have both parameters (ω_n^2 and $2\zeta\omega_n$) vary simultaneously to their lower extremes. The probability of these events occurring simultaneously is low.

The tolerance sensitivity of the Broader system (Fig. 22) is more critical. Although the variations due to tolerances are smaller than on the recommended Basic system, the nominal operating point is closer to the handling characteristic boundary, and the probability of crossing the boundary is large enough to cause concern. Data from which these variations were determined are included in App E.

The results of the evaluation of tolerance effects on stability margins of the Stage 0 approximate integral Basic system showed that the system was comparable to the standard Titan III/X-20A control system, in that the root-sum-square total of tolerance effects on the first structural mode stability margins would not cause the system to become unstable. The data and individual sensitivities are tabulated in App E.

A similar desirable result was obtained on the Stage I stability margin tolerance evaluation (data in App E).

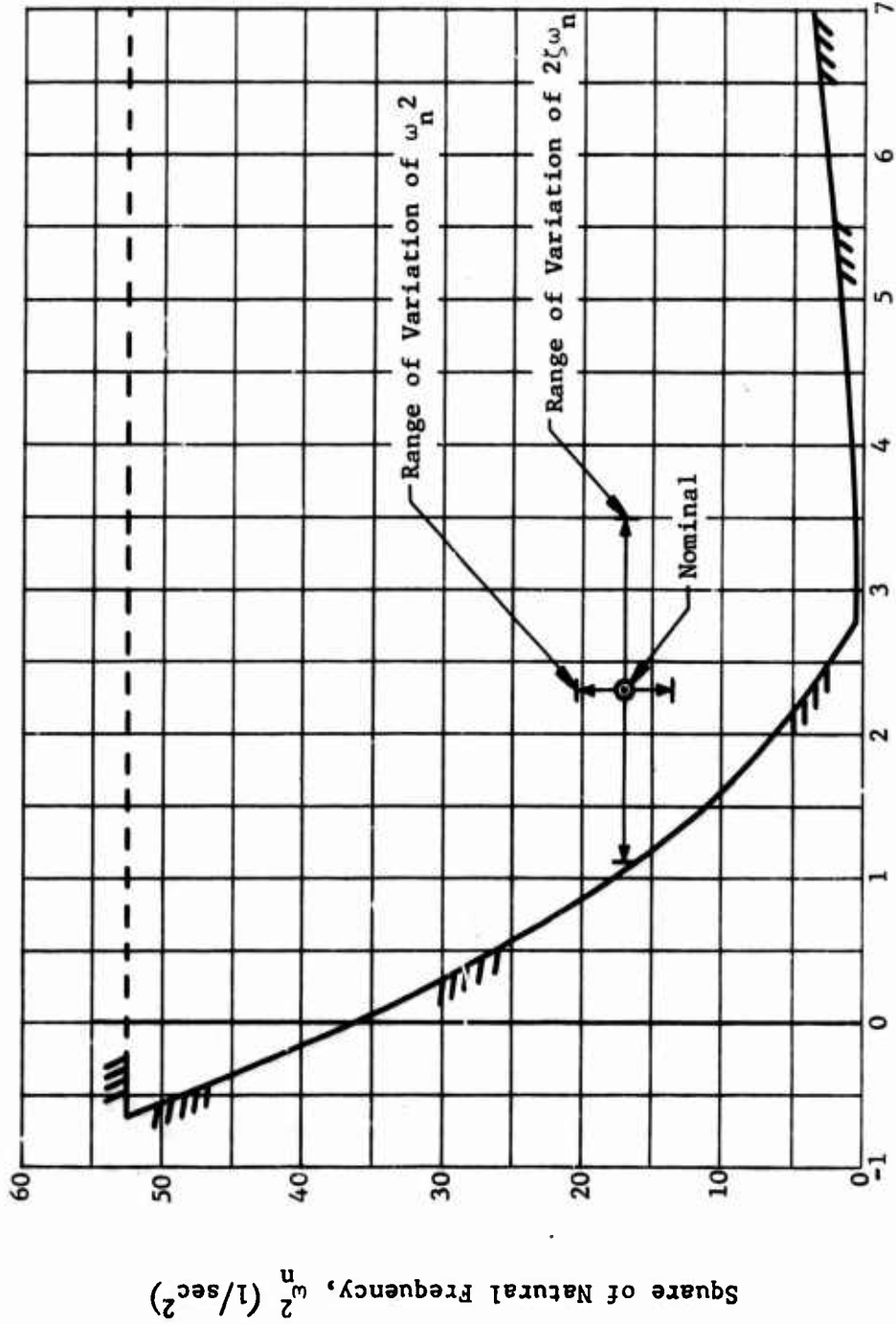

Twice the Product of Damping Ratio and Natural Frequency, $2\zeta\omega_n$ (l/sec)

Fig. 21 Basic System Handling Characteristic Variation due to Tolerances
(Stage 0 Pitch Axis 60 sec Recommended System)

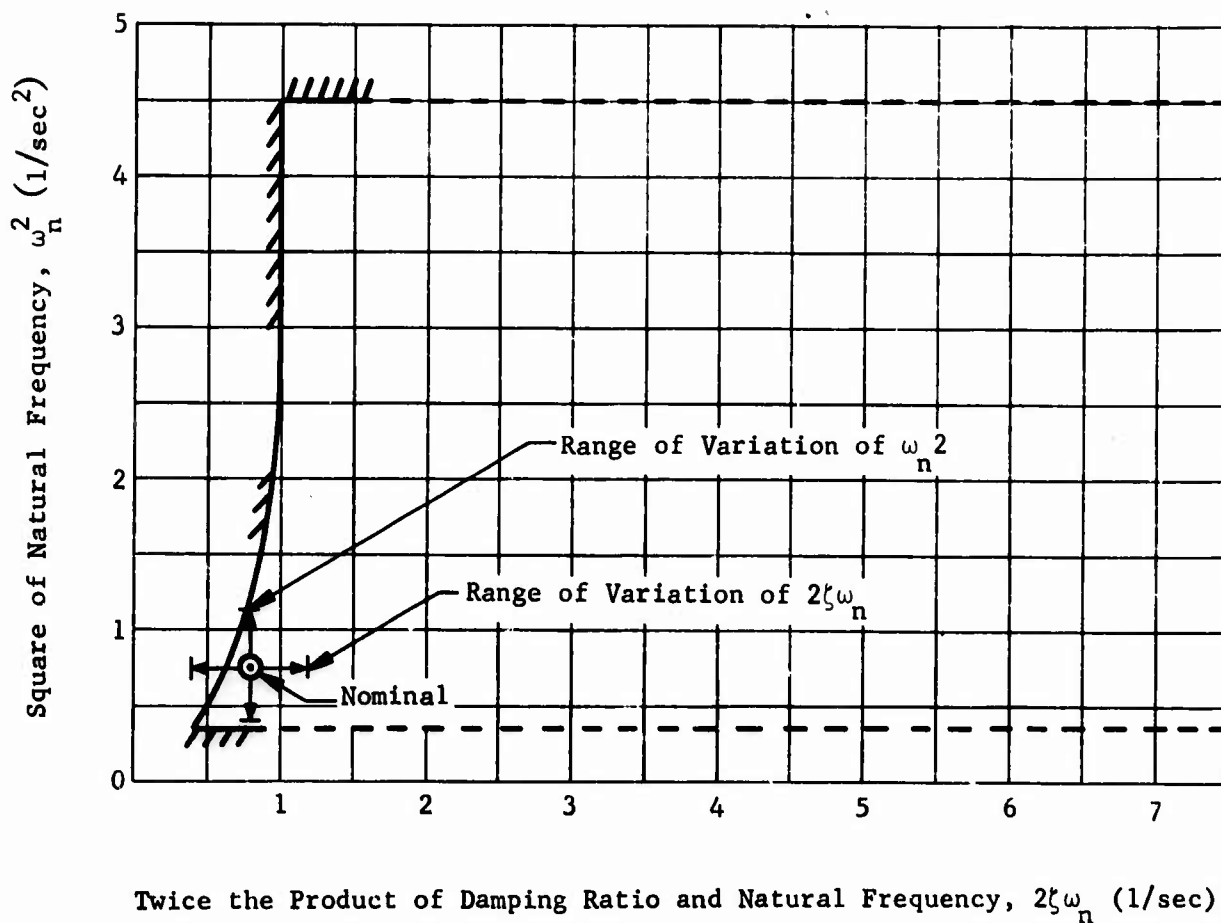

Fig. 22 Broader System Handling Characteristic Variation Due To Tolerances (Stage 0, Pitch Axis, 60 sec)

The evaluation of tolerances on the Broader Stage 0 stability margins presented much different results. A summation of the tolerance effects on the first structural mode stability margins showed that the margin could be reduced by as much as 97.5 deg due to tolerances. This is completely unacceptable, since in some cases, less than 40 deg of margin exist. The tolerance sensitivities are summarized in App E. With the large rate channel gains required for Broader PIBOL, no method of reducing the tolerance sensitivities was found.

The effects of tolerances on the roll handling characteristics was evaluated as follows. The only variables of concern (Table 3) are thrust ($\pm 5\%$), roll moment arm (± 2 in.), inertia ($\pm 10\%$), and rate channel gain ($\pm 10\%$). The root-sum-square value of these tolerances is approximately $\pm 15\%$. For each PIBOL gain ($K_{R2} + K'_{R2}$), except the Stage I gain, there is adequate margin for a 15% variation. For Stage I, the roll rate gain must be increased to at least 0.18 to avoid tolerance problems. For the Titan III/X-20A configuration, a gain of 0.18 can easily be accepted for both the standard and PIBOL modes.

Tolerance effects on roll axis stability margins during all phases of flight, and Stage II pitch and yaw stability margins were not evaluated because the PIBOL effects are identical to those of the standard Titan III system. During these phases of flight the stability margins are determined only by the rate channel response, which is unchanged for PIBOL.

B. AIRBORNE SYSTEM MECHANIZATION STUDIES

The Titan III guidance and flight control system, which must be adapted to any PIBOL mechanization, consists of two major groups. These are the booster inertial guidance system (BIGS) and the flight control system (FCS).

The primary function of the inertial guidance system is to generate the steering commands that steer the vehicle along its required trajectory. Two secondary functions of the guidance system are: the generation of the discrete signals that cause various required events during flight, either on the basis of time after liftoff, attained velocity, or acceleration, and the measurement of vehicle attitude for use in the vehicle attitude control system.

The discrete signals are originated in the airborne digital computer, and are imposed on the vehicle controls as the closing of a circuit path to ground through solid-state circuitry. Eleven discrete signals are combined in the vehicle electrical system to cause 17 events. The flight sequence is described in Table 7.

The vehicle attitude signals are 3 dc voltages from -5.45 to +5.45 volts in roll and from -11.07 to +11.07 volts in pitch and yaw, corresponding to 1 deg of departure from the commanded attitude for each volt of signal.

The function of the vehicle flight control system is to accept the attitude error signals, which include steering commands as periodic shifts in the attitude reference, to command the solid motor thrust vector control system and the gimballed engines of the upper stages.

The flight control system consists of the hydraulic systems that provide the forces to move the thrust chamber, two rate gyro systems that measure the vehicle angular velocities (to provide rate damping in the control system), a lateral acceleration sensing system (LASS) that measures lateral accelerations during part of Step 0 flight, and two enclosures that contain the electronics to interpret the various signals and command the hydraulic servos.

One electronic enclosure, the computer, contains all of the amplifiers required. The other, the adapter programmer, contains relays and networks to establish the signal routing and transfer function during the various flight conditions.

In the standard space booster concept, changes to the flight control system to accommodate the various payloads and missions are made in the adapter-programmer.

In the basic PIBOL flight mode the pilot elects to assume the guidance, or navigation, function of the BIGS by switching the guidance system out of operation. The sequencing and attitude reference functions of the BIGS must be transferred to other apparatus, because the guidance system is assumed to be totally disabled.

As a portion of this study a solid-state sequencer was designed to replace the sequencing function of BIGS. This apparatus will duplicate the discrete signals supplied by the guidance computer. A signal transfer switch will transfer the 11 discrete signal inputs to the vehicle sequence system from BIGS to the PIBOL sequencer. An accelerometer package is also installed to provide signals to the pilot's displays (based on the Boeing study, Ref 1).

Table 7 Representative Flight Sequence

Typical Time*	Flight Period	Discrete and State	Event Referenced to**		Source of Signal		Results	
			Standard Titan III Mode	PIBOL Mode	Standard Titan III Mode	PIBOL Mode		
T+25	Stage 0	No. 1 On	Timed from L/O	Timed from L/O	BIGS	PIBOL Sequencer	a) MDS S/D Enable	
T+30		No. 2 On	Timed from L/O	Timed from L/O	BIGS	PIBOL Sequencer	a) A/P Gain Change No. 1	
T+80		No. 3 On No. 2 Off	Timed from L/O Coincident with No. 3 On	Timed from L/O Coincident with No. 3 On	BIGS	PIBOL Sequencer	a) A/P Gain Change No. 2 b) Operate TPS Power Switch c) Remove Gain Change No. 1	
T+105	Stage I	No. 4 On	Will Occur within 1 sec after Acceleration Level Drops to X g	Will Occur within 1 sec after Acceleration Level Drops to X g	BIGS	PIBOL Sequencer	a) Start Stage I Engine b) Disable SRM Inadvertent Destruct c) MDS SRM Bypass	
T+115		No. 3 Off No. 5 On No. 4 Off	Timed from No. 4 Discrete On Coincident with No. 3 Off Coincident with No. 3 Off	Timed from No. 4 Discrete On Coincident with No. 3 Off Coincident with No. 3 Off	BIGS	PIBOL Sequencer	a) Remove Gain Change No. 2 b) Stage O/I Separation Ordnance c) A/P Gain Change No. 3	
T+185		No. 6 On No. 5 Off	Predicted Stage I S/D (Will Occur X sec before Predicted Time of Stage I S/D) Coincident with No. 6 On	Timed from No. 4 Discrete On Coincident with No. 6 On	BIGS	PIBOL Sequencer	a) A/P Gain Change No. 4 b) Remove Gain Change No. 3	
T+250		No. 7 On	Predicted Stage I S/D (Will Occur X sec before Predicted Time of Stage I S/D)	Timed from No. 4 Discrete On	BIGS	PIBOL Sequencer	a) Disable Stage I Inadvertent Destruct b) Enable TCPS and Low-Level Sensor Shutdown	
T+255		Stage I LLS or TCPS	Fuel Low-Level Sensor or Thrust Chamber Pressure	Fuel Low-Level Sensor or Thrust Chamber Pressure	Fuel Low-Level Sensor or Thrust Chamber Pressure Switches	Fuel Low-Level Sensor or Thrust Chamber Pressure Switches	a) MDS Sensor Bypass b) A/P Gain Change No. 5 c) Stage I I Separation Ordnance d) Shutdown Stage I Engine e) Interrupt Gain Change No. 4 (within A/P) f) Stage II Start g) Pressurize Stage III Tanks to Flight Pressure	
T+350	Stage II	No. 8 On	Predicted Stage II S/D (Will Occur X sec before Predicted Time of Stage II S/D)	Timed from Stage I LLS or TCPS	BIGS	PIBOL Sequencer	a) Payload Fairing Release (Not Applicable to Dyna-Soar, but Must be Issued)	
T+453		No. 6 Off No. 7 Off No. 9 On	Timed from No. 8 On Coincident with No. 6 Off Predicted Stage II S/D (Will Occur X sec before Predicted Time of Stage II S/D)	Timed from No. 8 On Coincident with No. 6 Off	BIGS	PIBOL Sequencer	b) Remove Gain Change No. 4 Command a) Stage II Shutdown Enable	
T+458		No. 8 Off No. 10 On	Timed from No. 9 On Will Occur when Vehicle Velocity Reaches X fps	Timed from No. 9 On Will Occur when Vehicle Velocity Reaches X fps	BIGS BIGS	PIBOL Sequencer Pilot	a) Guidance Shutdown of Stage II b) Bypass Stage II MDS Sensor c) Enable Attitude Control Nozzles d) Propellant Settling and Stage III Hydraulic Start e) Remove Stage III Tank Pressure f) Disable Stage II Inadvertent Separation Destruct System	
T+460		No. 5 Off No. 10 Off	Timed from No. 10 Discrete On Timed from No. 10 Discrete On	Timed from No. 10 Discrete On Timed from No. 10 Discrete On	BIGS BIGS	PIBOL Sequencer PIBOL Sequencer	a) Clear Discrete Matrix (Propellant Settling and Hydraulic Start Locked In)	
T+462		No. 1 Off	Timed from No. 10 Discrete On	Timed from No. 10 Discrete On	BIGS	PIBOL Sequencer	a) Reset Discrete Matrix	
T+464		No. 2 On	Timed from No. 10 Discrete On	Timed from No. 10 Discrete On	BIGS	PIBOL Sequencer	a) Hold T/N On	
T+467		No. 4 On No. 3 On	Timed from No. 10 Discrete On Coincident with No. 4 On	Timed from No. 10 Discrete On Coincident with No. 4 On	BIGS BIGS	PIBOL Sequencer PIBOL Sequencer	a) Propellant Settling and Stage III Hydraulic Start b) Fire Stage II/III Separation Ordnance c) Interrupt Propellant Settling and Hydraulic Start Command from Stage II Shutdown Bus d) Remove Gain Change No. 3	
T+470		No. 5 On	Timed from No. 10 Discrete On	Timed from No. 10 Discrete On	BIGS	PIBOL Sequencer	a) Apply Gain Change No. 7 b) Start Stage III Engines c) Disable Attitude Control Nozzles d) Pressurize Stage III Tanks	
T+512		Stage III	No. 5 Off No. 4 Off No. 11 On	Guidance Equations Coincident with No. 5 Discrete Off Timed from Liftoff	Pilot Coincident with No. 5 Discrete Off Timed from Liftoff	BIGS BIGS BIGS	PIBOL Sequencer (Initiated by Pilot) PIBOL Sequencer (Some as Above) PIBOL Sequencer	a) Shutdown Stage III b) Enable Attitude Control Nozzles c) Remove Stage III Tank Pressure d) Stop Hydraulics, Remove Propellant Settling e) Turn Off Command Receivers and Rate Beacon
T+514			No. 9 On	Timed from No. 5 Discrete Off	Timed from No. 5 Discrete Off	BIGS	PIBOL Sequencer	a) Send Spacecraft Separation Discrete b) Disable Attitude Control Nozzles c) Enable Spacecraft Release
T+518	No. 10 On		Timed from No. 5 Discrete Off	Timed from No. 5 Discrete Off	BIGS	PIBOL Sequencer	a) Fire Transstage Retro-rockets b) Turn Off Tracking Subsystem	
T+528	No. 2 Off	Timed from No. 5 Discrete Off	Timed from No. 5 Discrete Off	BIGS	PIBOL Sequencer	a) T/N Off		

*Times are not actual flight times, but represent the proper sequence throughout flight.
**All times designated "X" are predetermined for each flight.

In the recommended PIBOL system, attitude reference for the flight control system is supplied by integrating (approximately) the existing Stage II rate gyro output. A mechanization concept for a Basic system with displacement gyros to obtain the attitude reference was also evaluated during the study, and is presented in App H. While this system met the PIBOL requirements, the mechanization is not as simple as that for the recommended PIBOL system.

The mechanization approach attempted for Broader PIBOL is also presented in App H. Although the mechanization concept is not extremely complex, the Broader system could not meet all performance requirements (Chap. III.A.).

1. System Description

The recommended PIBOL mechanization concept is shown in Fig. 23. The standard Titan III system is shown for comparison in Fig. 24. The recommended PIBOL system requires the addition (to the standard Titan III) of the following components:

- 1) The signal selector switch, which is used to remove the BIGS signals from the vehicle electrical system and applies the PIBOL signals;
- 2) The PIBOL sequencer, which provides the time-based and acceleration-based signals normally provided by the booster inertial guidance system;
- 3) The Stage III rate gyro system, which provides the roll rate signal required during Stage III operation;
- 4) The Stage I lateral acceleration sensing system, which is used to provide a display of lateral acceleration to the pilot.

2. PIBOL Adapter Programmer

The adapter-programmer for the recommended PIBOL system is a modification of the standard Titan III adapter-programmer. The following modifications have been made to the adapter-programmer to adapt the standard Titan III flight control system to the recommended PIBOL system:

- 1) Capability for disabling the attitude signals from the BIGS and switching to PIBOL circuitry on receipt of the transfer command from the pilot;

- 2) Modification of the LASS integrator to provide approximate integration of the Stage II pitch and yaw rate gyro outputs for attitude reference during Stage 0;
- 3) Modification of the dynamic network associated with the roll displacement amplifier that provides the roll rate channel configuration required for Stage 0 flight;
- 4) Addition of relay contacts and gain change resistors to provide the three gain states required for the pitch and yaw attitude reference signals (integrated rates);
- 5) Addition of relay contacts and gain change resistors to provide the roll rate gain states required for Stage 0 flight;
- 6) Modification of the dynamic network of the Stage III roll derived rate amplifier, including the addition of a gain resistor to use the existing amplifier for the roll rate gyro requirements during Stage III flight;
- 7) Addition of interconnections required to connect the pilot command (from glider) to all valve-drive amplifiers and addition of summation resistors to sum the pilots commands with Stage II pitch and yaw rates for Stage 0 flight.

The approximate integration of the Stage II rate gyro signals (Fig. 25, Circuit 103) during Stage 0 flight is accomplished in existing flight control system hardware. Since the acceleration channels (load relief) are not required for Basic PIBOL, the integration circuitry in those channels may be used for the approximate integration of the rate signals. This choice was made to reduce the number of components added for PIBOL. The circuitry that determines the integrator characteristics is altered (by Switch P5) for Basic PIBOL and connected to the output of the Stage II rate gyros [through Resistor R4(p)]. For the standard Titan III flight control system (without PIBOL), the integrator (with Switch P5 open) has the transfer function,

$$G(S) = \frac{K(1 + \tau S)}{1 + \frac{2\zeta}{\omega} S + \frac{S^2}{\omega^2}}$$

which is required for load-relief operation. This circuit functions only from 30 to 80 sec, when the contacts of Relay 103K1 are closed. Relay contacts S1 are used only during ground check-out to decrease the integrator time constant.

For Basic PIBOL, the integrator will be changed as shown in Fig. 25. Relay contacts P4 and P5 will be closed on entering the PIBOL mode. The closure of P5 changes the integrator transfer function to,

$$G(S) = \frac{K'}{1 + \tau'S'}$$

With the component part values chosen for the standard Titan III/X-20A flight control system, τ' becomes 5.32 sec, which falls within the range required by the analysis in Chap. III.A.3. Resistors 103R1(P), 103R2(P), and 103R3(P) provide the three different gains required during Stage 0 flight, with relay contacts P1, P2, and P3 controlling which resistor is in use. Relays P1, P2, and P3 are controlled by the vehicle sequencer. When relay contact P4 is closed (on entering the PIBOL mode) to connect the Stage II rate signal, relay contacts P8, in series with N.O. contacts of 103K1, are opened, which disconnects the signals from the accelerometer.

The circuitry required to implement the change required in the roll rate channels during Stage 0 operation is obtained by routing the Stage II roll rate gyro signal through a gain change network to the unused (for PIBOL) roll displacement channel (Circuit No. 163) as shown in Fig. 25.

Resistors 163R1(P), 163R2(P), and 163R3(P) provide the three different roll rate gains required during Stage 0 flight, with contacts P11, P12, and P13 controlling which resistor is in use. On entering the PIBOL mode, contact P6 closure connects the Stage II roll rate gyro output to the roll displacement amplifier. One capacitor, 165C1(P), and one set of relay contacts (P7) added to the roll amplifier provide the low frequency filter (1 rad lag) necessary for the required dynamics. This modification is used in addition to the normal Titan III rate channel circuitry.

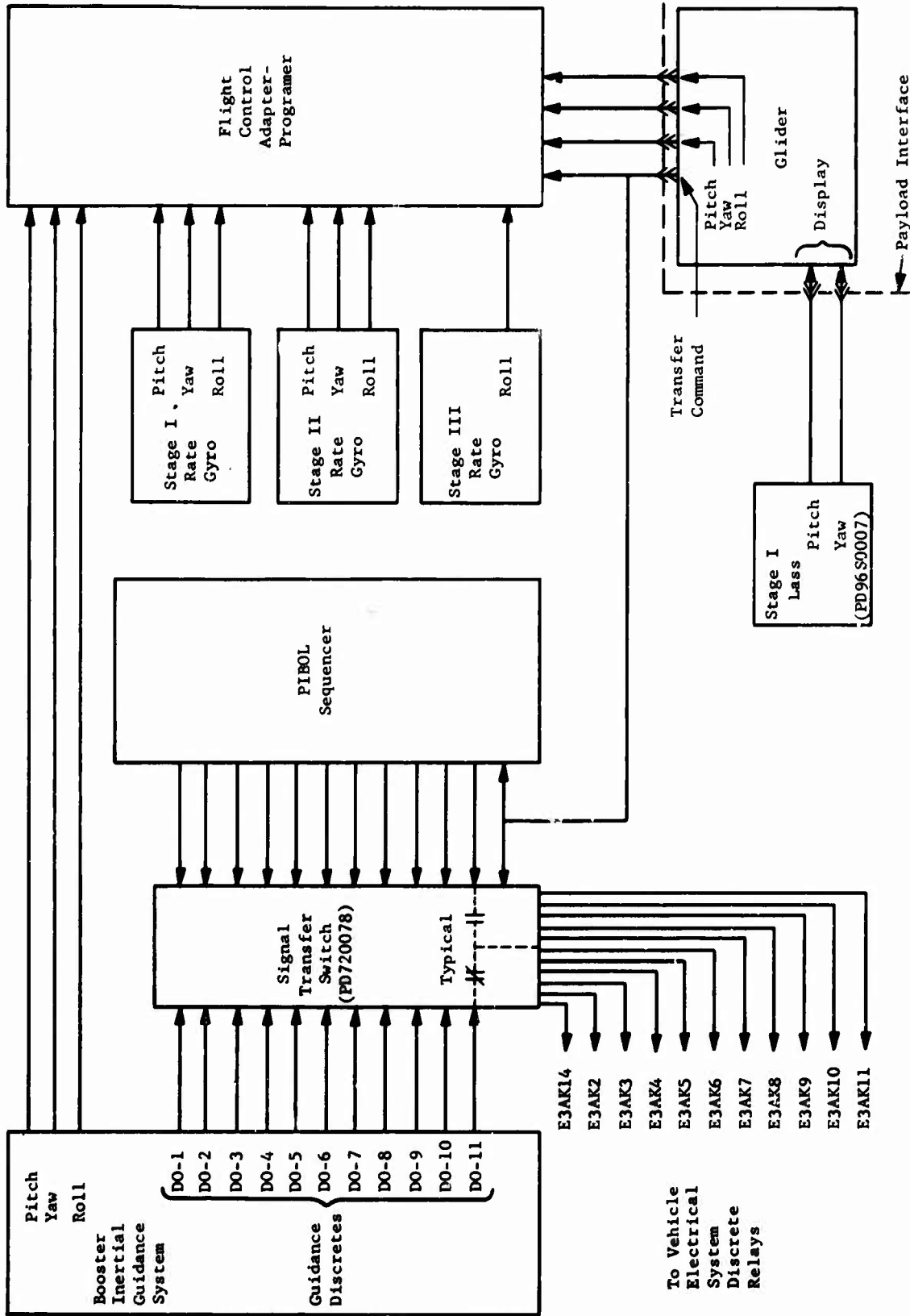

Fig. 23 Recommended PIBOL System Block Diagram

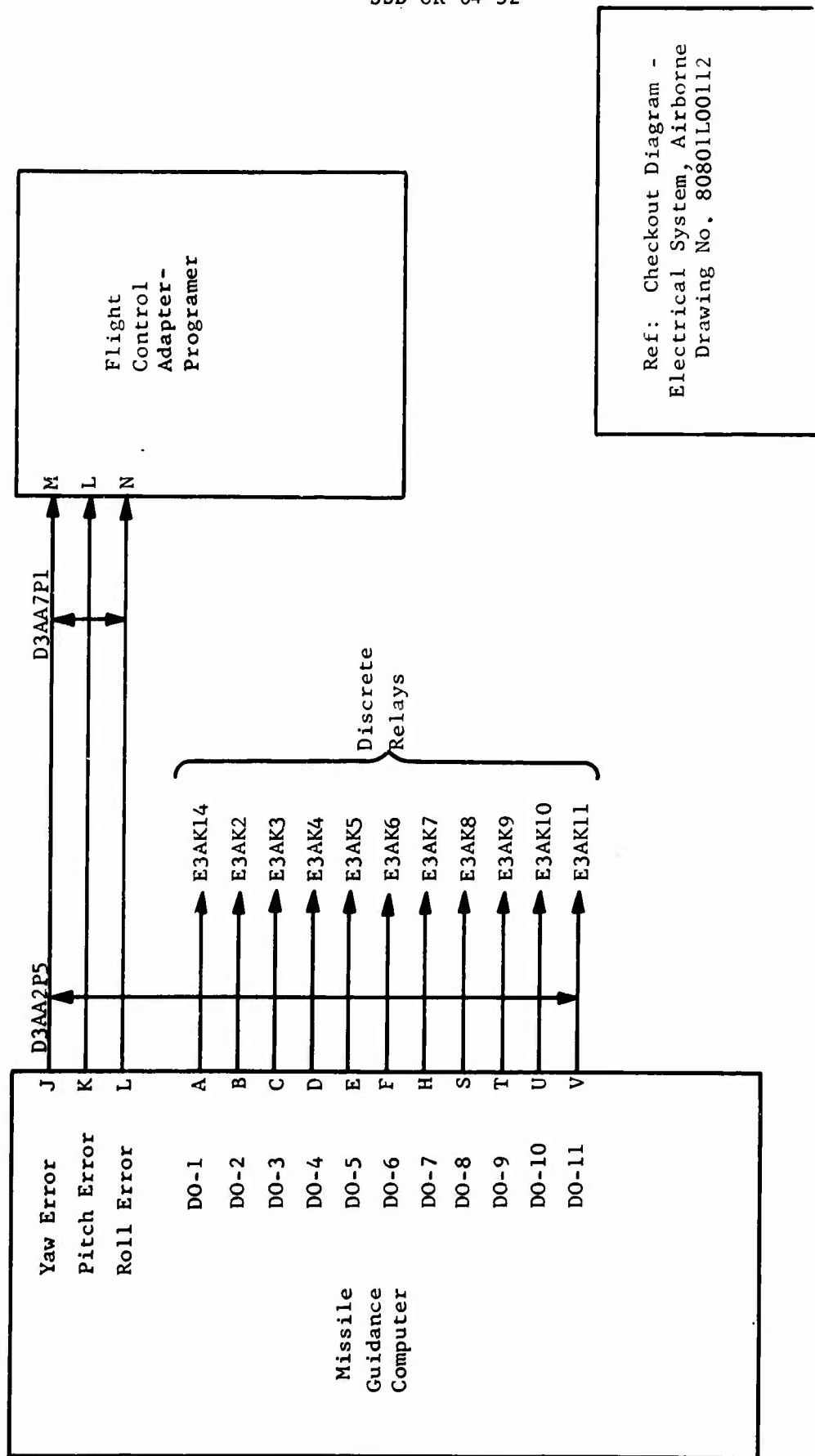

Fig. 24 Present Titan III Configuration

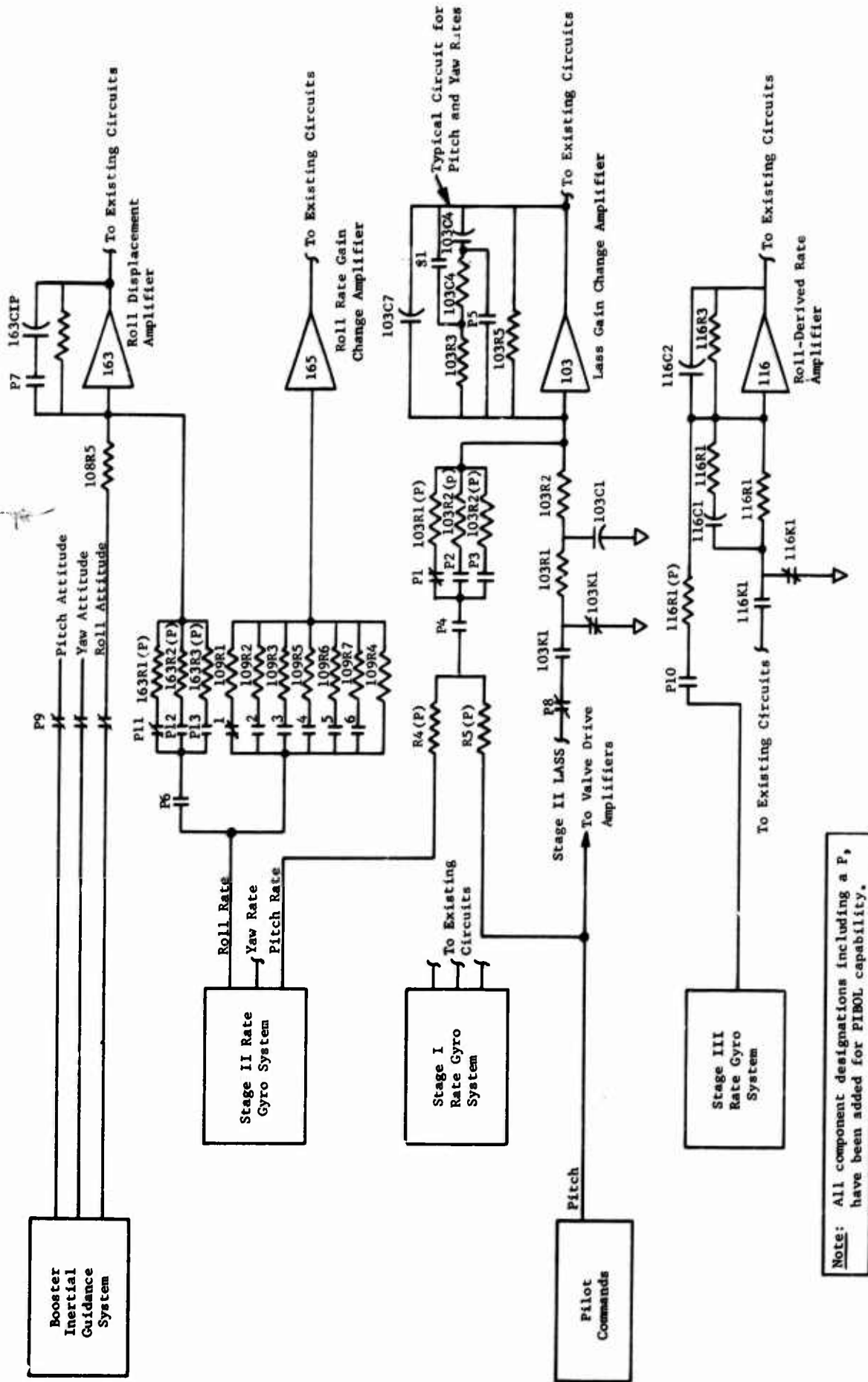

Fig. 25 Recommended Basic PIBOL Adapter-Programmer Configuration

Analysis showed that handling characteristic and stability margin requirements for pitch and yaw were met with the displacement channel gain set at zero for Stages I and II. The displacement gains are set at zero by virtue of the fact that PIBOL Switch P9 disconnects the attitude signals from BIGS on entering PIBOL mode. Stage III pitch and yaw requirements are met with both the displacement and rate channel gains at zero (open loop), accomplished by PIBOL Switch P9, and the fact that no pitch and yaw rate gyros are used during Stage III flight.

During Stage III operation, the standard Titan III flight control system derives an equivalent rate signal from the IGS attitude error signal (Circuit No. 116). Since this signal is removed in the PIBOL mode, a Stage III roll rate gyro is needed for Stage III operation. The gain on this signal can then be set at a level compatible with PIBOL requirements, the exact value depends on torsional bending characteristics. Relay contacts P10 connect the Stage II roll rate gyro to the modified roll derived rate amplifier, and Resistor 116R1(P) determined the roll rate gain.

3. PIBOL Sequencer

The PIBOL sequencer must be capable of providing the same discrete signals to the vehicle, based on time and acceleration, as the BIGS provides. In addition, it must be capable of taking over from the BIGS at any time, up to payload release. The discrete signals normally provided by the BIGS are shown in the representative flight sequence shown in Table 7. Although the BIGS provides only 11 discrettes, various combinations of the 11 result in many more resulting events. This is accomplished in the vehicle electrical system. These BIGS signals are generated with an accuracy of ± 1 sec, which is also adequate for the PIBOL sequencer.

The PIBOL sequencer also supplies all of these discrettes previously provided by the BIGS, except those occurring to shutdown Stage II and Stage III. The pilot, by consulting his displays, can provide these shutdown signals as indicated by Ref 1.

Figure 26 shows a block diagram of the sequencer mechanization diagram concept. The DC filter aids in providing a supply of uninterrupted DC power to the other circuits in the package. The 16-cps oscillator provides the time base for the sequencer. The binary networks count down on the 16-cps oscillator signal to provide the various time increments required for the sequencer operation. The diode matrix and relay and driver system provide the logic needed to generate the required signals. The acceleration switch provides the signal required to start the Stage 0/ Stage I staging sequence when the Stage 0 solid rocket motor thrust begins to decay.

Figure 27 shows the sequencer logic provided by the diode matrix and the relay and driver system.

At liftoff (L/O), a +28-volt signal is removed from the sequencer reset relays and from the L/O disable logic, which results in the loss of voltage at the input to the diode matrix for those L/O-dependent time functions, thereby enabling them. Simultaneous with the removal of this +28-volt signal is the initiation of the sequencer time base oscillator (timer start). At L/O +25 sec, the loss of +28 volts from one of the 19 diode matrix outputs results in discrete No. 1 being issued, which is MDS shutdown enable. Similarly, at L/O +30 sec, discrete No. 2, FCS gain change is issued. At L/O +80 sec, discrete No. 2 is disabled and discrete No. 3, FCS gain change is issued. The sequencer timer is stopped, the binaries are reset, and L/O disabled.

At Stage 0 thrust decay (\ddot{S}), the acceleration switch in the PIBOL sequencer closes, removing the \ddot{S} disable input to the diode matrix and enabling all \ddot{S} functions. Discrete No. 4, start Stage I engines, is issued at this time. At $S + 10$ sec, discrete No. 3 and discrete No. 4 are disabled, and discrete No. 5, initiate separation ordnance, is issued. At $\ddot{S} + 80$ sec, discrete No. 6, FCS gain change, is issued, and discrete No. 5 is disabled. Discrete No. 7, enable low-level sensor shutdown, \ddot{S} disable to the matrix, timer stop, and binary reset are all issued at $\ddot{S} + 145$ sec.

When the Stage I low level sensor (LLS) operates (at fuel depletion), +28 volts is removed from the LLS disable logic, which enables all LLS-dependent functions and starts the sequencer timer. At LLS +95 sec, discrettes No. 6 and 7 are disabled and discrete No. 8, payload fairing release, is issued. At LLS +198 sec, discrete No. 8 is disabled and discrete No. 9, Stage II shutdown enable, is issued simultaneously. The timer is stopped and the binaries are reset.

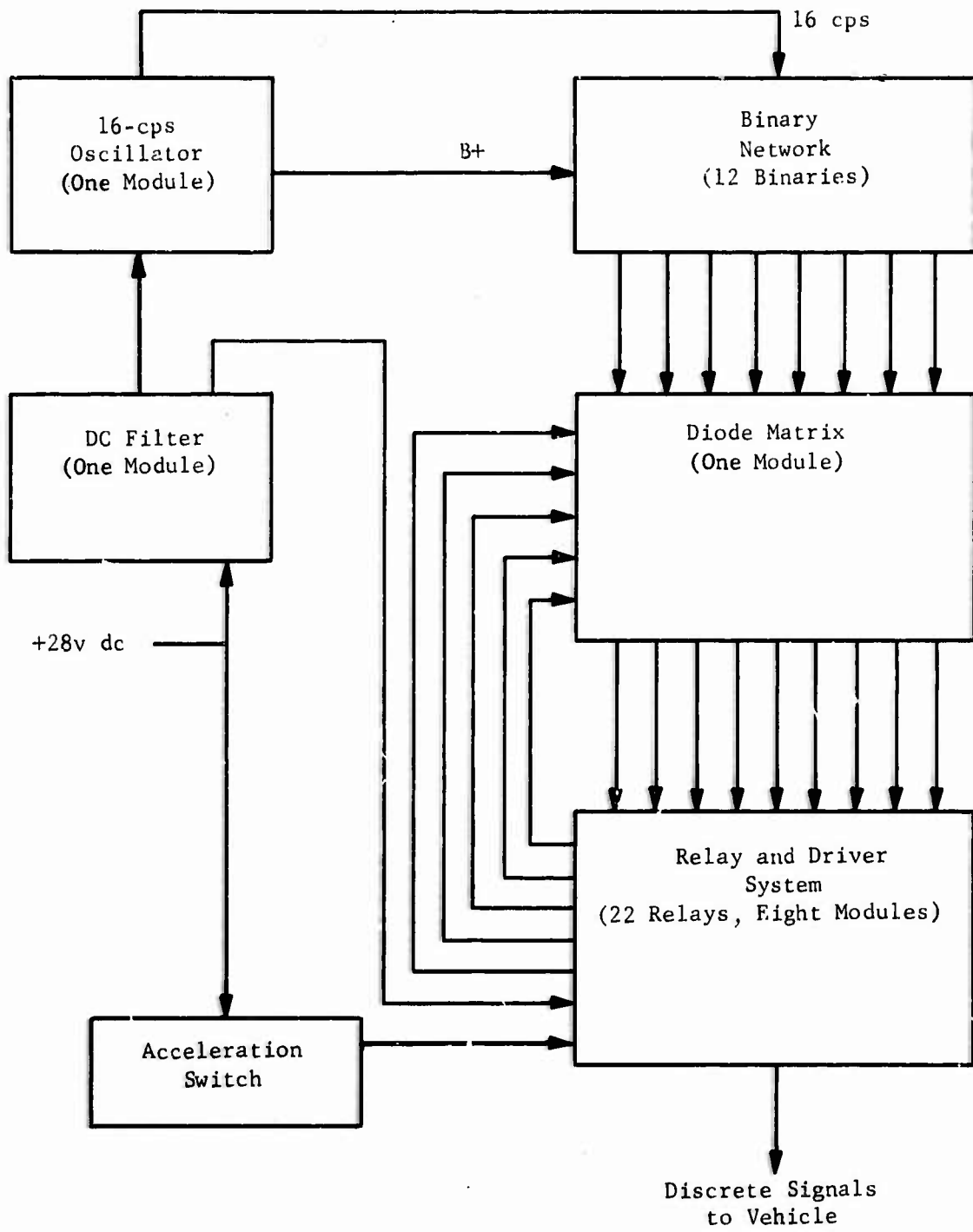

Fig. 26 Block Diagram - PIBOL Sequencer

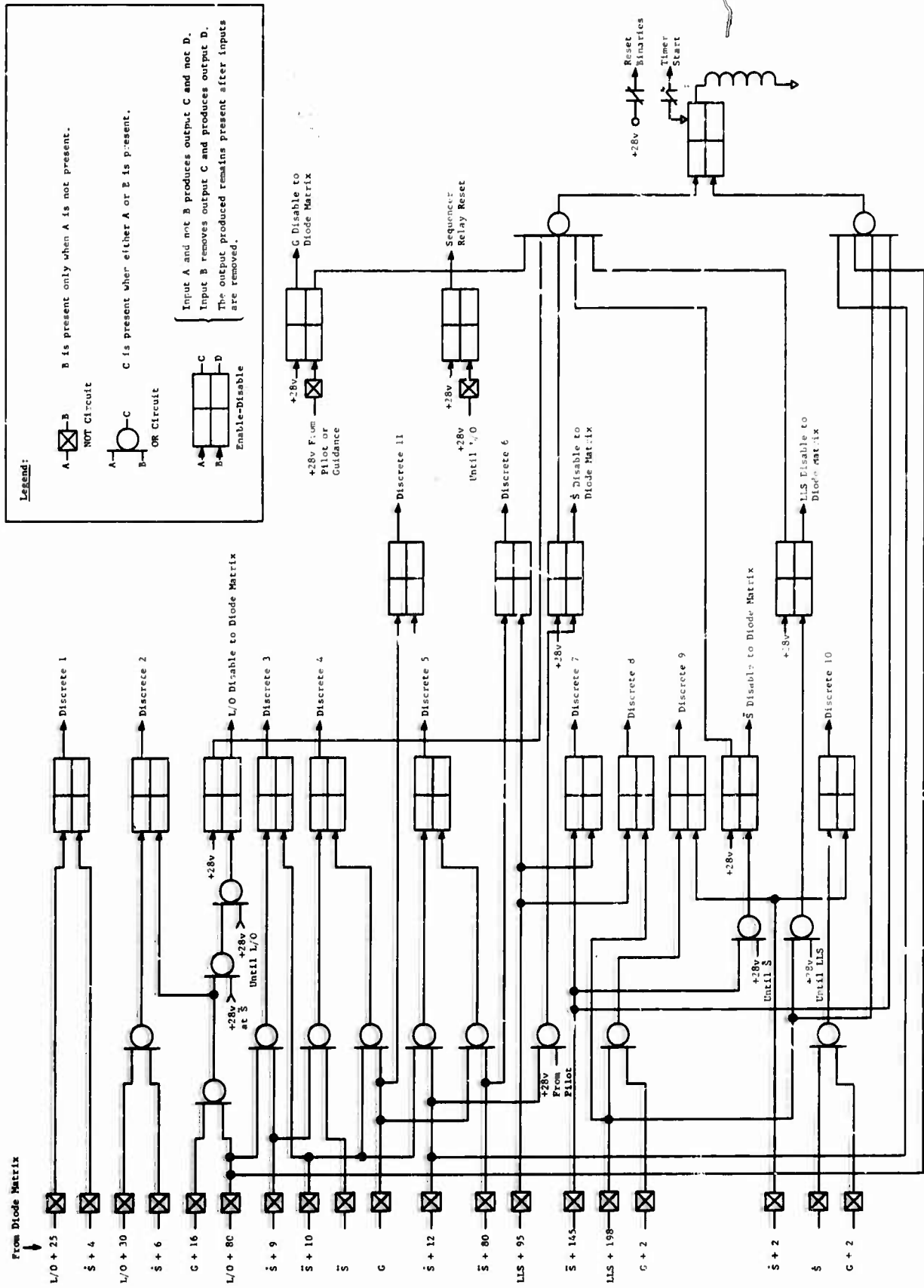

Fig. 27 PI80U Sequencer Logic

When Stage II shutdown velocity is achieved (as determined by the pilot), or propellants expended, +28 volts is removed from the \dot{S} disable logic, which enables S-dependent functions and starts the timer. At the same time, discrete No. 10, Stage II shutdown, is issued. At $\dot{S} + 2$ sec, discrettes 9 and 10 are disabled. Discrete No. 1 is disabled at $\dot{S} + 4$ sec. At $\dot{S} + 6$ sec, discrete No. 2, hold TM system on, is issued. At $\dot{S} + 9$ sec, discrettes 3 and 4 are issued, which are fire Stage II/III separation ordnance, and start Stage III hydraulics, respectively. At $\dot{S} + 12$ sec, discrete No. 5, start Stage III, is issued and \dot{S} -disable signal is sent to the timer, the timer is stopped, and the binaries reset.

The G-dependent functions are enabled by the removal of +28 volts from the G-disable logic by the guidance system or the pilot. At the same time, the timer is started, discrettes 4 and 5 are disabled, and discrete No. 11, turn-off command receivers, is issued. At $G + 2$ sec, discrete No. 9, spacecraft separation discrete to payload, is issued. At $G + 6$ sec, discrete No. 10, turn off tracking subsystem, is issued. Finally, at $G + 16$ sec, discrete No. 2 is disabled, turning off the TM system.

4. Signal Transfer Switch

The signal transfer switch that has been chosen for PIBOL is a 100-pole double-throw switch that is presently used in the instrumentation system of the standard Titan III launch vehicle. The switch (PD72S0078) was selected because it provides a sufficient number of switch pairs and contains latching circuitry to reduce the amount of hold-in power required.

The switch will be used to transfer the BIGS functions to the PIBOL system. Contact redundancy will be used as recommended in the reliability analysis (Chap. III.C.3).

The switch (PD72S0078) as presently procured, is rated for dry-circuit operation and current rating of the contacts is not controlled because of its use in the instrumentation system. For PIBOL the dry-circuit rating is not required, but contact rating must be controlled at one-half ampere minimum.

5. Stage III Rate Gyro System

The Stage III rate gyro system proposed for PIBOL is identical to the gyro systems presently used in Stage I and Stage II of the standard Titan III vehicle.

6. Stage I Lateral Acceleration Sensing System

The lateral acceleration sensing system (LASS) proposed for pilot monitoring purposes is identical to the PD96S0008 system presently used in Stage II of Titan III.

7. Equipment Installation

Three new components are required to be installed in Stage III; the signal selector switch, the rate gyro system, and the sequencer. The installation concept for these items is shown in Fig. 28. This concept is based on the present Titan III, Stage III, equipment truss configurations, and requires a minimum amount of added bracketry.

The lateral acceleration sensing system is installed on the Stage I oxidizer tank manhole cover. Installation on this cover assembly avoids complex truss assemblies required at other locations.

The weight added by the PIBOL unique equipment can be summarized as follows:

1) Stage III:

Rate Gyro System	15.0 lb
Signal Selector Switch	8.0 lb
Sequencer	8.0 lb
Bracketry	2.0 lb
Wiring	<u>4.0 lb</u>
Subtotal	37.0 lb

2) Stage I:

Lateral Acceleration Sensing System	10.0 lb
Bracketry	1.7 lb
Wiring	<u>0.9 lb</u>
Subtotal	12.6 lb

3) Stage II:

Wiring	<u>1.8 lb</u>
Grand Total	<u>51.4 lb</u>

8. Power Requirements

Power requirements for the added PIBOL components are as follows:

Component	Location	800 cps*** Sine Wave Power	28v dc Power
Stage III Rate Gyro System	Stage III	20 ⁺⁸ -0 watts	42 watts*
Stage I Accelerometer	Stage I	10 watts	None
Sequencer	Stage III	None	3 watts**

*Power required after gyro warmup.

**Does not include transient requirements for "mag-latching" relays.

***The additional 800 cps sinewave power requires modification of of the present A-C power source (static inverter) for PIBOL usage.

The dc power required by the components required for PIBOL can be provided by the existing batteries (for the X-20A mission). The existing static inverter does not provide sufficient power to supply the added ac power and requires modification.

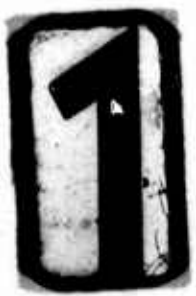

4.0
↓

New Location
Azusa Transponder

Existing Location
Azusa Transponder

PIBOL Sequencer Package

PIBOL Sequencer
Package

2

D

C

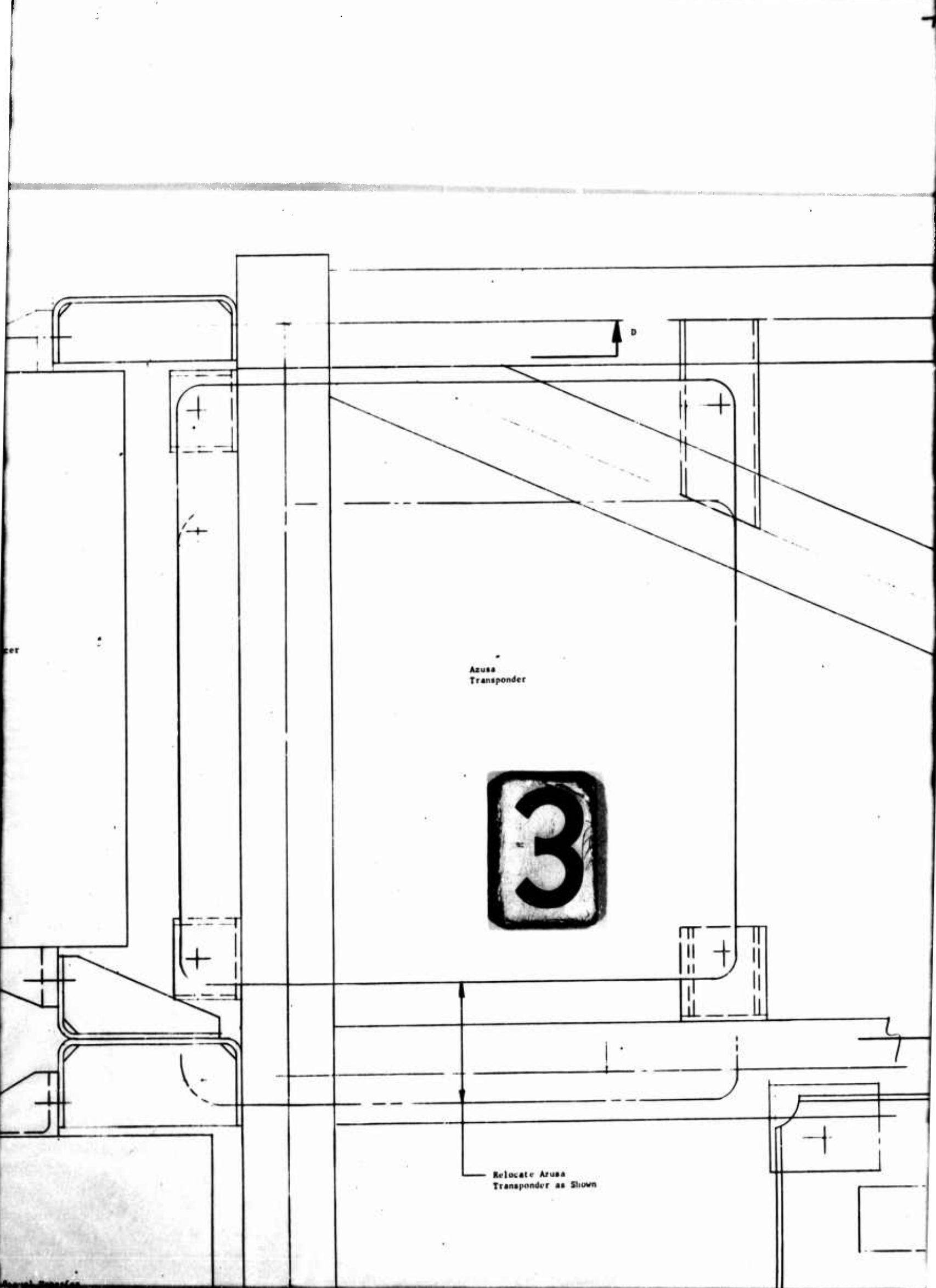

Azusa
Transponder

3

Relocate Azusa
Transponder as Shown

4

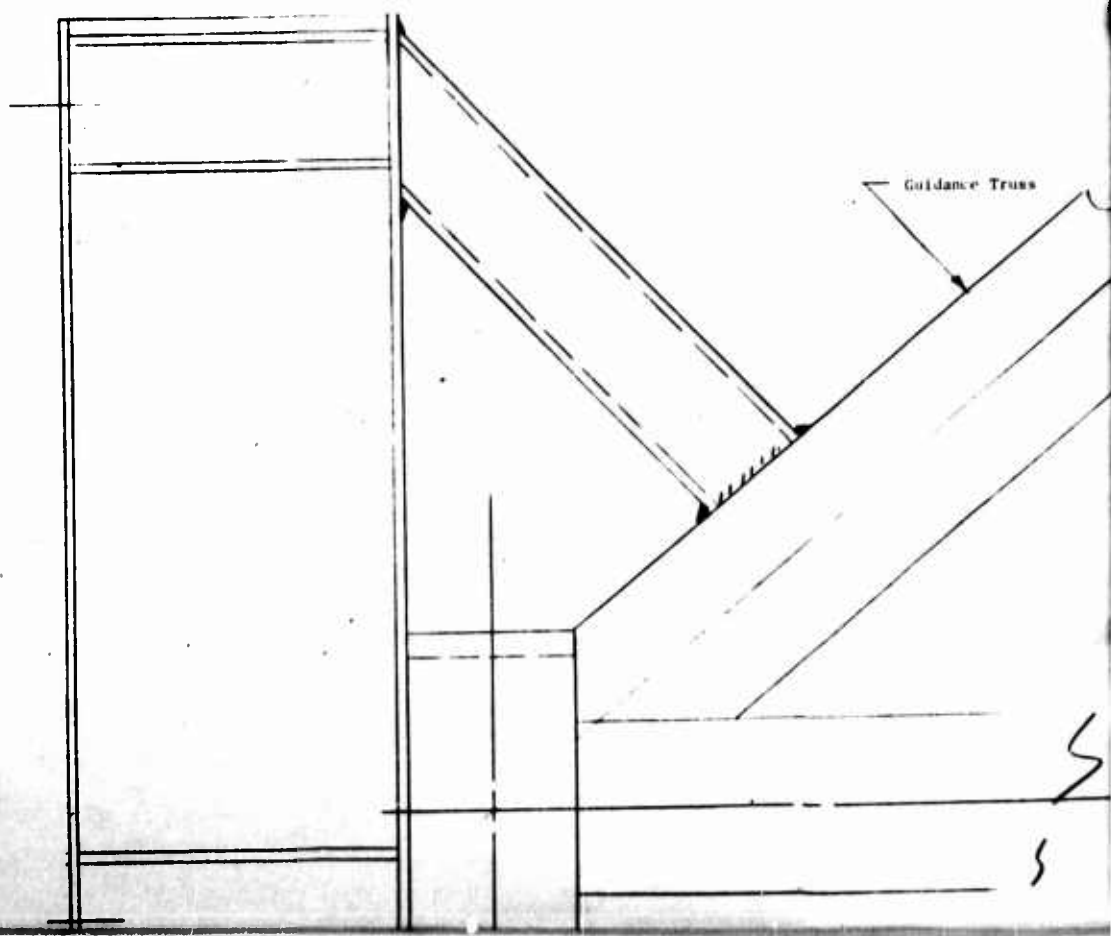

5

Target

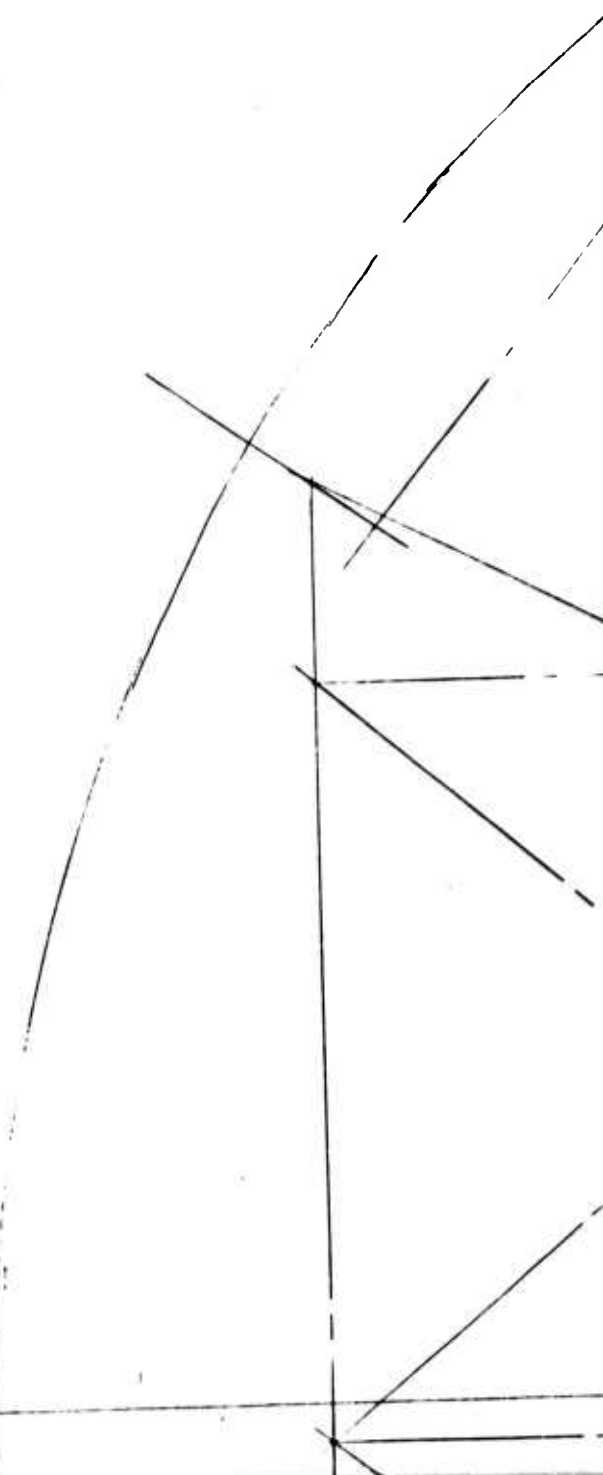

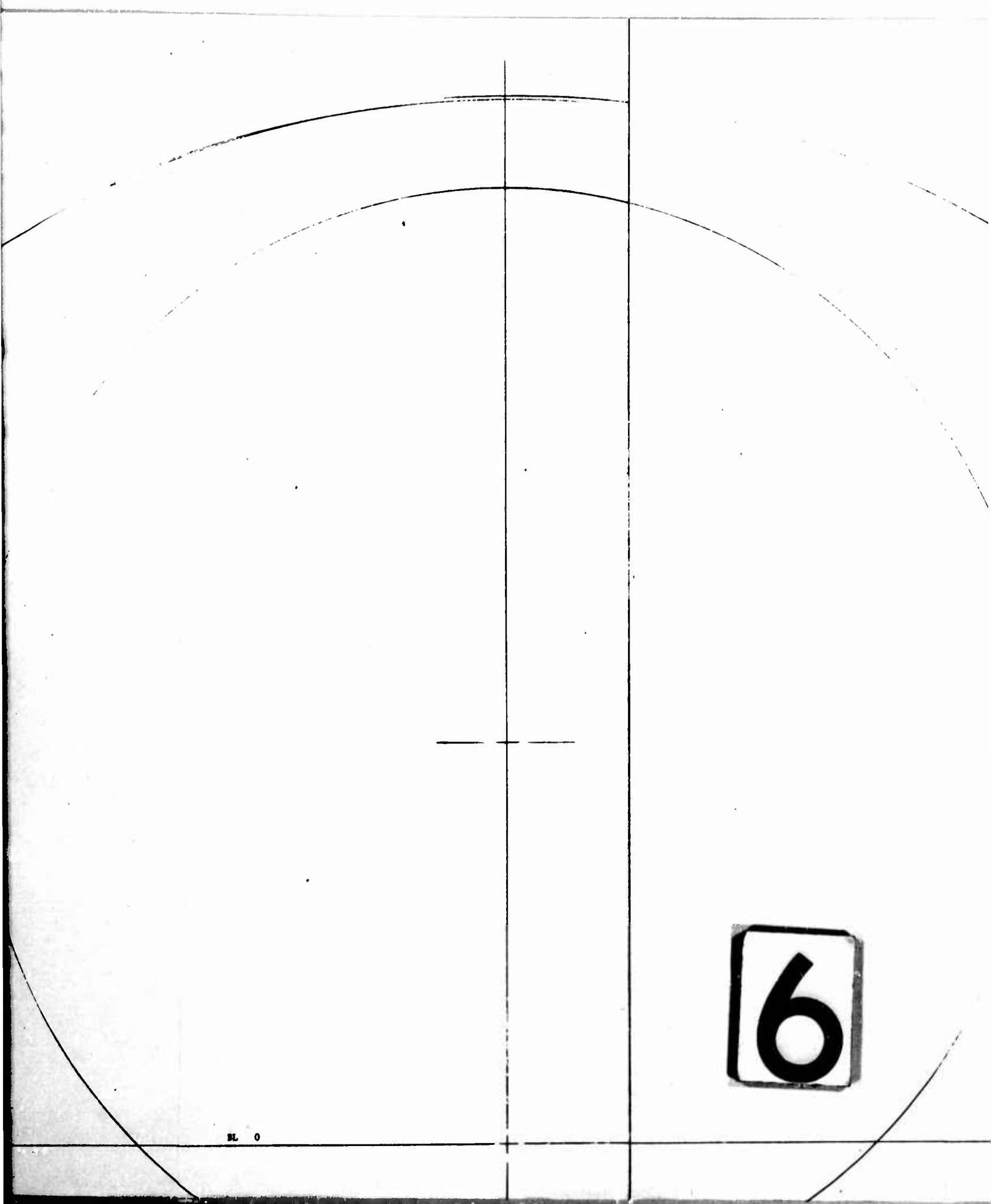

6

7

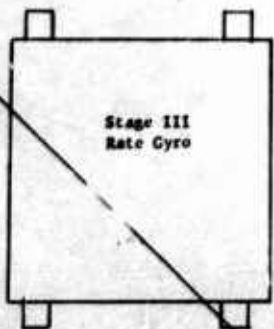

PCM Transmitter (Existing)
Relocate Approximately 4 in. Forward
of Existing Location

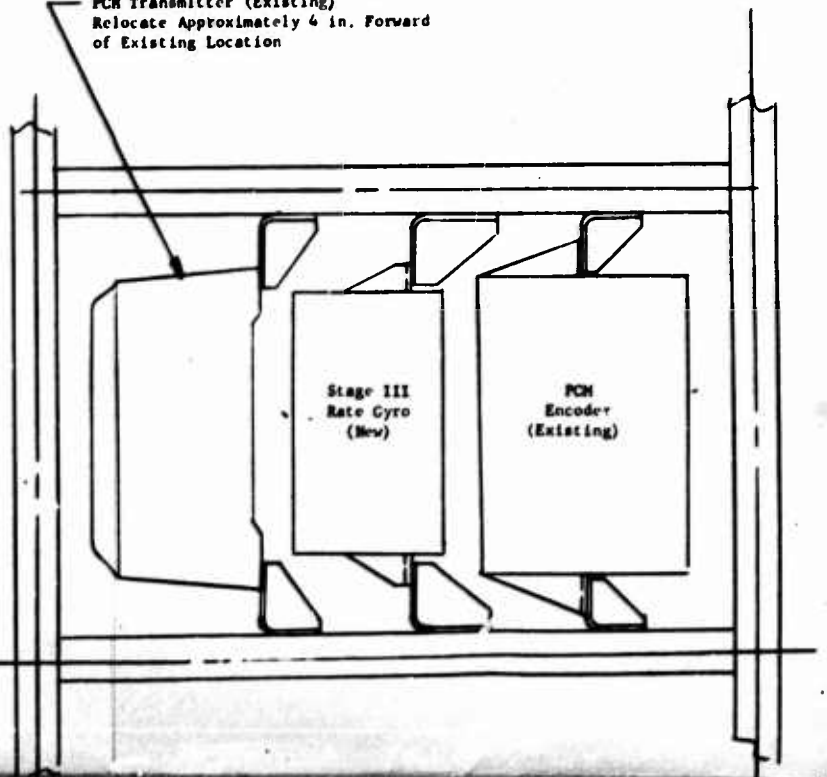

Signal Transfer
Switch

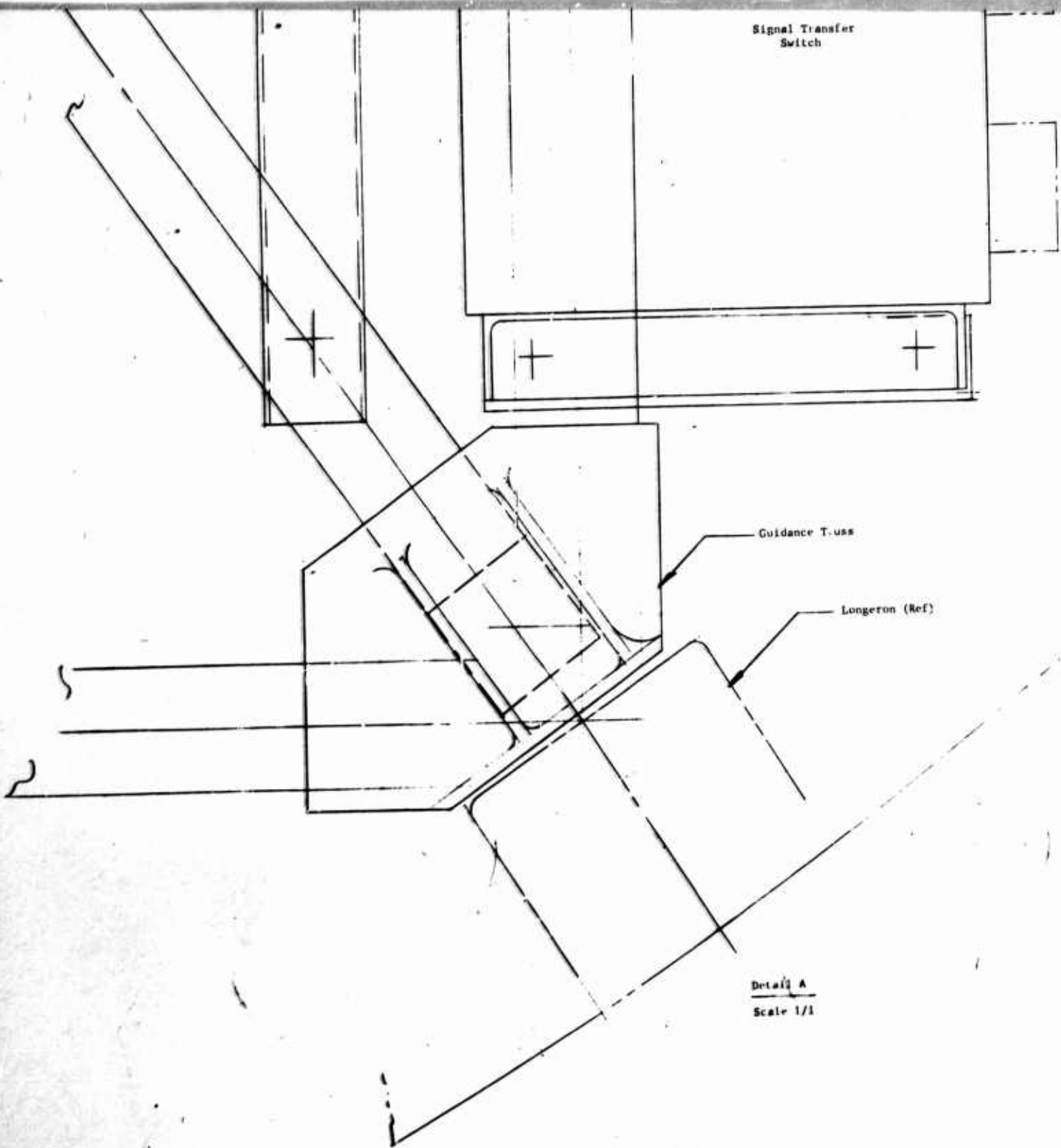

Detail A
Scale 1/1

8

Switch

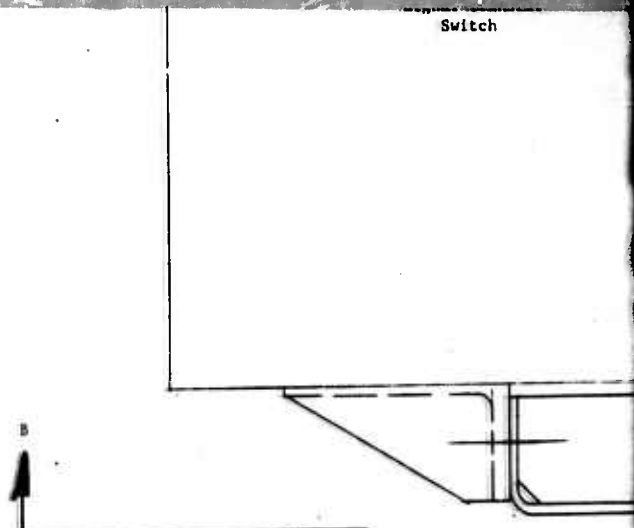

Access Door Contour (Ref)

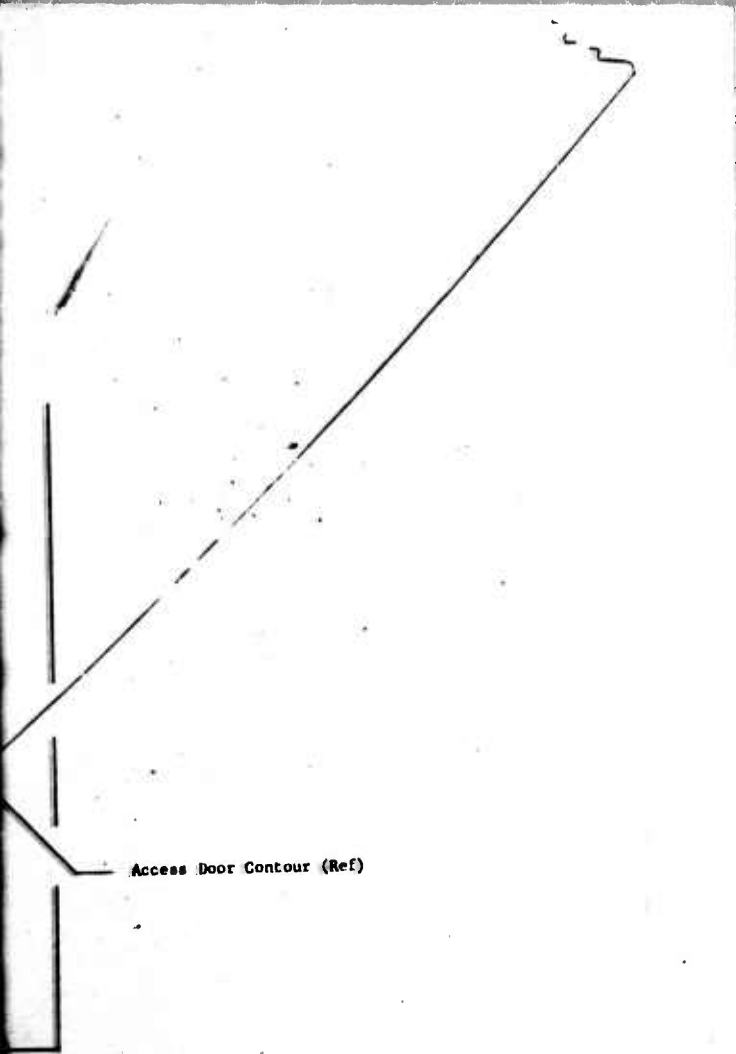

Signal Transfer Switch

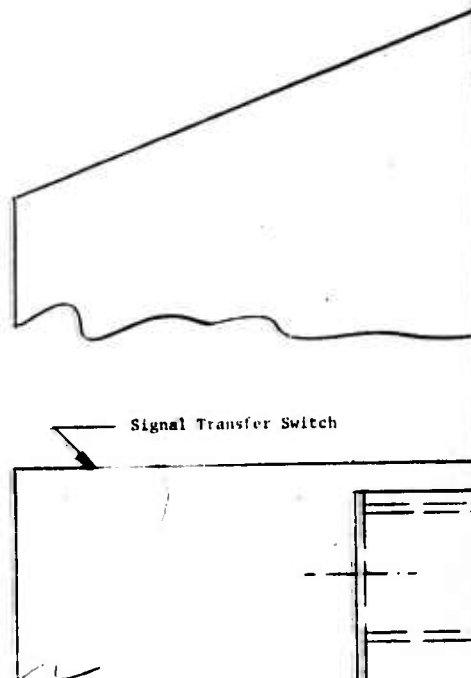

Sta 77
Payload
Interface



9

r

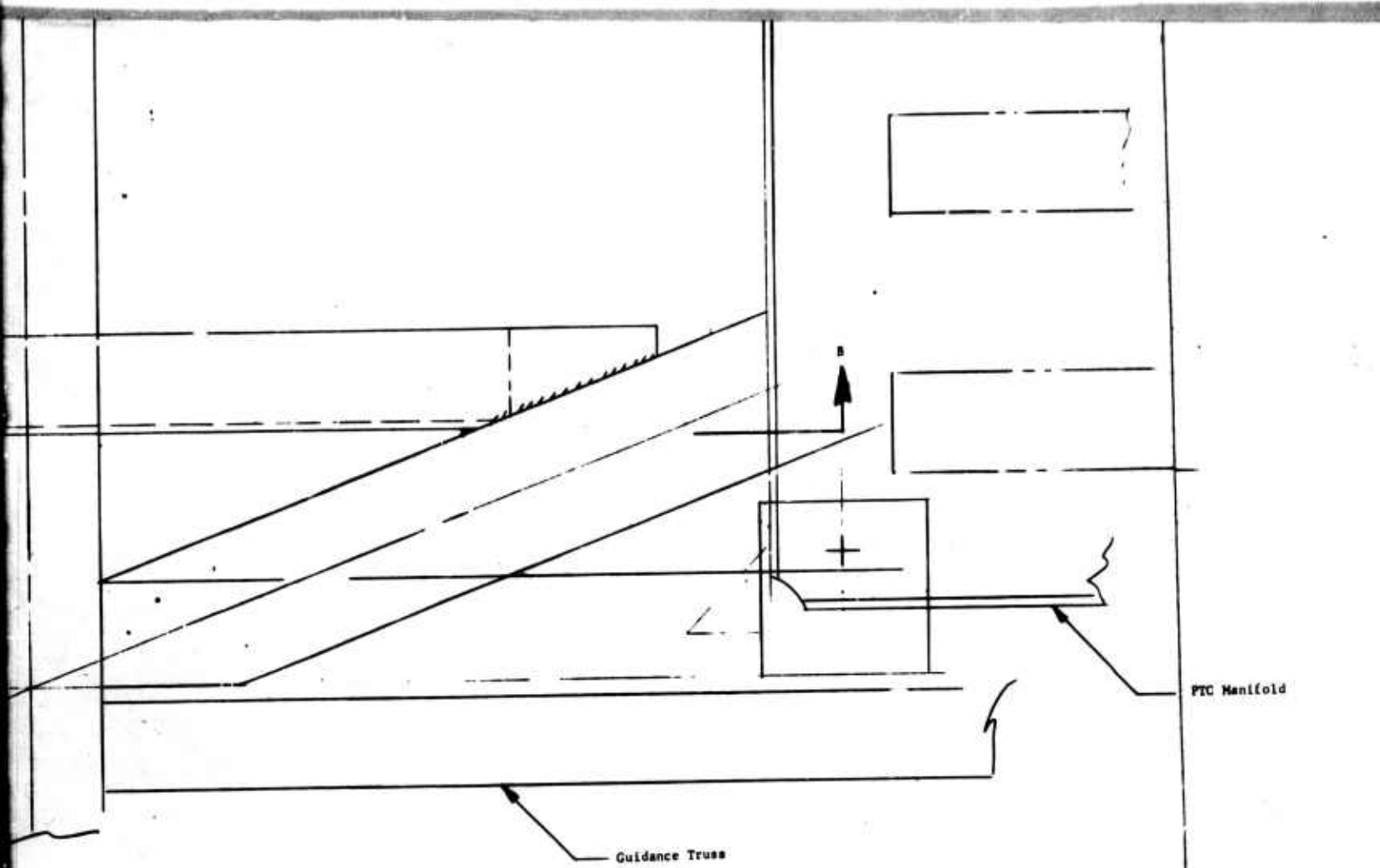

A-A

10

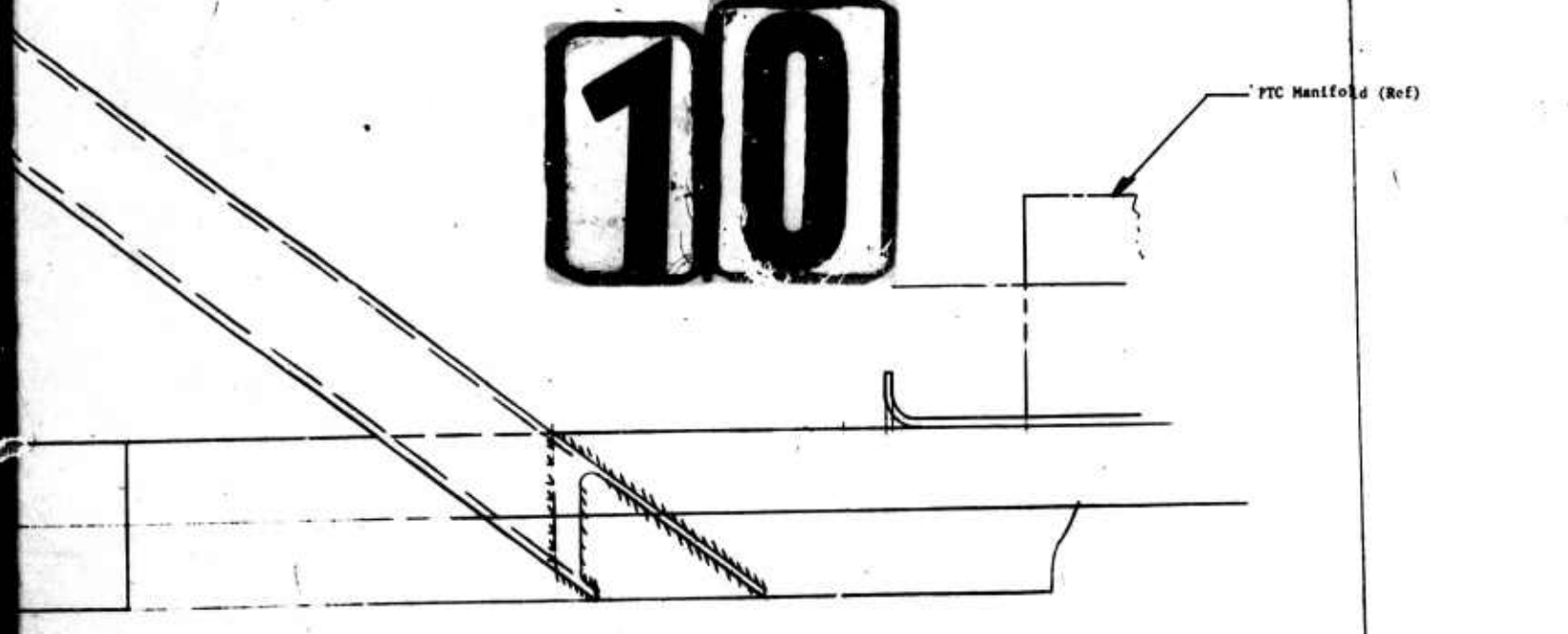

B-B

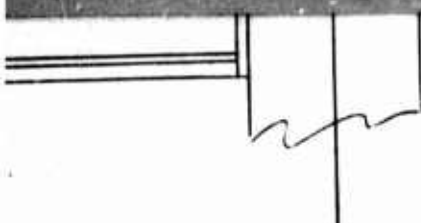

D-D

Azusa Transponder

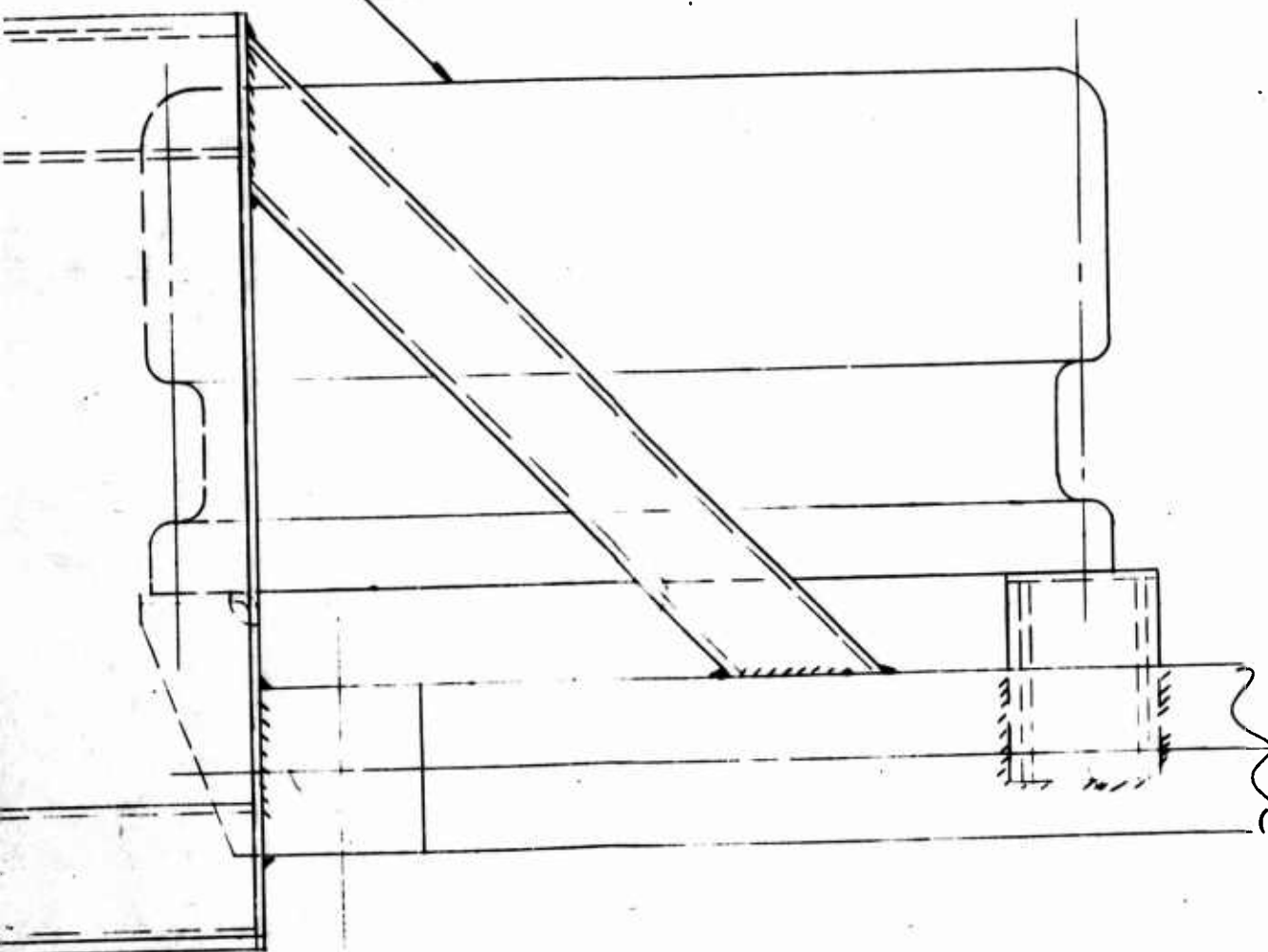

C-C



Guidance
Truss

ECU (Existing)

Signal
Transfer
Switch
(New)

PIDOL
Sequencer
Package
(New)

See Detail A



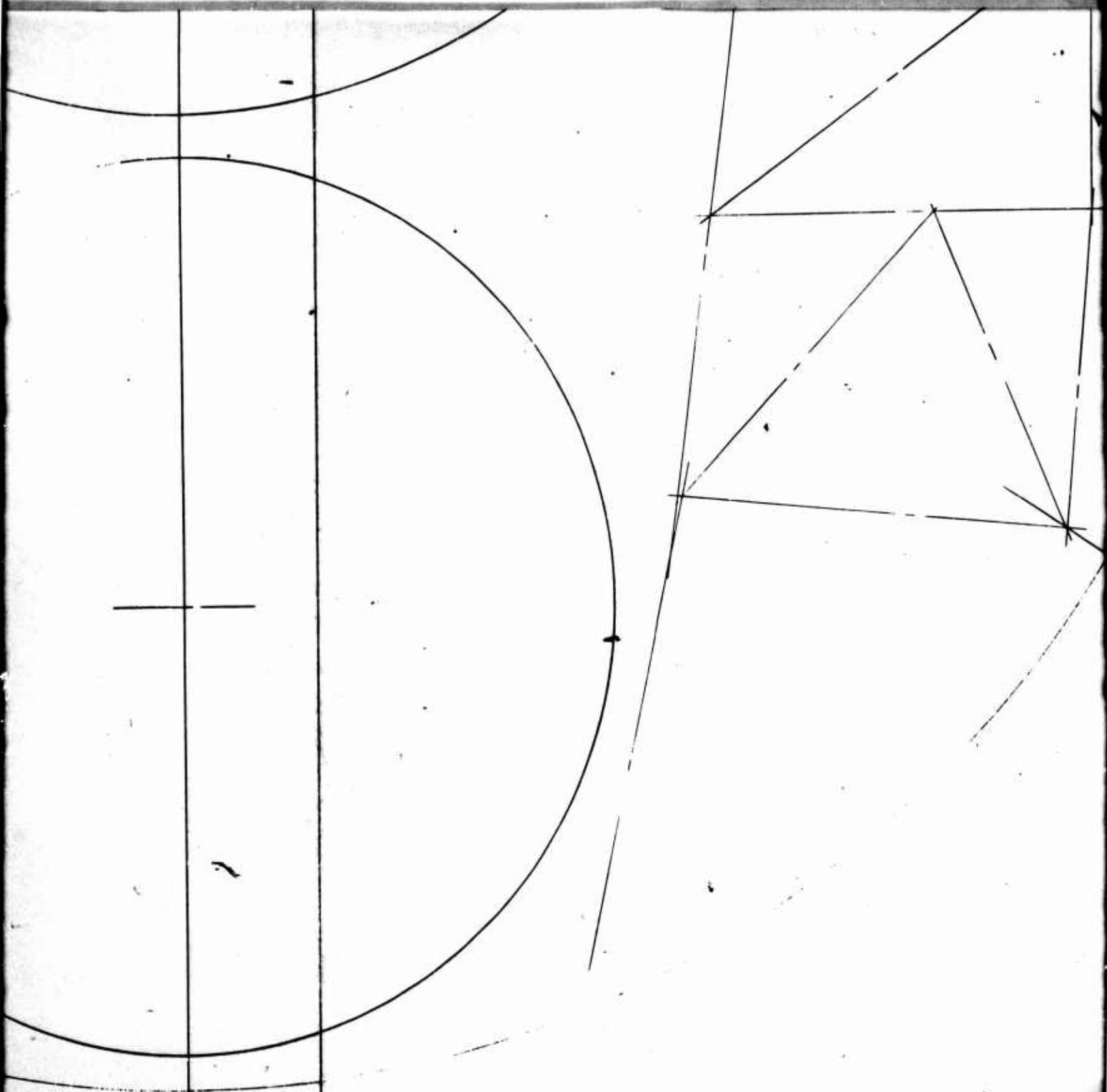

WL 60

View Looking Aft
Scale 1/4

13

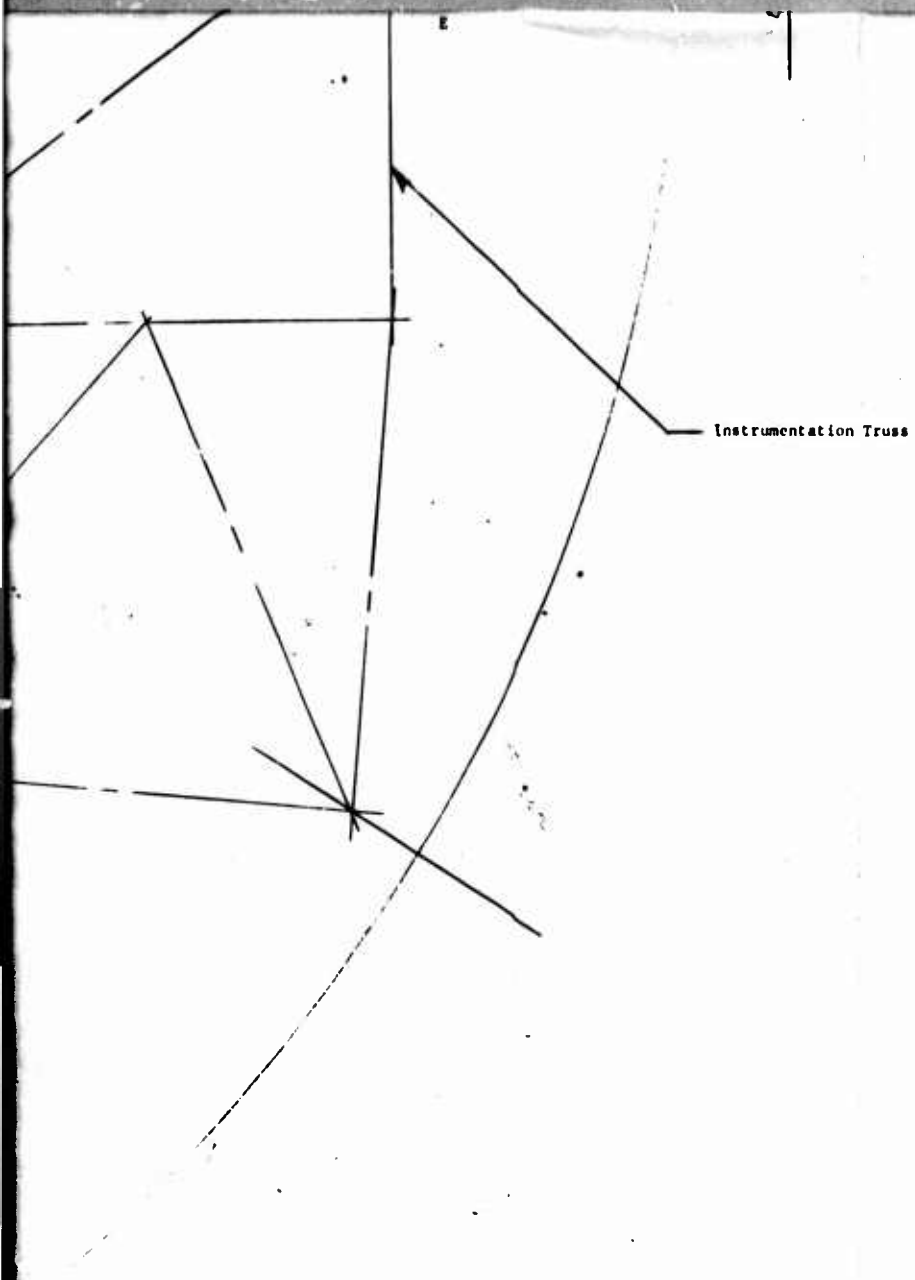

14

Fig. 28 Proposed PIBOL Equipment Locations

C. RELIABILITY ANALYSIS

Two of the many possible PIBOL configurations were considered in the reliability analysis: the Basic PIBOL system requiring displacement gyros (pitch, yaw, and roll) in Stage III; and a Broader PIBOL system using a single roll rate gyro in Stage III. Both systems required the addition of the vehicle sequencer, and different degrees of complexity of change to the flight controls adapter-programmer. Both of these systems are shown in detail in Appendix H. Conclusions of the reliability study are equally applicable to all PIBOL systems considered.

1. Mathematical Model Description

Conceptually, a Titan III equipped with PIBOL capability represents an application of standby redundancy where transfer is effected to a secondary system (PIBOL) by a sensor (pilot) on failure in a primary system (inertial guidance system).

A logic diagram describing the probability of obtaining mission success as a function of the several conditional probabilities associated with Titan III/PIBOL is depicted in Fig. 29.

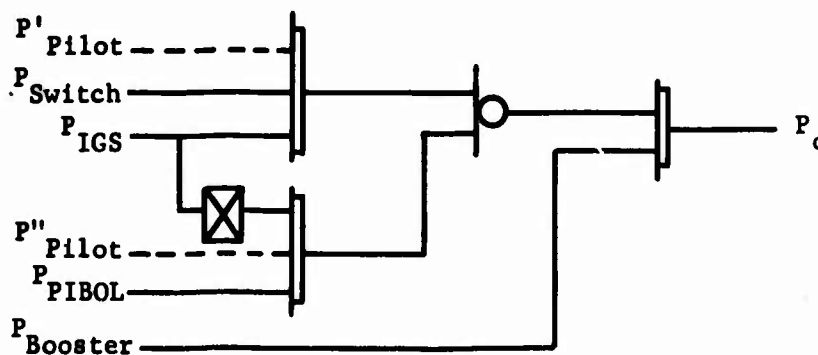
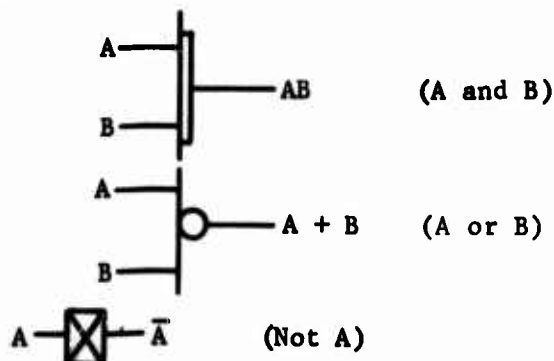

Fig. 29 Logic Diagram, Mission Success Probability

The notation is defined as follows:



The conditional probabilities are defined as follows:

- P_0 - Probability of mission success.
- P_{Switch} - Probability that equipment required to mechanize PIBOL will not detract from booster reliability, i.e., premature or unwarranted transfer of the mode selector switch will not occur.
- P_{IGS} - Probability that the inertial guidance system will provide correct attitude-error commands throughout flight.
- P_{PIBOL} - Probability of successful operation of equipment specifically required to mechanize PIBOL including the probability that the mode selector switch will function when required.
- P_{Booster} - Probability that all subsystems in the basic vehicle except for guidance functions will yield mission success. Some failure modes in the inertial guidance system are included with P_{Booster} since they are not accommodated in PIBOL, i.e., all IGS discrettes turn on simultaneously.

A complete PIBOL math model must include two additional probabilities, each relating to the pilot. The pilot must not initiate an unwarranted transfer to the PIBOL mode (P'_{PILOT}). The pilot must recognize and react to an IGS failure and must perform satisfactorily upon transfer to the PIBOL mode (P''_{PILOT}). In each instance a probability can be assigned to the pilot's performance with a strong effect on overall mission success. In this study the effect of the pilot on mission success has been omitted and the results are based solely on hardware considerations.

From the logic diagram, a mathematical model representing the probability of a successful mission with PIBOL backup capability can be represented as the summation of conditional probabilities (Eq [4]). This equation is equally valid for Basic and Broader PIBOL.

$$P_0 = P_{\text{Booster}} \left[P_{\text{IGS}} P_{\text{Switch}} + P_{\text{PIBOL}} (1 - P_{\text{IGS}}) \right]. \quad [4]$$

Similarly, the probability of mission success of the basic Titan III vehicle without PIBOL is described by simplifying Eq [4].

$$P_0 = P_{\text{Booster}} P_{\text{IGS}} \quad [5]$$

For the purpose of comparison, Eq [4] and Eq [5] are combined in Eq [6] to obtain the minimum required P_{PIBOL} for given values of P_{IGS} and P_{Switch} .

$$1 > P_{\text{PIBOL}} > \frac{P_{\text{IGS}} (1 - P_{\text{Switch}})}{(1 - P_{\text{IGS}})} \quad [6]$$

Unless Eq [6] is satisfied, the addition of PIBOL capability to the Titan III vehicle will degrade rather than improve the probability of mission success. Equation 6 has been plotted in Fig. 30 for several values of P_{Switch} and P_{IGS} . For given values of P_{Switch} and P_{IGS} the resulting value of P_{PIBOL} represents an absolute minimum requirement. Greater values of P_{PIBOL} will result in a net reliability improvement while lesser values will degrade reliability below that obtainable with the basic Titan III vehicle.

The probabilities (P_{IGS} , P_{Switch} , and P_{PIBOL}) described in Eq [4] are determined as follows for each component,

$$P = 1 - K_i t_i \sum \lambda_i \quad [7]$$

where

λ_i = The generic failure rate for the i_{th} component,

K_i = An application factor for the i_{th} component that describes the environment for the component,

t_i = The time interval over which the i_{th} component functions.

For the convenience of computation, booster flight is divided into solid boost, first stage flight, second stage flight, and Stage III flight. Stage III flight is further subdivided into coast and powered flight subphases. Application factors (K_i) and elapsed time (t_i) for each phase are listed in Table 8.

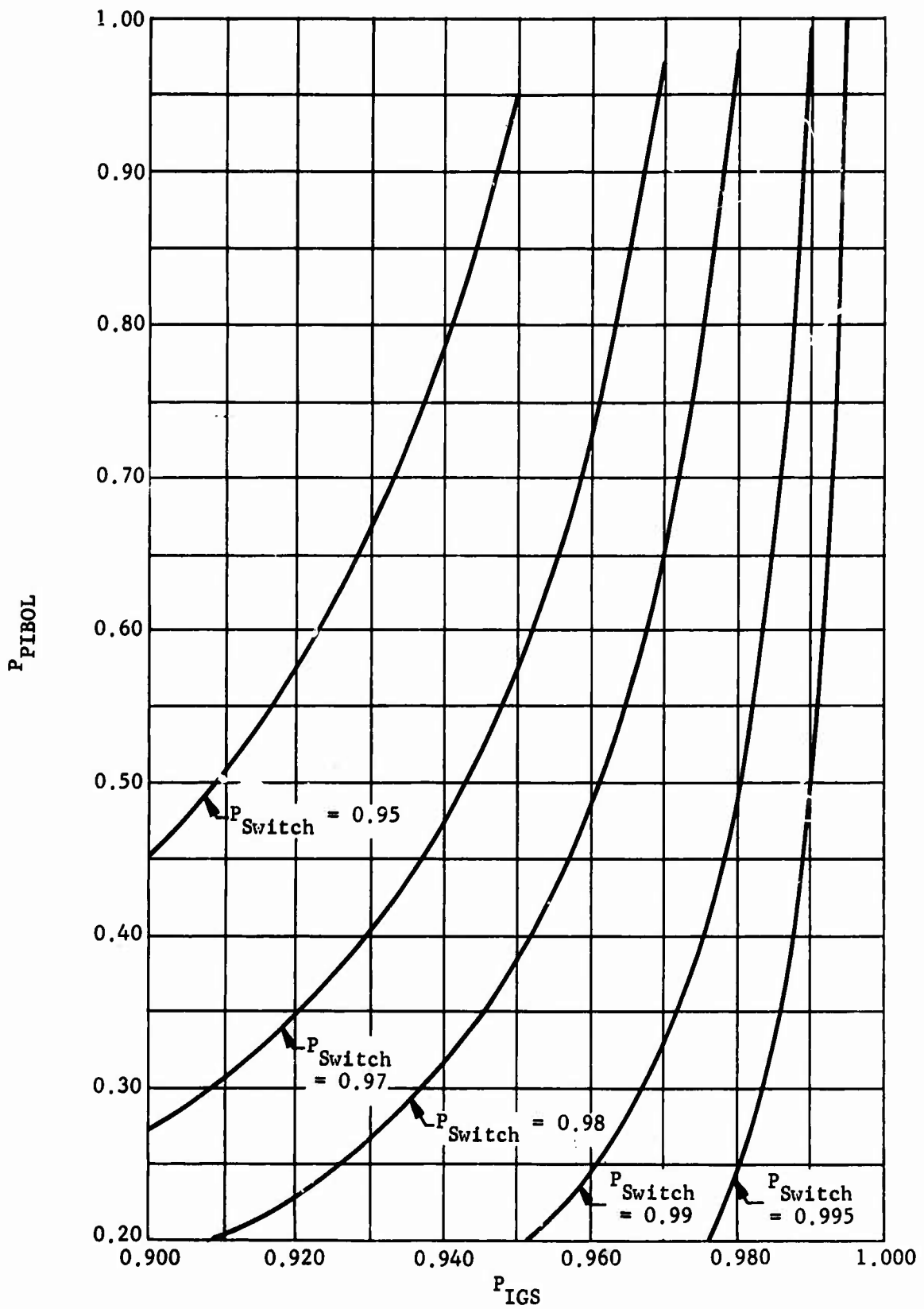

Fig. 30 Minimum Required P_{PIBOL} for Given Values of P_{IGS} and P_{Switch}

Table 8 Application Factors K_1 and Elapsed Time t_1

Mission Phase	Time (hr)	K_1 Applicable To		$K_1 t_1$ Applicable To	
		P_{Booster} P_{Switch} P_{PIBOL}	P_{IGS}	P_{Booster} P_{Switch} P_{PIBOL}	P_{IGS}
Solid Boost Flight	0.0292	150	30	4.380	0.876
Stage I Flight	0.0414	20	15	0.828	0.721
Stage II Flight	0.0584	20	15	1.168	0.876
Stage III - Power On	0.1303 max	50	15	6.515 max	1.955 max
Stage III - Coast	6.5167 max	3	1.5	19.550 max	9.770 max

Failure rates or probabilities for the several equipments considered in this analysis are listed in Table 9 and were either contained in or inferred from the accompanying references.

The failure rates for equipment required to mechanize both Basic and Broader PIBOL (λ_8) are listed in Table 10.

The failure rates for equipment required to transfer to the PIBOL mode (λ_9) are listed in Table 11.

In terms of the constants listed in Table 9, a set of equations may be written relating success probabilities and failure rates. Equations [8] thru [11] form the basis for the reliability calculations presented in Appendix G.

$$P_{\text{Booster}} = P_1 P_2 P_3 \left[1 - K_6 t_6 \lambda_6 \right] \left[1 - K_7 t_7 \lambda_7 \right] \left[1 - K_4 t_4 \lambda_4 \right], \quad [8]$$

$$P_{\text{IGS}} = \left[1 - K_5 t_5 \lambda_5 \right], \quad [9]$$

$$P_{\text{Switch}} = \left[1 - K_9 t_9 \lambda_9 \right], \quad [10]$$

$$P_{\text{PIBOL}} = \left[1 - K_8 t_8 \lambda_8 \right], \quad [11]$$

2. PIBOL Reliability

The probability of a successful mission (P_0) as a function of Stage III coast and powered flight time is depicted as a family of curves in Fig. 31. Data are included for two modes of operation, with and without PIBOL backup. The curves encompass the full range of Stage III capability in that Stage III powered flight and coast time are treated as variables and extend to 500 sec and 6 hr, respectively. A point solution for the Dyna-Soar mission involves 18 sec of Stage III powered flight with zero coast time and would not be applicable to other PIBOL-equipped, manned vehicles.

For a given powered flight/coast time, the difference between mission success probabilities with and without PIBOL is a measure of available reliability improvement. (Additional missions completed = "difference" $\times 10^3$.) On this basis, flights-saved-per-1000 flights is plotted in Fig. 32 as a function of Stage III powered flight and burn time with the result that the maximum attainable improvement with PIBOL for a mission approaching the maximum Titan III capability (i.e., 6-hr coast, 500-sec Stage III burn time) is the difference between $P_0 = 0.8584$ and $P_0 = 0.8410$ or 17.4 vehicles per 1000. For the Dyna-Soar mission the reliability improvement is the difference between $P_0 = 0.9125$ and $P_0 = 0.9091$, or 3.4 vehicles per 1000.

Table 9 Failure Rates or Probabilities

Subsystem	Failure Rate (λ : FPM) Probability (P)	Source	Assignment
Stage I and Stage II Engines	$P_1 = 0.970$	*	P Booster
Solid Rocket Motors	$P_2 = 0.980$	*	P Booster
Transtage Engines	$\lambda_4 = 384$	*	P Booster
Inertial Guidance System			
Steering Signals	$\lambda_5 = 1300$	**	PIGS
Discrete Commands	$\lambda_6 = 122$	**	P Booster
Booster Components (Martin)			
Liftoff thru Stage II S/D	$P_3 = 0.963$	†	P Booster
Transtage Flight and Coast	$\lambda_7 = 1728$	†	P Booster
PIBOL Mechanization Components (Basic)	$\lambda_8 = 110.4$	Table 8	P PIBOL (Basic)
PIBOL Mechanization Components (Broader)	$\lambda_8 = 82.1$	Table 8	P PIBOL (Broader)
Mode Selector Components (Basic)	$\lambda_9 = 1.298$	Table 9	P Switch (Basic)
Mode Selector Components (Broader)	$\lambda_9 = 2.227$	Table 9	P Switch (Broader)

*Program 624A Reliability and Quality Assurance Program Requirements. SSD Exhibit 62-117, 1 November 1962, and Addendum dated 30 November 1962. (Confidential)

**Inertial Guidance System, Program 624A - Titan III Airborne IGS Failure Mode Analysis Report. 63 - RT000 - V3345, III-A-8, AC Spark Plug, 22 April 1963. (Secret)

†Reliability Analysis Report - 6-4A, SSD-CR-63-89 Rev 2, March 1964. (Confidential)

Table 10 Equipment to Mechanize Basic and Broader PIBOL

Item	λ (PPM)	Basic PIBOL		Broader PIBOL	
		Qty	λ Total (PPM)	Qty	λ Total (PPM)
Resistor	0.030	312	9.360	234	7.020
Capacitor	0.013	105	1.465	70	0.910
Transistor	0.250	99	24.750	76	19.000
Diodes, Signal	0.200	161	32.200	145	29.000
Diode, Zener	0.250	9	2.250	2	0.500
Diode, Double Base	0.250	1	0.250	1	0.250
Transformer	0.300	5	1.500		
Relay, Magnetic Latching	0.500	17	8.500	17	8.500
Relay, Signal	0.250	3	0.750	2	0.500
Switch, Thermo	0.060	2	0.120		
Inductor	0.200	1	0.200		
Accelerometer	2.800	1	2.800	1	2.800
Gyroscope	8.000	3	24.000	1	8.000
Mode Selector Switch	--	1	1.400	1	4.300
Connector Pin-Pairs*	0.024 (shorted)	17	0.408	17	0.408
	0.036 (open)	19	0.684	25	0.900
Total (λ 3)			110.437		82.088

*A connector pin-pair is defined as a wire segment terminated at both ends in connector pins.

Table 11 Equipment to Transfer to PIBOL Mode (λ 9)

Item	λ (PPM)	Basic PIBOL		Broader PIBOL	
		Qty	λ Total (PPM)	Qty	λ Total (PPM)
Mode Selector Switch	—	1	0.350	1	1.075
Connector Pin-Pairs*	0.024 (shorted)	17	0.408	24	0.576
	0.036 (open)	15	0.540	16	0.576
Total (λ 9)			1.298		2.227

*A connector pin-pair is defined as a wire segment terminated at both ends in connector pins.

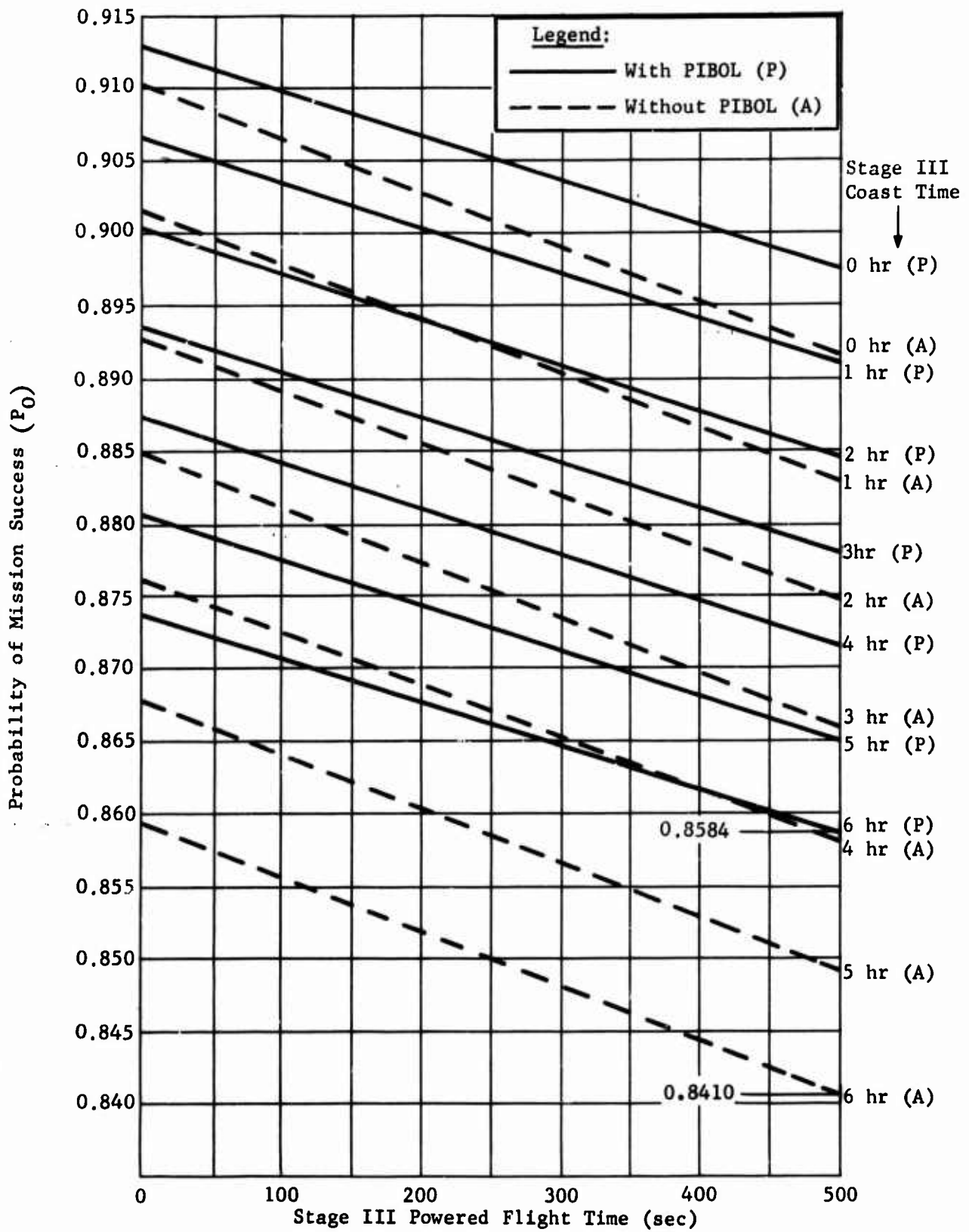

Fig. 31 Mission Success with and without PIBOL

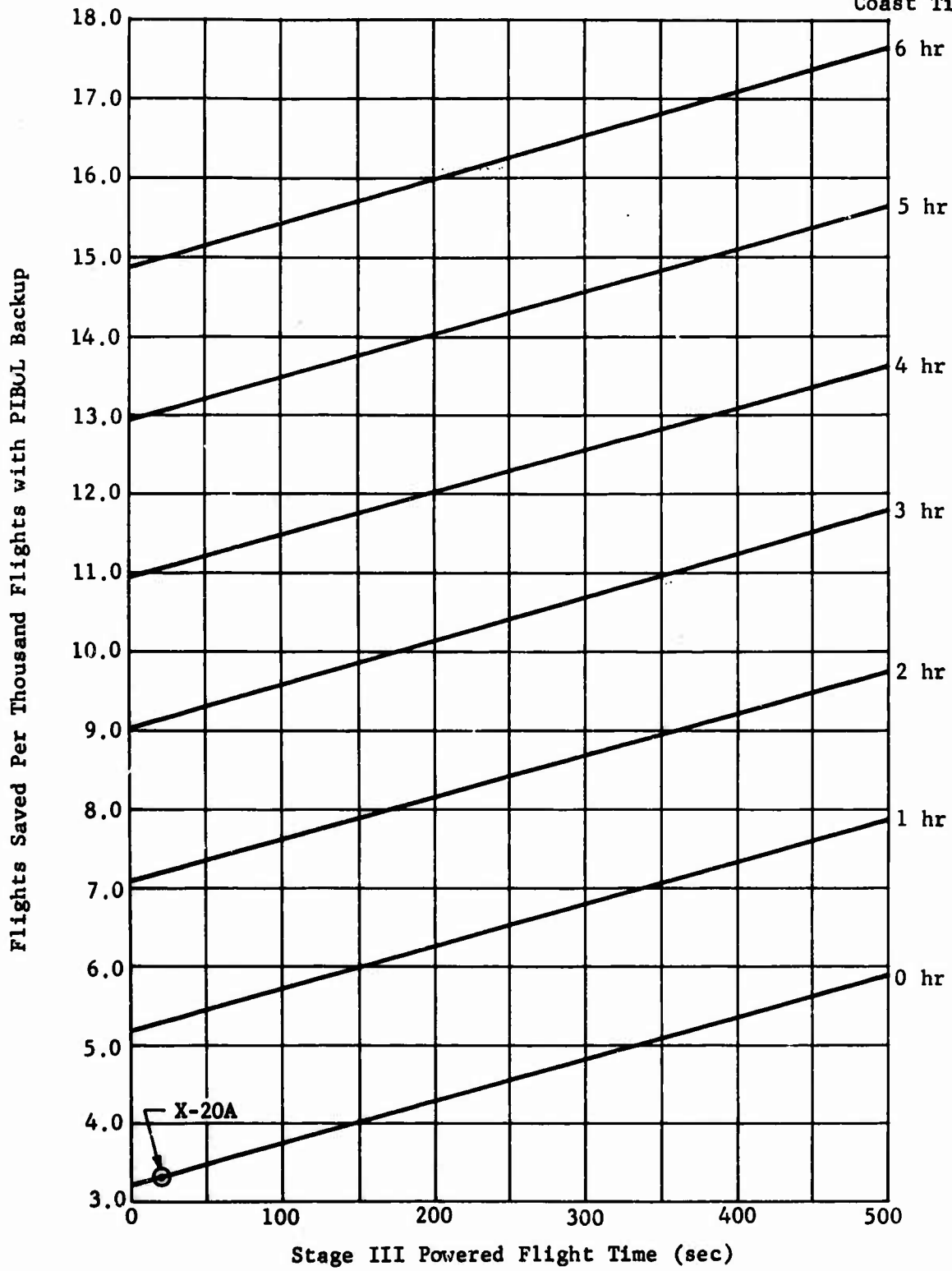

Fig. 32 Flights-Saved-Per-Thousand-Flights with PIBOL Backup vs Stage III Powered Flight/Coast Time

Conclusions to be drawn from Fig. 31 and 32 are equally applicable to both the Basic and Broader PIBOL mechanizations. Calculations indicate that the Basic PIBOL mechanization yields a greater P_0 ; but only by 5 to 15 parts/million. On the basis of flights-saved-per-1000 flights, the difference is not discernible and each mechanization is equally effective in minimizing mission losses resulting from guidance-system steering-command failures. It should be noted that with this concept of a redundant guidance system, i.e., the pilot, it is only possible to save 17.6 vehicles per 1000 with a perfect PIBOL system. Thus, further increase in PIBOL reliability (if possible) would bring a negligible increase in mission success.

3. Failure Mode Analysis and Redundancy Recommendations

From the mathematical model and Fig. 30, it is evident that mission success probability, P_0 , with PIBOL backup is a strong function of the factor, P_{Switch} , and to a lesser extent, P_{PIBOL} . P_{Switch} has a direct compromising effect on otherwise successful flights in the automatic mode (~98%) while the compensating effect of P_{PIBOL} is limited to inflight failures of the inertial guidance system (~2%). The failure mode with greatest impact on mission success is, therefore, one in which an automatic flight is aborted by failure in the mode selector switch or associated wiring. These failures include unwarranted transfer from the automatic mode to the PIBOL mode as well as interruptions of signal flow across the IGS/Flight Control System interface. In either event, the standby redundancy option must be exercised and the pilot is committed to complete the mission in the PIBOL mode, if possible. Consequently, the design of an optimum PIBOL system requires a maximum of isolation between components in the automatic and PIBOL mechanizations.

Both the Basic and Broader mechanizations use a similar switch to obtain mode transfer; the only difference being the requirement for additional contact sets in the broader system to accommodate the Stage III roll-rate gyro and gain changes in the adapter-programmer. To inhibit premature mode transfer and interruptions in signal flow, switch contacts may be made redundant with the following result:

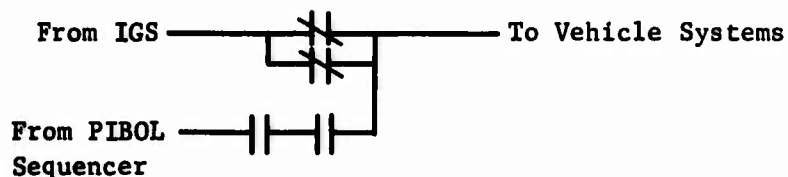

Both switch contacts from the inertial guidance system must fail open or both switch contacts from the PIBOL sequence must fail shorted to result in a system failure. A maximum of three single-pole-double-throw relays is required for each switch function. The resulting improvement in switch reliability is of the form:

$$P_{\text{Switch Contacts (Redundant)}} = \left[1 - \left(1 - P_{\text{Switch Contacts}} \right)^2 \right].$$

Under the worst condition, $P_{\text{Switch Contacts (Redundant)}} \gg 0.999999$, and is eliminated as a contributing factor to automatic flight-mode unreliability. P_{PIBOL} , however, is affected to a slight extent by the addition of a redundant switch. The failure rate (λ_8) increases from 110.4 to 113.1 ppm in the basic system and from 82.1 to 90.7 ppm in the broader system; nevertheless, a net improvement in P_0 is realized with redundant switch contacts in either mechanization. Cordage failures, shorts and opens, between the mode selector switch and autopilot also contribute adversely to P_{Switch} . Shorts between adjacent pin-pairs can be minimized in the detailed design of PIBOL equipment through connector selection, pin/circuit assignments and cable routing. Open connector pin-pairs can be circumvented by the addition of parallel signal paths with a reliability improvement comparable to that obtainable with redundant switch contacts.

D. PIBOL GROUND CHECKOUT REQUIREMENTS

Ground test requirements were investigated for PIBOL with the following major objectives:

- 1) Maximize the extent that performance can be verified;
- 2) The design should permit rapid and positive recognition of equipment malfunction or marginal performance;
- 3) The design should use, to the greatest extent possible, existing tools and checkout equipment.

1. Existing Titan III OGE (Operating Ground Equipment)

Titan III OGE end items presently used for vehicle checkout and launch, which can be utilized for PIBOL checkout are described as follows:

- 1) Data transmission set, which provides transmission of control and monitor signals between the Control Center and the AGE Van for SSLV OGE, ground instrumentation equipment, and payload aerospace ground equipment (AGE);
- 2) Control monitor group (CMG), which contains equipment necessary to perform the following functions:
 - a) Control a time-based countdown for the complete vehicle including payload,
 - b) Automatic control and monitoring of launch and prelaunch monitor functions,
 - c) Provide hold, kill, and shutdown capability during the launch sequence,
 - d) Reset capability,
 - e) Provide capability for patching input and output signals,
 - f) Provide input simulation of signals and control of simulator-testers during the combined systems test,
 - g) Drive countdown readout indicators; the CMG sequences the countdown functions on a time basis, and all automatically commanded functions originate within the CMG and are distributed to the appropriate subsystem;
- 3) Data recording set (DRS), which provides a permanent record of the OGE and booster events sequencing during readiness, launch countdown, vehicle checkout, and combined system testing. The data are stored on magnetic tape for processing in an IBM 7090 digital computer and are also printed to provide an immediate look capability for holds, kills, combined systems test evaluation, and to aid in malfunction analysis;
- 4) Vehicle checkout set (VECOS), which provides a means for checking the vehicle flight control system, hydraulics, malfunction detection system, and low level sensors. The VECOS is controlled by a tape programmer.

2. PIBOL Checkout and Launch Requirements

The recommended PIBOL system defined in Chap. III.B differs from the standard Titan III vehicle as follows:

- 1) The vehicle sequencer is completely new for PIBOL and must be tested to assure that it initiates properly, provides the proper time base, provides the proper discrete signals to the vehicle, and that its accelerometer functions properly. It also must be initiated at liftoff;
- 2) The Stage III rate gyro system (only roll is used) is identical to the rate systems already in use in Titan III. It requires additional checkout functions identical to those provided for the existing gyros, such as spin-motor-rotation-detection (SMRD), gyro heater checks, gain and null tests;
- 3) The adapter-programmer modifications are mainly changes in gain and signal routing. This requires additional gain tests, similar to the tests presently performed by the OGE;
- 4) The signal selector switch operation and all of the switching, that is required to operate for PIBOL must be verified;
- 5) The lateral accelerometer added to Stage I (for pilot's display) must be verified for proper operation.

3. PIBOL Test Methods

The PIBOL system can be adequately tested using the existing OGE. Changes to the OGE to accept PIBOL are limited to interconnections between racks and vehicle umbilicals, VECOS tape programmer changes, and patching changes to equipment that uses patchboards for signal routing. A summary of the tests is shown in Table 12. A summary of the impact on OGE is shown in Table 13.

4. Other PIBOL Systems

PIBOL systems other than the recommended system were also evaluated with respect to ground test requirements. Both the Basic system (with displacement gyros) and the Broader system were examined. Checkout and launch requirements and test methods are

identical to those required for the recommended PIBOL system, except for details associated with the displacement gyros or the stimulus levels that would be used in VECOS static gain tests.

The overall effect on the OGE for the Basic PIBOL system using displacement gyros is identical to that shown in Table 13, except that the displacement gyro functions replace those called out for the Stage III rate gyro.

Broader PIBOL would affect the OGE in the same manner as the recommended Basic PIBOL (Table 13), provided that the airborne system could meet the PIBOL requirements.

Table 12 PIBOL Ground Checkout Methods

Associated PIBOL Equipment	Tests Required		OGE Affected	Change Required
	Description	Type*		
Vehicle Sequencer	Verify discrete outputs (11) from timer (during combined systems test)	M	DRS	Add wires from umbilical to existing spare channels on DRS. Add wires from umbilical and patch on CMG patchboard. Add wires from umbilical and modify tape program.
	Reset sequencer timer before liftoff	C	CMG	
	Verify sequencer timer is reset before liftoff	M	CMG	
	Start PIBOL timer at liftoff	C	CMG	
	Exercise sequencer accelerometer	C,M	VECOS	
Stage III Rate Gyro System (Roll only)	Verify gyro spin motors operating	M	CMG	Add wires from umbilical and patch on CMG patchboard.
		M	VECOS	Umbilical terminations and tape program change.
		M	DRS	Umbilical termination to existing spare channel on DRS.
	Verify gyro heater operating	M	CMG	Same as for spin motors above.
		M	VECOS	
		M	DRS	
	Verify gyro null in limits	M	VECOS	Umbilical termination and tape program change.
	Verify static gain of roll gyro channel	C,M	VECOS	Umbilical termination and tape program change.
Adapter-Programmer Modifications	Verify channel gains in approximate integrator channels	C,M	VECOS	Tape program change.
	Verify channel gains in Stage 0 roll-rate channels	C,M	VECOS	Tape program change.
Standard Titan III FCS/PIBOL switching (including signal selector switch)	Verify Auto/PIBOL Relays in Auto	M	CMG	Umbilical termination and patch on CMG patchboard.
		M	DRS	Umbilical termination and spare DRS channel. (This function also verified by successful completion of other tests.)
Lateral accelerometer (for display)	Verify accelerometer scale factor and null	C,M	VECOS	Umbilical termination and tape programmer change. (Also may be verified by pilot.)
*C - Command from OGE. M - Monitored by OGE.				

SSD-CR-64-32

Table 13 Summary of PIBOL Impact on OGE

OGE End Item	PIBOL Effect
Control Monitor Group (CMG)	a) Add functions to readiness "Go": 1) Stage III Rate Gyro SMRD, 2) Stage III Rate Gyro Heater, 3) Auto - PIBOL Switches in Auto; b) Add - Sequencer Timer Reset Capability at T-5 sec; c) Add - Sequencer Timer Reset Verification at T-0.5 sec; d) Add - PIBOL Sequencer Timer Start at T-0 sec; a) thru d) can be accomplished by patching in the existing CMG.
Data Recording Set (DRS)	Monitor 1. PIBOL functions on existing spares; a) 1-11 - PIBOL Sequencer outputs b) 12 Auto - PIBOL Relay Contacts c) 13 Auto - PIBOL Relay Coils d) 14 Stage III Rate Gyro SMRD Go e) 15 Stage III Rate Gyro Heaters Go
Vehicle Checkout Set (VECOS)	Revise tape program, use 9 spare bits, revise two frames, add 50 new frames.
Interconnections	Add the following wires: a) Between DRS and Umbilical - approx 25 b) Between DRS and VECOS - approx 15 c) Between DRS and CMG - approx 7 d) Between CMG and DRS - approx 2

E. LOGISTICS CONSIDERATIONS

1. Maintainability of the PIBOL Design

Good maintainability practices were incorporated within the scope of this study effort.

The principles of MIL-M-26512B, Maintainability Requirements for Aerospace Systems and Equipment, Sec 3.1.1a, are: "Design to minimize the complexity of maintenance tasks by maximum use of simple design, which includes optimum interchangeability and use of standardized equipment or commercial item. These are complied with as closely as possible without degenerating good engineering practices as applied to this complex system.

The requirements of MIL-M-26512B, Sec 3.1.1b, "Design for rapid and positive recognition of equipment malfunction or marginal performance" are accomplished in the proposed VECOS program tape changes and additions.

The requirements of MIL-M-26512B, Sec 3.1.1e, "Design to require minimum numbers and types of tools and test equipment needed to perform maintenance," are incorporated by using the existing VECOS with modifications rather than specifying a new tool, especially for PIBOL checkout and maintenance.

The requirements as outlined in MIL-M-26512B, Sec 3.1.1i, "maximize the extent that performance can be verified," have been complied with. Checkout procedures have been outlined that require the addition of more frames to the VECOS tape to assure that the PIBOL system is in a ready condition before launch.

F. PROGRAM IMPLEMENTATION

1. Production Implementation Plan

This plan presents the manufacturing concept to assure timely incorporation of PIBOL into the Titan III follow-on production program. Production has been considered for six missiles, one for research and development and five for production.

In defining the scope of the plan, consideration was given to the circumstances that will prevail during the follow-on production program regarding requirements, capabilities of facilities, existing manufacturing potential, and basic materials availability.

a. Airborne Tooling Concept

Martin will design, fabricate, and maintain tools and related manufacturing equipment needed to manufacture the PIBOL components for the Titan III follow-on SSLV boosters. The following is new tooling required for components and assemblies:

- 1) Adapter-Programmer - Modify three tools and rework four test process plans;
- 2) Sequencer - Build eight new module-level tools and one new subsystem-level tool and create nine test process plans;
- 3) Stage III Rate Gyro System - None;
- 4) Signal Selector Switch - None;
- 5) Lateral Acceleration Sensing System - Stage I, none;
- 6) Airborne Wiring Harness - Modify one adapter cable and four patchboards for the Digital Continuity Checker (DITMCO);
- 7) Instrumentation Truss Assembly - Detail template, master coordinator template, and locator fixture;
- 8) Guidance Truss Assembly - Master coordinator template, drill jig, mill fixture, and templates.

b. OGE Tooling Concept

Full use will be made of existing tooling required for building ground equipment. No new tooling requirements are foreseen at this time.

c. Fabrication

Detail and subassembly fabrication will be on a line-need basis. Manufacturing procedures, methods, and processes developed and proved on the R&D, Titan III follow-on production program, and previous contracts, will be used for the PIBOL program.

The fabrication effort on OGE anticipated at this time is confined to a new VECOS tape and additional procedures.

d. Significant Production Steps

Significant steps in the production of the PIBOL vehicle differing from those in the follow-on production program are illustrated in Fig. 33. Lead times for PIBOL-pertinent items are shown.

Major changes to the Stage I oxidizer tank will be the addition of brackets to the manhole cover (modification of existing equipment) for installation of the Stage I accelerometer package (additional procurement of existing hardware).

The major change to the two transtage trusses is the placement of bracketry on the trusses and the installation of additional equipment, as defined:

- 1) Adapter programmer - Modify existing equipment;
- 2) Sequencer - New equipment;
- 3) Guidance and instrumentation truss assemblies - Modify existing equipment;
- 4) Selector switch - Identical to existing equipment;
- 5) Additional plugs, wires, and assorted details - New procurement and fabrication items;
- 6) Stage III rate gyro system - Identical to existing equipment.

SSD-CR-64-32

Legend:

- 1. P/O Placed
- 2. Material Available
- 3. Det/Tool Complete
- 4. Subassembly
- 5. Assembly Complete
- 6. Test Complete
- 7. Job Order Issued
- 8. Manhole Cover Fabrication Complete
- 9. On-Dock, Denver
- 10. Major Weld Start
- 11. Major Weld Complete
- Final Assembly Start
- Final Assembly
- 12. F/A Complete, VTF Start
- 13. VTF Complete (Vehicle Accepted)

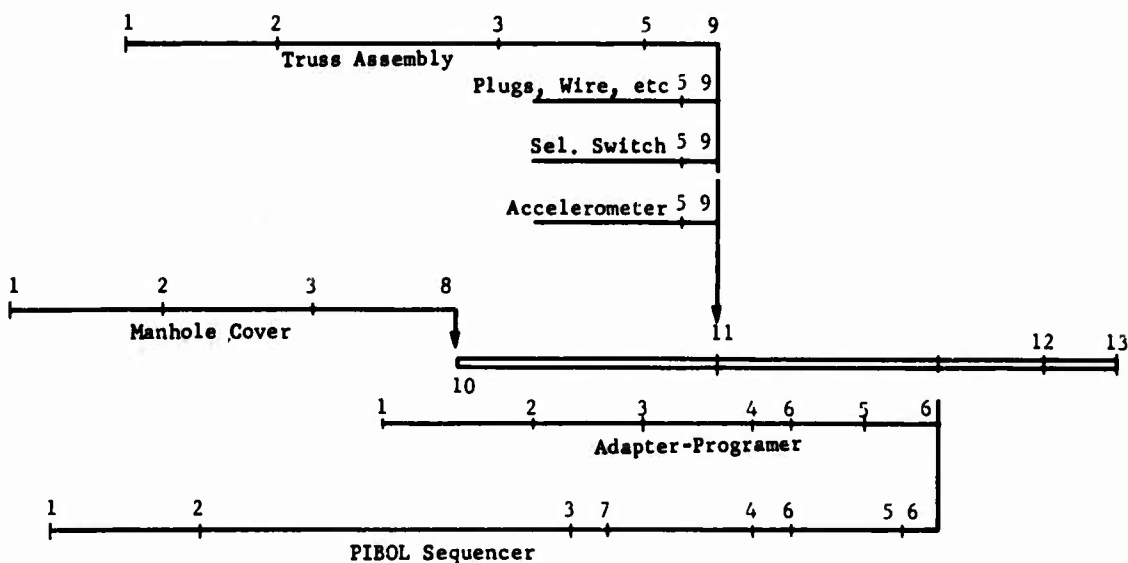

Note: Major schedule bar (10 thru 13) identical to standard Titan III build and is shown for reference only.

36 35 34 33 32 31 30 29 28 27 26 25 24 23 22 21 20 19 18 17 16 15 14 12 11 10 8 7 6 4 3 2 0
Span Time (week)

Fig. 33 PIBOL Production Steps

The production process consists generally of the same processes as those used on the follow-on production program. Martin will follow the same general plan for sub-contract effort as that established for the follow-on production program.

Product quality of manufactured items will be assured by sequential test of activities that range upward from a detail component level through total acceptance testing.

2. Program Implementation

Subsequent to the PIBOL feasibility study program, an implementation program will be initiated to provide selected 624A launch vehicles with PIBOL capability.

The PIBOL implementation program will be divided into two phases:

- 1) Phase I, Definition, consists of preparing specifications and plans to provide a sound technical basis and orderly transition to the acquisition phase;
- 2) Phase II, Acquisition, consists of design, development, and acquisition of hardware defined in Phase I to incorporate the PIBOL capability into the Basic 624A launch vehicle, and culminating in system flight test.

An evaluation of the differences between the proposed Basic PIBOL system and the Broader PIBOL concept revealed that the master schedules and master planning for either system will be identical. The reason is that, in development and availability of equipment, the sequencer (common to either the Basic or Broader system) is the controlling item. Therefore, this program plan summary and the attached schedule may be used for either approach.

A synopsis of the planning guidance and/or restrictions applying to the implementation program is given in the following planning ground rules and assumptions.

General - All implementation planning has been related to the X-20A configuration and characteristics and the PIBOL study ground rules. This planning will not necessarily be applicable to other payloads. 624A associate contractors whose equipment interfaces with PIBOL system components will be authorized to work in conjunction with the PIBOL integrating contractor. The PIBOL system will be incorporated into selected 624A vehicles on an in-line production basis. Booster selection will be established at the time of Phase II contract go-ahead. PIBOL unique specifications and procedures will be developed and controlled separately from the 624A specifications, but will incorporate 624A specifications by reference as much as possible. All planning and costs are based on the PIBOL program being concurrent with the 624A Phase III production and flight operations. The need for PIBOL-equipped boosters is assumed to be so slight that continuous production will not be necessary. Since 624A Phase III production incorporates the block plan concept, PIBOL vehicles will be exceptions to the 624A block plan. Any change to schedule or cost of the 624A Phase III program because of block plan modifications will be subject to negotiation.

Build and Acceptance - New tooling needed will be soft tooling only, and will be capable of fabricating the quantities as specified by the master schedules. Necessary changes to ground checkout equipment in the vertical test cells will be designed so the test cell can easily accept PIBOL testing interspersed with 624A vehicle testing. Sources of procured components in use for the 624A booster will be acceptable for PIBOL, and new sources will not be required.

Testing - Component and subsystem development testing and/or evaluation testing will be under the cognizance of engineering. Prototype units are to be built and tested to provide design data and design confirmation.

Denver Captive Tests - Stand D-1 will be used for captive firing all PIBOL vehicles. Changes to test stand and operating equipment will be designed so the test stand can easily accept PIBOL testing interspersed with 624A vehicle testing. Stand use will be negotiated to be compatible with the 624A requirements.

Atlantic Missile Range - Flight test operations will be conducted from Stands P-40 and P-41.

Phase I

Using the results of the PIBOL feasibility study, a contract for Phase I will be negotiated and awarded so specifications and plans can be prepared in sufficient detail to allow contracting for the acquisition phase, Phase II.

During Phase I, engineering criteria will be established as the basis for specifications to be prepared. Specifications to be prepared will define PIBOL-unique equipment, and will interface between the PIBOL system and various 624A subsystems. During Phase I, the contractor will develop detail planning for Phase II.

Phase I will be concluded by approval of specifications and plans. A minimum time for negotiation of Phase II will be required after concurrence to the technical program and after Phase II preplanning has been completed.

Coordination and integration will occur during Phase I so specification changes affecting 624A associate contractor subsystems will be technically approved at the end of Phase I.

Phase II

Contract negotiations for Phase II will start at the conclusion of Phase I. The Phase II contract will incorporate the specifications and plans prepared and technically approved during Phase I. A nominal (and arbitrary) negotiation period of 10 weeks between the conclusion of Phase I and the go-ahead for Phase II has been assumed for planning purposes.

Within 2 weeks after go-ahead, long-lead procurement will be released, based on procurement specifications developed during Phase I. At the same time, design engineering will be initiated. Five months is planned for the engineering span time required to design new hardware, modify existing 624A hardware, and re-release added quantities of identical existing 624A components. Prototype build of PIBOL components will start part way through the design span time. Development testing of the prototype components will be done under the cognizance of engineering.

With the release of design engineering, the necessary requisition of material and parts for the production build of PIBOL components will be issued, and the material and parts will be staged. Long-lead procurement will have been released previously.

The production of the longest spanned component, the sequencer, is scheduled for 4½ months after parts and material staging. Within the 4½-month period, detail parts will be fabricated and assemblies built and tested.

All PIBOL components can be available to the 624A production line within 10½ months after Phase II go-ahead. Depending on contract go-ahead, a standard 624A booster can be fabricated as a PIBOL booster by including PIBOL components, if the last PIBOL components were available to the production line half way through the final assembly period, or 1½ months before the booster entered VTF. A PIBOL booster can be built and accepted 13 months after Phase II go-ahead.

As an example, if Phase I go-ahead is assumed to be 1 October 1964, and Phase II go-ahead is assumed to be 1 May 1965, 624A Booster No. 22 could be selected as the development or first PIBOL 624A booster. This is based on the proposed Titan III, Phase III production plan of 48 boosters being built at the rate of 2 boosters per month. The first booster is to be accepted in March 1966. Booster No. 22 will be accepted during May 1966.

The PIBOL implementation master schedule (Table 15) has a time bar established by number of months rather than a particular calendar scale. It can be used as a sliding scale, and the earliest PIBOL booster can be determined by superimposing the PIBOL scale for any go-ahead with the Titan III production master schedule. Table 14 is the 624A Phase III proposed acceptance schedule.

The planning conducted for the PIBOL implementation program does not appreciably increase the 624A booster assembly or test time. The added PIBOL components are scheduled to be built and staged to meet the booster on the production line. Although additional assembly and test work will be required, a schedule by weeks or months is too gross to depict any change in booster fabrication span time.

In addition to the development and design confirmation testing of prototype PIBOL component items, more extensive testing is planned:

- 1) Controls Mock-Up Unit (CMU) - The CMU will simulate and test the flight controls subsystem as a complete entity;

- 2) Vertical Test Cell - Four weeks is planned for the PIBOL-equipped booster in VTF, rather than the normal three weeks, to permit engineering tests of the PIBOL subsystem as an integral part of the total booster;
- 3) Systems Compatibility Firing (SCF) - Every PIBOL missile will be captive fired in Denver subsequent to acceptance and before shipment to AMR;
- 4) Design Assurance Testing (DAT) - Extensive qualification testing in simulated flight environments will be conducted to prove specification compliance, and DAT will be completed before the first flight.

Plans were developed on the basis of fabricating, testing, and flying a development PIBOL/624A booster, followed by construction of five additional boosters. All six vehicles could be built as one lot within a three-month period, assuming that the 624A Phase III program will be operating at the rate of two boosters per month. For planning purposes, however, acceptance of the five additional boosters will be delayed until the development article has been flown. Results will be incorporated in the hardware or procedures for the five subsequent boosters. A six-month span has been arbitrarily established between the fabrication of the development article and the first of the production quantity. A build rate of one per quarter has been scheduled for the production quantity. Captive firings and launches are planned at similar time intervals.

Table 14 Proposed 624A Phase III Booster Acceptance Schedule (Complete Out of VTF)

Booster No.	Acceptance Date	Booster No.	Acceptance Date
18	March 1966	42	March 1967
19	April 1966	43	April 1967
20	April 1966	44	April 1967
21	May 1966	45	May 1967
22	May 1966	46	May 1967
23	June 1966	47	June 1967
24	June 1966	48	June 1967
25	July 1966	49	July 1967
26	July 1966	50	July 1967
27	August 1966	51	August 1967
28	August 1966	52	August 1967
29	September 1966	53	September 1967
30	September 1966	54	September 1967
31	October 1966	55	October 1967
32	October 1966	56	October 1967
33	November 1966	57	November 1967
34	November 1966	58	November 1967
35	December 1966	59	December 1967
36	December 1966	60	December 1967
37	January 1967	61	January 1968
38	January 1967	62	January 1968
39	February 1967	63	February 1968
40	February 1967	64	February 1968
41	March 1967	65	March 1968

Table 15 PIMOL Implementation Master Schedule

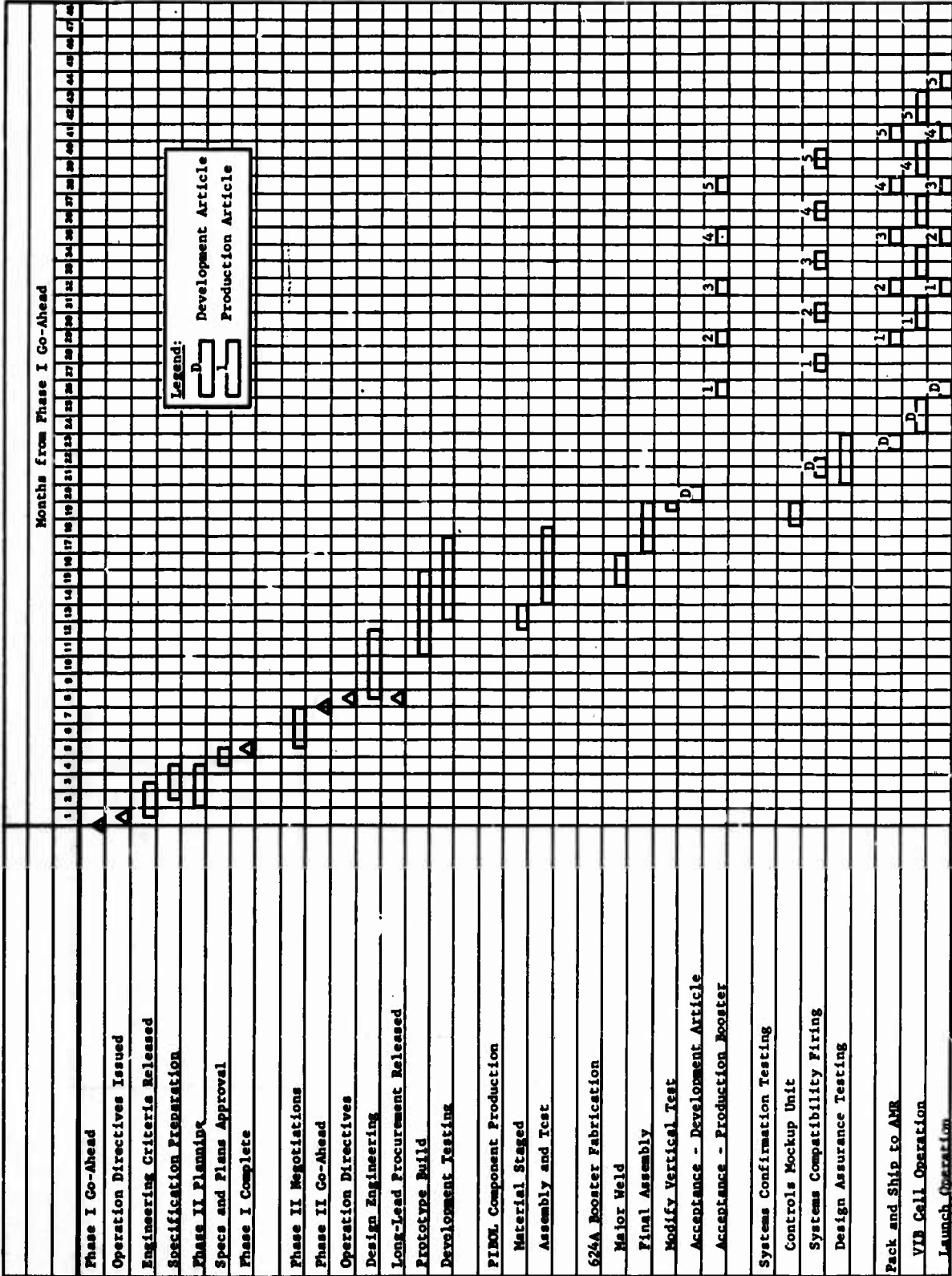

3. Program Cost

BASIS OF ESTIMATE

PIBOL IMPLEMENTATION PROGRAM PLAN

The purpose of this budgetary cost proposal is to reflect the costs that are associated with implementing the PIBOL System. The PIBOL System shall be incorporated into selected 624A Phase III Vehicles on an in-line basis for five (5) units, one (1) additional unit will be for development of the PIBOL System. Elements of cost will be broken down into three (3) phases:

1. Definition

Preparation of specifications, criteria, and plans

2. Development

Design and development of one (1) unit

3. Implementation

Implementation of the PIBOL System into five (5) units

Costs will be based on the PIBOL Program to be concurrent with the 624A Phase III Production Testing and Flight Operations Program. Any change to proposed schedule will require an analysis for cost impact.

BASIS OF ESTIMATEDEFINITION PHASE OF PROGRAM

Costs reflected in this portion of the Program are for Engineering and Contract Technical Requirements for preparation of specifications.

DIRECT CHARGES

Direct Charges are computed at 27% of the Engineering and CTR direct labor dollars.

$$\$29,149 \times 27\% =$$

\$7,870
TO ECA

ENGINEERING LABOR

Engineering will be required for control and coordination of the design criteria and specifications, establishment and control of systems interface and integrity of system.

Effort estimated at:

	2,211 Hrs
Support @ 38% =	840 Hrs
Supervision @ 17% =	<u>519 Hrs</u>
Total	3,570 Hrs

CONTRACT TECHNICAL REQUIREMENTS (CTR)

Contract Technical Requirements is responsible for the generation, negotiation, documentation, interpretation and monitoring for compliance with the technical requirements for the PIBOL Program.

Effort estimated at:

2,295 Hrs

Total effort required for the Definition Phase of the Program is:

5,865 Hrs
TO ECA

BASIS OF ESTIMATEDEVELOPMENT PHASE OF PROGRAM

Cost reflected in this portion of the Program are for Engineering, Tooling, Manufacturing, Testing, Quality Control, and Logistics for development of the first unit. The following outlines the effort required:

DIRECT CHARGES

Direct Charges are computed at 27% of the Engineering and Logistics direct labor dollars.

Engineering	\$256,319 X 27% =	\$69,206
Logistics	18,530 X 27% =	<u>5,003</u>

Total Direct Charges

\$74,209
TO ECA

ENGINEERING LABOR

Engineering effort required for the development of the PIBOL System consists of:

Section O451 (Guidance and Control)

Revise flight control system design and test criteria, provide contractual specification inputs for incorporation of PIBOL concept	1,020 Hrs
Provide system design for PIBOL sequencer	340 Hrs
Design PIBOL sequencer details	2,550 Hrs
Build prototype sequencers	1,360 Hrs
Perform development tests on sequencer	2,890 Hrs
Design assurance tests	2,040 Hrs
Coordination with other divisions	2,210 Hrs
Conduct control mockup system design confirmation tests for PIBOL	1,700 Hrs
Redesign flight control adapter programmer to adapt to PIBOL requirements (additional gain states)	3,230 Hrs
Build prototype flight control adapter, Perform development and design assurance tests	<u>5,950 Hrs</u>
Total Guidance and Control	23,290 Hrs

BASIS OF ESTIMATEENGINEERING LABOR (cont'd)Section 0455 (A/B Electrical)

Design installation wiring, diagrams and schematics and circuit analysis	1,190 Hrs
Modification of static inverter and signal transfer switch	2,380 Hrs
Prototype build of static inverter	2,550 Hrs
Design development tests	<u>1,275 Hrs</u>
Total Airborne Electrical	7,395 Hrs

Section 5146 (AGE Electronics)

Has analysis and modification to VECOS, CMG, DRS, and interconnections	<u>1,360 Hrs</u>
Total AGE Electronics	1,360 Hrs

Section 0432 (Airborne Structures)

Stage I oxidizer tank manhole cover modification Modification of Stage III trusses	<u>1,530 Hrs</u>
Total A/B Structures	1,530 Hrs

Section 5141 (Systems Engineering)

Systems Engineering will perform system integration of PIBOL concept	<u>3,060 Hrs</u>
Total System Engineering	<u>3,060 Hrs</u>
Total Basic Engineering Labor	36,635 Hrs
Support @ 38%	13,921 Hrs
Supervision @ 17%	<u>8,595 Hrs</u>
Total Engineering	<u>59,151 Hrs</u>

BASIS OF ESTIMATETOOLING LABOR

Tooling Labor will be required for preplanning, process planning, scheduling and build of tools for the PIBOL Program consisting of:

Sequencer Package (Test console rack)
 Relay Driver (Cabinet bench type)
 Diode Matrix (Cabinet bench type)
 16 CPS Oscillating and Binary (Test console)
 Binary Network (Cabinet bench type)
 Acceleration Switch (Cabinet bench type)
 Adapter Programmer (Cabinet bench type)
 Five (5) Filters
 Three (3) Switching Units
 Modification of Operational Test Tool Simulators
 (Ten (10) OTTS involved)
 Instrumentation Truss Assembly
 Guidance Truss Assembly
 PIBOL Sequencer
 Manhole Cover

Effort estimated at:

21,080 Hrs

Total Tooling Labor

21,080 Hrs
TO ECA

TOOLING MATERIAL

Tooling Material \$2.46/Hr X 21,080 Hrs =

\$51,857
TO ECA

MANUFACTURING LABOR

Effort will be expended by Manufacturing for build of one (1) unit (harness, switch, P/C board, gyro package, mounting details for trusses, manhole cover, and sequencer)

1,020 Hrs

Total Manufacturing Labor

1,020 Hrs
TO ECA

BASIS OF ESTIMATEMATERIAL

Design Development Units required:

Pibol Sequencer	4 Units	@ \$ 3,250	=	\$13,000
Adapter Programmer	2 Units	@ 10,000	=	20,000
Signal Selector Switch	4 Units	@ 5,200	=	20,800
Static Inverter	4 Units	@ 3,000	=	<u>12,000</u>
Total Design Development Units				\$65,800

Design Assurance Units:

Pibol Sequencer	4 Units	@ \$ 3,250	=	\$13,000
Adapter Programmer	4 Units	@ 10,000	=	40,000
Signal Selector Switch	4 Units	@ 5,200	=	20,800
Static Inverter	4 Units	@ 3,000	=	<u>12,000</u>
Total Design Assurance Units				85,800

One (1) Development Unit for 1st Article:

Pibol Sequencer	1 Unit	@ \$ 3,250	=	\$ 3,250
Adapter Programmer	1 Unit	@ -	=	-
Signal Selector Switch	1 Unit	@ 5,200	=	5,200
Static Inverter	1 Unit	@ -	=	-
L.A.S.S.	1 Unit	@ 8,594	=	8,594
Rate Gyro	1 Unit	@ 19,015	=	<u>19,015</u>
Total Development Unit				<u>36,059</u>

Total Material

\$187,659
TO ECAQUALITY CONTROL

Estimated by percentage of Manufacturing, Tooling, and Test labor.

Manufacturing	27% X 1,020 Hrs	=	275 Hrs
Tooling	16% X 21,080 Hrs	=	3,373 Hrs
Test	26% X 6,808 Hrs	=	<u>1,770 Hrs</u>

Total Quality Control

5,418 Hrs
TO ECA

BASIS OF ESTIMATETEST LABOR

Test labor will be required to support Design Assurance and Design Development Test.

2,020 Hrs

Booster Integrity Test

254 Hrs

VTF Cell P-4

1,887 Hrs

Modification Test

812 Hrs

D-1 Test Stand

1,835 Hrs

Total Test Labor

6,808 Hrs

TO ECA

TEST MATERIAL

Test Material is estimated at:

\$8,810

TO ECA

LOGISTICS

Logistics effort will be required to support the PIBOL Program to develop technical manuals, generating spare requirements, maintenance analysis and maintainability. Effort estimated at:

4,250 Hrs

Total Logistics Labor

4,250 Hrs

TO ECA

AMR - CANAVERALAMR LABOR

AMR labor will be expended for changes to procedures for VECOS, CST, countdown, instrumentation and master control.

255 Hrs

TO ECA

SUBCONTRACT LABOR

Subcontract labor to modify one (1) ITL Complex AGE equipment interconnections. Effort estimated at

1,835 Hrs X \$9.77/Hr =

\$17,928

SUBCONTRACT MATERIAL

Subcontract Material for lugs, wires, terminal boards is estimated at:

1,400

Total Subcontract

\$19,328

TO ECA

BASIS OF ESTIMATEIN-LINE PRODUCTION PHASE OF PROGRAMDIRECT CHARGES

Direct Charges are computed at 27% of the Engineering direct labor dollars.

$$\$13,311 \times 27\% =$$

\$3,594
TO ECA

ENGINEERING LABOR

Support VTF and SCF Testing and Maintenance.

2,550 Hrs

Total Engineering Labor

2,550 Hrs
TO ECA

MANUFACTURING LABOR

Labor required for build of five (5) units is estimated at 1,020 Hrs/unit/5 units =

5,100 Hrs

Total Manufacturing Labor

5,100 Hrs
TO ECA

QUALITY CONTROL

Estimated by percentage of Manufacturing and Test.

Test 26% X 7,205 Hrs =

1,873 Hrs

Manufacturing 27% X 5,100 Hrs =

1,377 Hrs

Total Quality Control

2,250 Hrs
TO ECA

BASIS OF ESTIMATETEST LABOR

Test Labor to perform PIBOL Unique Tests for five (5) units is estimated at 1,441 Hrs per unit =

7,205 Hrs

Total Test Labor

7,205 Hrs
TO ECA

MANUFACTURING MATERIAL

Sequencer	5 Units @ \$ 3,250 =	\$16,250
Adapter Programmer	5 Units @ -	-
Signal Selector Switch	5 Units @ 5,200	26,000
Static Inverter	5 Units @ -	-
L.A.S.S.	5 Units @ 8,594	42,970
Rate Gyro	5 Units @ 19,015	<u>95,075</u>

Total Manufacturing Material

\$180,295
TO ECA

PIBOL IMPLEMENTATION PROGRAM PLAN

BUDGETARY

ESTIMATED COST ANALYSIS

ESTIMATE Budgetary Estimate for PIBOL

ENCLOSURE (1) OF MARTIN LTR.

CONTRACT NO. AF 04(695)-435

NO. _____

SHEET NO. 1 OF 3

LINE NO.	COST ELEMENTS	COLUMN NO. 1 Summary of Column No. 2,3, and 4			COLUMN NO.		
		MAN-HOURS	RATE	DOLLARS	MAN-HOURS	RATE	DOLLARS
1	DIRECT CHARGES			97,439			
2							
3	ENGINEERING LABOR	67,566		342,356			
4	ENGINEERING OVERHEAD			325,238			
5							
6	TOOLING LABOR	21,080		79,682			
7	TOOLING OVERHEAD			137,053			
8	TOOLING MATERIAL			51,857			
9							
10	MANUFACTURING LABOR	6,120		19,380			
11	MANUFACTURING OVERHEAD			33,334			
12	MANUFACTURING MATERIAL			367,954			
13							
14	QUALITY CONTROL LABOR	8,668		33,047			
15	QUALITY CONTROL OVERHEAD			56,841			
16							
17	LOGISTICS LABOR (ONSITE)	4,250		18,530			
18	LOGISTICS OVERHEAD(ONSITE)			17,604			
19	LOGISTICS LABOR (OFF SITE)						
20	LOGISTICS OVERHEAD (OFFSITE)						
21							
22	TEST LABOR	14,013		58,409			
23	TEST OVERHEAD			100,464			
24	TEST MATERIAL			8,810			
25							
26	GENERAL AND ADMINISTRATIVE			209,759			
27							
28	DIRECT CHARGES AMR			107			
29	LABOR AMR	255		1,334			
30	OVERHEAD AMR			942			
31	MATERIAL						
32	SUBCONTRACT AMR			19,328			
33							
34	DIRECT CHARGES						
35	LABOR						
36	MATERIAL						
37	SUBCONTRACT						
38	OVERHEAD						
39							
40							
41	TOTAL ESTIMATED COST			1,979,468			
42	XXXXXXXXXXXXX TARGET FEE			228,863			
43	TOTAL SELLING PRICE OR						
44	TOTAL ESTIMATED COST + FEE			2,208,331			

F-30(11-62)

NOTES:

APPROVED

DATE

MARTIN-MARIETTA CORPORATION
DENVER DIVISION

John J. ...
25 March 1964

PIBOL IMPLEMENTATION PROGRAM PLAN

BUDGETARY

ESTIMATED COST ANALYSIS

ESTIMATE Budgetary Estimate for PIBOL
 CONTRACT NO. AF 04(695)-435

ENCLOSURE (1) OF MARTIN LTR.
 NO. _____
 SHEET NO. 2 OF 3

LINE NO.	COST ELEMENTS	COLUMN NO. 2 Definition			COLUMN NO. 3 Development D.D. and D.A.T. Plus 1st Unit		
		MAN-HOURS	RATE	DOLLARS	MAN-HOURS	RATE	DOLLARS
1	DIRECT CHARGES			7,870			85,975
2							
3	ENGINEERING LABOR	5,865	4.97	29,149	59,151	5.07	299,896
4	ENGINEERING OVERHEAD		95%	27,692		95%	284,901
5							
6	TOOLING LABOR				21,080	3.78	79,682
7	TOOLING OVERHEAD						137,053
8	TOOLING MATERIAL						51,857
9							
10	MANUFACTURING LABOR				1,020	3.05	3,111
11	MANUFACTURING OVERHEAD						5,351
12	MANUFACTURING MATERIAL						187,659
13							
14	QUALITY CONTROL LABOR				5,418	3.76	20,372
15	QUALITY CONTROL OVERHEAD						35,040
16							
17	LOGISTICS LABOR (ONSITE)				4,250	4.36	18,530
18	LOGISTICS OVERHEAD(ONSITE)						17,604
19	LOGISTICS LABOR (OFF SITE)						
20	LOGISTICS OVERHEAD (OFFSITE)						
21							
22	TEST LABOR				6,808	4.05	27,572
23	TEST OVERHEAD						47,424
24	TEST MATERIAL						8,810
25							
26	GENERAL AND ADMINISTRATIVE		12%	7,765		12%	157,300
27							
28	DIRECT CHARGES						
29	LABOR						
30	OVERHEAD						
31	MATERIAL						
32	SUBCONTRACT						
33							
34	DIRECT CHARGES						
35	LABOR						
36	MATERIAL						
37	SUBCONTRACT						
38	OVERHEAD						
39							
40							
41	TOTAL ESTIMATED COST			72,476			1,468,137
42	PROFIT OR FIXED FEE						
43	TOTAL SELLING PRICE OR						
44	TOTAL ESTIMATED CPFF						

NOTES:

APPROVED *John A. Ahern*
 DATE 25 March 1964
 MARTIN-MARIETTA CORPORATION
 DENVER DIVISION

F-49(11-62)

PIBOL IMPLEMENTATION PROGRAM PLAN

BUDGETARY

ESTIMATED COST ANALYSIS

ESTIMATE Budgetary Estimate for PIBOL

ENCLOSURE (1) OF MARTIN LTR.

CONTRACT NO. AF 04(695)-435

NO. _____

SHEET NO. 3 OF 3

LINE NO.	COST ELEMENTS	COLUMN NO. 4 In-Line Production for Five (5) Units			COLUMN NO.		
		MAN-HOURS	RATE	DOLLARS	MAN-HOURS	RATE	DOLLARS
1	DIRECT CHARGES			3,594			
2							
3	ENGINEERING LABOR	2,550	5.22	13,311			
4	ENGINEERING OVERHEAD			12,645			
5							
6	TOOLING LABOR						
7	TOOLING OVERHEAD						
8	TOOLING MATERIAL						
9							
10	MANUFACTURING LABOR	5,100	3.19	16,269			
11	MANUFACTURING OVERHEAD			27,983			
12	MANUFACTURING MATERIAL			180,295			
13							
14	QUALITY CONTROL LABOR	3,250	3.90	12,675			
15	QUALITY CONTROL OVERHEAD			21,801			
16							
17	LOGISTICS LABOR (ONSITE)						
18	LOGISTIC , OVERHEAD(ONSITE)						
19	LOGISTICS LABOR (OFF SITE)						
20	LOGISTICS OVERHEAD (OFFSITE)						
21							
22	TEST LABOR	7,205	4.28	30,837			
23	TEST OVERHEAD			53,040			
24	TEST MATERIAL						
25							
26	GENERAL AND ADMINISTRATIVE			44,694			
27							
28	DIRECT CHARGES AMR		8%	107			
29	LABOR AMR	255	5.23	1,334			
30	OVERHEAD AMR		70.6	942			
31	MATERIAL						
32	SUBCONTRACT AMR			19,328			
33							
34	DIRECT CHARGES						
35	LABOR						
36	MATERIAL						
37	SUBCONTRACT						
38	OVERHEAD						
39							
40							
41	TOTAL ESTIMATED COST			438,855			
42	PROFIT OR FIXED FEE						
43	TOTAL SELLING PRICE OR						
44	TOTAL ESTIMATED CPFF						

FORM (11-C)

NOTES:

APPROVED *[Signature]*
 DATE 25 March 1964
 MARTIN-MARIETTA CORPORATION
 DENVER DIVISION

G. SPECIFICATION IMPACT

Implementation of the PIBOL program will affect four general areas of contractual specifications: the vehicle specification, OGE specifications, interface specifications, and the data requirements specifications.

A summary of the detail specifications affected and the changes required is as follows:

<u>Titan III Specification</u>	<u>Change Required</u>
SSS-TIII-010 SLV <u>Standard Space Launch Vehicle</u>	Modify flight control system description, Modify Section 4, Test Requirements, Revise acceptance orders for PIBOL-selected vehicles;
SSS-TIII-010 OGE/01FLOO <u>Control Monitor Group (CMG)</u>	Section 3 (Requirements) Revise to add new requirements for PIBOL timer and Stage III rate gyro operations;
SSS-TIII-010 OGE/01FB00 <u>Vehicle Checkout Set (VECOS)</u>	Section 3 (Requirements) Revise to include checkout and monitor of PIBOL, SMRD, and gyro operations;
SSS-TIII-00R ICS/AMR <u>Installation and Checkout, AMR</u>	Revise checkout requirement (GSTP) for VECOS to include PIBOL requirements, Revise checkout requirement (GSTP) for CMG to include PIBOL requirements, Revise checkout requirement (GSTP) for DRS to include PIBOL requirements, Revise ICS/AMR checkout requirements to include PIBOL-generated changes to cable routing and chassis interfaces,

Generate a new combined systems test procedure (GSTP) to include all above changes,

Revise ISTP procedures for flight control system to include check-out for PIBOL manual controls and indications,

Revise combined systems ISTP to include checkout of launch equipment (airborne and ground) operations in both automatic and PIBOL modes;

IFS-TIII-11001
Interface, IGS/SSLS Electrical

Revise requirements for normally closed relays on all ACSP discrete and steering signal outputs;

IFS-TIII-20002
Interface, SSLV/Spacecraft Electrical

Revise to include SSLS capability to accept pilot transfer command signals and pilot command signals for pitch, yaw, and roll; revise to include pitch and yaw acceleration signals from Stage I to pilot readout;

IFS-TIII-20003
Interface, SSLV/Spacecraft, Performance

Revise to include pilot capability of switching booster inertial guidance system out of the vehicle guidance and control loop and exercising of the vehicle;

IFS-TIII-20005
Interface, SSLS/Spacecraft Compatibility Test Specification

Revise to include test requirements to verify signal interfaces as established by -20002;

SSS-TIII-010 DRD
Data Requirements Document

Revisions to include line items and supporting descriptions of PIBOL-required submittable data, such as:

- 1) Specification tree,
- 2) Hardware specification,
- 3) Test reports.

IV. CONCLUSIONS AND RECOMMENDATIONS

A. CONCLUSIONS

The standard Titan III/X-20A Stage 0 pitch and yaw flight control system can be adapted to the Basic PIBOL requirements of this study by either of two methods:

- 1) The use of a displacement gyro system in Stage III (to replace attitude error signals from the booster inertial guidance system);
- 2) The use of a signal simulating the displacement gyro signal, i.e., integrating a rate gyro signal.

The second of these methods is preferred for Titan III, because of the deletion of the requirement for the added gyro, which simplifies the hardware added for PIBOL.

The Broader PIBOL concept is not compatible with the Stage 0 pitch and yaw Titan III/X-20A configuration. Although the desired handling characteristics can be attained by using rate channel gains 40 to 50% higher than is normal (without PIBOL), these high rate gains prohibit acquiring acceptable structural bending stability margins.

PIBOL handling requirements for Stages I, II, and III can be attained in a variety of configurations, most notably, with only rate feedback in the flight control system.

The most significant item in the PIBOL hardware mechanization is the PIBOL sequencer, which provides the in-flight sequencing signals required by the vehicle. This item is the only all-new component required for the PIBOL concept, and, thus, becomes the pacing item in the PIBOL development program.

The PIBOL roll axis requirements can be met for all stages with changes to the standard Titan III/X-20A flight control system required only during Stage 0 operation and Stage III operation. In the case of Stage 0, increased rate channel gains are required throughout that phase of flight. For Stage III, a roll rate gyro must be added to Stage III (none is available in the standard Titan III vehicle).

Either the Basic or Broader PIBOL mechanization is adequate in eliminating inertial guidance system steering command failures with the result that Titan III components other than IGS remain the limiting factors affecting probability of mission success.

The number of additional missions completed with PIBOL backup is a function of Stage III coast and powered flight time; increasing with missions of longer duration. The maximum attainable improvement for a mission approaching the maximum Titan III capability (i.e., 6 hr coast, 500 sec Stage III burn time) is 17.6 vehicles/1000 with a perfect PIBOL system. The mechanization schemes presented in this document provide a mission improvement of 17.4 vehicles/1000.

A mathematical model based entirely on hardware considerations to the exclusion of pilot performance factors does not present a complete picture of reliability potential in a PIBOL-equipped Titan III. The pilot may offset the mission reliability attainable with PIBOL to the extent that lesser probability of mission success is achieved with PIBOL than without.

Mission success probability is more sensitive to the term P SWITCH (switch reliability) than P PIBOL (PIBOL hardware reliability) in the mathematical model. Consequently, redundant contact sets in the mode transfer switch and redundant wiring between the switch and autopilot are recommended to minimize the probability of an abort during flight in the automatic mode.

The significant conclusions of this study are not affected by the particular payload (X-20A) configuration considered. Of significance is the fact that the PIBOL requirements, to which this study was conducted, can be attained with relatively simple mechanization concepts that are compatible with the existing Titan III hardware, and to a great extent, used existing Titan III hardware.

Refinements that have occurred in the analytical model of the flight control system during the period of this study (which were not factored into this study because of the contract ground rules) have little effect on the results of this study. These refinements, such as the use of distributed airload considerations and changes in sensor characteristics, will change the control system characteristics slightly, but the changes are designed to obtain the same general system response characteristics as those used in this study.

B. RECOMMENDATIONS

Before inclusion of PIBOL in any flight vehicle, a simulator program is required to verify that the results of this study, and the results of the study that defined the handling characteristic requirements, are jointly acceptable. An extensive simulation program, which could include the pilot training phase, is believed to be necessary before a final decision on PIBOL configuration is made. This simulation program should include the effects of coupling between the pitch, yaw, and roll axes.

The ground rules of this study required that the standard Titan III (without PIBOL) flight control system configuration not be changed to accept PIBOL. If the standard flight control system and the PIBOL flight control system are designed concurrently, it is believed that the two phases could be jointly optimized, resulting in a better overall system.

This study did not include any considerations for Stage III coast operation mechanization. Further studies to define coast mechanization concepts are necessary to complete the PIBOL concept.

Consideration of the PIBOL system during staging transients was omitted from this study because of the contract ground rules. Control during the Stage 0/Stage I staging sequence could prove to be a significant problem for the pilot, because of the large forces resulting from unsymmetrical thrust decay, and should be included in future studies.

Further evaluation of the Stage 0 roll handling characteristic requirements is recommended. A method of specifying requirements similar to that used in the pitch and yaw axis is advisable, because of the low torsional bending mode frequencies and resulting flight control system configurations present during Stage 0 operation, which result in effects occurring in the low frequency range, which are not accounted for in the present formulation of requirements.

Future PIBOL studies should include a detail failure analysis and evaluation of the pilot's capability to sense and overcome each of these failures. This phase of entering the PIBOL mode could provide a major task for the pilot.

Although the Titan III/X-20A PIBOL system requires only roll rate feedback during Stage III operation, other missions with more stringent Stage III handling requirements would require pitch and yaw rate feedback during Stage III flight. For this reason, a three-axis rate system (as proposed by this study) is recommended for future Titan III/PIBOL usage.

The aspect of pilot training was not considered in this study. It is submitted that the training phase will significantly affect the program schedules and costs, and should be included in future studies.

It is recommended that Titan III PIBOL studies for other payloads (i.e., MOL, etc) be initiated as early as possible so that the PIBOL concept can be fully integrated with the standard Titan III system.

REFERENCES

1. Pilot-in-the-Booster-Control Loop Study - Final Report (Vol I and II). D2-80762, December 1962, Seven Revisions Volume I, 12 February 1963.
2. Pilot-in-the-Booster Loop (PIBOL). Contract AF04(695)-435.

SSD-CR-64-32

A-1

APPENDIX A

VEHICLE AND MISSION DATA

Table A-1 Trajectory Parameters (Ref Traj 91363)

Parameter	Symbol	Units	Stage 0 Flight						Stage I				Stage II			Stage III	
			0 sec	30 sec	62 sec	80 sec	103.5 sec (Burnout)	117 sec (Start)	240 sec (Gain Change)	258 sec (Burnout)	Start (259.5)	360 sec	460 sec (Burnout)	472.5 (Start)	490.8 (Burnout)		
Mach No.	M	--	0	0.6014	1.682	2.608	4.039	4.461	14.216	16.34	16.29	--	27.3	27.09	27.06		
Thrust	T	lb	2.2×10^6	1.96×10^6	1.83×10^6	1.77×10^6	1.70×10^6	0.474×10^6	0.474×10^6	0.474×10^6	0.10006×10^6	40.10006×10^6	0.10006×10^6	16×10^3	16×10^3		
Dynamic Pressure	q	lb/in. ²	0	2.665	5.683	3.692	1.229	0.469	0.003	0.002	0.002	0.0003	0.004	--	--		
Mass	M	lb-sec ² /in.	3545	2844	2187	1841	1427	907.8	377.9	290.1	262.3	174.3	93.6	74.5	72.0		
Angle of Attack	α_0	deg	0	0.039	0.011	-0.019	-0.040	-0.027	8.39	8.96	9.096	--	0.756	1.6	1.49		
Velocity	V ₀	in./sec	0	7964	19559	29864	49274	57454	144412	169040	169197	231972	289272	290000	294000		
Rate of Change of Velocity	\dot{V}_0	in./sec ²	235	302	468	676	992	359.7	1202.1	1529	334.2	577.0	1165.8	123	127		
Inertial Attitude	θ_0	deg	90	74.9	51.5	40.2	29.3	24.5	7.8	7.4	7.4	3.6	-13.7	-13.8	-15.1		
Attitude Rate	$\dot{\theta}_0$	deg/sec	0	-0.708	-0.695	-0.559	-0.384	-0.339	-0.070	-0.024	-0.036	-0.036	0	-0.075	-0.075		

*Stage II roll thrust = 965 lb.

Table A-3 Weight Dependent Parameters

Parameter	Units	Stage 0 Flight						Stage I				Stage II				Stage III	
		0 sec	30 sec	62 sec	80 sec	103.5 sec (Burnout)	117 sec (Start)	240 sec (Gain Change)	258 sec (Burnout)	259.5 sec (Start)	364 sec (Midflight)	460 sec (Burnout)	472.5 sec (Start)	490.75 sec (Burnout)			
W	lbx10 ⁻⁶	1.3686	1.0981	0.84449	0.71087	0.55109	0.350	0.145	0.116	0.101	0.0673	0.0361	0.02875	0.0278			
Xcg	in.	828	818	801	788	762	705	460	347	240	186	44	-59	-60.75			
Xg	in.	1308	1308	1308	1308	1308	1274	1274	1274	500	500	500	205.8	205.8			
Lg	in.	480	490	507	520	546	569	814	927	260	314	456	264.8	266.5			
I _A yaw	lb-sec ² -in.	341E6	294E6	248E6	225E6	193.6E6	114.6E6	62.4E6	38.4E6	12.2E6	10.44E6	5.4E6	2.2E6	2.04E6			
I _A pitch	lb-sec ² -in.	303.4E6	270E6	231E6	212E6	186E6	114.6E6	62.4E6	38.4E6	12.2E6	10.44E6	5.4E6	2.18E6	2.01E6			
I _R	lb-sec ² -in.	47.1E6	34.9E6	22.6E6	16.1E6	9.3E6	0.276E6	0.276E6	0.276E6	0.192E6	0.192E6	0.192E6	0.148E6	0.145E6			
I _{YZ}	lb-sec ² -in.	--	--	--	--	--	--	--	--	--	--	--	--	--			

Note: E6 = x10⁶

Symbol Definition for Table A-3 thru A-9

ω	Modal frequency	W	Vehicle weight
Meq	Equivalent modal mass	Xcg	Vehicle center of gravity (Sta No.)
$\phi(x), \phi_{xy}(x)$	Mode slope at Sta X (rad./in.)	Xg	Gimbal Sta No.
$h(x), h_g(x)$	Mode deflection at Sta X (in./in.)	I _A	Vehicle moment of inertia (pitch and yaw)
ζ	Modal damping ratio	I _R	Vehicle moment of inertia (roll)
I _{eq}	Equivalent torsional inertia	I _{YZ}	Moment of inertia cross product (not used in analysis)

Table A-4 Lateral Bending Parameters, Stage 0 Pitch Axis

Mode	ω (cps)	Meg lb-sec ² /in.	$\phi(1315)$ $\times 10^5$	$h(1315)$ $\times 10^3$	$\phi(112)$ $\times 10^5$	$\phi(867)$ $\times 10^5$	$\phi(320)$ $\times 10^5$	$h(378)$ $\times 10^3$	$\phi(378)$ $\times 10^5$	$h(650)$ $\times 10^3$	$\phi(650)$ $\times 10^5$	ξ	Time (sec)
1	1.4165	0.002588	-0.222	0.934	0.999	-0.270	0.702	-0.835	0.503	-1.41	-0.064	0.008	0
2	2.6445		-0.064	-0.15	0.270	0.0082	-0.107	-1.44	-0.579	0.978	-0.732	0.01	0
3	3.7408		0.156	-0.394	-0.115	0.230	-0.812	0.0485	-0.818	0.393	0.529	0.015	0
1	1.465		-0.263	1.12	1.00	-0.316	0.689	-0.298	0.574	-1.14	0.023		30
2	2.756		-0.061	-0.286	0.298	0.023	-0.159	-0.708	-0.329	1.16	-0.718		30
3	3.875		0.200	-0.439	-0.243	0.261	-0.885	-1.28	-0.832	0.185	0.053		30
1	1.523		-0.308	1.335	1.00	-0.367	0.673	-0.484	0.556	-1.22	0.0013		60
2	2.886		-0.036	-0.481	0.318	0.047	-0.208	-0.973	-0.398	1.10	-0.738		60
3	4.042		0.245	-0.439	-0.398	0.305	-0.951	-0.988	-0.846	0.204	0.163		60
1	1.576		-0.347	1.522	0.997	-0.410	0.655	-0.641	0.535	-1.31	-0.027		80
2	3.004		-0.004	-0.716	0.317	0.083	-0.279	-1.20	-0.470	1.04	-0.749		80
3	4.234		0.273	-0.337	-0.567	0.351	-0.999	-0.617	-0.842	0.264	0.309		80
1	1.647		-0.395	1.758	0.982	-0.463	0.624	-0.130	0.590	-0.995	0.059		105
2	3.162		0.061	-1.09	0.283	0.154	-0.395	-0.476	-0.277	1.22	-0.664		105
3	4.601		0.279	0.019	-0.867	0.402	-1.06	-1.47	-0.808	0.250	-0.142		105

Table A-5 Lateral Bending Parameters, Stage 0, Yaw Axis

Mode	ω (cps)	Meq lb-sec ² /in.	$\phi(1315)$	h(1315)	$\phi(112)$	$\phi(887)$	$\phi(378)$	h(378)	$\phi(378)$	h(650)	$\phi(650)$	ξ	Time (sec)
1	1.272	0.002588	-0.154E-5	0.628E-3	0.897E-5	-0.188E-5	0.626E-5	0.535E-5	0.538E-5	-0.82E-3	0.107E-5	0.008	0
2	2.506		-0.626E-6	0.112E-3	0.409E-5	-0.746E-6	-0.305E-5	-0.121E-2	-0.451E-5	0.747E-3	-0.675E-5	0.01	0
3	3.526		-0.381E-5	-0.534E-3	-0.126E-5	-0.405E-5	-0.204E-5	0.201E-3	-0.278E-5	0.134E-2	-0.345E-5	0.015	0
1	1.314		-0.263E-5	0.112E-4	0.908E-5	-0.233E-5	0.616E-5	-0.116E-3	0.524E-5	-0.97E-3	0.657E-6	0.008	30
2	2.596		-0.061E-5	-0.286E-3	0.174E-5	-0.221E-6	-0.385E-5	-0.129E-2	-0.529E-5	0.866E-3	-0.701E-6	0.01	30
3	3.874		0.2E-5	-0.439E-3	-0.651E-5	0.188E-5	-0.845E-5	-0.406E-3	-0.631E-5	-0.431E-3	0.577E-5	0.015	30
1	1.373		-0.242E-5	0.103E-2	0.899E-5	-0.287E-5	0.594E-5	-0.325E-3	0.499E-5			0.008	60
2	2.687		-0.125E-6	-0.326E-3	0.106E-5	0.36E-5	-0.463E-5	-0.137E-2	-0.601E-5			0.01	60
3	4.115		0.253E-5	-0.246E-3	-0.955E-5	0.217E-5	-0.107E-4	-0.134E-3	-0.779E-5			0.015	60
1	1.428		-0.281E-5	0.122E-2	0.883E-5	-0.330E-5	0.564E-5	-0.505E-5	0.467E-5	-0.114E-2	0.4144E-7	0.008	80
2	2.762		0.219E-6	-0.566E-3	0.573E-6	0.873E-6	-0.525E-5	-0.142E-2	-0.655E-5	-0.918E-3	0.686E-5	0.01	80
3	4.332		0.369E-5	-0.472E-3	-0.113E-4	0.292E-5	-0.113E-4	0.25E-3	-0.797E-5	0.832E-4	0.709E-5	0.015	80
1	1.518		0.11E-5	-0.505E-3	-0.368E-5	0.131E-5	-0.21E-5	0.198E-3	-0.17E-5	0.409E-3	0.561E-7	0.008	105
2	2.863		0.8E-6	-0.93E-3	-0.165E-6	0.165E-5	-0.609E-5	-0.145E-2	-0.774E-5	0.948E-3	-0.655E-5	0.01	105
3	4.699		0.259E-5	0.107E-3	-0.14E-4	0.354E-5	-0.118E-4	0.851E-3	-0.786E-5	0.338E-3	0.83E-5	0.015	105

Note: E-n = 10⁻ⁿ.

Table A-6 Torsional Bending Parameters, Stage 0 Roll Axis

Node	ω (cps)	I_{eq} lb-sec ² /in.	$\phi(1315)$ $\times 10^5$	$\phi(112)$ $\times 10^5$	$\phi(887)$ $\times 10^5$	$\phi(320)$ $\times 10^5$	ζ	Time (sec)
1	2.1	0.002588	0.89E-5	-0.148E-4	-0.033E-4	-0.148E-4	0.01	0
2	3.3		-1.14E-5	0.056E-4	-0.1E-4	0.061E-4	0.01	0
3	8.25		-0.26E-5	-0.85E-4	-0.04E-4	-0.049E-4	0.01	0
1	2.39		0.9E-5	-0.169E-4	-0.046E-4	-0.167E-4	0.01	30
2	3.78		-1.39E-5	0.078E-4	-0.11E-4	0.083E-4	0.01	30
3	8.27		-0.269E-5	-0.86E-4	-0.04E-4	-0.5E-4	0.01	30
1	2.72		0.91E-5	-0.203E-4	-0.06E-4	-0.2E-4	0.01	60
2	4.30		-1.68E-5	0.099E-4	-0.128E-4	0.092E-4	0.01	60
3	8.33		-0.314E-5	-0.087E-4	-0.04E-4	-0.51E-4	0.01	60
1	3.15		1.1E-5	-0.247E-4	-0.071E-4	-0.238E-4	0.01	80
2	4.90		-1.9E-5	0.115E-4	-0.15E-4	0.108E-5	0.01	80
3	8.41		-0.322E-5	-0.87E-4	-0.04E-4	-0.52E-4	0.01	80
1	4.20		1.5E-5	-0.37E-4	-0.348E-4	-0.092E-4	0.01	105
2	6.20		-2.21E-5	-0.119E-4	0.1E-4	-0.2E-4	0.01	105
3	8.58		0.531E-5	-0.87E-4	-0.53E-4	0.01E-4	0.01	105

Note: $E-n = 10^{-n}$.

Table A-7 Stage I Lateral Bending Parameters

Mode	ω (cps)	Meq (lb-sec ² /in.)	(Stage I Start)						hg(1274) (in./in.) (tip deflection)
			$\phi_{gy}(112)$ (rad/in.)	$\phi_{gy}(887)$ (rad/in.)	$\phi_{gy}(320)$ (rad/in.)	$\phi_{gy}(1274)$ (rad/in.)	$\phi_{gy}(1274)$ (rad/in.)		
1	1.951	0.002588	0.1653E-4	-0.7471E-5	0.5504E-5	-0.9517E-5	0.3109E-2		
2	3.659	0.002588	0.4278E-4	0.6701E-5	-0.7386E-5	0.1386E-4	-0.3246E-2		
3	6.216	0.002588	-0.2353E-4	-0.1293E-5	-0.9692E-5	-0.1486E-4	0.239E-2		
1	2.349	0.002588	0.1056E-4	-0.8643E-5	0.3347E-5	-0.1098E-4	0.4167E-2		
2	5.094	0.002588	-0.1617E-4	0.1063E-4	-0.1540E-4	0.2153E-4	-0.4337E-2		
3	7.677	0.002588	-0.1705E-4	-0.1146E-4	0.3250E-5	-0.4312E-4	0.6205E-2		
1	2.526	0.002588	0.9092E-5	-0.1114E-4	0.1342E-5	-0.1449E-4	0.665E-2		
2	5.357	0.002588	-0.1964E-4	0.1002E-4	-0.1573E-4	0.1894E-4	-0.0042		
3	9.846	0.002588	-0.6279E-5	-0.1155E-4	0.1959E-4	-0.3906E-4	0.00445		

Note: E-n = 10⁻ⁿ.

Table A-8 Stage II Lateral Bending Parameters

Mode	(Stage II Start)							hg(499) (in./in.) (tip deflection)
	ω (cps)	Meq (lb-sec ² /in.)	$\phi_{gy}(112)$ (rad/in.)	$\phi_{gy}(320)$ (rad/in.)	$\phi_{gy}(499)$ (rad/in.)			
1	4.316	0.002588	-0.1138E-4	-0.2048E-4	-0.1903E-4			0.3478E-2
2	9.510	0.002588	-0.1489E-4	0.3161E-4	0.2752E-4			-0.482E-2
3	13.24	0.002588	0.3206E-4	-0.2553E-4	-0.2489E-4			0.4425E-2
(Stage II Midflight)								
1	4.611	0.002588	-0.1686E-4	-0.2363E-4	-0.2348E-4			0.5389E-2
2	10.49	0.002588	-0.2338E-5	0.3041E-4	0.3171E-4			-0.5352E-2
3	15.43	0.002588	0.3403E-4	-0.4281E-4	-0.517E-4			0.7024E-2
(Stage II Burnout)								
1	4.804	0.002588	-0.2134E-4	-0.2803E-4	-0.2832E-4			0.7833E-2
2	10.67	0.002588	0.1625E-5	0.3198E-4	0.3428E-4			-0.0066
3	15.95	0.002588	0.3108E-4	-0.4152E-4	-0.4982E-4			0.0071

Note: E-n = 10⁻ⁿ.

Table A-9 Stage I and Stage II Torsional Bending Parameters

	Mode	ω (cps)	I_{eq} (lb-sec ² /in.)	$\phi(119)$	$\phi(320)$	$\phi(1274)$	$\phi(499)$
Stage I	1	10.976	0.002588	0.2E-4	-0.2E-4	-0.14E-3	--
	2	20.514	0.002588	-0.6E-4	-0.4E-4	+0.4E-4	--
Stage II	1	17.327	0.002588	-0.12E-3	-0.16E-3	--	-0.19E-3
	2	21.146	0.002588	0.3E-4	0.5E-4	--	0.6E-4

Note: E-n = 10⁻ⁿ.

SSD-CR-64-32

B-1

APPENDIX B

SECOND ORDER APPROXIMATION METHODS

A. TRANSIENT RESPONSE FIT METHOD

This method for determining a second order system that approximates the transient response characteristics of a higher order system was used for the Stage 0 pitch and yaw handling characteristic analysis.*

1. The Effective Level of the Response (R_o)

a. Oscillatory Response

R_o is determined by equating the subsidence of the first overshoot and first undershoot, shown in Fig. B-1 as points P_1 and P_2 , respectively. This gives an expression for R_o in terms of the value of the response at these points.

$$R_o = \frac{(R_1)^2}{(2R_1 - R_2)} \quad [1]$$

b. Well Damped and Non-Oscillatory Responses

The steady level will undoubtedly be clouded by the presence of low frequency dynamics in the closed loop transfer function, which causes the response either to rise or drop for an extended time after the initial transient. (These closed loop poles and zeros will most likely be associated with the normal force effects and with the integral of normal acceleration feedback dynamics.) If this is the case, the closed loop transfer function is to be modified by removal of these poles and zeros and the response of the resulting modified transfer function is to be considered to find ζ and ω_n .

The effective level of the response of the modified transfer function is found thru application of Eq [1] for both the oscillatory and non-oscillatory cases. When the overshoot reduces to zero, R_1 becomes equal to R_2 and the equation reduces to $R_o = R_1$.

*This method was provided as part of the PIBOL contract, and is repeated here for reference only.

2. Determination of the Overshoot Ratio

The overshoot ratio is defined as the difference between the first overshoot (R_1) and the effective level of the response (R_o) divided by the effective level of the response.

$$\text{Overshoot Ratio} = \frac{R_1 - R_o}{R_o} \quad [2]$$

3. Responses with Overshoot Ratios Greater than 0.05

a. Damping Ratio

The damping ratio ζ is uniquely defined by the overshoot ratio.

$$\text{Overshoot Ratio} = \exp \frac{-\zeta\pi}{\sqrt{1 - \zeta^2}} * \quad [3]$$

This expression can be solved to find the ζ associated with the given overshoot ratio or Fig. B-2 can be used to find ζ .

b. Natural Frequency ($-1 < \zeta < 0.3$)

The natural frequency (ω_n) for systems with $-1 < \zeta < 0.3$ is obtained by considering the time to the first overshoot (t_{P_1}) and time to the first undershoot (t_{P_2}). The average of the natural frequency defined by these two times is considered to be ω_n . This can be expressed as:

$$\omega_n = \frac{\pi}{\sqrt{1 - \zeta^2}} \left[\frac{1}{2t_{P_1}} + \frac{1}{t_{P_2}} \right] \quad [4]$$

The times t_{P_1} and t_{P_2} are in seconds to the first overshoot (P_1) and first undershoot (P_2) as shown in Fig. 1.

*exp [x] = e [x]

c. Natural Frequency ($0.3 < \zeta < 0.7$)

The natural frequency (ω_n) for systems with $0.3 < \zeta < 0.7$ is obtained by considering the rise time (t_R). Rise time is defined as the time in seconds for the response to go from 10 to 90% of its effective level (Fig. B-1). The relationship between rise time and natural frequency is defined by Fig. B-3.

4. Responses with Overshoot Ratios Less than 0.05

ζ and ω_n are found from Fig. B-4. The ratio of time (t_b) for the response to grow to 80.1% of the effective level over time (t_a) for the response to grow to 26.4% of the effective level gives the damping ratio ζ . This then gives a value for $\omega_n t_b$. Since t_b has been measured, ω_n can be calculated.

5. Time-to-Double Amplitude Criteria

If the response is oscillatory, construct envelope of response from 0 to 15 sec. Find centerline of envelope or take actual response curve for non-oscillating case. If centerline level at 15 sec does not have double the value it had at 10 sec then time-to-double amplitude is considered to be greater than 5 sec. (For Broader PIBOL system time-to-double amplitude > 5.0 sec.)

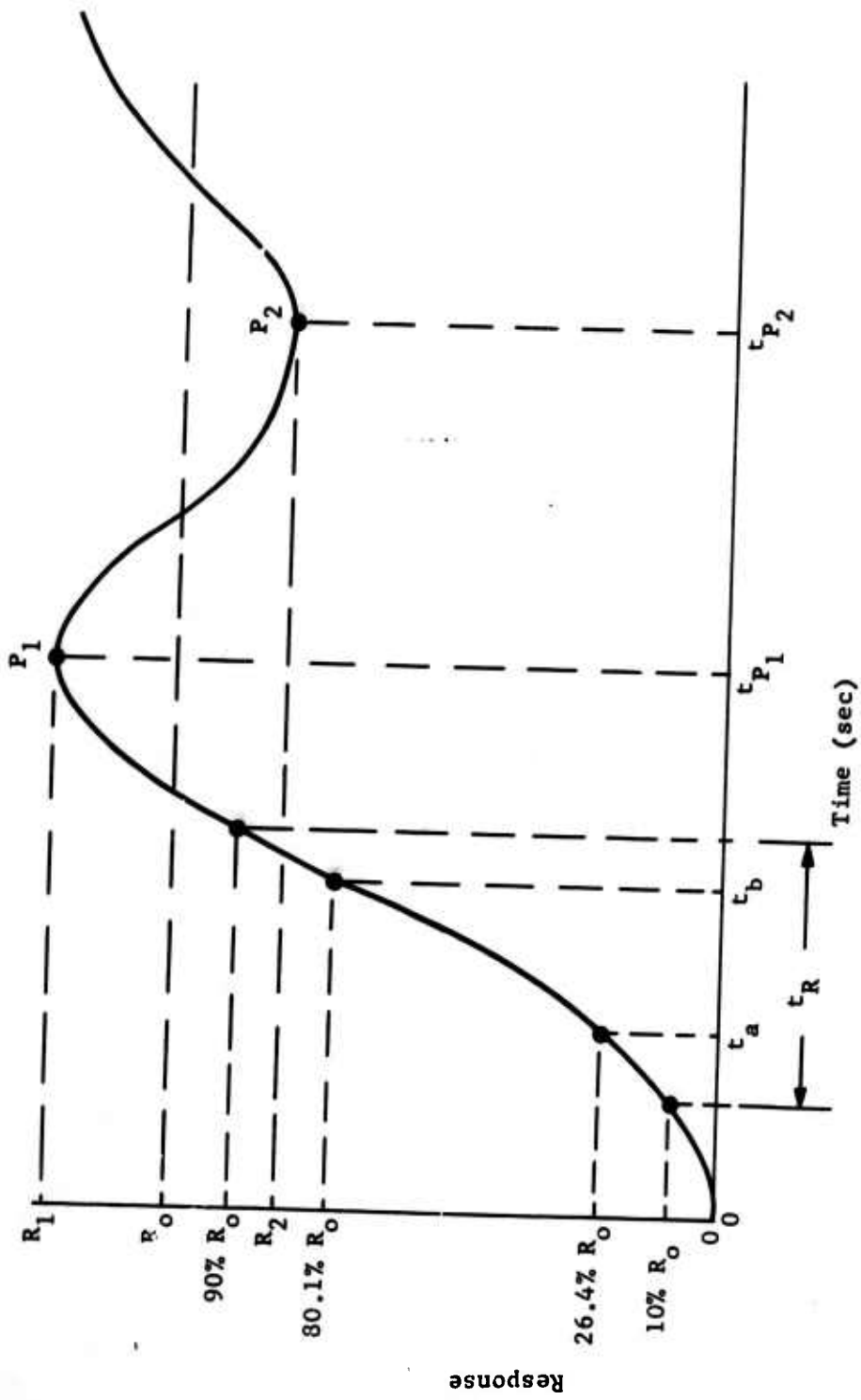

Fig. B-1 Oscillatory Response

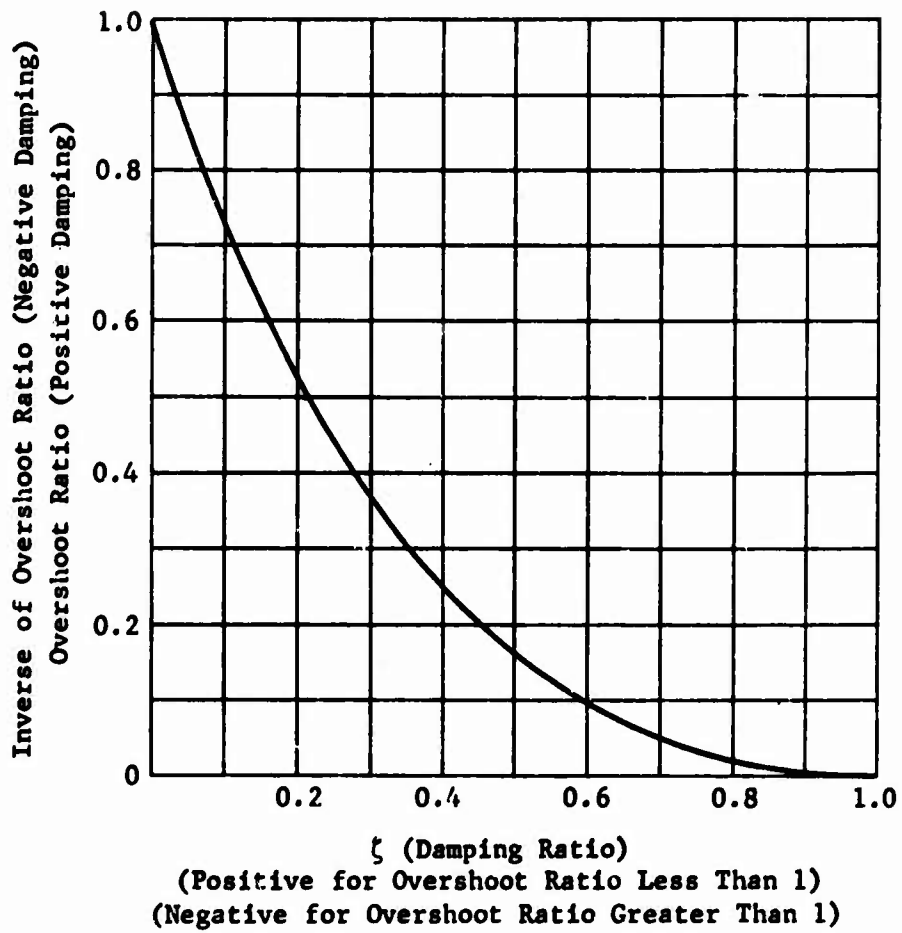

Fig. B-2 Responses with Overshoot Ratios Greater than 0.05

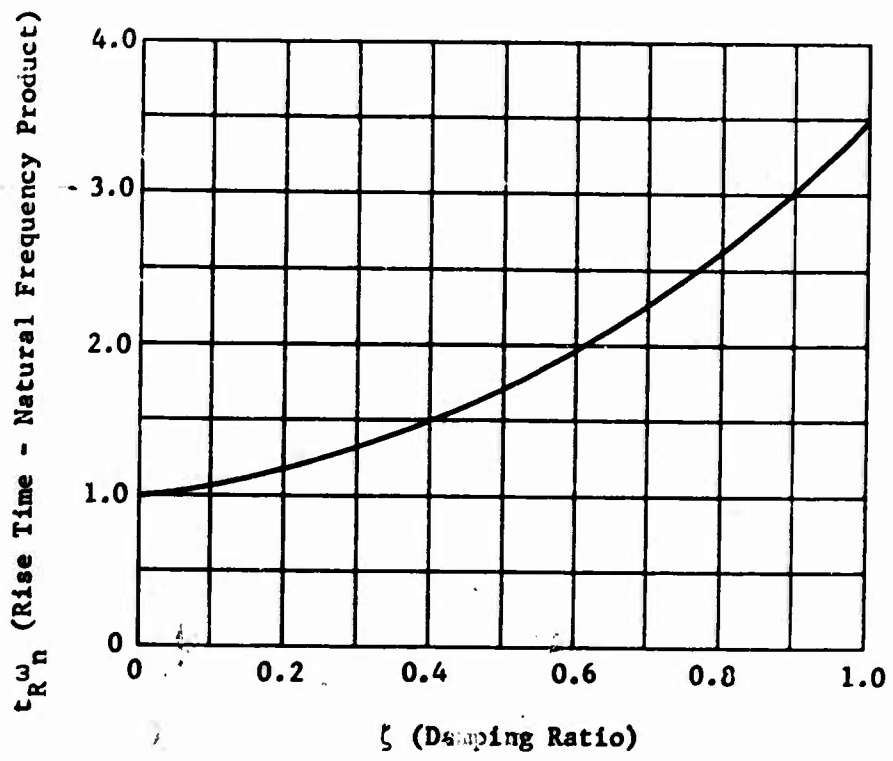

Fig. B-3 Relationship Between Rise Time and Natural Frequency

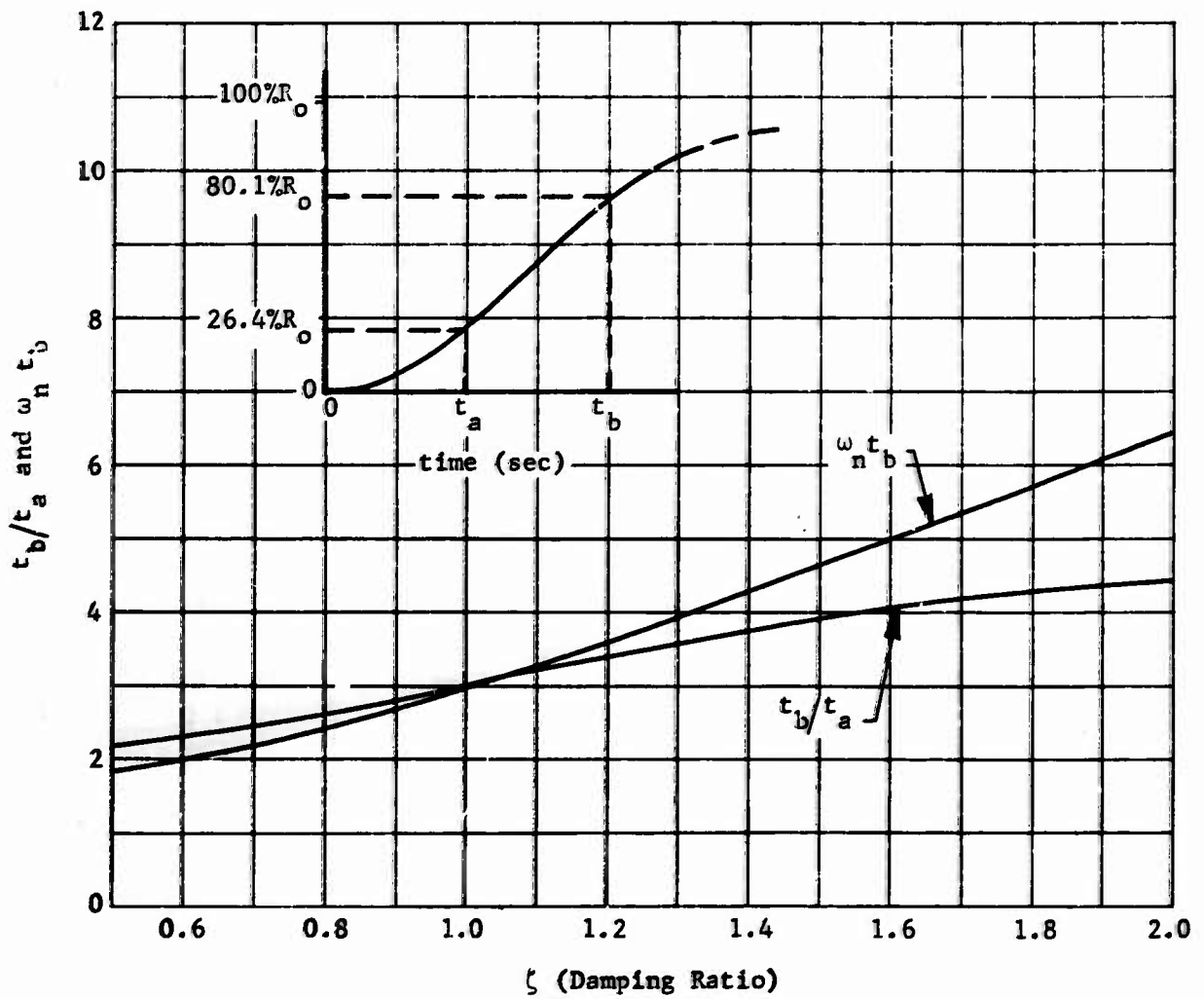

Fig. B-4 Responses with Overshoot Ratios Less than 0.05

B. EMPIRICAL METHOD

Equations for comparison of booster stability with handling characteristic requirements Stages I, II, and III, Pitch and Yaw are as follows:

Pitch Axis (Ref 1).

$$q = 0;$$

$$\omega_n^2 = A \frac{T(X_R - X_{CG})}{I_y}, 2\zeta\omega_n = B \frac{T(X_R - X_{CG})}{I_y}$$

$$q \gg 0;$$

$$\omega_n^2 = \frac{\frac{qSC_{Nz}}{I_y} (X_{acp} - X_{cg}) + A \frac{T(X_R - X_{CG})}{I_y} - C \left[\frac{TqSC_{Nz}}{MI_y} (X_{acp} - X_{cg}) \left(1 - \frac{(X_R - X_{CG})}{(X_{ac} - X_{CG})} \right) \right]}{1 - C \left[\frac{T}{I} + \frac{T}{I_y} (X_R - X_{CG})(X_{pa} - X_{cg}) \right]}$$

$$2\zeta\omega_n = \frac{\frac{qSC_{m\dot{\theta}}}{I_y} + \frac{T-D}{mV} + \frac{qSC_{Nz}}{mV} + B \frac{T(X_R - X_{CG})}{I_y}}{1 - C \left[\frac{T}{M} + \frac{T(X_R - X_{CG})}{I_y} (X_{pa} - X_{cg}) \right]}$$

Augmentation	A	B	C
Rate Only	0	$K_{\dot{\theta}}$	0
Rate + \int Rate	$Kf\dot{\theta}$	$K_{\dot{\theta}}$	0
Rate + Attitude	K_{θ}	$K_{\dot{\theta}}$	0
Rate + Attitude + Acceleration	K_{θ}	$K_{\dot{\theta}}$	K_{az}

where

X_{pa} = Body sta for pitch acceleration

\bar{c} = Mean aero chord

X_g = Body sta for engine gimbal

X_{acp} = Body sta for aero center in pitch

S = Wing area (aerodynamic reference area)

Since the accelerometer will not be used in Stage I, II, or III for $q \gg 0$;

$$\omega_n^2 = \frac{\frac{qSC}{I_y} N\alpha (X_{acp} - X_{cg}) + A \frac{T(X_g - X_{cg})}{I_y}}{1}$$

$$2\zeta\omega_n = \frac{\frac{qS\bar{c}}{I_y} m\dot{\theta} + \frac{T-D}{mV} + \frac{qSC}{mV} N\alpha + B \frac{T(X_g - X_{cg})}{I_y}}{1}$$

or translating to Martin Company terminology

for $q = 0$;

$$\omega_n^2 = \frac{K_{D,TL}}{I_{yy}}, 2\zeta\omega_n = \frac{K_{R,TL}}{I_{yy}}$$

for $q \gg 0$;

$$\omega_n^2 = \frac{qS_F L C N\alpha}{I_{yy}} + \frac{K_{D,TL}}{I_{yy}}$$

$$2\zeta\omega_n = \frac{qS_F dC_{mq}}{I_{yy}} + \frac{T-D}{mV} + \frac{qS_F C N\alpha}{mV} + \frac{K_{R,TL}}{I_{yy}}$$

APPENDIX C

BASIC PIBOL RESULTS

Recommended Stage 0 Pitch-Yaw System (Fig. C-1 thru C-28)

Stage 0 Pitch and Yaw with Displacement Gyros, Without Load Relief (Fig. C-29 thru C-35)

Stage 0 Pitch and Yaw with Displacement Gyros With Load Relief (Fig. C-36 thru C-39)

Stage I (Fig. C-40 thru C-44)

Stage II (Fig. C-45 thru C-48)

Stage 0 Roll (Fig. C-49 thru C-55)
Terminology

Flight Control System Configuration

Channel	Gain	Filter Configuration
Displacement	$K_{RD} = 1.72$	$\frac{K_{RD} 7.5}{(1 + 7.55)(1 + s/10)}$
Stage I Rate	$K_{R1} = 0.46$	$\frac{1}{(1 + s/40)^2}$
Stage II Rate	$K_{R2} = 0.17$	$\frac{1}{(1 + s/30)^2}$
Acceleration	$K_A = 0$	
Velocity	$K_V = 0$	

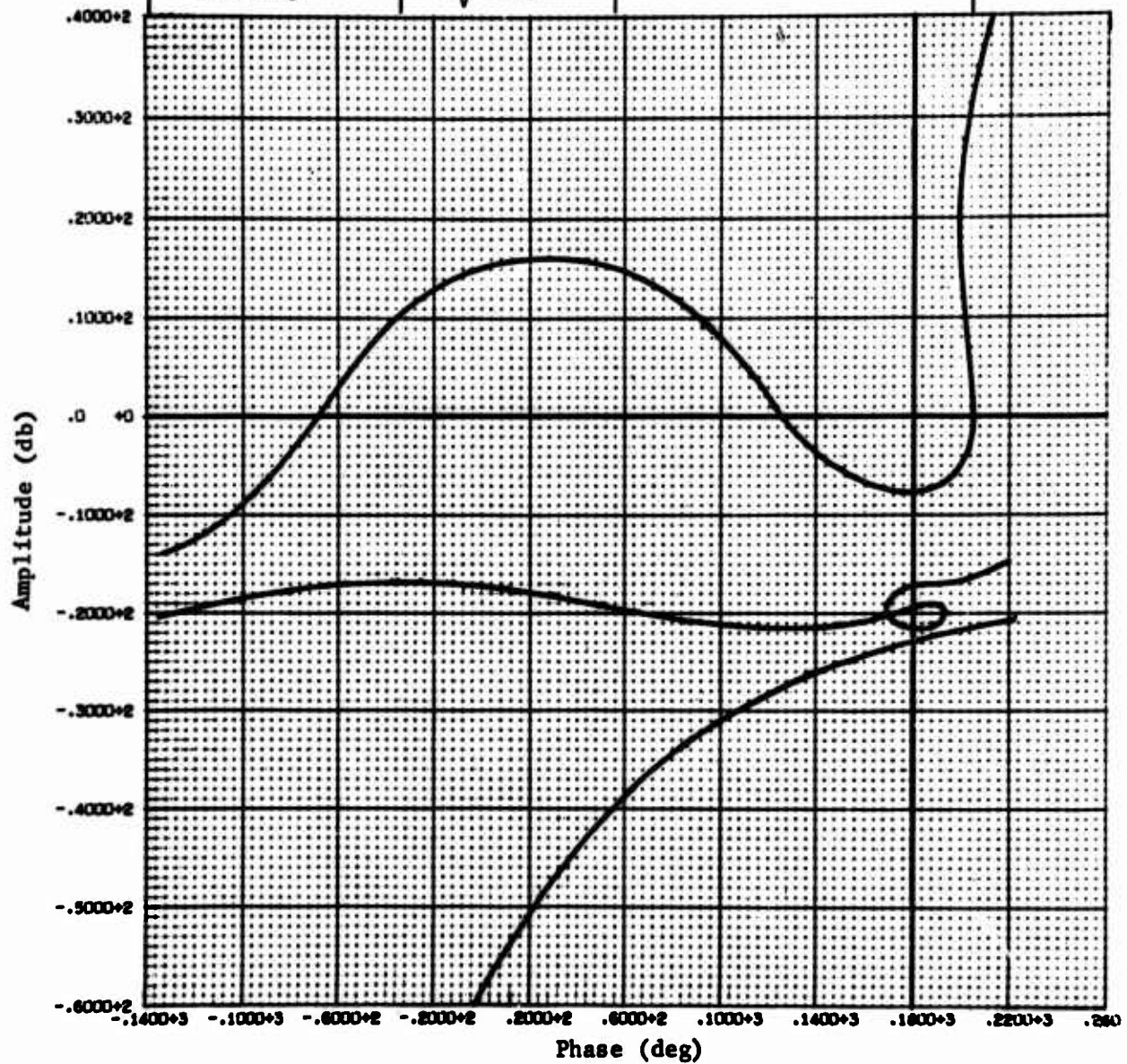

Fig. C-1 Open Loop Frequency Response, Pitch Axis (0 sec)

Flight Control System Configuration

Channel	Gain	Filter Configuration
Displacement	$K_{RD} = 1.72$	$\frac{K_{RD} 7.5}{(1 + 7.55)(1 + S/10)}$
Stage I Rate	$K_{R1} = 0.46$	$\frac{1}{(1 + S/40)^2}$
Stage II Rate	$K_{R2} = 0.17$	$\frac{1}{(1 + S/30)^2}$
Acceleration	$K_A = 0$	
Velocity	$K_V = 0$	

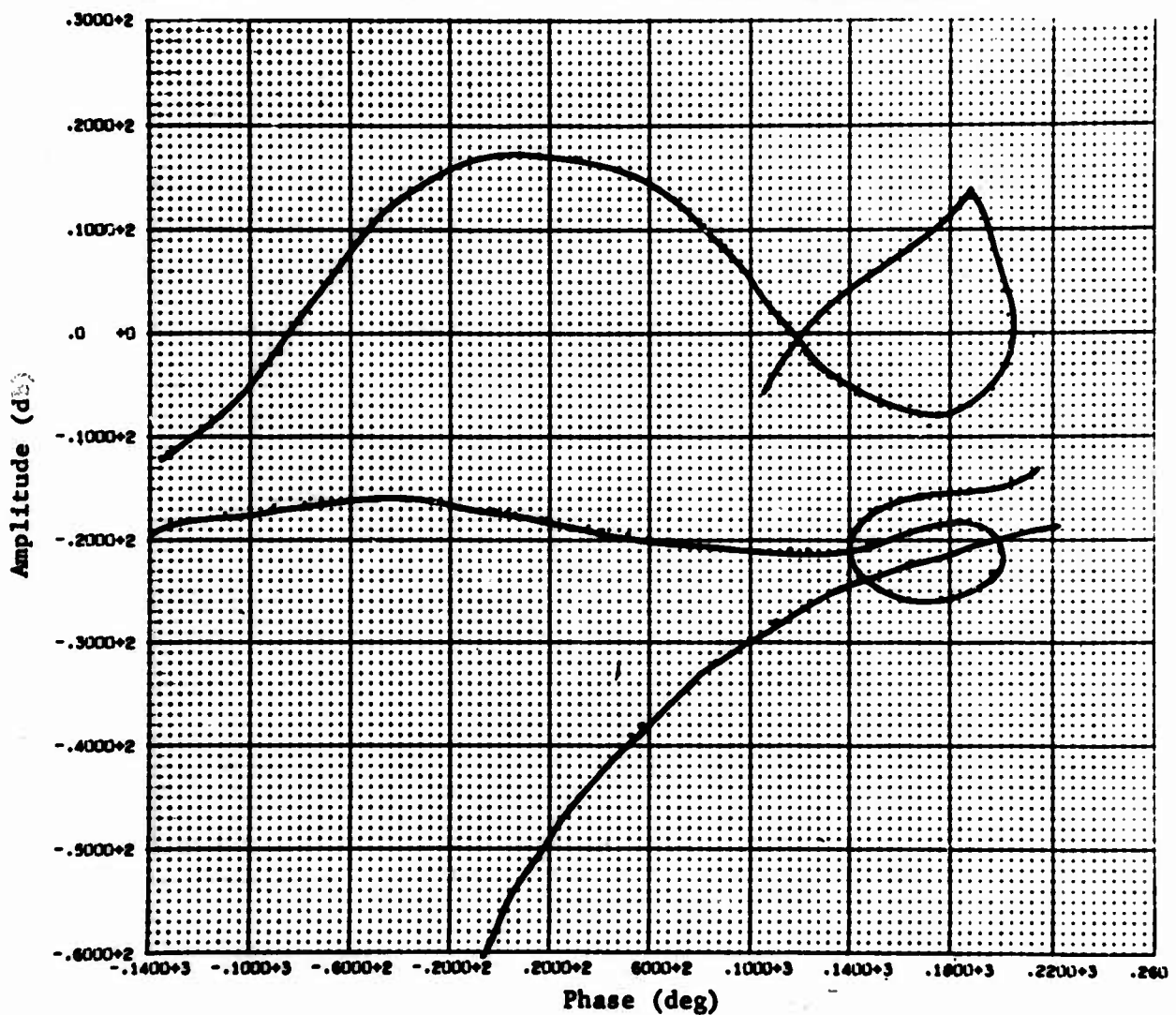

Fig. C-2 Open Loop Frequency Response, Pitch Axis (30 sec, BGC)

Flight Control System Configuration

Channel	Gain	Filter Configuration
Displacement	$K_{RD} = 2.08$	$\frac{K_{RD} 7.5}{(1 + 7.5S)(1 + S/10)}$
Stage I Rate	$K_{R1} = 0.52$	$\frac{1}{(1 + S/40)^2}$
Stage II Rate	$K_{R2} = 0.18$	$\frac{1}{(1 + \frac{S}{30})^2}$
Acceleration	$K_A = 0$	
Velocity	$K_V = 0$	

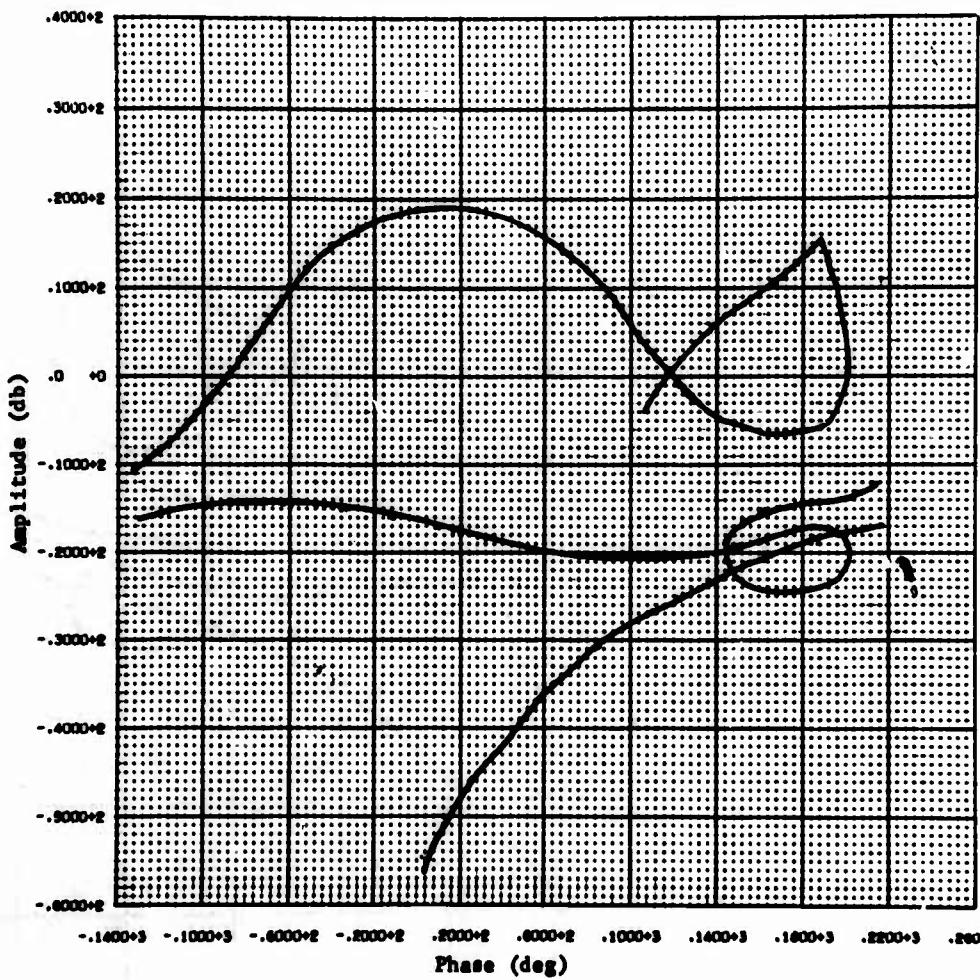

Fig. C-3 Open Loop Frequency Response, Pitch Axis (30 sec, AGC)

Flight Control System Configuration

Channel	Gain	Filter Configuration
Displacement	$K_{RD} = 2.08$	$\frac{K_{RD} 7.5}{(1 + 7.5s)(1 + s/10)}$
Stage I Rate	$K_{R1} = 0.52$	$\frac{1}{(1 + s/40)^2}$
Stage II Rate	$K_{R2} = 0.18$	$\frac{1}{(1 + \frac{s}{30})^2}$
Acceleration	$K_A = 0$	
Velocity	$K_V = 0$	

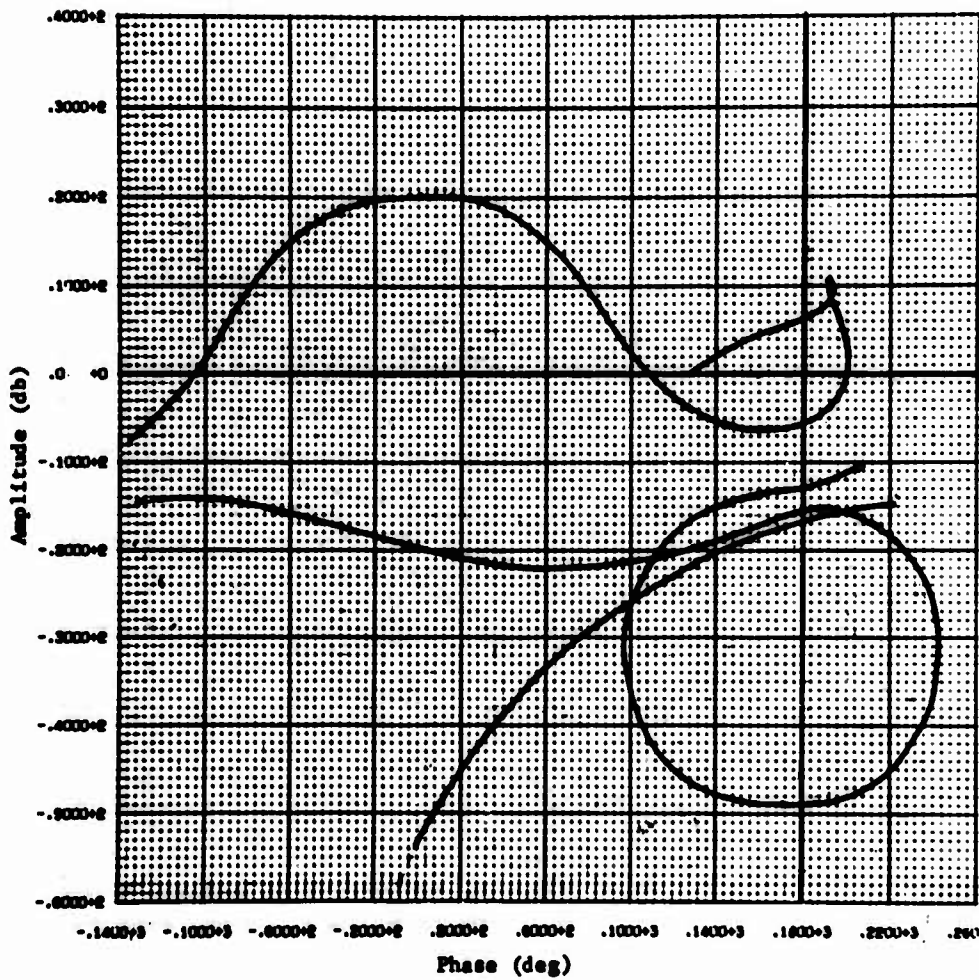

Fig. C-4 Open Loop Frequency Response, Pitch Axis (60 sec)

Flight Control System Configuration

Channel	Gain	Filter Configuration
Displacement	$K_{RD} = 2.08$	$\frac{K_{RD} 7.5}{(1 + 7.5s)(1 + s/10)}$
Stage I Rate	$K_{R1} = 0.52$	$\frac{1}{(1 + s/40)^2}$
Stage II Rate	$K_{R2} = 0.18$	$\frac{1}{(1 + \frac{s}{30})^2}$
Acceleration	$K_A = 0$	
Velocity	$K_V = 0$	

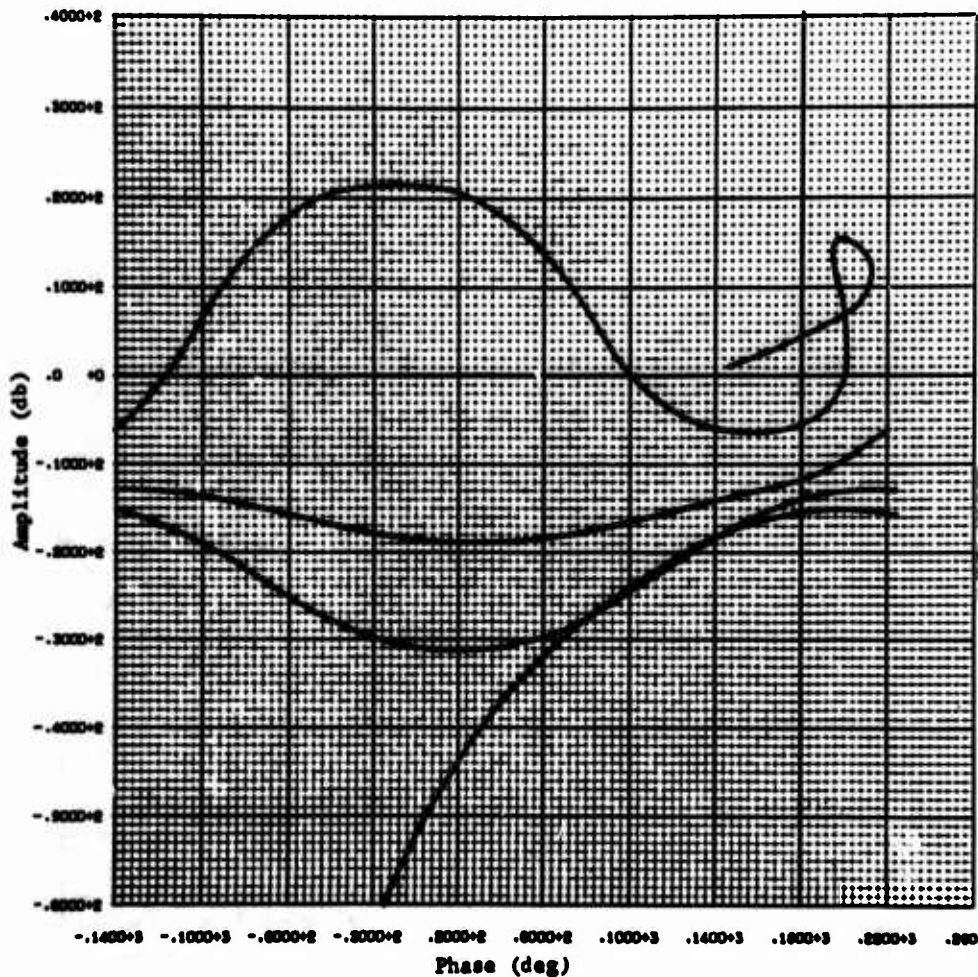

Fig. C-5 Open Loop Frequency Response, Pitch Axis (90 sec, BGC)

Flight Control System Configuration

Channel	Gain	Filter Configuration
Displacement	$K_{RD} = 1.54$	$\frac{K_{RD} 7.5}{(1 + 7.5S)(1 + S/10)}$
Stage I Rate	$K_{R1} = 0.34$	$\frac{1}{(1 + S/40)^2}$
Stage II Rate	$K_{R2} = 0.195$	$\frac{1}{(1 + S/30)^2}$
Acceleration	$K_A = 0$	
Velocity	$K_V = 0$	

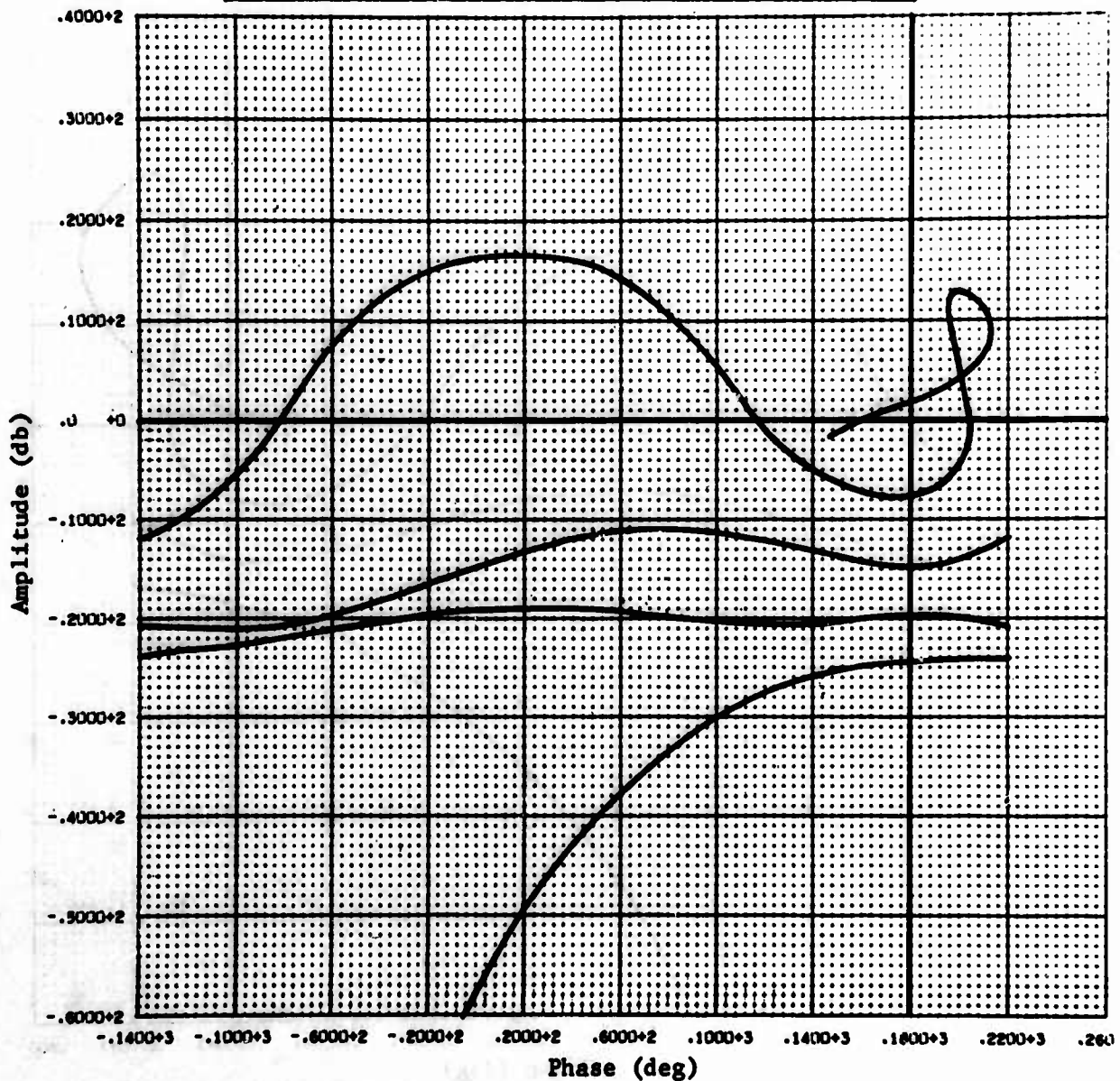

Fig. C-6 Open Loop Frequency Response, Pitch Axis (80 sec, AGC)

SSD-CR-64-32
Flight Control System Configuration

Channel	Gain	Filter Configuration
Displacement	$K_{RD} = 1.54$	$\frac{K_{RD} 7.5}{(1 + 7.5S)(1 + S/10)}$
Stage I Rate	$K_{R1} = 0.34$	$\frac{1}{(1 + S/40)^2}$
Stage II Rate	$K_{R2} = 0.195$	$\frac{1}{(1 + S/30)^2}$
Acceleration	$K_A = 0$	
Velocity	$K_V = 0$	

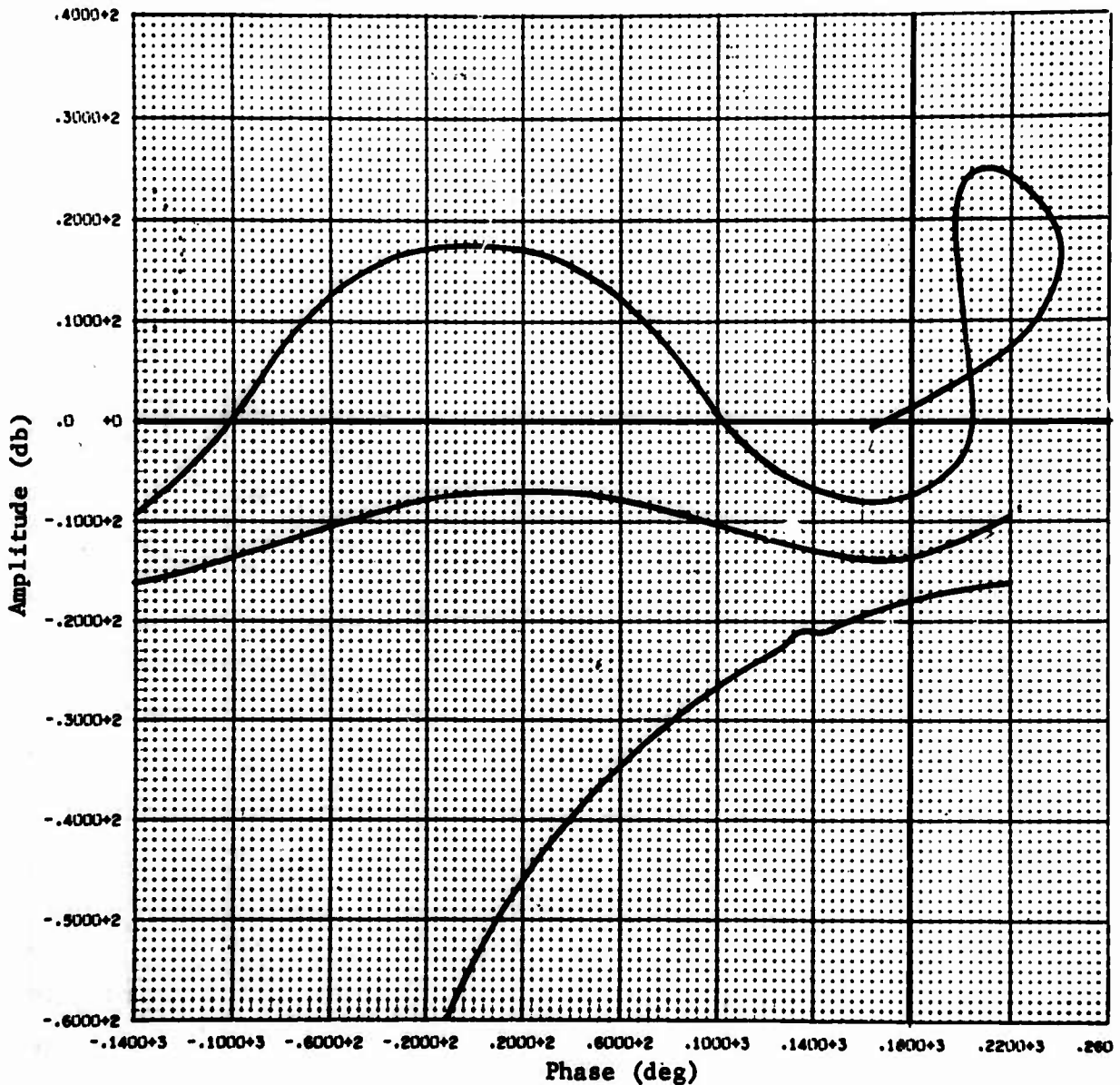

Fig. C-7 Open Loop Frequency Response, Pitch Axis (105 sec)

Flight Control System Configuration

Channel	Gain	Filter Configuration
Displacement	$K_{RD} = 1.72$	$\frac{K_{RD} 7.5}{(1 + 7.5S)(1 + S/10)}$
Stage I Rate	$K_{R1} = 0.46$	$\frac{1}{(1 + S/40)^2}$
Stage II Rate	$K_{R2} = 0.17$	$\frac{1}{(1 + S/30)^2}$
Acceleration	$K_A = 0$	
Velocity	$K_V = 0$	

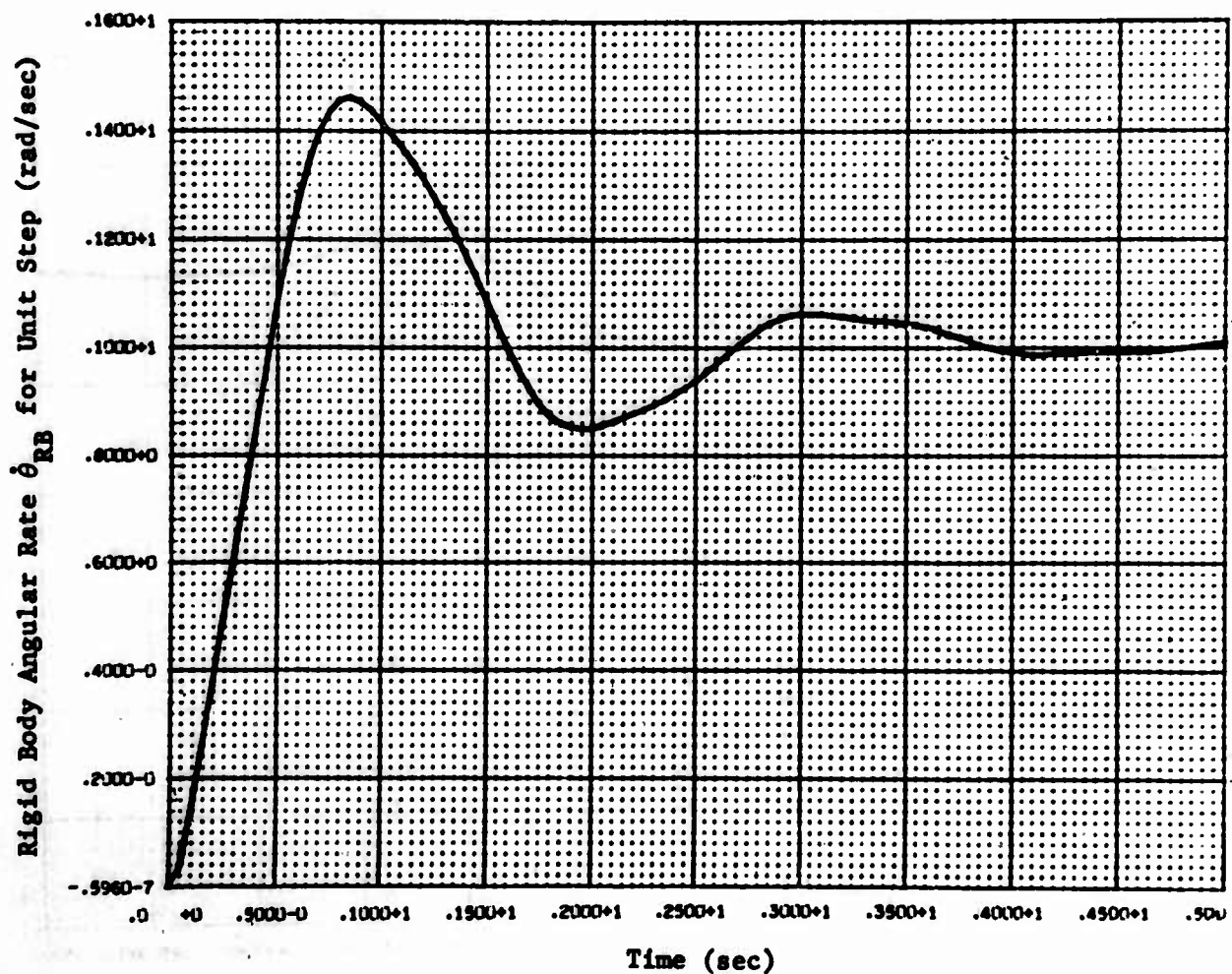

Fig. C-8 Transient Response, Pitch Axis (0 sec)

Flight Control System Configuration

Channel	Gain	Filter Configuration
Displacement	$K_{RD} = 1.72$	$\frac{K_{RD} 7.5}{(1 + 7.5S)(1 + S/10)}$
Stage I Rate	$K_{R1} = 0.46$	$\frac{1}{(1 + S/40)^2}$
Stage II Rate	$K_{R2} = 0.17$	$\frac{1}{(1 + S/30)^2}$
Acceleration	$K_A = 0$	
Velocity	$K_V = 0$	

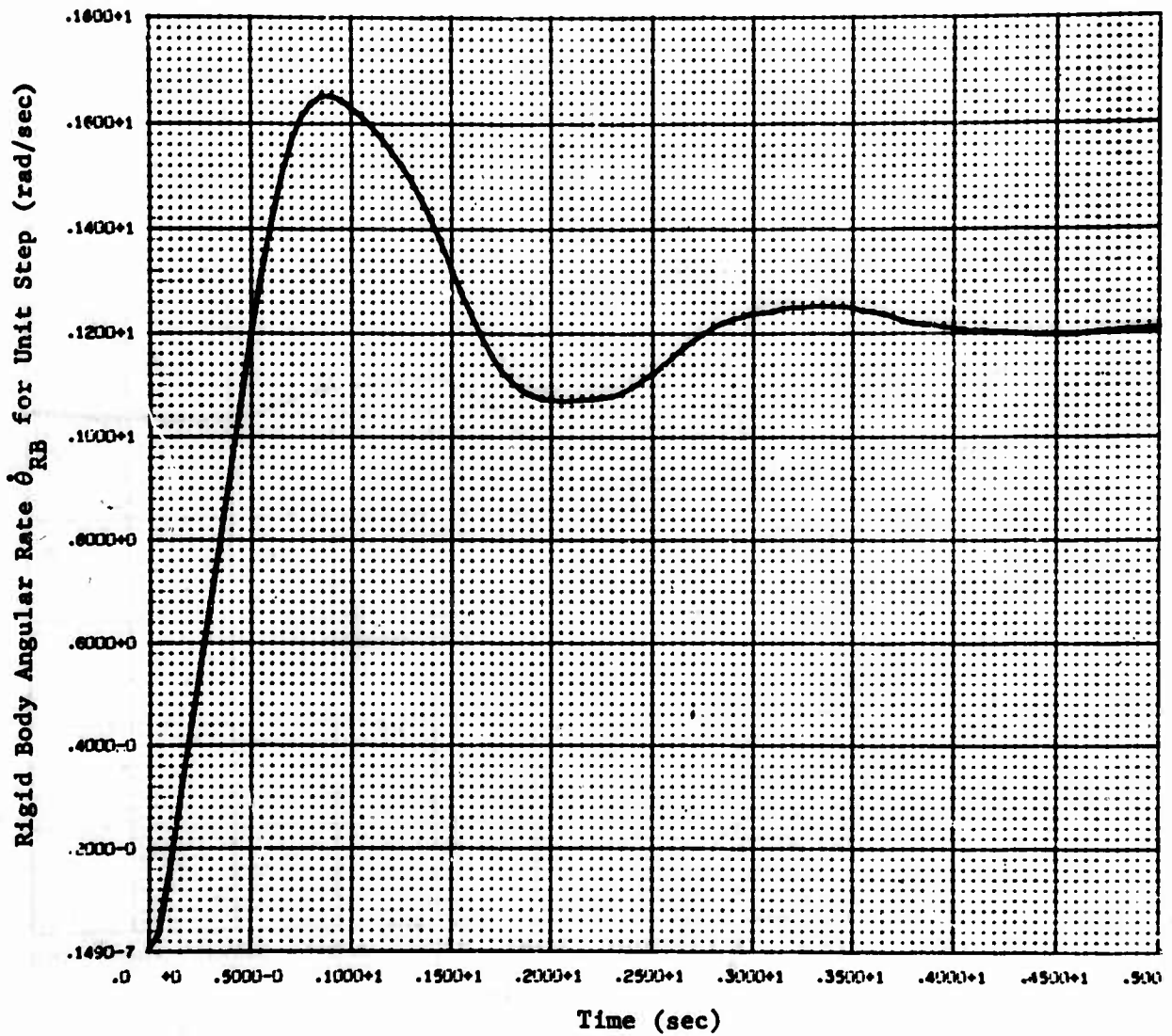

Fig. C-9 Transient Response. Pitch Axis (30 sec, BGC)

Flight Control System Configuration

Channel	Gain	Filter Configuration
Displacement	$K_{RD} = 2.08$	$\frac{K_{RD} 7.5}{(1 + 7.5S)(1 + S/10)}$
Stage I Rate	$K_{R1} = 0.52$	$\frac{1}{(1 + S/40)^2}$
Stage II Rate	$K_{R2} = 0.18$	$\frac{1}{(1 + S/30)^2}$
Acceleration	$K_A = 0$	
Velocity	$K_V = 0$	

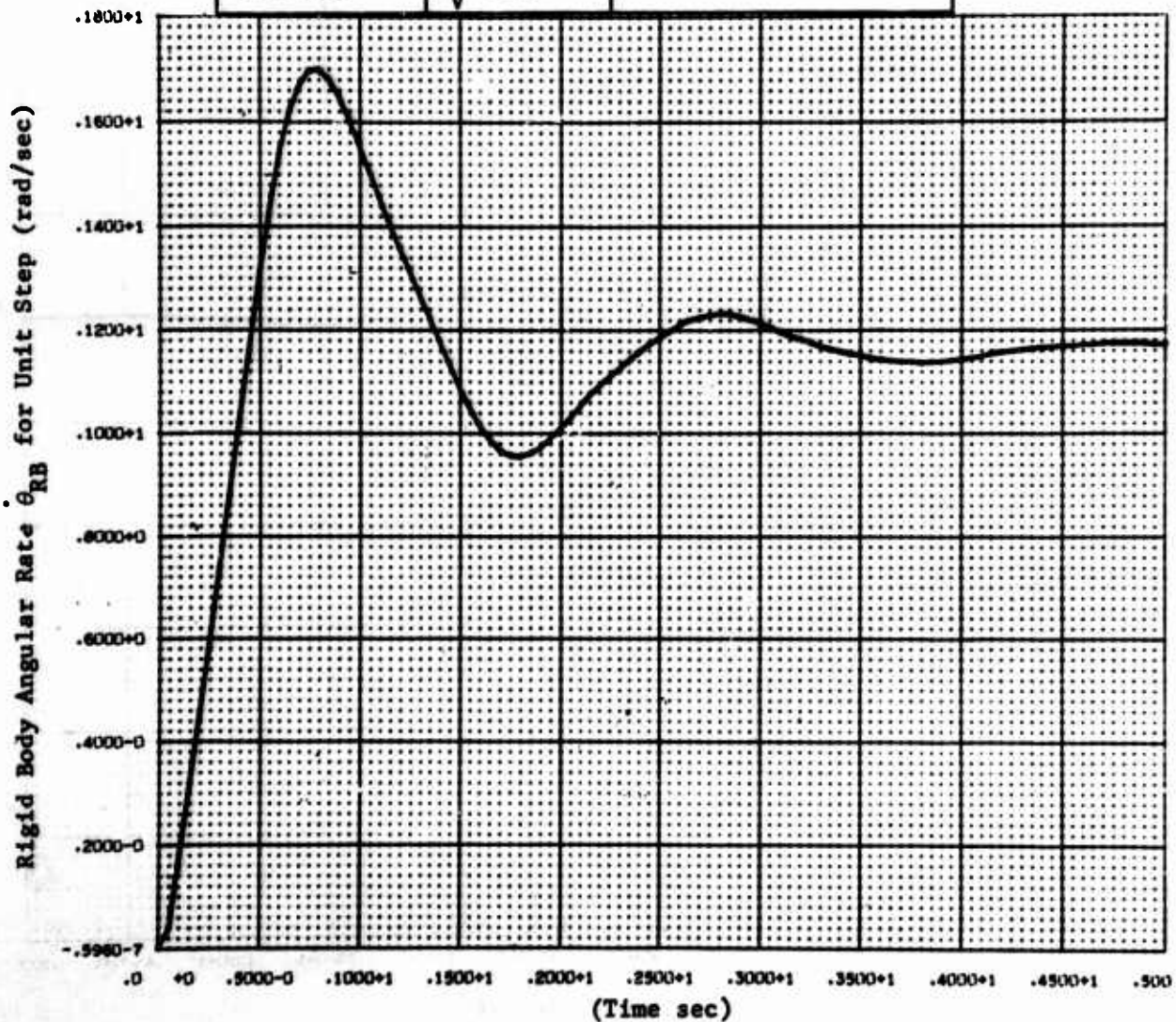

Fig. C-10 Transient Response, Pitch Axis (30 sec, AGC)

Flight Control System Configuration

Channel	Gain	Filter Configuration
Displacement	$K_{RD} = 2.08$	$\frac{K_{RD} 7.5}{(1 + 7.5S)(1 + S/10)}$
Stage I Rate	$K_{R1} = 0.52$	$\frac{1}{(1 + S/40)^2}$
Stage II Rate	$K_{R2} = 0.18$	$\frac{1}{(1 + S/30)^2}$
Acceleration	$K_A = 0$	
Velocity	$K_V = 0$	

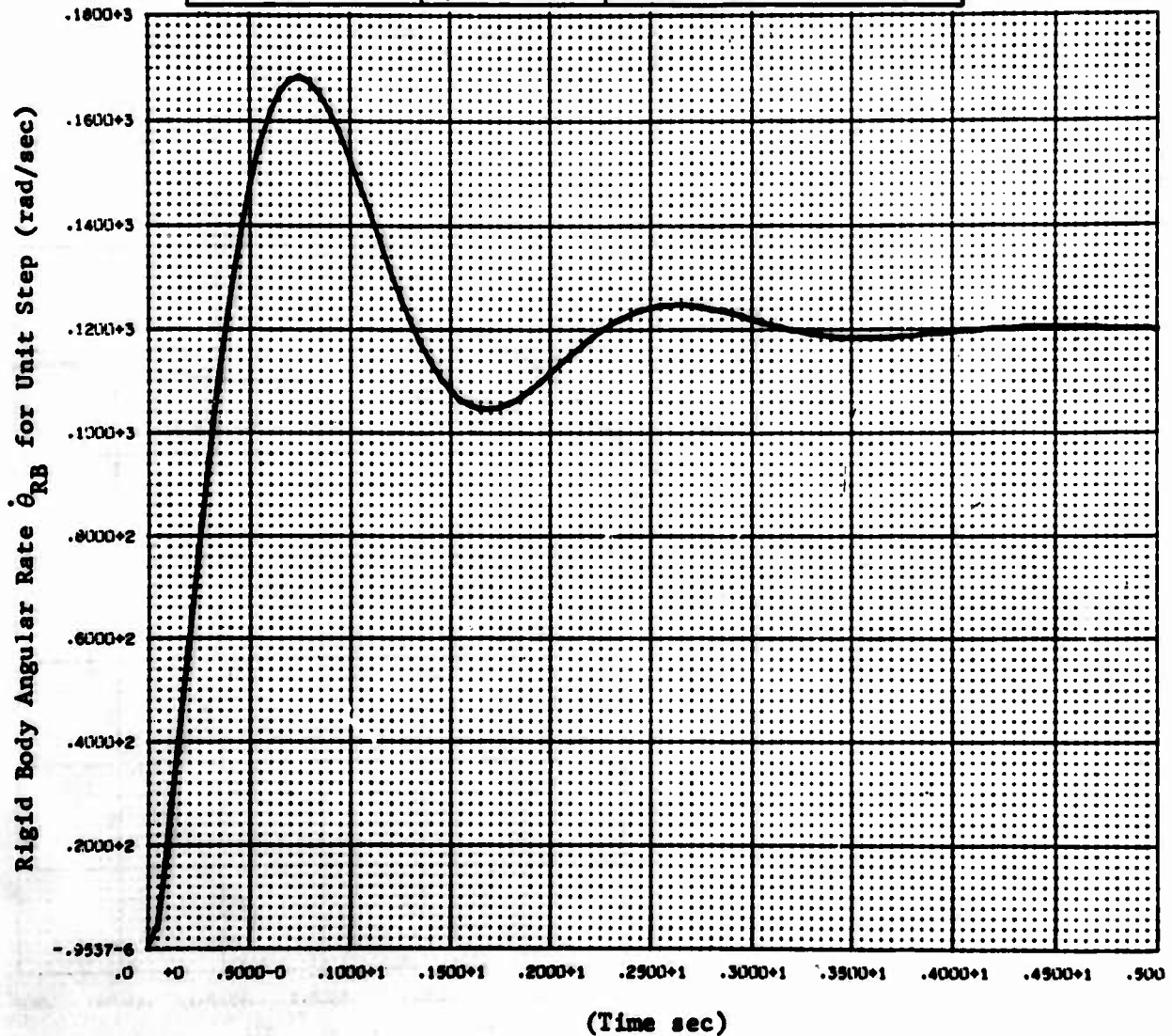

Fig. C-11 Transient Response, Pitch Axis (60 sec)

Flight Control System Configuration

Channel	Gain	Filter Configuration
Displacement	$K_{RD} = 2.08$	$\frac{K_{RD} 7.5}{(1 + 7.5S)(1 + S/10)}$
Stage I Rate	$K_{R1} = 0.52$	$\frac{1}{(1 + S/40)^2}$
Stage II Rate	$K_{R2} = 0.18$	$\frac{1}{(1 + S/30)^2}$
Acceleration	$K_A = 0$	
Velocity	$K_V = 0$	

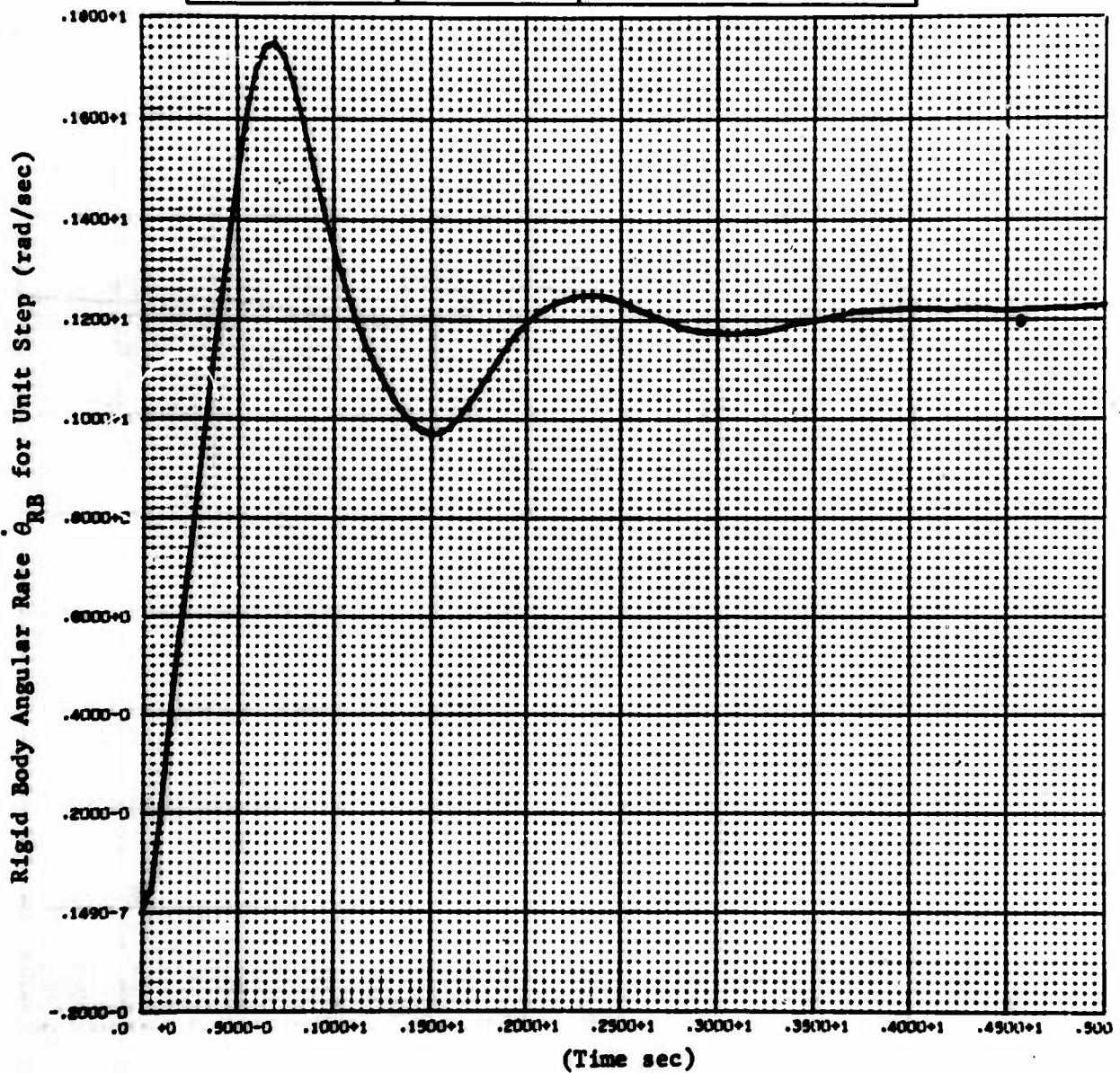

Fig. C-12 Transient Response, Pitch Axis (80 sec, BGC)

SSD-CR-64-32
Flight Control System Configuration

Channel	Gain	Filter Configuration
Displacement	$K_{RD} = 1.54$	$\frac{K_{RD} 7.5}{(1+7.5S)(1+S/10)}$
Stage I Rate	$K_{R1} = 0.34$	$\frac{1}{(1 + S/40)^2}$
Stage II Rate	$K_{R2} = 0.195$	$\frac{1}{(1 + S/30)}$
Acceleration	$K_A = 0$	
Velocity	$K_V = 0$	

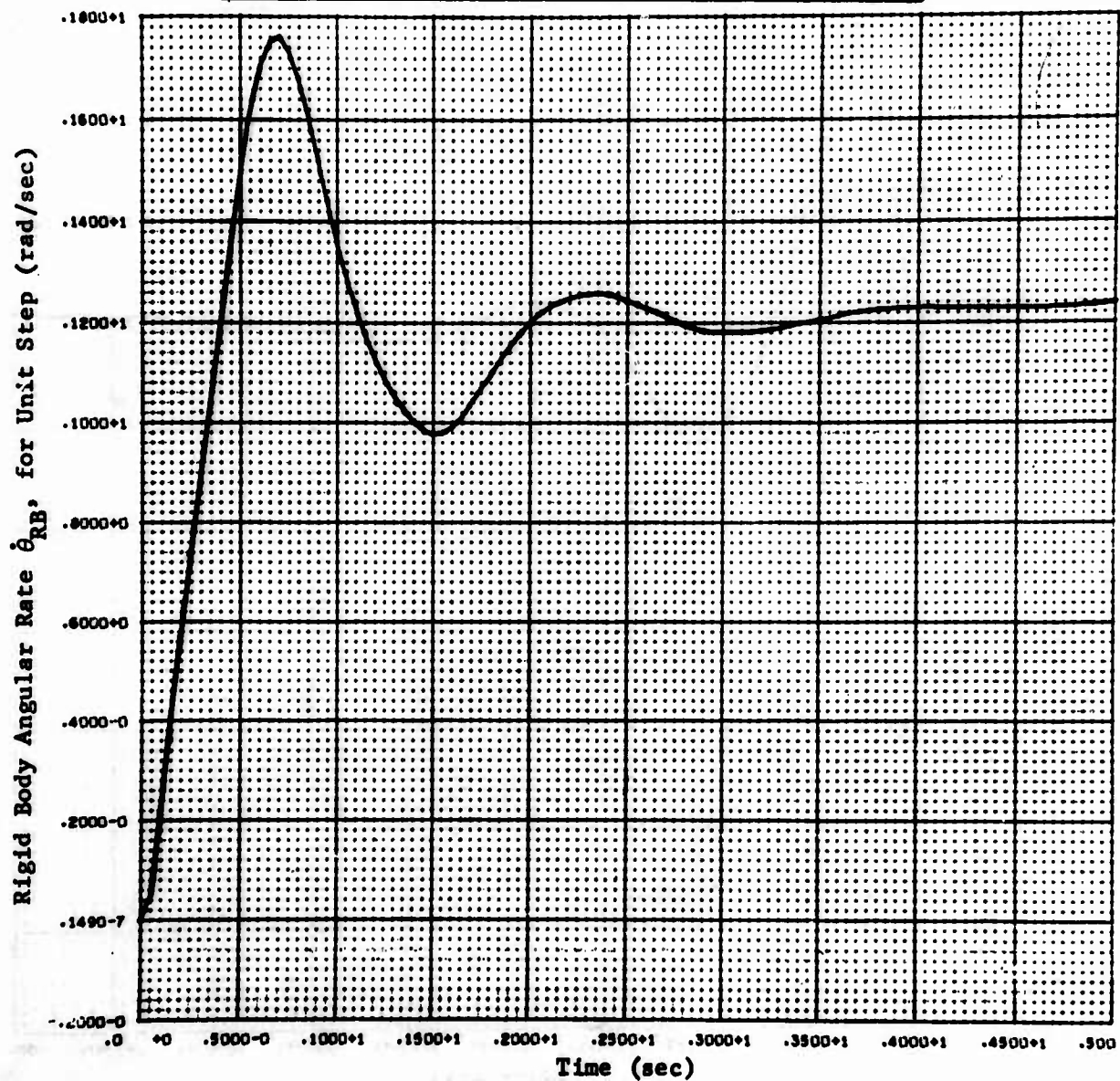

Fig. C-13 Transient Response, Pitch Axis (80 sec, AGC)

Flight Control System Configuration

Channel	Gain	Filter Configuration
Displacement	$K_{RD} = 1.54$	$\frac{K_{RD} 7.5}{(1+7.5s)(1+s/10)}$
Stage I Rate	$K_{R1} = 0.34$	$\frac{1}{(1 + s/40)^2}$
Stage II Rate	$K_{R2} = 0.195$	$\frac{1}{(1 + s/30)^2}$
Acceleration	$K_A = 0$	
Velocity	$K_V = 0$	

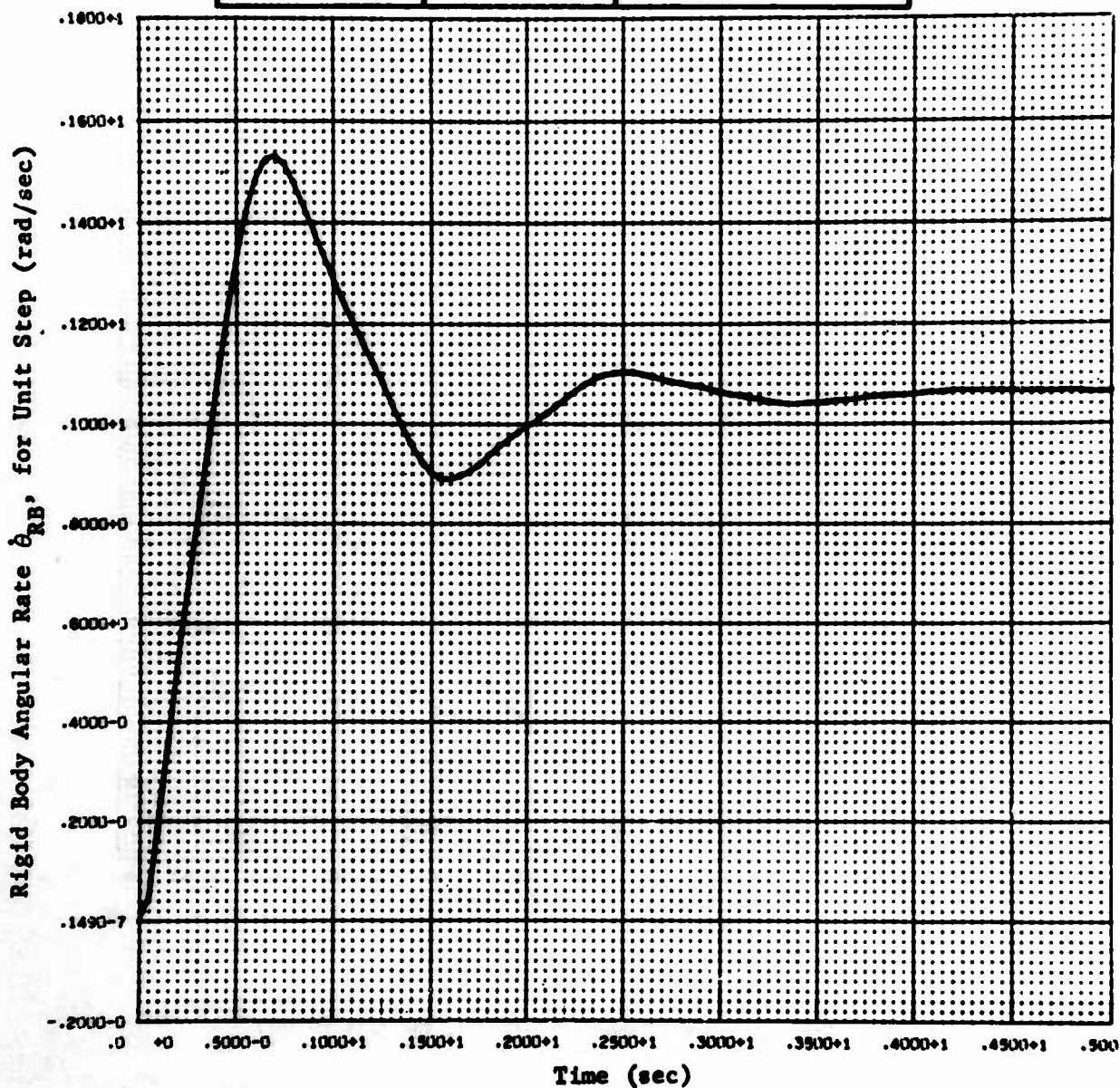

Fig. C-14 Transient Response, Pitch Axis (105 sec)

Flight Control System Configuration

Channel	Gain	Filter Configuration
Stage I Rate	$K_{R1} = 0.3$	$\frac{1}{(1 + s/15)^2}$
Stage II Rate	$K_{R2} = 0.25$	$\frac{1}{(1 + s/15)^2}$
Acceleration	$K_A = 0$	
Velocity	$K_V = 0$	
Displacement	$K_{RD} = 1.68$	$\frac{K_{RD} 7.5}{(1 + 7.5s)(1 + s/5)}$

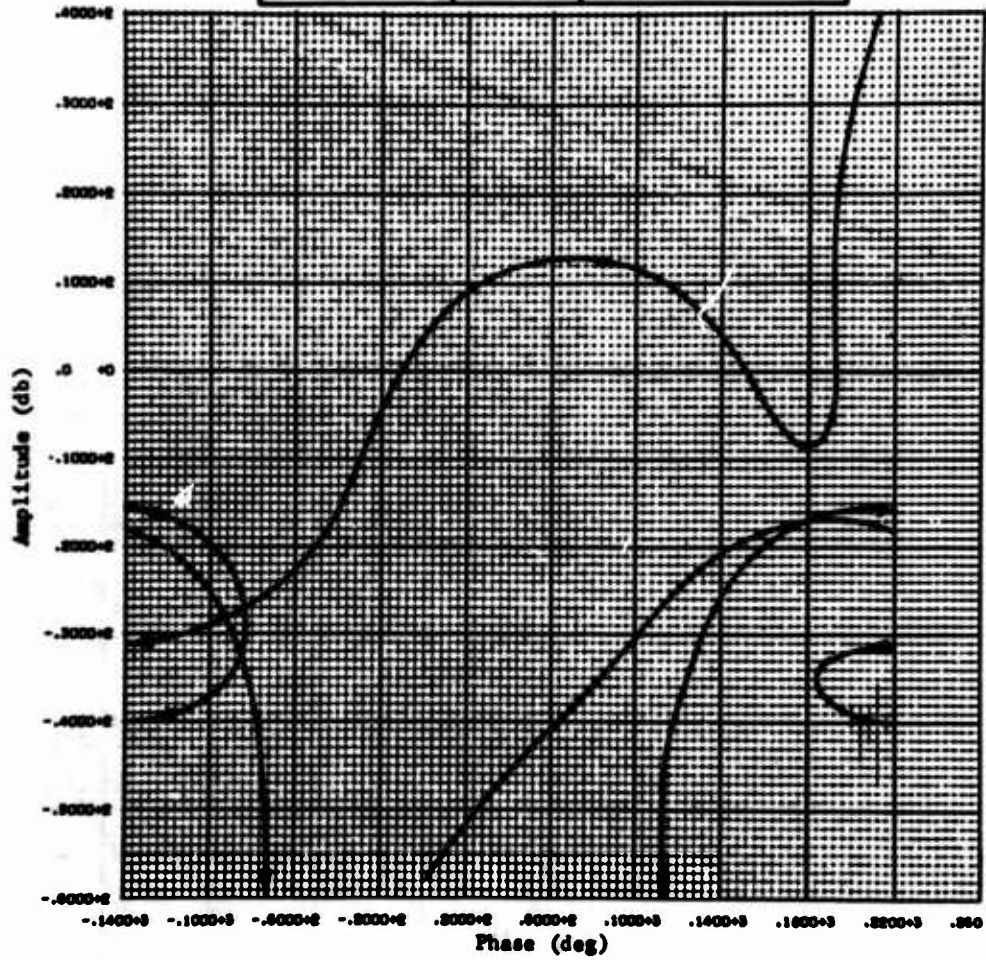

Fig. C-15 Open Loop Frequency Response, Yaw Axis (0 sec)

Flight Control System Configuration

Channel	Gain	Filter Configuration
Stage I Rate	$K_{R1} = 0.3$	$\frac{1}{(1 + s/15)^2}$
Stage II Rate	$K_{R2} = 0.25$	$\frac{1}{(1 + s/15)^2}$
Acceleration	$K_A = 0$	
Velocity	$K_V = 0$	
Displacement	$K_{RD} = 1.68$	$\frac{K_{RD} (7.5)}{(1 + 7.5s)(1 + s/5)}$

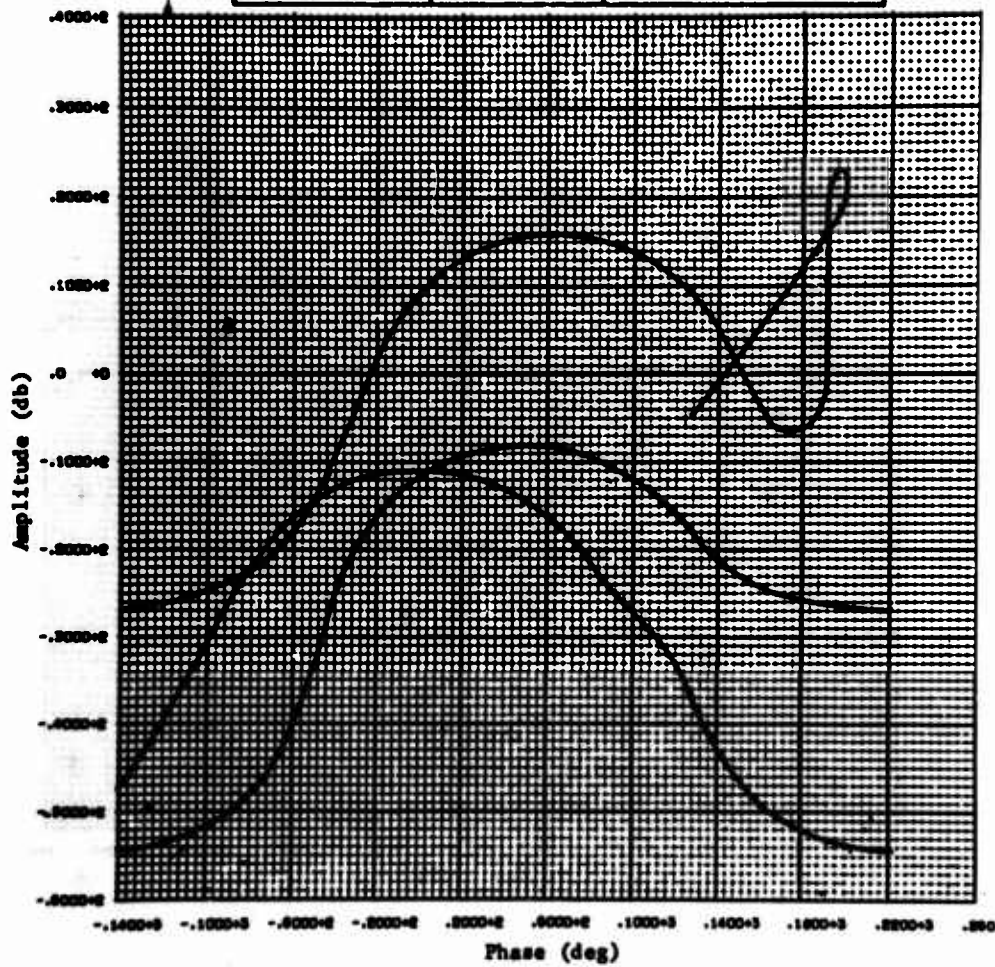

Fig. C-16 Open Loop Frequency Response, Yaw Axis (30 sec, BGC)

Flight Control System Configuration

Channel	Gain	Filter Configuration
Stage I Rate	$K_{R1} = 0.38$	$\frac{1}{(1 + s/15)^2}$
Stage II Rate	$K_{R2} = 0.25$	$\frac{1}{(1 + s/15)^2}$
Acceleration	$K_A = 0$	
Velocity	$K_V = 0$	
Displacement	$K_{RD} = 1.45$	$\frac{K_{RD} (7.5)}{(1 + 7.5s)(1 + s/5)}$

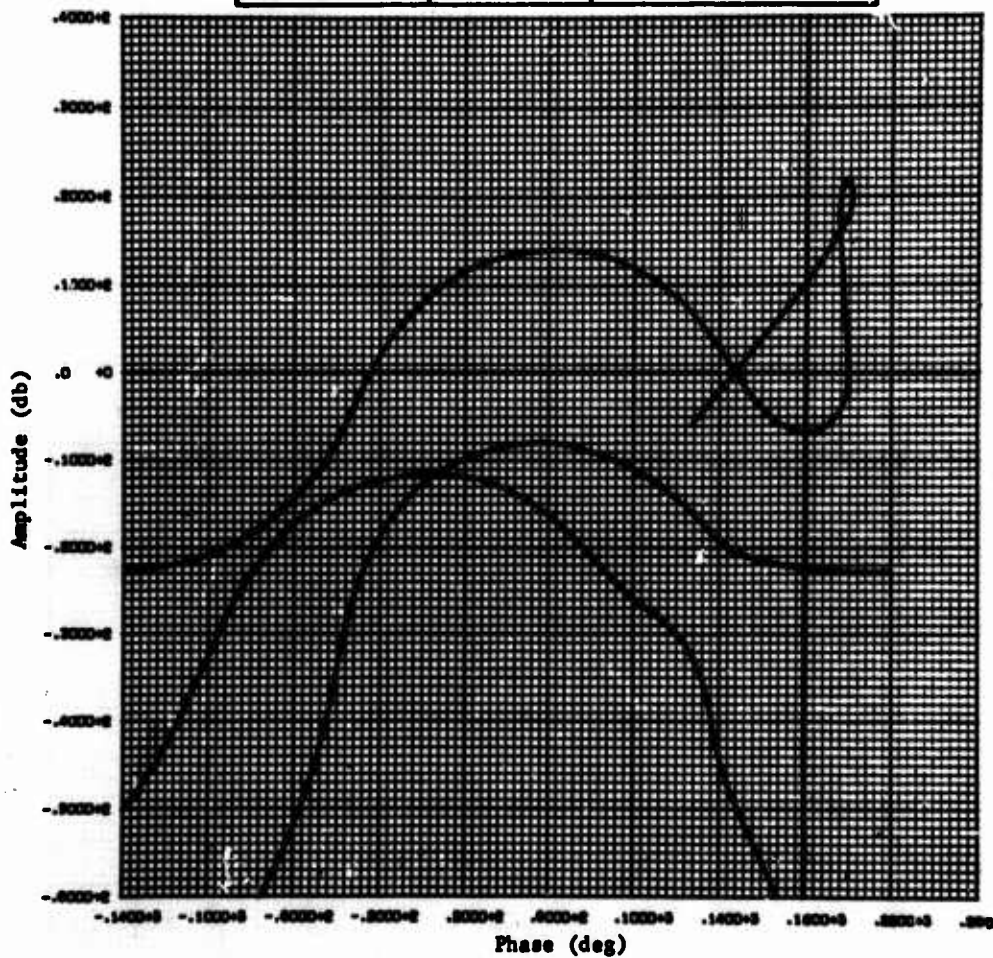

Fig. C-17 Open Loop Frequency Response, Yaw Axis (30 sec, AGC)

Flight Control System Configuration

Channel	Gain	Filter Configuration
Stage I Rate	$K_{R1} = 0.38$	$\frac{1}{(1 + s/15)^2}$
Stage II Rate	$K_{R2} = 0.25$	$\frac{1}{(1 + s/15)^2}$
Acceleration	$K_A = 0$	
Velocity	$K_V = 0$	
Displacement	$K_{RD} = 1.45$	$\frac{K_D (7.5)}{(1 + 7.5s)(1 + s/5)}$

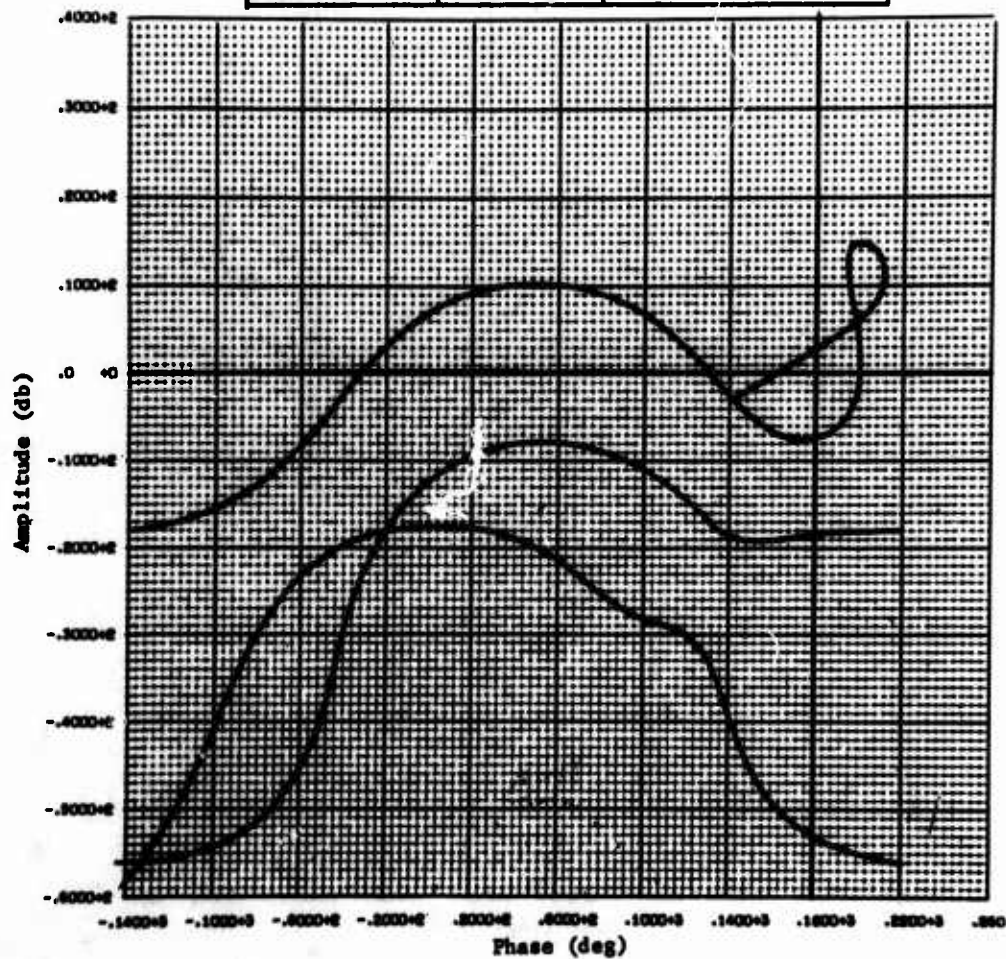

Fig. C-18 Open Loop Frequency Response, Yaw Axis (60 sec)

Flight Control System Configuration

Channel	Gain	Filter Configuration
Stage I Rate	$K_{R1} = 0.38$	$\frac{1}{(1 + s/15)^2}$
Stage II Rate	$K_{R2} = 0.25$	$\frac{1}{(1 + s/15)^2}$
Acceleration	$K_A = 0$	
Velocity	$K_V = 0$	
Displacement	$K_{RD} = 1.45$	$\frac{K_{RD} (7.5)}{(1 + 7.5s)(1 + s/5)}$

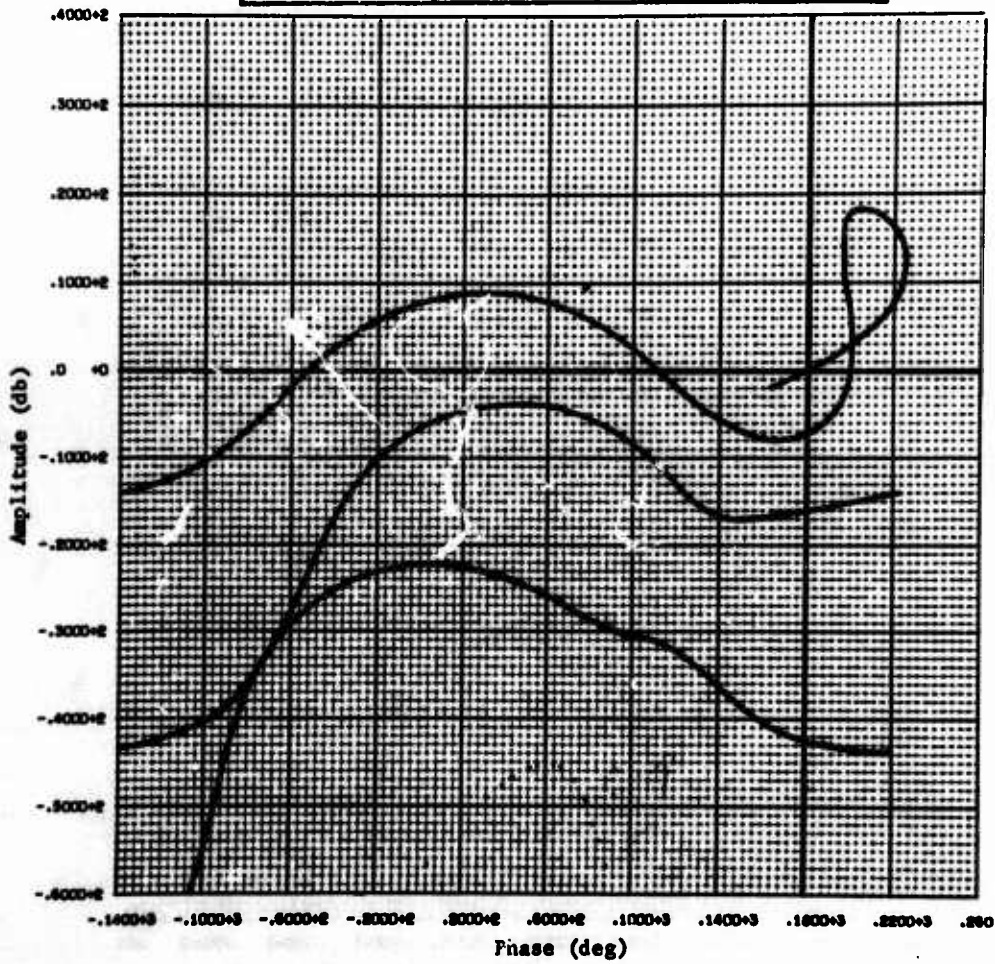

Fig. C-19 Open Loop Frequency Response, Yaw Axis (80 sec, BGC)

Flight Control System Configuration

Channel	Gain	Filter Configuration
Stage I Rate	$K_{R1} = 0.48$	$\frac{1}{(1 + S/15)^2}$
Stage II Rate	$K_{R2} = 0.32$	$\frac{1}{(1 + S/15)^2}$
Acceleration	$K_A = 0$	
Velocity	$K_V = 0$	
Displacement	$K_{RD} = 2.44$	$\frac{K_{RD} (7.5)}{(1 + 7.5S)(1 + S/5)^2}$

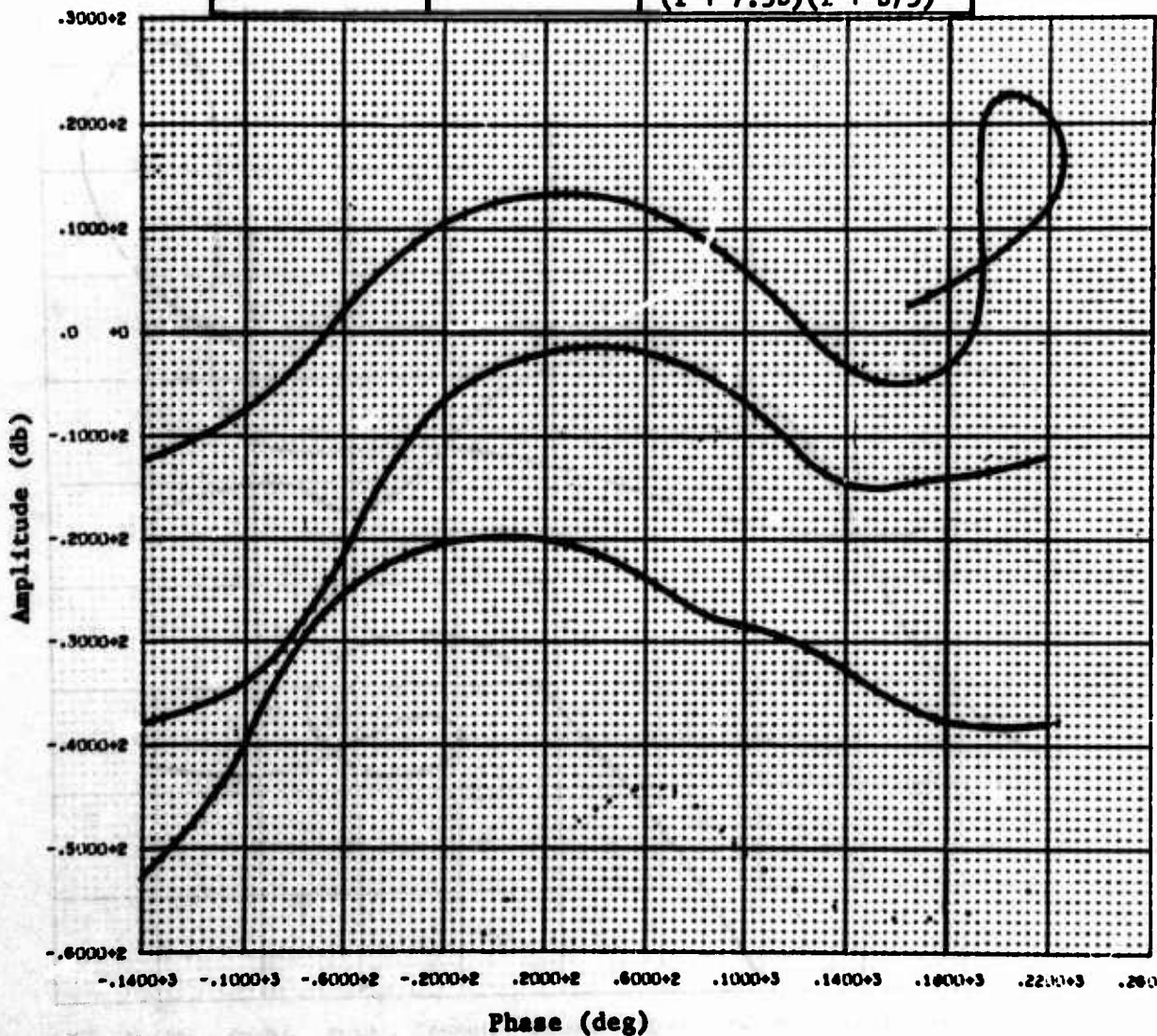

Fig. C-20 Open Loop Frequency Response, Yaw Axis (80 sec, AGC)

Flight Control System Configuration

Channel	Gain	Filter Configuration
Stage I Rate	$K_{R1} = 0.48$	$\frac{1}{(1 + s/15)^2}$
Stage II Rate	$K_{R2} = 0.32$	$\frac{1}{(1 + s/15)^2}$
Acceleration	$K_A = 0$	
Velocity	$K_V = 0$	
Displacement	$K_{RD} = 2.44$	$\frac{K_{RD} (7.5)}{(1 + 7.5s)(1 + s/5)^2}$

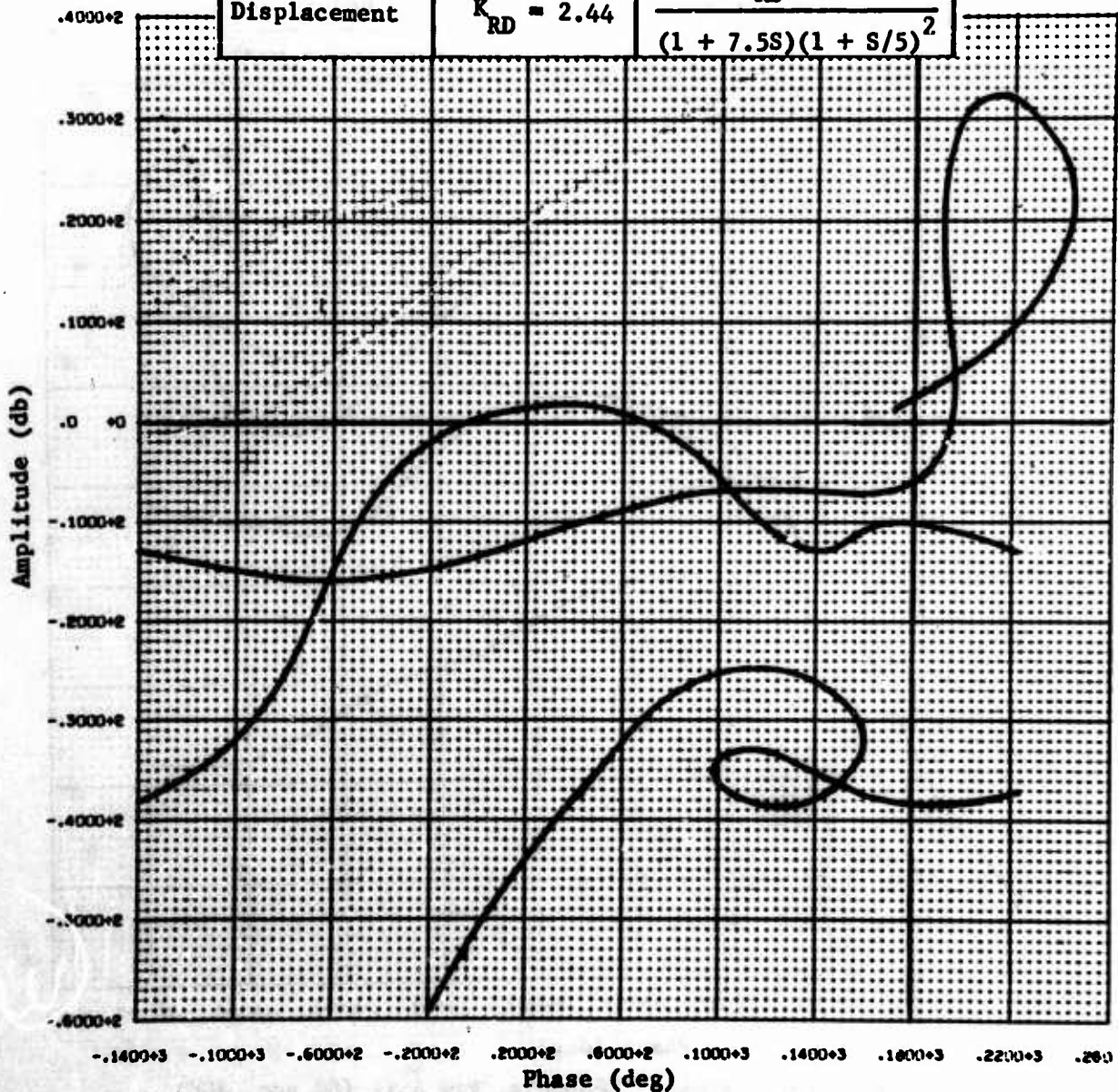

Fig. C-21 Open Loop Frequency Response, Yaw Axis (105 sec)

Flight Control System Configuration

Channel	Gain	Filter Configuration
Stage I Rate	$K_{R1} = 0.30$	$\frac{1}{(1 + s/15)^2}$
Stage II Rate	$K_{R2} = 0.25$	$\frac{1}{(1 + s/15)^2}$
Acceleration	$K_A = 0$	
Velocity	$K_V =$	
Displacement	$K_{RD} = 1.68$	$\frac{K_{RD} 7.5}{(1 + 7.5s)(1 + s/5)}$

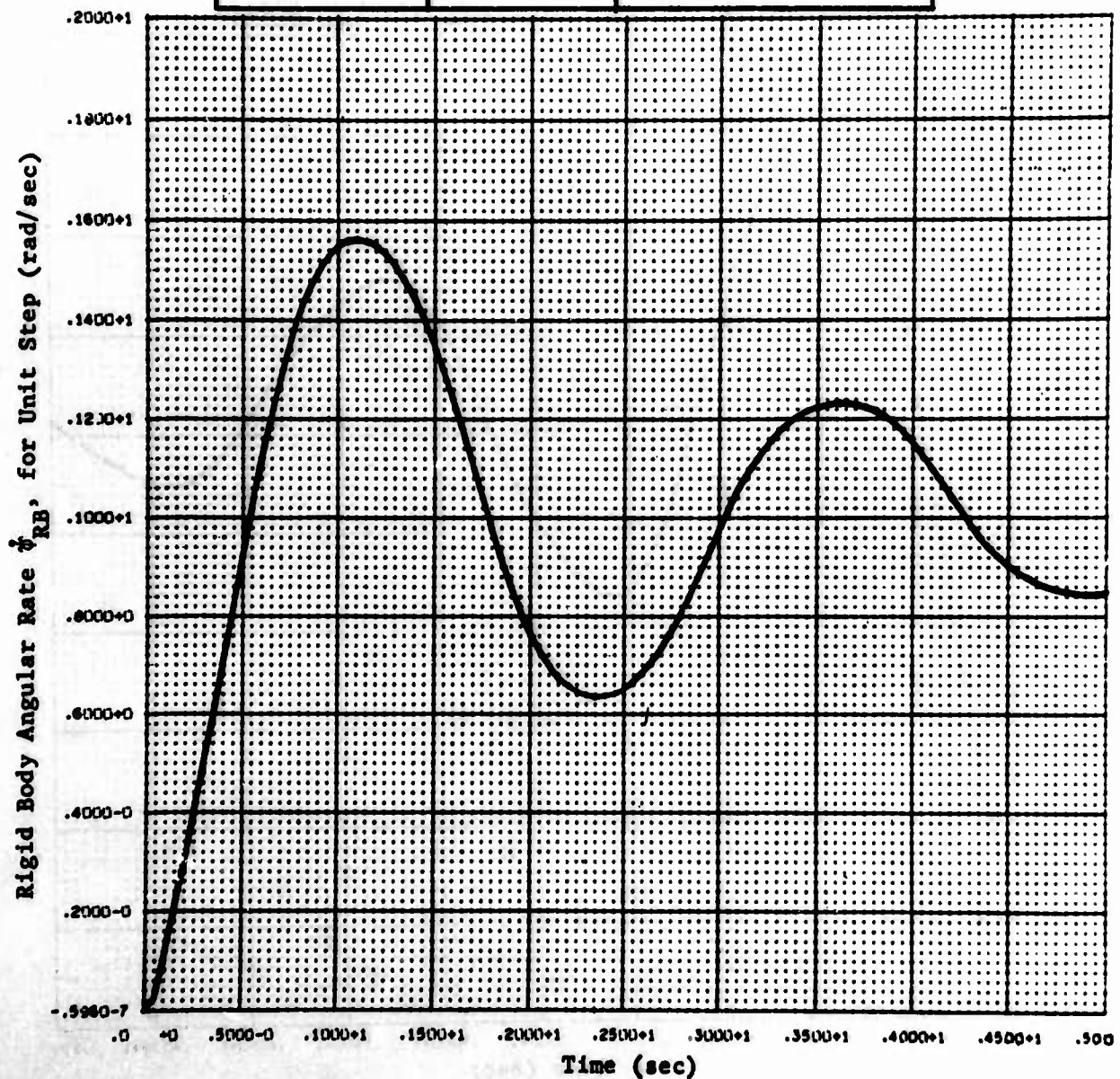

Fig. C-22 Transient Response, Yaw Axis (0 sec)

Flight Control System Configuration

Channel	Gain	Filter Configuration
Stage I Rate	$K_{R1} = 0.30$	$\frac{1}{(1 + S/15)^2}$
Stage II Rate	$K_{R11} = 0.25$	$\frac{1}{(1 + S/15)^2}$
Acceleration	$K_A = 0$	
Velocity	$K_V = 0$	
Displacement	$K_{RD} = 1.68$	$\frac{K_{RD} 7.5}{(1 + 7.5S)(1 + S/5)}$

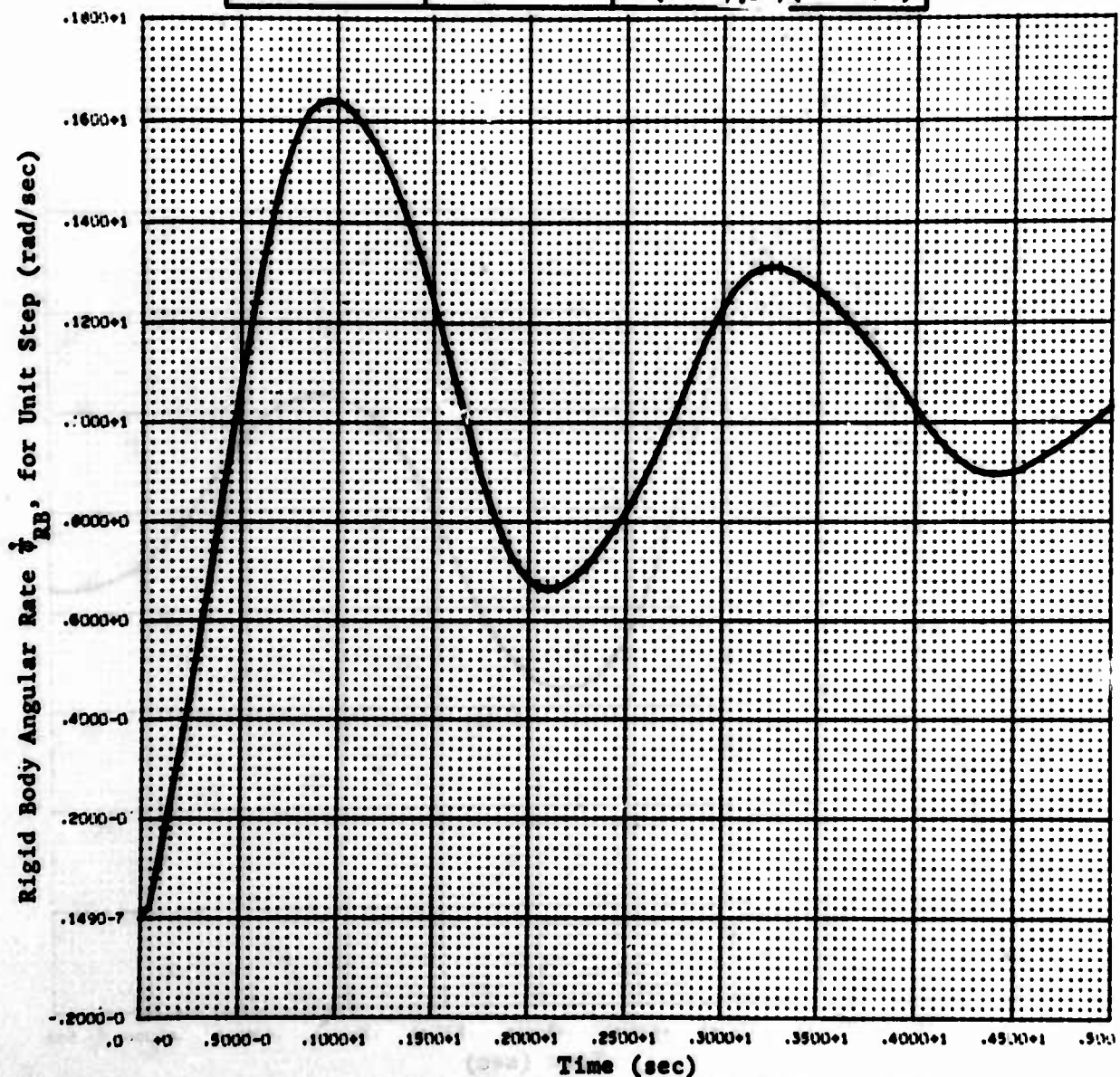

Fig. C-23 Transient Response, Yaw Axis (30 sec, BGC)

Flight Control System Configuration

Channel	Gain	Filter Configuration
Stage I Rate	$K_{R1} = 0.30$	$\frac{1}{(1 + s/15)^2}$
Stage II Rate	$K_{R2} = 0.25$	$\frac{1}{(1 + s/15)^2}$
Acceleration	$K_A = 0$	
Velocity	$K_V =$	
Displacement	$K_{RD} = 1.68$	$\frac{K_{RD} 7.5}{(1 + 7.5s)(1 + s/5)}$

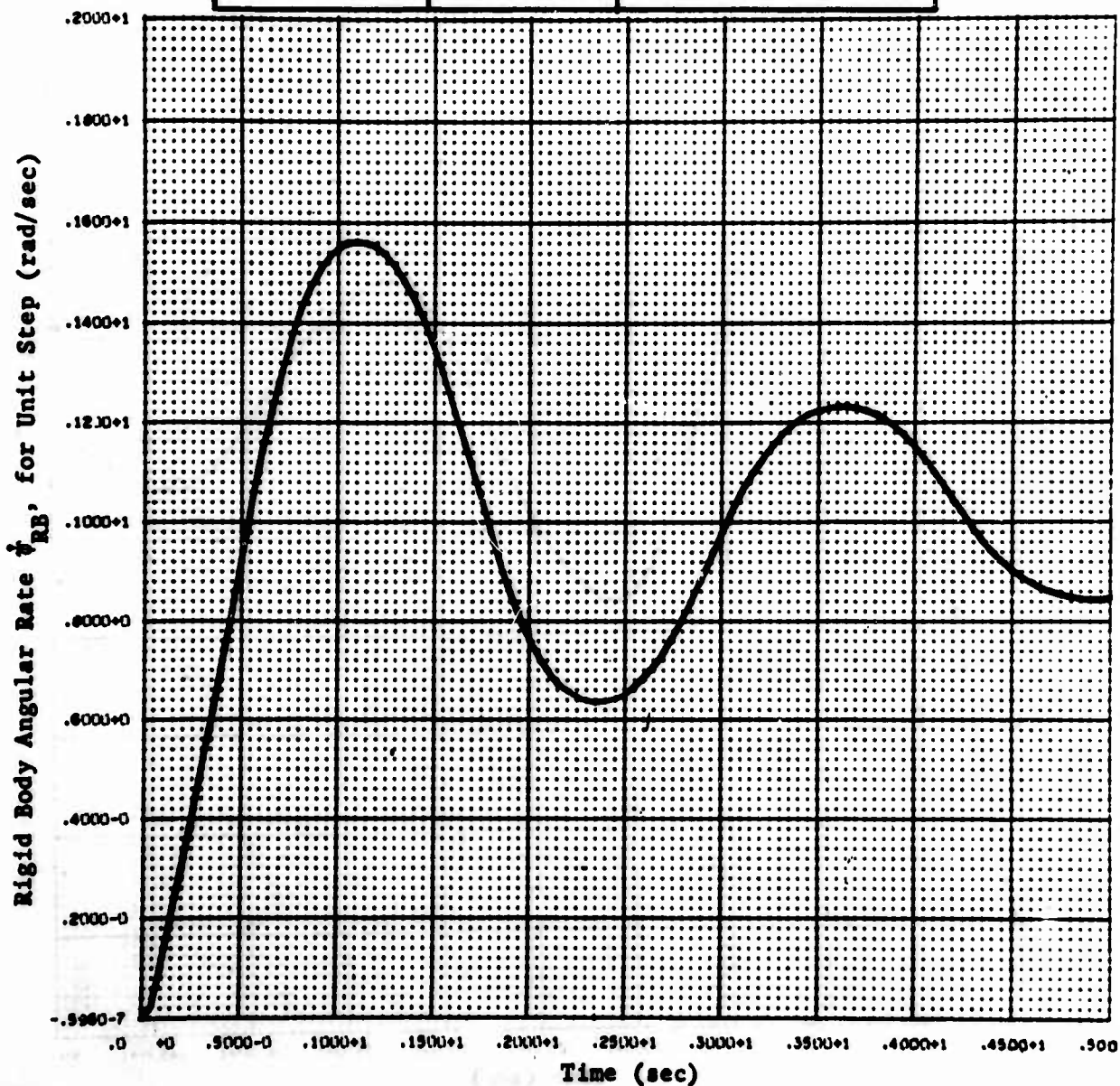

Fig. C-22 Transient Response, Yaw Axis (0 sec)

Flight Control System Configuration

Channel	Gain	Filter Configuration
Stage I Rate	$K_{R1} = 0.30$	$\frac{1}{(1 + s/15)^2}$
Stage II Rate	$K_{R11} = 0.25$	$\frac{1}{(1 + s/15)^2}$
Acceleration	$K_A = 0$	
Velocity	$K_V = 0$	
Displacement	$K_{RD} = 1.68$	$\frac{K_{RD} 7.5}{(1 + 7.5s)(1 + s/5)}$

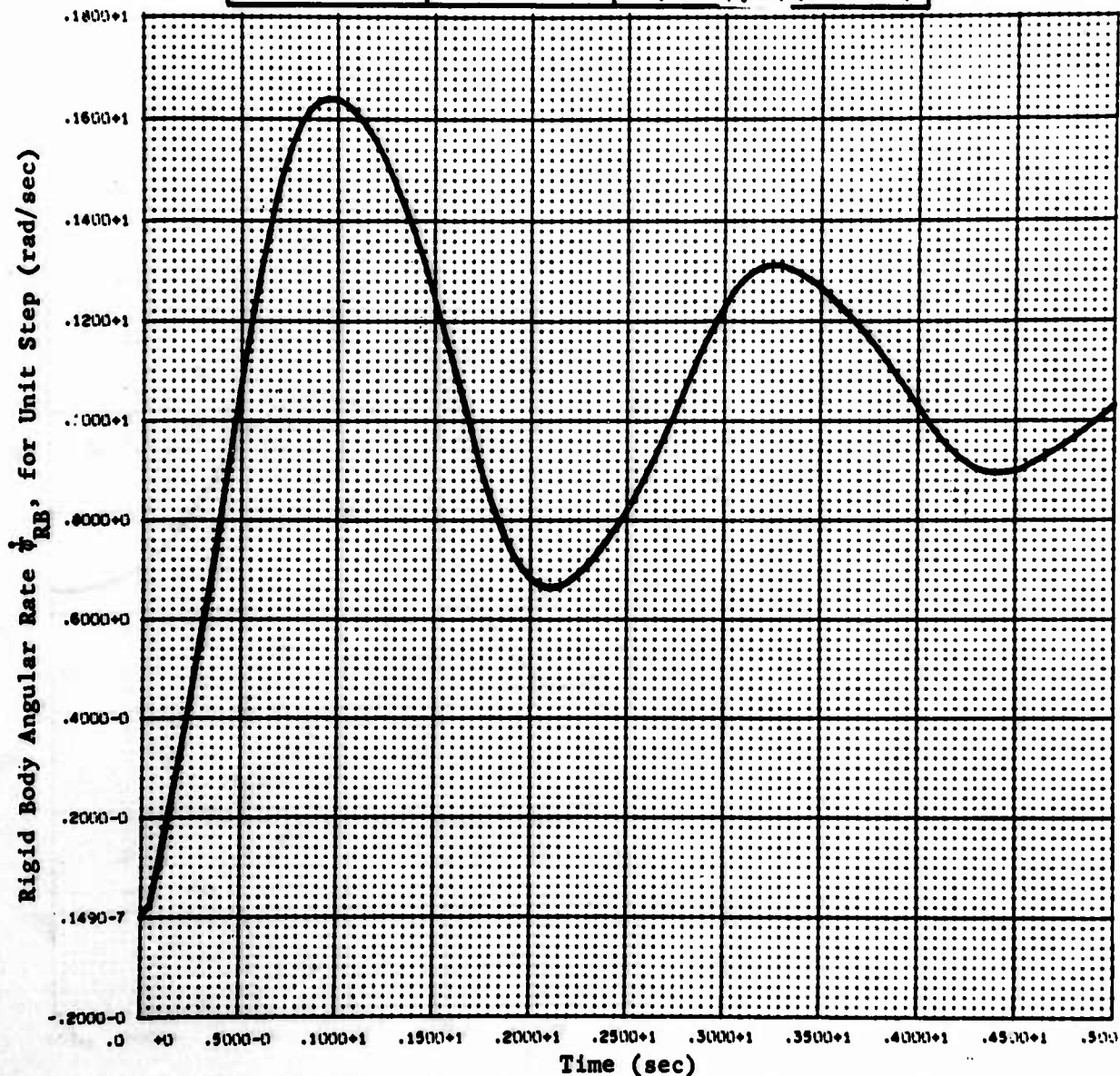

Fig. C-23 Transient Response, Yaw Axis (30 sec, BGC)

SSD-CR-64-32

Flight Control System Configuration

Channel	Gain	Filter Configuration
Stage I Rate	$K_{R1} = 0.38$	$\frac{1}{(1 + s/15)^2}$
Stage II Rate	$K_{R2} = 0.25$	$\frac{1}{(1 + s/15)^2}$
Acceleration	$K_A = 0$	
Velocity	$K_V = 0$	
Displacement	$K_{RD} = 1.45$	$\frac{K_{RD}(7.5)}{(1 + 7.5s)(1 + s/5)}$

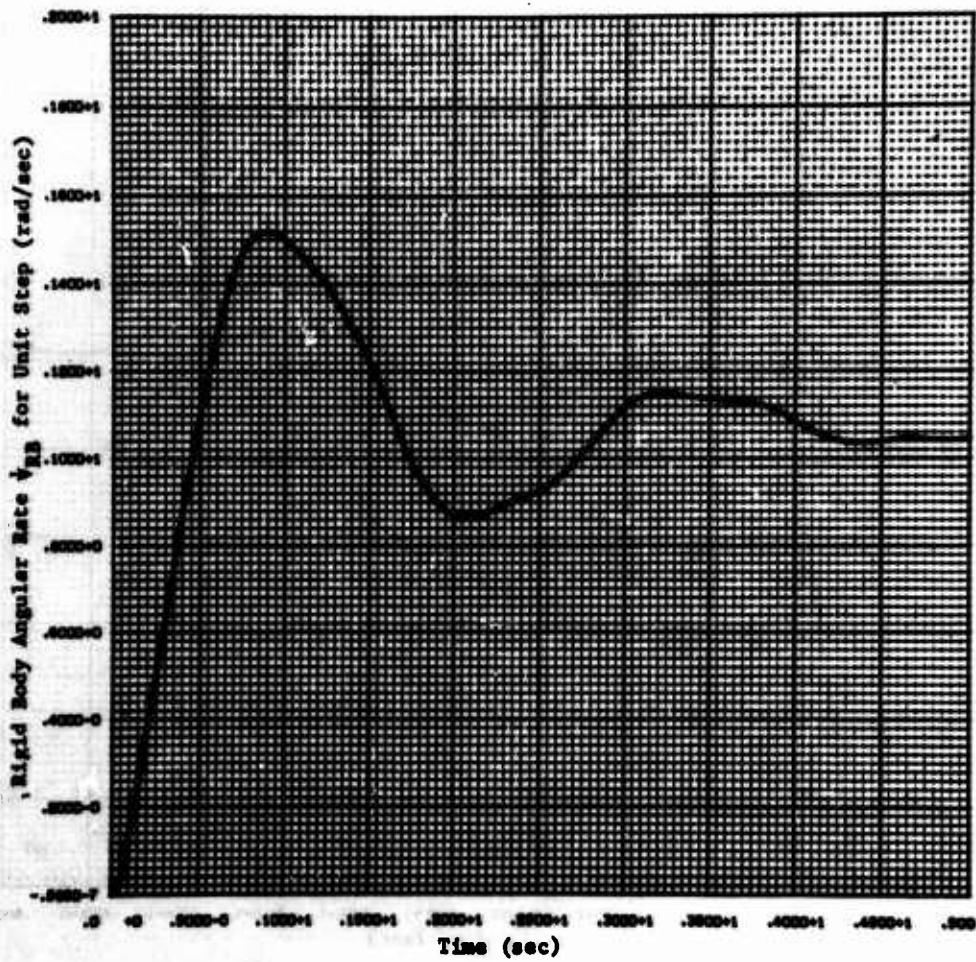

Fig. C-24 Transient Response, Yaw Axis (30 sec, AGC)

Flight Control System Configuration

Channel	Gain	Filter Configuration
Stage I Rate	$K_{RI} = 0.38$	$\frac{1}{(1 + s/15)^2}$
Stage II Rate	$K_{R2} = 0.25$	$\frac{1}{(1 + s/15)^2}$
Acceleration	$K_A = 0$	
Velocity	$K_V = 0$	
Displacement	$K_{RD} = 1.45$	$\frac{K_{RD}(7.5)}{(1 + 7.5s)(1 + s/5)}$

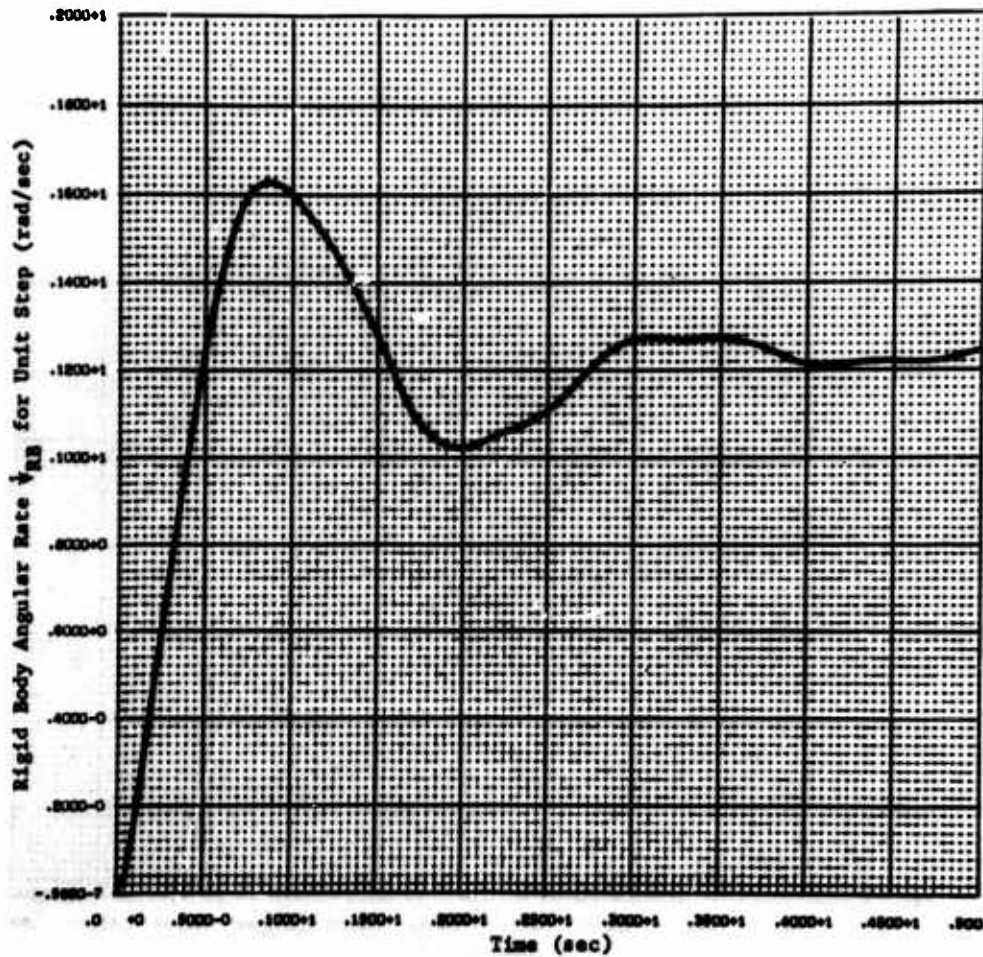

Fig. C-25 Transient Response, Yaw Axis (60 sec)

SSD-CR-64-32

Flight Control System Configuration

Channel	Gain	Filter Configuration
Stage I Rate	$K_{R1} = 0.38$	$\frac{1}{(1 + s/15)^2}$
Stage II Rate	$K_{R2} = 0.25$	$\frac{1}{(1 + s/15)^2}$
Acceleration	$K_A = 0$	
Velocity	$K_V = 0$	
Displacement	$K_{RD} = 1.45$	$\frac{K_{RD}(7.5)}{(1 + 7.5s)(1 + s/5)}$

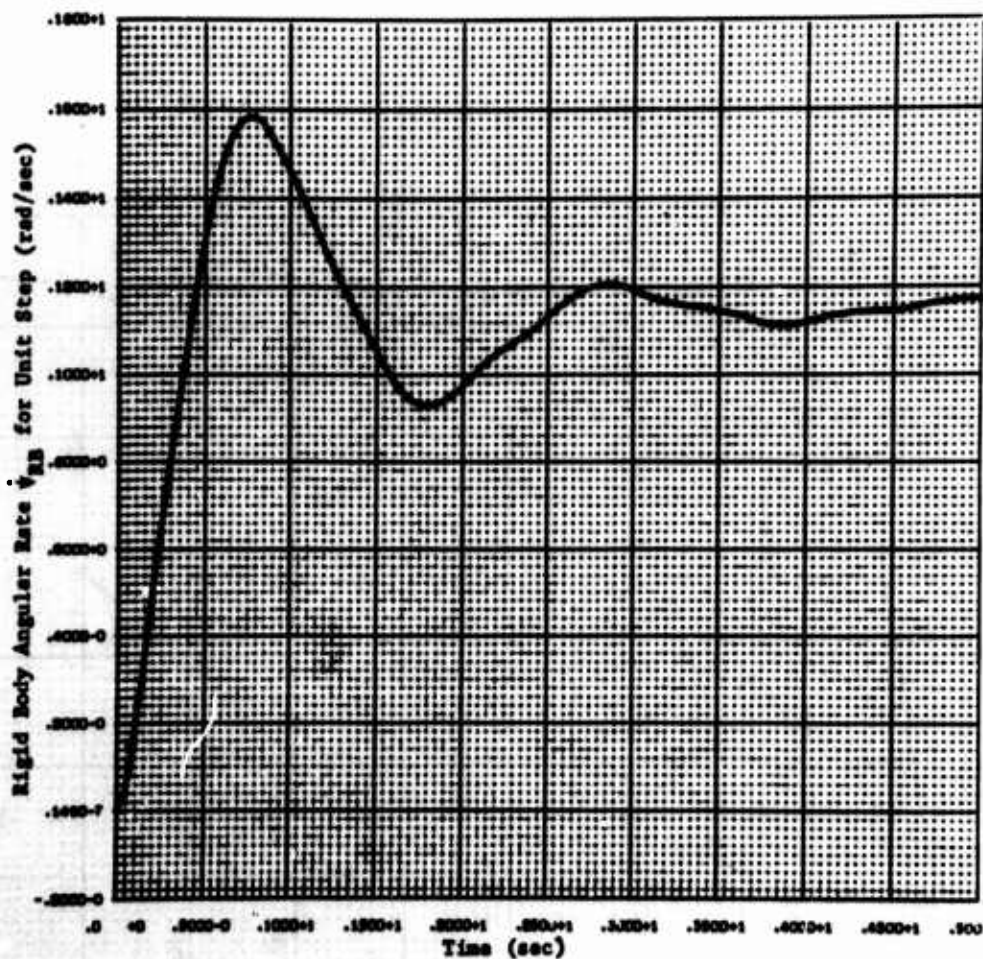

Fig. C-26 Transient Response, Yaw Axis (80 sec, BGC)

Flight Control System Configuration

Channel	Gain	Filter Configuration
Stage I Rate	$K_{R1} = 0.48$	$\frac{1}{(1 + S/15)^2}$
Stage II Rate	$K_{R2} = 0.32$	$\frac{1}{(1 + S/15)^2}$
Acceleration	$K_A = 0$	
Velocity	$K_V = 0$	
Displacement	$K_{RD} = 2.44$	$\frac{K_{RD} 7.5}{(1 + 7.5S)(1 + S/5)}$

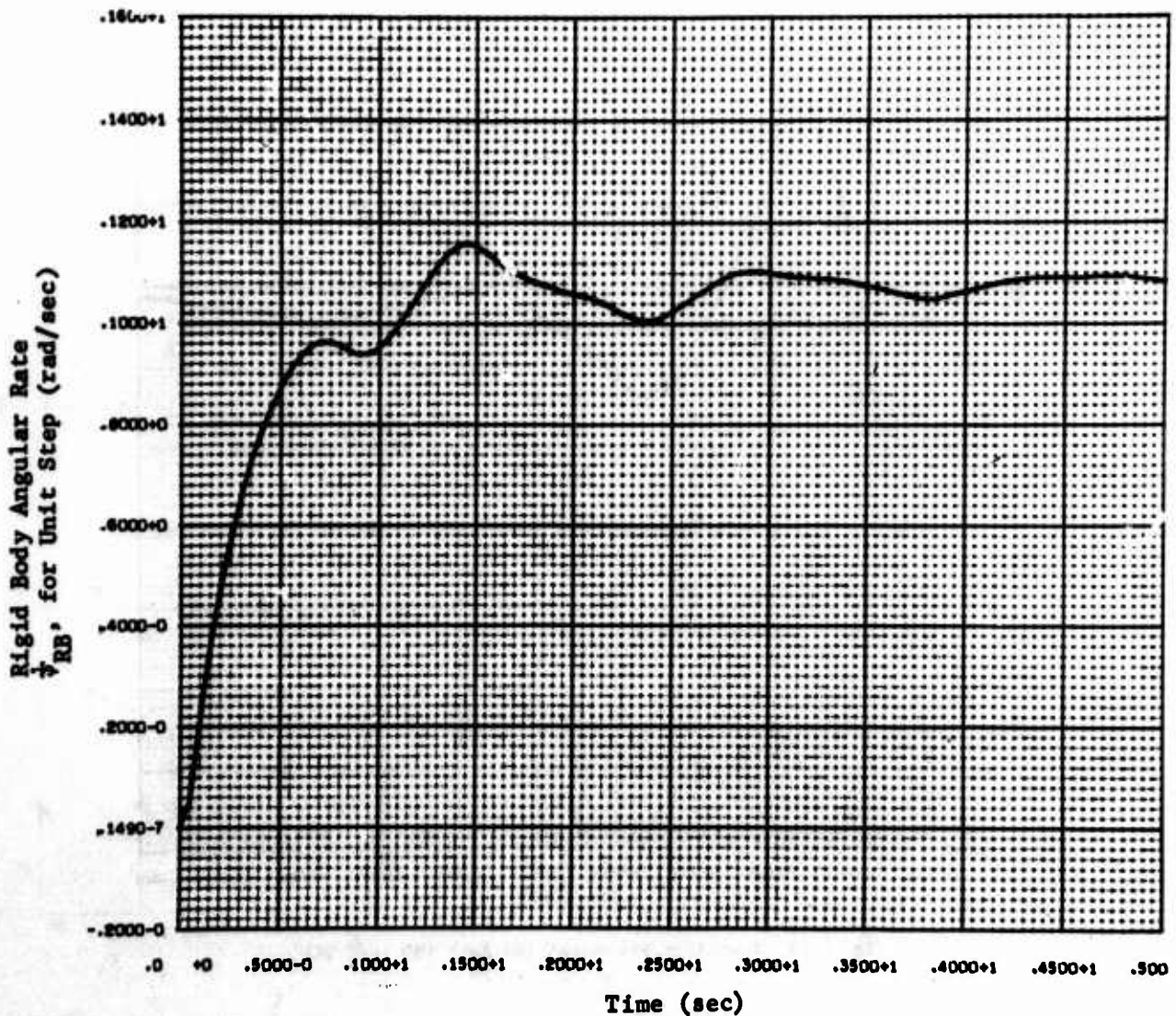

Fig. C-27 Transient Response, Yaw Axis (80 sec, AGC)

Flight Control System Configuration

Channel	Gain	Filter Configuration
Stage I Rate	$K_{R1} = 0.48$	$\frac{1}{(1 + S/15)^2}$
Stage II Rate	$K_{R2} = 0.32$	$\frac{1}{(1 + S/15)^2}$
Acceleration	$K_A = 0$	
Velocity	$K_V = 0$	
Displacement	$K_{RD} = 2.44$	$\frac{K_{RD} 7.5}{(1 + 7.5S)(1 + S/5)}$

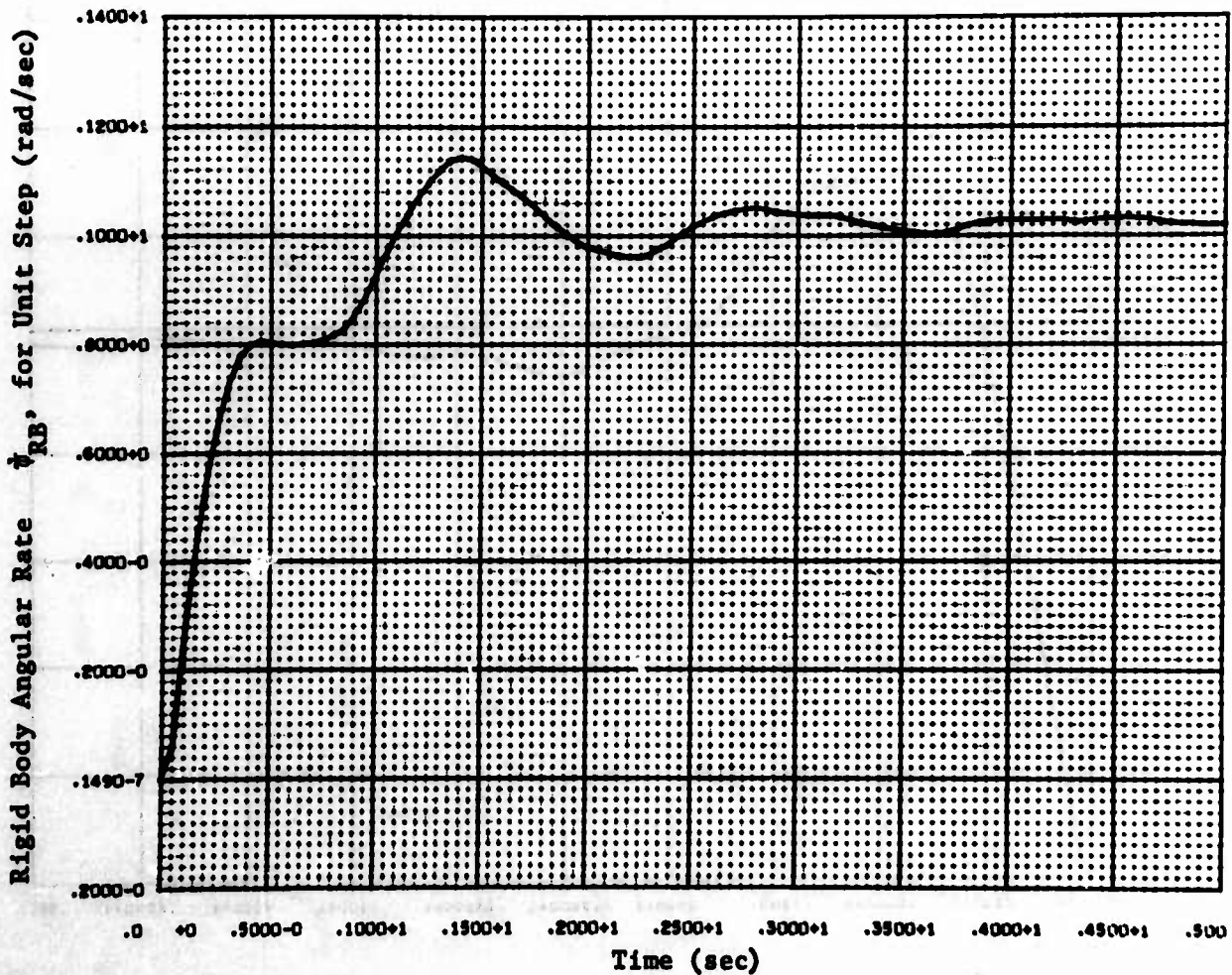

Fig. C-28 Transient Response, Yaw Axis (105 sec)

Flight Control System Configuration

Channel	Gain	Filter Configuration
Displacement	$K_D = 1.11$	$\frac{1}{(1 + s/15)}$
Stage I Rate	$K_{R1} = 0.46$	$\frac{1}{(1 + s/40)^2}$
Stage II Rate	$K_{R2} = 0.17$	$\frac{1}{(1 + s/30)^2}$
Acceleration	$K_A = 0$	
Velocity	$K_V = 0$	

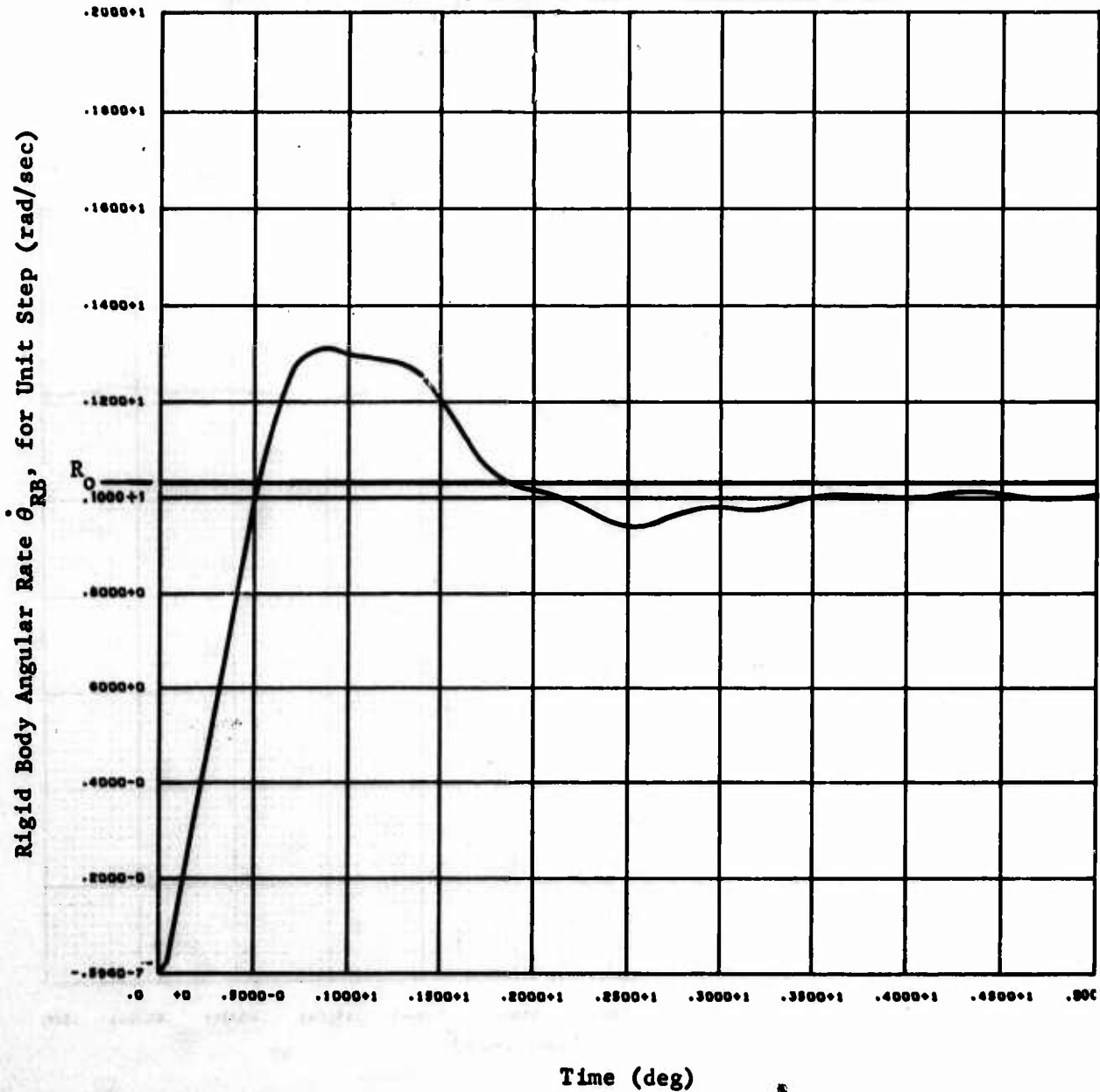

Fig. C-29 Transient Response, Pitch Axis, Without Load Relief (0 sec)

Flight Control System Configuration

Channel	Gain	Filter Configuration
Displacement	$K_D = 1.11$	$\frac{1}{(1 + s/15)}$
Stage I Rate	$K_{R1} = 0.46$	$\frac{1}{(1 + s/40)^2}$
Stage II Rate	$K_{R2} = 0.17$	$\frac{1}{(1 + s/30)^2}$
Acceleration	$K_A = 0$	
Velocity	$K_V = 0$	

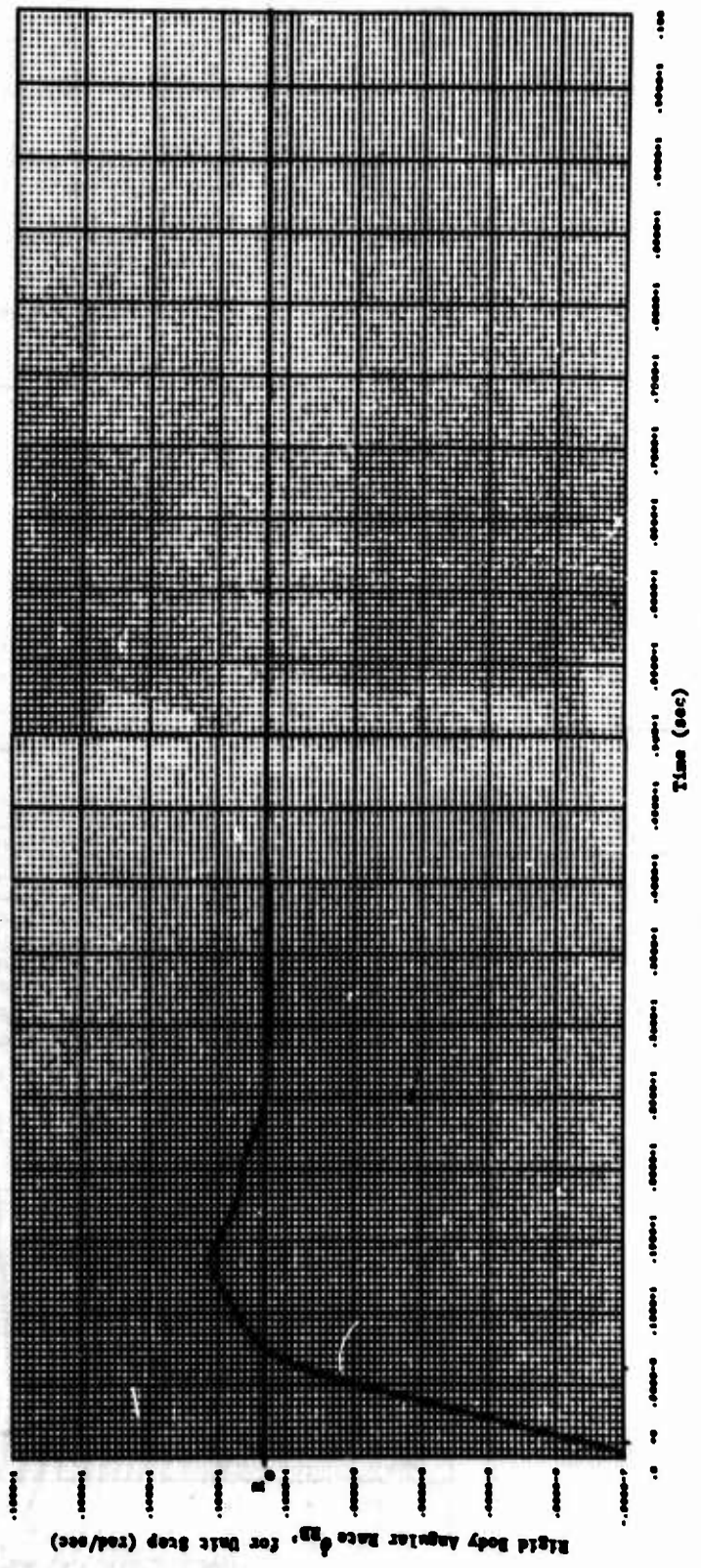

Fig. C-30 Transient Response, Pitch Axis, Without Load Relief (30 sec, AUC)

Flight Control System Configuration

Channel	Gain	Filter Configuration
Displacement	$K_D = 1.4$	$\frac{1}{(1 + s/15)}$
Stage I Rate	$K_{R1} = 0.52$	$\frac{1}{(1 + s/40)^2}$
Stage II Rate	$K_{R2} = 0.18$	$\frac{1}{(1 + s/30)^2}$
Acceleration	$K_A = 0$	
Velocity	$K_V = 0$	

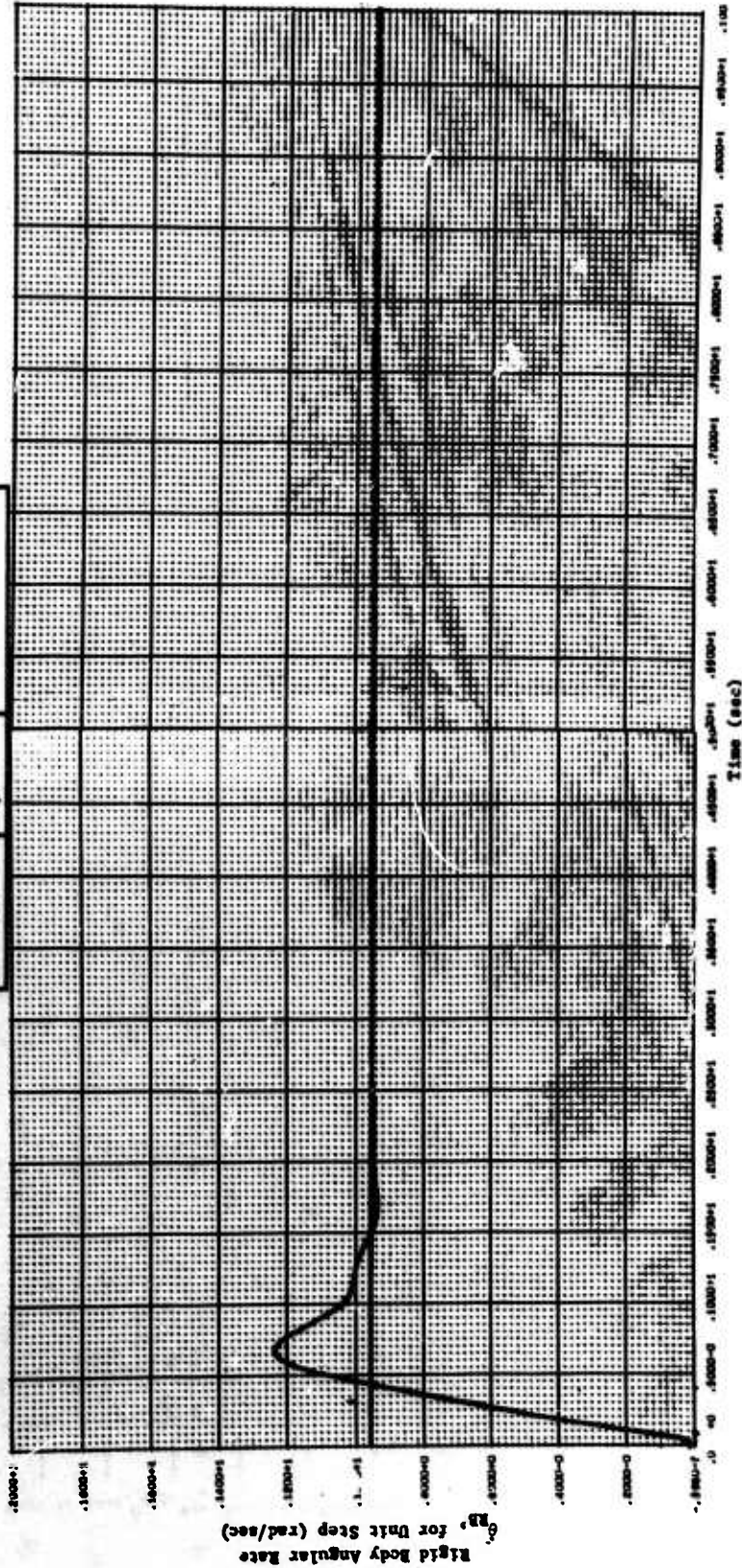

Fig. C-31 Transient Response, Pitch Axis, without Load Relief (80 sec, ROC)

Flight Control System Configuration

Channel	Gain	Filter Configuration
Displacement	$K_D = 1.0$	$\frac{1}{(1 + s/15)}$
Stage I Rate	$K_{I1} = 0.34$	$\frac{1}{(1 + s/40)^2}$
Stage II Rate	$K_{I2} = 0.195$	$\frac{1}{(1 + s/30)^2}$
Acceleration	$K_A = 0$	
Velocity	$K_V = 0$	

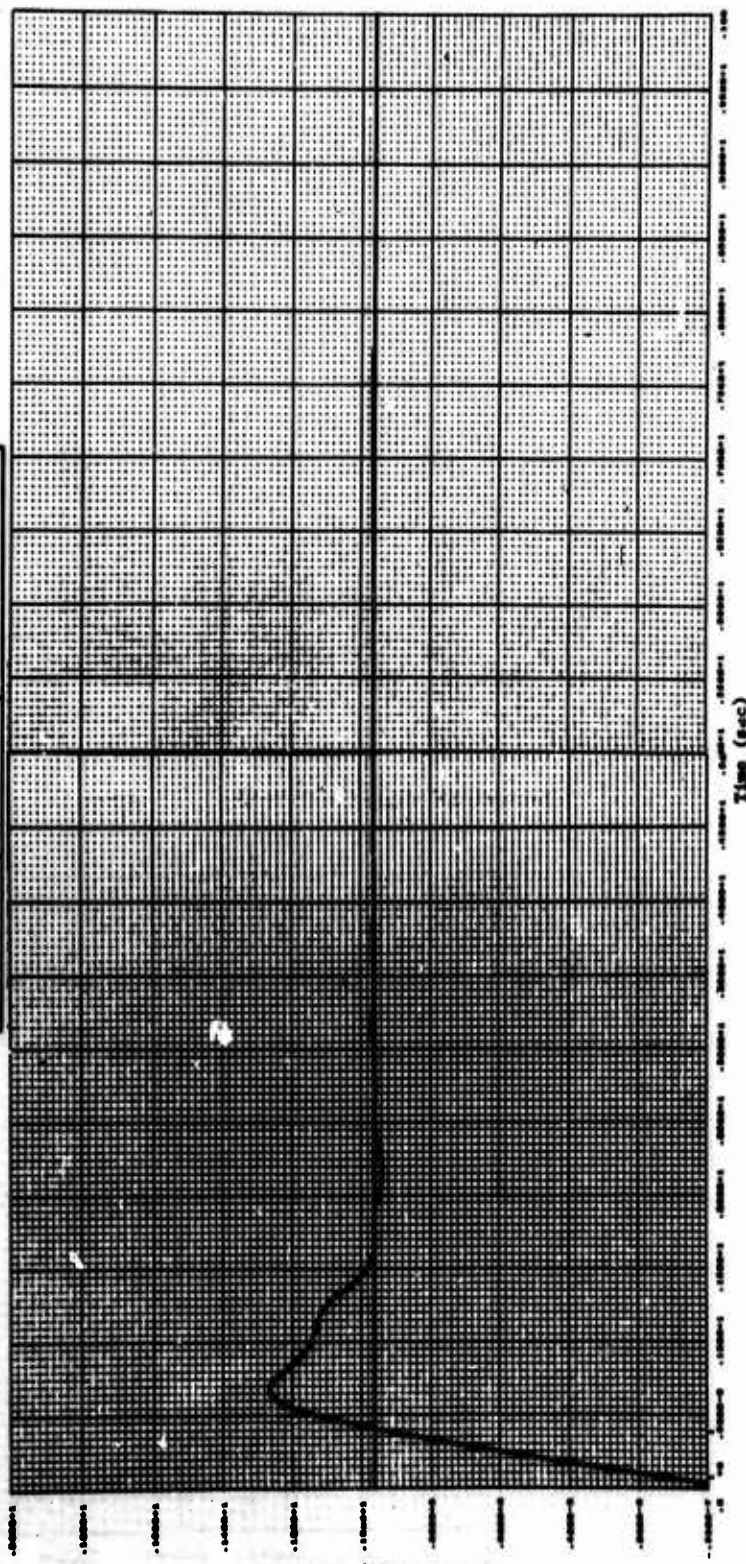

Fig. C-32 Transient Response, Pitch Axis, without Load Relief (105 sec)

SSD-CR-64-32
Flight Control System Configuration

Channel	Gain	Filter Configuration
Displacement	$K_D = 0.65$	$\frac{1}{(1 + s/15)^2}$
Stage I Rate	$K_{R1} = 0.38$	$\frac{1}{(1 + s/15)^2}$
Stage II Rate	$K_{R2} = 0.25$	$\frac{1}{(1 + s/15)^2}$
Acceleration	$K_A = 0$	
Velocity	$K_V = 0$	

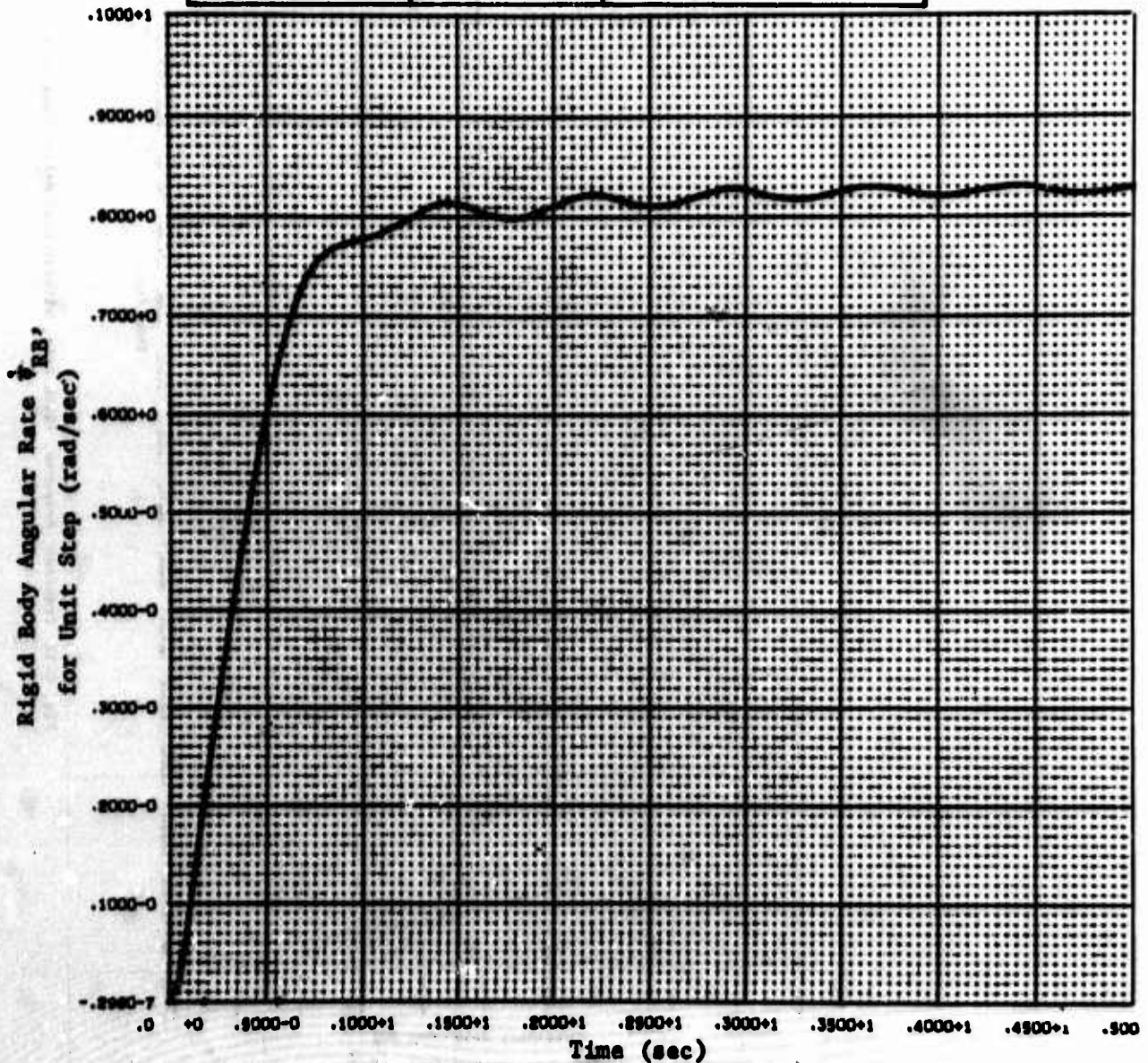

Fig. C-33 Transient Response, Yaw Axis, without Load Relief (60 sec)

SSD-CR-64-32
Flight Control System Configuration

C-35

Channel	Gain	Filter Configuration
Displacement	$K_D = 1.0$	$\frac{1}{(1 + S/15)^2}$
Stage I Rate	$K_{R1} = 0.48$	$\frac{1}{(1 + S/15)^2}$
Stage II Rate	$K_{R2} = 0.32$	$\frac{1}{(1 + S/15)^2}$
Acceleration	$K_A = 0$	
Velocity	$K_V = 0$	

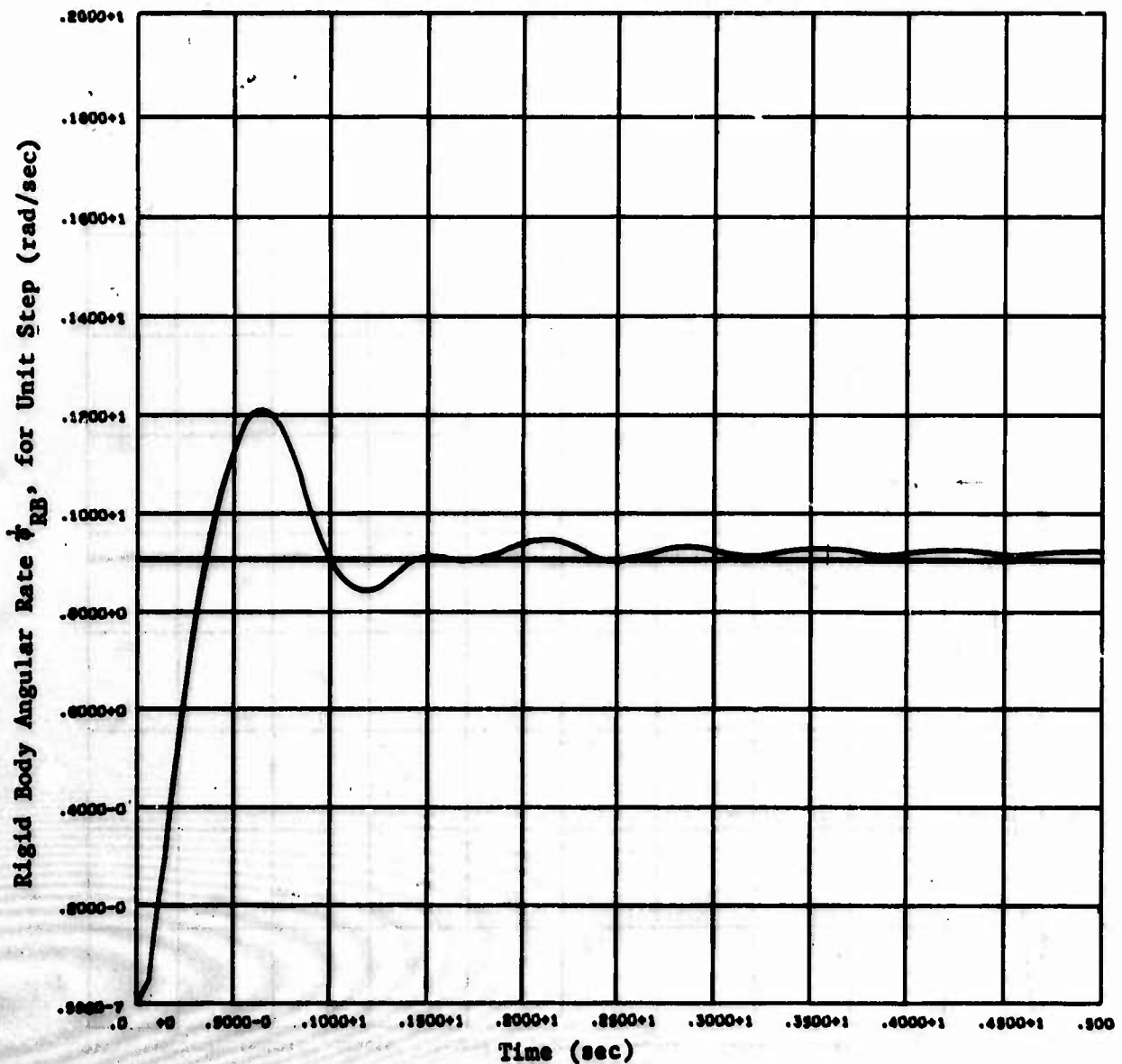

Fig. C-34 Transient Response, Yaw Axis, without Load Relief (80 sec, AGC)

Flight Control System Configuration

Channel	Gain	Filter Configuration
Displacement	$K_D = 1.0$	$\frac{1}{(1 + s/15)^2}$
Stage I Rate	$K_{R1} = 0.48$	$\frac{1}{(1 + s/15)^2}$
Stage II Rate	$K_{R2} = 0.32$	$\frac{1}{(1 + s/15)^2}$
Acceleration	$K_A = 0$	
Velocity	$K_V = 0$	

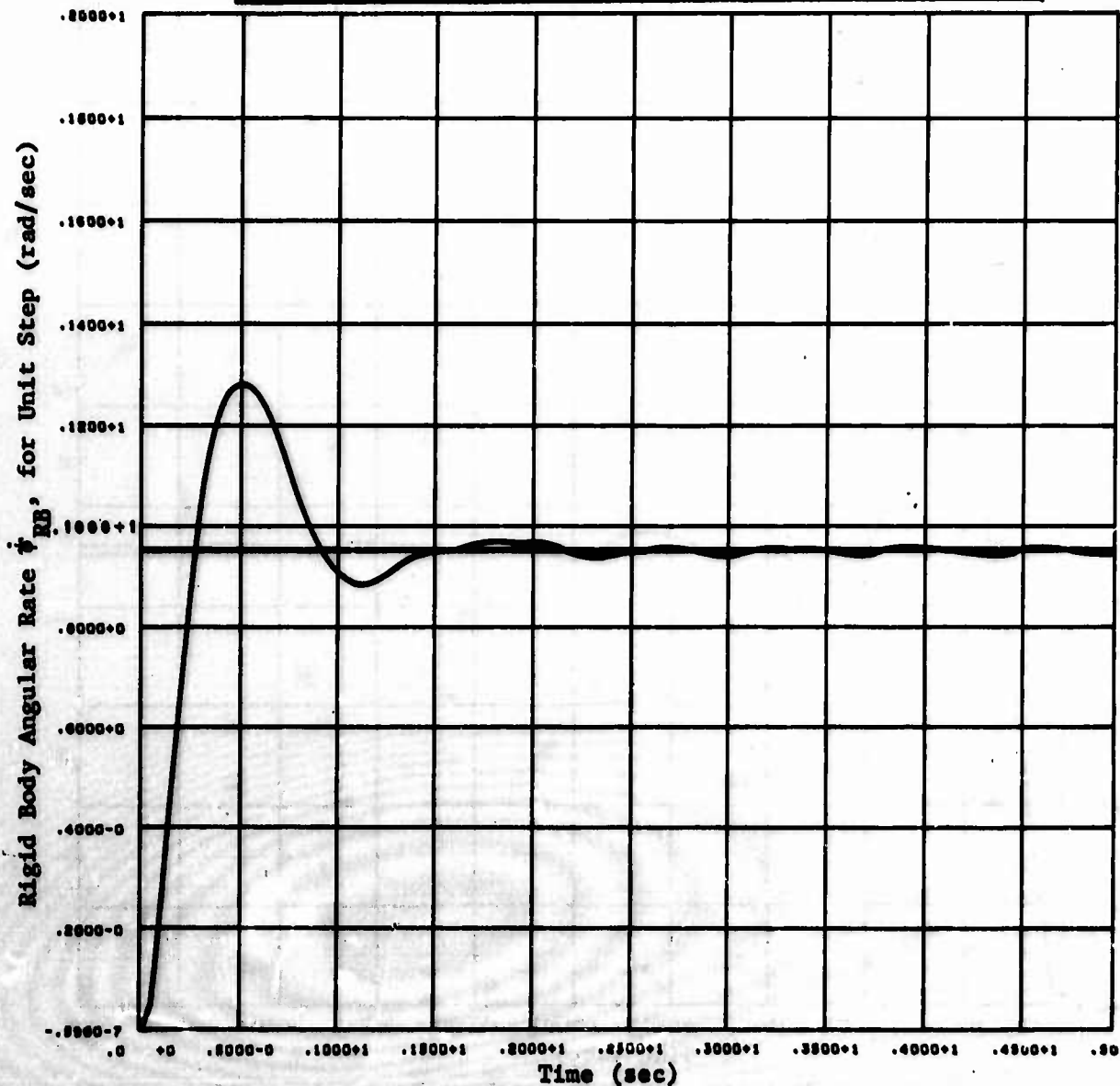

Fig. C-35 Transient Response, Yaw Axis, without Load Relief (105 sec)

Flight Control System Configuration

Channel	Gain	Filter Configuration
Displacement	$K_D = 1.4$	$\frac{1}{(1 + S/15)}$
Stage I Rate	$K_{R1} = 0.52$	$\frac{1}{(1 + S/40)^2}$
Stage II Rate	$K_{R2} = 0.18$	$\frac{1}{(1 + S/30)^2}$
Acceleration	$K_A = 0.00075$	$\frac{1 (1 + 1.875S)}{(1 + S/3)(1 + S/5)(1 + S/10)(1 + 7.5S)}$
Velocity	$K_V = 0.0003$	

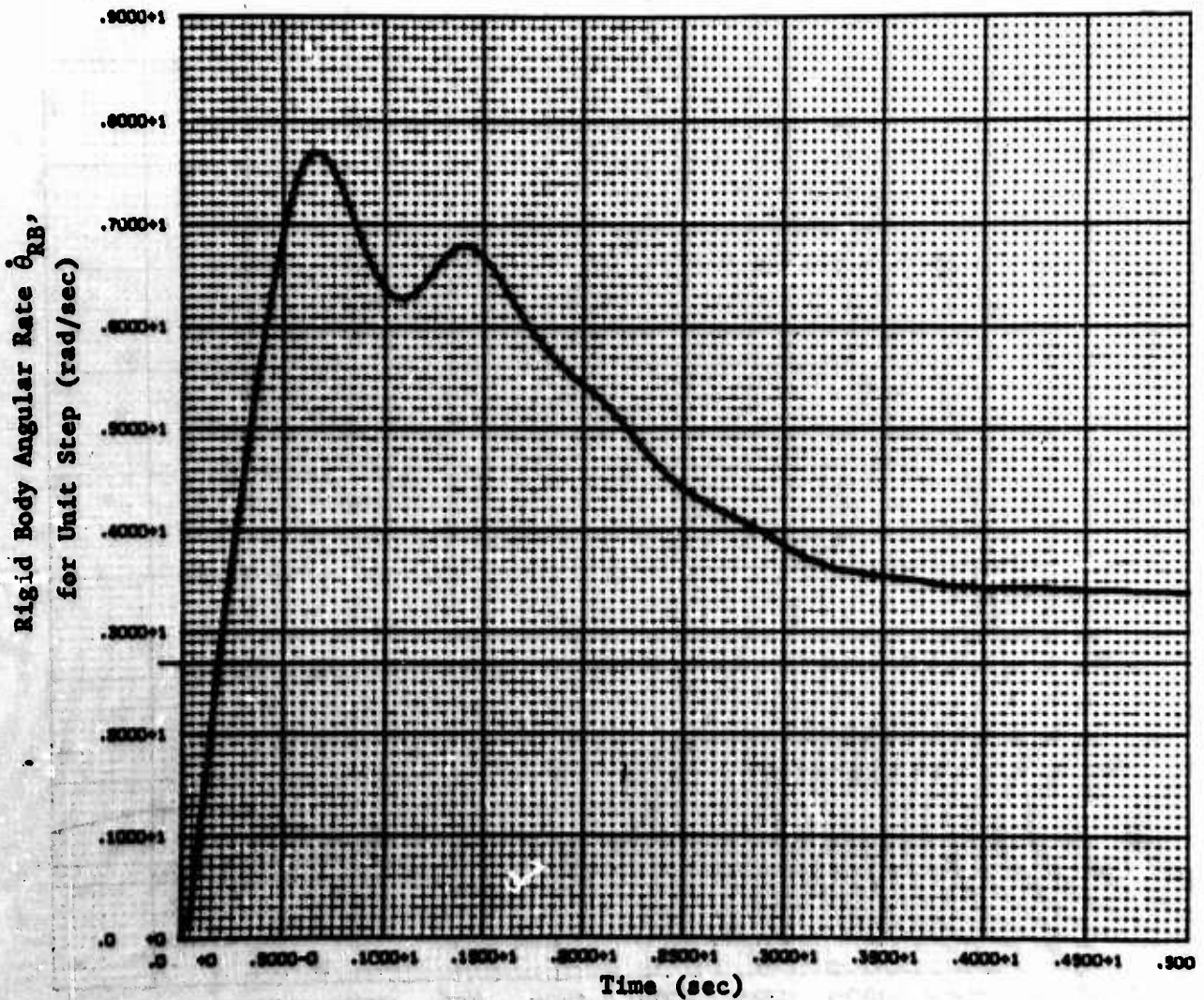

Fig. C-36 Transient Response, Pitch Axis, with Load Relief (30 sec., AGC)

Flight Control System Configuration

Channel	Gain	Filter Configuration
Displacement	$K_D = 1.4$	$\frac{1}{(1 + S/15)}$
Stage I Rate	$K_{R1} = 0.52$	$\frac{1}{(1 + S/40)^2}$
Stage II Rate	$K_{R2} = 0.18$	$\frac{1}{(1 + S/30)^2}$
Acceleration	$K_A = 0.00075$	$\frac{1 (1 + 1.875S)}{(1 + S/3)(1 + S/5)(1 + S/10)(1 + 7.5S)}$
Velocity	$K_V = 0.0003$	

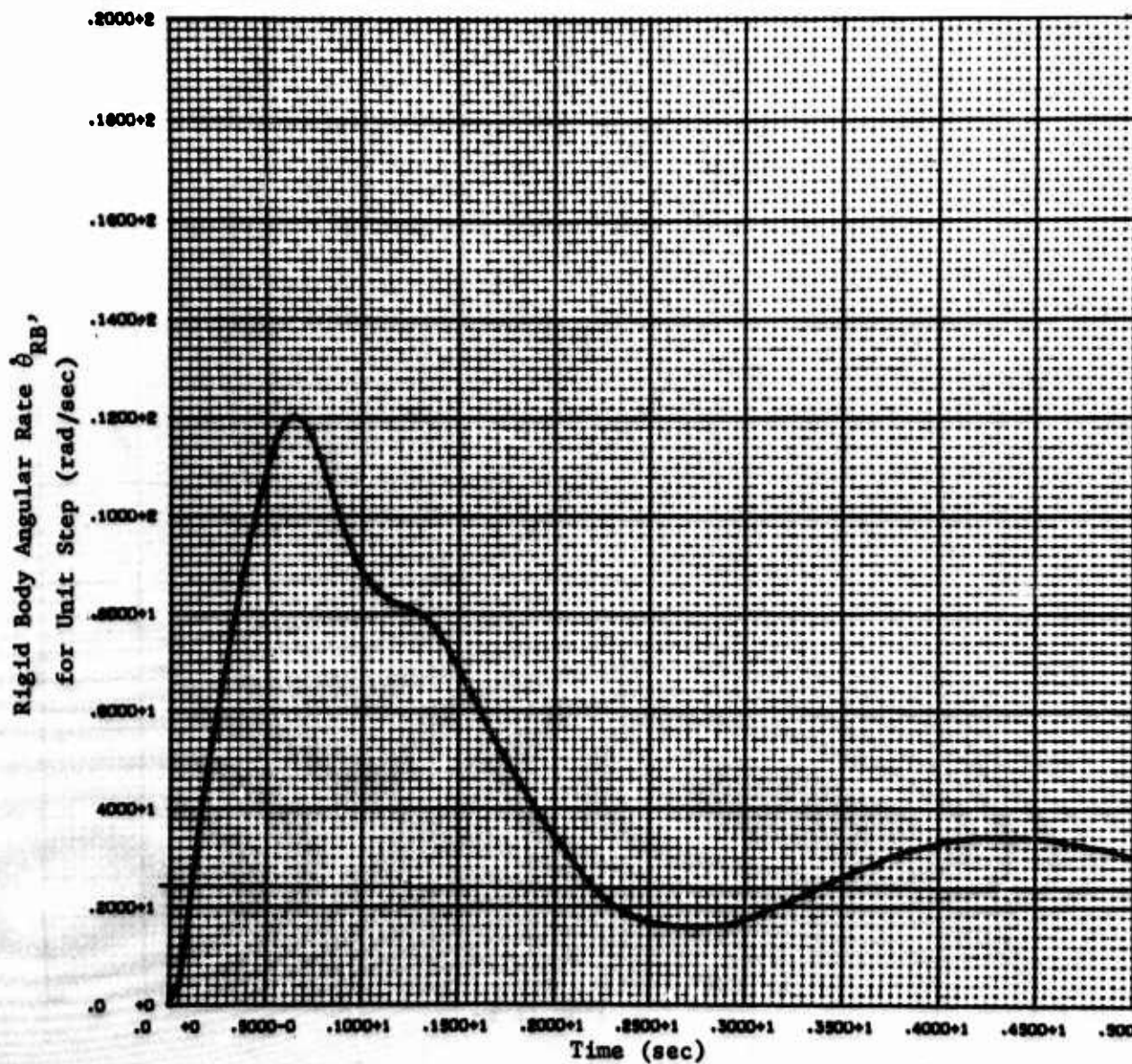

Fig. C-37 Transient Response, Pitch Axis, with Load Relief (60 sec)

Channel	Gain	Filter Configuration
Displacement	$K_D = 1.4$	$\frac{1}{(1 + S/15)}$
Stage I Rate	$K_{R1} = 0.52$	$\frac{1}{(1 + S/40)^2}$
Stage II Rate	$K_{R2} = 0.18$	$\frac{1}{(1 + S/30)^2}$
Acceleration	$K_A = 0.00075$	$\frac{1 (1 + 1.875S)}{(1 + S/3)(1 + S/5)(1 + S/10)(1 + 7.5S)}$
Velocity	$K_V = 0.0003$	

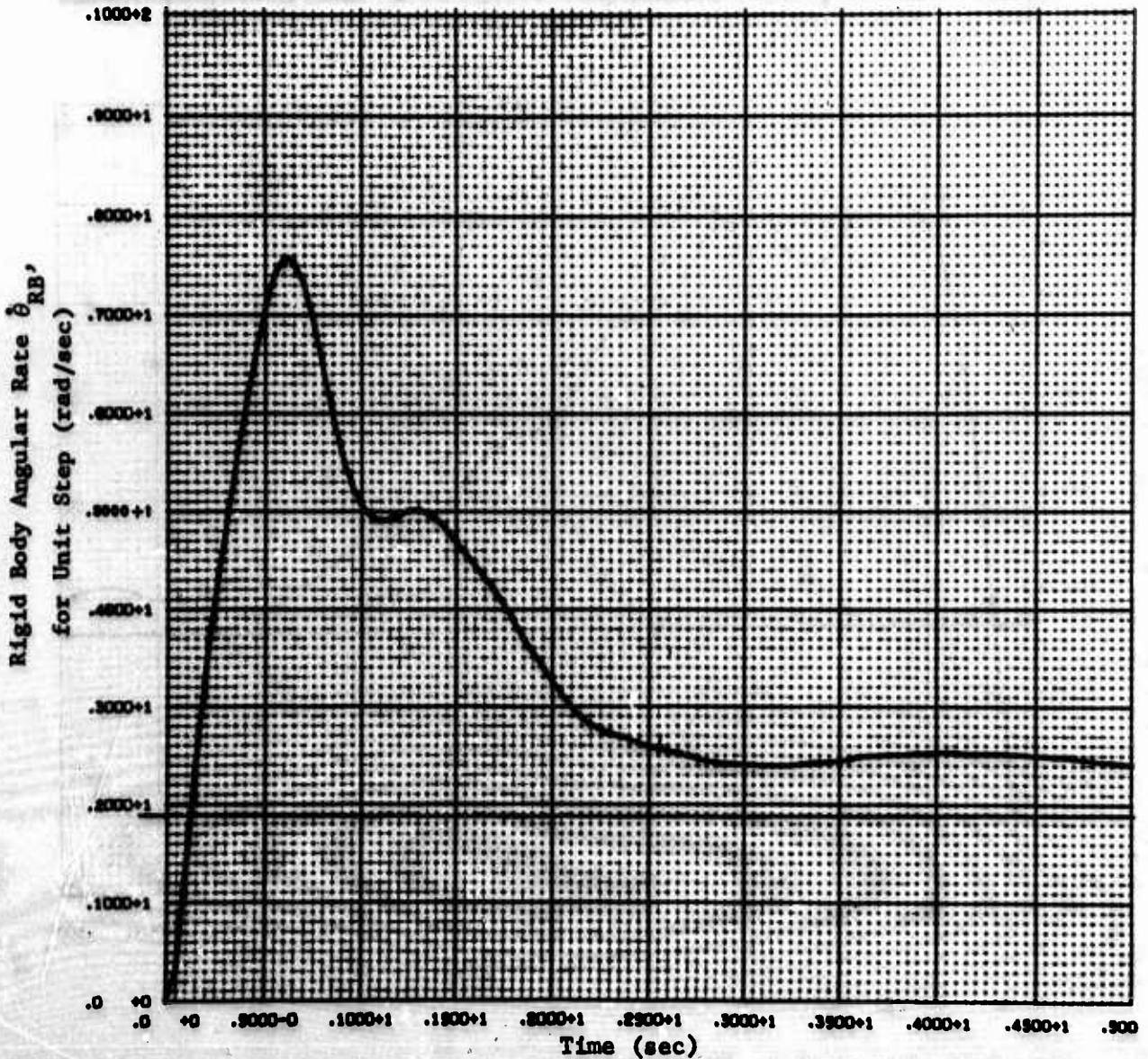

Fig. C-38 Transient Response, Pitch Axis, with Load Relief (80 sec, BGC)

Flight Control System Configuration

Channel	Gain	Filter Configuration
Displacement	$K_D = 0.65$	$\frac{1}{(1 + S/15)^2}$
Stage I Rate	$K_{R1} = 0.38$	$\frac{1}{(1 + S/15)^2}$
Stage II Rate	$K_{R2} = 0.25$	$\frac{1}{(1 + S/15)^2}$
Acceleration	$K_A = 0.001$	$\frac{1}{(1 + 2.42 S)}$
Velocity	$K_V = 0.00028$	$(1 + S/10)^2(1 + S/3)(1 + 7.5S)$

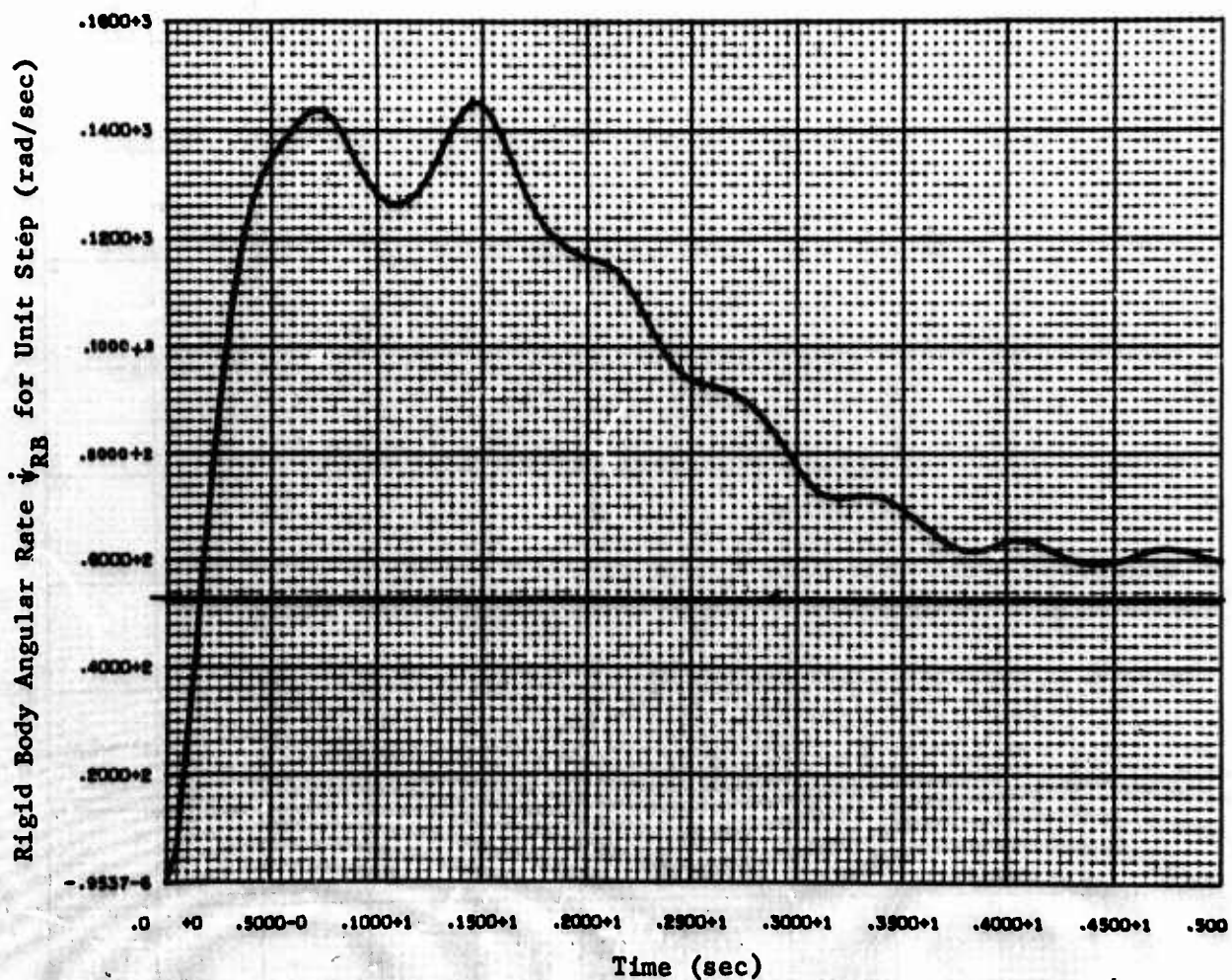

Fig. C-39 Transient Response, Yaw Axis, with Load Relief (60 sec)

Flight Control System Configuration

Channel	Gain	Filter Configuration
Displacement	$K_D = 0$	
Stage I Rate	$K_{R1} = 0.37$	$\frac{1}{(1 + s/40)^2}$
Stage II Rate	$K_{R2} = 0.41$	$\frac{1}{(1 + s/30)^2}$
Acceleration	$K_A = 0$	
Velocity	$K_V = 0$	

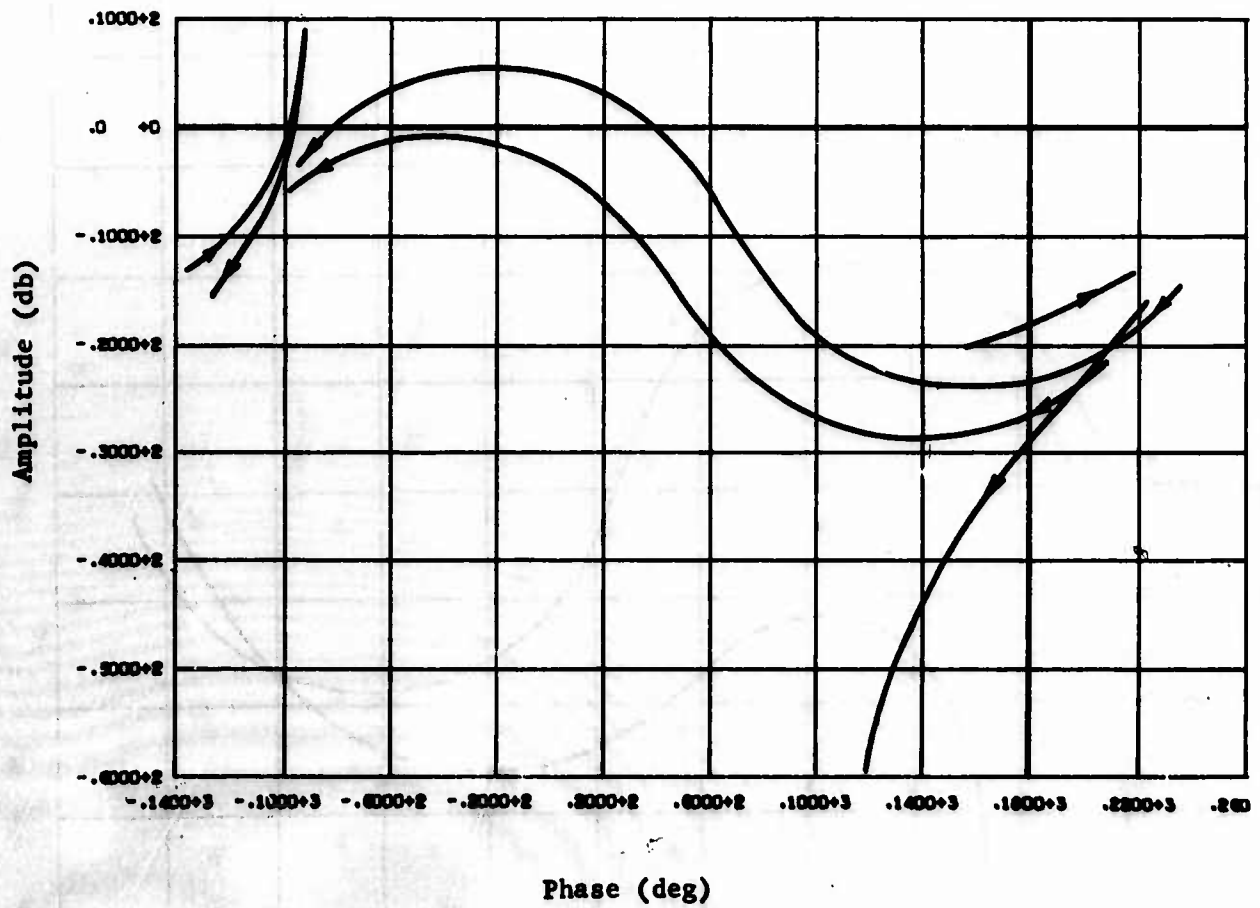

Fig. C-40 Open Loop Frequency Response, Pitch and Yaw Axis, Stage I Start

Flight Control System Configuration

Channel	Gain	Filter Configuration
Displacement	$K_D = 0$	
Stage I Rate	$K_{R1} = 0.37$	$\frac{1}{(1 + s/40)^2}$
Stage II Rate	$K_{R2} = 0.41$	$\frac{1}{(1 + s/30)^2}$
Acceleration	$K_A = 0$	
Velocity	$K_V = 0$	

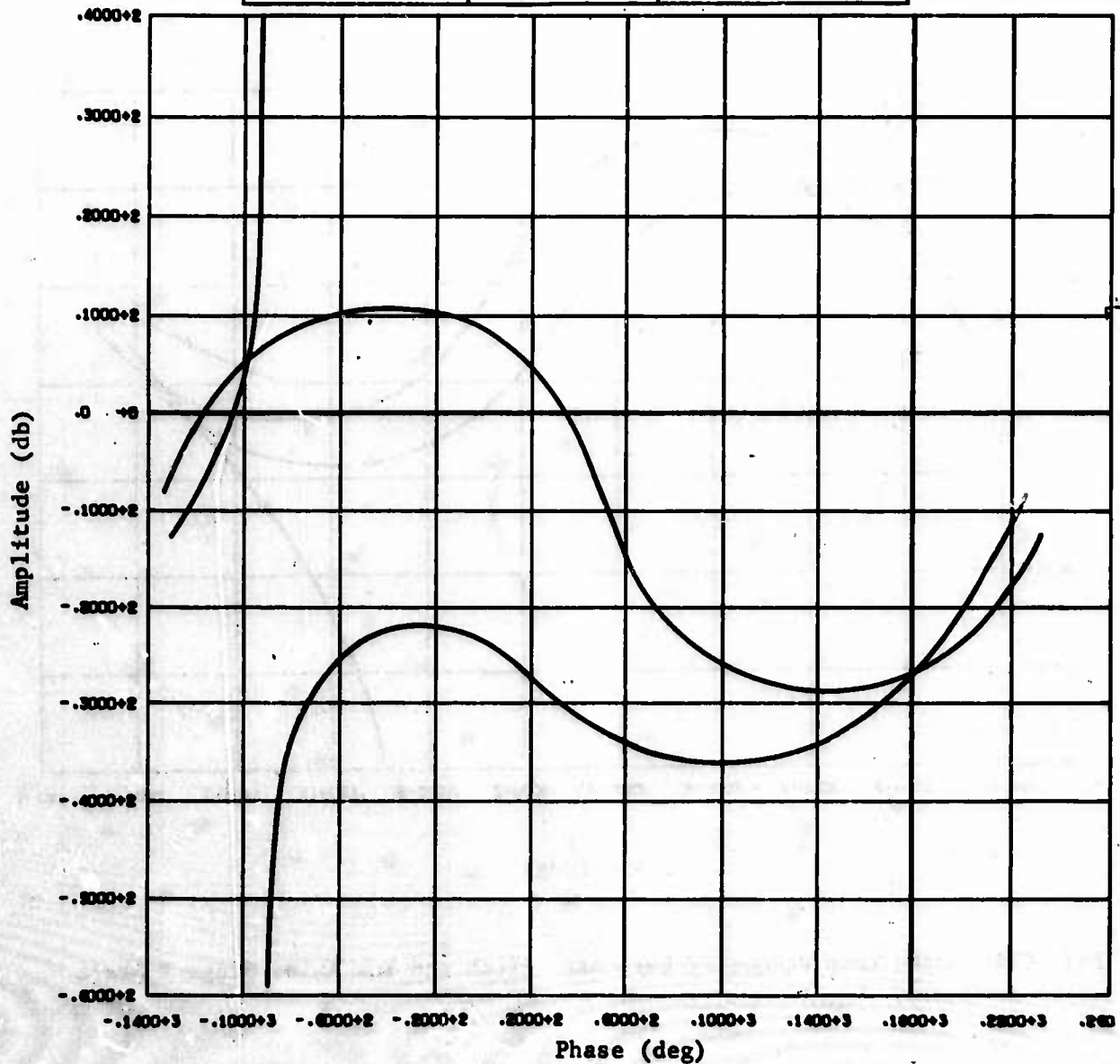

Fig. C-41 Open Loop Frequency Response Pitch and Yaw Axis, Stage I Midflight (BGC)

Flight Control System Configuration

Channel	Gain	Filter Configuration
Displacement	$K_D = 0$	
Stage I Rate	$K_{R1} = 0.20$	$\frac{1}{(1 + s/40)^2}$
Stage II Rate	$K_{R2} = 0.38$	$\frac{1}{(1 + s/30)^2}$
Acceleration	$K_A = 0$	
Velocity	$K_V = 0$	

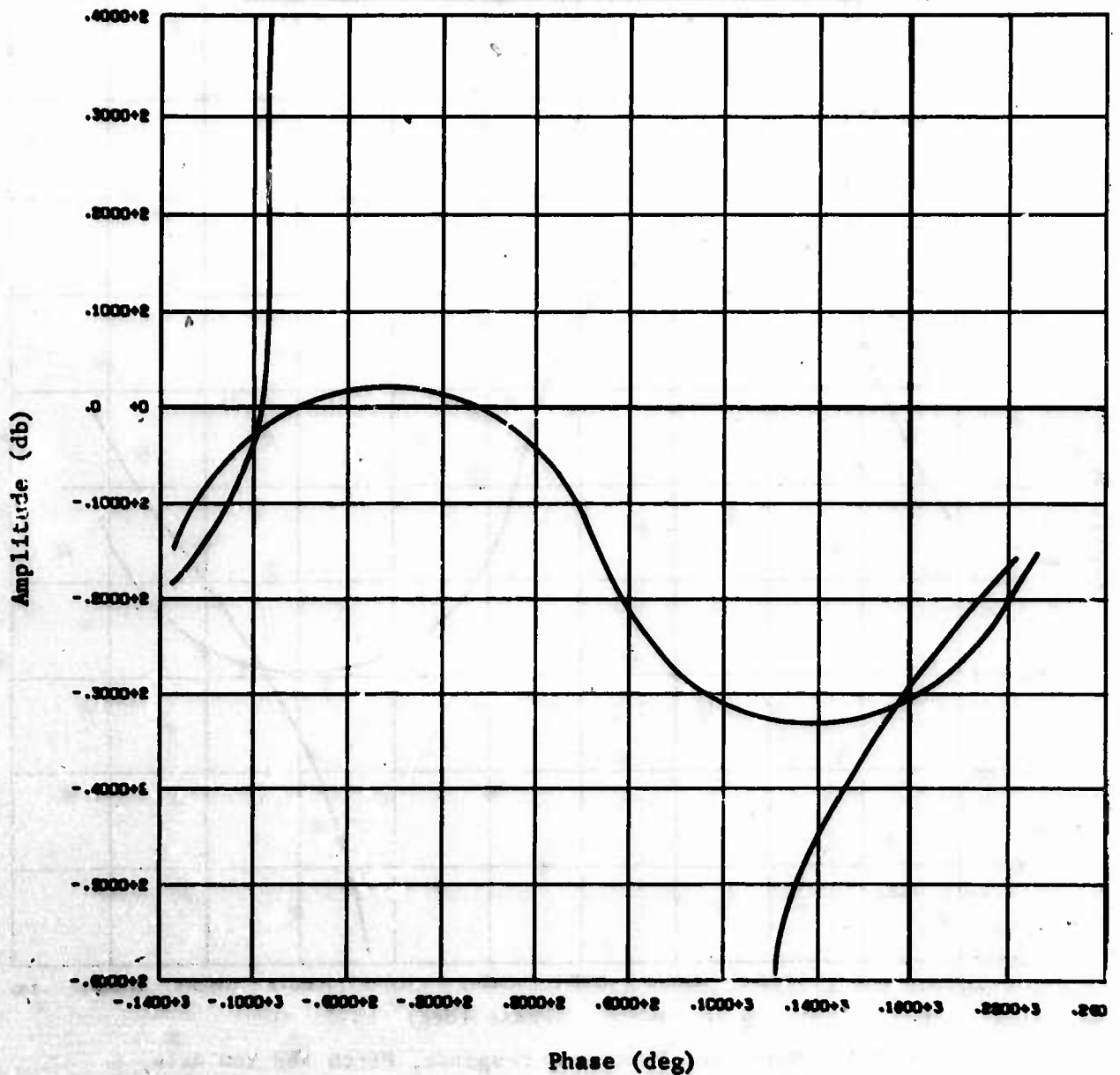

Fig. C-42 Open Loop Frequency Response, Pitch and Yaw Axis, Stage I Midflight (AGC)

Flight Control System Configuration

Channel	Gain	Filter Configuration
Displacement	$K_D = 0$	
Stage I Rate	$K_{R1} = 0.20$	$\frac{1}{(1 + s/40)^2}$
Stage II Rate	$K_{R2} = 0.38$	$\frac{1}{(1 + s/30)^2}$
Acceleration	$K_A = 0$	
Velocity	$K_V = 0$	

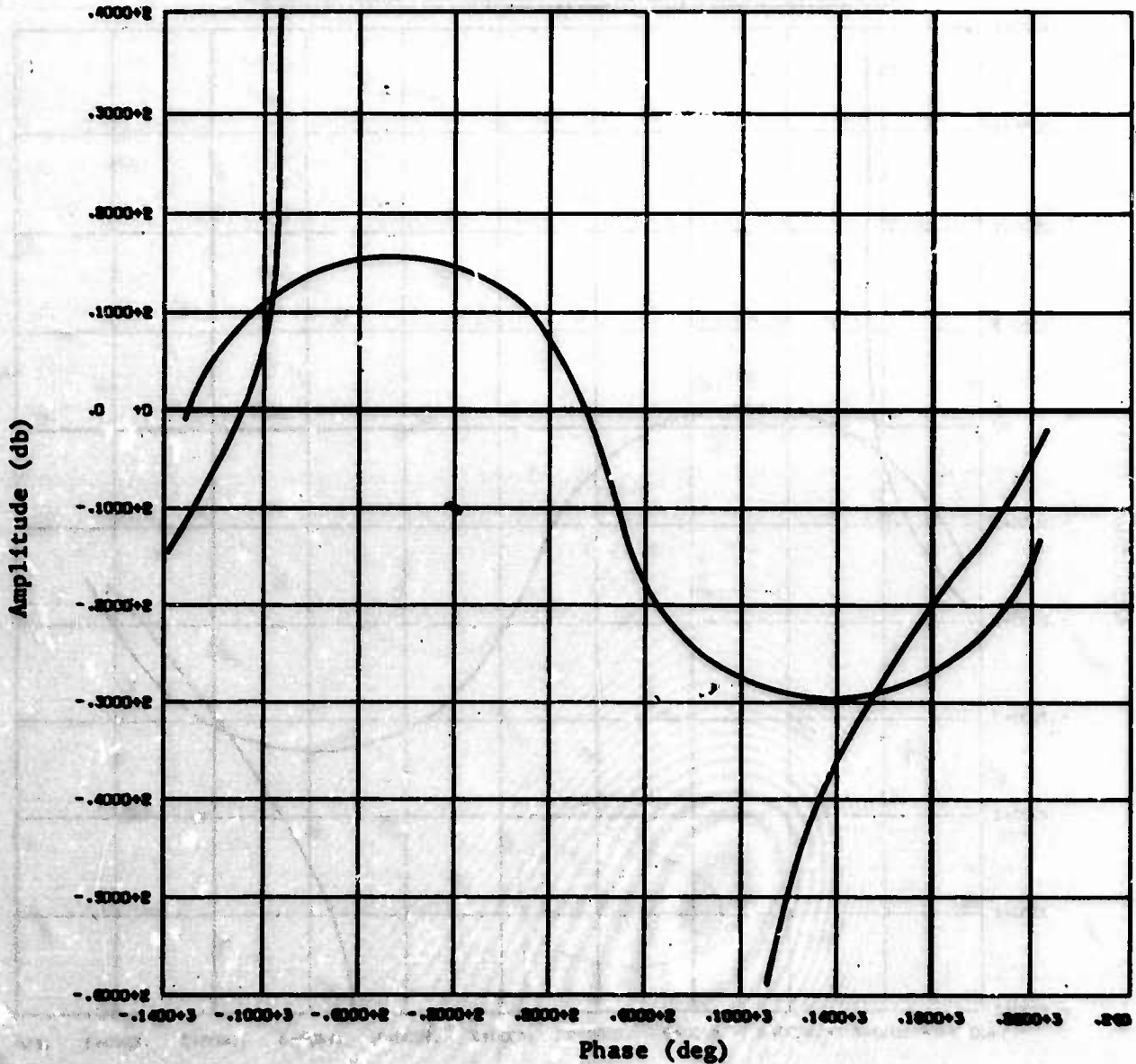

Fig. C-43 Open Loop Frequency Response, Pitch and Yaw Axis, Stage I Burnout

Flight Control System Configuration

Channel	Gain	Filter Configuration
Displacement	$K_D = 0$	
Stage I Rate	$K_{R1} = 0.16$	$\frac{1}{(1 + s/20)}$
Stage II Rate	$K_{R2} = 0$	
Acceleration	$K_A = 0$	
Velocity	$K_V = 0$	

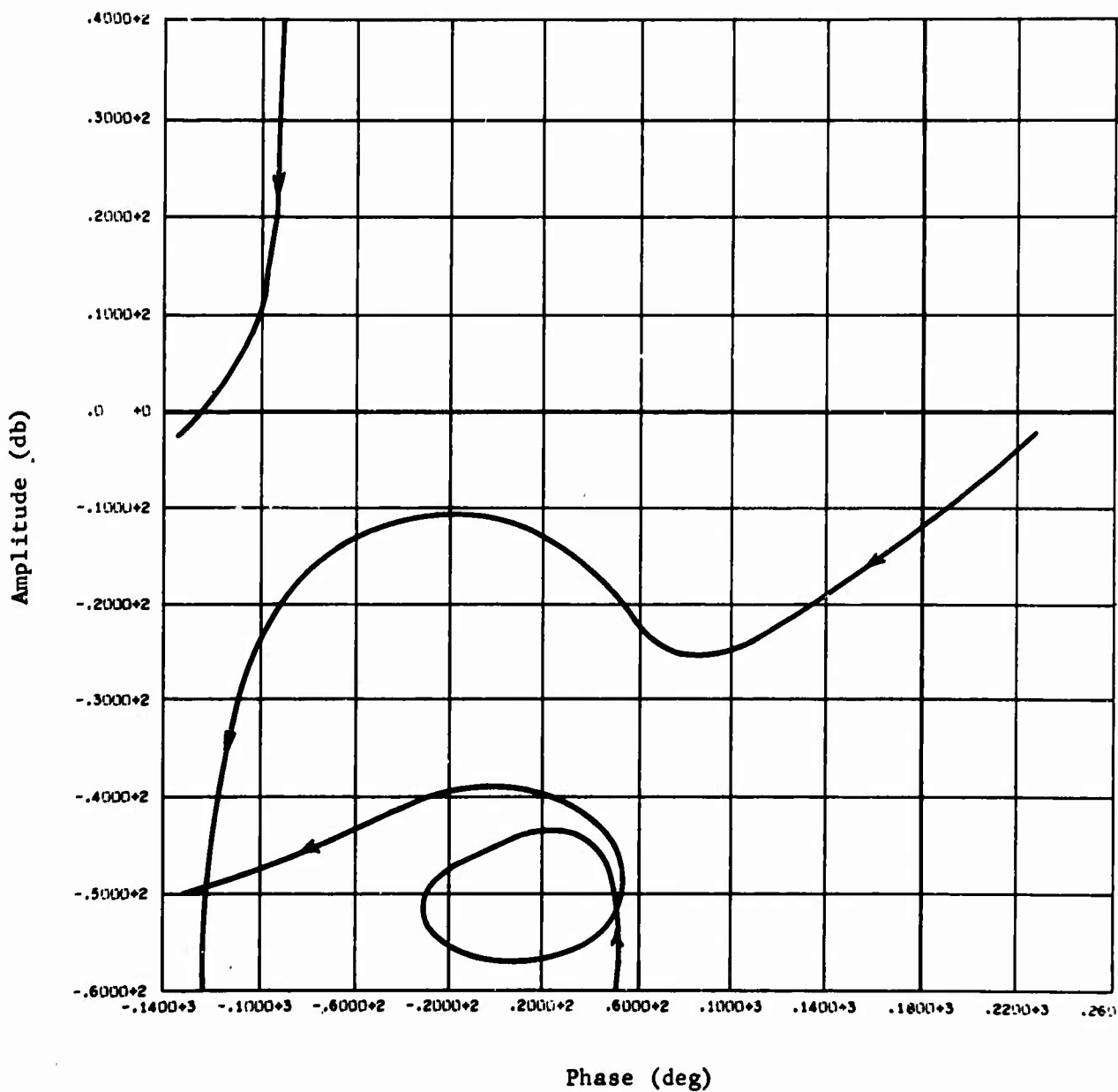

Fig. C-44 Open Loop Frequency Response, Roll Axis, Stage I

Flight Control System Configuration

Channel	Gain	Filter Configuration
Displacement	$K_D = 0$	$\frac{1}{(1 + s/40)^2}$
Stage I Rate	$K_{R1} = 0$	
Stage II Rate	$K_{R2} = 0.275$	
Acceleration	$K_A = 0$	
Velocity	$K_V = 0$	

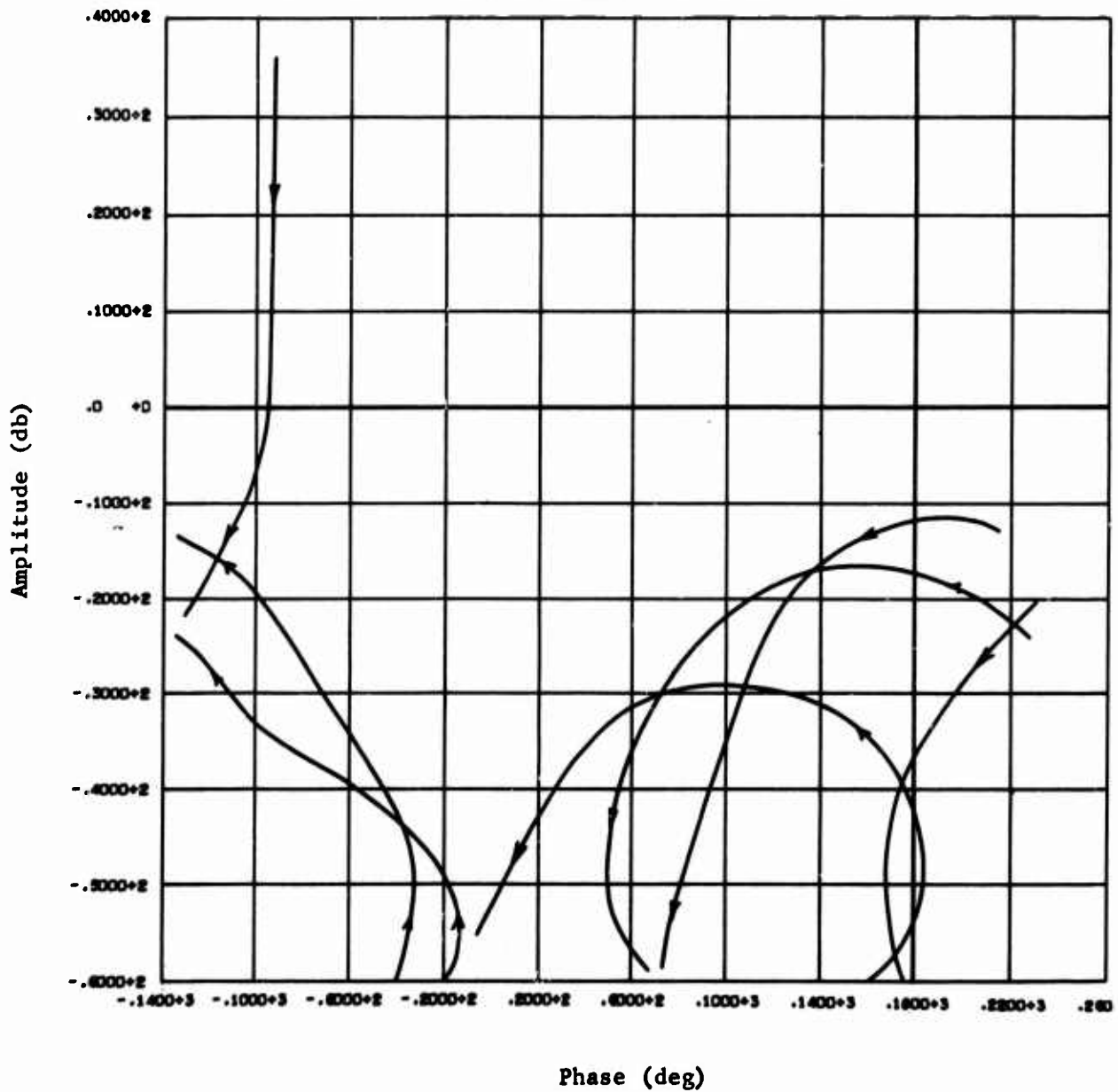

Fig. C-45 Open Loop Frequency Response, Pitch and Yaw Axis, Stage II Start

Flight Control System Configuration

Channel	Gain	Filter Configuration
Displacement	$K_D = 0$	$\frac{1}{(1 + S/40)^2}$
Stage I Rate	$K_{R1} = 0$	
Stage II Rate	$K_{R2} = 0.275$	
Acceleration	$K_A = 0$	
Velocity	$K_V = 0$	

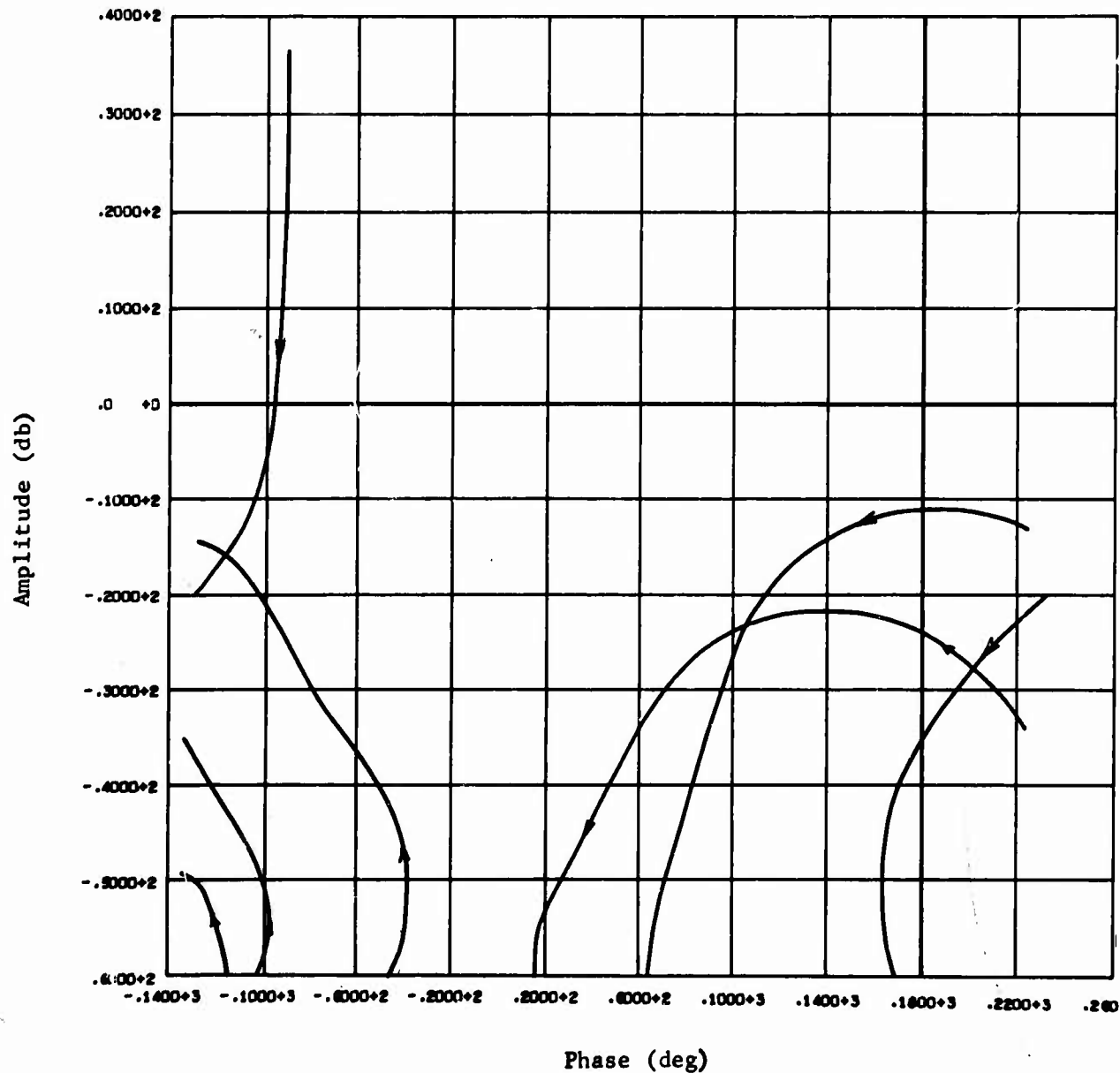

Fig. C-46 Open Loop Frequency Response, Pitch and Yaw Axis, Stage II Midflight (AGC)

Flight Control System Configuration

Channel	Gain	Filter Configuration
Displacement	$K_D = 0$	$\frac{1}{(1 + S/40)^2}$
Stage I Rate	$K_{R1} = 0$	
Stage II Rate	$K_{R2} = 0.275$	
Acceleration	$K_A = 0$	
Velocity	$K_A = 0$	

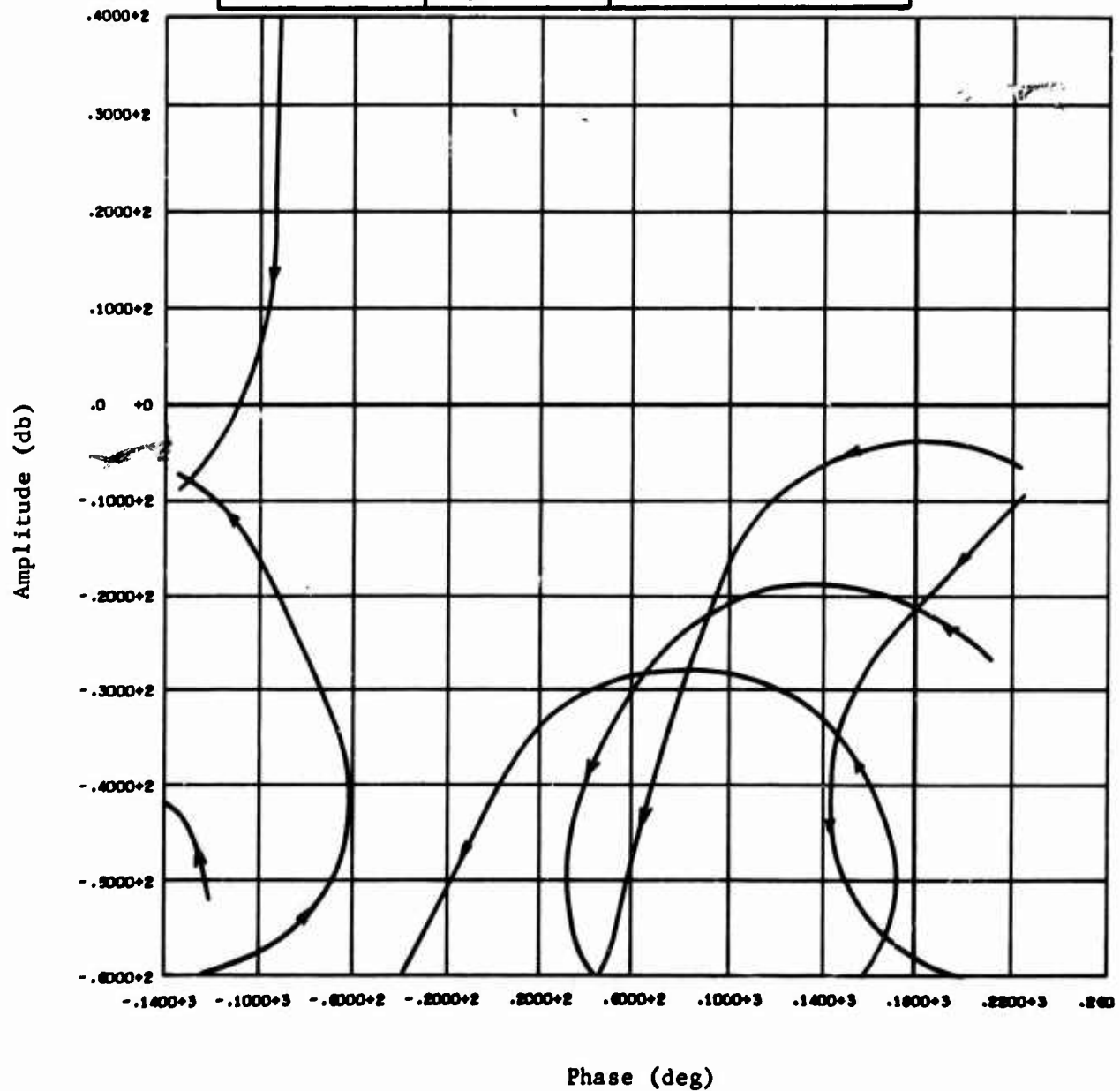

Fig. C-47 Open Loop Frequency Response, Pitch and Yaw Axes, Stage II Burnout

Flight Control System Configuration

Channel	Gain	Filter Configuration
Displacement	$K_D = 0$	$\frac{1}{(1 + S/20)}$
Stage I Rate	$K_{R1} = 0$	
Stage II Rate	$K_{R2} = 15.0$	
Acceleration	$K_A =$	
Velocity	$K_V =$	

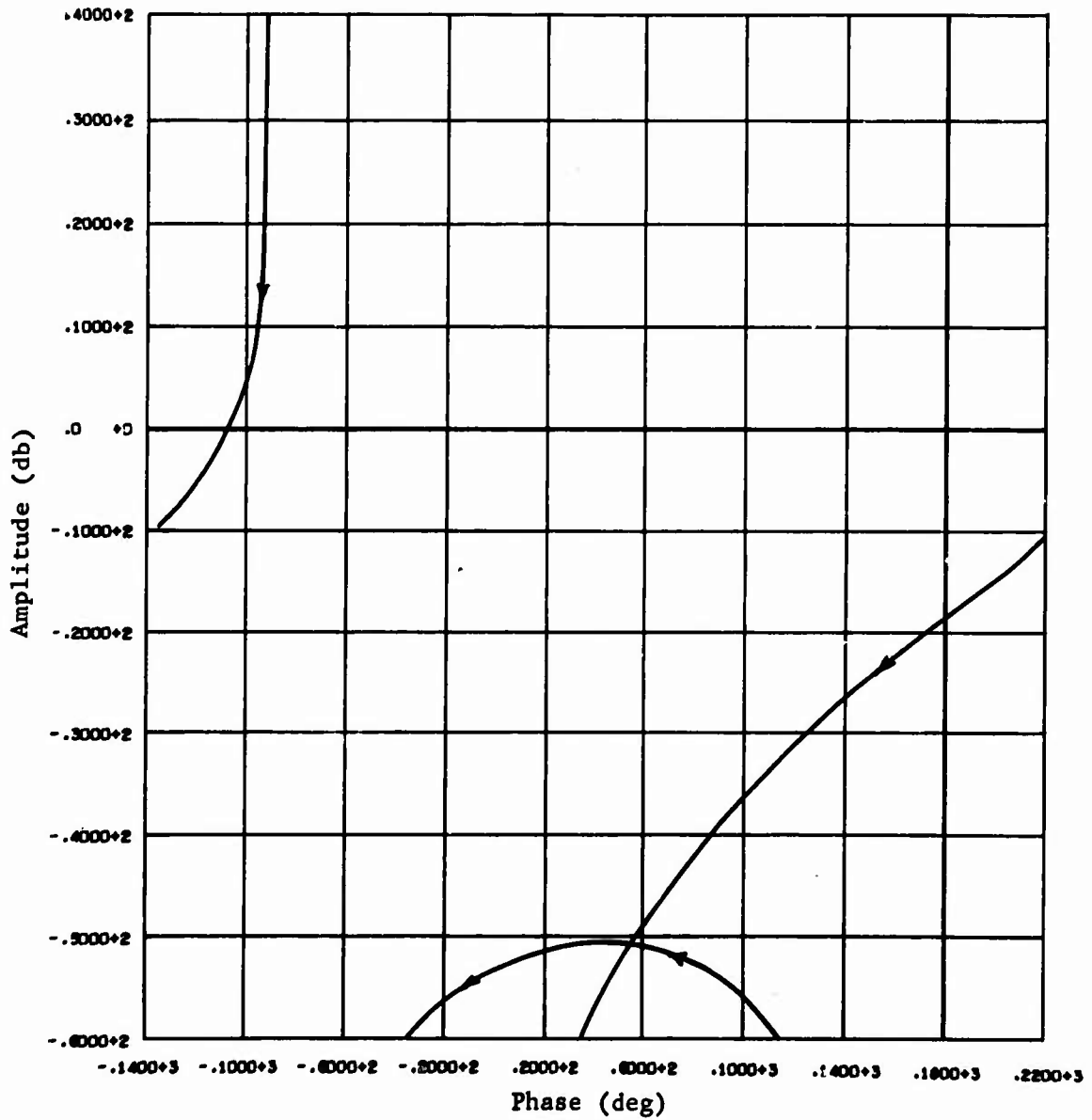
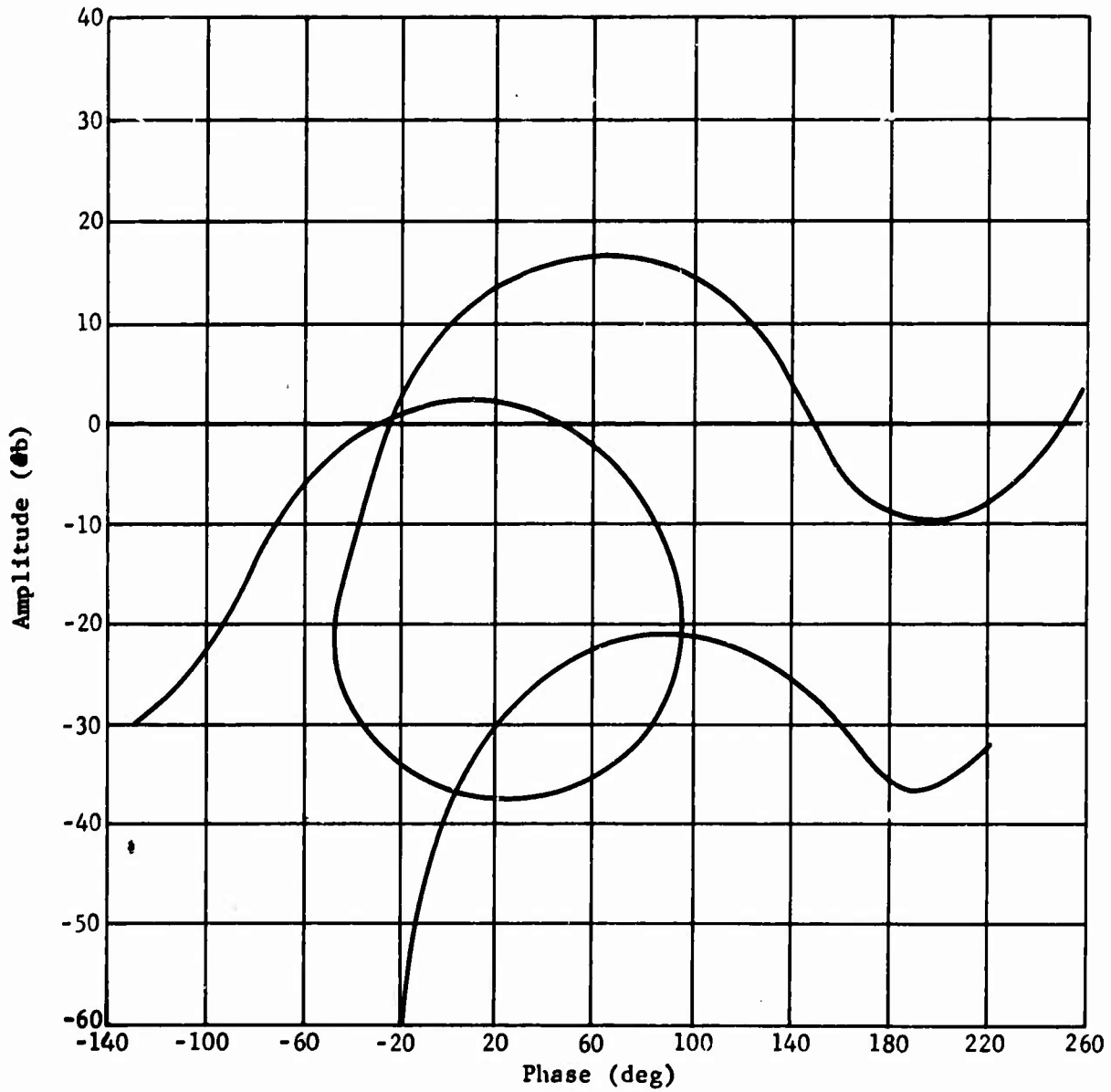

Fig. C-48 Open Loop Frequency Response, Roll Axis, Stage II



Flight Control System Configuration

Channel	Gain	Filter Configuration
Displacement	$K_D = 0$	$\frac{K_{R2}}{(1 + s/15)^2}$ $\frac{K'_{R2}}{(1 + s)}$
Stage I Rate	$K_{R1} = 0$	
Stage II Rate	$K_{R2} = 0.25$	
	$K'_{R2} = 0.40$	

Fig. C-49 Open Loop Frequency Response, Roll Axis (0 sec)

SSD-CR-64-32

Flight Control Configuration

Channel	Gain	Filter Configuration
Displacement	$K_D = 0$	
Stage I Rate	$K_{R1} = 0$	
Stage II Rate	$K_{R2} = 0.25$	$\frac{K_{R2}}{(1 + s/15)^2}$
	$K'_{R2} = 0.4$	$\frac{K'_{R2}}{1 + s}$

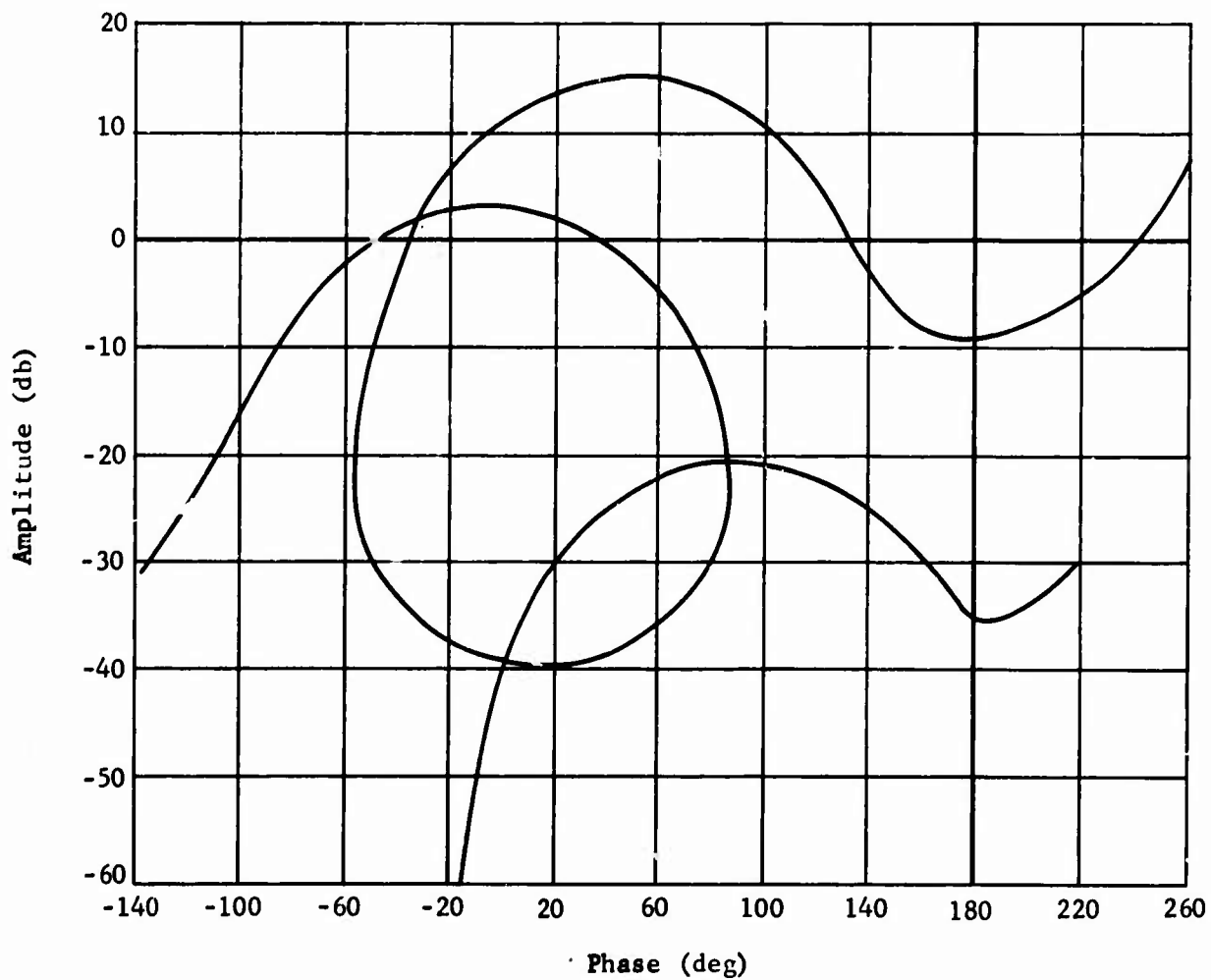

Fig. C-50 Open Loop Frequency Response, Roll Axis
(30 sec, BGC)

Flight Control System Configuration

Channel	Gain	Filter Configuration
Displacement	$K_D = 0$	
Stage I Rate	$K_{R1} = 0$	
Stage II Rate	$K_{R2} = 0.16$	$\frac{K_{R2}}{(1 + S/15)^2}$
	$K'_{R2} = 0.34$	$\frac{K'_{R2}}{1 + S}$

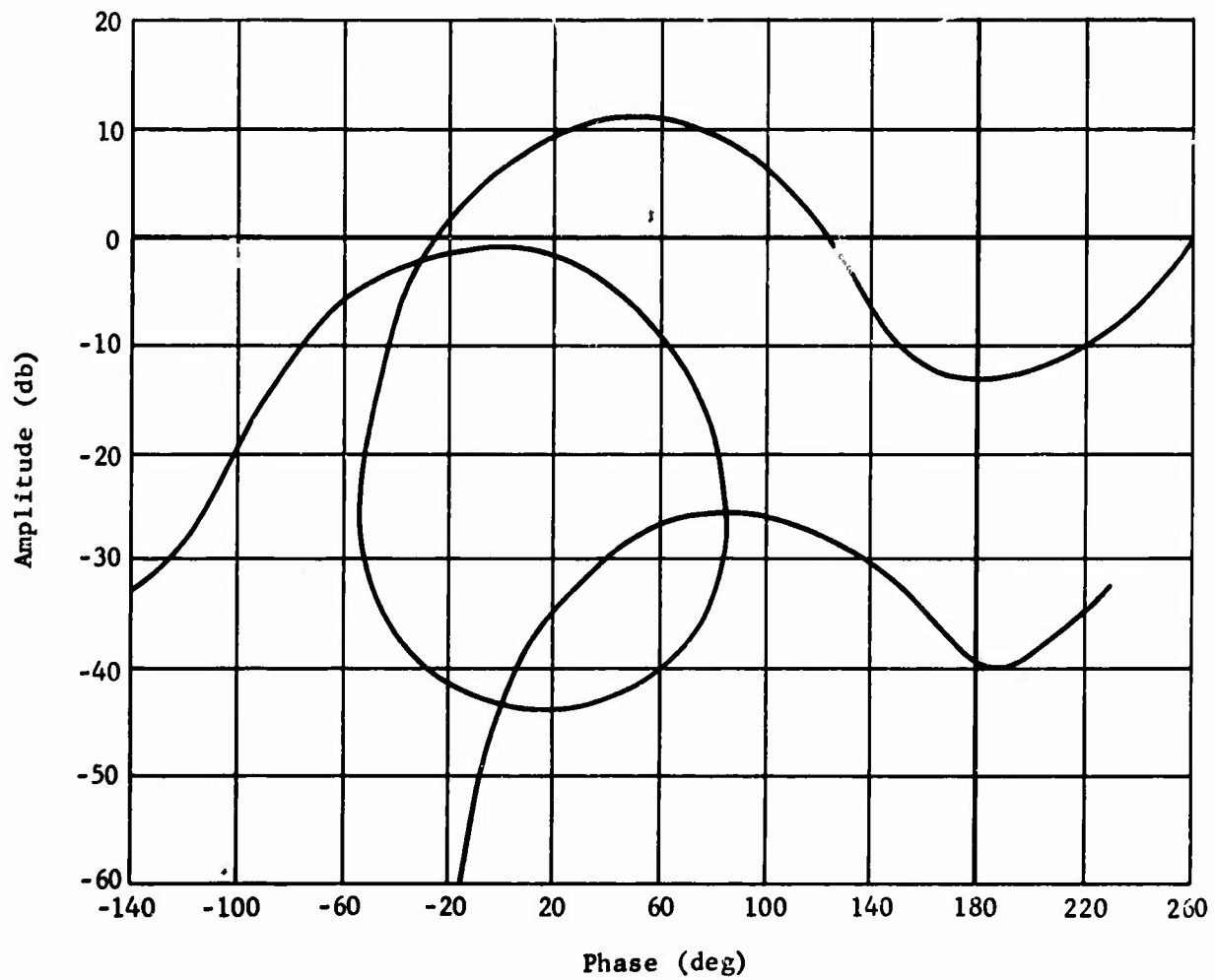

Fig. C-51 Open Loop Frequency Response, Roll Axis
(30 sec, AGC)

SSD-CR-64-32

Flight Control System Configuration

Channel	Gain	Filter Configuration
Displacement	$K_D = 0$	
Stage I Rate	$K_{R1} = 0$	
Stage II Rate	$K_{R2} = 0.16$	$\frac{K_{R2}}{(1 + S/15)^2}$
	$K'_{R2} = 0.34$	$\frac{K'_{R2}}{1 + S}$

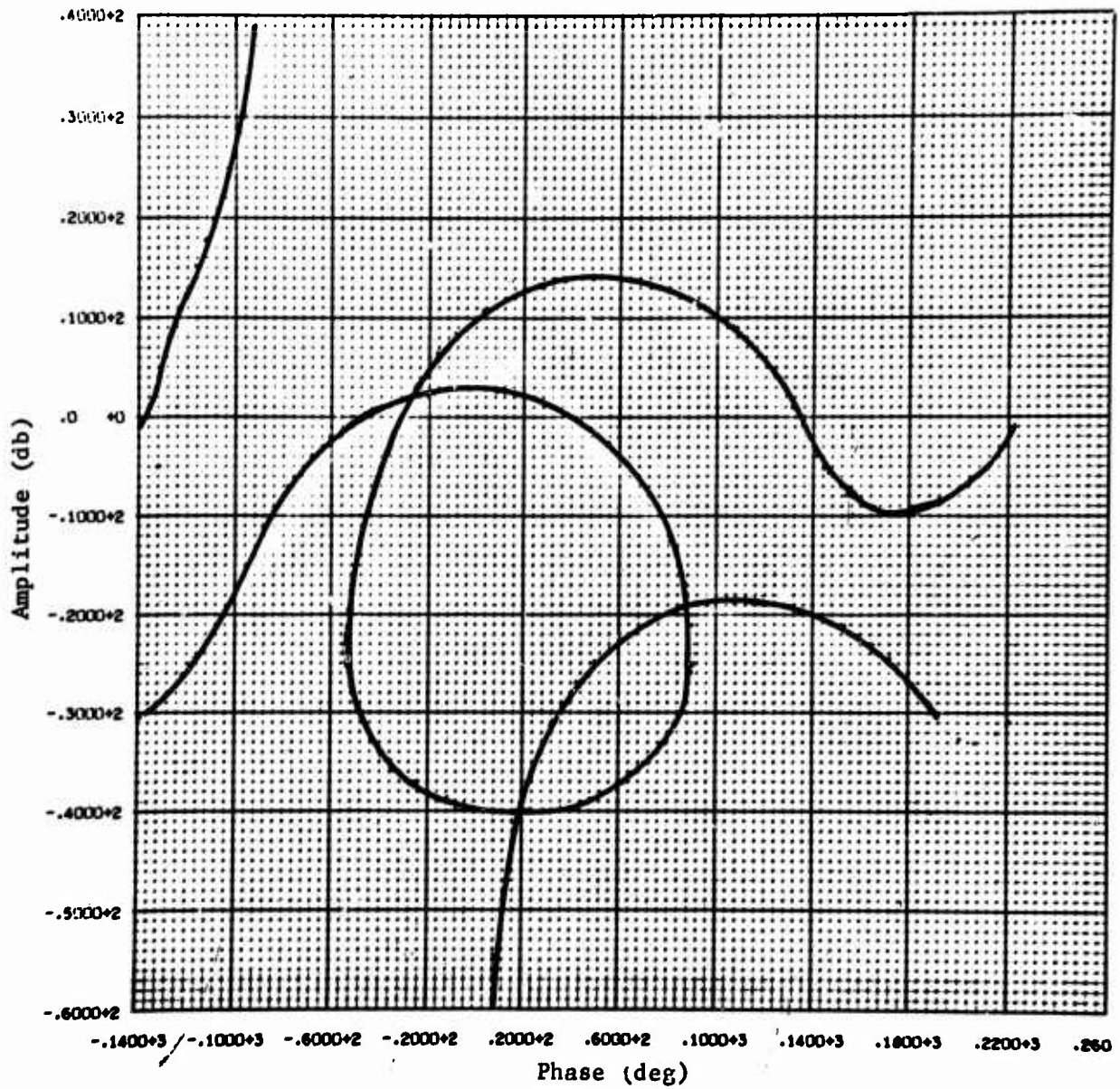

Fig. C-52 Open Loop Frequency Response, Roll Axis (60 sec)

Flight Control System Configuration

Channel	Gain	Filter Configuration
Displacement	$K_D = 0$	
Stage I Rate	$K_{R1} = 0$	
Stage II Rate	$K_{R2} = 0.16$	$\frac{K_{R2}}{(1 + s/15)^2}$
	$K'_{R2} = 0.34$	$\frac{K'_{R2}}{1 + s}$

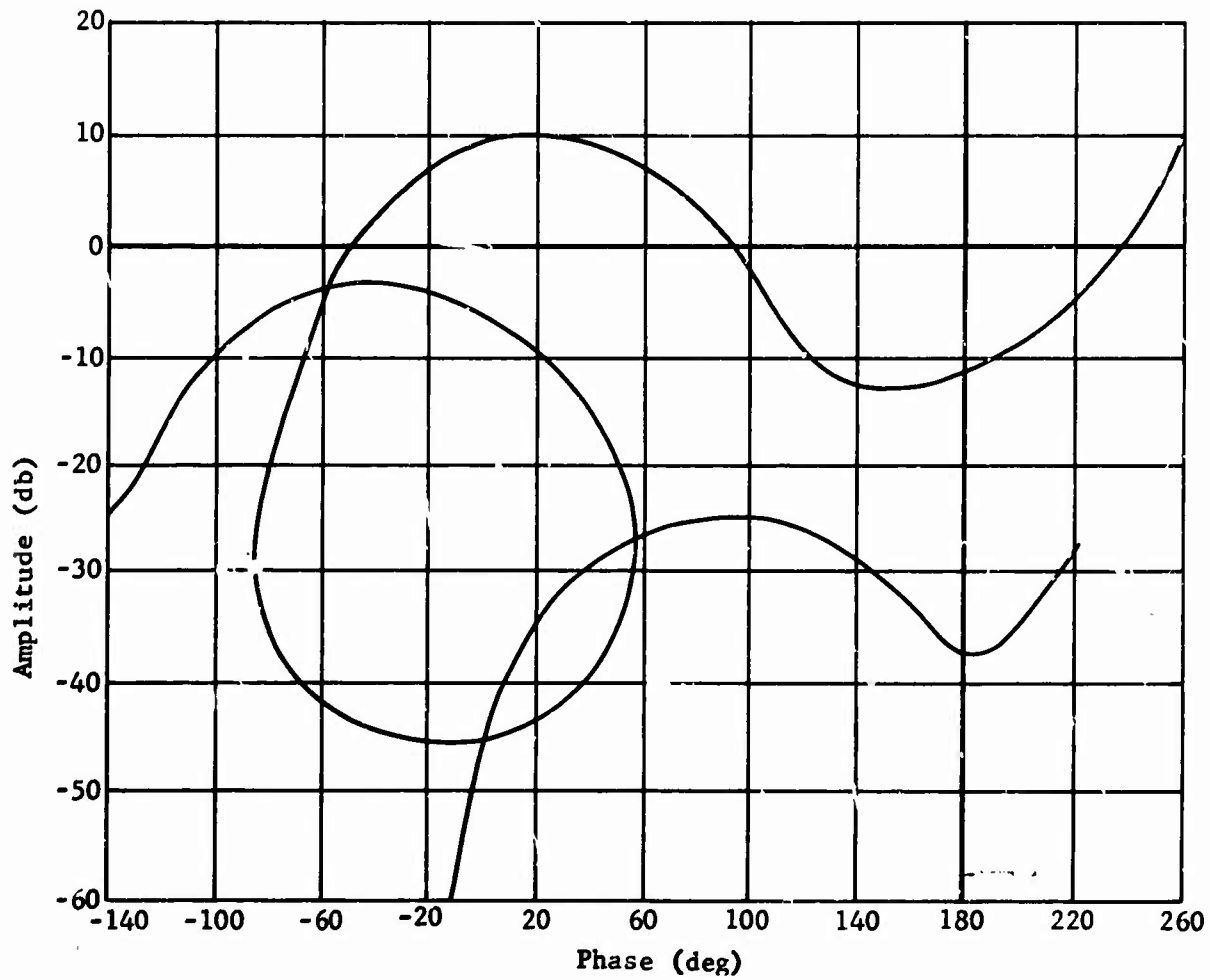

Fig. C-53 Open Loop Frequency Response, Roll Axis (80 sec, BGC)

Flight Control System Configuration

Channel	Gain	Filter Configuration
Displacement	$K_D = 0$	
Stage I Rate	$K_{R1} = 0$	
Stage II Rate	$K_{R2} = 0.12$	$\frac{K_{R2}}{(1 + s/15)^2}$
	$K_{R2} = 0.13$	$\frac{K'_{R2}}{(1 + s)}$

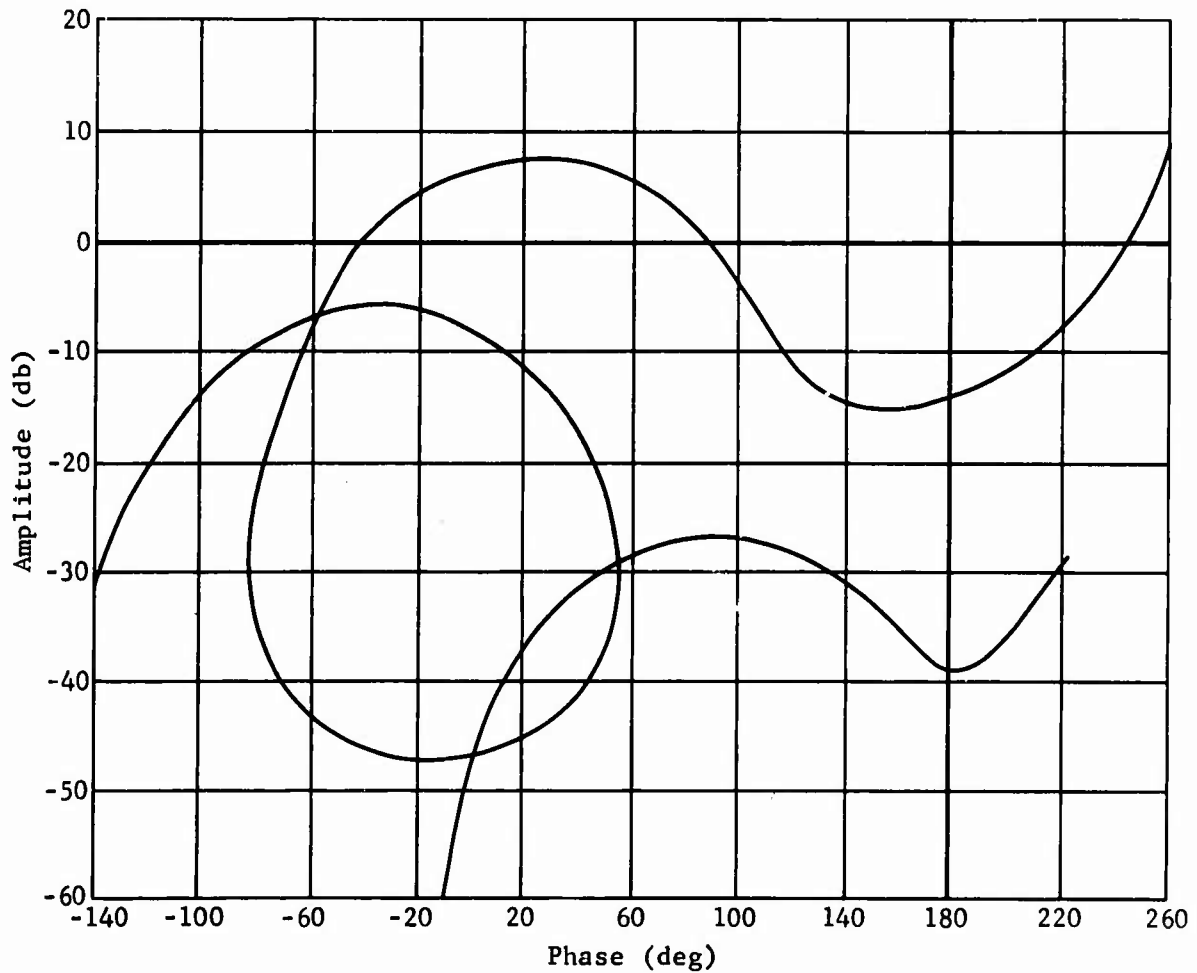

Fig. C-54 Open Loop Frequency Response, Roll Axis (80 sec, AGC)

Flight Control System Configuration

Channel	Gain	Filter Configuration
Displacement	$K_D = 0$	
Stage I Rate	$K_{R1} = 0$	
Stage II Rate	$K_{R2} = 0.12$	$\frac{K_{R2}}{1 + S/15}$
	$K'_{R2} = 0.13$	$\frac{K'_{R2}}{1 + S}$

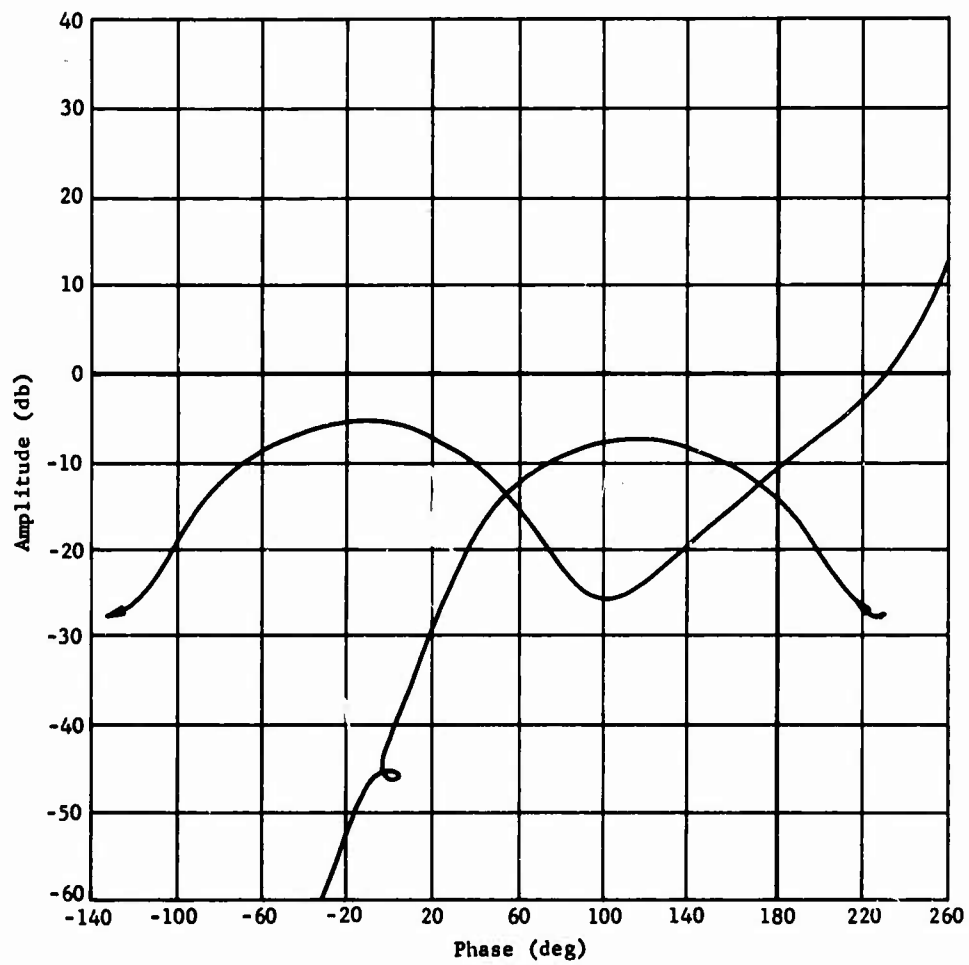

Fig. C-55 Open Loop Frequency Response, Roll Axis (105 sec)

Terminology unique to this appendix is as follows:

Abbreviations;

BGC Before gain change

AGC After gain change

Axis Scaling;

.XYZ+n = .XYZx10ⁿ

Symbols;

$\dot{\theta}_{RB}$ Rigid body angular rate about pitch axis

$\dot{\psi}_{RB}$ Rigid body angular rate about yaw axis

APPENDIX D

BROADER PIBOL STAGE 0 RESULTS

Open Loop Frequency Response, Stage 0 Pitch Axis, 30 sec (Fig. D-1)
Open Loop Frequency Response, Stage 0 Pitch Axis, 60 sec (Fig. D-2)
Open Loop Frequency Response, Stage 0 Pitch Axis, 80 sec (Fig. D-3)
Transient Response, Stage 0 Pitch Axis, 30 sec (Fig. D-4)
Transient Response, Stage 0 Pitch Axis, 60 sec (Fig. D-5)
Transient Response, Stage 0 Pitch Axis, 80 sec, (Fig. D-6)
Terminology

Flight Control System Configuration

Channel	Gain	Filter Configuration
Displacement	$K_D = 0$	
Stage I Rate	$K_{R1} = 0.64$	$\frac{1}{(1 + s/40)}$
Stage II Rate	$K_{R2} = 0.36$	$\frac{1}{(1 + s/30)^2}$
Acceleration	$K_A = 0.00075$	$\frac{1}{(1 + s/5)(1 + s/3)(1 + s/10)}$
Velocity	$K_V = 0$	

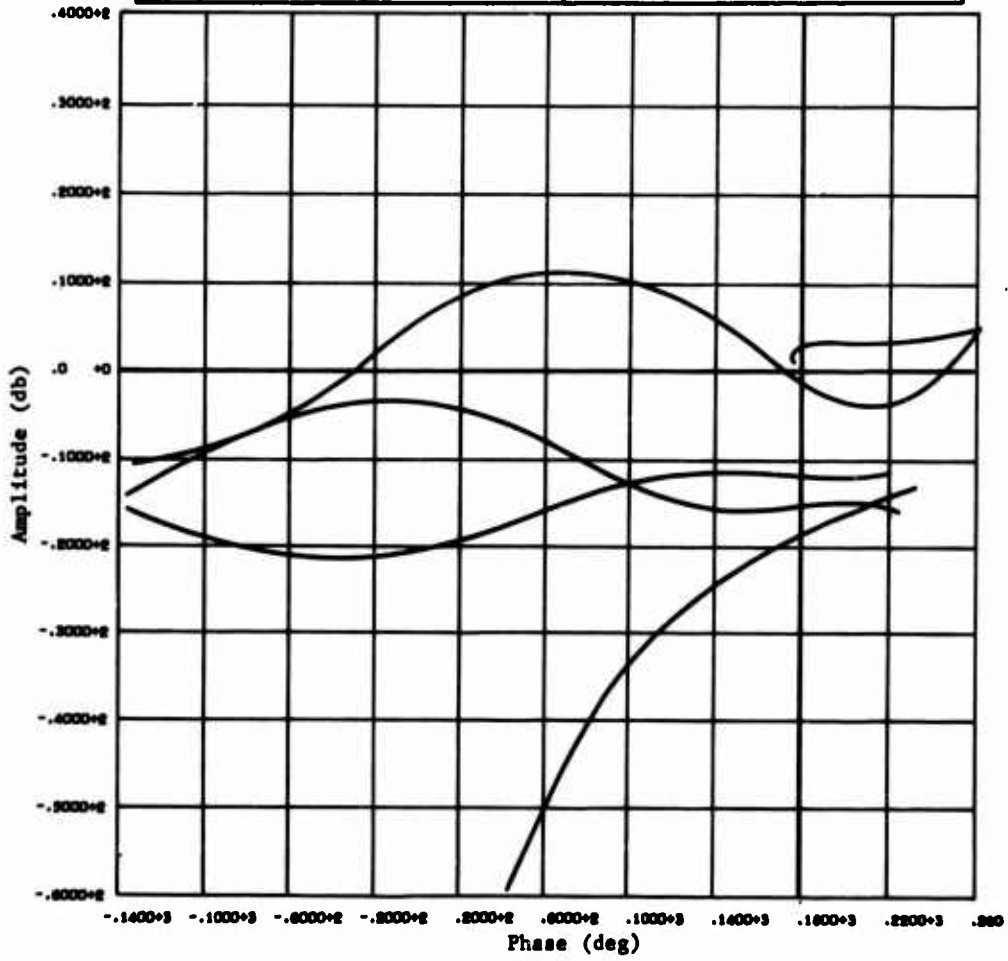

Fig. D-1 Open Loop Frequency Response, Stage 0 Pitch Axis (30 sec)

Flight Control System Configuration

Channel	Gain	Filter Configuration
Displacement	$K_D = 0$	
Stage I Rate	$K_{R1} = 0.64$	$\frac{1}{(1 + S/40)}$
Stage II Rate	$K_{R2} = 0.36$	$\frac{1}{(1 + S/30)^2}$
Acceleration	$K_A = 0.00075$	$\frac{1}{(1 + S/5)(1 + S/3)(1 + S/10)}$
Velocity	$K_V = 0$	

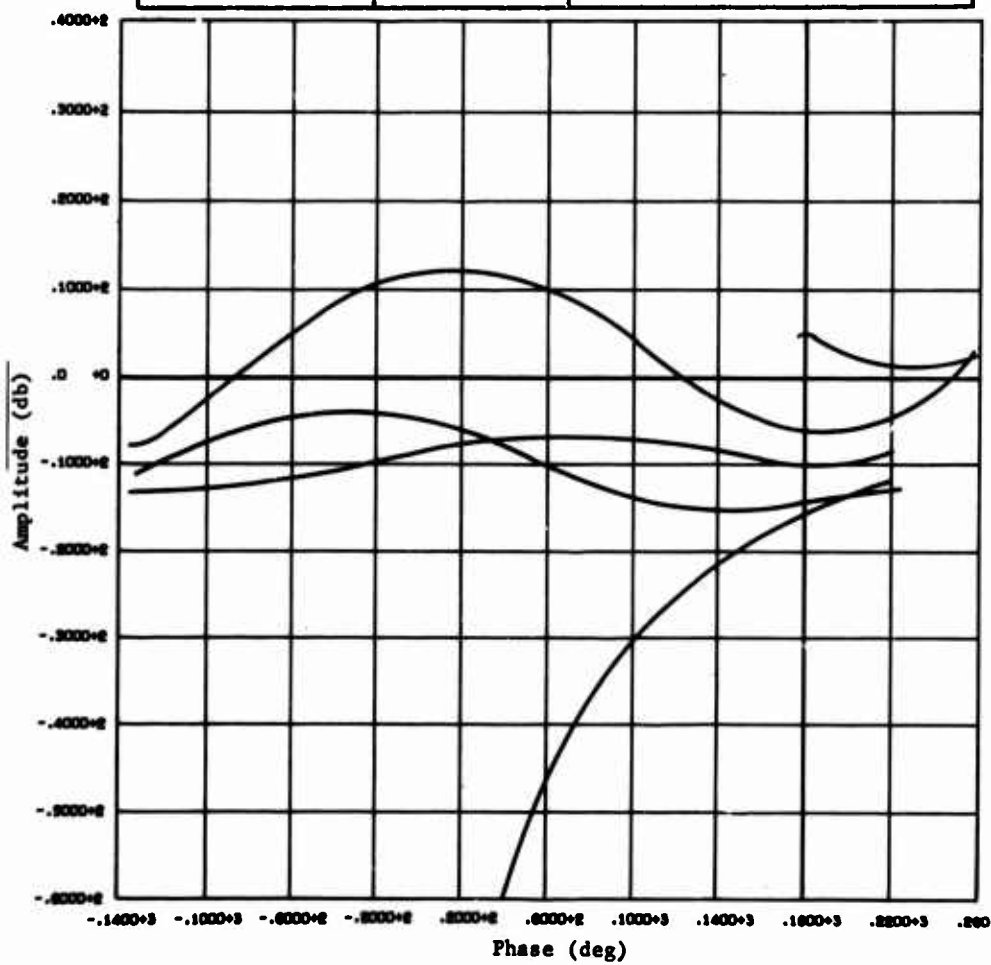

Fig. D-2 Open Loop Frequency Response, Stage 0 Pitch Axis (60 sec)

Flight Control System Configuration

Channel	Gain	Filter Configuration
Displacement	$K_D = 0$	
Stage I Rate	$K_{R1} = 0.64$	$\frac{1}{(1 + s/40)}$
Stage II Rate	$K_{R2} = 0.36$	$\frac{1}{(1 + s/30)^2}$
Acceleration	$K_A = 0.0075$	$\frac{1}{(1 + s/5)(1 + s/3)(1 + s/10)}$
Velocity	$K_V = 0$	

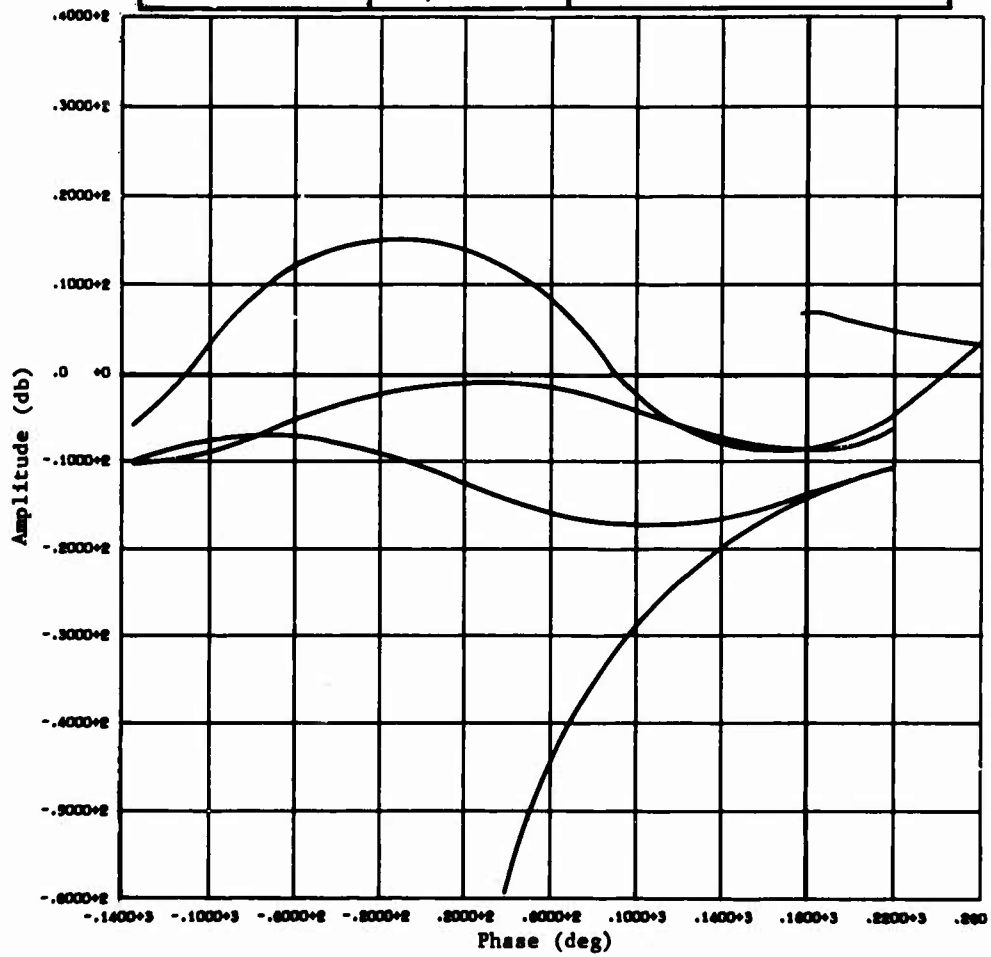

Fig. D-3 Open Loop Frequency Response, Stage 0 Pitch Axis (80 sec)

Flight Control System Configuration

Channel	Gain	Filter Configuration
Displacement	$K_D = 0$	
Stage I Rate	$K_{R1} = 0.64$	$\frac{1}{(1 + S/40)}$
Stage II Rate	$K_{R2} = 0.36$	$\frac{1}{(1 + S/30)^2}$
Acceleration	$K_A = 0.00075$	$\frac{1}{(1 + S/5)(1 + S/3)(1 + S/10)}$
Velocity	$K_V = 0$	

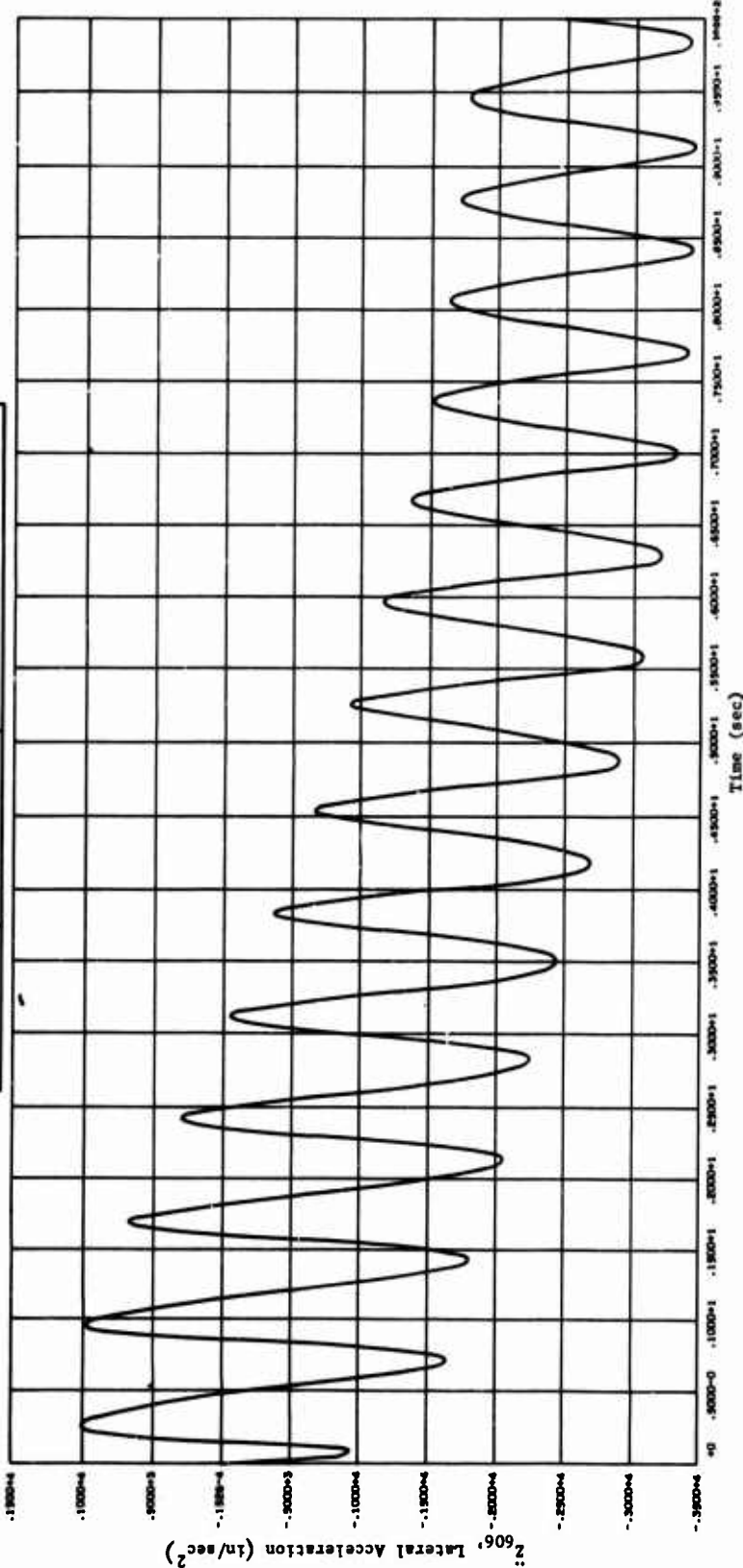

Fig. D-4 Transient Response, Stage 0 Pitch Axis (30 sec)

Flight Control System Configuration

Channel	Gain	Filter Configuration
Displacement	$K_D = 0$	
Stage I Rate	$K_{P1} = 0.64$	$\frac{1}{(1 + S/40)}$
Stage II Rate	$K_{P2} = 0.36$	$\frac{1}{(1 + S/30)^2}$
Acceleration	$K_A = 0.00075$	$\frac{1}{(1 + S/5)(1 + S/3)(1 + S/10)}$
Velocity	$K_V = 0$	

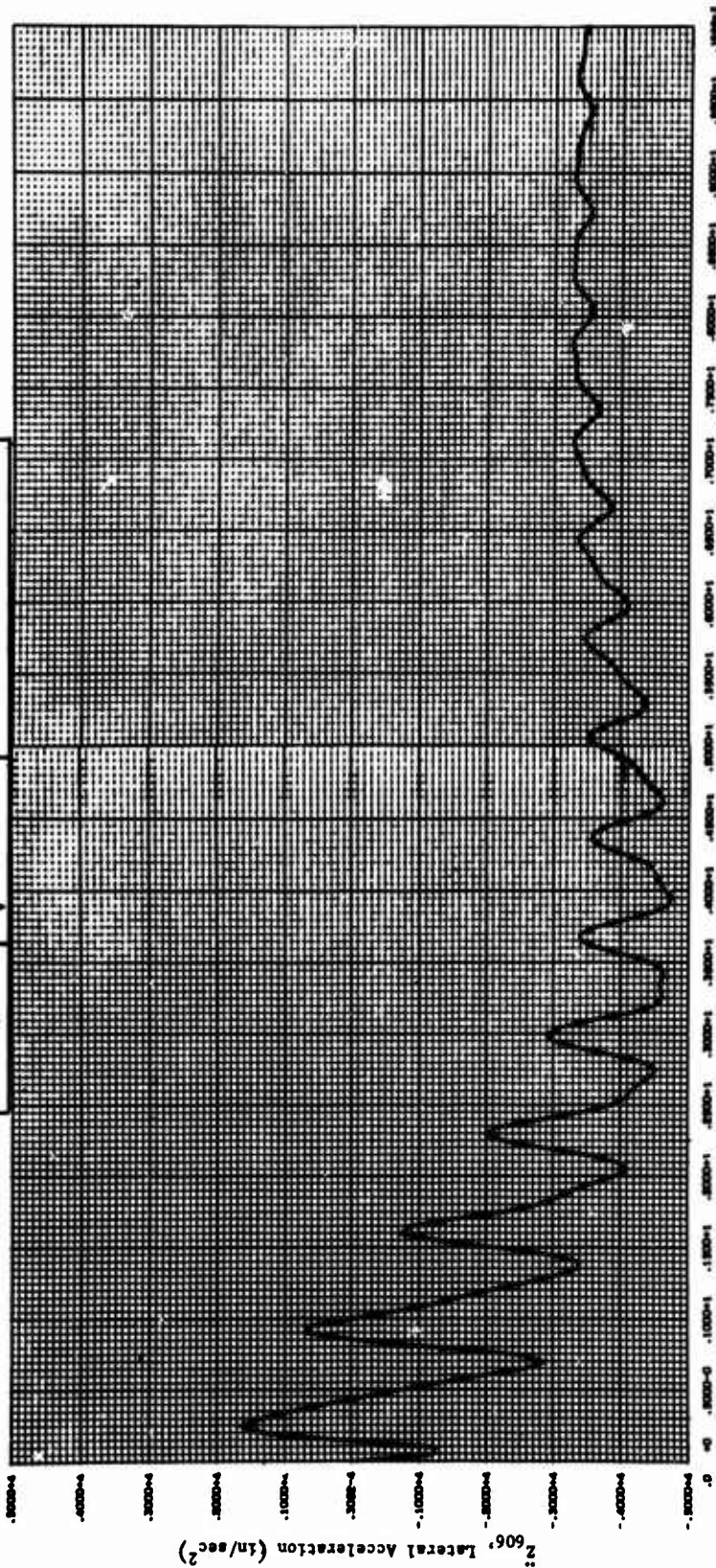

Fig. D-5 Transient Response, Stage 0 Pitch Axis (60 sec)

Flight Control System Configuration

Channel	Gain	Filter Configuration
Displacement	$K_D = 0$	
Stage I Rate	$K_{R1} = 0.64$	$\frac{1}{(1 + S/40)}$
Stage II Rate	$K_{R2} = 0.36$	$\frac{1}{(1 + S/30)^2}$
Acceleration	$K_A = 0.00075$	$\frac{1}{(1 + S/5)(1 + S/3)(1 + S/10)}$
Velocity	$K_V = 0$	

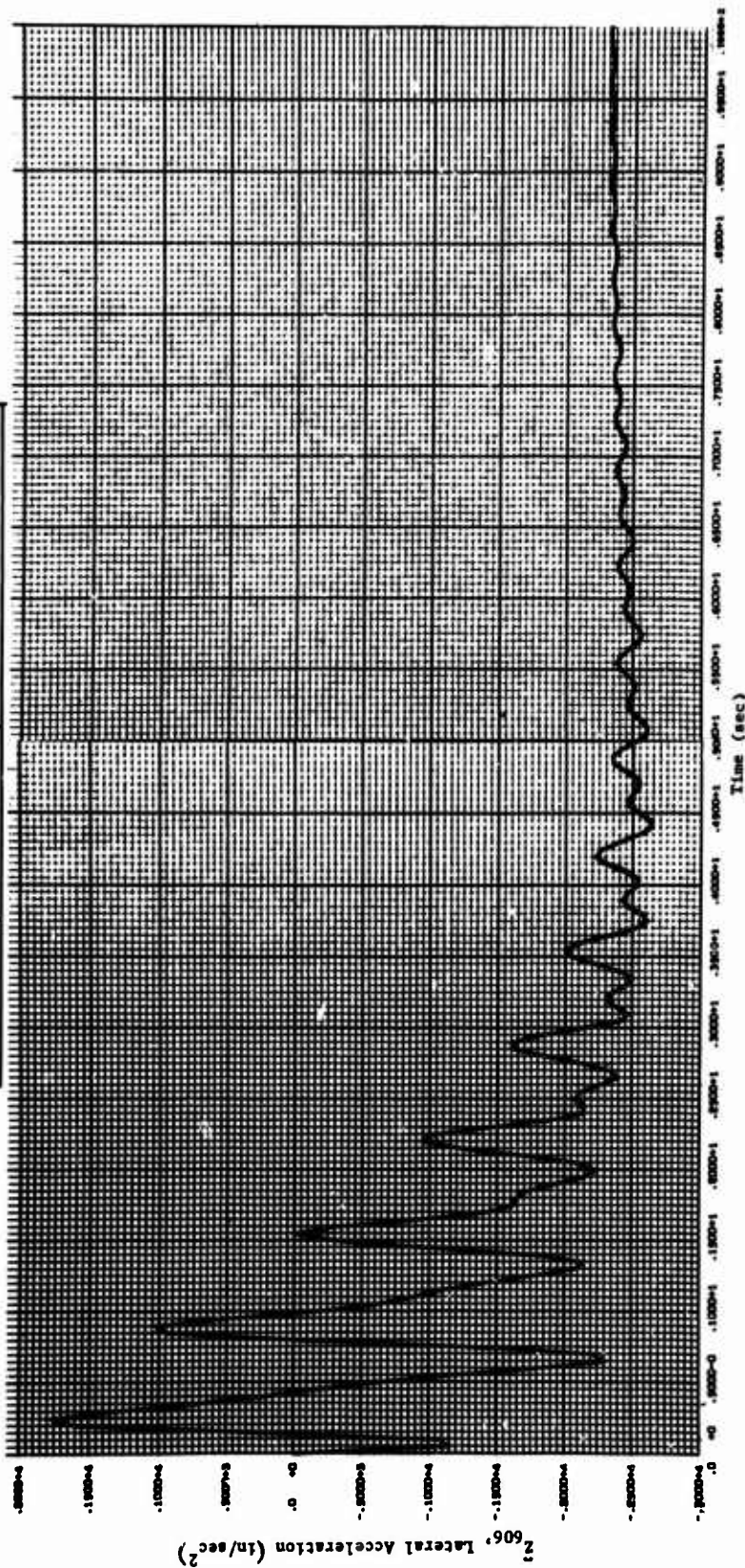

Fig. D-6 Transient Response, Stage 0 Pitch Axis (80 sec)

Terminology unique to this appendix is as follows:

Axis Scaling;

$$.XYZ+n = .XYZ \times 10^n$$

Symbols;

\ddot{z}_{606} Lateral acceleration in pitch plane at
vehicle Sta 606.

SSD-CR-64-32

E-1

APPENDIX E

TOLERANCE CONSIDERATIONS

Table E-1 Basic PIBOL Tolerance Sensitivities, Stage 0 Handling Characteristics at 60 Sec

Parameter	Symbol	Tolerance Applied	Effect of Tolerance (1)	
			On ω_n	On $2\zeta\omega_n$
Equivalent Displacement Channel Gain	K_{RD}	+ 15%	- 0.4	+ 0.8
		- 15%	+ 0.2	- 0.9
Stage I Rate Channel Gain	K_{R1}	+ 10%	+ 1.5	+ 0.5
		- 10%	- 1.2	- 0.6
Stage II Rate Channel Gain	K_{R2}	+ 10%	- 1.3	+ 0.3
		- 10%	+ 1.1	- 0.3
Integrator Time Constant	τ	+ 12%	X	- 0.1
		- 12%	X	+ 0.1
Equivalent Displacement Channel Filter Break Frequency	ω_{RD}	+ 12%	- 0.9	- 0.1
		- 12%	+ 0.1	+ 0.1
Thrust	T	+ 5%	X	X
		- 5%	X	X
Center of Gravity	CG	+ 25 in.	+ 1.0	+ 0.16
		- 25 in.	- 0.8	- 0.20
Inertia	I_{yy}	+ 10%	- 2.0	- 0.3
		- 10%	+ 3.0	+ 0.25
Mass	M	+ 10%	X	X
		- 10%	X	X
Normal Force Coefficient	C_{Nx}	+ 14%	X	X
		- 14%	X	X
Moment Coefficient	C_{Mx}	+ 14%	- 1.2	- 0.1
		- 14%	+ 1.5	+ 0.15

Note: (1) + signifies increase in handling parameter,
- signifies decrease in handling parameter,
X signifies no effect.

1. Taking a statistical summation (RSS) of the effects of tolerances (considering effects with a - sign).
2. Effects on ω_n^2 ; $RSS = \sqrt{10.18} \approx +3.4$.
3. Effects on $2\zeta\omega_n$; $RSS = \sqrt{1.42} \approx +1.2$.

SSD-CR-64-32

Table E-2 Broader PIBOL Tolerance Sensitivities, Stage O Handling Characteristics at 60 Sec

Parameter	Symbol	Tolerance Applied	Effect of Tolerance (1)	
			On ω_n	On $2\zeta\omega_n$
Stage I Rate Channel Gain	K_{R1}	+ 10% - 10%	+ 0.06 - 0.20	+ 0.07 - 0.30
Stage II Rate Channel Gain	K_{R2}	+ 10% - 10%	+ 0.03 - 0.12	+ 0.04 - 0.20
Acceleration Channel Gain	K_A	+ 10% - 10%	+ 0.18 - 0.16	- 0.07 + 0.08
Thrust	T	+ 5% - 5%	- 0.13 + 0.11	- 0.14 + 0.02
Center of Gravity	CG	+ 25 in. - 25 in.	+ 0.08 X	+ 0.02 - 0.07
Inertia	I_{yy}	+ 10% - 10%	+ 0.07 - 0.08	+ 0.04 - 0.03
Mass	M	+ 10% - 10%	X + 0.11	X - 0.03
Normal Force Coefficient	$C_{N\alpha}$	+ 14% - 14%	+ 0.10 - 0.14	- 0.02 + 0.02
Moment Coefficient	$C_{M\alpha}$	+ 14% - 14%	- 0.03 + 0.17	- 0.04 + 0.09
<p>Note: (1) + signifies increase in handling parameter, - signifies decrease in handling parameter, X signifies no effect.</p>				
<p>1. Taking a statistical combination (RSS) of the effects of tolerances (considering the effects with a - sign). 2. Effects on ω_n^2; RSS = $\sqrt{0.1238} \approx \pm 0.35$. 3. Effects on $2\zeta\omega_n$; RSS = $\sqrt{0.1631} \approx \pm 0.40$.</p>				

Table E-3 Basic PIBOL Tolerance Sensitivities, Stage 0 Pitch Axis, Stability Margins at 60 Sec

Parameters	Symbol	Tolerance Applied (%)	Effect of Tolerance (1)	
			On Margin on Front Side of First Structural Mode (deg)	On Margin on Back Side of First Structural Mode (deg)
Equivalent Displacement Channel Gain	K_{RD}	+ 15	+ 4*	- 2
		- 15	- 4	+ 1*
Stage I Rate Channel Gain	K_{R1}	+ 10	- 8	+ 7*
		- 10	+ 8*	- 9
Stage II Rate Channel Gain	K_{R2}	+ 10	+ 6*	- 15
		- 10	- 4	- 5
Integrator Time Constant	τ	+ 12	- 2	- 7
		- 12	+ 5*	- 7
Equivalent Displacement Channel Filter Break Frequency	ω_{RD}	+ 12	- 4	- 4
		- 12	+ 6*	- 9
Stage I Rate Channel Break Frequency	ω_{R1} (1)	+ 12	- 1	+ 1* (2)
		- 12	+ 1* (2)	X
Stage II Rate Channel Break Frequency	ω_{R2} (1)	+ 12	+ 4* (2)	- 3
		- 12	- 2	- 3
Thrust	T	+ 5	+ 2*	+ 1*
		- 5	- 2	- 1
Slope of First Mode at Equivalent Gimbal	ϕ_1 (1316)	+ 20	- 2	+ 1*
		- 20	+ 2*	- 1
Deflection of First Mode at Equivalent Gimbal	h_1 (1316)	+ 20	+ 2*	+ 1*
		- 20	- 3	- 3
Slope of First Mode at Stage I Gyro	ϕ_1 (887)	+ 20	- 8	+ 9*
		- 20	+ 14*	- 13
Slope of First Mode at Stage II Gyro	ϕ_1 (320)	+ 20	+ 12*	- 10
		- 20	- 12	+ 9*
First Mode Frequency	ω_1	+ 7	- 8	+ 3*
		- 7	+ 8*	- 3

Note: (1) + signifies decrease in margin, - signifies improvement in margin by the amount specified, X signifies no change.
(2) Stage I and Stage II filter variation is for a single filter, and must be considered twice for the configuration used.

The following parameters were also considered, but had no noticeable effect on the margins: Center of gravity (CG), ± 25 in.; moment of inertia (I_{yy}), $\pm 10\%$; mass (M), $\pm 10\%$; normal force coefficient ($C_{N\alpha}$), $\pm 14\%$; moment coefficient ($C_{M\alpha}$), $\pm 14\%$. The root-sum-square value of the degradations (*) is as follows, using the ω_{R1} and ω_{R2} effects twice:

On the front side margin, $RSS = \sqrt{623} \approx 25$ deg.
On the back side margin, $RSS = \sqrt{226} \approx 15$ deg.

SSD-CR-64-32

Table E-4 Effects of Tolerances on Stage I Handling Characteristics

The equations defining the Stage I handling characteristics were given in Chap. III.A.2., and are:

$$\omega_n^2 = K_D \frac{TLg}{I_{yy}}$$

$$2\zeta\omega_n = K_R \frac{TLg}{I_{yy}}$$

For the recommended Stage I system, $K_D = 0$ and $K_R = 0.78$ sec at Stage I start, where the handling characteristics obtained are nearest the handling characteristic boundaries.

The nominal parameters and the tolerances considered were:

$$K_D = 0,$$

$$K_R = 0.78 \text{ sec } \pm 10\%,$$

$$T = 0.473 \times 10^6 \text{ lb } \pm 5\%,$$

$$Lg = 569 \pm 25 \text{ in.},$$

$$I_{yy} = 114.6 \times 10^6 \text{ lb-in.-sec}^2 \pm 10\%.$$

The nominal handling characteristic, $2\zeta\omega_n$, is:

$$2\zeta\omega_n = (0.78 \text{ sec}) \frac{(0.473 \times 10^6 \text{ lb})(569 \text{ in.})}{(114.6 \times 10^6 \text{ lb-in.-sec}^2)} = 1.83 \text{ 1/sec.}$$

The variation in $2\zeta\omega_n$ for each variable is:

$$\text{For } K_R (\pm 10\%); \pm 0.183 \text{ 1/sec,}$$

$$\text{For } T (\pm 5\%); \pm 0.092 \text{ 1/sec,}$$

$$\text{For } Lg (\pm 25 \text{ in.}); \pm 0.081 \text{ 1/sec,}$$

$$\text{For } I_{yy} (\pm 10\%); \pm 0.167 \text{ 1/sec.}$$

The root-sum-square of these tolerance sensitivities is:

$$(\overline{0.183^2} + \overline{0.092^2} + \overline{0.081^2} + \overline{0.167^2})^{1/2} \approx 0.28 \text{ 1/sec.}$$

The variation of $2\zeta\omega_n$, about the nominal, due to the tolerances considered is:

$$2\zeta\omega_n = 1.83 \pm 0.28 \text{ 1/sec.}$$

Table E-5 Effects of Tolerances on Stage II Handling Characteristics

For the recommended Stage II system, $K_D = 0$ and $K_R = 0.3$ sec at Stage II start, where the handling characteristics obtained are nearest the handling characteristic boundaries.

The nominal parameters and the tolerances considered are:

$$K_D = 0,$$

$$K_R = 0.3 \text{ sec } \pm 10\%,$$

$$T = 0.1 \times 10^6 \text{ lb } \pm 5\%,$$

$$L_g = 260 \pm 25 \text{ in.},$$

$$I_{yy} = 12.2 \times 10^6 \text{ lb-in.-sec}^2 \pm 10\%.$$

The nominal handling characteristic, $2\zeta\omega_n$, is:

$$2\zeta\omega_n = (0.3 \text{ sec}) \frac{(0.1 \times 10^6 \text{ lb})(260 \text{ in.})}{(12.2 \times 10^6 \text{ lb-in.-sec}^2)} = 0.639 \text{ 1/sec.}$$

The variation in $2\zeta\omega_n$ for each variable is:

$$\text{For } K_R \text{ } (\pm 10\%); \pm 0.0639 \text{ 1/sec,}$$

$$\text{For } T \text{ } (\pm 5\%); \pm 0.0318 \text{ 1/sec,}$$

$$\text{For } L_g \text{ } (\pm 25 \text{ in.}); \pm 0.0615 \text{ 1/sec,}$$

$$\text{For } I_{yy} \text{ } (\pm 10\%); \pm 0.058 \text{ 1/sec.}$$

The root-sum-square of these tolerance sensitivities is:

$$(\overline{0.0639^2} + \overline{0.0318^2} + \overline{0.0615^2} + \overline{0.058^2})^{1/2} = \pm 0.11 \text{ 1/sec.}$$

The variation of $2\zeta\omega_n$ about the nominal, due to the tolerance considered, is:

$$2\zeta\omega_n = 0.639 \pm 0.11 \text{ 1/sec.}$$

SSD-CR-64-32

Table E-6 Broader PIBOL Tolerance Sensitivities, Stage 0 Pitch Axis, Stability Margins at 60 Sec

Parameter (3)	Symbol	Tolerance Applied (%)	Effect of Tolerance (1)	
			On Margin on Front Side of First Structural Mode (deg)	On Margin on Back Side of First Structural Mode (deg)
Stage I Rate Channel Gain	K_{R1}	+ 10 - 10	- 16 + 22*	+ 16* - 28
Stage II Rate Channel Gain	K_{R2}	+ 10 - 10	+ 54* - 14	- 54 X
Acceleration Channel Gain	K_A	+ 10 - 10	- 18 - 8	+ 6* - 2
Stage I Rate Channel Filter Break Frequency	ω_{R1}	+ 12 - 12	- 30 - 18	+ 16* + 12
Stage II Rate Channel Filter Break Frequency	ω_{R2}	+ 12 - 12	+ 4* (2) + 2	+ 1* (2) X
Acceleration Channel, 3-rad Filter Break Frequency	ω_{A3}	+ 12 - 12	+ 4* - 8	X + 6*
Acceleration Channel, 5-rad Filter Break Frequency	ω_{A5}	+ 12 - 12	+ 4* - 6	- 12 - 4
Acceleration Channel, 10-rad Filter Break Frequency	ω_{A10}	+ 12 - 12	+ 4* - 4	- 10 - 4
Thrust	T	+ 5 - 5	+ 2* - 2	+ 2* - 2
Inertia	I_{yy}	+ 10 - 10	- 2 + 2*	- 4 + 4*
Slope of First Mode at Equivalent Thrust Deflection Point	ϕ_1 (1316)	+ 20 - 20	- 2 + 4*	X - 4
Deflection of First Mode at Equivalent Gimbal	h_1 (1316)	+ 20 - 20	+ 6* - 10	X - 2
Slope of First Mode at Stage I Gyro	ϕ_1 (887)	+ 20 - 20	- 26 + 54*	+ 24* - 62
Slope of First Mode at Stage II Gyro	ϕ_1 (320)	+ 20 - 20	+ 54* - 40	- 46 + 31*
First Mode Frequency	ω_1	+ 7 - 7	- 2 + 2*	- 2 + 2*
Deflection of First Mode at Accelerometer	h_1 (364)	+ 20 - 20	- 10 + 8*	+ 3* - 4
<p>Note: (1) + signifies decrease in margin, - signifies improvement in margin, X signifies no change. (2) Stage II filter variation is for a single filter and must be considered twice for the configuration considered. (3) The following parameters were also considered but had no noticeable effect on the margins: Center of gravity (CG), ± 25 in.; mass (M), $\pm 10\%$; normal force coefficient (C_{N2}), $\pm 14\%$; moment coefficient (C_{M2}), $\pm 14\%$; first mode slope at the accelerometer, ϕ_1 (364), $\pm 20\%$.</p>				
<p>The root-sum-square value of the degradations (*) is as follows, using the ω_{R2} effect twice:</p> <p>On the front side margin, $RSS = \sqrt{9440} \approx 97$ deg.</p> <p>On the back side margin, $RSS = \sqrt{2155} \approx 46$ deg.</p>				

Table E-7 Stage I Tolerance Sensitivities, Pitch Axis-Stability Margins at Stage I Burnout

Parameters	Symbol	Tolerance Applied (%)	Effect of Tolerance (1)	
			On Margin on Front Side of First Structural Mode (deg)	On Margin on Back Side of First Structural Mode (deg)
Stage I Rate Channel Gain	K_{R1}	+ 10 - 10	- 2.2* + 1.0	- 2* + 2
Stage II Rate Channel Gain	K_{R2}	+ 10 - 10	- 0.5* + 0.5	+ 0.5 - 0.5*
Slope of First Mode at Stage II Rate Gyro	ψ_1 (320)	+ 20 - 20	- 8.0* + 6.0	- 6.0* + 4.5
Slope of First Mode at Stage I Rate Gyro	ψ_1 (887)	+ 20 - 20	- 10.0* + 15.2	- 12.0* + 4.2
Stage I Rate Channel Filter Break Frequency	ω_{R1}	+ 12 - 12	- 15.0* + 23.0	+ 10.0 + 4.0
Stage II Rate Channel	ω_{R2}	+ 12 - 12	+ 20.0 - 5.0*	+ 7.0 + 3.0

Note: (1) + signifies increase in margin, - signifies decrease in margin.

Only tolerances that significantly affect first mode margins were evaluated, based on previous Stage I tolerance studies.

The root-sum-square (RSS) of the degradations (*) is as follows:
 On the front side margin, $RSS = \sqrt{418} \approx 20.5$ deg,
 On the back side margin, $RSS = \sqrt{182} \approx 13.5$ deg.

SSD-CR-64-32

F-1

APPENDIX F

HARDWARE SPECIFICATION FOR
NEW EQUIPMENT AND
PAYLOAD INTERFACE REQUIREMENTS

The following specifications establish the requirements for new components for the recommended PIBOL system, requirements for the displacement gyros used in the basic PIBOL system (described in App H), and payload interface requirements.

1. SIGNAL TRANSFER SWITCH

Drawing No. PD72S0078, with the following revisions, adequately defines the switch required to transfer the functions of the booster inertial guidance system to the PIBOL system.

1.1 Add para 3.2.15 - Contact Current Rating - Contacts will be capable of carrying 0.5 amp continuously without damage.

1.2 Change para 3.3.1 to read:

Contact Voltage Drop - The contact voltage drop for any pair of contacts will not exceed 100 mv.

2. ACCELERATION SWITCH

This establishes the requirement for an acceleration switch for the Titan III/PIBOL system to perceive the termination of solid rocket thrust.

2.1 Performance Requirements

2.1.1 Output - The output of the acceleration switch will be a circuit closure when the acceleration along the input axis drops below a value that will be adjustable.

2.1.1.1 The circuit closure will be between two connector pins, one of which may be continuous with the negative side of the 28v dc power.

2.1.1.2 The switch circuit will support 60 volts when open.

2.1.1.3 The open switch will not conduct more than 15 ma.

2.1.1.4 The switch circuit will carry 0.5 amp continuously without damage.

2.1.1.5 The voltage drop on the closed switch circuit will be less than 1.4 volts.

2.1.2 Switch Setting - The acceleration magnitude at which switching occurs will be adjustable over a range of from 1.0 to 3.0 g.

2.1.3 Accuracy - The value of decreasing acceleration at which switching takes place will be repeatable within ± 0.1 g.

2.1.3.1 Dead Band - The value of increasing acceleration at which the switch opens will be greater than the value of decreasing acceleration at which closure occurs by not less than 0.5 g nor greater than 1.0 g.

2.1.3.2 Delay Time - When subjected to an acceleration that is decreased at a uniform rate, the switch closure will occur no more than 0.25 sec later than the time that the acceleration attains the switching value.

2.1.4 Power

2.1.4.1 Direct current may be supplied at from 25 to 31 volts. With superposed noise and ripple not greater than 2.5 volts peak, all transients will remain within 22.5 to 36.0v dc and return to the nominal conditions within 30 sec.

2.1.4.2 AC Power - 800 cps power is available. AC Voltage - $31.5 \pm 14\%$ volts rms square wave. Frequency - $800 \pm 2\%$. Wave Shape - The wave shape will be a square wave with the following allowable variations. Instantaneous voltage will be greater than 26.2 volts, but less than 37 volts. The rise time of both the leading and trailing edges of the square wave will be less than 15 μ sec when measured between points located at 10 and 90% of the peak to peak voltage.

2.1.5 Checkout - Provision for checkout will be made as follows: As an integral part of the acceleration switch, a self-test feature will be to impose a force equivalent to not less than 2 g on the sensitive element of the acceleration switch when a two-terminal circuit is energized with the dc voltage of para 1.4. This will insure that the acceleration switch is operated by the self-test feature when the switch is exposed to a 1-g acceleration.

2.2 Environment

2.2.1 Vibration - The acceleration switch will be designed to withstand random vibration as follows:

- 1) Remain open while exposed to random vibration with an acceleration spectral density corresponding to Curve A of Fig. F-1;

- 2) Meet all of the requirements of Sec 1. regarding accuracy while exposed to random vibration with an acceleration spectral density shown in Curve B of Fig. F-1 and survive 65 sec of vibration in accordance with Curve A.

2.2.2 Temperature - The switch will be capable of operation as required by Sec 1. when exposed to an ambient temperature of +20 to +165°F.

2.2.2.1 The unit will not be damaged by continuous storage at temperatures from -35 to +165°F.

2.2.3 Acceleration - The unit will not be damaged by acceleration of 10 g.

2.2.4 Shock - The unit will withstand shock in accordance with Fig. F-2 attached.

3. PIBOL SEQUENCER

3.1 General Requirements

3.1.1 Power - Operate from 28v dc power.

3.1.2 Environment - The sequencer must be able to function in the normal environment of Titan III Stage III.

3.2 Performance Requirements

3.2.1 The sequencer will have the capability of being reset and restarted by predetermined functions to generate an entirely new set of timed discrete switch closures during flight.

3.2.2 Output

3.2.2.1 The output of the sequencer will be 11 circuit closures individually timed from 0 to 198 sec as called out in Sec 3B.

3.2.2.2 The circuit closure will be between connector pins, one of which may be continuous with the negative side of the 28-volt power.

3.2.2.3 The switch circuit will support 60 volts when open.

3.2.2.4 The open switch will not conduct more than 15 ma.

3.2.2.5 The switch will carry 0.5 amp continuously without damage.

3.2.2.6 The voltage drop on the closed switch circuit will be less than 1.4 volts.

3.3 Accuracy - The timed outputs will be accurate to within ±1 sec.

4. DISPLACEMENT GYRO REQUIREMENTS FOR THE BASIC PIBOL SYSTEM USING GYROS (SEE SYSTEM DESCRIPTION, APP H, PART A)*

The displacement gyros used to provide attitude reference for the Basic PIBOL system are of the basic type used in the existing Titan III rate gyro system (PD96S0008), with the exceptions noted:

4.1 In PD96S0008, revise para 3.3.2.1 to read:

The gyro open-loop transfer function will be 44.5 mv rms ±15% output per deg displacement about the input axis throughout the range from +12 deg to -12 deg. This tolerance will apply under the most adverse combinations of tolerances specified for gyro temperature, signal generator excitation, and spin motor excitation.

4.2 Revise para 3.3.2.2 to read:

The open-loop gimbal travel will be limited at a value corresponding to not less than ±12 deg of input angle.

4.3 Revise para 3.3.2.3 to read:

The characteristic time will be less than 1 msec under the most adverse gyro temperature condition.

4.4 Delete para 3.3.2.5.

4.5 Delete para 3.3.2.6.

4.6 Revise para 3.3.2.9 to read:

The rate resolution, including stiction will be less than 60 deg/hr throughout the gimbal range.

*Not required in recommended system.

4.7 Revise para 3.3.5.2 to read:

The deviation of the torquer current from the least square line at any rate throughout the ranges specified in para 3.3.5.1 will not exceed ± 0.2 ma +5% of the normal current for the given rate.

4.8 Revise para 3.3.6.2 to read:

The deviation of the self-test torquer, . . .

(same as para 4.7).

5. PAYLOAD INTERFACE REQUIREMENTS

5.1 Steering Signals - The pitch, yaw, and roll signals from the pilot's controller(s) shall have the following characteristics:

5.1.1 Full scale output - the full scale output shall be ± 10 v dc.

5.1.2 Sensitivity - the exact sensitivity, from controller position to voltage output, shall be defined by the payload contractor, but shall be approximately 1/2v/deg.

5.1.3 Output impedance - the output impedance shall be less than 100 ohms, with the nominal value defined by the payload contractor and held within ± 10 ohms of that nominal.

5.1.4 The outputs to the booster shall be carried on a four-wire system; three signal wires and a single common; all four wires are to be isolated from the vehicle grounding system (to be grounded in the booster).

5.1.5 Null - The output, with the pilot's controllers at the null position shall be between ± 30 mv dc.

5.2 "Transfer to PIBOL" Command - The "Transfer to PIBOL" command shall be a closure of contacts to the Booster Accessory Power System 28v dc bus.

5.3 Stage II Shutdown Command

Same as 5.2

5.4 Stage III Shutdown Command

Same as 5.2

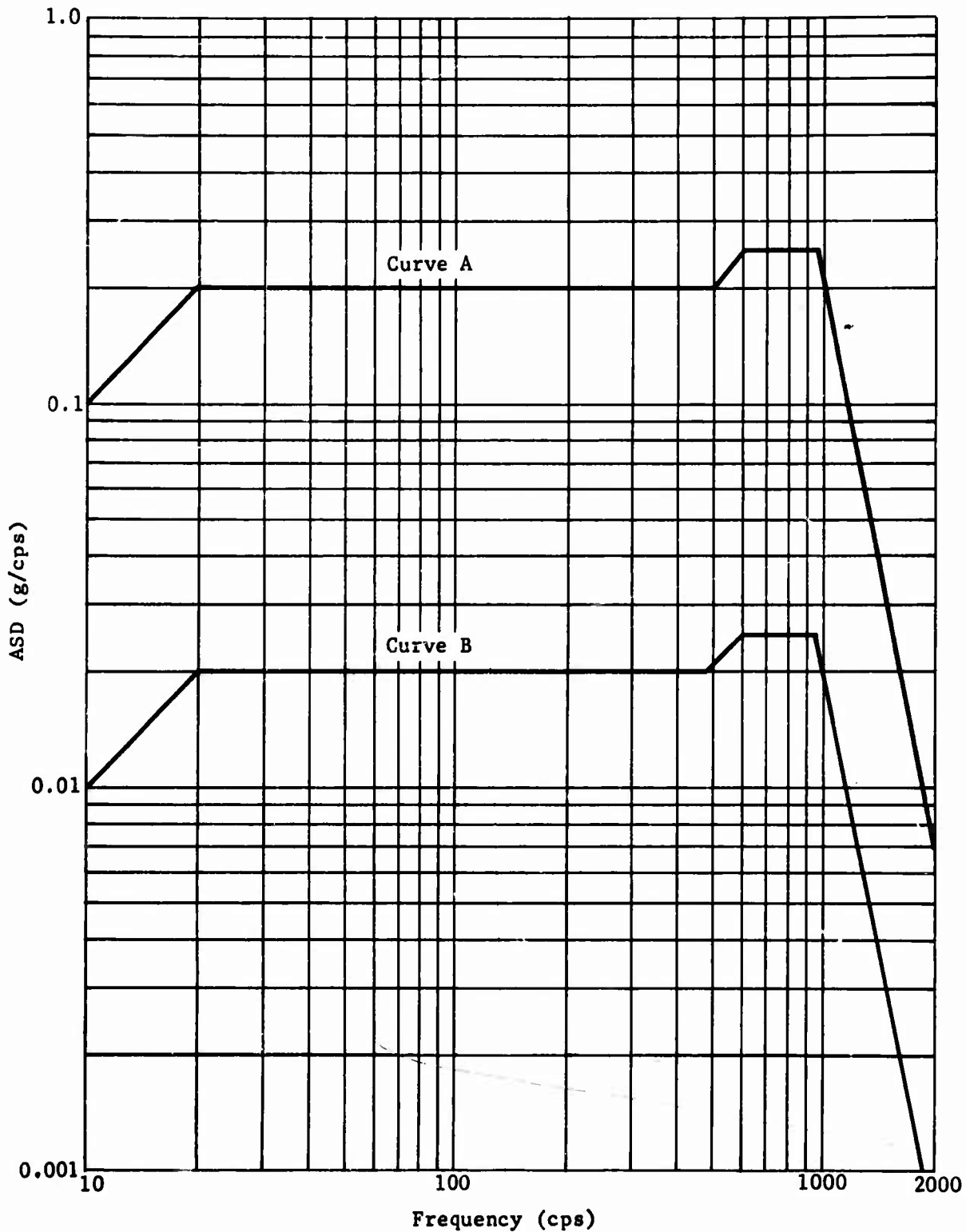

Fig. F-1 Acceleration Spectral Density (ASD)

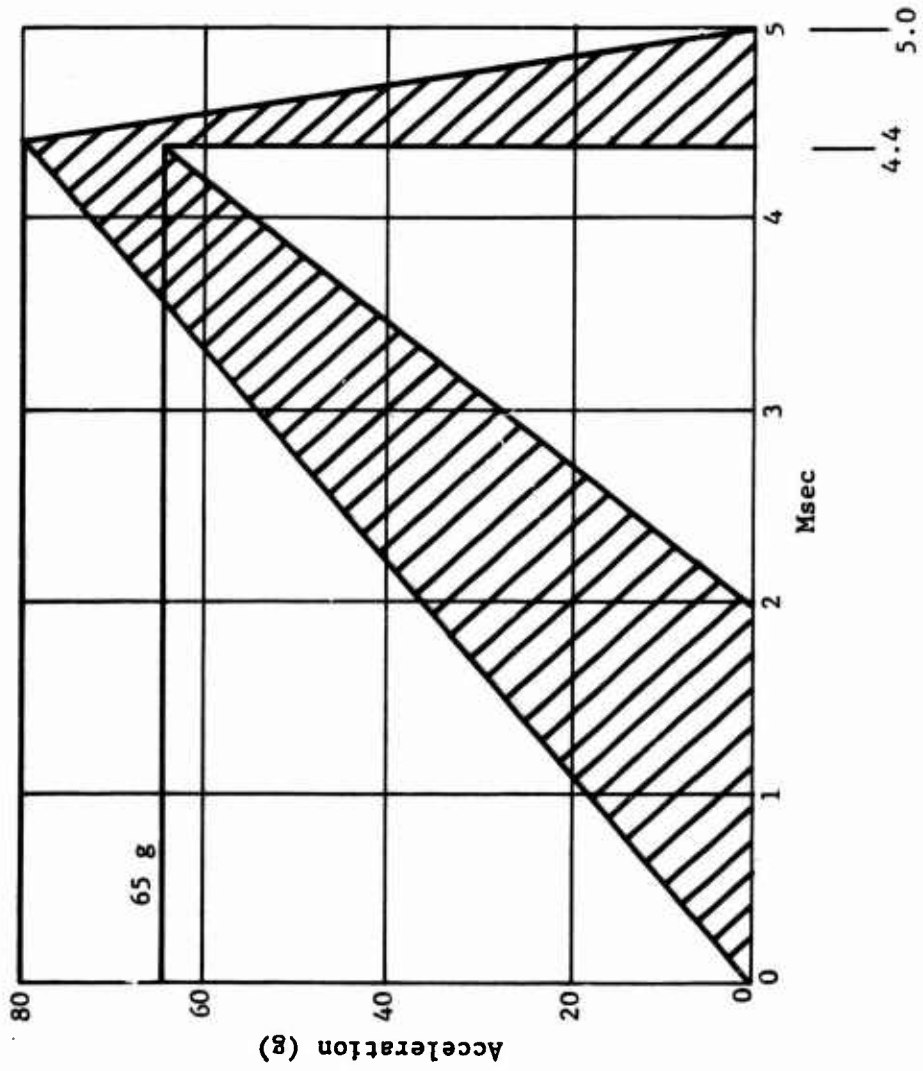

Fig. F-2 Shock Requirements

SSD-CR-64-32

G-1

APPENDIX G

SAMPLE RELIABILITY CALCULATIONS

Sample Calculation, Basic PIBOL*

Transtage Coast = 6 hr.

Transtage Powered Flight = 500 sec.

$$\begin{aligned}
 P_{\text{Booster}} &= P_1 P_2 P_3 - K_4 t_4 \lambda_4 - K_6 t_6 \lambda_6 - K_7 t_7 \lambda_7 \\
 &= (0.970)(0.980)(0.963) - (4.380 + 0.828 + 1.168 + 6.944 + \\
 &\quad + 18.000)(384 \times 10^{-6}) - (0.876 + 0.721 + 0.876 + 2.082 + \\
 &\quad + 9.000)(122 \times 10^{-6}) - (6.944 + 18)(1728 \times 10^{-6}) \\
 &= 0.915428 - (31.320)(384 \times 10^{-6}) - (13.555)(122 \times 10^{-6}) - \\
 &\quad - (24.944)(1728 \times 10^{-6}) \\
 &= 0.915428 - 0.012027 - 0.001654 - 0.043113
 \end{aligned}$$

$$P_{\text{Booster}} = 0.858434.$$

$$\begin{aligned}
 P_{\text{IGS}} &= 1 - K_5 t_5 \lambda_5 \\
 &= 1 - (0.876 + 0.721 + 0.876 + 2.082 + 9.000)(1300 \times 10^{-6}) \\
 &= 1 - (13.555)(1300 \times 10^{-6}) \\
 &= 1 - 0.017622
 \end{aligned}$$

$$P_{\text{IGS}} = 0.982378.$$

$$\begin{aligned}
 P_{\text{Switch}} &= 1 - K_9 t_9 \lambda_9 \\
 &= 1 - (4.380 + 0.828 + 1.168 + 6.944 + 18.000)(1.298 \times 10^{-6}) \\
 &= 1 - (31.320)(1.298 \times 10^{-6}) \\
 &= 1 - 0.000041
 \end{aligned}$$

$$P_{\text{Switch}} = 0.999959.$$

*Symbols defined in Chapter IIIC.

$$\begin{aligned}
 P_{\text{PIBOL}} &= 1 - K_8 t_8 \lambda_8 \\
 &= 1 - (4.380 + 0.828 + 1.168 + 6.944 + 18.000)(110.4 \times 10^{-6}) \\
 &= 1 - (31.320)(110.4 \times 10^{-6}) \\
 &= 1 - 0.003458
 \end{aligned}$$

$$P_{\text{PIBOL}} = 0.996542.$$

$$\begin{aligned}
 P_0 &= P_{\text{Booster}} [P_{\text{IGS}} P_{\text{Switch}} + P_{\text{PIBOL}} (1 - P_{\text{IGS}})] \\
 &= 0.858434 [(0.982378)(0.999959) + (0.996542)(0.017622)] \\
 &= 0.858434 [0.982337 + 0.017561] \\
 &= 0.858434 [0.999898]
 \end{aligned}$$

$$P_0 = 0.858346.$$

Sample Calculation, Broader PIBOL

Transtage Coast = 6 hr.

Transtage Powered Flight = 500 sec.

The calculations of P_{Booster} and P_{IGS} are identical to those contained in the sample calculation for Basic PIBOL:

$$P_{\text{Booster}} = 0.858434.$$

$$P_{\text{IGS}} = 0.982378.$$

The following calculations are unique to Broader PIBOL:

$$\begin{aligned}
 P_{\text{Switch}} &= 1 - K_9 t_9 \lambda_9 \\
 &= 1 - (4.380 + 0.828 + 1.168 + 6.944 + 18.000)(2.227 \times 10^{-6}) \\
 &= 1 - (31.320)(2.227 \times 10^{-6}) \\
 &= 1 - 0.000070
 \end{aligned}$$

$$P_{\text{Switch}} = 0.999930.$$

$$\begin{aligned} P_{\text{PIBOL}} &= 1 - K_8^t \lambda_8 \\ &= 1 - (4.380 + 0.828 + 1.168 + 6.944 + 18.000)(82.1 \times 10^{-6}) \\ &= 1 - (31.320)(82.1 \times 10^{-6}) \\ &= 1 - 0.002571 \end{aligned}$$

$$P_{\text{PIBOL}} = 0.997429.$$

$$\begin{aligned} P_0 &= P_{\text{Booster}} \left[P_{\text{IGS}} P_{\text{Switch}} + P_{\text{PIBOL}} (1 - P_{\text{IGS}}) \right] \\ &= 0.858434 [(0.982378)(0.999930) + (0.997429)(0.017622)] \\ &= 0.858434 [0.982308 + 0.017577] \\ &= 0.858434 [0.999885] \end{aligned}$$

$$P_0 = 0.858335.$$

SSD-CR-64-32

H-1

APPENDIX H

OTHER PIBOL MECHANIZATION CONCEPTS CONSIDERED

A. BASIC PIBOL MECHANIZATION WITH DISPLACEMENT GYROS

A block diagram of this Basic PIBOL configuration is shown in Fig. H-1. This PIBOL system consists of a displacement gyro/sequencer package and a signal transfer switch that are added in Stage III, a lateral acceleration sensing system added to Stage I compartment I-A, and modifications to the existing flight controls adapter-programmer.

The displacement gyro/sequencer package is a new package for PIBOL. The design of the gyro portion of the package and the packaging concept is based on the present Titan III rate gyro system design. A functional block diagram of the entire package, including sequencer, is shown in Fig. H-2. The sequencer portion of the package is identical to that described for the recommended Basic PIBOL system (Chap. III.B. of this report). During flight, the gyros will remain caged until the PIBOL mode is entered. At this time, the gyro outputs will replace the booster IGS attitude error outputs as the input to the control system displacement channels. After entering the PIBOL mode, the pilot's commands pass through circuitry that will adjust his control authority to that required during the various phases of flight. The pilot's commands are then connected to the gyro torquer and to the flight controls adapter-programmer.

Details of the sequencer operation and the signal transfer switch are explained in Chap. III.B. of this report.

Figure H-3 shows the 15 added resistors required to connect the signals from the gain change circuitry in the displacement gyro/sequencer package to the control system. These resistors are connected to existing circuitry within the adapter-programmer. All other circuitry within the adapter-programmer remains the same as for the automatic flight control system.

The lateral acceleration sensing system (PD96S0007) added to Stage I will be used to provide a display of lateral acceleration in the pilot's compartment. This package is identical to that presently being used in Stage II of Titan III.

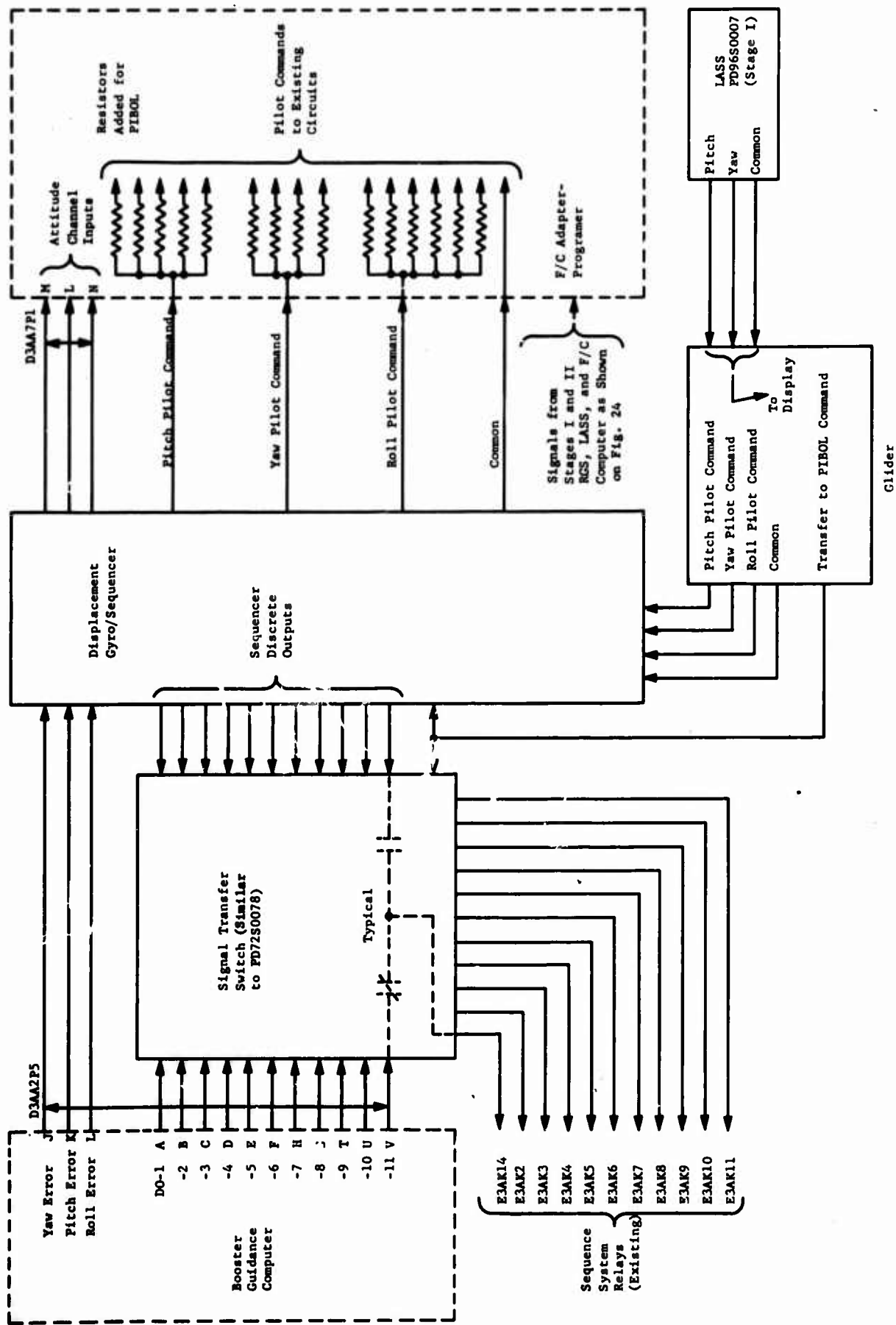

Fig. H-1 Basic PIBOL Configuration with Displacement Gyros

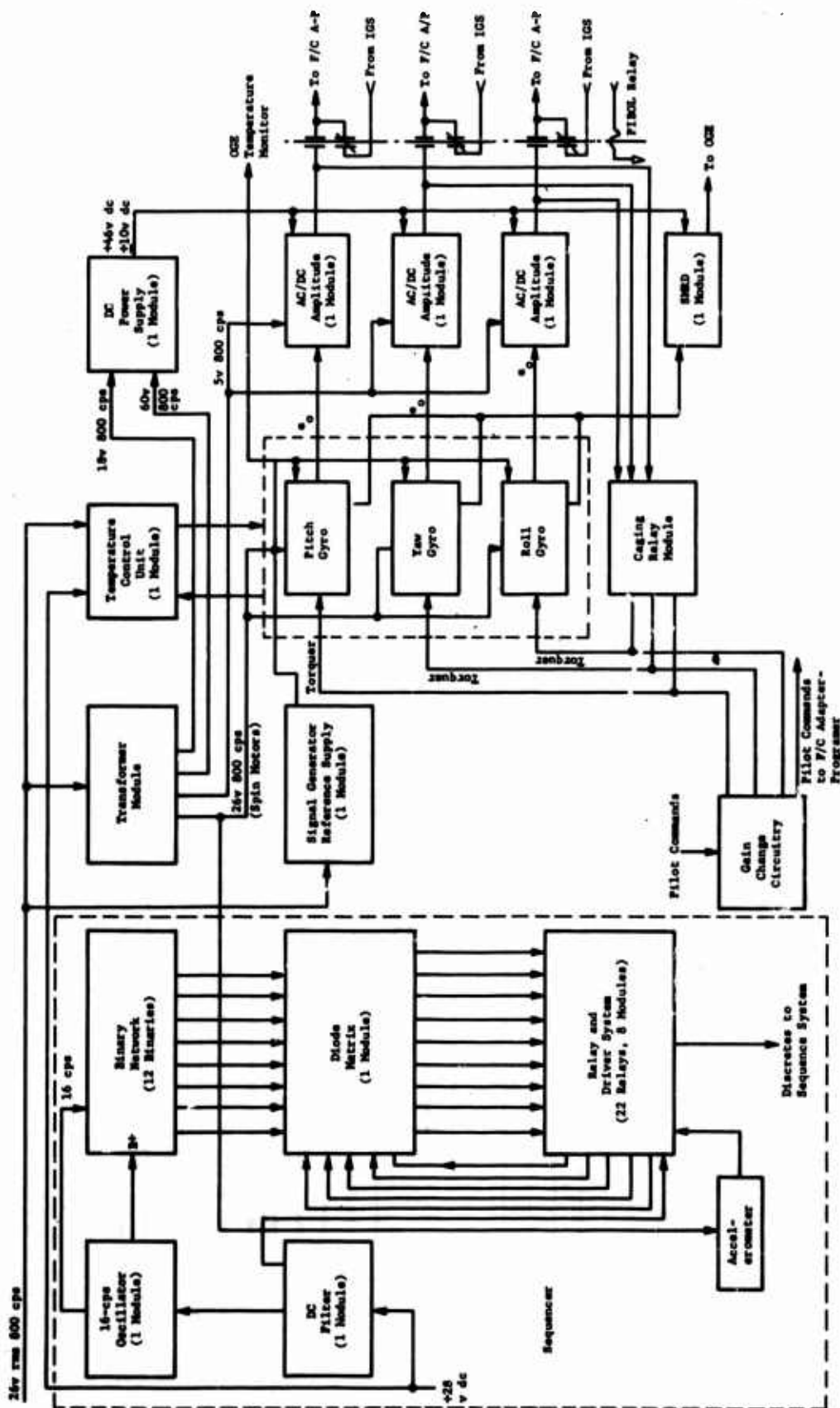

Fig. H-2 Displacement Gyro/Sequencer Package, Basic FIDOL

B. BROADER PIBOL MECHANIZATION CONCEPT

The mechanization concept for the Broader PIBOL concept, which does not meet performance requirements, is shown in the block diagram (Fig. H-3). The system requires addition of a roll rate gyro, a signal transfer switch, and the sequencer to Stage III, the addition of a lateral acceleration sensing system to Stage I, and modifications to the existing flight controls adapter-programmer.

To obtain the roll rate gyro without incurring development costs for a new package, a Titan III rate gyro system consisting of a pitch, yaw, and roll gyro is used, but only the roll channel will be connected.

The lateral acceleration sensing system (PD96S0007) will be used, as in the Basic system, to provide a display of lateral acceleration for the pilot.

The signal transfer switch and sequencer are identical to those proposed in the recommended basic system discussed in Chap. III.C.

The adapter-programmer changes for Broader PIBOL are shown in detail in Fig. H-4. The required modification of pitch and yaw rate channel gains during Stage 0 operation is accomplished by the addition of three resistors and four sets of relay contacts [noted as 101R1(P), 101R2(P), 101R3(P), 101K1(P), 101K2(P), 101K3(P), 000KP, etc on Fig. H-4] to the existing gain change circuitry in each rate channel. The required filter removal in the Stage I rate channels is accomplished by the addition of relays 101K7(P) and 105K7(P) in pitch and yaw, respectively. The gain modification in the accelerometer channels is accomplished by two resistors [103R1(P) and 107R1(P)], which are placed in the circuit by the action of relays 103K1(P) and 107K1(P). The Stage III roll rate gyro is connected during Stage III flight by relay 116K1(P) with resistor 116R1(P), providing the desired gain. The pilot's commands are inserted through the resistors 001R1(P) thru 001R5(P), 002R1(P) thru 002R4(P), and 003R1(P) thru 003R6(P) in pitch, yaw, and roll, respectively. These resistors connect the pilot's command to the various control channels, and provide the capability to adjust the system sensitivity (to his command) as required throughout the various phases of flight.

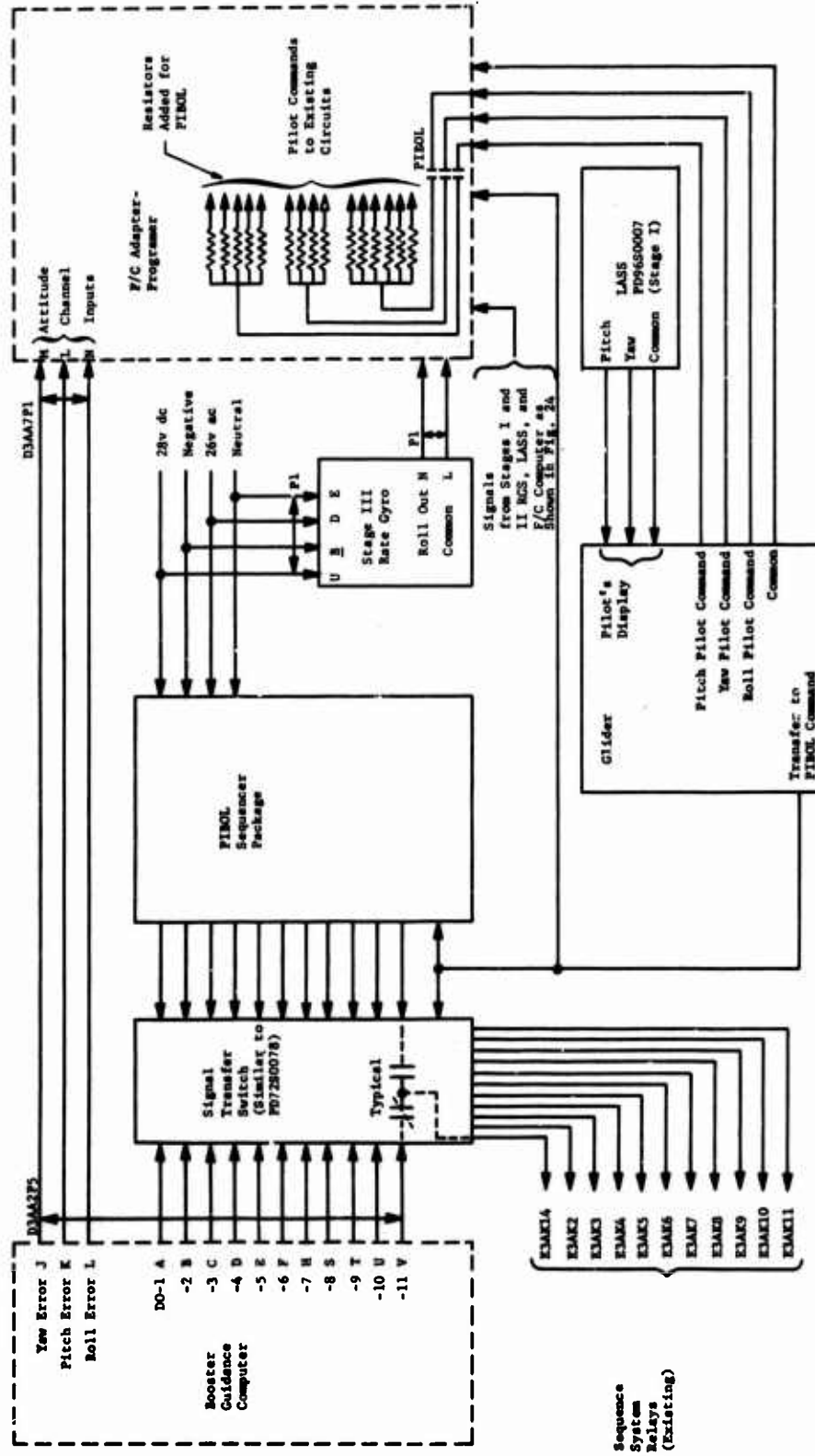

Fig. H-3 Broader FIBOL Configuration

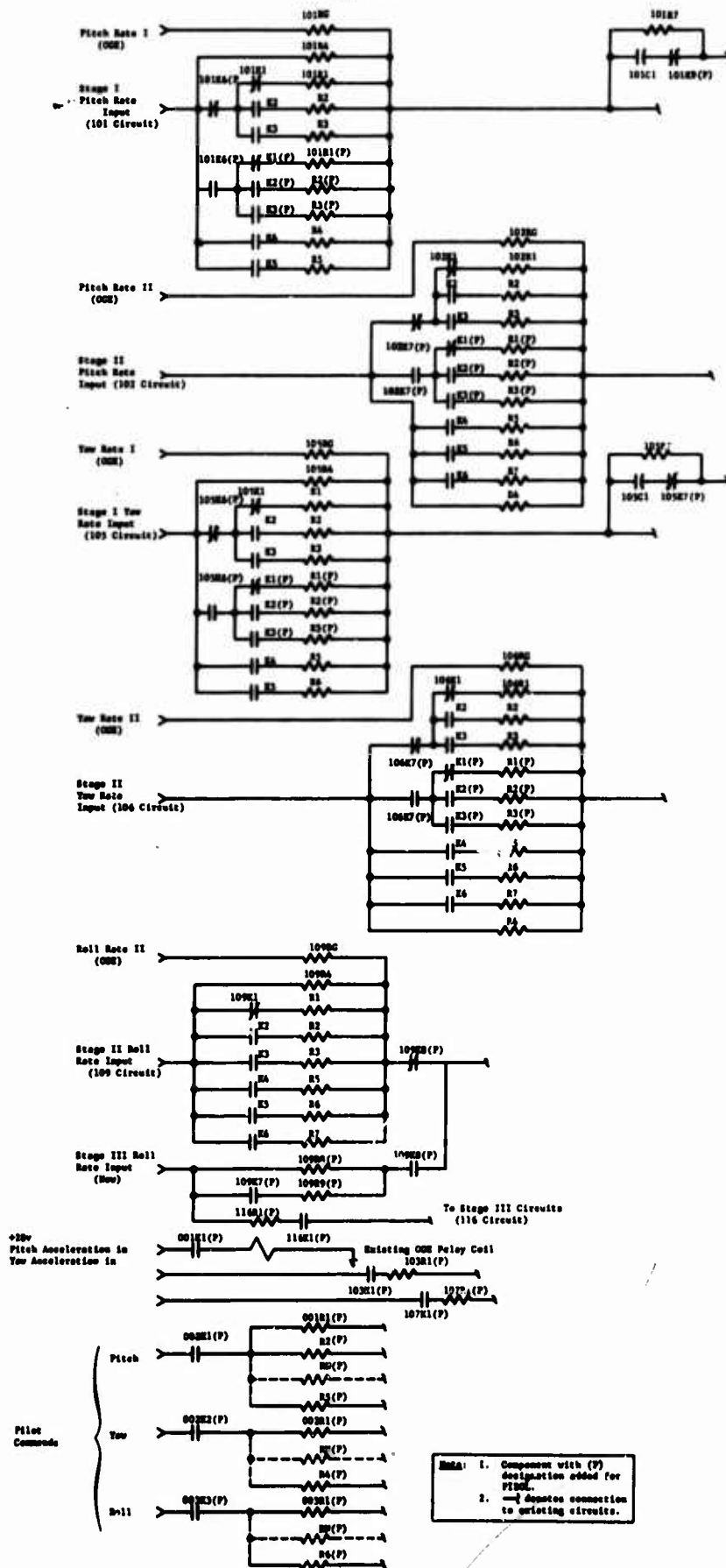

Fig. E-4 Broader FIDOL Adapter-Programmed Changes

APPENDIX I

FLIGHT CONTROL SYSTEM DEFINITION FOR PROGRAM 624A

Abstract - This appendix defines the characteristics of the Titan III flight control system as used for control system analytical studies at the Martin Company. System conventions, location of sensors, component characteristics, and a description of operation in each mode are provided so that a common basis may be used by all concerned, either for discussion or for analysis.

This appendix provides a current description of the Titan III flight control system as determined by and used in control system studies. System descriptions and numbers are those that most closely reflect the requirements of SSS-TIII-010 SLV Vehicle Model Specification and nominal values of vehicle and mission parameters affecting control system design.

Flight Control System Description - The Titan III flight control system provides stable control of the vehicle in all phases of flight in response to attitude command data issued by the inertial guidance system (IGS). To provide control without exceeding vehicle performance, load, or thrust vector control system requirements, it is necessary to use rate gyro and accelerometer feedbacks as described here. To stabilize the contributions of bending during Stage 0 and Stage I flight, two rate gyros are used, one in Stage I and one in Stage II. Signals from these two gyros are mixed in a manner to minimize the resulting signal due to bending. Control torques are obtained by angular displacement of the thrust vector during powered flight and by the on-off application or removal of small forces during coasting flight. Components are located as shown in Fig. I-1 and I-4.

Powered Flight Operation - Control during Stage 0 (if used), Stage I, and Stage II is obtained in basically the same manner. Referring to the block diagram (Fig. I-2), signals to the devices that control the thrust vector angular position (1₀, 2₀, 3₀, and 4₀ for Stage 0, hydraulic actuators 1₁, 2₁, 3₁, and 4₁ for Stage I, and hydraulic actuators 1₂, 2₂ and 3₂ for Stage II) are obtained as follows:

For Stage 0, the signal flow can be traced from the two rate gyros, IGS and accelerometers, through the gain and dynamic elements to the TVC output devices (1₀, 2₀, 3₀, and 4₀). Normally, the accelerometer channels are active only during the middle period of Stage 0 flight. The accelerometer channels provide the load-reduction feature through a combination of acceleration and velocity feedback. The channel configuration is as follows:

$$\frac{\text{Thrust Vector Deflection}}{\text{Lateral Acceleration}} = \left[K_A' + \frac{K_V \tau}{1 + \tau S} \right] \times \text{Filters,}$$

where

K_A' is the acceleration gain, K_V is the velocity gain, and τ is made large to approximate an integration. For consistency with hardware requirements, the bracketed term may be grouped as:

$$\begin{aligned} K_A' + \frac{K_V \tau}{1 + \tau S} &= (K_A' + K_V \tau) \left[\frac{1 + \frac{K_A' \tau}{K_A' + K_V \tau} S}{1 + \tau S} \right] \\ &= (K_{AZ \text{ or } Y}) \left[\frac{1 + \tau_2 S}{1 + \tau_1 S} \right]. \end{aligned}$$

The dynamics of the other channels are self-explanatory and are shown in Fig. I-2.

For Stage I flight, signal flow is identical to that during Stage 0, except that the accelerometers are not used and the Stage I actuators are the output devices.

Stage II flight is identical to Stage I flight, except that only one rate gyro is used and the Stage II actuators are the system output devices.

The control system for Stage III flight differs from that used during the other phases of flight in that no rate gyro system is used. For Stage III powered flight, the IGS attitude error signal in each channel is operated on a by lead-lag network to provide the effects of rate damping. These signals are then transmitted to the Stage III hydraulic actuators to position the thrust vector.

Coasting Flight Operation - For Stage III coasting flight, the control system operates in a manner that uses the fixed attitude control nozzles in an on-off mode to apply or remove control torques on the vehicle. Figure I-3 is the coast system block diagram.

Basically, two modes of operation of the coast control system occur:

- 1) The normal mode in which the eight attitude control system motors are turned on in a pulsing fashion to provide control;
- 2) A propellant settling mode in which the aft-pointing nozzles are all turned on to provide vehicle acceleration to force the Stage III propellants to the bottom of the tanks, so the Stage III main engines may be started. In this mode, the aft-pointed nozzles are selectively turned off to provide control torques.

In all of the modes of coast operation, the signal to the attitude nozzles is obtained from either of two parallel channels; either it is issued from a channel based on attitude error alone, or from one based on a combination of the attitude error and a signal derived from the attitude error. The latter channel is effective primarily when the vehicle angular rates are high and is as follows. The IGS attitude error signal is first passed through a lead-lag network. Since the attitude error signal is quantized, this produces a series of spikes impressed on a ramp function when the vehicle angular position is changing. Whenever this signal exceeds a given clipping level, the nozzle is turned on providing the required torque.

The channel operating on attitude error alone provides a single pulse of fixed duration whenever the attitude error exceeds either of two given levels. This channel provides control primarily after the initial high vehicle rates have been reduced.

Sequencing - The flight control system sequence operation is described in Chap. III.B.3.

Note: Effective location is that location used for flight control system analysis.

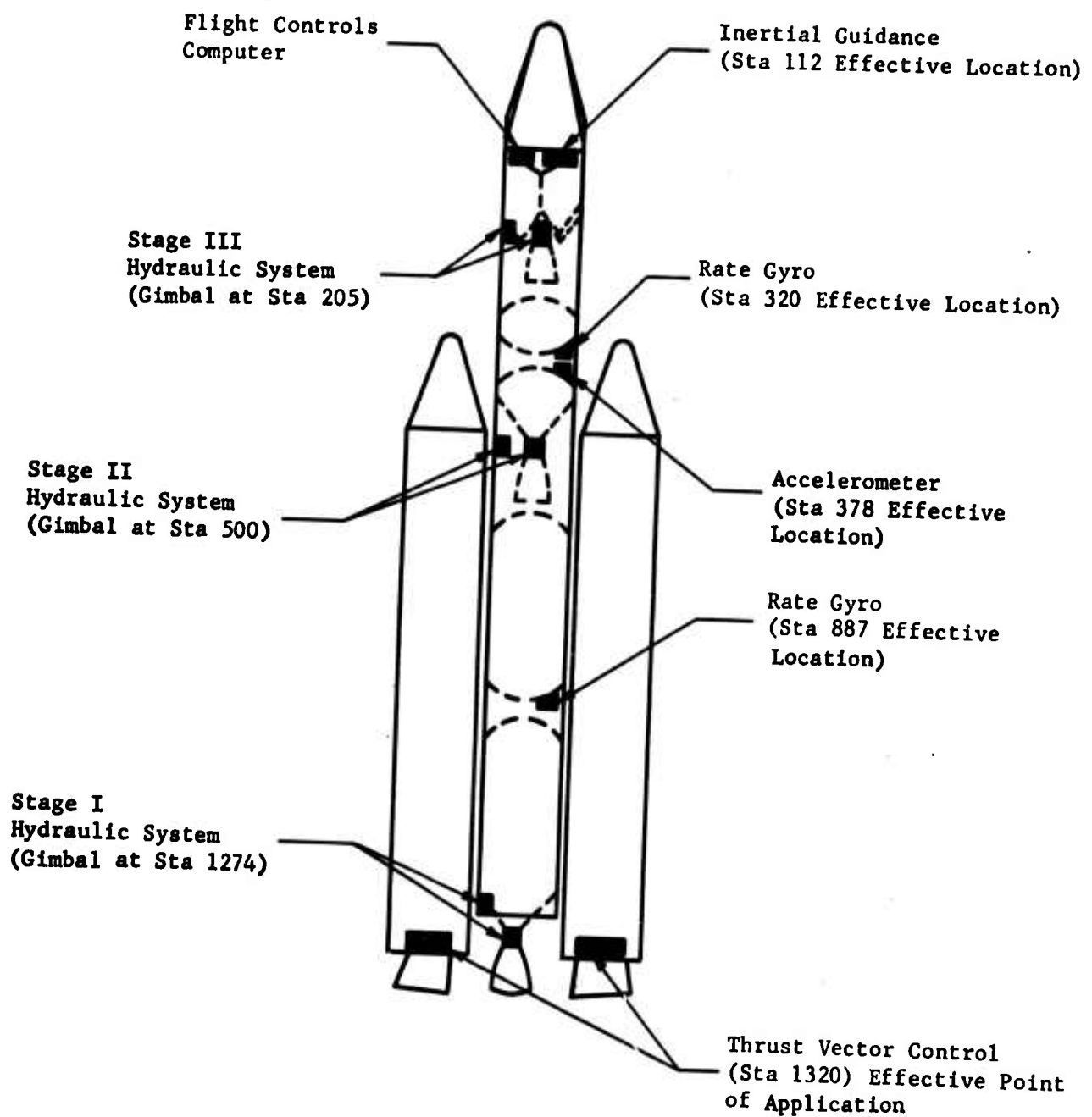
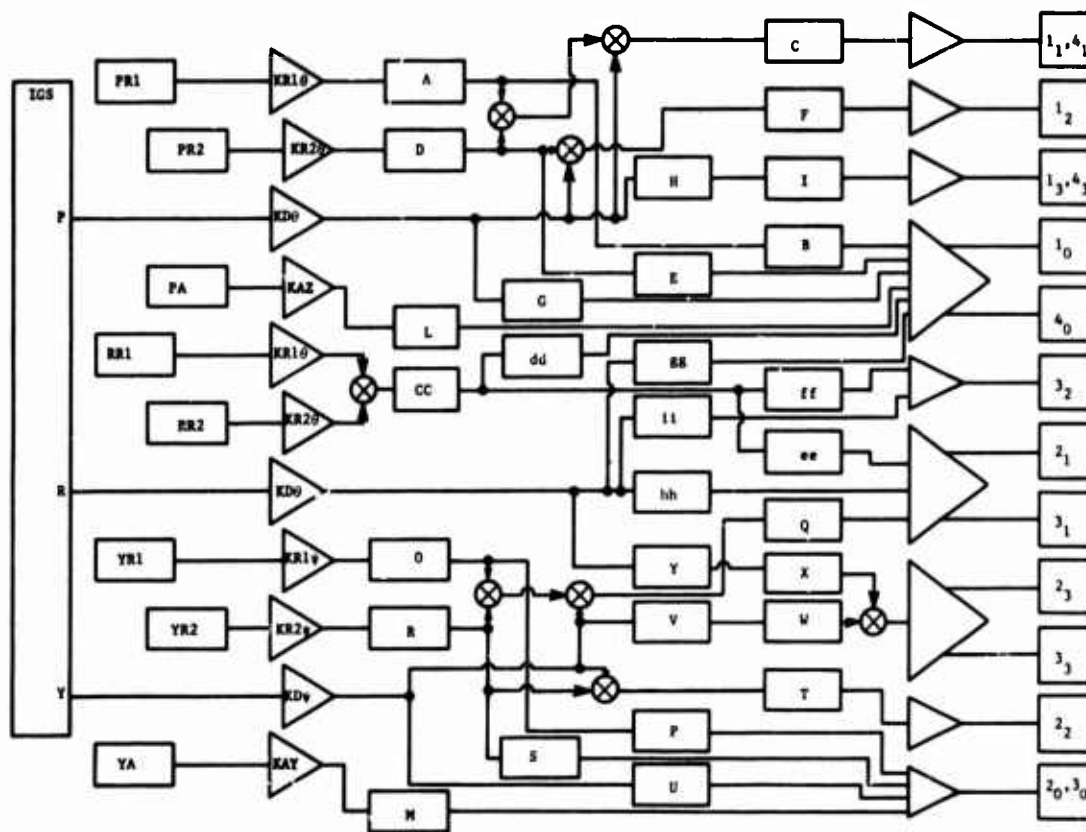

Fig. I-1 Flight Control System



Legend:

- PR1 Stage I Pitch Rate Gyro
- PR2 Stage II Pitch Rate Gyro
- RR1 Stage I Roll Rate Gyro
- RR2 Stage II Roll Rate Gyro
- YR1 Stage I Yaw Rate Gyro
- YR2 Stage II Yaw Rate Gyro
- P Pitch Attitude Error Signal (from IGS)
- Y Yaw Attitude Error Signal (from IGS)
- R Roll Attitude Error Signal (from IGS)
- PA Accelerometer in Pitch Channel
- YA Accelerometer in Yaw Channel

A, B, C, D, E,
 F, O, P, Q, R,
 S, T, cc, dd, ee,
 ff, gg, hh, ii,
 Dynamics of the form $\frac{1}{1 + S/\omega}$

G, U Dynamics of the form $\frac{1}{1 + \frac{2\zeta}{\omega} S + \frac{S^2}{\omega^2}}$ or $\frac{1}{1 + S/\omega}$
 ($\zeta > 1.06$)

H, V, Y Dynamics of the form $\frac{1 + S/\omega_1}{1 + S/\omega_2}$

I, W, X Dynamics of the form $\frac{1}{(1 + S/\omega)^2}$

L, M Dynamics of the form $\frac{1 + \tau_2 S}{(1 + \tau_1 S)(1 + S/\omega_1)(1 + S/\omega_2)^2}$

Fig. I-2 Powered Flight Control System

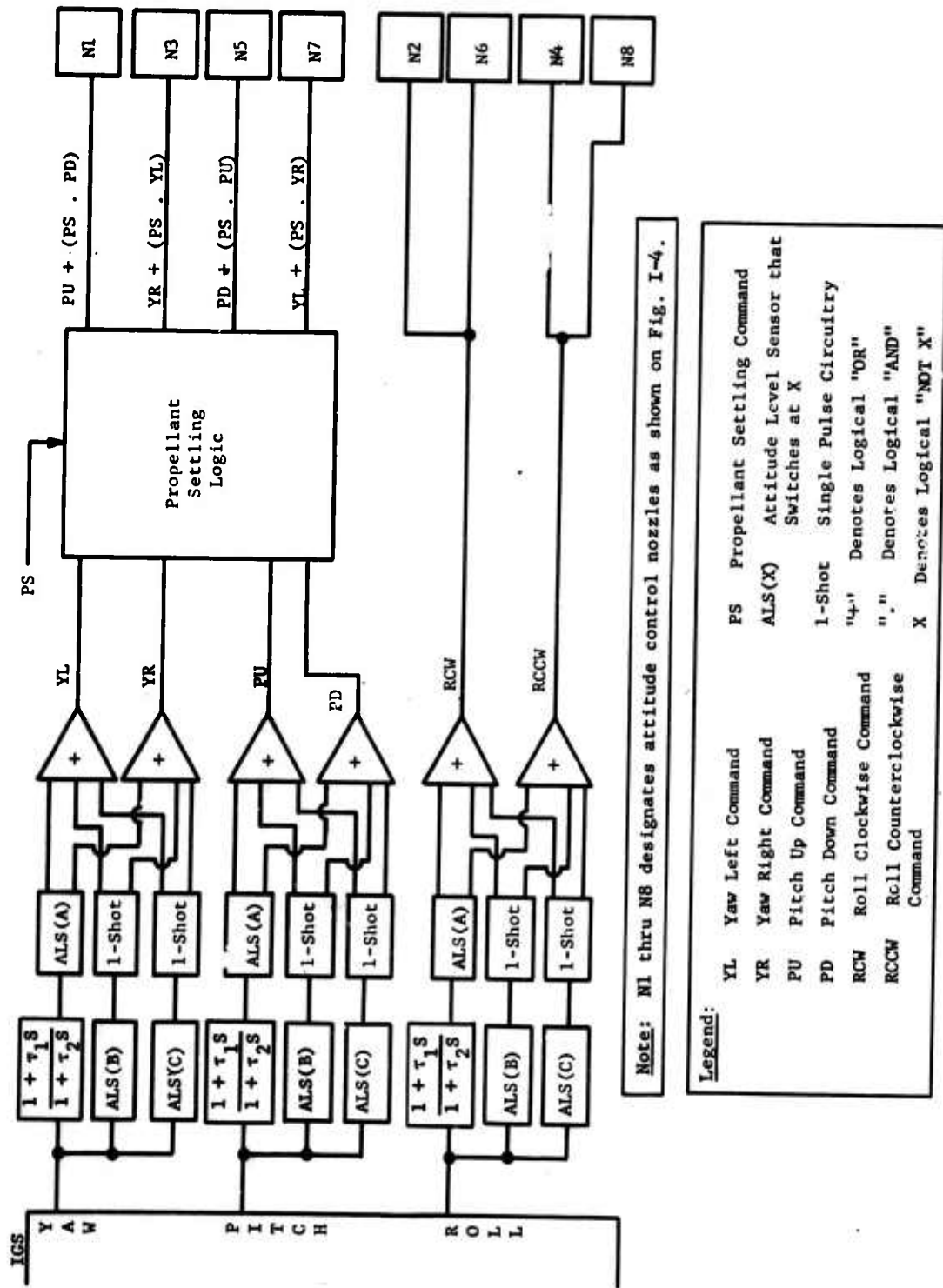

Note: N1 thru N8 designates attitude control nozzles as shown on Fig. I-4.

Legend:

YL	Yaw Left Command	PS	Propellant Settling Command
YR	Yaw Right Command	ALS(X)	Attitude Level Sensor that Switches at X
PU	Pitch Up Command	1-Shot	Single Pulse Circuitry
PD	Pitch Down Command	"+"	Denotes Logical "OR"
RCW	Roll Clockwise Command	"·"	Denotes Logical "AND"
RCCW	Roll Counterclockwise Command	X	Denotes Logical "NOT X"

Fig. I-3 Coast Control System

Note: 1. 1₀, 2₀, 3₀, and 4₀ refer to quadrants controlled by control system outputs 1₀, 2₀, 3₀, and 4₀.
 2. WLO is waterline zero or the target side of the vehicle.

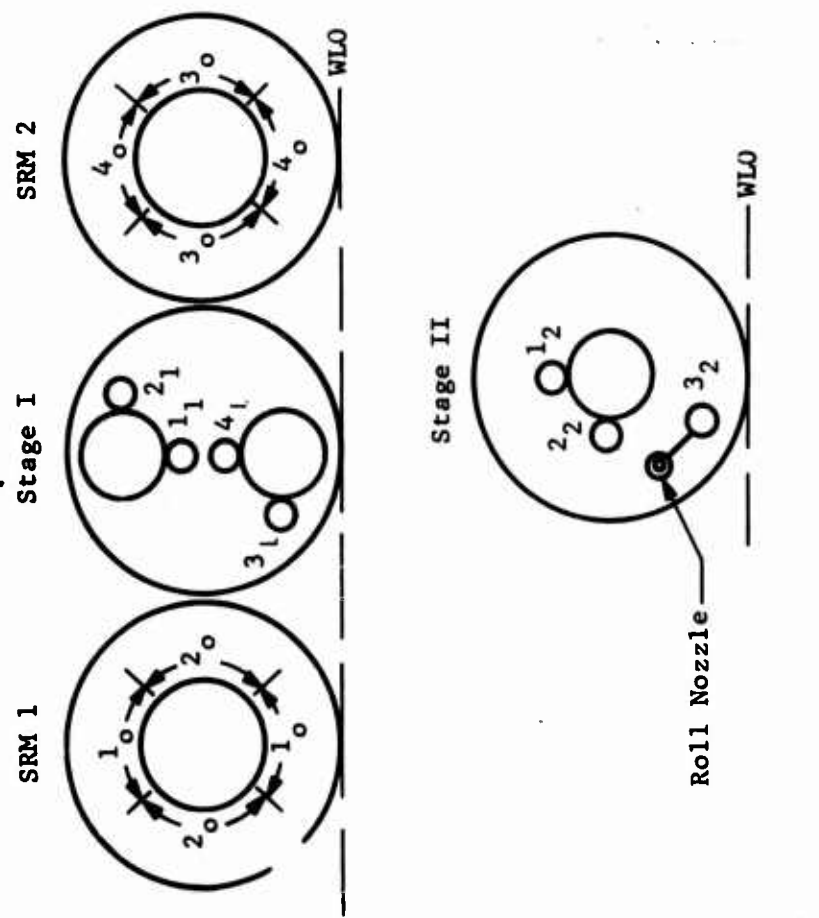
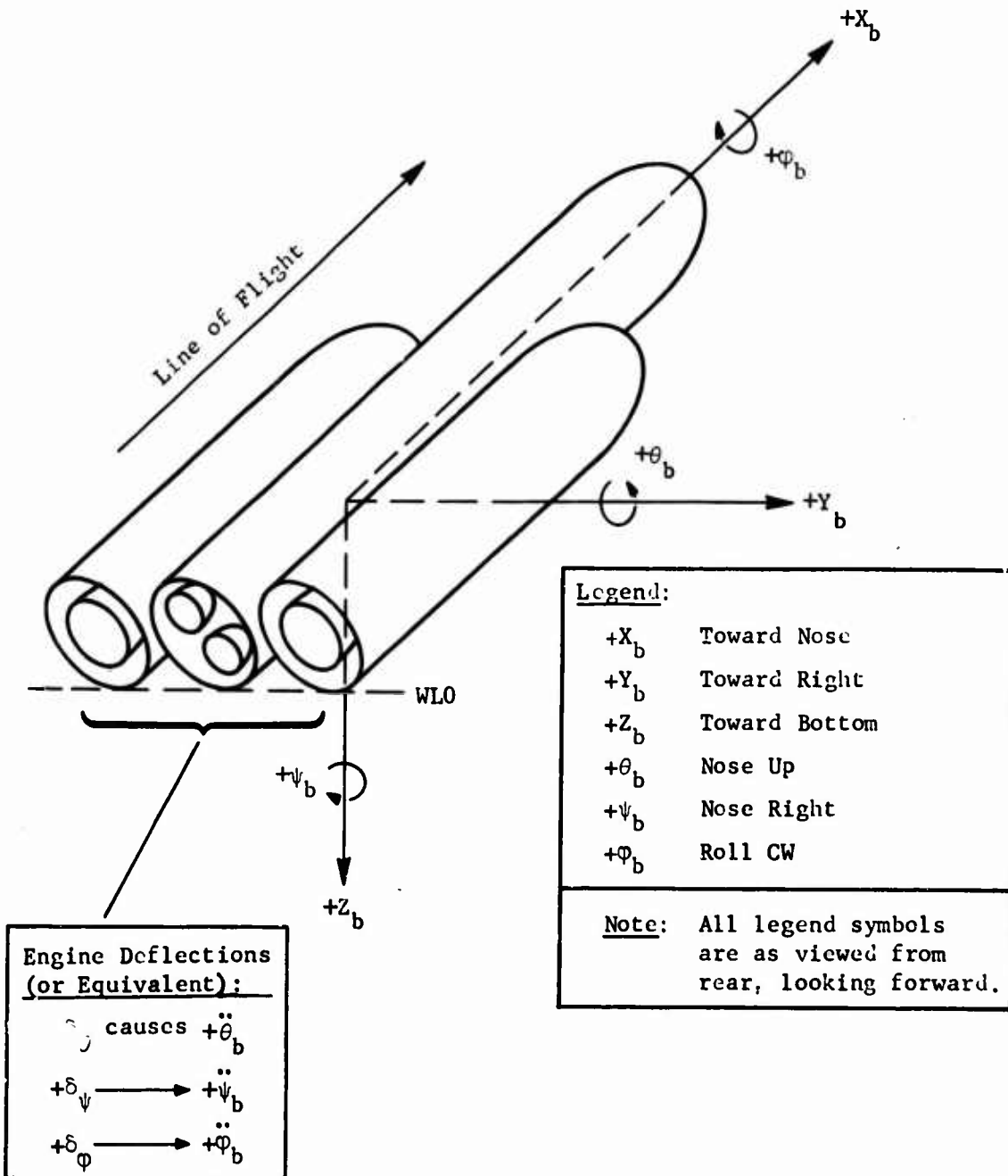

Fig. I-4: Engine-Actuator Nomenclature



Note: All legend symbols are as viewed from rear, looking forward.

The autopilot equations consistent with these sign conventions are:

$$\delta_{\theta} = -K_{D\theta}\dot{\theta}_b - K_{R1\theta}\ddot{\theta}_b - K_{R2\theta}\ddot{\theta}_b + K_{AZ}\ddot{Z}_b$$

$$\delta_{\psi} = -K_{D\psi}\dot{\psi}_b - K_{R1\psi}\ddot{\psi}_b - K_{R2\psi}\ddot{\psi}_b - K_{AY}\ddot{Y}_b$$

$$\delta_{\phi} = -K_{D\phi}\dot{\phi}_b - K_{R1\phi}\ddot{\phi}_b - K_{R2\phi}\ddot{\phi}_b$$

Fig. I-5 Autopilot Equations and Sign Conventions

Schematic Representations:

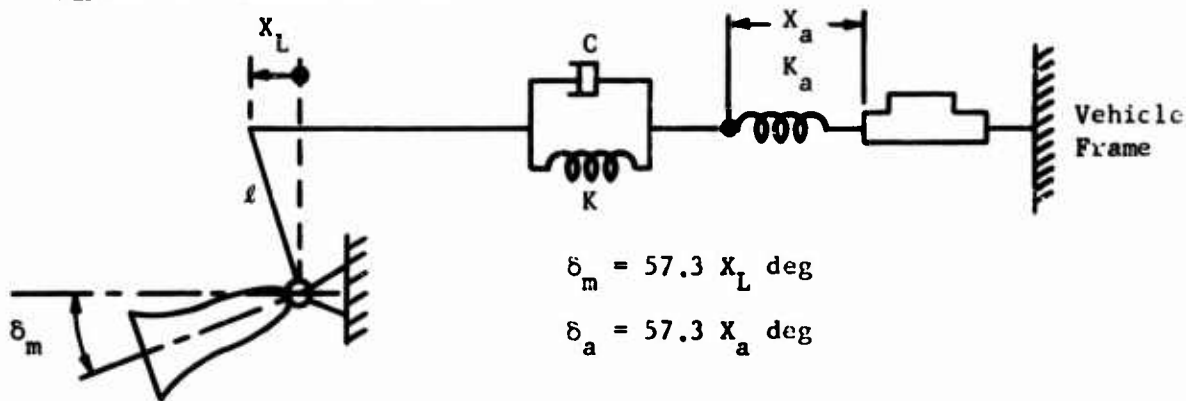

Block Diagram:

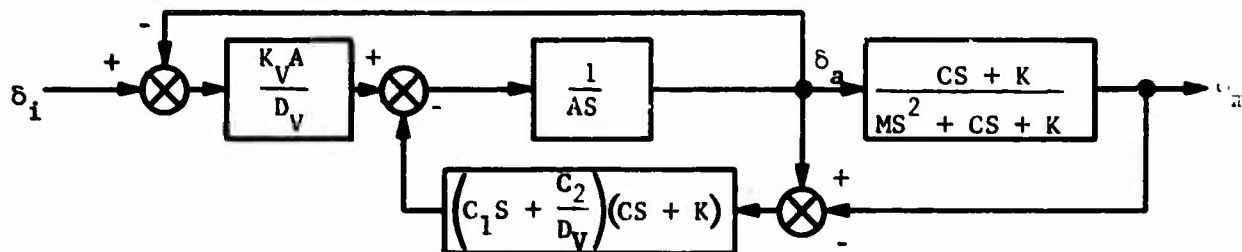

Legend:

<u>Symbol</u>	<u>Parameter</u>	<u>Units</u>	<u>Stage I</u>	<u>Stage II P&Y</u>
K_V	Velocity Constant	rad/sec	40	40
A	Piston Area	in. ²	4.68	2.55
D_V	Denominator of Valve Dynamics	--	(1+S/251.5)x (1+S/268)	Same as Stage I
C	Equivalent Damping Constant of Actuator Support	lb-sec/in.	14.9	22.06
K	Equivalent Spring Constant of Actuator Support	lb/in.	214,000	113,616
M	Effective Mass of Load	$\frac{\text{lb-sec}^2}{\text{in.}}$	10.04	42.9
C_1	Area/Oil Spring	$\frac{\text{in.}^3}{\text{lb}}$	0.355×10^{-5}	0.1213×10^{-5}
C_2	$\frac{1}{A} \frac{\partial Q}{\partial \Delta P}$	$\frac{\text{in.}^3}{\text{lb-sec}}$	0.132×10^{-2}	0.182×10^{-2}
l	Actuator Moment Arm	in.	14.33	10.04

Fig. I-6 Stage I Pitch-Yaw-Roll and Stage II Pitch Yaw Actuator Diagrams (Linear Representation)

Schematic Representation:

Same as Stage I P-Y-R and Stage II P-Y (Fig. I-6)

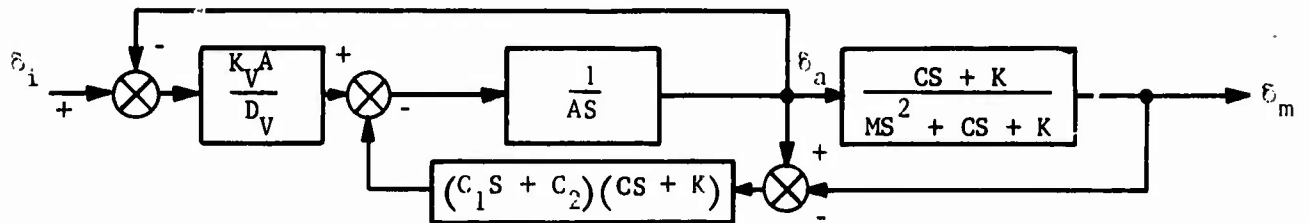
Block Diagram:Legend:

<u>Symbol</u>	<u>Parameter</u>	<u>Units</u>	<u>Stage II Roll</u>	<u>Stage III</u>
K_V	(See Fig. *-6 for Definition of Symbols)	rad/sec	25	30
A		in.^2	0.415	0.415
D_V			$(1 + s/628)^2$	$(1 + s/628)^2$
C		lb/sec/in.	1.056	2.65 (Pitch) 6.23 (Yaw-Roll)
K		lb/in.	50,000	16,000 (Pitch) 78,200 (Yaw-Roll)
M		$\frac{\text{lb-sec}^2}{\text{in.}}$	0.248	4.5
C_1		$\frac{\text{in.}^3}{\text{lb}}$	0.353×10^{-5}	0.271×10^{-5}
C_2		$\frac{\text{in.}^3}{\text{lb-sec}}$	0.519×10^{-3}	0.48×10^{-3}
l		in.	2.5	6.0

Fig. I-7 Stage II Roll Control and Stage III Pitch-Yaw-Roll Actuators Diagrams (Linear Representation)

Table I-1 Sensor Dynamic Characteristics (Linearized)

$$\text{Accelerometer: } \frac{E^*_{\text{out}}}{\text{Accelerometer Input}} = \frac{1}{1 + \frac{2(1.05)S}{326} + \frac{S^2}{326^2}}$$

$$\text{Rate Gyro: } \frac{E^*_{\text{out}}}{\text{Angular Rate Input}} = \frac{1}{(1 + 0.001465S) \left[1 + \frac{2(0.76)S}{147.5} + \frac{S^2}{147.5} \right]}$$

Thrust Vector Control System Dynamics (Stage 0):

$$\frac{\text{Thrust Vector Deflection}}{\text{System Input}} = \frac{K_{\text{TVC}}}{1 + 0.015S}$$

- *Note:**
1. Sensor scale factors (dc voltage gains) are lumped with the end-to-end gains specified and are not designated separately.
 2. K_{TVC} is the equivalent TVC gain in terms of degrees thrust vector deflection per degree command, normalized so that $K_{\text{TVC}} = 1$ at SRM start. For a nominal Titan III flight, K_{TVC} varies as follows:

Time of Flight	K_{TVC}
0 (Start)	1.0
30 sec	1.08
60 sec	1.12
80 sec	1.14
105 sec	1.155

Schematic Representation:

Same as Stage I P-Y-R and Stage II P-Y (Fig. I-6)

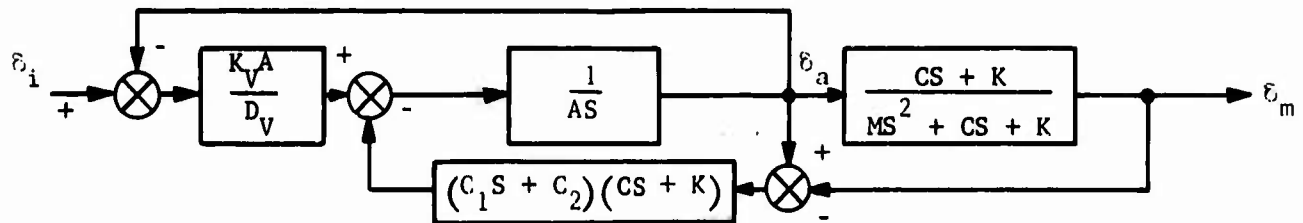
Block Diagram:Legend:

<u>Symbol</u>	<u>Parameter</u>	<u>Units</u>	<u>Stage II Roll</u>	<u>Stage III</u>
K_V	(See Fig. *-6 for Definition of Symbols)	rad/sec	25	30
A		in. ²	0.415	0.415
D_V			$(1 + s/628)^2$	$(1 + s/628)^2$
C		lb/sec/in.	1.056	2.65 (Pitch) 6.23 (Yaw-Roll)
K		lb/in.	50,000	16,000 (Pitch) 78,200 (Yaw-Roll)
M		$\frac{\text{lb-sec}^2}{\text{in.}}$	0.248	4.5
C_1		$\frac{\text{in.}^3}{\text{lb}}$	0.353×10^{-5}	0.271×10^{-5}
C_2		$\frac{\text{in.}^3}{\text{lb-sec}}$	0.519×10^{-3}	0.48×10^{-3}
l		in.	2.5	6.0

Fig. I-7 Stage II Roll Control and Stage III Pitch-Yaw-Roll Actuators Diagrams (Linear Representation)

Table I-1 Sensor Dynamic Characteristics (Linearized)

$$\text{Accelerometer: } \frac{E^*_{\text{out}}}{\text{Accelerometer Input}} = \frac{1}{\frac{1 + 2(1.05)S}{326} + \frac{S^2}{326^2}}$$

$$\text{Rate Gyro: } \frac{E^*_{\text{out}}}{\text{Angular Rate Input}} = \frac{1}{(1 + 0.001465S) \left[1 + \frac{2(0.76)S}{147.5} + \frac{S^2}{147.5} \right]}$$

Thrust Vector Control System Dynamics (Stage 0):

$$\frac{\text{Thrust Vector Deflection}}{\text{System Input}} = \frac{K_{\text{TVC}}}{1 + 0.015S}$$

- *Note: 1. Sensor scale factors (dc voltage gains) are lumped with the end-to-end gains specified and are not designated separately.
2. K_{TVC} is the equivalent TVC gain in terms of degrees thrust vector deflection per degree command, normalized so that $K_{\text{TVC}} = 1$ at SRM start. For a nominal Titan III flight, K_{TVC} varies as follows:

Time of Flight	K_{TVC}
0 (Start)	1.0
30 sec	1.08
60 sec	1.12
80 sec	1.14
105 sec	1.155

The block diagram of the flight control system is not presented because of the side variance in guidance equations from mission to mission. For design purposes, the following information is provided.

IGS Computer Ladder Output	0.1758 deg/quanta
Maximum Output	± 31 quanta (Roll)
	± 63 quanta (Pitch and Yaw)
Minor Computation Cycle Time	$\tau_1 = 0.05$ sec
Minor Cycle Time Delay	$\tau_2 = 0.015$ sec
Gimbal Angle Quantizer Sample Time	$\tau_3 = 0.010$ sec
Major Computation Cycle Time	$\tau_4 = 1.0$ sec
Major Cycle Time Delay	$\tau_5 = 0.750$ sec
Accelerometer Quantizer Sample Time	$\tau_6 = 0.000312$ sec

Linear Approximation for Minor Cycle Response:

$$\frac{\theta_E}{\theta_G} = \frac{1}{(1 + 0.0154 s) \left[1 + \frac{2(0.6)s}{65} + \frac{s^2}{65^2} \right]}$$

θ_E = quantizer output to autopilot displacement channel,

θ_G = effective vehicle attitude.

Table I-2 Control System Component Limits

Component	Type of Limit	Units	Limit
Stage 0 TVC Limits	Equivalent Position Limit, δ_a max	deg	T = 0, + 5.7 T = 26.3 sec, ± 6.1 T = 105 sec, ± 6.6
Stage I Actuator	Position Limit, δ_a max	deg	+ 4.9 (Includes 0.5 deg Snubbing at Each Extreme) (1)
	Rate Limit, $\dot{\delta}_a$ max	deg/sec	$29.5 \leq \dot{\delta}_a$ max ≤ 35
Stage II Pitch-Yaw Actuator	Position Limit, δ_a max	deg	± 2.71 (Includes 0.71 Snubbing at Each Extreme)
	Rate Limit, $\dot{\delta}_a$ max	deg/sec	$17.25 \leq \dot{\delta}_a$ max ≤ 35
Stage II Roll Actuator	Position Limit, δ_a max	deg	± 33 (Includes 4 Snubbing at Each Extreme)
	Rate Limit, $\dot{\delta}_a$ max	deg/sec	$148 \leq \dot{\delta}_a$ max ≤ 200
Stage III Actuator	Position Limit, δ_a max	deg	± 6 (Includes 0.73 Snubbing at Each Extreme)
	Rate Limit, $\dot{\delta}_a$ max	deg/sec	$23 \leq \dot{\delta}_a$ max ≤ 50
Lateral Accelerometers	Full-Scale Range	in./sec ²	± 1158 (2)
Rate Gyros	Full-Scale Range	deg/sec	± 20 (2)
IGS	Pitch and Yaw Full-Scale Range	deg	± 11.07
	Roll Full-Scale Range	deg	± 5.45
<p>Note: (1) Snubbing may be described as that portion of the actuator stroke in which actuator velocity is greatly restricted to absorb the kinetic energy of the engine as it moves into the stop.</p> <p>(2) These ranges are the ranges in which performance must meet specification requirements; outside of these ranges, performance is not guaranteed.</p>			

SSD-CR-64-32

J-1

APPENDIX J

STAGE 0 ROLL CONSIDERATIONS

The Stage 0 roll axis handling characteristic requirements were presented as limits on the roll-rate channel gains (as combined with the vehicle parameters thrust, roll-moment arm, and roll inertia). For all of Stage 0 flight, this requirement was

$$3 \leq \frac{K_R Tr}{I_{XX}} \leq 10,$$

where

$K_R = K_{R1} + K_{R2}$ Rate channel gain (sec),

$T =$ Thrust (lb),

$r =$ Roll moment arm (in.),

$I_{XX} =$ Roll moment of inertia (in.-lb-sec²).

Considering the nominal vehicle parameters for the 0 to 30 sec period of Stage 0 flight, this inequality can be expressed in terms of K_R only as

$$0.536 \leq K_R \leq 1.37.$$

In the flight control system initially designed for the standard Titan III/X-20A configuration, the roll rate gains were set at $K_{R2} = 0.25$, $K_{R1} = 0$, or $K_{R1} + K_{R2} = 0.25$, which is less than 50% of the rate gain required for PIBOL.

Figures J-1 and J-2 show that the response at the torsional mode frequencies resulting from this system depend primarily on the rate channel configuration. Figure J-1 shows that the first torsional mode peak, using only $K_{R2} = 0.25$, will be at an amplitude ratio of approximately 8 (equal to 18 db), phased at 70 deg. Figure J-2 shows that the second torsional mode under the same conditions will be at an amplitude ratio of 1.7 (4.6 db), phased at 21 deg. Further increase of K_{R2} to meet the PIBOL requirements is prohibited by considerations for the phase margin on the low frequency side of the first torsional mode.

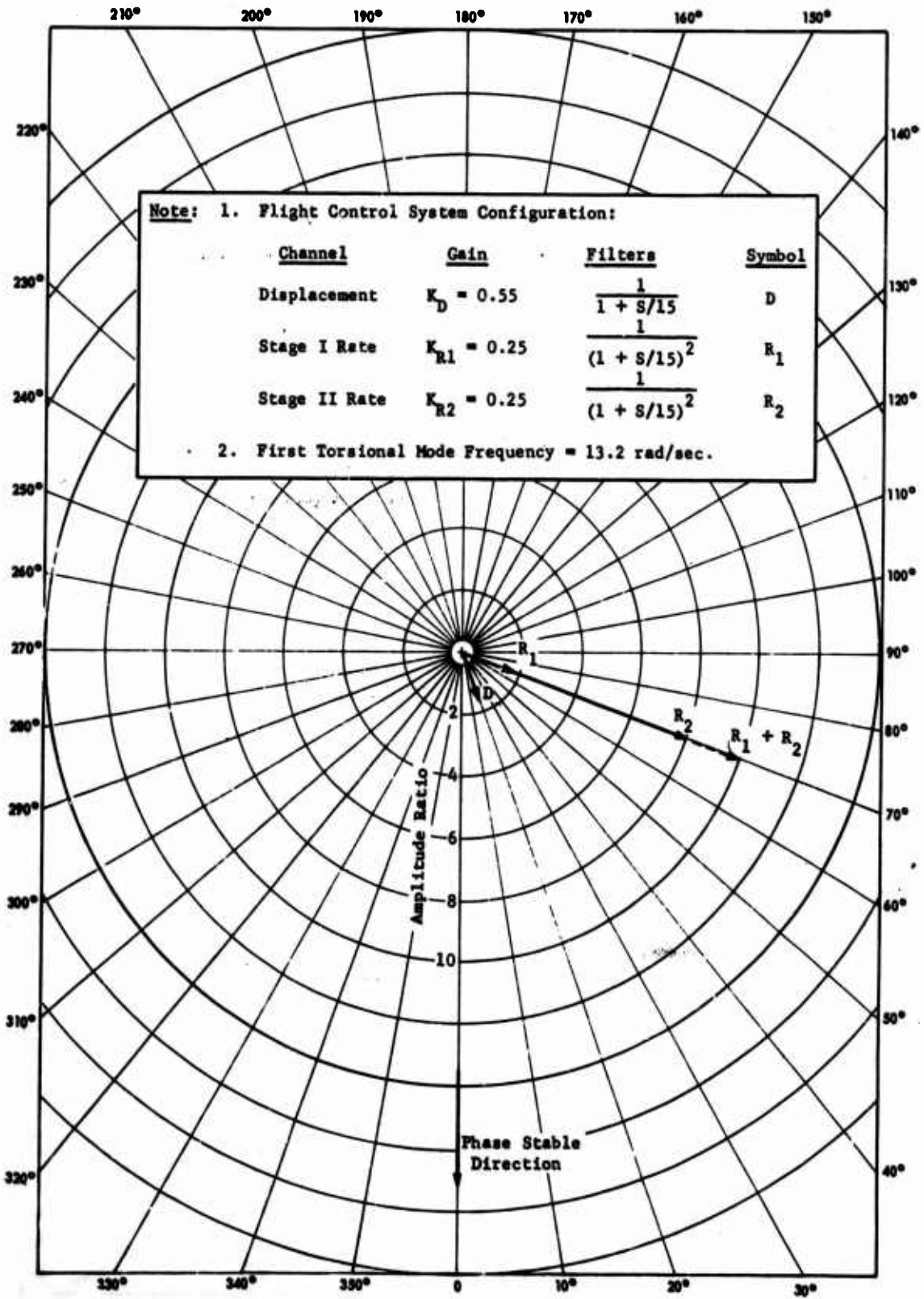

Fig. J-1 Vector Diagram, Stage 0 Roll Axis Response at First Torsional Mode Peak (at 0 sec)

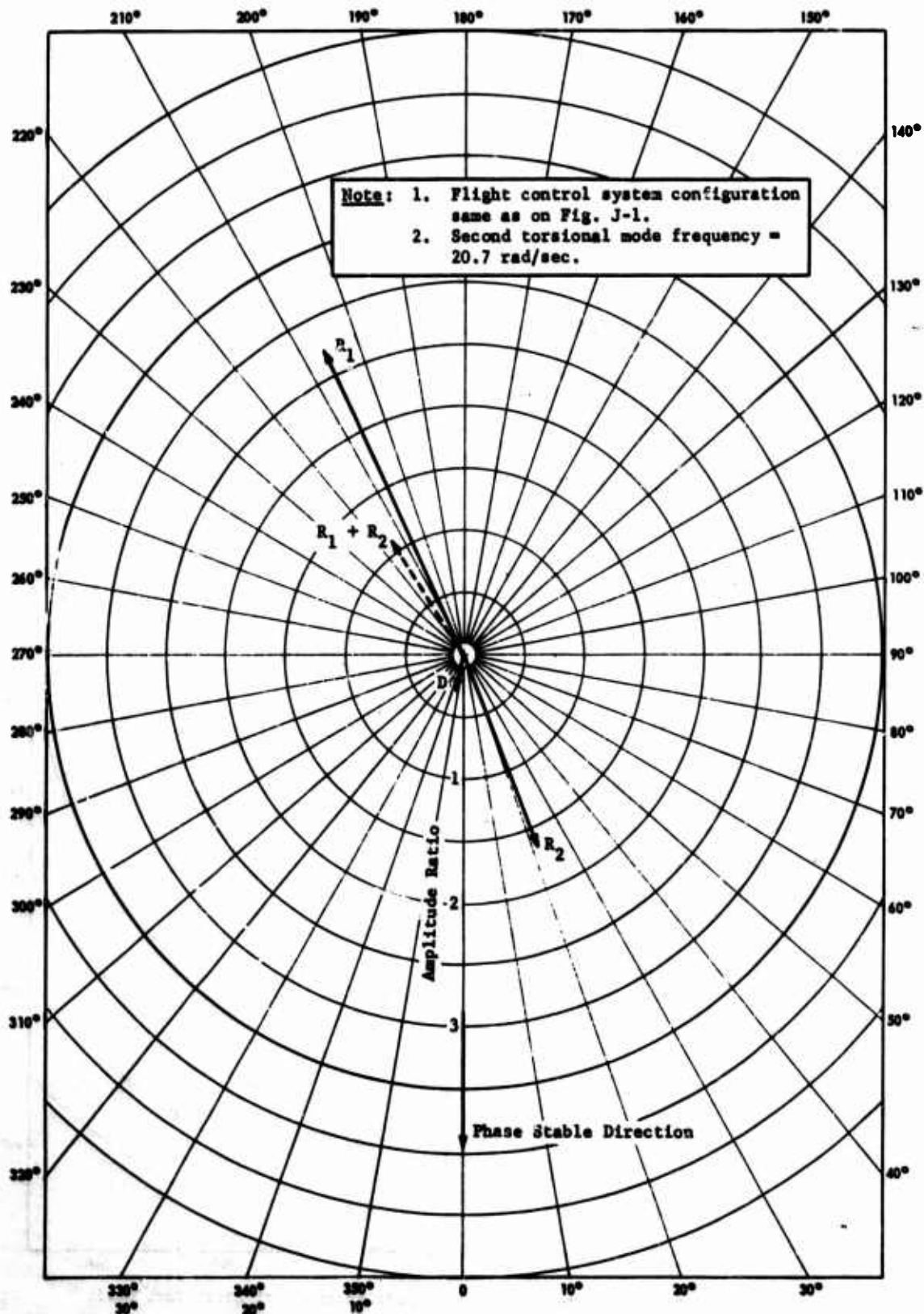

Fig. J-2 Vector Diagram, Stage 0 Roll Axis Response at Second Torsional Mode Peak (at 0 sec)

Use of the Stage I rate gyro, at the same gain; reduces the amplitude of the first torsional mode peak as shown on Fig. J-1, and, therefore, would allow an increase in rate channel gain. However, the response at the second torsional mode is unacceptable because of the phasing of the R1 vector (Fig. J-2).

Mixing of the two rate signals was also investigated as a means of allowing an overall increase in $K_{R1} + K_{R2}$. This also proved unacceptable, because it required an increase in the K_{R1} gain and a decrease in K_{R2} for first mode considerations, which resulted in the same general second mode response exhibited by use of K_{R1} only. The use of different filtering in the two rate channels also proved ineffective because of the large change in frequency of the first and second mode throughout flight.

The system proposed for Stage 0 provides a parallel rate channel with a relatively high low-frequency gain and heavy filtering, as shown in Fig. 21. The value of K_{R2}' (the parallel gain) was chosen to make $K_{R2} + K_{R2}'$ meet the PIBOL gain requirements. It is interesting to note that although this system meets the PIBOL roll gain requirements, the overall system response may not be that desired by the pilot. Some questions have been brought up concerning the bandwidth of the recommended PIBOL roll system.

Consider a simple model of the roll configuration, where the airframe is represented as a rigid body and aerodynamics are neglected. The system with only rate feedback can be described as shown in Fig. J-3.

The closed-loop transfer function of this system is

$$\frac{\phi}{\delta_c} = \frac{Tr / I_{XX}}{s + \frac{Tr}{I_{XX}} K_R(P)}$$

where

$K_R(P)$ is the rate gain required to meet the PIBOL requirements.

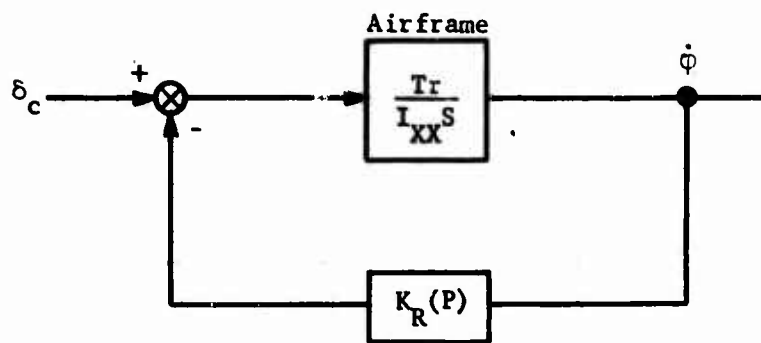

where

δ_c = Pilot command,

T = Thrust (lb),

r = Roll moment arm (in.),

I_{XX} = Roll moment of inertia (in.-lb-sec²),

S = Laplace operator,

$K_R(P)$ = Rate channel gain (sec),

$\dot{\phi}$ = Vehicle roll rate (rad/sec).

Fig. J-3 Simplified Block Diagram, Roll Control System

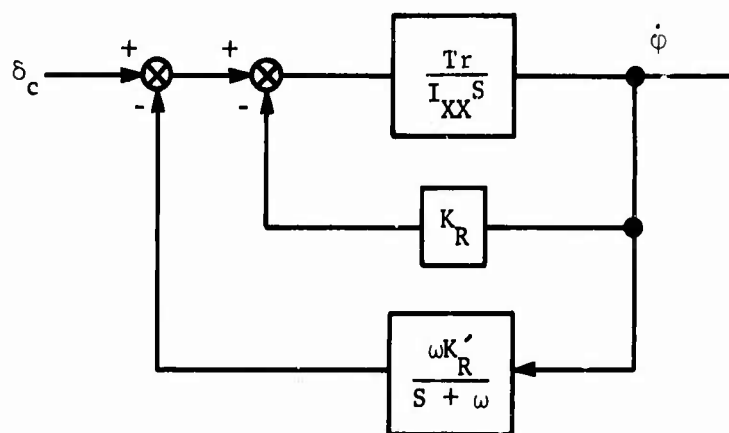

where

K'_R = Roll rate gain added for PIBOL (sec),

ω = Filter break frequency in channel
added for PIBOL (rad/sec),

K_R = Standard Titan III rate gain (sec).

Fig. J-4 Simplified Block Diagram, Stage 0 PIBOL Roll Control System

From the PIBOL roll requirements, it can be seen that the term that represents the system bandwidth, $\frac{Tr}{I_{XX}} K_R$, must be greater than 3, or in other words, the system bandwidth must be greater than 3 rad/sec.

The PIBOL Stage 0 roll system is shown in simplified form in Fig. J-4. The corresponding closed-loop transfer function is

$$\frac{\dot{\phi}}{\delta_c} = \frac{\frac{Tr}{I_{XX}} (S + \omega)}{S^2 + \left(\omega + \frac{Tr}{I_{XX}} K_R \right) S + \frac{Tr\omega}{I_{XX}} (K_R + K'_R)}$$

If we use the parameters that are proposed for PIBOL, the following identities apply,

$$K_R + K'_R = K_R(P),$$

$$\omega = 1 \text{ rad/sec.}$$

If we assume the transfer function, $\frac{\dot{\phi}}{\delta_c}$ has the form

$$\frac{\dot{\phi}}{\delta_c} = \frac{\frac{Tr}{I_{XX}} (S + \omega)}{S^2 + 2\zeta\omega_n S + \omega_n^2},$$

where

ζ = Damping ratio of the denominator (dimensionless)

ω_n = Natural frequency of denominator (rad/sec).

Then, the following also applies,

$$\omega_n = \sqrt{\frac{\text{Tr}\omega}{I_{XX}} (K_R + K'_R)} = \sqrt{\frac{\text{Tr}\omega}{I_{XX}} K_R(P)}$$

Therefore, if $\omega = 1$, and $K_R + K'_R = K_R(P)$ and meets the minimum

PIBOL requirement of $\frac{K_{RT}}{I_{XX}} \geq 3$, the natural frequency of the pro-

posed PIBOL system is $\omega_n = \sqrt{3} \approx 1.73$ rad/sec. The bandwidth of this system (considering the numerator term originating from the filter dynamics) is shown on Fig. J-5, and is almost identical to that of the system shown in the block diagram, Fig. J-3.

From this standpoint, the PIBOL system meets the bandpass requirements, but the final decision on acceptability still depends on further roll simulation studies.

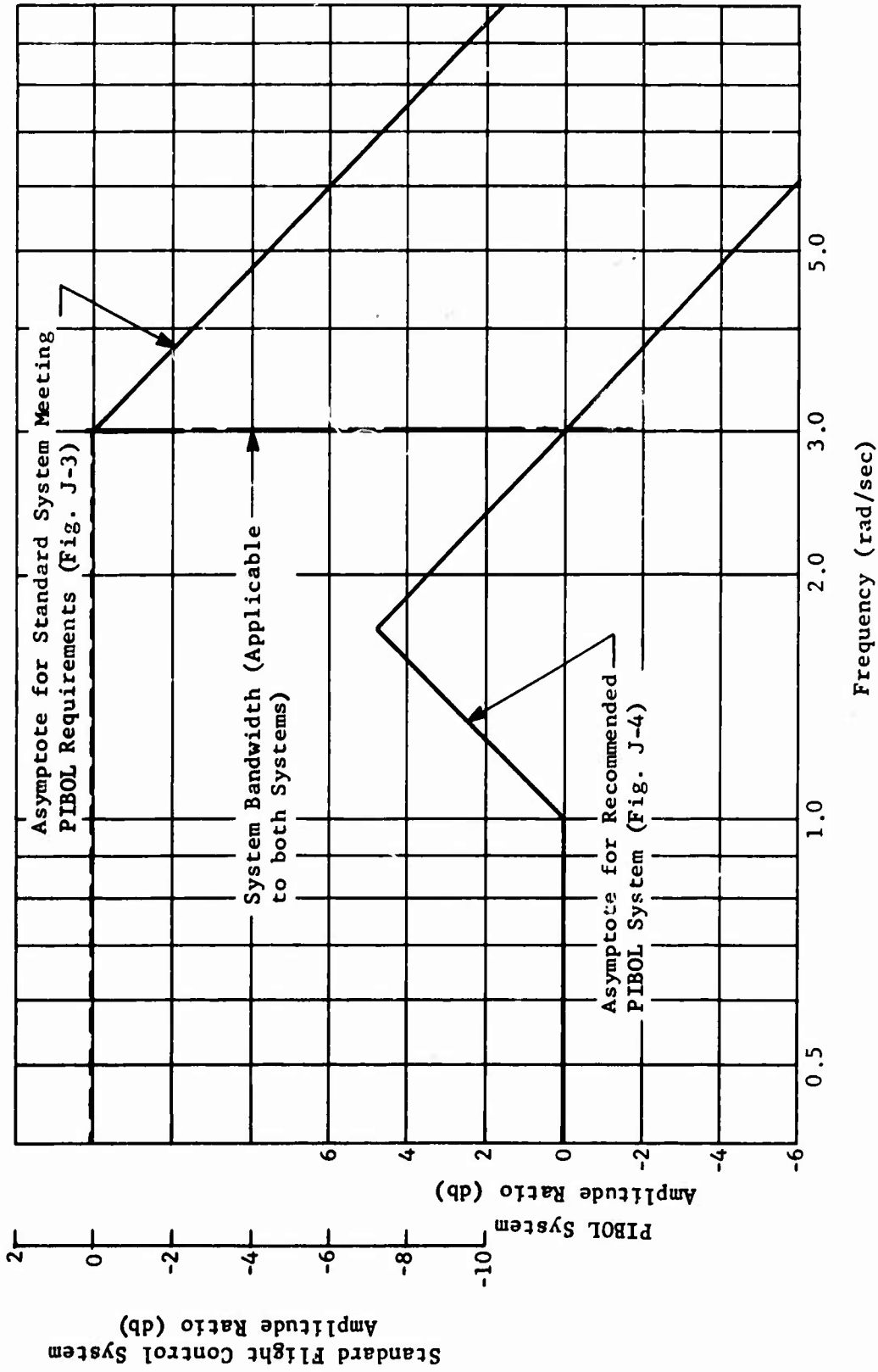

Fig. J-5 Comparison between Stage 0 PIBOL Roll Control System (Simplified) and Conventional Roll Control System (Simplified)