



Calhoun: The NPS Institutional Archive

Theses and Dissertations

Thesis and Dissertation Collection

1964

Proton magnetometer coherence

Anderson, Robert A.

Monterey, California: U.S. Naval Postgraduate School

<http://hdl.handle.net/10945/12923>



Calhoun is a project of the Dudley Knox Library at NPS, furthering the precepts and goals of open government and government transparency. All information contained herein has been approved for release by the NPS Public Affairs Officer.

Dudley Knox Library / Naval Postgraduate School
411 Dyer Road / 1 University Circle
Monterey, California USA 93943

<http://www.nps.edu/library>

NPS ARCHIVE
1964
ANDERSON, R.

PROTON MAGNETOMETER COHERENCE

ROBERT A. ANDERSON

DUDLEY KNOX LIBRARY
NAVAL POSTGRADUATE SCHOOL
MONTEREY, CA 93943-5101

LIBRARY
U.S. NAVAL POSTGRADUATE SCHOOL
MONTEREY, CALIFORNIA

PROTON MAGNETOMETER

CONFERENCE

* * * * *

Robert A. Anderson

PROTON MAGNETOMETER

COHERENCE

by

Robert A. Anderson

1

Submitted in partial fulfillment of
the requirements for the degree of

MASTER OF SCIENCE
IN
ENGINEERING ELECTRONICS

United States Naval Postgraduate School
Monterey, California

1 9 6 4

Library
U. S. Naval Postgraduate School
Monterey, California

PROTON MAGNETOMETER

COHERENCE

by

Robert A. Anderson

This work is accepted as fulfilling
the thesis requirements for the degree of

MASTER OF SCIENCE

IN

ENGINEERING ELECTRONICS

from the

United States Naval Postgraduate School

ABSTRACT

The results of coherence measurements of three free precession proton magnetometers are discussed. The measuring and data processing instrumentation is described. The noise associated with the instrumentation has been measured and presented in statistical form. The results of measurements with elementary local perturbations are included to illustrate the target detection problem. The limitations of the instrument for target detection are discussed and improvements suggested.

The writer wishes to express appreciation to Professor Carl E. Menneken for suggesting the problem, and Professor Harold A. Titus for encouragement and assistance in the preparation of this thesis.

TABLE OF CONTENTS

Section	Title	Page
1	Introduction	1
2	Instrumentation	3
3	Data Analysis	22
4	Results	29
5	Conclusions	47
	Bibliography	48
Appendix I	Results of Magnetic Field and Perturbation Experiments	
Appendix II	160 Programs and Operator Instructions	
Appendix III	Fortran Programs	
Appendix IV	Circuit Diagrams	

LIST OF ILLUSTRATIONS

Figure		Page
1	Basic Counter Unit	4
2	Effect of Noncoherent Gating	6
3	Counter Instrument	9
4	Magnetometer Input Section	10
5	Magnetometer Instrumentation	11
6	Data Aquisition and Processing	13
7	Storage Tape Format	15
8	Tape Deck Output Register	16
9	Interface Input Section	17
10	Output Section Decodeing and Resume	18
11	Preliminary Processing Setup	19
12	Perturbation Experiment Geometry	27
13 - 25	Graphical Results of Ideal Signal Experiment	30 - 42
26	Analog Plot H vs. Time	43
27	Analog Difference Plot	44
28	Proton Precession Signals	45
29	Filter Design	24

1. Introduction

The use of magnetometers for target detection requires identification of signals in the presence of the noise associated with the earth's magnetic field. The signal, in many cases, will be smaller in magnitude than the normal diurnal variation of the field, local fixed perturbations and geomagnetic pulsations. The system noise is of major concern in a detection scheme using magnetometers. This paper presents the preliminary results of a study of three proton free precession magnetometers operated under non laboratory conditions at Naval Postgraduate School La Mesa Village site.

The free precession magnetometer consists of a coil of wire in which a source of protons is placed. A strong field is applied to orientate the proton spins in a direction approximately normal to the earth's field. The polarizing field is then removed in a manner such that the spins cannot follow the field. The earth's field then causes the protons to precess about the lines of magnetic force at the Larmor frequency given by:

$$\omega = \gamma_p H$$

where γ_p = gyro magnetic ratio

$$= \text{magnetic moment/angular momentum} \quad (1)$$

and

$$H = \text{magnitude of external field}$$

(earth's field)

The net precessing magnetic moment causes a voltage to be induced in a coil surrounding the sample. Since the precessional frequency is dependent only on the external magnetic field, the measurement of H consists of measuring the frequency of the induced emf. The inherent

accuracy of the free precession magnetometer is determined by the spectral line width (ΔH), which is related to the relaxation time T_2 , and is given by:

$$\Delta H \approx \frac{1}{\gamma_p T_2} \quad (2)$$

where

$$= 3.6 \gamma$$

H \approx Half intensity width

$$T_2 \approx 1 \text{ sec (meas)}$$

$$\approx 10^{-5} \text{ GAUSS}$$

The gyromagnetic ratio has been measured by the NBS to better than 1 part in 10^5 . Full advantage of this inherent accuracy has not been utilized because of the problems associated with the frequency measurement. The frequency measurement is complicated by the fact that only a limited time is available for measurement. The signal received from the magnetometer is in the few microvolt range; hence locally generated electronic noise and transients from the polarizing operation cause the signal to noise ratio to be small. Standard counting techniques are used for measurement. To get the required accuracy, the frequency must be obtained from period or multiple period average measurements. The process is digital in nature and lends itself very nicely to computer processing of the data.

The main disadvantage is that any reasonable attempt to obtain an analog signal proportional to the measurement is an analog of period rather than frequency; therefore, the analog is the inverse of the quantity of interest. This does not present serious problems for target detection since the absolute magnitude of field is not of interest.

2. Instrumentation

2.1 Measurement

The engineering aspect of the measurement problem can be stated simply as follows:

Given: Three transient type signals of frequency approximately two kc/s occurring at the same time, with usable duration of about 3/4 sec. The signals are in the microvolt range. The recurrence rate is to be 2 sec. The measurements must be conducted in the presence of high electronic noise such as relay transients, contact noise and transients from the collapsing polarizing field.

Find: The frequency of the oscillations accurate to 1 part in 10^5 or better, and suitable means of data acquisition and processing.

The funds available excluded the possibility of using commercially constructed instruments or components. Also, modifications and interfacing would have to be done if components were used. Hence, the basic measuring instrumentation was constructed at NPGS. No detailed circuit design is presented; however the circuit diagrams are included in Appendix IV.

Assume the precession signal has been amplified in a suitable, low noise, narrow band preamplifier, and converted to a signal having fast waveform. Referring to the simplified block diagram of Fig. 1, the basic counter operation is as follows: Let the slow and fast counters consist of flip-flop counting units, connected to form a binary counter. The gate control flip-flop is capable of being triggered into either state. The multiplier converts the clock frequency to a harmonic of the precision 100 kc/s oscillator.

BASIC COUNTER UNIT

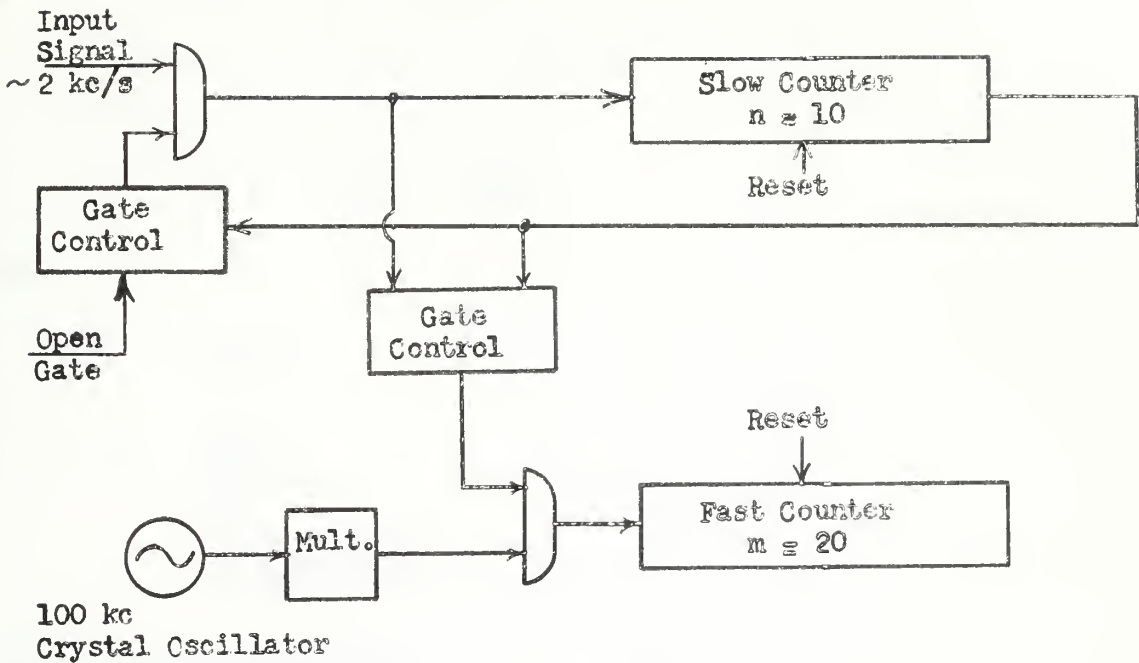

Figure 1

Let all counters be reset and ready for operation. The unknown input signal is applied to the gate. After a delay of approximately 150 ms, an external signal triggers the gate control to open the signal gate. The long delay is necessary to allow for damping the polarizing field and relay transients. The first pulse through the signal gate opens the clock gate. The fast counter then counts the number of clock pulses occurring during the time interval determined by the slow counter. The slow counter is increased one for each cycle of unknown input signal. After the slow counter has reached a predetermined number, both signal and clock gates are closed, and the number in the fast counter is a value of the time interval of 2^n cycles of unknown input signal, or can be reduced to the average period of the signal.

Let us define

N = number in fast counter

2^n = number of cycles of unknown signal

t_p = period of clock (μ sec.)

t_n = period of unknown signal

Then we have

$$\begin{aligned} T_m &= N t_p \\ t_m &= \frac{T_m}{2^m} \\ &= N t_p / 2^m \end{aligned}$$

Substituting in (1) gives

$$H = \frac{2\pi \cdot 2^m}{\gamma_p N t_p} \quad (3)$$

and with $n = 10$,

$$H = \frac{2348400 \times 1024}{N} \quad (4)$$

The accuracy of such a scheme depends on:

- a. The accuracy in determining the zero crossing of the unknown signal.
- b. Propagation delay in the slow counter.
- c. Gating speed.
- d. Accuracy of the clock.
- e. Plus or minus the las bit, due to noncoherent gating as illustrated in Fig. 2.

EFFECT OF NONCOHERENT GATING

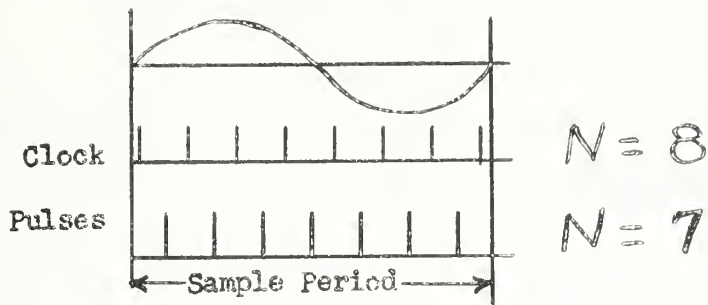

Figure 2

The errors due to determining the zero crossing are usually the dominant error in using this technique; however when averaged over 1024 cycles they become small and the largest error is the plus or minus last bit, as shown. The accuracy in determining the zero crossing in the presence of noise (2) is:

$$t_n = \frac{V_n}{S}$$

where:

t_n = maximum error in trigger time in sec.

V_n = peak to peak noise in volts.

S = slope of ideal signal at point of trigger level.

For a sinusoidal input:

$$S = \left. \frac{d}{dt} (V_s \sin \omega t) \right|_{\omega t = n\pi}$$

$$= V_s \omega$$

Assume a signal to noise ratio $2 V_s/V_n \approx 20$ db, and

$$\omega \approx 2\pi \times 2 \text{ KC/S}$$

then:

$$t_n = 0.318 \times 10^{-4}$$

For 1024 periods:

$$t_m \cong 0.3 \times 10^{-7} \text{ sec} \\ = 0.03 \mu \text{ sec}$$

The plus or minus last bit error if the clock is 100 kc, is ± 10 sec., and the other errors mentioned are negligible compared to the 10μ sec. error.

Consider the ± 1 bit limitation in detail for the earth's field 50950 γ , which is the approximate value at Monterey, California. let:

$$N = 00134051_8 \pm 1 \text{ bit}$$

$$1 \text{ bit} \cong 10 \mu \text{ sec.}$$

then:

$$\Delta H = \pm 1.1 \gamma$$

This becomes the sensitivity of the instrument. If the clock is increased to 1 mc/sec, 1 bit $\cong \mu$ sec., and:

$\Delta H = \pm 0.11 \gamma$; however other noise becomes appreciable and cannot be neglected. The circuits were designed for 1 mc/sec operation, but the measurements to date were conducted at 100 kc/s and 300 kc/s clock rates. The added complication is to construct 3 meters that will read identical, the input circuitry and slow counters must have identical characteristics. This is impossible from a practical point of view. The result is that the three counters with an ideal signal input can vary ± 1 bit in comparing their readings.

A simplified block diagram and photo of the magnetometer is shown in Figs. 3, 4 and 5. It must be remembered that operation

is to be in remote locations where extremes of temperature, line voltage fluctuations, poor grounds, etc. will be found; hence circuits that are sensitive to these variations must be carefully compensated.

For the experiments under consideration, locating the sensing coils approximately 500' apart would be sufficient; however for further experiments a distance of greater than 500' might be necessary. Therefore, a provision to place the preamps in the line nearer the sensing coils for improved signal to noise ratio was included. Bias for the preamps is applied to the signal line, from the console to eliminate the need for battery replacement. The relays that provide the two to three amps of polarizing current, and provide for dissipation of the stored energy when polarizing current is turned off, must precede the preamp. Since this unit is placed near the sense coil, it must be magnetically clean.

Referring to the block diagram the components that are common to the three units are the clock, timer, recorders and the power supplies.

COUNTER INSTRUMENT

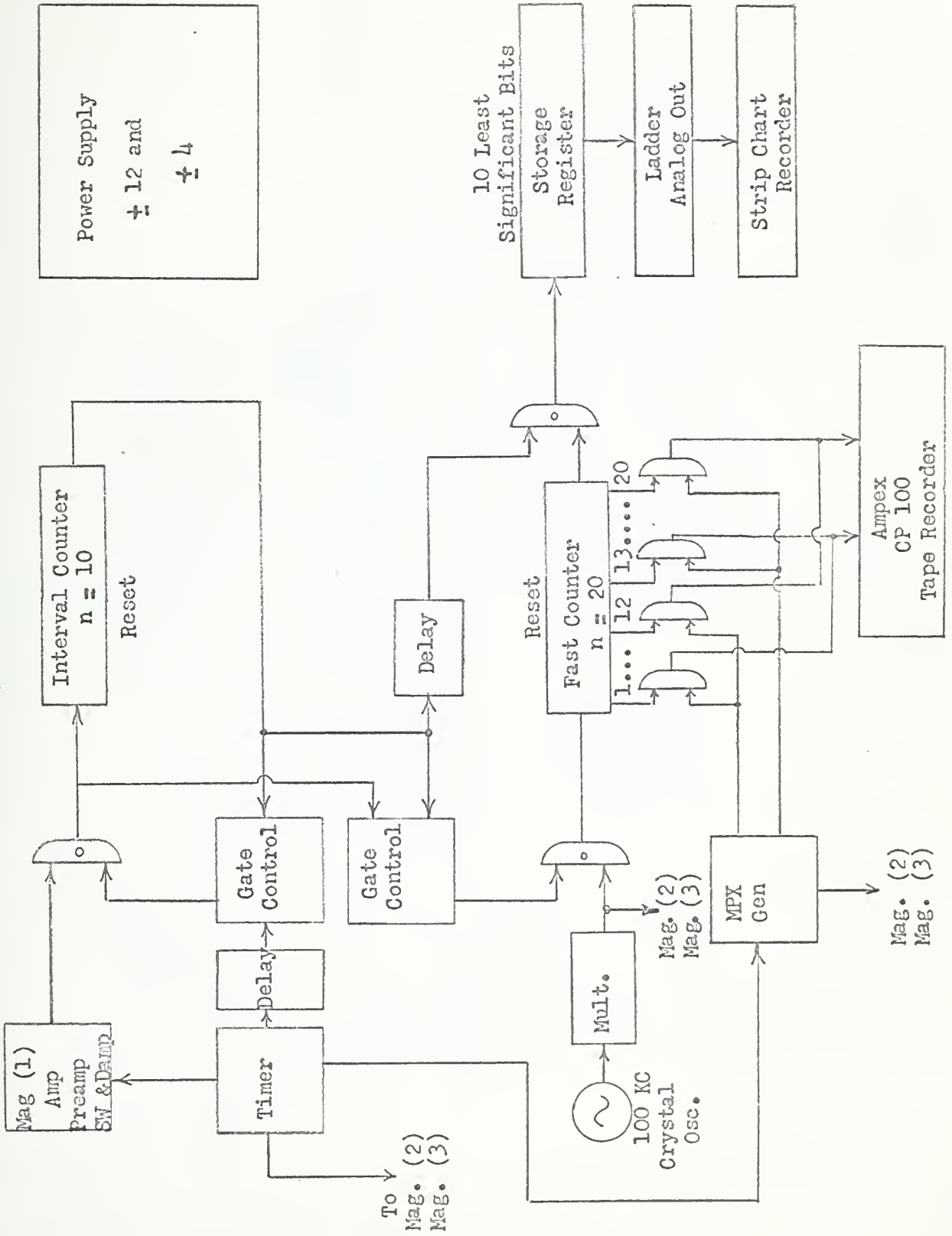

Figure 3

MAGNETOMETER INPUT SECTION

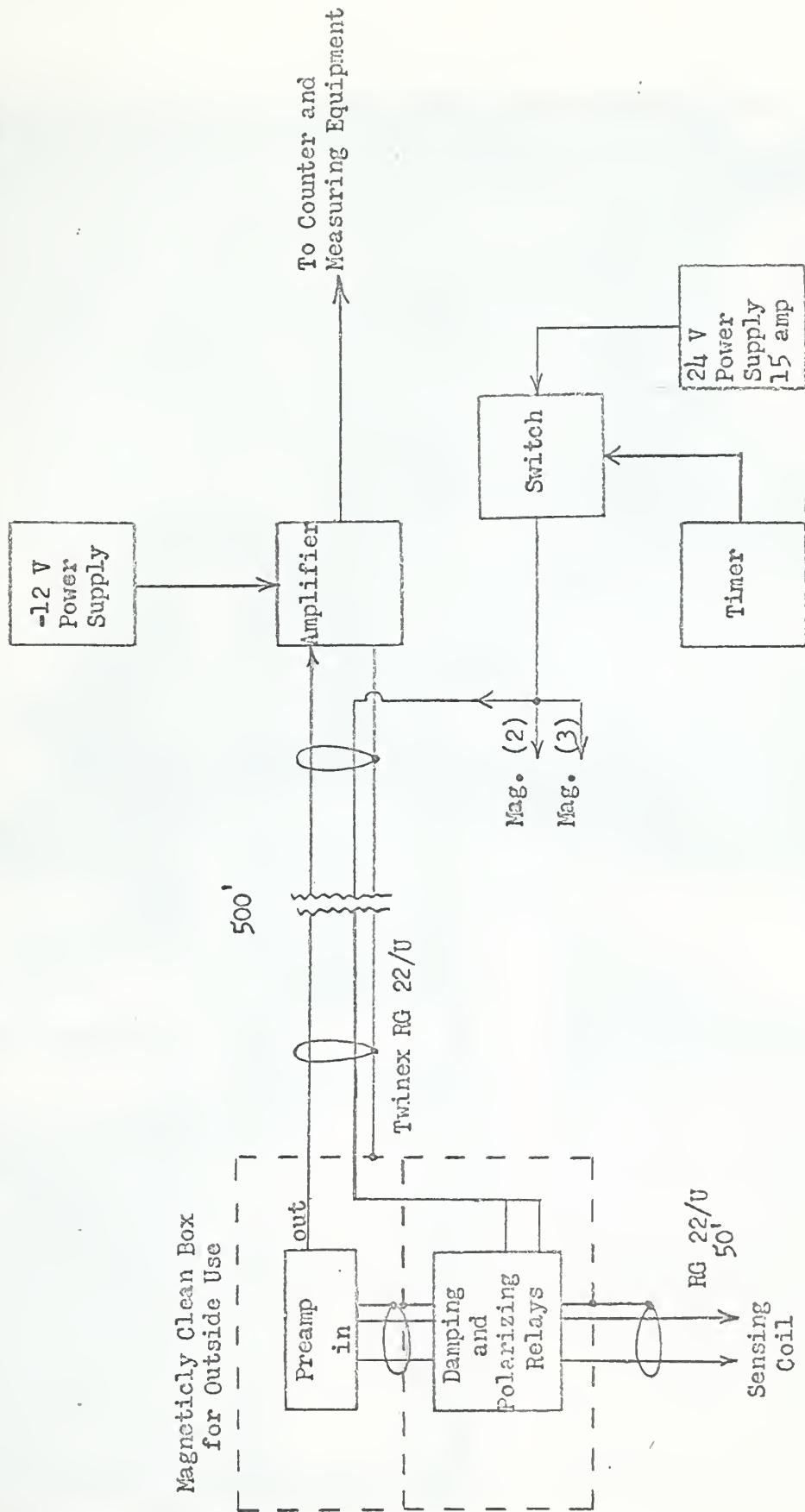

Figure 4

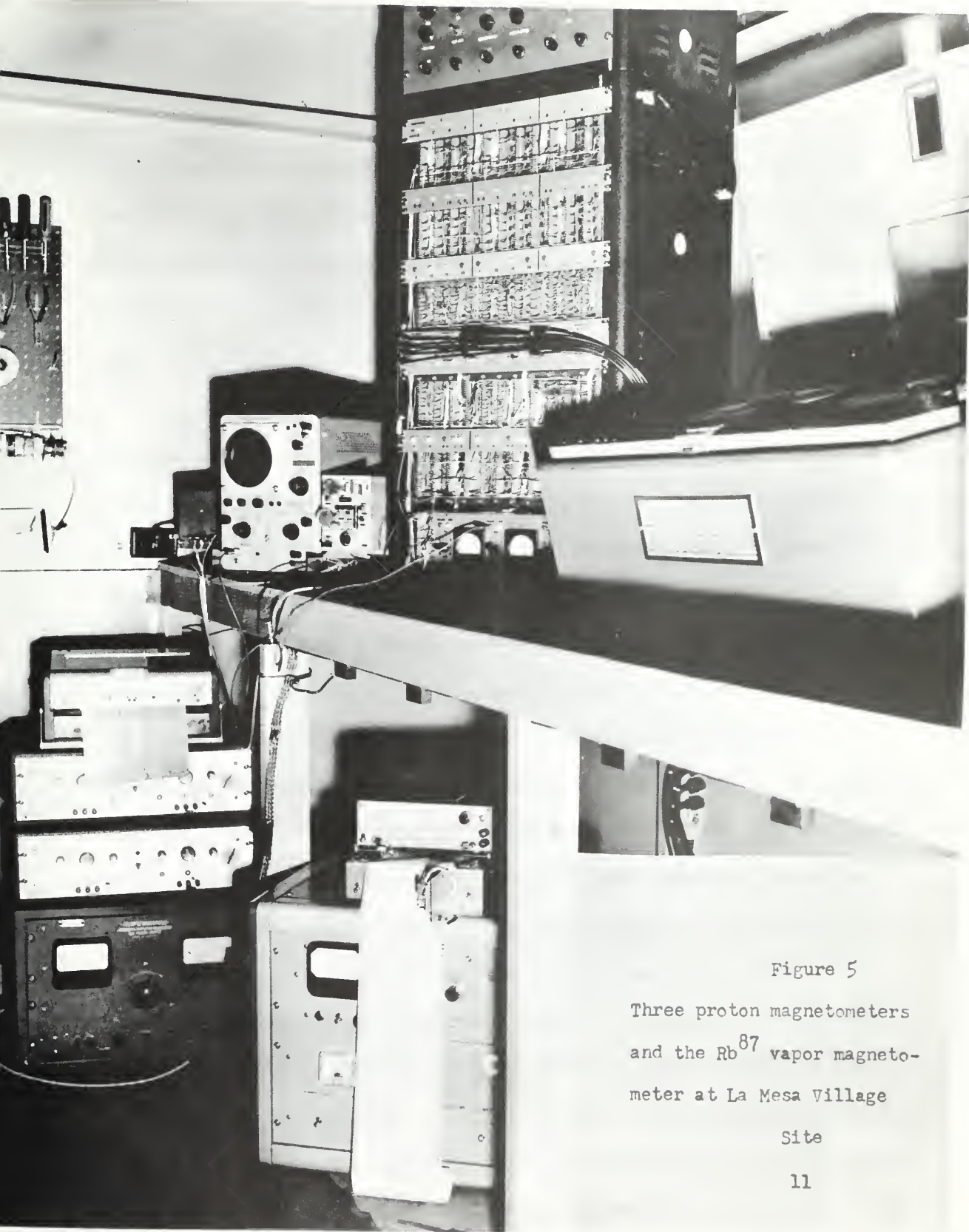

Figure 5
Three proton magnetometers
and the Rb⁸⁷ vapor magneto-
meter at La Mesa Village
Site

2.2 Data Acquisition and Processing

Figure 6 shows a block diagram of the data collection and reproduction system.

The scheme used for data handling is certainly not optimum in the sense of tape utilization and ease of operation, but an Ampex CP100 was available and required no additional expenditure for tape recorder. Also with minor modifications a data recorder can be utilized at a later date if funds become available.

Consider the form of the data. The sensing coils are polarized for one second, at the end of this time the polarizing current is turned off, the transients are damped; and the signal is fed to the counting units. After 1024 cycles of the input signal (about 1/2 sec.) the measurement is complete. In the fast counters, there are three binary numbers to be processed. The magnitude of the binary numbers, for $H = 50950 \text{ } \gamma$ with clock frequency $\approx 100 \text{ kc/s}$, is about 001341146_8 or 16 bits. With the clock increased to 300 kc/s , the number is 00425260_8 or 18 bits. Hence, at the end of the counting interval, there are 48 bits to be recorded in a format for computer input. The Ampex CP100 is a "portable" instrumentation recorder with 14 parallel inputs and capable of speeds from $1 \frac{7}{8}$ ips to 60 ips. All of the record and reproduce amplifiers that were on hand were not capable of recording D.C. levels; therefore, the information was put on tape in the form of pulses. Also, for reasonable speed in reproduction, the data was recorded at $1 \frac{7}{8}$ ips and reproduced at 60 ips. A record of approximately 6.5 hours can be reproduced in 10 minutes. The machine used to read the raw data is a CDC160 com-

DATA AQUISITION AND PROCESSING

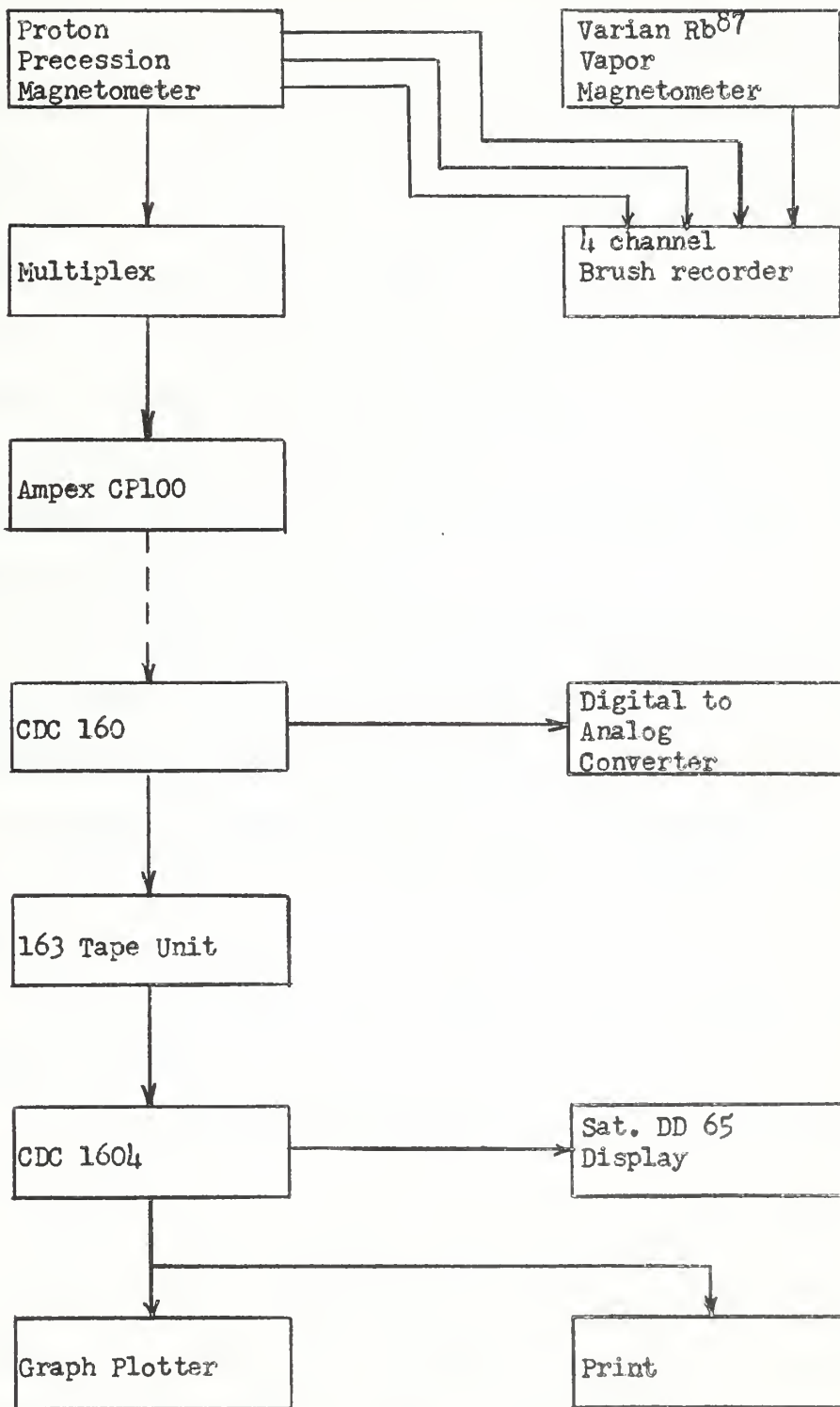

Figure 6

puter capable of reading words of up to 12 parallel bits. The magnetometer words are broken into two, 12 bit words and time multiplexed on tape to satisfy the computer input conditions. Hence, for each sample, there are six 12 bit words to be processed. Even with the time speed up in reproduction the CDC 160 is operating below its capabilities. In an effort to utilize the 160 time, the data was put on tape, so that when it occurred, the 160 would read at its maximum rate and use the "no data time" to continue with preliminary processing. Channels 13 and 14 on the tape are input ready and disconnect signals used to control the 160. And of course, for reasonable machine time efficiency, there is on hand enough tape to allow continuous recording for one week.

The Ampex CP100 was not designed specifically for this type of operation; hence the need for an interface to mate it with the 160. The interface must provide the following functions:

- a. Convert the pulse type data to D.C. level signals.
- b. Put the data on line when a request is supplied from the computer.
- c. Effectively disconnect itself from the lines when other equipment is called.
- d. Provide control information, i.e. input ready and disconnect for the 160.
- e. Effectively isolate the computer from spurious transients from the tape machine. These normally occur during start - stop operations, but the recorder is somewhat susceptible to power line transients and they sometimes appear in its output.

Figures 8, 9 and 10 shows the block diagram of the interface provided. Fig. 11 is a photo of the preliminary processing setup. The cards were assembled and mounted as a component on a laboratory cart, the tape unit is placed on the top of the cart and computer cable connectors provided. This eliminates the need for a permanent rack in the computer laboratory.

The preliminary processing consists of the following:

- a. Reading the raw data.
- b. Checking the data and keeping a record of the errors.
- c. Writing the storage tape.
- d. Providing identifying blocks on the storage tape.
- e. Searching the storage tape for any particular record or the end of the data so that one storage tape may be used for many week's records.
- f. Direct display of the raw data.

The data storage format used is illustrated in Fig. 7.

STORAGE TAPE FORMAT

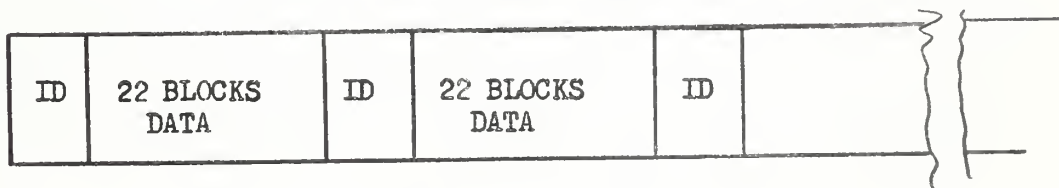
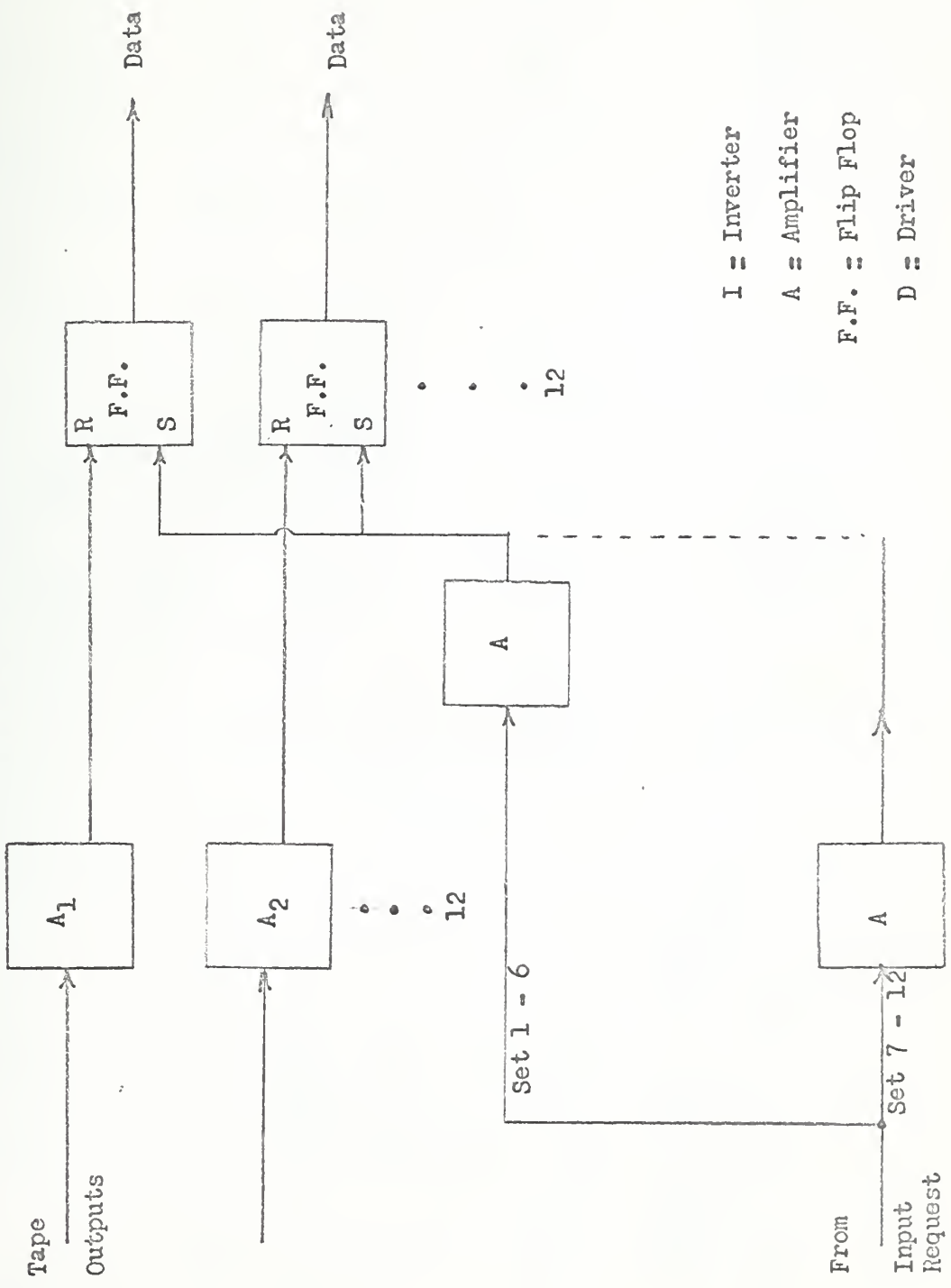

Figure 7

With the time base used there are nearly 38040 twelve bit words per 6.5 hours record. The 6.5 hours record is one 3600 roll of instrumentation tape at 1 7/8 ips. Since the operation is stopped to change tape, it is convenient to put the identifying block at the

TAPE DECK OUTPUT REGISTER



- I = Inverter
- A = Amplifier
- F.F. = Flip Flop
- D = Driver

Figure 8

INTERFACE INPUT SECTION

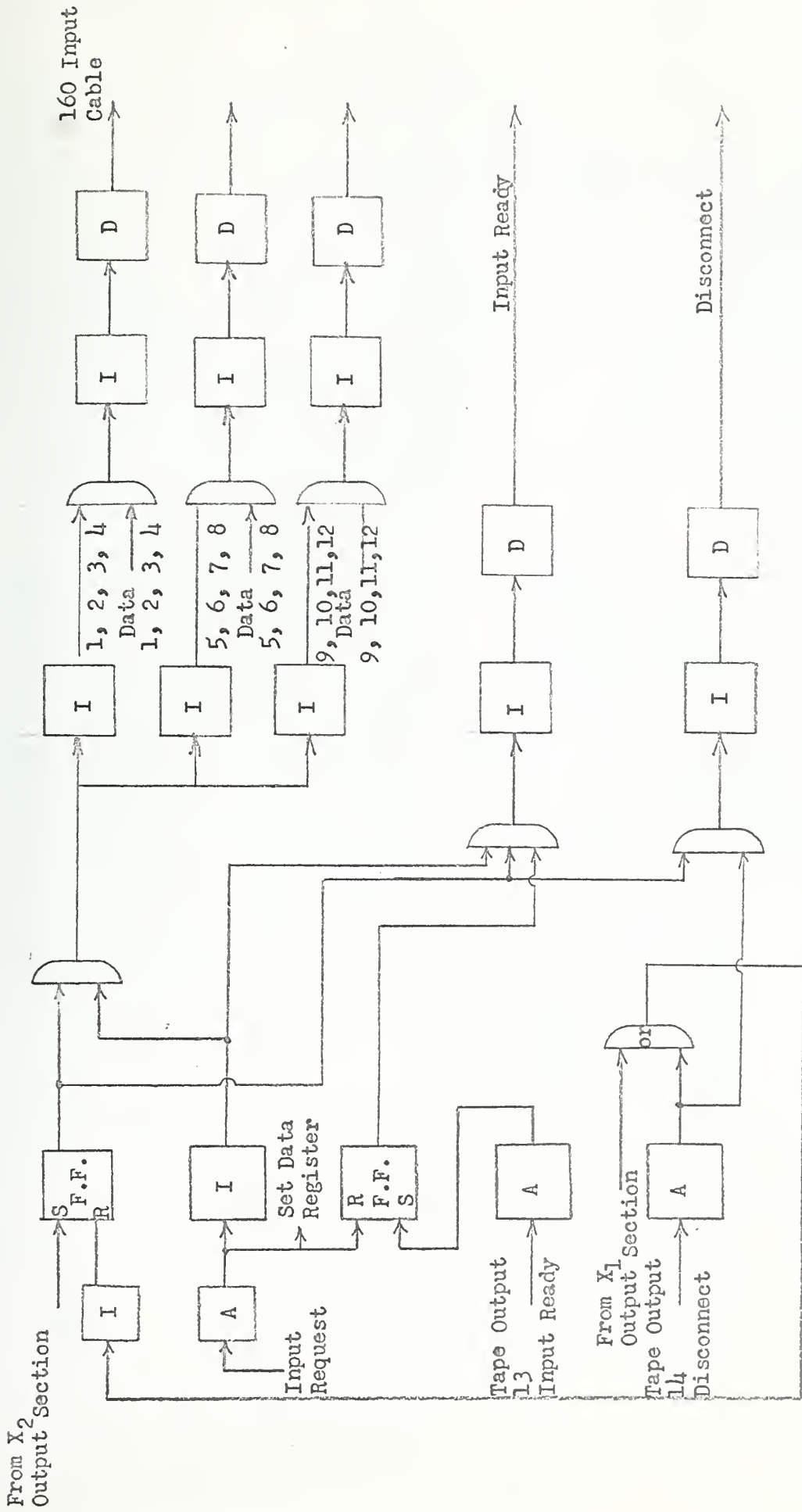

Figure 9



Figure 11
Preliminary processing setup

end of this record. Also, this number of data words can be processed in the order of minutes by the CDC1604 so that if the computer is needed for other jobs; it can be stopped at the identifying blocks and return later to the same point with the proper index setting. The block length was set somewhat arbitrarily. The memory storage limit of the 160, write time of the 163 tape unit and suitable records for handling in the 1604, are the factors to be considered when choosing the block length. The instrumentation recorder cannot conveniently be stopped when writing the storage tape; hence one data point is lost when transferring data. This represents 22 points per 6.5 hours record or less than a minute in real time. The block length was chosen to be 3456_{10} twelve bit words per block, the figure being compatible with the above conditions.

The identifying record consists of writing the month, day and year in flex code. The remaining cells of the block are loaded with zeros. It is then easy to separate the data from the identifying blocks since none of the data words will be all zeros.

The fact that the data had to be reconstructed in the 1604 was also considered in choosing the block length. The information is buffered into the 1604 in 48 bit words. The blocks consist of an even number of data points, i.e. six 12 bit or two 48 bit words. After a block is read into the machine and loaded into the A register, the magnetometer readings can be stored sequentially in memory with a loop of a few machine language instructions. The data analysis is then done using Fortran, allowing easy and versatile manipulation of the data. The 160 and 1604 input programs are included in Appendices II and III.

Reassembly is illustrated below.

1604 WORDS

Mag 1 (24 bits)	Mag 2 (24 bits)
Mag 3 (24 bits)	Mag 1 (24 bits)
Mag 2 (24 bits)	Mag 3 (24 bits)

Briefly, the operation is as follows: Magnetometer readings are recorded for long periods of time at a remote site on a portable magnetic tape unit. The tape unit is then returned to the processing site, and using a time speed up of X 32, the intermediate processing is performed and the data stored.

The storage tape along with suitable programs is then placed on file for processing by the computer facility at their convenience. The tape unit is then returned to magnetometer site for more records. The new data obtained is added to the storage tape so as not to destroy the existing data.

3. Data Analysis

The experimental measurement program was set up to study the coherence between the magnetometers, i.e. the comparison of simultaneous samples of the field, with the sensors located at different spatial locations. The coherence was to be examined with various local perturbations in the field. With the target detection objective in mind, the least complicated method of obtaining the target signal will result in the best instrumentation for field use. The problem is somewhat analogous to the radar problem where decisions must be made in the presence of noise, with associated probabilities of error in detection.

There are several types of geomagnetic noise that occur. The most dominant is the diurnal variations. Superimposed on this are smaller variations known as micropulsations and noise caused by local disturbances. Sudden eruptions on the sun sometimes cause large fluctuations in the field. Several studies of the various noises have been made (3), (4) and (5). For the proton precession magnetometer, the instrument produces noise of major contribution to the spectra of small geomagnetic pulsations. For target detection, the signal of interest will most likely be of the same order of magnitude as the small micropulsations and local disturbances. For geophysical prospecting and mapping, the signals will be much larger.

As with any raw data, there will be some points that are obviously in error. The cause of errors is usually uncertain, but some provision must be made in the processing to eliminate these errors so as not to distort the data. Care must be taken when performing

these operations so the target signals are not masked. Records of the errors should be kept in order that decisions about the usefulness of the set of data can be made.

The problem of coherence between the spatial samples requires that the instrument noise be determined, with an ideal signal, then measurements be conducted with no local perturbations in the field, and the samples compared. The simplest comparison is to plot the difference signal vs. time. With no local perturbation, this means essentially a plot of the system noise vs. time; hence the need for filtering is obvious. To use this method for target detection will require serious consideration of the filter time constants.

The types of filtering

1. A clipping filter (on the raw data) that clipped at $\pm 200 \%$. The number of points outside of this range are recorded. This range was about twice the expected diurnal variation. The filter removes the errors from lost high order bits and other instrument sources. The typical error rate was about 1/50000.

2. A simple three point average for display of the raw data on the DD 65 display unit was used. This gives an operator a fast visual display of the raw data. Decisions can then be made about the quality of the data.

3. Eighteen point averaging, i.e. 36 seconds real time, gave partially smoothed 6.5 hours graph records.

4. A simple single section low pass filter was used of the form $1/(s - a)$. The time constant was set at 100 sec. and 20 min. in real time. The implementation was done using Z transform (6).

The filter design was done by Professor Harold A. Titus.

We have

$$\frac{X_o(S)}{X_{in}(S)} = \frac{a}{s - a}$$

which has a Z transform

$$\frac{X_o(Z)}{X_{in}(Z)} = \frac{\beta}{1 - e^{-aT} Z^{-1}}$$

In block diagram form this is seen in Fig. 29

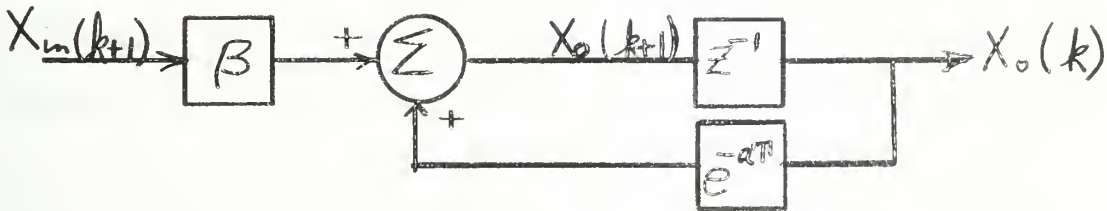

Figure 29

In terms of the discrete time samples we have

$$X_o(k+1) = \beta \sum_{n=0}^k e^{-a n T} X_{in}(k+1-n)$$

$$\beta = \frac{1}{\sum_{n=0}^k e^{-a n T}}$$

T = sample period

a = time constant

The function was truncated at $n \approx 20$ for values of $k > 20$.

The contribution to the filtered value from the terms multiplied by e^{-anT} for $n > 20$ is negligible.

The coherency is a statistical parameter, and must be represented as such.

Let:

$$\Delta_1 = H_1 - H_2$$

$$\Delta_2 = H_1 - H_3$$

$$\Delta_3 = H_2 - H_3$$

The differences of the unfiltered values were grouped in a frequency distribution which approximates the continuous density function for large sample size. Since the process is digital, the allowable differences, in bits are: $0, \frac{1}{2}, 1, \frac{3}{2}, 2, \dots$. Therefore, the frequency distribution is not a smooth curve. Since the instrument noise is randomly distributed, the envelope of the distribution is a normal density function. The mean was removed before plotting, and the statistic representing the standard deviation was computed according to:

$$s = \frac{1}{N} \sqrt{\sum_{i=1}^N (\Delta_i - \bar{\Delta})^2}$$

where: $N =$ the number of samples in a 6.5 hour record.

Comparison of the density function curve with an ideal signal input to that of magnetometer input gives a measure of the noise produced by the device.

To further define the coherence, the auto and cross correlation functions were computed and the coherency computed as defined:

$$\text{cch}_{11} = \frac{\phi_{12}}{\sqrt{\phi_{11} \phi_{22}}}$$

where:

$$\phi_{12}(\tau) = \lim_{T \rightarrow \infty} \int_{-T/2}^{T/2} x(t) y(t+\tau) dt$$

and

$$\phi_{11}(\tau) = \lim_{T \rightarrow \infty} \int_{-T/2}^{T/2} x(t) x(t+\tau) dt$$

This discrete computational form is

$$C_{xy}(\tau) = \frac{1}{N-n} \sum_{p=1}^{N-n} x_p y_{p+\tau}$$

and

$$C_{xx}(\tau) = \frac{1}{N-n} \sum_{p=1}^{N-n} x_p x_{p+\tau}$$

where:

N = number of data values

n = number of lags

$\tau = n \Delta t$

Since the functions are from finite time series n_{\max} can only be made about $0.1 N$. The 6.5 hour records will vary in form depending upon the time of day the records were made. Therefore, the correlation

functions will not be the same shape for each record; however the coherence function as defined will be the same, and for perfectly coherent records is unity. The programs are included in Appendix III.

It should be pointed out that when perturbations are placed in the field, the basic assumptions regarding correlation; i.e. a stationary random process, are no longer applicable.

Experimental data was taken to determine typical signatures for elementary perturbations. Fig. 12 shows the geometry of the detector centered coordinate system.

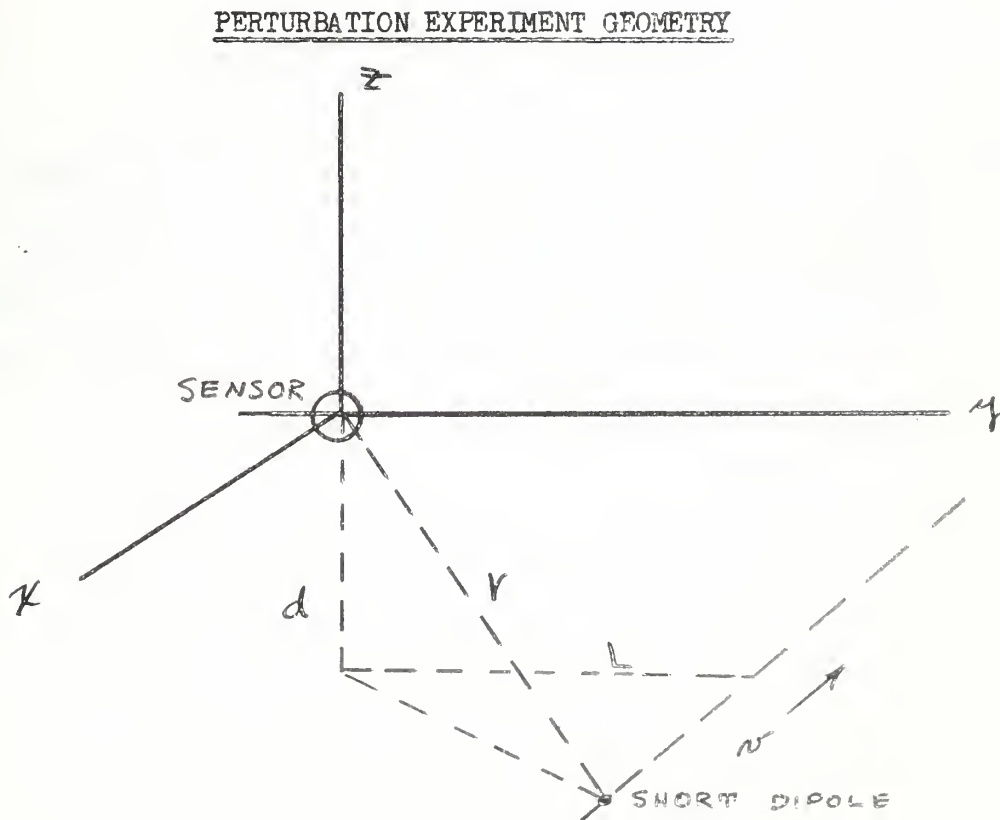

Figure 12

The dipole moment was orientated parallel to the earth's field and its motion was in the x direction such that $dx/dt \approx \text{constant}$. The approximation $r \gg 1$ is valid.

At the detector:

$$H \approx \sqrt{H_o^2 - H_p^2}$$

And:

$$H_p \approx \frac{K M}{r^3}$$

where:

$M \approx$ dipole moment

$r \approx$ function of time and the geometry

$K \approx$ constant

No attempt was made at this time to compare the measured values with the theoretical values, because the terrain does not lend itself keeping L , d , and v constant. The results are representative of typical signatures that would be found in practice.

4. Results

4.1 Instrumentation:

An ideal signal was substituted for the procession signal and set of records were made, as shown in Figs. 13 through 25. The graph scales were left unchanged because it was desired to show the instrument errors on the same scale as the magnetic field scales. The magnetic field vs. time graphs were not included because the input signal was an audio oscillator and only a small drift puts it off the graph scale. The clock was 300 kc/s which makes 1 bit \approx 0.36 γ .

Figure 28 shows the precession signal from the various sensors. Figs. 26 and 27 are typical plots made from the analog section of the instrument. For comparison, the Rb⁸⁷ magnetometer output was adjusted to the same scale and plotted on the same graph. The Rb⁸⁷ magnetometer output is an analog of frequency, while the proton magnetometer the analog is of period; hence the reason for the opposite drift on the chart. Figure 27 is an analog record of the differences. The filter was a single section RC filter with time constant \approx 10 sec. On the multiple curve plots showing coherence, the curves are identical and cannot be distinguished from each other. These curves can be compared with the curves obtained from the sensor with no local perturbations in the field, for the contribution of the measuring instrument noise to the total noise.

Difficulties with both instrumentation and computer tape have been encountered. The use of new computer tape for data storage and scratch tapes, and frequent head cleaning of the instrumentation recorder reduced the difficulties to a minimum.

Differences in magnetic intensity vs. time
for an ideal signal input.

$$\text{DEL1} = H_1 - H_2$$

$$\text{DEL2} = H_1 - H_3$$

$$\text{DEL3} = H_2 - H_3$$

Filter = 18 point average

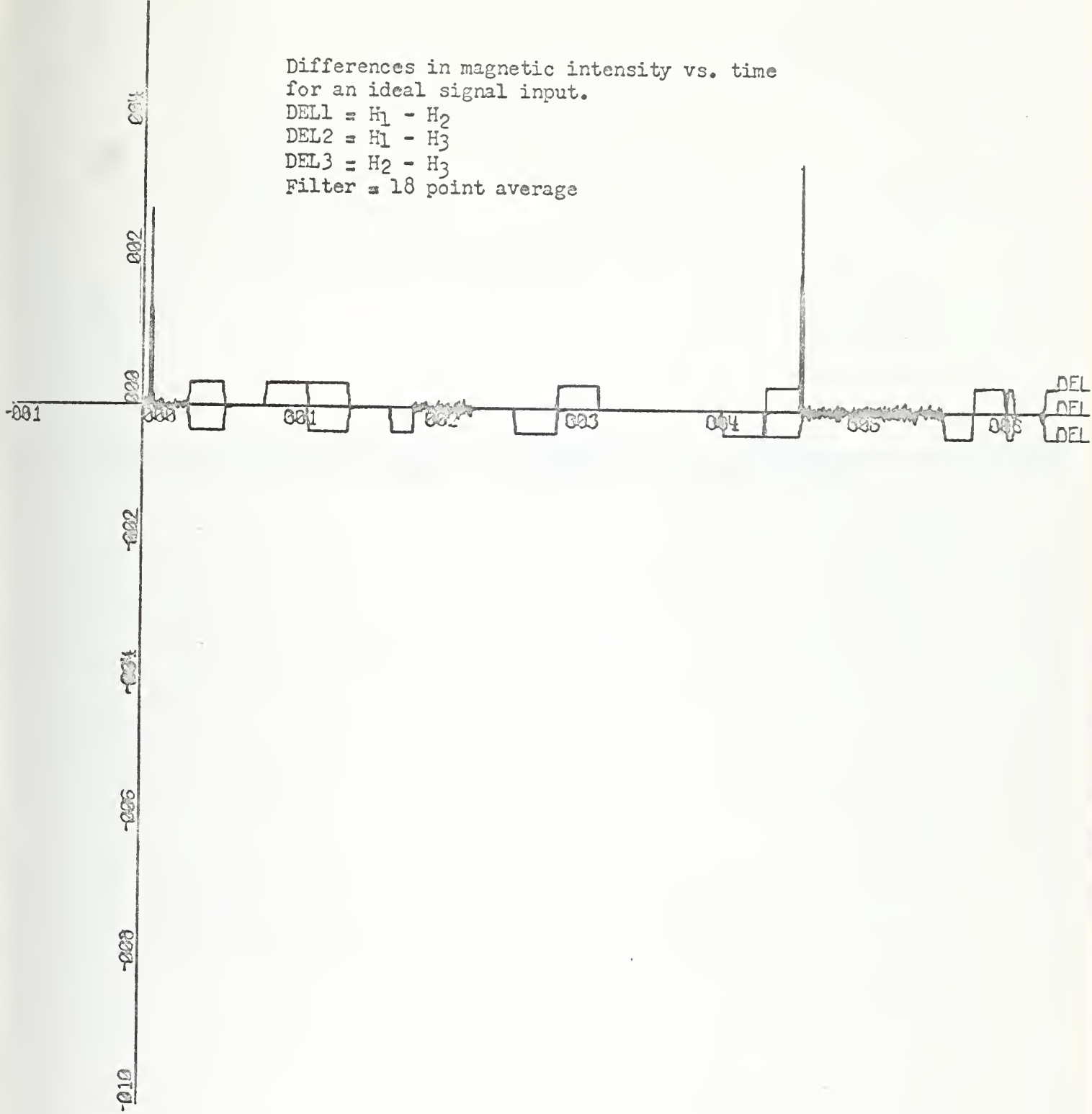

Figure 13

X-SCALE = 1.00E+00 UNITS/INCH

Y-SCALE = 2.00E+00 UNITS/INCH

ANDERSON BOX 263

FIRST DIFFERENCE IN MAG FIELD T IN HRS H GAMMA

Differences in magnetic intensity vs.
time for an ideal signal input.

$$\text{DEL 1} = H_1 - H_2$$

$$\text{DEL 2} = H_1 - H_3$$

$$\text{DEL 3} = H_2 - H_3$$

Filter = Z transform low pass with
time constant of 20 minutes.

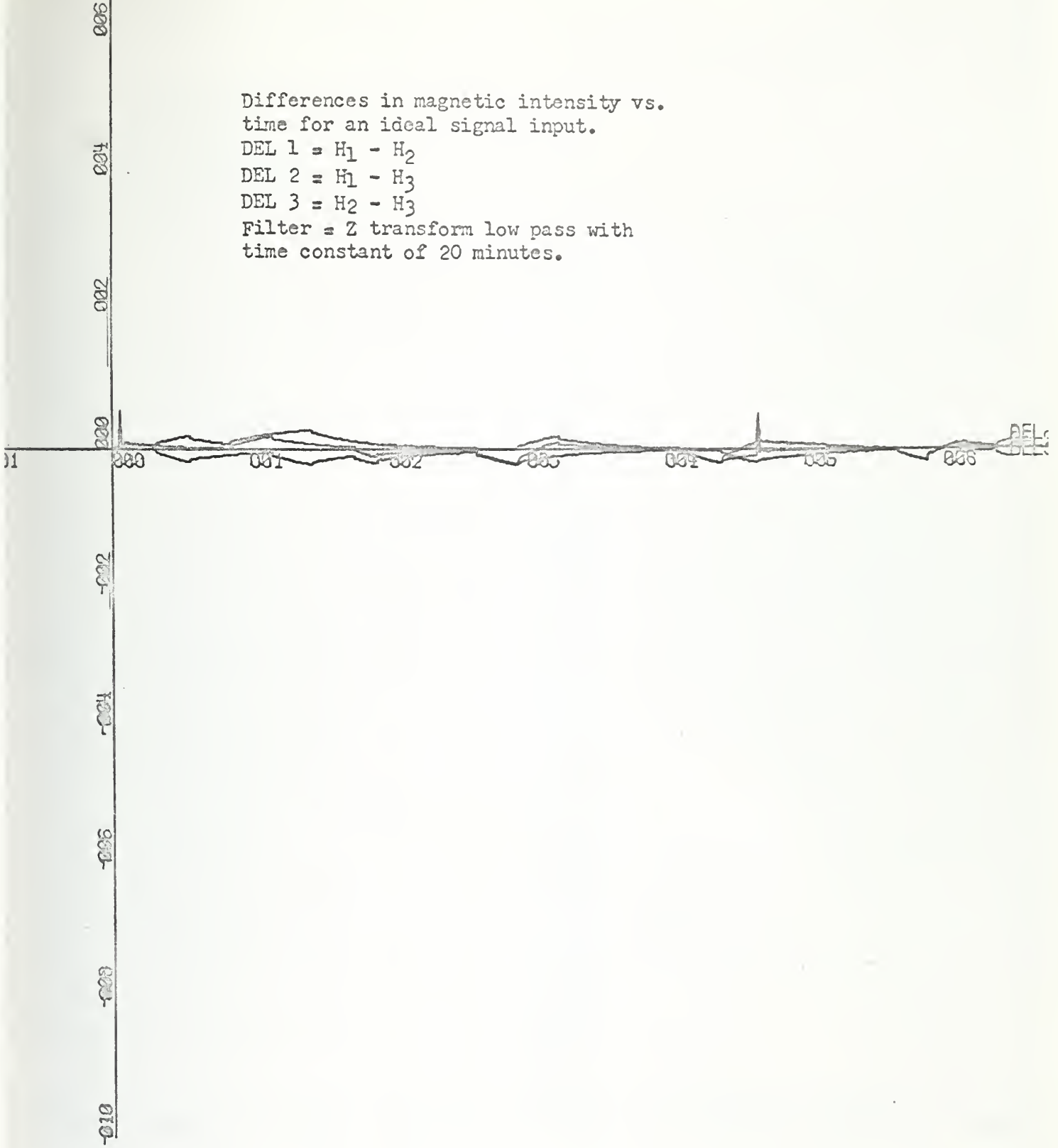

Figure 14

X-SCALE = 1.00E+00 UNITS/INCH.

Y-SCALE = 2.00E+00 UNITS/INCH.

ANDERSON FILTER

FILTERED DIFFERENCE IN MAG FIELD T IN HRS H GAMMA

Normalized density function for the
 difference $H_1 - H_2 - \text{mean}(H_1 - H_2)$,
 with an ideal signal input.
 Mean = 0.061 gamma
 Standard deviation = 0.21

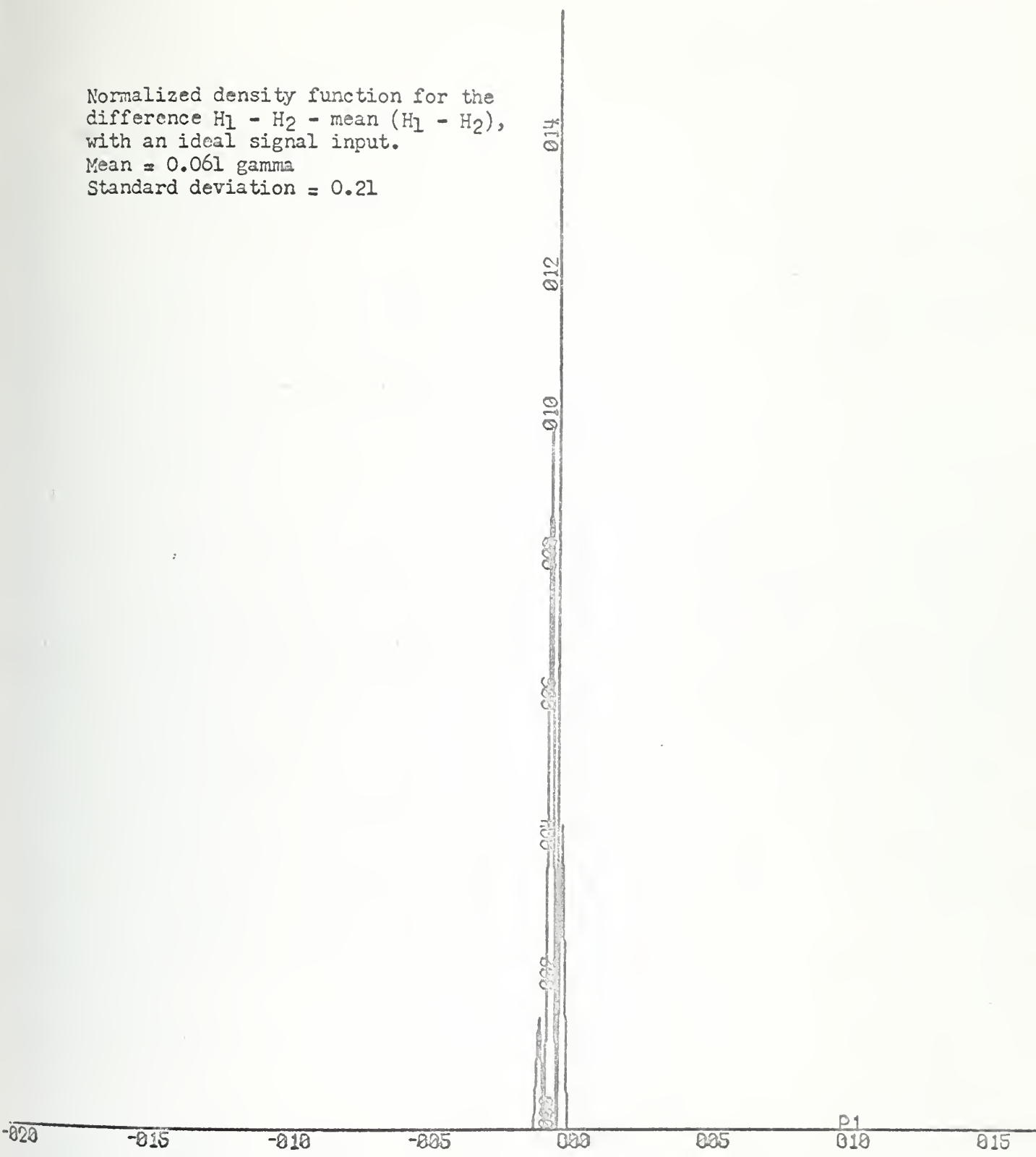

Figure 15

X-SCALE = 5.00E+00 UNITS/INCH
 Y-SCALE = 2.00E-01 UNITS/INCH

ANDERSON BOX 263
 DENSITY FUNCTION X IN GAMMA Y IN FREQ

Normalized density function for the
 difference $H_1 - H_3 - \text{mean}(H_1 - H_3)$,
 with an ideal signal input.
 Mean = 0.056 gamma
 Standard deviation = 0.72

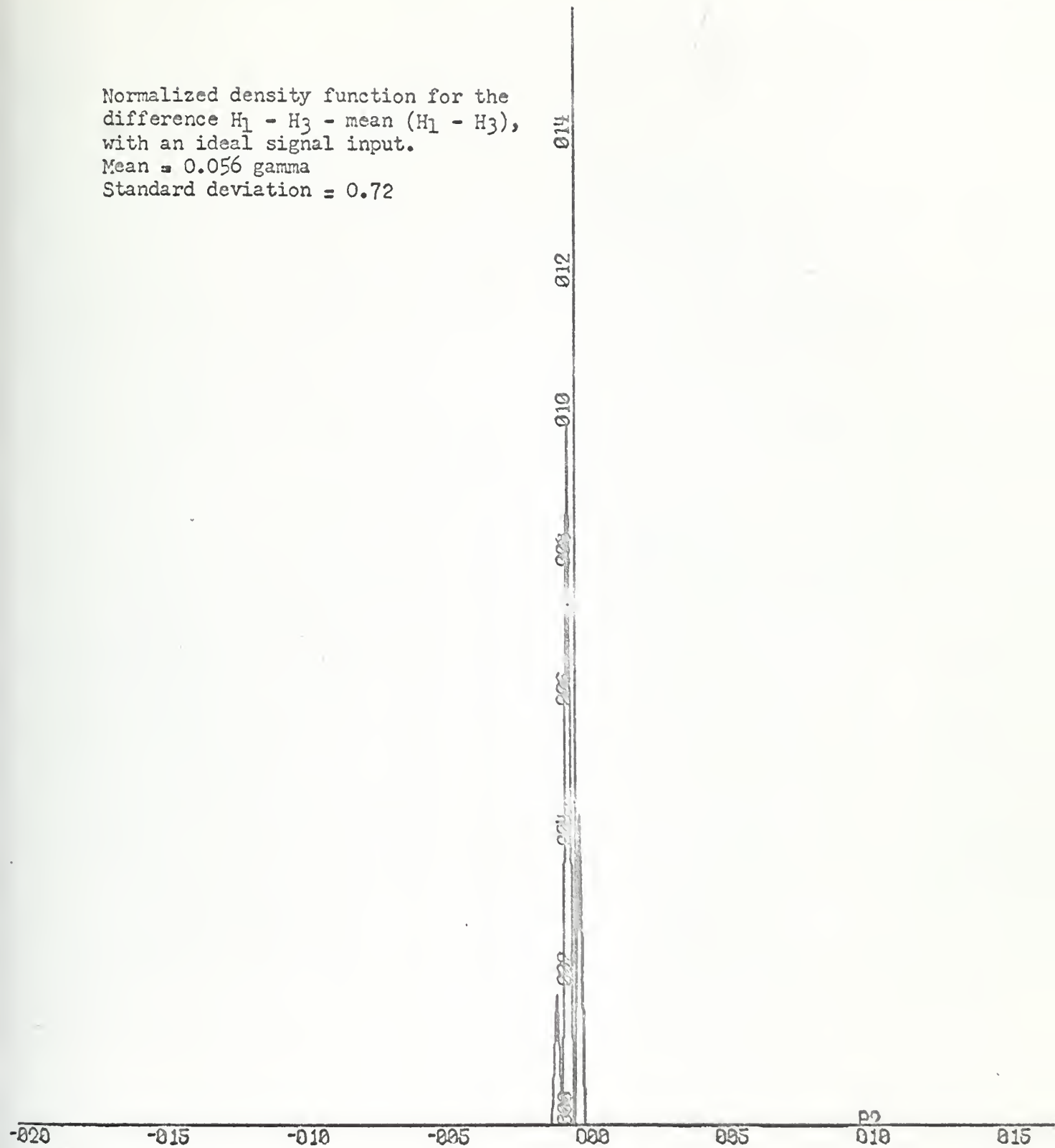

Figure 16

X-SCALE = 5.00E+00 UNITS/INCH.

Y-SCALE = 2.00E-01 UNITS/INCH.

ANDERSON BOX 263

DENSITY FUNCTION X IN GAMMA Y IN FREQ

Normalized density function for the
 difference $H_2 - H_3 - \text{mean}(H_2 - H_3)$,
 with an ideal signal input.
 Mean = -0.0055 gamma
 Standard deviation = 0.72

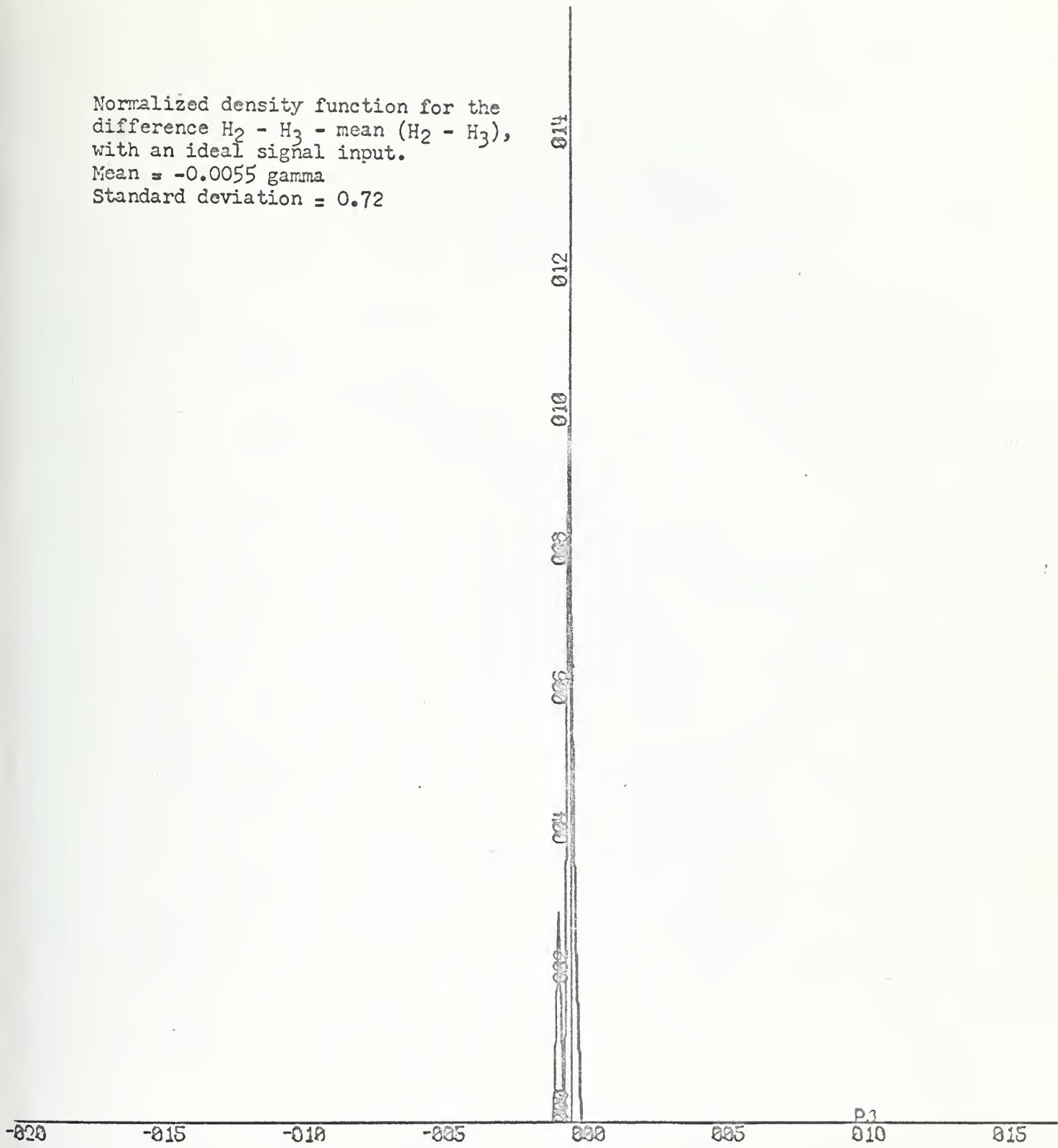

Figure 17

X-SCALE = 5.00E+00 UNITS/INCH.

Y-SCALE = 2.00E-01 UNITS/INCH.

ANDERSON BOX 263

DENSITY FUNCTION X IN GAMMA Y IN FREQ

Auto correlation for an ideal
signal input.

Record length = 6.5 hours

H_1 = Correlation (H_1 - mean H_1)

H_2 = Correlation (H_2 - mean H_2)

H_3 = Correlation (H_2 - mean H_3)

Lag = Δt

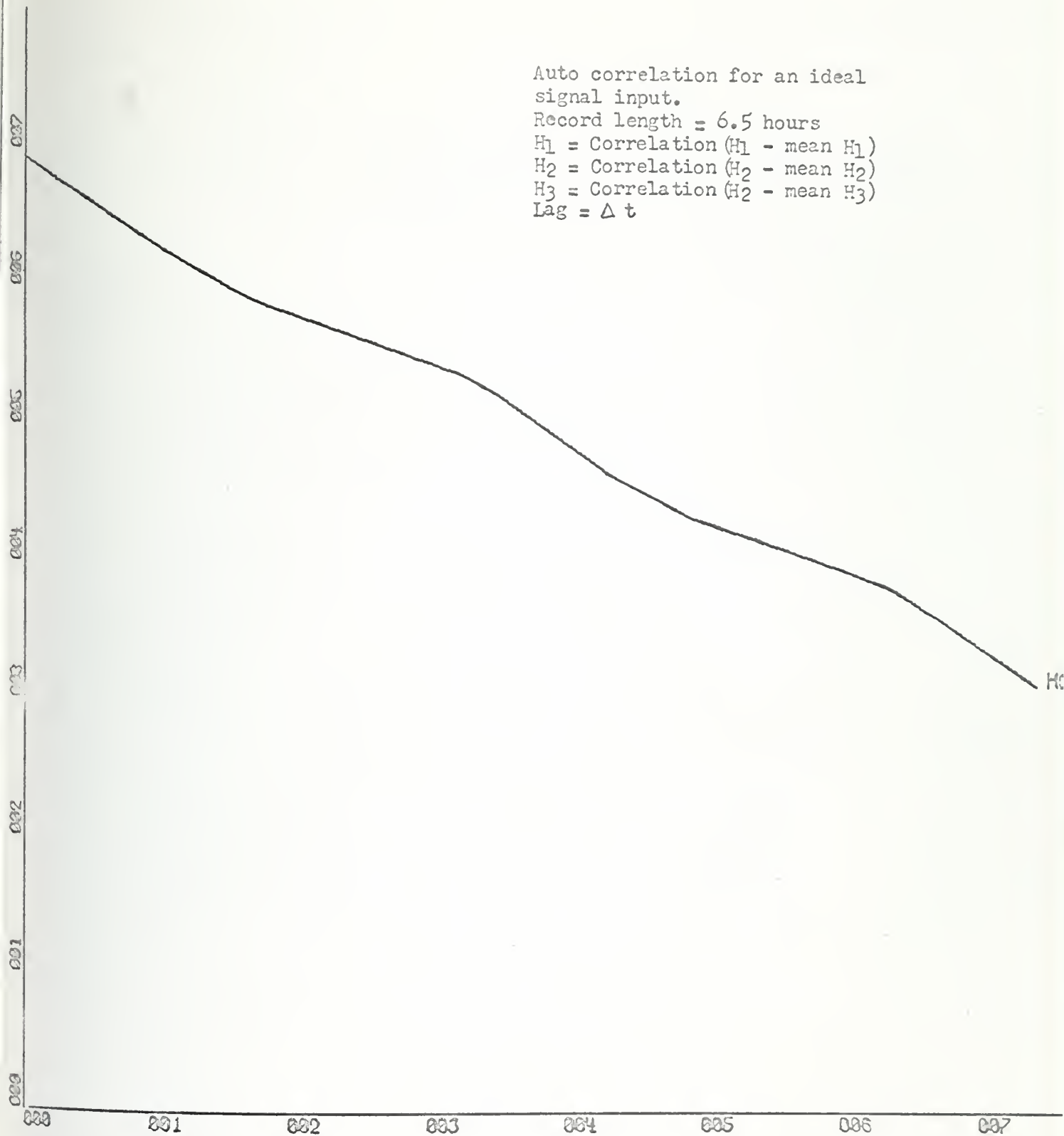

Figure 18

X-SCALE = $1.00E+01$ UNITS/INCH

Y-SCALE = $1.00E+04$ UNITS/INCH

ANDERSON BOX 263

AUTOCORRELATION FUNCTION Y IN PRODUCTS X IN LAGS

Cross correlation for an ideal
signal input.

Record length = 6.5 hours

H_{12} = Correlation (H_1 - mean H_1 and H_2 - mean H_2)

H_{13} = Correlation (H_1 - mean H_1 and H_3 - mean H_3)

H_{23} = Correlation (H_2 - mean H_2 and H_3 - mean H_3)

Lag = Δt

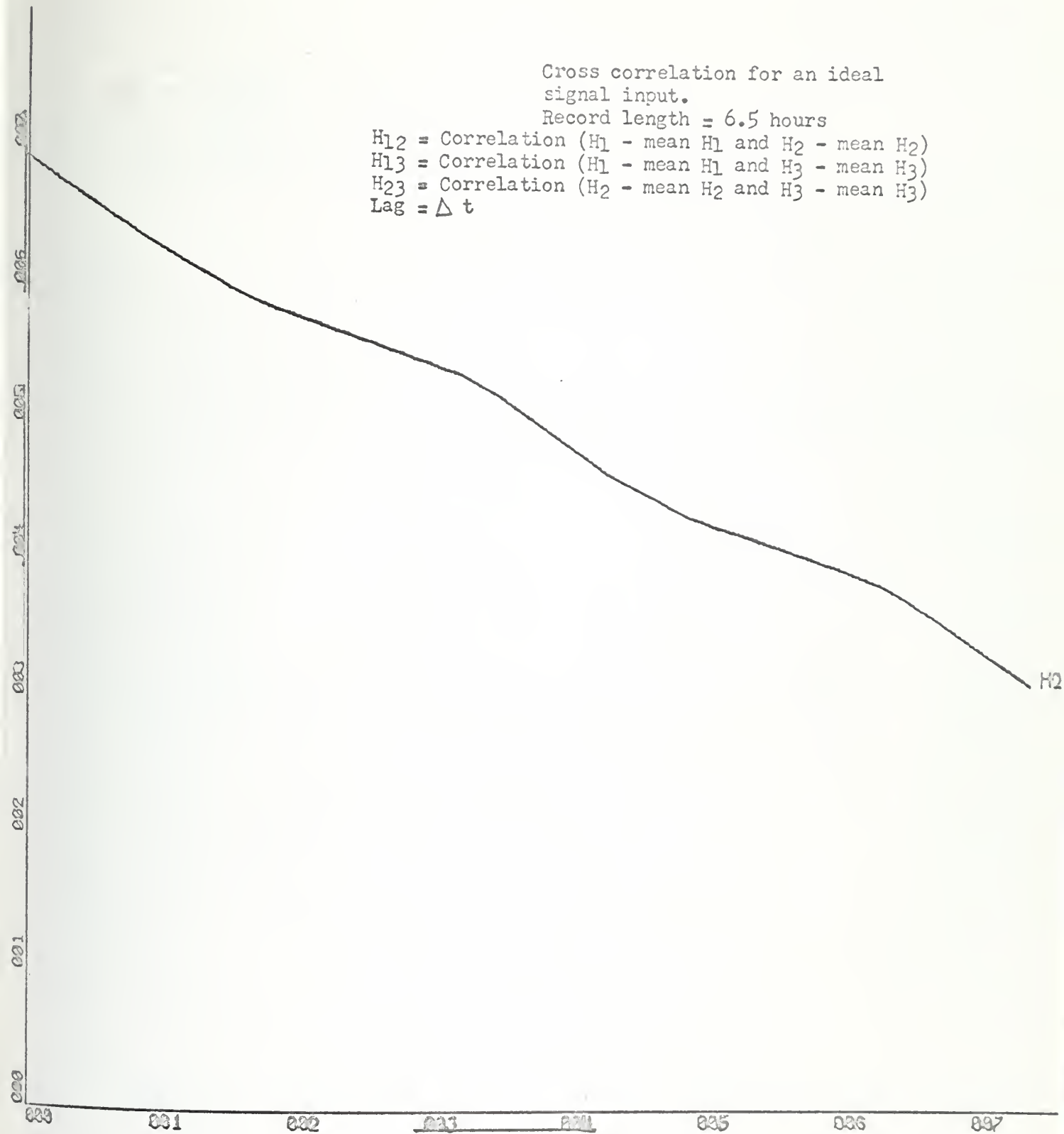

Figure 19

X-SCALE = $1.00E+01$ UNITS/INCH

Y-SCALE = $1.00E+04$ UNITS/INCH

ANDERSON BOX 263

CROSCORRELATION FUNCTION Y IN PRODUCTS & IN LAGS

Coherence for an ideal signal input

Record length = 6.5 hours

H₁₂ = Coherence of H₁ and H₂

H₁₃ = Coherence of H₁ and H₃

H₂₃ = Coherence of H₂ and H₃

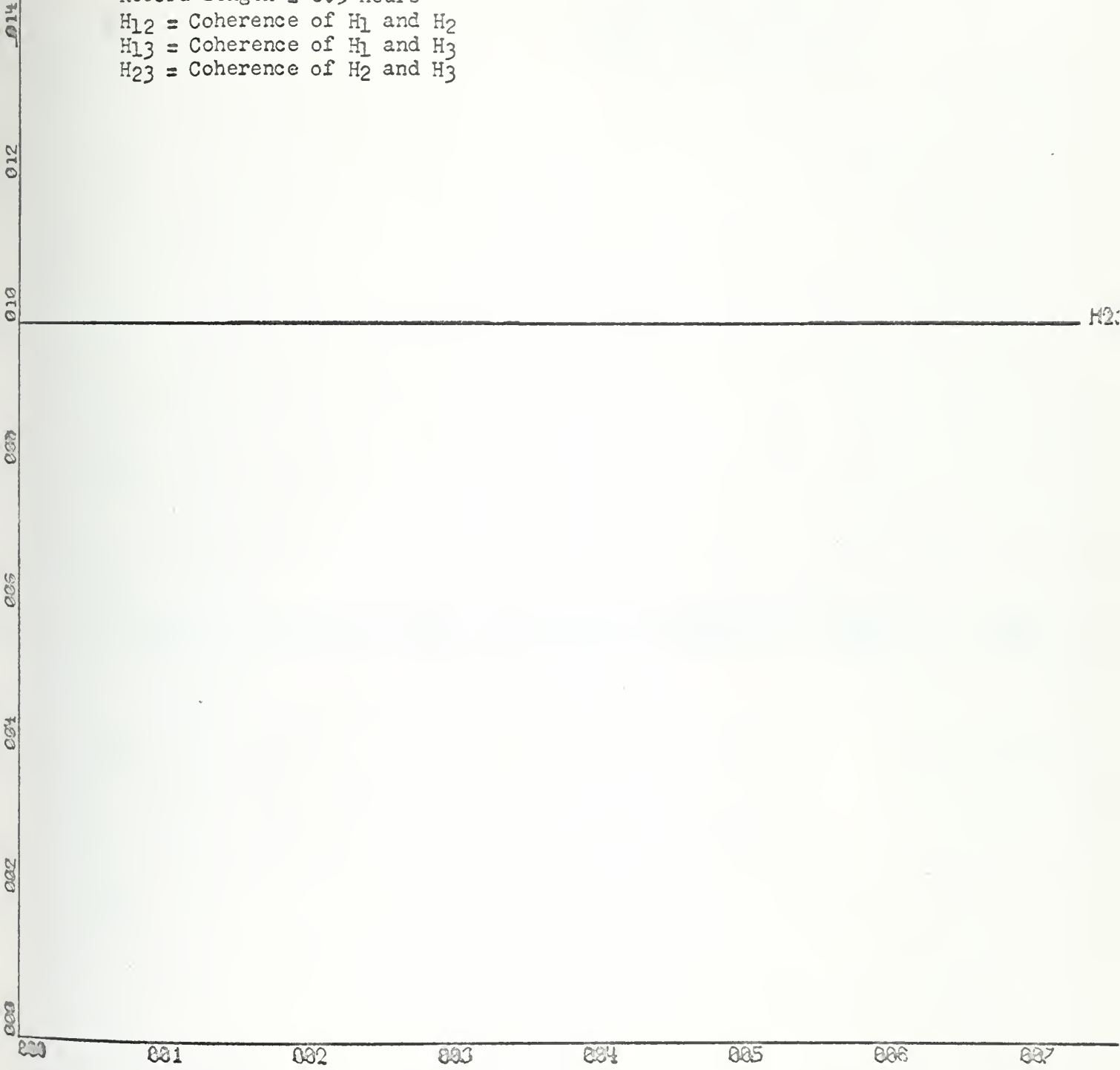

Figure 20

X-SCALE = 1.00E+01 UNITS/INCH

Y-SCALE = 2.00E-01 UNITS/INCH

ANDERSON BOX 263

COHERENCE

FUNCTION Y IN COH X IN LAGS

Differences in magnetic intensity
for an ideal signal input
Record length = 1 hour
Filter = 2 point average

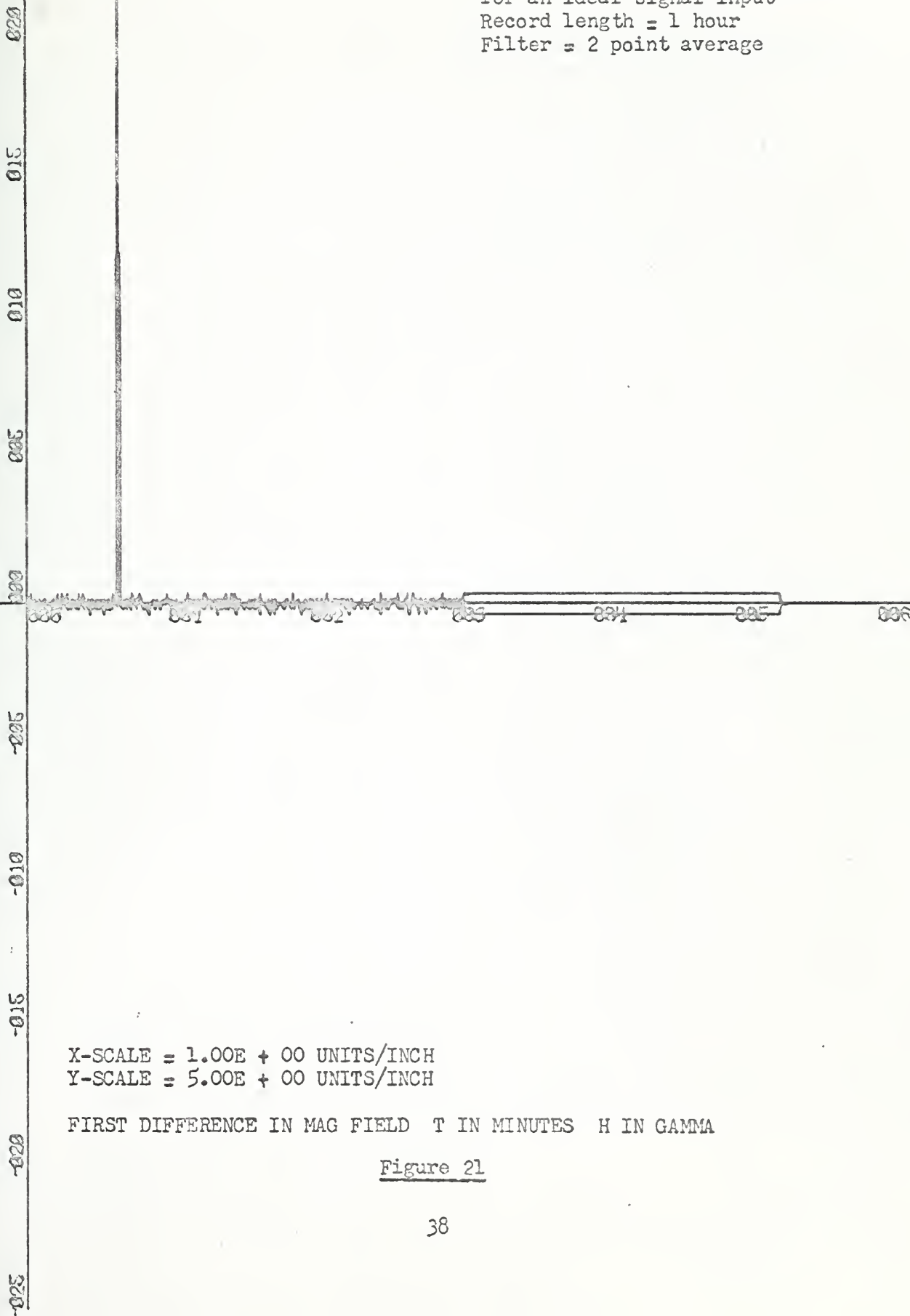

X-SCALE = 1.00E + 00 UNITS/INCH
Y-SCALE = 5.00E + 00 UNITS/INCH

FIRST DIFFERENCE IN MAG FIELD T IN MINUTES H IN GAMMA

Figure 21

Difference in magnetic intensity
for an ideal signal input
Record length = 1 hour
Filter = Z transform low pass
with time constant of 100 seconds.

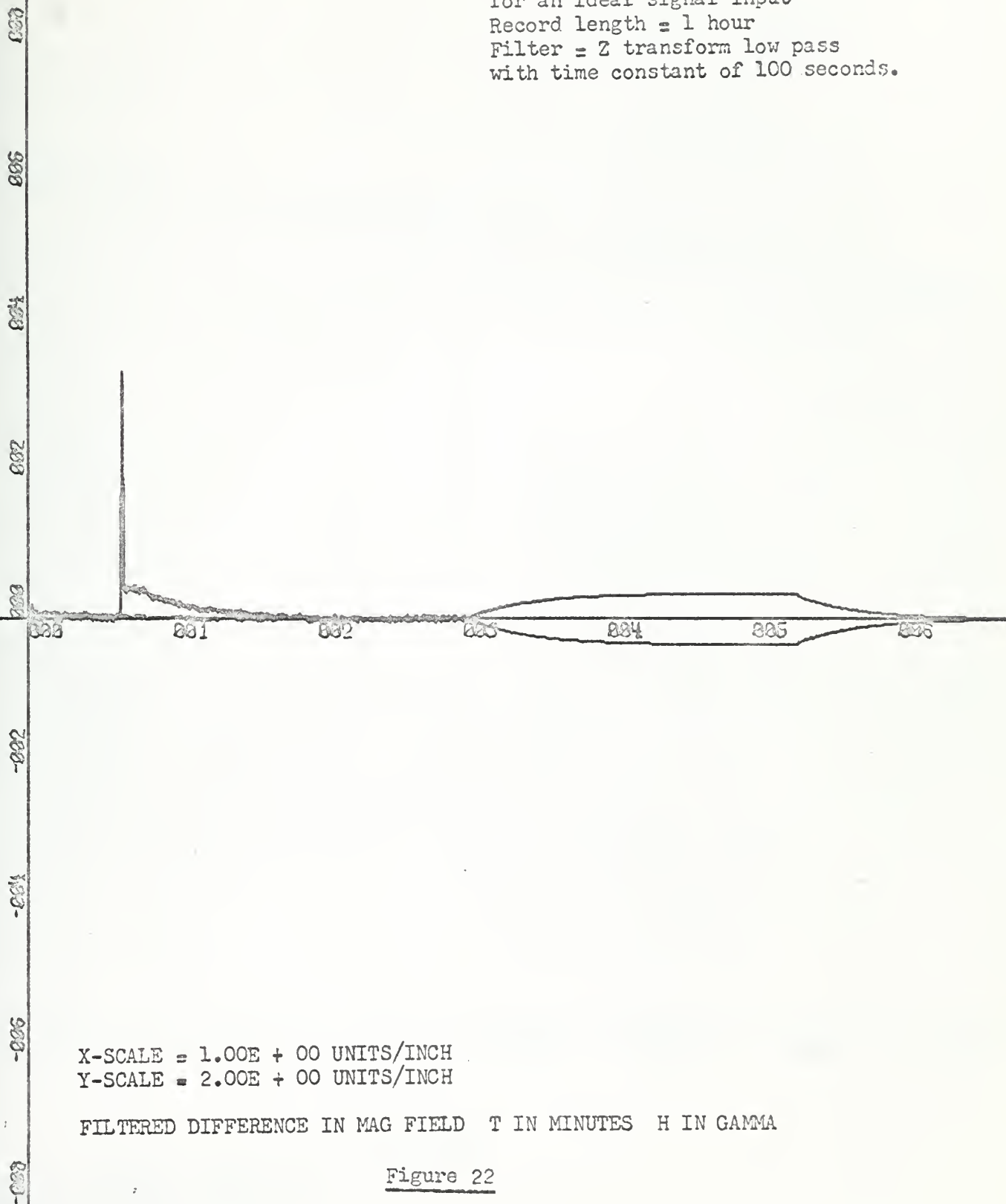

X-SCALE = 1.00E + 00 UNITS/INCH
Y-SCALE = 2.00E + 00 UNITS/INCH

FILTERED DIFFERENCE IN MAG FIELD T IN MINUTES H IN GAMMA

Figure 22

Auto correlation for an ideal
signal input.

Record length = 1 hour

H_1 = Correlation (H_1 - mean H_1)

H_2 = Correlation (H_2 - mean H_2)

H_3 = Correlation (H_2 - mean H_3)

Lag = Δt

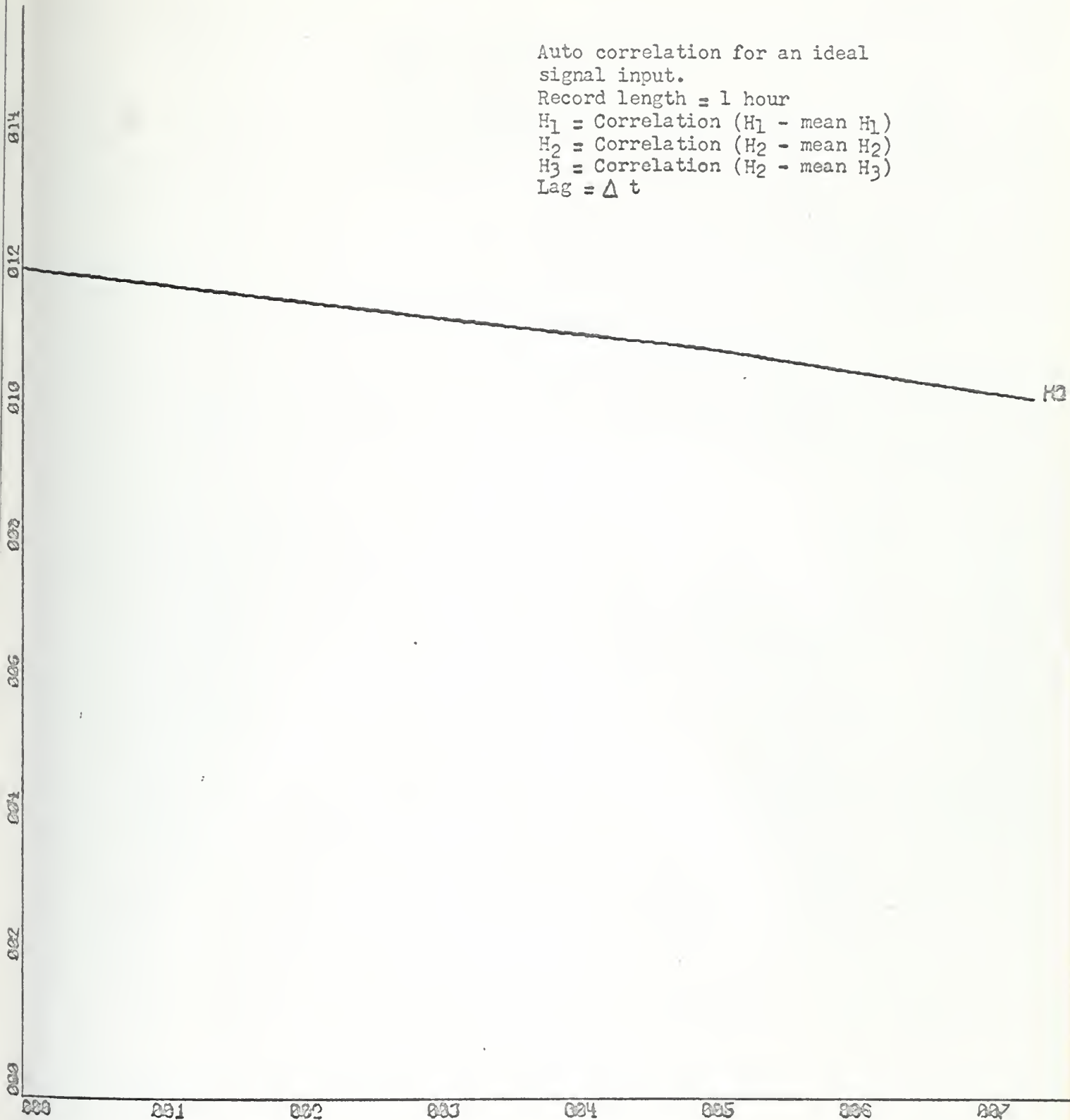

Figure 23

X-SCALE = $1.00E+01$ UNITS/INCH

Y-SCALE = $2.00E+03$ UNITS/INCH

ANDERSON BOX 263

AUTOCORRELATION FUNCTION Y IN PRODUCTS Δ IN LAGS

Cross correlation for an ideal signal input.

Record length = 1 hour

H_{12} = Correlation (H_1 - mean H_1 and H_2 - mean H_2)

H_{13} = Correlation (H_1 - mean H_1 and H_3 - mean H_3)

H_{23} = Correlation (H_2 - mean H_2 and H_3 - mean H_3)

Lag = Δt



Figure 24

X-SCALE = $1.00E+01$ UNITS/INCH

Y-SCALE = $2.00E+03$ UNITS/INCH

ANDERSON BOX 263

CROSCORRELATION FUNCTION Y IN PRODUCTS X IN LAGS

Coherence for an ideal signal input

Record length = 1 hour

H_{12} = Coherence of H_1 and H_2

H_{13} = Coherence of H_1 and H_3

H_{23} = Coherence of H_2 and H_3

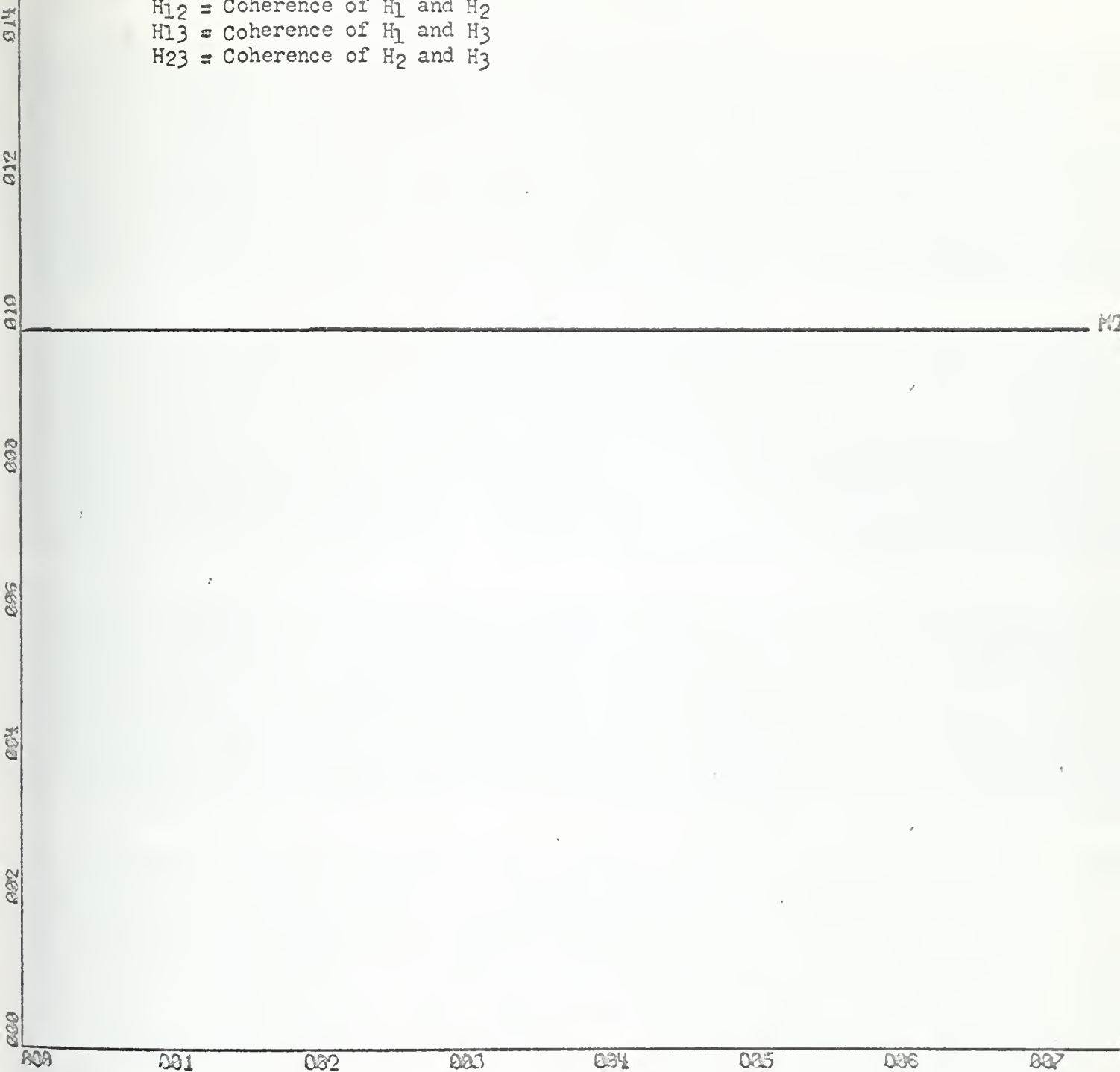

Figure 25

X-SCALE = $1.00E+01$ UNITS/INCH

Y-SCALE = $2.00E-01$ UNITS/INCH

ANDERSON BOX 263

COHERENCE

FUNCTION Y IN COH X IN LAGS

TYPICAL ANALOG PLOT OF
MAGNETIC INTENSITY VS. TIME
FILTER - RC WITH TIME CONSTANT OF 6 SECONDS

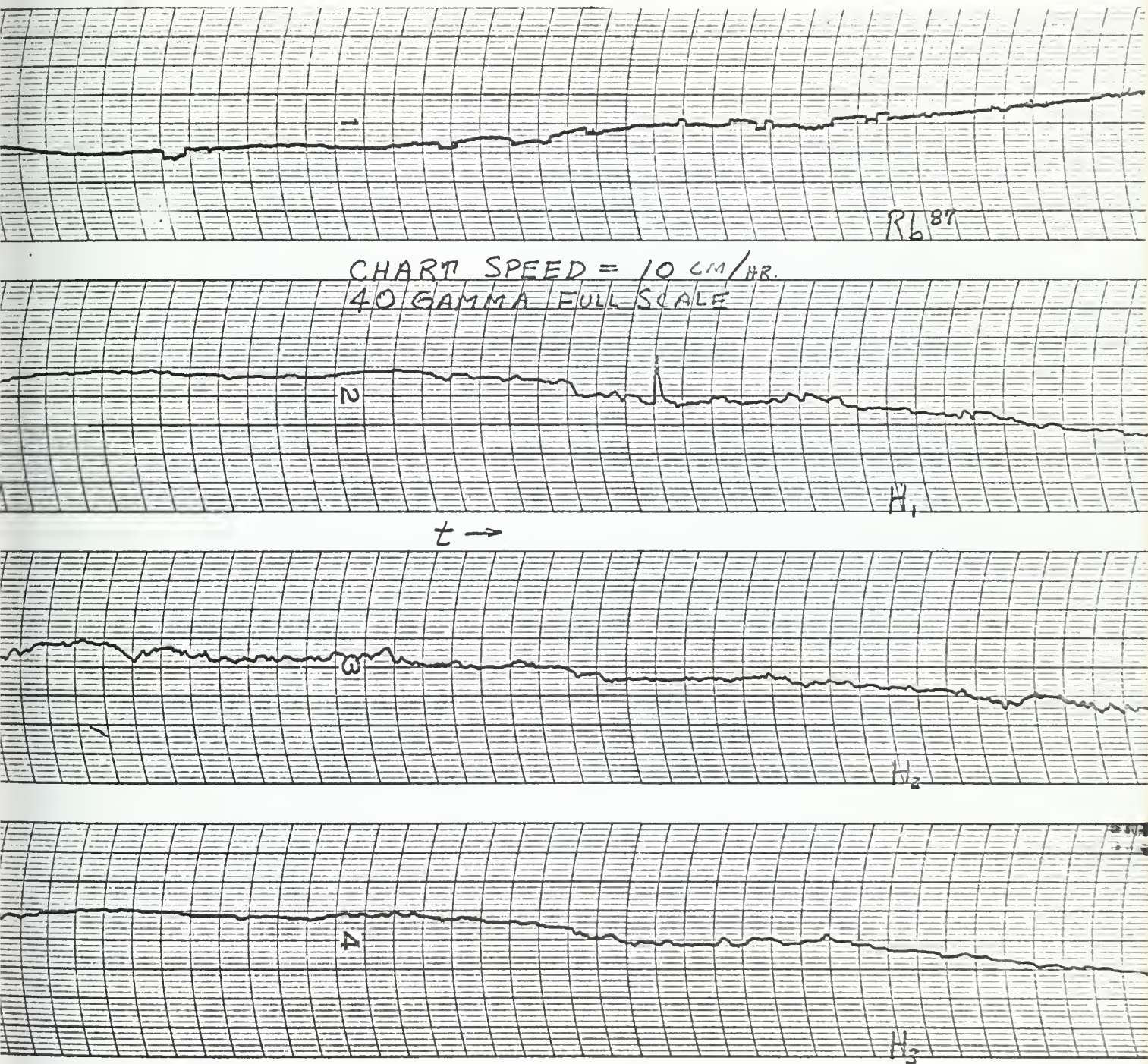

CLEVELAND, OHIO

PRINTED IN U.S.A.

+

CHART NO. RA 2941 30

BRU

FIGURE 26

TYPICAL ANALOG PLOT OF
THE DIFFERENCES VS. TIME
FILTER = RC WITH TIME CONSTANT OF 6 SECONDS

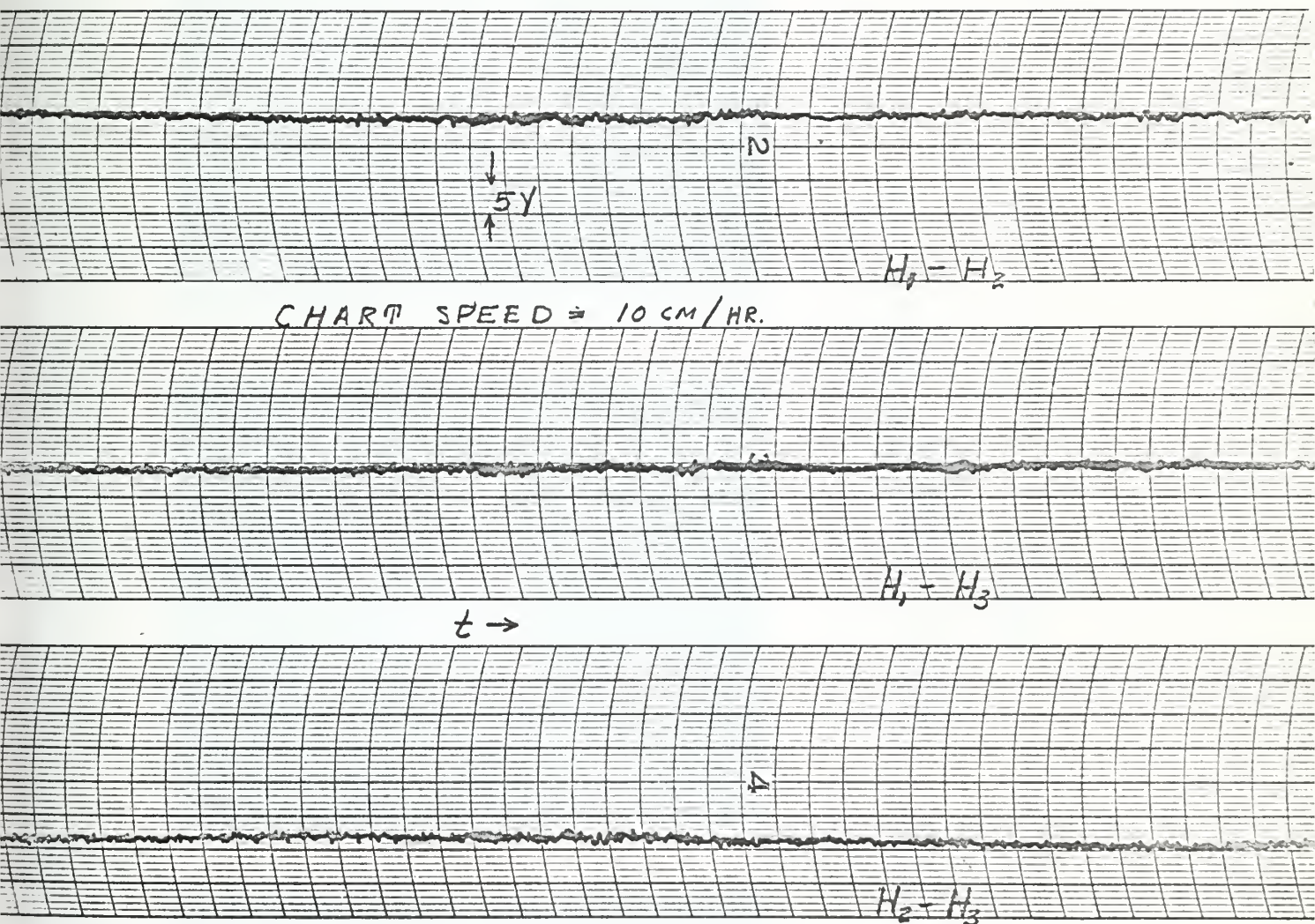

DIVISION OF CLEVITE CORPORATION

CLEVELAND, OHIO

PRINTED IN U.S.A. +

FIGURE 27

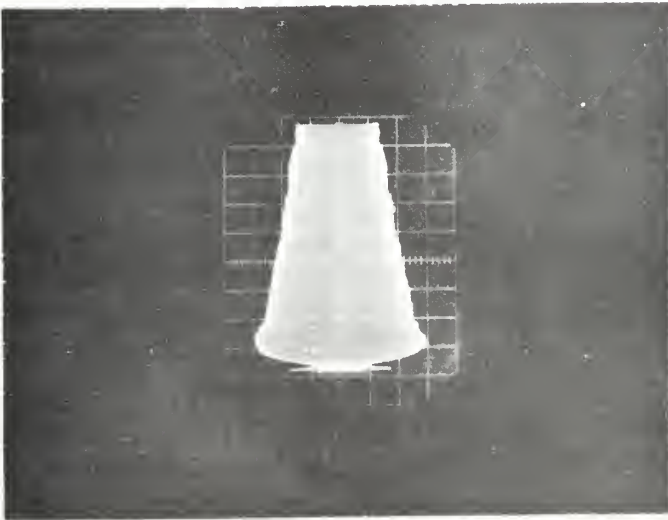

H₁

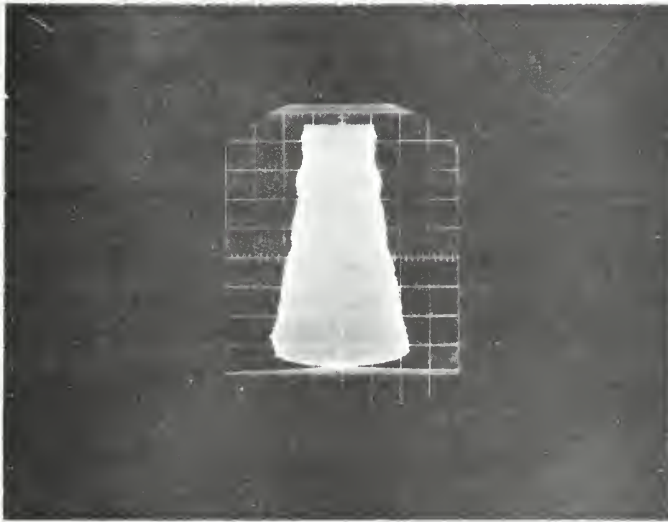

H₂

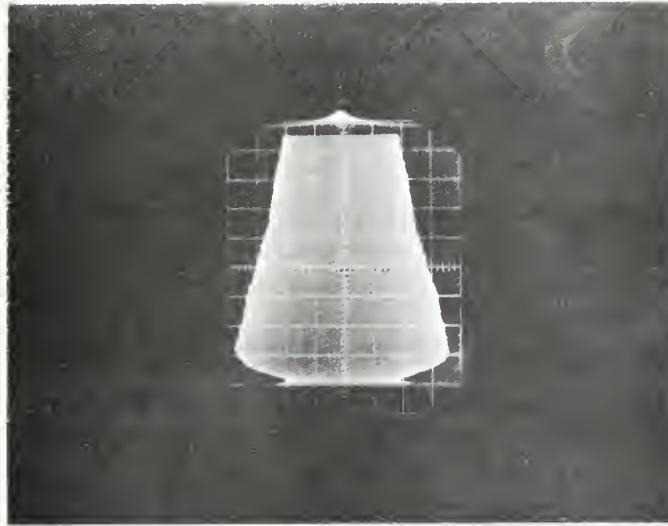

H₃

PRECESSION SIGNALS FROM THE THREE SENSORS AFTER PREFAMPLIFICATION
HORIZONTAL = 0.1 SEC/CM
VERTICAL = 0.1 VOLT/CM

FIGURE 28

4.2 Magnetic field measurements

Only representative results of the magnetic field measurements are presented, since the measurements are not complete at this time. Samples of plots made with the clock at 100 kc/s are included to illustrate the effect of the clock frequency on the results. For the associated density function of the differences, the allowable values are 0 ± 1.1 , ± 2.2 , $\pm \dots$ in gamma, with the clock at 100 kc/s. The expanded difference vs. time shows clearly the \pm last bit limitation. Comparing the density functions with the plots for the clock at 300 kc, shows that most of the noise associated with the measurement is due to the last bit and can be reduced by increasing the clock frequency. The perturbation experiments were conducted with the clock at 300 kc/s. The results of the perturbation experiments show clearly the effect of the digital filtering, and the importance of time constant consideration for target detection. The oscillator is to be run 1 mc/s for further experiments. Also, many of the errors that appear in the data were the direct result of the instrumentation tape. New tape has been purchased and should eliminate most of these errors, in future records.

As pointed out previously, the basic assumptions regarding correlation are not valid, when the noise is not stationary; however, since correlation detectors can be instrumented and may prove useful in the detection problem. Some of the correlation function plots are included to illustrate the effect of local perturbations on the functions.

5. Conclusions

For target detection, where the signals under consideration are in the $\frac{1}{2}$ gamma, or less range, it will be difficult to detect the target without resorting to sophisticated signal processing. In this range of signals, consideration should be given to other instruments; such as the Rubidium optically pumped magnetometer, whose theoretical sensitivity is 0.001 gamma, especially where the detector is stationary, and orientation is not a problem. It can be demonstrated that when using the same measurement technique as for the proton magnetometer, the instrument and processing noise will be an order of magnitude less than the theoretical limits imposed by the sensitivity of the instrument.

For signals in the $\frac{1}{2}$ to $1\frac{1}{2}$ gamma range, detection could be accomplished with analog type correlation detectors. These could be implemented with operational amplifiers.

Signals above this range could be detected with the simple differencing technique, and the associated R.C. filters.

Increasing the clock frequency and averaging the period over more than 1024 cycles would reduce the measurement noise to a smaller part of the total noise. The target signals could then be reduced by a factor of three, with no change in the instrumentation.

Full utilization of the inherently narrow line width of proton magnetometer cannot be achieved using the standard measuring technique. Other techniques have been suggested by Professor Carl I. Menneken; such as utilizing a rapid coherent polarization in a phase-lock loop arrangement. Further development work needs to be done to explore these possibilities.

BIBLIOGRAPHY

1. A. Abragam, The Principles of Nuclear Magnetism, University Press, 1961.
2. Herman Neidhart, Digital Methods of Measuring Frequencies from DC to 12,000 Mc, Beckman Instruments Publication.
3. Alexander Hoffman, Geophysical Interpretations of Power Spectral Analysis of Low Frequency Fluctuations in the Magnetotelluric Field, University of Texas, Ph.D. Thesis, 1962.
4. A. W. Green, Jr., B. H. List and J.F.P. Zengel, Theory, Measurement and Applications of Very-Low-Frequency Magnetotelluric Variations, Proceedings of the I. R. E., Vol. 50, No. 11, pp. 2347 - 2363, Nov., 1962.
5. J. A. Jacobs and K. Sinno, Occurrence Frequency of Geomagnetic Micropulsations, Journal of Geophysical Research, Vol. 65, No. 1, pp. 107 - 113, Jan., 1960.
6. Ragazzini and Franklin, Sampled Data Control Systems, McGraw Hill, 1958.

APPENDICES

APPENDIX I

RESULTS OF
MAGNETIC FIELD
AND PERTURBATION
EXPERIMENTS

APPENDIX I

Typical earth's magnetic field vs.
time for clock at 100 kc/s and no
local perturbations.

Record length = 6.5 hours

$H_1 = H_1 - \text{mean } H_1$

$H_2 = H_2 - \text{mean } H_1$

$H_3 = H_3 - \text{mean } H_1$

Filter = 18 point average

Mean $H_1 = 0.50917 E + 05$

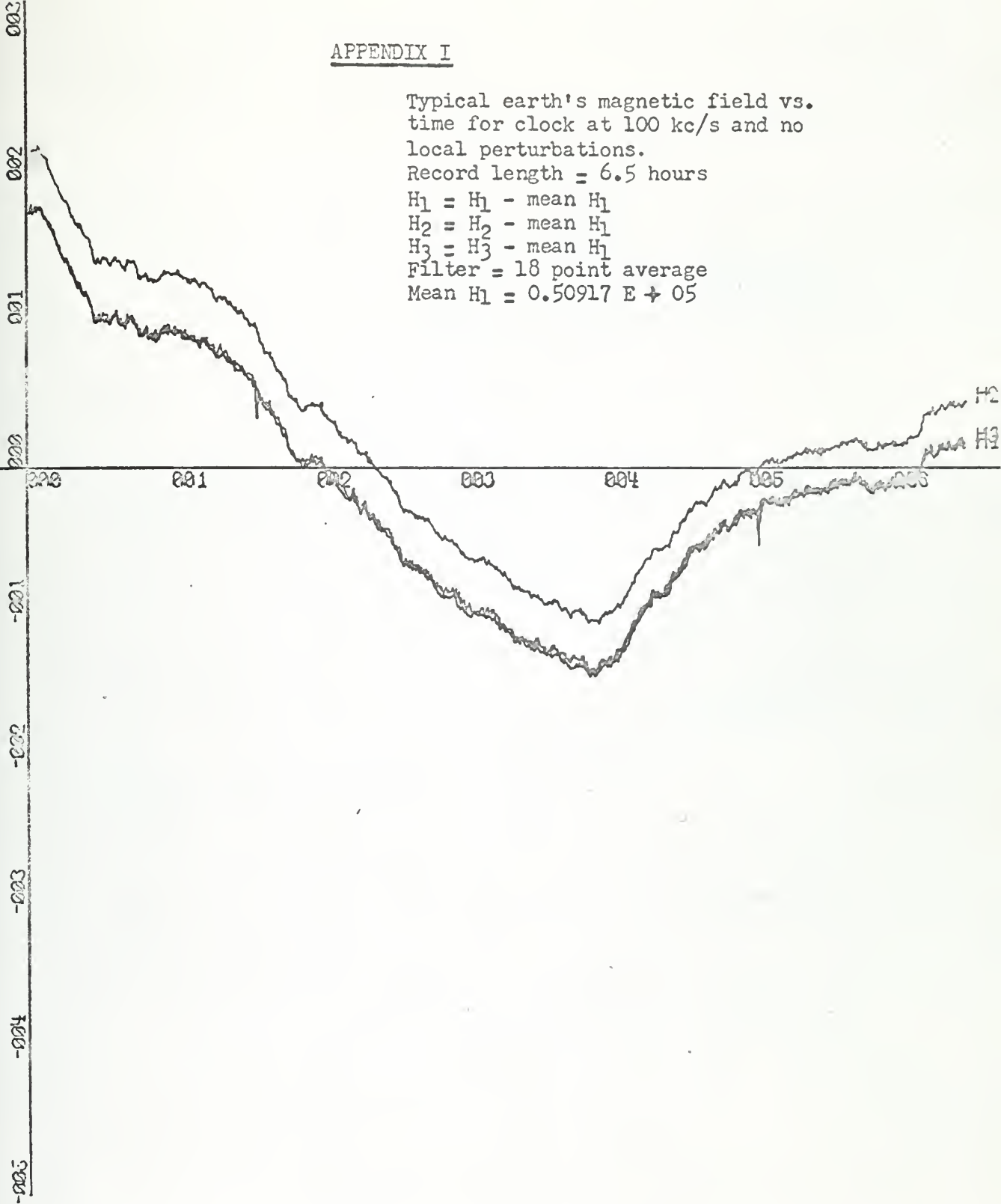

X-SCALE = 1.00E+00 UNITS/INCH.
Y-SCALE = 1.00E+01 UNITS/INCH.

ANDERSON BOX 263

EARTH'S MAGNETIC FIELD VS TIME T IN HRS H GAMMA

APPENDIX I

Typical earth's magnetic field vs. time for clock at 100 kc/s and no local perturbations.

Record length = 6.5 hours

$H_1 = H_1 - \text{mean } H_1$

$H_2 = H_2 - \text{mean } H_1$

$H_3 = H_3 - \text{mean } H_1$

Filter = Z transform low pass with time constant = 20 minutes

Mean $H_1 = 0.50917 E + 05$

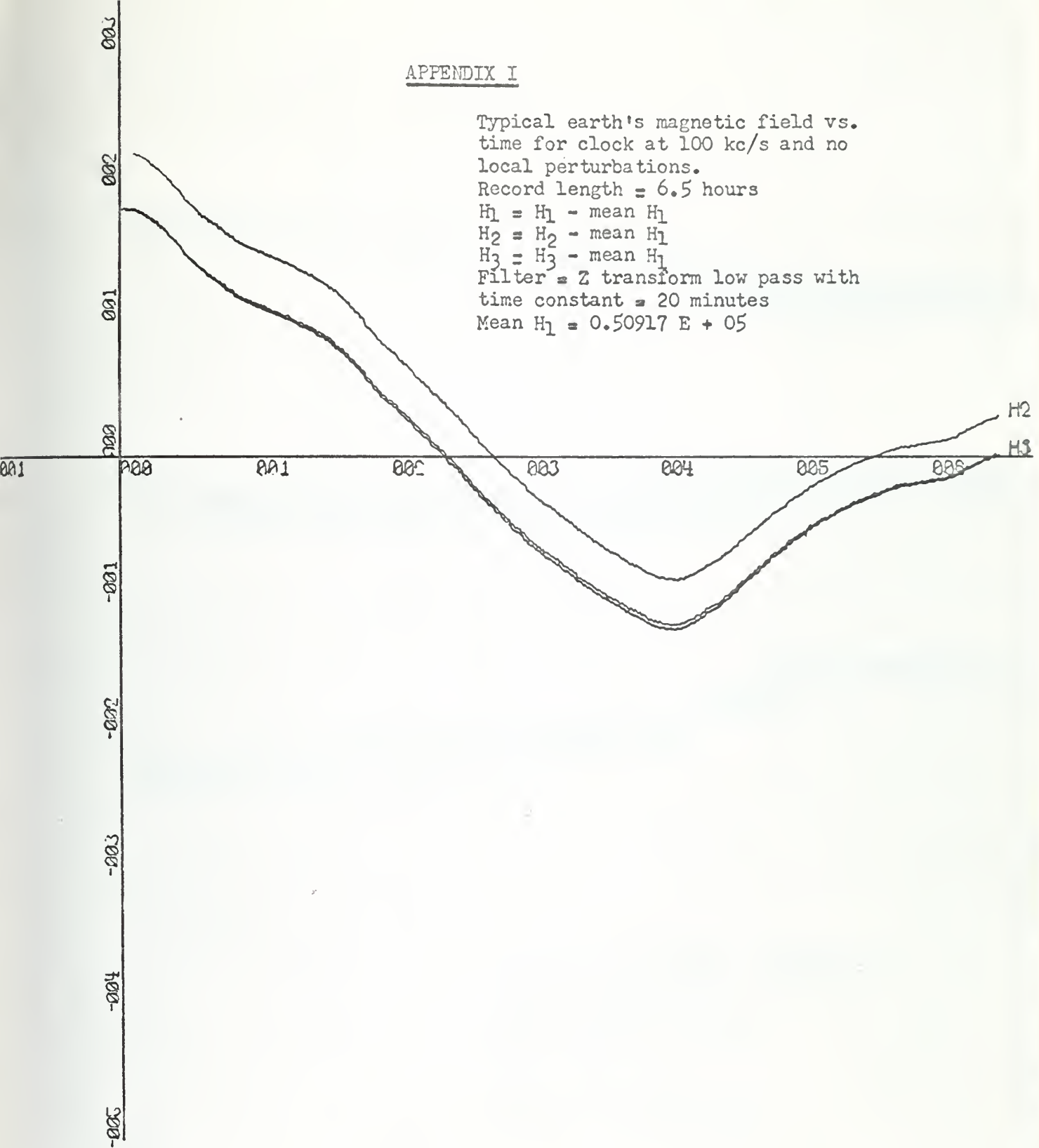

X-SCALE = 1.00E+00 UNITS/INCH

Y-SCALE = 1.00E+01 UNITS/INCH

ANDERSON FILTER
 EARTH'S MAGNETIC FIELD VS TIME T IN HRS H GAMMA

APPENDIX I

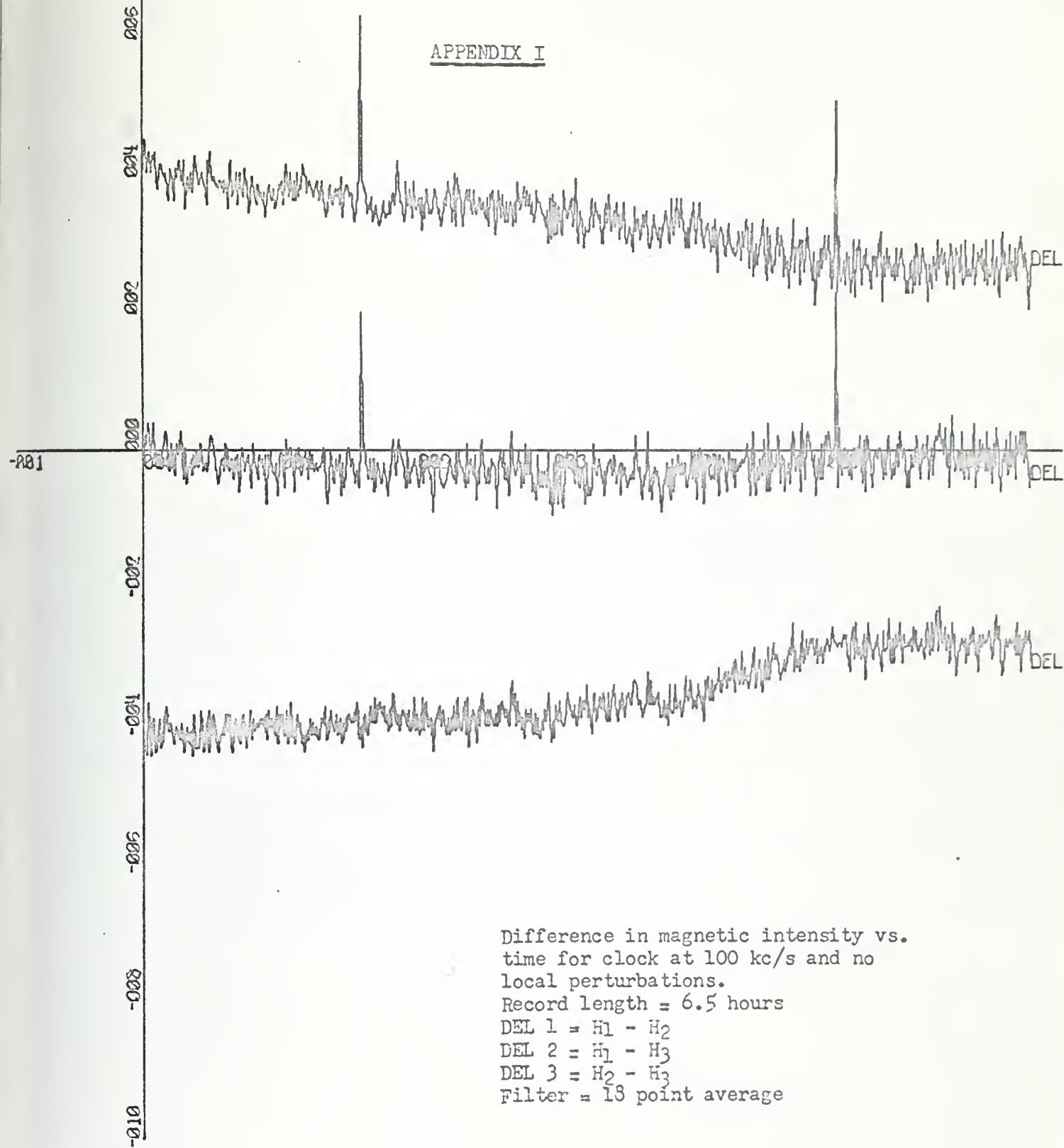

Difference in magnetic intensity vs.
time for clock at 100 kc/s and no
local perturbations.
Record length = 6.5 hours
DEL 1 = $H_1 - H_2$
DEL 2 = $H_1 - H_3$
DEL 3 = $H_2 - H_3$
Filter = 13 point average

X-SCALE = $1.00E+00$ UNITS/INCH.

Y-SCALE = $2.00E+00$ UNITS/INCH.

ANDERSON BOX 263

FIRST DIFFERENCE IN MAG FIELD T IN HRS H GAMMA

APPENDIX I

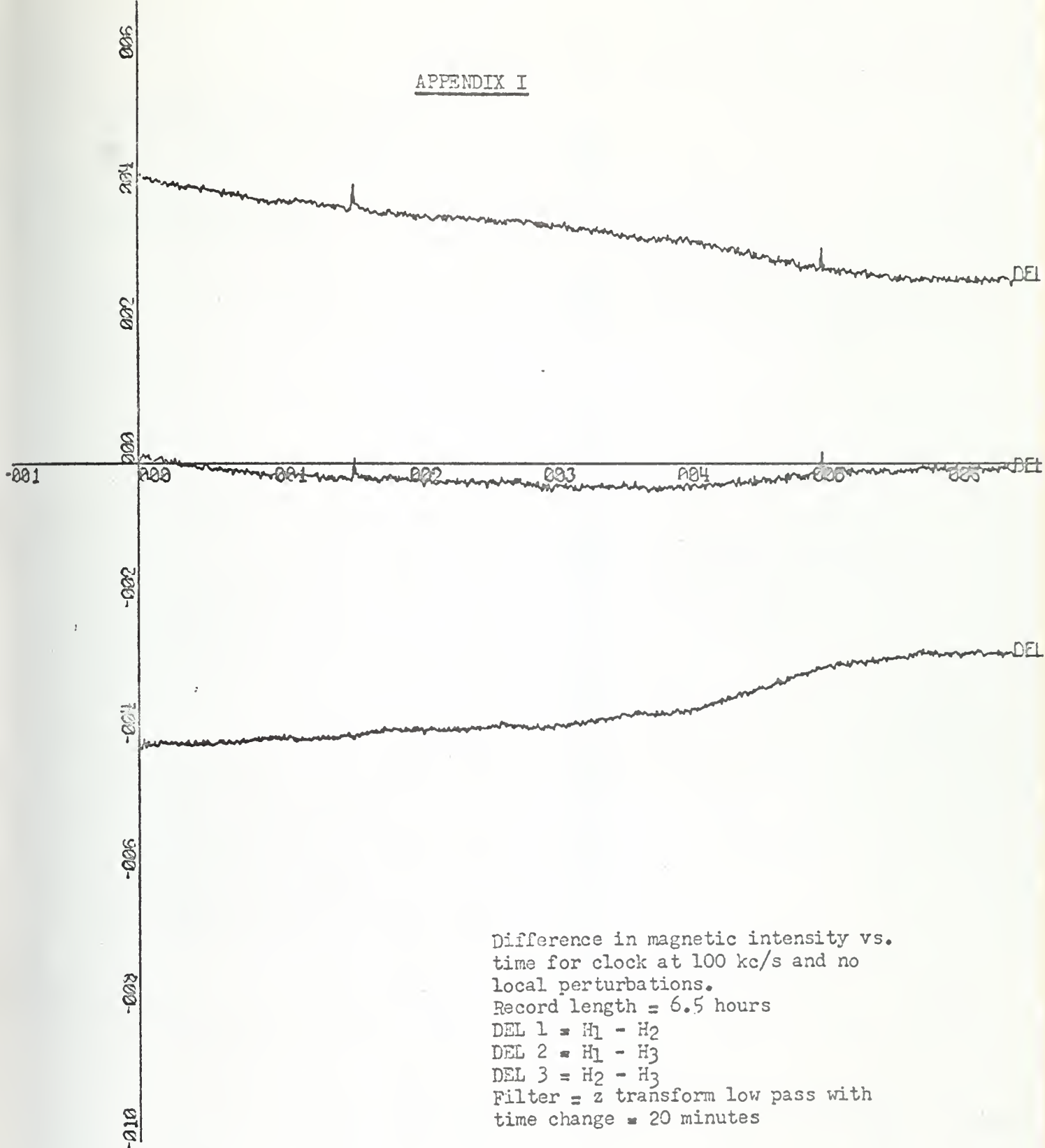

Difference in magnetic intensity vs.
time for clock at 100 kc/s and no
local perturbations.
Record length = 6.5 hours
DEL 1 = $H_1 - H_2$
DEL 2 = $H_1 - H_3$
DEL 3 = $H_2 - H_3$
Filter = z transform low pass with
time change = 20 minutes

X-SCALE = 1.00E+00 UNITS/INCH.
Y-SCALE = 2.00E+00 UNITS/INCH.

ANDERSON FILTER
FILTERED DIFFERENCE IN MAG FIELD T IN HRS H GAMMA

APPENDIX I

Normalized density function of the
difference, D. No local perturbations
Record length = 6.5 hours
Clock = 100 kc/s
 $(H_1 - H_2) - \text{mean}(H_1 - H_2) = D$
Mean = -3.21 gamma

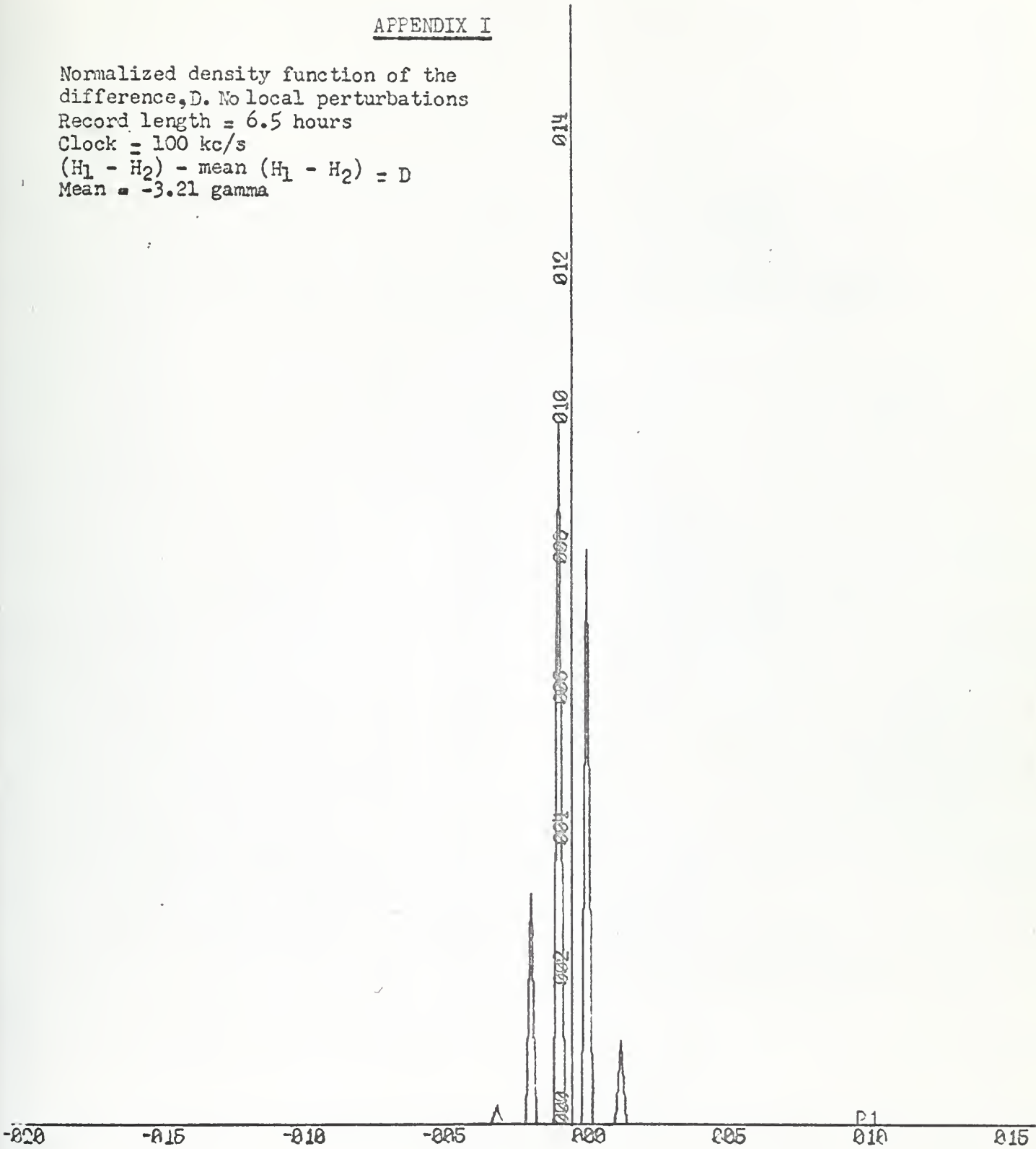

Y-SCALE = $5.00E+00$ UNITS/INCH

X-SCALE = $1.00E-01$ UNITS/INCH

ANDERSON BOX 263

DENSITY FUNCTION X IN GAMMA Y IN FREQ

APPENDIX I

Normalized density function of the
difference, D. No local perturbations
Record length = 6.5 hours
Clock = 100 kc/s
 $(H_2 - H_3) - \text{mean } (H_2 - H_3) = D$
Mean = -0.05 gamma

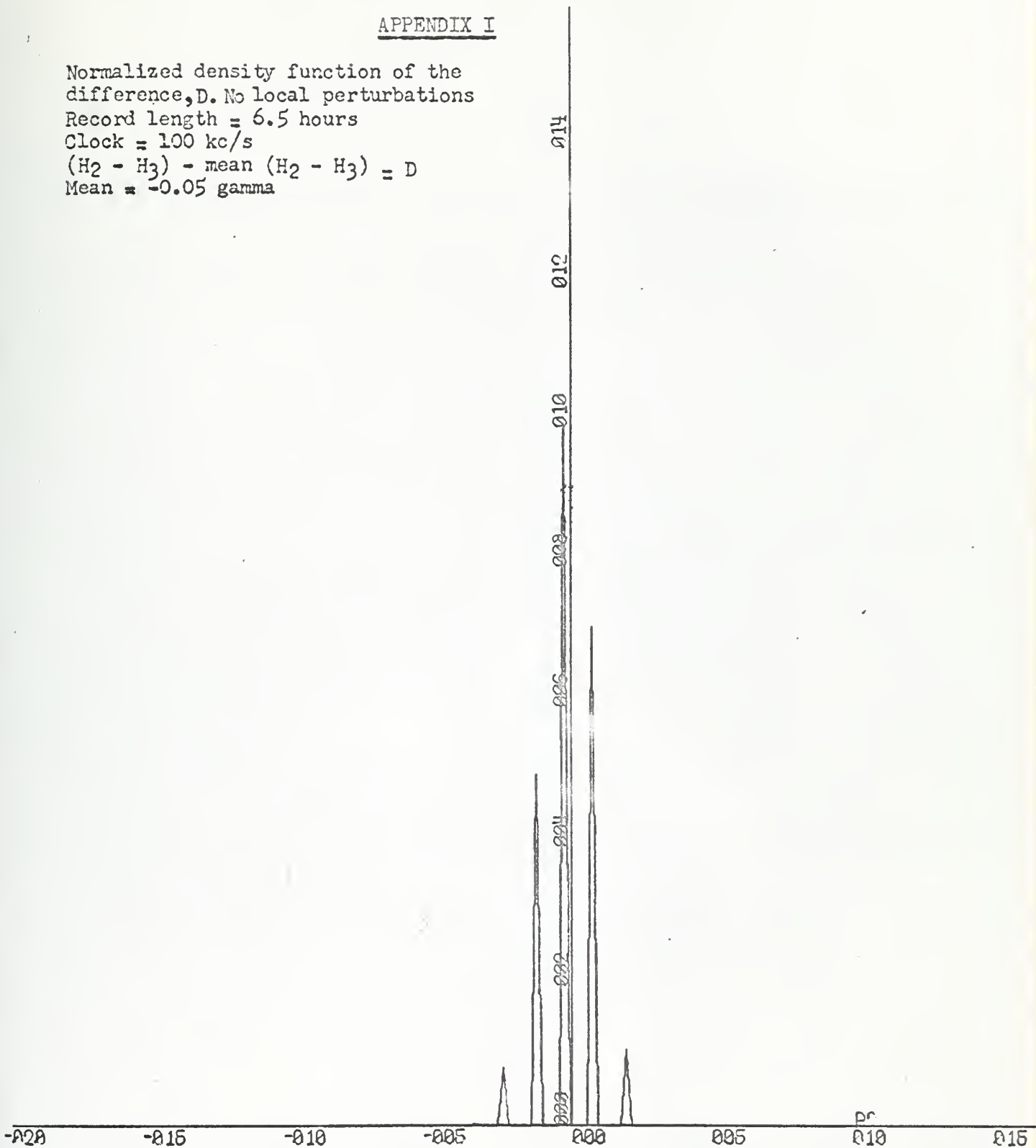

X-SCALE = 5.00E+00 UNITS/INCH.

Y-SCALE = 2.00E-01 UNITS/INCH.

ANDERSON BOX 263

DENSITY FUNCTION X IN GAMMA Y IN FREQ

APPENDIX I

Normalized density function of the
difference, D. No local perturbations

Record length = 6.5 hours

Clock = 100 kc/s

$(H_1 - H_3) - \text{mean}(H_1 - H_3) = D$

Mean = 3.16 gamma

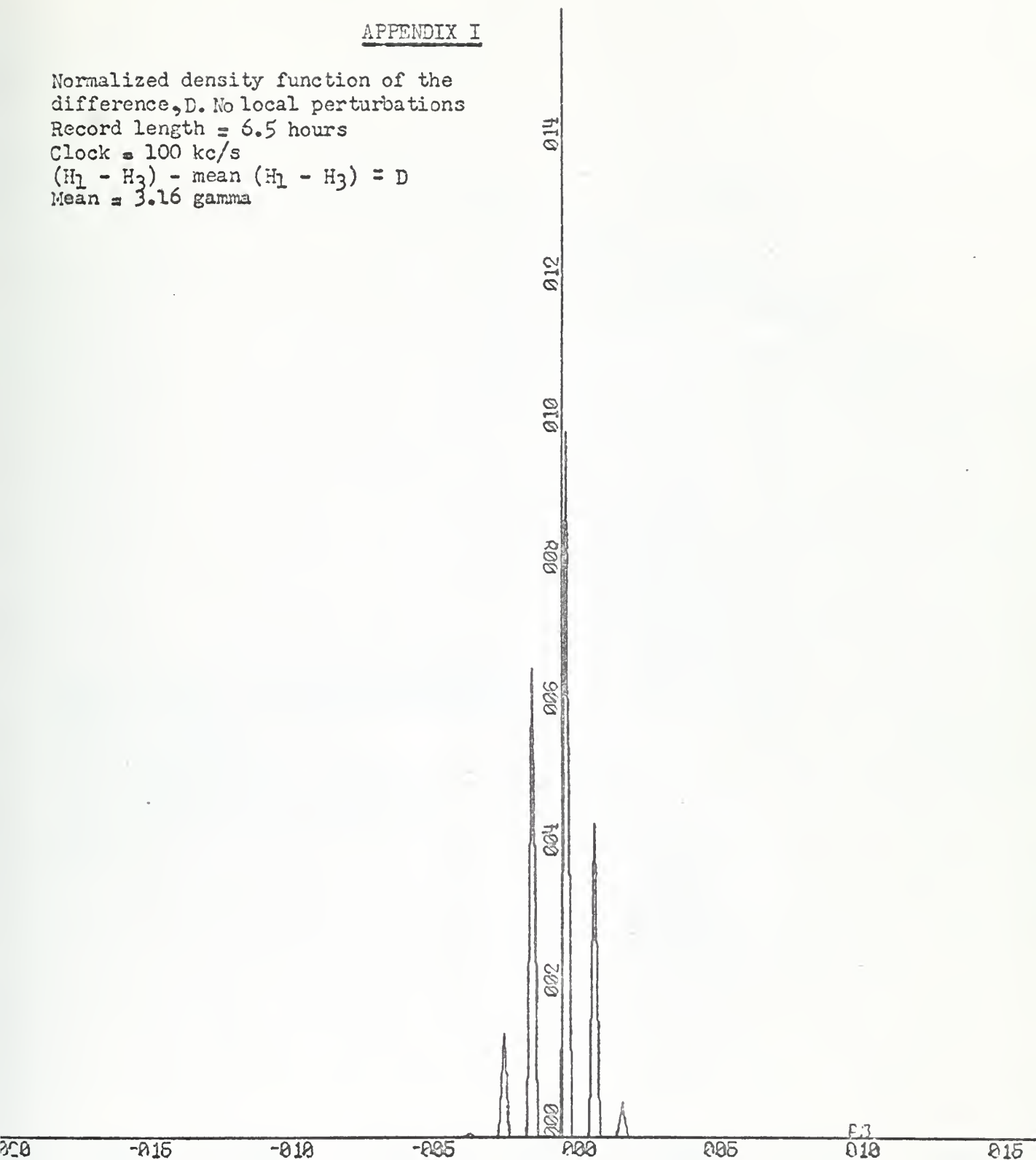

X-SCALE = 5.00E+00 UNITS/INCH.

Y-SCALE = 2.00E-01 UNITS/INCH.

ANDERSON BOX 263

DENSITY FUNCTION X IN GAMMA Y IN FREQ

APPENDIX I

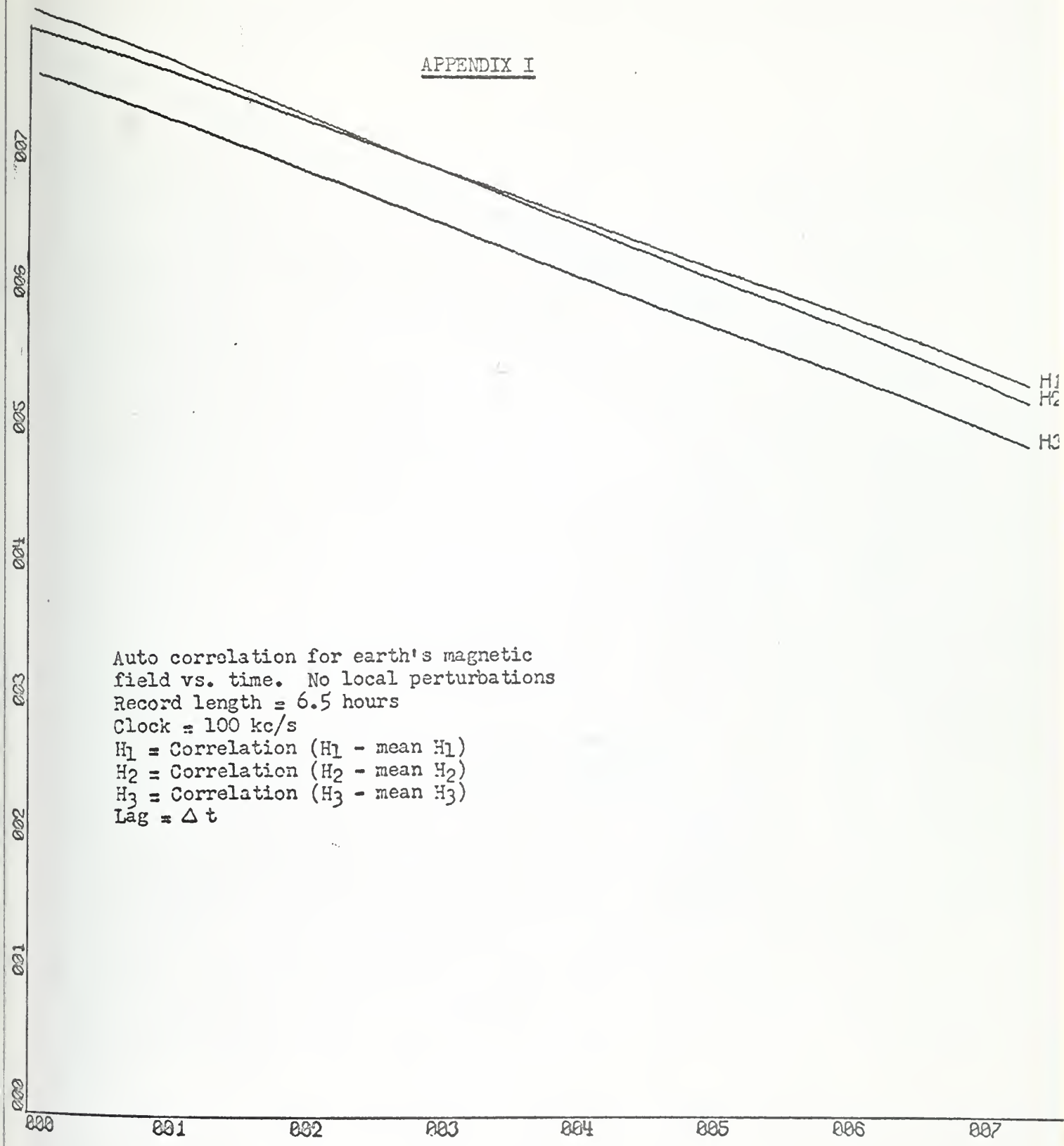

X-SCALE = 1.00E+01 UNITS/INCH.

Y-SCALE = 1.00E+01 UNITS/INCH.

ANDERSON BOX 263

AUTOCORRELATION FUNCTION Y IN PRODUCTS X IN LAGS

APPENDIX I

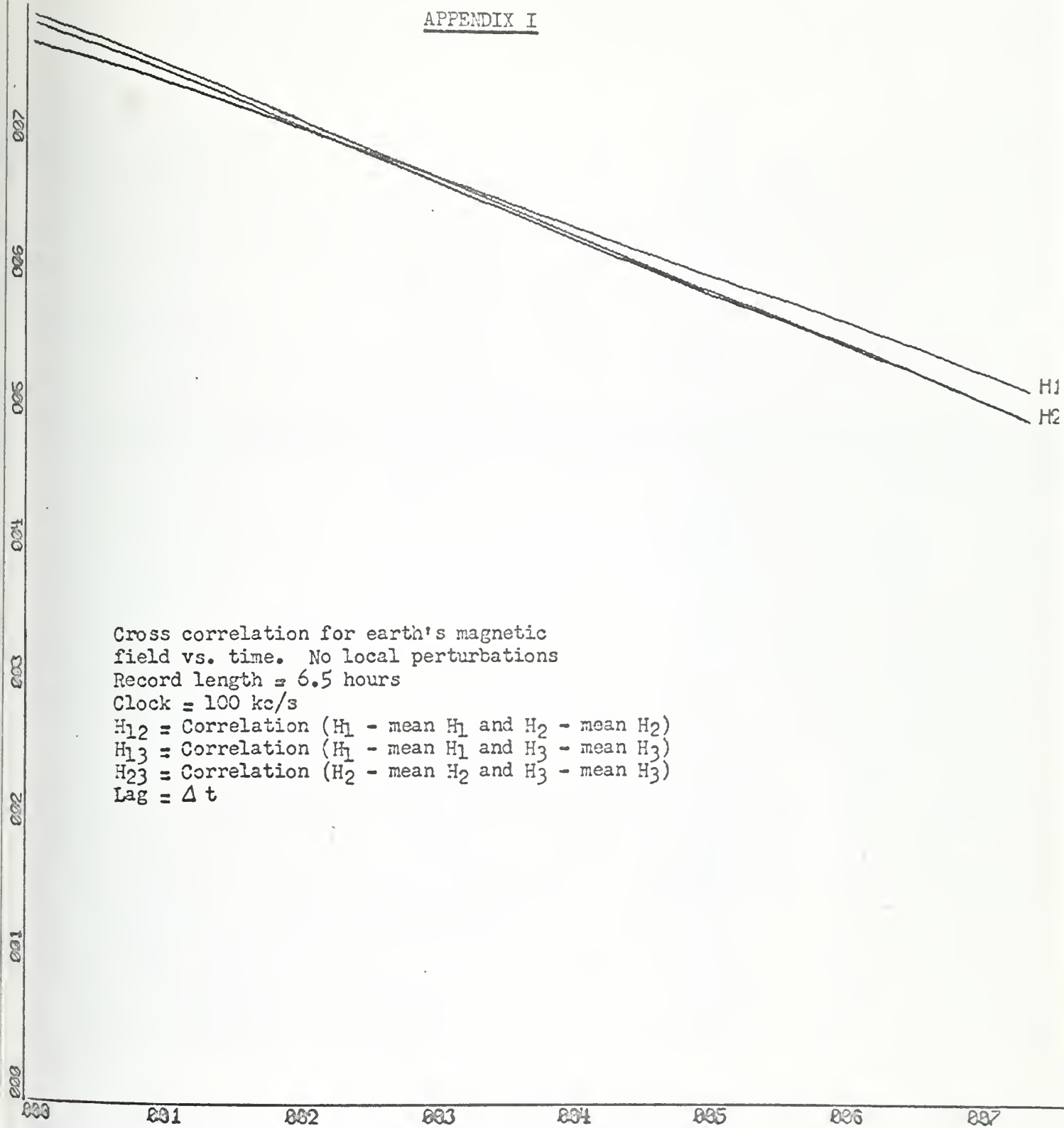

X-SCALE = 1.00E+01 UNITS/INCH.

Y-SCALE = 1.00E+01 UNITS/INCH.

ANDERSON BOX 263

CROSCORRELATION FUNCTION Y IN PRODUCTS X IN LAGS

APPENDIX I

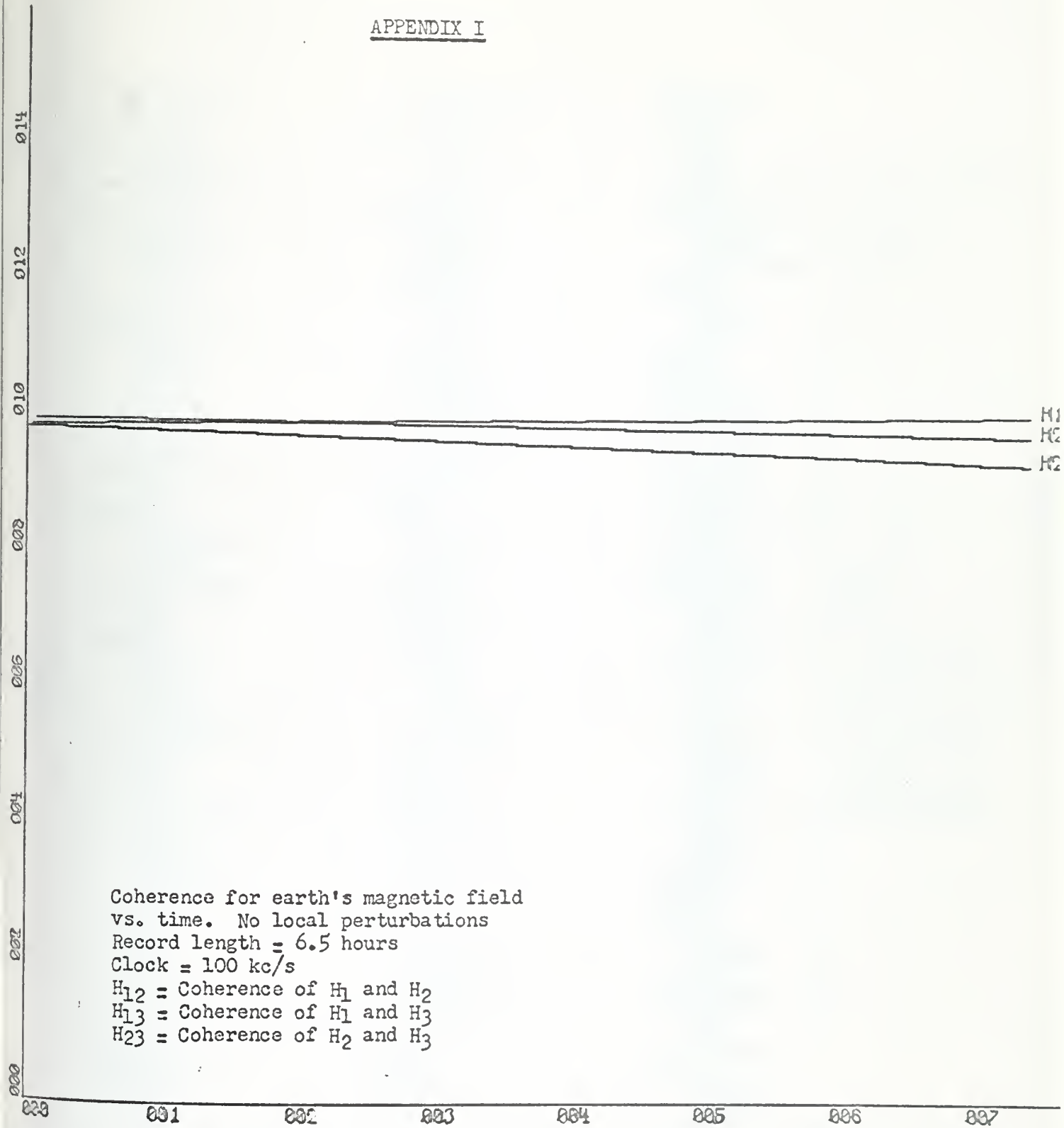

X-SCALE = 1.00E+01 UNITS/INCH

Y-SCALE = 2.00E-01 UNITS/INCH

ANDERSON BOX 263

COHERENCE

FUNCTION Y IN COH X IN LAGS

APPENDIX I



Differences in magnetic intensity with no local perturbations.

- Record length = 1 hour
- Filter = 2 point average
- Clock = 100 kc/5
- DEL 1 = H1 - H2
- DEL 2 = H1 - H3
- DEL 3 = H2 - H3

APPENDIX I



Differences in magnetic intensity with no local perturbations.

- Record length = 1 hour
- Filter = Z transform low pass
with time constant of 100 seconds
- Clock = 100 kc/s
- DEL 1 = H₁ - H₂
- DEL 2 = H₁ - H₃
- DEL 3 = H₂ - H₃

APPENDIX I

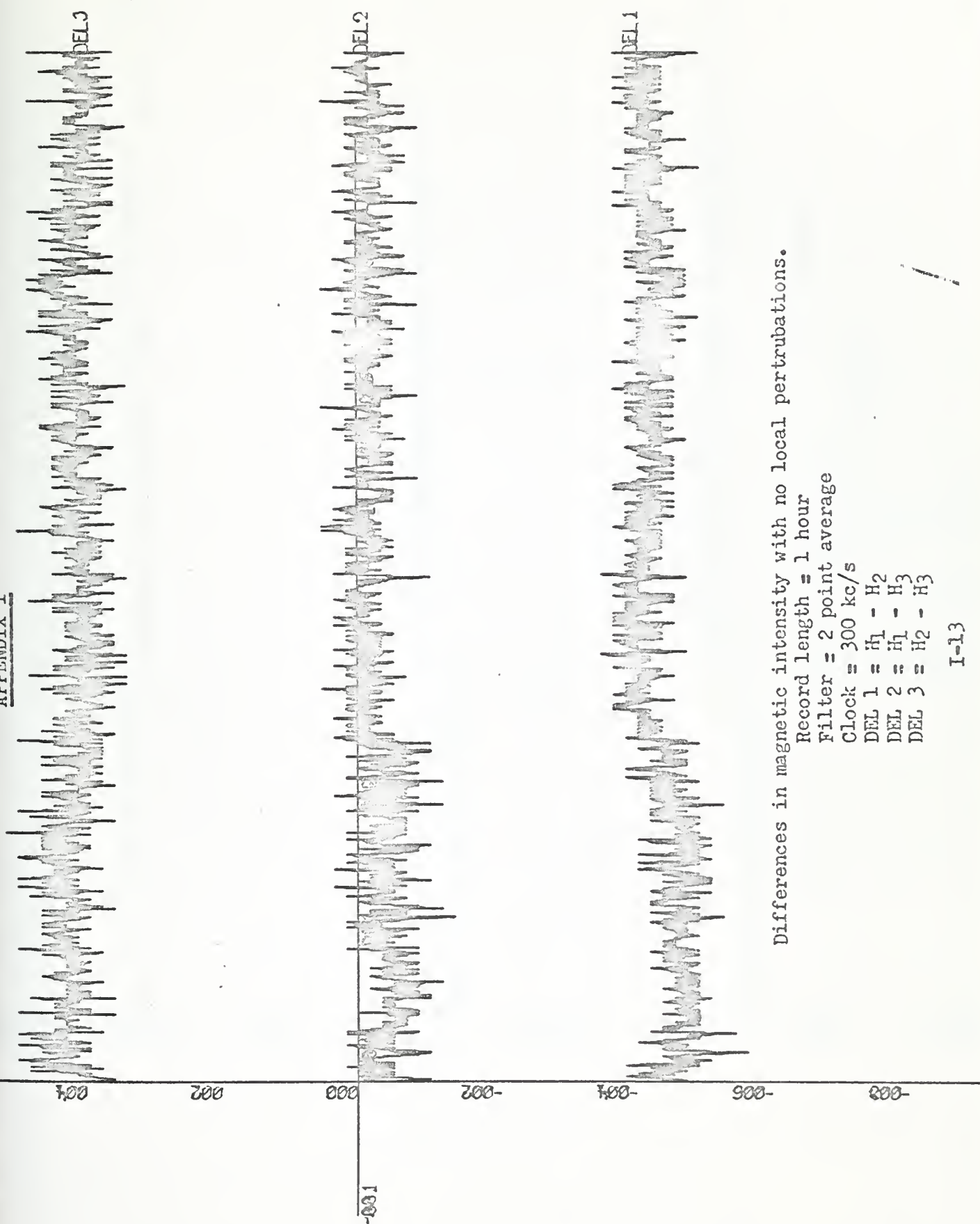

Differences in magnetic intensity with no local perturbations.

- Record length = 1 hour
- Filter = 2 point average
- Clock = 300 kc/s
- DEL 1 = $f_1 - H_2$
- DEL 2 = $f_1 - H_3$
- DEL 3 = $H_2 - H_3$

APPENDIX I



Differences in magnetic intensity with no local perturbations.

Record length = 1 hour

Filter = Z transform low pass
with time constant of 100 seconds

Clock = 300 kc/s

DEL 1 = H₁ - H₂

DEL 2 = H₁ - H₃

DEL 3 = H₂ - H₃

APPENDIX I

Typical earth's magnetic field vs.
time for clock at 300 kc/s and no
local perturbations.

Record length = 6.5 hours

$H_1 = H_1 - \text{mean } H_1$

$H_2 = H_2 - \text{mean } H_1$

$H_3 = H_3 - \text{mean } H_1$

Filter = 18 point average

Mean $H_1 = 0.50961 E + 05$

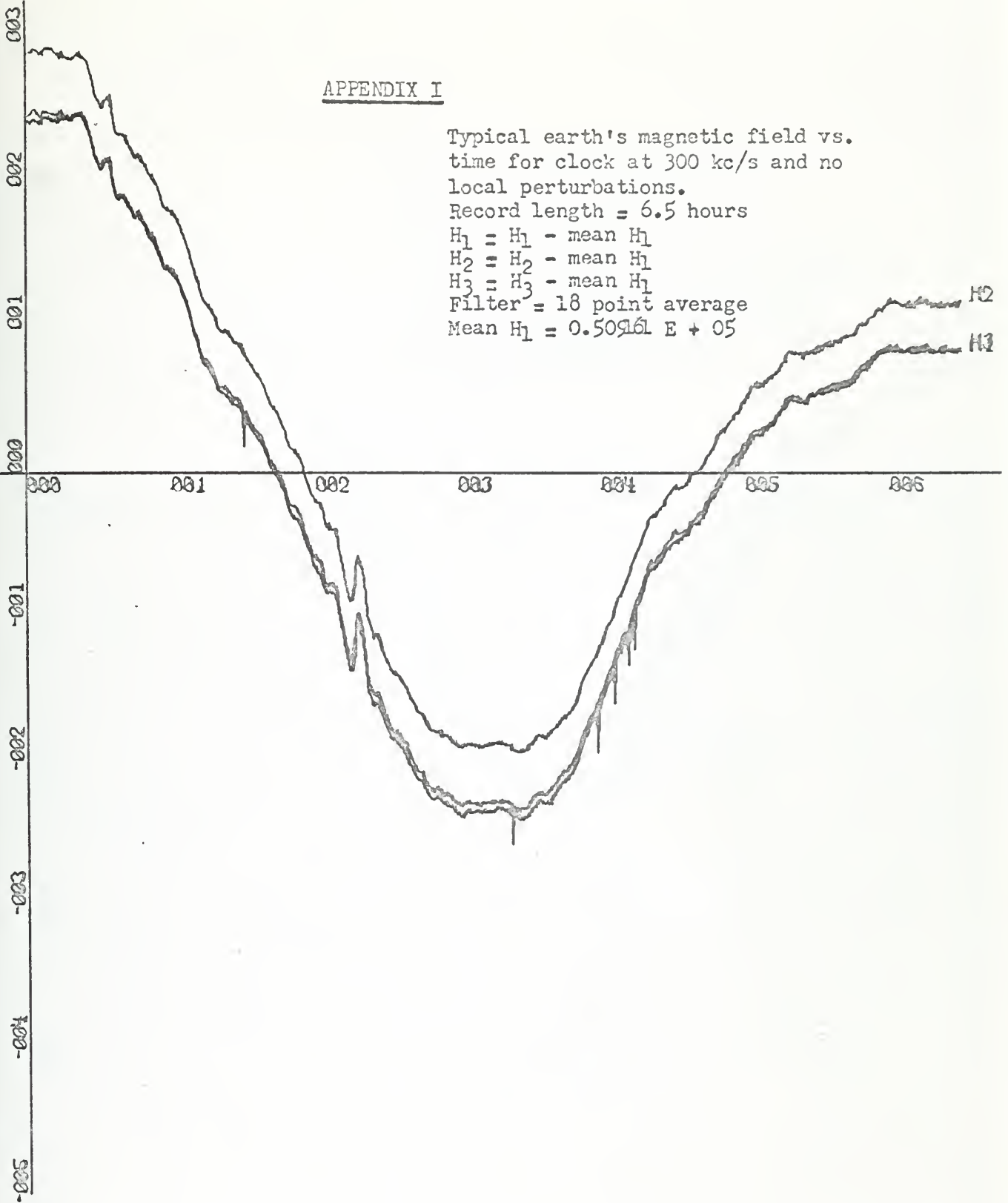

X-SCALE = $1.00E+00$ UNITS/INCH.

Y-SCALE = $1.00E+01$ UNITS/INCH.

ANDERSON BOX 263

EARTH'S MAGNETIC FIELD VS TIME T IN HRS H GAMMA

APPENDIX I

Typical earth's magnetic field vs. time for clock at 300 kc/s and no local perturbations.

Record length = 6.5 hours

$H_1 = H_1 - \text{mean } H_1$

$H_2 = H_2 - \text{mean } H_1$

$H_3 = H_3 - \text{mean } H_1$

Filter = Z transform low pass with time constant = 20 minutes

Mean $H_1 = 0.509161 E + 05$

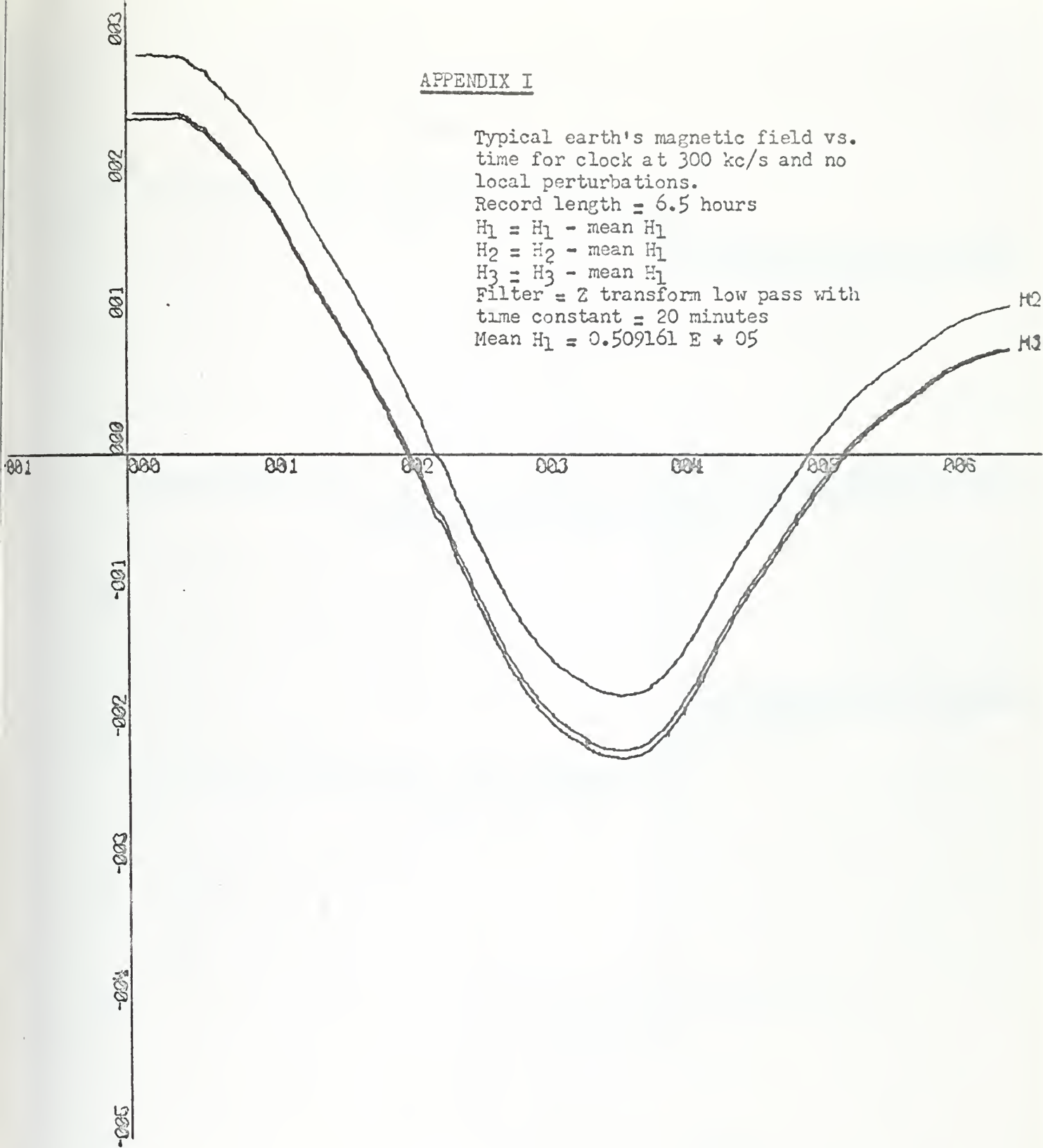

X-SCALE = $1.00E+00$ UNITS/INCH.

Y-SCALE = $1.00E+01$ UNITS/INCH.

ANDERSON FILTER

EARTH'S MAGNETIC FIELD VS TIME T IN HRS H GAMMA

APPENDIX I

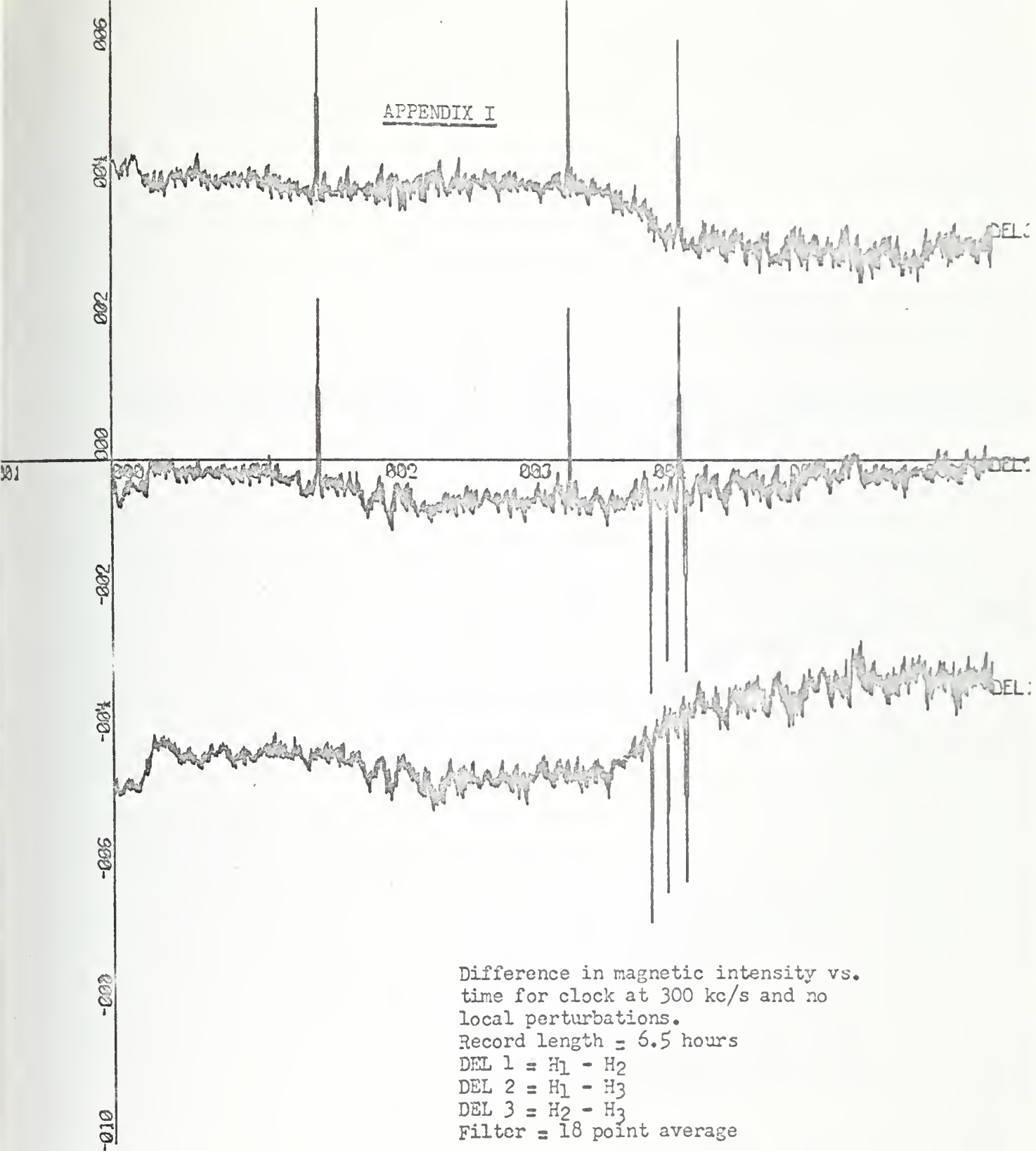

X-SCALE = $1.00E+00$ UNITS/INCH.

Y-SCALE = $2.00E+00$ UNITS/INCH.

ANDERSON BOX 263

FIRST DIFFERENCE IN MAG FIELD

T IN HRS H GAMMA

APPENDIX I

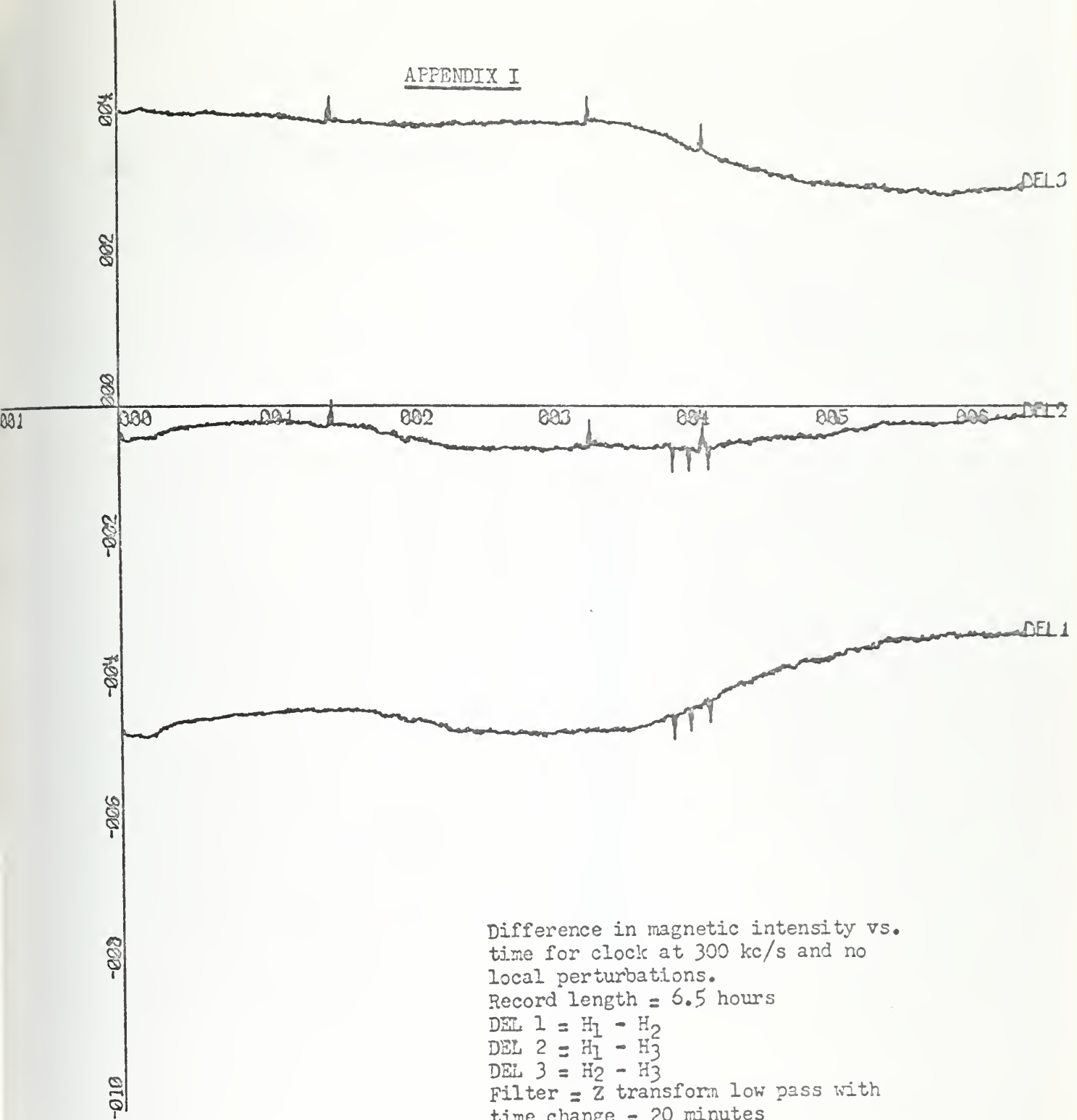

X-SCALE = 1.00E+00 UNITS/INCH

Y-SCALE = 2.00E+00 UNITS/INCH

ANDERSON FILTER
FILTERED DIFFERENCE IN MAG FIELD T IN HRS H GAMMA

APPENDIX I

Normalized density function of the
difference, D. No local perturbations
Record length = 6.5 hours
Clock = 300 kc/s
 $(H_1 - H_2) - \text{mean}(H_1 - H_2) = D$
Mean = -4.09 gamma

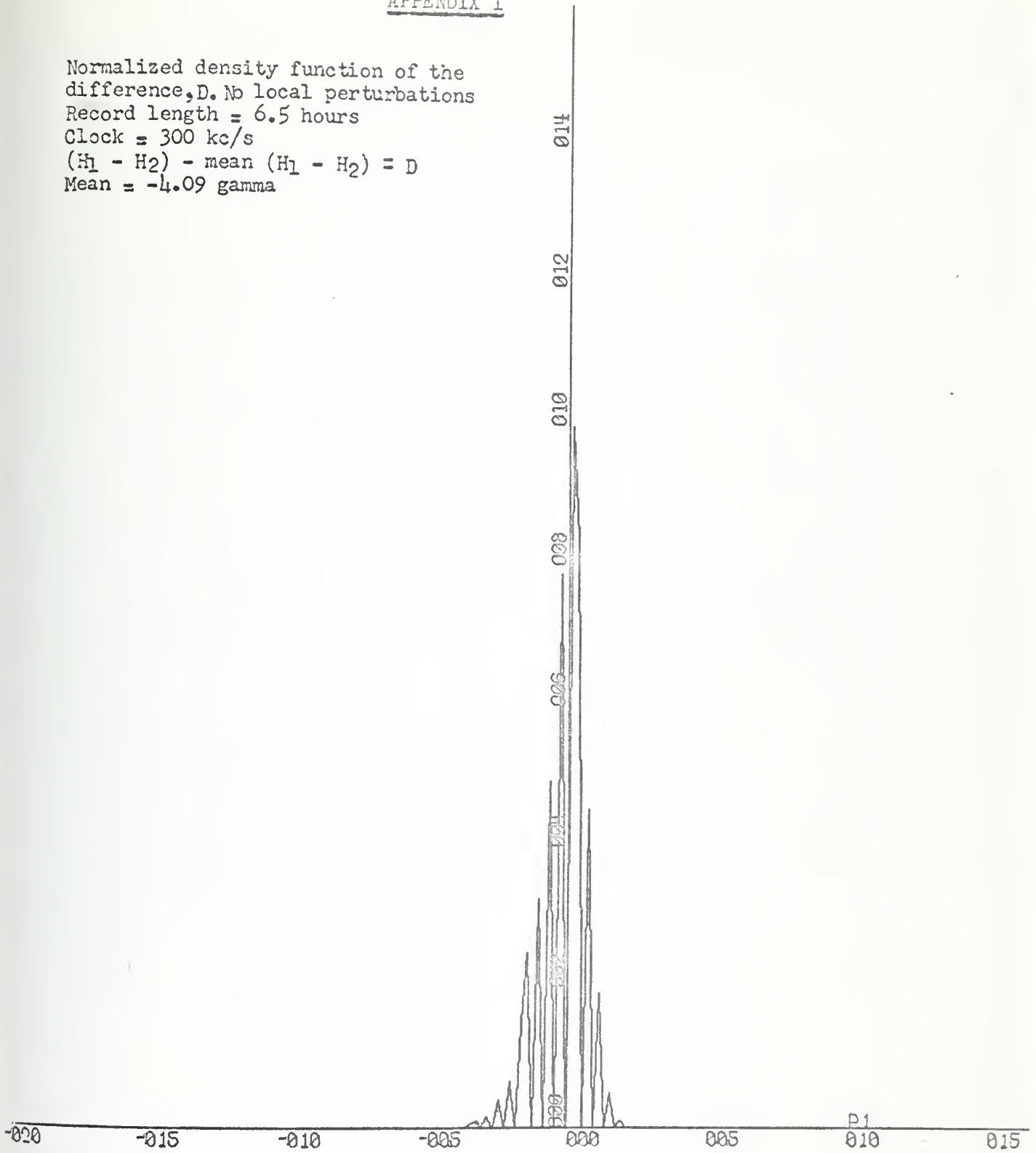

X-SCALE = 5.00E+00 UNITS/INCH.

Y-SCALE = 2.00E-01 UNITS/INCH.

ANDERSON BOX 263

DENSITY FUNCTION X IN GAMMA Y IN FREQ

APPENDIX I

Normalized density function of the
difference, D. No local perturbations
Record length = 6.5 hours
Clock = 300 kc/s
 $(H_2 - H_3) - \text{mean}(H_2 - H_3) = D$
Mean = -0.38 gamma

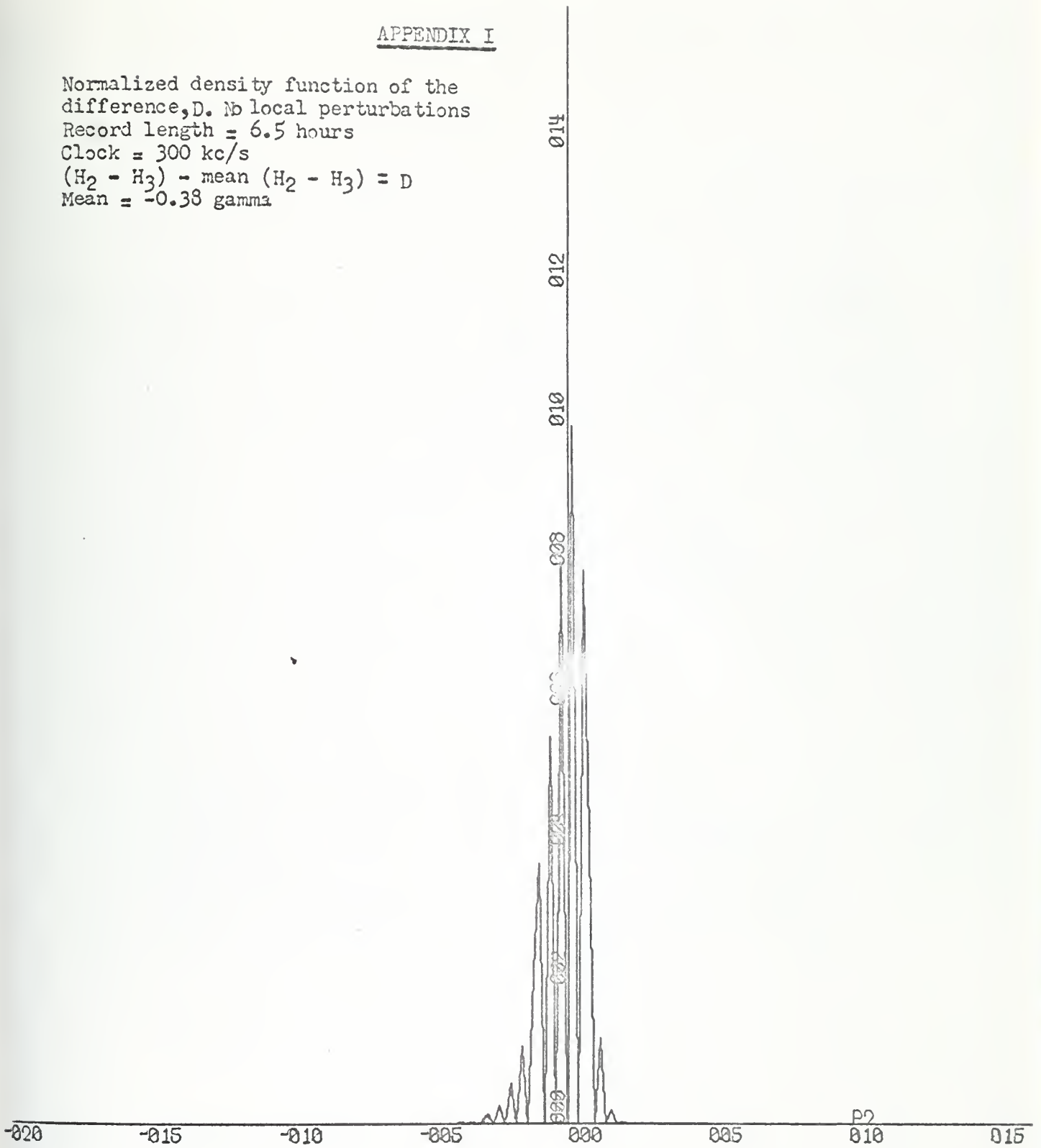

X-SCALE = 5.00E+00 UNITS/INCH

Y-SCALE = 2.00E-01 UNITS/INCH

ANDERSON BOX 263

DENSITY FUNCTION X IN GAMMA Y IN FREQ

APPENDIX I

Normalized density function of the
difference, D. No local perturbations
Record length = 6.5 hours
Clock = 300 kc/s
 $(H_1 - H_3) - \text{mean } (H_1 - H_3) = D$
Mean = 3.70 gamma

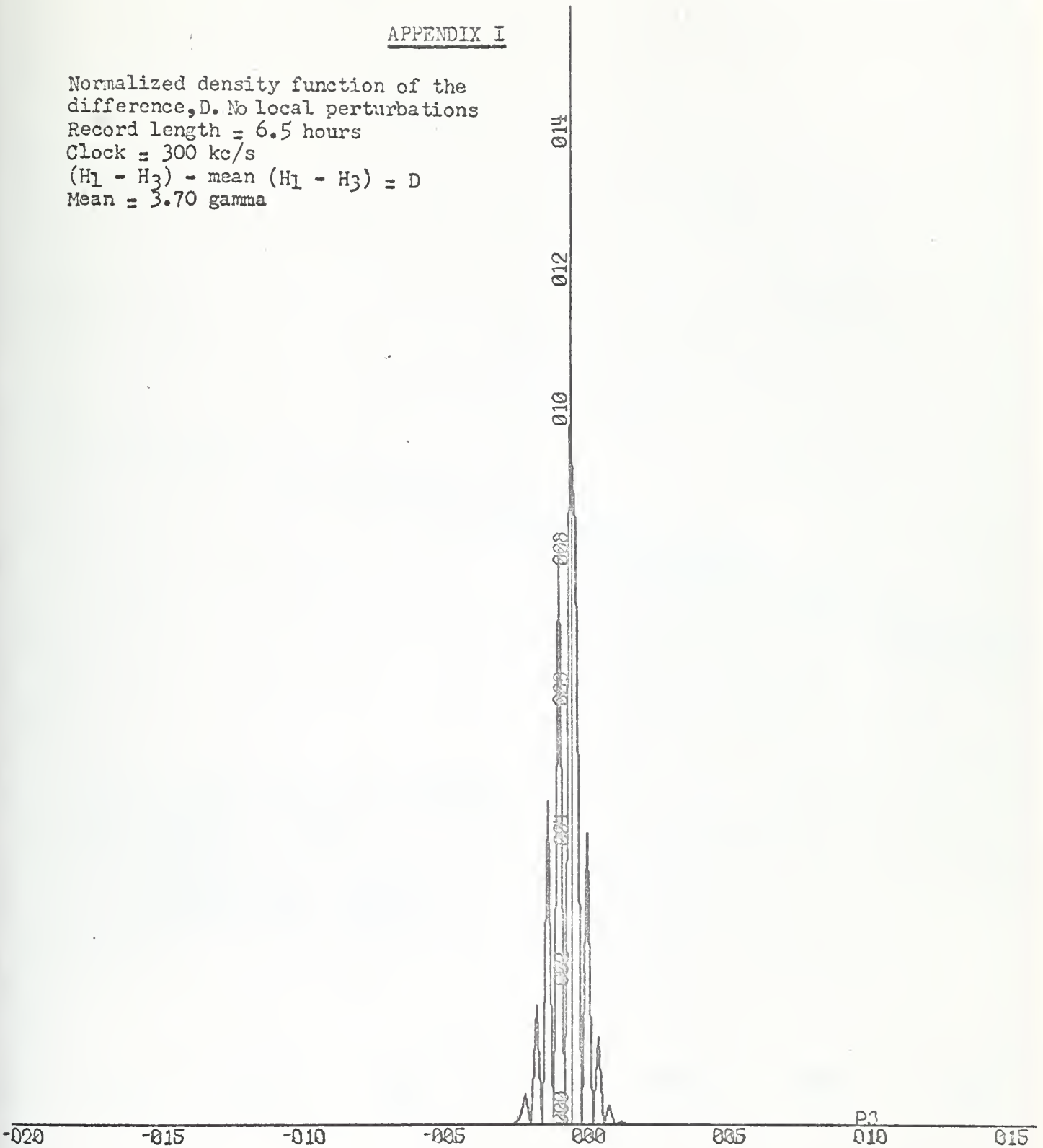

X-SCALE = 5.00E+00 UNITS/INCH.

Y-SCALE = 2.00E-01 UNITS/INCH.

ANDERSON BOX 263

DENSITY FUNCTION X IN GAMMA Y IN FREQ

APPENDIX I

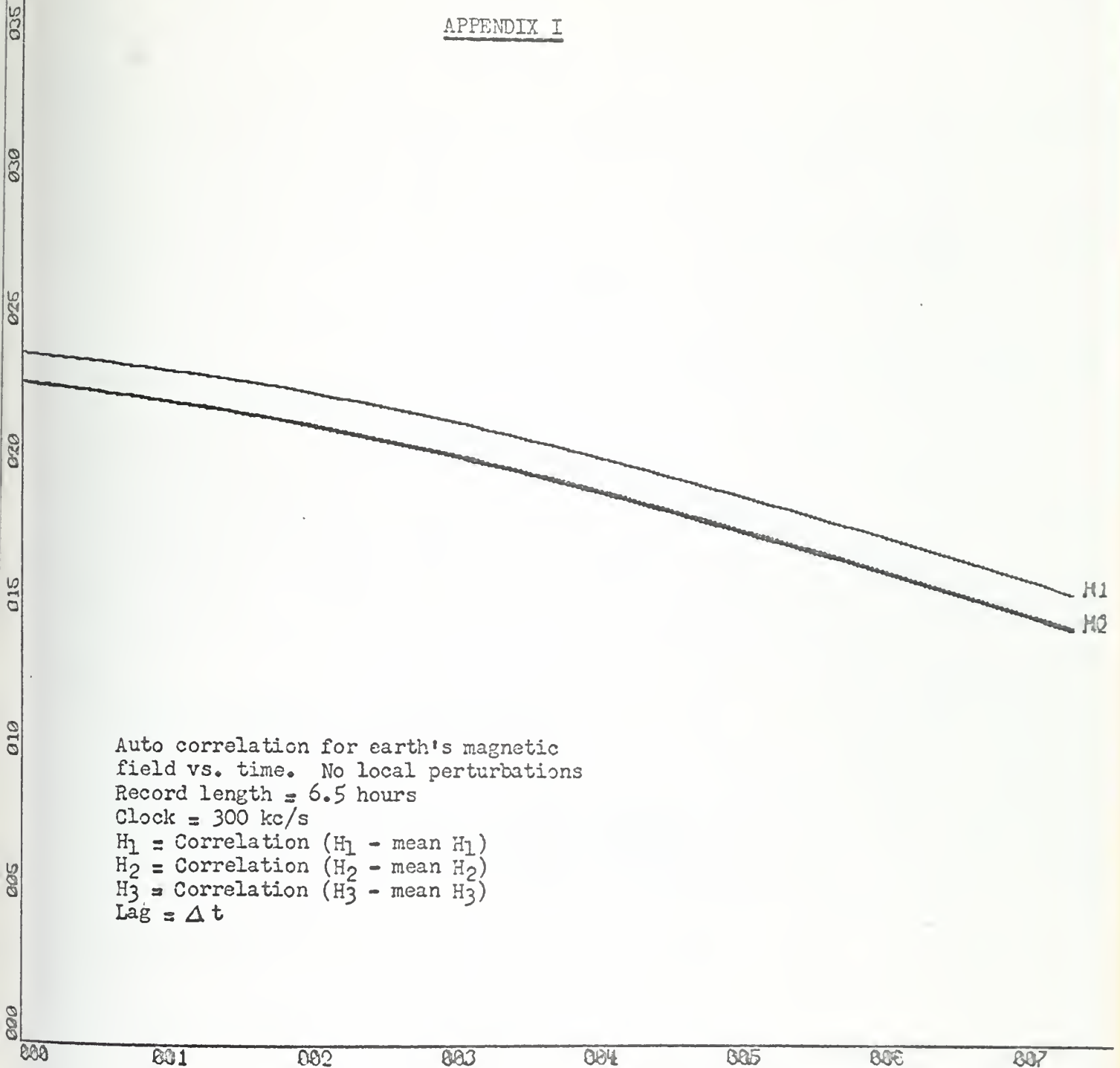

X-SCALE = 1.00E+01 UNITS/INCH.

Y-SCALE = 5.00E+01 UNITS/INCH.

ANDERSON BOX 263

AUTOCORRELATION FUNCTION Y IN PRODUCTS X IN LAGS

APPENDIX I

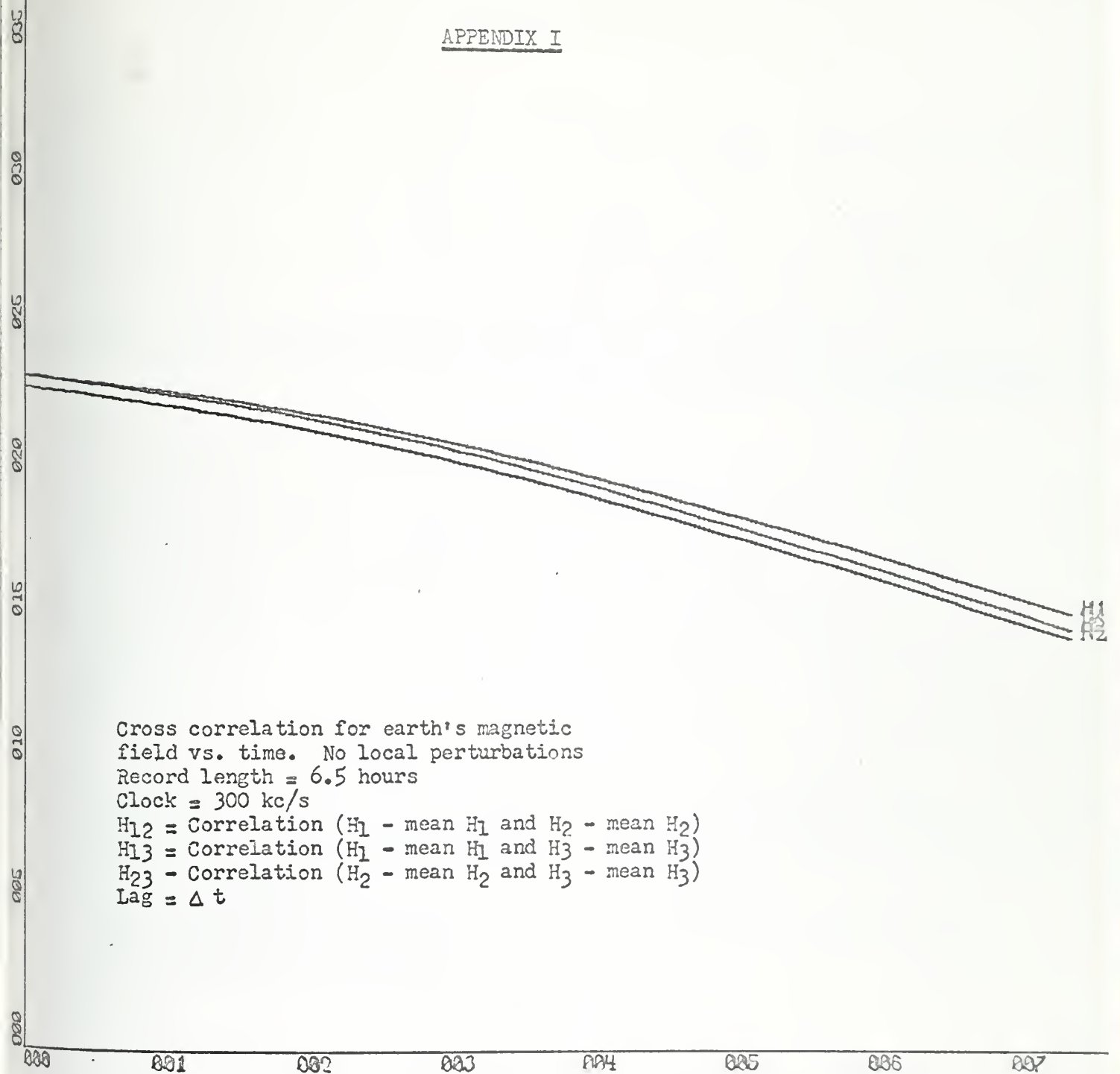

X-SCALE = 1.00E+01 UNITS/INCH

Y-SCALE = 5.00E+01 UNITS/INCH

ANDERSON BOX 263

CROSCORRELATION FUNCTION Y IN PRODUCTS X IN LAGS

APPENDIX I

Coherence for earth's magnetic field

vs. time. No local perturbations

Record length = 6.5 hours

Clock = 300 kc/s

H₁₂ = Coherence of H₁ and H₂

H₁₃ = Coherence of H₁ and H₃

H₂₃ = Coherence of H₂ and H₃

000 001 002 003 004 005 006 007

X-SCALE = 1.00E+01 UNITS/INCH

Y-SCALE = 2.00E-01 UNITS/INCH

ANDERSON BOX 263

COHERENCE

FUNCTION Y IN COH X IN LAGS

APPENDIX I

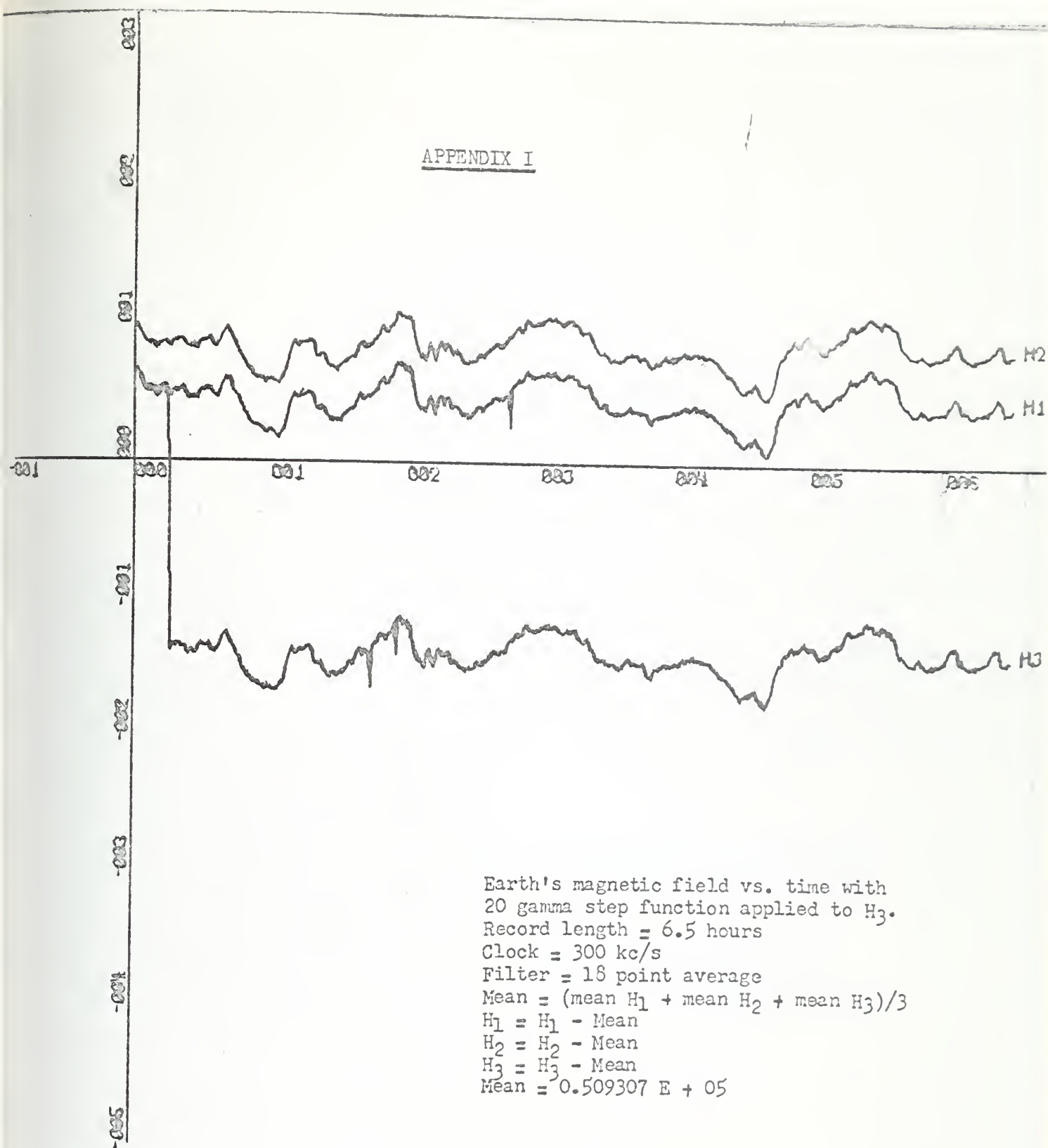

X-SCALE = 1.00E+00 UNITS/INCH

Y-SCALE = 1.00E+01 UNITS/INCH

ANDERSON BOX 263

EARTH'S MAGNETIC FIELD VS TIME T IN HRS H GAMMA

APPENDIX I

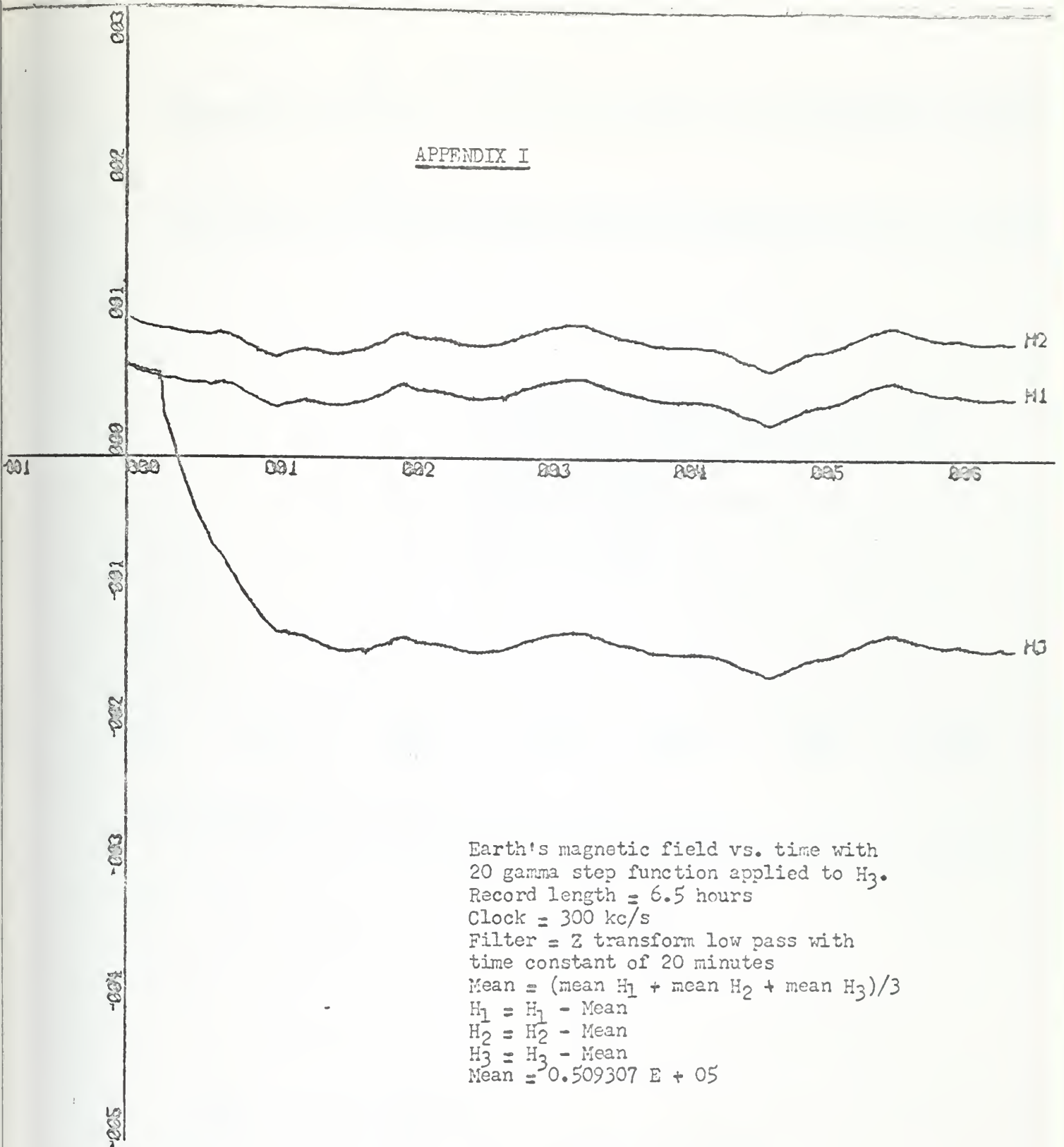

X-SCALE = 1.00E+00 UNITS/INCH

Y-SCALE = 1.00E+01 UNITS/INCH

ANDERSON FILTER

EARTH'S MAGNETIC FIELD VS TIME T IN HRS H GAMMA

APPENDIX I

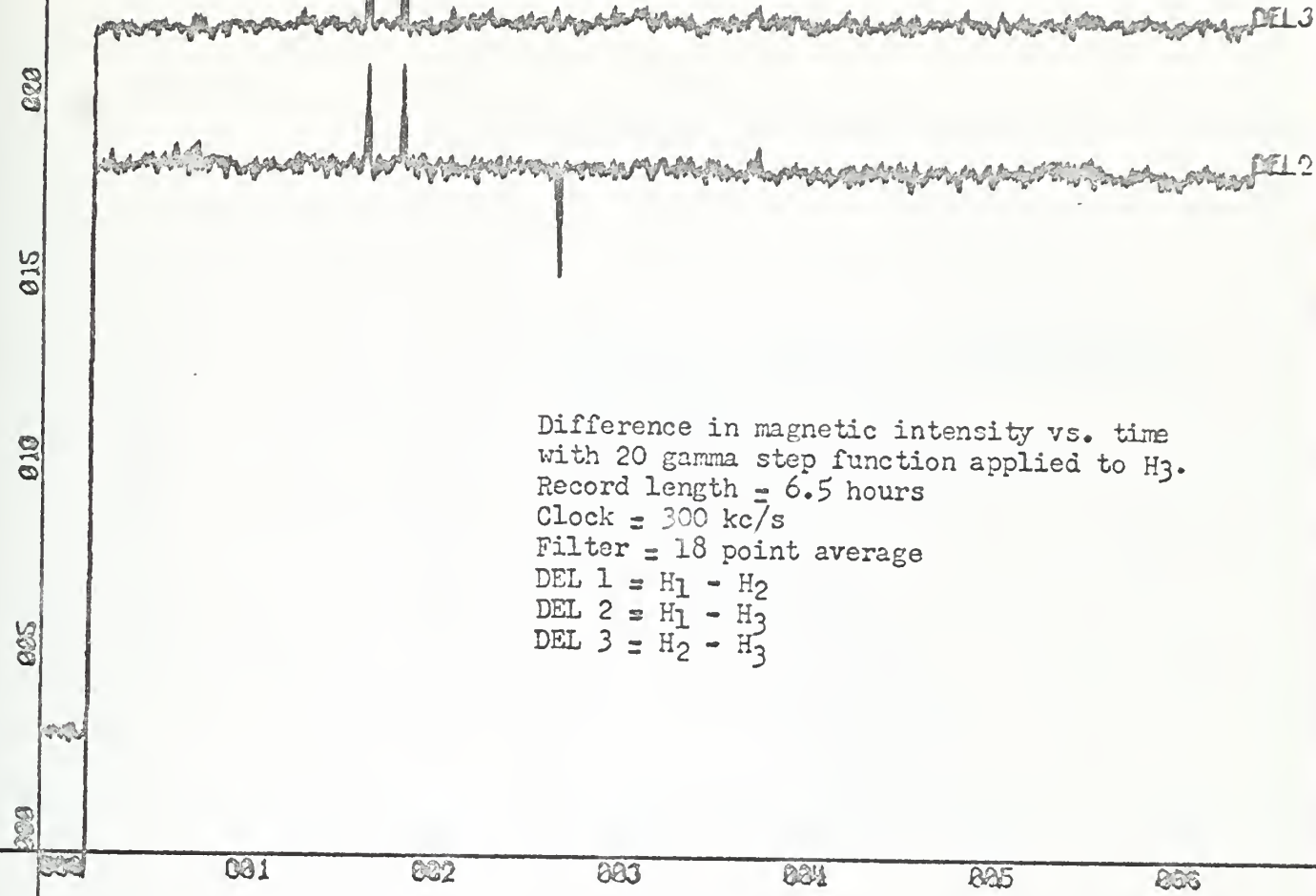

Difference in magnetic intensity vs. time
with 20 gamma step function applied to H₃.
Record length = 6.5 hours
Clock = 300 kc/s
Filter = 18 point average
DEL 1 = H₁ - H₂
DEL 2 = H₁ - H₃
DEL 3 = H₂ - H₃

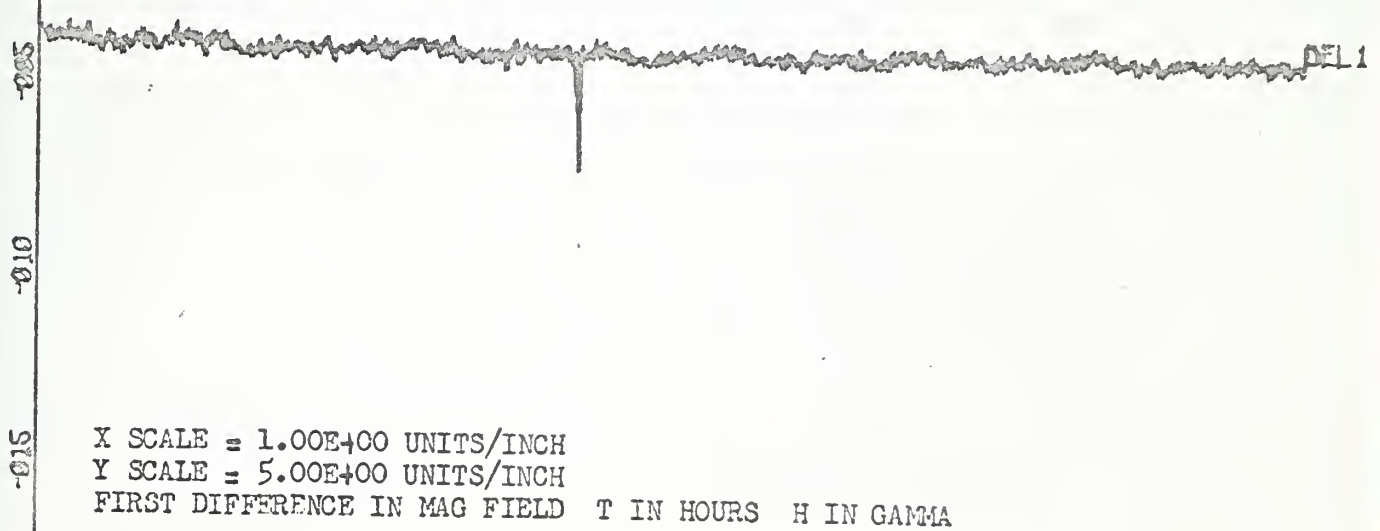

X SCALE = 1.00E+00 UNITS/INCH
Y SCALE = 5.00E+00 UNITS/INCH
FIRST DIFFERENCE IN MAG FIELD T IN HOURS H IN GAMMA

APPENDIX I

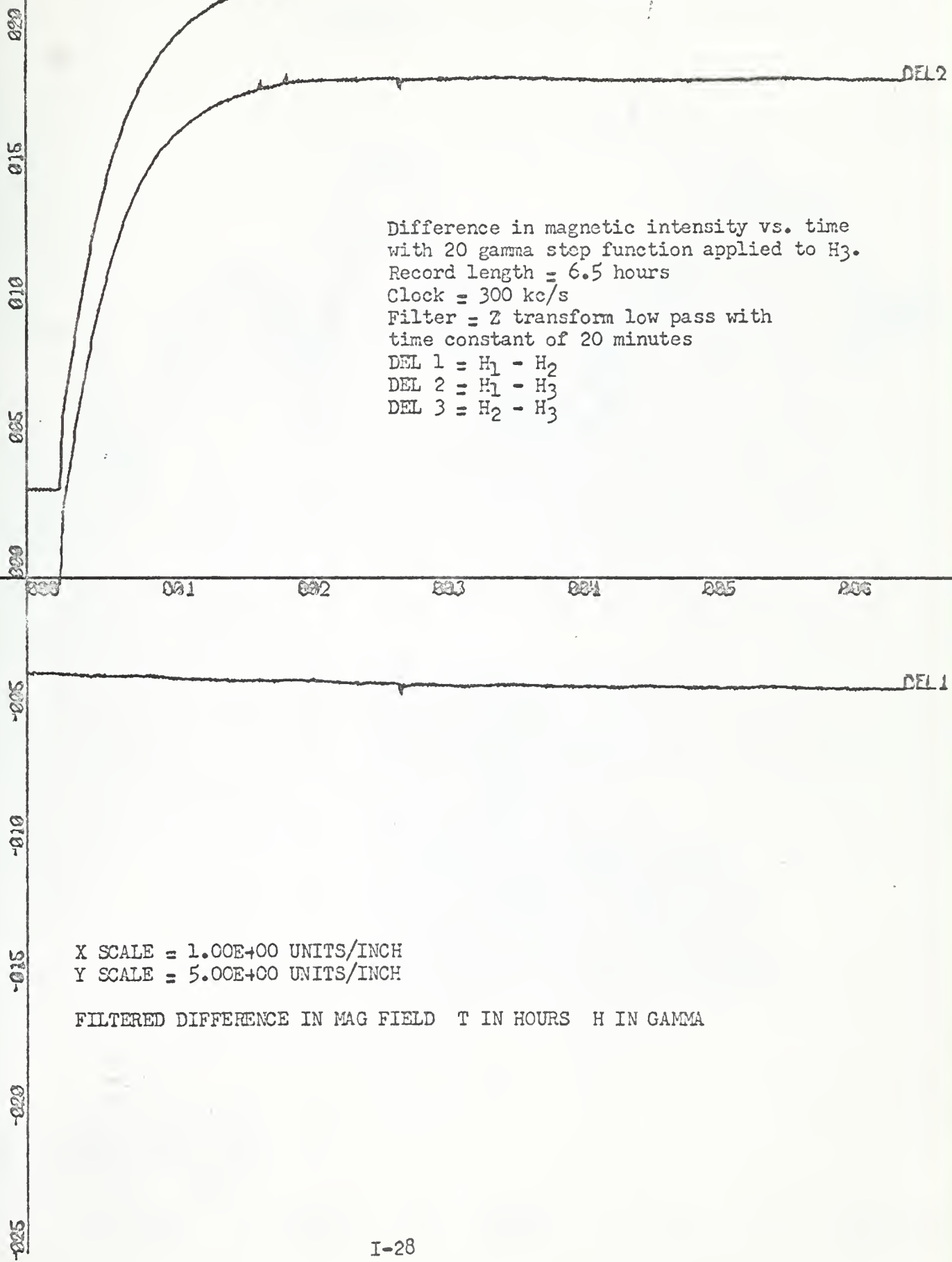

Difference in magnetic intensity vs. time
 with 20 gamma step function applied to H₃.
 Record length = 6.5 hours
 Clock = 300 kc/s
 Filter = Z transform low pass with
 time constant of 20 minutes
 DEL 1 = H₁ - H₂
 DEL 2 = H₁ - H₃
 DEL 3 = H₂ - H₃

X SCALE = 1.00E+00 UNITS/INCH
 Y SCALE = 5.00E+00 UNITS/INCH

FILTERED DIFFERENCE IN MAG FIELD T IN HOURS H IN GAMMA

APPENDIX I

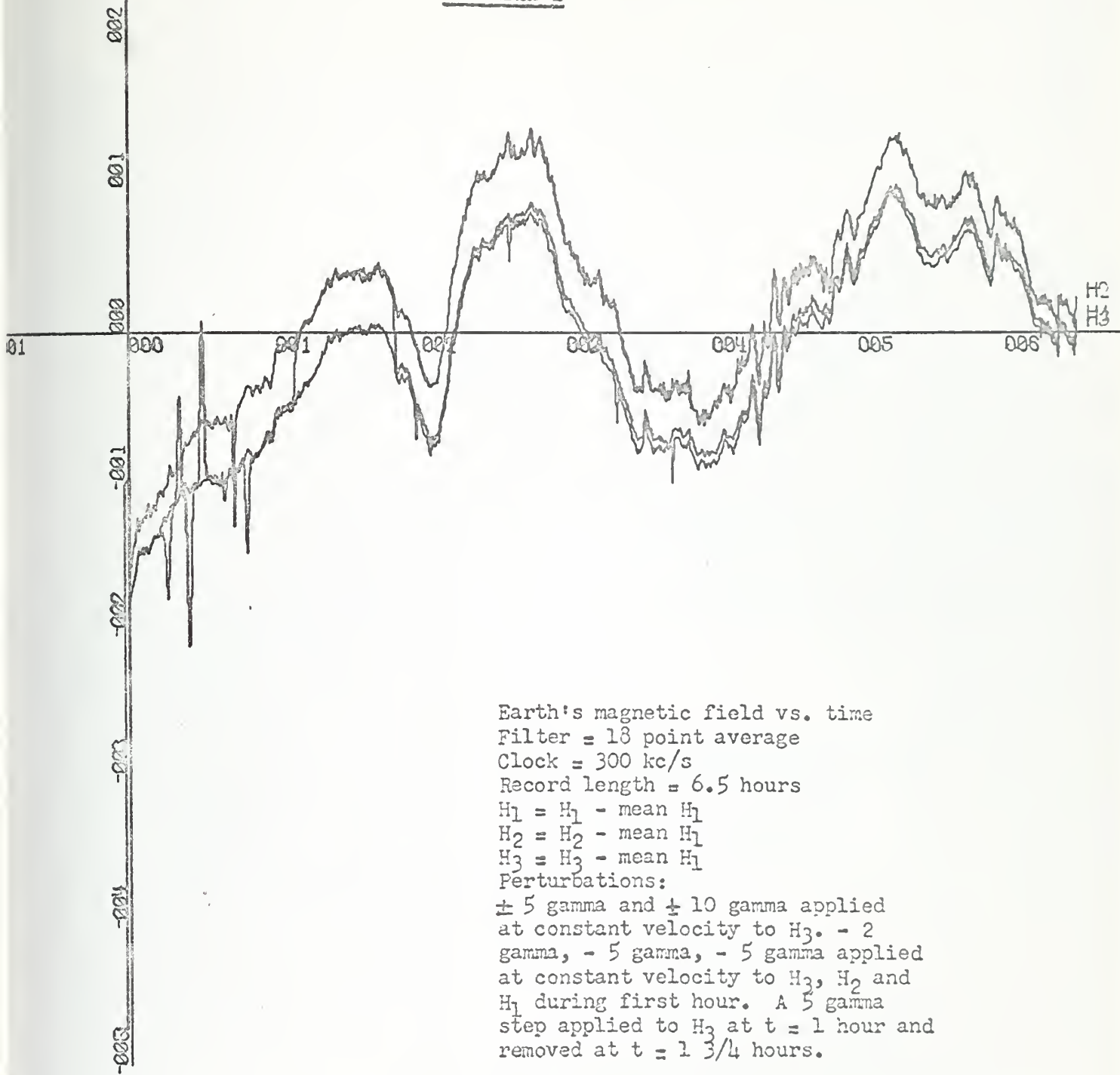

Earth's magnetic field vs. time

Filter = 18 point average

Clock = 300 kc/s

Record length = 6.5 hours

$H_1 = \bar{H}_1$ - mean H_1

$H_2 = \bar{H}_2$ - mean H_1

$H_3 = \bar{H}_3$ - mean H_1

Perturbations:

± 5 gamma and ± 10 gamma applied

at constant velocity to H_3 . - 2

gamma, - 5 gamma, - 5 gamma applied

at constant velocity to H_3 , H_2 and

H_1 during first hour. A 5 gamma

step applied to H_3 at $t = 1$ hour and

removed at $t = 1 \frac{3}{4}$ hours.

X-SCALE = $1.00E+00$ UNITS/INCH

Y-SCALE = $1.00E+01$ UNITS/INCH

ANDERSON BOX 263

EARTH'S MAGNETIC FIELD VS TIME T IN HRS H GAMMA

APPENDIX I

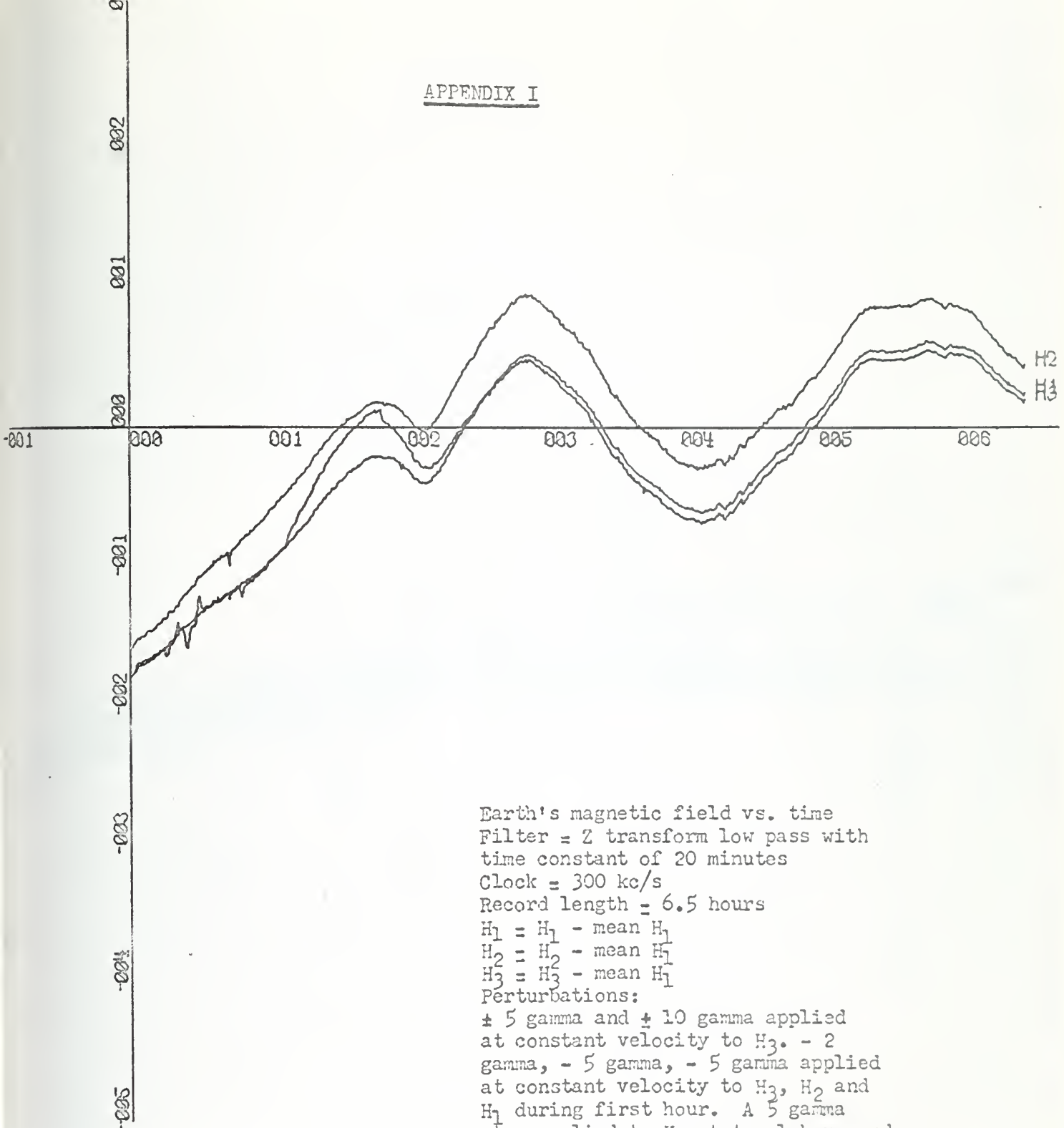

Earth's magnetic field vs. time
Filter = Z transform low pass with
time constant of 20 minutes
Clock = 300 kc/s
Record length = 6.5 hours
 $H_1 = H_1$ - mean H_1
 $H_2 = H_2$ - mean H_1
 $H_3 = H_3$ - mean H_1
Perturbations:
 ± 5 gamma and ± 10 gamma applied
at constant velocity to H_3 . - 2
gamma, - 5 gamma, - 5 gamma applied
at constant velocity to H_3 , H_2 and
 H_1 during first hour. A 5 gamma
step applied to H_3 at $t = 1$ hour and
removed at $t = 1 \frac{3}{4}$ hours.

X-SCALE = 1.00E+00 UNITS/INCH.

Y-SCALE = 1.00E+01 UNITS/INCH.

ANDERSON FILTER

EARTHS MAGNETIC FIELD VS TIME T IN HRS H GAMM

APPENDIX I

Earth's magnetic field vs. time

Filter = 2 point average

Clock = 300 kc/s

Record length = 1 hour

$H_1 = H_1 - \text{mean } H_1$

$H_2 = H_2 - \text{mean } H_1$

$H_3 = H_3 - \text{mean } H_1$

Perturbations:

± 5 gamma and ± 10 gamma applied at constant velocity to H_3 . -2 gamma, -5 gamma, -5 gamma applied at constant velocity to H_3 , H_2 and H_1 during first hour. A 5 gamma step applied to H_3 at $t = 1$ hour and removed at $t = 1 \frac{3}{4}$ hours.

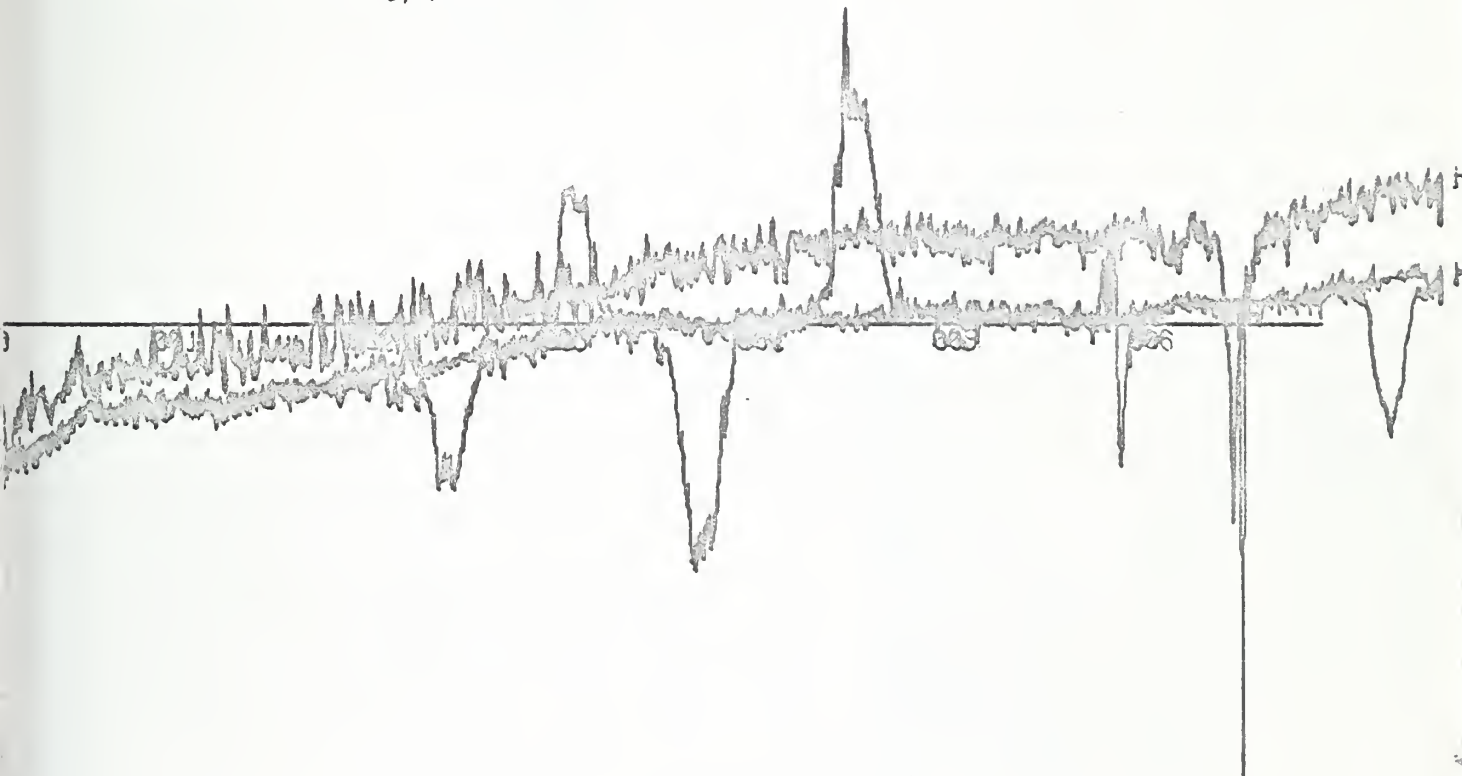

X SCALE = 1.00E+00 UNITS/INCH

Y SCALE = 1.00E+01 UNITS/INCH

EARTH'S MAGNETIC FIELD VS TIME T IN MINUTES H IN GAMMA

APPENDIX I

Earth's magnetic field vs. time
Filter = Z transform low pass with
time constant of 100 seconds.

Clock = 300 kc/s

Record length = 1 hour

$H_1 = H_1 - \text{mean } H_1$

$H_2 = H_2 - \text{mean } H_1$

$H_3 = H_3 - \text{mean } H_1$

Perturbations:

= 5 gamma and = 10 gamma applied
at constant velocity to H_3 . - 2
gamma, - 5 gamma, - 5 gamma applied
at constant velocity to H_3 , H_2 and
 H_1 during first hour. A 5 gamma
step applied to H_3 at $t = 1$ hour
and removed at $t = 1 \frac{3}{4}$ hours.

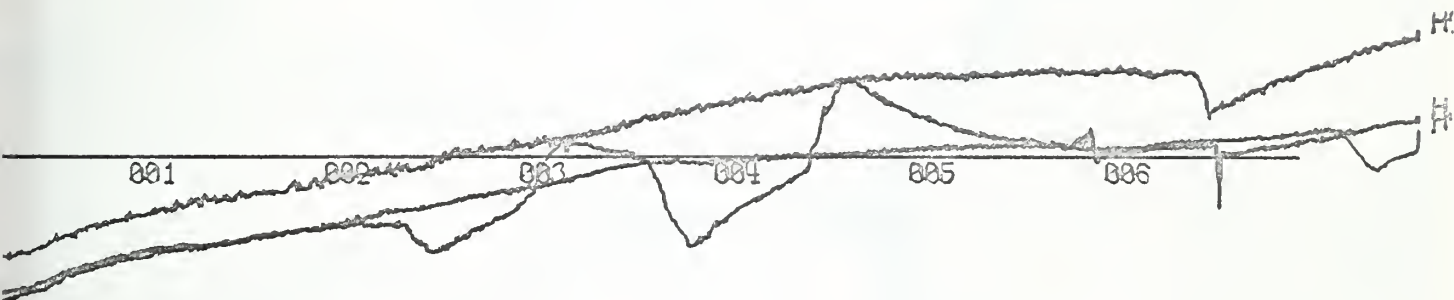

X SCALE = 1.00E-00 UNITS/INCH

Y SCALE = 1.00E-01 UNITS/INCH

EARTH'S MAGNETIC FIELD VS TIME T IN MINUTES H IN GAMMA

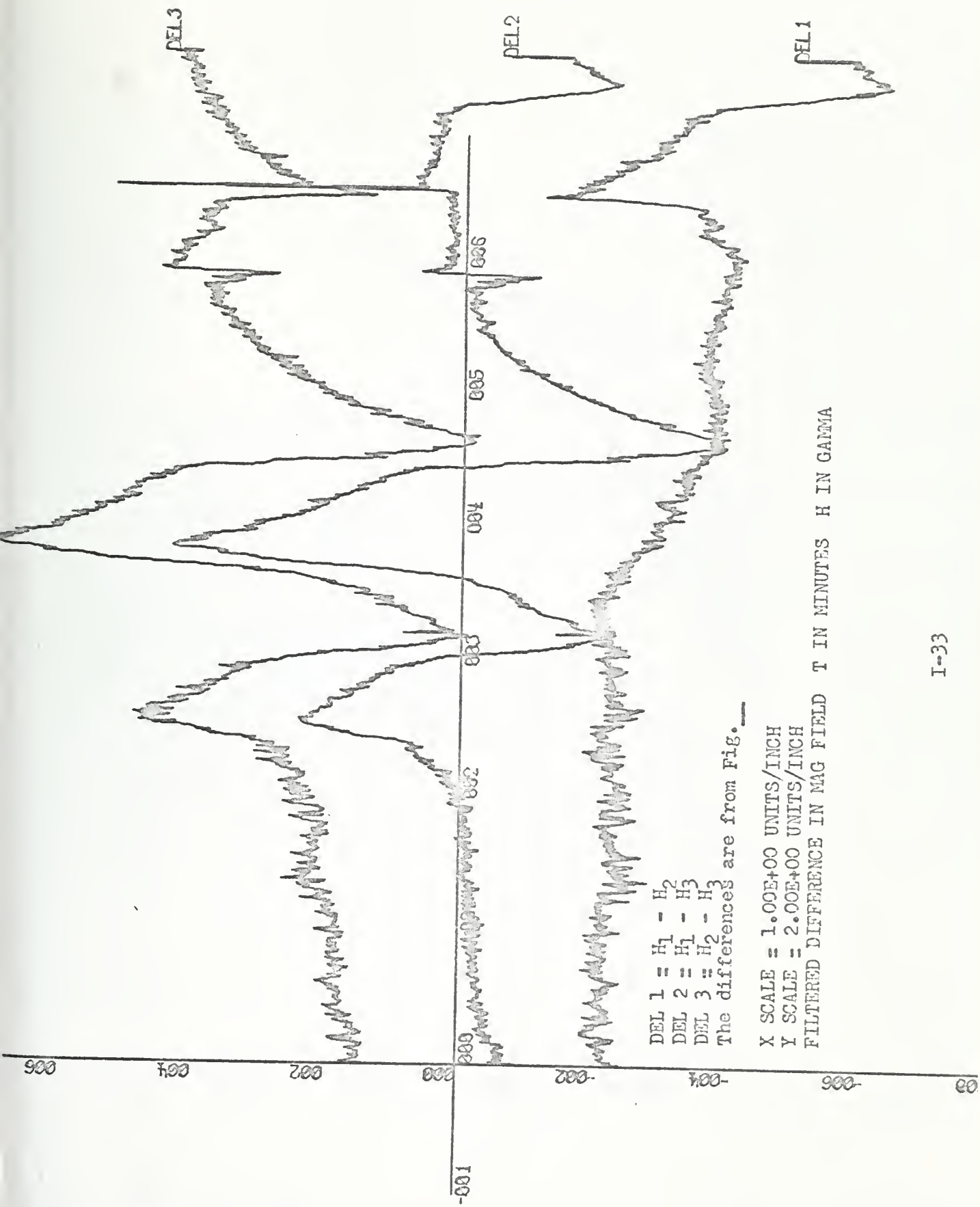

DEL 1 = $H_1 - H_2$
 DEL 2 = $H_1 - H_3$
 DEL 3 = $H_2 - H_3$
 The differences are from Fig.

X SCALE = 1.00E+00 UNITS/INCH
 Y SCALE = 2.00E+00 UNITS/INCH
 FILTERED DIFFERENCE IN MAG FIELD T IN MINUTES H IN GAMMA

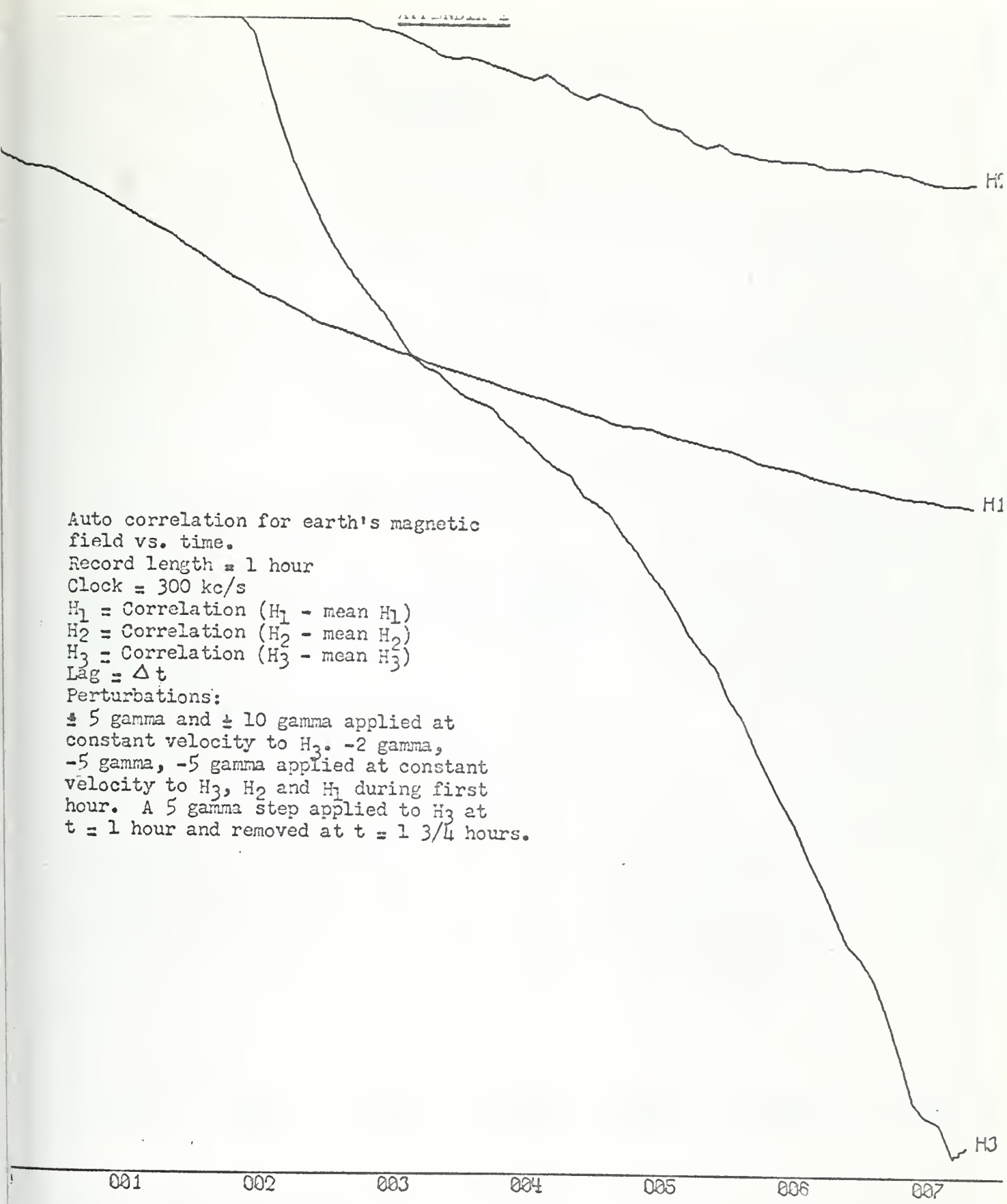

Auto correlation for earth's magnetic field vs. time.

Record length = 1 hour

Clock = 300 kc/s

H_1 = Correlation (H_1 - mean H_1)

H_2 = Correlation (H_2 - mean H_2)

H_3 = Correlation (H_3 - mean H_3)

Lag = Δt

Perturbations:

± 5 gamma and ± 10 gamma applied at constant velocity to H_3 . -2 gamma, -5 gamma, -5 gamma applied at constant velocity to H_3 , H_2 and H_1 during first hour. A 5 gamma step applied to H_3 at $t = 1$ hour and removed at $t = 1 \frac{3}{4}$ hours.

001

002

003

004

005

006

007

X-SCALE = 1.00E+01 UNITS/INCH.

Y-SCALE = 1.00E+00 UNITS/INCH.

ANDERSON BOX 263

ITOCORRELATION FUNCTION Y IN PRODUCTS X IN LAGS

APPENDIX I

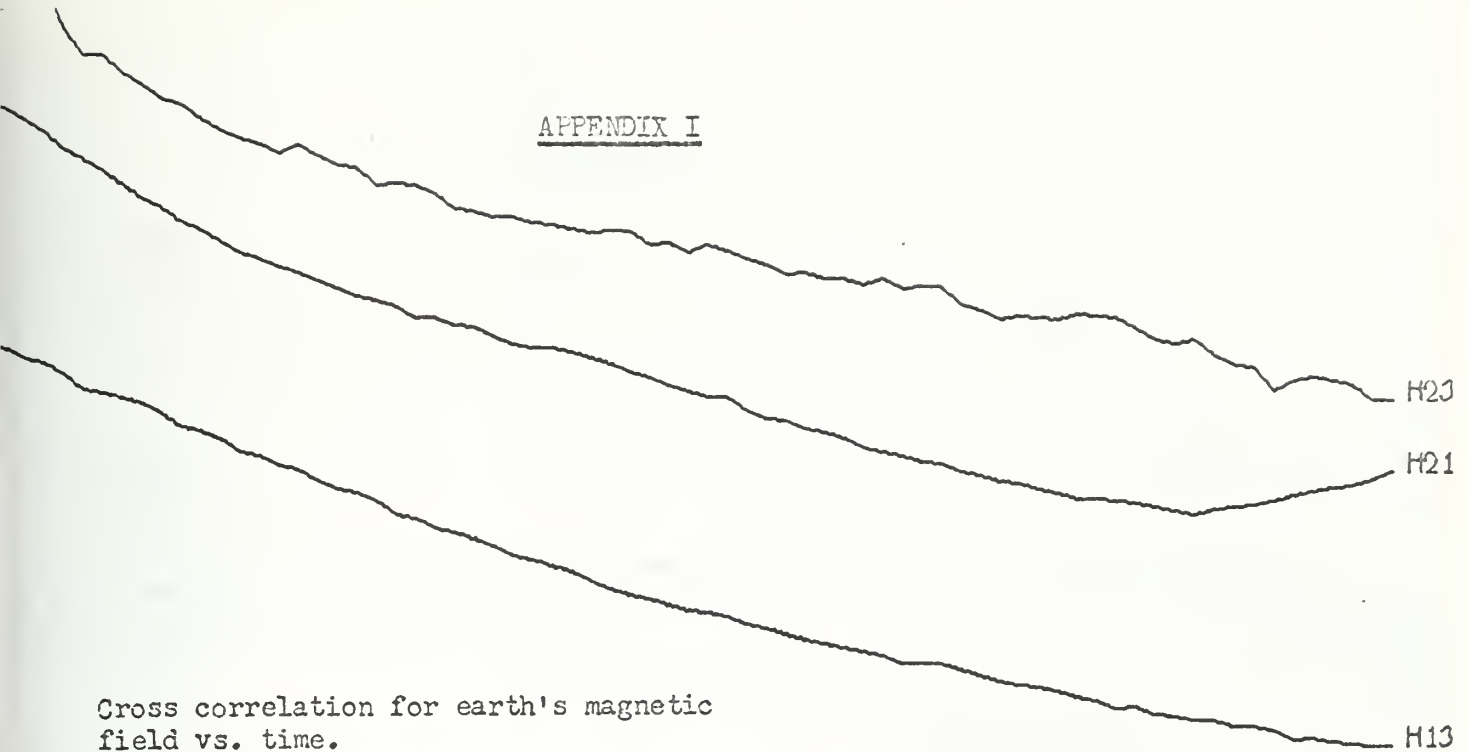

Cross correlation for earth's magnetic field vs. time.

Record length = 1 hour

Clock = 300 kc/s

H_{12} = Correlation (H_1 -mean H_1 and H_2 -mean H_2)

H_{13} = Correlation (H_1 -mean H_1 and H_3 -mean H_3)

H_{23} = Correlation (H_2 -mean H_2 and H_3 -mean H_3)

Lag = Δt

Perturbations:

± 5 gamma and ± 10 gamma applied at constant velocity to H_3 . -2 gamma, -5 gamma, -5 gamma applied at constant velocity to H_3 , H_2 and H_1 during first hour. A 5 gamma step applied to H_3 at $t = 1$ hour and removed at $t = 1 \frac{3}{4}$ hours.

001

002

003

004

005

006

007

X-SCALE = $1.00E+01$ UNITS/INCH

Y-SCALE = $1.00E+00$ UNITS/INCH

PERSON BOX 263

CORRELATION FUNCTION Y IN PRODUCTS X IN LAGS

APPENDIX I

Coherence for earth's magnetic field
vs. time.

Record length = 1 hour

Clock = 300 kc/s

H_{12} = Coherence of H_1 and H_2

H_{13} = Coherence of H_1 and H_3

H_{23} = Coherence of H_2 and H_3

Lag = Δt

Perturbations:

± 5 gamma and ± 10 gamma applied at
constant velocity to H_3 . -2 gamma,
 -5 gamma, -5 gamma applied at constant
velocity to H_3 , H_2 and H_1 during first
hour. A 5 gamma step applied to H_3 at
 $t = 1$ hour and removed at $t = 1 \frac{3}{4}$ hours.

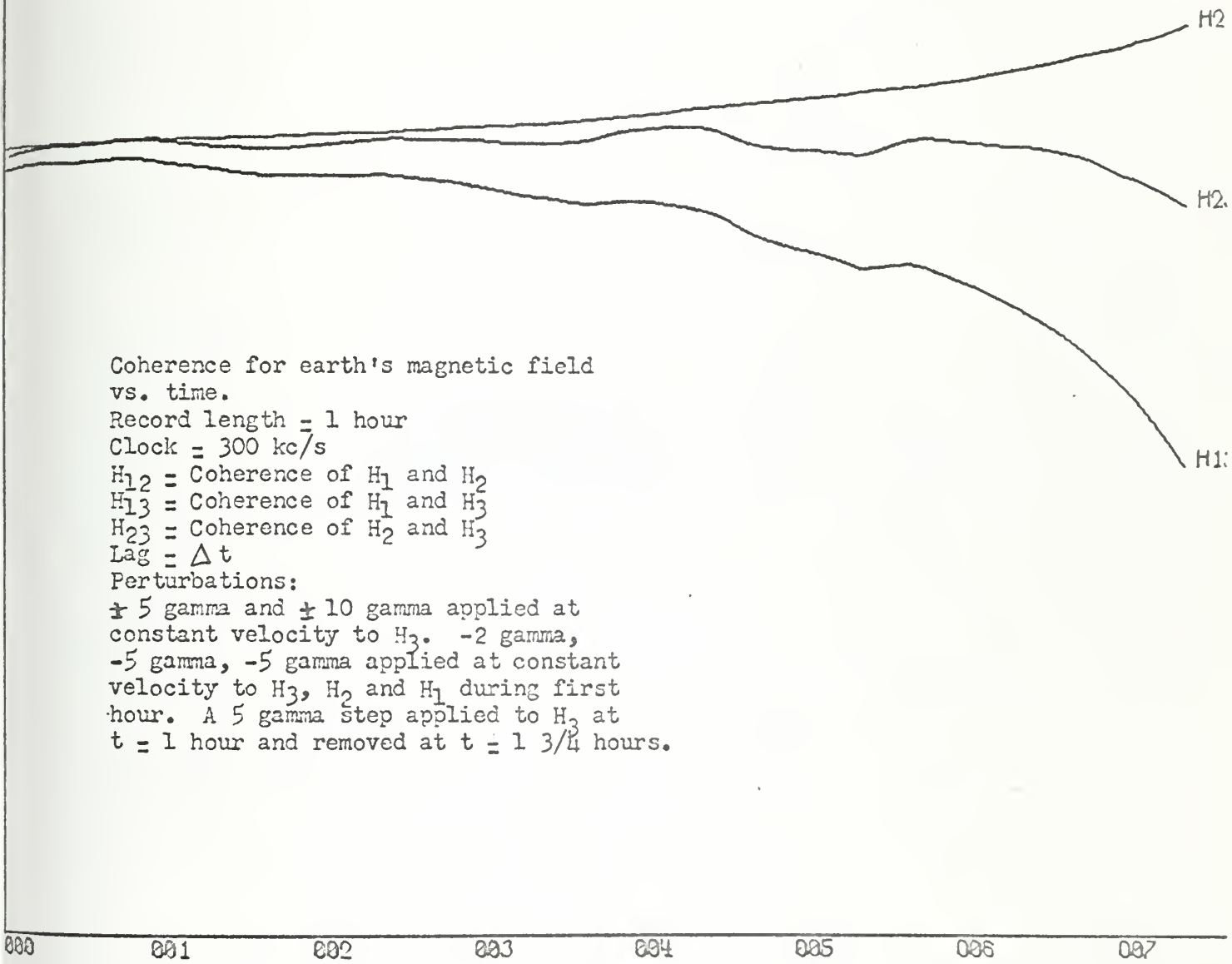

X-SCALE = $1.00E+01$ UNITS/INCH.

Y-SCALE = $2.00E-01$ UNITS/INCH.

ANDERSON BOX 263

COHERENCE

FUNCTION Y IN COH X IN LAGS

APPENDIX II

160 PROGRAMS AND
OPERATOR INSTRUCTIONS

APPENDIX II

160 PROGRAMS AND OPERATOR INSTRUCTIONS

<u>Starting Addresses</u>	<u>Function</u>
0000	Rewind
0002	Read
0004	Search
0006	Write
0010	Write identification Block
0100	Main Input Program

<u>Error Stops</u>	<u>Cause</u>
ERRO1	77 ₈ of current input in error
ERRO2	Memory storage not complete
ERRO4	End of storage tape
ERRO3	163 not ready

<u>Addresses of Important Counters</u>	<u>Information</u>
0057	Number of blocks written on storage tape
0045	Current storage location in memory
0046	Number of zero words in memory

Operator Instructions

1. Load program and make the necessary cable connections.
2. Set identifying records in cells 30₈ to 37₈.
3. Write identifying block (run from P = 010). Stop at P = 100.
4. Set cell 100 = 2200
57 = 0
5. Start Ampex C.P. 100 and run from P = 100. Stop when tape is finished or ERR stop.

APPENDIX II
INPUT PROGRAM

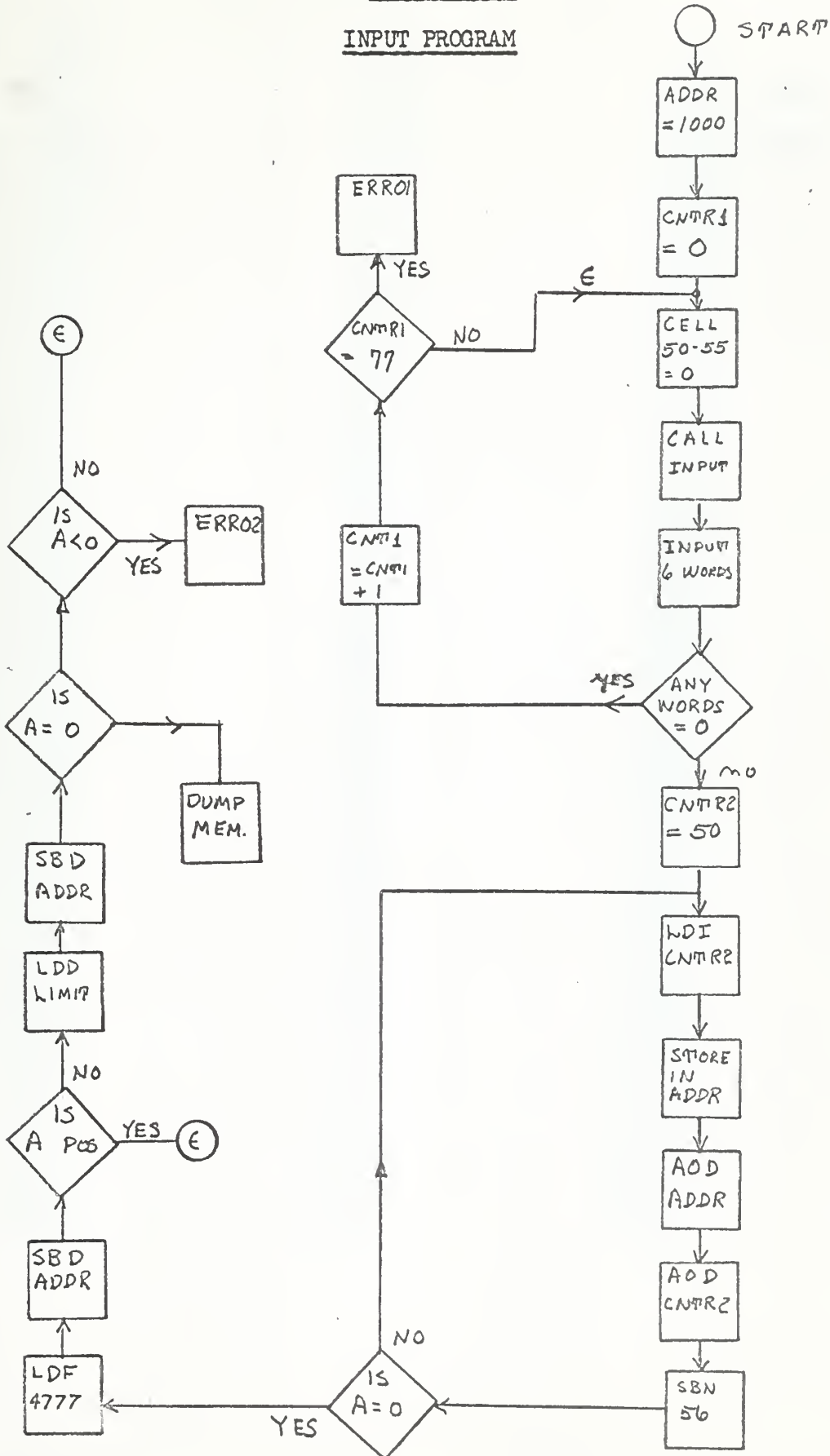

APPENDIX II

0100	2200	LDF00
0101	1000	1000
0102	4045	STD45 (ADDR)
0103	0400	LDN00
0104	4046	STD46 (CNTR1)
0105	0400	LDN00
0106	4150	STI50
0107	4151	STI51
0110	4152	STI52
0111	4153	STI53
0112	4154	STI54
0113	4155	STI55
0114	7500	EXF00
0115	0500	0500
0116	7203	INF03
0117	0620	0620
0120	6102	NZF02
0121	0600	0600
0122	1600	LSF00
0123	0607	ADN07
0124	6115	NZF15
0125	2150	LDI50
0126	6013	ZJF13
0127	2151	LDI51
0130	6011	ZJF11
0131	2152	LDI52
0132	6007	ZJF07
0133	2153	LDI53
0134	6005	ZJF05
0135	2154	LDI54
0136	6003	ZJF03
0137	2155	LDI55
0140	6105	NZF05
0141	5446	AOD46
0142	0777	SBN77
0143	6536	NZB36
0144	0001	ERR01
0145	2050	LBD50
0146	4047	STD47
0147	2147	LDI47
0150	4145	STI45
0151	5445	AOD45
0152	5447	AOD47
0153	3456	SBD56
0154	6505	NZB05
0155	2200	LDF00
0156	4777	4777

APPENDIX II

0157	3445	SBD45
0160	6653	PJB53
0161	2044	LDD44
0162	3445	SBD45
0163	6003	ZJF03
0164	6657	PJB57
0165	0002	ERR02
0166	7101	JFI01
0167	0172	WRITE
0170	1000	
0171	7700	HLT00

ADDITIONAL CELLS USED

0044	LIMIT	(PUT IN LIMIT)
0045	ADDR	7600
0046	CNTR 1	
0047	CNTR 2	
0050	BUFFER STORAGE	
0051	BUFFER STORAGE	
0052	BUFFER STORAGE	
0053	BUFFER STORAGE	
0054	BUFFER STORAGE	
0055	BUFFER STORAGE	
0057	NUMBER OF MEMORY DUMPS	

APPENDIX II

MEMORY DUMP TO M.T.

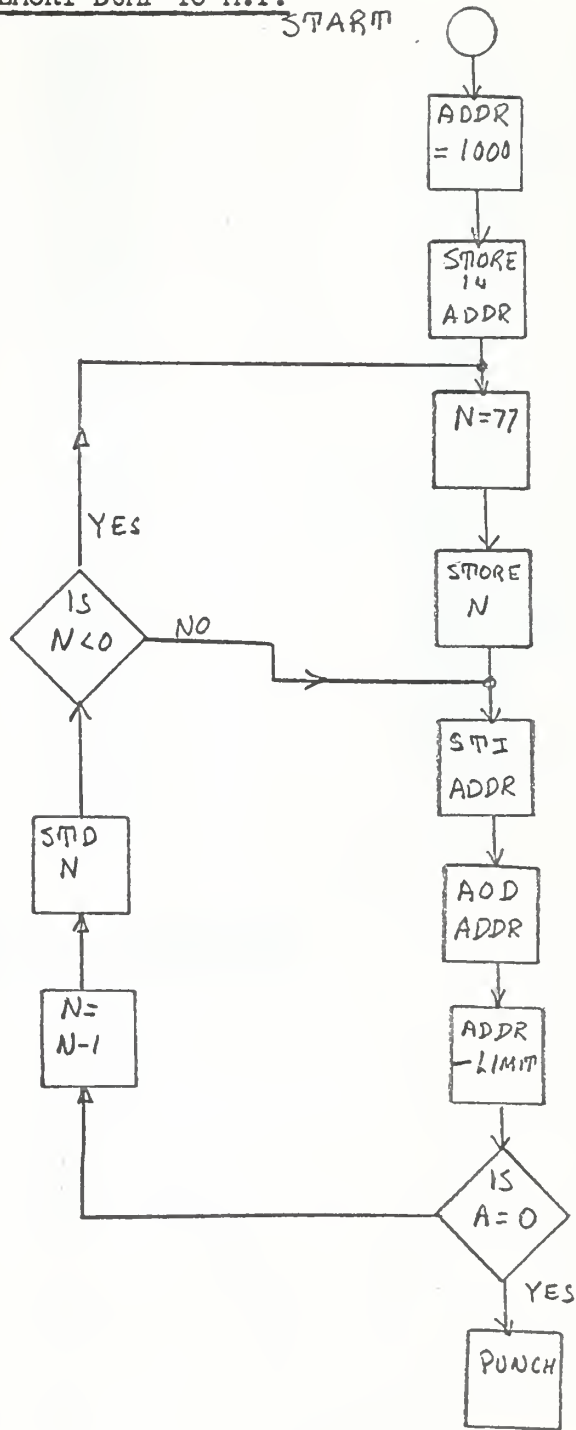

APPENDIX II

0172	5457	AOD57
0173	2600	LCF00
0174	7776	
0175	4060	STD60
0176	7500	EXF00
0177	1141	REQ STAT
0200	7600	INA00
0201	0202	LPN02
0202	6004	ZJF04
0203	5460	AOD60
0204	6506	NZB06
0205	0003	ERR03
0206	7500	EXF00
0207	2111	2111
0210	7303	OUT03
0211	7600	TERM OUT (LIMIT + 1)
0212	6102	NZF02
0213	1000	INIT WRIT
0214	7500	EXF00
0215	1141	REQ STAT
0216	7600	INA00
0217	0240	LPN40
0220	6103	NZF03
0221	7101	JFI01
0222	0100	00
0223	7700	HLT00

DUMP TO PAPER TAPE

0163	7500
0164	4104
0165	7303
0166	7600
0167	6102
0170	1000
0171	7700

APPENDIX II

DAILY IDENTIFICATION

USE 8 CELLS

0030 0070
0031 0064

0032 0032
0033 0030
0034 0060

0035 0072
0036 0062

0037 0045

EXAMPLE

2 day
3

J
A month
N

6
4 year

CAR RET

APPENDIX II
DAILY RECORD TO M.T.

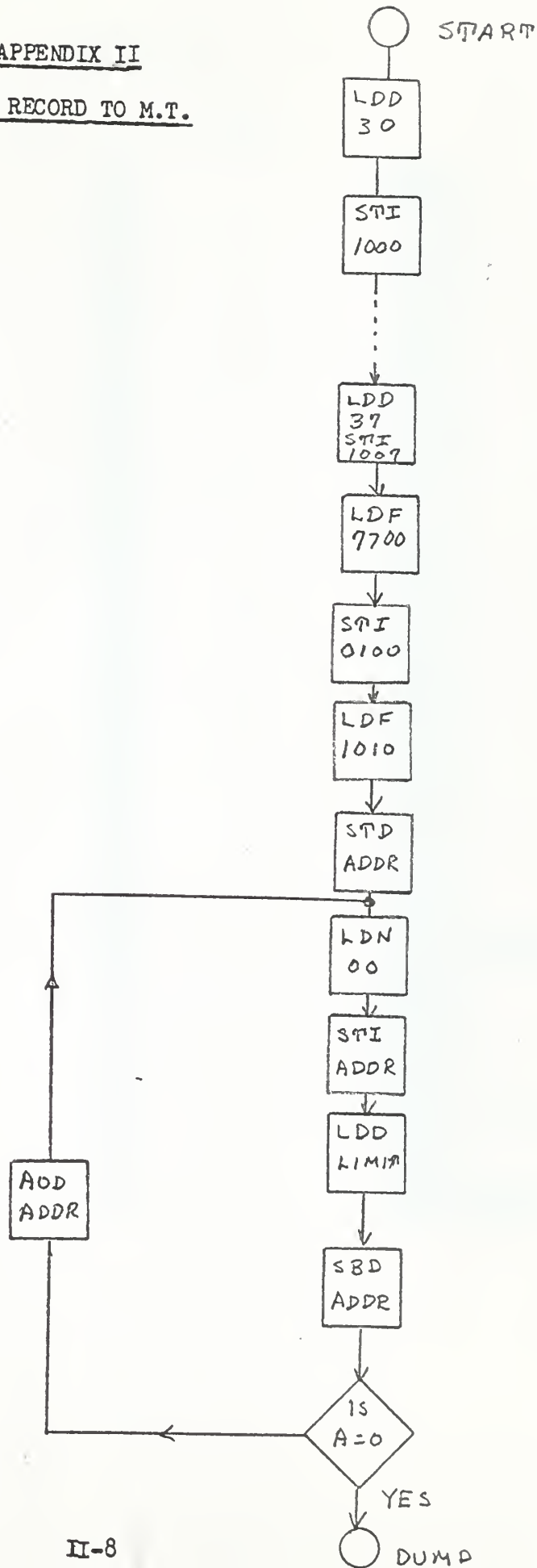

APPENDIX II

DAILY RECORD TO M.T.

0224	2030	LDD30
0225	4100	STI00
0226	1000	1000
0227	2031	LDD31
0230	4100	STI00
0231	1001	1001
0232	2032	LDD32
0233	4100	STI00
0234	1002	1002
0235	2033	LDD33
0236	4100	STI00
0237	1003	1003
0240	2034	LDD34
0241	4100	STI00
0242	1004	1004
0243	2035	LDD35
0244	4100	STI00
0245	1005	1005
0246	2036	LDD36
0247	4100	STI00
0250	1006	1006
0251	2037	LDD37
0252	4100	STI00
0253	1007	1007
0254	2200	LDF00
0255	7700	7700
0256	4100	STI00
0257	0100	0100
0260	2200	LDF00
0261	1010	1010
0262	4045	STD45 (ADDR)
0263	0400	LDN00
0264	4145	STI45
0265	2044	LDD44
0266	3445	SBD45
0267	6003	ZJF03
0270	5445	AOD45 (ADDR)
0271	6506	NZB06
0272	7101	JFI01
0273	0172	0172 (DUMP)
0274	7700	NORMAL STOP

REWIND, READ AND

DAILY RECORD SEARCH

REWIND
START

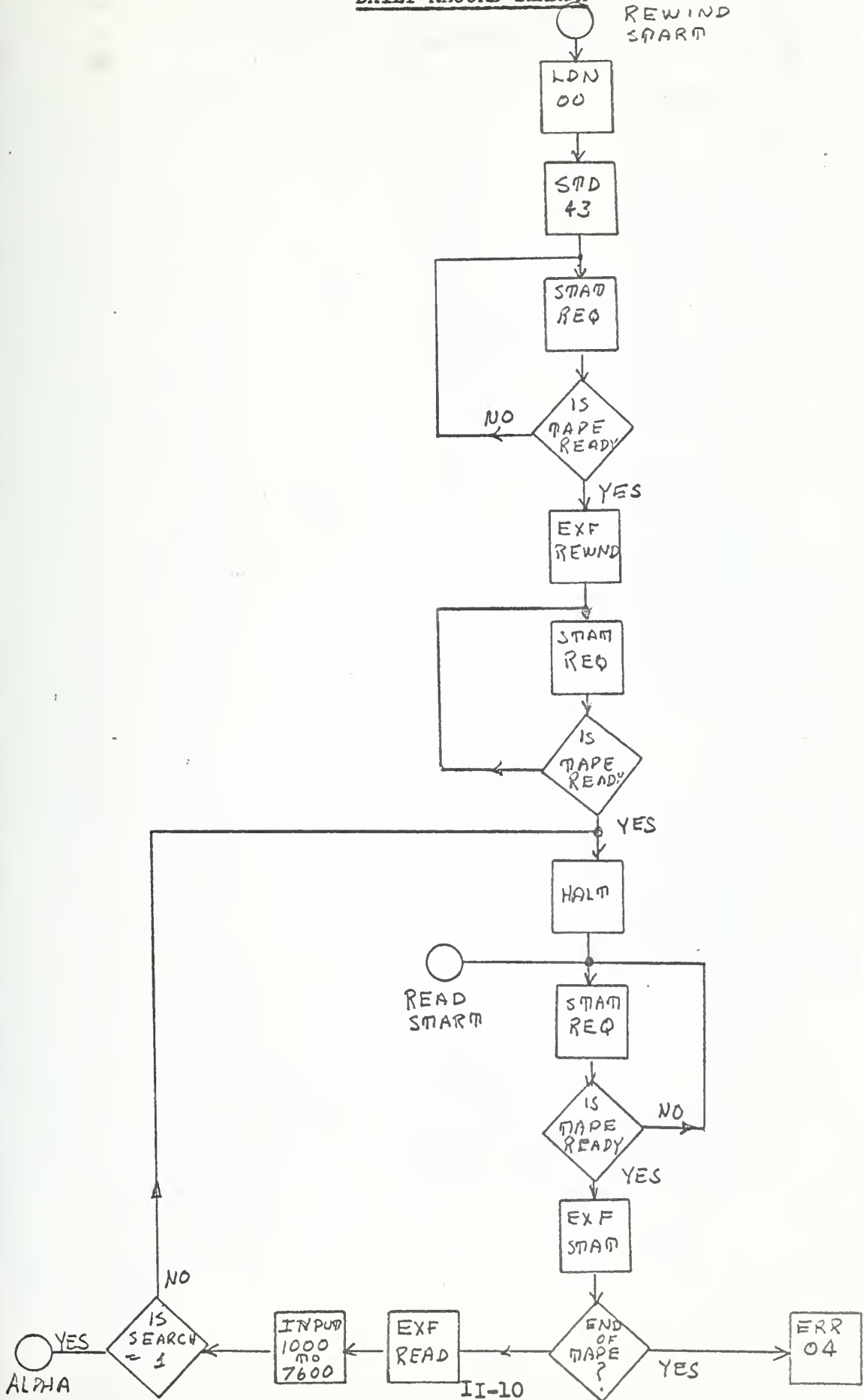

REWIND, READ AND
DAILY RECORD SEARCH

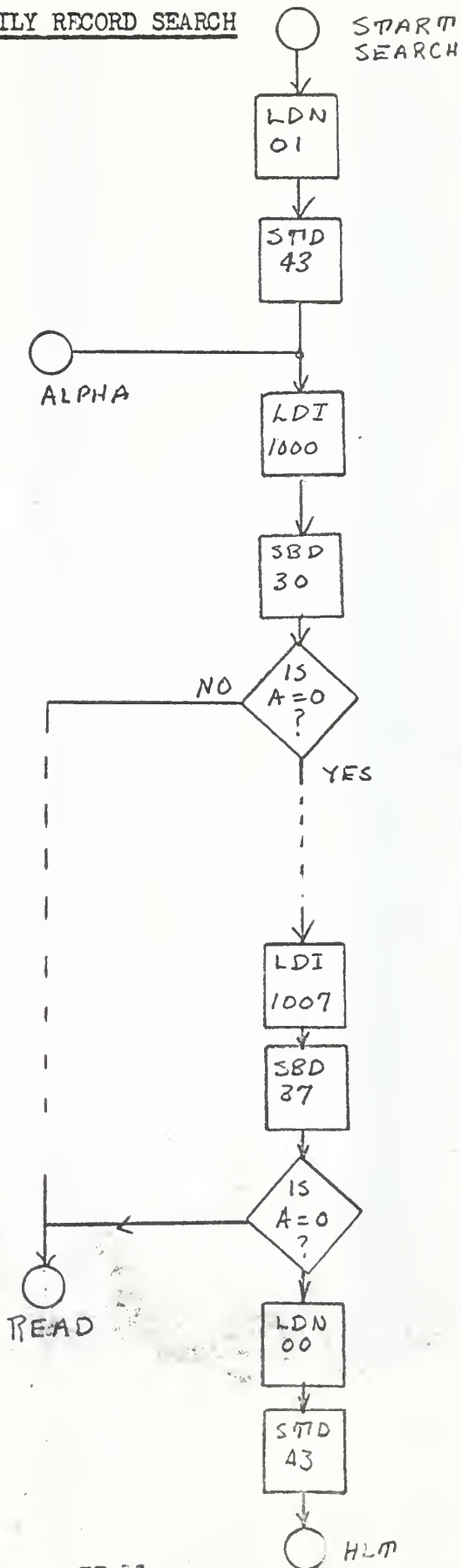

APPENDIX II

Start			
Rewind	0275	0400	LDN00
	0276	4043	STD43
	0277	7500	EXF00
	0300	1141	REQ STAT
	0301	7600	INA00
	0302	0202	LPN02
	0303	6504	NZB04
	0304	7500	EXF00
	0305	1161	REWIND
	0306	7500	EXF00
	0307	1141	REQ STAT
	0310	7600	INA00
	0311	0202	LPN02
	0312	6504	NZB04
Read	0313	7700	HLT00
Start	0314	7500	EXF00
	0315	1141	REQ STAT
	0316	7600	INA0C
	0317	0202	LPN02
	0320	6504	NZB04
	0321	7500	EXF00
	0322	2111	EXF11 READ
	0323	7203	OUT03
	0324	7600	TERM READ
	0325	6102	NZF02
	0326	1000	INIT READ
	0327	7500	EXF00
	0330	1141	REQ STAT
	0331	7600	INA00
	0332	0240	LPN40
	0333	6002	ZJF02
	0334	0004	ERR04 (END OF
	0335	2043	LDD43 TAPE)
	0336	0701	SBN01
	0337	6004	ZJF04
	0340	6525	NZB25
Search	0341	0401	LDN01
Start	0342	4043	STD43 (SEARCH)
	0343	2100	LDI00
	0344	1000	1000
	0345	3430	SBD30
	0346	6532	NZB32
	0347	2100	LDI00
	0350	1001	1001
	0351	3431	SBD31
	0352	6536	NZB36
	0353	2100	LDI00

APPENDIX II

0354	1002	1002
0355	3432	SBD32
0356	6542	NZB42
0357	2100	LDI00
0360	1003	1003
0361	3433	SBD33
0362	6546	NZB46
0363	2100	LDI00
0364	1004	1004
0365	3434	SBD34
0366	6552	NZB52
0367	2100	LDI00
0370	1005	1005
0371	3435	SBD35
0372	6556	NZB56
0373	2100	LDI00
0374	1006	1006
0375	3436	SBD36
0376	6114	NZF14
0377	2100	LDI00
0400	1007	1007
0401	3437	SBD37
0402	6110	NZF10
0403	2100	LDI00
0404	1010	1010
0405	6105	NZF05
0406	0400	LDN00
0407	4043	STD43
0410	7101	JFI01
0411	0077	0077
0412	7101	JFI01
0413	0314	

TEST TAPE 22 BLOCKS DATA

M = 47145₁₀
= 0013 4051₈
N₂ N₁

LIMIT CELL 44 = 7600
ADDR CELL 45
CNTR 2 CELL 21
N₁ CELL 22
N₂ CELL 23
CNTR 1 CELL 20

0526	7700	HLT00
0527	0400	LDN00
0530	4021	STD21
0531	2200	LDF00
0532	1000	1000

APPENDIX II

0533	4045	STD45
0534	0413	LDN13
0535	4023	STD23
0536	0400	LDN00
0537	4020	STD20
0540	2200	LDF00
0541	4051	4051
0542	4022	STD22
0543	2021	LDD21
0544	0726	SRN26
0545	6417	ZJB17
0546	2023	LDD23
0547	4145	STI45
0550	5445	AOD45
0551	2022	LDD22
0552	4145	STI45
0553	5445	AOD45
0554	5422	AOD22
0555	5420	AOD20
0556	2200	LDF00
0557	4777	4777
0560	3445	SBD45
0561	6207	PJF07
0562	2044	LDD44
0563	3445	SBD45
0564	6104	NZF04
0565	5421	AOD21
0566	7101	JFI01
0567	0172	0172
0570	2020	LDD20
0571	0777	SBN77
0572	6434	ZJB34
0573	6525	NZB25

APPENDIX II

WRITE TEST TAPE

22 BLOCKS DATA

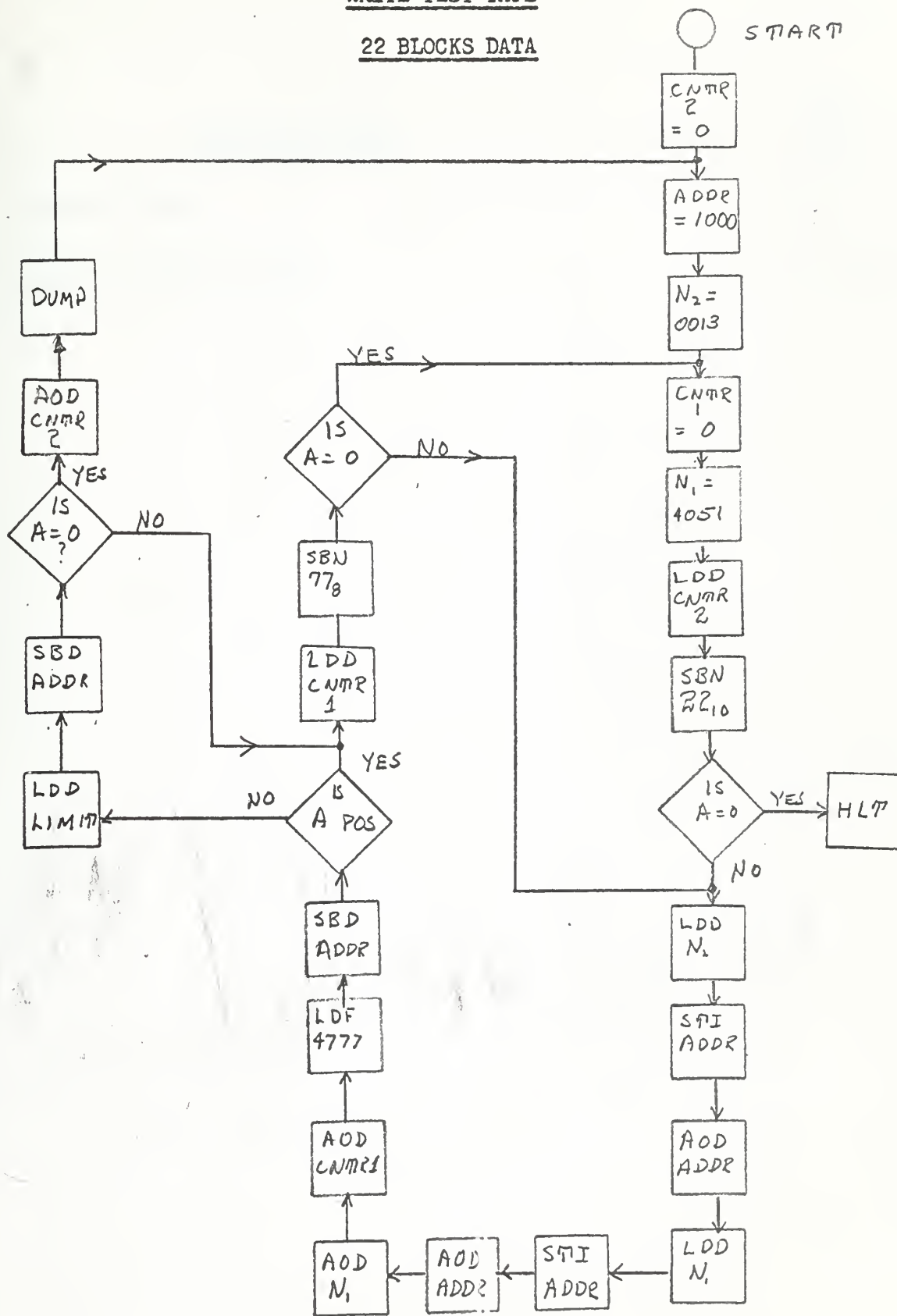

APPENDIX III

<u>FORTRAN PROGRAMS</u>	<u>PAGE</u>
ANALYSIS PROGRAM	1
SATELLITE DISPLAY PROGRAM	7

```

DIMENSION NDATA(864),DATE(100),H(1728),HONE(900),ITITLE(12),
HTWC(900),HTHRE(900),T(900),BIN1(100),BIN2(100),BIN3(100),X(100)
DO 5 J = 1,14
READ 5,DATE(J)
5 FORMAT(016)
CON(MASK = 0000000077777777B)
ENA(NDATA),INA(1).
STA(INIT),INA(864).
STA(ITERM),ENI(0).
6 CALL READ(3,INIT,ITERM,1)
DO 70 I=3,5
SLS1(7)
7 ADATE = DATE(I)
BDATE = DATE(I+1)
LDA(ADATA),SUR(NDATA +1),AJP1(6),
LDA(BDATE),SUB(NDATA +2),AJP1(6).
NBLOC = 0
30 CALL READ(3,INIT,ITERM,1)
NZRC = 0
DO 81 J=1,864
IF(NDATA(J)) 82,82,81
82 NZRO = NZRO+1
81 CONTINUE
ND = NDATA(3)
LDA(ND),AJPO(10).
K=C
DO 40 J=1,864
K=K+1
INDATA = NDATA(J)
LDA(INDATA),LDQ(MASK),ARS(24),STL(INLIST).
H(K)=INLIST
K=K+1
LDA(INDATA),LDQ(MASK),STL(INLIST).
SLS1(40).
40 H(K)=INLIST
AVE=0.
DO 50 J =1,1728
H(J) = H(J)/3.
H(J)=1024./H(J)*2348400.0
50 AVE = H(J) + AVE

```

```

C ZAPP PRINT 26, AVE
FILTER
NERR = 0
AVE = 0.
HBAR = 50950.0
DO 51 J=1,1728
DEV = ABSF(H(J)-HBAR)
IF(DEV-200.) 51,52,52
JCOUNT = J
52 NERR = NERR + 1
IF(J-3) 53,53,54
53 H(J) = H(J+3)
GO TO 51
54 H(J) = H(J-3)
51 AVE = AVE + H(J)
AVE = AVE/1728.
PRINT 26, AVE
PRINT 97,NERR,NZRO,JCOUNT
NBLOC = NBLOC + 1
WRITE TAPE 2, H
GO TO 30

```

```

10 REWIND 2
C THIS SECTION COMPUTES H VS TIME
C 18 PT AVE N IS TOTAL NUMBER OF POINTS PER DAY
TIME = - 6.5/704.
DO 60 L=1,NBLOC
READ TAPE 2,H
DO 62 J=1,32
H1BAR = 0.
H2BAR = 0.
H3BAR = 0.
DO 61 K=1,18
M = 3*K - 2 + (J - 1)*54
H1BAR = H(M) + H1BAR
H2BAR = H(M+1) + H2BAR
61 H3BAR = H(M+2) + H3BAR
N = J + (L-1)*32
HONE(N) = H1BAR/18.
HTWC(N) = H2BAR/18.
HTHRE(N) = H3BAR/18.
TIME = TIME + 6.5/704.
62 T(N) = TIME
60 CONTINUE

```

```

REWIND 2
PRINT 27,N
PRINT 27,M
NPTS=N
C MEAN VALUE OF DIFFERENCES
JERR = 0
IERR = 0
NERR = 0
DEL1 = 0.
DEL2 = 0.
DEL3 = 0.
DO 64 J = 1,NBLOC
READ TAPE 2,H
DO 64 L = 1,576
M = 3*L-2
DEL = H(M + 1) - H(M)
65 IF(ABSF(DEL)-40.) 65,66,66
DEL1 = DEL1 + DEL
GO TO 67
66 NERR = NERR + 1
67 DEL = H(M + 1) - H(M + 2)
IF(ABSF(DEL) - 40.) 68,69,69
68 DEL2 = DEL2 + DEL
GO TO 71
69 IERR = IERR + 1
71 DEL = H(M) - H(M + 2)
IF(ABSF(DEL) - 40.) 72,73,73
72 DEL3 = DEL3 + DEL
GO TO 64
73 JERR = JERR + 1
64 CONTINUE
REWIND 2
PRINT 97,NERR,IERR,JERR
97 FORMAT(3I20)
ABLOC = NBLOC
DEL1 = DEL1/(576.*ABLOC)
DEL2 = DEL2/(576.*ABLOC)
DEL3 = DEL3/(576.*ABLOC)
PRINT 49,DEL1,DEL2,DEL3

```

APPENDIX III

```

C DENSITY FUNCTION
STDEV1=0.
STDEV2=0.
STDEV3=0.
NERR = 0
IERR = 0
JERR = 0
XL=-25.
DO 45 K=1,100
BIN1(K)=0.
BIN2(K)=0.
BIN3(K)=0.
X(K)=XL
45 XL= XL+0.5
DO 74 J=1,NBLOC
READ TAPE 2,H
DO 74 L = 1,576
M = 3*L-2
STDEV1= (H(M+1)-H(M)-DEL1)**2 + STDEV1
STDEV2= (H(M+1)-H(M+2)-DEL2)**2 + STDEV2
STDEV3= (H(M)-H(M+2)-DEL3)**2 + STDEV3
DEL = H(M+1) - H(M)
IF(ABSF(DEL-DEL1)-25.)75,75,76
76 NERR = NERR + 1
75 DEL = H(M+1) - H(M+2)
IF(ABSF(DEL-DEL2)-25.)77,77,78
78 IERR = IERR + 1
77 DEL = H(M) - H(M+2)
IF(ABSF(DEL-DEL3)-25.)29,29,80
80 JERR = JERR + 1
29 DO 31 K=1,3
IF(K-2)32,33,34
32 DEL=H(M+1)-H(M)-DEL1
GO TO 35
33 DEL=H(M+1)-H(M+2)-DEL2
GO TO 35
34 DEL=H(M)-H(M+2)-DEL3
35 XL= -25.
DO 36 N=1,100
IF(DEL-XL) 37,37,38
38 IF(DEL-(XL+0.5))39,39,37
39 IF(K-2) 42,43,44
42 BIN1(N)=BIN1(N)+1.
GO TO 31
43 BIN2(N) = BIN2(N)+1.
GO TO 31

```

```

30 CONTINUE
31 CONTINUE
74 CONTINUE
STDEV1 =SQRT(STDEV1/(576.*ABLOC))
STDEV2 =SQRT(STDEV2/(576.*ABLOC))
STDEV3 =SQRT(STDEV3/(576.*ABLOC))
PRINT 49,STDEV1,STDEV2,STDEV3
PRINT 97,NERR,IERR,JERR
REWIND 2
C NORMALIZED DENSITY FUNCTION
AMAX=BIN1(1)
BMAX=BIN2(1)
CMAX=BIN3(1)
DO 200 J=1,100
IF(AMAX-BIN1(J))201,202,202
201 AMAX=BIN1(J)
202 IF(BMAX-BIN2(J))203,204,204
203 BM+XOBIM2(-)#####/#####S##S#####//#####S
204 IF(CMAX-BIN3(J))205,200,200
205 CMAX=BIN3(J)
200 CONTINUE
PRINT 49,AMAX,BMAX,CMAX
DO 206 J=1,100
BIN1(J)=BIN1(J)/AMAX
206 BIN2(J)=BIN2(J)/BMAX
BIN3(J)=BIN3(J)/CMAX
DO 46 K=1,12
46 ITITLE(K)=8H
ITITLE(1)=8HANDERSON
ITITLE(2)=8H BOX 263
ITITLE(7)=8H DENSITY
ITITLE(8)=8H FUNCTIO
ITITLE(9)=8HN X IN G
ITITLE(10)=8HAMMA Y
ITITLE(11)=8HIN FREQ
LABA=4H P1
LABB=4H P2
LABC=4H P3
CALL DRAW(100,X,BIN1,0,C,LABA,ITITLE,0,0,0,4,0,2,8,8,0,LAST)
CALL DRAW(100,X,BIN2,0,C,LABB,ITITLE,0,0,0,4,0,2,8,8,0,LAST)
CALL DRAW(100,X,BIN3,0,C,LABC,ITITLE,0,0,0,4,0,2,8,8,0,LAST)
506 N=NPTS
HONEAV=0.
HTWCAV=0.
HTHREAV=0.
DO 48 L=1,N
HONEAV=HONEAV+HCNE(L)
HTWCAV=HTWCAV+HTWO(L)
48 HTHREAV=HTHREAV+HTHRE(L)
SVO4 = N
HONEAV = HONEAV/SVO4
HTWCAV = HTWCAV/SVO4
HTHREAV = HTHREAV/SVO4
PRINT 49,HONEAV,HTWOAV,HTHREAV
49 FORMAT(3E20.7)
PRINT 27,NBLOC
27 FORMAT(I7)
HONEAV= (HONEAV +HTWOAV +HTHREAV)/3.
PRINT 26,HONEAV
26 FORMAT(E20.7)
WRITE TAPE 2, HCNE
WRITE TAPE 2, HTWO
WRITE TAPE 2, HTHRE
REWIND 2
DO 90 L = 1,N
HONE(L) = HONE(L) - HONEAV
HTWC(L) = HTWO(L) - HONEAV
90 HTHRE(L) = HTHRE(L) - HONEAV
DO 1 L=1,12
1 ITITLE(L) = 8H
ITITLE(1)=8HANDERSON
ITITLE(2)=8H BOX 263
ITITLE(7)=8H EARTHS
ITITLE(8)=8HMAGNETIC
ITITLE(9)=8H FIELD V
ITITLE(10)=8HS TIME
ITITLE(11)=8HT IN HRS
ITITLE(12)=8H H GAMMA
LABA=4H H1
LABB=4H H2
LABC=4H H3
CALL DRAW(N,T,HCNE,1,0,LABA,ITITLE,1.0,10.0,5,1,2,2,8,10,0,LAST)
CALL DRAW(N,T,HTWC,2,0,LABB,ITITLE,1.0,10.0,5,1,2,2,8,10,0,LAST)
CALL DRAW(N,T,HTHRE,3,0,LABC,ITITLE,1.0,10.0,5,1,2,2,8,10,0,LAST)
C Z TRANSFORM LOW PASS FILTER N EQUAL 20 TITUS
AT= 11.3 11.16/100

```

APPENDIX III

```

302 IF(J-20) 302,303,303
M=J
GO TO 304
303 M=20
304 DO 301 K=1,M
L= K-1
BL=L
ASUM = EXPF(-AT*PL)+ASUM
BSUM =EXPF(-AT*BL)*HONE(J-L)+BSUM
CSUM =EXPF(-AT*BL)*HTWO(J-L) + CSUM
301 DSUM = EXPF(-AT*BL)*HTHRE(J-L)+DSUM
HONE(J)=BSUM/ASUM
HTWO(J)= CSUM/ASUM
300 HTHRE(J)= DSUM/ASUM
ITITLE(2)=8H FILTER
CALL DRAW(N,T,HONE,1,0,LABA,ITITLE,1.0,10.0,5,1,2,2,8,10,0,LAST)
CALL DRAW(N,T,HTWO,2,0,LABB,ITITLE,1.0,10.0,5,1,2,2,8,10,0,LAST)
CALL DRAW(N,T,HTHRE,3,0,LABC,ITITLE,1.0,10.,5,1,2,2,8,10,0,LAST)
C DIFFERENCES OF FILTERED VALVES
DO 306 J = 1,N
H(J)= HONE(J)
HONE(J)= H(J)- HTWO(J)
STORE = HTWO(J)
HTWO(J)= H(J)-HTHRE(J)
306 HTHRE(J)= STORE- HTHRE(J)
ITITLE(7)=8H FILTERED
ITITLE(8)=8HDIFFEREN
ITITLE(9)=8HCE IN MA
ITITLE(10)=8HG FIELD
LABA=4HDEL1
LABB=4HDEL2
LABC=4HDEL3
CALL DRAW(N,T,HONE,1,0,LABA,ITITLE,1.0,5.00,5,1,2,2,8,10,0,LAST)
CALL DRAW(N,T,HTWO,2,0,LABB,ITITLE,1.0,5.00,5,1,2,2,8,10,0,LAST)
CALL DRAW(N,T,HTHRE,3,0,LABC,ITITLE,1.0,5.0,5,1,2,2,8,10,0,LAST)
C THIS SECTION COMPUTES SIMPLE DIFF
READ TAPE 2, HONE
READ TAPE 2, HTWO
READ TAPE 2, HTHRE
REWIND 2
DO 15 L=1,900
H(L)=HONE(L)
HONE(L)=H(L)-HTWC(L)
STORE=HTWO(L)
HTWO(L)=H(L)-HTHRE(L)
15 HTHRE(L)=STORE-HTHRE(L)
DO 16 L=1,12
16 ITITLE(L)=8H
ITITLE(1)=8HANDERSON
ITITLE(2)=8H BOX 263
ITITLE(7)=8HFIRST DI
ITITLE(8)=8HFFERENCE
ITITLE(9)=8H IN MAG
ITITLE(10)=8HFIELD
ITITLE(11)=8HT IN HRS
ITITLE(12)=8H H GAMMA
LABA=4HDEL1
LABB=4HDEL2
LABC=4HDEL3
CALL DRAW(N,T,HONE,1,0,LABA,ITITLE,1.0,5.00,5,1,2,2,8,10,0,LAST)
CALL DRAW(N,T,HTWO,2,0,LABB,ITITLE,1.0,5.00,5,1,2,2,8,10,0,LAST)
CALL DRAW(N,T,HTHRE,3,0,LABC,ITITLE,1.0,5.0,5,1,2,2,8,10,0,LAST)
C AUTOCORRELATION FUNCTION 75LAGS
NLAGS=75
MPTS= N-NLAGS
PTS= MPTS
XL=0.
DO 9 J=1,100
BIN1(J)=0.
BIN2(J)=0.
BIN3(J)=0.
X(J)=XL
9 XL = XL+1.
READ TAPE 2, HONE
READ TAPE 2, HTWO
READ TAPE 2, HTHRE
REWIND 2
DO 11 J=1,N
HONE(J) = HONE(J)- HONEAV
HTWO(J) = HTWO(J) - HTWCAV
11 HTHRE(J)=HTHRE(J)-HTHREAV
DO 12 J=1,NLAGS
DO 14 K=1,MPTS
L=K-1

```

APPENDIX III

```

BIN2(J)=BIN2(J)+HTWO(K)*HTWO(L+J)
14 BIN3(J)=BIN3(J)+HTHRE(K)*HTHRE(L+J)
BIN1(J)=BIN1(J)/PTS
BIN2(J)=BIN2(J)/PTS
12 BIN3(J)=BIN3(J)/PTS
C SAVE AUTOCORRELATION FUNCTION
DO 105 J=1,100
H(J)=BIN1(J)
H(J+100)=BIN2(J)
105 H(J+200)=BIN3(J)
DO 100 J=1,12
100 ITITLE(J)=8H
ITITLE(1)=8HANDERSON
ITITLE(2)=8H BOX 263
ITITLE(7)=8HAUTOCORR
ITITLE(8)=8HELATION
ITITLE(9)=8HFUNCTION
ITITLE(10)=8H Y IN PR
ITITLE(11)=8HODUCTS X
ITITLE(12)=8H IN LAGS
LABA=4H H1
LABB=4H H2
LABC=4H H3
CALL DRAW(NLAGS,X,BIN1,1,0,LABA,ITITLE,0,0,0,0,0,0,8,8,0,LAST)
CALL DRAW(NLAGS,X,BIN2,2,0,LABB,ITITLE,0,0,0,0,0,0,8,8,0,LAST)
CALL DRAW(NLAGS,X,BIN3,3,0,LABC,ITITLE,0,0,0,0,0,0,8,8,0,LAST)
C CROSS CORRELATION FUNCTION 75 LAGS
DO 101 J=1,100
BIN1(J)=0.
BIN2(J)=0.
101 BIN3(J)=0.
DO 102 J=1,NLAGS
DO 103 K=1,MPTS
L=K-1
BIN1(J)=8BIN1(J)+HTWO(K)*HONE(L+J)
BIN2(J)=BIN2(J)+HTWO(K)*HTHRE(L+J)
103 BIN3(J)=BIN3(J)+HONE(K)*HTHRE(L+J)
BIN1(J)=BIN1(J)/PTS
BIN2(J)=BIN2(J)/PTS
102 BIN3(J)=BIN3(J)/PTS
DO 104 J=1,12
104 ITITLE(J)=8H
ITITLE(1)=8HANDERSON
ITITLE(2)=8H BOX 263
ITITLE(7)=8HCROSCORR
ITITLE(8)=8HELATION
ITITLE(9)=8HFUNCTION
ITITLE(10)=8H Y IN PR
ITITLE(11)=8HODUCTS X
ITITLE(12)=8H IN LAGS
LABA=4H H21
LABB=4H H23
LABC=4H H13
CALL DRAW(NLAGS,X,BIN1,1,0,LABA,ITITLE,0,0,0,0,0,0,8,8,0,LAST)
CALL DRAW(NLAGS,X,BIN2,2,0,LABB,ITITLE,0,0,0,0,0,0,8,8,0,LAST)
CALL DRAW(NLAGS,X,BIN3,3,0,LABC,ITITLE,0,0,0,0,0,0,8,8,0,LAST)
C COHERENCY COMPUTATION 75 LAGS
DO 106 J=1,NLAGS
BIN1(J)=(BIN1(J)**2)/(H(J+100)*H(J))
107 IF(BIN1(J)) 107,108,108
108 BIN1(J)=SQRTF(BIN1(J))
BIN2(J)=(BIN2(J)**2)/(H(J+100)*H(J+200))
109 IF(BIN2(J)) 109,110,110
110 BIN2(J)=SQRTF(BIN2(J))
BIN3(J)=(BIN3(J)**2)/(H(J)*H(J+200))
111 IF(BIN3(J)) 111,106,106
106 BIN3(J)=SQRTF(BIN3(J))
ITITLE(7)=8HCOHERENC
ITITLE(8)=8HE
ITITLE(10)=8H Y IN CO
ITITLE(11)=8H X IN L
ITITLE(12)=8HAGS
CALL DRAW(NLAGS,X,BIN1,1,0,LABA,ITITLE,0,.2,0,0,0,0,8,8,0,LAST)
CALL DRAW(NLAGS,X,BIN2,2,0,LABB,ITITLE,0,.2,0,0,0,0,8,8,0,LAST)
CALL DRAW(NLAGS,X,BIN3,3,0,LABC,ITITLE,0,.2,0,0,0,0,8,8,0,LAST)
70 CONTINUE
REWIND 3
STOP
END
MACHINE READ(1ARG,2ARG,3ARG,4ARG)

```

APPENDIX III

* TYPEWRITER MESSAGE CODE TABLE

```

CON(T6 =4504041220302204B, T7 =1120061301050420B,
*   T8 =1212031200000000CB, T9 =4504041220302204B,
*   T10=1530121401250420B, T11=1212031200000000CB)
CON(T12=4504041220302204B, T13=2006220403260426B,
*   T14=1411200000000000CB, T15=4504043112140120B,
*   T40=4504040130152004B, T41=3406140104060301B,
*   T42=0414062214163001B, T43=2022420000000000CB)
    
```

* TAPE UNIT ASSIGNMENT TABLE
 * ASSIGNMENTS FOR CHANNEL 3/4 LIBRARY TAPE

```

CON(K0 =0, K1 =332010B, K2 =332020B,
*   K3 =332030B, K4 =332040B, K5 =552010B,
*   K6 =552020B, K7 =552030B, K8 =552040B)
    
```

* ASSORTED CONSTANTS

```

CON(R4 =73737373737373B, R16=0070CC0CC0000000B)
    
```

* TAPE READING ROUTINE

1X	SLJ(N)	SLJ(L+5)	• EXIT/ENTRY
1ARG	ZRO(0)	ZRO(0)	• TAPE UNIT NUMBER ARG.
2ARG	ZRO(0)	ZRO(0)	• INITIAL ADDRESS
3ARG	ZRO(0)	ZRO(0)	• TERMINAL ADDRESS
4ARG	ZRO(0)	ZRO(0)	• MODE, 1 = BINARY, 2 = BCD
	LDA7(1ARG)	INA(-11B)	•
	SIU1(19X)	AJP3(L+3)	• CHECK FOR TU ASSIGNMENT
	ENA(T40)	SLJ4(G)	• GO PRINT ERROR
	SLJ(P)	ZRO(0)	•
	INA(11B)	STA(K0)	•
	LIL1(K0)	LDA1(K0)	•
	ADD7(4ARG)	SAU(4X)	• SET TU CONTROL CODES
	SCL(777B)	SAL(4X)	• INITIALIZE
	SAL(5X)	SAL(11X)	•
	INA(3)	SAU(8X)	•
	INA(2)	SAU(9X)	•
	INA(1)	SAU(11X)	•
	INA(1)	SAU(7X)	•
	LRS(18)	ENA(0)	•
	LLS(3)	SAL(2X)	•
	SAL(3X)	SAU(12X)	•
	LLS(39)	LDQ(R16)	•
	STA(K0)	LDA(5X)	•
	SSU(K0)	STA(5X)	•
	LDA7(2ARG)	SAU(5X)	•
	LDA(6X)	SSU(K0)	•
	STA(6X)	ENI(0)	•
2X	LDA7(3ARG)	SAL(N)	•
	SAU(6X)	SIL2(19X)	•
3X	ENI2(4)	LIL1(N)	•
4X	EXF(N)	EXF7(N)	• SELECT UNIT
5X	EXF(N)	EXF7(N)	• ACTIVATE CHANNEL
6X	EXF(N)	LDA7(2ARG)	•
	SUB(R4)	LLS(48)	•
	INI1(-1)	LDA1(Z)	•
	INI1(1)	SUB(R4)	•
7X	EXF7(N)	SLJ(15X)	• SENSE ENDFILE
8X	EXF7(N)	SLJ(L+4)	• SENSE PARITY ERROR
9X	EXF7(N)	SLJ(10X)	• SENSE LENGTH ERROR
	QJP1(19X)	AJP(3X)	• SENSE FOR BAD RECORD
	SLJ(19X)	ZRO(0)	• EXIT
	IJP2(L+2)	SLJ(14X)	• SENSE FIVE PARITY ERRORS
10X	IJP2(L+1)	SLJ(13X)	• SENSE FIVE LENGTH ERRORS
	AJP(3X)	QJP(3X)	• SENSE FOR BAD RECORD
11X	EXF(N)	EXF7(N)	• BACKSPACE
12X	LIL1(N)	SLJ(4X)	• RETURN TO REREAD
13X	ENA(T6)	SLJ(17X)	• SET TO INDICATE TROUBLE
14X	ENA(T9)	SLJ(17X)	•
15X	ENA(T12)	SLJ(18X)	•
17X	SLJ4(G)	ZRO(0)	• TROUBLE EXIT
	AJP(19X)	AJP3(3X)	• SENSE ACTION TO TAKE
	SLJ(11X)	ZRO(0)	•
18X	SLJ4(G)	ZRO(0)	• TROUBLE EXIT
	AJP(3X)	AJP3(3X)	• SENSE ACTION TO TAKE
	SLJ(11X)	ZRO(0)	•
19X	ENI1(N)	ENI2(N)	• RE-STORE INDEXES
	SLJ(1X)	ZRO(0)	•

```

PROGRAM PROMAG
DIMENSION NDATA(864),DATE(100),H(1728),HONE(900),ITITLE(12),
1HTWO(900),HTHRE(900),T(900)
DO 5 J = 1,14
READ 5,DATE(J)
5 FORMAT(016)
CON(MASK = 0000000077777777B)
ENA(NDATA),INA(1).
STA(INIT),INA(864).
STA(ITERM),ENI(0).
6 CALL READ(3,INIT,ITERM,1)
DO 70 I = 1,11,2
ADATE = DATE(I)
BDATE = DATE(I+1)
LDA(ADATE),SUB(NDATA +1),AJP1(6),
LDA(BDATE),SUB(NDATA +2),AJP1(6).
NBLOC = 0
30 CALL READ(3,INIT,ITERM,1)
ND = NDATA(3)
LDA(ND),AJPO(10).
K=0
DO 40 J=1,864
K=K+1
INDATA = NDATA(J)
LDA(INDATA),LDQ(MASK),ARS(24),STL(INLIST).
H(K)=INLIST
K=K+1
LDA(INDATA),LDQ(MASK),STL(INLIST).
SLS1(40).
40 H(K)=INLIST
AVE=0.
DO 50 J =1,1728
H(J)=(1024./H(J))*2348400.0
50 AVE=H(J)+AVE
AVE=AVE/1728.
PRINT 26, AVE
C ZAPP FILTER
NERR = 0
AVE = 0.
HBAR = 50950.0
DO 51 J=1,1728
DEV = ABSF(H(J)-HBAR)
IF(DEV-200.) 51,52,52
52 NERR = NERR + 1
IF(J-3) 53,53,54
53 H(J) = H(J+3)
GO TO 51
54 H(J) = H(J-3)
51 AVE = AVE + H(J)
AVE = AVE/1728.
PRINT 26, AVE
PRINT 27, NERR
NBLOC = NBLOC + 1
WRITE TAPE 2, H
GO TO 30
10 REWIND 2
NPTS = (1728*NBLOC)/2700
PRINT 27,NPTS
READ TAPE 2, H
K = 1
TIME = -6.5/900.
M=1
C THIS SECTION COMPUTES H VS TIME
DO 60 L=1,900
HONE(L)=(H(K)+H(K+3)+H(K+6))/3.
HTWO(L)=(H(K+1)+H(K+4)+H(K+7))/3.
LCOUNT=L
HTHRE(L)=(H(K+2)+H(K+5)+H(K+8))/3.
TIME = TIME + 6.5/900.
T(L) = TIME
K = K + 3*NPTS
MAX = K+8
IF(MAX - 1728) 60,60,80
80 K=1
IF(M-NBLOC) 85,95,95
85 READ TAPE 2,H
M=M+1
60 CONTINUE
95 PRINT 97,LCOUNT
PRINT 97,M
AT = 3.*5.1416/100.
REWIND 2
WRITE TAPE 2, HONE
WRITE TAPE 2, HTWO
WRITE TAPE 2, HTHRE

```

```

HONEAV=0.
HTWOAV=0.
HTHREAV=0.
DO 48 L=1,900
HONEAV=HONEAV+HONE(L)
HTWOAV=HTWOAV+HTWO(L)
48 HTHREAV=HTHREAV+HTHRE(L)
HONEAV=HONEAV/900.
HTWOAV=HTWOAV/900.
HTHREAV=HTHREAV/900.
PRINT 49,HONEAV,HTWOAV,HTHREAV
49 FORMAT(3E20.7)
PRINT 27,NBLOC
27 FORMAT(I7)
HONEAV=(HONEAV+HTWOAV+HTHREAV)/3.
PRINT 26,HONEAV
26 FORMAT(E20.7)
DO 90 L=1,900
HONE(L)=HONE(L)-HONEAV
HTWO(L)=HTWO(L)-HONEAV
90 HTHRE(L)=HTHRE(L)-HONEAV
DO 1 L=1,12
1 ITITLE(L)=8H
ITITLE(1)=8HANDERSON
ITITLE(2)=8H BOX 263
ITITLE(7)=8H EARTHS
ITITLE(8)=8HMAGNETIC
ITITLE(9)=8H FIELD V
ITITLE(10)=8HS TIME
ITITLE(11)=8HT IN HRS
ITITLE(12)=8H H GAMMA
LABA=4H H1
LABB=4H H2
LABC=4H H3
CALL DRAW(900,T,HONE,1,0,LABA,ITITLE,1.0,10.0,5,1,2,2,8,10,0,LAST)
CALL DRAW(900,T,HTWO,2,0,LABB,ITITLE,1.0,10.0,5,1,2,2,8,10,0,LAST)
CALL DRAW(900,T,HTHRE,3,0,LABC,ITITLE,1.0,10.0,5,1,2,2,8,10,0,LAST)
CALL SATGRAF(0,900,T,HONE,0,0,0,0)
CALL SATGRAF(0,900,T,HTWO,0,0,0,0)
CALL SATGRAF(0,900,T,HTHRE,0,0,0,0)
C THIS SECTION COMPUTES SIMPLE DIFF
READ TAPE 2, HONE
READ TAPE 2, HTWO
READ TAPE 2, HTHRE
REWIND 2
DO 15 L=1,900
H(L)=HONE(L)
HONE(L)=H(L)-HTWO(L)
STORE=HTWO(L)
HTWO(L)=H(L)-HTHRE(L)
15 HTHRE(L)=STORE-HTHRE(L)
DO 16 L=1,12
16 ITITLE(L)=8H
ITITLE(1)=8HANDERSON
ITITLE(2)=8H BOX 263
ITITLE(7)=8HFIRST DI
ITITLE(8)=8HFFERENCE
ITITLE(9)=8H IN MAG
ITITLE(10)=8HFIELD
ITITLE(11)=8HT IN HRS
ITITLE(12)=8H H GAMMA
LABA=4HDEL1
LABB=4HDEL2
LABC=4HDEL3
CALL DRAW(900,T,HONE,1,0,LABA,ITITLE,1.0,2.00,5,1,2,2,8,10,0,LAST)
CALL DRAW(900,T,HTWO,2,0,LABB,ITITLE,1.0,2.00,5,1,2,2,8,10,0,LAST)
CALL DRAW(900,T,HTHRE,3,0,LABC,ITITLE,1.0,2.0,5,1,2,2,8,10,0,LAST)
CALL SATGRAF(0,900,T,HONE,0,0,0,0)
CALL SATGRAF(0,900,T,HTWO,0,0,0,0)
CALL SATGRAF(0,900,T,HTHRE,0,0,0,0)
70 CONTINUE
REWIND 3
STOP
END
MACHINE READ(1ARG,2ARG,3ARG,4ARG)

```

* NOTE G = ADDRESS OF ENTRY TO TYPEWRITER SENSE ROUTINE
 * P = ADDRESS OF PROGRAM CONTROL ROUTINE JUMP ENTRY
 * THIS ROUTINE IS FOR PROGRAM CALL

LOC(G=31, P=10)

III-8

* TYPEWRITER MESSAGE CODE TABLE

```

CON(T12=4504041220302204B, T13=2006220403260426B,
* T14=1411200000000000B, T15=4504043112140120B,
* T40=4504040130152004B, T41=3406140104060301B,
* T42=0414062214163001B, T43=2022420000000000B)

```

* TAPE UNIT ASSIGNMENT TABLE
* ASSIGNMENTS FOR CHANNEL 3/4 LIBRARY TAPE

```

CON(K0 =0, K1 =332010B, K2 =332020B,
* K3 =332030B, K4 =332040B, K5 =552010B,
* K6 =552020B, K7 =552030B, K8 =552040B)

```

* ASSORTED CONSTANTS

```

CON(R4 =7373737373737373B, R16=0070000000000000B)

```

* TAPE READING ROUTINE

```

1X SLJ(N) SLJ(L+5) . EXIT/ENTRY
1ARG ZRO(0) ZRO(0) . TAPE UNIT NUMBER ARG.
2ARG ZRO(0) ZRO(0) . INITIAL ADDRESS
3ARG ZRO(0) ZRO(0) . TERMINAL ADDRESS
4ARG ZRO(0) ZRO(0) . MODE, 1 = BINARY, 2 = BCD
LDA7(1ARG) INA(-11B) .
SIU1(19X) AJP3(L+3) . CHECK FOR TU ASSIGNMENT
ENA(T40) SLJ4(G) . GO PRINT ERROR
SLJ(P) ZRO(0) .
INA(11B) STA(K0) .
LIL1(K0) LDA1(K0) .
ADD7(4ARG) SAU(4X) . SET TU CONTROL CODES
SCL(777B) SAL(4X) . INITIALIZE
SAL(5X) SAL(11X) .
INA(3) SAU(8X) .
INA(2) SAU(9X) .
INA(1) SAU(11X) .
INA(1) SAU(7X) .
LRS(18) ENA(0) .
LLS(3) SAL(2X) .
SAL(3X) SAU(12X) .
LLS(39) LDQ(R16) .
STA(K0) LDA(5X) .
SSU(K0) STA(5X) .
LDA7(2ARG) SAU(5X) .
LDA(6X) SSU(K0) .
STA(6X) ENI(0) .
2X LDA7(3ARG) SAL(N) .
SAU(6X) SIL2(19X) .
3X ENI2(4) LIL1(N) .
4X EXF(N) EXF7(N) . SELECT UNIT
5X EXF(N) EXF7(N) . ACTIVATE CHANNEL
6X EXF(N) LDA7(2ARG) .
SUB(R4) LLS(48) .
INI1(-1) LDA1(Z) .
INI1(1) SUB(R4) .
7X EXF7(N) SLJ(15X) . SENSE ENDFILE
8X EXF7(N) SLJ(L+4) . SENSE PARITY ERROR
9X EXF7(N) SLJ(10X) . SENSE LENGTH ERROR
QJP1(19X) AJP(3X) . SENSE FOR BAD RECORD
SLJ(19X) ZRO(0) . EXIT
IJP2(L+2) SLJ(14X) . SENSE FIVE PARITY ERRORS
10X IJP2(L+1) SLJ(13X) . SENSE FIVE LENGTH ERRORS
AJP(3X) QJP(3X) . SENSE FOR BAD RECORD
11X EXF(N) EXF7(N) . BACKSPACE
12X LIL1(N) SLJ(4X) . RETURN TO REREAD
13X ENA(T6) SLJ(17X) . SET TO INDICATE TROUBLE
14X ENA(T9) SLJ(17X) .
15X ENA(T12) SLJ(18X) .
17X SLJ4(G) ZRO(0) . TROUBLE EXIT
AJP(19X) AJP3(3X) . SENSE ACTION TO TAKE
SLJ(11X) ZRO(0) .
18X SLJ4(G) ZRO(0) . TROUBLE EXIT
AJP(3X) AJP3(3X) . SENSE ACTION TO TAKE
SLJ(11X) ZRO(0) .
19X ENI1(N) ENI2(N) . RE-STORE INDEXES
SLJ(1X) ZRO(0) .
END
END

```

```

.5143083E+05
.5093095E+05

```

```

.5097462E+05

```

APPENDIX IV

<u>CIRCUIT DIAGRAMS</u>	<u>PAGE</u>
POLARIZING AND DAMPING NETWORK	1
MAGNETOMETER PREAMP	2
MAGNETOMETER AMPLIFIER	3
RADAR GATE	4
CLOCK GATE AND GATE CONTROL	5
STORAGE RESET AND GATE DRIVER	6
TIMER	7
COUNTER START AND RESET	8
SIGNAL GATE AND GATE CONTROL	9
CLOCK FREQUENCY MULTIPLIER	10
COUNTER FLIP-FLOP AND GATE	11
MULTIPLEX PULSE GENERATOR	12
MULTIPLEX BLOCK DIAGRAM	13
ANALOG LADDER	14
OUTPUT AMPLIFIERS	15
PLUS AND MINUS 1.2 VOLT POWER SUPPLY	16
PLUS AND MINUS 4 VOLT POWER SUPPLY	17
PLUS 28 VOLT OSCILLATOR AND TIMER POWER SUPPLY	18
INTERFACE DRIVER AND AMPLIFIER	19
INTERFACE AND/OR GATES	20
INTERFACE FLIP-FLOP AND INVERTER	21

APPENDIX IV

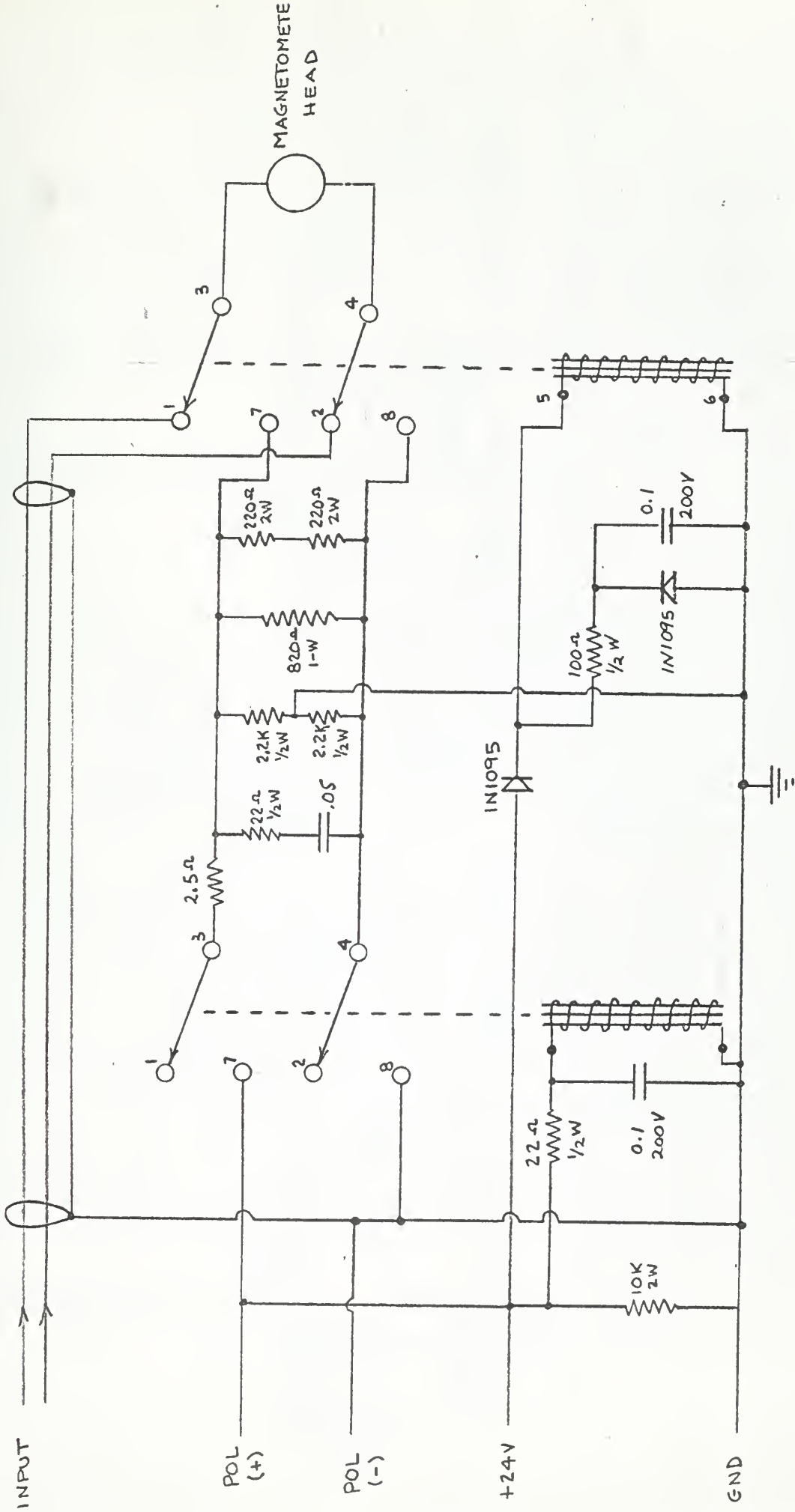

IV-1

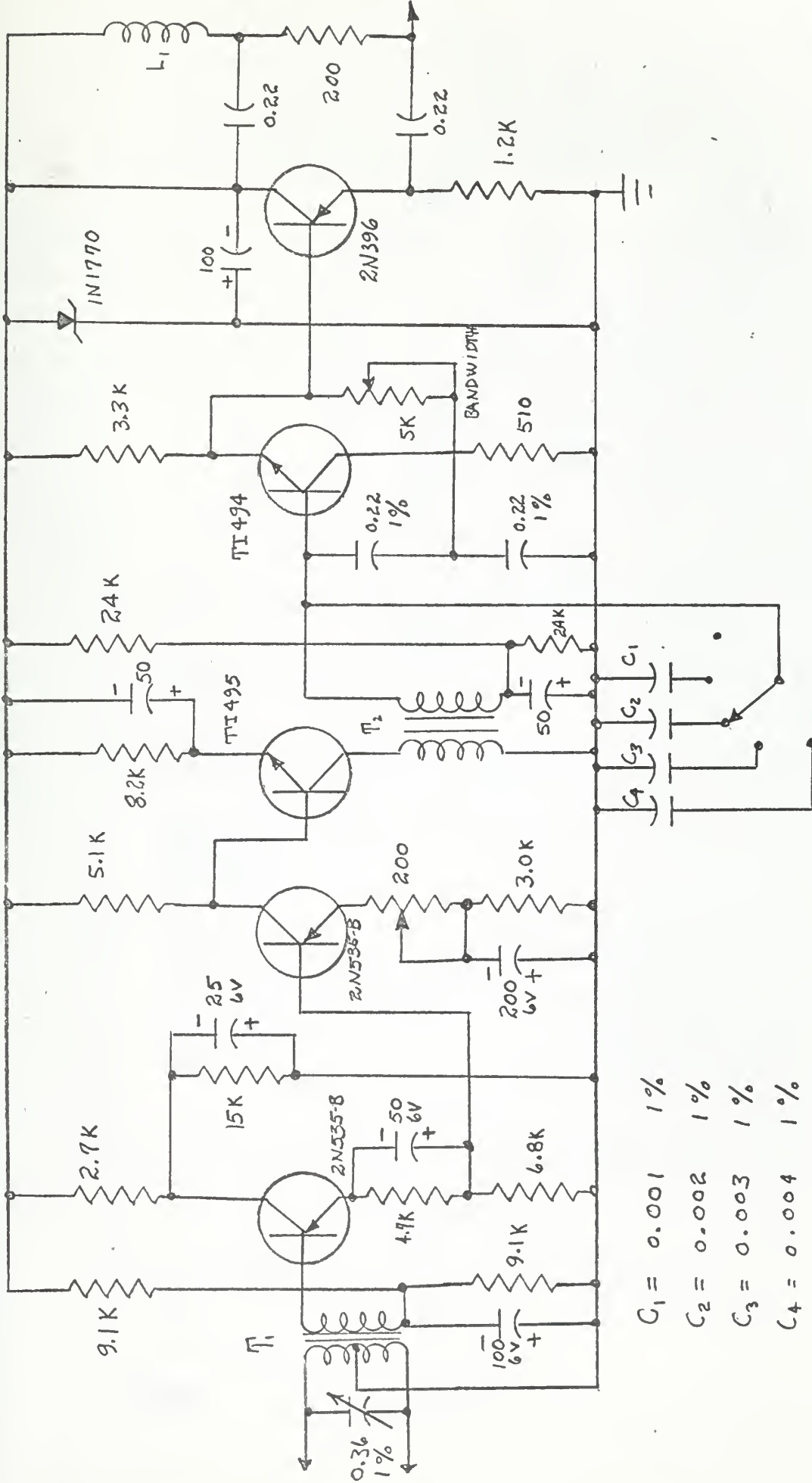

- $C_1 = 0.001 \quad 1\%$
- $C_2 = 0.002 \quad 1\%$
- $C_3 = 0.003 \quad 1\%$
- $C_4 = 0.004 \quad 1\%$

$L_1 = 24.4 \text{ mh}$

$T_1 = 400T \text{ (PRIMARY)}$
 $1400T \text{ (SECONDARY)}$

$T_2 = 120T \text{ (PRIMARY)}$
 $570T \text{ (SECONDARY)}$

APPENDIX IV

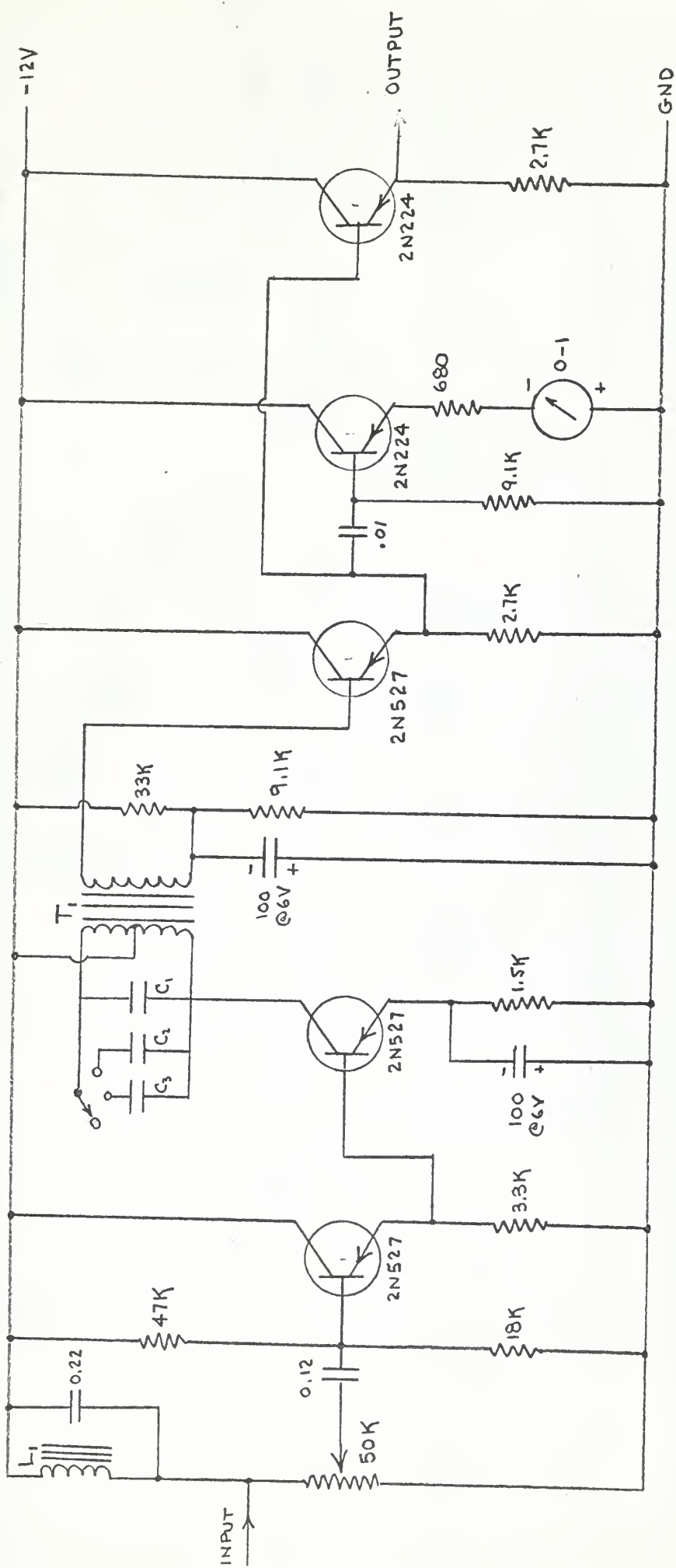

APPENDIX IV

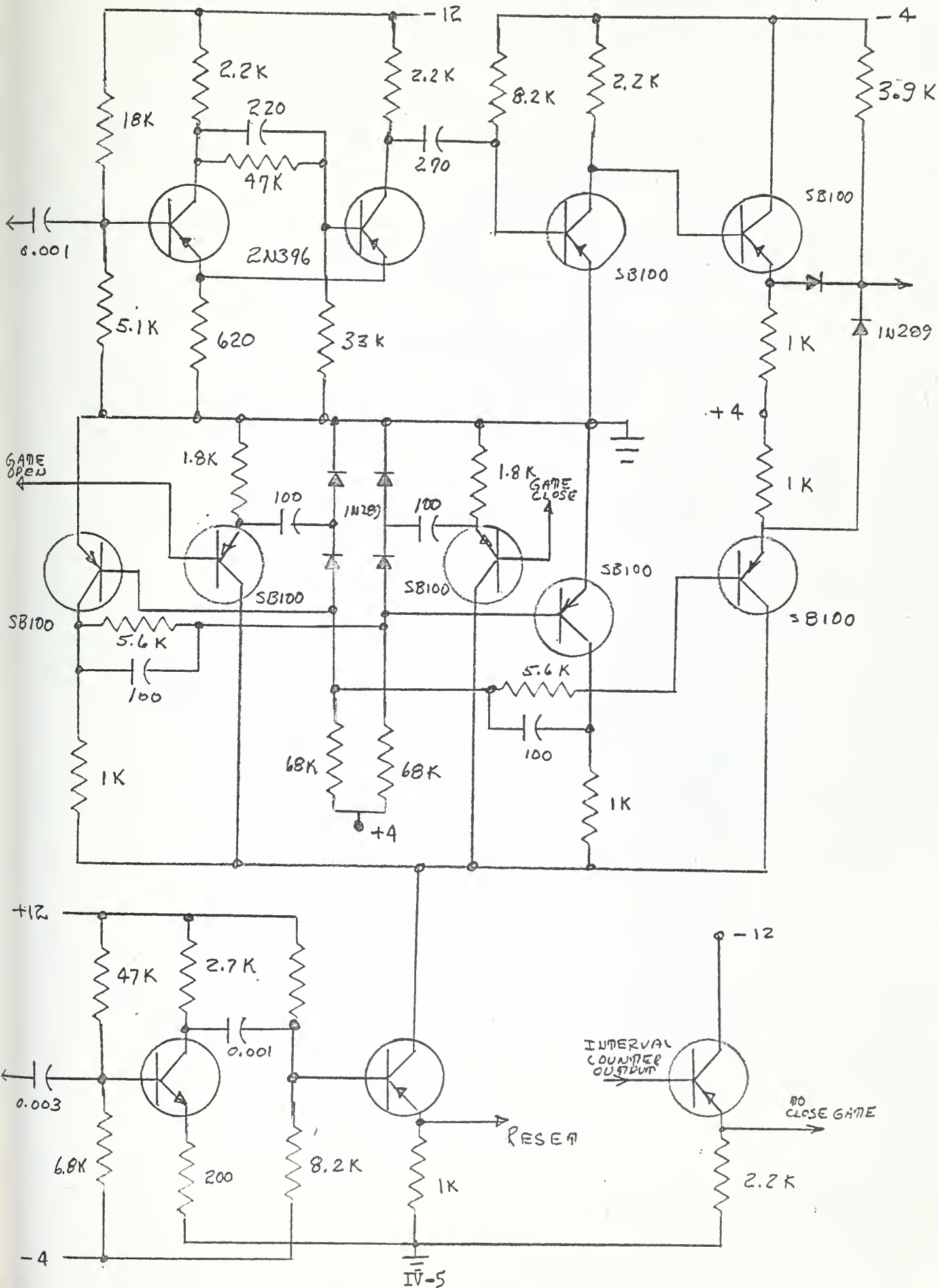

APPENDIX IV

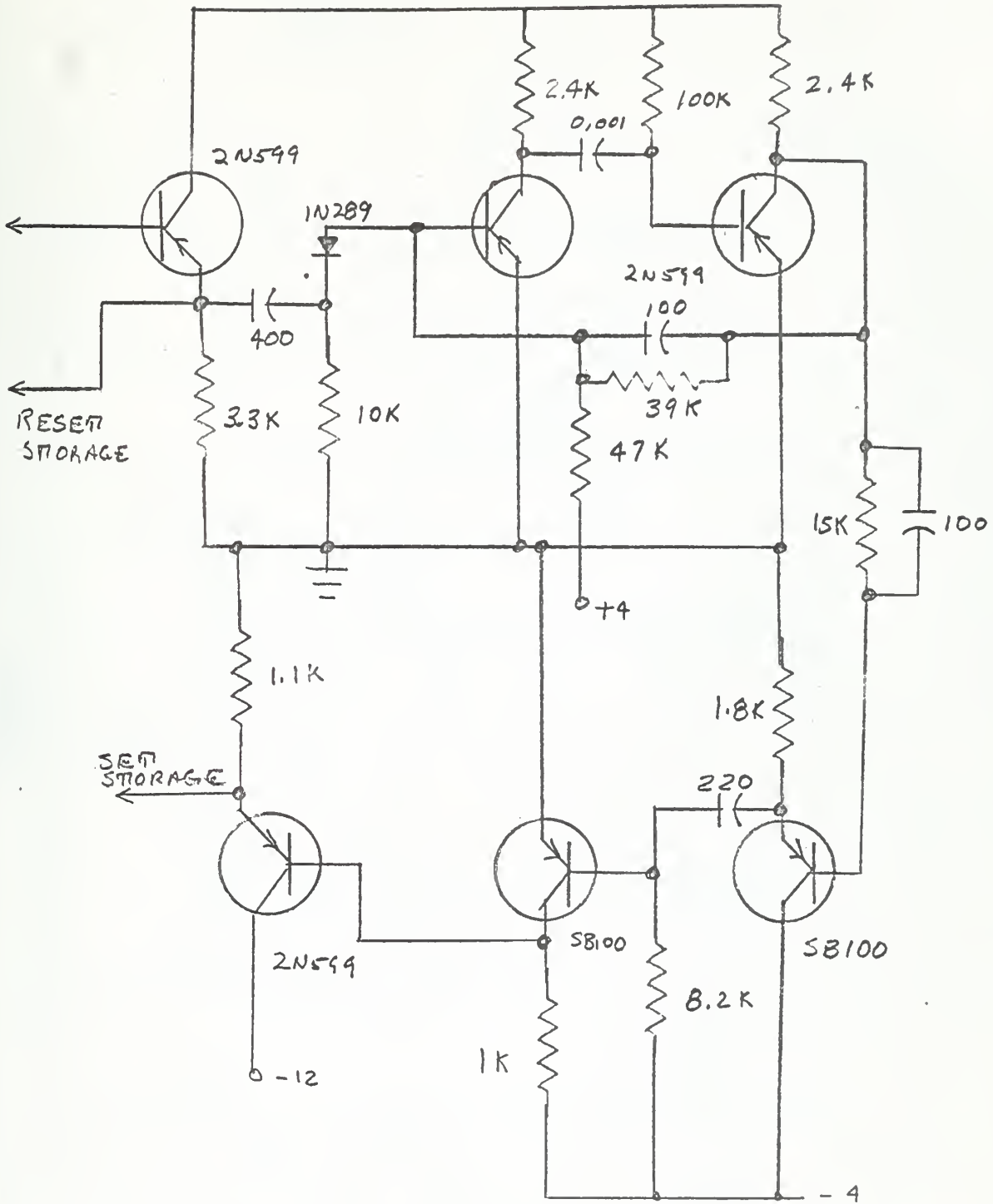

APPENDIX IV

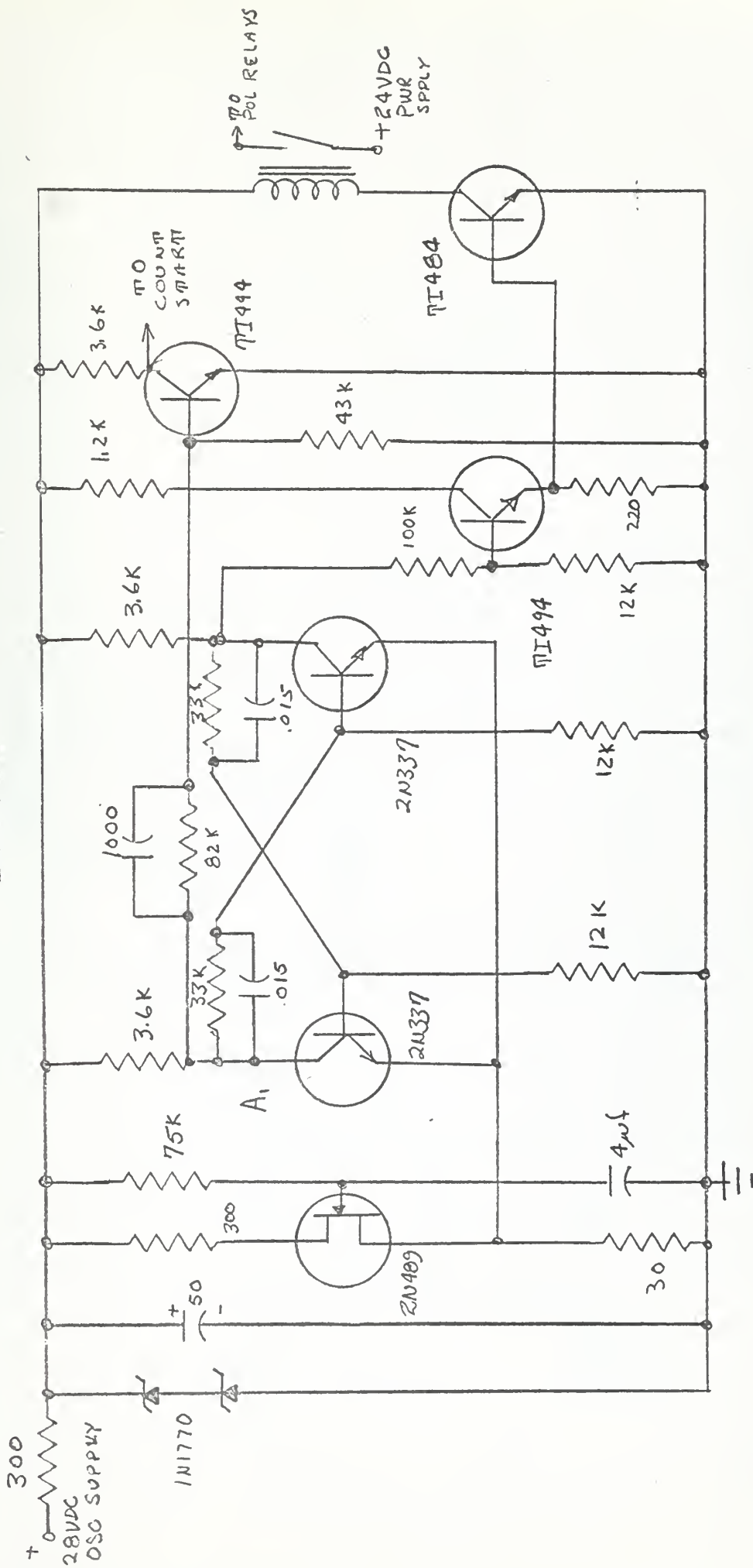

APPENDIX IV

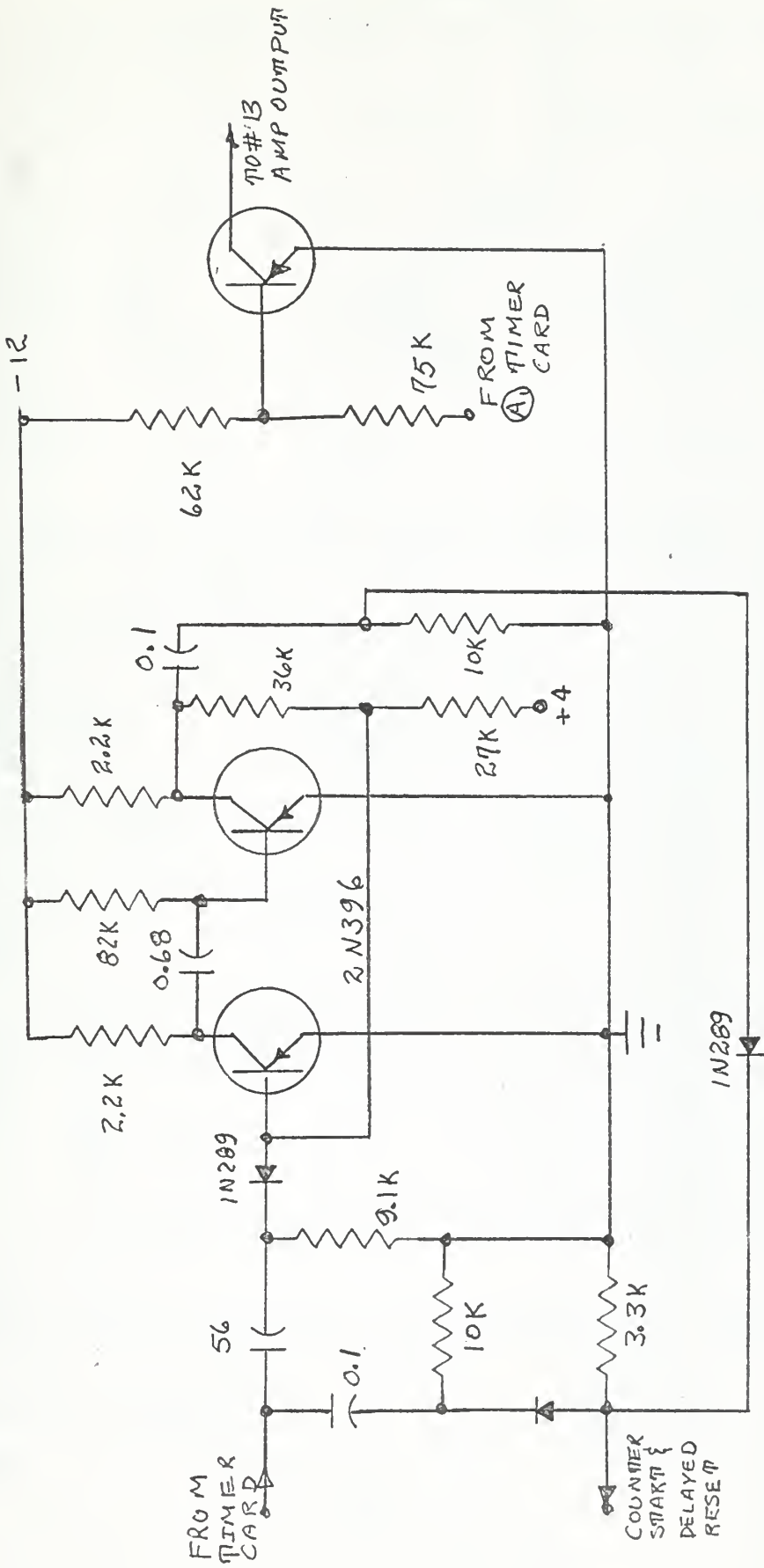

APPENDIX IV

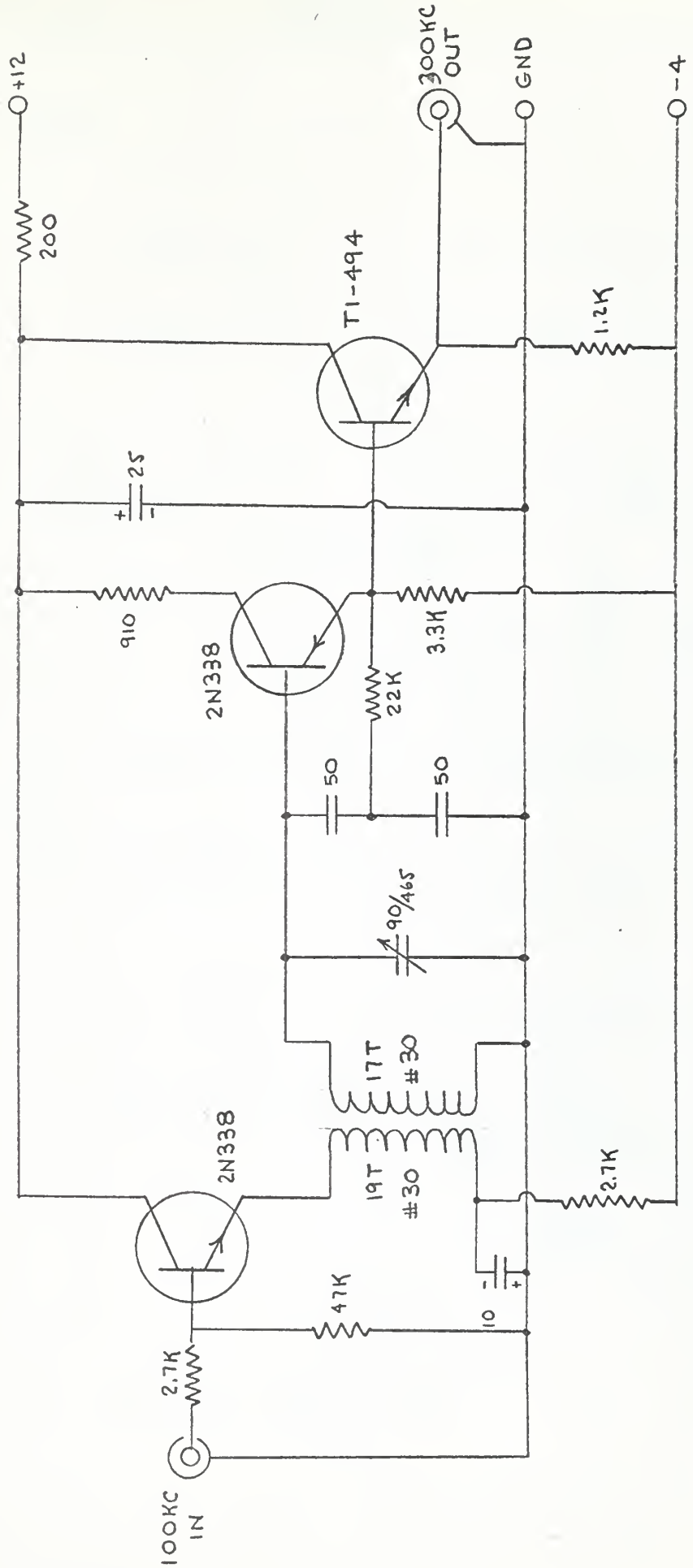

APPENDIX IV

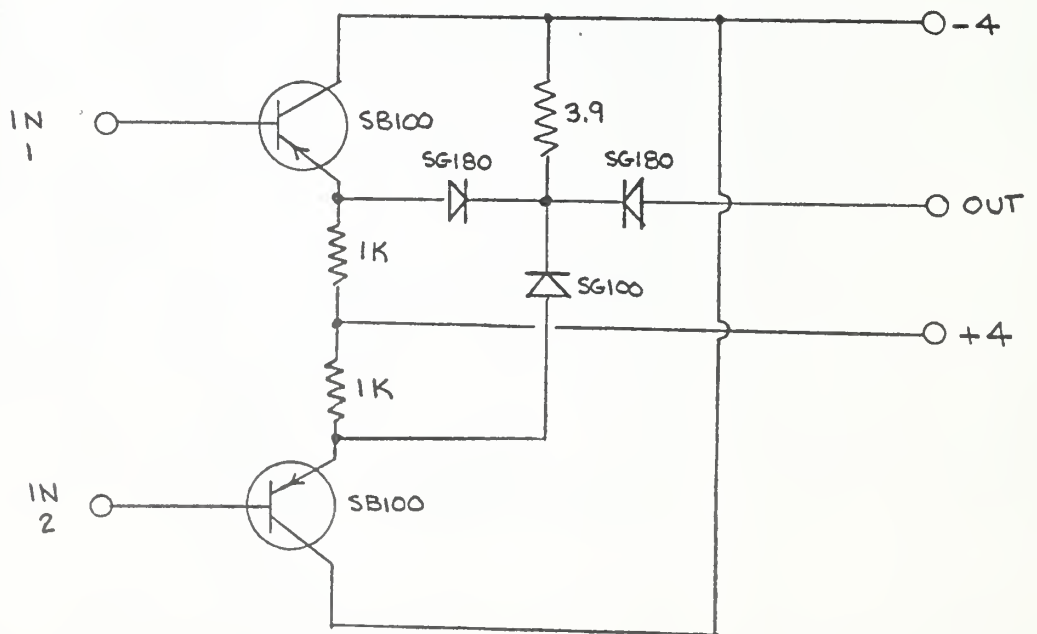
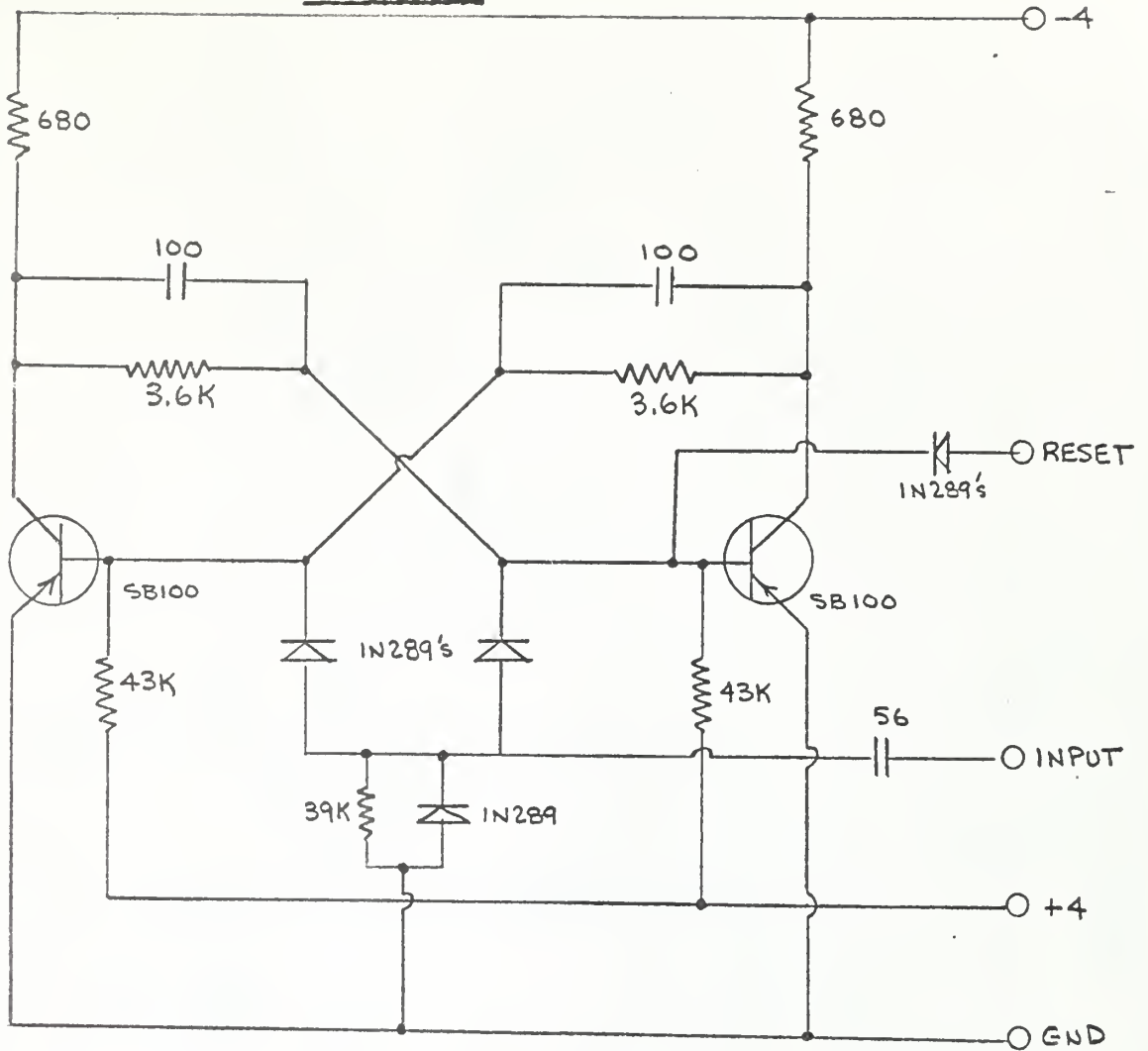

APPENDIX IV

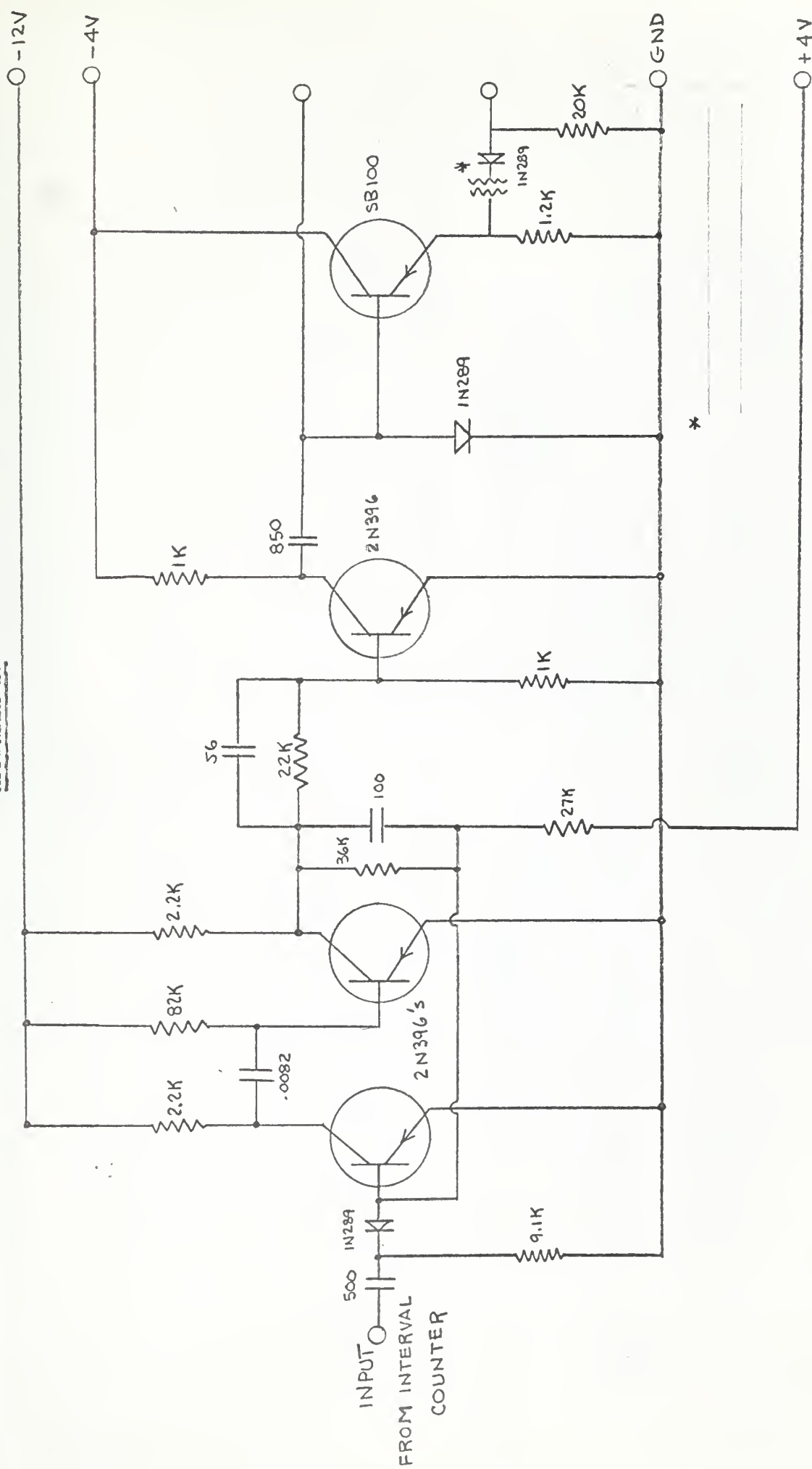

APPENDIX IV

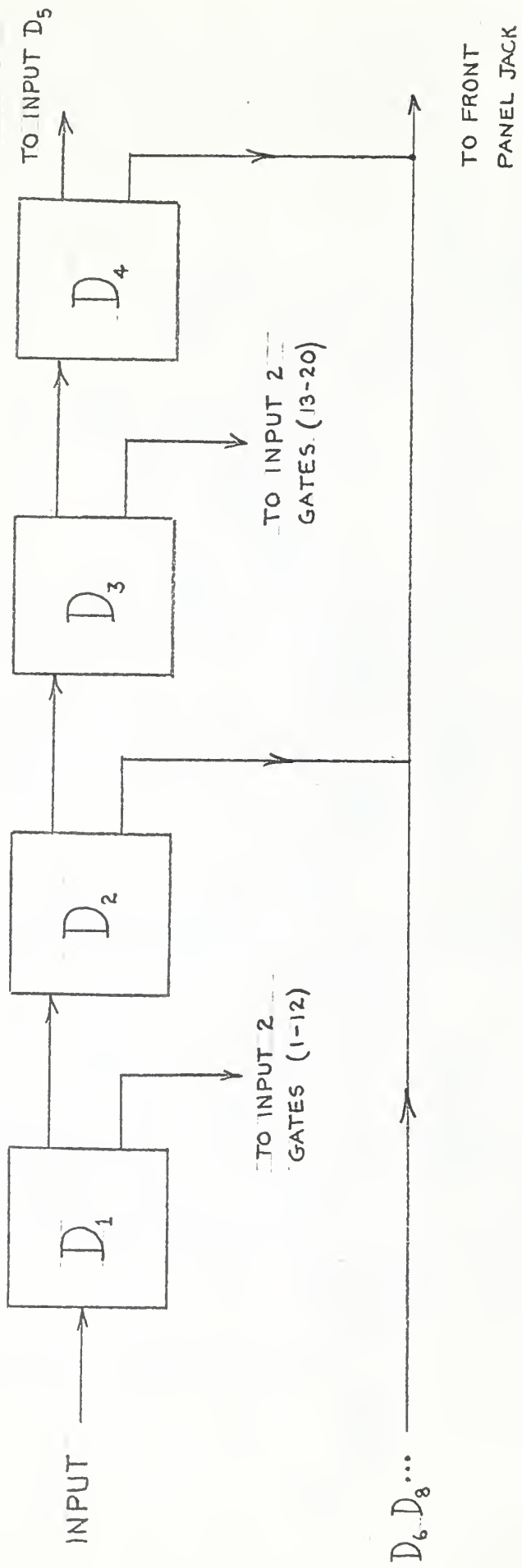

APPENDIX IV

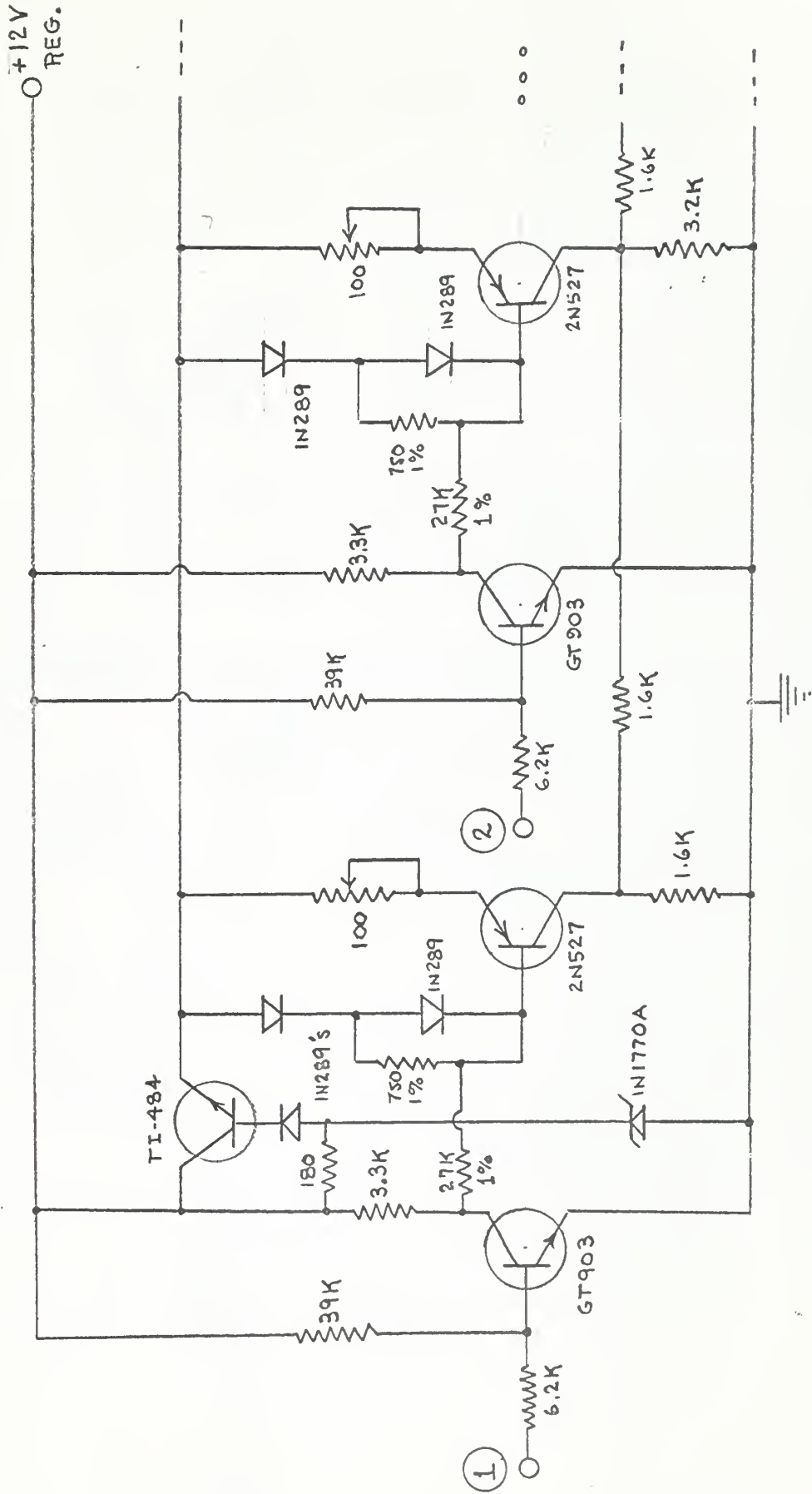

APPENDIX IV

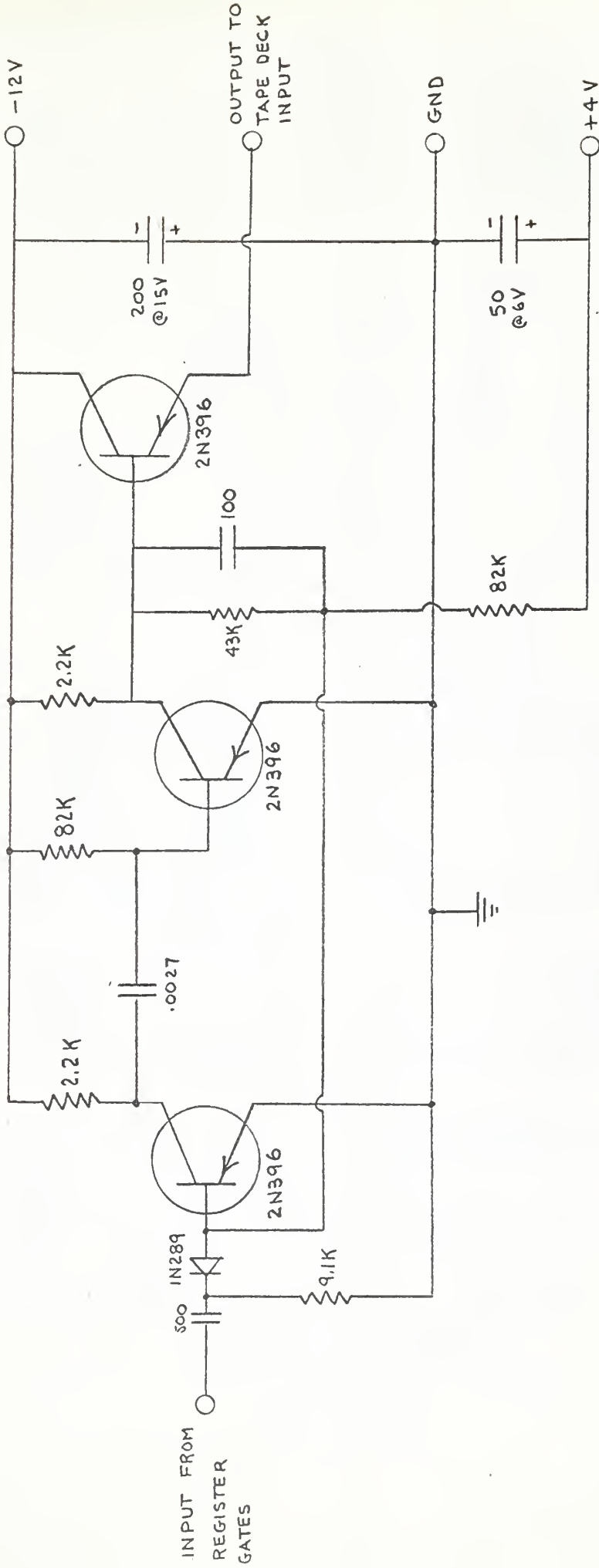

APPENDIX IV

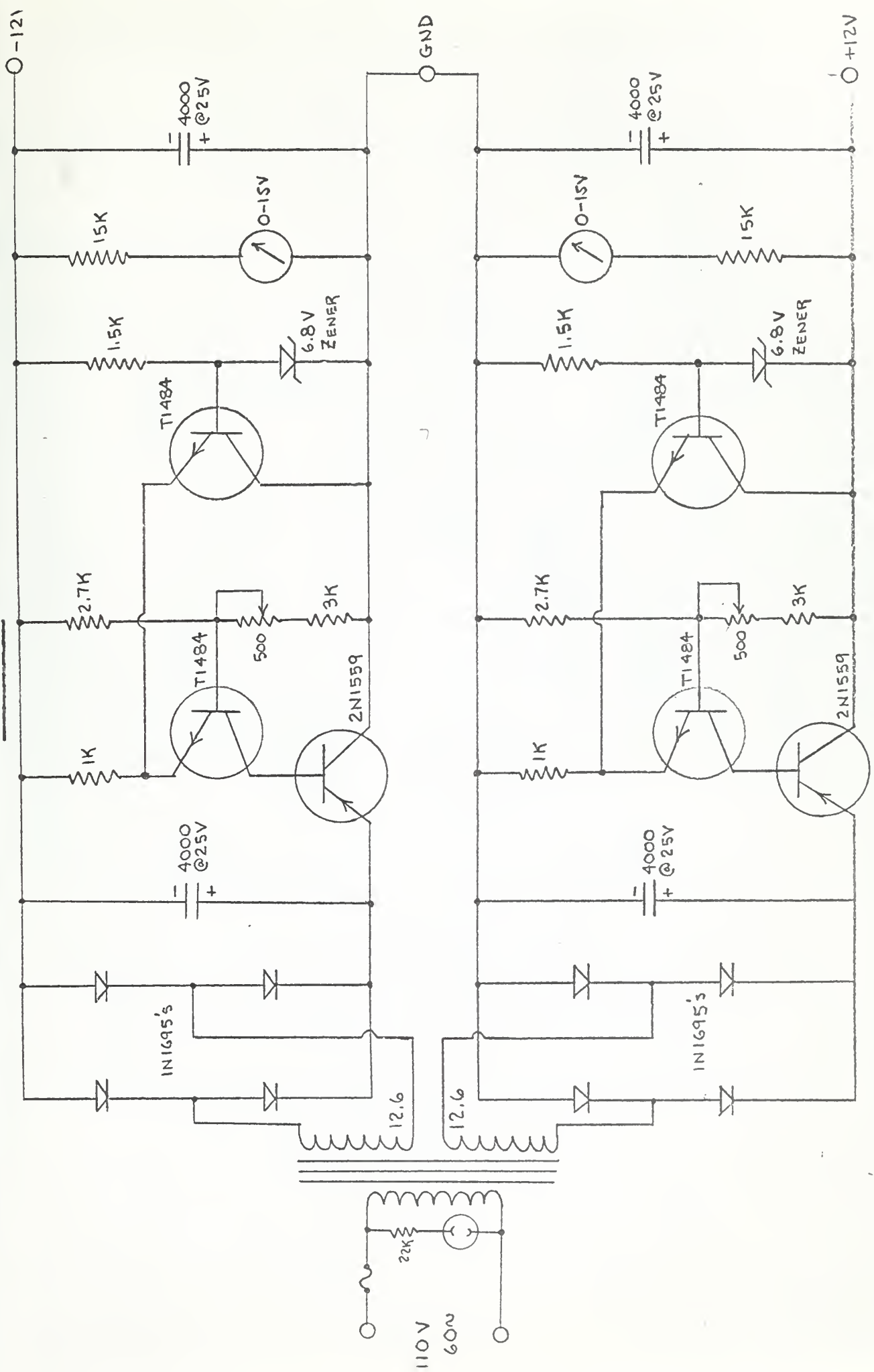

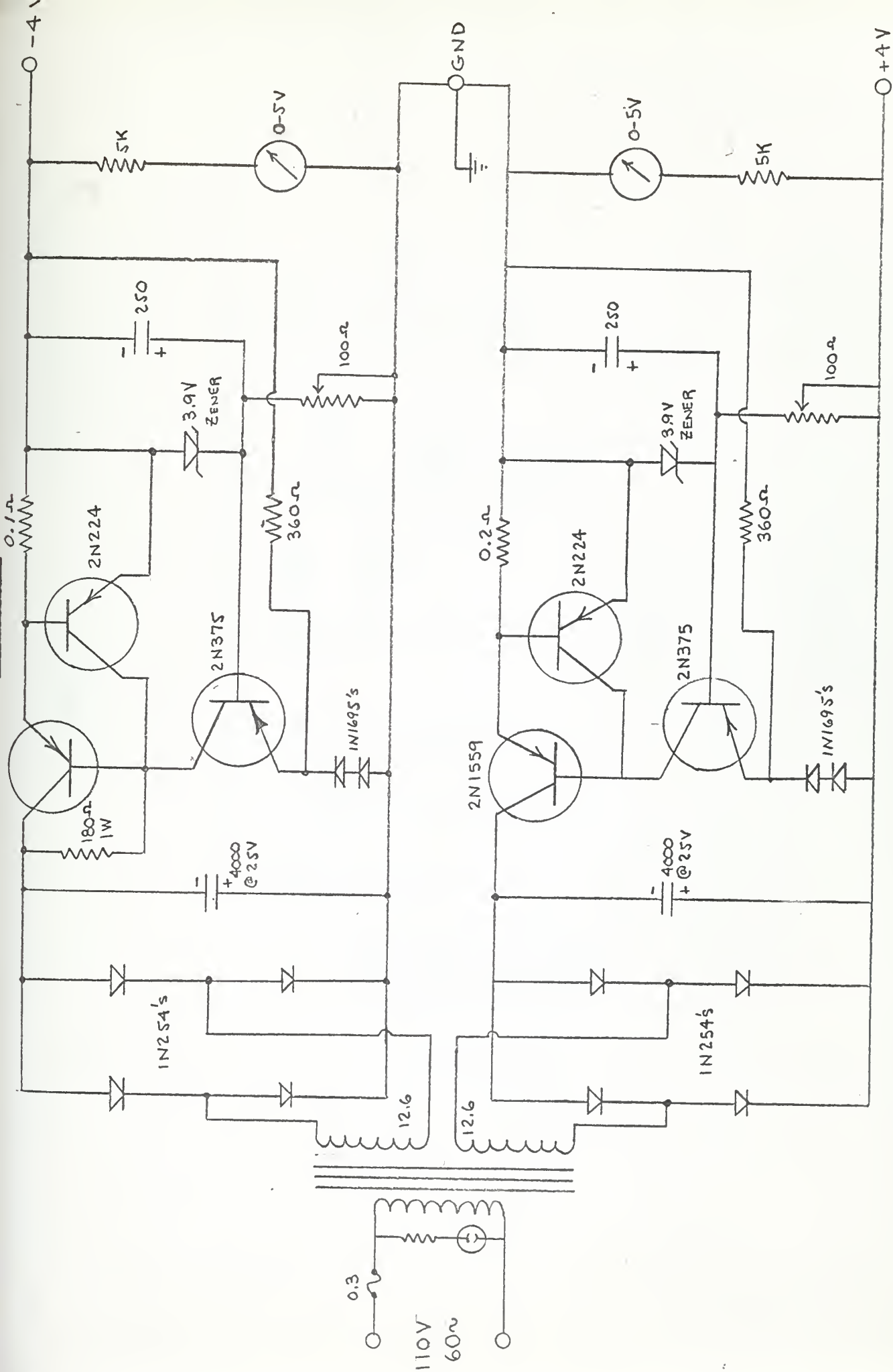

APPENDIX IV

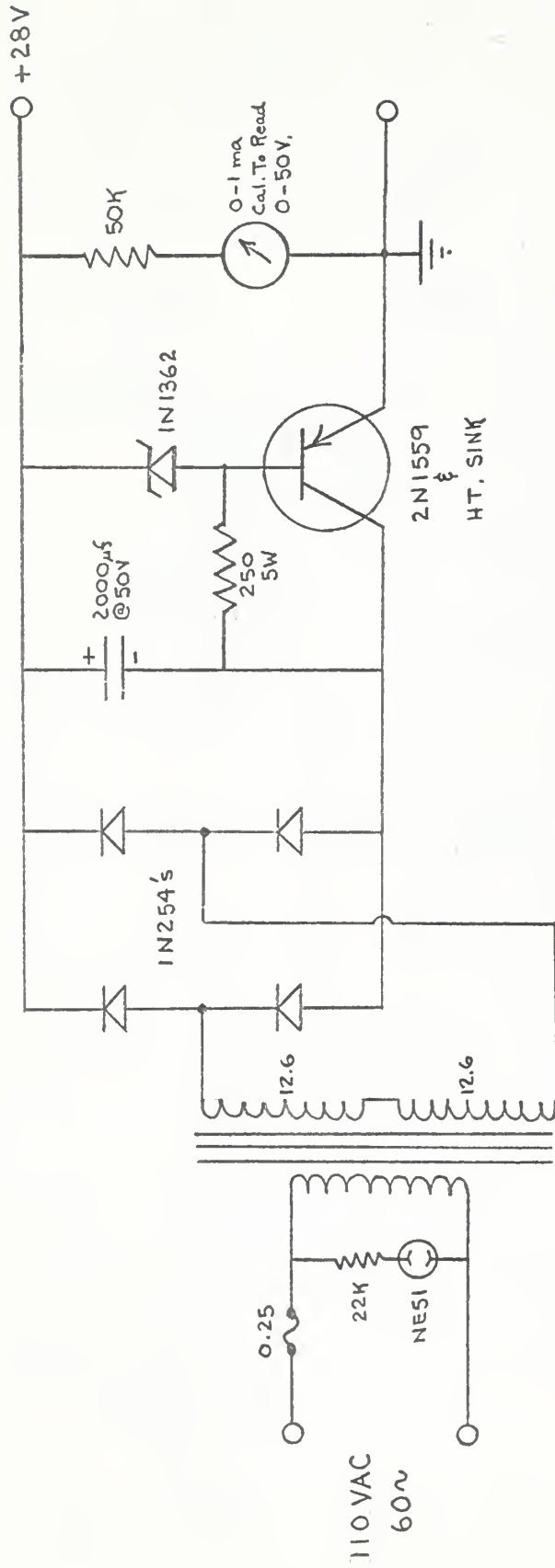

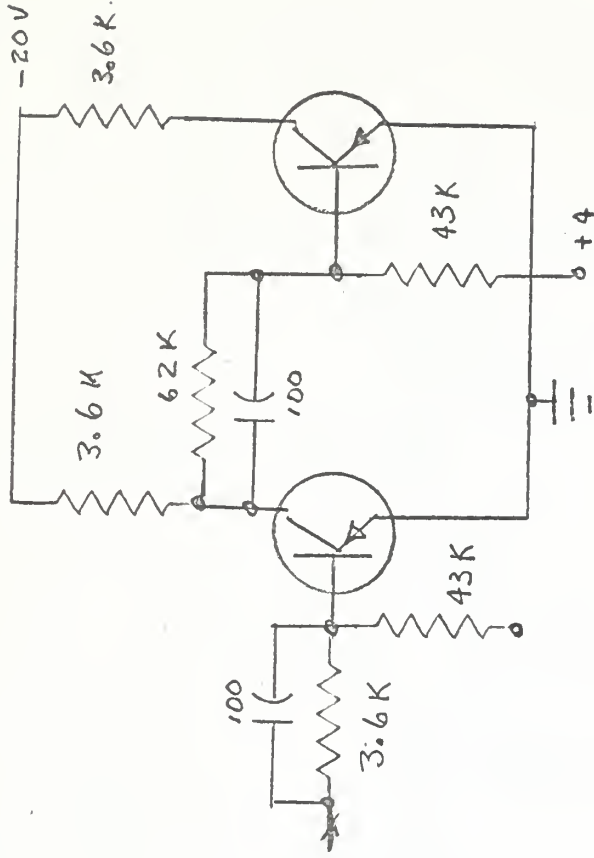
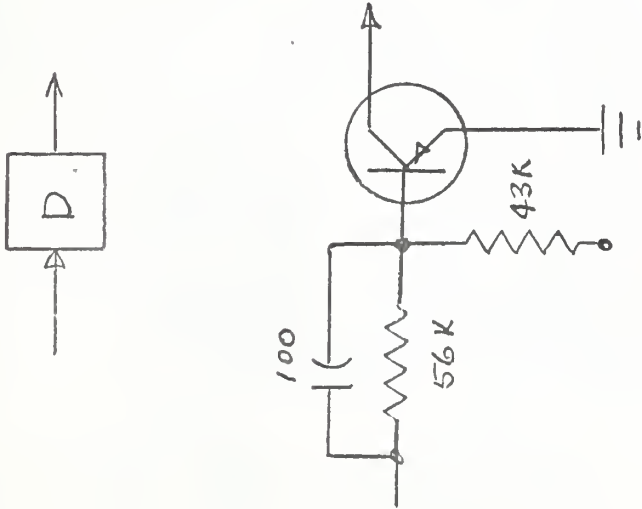

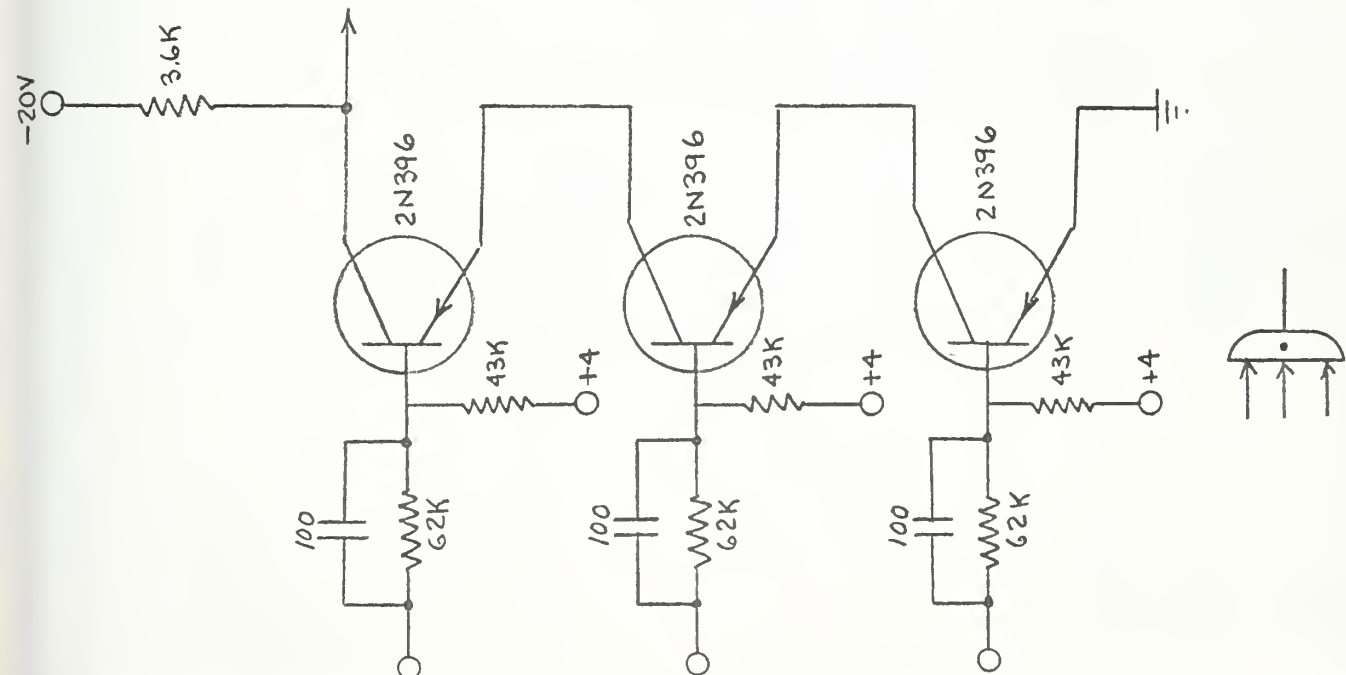
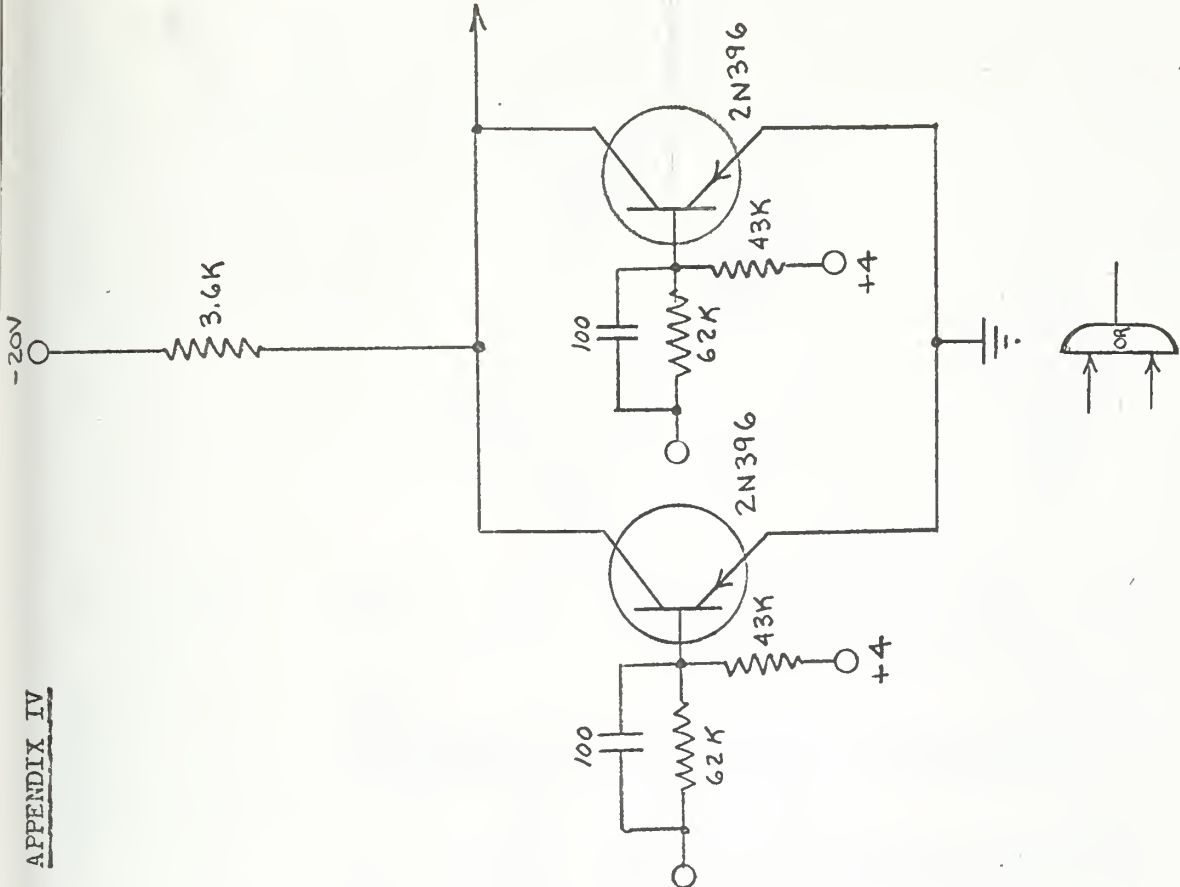

APPENDIX IV

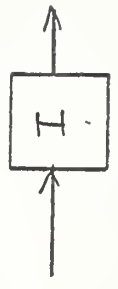
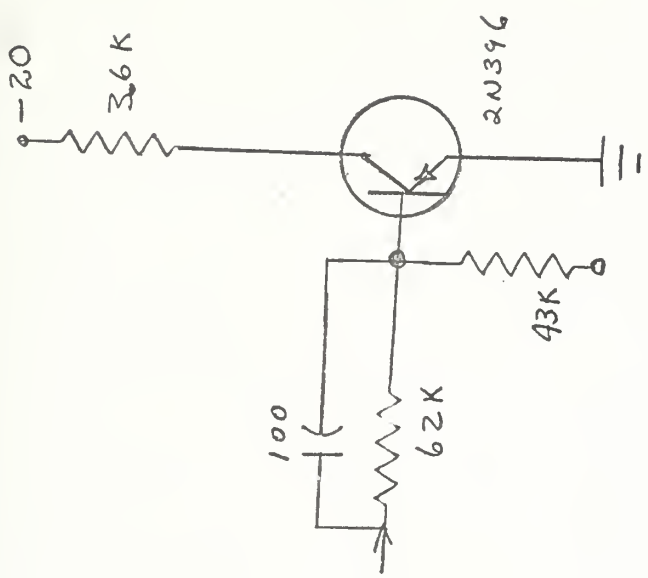
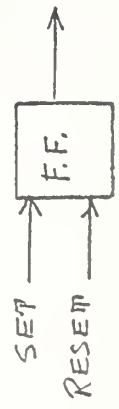
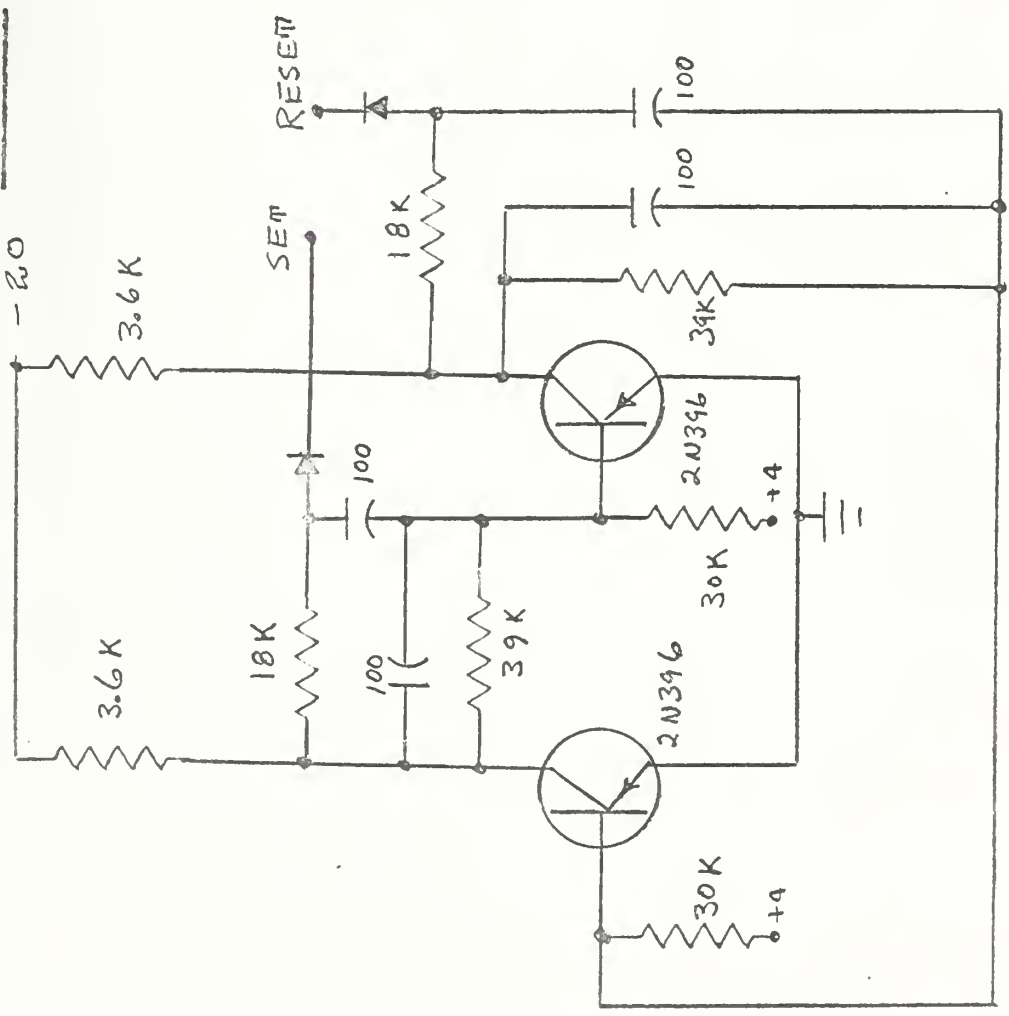

thesA4855

Proton magnetometer coherence.



3 2768 001 91509 3

DUDLEY KNOX LIBRARY