

NPS ARCHIVE
1962
BOTSHON, M.

COMPUTER TECHNIQUES FOR SYNTHESIS OF
CIRCUITS WITH WIDE TOLERANCE COMPONENTS

MORTON BOTSHON
and
ROBERT G. SIEVERT

COMPUTER TECHNIQUES FOR SYNTHESIS OF CIRCUITS WITH
WIDE TOLERANCE COMPONENTS

* * * * *

Morton Botshon
and
Robert G. Sievert

COMPUTER TECHNIQUES FOR SYNTHESIS OF CIRCUITS WITH
WIDE TOLERANCE COMPONENTS

by

Morton Botshon

//
Lieutenant, United States Navy

and

Robert G. Sievert

Lieutenant, United States Navy

Submitted in partial fulfillment of
the requirements for the degree of

MASTER OF SCIENCE
IN
ELECTRICAL ENGINEERING

United States Naval Postgraduate School
Monterey, California

1 9 6 2

COMPUTER TECHNIQUES FOR SYNTHESIS OF CIRCUITS WITH
WIDE TOLERANCE COMPONENTS

by

Morton Botshon

and

Robert G. Sievert

This work is accepted as fulfilling the
thesis requirements for the degree of

MASTER OF SCIENCE

IN

ELECTRICAL ENGINEERING

from the

United States Naval Postgraduate School

ABSTRACT

This investigation is a study of the problem faced by a circuit designer who in the analysis and synthesis of his circuit must use parameters which vary over wide ranges.

A technique utilizing a digital computer resulting in design curves is developed. A second technique is demonstrated where the same design curves are obtained by another method employing an analogue computer.

Both techniques are applied to a neon photoconductor circuit and design curves are obtained with each method.

The writers wish to express their appreciation for the assistance and encouragement given them by Professor W. Conley Smith of the U. S. Naval Postgraduate School.

TABLE OF CONTENTS

Section	Title	Page
1.	Introduction	1
2.	Description of Digital Computer Design Technique	3
3.	Description of Neon-photoconductor Circuit	10
4.	Preliminary Circuit Analysis	22
5.	Digital Computer Program Technique	28
6.	Interpretation of Digital Computer Data	42
7.	Description of Electronic Analogue Computer Technique	54
8.	Conclusions	66
9.	Bibliography	71

LIST OF ILLUSTRATIONS

Figure		Page
1.	Basic Neon-photoconductor Circuit	10
2.	Compensated Neon-photoconductor Circuit	11
3.	Photoconductor Resistance Versus Temperature Curves	13
4.	Photoconductor Resistance Versus Neon Current Curves	15
5.	Photoconductor Resistance Variation Table	16
6.	Comparison of Experimental and Approximate Mathematical Curves of Photoconductor Resistance Versus Neon Current	18
7.	Compensated Neon-photoconductor Circuit	22
8.	Basic Program Flow Chart	30
9.	Basic FORTRAN Listing "Program Basic"	33
10.	Sample Digital Computer Printout for Basic Program	34
11.	Compensation FORTRAN Listing "Program Compa"	35
12.	Main Program Flow Chart	37
13.	Hyperbolic Approximation FORTRAN Listing "Program Neon"	38
14.	Second Order Approximation FORTRAN Listing "Program Light"	39
15.	Sample Digital Computer Printout for Main Programs	40
16.	Sample Digital Computer Printout for Programs Basic and Compa	44
17.	Design Curve for Hyperbolic Approximation - Compensated Curve	45
18.	Design Curve for Hyperbolic Approximation - Uncompensated Curve	46
19.	Basic Neon-photoconductor Circuit	43
20.	Final Design Curve for Hyperbolic Approximation - Digital Computer	49
21.	Comparison of Resultant Hyperbolic Area Plot with and without Delta	51
22.	Schematic diagram of Analogue Computer Circuit	56

23.	Table of Variable Parameters with Associated Potentiometers.	57
24.	Analogue Computer Output Curve, $Z = .4$	59
25.	Analogue Computer Output Curve, $Z = 1.0$	60
26.	Analogue Computer Output Curve, $Z = 1.7$	61
27.	Analogue Computer Output Curve, $Z = 2.5$	62
28.	Final Design Curve from Analogue Computer Solution	63
29.	Comparison of Final Design Areas from Hyperbolic, Second Order and Analogue Computer Solutions.	65

LIST OF SYMBOLS

I1	total series current in amperes
I2	neon tube branch current in amperes
I3	shunt branch current in amperes
V	maintaining voltage of neon tube in volts
R1	series branch resistance in ohms
R2	shunt branch resistance in ohms
Rp 1	series branch photoconductor resistance in ohms
Rp 2	shunt branch photoconductor resistance in ohms
Z	photoconductor resistance magnitude multiplying factor
T	temperature in degrees Centigrade

1. Introduction.

System reliability is the keynote in this dynamic age of mechanization where unfailing performance is expected and required. However, component parts in a systems configuration are often subject to manufacturing tolerances which may vary radically from the norm, yet a systems designer has to deal with these varying components and produce a dependable system. Dependability can be measured as a statistical quantity or as an absolute requirement. The latter definition of dependability will be used in this paper as a yardstick in measuring the success of a particular design. The problem to be undertaken in this thesis is the synthesis of a reliable system consisting of widely varying components. Reliability as used here is dependent on the components themselves not failing.

Circuit synthesis is generally interpreted as the formulation of signal flow charts and the determination of component values for the realization of a given transfer or immittance function. This paper will be concerned with only the latter part of this definition.

The specific system to be investigated and designed consists of a neon photoconductor logic circuit which is a basic building block for other logic circuitry. Justification of the important requirement of reliability in this circuit is indicated by its use as a basic element in the foundation of an entire system. Analysis and synthesis of the circuit will be restricted to a steady state investigation.

Using the specific neon photoconductor logic circuit as an example, a general technique of circuit synthesis will be proposed in which the tools of circuit analysis and inductive reasoning are utilized for synthesizing. Analysis can exist without synthesis but the converse of this statement is not true. H. S. Scheffler and F. R. Terry in their paper entitled "Description and Comparison of Five Computer Methods of Circuit Analysis"

describe three non-statistical approaches to circuit analysis. Some of their concepts in circuit analysis are adopted and extended into the field of circuit synthesis. For example the criteria, point of failure, is a basic extreme condition applicable to a circuit problem whether the investigation be of analysis or synthesis. The particular logic circuit to be investigated will be synthesized with the aid of both a digital and an electronic analogue computer. Each computer has advantages over the other which are peculiar to the methods utilized in the solution. Successful circuit synthesis by the computers produces design curves, which when properly interpreted can be an invaluable asset to the circuit designer.

2. Description of Digital Computer Design Technique.

This section explains, in general terms, a technique useful in circuit design which uses to full advantage the high speed calculating feature of a digital computer.

In designing a circuit to meet output specifications the designer is almost invariably faced with the problem of using components in the circuit which do not have constant values, but may have values in a given range. The simplest example of this point is an ordinary fixed resistance which may have any value in a range above and below its nominal value. This variation is due to manufacturing differences. A range of variation may also be due to environmental changes during circuit operation, aging or other factors.

Circuit parameters which must be selected from within a known range of variation will be referred to as "known" parameters. Other parameters, whose value can be chosen by the designer based on his design to meet specifications are defined as "design" parameters.

The final circuit or circuits decided upon by the designer must meet the specifications for any random set of the "known" parameters - each parameter in the set picked arbitrarily from anywhere in its range of variation. The designer must choose the design parameters for his circuit so that when "acceptable" values of the design parameters are used in the circuit, the circuit performance will meet specifications for any random set of the known parameters.

In simple circuits the decision as to acceptable values of the design parameters may be easy. Consider a simple voltage source and resistance circuit. If the voltage is a known parameter with variation from 5 to 10 volts and the specification on output demands a current of from 3 to 4 amperes, then the selection of acceptable values of resistance, the design

parameter is simple.

$$R_{min} = \frac{V_{min}}{I_{max}} = \frac{5}{1.5} = 3.33$$
$$R_{max} = \frac{V_{max}}{I_{min}} = \frac{10}{3} = 3.33$$

If the design parameter, R, has any acceptable value; that is any value from 1.25 to 3.33 ohms, the circuit will meet performance specifications for any value of the known parameter, voltage, in its range of 5 to 10 volts.

The example shows the significance of the terms known and design parameters, but is much too simple to demonstrate the technique developed. In the general case, there are many known parameters, each with a range of variation. There is usually a number of output specifications to be met and the designer is at liberty to pick his design parameters in sets of acceptable values.

Stated most simply, the technique begins by first writing equations which express the output as a function of the design and known parameters. By inspecting these equations and employing boundary conditions, the designer must establish a range of investigation for each of the design parameters. This range is similar to the range of variation of the known parameters, but differs in that it may be made larger or smaller during the process of design based upon the designers interpretation of the initial answers.

Once a range has been established for each parameter, the equation expressing the output must be solved for each value in the range of each parameter. The values of design parameters which yield acceptable output regardless of the values of the known parameters used are recorded and

plotted as acceptable combinations of the design parameters. A circuit built with an acceptable combination of these design parameters will provide output which meets specifications no matter what values of known parameters are used.

Since it is impossible to solve the circuit equation for every value of every design parameter and every known parameter, the ranges of these parameters must be divided into increments and the equation solved for each increment of each parameter. The selection of these increments introduces some error. As in other approximation procedures, smaller increments introduce less error. However, smaller increments lead to more combinations to investigate and thus many more calculations. If A_n is the number of increments of the n th parameter to be investigated, the total number of answers to be computed and tested is

$$(A_1)(A_2)(A_3) \dots (A_n)$$

It is seen that any reasonably complicated design problem with a practical number of increments quickly leads to an extremely large number of calculations. This problem suggests use of a digital computer with its rapid calculating ability as an invaluable tool.

In some cases it may not be necessary to investigate all increments of a known parameter. This exception was demonstrated in the trivial example stated above although not specifically pointed out. The range of acceptable resistance was determined by investigating only the maximum and minimum values of the known parameter, voltage. Because of the simple nature of the circuit it is obvious that a value of the design parameter which is acceptable at both the maximum and minimum values of the known parameter will be acceptable for any value between and only the end points need be used. The characteristic of the parameter voltage which makes this true is that the partial derivative $\frac{\partial I}{\partial V}$ is always of the same sign.

In general then, if the partial derivative of the output taken with respect to a known parameter is always of the same sign, for all values of all the other known and design parameters, only the maximum and minimum values of that known parameter need be investigated, since if the design parameters are selected to be acceptable with both these points, they will be acceptable for any value of this parameter in its range.

Since parameters of this sort mean a great reduction in the number of calculations, the equations for output should be partially differentiated with respect to each known parameter in turn to determine if derivatives of constant sign exist. The partial derivative must be of the same sign for all values of the other known parameters. This may sometimes be shown by manipulation of the derivative expression to show it is always of one sign due to its form. In other cases a worst case technique will be sufficient to prove a constant sign of the derivative. In this procedure, if the derivative is assumed to be always positive all known parameters appearing in the expression which tend to increase the derivative are set at their minimum and all those which tend to decrease the derivative are set at their maximum. If the derivative remains positive for this worst case, it can be assumed always positive. This procedure has the weakness that it may not be evident whether a given parameter tends to increase or decrease the derivative. Also, in general, if the range of parameter variation is very large, the derivatives will not pass this worst case test and the parameter must be divided into increments for investigation.

When the ranges of all parameters have been divided into increments to be tested whether numerous increments or only one (end points type of parameter) the computer program is written. This program solves for the output using each increment of each design parameter in combination with

each increment of each known parameter. The output resulting from each set of parameters is tested and those sets which result in output which meets specifications are stored and printed.

The output of the computer can most easily be interpreted if presented in graphical form. If there is just one design parameter this is not necessary. A most useful presentation for two design parameters is a plot of one versus the other. Starting with the data for one value of a selected known parameter; for each value of one design parameter, the maximum and minimum acceptable values of the other are plotted. Connecting all such points will yield an area. The values of design parameters corresponding to any point within this area when used with the previously selected known parameter will result in a circuit which will meet design specifications.

This procedure is repeated until area plots are obtained for every increment of each of the known parameters. In each case one design parameter is plotted versus the other utilizing the same scales. If all these plots are overlaid, the area which is common to the acceptable area of all the graphs is the final design area desired. If a point in this final common area is selected and the corresponding values of design parameters are used in a circuit, the circuit will meet specifications for all known parameters.

The requirement for obtaining an area graph for each increment of each known parameter demands much tedious plotting. This is essentially the procedure; however, it is possible to write the computer program so that the data will be partially processed by the computer before printing thus eliminating some of the plotting and overlaying. This programming method is most easily described by use of a specific example and is demonstrated in a later chapter.

It is quite possible that when the acceptable area graphs for the increments of known parameters are overlayed there will be no acceptable area which is common to all the graphs. Thus there are no combinations of design parameters which will guarantee satisfactory circuits for random known parameters. This condition can occur because the specifications on the output are too strict. This may be stated another way by saying that the range of one or more of the known parameters is too large. The difficulty may be corrected by relaxing the specifications on the output or dividing one of the known parameters into two groups. If the troublesome known parameter is divided into two groups, each of which has half the range of variation of the parameter, there may then be common areas of acceptable values for these half ranges and all other known parameters. In this case then there are in effect two design areas rather than one and the divided parameter must be tested and separated into two groups before one can use this procedure to design a circuit.

If the area is large, it may be possible to tighten the output specifications to be met or to add another specification. Doing either of these will tend to reduce the size of the area. By inspecting the size of the area resulting from the initial output specifications, a decision can be made as to how the specifications can be altered. By inspecting subsequent results and making further adjustments a balance between specifications and available combinations of design parameters can be achieved.

The technique described results in an area of acceptable design values. If the designer picks a set of design values from in the final area, he is assured that the circuit will meet output specifications. The question still remains, "If all the combinations in the area meet specifications is there not one best combination or some part of the area

which yields better circuits than other parts?" The techniques described up to the point will not answer this question.

One method of determining the best part of the final common area is to select one of the preliminary area plots. This plot corresponds to one set of known parameters. Using this set of known parameters and representative values of design parameter combinations throughout the area, one calculates the value of one of the output quantities. The values calculated are plotted at the corresponding point in the area. Inspection of the plot may reveal a trend in the value of the output parameter and indicate a portion of the area where this value best approximates its optimum value. This process may be repeated with other sets of known parameters and the corresponding area until it is established that the trend holds in enough of these preliminary areas that it may be assumed to hold in the final area plot.

In summary the technique which has been described in this section results in a plot of one design parameter versus the other. An area of acceptable combinations of the two design parameters can be drawn on this plot. If a combination is selected from inside this area and a circuit constructed using this combination and any combination of the known parameters used in the circuit, the resulting circuit will meet the desired output specifications.

3. Description of Neon-photoconductor Circuit.

The circuit chosen to illustrate the technique described briefly in the preceding chapter is a neon tube - photoconductor circuit which is used as a basic building block in the design of computer logic circuits. The basic circuit is shown in figure 1.

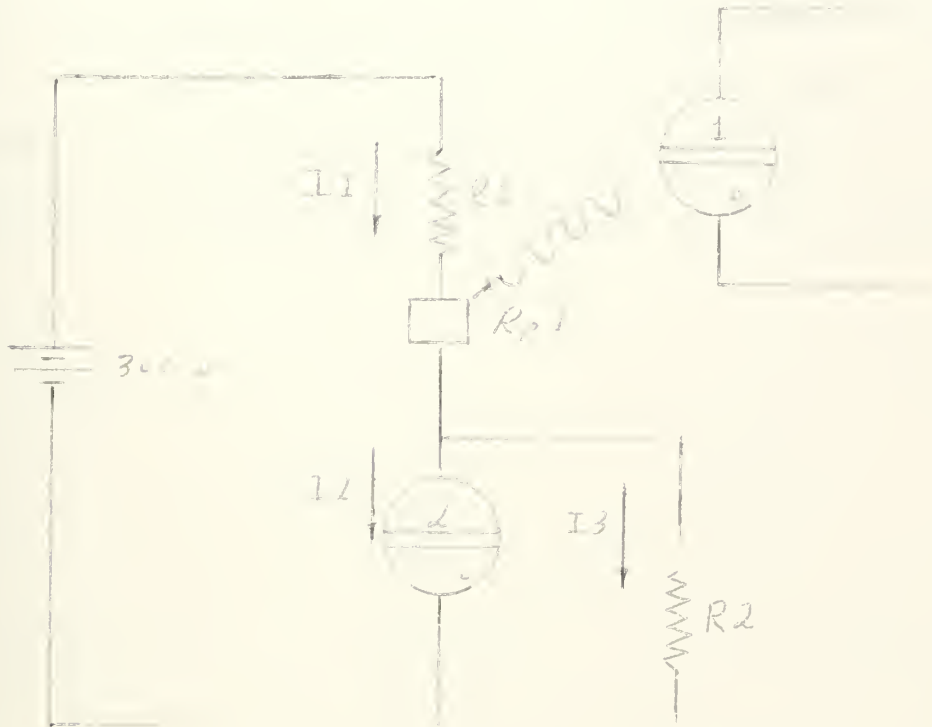

Figure 1.

The circuit consists of a neon tube, two fixed resistances, R_1 and R_2 and a photoconductor, R_{p1} , supplied from a 300 volt source.

In the circuit, the output quantity of interest is the light of neon tube two. The input is light from a similar external neon tube, called number one. With no input, there is no output; the very high dark resistance of the photoconductor which is in the mega ohm region limits current flow and keeps the voltage drop across neon number two low enough to prevent its firing. With input light from neon number one, the resistance of the photoconductor drops radically to its light resistance value of a

few kilohms and neon number two fires, producing light output.

The light output from neon number two is used as input to subsequent circuits so it is essential that it be as nearly constant as possible for stable operation. This constant current characteristic is not possible with the circuit as shown since the resistance of the photoconductor is a function of temperature. As the circuit operates, the ambient temperature rises, causing the photoconductor resistance to rise and the neon current to decrease. A proposed method of compensation intended to minimize this temperature effect is to insert a similar photoconductor in the shunt branch of the circuit as shown in figure 2.

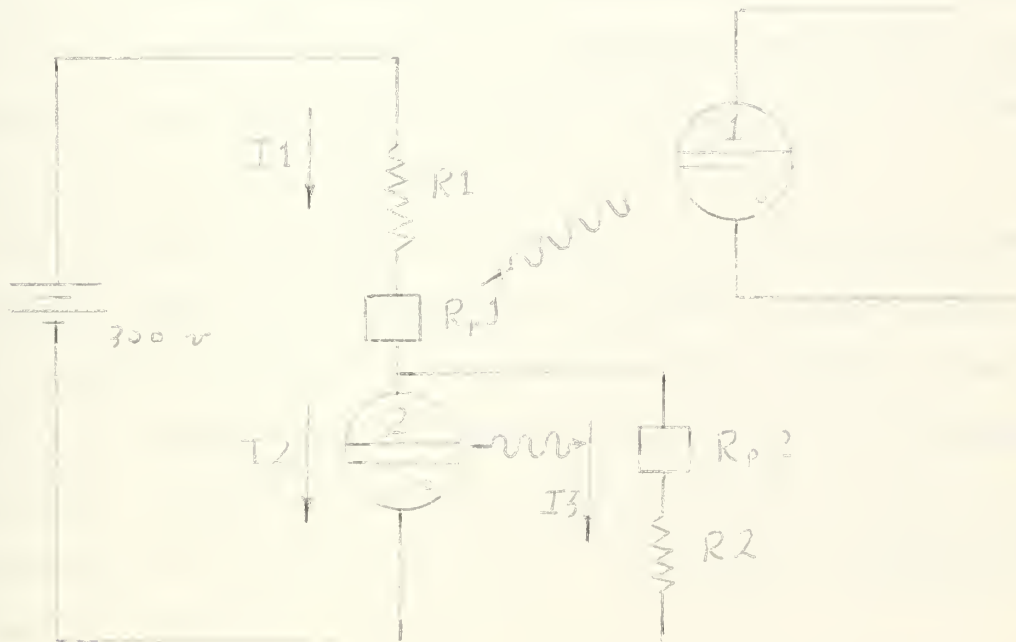

Figure 2.

In this compensated circuit the output current is more nearly constant despite temperature increase because of the feedback nature of the output light shining on photoconductor R_{p2} . Now, as the output current tends to decrease as a result of temperature variation changing the resistance of R_{p1} , the light output decreases, increasing the resistance of

R_p and shunting more of the available current through the neon tending to maintain the current constant.

The problem then is to design a circuit, using available components, which will give a nearly constant output light or current, throughout the operating temperature range of 25 to 55 degrees Centigrade. The supply voltage is assumed to be a constant 300 volts. The neon to be used is a General Electric NE2 type which has a firing voltage of 135 volts and a maintaining voltage of from 60 to 100 volts.

The characteristics of the photoconductors employed in the circuit are more complex since the value of photoconductor resistance is a function of both the ambient temperature and the incident light. The latter variation is more easily investigated if neon current rather than light is considered the determining factor. Mathematical relationships governing photoconductor resistance variation with temperature and with current have been determined from experimental data.

The temperature dependence of resistance can be obtained by considering figure 3 where \log_{10} of resistance in kilohms is plotted versus temperature in degrees Centigrade for three typical photo conductors. The curves are all for a constant incident light corresponding to two milliamperes of neon current. Since the data plots as a straight line on semi-log paper the variation is of the form $R_p = A e^{kx}$. If curve II is selected to determine the constant,

$$R_p(25^\circ) = A e^{25k} = 2.3 \times 10^3 \text{ ohms} \quad (1)$$

$$R_p(55^\circ) = A e^{55k} = 4.0 \times 10^3 \text{ ohms} \quad (2)$$

Dividing (2) by (1)

$$e^{30k} = \frac{4.0}{2.3} = 1.73$$

$$k = .0183$$

Thus

$$R_p = A e^{0.0183T}$$

PHOTOCONDUCTOR RESISTANCE
VERSUS
TEMPERATURE

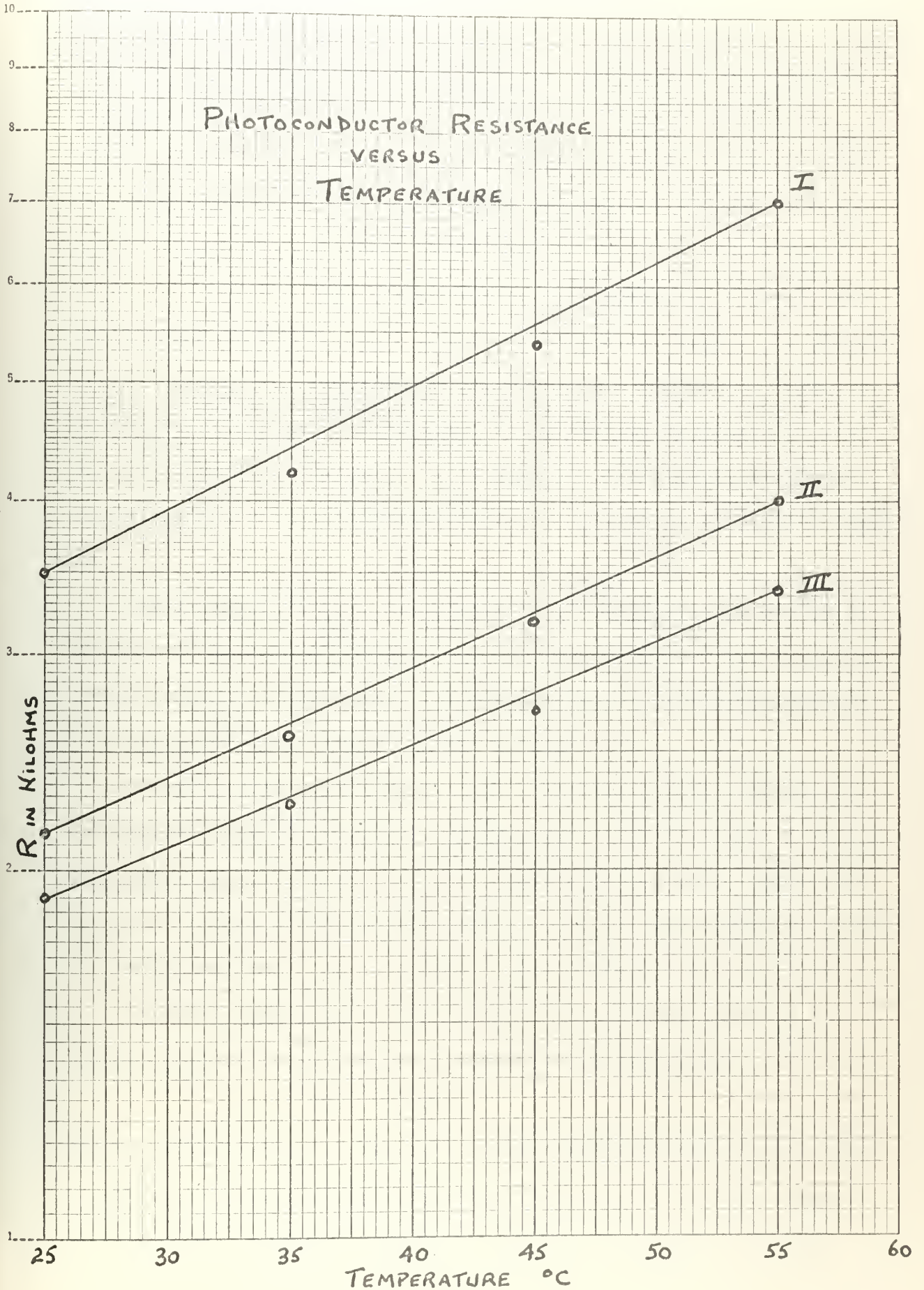

H. W. KEUFFEL & ESSER CO. MADE IN U.S.A.
1 CYCLE X 70 DIVISIONS

The coefficient A and the mathematical relationship expressing resistance variation with neon current can be obtained by considering figure 4. In this curve, photoconductor resistance in kilohms is plotted versus current in the exciting neon expressed in milliamperes; the curves are all for a constant temperature of 40° C. The three curves A, B, and C are for three representative photoconductors, A and C show the extremes of variation and curve B is considered typical. In attempting to express the photoconductor resistance as a function of light, it was noted that curves A, B and C are all of the same mathematical form and are related by a constant. This magnitude multiplying factor will be defined as Z. This relationship is best illustrated by table I, figure 5.

The current-resistance characteristic of any photoconductor can be obtained by deriving a mathematical expression which will fit one of the curves giving the proper form of variation and then multiplying the entire expression by a constant to fix its magnitude.

Curve B, selected as typical will be the one used to determine the mathematical form of variation. If this expression is assumed to have a magnitude multiplying factor of unity, reference to figure 4 shows that in order to cover the range from curve A to curve C the magnitude multiplying factor must have values of from .4, for curve A to 2.5 for curve C .

The first approximation to curve B which was investigated is a hyperbolic function where K_1 is a constant to be determined.

$$R_p = \frac{K_1}{I}$$

Since a neon current of 2 ma. will be used as the mean point about which to design, the hyperbola constant was determined to fit curve B exactly at that point. From the curve at $I = 2.0$ ma., $R_p = 4.388 \times 10^3$ ohms.

PHOTOCONDUCTOR RESISTANCE VARIATIONS

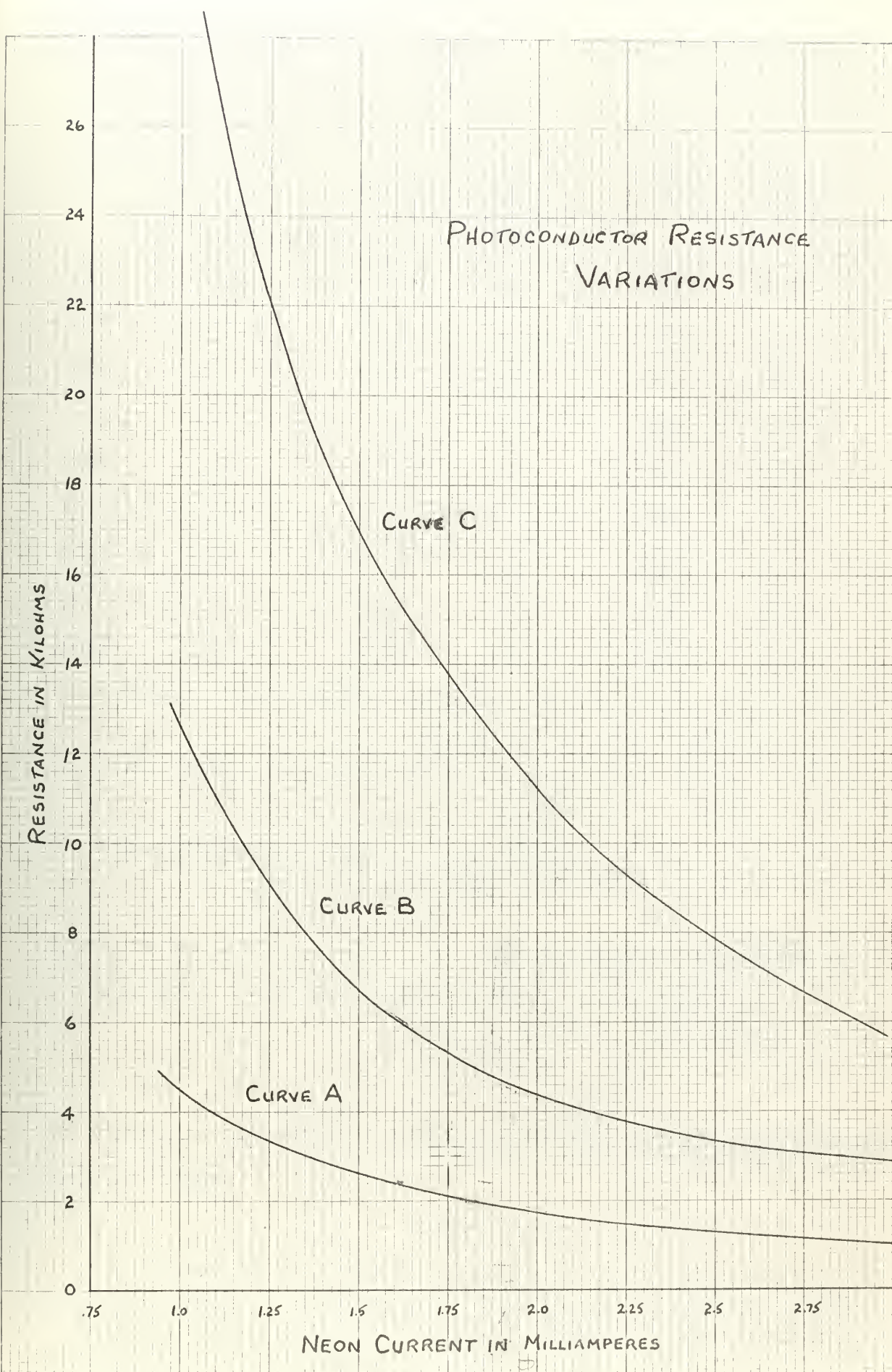

Fig. 4

Table 1

Current in ma.	R _p Curve A in Kohm	R _p Curve B in Kohm	R _p Curve C in Kohm	$\frac{R_p(A)}{R_p(B)}$	$\frac{R_p(C)}{R_p(B)}$
1.00	4.48	12.66	30.8	.354	2.43
1.25	3.38	9.07	22.0	.370	2.43
1.50	2.78	6.71	17.0	.414	2.53
1.75	2.06	5.32	13.86	.388	2.60
2.00	1.72	4.388	11.22	.394	2.54
2.25	1.46	3.79	9.28	.396	2.44
2.50	1.26	3.37	7.88	.374	2.34
2.75	1.11	3.04	6.76	.363	2.22
3.00	1.00	2.89	5.82	.346	2.02

Figure 5

$$K_1 = R_p I = (4.388 \times 10^3)(2.0 \times 10^{-3}) = 8.776$$

$$\therefore R_p = \frac{8.776}{I}$$

Incorporating the effect of temperature,

$$R_p = \frac{8.776 K_2}{I} e^{0.0183 T}$$

Since the value of $R_p = 4.388 \times 10^3$ ohms from curve B corresponds to

$I = 2\text{ma.}$ and $T = 40^\circ\text{C}$ the constant $8.776 K_2$ can be determined

$$4.388 \times 10^3 = \frac{8.776 K_2}{2 \times 10^{-3}} e^{0.0183(40)}$$

$$8.776 K_2 = 4.22$$

The hyperbolic expression with temperature effect included approximating curve B is then

$$R_p = \frac{4.22}{I} e^{0.0183 T}$$

To include the fact that the magnitude of the resistance can vary from curve A values to curve C values, the magnitude multiplying factor

Z must be included. The complete resistance expression for the photoconductor is then

$$R_p = \frac{1.72 \times 10^{-3}}{I} \quad \mu = 0.01537$$

In the circuit being analyzed, Rp1 is supplied with exciting light from an external neon, neon number 1, which is assumed to provide a constant light intensity corresponding to a neon current of 2 ma. Therefore:

$$R_{p1} = \frac{1.72 \times 10^{-3}}{2 \times 10^{-3}} = 0.86 \times 10^{-3} \Omega$$

$$R_{p1} = 2.11 \times 10^{-3} \Omega \quad \mu = 0.01537$$

The compensating photoconductor Rp2 is excited by light fed back from the output neon, neon number 2. This light corresponds to the output current I₂. Therefore:

$$R_{p2} = \frac{4.22 \times 10^{-3}}{I_2} \quad \mu = 0.01537$$

The plot of the hyperbolic approximation to curve B shown in Figure 6 indicates that the hyperbolic curve fits experimental data exactly only at I = 2.0 ma. Since circuit performance with currents from 1.5 ma. to 2.5 ma. is of interest, the use of the hyperbolic approximation introduces some error especially at the lowest value of 1.5 ma. where the error is 12.8%.

The expression for photoconductor resistance is used in subsequent calculations and the simplicity of the hyperbolic expression is an advantage when used in more complex expressions. However, a more accurate curve fit over the entire 1.5 to 2.5 ma. current range was desired.

The second approximation to curve B which was investigated was derived by assuming the curve to be of the form:

$$AR_p I + BI + CR_p + D = 0$$

where A, B, C, and D are constants to be determined. Appendix I shows the

PHOTOCONDUCTOR RESISTANCE VERSUS
NEON CURRENT

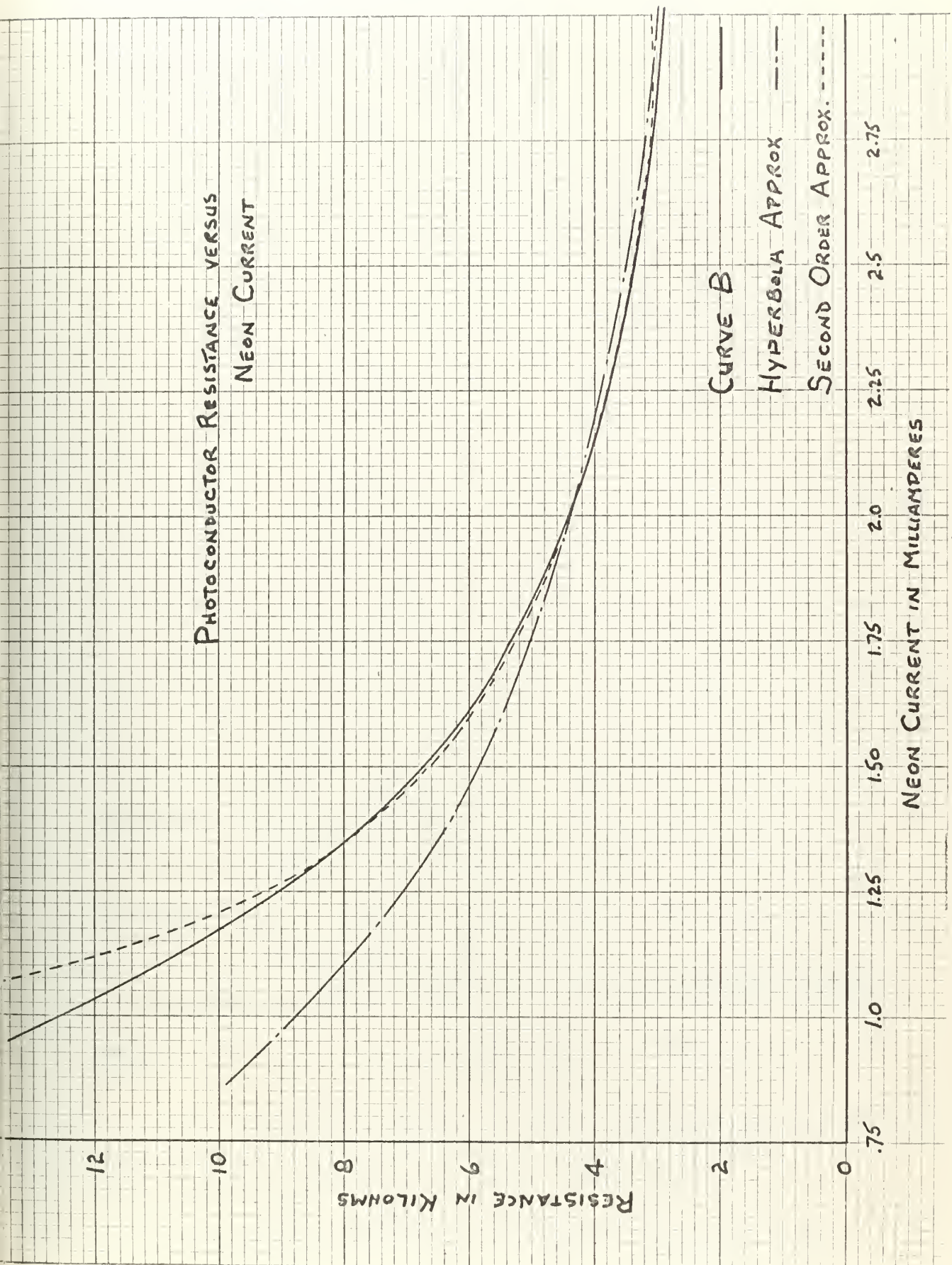

CURVE B

HYPERBOLA APPROX

SECOND ORDER APPROX.

calculations leading to the final form

from which

$$R_p = \frac{20 \times 10^3 I + 575}{192810 I - 10^6}$$

Including the effect of temperature as in the hyperbolic approximation:

$$R_p = 482 \left(\frac{10^6 - 10^5 T}{10^6 - 10^5 T + 10^5} \right) \times 10^3$$

In the circuit being analyzed, R1 is supplied by light from neon one which has a constant current of 2.0 ma. therefore:

$$R_{p1} = 482 \left[\frac{(10^6 - 10^5 (20)) + 10^5}{10^6 - 10^5 (20) + 10^5} \right] \times 10^3$$

R_{p1} is called the resistance

resistance have such large ranges of variation, an output current of from 1.5 to 2.5 ma. will meet specifications. R1 and R2 must be chosen such that this specification is met with any neon tube and any photoconductor having characteristics within the ranges discussed above. The only assumption being that both photoconductors have the same value of magnitude multiplying factor, Z. A further specification is that for any finished circuit which will have one value of neon voltage, V, and one value of Z, the variation in current due to temperature change from 25°C to 55°C shall not be greater than .15 ma. The effect of imposing stronger restrictions on the output will be investigated and the results compared.

The upper limit on the values of R1 to be investigated can be established by setting the current I1 = 1.5 and the voltage V = 60, then

$$R1_{max} = \frac{2.5 \times 10^{-3} \times 60}{1.5 \times 10^{-3}} = 100 \times 10^3$$

R1_{min} cannot be as conveniently set since its value depends upon the value of R2 which has not yet been determined. A rough initial estimate can be obtained by assuming no current flow through the shunt branch and ignoring the contribution of Rpl in comparison with R1 then

$$R1_{min} = \frac{3.0 \times 10^{-3}}{2.5 \times 10^{-3}} = 1.2 \times 10^3$$

In view of the approximations made here, a more pessimistic value of 20 kilohms should probably be chosen. Experience has shown that a range of from 40×10^3 to 130×10^3 ohms for R1 will adequately cover the possible values of R1 to have the circuit meet output specifications.

The maximum value of R2 is indeterminate since the effect of increasing R2 is to shunt more current through the neon tube. It can be seen that if I1 is 2.5 ma. or less, R2 can be increased without bound and the current I2 will never exceed the output specification. The minimum value of R2 is also indeterminate. In the uncompensated circuit a minimum value of R2 can

be determined because a lower limit exists below which the neon voltage will not be above the 135 volts necessary for firing. In the compensated circuit however, due to the very high dark resistance of the compensation photoconductor, the neon will fire for any value of R2. The magnitude of $R1_{\min}$ was selected as an initial lower limit for R2 also. An initial upper limit of 700 K ohms was selected. Subsequent experience showed that a range of R2 from 40×10^3 to 530×10^3 ohms was sufficient to yield the desired design curves.

4. Preliminary Circuit Analysis.

This section deals with the application of the design technique developed in Section 2 to the neon-photoconductor circuit which has been previously described.

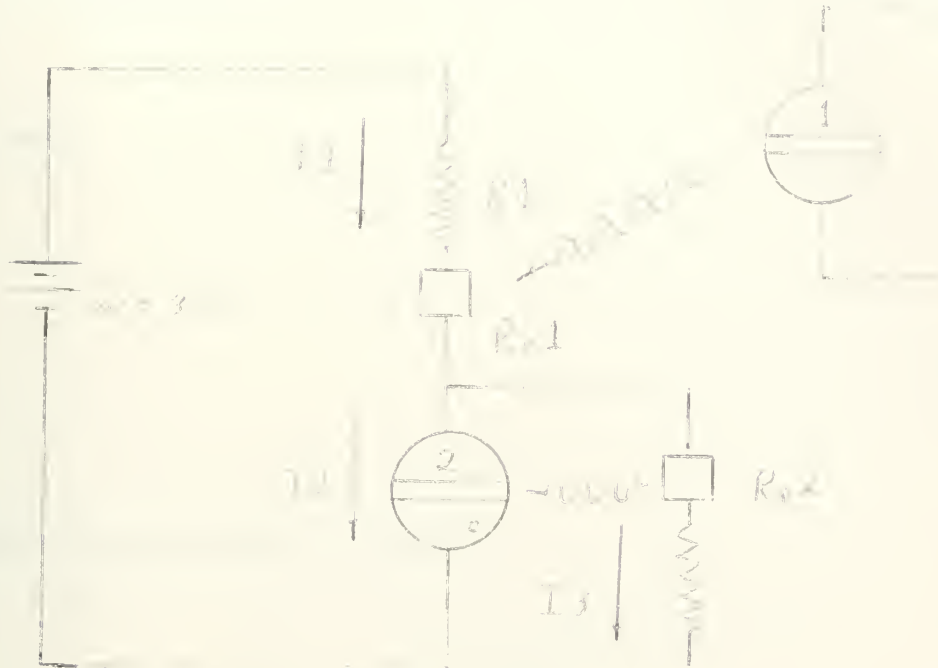

Figure 7.

The output quantity of interest is the light from neon number 2. As previously noted, the output is more easily expressed as the current through the neon, an equally good measure of performance. The technique first requires an equation expressing the output as a function of the other parameters.

$$I_1 = \frac{V_{cc} - V}{R_1 + R_{p1}}$$

$$I_2 = \frac{V}{R_2 + R_{p2}}$$

$$I_3 = \frac{V_{cc} - V}{R_3 + R_{p3}}$$

If the hyperbolic approximation is used for photoconductor resistance,

$$I_2 = \frac{V - V_0}{R_1 + 2.11 \times 10^2 \times 2 \times 10^{-5} e^{-0.015 I_2}} = \frac{V - V_0}{R_2 + 4.22 \times 10^2 \times 2 \times 10^{-5} e^{-0.015 I_2}}$$

This equation can be easily manipulated into the form of a quadratic

$$A I_2^2 + B I_2 + C = 0$$

where

$$A = (R_1 R_2 + 2.11 \times 10^2 \times 2 \times 10^{-5} \times 0.015 I_2) \times 10^3$$

$$B = \left[2.11 \times 10^2 \times 2 \times 10^{-5} \times 0.015 \left(V + \frac{V R_1}{R_2} + 1.22 \times 10^2 \times 2 \times 10^{-5} \times 0.015 I_2 \right) + V R_2 + R_2 (V - V_0) \right] \times 10^3$$

$$C = -4.22 \times 10^2 \times 2 \times 10^{-5} \times 0.015 I_2 (V - V_0)$$

Then by the quadratic equation:

$$I_2 = \frac{-B \pm \sqrt{B^2 - 4AC}}{2A}$$

Inspection of the coefficients A, B, and C shows that since A is always positive and C is always negative (the maximum value of V is 100) the quantity resulting from evaluating the radical will be greater than B. Since current I₂ cannot physically be in the direction opposite to that assumed, a negative answer for I₂ has no significance and the equation to be solved with the computer is

$$I_2 = \frac{-B + \sqrt{B^2 - 4AC}}{2A}$$

If the second order approximation for photoconductor resistance is used:

$$I_2 = \frac{V - V_0}{R_1 + 2.11 \times 10^2 \times 2 \times 10^{-5} e^{-0.015 I_2}} = \frac{V - V_0}{R_2 + 4.22 \times 10^2 \times 2 \times 10^{-5} e^{-0.015 I_2} \left(\frac{1.1 \times 10^2 I_2 + 3.4}{1.42 \times 10^3 I_2 - 1} \right)}$$

This equation can also be manipulated into the quadratic form:

$$A I^2 + B I + C = 0$$

where the coefficients are somewhat more complex,

$$A = \left\{ 2.11 \times 10^{-2} Z e^{-0.015 T} \left[1.42 R_2 + 2.11 \times 10^{-2} Z e^{-0.015 T} + 2.11 R_1 \right] + 1.42 \times 10^{-2} R_1 Z \right\} / 10^4$$

$$B = \left\{ 2.11 \times 10^{-2} Z e^{-0.015 T} \left[\frac{R_1}{10} + 2.11 \times 10^{-2} Z e^{-0.015 T} + 1.42 (300 - V) \right] - R_1 R_2 + 2.11 \times 10^{-2} Z e^{-0.015 T} \left[1.42 \times 10^{-2} V - R_2 \right] + 1.42 \times 10^{-2} \left[V R_1 - 300 R_2 + V R_2 \right] \right\} / 10^4$$

$$C = Z e^{-0.015 T} \left[2.11 \times 10^{-2} (V - 300) - 2.11 \times 10^{-2} V \right] + (300 - V) R_1 - V R_1$$

The same quadratic formula must then be solved:

$$I = \frac{-B \pm \sqrt{B^2 - 4AC}}{2A}$$

In order to determine whether any of the known parameters fall into the category where only the maximum and minimum values need to be investigated, partial derivatives of I2 with respect to V, Z, and T must be taken and checked to see if they are of constant sign.

$$A I^2 + B I + C = 0$$

For the hyperbolic case:

$$A \left(2I \frac{\partial I}{\partial T} \right) + I^2 \frac{\partial A}{\partial T} + B \frac{\partial I}{\partial T} + \frac{\partial B}{\partial T} I + \frac{\partial C}{\partial T} = 0$$

$$\frac{\partial I}{\partial T} = \frac{-I^2 \frac{\partial A}{\partial T} - I \frac{\partial B}{\partial T} - \frac{\partial C}{\partial T}}{2AI + B}$$

$$\frac{\partial A}{\partial T} = 2.11 Z R_2 (0.21837) e^{-0.015 T} / 10^4$$

$$\frac{\partial B}{\partial T} = -0.336 Z e^{-0.015 T} \left(V + \frac{3R_1}{10} + 2.44 Z e^{-0.015 T} \right)$$

$$\frac{\partial C}{\partial T} = -0.22 (300 - V) Z e^{-0.015 T} (V - 300)$$

the worst case values of all the parameters will occur simultaneously. However, since a positive slope was calculated, the pessimistic alternative must be chosen and the temperature must be investigated in increments. A similar worst case analysis on $\frac{\partial I_2}{\partial x}$ leads to the same conclusion.

The variation of I_2 with V will be investigated next.

$$A I_2^2 + B I_2 + C = 0$$

$$2A I_2 \frac{\partial I_2}{\partial V} + I_2^2 \frac{\partial A}{\partial V} + B \frac{\partial I_2}{\partial V} + I_2 \frac{\partial B}{\partial V} + \frac{\partial C}{\partial V} = 0$$

$$\frac{\partial A}{\partial V} = 0$$

$$\frac{\partial B}{\partial V} = 2.11 \times 10^{-4} \times e^{-0.0153T} + R_1 + R_2$$

$$\frac{\partial C}{\partial V} = 4.22 \times 10^{-4} \times e^{-0.0153T}$$

$$\frac{\partial I_2}{\partial V} = \frac{-I_2 \frac{\partial B}{\partial V} - \frac{\partial C}{\partial V}}{2A I_2 + B}$$

Since $\frac{\partial B}{\partial V}$ and $\frac{\partial C}{\partial V}$ are always greater than zero $\frac{\partial I_2}{\partial V}$ will be negative as long as

$$2A I_2 + B > 0$$

Since

$$I_2 = \frac{-B + \sqrt{B^2 - 4AC}}{2A}$$

$$2A \left(\frac{-B + \sqrt{B^2 - 4AC}}{2A} \right) + B > 0$$

$$\sqrt{B^2 - 4AC} > 0$$

Since $A \neq 0$ and $B \neq 0$ this last inequality holds and thus the initial assumption of a negative $\frac{\partial V}{\partial T}$ is true. Since $\frac{\partial V}{\partial Z}$ is always negative, only the maximum and minimum values of V are investigated.

When a similar analysis of these partial derivatives is made using the more accurate second order approximation, it is found that $\frac{\partial V}{\partial T}$, $\frac{\partial V}{\partial Z}$ and $\frac{\partial V}{\partial R_1}$ all have possible changes in sign and therefore when this approximation is used all three parameters must be investigated using increments. This condition is then one disadvantage to using the second order approximation.

When it has been determined that a parameter must be investigated using increments, the magnitude of the increments must be chosen. As pointed out in Section 2, the number of increments selected is a compromise between accuracy and keeping the number of calculations reasonable. The initial choice of increments was as follows:

$T = 25, 35, 45, 55,$

$Z = .4, .9, 1.4, 1.9, 2.5,$

$V = 60, 100,$ for hyperbolic approximation,

$V = 60, 70, 80, 90, 100,$ for second order approximation,

$R_1 =$ in 10 kilohm increments,

$R_2 =$ in 20 kilohm increments.

Plots made using these increments showed that parts of the range of R_1 caused the value of R_2 to increase rapidly with possible inaccuracy in the plot. The reason for this rapid increase is explained in Section 6. To eliminate this possible inaccuracy the increments of R_1 were altered so that in the questionable region the increments were taken much smaller (2 Kilohm increments).

The problem has at this point been reduced to the solution of a quadratic equation with coefficients made up of the five parameters R_1 , R_2 , T , Z and V . The equation is to be solved for all combinations of each of the increments of the five parameters.

5. Digital Computer Program Technique

The solution of a quadratic equation whose coefficients are functions of five variables and where the number of solutions is the product of the parameter increments is ideally suited to a digital computer. A parameter increment is defined as the number of values that a variable will be assigned spanning its entire range of variation. The number of combinations of parameters to be examined in this case will be denoted by N where:

$$N = (21)_{21} \times (34)_{22} \times (5) \times (6) \times (4) = 71,400$$

Programming of a digital computer in machine language requires an elaborate and complex sequence of instructions to specify every step of an operation. With the advent of the FORTRAN processor in late 1956, the intricacies of programming were no longer a stumbling block. Although the FORTRAN system was developed by J. W. Backus at IBM, it has found universal acceptance for all types of digital computers. The FORTRAN processor has made it possible for scientists and engineers to apply the language of ordinary mathematics to their individual problems.

Quoting from a paper prepared by Backus and his associates, "The purpose of FORTRAN was to reduce by a large factor the task of preparing scientific problems for IBM's next large computer, the 704. If it were possible for the 704 to code problems for itself and produce as good programs as human coders (but without the errors), it was clear that large benefits could be achieved. For it was known that about 2/3 of the cost of solving most scientific and engineering problems on large computers was that of problem preparation. Furthermore, more than 90 per cent of the elapsed time for a problem was usually devoted to planning, writing and debugging the program. In many cases the development of a general plan for solving a problem was a small job in comparison to the task of

devising and coding machine procedures to carry out the plan. The goal of the FORTRAN project was to enable the programmer to specify a numerical procedure using a concise language like that of mathematics and obtain automatically from this specification an efficient 704 program to carry out the procedure. It was expected that such a system would reduce the coding and debugging task to less than one-fifth of the job it had been."

FORTTRAN (derived from formula translation) is a language that greatly resembles the language of ordinary mathematics. Symbols such as, **, *, /, +, -, in FORTRAN are digested as exponentiation, multiplication, division, addition, and subtraction. Mathematical operations such as square roots, logarithms, trigonometric and hyperbolic functions are available in the computers library of routines and used merely by referencing the appropriate operation by abbreviated name.

The Control Data Corporation 1604 digital computer was married to the FORTRAN processor in late 1961. The results of the merger produced a high speed computer that could be commanded with relative ease. Successful results with FORTRAN programming can best be achieved by following these basic rules in the order shown.

1. Block diagram - (flow chart)
2. Mathematical and logical operations to be performed
3. Transformation to FORTRAN language.

An example of a basic flow chart for the solution of the quadratic equation using the hyperbola approximation is illustrated in figure 8. The idea behind this program is to see the effect on the neon current as the temperature changes for any one set of known and design parameters.

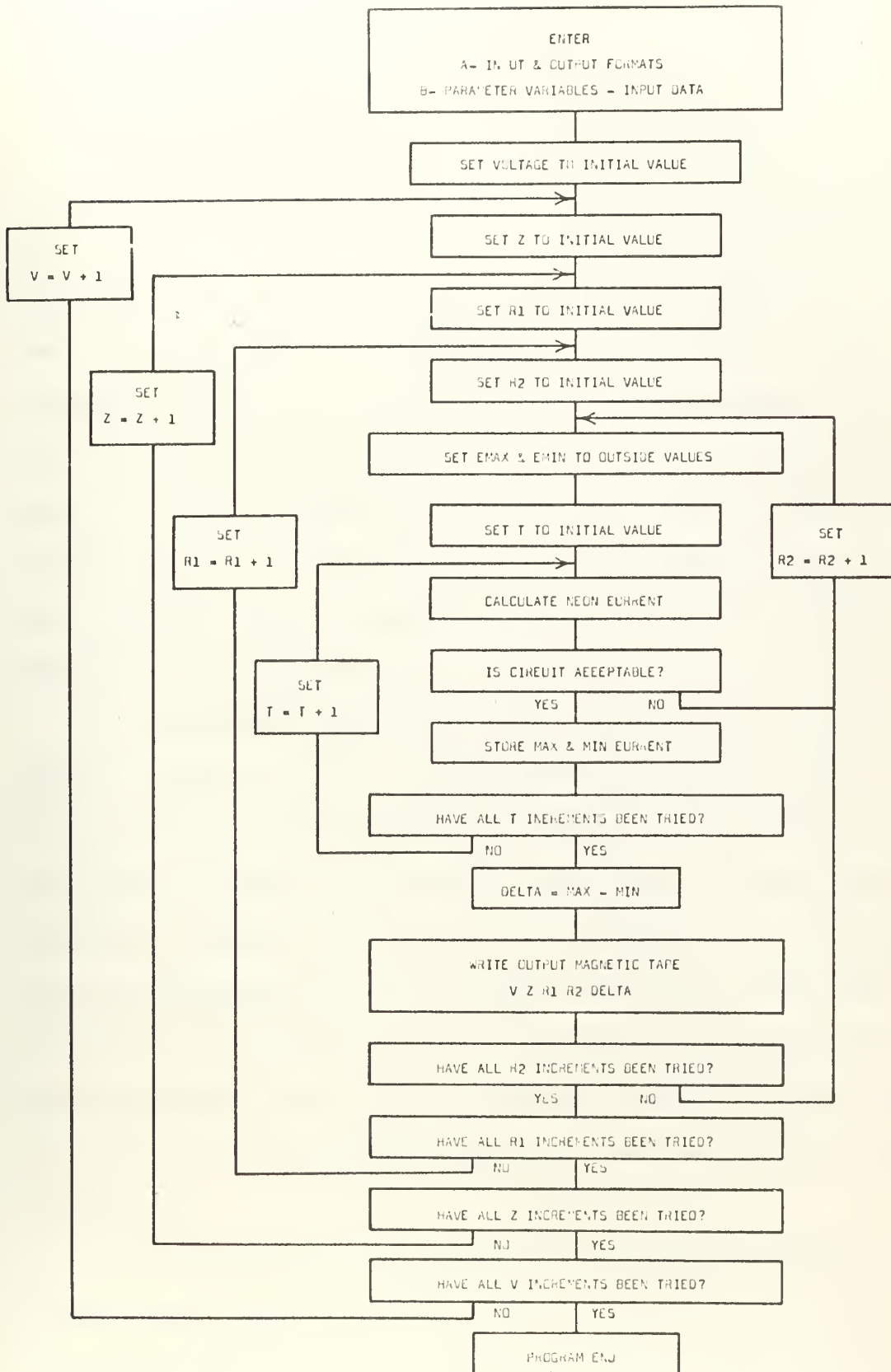

Fig. 8

The flow chart indicates the sequence of operations to be performed with alternate paths dependent on logical tests. Each block in the flow chart may represent a few calculations or logical interrogations. Essentially the flow chart in figure 8 systematically takes every possible combination of circuit parameters and tests the output current to see if it meets specifications. If a failure occurs the design parameter is altered and the calculations and logical tests are started over again. When the entire range of temperature variation has been investigated and yielded an acceptable circuit, the design and known parameter set which was responsible for the acceptable circuit for the entire temperature variation is recorded on magnetic tape. In addition to the parameter set the variation in neon current is also placed on the magnetic tape. This process continues with a new parameter combination until all parameter combinations have been investigated.

The mathematical calculations to be performed in the solution of a quadratic equation consist of evaluating the coefficients which are variables dependent upon the parameter set under consideration and then using the quadratic formula to evaluate the neon current. Since in the present problem the argument of the square root is always positive and greater than the coefficient B, only the positive root need be calculated. Logical tests to be performed consist of determining acceptable circuit designs by employing the given circuit specifications as test criteria. Other logical tests are used in determining maximum - minimum values and program loop completions.

The transformation from mathematical to FORTRAN statements is accomplished next. Input to the 1604 digital computer can be by either punched cards or magnetic tape. Utilization of punched cards is superior at this time as cards which are in error can be easily replaced, and additions or deletions made as necessary. The complete program in FORTRAN

appears as in figure 9. Each line in the program represents a single punched IBM card. If this same program had been done in machine language, these thirty odd FORTRAN cards would be replaced by about five hundred machine language cards.

If the FORTRAN program when placed in memory is complete and logical, the program will compile. If compilation is not accomplished an error printout will result. The error printout categorizes the errors that have escaped detection by the programmer and lists these errors by FORTRAN statement number. When the error is recognized alterations to the punched cards can easily be accomplished and the program compilation retried until successful. Writing output on magnetic tape is a separate entity from the computer proper and occurs simultaneously with computer calculations. The magnetic tape in turn is read out on an off line printer so as to conserve computer time. An example of the digital computer printout as obtained from the off line printer appears as in figure 10.

Prior to proceeding with these digital computer answers a mathematical check is required to see whether the problem is being solved correctly. A desk calculator should be used rather than a slide rule to obtain enough significant figures for comparison purposes. When a calculator check has been made for one set of parameters and dependability of the computer program proven, then the accuracy of the remaining output can be relied upon. A similar FORTRAN program for the uncompensated neon photoconductor circuit is illustrated in figure 11. This program is needed for a comparison of its results with those of the compensated circuit.

```

PROGRAM BASIC
DIMENSION V(3),R1(10),R2(17),T(4),Z(4)
100 FORMAT(3F4.0)
READ 100(V(I),I=1,3)
200 FORMAT(10F7.0)
READ 200(R1(J),J=1,10)
300 FORMAT(11F7.0)
READ 300(R2(K),K=1,17)
400 FORMAT(4F3.0)
READ 400(T(L),L=1,4)
500 FORMAT(4F3.1)
READ 500(Z(M),M=1,4)
DO 16 I=1,3
DO 15 M=1,4
DO 14 J=1,10
DO 13 K=1,17
CMIN1=3.
CMAX1=1.
DO 12 L=1,4
A = (R1(J)*R2(K)+2.11E3*Z(M)*R2(K)*EXPF(.0183*T(L)))/1.E6
E = 2.11E3*Z(M)*EXPF(.0183*T(L))*(V(I)+(2.*R1(J))/1.E3)+V(I)*R1(J)
F = 8.904E3*Z(M)*Z(M)*EXPF(.0366*T(L))+R2(K)*(V(I)-300.)
B = (E+F)/1.E3
C = 4.22*Z(M)*EXPF(.0183*T(L))*(V(I)-300.)
CTWO = (-B+SQRTF((B*B)-(4.*A*C)))/(2.*A)
IF (CTWO-1.5)13,13,8
8 IF (CTWO-2.5)9,13,13
9 CMAX1=MAX1F(CMAX1,CTWO)
CMIN1=MIN1F(CMIN1,CTWO)
12 CONTINUE
DELTA=CMAX1-CMIN1
600 FORMAT(F5.0,2F13.0,F8.1,F13.5)
WRITE OUTPUT TAPE 4,600,V(I),R1(J),R2(K),Z(M),DELTA
13 CONTINUE
14 CONTINUE
15 CONTINUE
16 CONTINUE
END FILE 4
PAUSE 1
END
END

```

60. 80.100.
40000. 50000. 60000. 70000. 80000. 90000. 100000. 110000. 120000. 130000.
200000. 220000. 240000. 260000. 280000. 300000. 320000. 340000. 360000. 380000. 400000.
420000. 440000. 460000. 480000. 500000. 520000.
25.35.45.55.
2.51.71.0 .4

| Vm. | R1 | R2 | Z | DELTA |
|-----|---------|---------|-----|--------|
| 60. | 110000. | 200000. | 2.5 | .08892 |
| 60. | 110000. | 220000. | 2.5 | .09080 |
| 60. | 110000. | 240000. | 2.5 | .09217 |
| 60. | 110000. | 260000. | 2.5 | .09324 |
| 60. | 110000. | 280000. | 2.5 | .09409 |
| 60. | 110000. | 300000. | 2.5 | .09478 |
| 60. | 110000. | 320000. | 2.5 | .09534 |
| 60. | 110000. | 340000. | 2.5 | .09580 |
| 60. | 110000. | 360000. | 2.5 | .09619 |
| 60. | 110000. | 380000. | 2.5 | .09652 |
| 60. | 110000. | 400000. | 2.5 | .09680 |
| 60. | 110000. | 420000. | 2.5 | .09704 |
| 60. | 110000. | 440000. | 2.5 | .09725 |
| 60. | 110000. | 460000. | 2.5 | .09743 |
| 60. | 110000. | 480000. | 2.5 | .09759 |
| 60. | 110000. | 500000. | 2.5 | .09774 |
| 60. | 110000. | 520000. | 2.5 | .09786 |
| 60. | 120000. | 200000. | 2.5 | .07366 |
| 60. | 120000. | 220000. | 2.5 | .07559 |
| 60. | 120000. | 240000. | 2.5 | .07707 |
| 60. | 120000. | 260000. | 2.5 | .07822 |
| 60. | 120000. | 280000. | 2.5 | .07913 |
| 60. | 120000. | 300000. | 2.5 | .07987 |
| 60. | 120000. | 320000. | 2.5 | .08047 |
| 60. | 120000. | 340000. | 2.5 | .08097 |
| 60. | 120000. | 360000. | 2.5 | .08139 |
| 60. | 120000. | 380000. | 2.5 | .08174 |
| 60. | 120000. | 400000. | 2.5 | .08205 |
| 60. | 120000. | 420000. | 2.5 | .08230 |
| 60. | 120000. | 440000. | 2.5 | .08253 |
| 60. | 120000. | 460000. | 2.5 | .08273 |
| 60. | 120000. | 480000. | 2.5 | .08290 |
| 60. | 120000. | 500000. | 2.5 | .08305 |
| 60. | 120000. | 520000. | 2.5 | .08318 |
| 60. | 130000. | 300000. | 2.5 | .06957 |
| 60. | 130000. | 380000. | 2.5 | .06995 |
| 60. | 130000. | 400000. | 2.5 | .07027 |
| 60. | 130000. | 420000. | 2.5 | .07055 |
| 60. | 130000. | 440000. | 2.5 | .07079 |
| 60. | 130000. | 460000. | 2.5 | .07100 |

PROGRAM
BASIC

Fig. 10

```

PROGRAM COMPA
DIMENSION V(3),R1(10),R2(17),T(4),Z(4)
100 FORMAT(3F4.0)
READ 100(V(I),I=1,3)
200 FORMAT (10F7.0)
READ 200 (R1(J), J=1,10)
300 FORMAT (11F7.0)
READ 300(R2(K),K=1,17)
400 FORMAT (4F3.0)
READ 400 (T(L), L=1,4)
500 FORMAT (4F3.1)
READ 500 (Z(M),M=1,4)
DO 16 I=1,3
DO 15 M=1,4
DO 14 J = 1, 10
DO 13 K=1, 17
CMIN1=3.
CMAX1=1.
DO 12 L = 1,4
OCTWO=((300.-V(I))/(R1(J)+2.11E3*Z(M)*EXPF(.0183*T(L)))-(V(I)/
1R2(K)))*1.E3
8 IF (CTWO-1.5)13,13,8
9 CMAX1=MAX1F(CMAX1,CTWO)
CMIN1=MIN1F(CMIN1,CTWO)
12 CONTINUE
DELTA=CMAX1-CMIN1
600 FORMAT(F5.0,2F13.0,F8.1,F13.5)
WRITE OUTPUT TAPE 4,600,V(I),R1(J),R2(K),Z(M),DELTA
13 CONTINUE
14 CONTINUE
15 CONTINUE
16 CONTINUE
END FILE 4
PAUSE 1
END

```

```

60. 80.100.
40000. 50000. 60000. 70000. 80000. 90000.100000.110000.120000.130000.
200000.220000.240000.260000.280000.300000.320000.340000.360000.380000.400000.
420000.440000.460000.480000.500000.520000.
2.51.71.0 .4

```

The main computer program illustrates one of the prime advantages of the digital computer in evaluating circuits which have known parameters of the type requiring incremental analysis. The flow chart of the main program called neon or light which uses the hyperbola or second order approximation is illustrated in figure 12. Here again every possible combination of circuit parameters are systematically tested to determine if they meet specifications. With each set of design parameters the known parameters requiring increments are combined in every possible manner. If every combination of these incremental known parameters passes all logic tests with one set of design parameters, then this combination of design parameters is recorded on magnetic tape along with the maximum and minimum neon current for the particular voltage. This signifies that the present design parameters being considered have produced a circuit which has successfully passed all of the logic tests for the unpredictable known parameters Z and T. The FORTRAN programs for neon and light are depicted in figures 13 and 14.

Each set of output data in figure 15 is a successful design combination. In other words for a neon tube maintaining voltage of 60 volts, a series resistance of 90 K ohms, and a shunt resistance of 200 K ohms, the neon current will only vary between 2.32944 and 2.01816 milliamperes for the hyperbola approximation and between 2.32938 and 2.01802 milliamperes for the second order approximation. This variation in neon current includes any variation in the characteristics of the photoconductor due to temperature or light intensity within the assumed possible limits. The last two columns of the output data, maximum and minimum neon currents for the chosen design parameters, have no immediate use in the synthesis of the circuit. Since these currents had to be calculated to evaluate the success of the circuit, it was an easy task to store them in memory and print out the maximum and minimum values for each design parameter set.

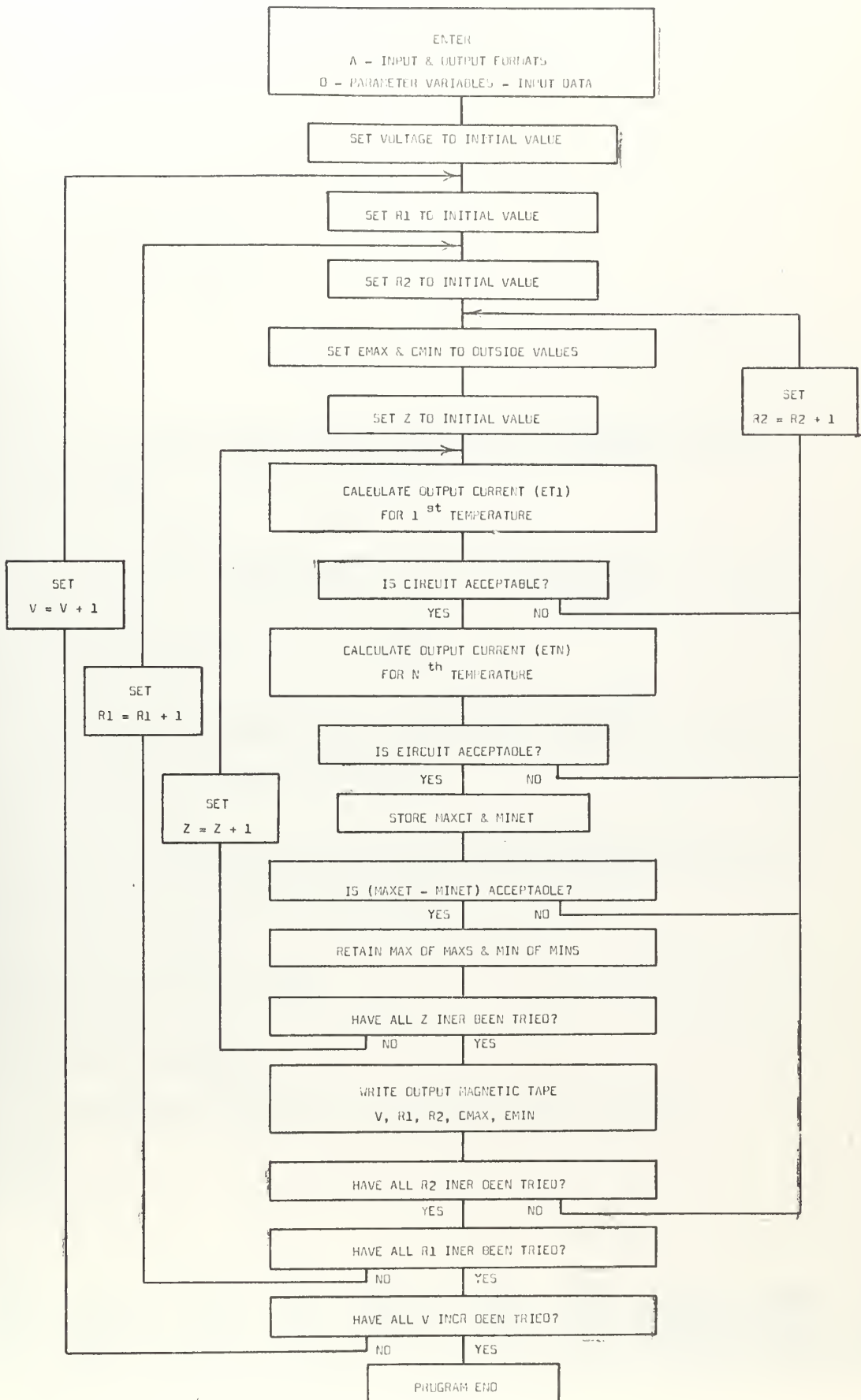

Fig. 12

```

PROGRAM NEON
DIMENSION V(3),R1(21),R2(34),Z(5)
100 FORMAT(3F4.0)
READ 100(V(I),I=1,3)
200 FORMAT (11F7.0)
READ 200 (R1(J),J=1,21)
READ 200 (R2(K),K=1,34)
500 FORMAT (5F3.1)
READ 500 (Z(M),M=1,5)
DO 16 I=1,3
DO 15 J=1,21
DO 14 K=1,34
CMIN1=3.
CMAX1=1.
DO 13 M=1,5
A1=(R1(J)*R2(K)+2.11E3*Z(M)*R2(K)*EXPF(.4575))/1.E6
E1=2.11E3*Z(M)*EXPF(.4575)*(V(I)+(2.*R1(J)))/1.E3)+V(I)*R1(J)
F1=8.904E3*Z(M)*Z(M)*EXPF(.9150)+R2(K)*(V(I)-300.)
B1=(E1+F1)/1.E3
C1=4.22*Z(M)*EXPF(.4575)*(V(I)-300.)
CT1=(-B1+SQRTF((B1*B1)-(4.*A1*C1)))/(2.*A1)
4 IF(CT1-1.5) 14,4,4
5 IF(CT1-2.5) 5,5,14
A2=(R1(J)*R2(K)+2.11E3*Z(M)*R2(K)*EXPF(.6405))/1.E6
E2=2.11E3*Z(M)*EXPF(.6405)*(V(I)+(2.*R1(J)))/1.E3)+V(I)*R1(J)
F2=8.904E3*Z(M)*Z(M)*EXPF(1.281)+R2(K)*(V(I)-300.)
B2=(E2+F2)/1.E3
C2=4.22*Z(M)*EXPF(.6405)*(V(I)-300.)
CT2=(-B2+SQRTF((B2*B2)-(4.*A2*C2)))/(2.*A2)
6 IF(CT2-1.5) 14,6,6
7 IF(CT2-2.5) 7,7,14
A3=(R1(J)*R2(K)+2.11E3*Z(M)*R2(K)*EXPF(.8235))/1.E6
E3=2.11E3*Z(M)*EXPF(.8235)*(V(I)+(2.*R1(J)))/1.E3)+V(I)*R1(J)
F3=8.904E3*Z(M)*Z(M)*EXPF(1.647)+R2(K)*(V(I)-300.)
B3=(E3+F3)/1.E3
C3=4.22*Z(M)*EXPF(.8235)*(V(I)-300.)
CT3=(-B3+SQRTF((B3*B3)-(4.*A3*C3)))/(2.*A3)
8 IF(CT3-1.5) 14,8,8
9 IF(CT3-2.5) 9,9,14
A4=(R1(J)*R2(K)+2.11E3*Z(M)*R2(K)*EXPF(1.0065))/1.E6
E4=2.11E3*Z(M)*EXPF(1.0065)*(V(I)+(2.*R1(J)))/1.E3)+V(I)*R1(J)
F4=8.904E3*Z(M)*Z(M)*EXPF(2.013)+R2(K)*(V(I)-300.)
B4=(E4+F4)/1.E3
C4=4.22*Z(M)*EXPF(1.0065)*(V(I)-300.)
CT4=(-B4+SQRTF((B4*B4)-(4.*A4*C4)))/(2.*A4)
10 IF(CT4-1.5) 14,10,10
11 IF(CT4-2.5) 11,11,14
CMAA=MAX1F(CT1,CT2,CT3,CT4)
CMIN=MIN1F(CT1,CT2,CT3,CT4)
DELTA=CMAA-CMIN
12 IF(DELTA-.15) 12,12,14
CMAX1=MAX1F(CMAA,CMAX1)
CMIN1=MIN1F(CMIN,CMIN1)
13 CONTINUE
600 FORMAT(F6.0,2F13.0,2F13.5)
WRITE OUTPUT TAPE 4,600, V(I),R1(J),R2(K),CMAX1,CMIN1
14 CONTINUE
15 CONTINUE
16 CONTINUE
END FILE 4
PAUSE 1
END
END

```

```

60. 80.100.
40000. 50000. 60000. 70000. 75000. 80000. 82000. 84000. 86000. 88000. 90000.
92000. 94000. 96000. 98000. 100000. 105000. 110000. 115000. 120000. 130000.
40000. 60000. 80000. 100000. 120000. 140000. 160000. 180000. 200000. 220000. 240000.
260000. 280000. 300000. 320000. 340000. 360000. 380000. 400000. 420000. 440000. 460000.
480000. 500000. 520000. 540000. 560000. 580000. 600000. 620000. 640000. 660000. 680000.
700000.
.4 .91.41.92.5

```

```

PROGRAM LIGH
DIMENSION V(5),R1(21),R2(34),Z(5)
100 FORMAT (5F4.0)
READ 100 (V(I), I=1,5)
200 FORMAT (11F7.0)
READ 200 (R1(J),J=1,21)
READ 200 (R2(K),K=1,34)
500 FORMAT (5F3.1)
READ 500 (Z(M),M=1,5)
DO 16 I=1,5
DO 15 J=1,21
DO 14 K=1,34
CMIN1=3.
CMAX1=1.
DO 13 M=1,5
O A1=2.11*Z(M)*EXPF(.4575)*(1.42*R2(K)+530.2*Z(M)*EXPF(.4575)+.25118
1*R1(J))+1.42*R1(J)*R2(K)/1.E3
E1=2795.6*Z(M)*EXPF(.4575)*(R1(J)/1.E3+2.11*Z(M)*EXPF(.4575)-(300.
1-V(I))/75.273)-R1(J)*R2(K)/1.E3
F1=2.11*Z(M)*EXPF(.4575)*(1.42E3*V(I)-R2(K))+1.42*(V(I)*R1(J)-300.
1*R2(K)+V(I)*R2(K))
B1=E1+F1
C1=Z(M)*EXPF(.4575)*(2795.6*(V(I)-300.)-2.11E3*
1V(I))+(300.-V(I))*R2(K)-V(I)*R1(J)
CT1=(-B1+SQRTF((B1*B1)-(4.*A1*C1)))/(2.*A1)
IF(CT1-1.5) 14,4,4
4 IF(CT1-2.5) 5,5,14
5 A2=2.11*Z(M)*EXPF(.6405)*(1.42*R2(K)+530.2*Z(M)*EXPF(.6405)+.25118
1*R1(J))+1.42*R1(J)*R2(K)/1.E3
E2=2795.6*Z(M)*EXPF(.6405)*(R1(J)/1.E3+2.11*Z(M)*EXPF(.6405)-(300.
1-V(I))/75.273)-R1(J)*R2(K)/1.E3
F2=2.11*Z(M)*EXPF(.6405)*(1.42E3*V(I)-R2(K))+1.42*(V(I)*R1(J)-300.
1*R2(K)+V(I)*R2(K))
B2=E2+F2
C2=Z(M)*EXPF(.6405)*(2795.6*(V(I)-300.)-2.11E3*
1V(I))+(300.-V(I))*R2(K)-V(I)*R1(J)
CT2=(-B2+SQRTF((B2*B2)-(4.*A2*C2)))/(2.*A2)
IF(CT2-1.5) 14,6,6
6 IF(CT2-2.5) 7,7,14
7 A3=2.11*Z(M)*EXPF(.8235)*(1.42*R2(K)+530.2*Z(M)*EXPF(.8235)+.25118
1*R1(J))+1.42*R1(J)*R2(K)/1.E3
E3=2795.6*Z(M)*EXPF(.8235)*(R1(J)/1.E3+2.11*Z(M)*EXPF(.8235)-(300.
1-V(I))/75.273)-R1(J)*R2(K)/1.E3
F3=2.11*Z(M)*EXPF(.8235)*(1.42E3*V(I)-R2(K))+1.42*(V(I)*R1(J)-300.
1*R2(K)+V(I)*R2(K))
B3=E3+F3
C3=Z(M)*EXPF(.8235)*(2795.6*(V(I)-300.)-2.11E3*
1V(I))+(300.-V(I))*R2(K)-V(I)*R1(J)
CT3=(-B3+SQRTF((B3*B3)-(4.*A3*C3)))/(2.*A3)
IF(CT3-1.5) 14,8,8
8 IF(CT3-2.5) 9,9,14
9 A4=2.11*Z(M)*EXPF(1.0065)*(1.42*R2(K)+530.2*Z(M)*EXPF(1.0065)+.25118
1*R1(J))+1.42*R1(J)*R2(K)/1.E3
E4=2795.6*Z(M)*EXPF(1.0065)*(R1(J)/1.E3+2.11*Z(M)*EXPF(1.0065)-(30
10.-V(I))/75.273)-R1(J)*R2(K)/1.E3
F4=2.11*Z(M)*EXPF(1.0065)*(1.42E3*V(I)-R2(K))+1.42*(V(I)*
1R1(J)-300.*R2(K)+V(I)*R2(K))
B4=E4+F4
C4=Z(M)*EXPF(1.0065)*(2795.6*(V(I)-300.)-2.11E3*
1V(I))+(300.-V(I))*R2(K)-V(I)*R1(J)
CT4=(-B4+SQRTF((B4*B4)-(4.*A4*C4)))/(2.*A4)
IF(CT4-1.5) 14,10,10
10 IF(CT4-2.5) 11,11,14
11 CMAA=MAXIF(CT1,CT2,CT3,CT4)
CMIN=MINIF(CT1,CT2,CT3,CT4)
DELTA=CMAA-CMIN
IF(DELTA-.15) 12,12,14
12 CMAX1=MAXIF(CMAA,CMAX1)
CMIN1=MINIF(CMIN,CMIN1)
13 CONTINUE
600 FORMAT(F4.0,2F13.0,2F13.5)
WRITE OUTPUT TAPE 4,600, V(I),R1(J),R2(K),CMAX1,CMIN1
14 CONTINUE
15 CONTINUE
16 CONTINUE
END FILE 4
PAUSE 1
END
END

```

Fig. 14

| Vm. | R1 | R2 | C MAX 1 | C MIN 1 |
|-------|--------|---------|---------|---------|
| 60. | 80000. | 60000. | 1.71117 | 1.52517 |
| 60. | 80000. | 50000. | 1.75417 | 1.57117 |
| 60. | 80000. | 40000. | 2.02011 | 1.72625 |
| 60. | 80000. | 30000. | 2.15150 | 1.77225 |
| 60. | 80000. | 20000. | 2.35157 | 1.75532 |
| 60. | 80000. | 160000. | 2.31424 | 1.92705 |
| 60. | 80000. | 140000. | 2.34551 | 2.03403 |
| 60. | 80000. | 250000. | 2.37222 | 2.06263 |
| 60. | 80000. | 235000. | 2.41512 | 2.07502 |
| 60. | 80000. | 240000. | 2.4769 | 2.19651 |
| 60. | 88000. | 260000. | 2.45775 | 2.12379 |
| 60. | 88000. | 280000. | 2.47310 | 2.13352 |
| 60. | 80000. | 300000. | 2.47727 | 2.15157 |
| 60. | 80000. | 320000. | 2.49765 | 2.16301 |
| 60. | 90000. | 60000. | 1.65390 | 1.53657 |
| 60. | 90000. | 70000. | 1.72073 | 1.62067 |
| 60. | 90000. | 100000. | 2.05542 | 1.74172 |
| 60. | 90000. | 120000. | 2.13262 | 1.75552 |
| 60. | 90000. | 150000. | 2.17233 | 1.71130 |
| 60. | 90000. | 160000. | 2.25542 | 1.75522 |
| 60. | 90000. | 130000. | 2.22653 | 1.77267 |
| 60. | 90000. | 200000. | 2.37244 | 2.01110 |
| 60. | 90000. | 220000. | 2.35640 | 2.04135 |
| 60. | 90000. | 240000. | 2.37222 | 2.06172 |
| 60. | 90000. | 260000. | 2.39724 | 2.07707 |
| 60. | 90000. | 280000. | 2.41022 | 2.07371 |
| 60. | 90000. | 300000. | 2.42246 | 2.10687 |
| 60. | 90000. | 320000. | 2.44017 | 2.11827 |
| 60. | 90000. | 340000. | 2.45122 | 2.12743 |
| <hr/> | | | | |
| 60. | 88000. | 60000. | 1.71308 | 1.52092 |
| 60. | 88000. | 50000. | 1.74913 | 1.72751 |
| 60. | 88000. | 100000. | 2.07397 | 1.82652 |
| 60. | 88000. | 120000. | 2.17145 | 1.89267 |
| 60. | 88000. | 140000. | 2.26146 | 1.95534 |
| 60. | 88000. | 160000. | 2.31415 | 1.99820 |
| 60. | 88000. | 130000. | 2.35523 | 2.03382 |
| 60. | 88000. | 200000. | 2.37816 | 2.06240 |
| 60. | 88000. | 220000. | 2.41514 | 2.08619 |
| 60. | 88000. | 240000. | 2.43765 | 2.10630 |
| 60. | 88000. | 260000. | 2.45671 | 2.12350 |
| 60. | 88000. | 280000. | 2.47306 | 2.13339 |
| 60. | 88000. | 300000. | 2.48724 | 2.15140 |
| 60. | 88000. | 320000. | 2.49966 | 2.16286 |
| 60. | 90000. | 60000. | 1.65553 | 1.55319 |
| 60. | 90000. | 80000. | 1.82035 | 1.68654 |
| 60. | 90000. | 100000. | 2.03541 | 1.78491 |
| 60. | 90000. | 120000. | 2.13273 | 1.85637 |
| 60. | 90000. | 140000. | 2.20273 | 1.91150 |
| 60. | 90000. | 160000. | 2.25542 | 1.95485 |
| 60. | 90000. | 180000. | 2.29646 | 1.98958 |
| 60. | 90000. | 200000. | 2.32232 | 2.01302 |
| 60. | 90000. | 220000. | 2.34635 | 2.04172 |
| 60. | 90000. | 240000. | 2.37235 | 2.06176 |
| 60. | 90000. | 260000. | 2.37721 | 2.07321 |
| 60. | 90000. | 280000. | 2.41425 | 2.09376 |
| 60. | 90000. | 300000. | 2.42243 | 2.10673 |
| 60. | 90000. | 320000. | 2.44024 | 2.11117 |
| 60. | 90000. | 340000. | 2.45130 | 2.12732 |
| 60. | 90000. | 360000. | 2.46154 | 2.13737 |
| 60. | 90000. | 380000. | 2.47025 | 2.14554 |
| 60. | 90000. | 400000. | 2.47812 | 2.15821 |
| 60. | 90000. | 420000. | 2.48522 | 2.15260 |
| 60. | 90000. | 440000. | 2.49218 | 2.16570 |
| 60. | 90000. | 460000. | 2.49751 | 2.17122 |
| 60. | 92000. | 50000. | 1.67271 | 1.57117 |

PROGRAM
NEON

PROGRAM
LIGHT

Fig. 15

These maximum and minimum neon currents do have value for the analyst after the design has been chosen, and all that remains is the determination of the particular maintaining voltage in any one circuit. This will be of immediate use provided that the neon tube voltage is close to one of the increments of voltage used in the digital computer program; in other cases, interpolation is required.

The digital computer program which is flow charted in figure 12 and represented in FORTRAN statements in figure 13 has a computer running time of 8 minutes and 30 seconds. This output data still requires interpretation, evaluation and presentation in a useable manner before it can be considered as a true design asset.

6. Interpretation of Digital Computer Data

Prior to an extensive interpretation of the digital computer printout, it is most advantageous to consider the neon photoconductor circuit on a simpler basis. Let us make the following assumptions: 1) The maintaining voltage of the neon tube is fixed at 60 volts. 2) The known parameter β has only one value namely, 2.5. 3) Temperature variations are such that the ambient temperature will vary between 25° C and 55° C. With these three assumptions two circuits will be considered, one with compensation and one without the compensating shunt photoconductor. The printout for the compensated and uncompensated circuits are shown in figure 16. These two printouts are of the same format as the main program except that the maximum and minimum currents are now solely attributed to temperature variations.

A plot of the design parameters R_2 versus R_1 , which meet output specifications, namely neon current between 1.5 and 2.5 milliamperes, is constructed for both the compensated and uncompensated photoconductor circuits. These plots are figures 17 and 18 respectively. The uncompensated photoconductor circuit has a minimum value of shunt resistance. This constraint is brought about by the physical requirement of a sufficient voltage drop across the shunt resistance to fire the neon tube. The compensated photoconductor circuit has a dark photoconductive resistance in series with the shunt resistance prior to firing which is in the megohm region. Therefore, only the uncompensated circuit requires a minimum value of shunt resistance. Assuming a firing voltage of 135 volts which is an observed average value, then the following calculations for the minimum value of R_2 at $I = 2.5$ apply:

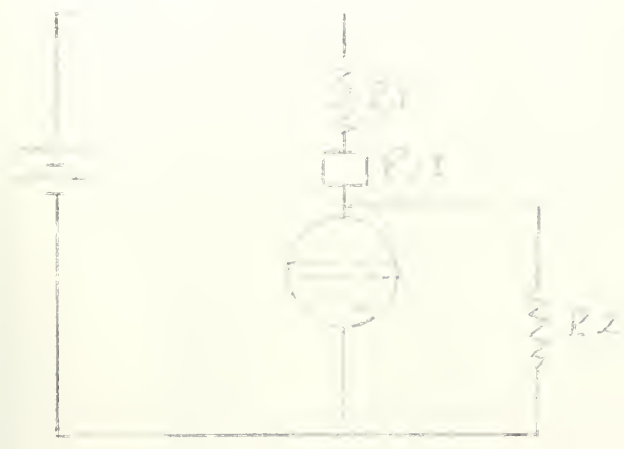

Figure 19

For neon to fire $V_m \geq 135$ volts

$$V_m = 300 \frac{R_2}{R_1 + R_{p1} + R_2}$$

$$\frac{R_2}{R_1 + R_{p1} + R_2} \geq \frac{135}{300} \geq .45$$

$$R_{p1} = 2.11 \times 10^3 \pm e^{(10000/T)}$$

For $T = 25^\circ C$

$$x = 2.5$$

$$R_{p1} = 8.8 \times 10^3$$

$$R_2 = .818 R_1 + 6.78 \times 10^3 \text{ which is a linear relationship between}$$

R_2 min and R_1

Table

| | | | | | | |
|----|-------|-------|-------|-------|-------|--------|
| R1 | KOHMS | 50 | 60 | 80 | 110 | 130 |
| R2 | KOHMS | 47.68 | 55.88 | 72.28 | 96.78 | 112.93 |

The points when plotted produce the dashed line in figure 18.

| Vm. | R1 | R2 | Z | DELTA |
|-----|---------|---------|-----|--------|
| 60. | 80000. | 200000. | 2.5 | .17543 |
| 60. | 80000. | 220000. | 2.5 | .17543 |
| 60. | 80000. | 240000. | 2.5 | .17543 |
| 60. | 80000. | 260000. | 2.5 | .17543 |
| 60. | 90000. | 200000. | 2.5 | .14250 |
| 60. | 90000. | 220000. | 2.5 | .14250 |
| 60. | 90000. | 240000. | 2.5 | .14250 |
| 60. | 90000. | 260000. | 2.5 | .14250 |
| 60. | 90000. | 280000. | 2.5 | .14250 |
| 60. | 90000. | 300000. | 2.5 | .14250 |
| 60. | 90000. | 320000. | 2.5 | .14250 |
| 60. | 90000. | 340000. | 2.5 | .14250 |
| 60. | 90000. | 360000. | 2.5 | .14250 |
| 60. | 90000. | 380000. | 2.5 | .14250 |
| 60. | 90000. | 400000. | 2.5 | .14250 |
| 60. | 90000. | 420000. | 2.5 | .14250 |
| 60. | 90000. | 440000. | 2.5 | .14250 |
| 60. | 90000. | 460000. | 2.5 | .14250 |
| 60. | 90000. | 480000. | 2.5 | .14250 |
| 60. | 90000. | 500000. | 2.5 | .14250 |
| 60. | 90000. | 520000. | 2.5 | .14250 |
| 60. | 100000. | 200000. | 2.5 | .11804 |
| 60. | 100000. | 220000. | 2.5 | .11804 |
| 60. | 100000. | 240000. | 2.5 | .11804 |
| 60. | 100000. | 260000. | 2.5 | .11804 |
| 60. | 100000. | 280000. | 2.5 | .11804 |
| 60. | 100000. | 300000. | 2.5 | .11804 |
| 60. | 100000. | 320000. | 2.5 | .11804 |
| 60. | 100000. | 340000. | 2.5 | .11804 |
| 60. | 100000. | 360000. | 2.5 | .11804 |
| 60. | 100000. | 380000. | 2.5 | .11804 |
| 60. | 100000. | 400000. | 2.5 | .11804 |
| 60. | 100000. | 420000. | 2.5 | .11804 |
| 60. | 100000. | 440000. | 2.5 | .11804 |
| 60. | 100000. | 460000. | 2.5 | .11804 |
| 60. | 100000. | 480000. | 2.5 | .11804 |
| 60. | 100000. | 500000. | 2.5 | .11804 |
| 60. | 100000. | 520000. | 2.5 | .11804 |

PROGRAM
COMPA

| | | | | |
|-----|---------|---------|-----|--------|
| 60. | 80000. | 200000. | 2.5 | .16750 |
| 60. | 80000. | 220000. | 2.5 | .16878 |
| 60. | 80000. | 240000. | 2.5 | .15205 |
| 60. | 80000. | 260000. | 2.5 | .17052 |
| 60. | 90000. | 200000. | 2.5 | .13356 |
| 60. | 90000. | 220000. | 2.5 | .13520 |
| 60. | 90000. | 240000. | 2.5 | .15638 |
| 60. | 90000. | 260000. | 2.5 | .13722 |
| 60. | 90000. | 280000. | 2.5 | .13201 |
| 60. | 90000. | 300000. | 2.5 | .13252 |
| 60. | 90000. | 320000. | 2.5 | .13907 |
| 60. | 90000. | 340000. | 2.5 | .13945 |
| 60. | 90000. | 360000. | 2.5 | .13979 |
| 60. | 90000. | 380000. | 2.5 | .14007 |
| 60. | 90000. | 400000. | 2.5 | .14031 |
| 60. | 90000. | 420000. | 2.5 | .14051 |
| 60. | 90000. | 440000. | 2.5 | .14069 |
| 60. | 90000. | 460000. | 2.5 | .14085 |
| 60. | 90000. | 480000. | 2.5 | .14098 |
| 60. | 90000. | 500000. | 2.5 | .14110 |
| 60. | 90000. | 520000. | 2.5 | .14121 |
| 60. | 100000. | 200000. | 2.5 | .10242 |
| 60. | 100000. | 220000. | 2.5 | .11010 |
| 60. | 100000. | 240000. | 2.5 | .11157 |
| 60. | 100000. | 260000. | 2.5 | .11237 |
| 60. | 100000. | 280000. | 2.5 | .11315 |
| 60. | 100000. | 300000. | 2.5 | .11372 |
| 60. | 100000. | 320000. | 2.5 | .11431 |
| 60. | 100000. | 340000. | 2.5 | .11473 |
| 60. | 100000. | 360000. | 2.5 | .11502 |
| 60. | 100000. | 380000. | 2.5 | .11540 |
| 60. | 100000. | 400000. | 2.5 | .11566 |
| 60. | 100000. | 420000. | 2.5 | .11583 |
| 60. | 100000. | 440000. | 2.5 | .11607 |
| 60. | 100000. | 460000. | 2.5 | .11624 |
| 60. | 100000. | 480000. | 2.5 | .11652 |
| 60. | 100000. | 500000. | 2.5 | .11652 |
| 60. | 100000. | 520000. | 2.5 | .11664 |

PROGRAM
BASIC

Fig. 16

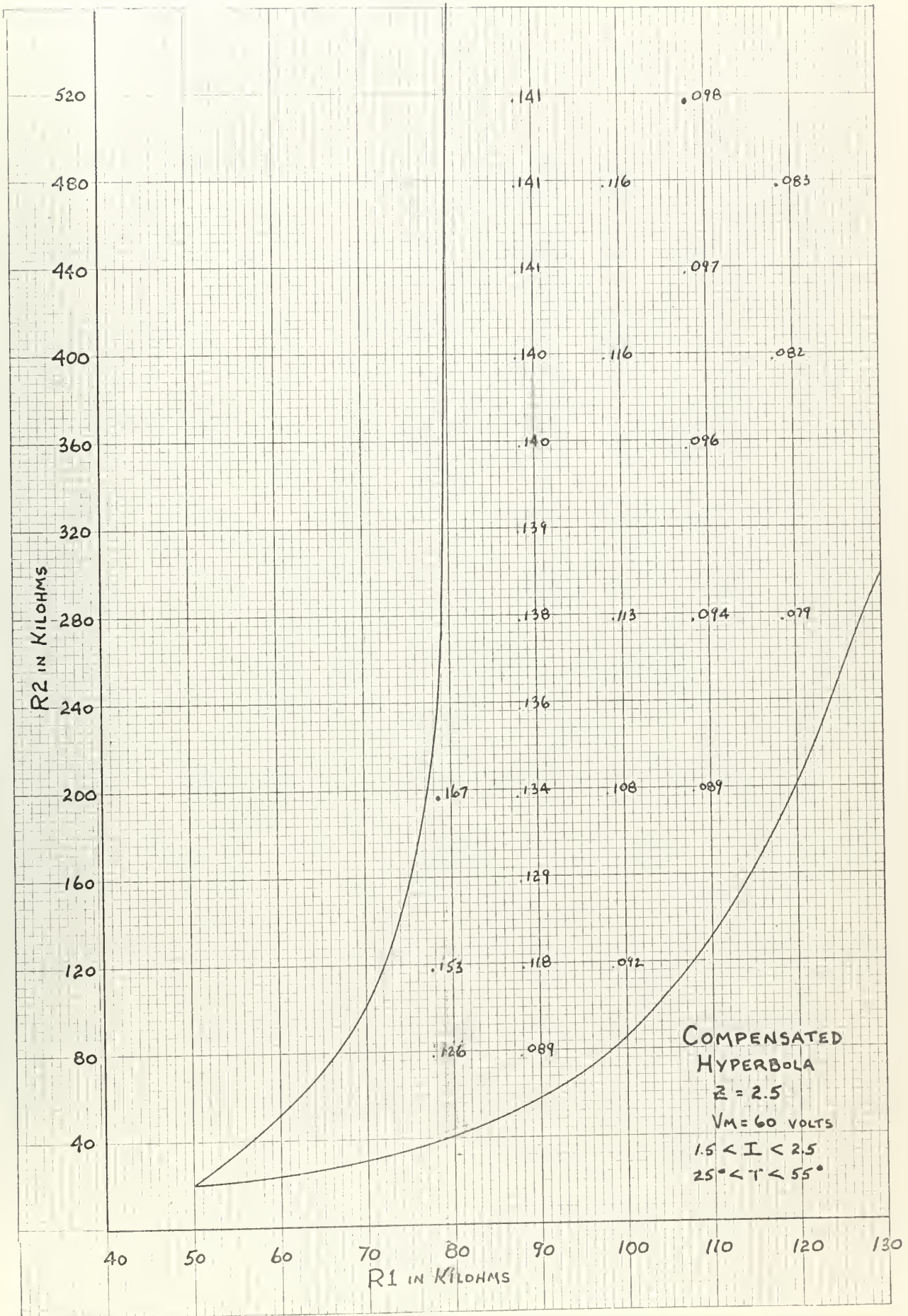

Fig. 17

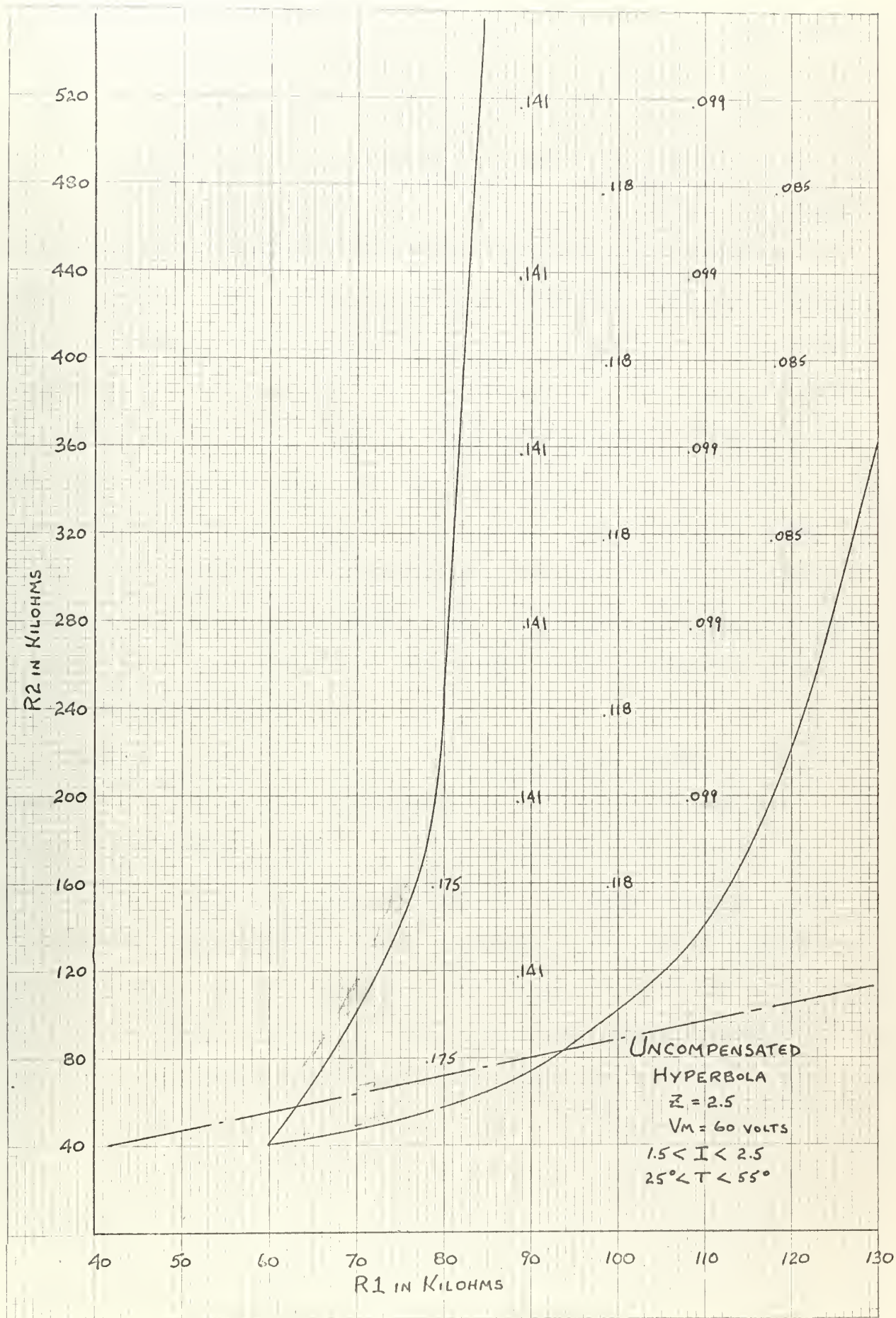

Fig. 18

A mapping procedure is employed in each plot in order to observe the effect of the change in neon current due only to temperature variations. These numbers within the area represent the difference between the maximum and minimum neon current in milliamperes for that particular set of design parameters (R_1 and R_2). A comparison of the two plots reveals that compensation is actually achieved by insertion of the shunt photoconductor. A second conclusion that can readily be made is that for a particular value of R_1 in the uncompensated area plot the variation in current is constant and independent of the value of the shunt resistance R_2 . This constant value is also the limiting value which the compensated area plot approaches as the shunt resistance becomes infinite. Analytically this last result could have been foreseen since for large values of shunt resistance the effect of the compensating photoconductor on the total series resistance diminishes and eventually approaches zero. This simple neon photoconductor circuit will be employed later in this section as an illustrative example of best design procedure.

The digital computer printout of the main program whether it is the hyperbolic or "second order" approximation is of the same format (See Figure 15 for printout format). For each value of series resistance R_1 , those values of shunt resistance R_2 which mark the upper and lower limits of successful circuit combinations in the printout are plotted on graph paper producing areas. In the case of the hyperbola only two of these plots are necessary, one for the lowest maintaining voltage encountered and one for the highest maintaining voltage since $\frac{\partial I_n}{\partial V}$ is always negative. The "second order" approximation expression is more involved and it cannot be mathematically proven to have a negative $\frac{\partial I_n}{\partial V}$ for all design sets to be considered. In this case increments of maintaining voltage were used in the digital computer program and as many plots as

voltage increments are necessary. Each area plot is a good design for a particular maintaining voltage, and all Z's and all T's. In both approximations the resulting areas, whether two as in the case of the hyperbola or many as in the second order, can now be overlapped to produce a final area which is common to all of the individual areas. This final area if it exists has satisfied all of the restrictions imposed on temperature, Z, maintaining voltage and output neon current. The resultant area for the hyperbolic approximation is shown in figure 20.

In order to observe the effects of more restrictive specifications, the printout data of both the hyperbola and "second order" approximations was plotted using those upper and lower limits of the shunt resistance that yielded an output neon current between 1.8 and 2.2 milliamperes. After having plotted the individual area plots, the overlapping procedure was employed to find the common area. A common area is non-existent. If this specification of output current had been used vice 1.5 - 2.5 milliamperes, then the absence of an area indicates that there is no design parameter combination that is satisfactory for the entire maintaining voltage range.

The amount of compensation effected can be seen by analysis of the difference in maximum and minimum neon currents due only to temperature variations. Refer to the simple example mentioned previously where the maintaining voltage was fixed at 60 volts and parameter Z fixed at 2.5 (See figure 17). The mapped points in the interior of the area plot in figure 17 represent the difference between the maximum and minimum neon currents in milliamperes due solely to temperature variation for that particular set of design parameters (F1 and R2). Inspection of the plot reveals that the deviation due to temperature for the same value of R2,

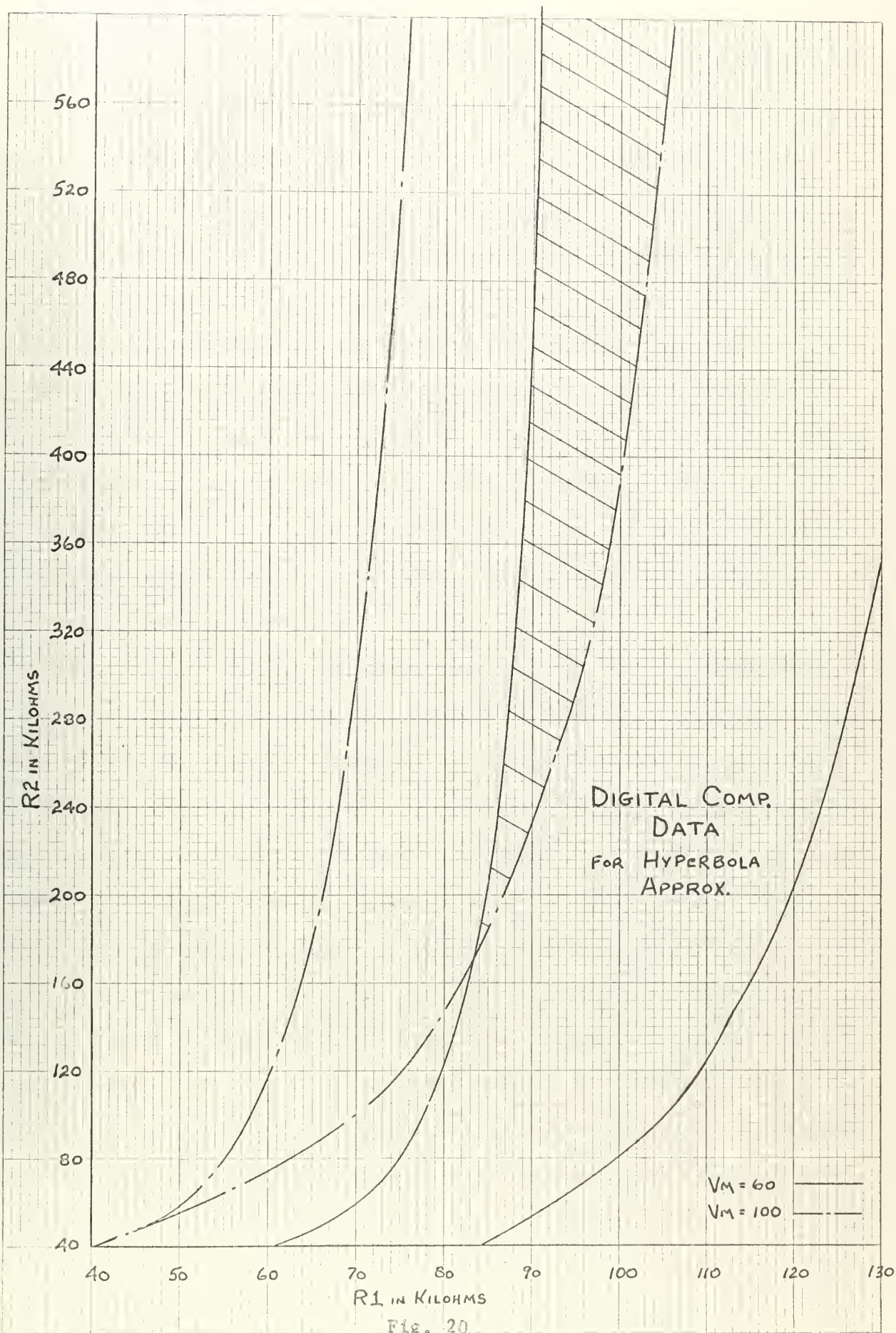
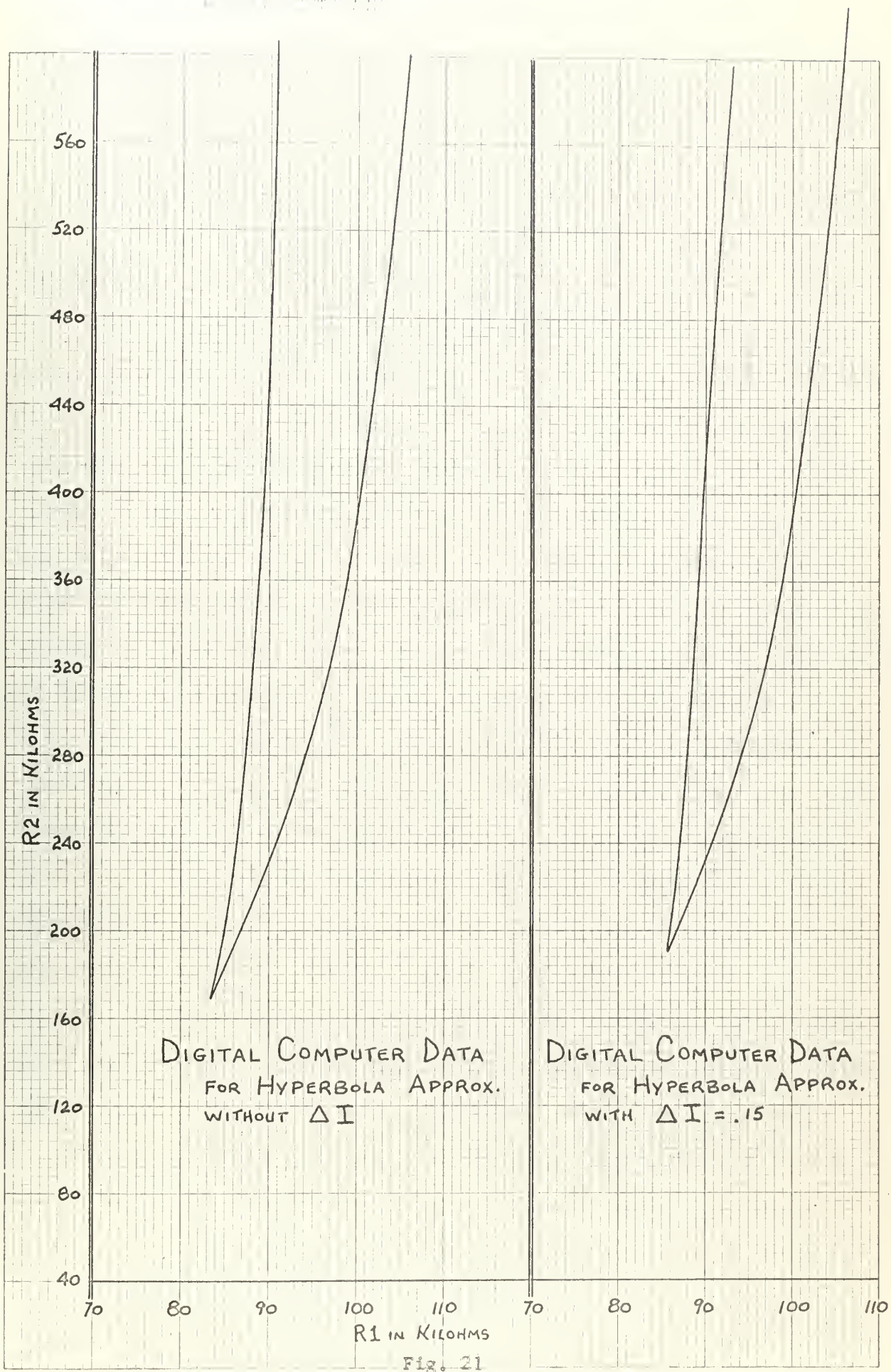

Fig. 20

has its smallest value when R1 takes on its largest possible value and still remains inside the plotted area. For the same value of R1, the deviation due to temperature has its smallest value when R2 takes on its smallest possible value inside the plotted area. The same conclusions are true for other similar plots. To see the overall effect on the main program for the hyperbola and "second order" approximations, the difference in neon currents due to temperature variations (called delta in the computer program) was restricted to first .015 and then .010 milliamperes. The resultant area plots for the hyperbola without delta and with delta equal to .015 are shown in figure 21. With the program rerun using delta of .010, a resultant area did not exist. A comparison of the final area curves with and without delta reveals that the left edge of the resultant areas which employed the delta restriction are moved further to the right, whereas the right edge is unaltered.

The resultant area curves, since they are in effect the common area of the individual areas, cannot be mapped for the variation in neon currents. Any point in the resultant area meets all of the specifications that were required and is a good design set. To determine the best part of the final design area we will resort to inductive reasoning. In inductive reasoning, a set of individual cases is studied by the experimental method, and from the observations made, a general principle is formed. The principle formed by inductive reasoning is reliable only when all possible instances have been examined. In the individual areas, the mapping procedure resulted in the conclusions that the best design set would be the smallest value of R2 and the largest value of R1 that fell within the plotted area. Applying inductive reasoning to this information, the best set in the resultant area curve is also the smallest value of R2 and the largest value of R1. Consideration also has to be given to the variation in the design parameters R1 and



R1 IN KILOHMS

Fig. 21

R2. If R_1 and R_2 were invariant then the apex of the area would be the best design set. R_1 and R_2 may have tolerances themselves of from 5 to 10 per cent of their nominal value, hence some point that could be the center of a circle whose radius is the resistance tolerance and where the circle fell entirely within the resultant area at the lowest part, would be the best design set.

The resultant area curves of the hyperbola and second order approximations are almost identical in position and shape. Minor variations in shape can be attributed to the plotting of the individual computer incremental output data. As an example of this problem in plotting consider a design increment change of 2 kohms in R_1 where the value of the design parameter resulted in a successful circuit prior to the increment change, but failed after the increment change. Theoretically then the plotted curve could pass through the first point and it also could pass through any point to the right of this original point up to but not including the value of the original point plus the increment. Here then is another factor in considering the number of design sets to be investigated versus computer time. This factor should not carry too much weight since in the final design, the designer will pick a point somewhat removed from the actual boundary curve itself. The resultant areas as obtained by the two approximations should be the same for large values of R_2 . The difference is noticeable where R_2 is 280 kohms or less. In this range of R_2 compensation is more effective and the second order area is a more accurate representation. However, in the final analysis the differences between the two approximations prove to be very minor.

Returning to figure 17 where the voltage is fixed at 60 volts and Z is 2.5, it appears that $R_2 \rightarrow \infty$ at $R_1 = 83$ kilohms. The digital computer printout data when plotted reveals that the lower curve is in effect the locus of combinations of R_1 and R_2 which result in neon currents of 1.5

milliamperes and the upper curve is a similar locus for currents of 2.5 milliamperes. These curves are actually only approximate loci of these constant current values since the points which were used to construct the curves were obtained by using incremental values of design parameters.

The system equation which was of the form $AI^2 + BI + C = 0$ was solved explicitly on the digital computer for I_2 as a function of five parameters. If the system equation is rewritten so as to express R_2 as a function of the remaining parameters, the result using the hyperbola approximation would be:

$$R_2 = \frac{2.17 \times 10^{-11} (10^{-10} R_1^2 - 1.46 \times 10^{-10} R_1 + 1.2 \times 10^{-10})}{2.17 \times 10^{-11} - 1.1 \times 10^{-11} R_1 + 1.2 \times 10^{-11} R_1^2}$$

$$R_2 = 2.17 \times 10^{-11}$$

Using a neon current of 2.5 milliamperes, a voltage of 60 volts, a Z of 2.5 and a mean temperature of 40°C , the value of R_1 to make the denominator of the equation zero is 85 kohms. Using this equation similar results could be predicted for other maintaining voltages, namely that in the plot of design parameter R_2 versus design parameter R_1 there are values of R_1 where R_2 goes to infinity. Since the resultant area is constructed from the individual area plots we cannot expect to have a closed resultant design area plot.

The insight gained from the interpretation of the digital computer data for the circuit synthesis problem revealed that the constructed boundary lines are in essence loci of constant neon currents, namely the extremes of the specified neon current limits of 1.5 and 2.5 milliamperes. This suggests an alternate technique for solving the circuit synthesis problem. This alternate technique lends itself to solution using an analogue computer.

7. Description of Electronic Analogue Computer Technique

The technique to be employed with the analogue computer parallels the development of the digital computer technique to a certain extent. Known and design parameters are as defined previously. The resultant circuit equation is manipulated to express one design parameter explicitly as a function of the remaining design and known parameters. Increments of the known parameters and end points of the known parameters are determined as in the digital computer technique. The explicit circuit equation is then converted into an electronic analogue. The electronic analogue computer is set up so that its equations have the same mathematical form as the equation for the physical system under consideration. In the computer, voltages are used to represent various physical quantities such as velocity, position, etc. Scaling factors are used to convert the physical quantities into appropriate numerical values in the computer. The mathematical functions of addition, multiplication, etc., are performed by electronic operational amplifiers using scaled voltages as inputs.

Large variations in known parameters can be readily undertaken provided the range in variation is considered during the scaling process. Incremental changes in the known parameters are accomplished by merely varying the coefficient potentiometers that are associated with the parameter under investigation. Radical changes in the known parameters may have to be handled by varying the components of the operational amplifiers, or by the insertion of one or more additional amplifiers.

A design parameter that is implicit in the circuit equation is varied by the application of a ramp voltage input causing the explicit parameter output voltage to be the continuous solution for a fixed set of known parameters. Utilization of an X-Y plotter will present a graphical representation of a design parameter voltage as a function of another design parameter voltage.

Each time that a known parameter is varied a new curve will be traced out on the X-Y plotter. The number of known parameters that can be varied on any one sheet of the X-Y plotter becomes evident when a loss of identity in the plotted curves results. This procedure is repeated until graphical plots are obtained for every increment of each of the known parameters. These plots are antiscaled on the X-Y plotter so that the graphical plots which are obtained in this manner are design parameters as used in the original physical system prior to the analogue conversion. Each plot has only investigated one or more variations in known parameters. If all of the plots are overlayed, the area which is common to the acceptable area of all the graphs is the final design area desired. Any point in this final common area meets all of the required specifications.

Rearrangement of the basic circuit equation employing the hyperbola approximation for the photoconductors resulted in the form:

$$R_2 = \frac{2BZ I (R_1 + 10^3 BZ) - 2IZ(V - V) + VI(R_1 + 10^3 BZ)}{I(3Z - V) - I^2(R_1 + 10^3 BZ)}$$

where $B = 2.11 \times 10^{-11} T$

The neon current I is now an end point type of known parameter rather than the output quantity as in the digital computer technique. The two neon current values of interest are 1.5 and 2.5 milliamperes. Physical quantities such as ohms, amperes, and maintaining voltage in the circuit equation are transformed into voltages for use in the electronic analogue by appropriate scaling. Known parameters of temperature and Z are divided into increments as before. A change in the value of any known parameter is accomplished by altering the individual potentiometers that are associated with the parameter under investigation. Since the range of all the known parameters vary by less than a factor of ten, it is possible to utilize one analogue computer circuit and account for all of the variations by suitable scaling of the physical parameters. A schematic of the analogue computer

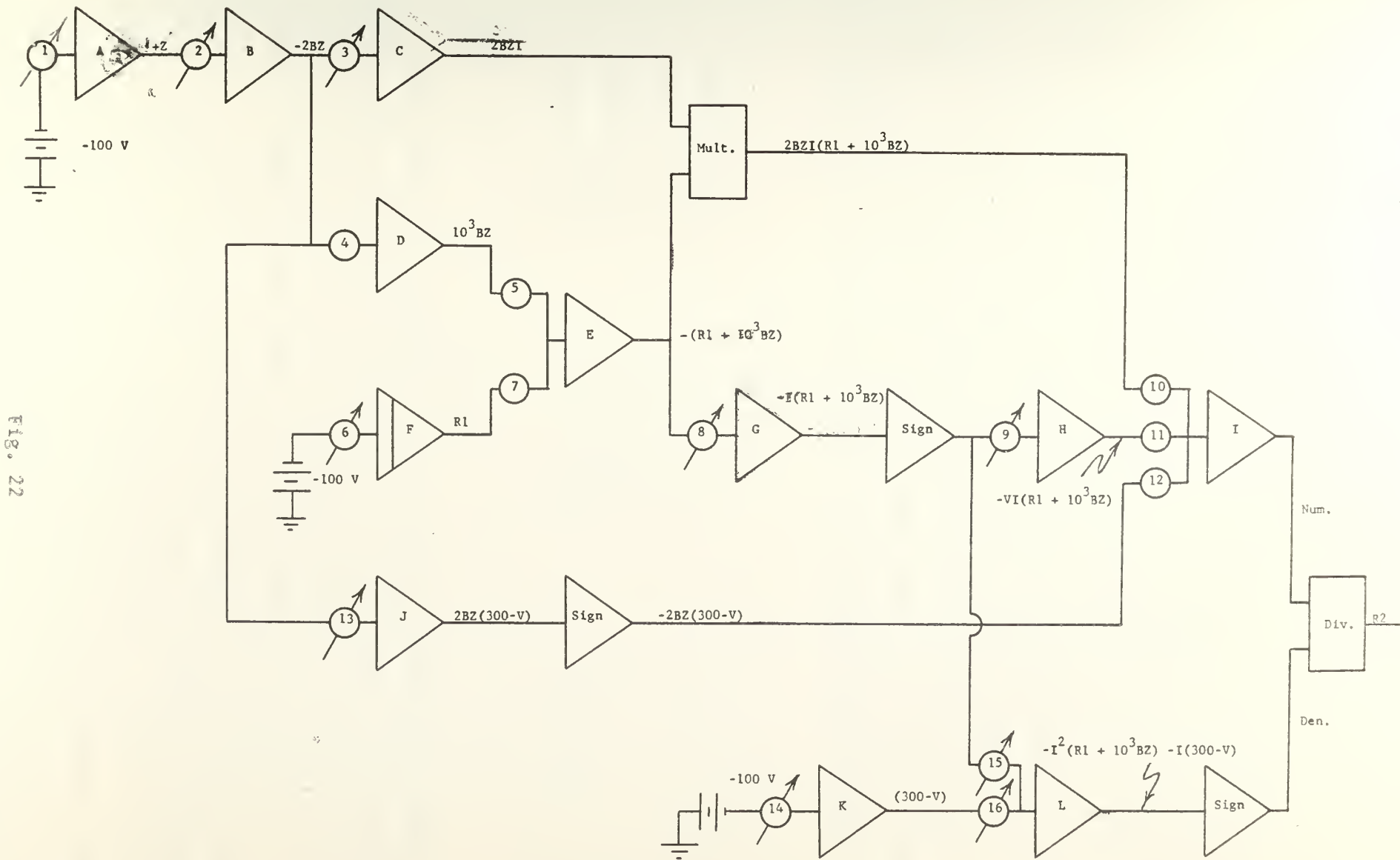

amplifier sequence is illustrated in figure 22.

A step voltage applied to integrating amplifier F produces a ramp voltage which corresponds to design parameter R1. This continuous variation of design parameter R1, with a fixed set of temperature, Z, maintaining voltage and neon current will produce a continuous solution for the explicit design parameter R2. Potentiometers a4, a5, a7, a10, a11 and a12 are held constant at one value throughout the problem. These constant potentiometer settings are determined by scaling physical quantities which are invariant. The setting of the variable potentiometers at any one instance depend upon the known parameter that is being investigated. Table #2 lists the dependence of each known parameter on its associated potentiometers.

Table #2

| | | |
|----------------|----------------|------------------|
| Variation in I | Potentiometers | a3, a8, a15, a16 |
| Variation in T | Potentiometer | a2 |
| Variation in Z | Potentiometer | a1 |
| Variation in V | Potentiometers | a9, a13, a14 |

Figure 23

Each of the known parameters one at a time is systematically varied by changing their associated potentiometers. The two voltages in the electronic analogue which represent design parameters R1 and R2 are automatically plotted by inserting these continually varying voltages as inputs to an X-Y plotter during any one solution which corresponds to a particular known set of parameters. The output of the X-Y plotter is a graphical representation of design parameter R2 versus design parameter R1. A typical output curve for Z (photoconductor resistance magnitude multiplying factor) corresponding to .4 appears as in figure 24. This curve includes the effect of temperature, maintaining voltage and neon currents. Solid lines represent

maintaining voltages of 60 volts and dashed lines represent maintaining voltages of 100 volts. The three temperatures investigated are 25°C, 40°C, and 55°C which are recorded from right to left in groups of three lines. For each maintaining voltage, the lower group corresponds to 1.5 milliamperes and the remaining group corresponds to 2.5 milliamperes. Similar curves for other values of Z appear in figures 25, 26 and 27.

As was mentioned previously in section four, the known parameters, temperature (T), and photoconductor resistance magnitude multiplying factor (Z), were established as incremental types of parameters since $\frac{\partial I}{\partial T}$ and $\frac{\partial I}{\partial Z}$ could not be proven to be of constant sign for the entire range of variation. Examination of figures 24 through 27 discloses that for the maintaining voltage equal to 60 volts, the three temperature curves of the lower group (neon current equal to 1.5 milliamperes) cross over each other. This cross over is indicative of a point of inflection in $\frac{\partial I}{\partial T}$ or stated in other terms the value of $\frac{\partial I}{\partial T}$ changed sign at the point of temperature cross over. By overlaying figures 24 and 25 a similar effect would be noticed for Z, namely that for one value of temperature, maintaining voltage and neon current the overlaid curves corresponding to two different values of Z would cross over. This cross over indicates where a point of inflection exists for $\frac{\partial I}{\partial Z}$. An overlapping technique as applied to the digital computer areas is used in finding the area common to the individual areas. The resultant design area is figure 28. Since all of the points of inflection for temperature and photoconductor resistance magnitude multiplying factor lie outside the resultant design area, these quantities are in effect end point type of known parameters if the term as used here applies only to the resultant design area.

The design area as obtained from the analogue computer in conjunction with the X-Y plotter meets the requirements of circuit performance with any set of known parameters. The lines forming the boundaries of the area are

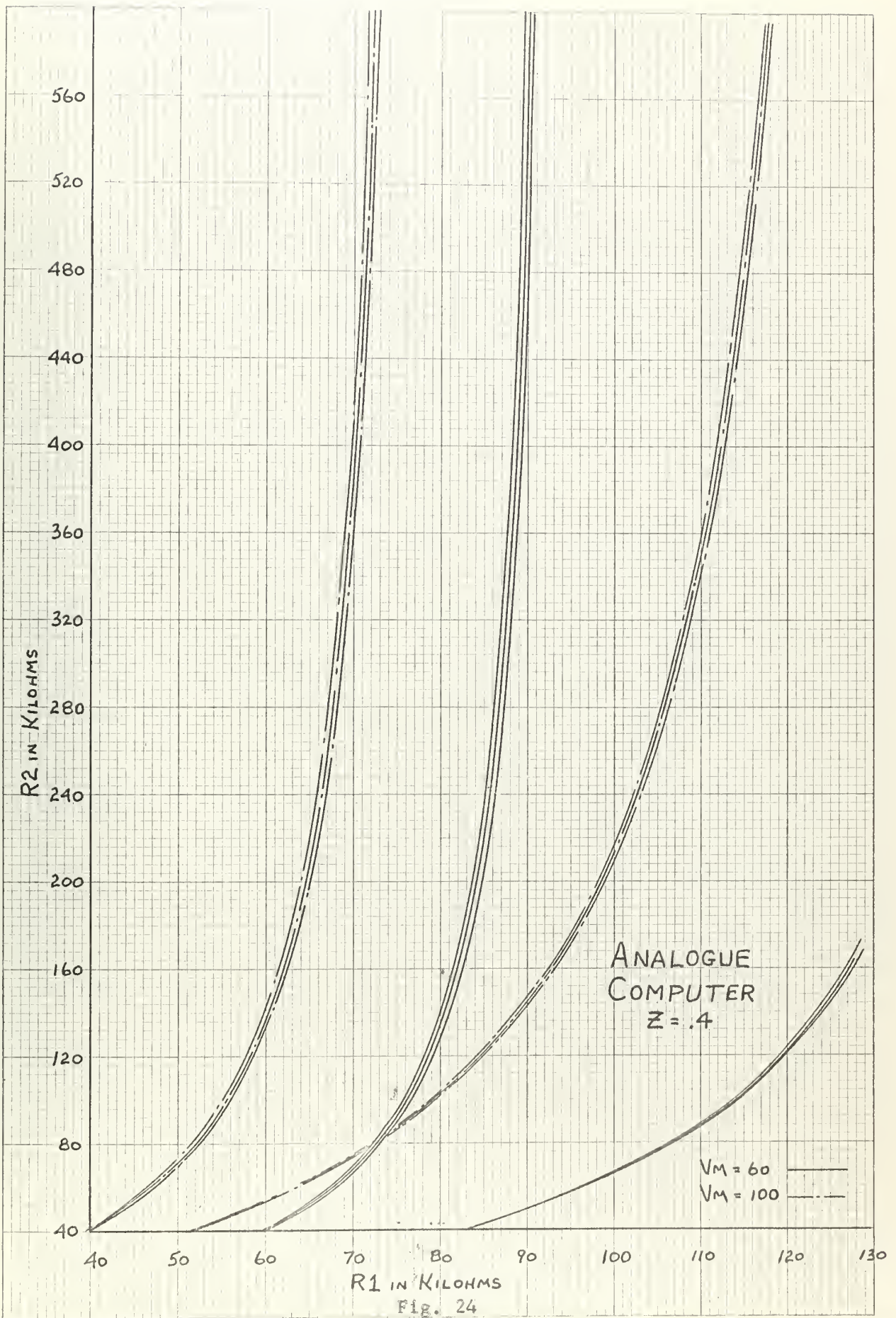

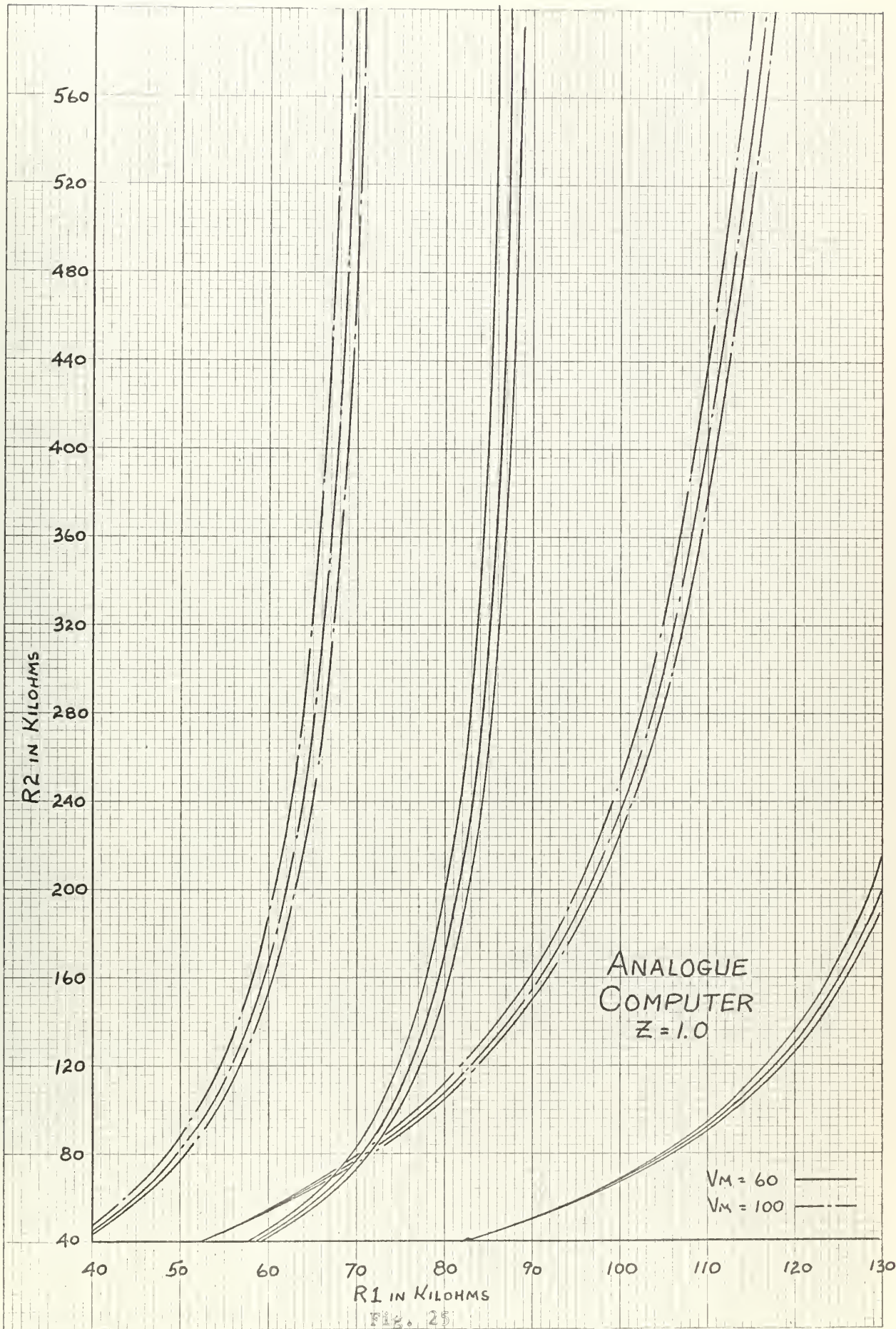

Fig. 25

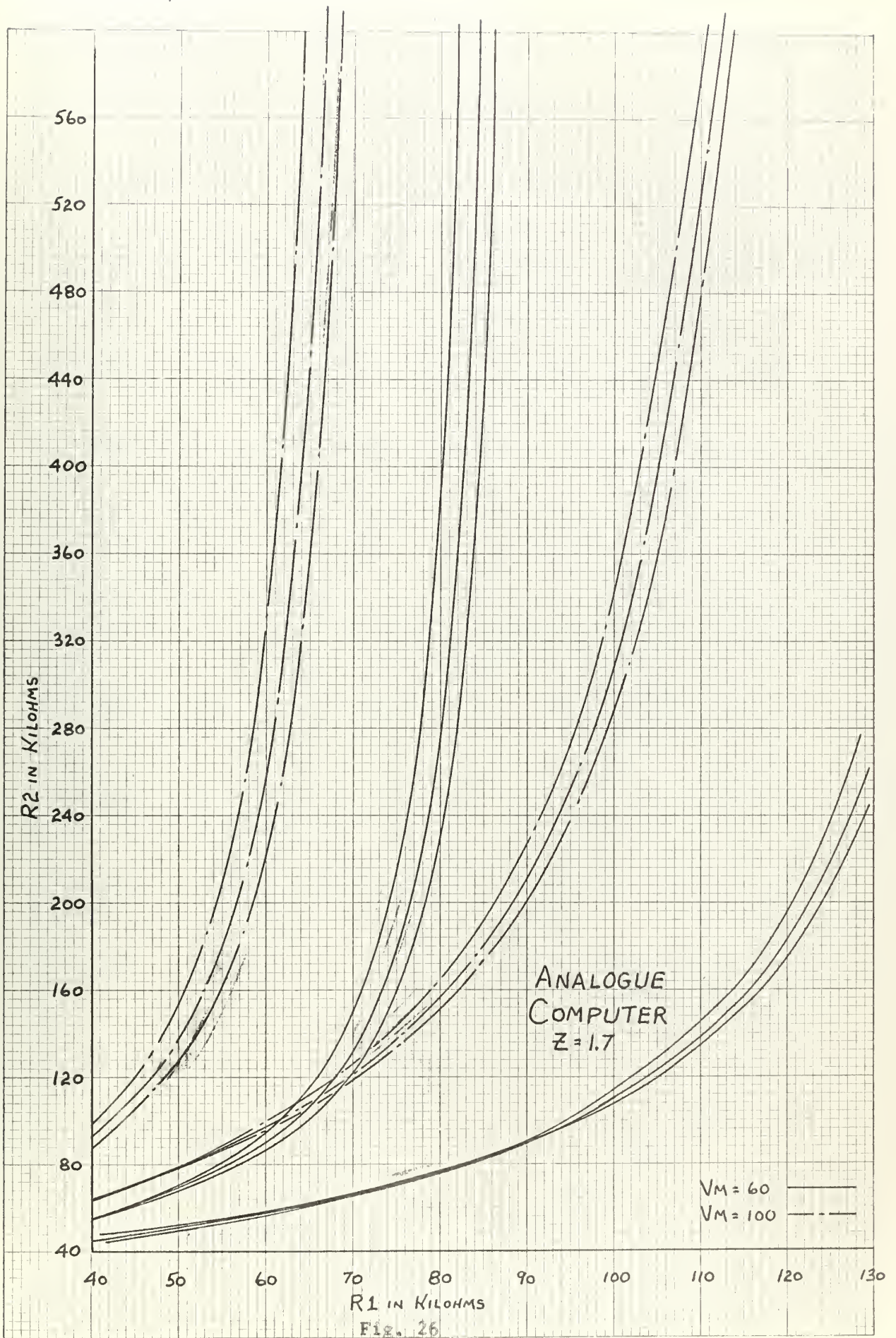
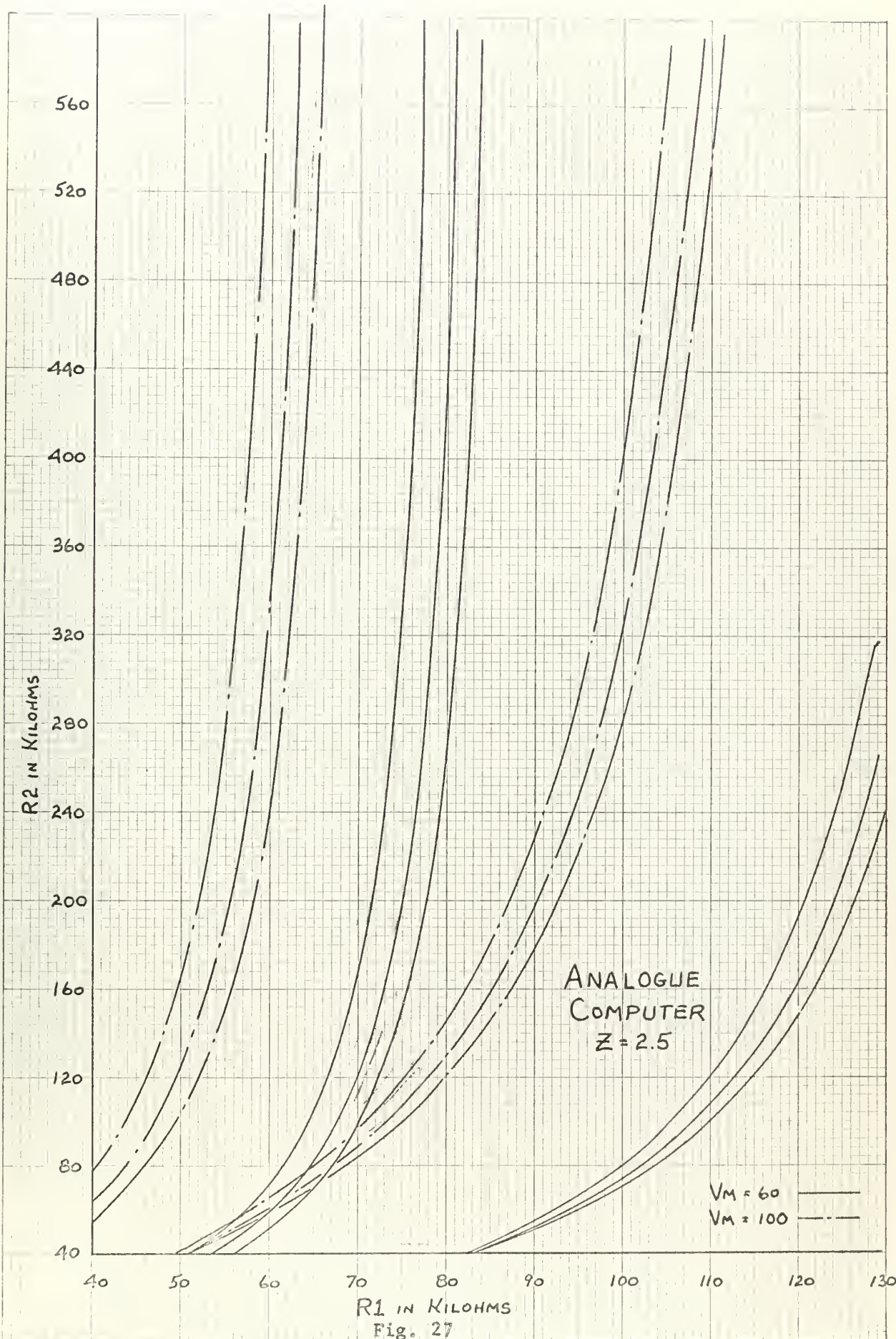
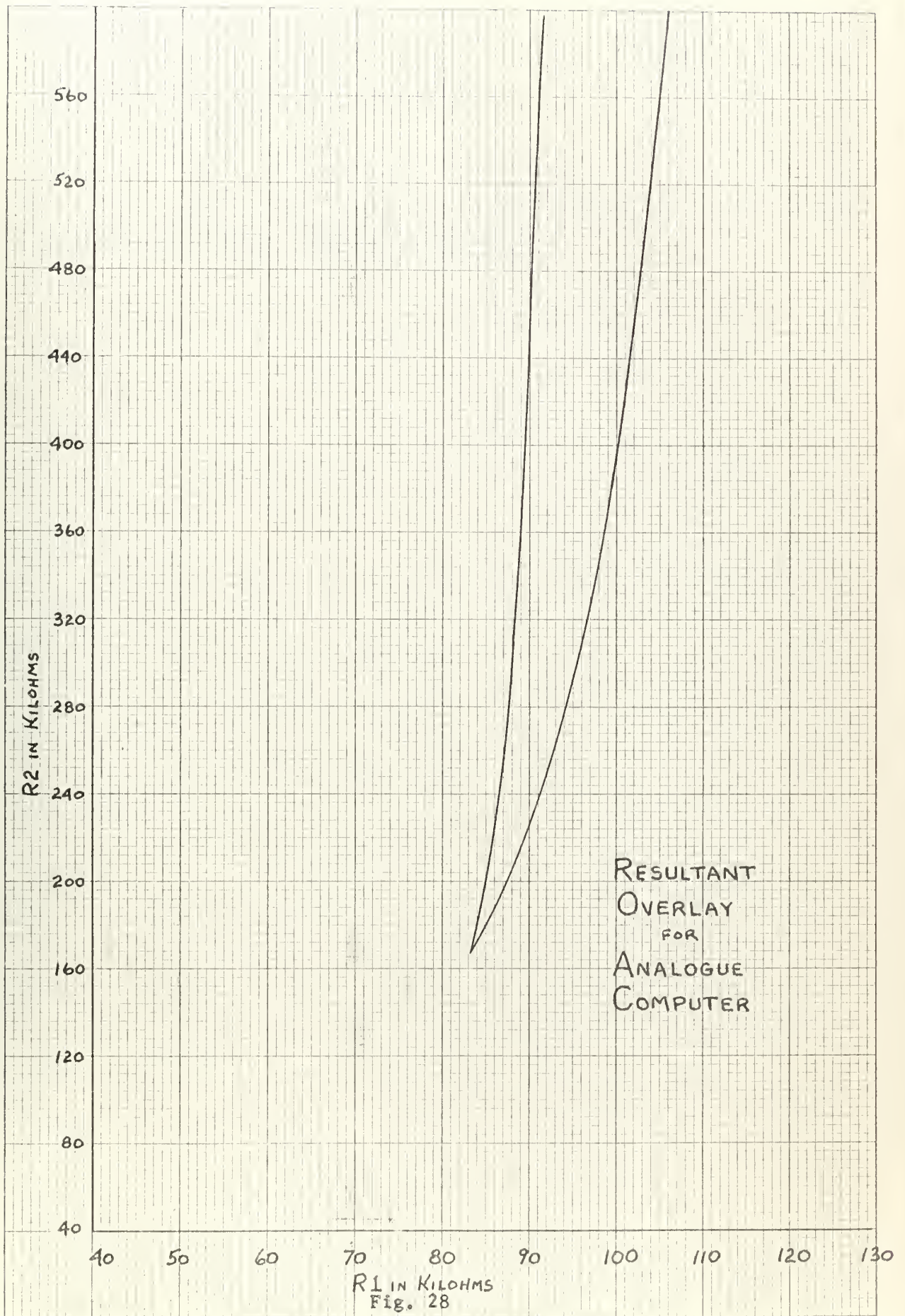

Fig. 26



R_1 IN KILOHMS
Fig. 27



exact since the solution is continuous rather than increments as in the digital computer plot. A best design parameter combination cannot be determined from this design area as was obtained from the digital computer data, since there is no additional information available about the resultant design area upon which the designer can base a choice. This perhaps is its sole weakness as compared to the digital computer technique.

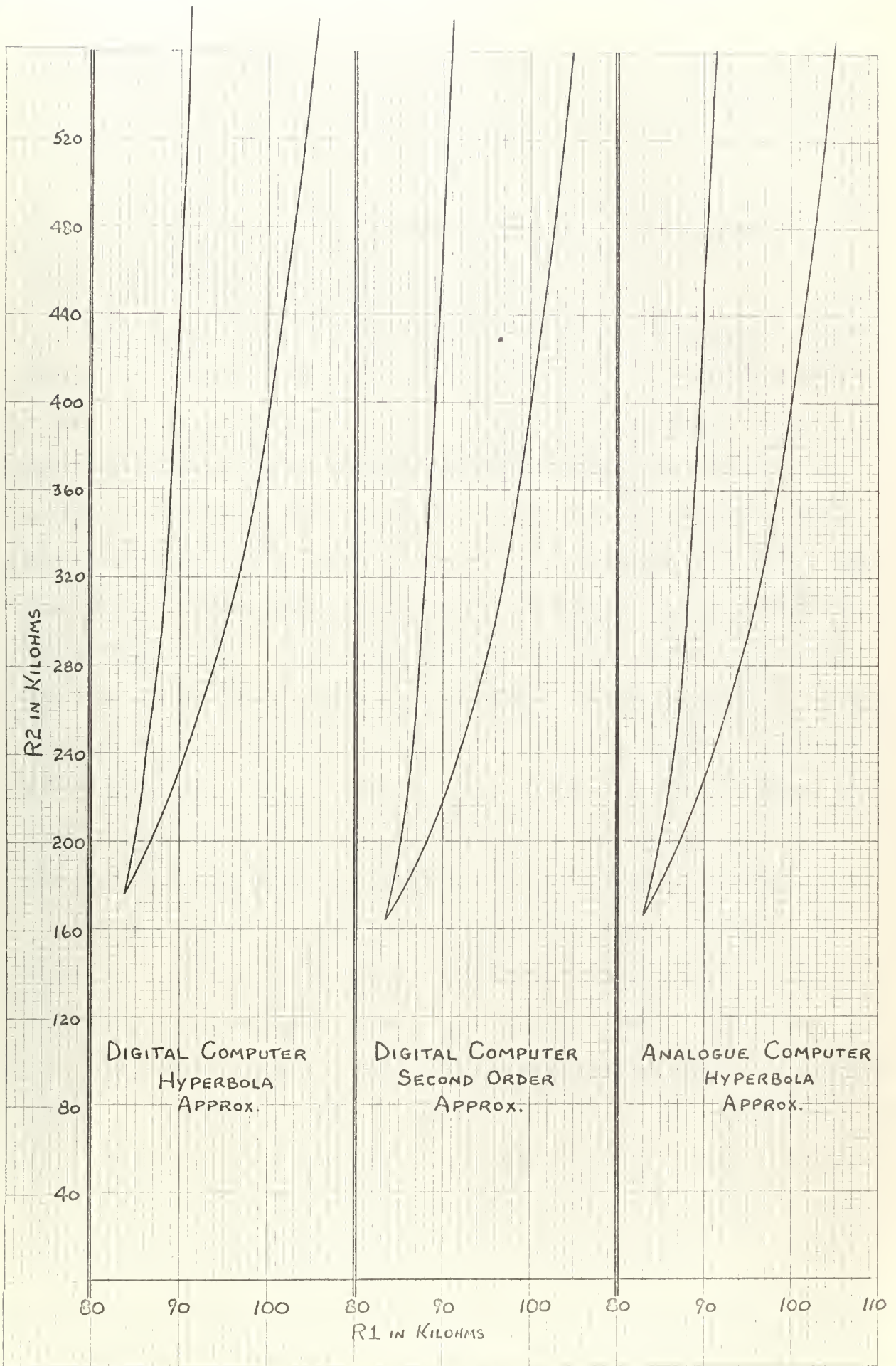

8. Conclusions.

The problem of how to design a circuit to meet specifications while using parameters which have wide ranges of variation can be solved using either of the computer techniques described. The designer has merely to select design parameters from a final area with the assurance that the circuit will meet the output specifications.

Both the digital and the analogue computer techniques provide adequate design data. Each method has advantages; there is little difference in the amount of time involved from start of problem until solution. This time naturally depends upon the designer's experience and familiarity with a particular computer. The accuracy is comparable in either method; while the digital computer is more accurate for any individual calculation, the analogue has the advantage of providing a continuous solution rather than an incremental one. The analogue computer, when used with an X-Y plotter provides the area curves directly without the plotting necessary to reduce the digital data. However, the digital computer can be easily programmed to provide additional data useful in analysis of a specific, designed circuit. There were no logic circuits employed in the analogue solution, therefore the significant test for ΔI was not made in this solution.

For the specific circuit used to demonstrate these techniques, it should be noted that the scheme for temperature compensation did achieve the desired compensation as reference to figures 17 and 18 will show. The additional labor involved in employing the more complex second order approximation is not warranted since there is no significant difference between the final design areas obtained with the two approximations. Figure 29 compares the results obtained with the two approximations using the digital computer and the hyperbolic approximation using the analogue computer.

Additional investigation should be conducted to extend the study to include an analysis of the circuit's transient behavior. A method of including logic circuitry in the analogue circuit would permit the additional test for delta I to be conducted. A circuit involving the selection of three design parameters presents an interesting problem. In this case, instead of acceptable area graphs, the result would be a three dimensional acceptable volume plot of the design parameters.

APPENDIX I

MATHEMATICAL DERIVATION LEADING TO SECOND ORDER EXPRESSION FOR
PHOTOCONDUCTOR RESISTANCE-NEON CURRENT RELATIONSHIP

To obtain a mathematical expression which approximates the photoconductor resistance variation with neon current shown in curve B, the relationship is assumed to be of the form:

$$AR_p I + BI^2 + CR_p^2 + D = 0$$

The following points, selected from the curve were used to determine the unknown coefficients A, B, C and D.

| | | | | |
|-----------|------|------|------|------|
| I in ma. | 1.50 | 1.80 | 2.20 | 2.50 |
| R in Kohm | 6.71 | 5.10 | 3.88 | 3.37 |

$$A(6.71)(1.5) + B(1.5 \times 10^{-3}) + C(6.71 \times 10^3) + D = 0 \quad (1)$$

$$A(5.1)(1.8) + B(1.8 \times 10^{-3}) + C(5.1 \times 10^3) + D = 0 \quad (2)$$

$$A(2.2)(3.88) + B(2.2 \times 10^{-3}) + C(3.88 \times 10^3) + D = 0 \quad (3)$$

$$A(2.5)(3.37) + B(2.5 \times 10^{-3}) + C(3.37 \times 10^3) + D = 0 \quad (4)$$

$$.885 A - .3 \times 10^{-3} B + 1.61 \times 10^3 C = 0 \quad (1) - (2)$$

$$.111 A - .3 \times 10^{-3} B + .51 \times 10^3 C = 0 \quad (3) - (4)$$

Subtracting,

$$2.2 \times 10^{-3} B - 8.22 \times 10^{-3} C + D = 0$$

$$A = \frac{10 \times 10^{-3}}{710} \times 10 = (41.7 \times 10^{-5})$$

$$= 12.1 \times 10^{-4} + 2.2 \times 10^{-3} B + 8.22 \times 10^{-3} C + D = 0 \quad (3a)$$

$$= 11.92 \times 10^{-3} C + 2.5 \times 10^{-3} B + 3.11 \times 10^{-3} C + D = 0 \quad (4a)$$

$$2.2 \times 10^{-3} B - 8.22 \times 10^{-3} C + D = 0$$

$$2.5 \times 10^{-3} B - 8.22 \times 10^{-3} C + D = 0$$

Subtracting,

$$3 \times 10^{-3} B - 3.3 \times 10^{-3} C = 0$$

$$B = 1.1 \times 10^{-6} C$$

Substituting in (4a) and simplifying,

$$2.5 \times 10^{-3} (1.1 \times 10^{-6} C) - 8.22 \times 10^{-3} C + D = 0$$

$$2.75 \times 10^{-9} C - 8.22 \times 10^{-3} C + D = 0$$

$$D = 8.22 \times 10^{-3} C$$

for $C = 1$

$$= 1.419 \times 10^{-4} R_p I + 11 \times 10^{-6} I + R_p + 5.1 \times 10^{-3} I$$

$$R_p = \frac{11 \times 10^{-6} I + 5.1 \times 10^{-3} I}{1.419 \times 10^{-4} I - 1}$$

$$R_p = \left(\frac{11 \times 10^{-6} I + 5.1 \times 10^{-3} I}{1.419 \times 10^{-4} I - 1} \right) \times 10^3$$

To incorporate the effect of temperature, rewrite in the following form:

$$R_T = A \frac{R_{20} [1 + \alpha (T - 20)]}{1 + \alpha (T - 20)}$$

$$A = e^{15 \times (70 - 20)}$$

The final form of the second-order approximation is then

$$P_2 = \frac{1}{2} \left(\frac{b \sin^2 \theta}{1 + \cos^2 \theta} \right) e^{-\cos^2 \theta}$$

BIBLIOGRAPHY

1. J. W. Backus, The FORTRAN Automatic Coding System, limited publication.
2. W. Orchard-Hays, The Evolution of Programming Systems, Proc. IRE, 49, pp. 283-295, January 1961.
3. D. D. McCracken, A Guide to FORTRAN Programming, John Wiley & Sons, July 1961.
4. H. S. Scheffler and F. P. Terry, Description and Comparison of Five Computer Methods of Circuit Analysis, Autometrics, Downey, California, August 1961.
5. H. S. Scheffler, A. P. Lechler, and L. H. Stember, Jr., Circuit Analysis Techniques Utilizing Digital Computers, Battelle Memorial Institute, Columbus, Ohio, January 1961.
6. G. A. Korn and T. M. Korn, Electronic Analog Computers, McGraw-Hill, 1952.
7. C. L. Johnson, Analog Computer Techniques, McGraw-Hill, 1956.
8. R. C. H. Wheeler, Basic Theory of the Electronic Analog Computer, Donner Scientific Company, Berkeley, California, July 1955.

thesB727

Computer techniques for synthesis of cir



3 2768 002 07339 7

DUDLEY KNOX LIBRARY