

UNCLASSIFIED

AD NUMBER

AD480924

LIMITATION CHANGES

TO:

Approved for public release; distribution is unlimited.

FROM:

Distribution authorized to U.S. Gov't. agencies and their contractors;
Administrative/Operational Use; 1962. Other requests shall be referred to U.S. Naval Postgraduate School, Monterey, CA 93943.

AUTHORITY

USNPS ltr, 23 Sep 1971

THIS PAGE IS UNCLASSIFIED

NPS ARCHIVE
1962
CASE, R.

INVESTIGATION AND APPLICATION OF
REVERBERATION MEASUREMENTS IN WATER

RICHARD W. CASE
and
EUGENE W. VAHLKAMP

AD-480924

INVESTIGATION AND APPLICATION OF
REVERBERATION MEASUREMENTS IN WATER

[REDACTED]

by

Richard W. Case

Lieutenant Commander, United States Navy

and

Eugene W. Vahlkamp

Lieutenant, United States Navy

[REDACTED]

Submitted in partial fulfillment of
the requirements for the degree of

MASTER OF SCIENCE
IN
ENGINEERING ELECTRONICS

United States Naval Postgraduate School
Monterey, California

1 9 6 2

[REDACTED]

MPS Archive
1962
Case, R.

~~C 2746~~
K.1

[REDACTED]

[REDACTED]

[REDACTED]

INVESTIGATION AND APPLICATION OF
REVERBERATION MEASUREMENTS IN WATER

* * * * *

Richard W. Case

and

Eugene W. Vahlkamp

1962

UNITED STATES NAVAL POSTGRADUATE SCHOOL

Degree: Master of Science in
Engineering Electronics

Classification:

Thesis: Unclassified

Abstract: Unclassified

Title of Thesis:

Unclassified

Contains no proprietary
information

INVESTIGATION AND APPLICATION OF
REVERBERATION MEASUREMENTS IN WATER

* * * * *

Richard W. Case
and
Eugene W. Vahlkamp

INVESTIGATION AND APPLICATION OF
REVERBERATION MEASUREMENTS IN WATER

by

Richard W. Case

and

Eugene W. Vahlkamp

This work is accepted as fulfilling
the thesis requirements for the degree of

MASTER OF SCIENCE

IN

ENGINEERING ELECTRONICS

from the

United States Naval Postgraduate School

ABSTRACT

A method of determining sound absorption coefficients of underwater sound absorbing materials is presented applying reverberation techniques similar to those employed in air.

Reverberation measurements at frequencies of 10-100 KC were made in a small tank. Decay rates from 55-25,000 db/sec were observed under various conditions of tank linings. These decay rates corroborate C. F. Eyring's model of the phenomena of reverberation as opposed to W. C. Sabine's in that they lead to values of Sabine's coefficient greater than one (up to 2.56) when the tank was fully lined with a highly absorbent material. Sabine defined a coefficient of one for a perfect absorber, such as an open window.

A technique was developed capable of measuring decay rates up to 200,000 db/sec over a limited range of 50 db. Diffusion was obtained by use of a filtered noise source and a suspended air filled balloon, while problems involving methods of averaging coefficients were avoided by treating all surfaces completely with the same absorbent material.

Measurement of power through decay rates as proposed by R. W. Young was accomplished and results were compared with those obtained using pulse technique, no consistent agreement could be found.

The writers wish to express their appreciation for the assistance and encouragement given them in this investigation by Professor L. E. Kinsler of the U. S. Naval Postgraduate School. This investigation was carried out under the sponsorship of the Office of Naval Research. The work was conducted entirely at the U. S. Naval Postgraduate School, Monterey, California.

TABLE OF CONTENTS

Section	Title	Page
1.	Introduction	1
2.	Background	3
3.	Description of Tank and Lining Material	9
4.	Description of Equipment	11
5.	Measurements	12
6.	Results	14
7.	Conclusions	17
8.	Bibliography	20
Appendix		
I	Hydrophone Calibration	22
II	Absorption Coefficient by Pulse Technique	25

LIST OF ILLUSTRATIONS

Figure		Page
1.	Typical Views of Cone Lattice Structured Material	26
2.	Block Diagram of Equipment Used for Reverberation Measurements	27
3.	Photographs of Decay Rates in an Unlined Tank	28
4.	Photographs of Decay Rates with Flat Lining in the Tank (10 KC and 20 KC)	29
5.	Photographs of Decay Rates with Flat Lining in the Tank (50 KC and 100 KC)	30
6.	Photographs of Decay Rates with Cone Lattice Structured Lining in the Tank (10 KC and 20 KC)	31
7.	Photographs of Decay Rates with Cone Lattice Structured Lining in the Tank (50 KC and 100 KC)	32
8.	Geometry of Destructive Interference Patterns in Pulse Technique Measurements	33
9.	Geometry of Integration for Power Measurement by Pulse Technique	34
10.	Directivity Pattern of LC 32 Hydrophone at 10 KC	35
11.	Directivity Pattern of LC 32 Hydrophone at 20 KC	36
12.	Directivity Pattern of LC 32 Hydrophone at 50 KC	37
13.	Directivity Pattern of LC 32 Hydrophone at 100 KC	38
14.	Block Diagram of Equipment Used for Pulse Technique Measurements	39

SYMBOLS

a	Sabine absorption coefficient of a material
\bar{a}	Average Sabine coefficient of an enclosure
α	Random energy absorption coefficient of a material
$\bar{\alpha}$	Average energy absorption coefficient of an enclosure
c	Speed of sound
D	Decay rate in decibels per second
db	Decibels
$\langle E \rangle$	Average energy density
e	2.71828...
\ln	Natural logarithm (to base e)
m	Meter
n	Newton
p	Sound pressure (rms)
ρ	Density
R	Reflectivity, the ratio of energy reflected to that incident
S	Surface area
t	Time
T	Reverberation time
V	Volume of enclosure
W	Power output of a transducer

1. Introduction.

The determination of absorption coefficients of acoustical materials has attracted considerable interest and effort over the years. In spite of the wealth of talent applied to this problem, both in theory and practice, many conflicts remain unresolved.

The sound absorption coefficients as published in Acoustical Materials Association Bulletin¹ are based upon W. C. Sabine's theory^{2,3}. Many materials listed therein have a Sabine coefficient of 0.99 but none are shown greater than unity, a value which C. F. Eyring⁴ indicates corresponds to a true absorption coefficient of only 0.63.

Recently R. W. Young⁵ published a review article in this field which proposed modifications to present engineering practice. The paper also presented a method for determining sound power output of a transducer by measurement of a decay rate, a steady state sound pressure, and an average

¹Sound Absorption Coefficients of Architectural Acoustical Materials, Acoustical Materials Association, Bulletin XXI, A.T.A. No. 39-b, 1961.

²P. E. Sabine, The Measurement of Sound Absorption Coefficients, J.F.I., 207, pp. 342-344, Mar., 1929.

³Tentative Method of Test for Sound Absorption of Acoustical Materials in Reverberation Rooms, ASTM Designation: C 423 - 60 T, 1960 Supplement to Book of ASTM Standards, Part 5, American Society for Testing Materials, 1960.

⁴C. F. Eyring, Reverberation Time in "Dead" Rooms, J.A.S.A., 1, pp. 217-235, Jan., 1930.

⁵R. W. Young, Sabine Reverberation Equation and Sound Power Calculations, J.A.S.A., 31, pp. 912-921, July, 1959.

absorption coefficient in the enclosure under consideration.

The purpose of this investigation is (a) to test the correctness of Eyring's theory by measuring Sabine absorption coefficients for a highly absorbent material, (b) to adapt reverberation techniques for determination of sound absorption coefficients to water, and (c) to test the usefulness of Young's theory on power measurements.

2. Background.

W. C. Sabine recognized that the validity of his empirical reverberation equation,

$$T = \frac{KV}{aS} \quad (1)$$

was dependent upon: (1) the duration of audibility being nearly the same everywhere in an auditorium, (2) the duration of audibility being nearly independent of the position of the source, and (3) the efficiency of an absorbent in reducing the duration of audibility being nearly independent of its position.⁶

P. M. Morse and R. H. Bolt⁷ give a very good summary of the classical kinetic theory derivation of Sabine's empirical equation. It is based upon three assumptions: (1) a diffuse sound field is present at all times, (2) there is an equal probability of propagation of sound in all directions, and (3) the absorption of sound at the boundaries is continuous. These three conditions give rise to a differential equation with regard to the conservation of energy,

$$\left[\begin{array}{l} \text{Rate of increase} \\ \text{of energy in room} \end{array} \right] = \left[\begin{array}{l} \text{Rate of emission of} \\ \text{energy from source} \end{array} \right] - \left[\begin{array}{l} \text{Rate of absorption} \\ \text{of energy of walls.} \end{array} \right] \quad (2)$$

Let $\langle E \rangle$ be the energy density, V the volume of the enclosure, and W the power output of the source, then

$$V \frac{d\langle E \rangle}{dt} = \text{rate of increase of energy.}$$

The rate at which energy strikes a unit area is $\langle E \rangle \cdot c/4$ as obtained by

⁶P. M. Morse and R. H. Bolt, Sound Waves in Rooms, Rev. Mod. Phys., 16, p. 76, Jan., 1944.

⁷Ibid. pp. 76-78.

calculating the fraction of energy which falls on a unit area per second from a single direction, and then integrating this over all angles of incidence. The rate of absorption of the walls becomes

$$\frac{\langle E \rangle c}{4} \cdot \bar{a} S$$

with \bar{a} defined as the average absorption coefficient of the surface area S . (Sabine defined an open window as a perfect absorber with $a=1$.) The differential equation (2) becomes

$$V \frac{d\langle E \rangle}{dt} = W - \frac{\langle E \rangle c}{4} \cdot \bar{a} S \quad (3)$$

The solution for this equation when the source is turned off at $t=0$ is

$$\langle E \rangle = \frac{4W}{c\bar{a}S} \cdot e^{-\left(\frac{c\bar{a}S}{4V}\right)t} \quad (4)$$

The accepted usage in architectural acoustics in speaking of the energy density transient is reverberation time, that time required for the energy to fall to 10^{-6} of its initial value.

$$T = \frac{4V}{c\bar{a}S} \ln 10^{-6} = \frac{KV}{\bar{a}S} \quad (5)$$

which is the same equation as determined empirically by Sabine. It is simpler and more meaningful, however, to work with decay rates, and these will be used in this paper. Equation (5) then takes the form

$$D = \frac{60 \text{ db}}{T(\text{sec})} = \frac{1.086 c\bar{a}S}{V} \left(\frac{\text{db}}{\text{sec}} \right) \quad (6)$$

Eyring produced the first important modification to Sabine's equation by replacing the assumption of continuous absorption by discontinuous drops in the intensity after every reflection. His derivation was very succinctly

explained by R. F. Norris⁸. The resulting equation is

$$T = \frac{KV}{-S \ln(1-\bar{\alpha})} \quad (7)$$

or

$$D = \frac{-1.086 c S \ln(1-\bar{\alpha})}{V} \quad (\text{db/sec}) \quad (8)$$

The quantity $\ln(1-\bar{\alpha})$ leads correctly to $T=0$ for a perfectly absorbent enclosure ($\bar{\alpha}=1$), while Sabine's equation for $\bar{a}=1$ reduces only to

$$T = \frac{KV}{S}$$

Eyring's formula makes use of an average absorption coefficient

$$\bar{\alpha} = \frac{\sum \alpha_i S_i}{\sum S_i} \quad (9)$$

and works quite well when the α_i are nearly equal.

When the α_i vary widely, however, Eyring's equation becomes erroneous. G. Millington⁹ and W. J. Sette¹⁰ proposed a geometric averaging scheme to alleviate the problem of averaging dissimilar coefficients. Their equation is in the form

$$T = \frac{KV}{-\sum S_i \ln(1-\alpha_i)} \quad (10)$$

⁸R. F. Norris, A Derivation of the Reverberation Formula, Appendix II in Architectural Acoustics by V. O. Knudsen, John Wiley & Sons, Inc., 1932.

⁹G. Millington, A Modified Formula for Reverberation, J.A.S.A., 4, pp. 69-82, July, 1932.

¹⁰W. J. Sette, A New Reverberation Time Formula, J.A.S.A., 4, pp. 193-210, Jan., 1933.

which is merely Sabine's equation with $a_i = \ln(1 - \alpha_i)$. This equation falls into trouble by predicting $T=0$ when there is a patch of perfectly absorbing material, no matter how small. As V. O. Knudsen¹¹ says, "The approximate theories, when used with caution and understanding, have served satisfactorily for practical purposes of acoustical designing, and they will continue to do so until they are superseded by more exact theories."

The more complex acoustical wave theory as presented by such individuals as T. V. Hunt, L. L. Beranek, and D. Y. Maa¹² and P. M. Morse and R. H. Bolt¹³ has cleared up many of the problems in room acoustics raised in the various geometric theories. This paper deals with the geometric theory as it is felt that the limitations imposed upon its use for significant results are not severely restrictive in application to underwater work. A uniform coverage of a regularly constructed test tank very closely simulates the actual conditions under which the material will be employed. A diffuse sound field, as defined by equal probability of propagation in all directions and equal intensity levels at all locations, was not difficult to obtain at frequencies less than 25 KC by making use of a filtered noise signal.

It is becoming increasingly difficult to measure the characteristics of the larger and lower frequency transducers in the test tanks designed for the higher frequencies of the past. Young¹⁴ presents three different forms

¹¹V. O. Knudsen, Recent Developments in Architectural Acoustics, Rev. Mod. Phys., 6, p. 3, Jan., 1934.

¹²F. V. Hunt, L. L. Beranek, and D. Y. Maa, Analysis of Sound Decay in Rectangular Rooms, J.A.S.A., 11, pp. 80-94, July, 1939.

¹³P. M. Morse and R. H. Bolt, op. cit. pp. 81-146.

¹⁴R. W. Young, op. cit. pp. 916-917.

of power equations to obtain sound power output of a transducer by measurement of a decay rate, a steady state sound pressure, and an average absorption coefficient in the enclosure under consideration. One form, suitable for use in a reverberant enclosure, may be obtained by operating on the differential equation of conservation of energy in the following manner. The solution for equation (3) for the source turned on at $t=0$ and run for a "long" time is

$$\langle E \rangle = \frac{4W}{c\bar{a}S} \quad (11)$$

The general relationship¹⁵ between the time and space averaged sound energy density and squared sound pressure p^2 is

$$\langle E \rangle = \frac{p^2}{\rho c^2} \quad (12)$$

Equating (11) and (12) produces

$$W = \frac{p^2 \bar{a} S}{4\rho c} \quad (13)$$

which is a good approximation for finding the power output of a transducer in a reverberant enclosure. A more versatile form of the power equation developed by Young is

$$W = \frac{p^2 V D}{4.34 \rho c^2} \cdot \left[\frac{1 - e^{-\bar{a}}}{\bar{a}} \right] \quad (14)$$

where p^2 is the average squared pressure in the enclosure, V is the volume, D is the measured decay rate, \bar{a} is the average Sabine coefficient,

¹⁵ P. M. Morse, Vibration and Sound, p. 384, McGraw-Hill Book Co., 1948.

ρ is the density of the medium, and c is the sound velocity of the medium. This equation is based upon a discontinuous process of energy density decay and is relatively free from theoretical uncertainties as the quantity in the brackets does not change rapidly with the amount of absorption present. Its derivation follows:

$$\langle E \rangle = \frac{4W}{c \bar{\alpha} S} \quad (15)$$

for a discontinuous process as explained by Sabine¹⁶. Equating (12) and (15) yields

$$W = \frac{p^2 \bar{\alpha} S}{4\rho c} \quad (16)$$

which is the third form of the power equation presented by Young. The same restrictions must be applied to equation (16) as to equation (8).

Now using the relationship

$$\begin{aligned} \bar{\alpha} &= -\ln(1 - \bar{\alpha}) \\ \bar{\alpha} &= 1 - e^{-\bar{\alpha}} \end{aligned} \quad (17)$$

and equation (6) to substitute into equation (16) gives

$$W = \frac{p^2 VD}{4.34 \rho c^2} \cdot \left[\frac{1 - e^{-\bar{\alpha}}}{\bar{\alpha}} \right] \quad (14)$$

¹⁶R. W. Young, op. cit. p. 916.

3. Description of Tank and Lining Material.

A small free standing tank (1.8 x 1.2 x 0.6 meters) was used in making the reverberation measurements. It was constructed from 0.004 meter thick "black iron" sheeting and set upon 0.02 meter thick rubber blocks atop 0.15 meter wooden blocks.

An unlined tank, its interior painted with a glossy enamel paint, was first investigated. The second condition under which the tank was studied was with it fully lined, including the surface, with a cone lattice structured aluminum loaded butyl rubber lining.¹⁷ The lining was composed of 0.2 x 0.4 meter blocks which were laid on the floor, stacked tight against the walls and suspended from a framework over the surface. The surface blocks were barely covered with water. Figure 1 presents typical views of the cone lattice structured material. A. Heller¹⁸ indicates an average reflectivity in db for the frequencies studied in this report. They are as follows:

Freq. (KC)	20	50	100
R (db)	-21	-24.5	-24

These values were obtained by pulse technique from samples attached to a 0.003 meter brass plate, backed by corprene, and suspended 0.5 meter below the surface of the test tank. An absorption coefficient for the respective

¹⁷A. Heller, Underwater Anechoic Tank Linings, NAVORD Report 2989 (Confidential), U. S. Naval Ordnance Laboratory, White Oak, Maryland, pp. 19-22, 10 Nov., 1953.

¹⁸Ibid. p. 76.

reflectivity figures are determined from the equation¹⁹

$$\alpha = 1 - \log_{10}^{-1}\left(\frac{R}{10}\right)$$

The absorption coefficients were calculated to be

Freq. (KC)	20	50	100
α	0.992	0.996	0.996

The third condition under which the tank was examined was with the cone lattice structured material mounted backwards, i.e., cones facing the tank walls. This presented an intermediate state between the reverberant unlined tank and the tank containing the absorbent material installed as intended. No reflectivity figures were available for the material so utilized.

¹⁹Ibid. p. 32.

4. Description of Equipment.

The equipment used for producing and receiving a gated narrow band noise signal to measure the decay rate of the tank is illustrated in Figure 2.

The low level noise signal was filtered to $\pm 5\%$ of center frequency; then switched on and off at the fastest rate allowable for full build up and decay of the sound field. The low level gated signal was then amplified and transmitted into the water by an LC 32 hydrophone. The receiving portion of the equipment consisted of another LC 32 hydrophone followed by a low level amplifier, a band pass filter, a logarithmic amplifier, and a "Memo-scope". The vertical amplifier of the "Memo-scope" was calibrated in db to facilitate reading the decay rate in db/sec. The "Memo-scope's" storage facility was extremely useful in allowing the integrating effect of repeated sweeps even at low repetition rates of one per second. Photographs were taken to preserve data. A square wave generator was used to actuate the electronic switch and to synchronize the various oscilloscope presentations. A dual trace oscilloscope monitored the input and output signals for detection of distortion. An ellipsoid shaped ballon (0.17 x 0.25 meter) located in the center of the tank provided diffusion of the sound field. This arrangement was capable of working with a decay rate as high as 200,000 db/sec. The signal-to-noise ratio, however, was limited to 50 db by the logarithmic amplifier.

The same equipment was employed in making power output measurements except that a continuous signal instead of a gated signal was used.

5. Measurements.

A filtered noise signal was selected to diminish the problem of standing waves. Measurements made in an unlined tank indicate an approximated 25 db reduction of SWR to less than two db with the use of a $\pm 5\%$ of center frequency filtered noise signal as compared with a sine wave signal.

An air filled balloon was suspended in the tank to aid in diffusion of the sound field at higher frequencies. It allowed a more effective use of the receiving equipment when it was placed between the transmitting and receiving hydrophones by blocking the direct sound field, thus eliminating the initial 10 to 15 db drop in signal due to cessation of the direct signal when operating with a highly absorbent lining. Decay rates measured in an unlined tank with and without the balloon indicate that it contributed about 50 db/sec which was negligible compared with 9,000 to 25,000 db/sec decay rates obtained with a highly absorbent lining.

The tank lining conditions were kept uniform, i.e. completely unlined, fully lined with cone lattice structured material facing in, or fully lined with the flat base of the cone lattice structured material facing in. Problems of fringe and location effects of small samples and of how to average the absorption coefficients were therefore ruled out. All of these effects were observed during preliminary work.

All equipment was checked out and calibrated as required before the experimental work commenced. Periodic checks were made throughout the experiment and upon completion of the work to insure uniform performance of the equipment.

Care was exercised to insure that the signals operated on were free from distortion and of a linear nature, i.e. a two db increase in input voltage produced a two db increase in received voltage.

The frequency content of the input and received signals as analyzed with a 1/3 octave spectrometer were identical within one db.

An error in measuring a filtered noise signal was minimized by employing the same technique for both the input voltage and the output voltage used for pressure determination.

Transducer output efficiencies were used for comparison rather than power output measurements in order to eliminate any error caused by differences between the types of signal employed in pulse measurements and reverberation measurements. The same power input level was maintained in both cases.

6. Results.

Photographs were taken of the decay rates of an unlined tank and the lined tank with and without the balloon. See Figures 3,4, and 5. The decay rates observed for three conditions of lining are shown in Table 1.

Table 1

DECAY RATES OBSERVED FOR VARIOUS TANK LININGS

Freq.	Unlined	Flat Lining (with balloon)	Cone Structured Lining (with balloon)
10 KC	55 db/sec	7,000 db/sec	8,000 db/sec
20	60	8,000	14,300
50	87	14,300	22,200
100	111	16,200	25,000

A sample calculation is made for the Sabine coefficient and absorption coefficient at 50 KC for the tank lined with the cone structured material installed as intended and with the balloon suspended in the tank. Surface area = 8.14 m². Volume = 1.34 m³. Sabine's coefficient is obtained from equation (6):

$$D = \frac{1.086 c \bar{a} S}{V}$$

$$\bar{a} = \frac{DV}{1.086 c S} = \frac{22,000 \times 1.34}{1.086 \times 1.48 \times 10^3 \times 8.14} = 2.28$$

The absorption coefficient as advanced by Eyring is computed from equation (8):

$$D = \frac{-1.086 c S \ln(1 - \bar{\alpha})}{V}$$

$$\ln(1 - \bar{\alpha}) = -\bar{a}$$

$$\bar{\alpha} = 1 - e^{-\bar{a}} = 1 - e^{-2.28} = 0.898$$

The Sabine coefficients (\bar{a}) and absorption coefficients ($\bar{\alpha}$) for the decay rates observed in Table 1 are presented in Table 2.

Table 2

SABINE COEFFICIENTS AND ABSORPTION COEFFICIENTS
AS MEASURED BY REVERBERATION TECHNIQUE

Freq. KC	Unlined		Flat Lining		Cone Structured Lining	
	\bar{a}	$\bar{\alpha}$	\bar{a}	$\bar{\alpha}$	\bar{a}	$\bar{\alpha}$
10	0.00565	0.00565	0.72	0.513	0.82	0.56
20	0.00615	0.00615	0.82	0.56	1.47	0.77
50	0.0089	0.0089	1.47	0.77	2.28	0.898
100	0.0113	0.0114	1.66	0.81	2.56	0.926

The transducer efficiency at 50 KC in an unlined tank was computed using transducer output power from equation (14):

$$W = \frac{p^2 VD}{4.34 \rho c^2} \cdot \left[\frac{1 - e^{-\bar{a}}}{\bar{a}} \right]$$

Where $p=87 \text{ n/m}^2$ (obtained from the open circuit voltage reading of the calibrated receiving hydrophone), $V=1.34 \text{ m}^3$, $\rho c^2=2.185 \times 10^9 \text{ kilogram/meter-sec}^2$, $D=87 \text{ db/sec}$ from Table 1, and $\bar{a}=0.0089$ from Table 2. Substitution of the above values gives

$$W_{\text{out}} = \frac{87^2 \times 1.34 \times 87}{4.34 \times 2.185 \times 10^9} \cdot \left[\frac{0.0087}{0.0087} \right] = 9.28 \times 10^{-5} \text{ watts}$$

The power into the transducer was computed from the voltage input (2.44 volts rms) and parallel resistance of the hydrophone from Table 5.

$$W_{\text{in}} = \frac{E^2}{R} = \frac{2.44^2}{1.56 \times 10^3} = 3.82 \times 10^{-3} \text{ watts}$$

The efficiency calculation is as follows:

$$\eta = \frac{W_{\text{out}}}{W_{\text{in}}} \times 100\% = \frac{9.28 \times 10^{-5}}{3.82 \times 10^{-3}} \times 100\% = 2.43\%$$

as compared with 24.6% obtained by pulse technique for 50 KC. See Appendix I for the calculation of this figure. The transducer efficiencies as

determined by Young's theory for the three different tank conditions are compared in Table 3 with the efficiencies obtained by pulse technique.

Table 3

TRANSDUCER EFFICIENCIES

Freq.	Pulse Tech.	Unlined	Flat Lining	Cone Struct. Lining
10 KC	8.5%	1.14%	0.477%	0.234%
20	27.2	6.55	4.72	0.171
50	24.6	2.43	0.562	0.302
100	2.3	2.39	0.778	0.662

7. Conclusions.

The use of the "Memo-scope" for reading decay rates proved to be a very versatile method since it allowed long integration times for smoother results. It was not limited by a mechanical writing speed. A conservative estimate of 200,000 db/sec as an upper response limit was set only by the characteristics of the preceding electronic equipment. Preservation of results was possible by the taking of Polaroid photographs of the "Memo-scope" presentation.

Table 4 presents a comparison of values of absorption coefficients of the cone structured material as determined from Eyring's reverberation formula, by pulse technique (See Appendix II), and from Heller's published information.

Table 4

ABSORPTION COEFFICIENTS OF CONE STRUCTURED MATERIAL

Freq. (KC)	$\bar{\alpha}$ (reverb.)	α (pulse)	α (pub)
10	0.56	0.782-0.945	---
20	0.77	0.710-0.927	0.992
50	0.898	0.796-0.946	0.996
100	0.926	0.961-0.999	0.996

In comparing the values of $\bar{\alpha}$ obtained by the reverberation technique with those obtained by the pulse technique it should be remembered that $\bar{\alpha}$ (reverb.) is an "average" absorption coefficient for random angles of incidence, while α (pulse) is for normal incidence Appendix II points out that the values of α (pulse) are rather crude and should be used only in comparison of the order of magnitude of $\bar{\alpha}$. A correction for scattering was not measured on the samples used but typical values were extracted from Heller's work. The discrepancy between $\bar{\alpha}$ (reverb.) and

α (pub.) may be accounted for by variations between samples (including films which may have formed on their surfaces), by variation in mounting conditions, or by variation in the water used. α (pub.) was based on Heller's assumption of axial symmetry. This assumption is not valid in that the geometry of the cone lattice structure is not axially symmetric. Furthermore, Heller's sample was rectangular rather than circular which would also disturb the symmetry of Fresnel diffractions²⁰. See Figure 8 for the geometry of Fresnel half period zones. In view of the above, the disagreement with α (pub.) does not impair the validity of the results of this investigation.

The significant information to be taken from Table 4 is that many values of $\bar{\alpha}$ (reverb.) are greater than 0.63 (Sabine coefficient value of unity). Sabine absorption coefficient values up to 2.56 were consistently obtained in the work performed, thus substantiating Eyring's theory. The authors question the disproportionately large number of materials listed by the Acoustical Material Association Bulletin to have a Sabine coefficient of 0.99. It is believed that many of these must have been measured as greater than unity and reduced out of deference to Sabine's postulated limit.

The reverberation techniques developed in air appear feasible for use in water for measuring absorption coefficients. A small tank may be used, thus allowing complete coverage of all surfaces by the material to be tested, thereby eliminating any problem of averaging absorption coefficients. The complete coverage of the tank simulates the conditions

²⁰F. A. Jenkins and H. E. White, Fundamentals of Optics, pp. 349-353, McGraw-Hill Book Co., 1950.

under which the material will actually be used. This method also offers an important consideration when testing materials under pressure in that the hydrophones do not have to be positioned to measure specular reflections. This rules out the need for piercing the pressure chamber for mechanical positioning devices.

Young's theory presented a most promising method of meeting the more strenuous demands of low frequency measurements in test tanks designed for sonar frequencies of the past. In an unlined tank all the conditions assumed by Young for power measurements were present, yet even in this instance there was no correlation with the results obtained by pulse technique. Furthermore, the results obtained under various conditions of tank lining were not consistent (See Table 3). This theory was assiduously investigated, but within the time available satisfactory results were unobtainable.

BIBLIOGRAPHY

1. P. E. Sabine, The Measurement of Sound Absorption Coefficients, J.F.I., 207, pp. 341-368, Mar., 1929.
2. C. F. Eyring, Reverberation Time in "Dead" Rooms, J.A.S.A., 1, pp. 217-241, Jan., 1930.
3. R. F. Norris, Application of Norris-Andree Method of Reverberation Measurement to Measurements of Sound Absorption, J.A.S.A., 3, pp. 361-370, Jan., 1932.
4. C. A. Andree, The Effect of Position on the Absorption of Materials for the Case of a Cubical Room, J.A.S.A., 3, pp. 535-551, April, 1932.
5. V. O. Knudsen, Architectural Acoustics, John Wiley & Sons, 1932.
6. G. Millington, A Modified Formula for Reverberation, J.A.S.A., 4, pp. 69-82, July, 1932.
7. C. F. Eyring, Methods of Calculating the Average Coefficient of Sound Absorption, J.A.S.A., 4, pp. 178-192, Jan., 1933.
8. W. J. Sette, A New Reverberation Time Formula, J.A.S.A., 4, pp. 193-210, Jan., 1933.
9. V. O. Knudsen, Recent Developments in Architectural Acoustics, Rev. Mod. Phys., 6, pp. 1-22, Jan., 1934.
10. R. M. Morris, G. M. Nixon, and J. S. Parkinson, Variations in Sound Absorption Coefficients as Obtained by the Reverberation Chamber Method, J.A.S.A., 9, pp. 234-243, Jan., 1938.
11. P. M. Morse, Some Aspects of the Theory of Room Acoustics, J.A.S.A., 11, pp. 56-66, July, 1939.
12. F. V. Hunt, L. L. Beranek, and D. Y. Maa, Analysis of Sound Decay in Rectangular Rooms, J.A.S.A., 11, pp. 80-94, July, 1939.
13. P. E. Sabine, Specific Normal Impedances and Sound Absorption Coefficients of Material, J.A.S.A., 12, pp. 317-322, Jan., 1941.
14. P. M. Morse and R. H. Bolt, Sound Waves in Rooms, Rev. Mod. Phys., 16, pp. 69-149, Jan., 1944.
15. P. M. Morse, Vibration and Sound, McGraw-Hill Book Co., 1948.
16. A. Heller, Underwater Anechoic Tank Linings, NAVORD Report 2989 (Confidential), U. S. Naval Ordnance Laboratory, White Oak, Maryland, 10 Nov., 1953.
17. L. L. Beranek, Acoustics, McGraw-Hill Book Co., 1954.

18. R. W. Young, Sabine Reverberation Equation and Sound Power Calculations, J.A.S.A., 31, pp. 912-921, July, 1959.
19. Tentative Method of Test for Sound Absorption of Acoustical Materials in Reverberation Rooms, ASTM Designation: C 423 - 60 T, 1960 Supplement to Book of ASTM Standards, Part 5, American Society for Testing Materials, 1960.
20. Sound Absorption Coefficients of Architectural Acoustical Materials, Acoustical Materials Association, Bulletin XXI, A.I.A. No. 39-b, 1961.

APPENDIX I

HYDROPHONE CALIBRATION

Atlantic Research Corporation hydrophones, Model LC 32, were used throughout. The receiving hydrophone was calibrated by the application of pulse technique and the electro-acoustic reciprocity theorem. The open circuit receiving response obtained in db reference one volt/ μ bar was:

Freq. (KC)	10	20	50	100
db	-104.4	-105.9	-105.4	-107.8

The parallel a.c. resistance values measured are listed in Table 5 for the various frequencies and tank conditions.

Table 5

HYDROPHONE RESISTANCE MEASUREMENTS

Freq.	Unlined	Flat Lining	Cone Structured Lining
10 KC	39 K	34.4 K	35 K
20	16.3	14.4	12.5
50	1.56	1.93	1.79
100	1.41	1.57	1.28

The calculation of the transducer efficiency using pulse technique was as follows: For a spherical wave the Intensity = $p^2/\rho c$. Integrating this over the surface of a sphere with the source at the center will give the power output. See Figure 7 for the geometry of the integration required. Cylindrical symmetry exists with the LC 32 hydrophone. The pressure measured at an angle θ from the axis of the transducer will exist at all points at that distance and angle, making a band of width $rd\theta$ and circumference $2\pi r\sin\theta$. Multiplying this element of area $dA=2\pi r^2 \sin\theta d\theta$ by the intensity present along it and integrating over θ from 0° to 180°

gives the power output

$$W = \frac{2\pi r^2}{\rho c} \int_0^{180^\circ} p^2 \sin\theta d\theta$$

The transmitting transducer was rotated and pressure was measured with the calibrated hydrophone every 10° at a distance of one meter. The directivity patterns obtained are plotted in Figures 8,9, 10, and 11.

The pressure was averaged over 10° increments for output power calculations, so chosen to give a reasonable degree of accuracy. The integral may be approximated in the following manner:

$$\int_0^{180^\circ} p^2 \sin\theta d\theta \cong \sum_{n=0}^{17} \left[-p_{10(n+\frac{1}{2})}^2 \cos\theta \right]_{10n}^{10(n+1)}$$

Increment ($^\circ$)	$\cos \theta_1 - \cos \theta_2$	$p(n/m^2)$	$-p^2(\cos \theta_1 - \cos \theta_2)$
0-10	-0.015	7.4	0.82
10-20	-0.045	7.4	2.46
20-30	-0.074	6.6	3.22
30-40	-0.1	4.72	2.23
40-50	-0.123	2.82	0.98
50-60	-0.143	3.98	2.26
60-70	-0.158	6.3	6.27
70-80	-0.168	8.4	11.85
80-90	-0.174	12.6	27.6
90-100	-0.174	14.4	36.1
100-110	-0.168	14.5	35.4
110-120	-0.158	13.8	30.1
120-130	-0.143	11.9	20.2
130-140	-0.123	8.9	9.72
140-150	-0.1	5.95	3.54

Increment (°)	$\cos \theta_1 - \cos \theta_2$	p (n/m ²)	$-p^2(\cos \theta_1 - \cos \theta_2)$
150-160	-0.074	4.3	1.37
160-170	-0.045	2.82	0.36
170-180	-0.015	2.11	<u>0.07</u>
			194.55

$$W_{out} = \frac{2\pi r^2}{\rho c} \int_0^{180} p^2 \sin \theta d\theta = \frac{2\pi \times 194.55}{1.48 \times 10^6} = 8.25 \times 10^{-4} \text{ watts}$$

The power into the transducer was computed from the voltage input (2.44 volts rms) and the parallel resistance of the hydrophone from Table 5.

$$W_{in} = \frac{E^2}{R} = \frac{2.44^2}{1.79 \times 10^3} = 3.35 \times 10^{-3} \text{ watts}$$

The efficiency calculation is

$$\eta = \frac{W_{out}}{W_{in}} \times 100\% = \frac{8.25 \times 10^{-4}}{3.25 \times 10^{-3}} \times 100\% = 24.6\%$$

A tabulation of transducer output efficiency follows:

Freq. (KC)	10	20	50	100
η %	8.5	27.2	24.6	2.3

APPENDIX II

ABSORPTION COEFFICIENT BY PULSE TECHNIQUE

The following technique was employed to secure an absorption coefficient by pulse technique. See Figure 14 for a block diagram of the equipment used. The reflectivity ratios measured were

Freq. (KC)	10	20	50	100
R_n (db)	-9.62	-8.38	-8.66	-21.12

The results are rather crude but they give a working value. Heller²¹ indicates that the normal reflection coefficient for the cone structured material is not the peak reflection coefficient but may be in error by many db. A table of corrections for scattering, based on Heller's work, follows²²

Freq. (KC)	10	20	50	100
\pm db	3	4	5	7

These corrections were applied to the R_n measured and the resulting reflectivity figures were then converted to absorption coefficients by the equation

$$\alpha = 1 - \log_{10}^{-1} \left(\frac{R}{10} \right)$$

A tabulation of the absorption coefficients achieved is

Freq. (KC)	10	20	50	100
α	0.782-0.945	0.710-0.927	0.796-0.946	0.961-0.999

²¹A. Heller, op. cit. p. 69.

²²A. Heller, op. cit. p. 76.

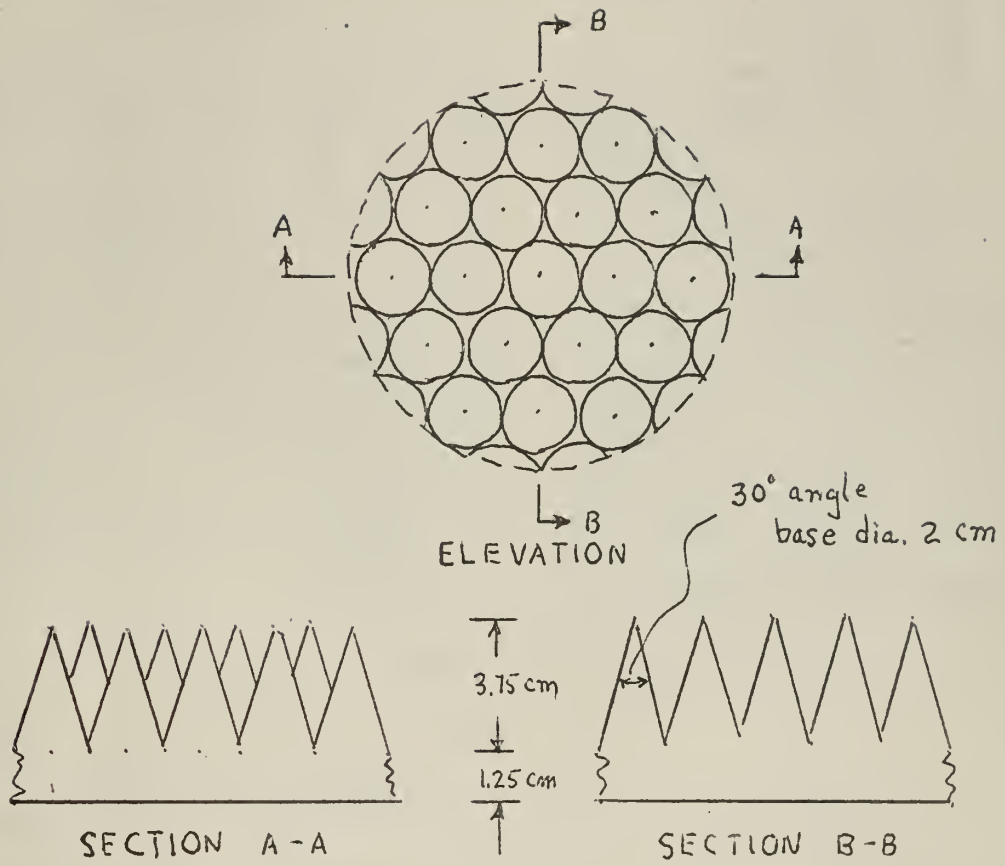

Figure 1
 Typical Views of Cone Lattice Structured Material

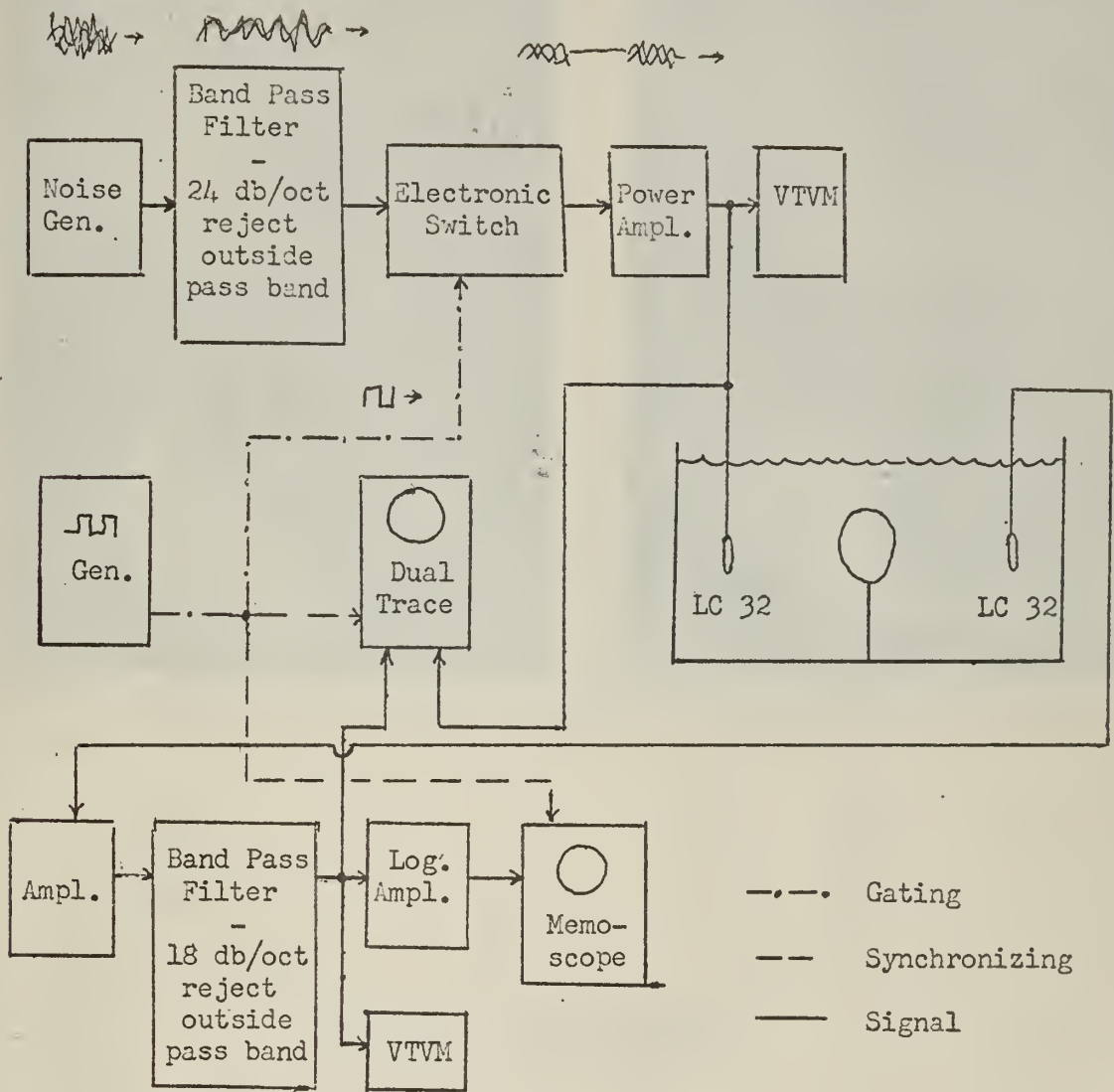

Figure 2

Block Diagram of Equipment Used for Reverberation Measurements



a. 50 KC
b. 20 KC



c. 10 KC
d. 100 KC

Scale:

Vertical: 5 db/division
Horizontal: .1 sec/division

Figure 3

Photographs of Decay Rates in an Unlined Tank
(no balloon)

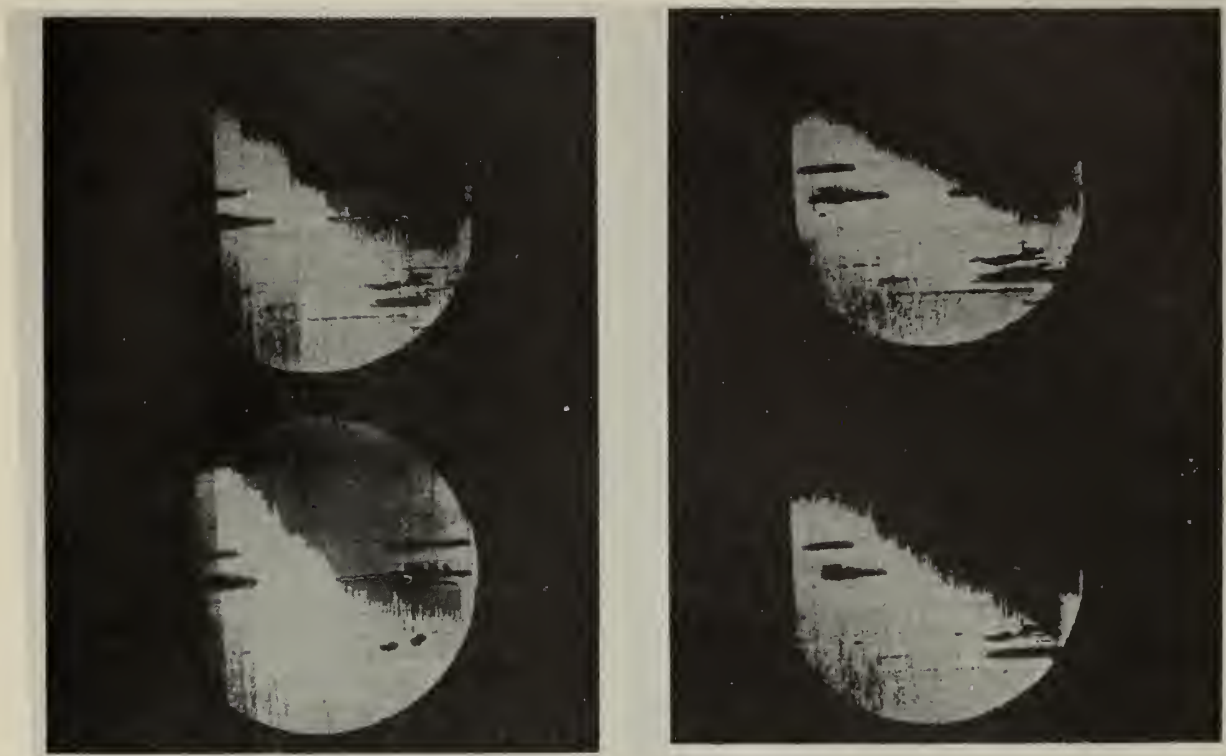

a. 20 KC - No balloon.

b. 20 KC - With balloon.

c. 10 KC - No balloon.

d. 10 KC - With balloon.

Scale:

Vertical: 5 db/ division

Horizontal: .5 msec/division

Figure 4

Photographs of Decay Rates with Flat Lining in the Tank
(10 KC and 20 KC)



- a. 100 KC - No balloon.
b. 100 KC - With balloon.

- c. 50 KC - No balloon.
d. 50 KC - With balloon.

Scale:

Vertical: 5 db/division
Horizontal: .5 msec/division

Figure 5

Photographs of Decay Rates with Flat Lining in the Tank
(50 KC and 100 KC)

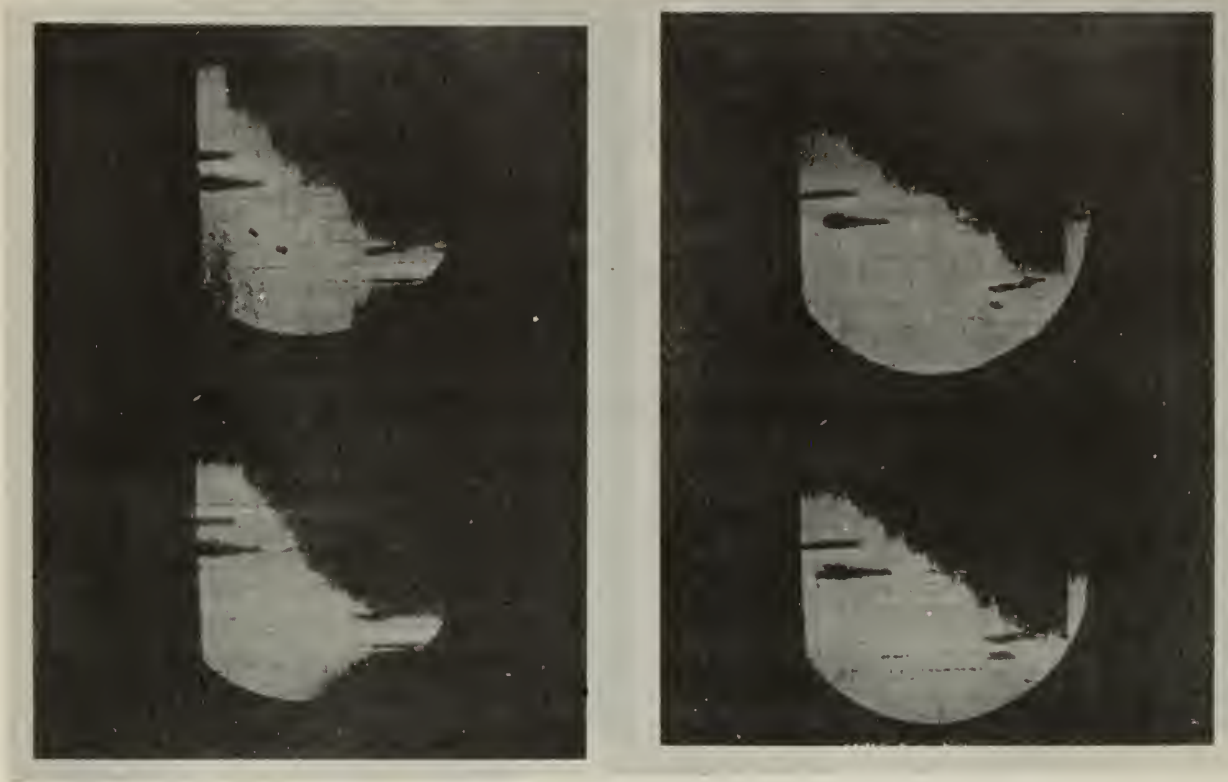

a. 20 KC - No balloon.

c. 10 KC - No balloon.

b. 20 KC - With balloon.

d. 10 KC - With balloon.

Scale:

Vertical: 5 db/division
 Horizontal: .5 msec/division

Figure 6

Photographs of Decay Rates with Cone Lattice Structured
 Lining in the Tank (10 KC and 20 KC)



- a. 100 KC - No balloon.
 b. 100 KC - With balloon.

- c. 50 KC - No balloon.
 d. 50 KC - With balloon.

Scale:

Vertical: 5 db/division
 Horizontal: .5 msec/division

Figure 7

Photographs of Decay Rates with Cone Lattice Structured
 Lining in the Tank (50 KC and 100 KC)

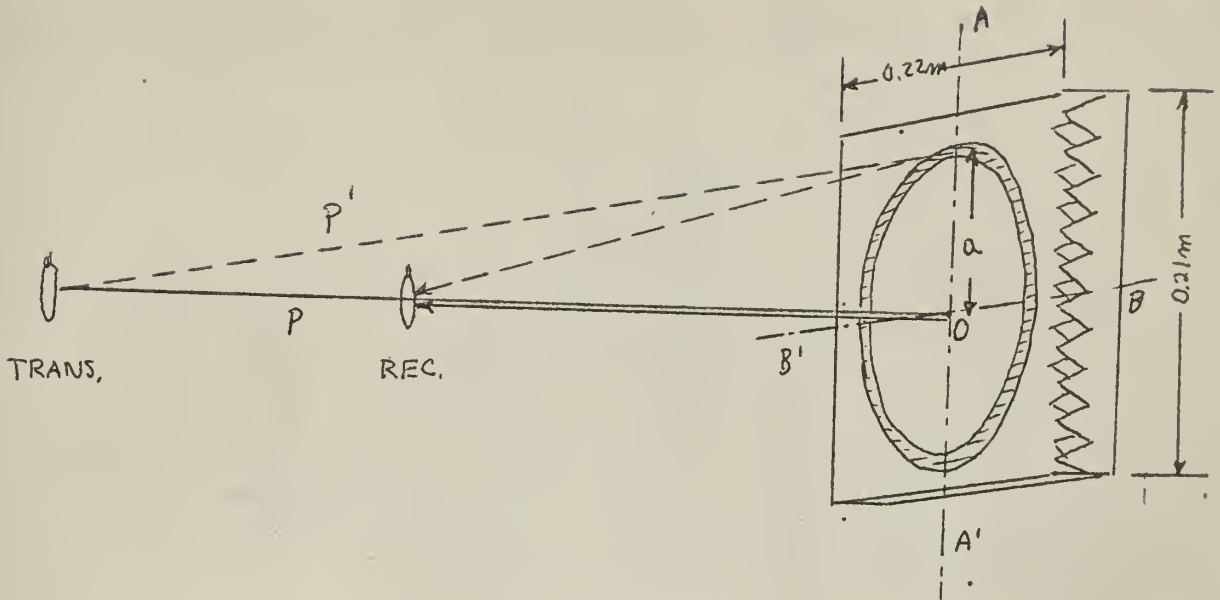

$$\Delta P = P' - P = \frac{\lambda}{2}$$

$$P = 1.25 \text{ m.}$$

At 50 KC $\Delta P = 0.0148 \text{ m.}$, $P' = 1.264 \text{ m.}$, and $a = 0.09 \text{ m.}$ for 180° phase shift with respect to reflection on the axis.

Note: The sample dimensions are those of Heller's work. His reflection measurements were obtained by swinging the receiving hydrophone in an arc about O in the AA' and BB' planes.

Figure 8

Geometry of Destructive Interference Patterns in Pulse Technique Measurements

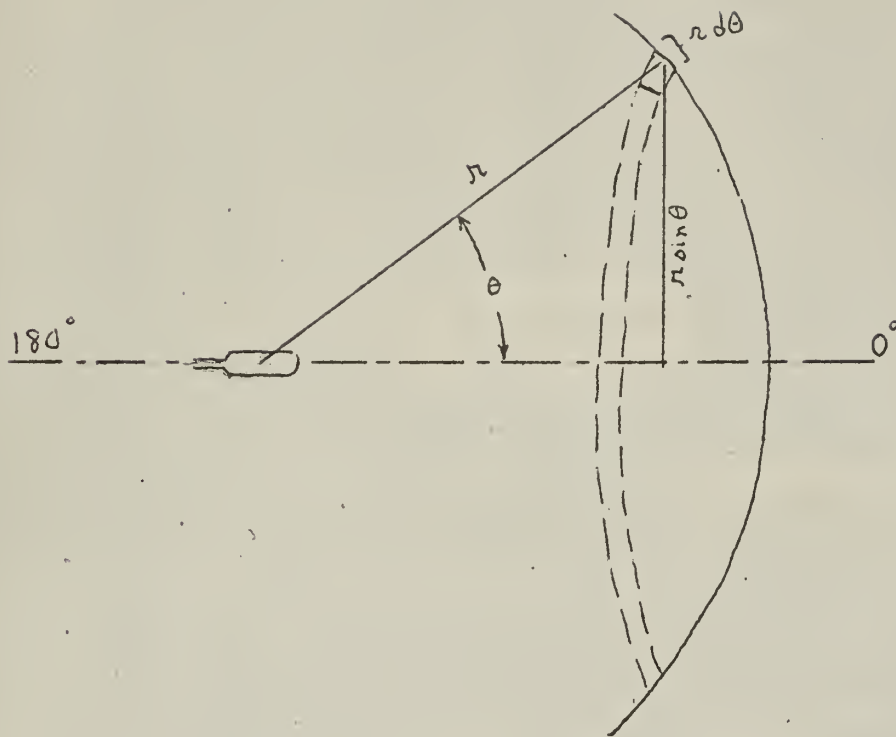

Figure 9

Geometry of Integration for Power Measurement by Pulse Technique

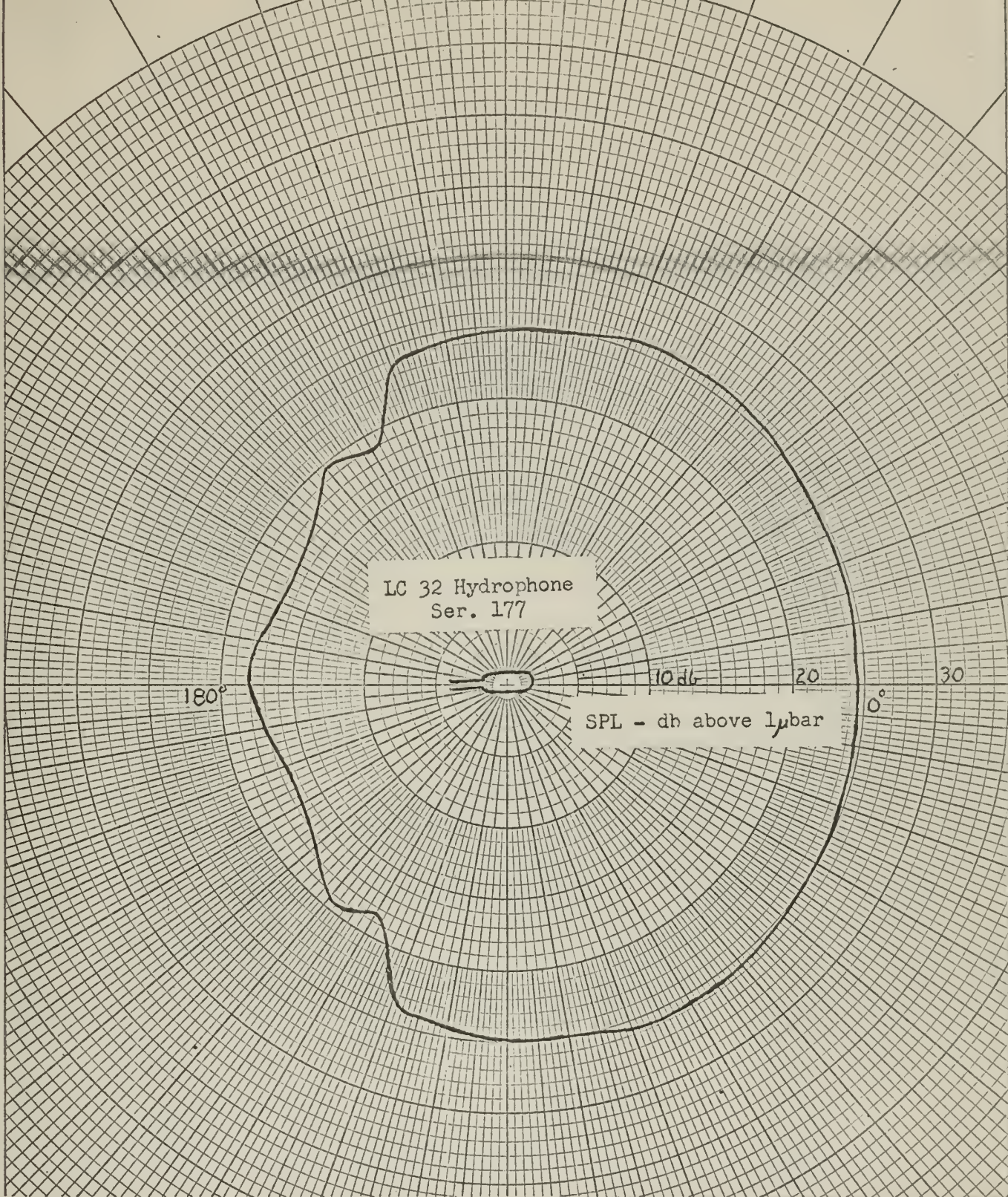

Figure 10

Directivity Pattern of LC 32 Hydrophone at 10 KC

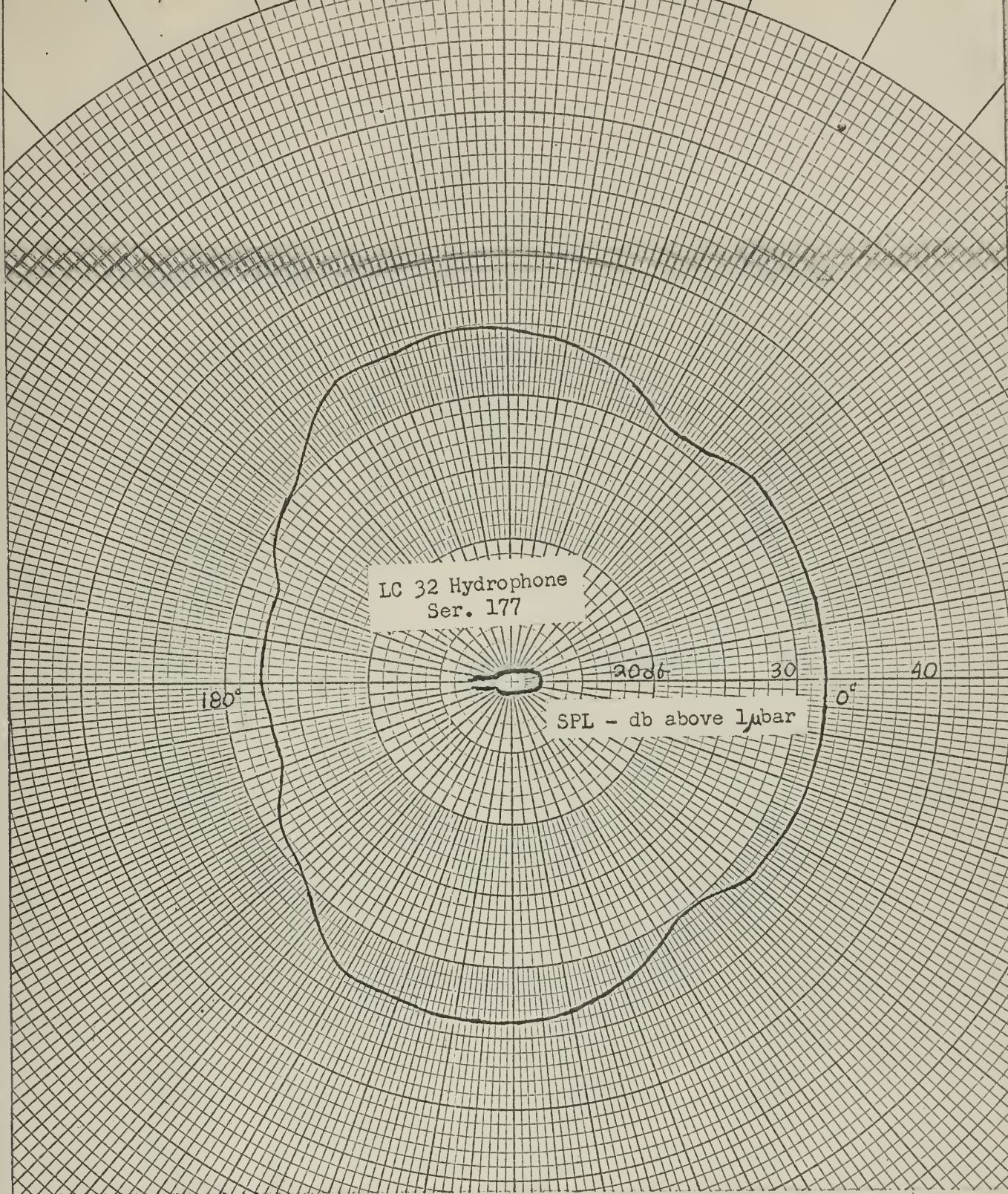

Figure 11

Directivity Pattern of LC 32 Hydrophone at 20 KC

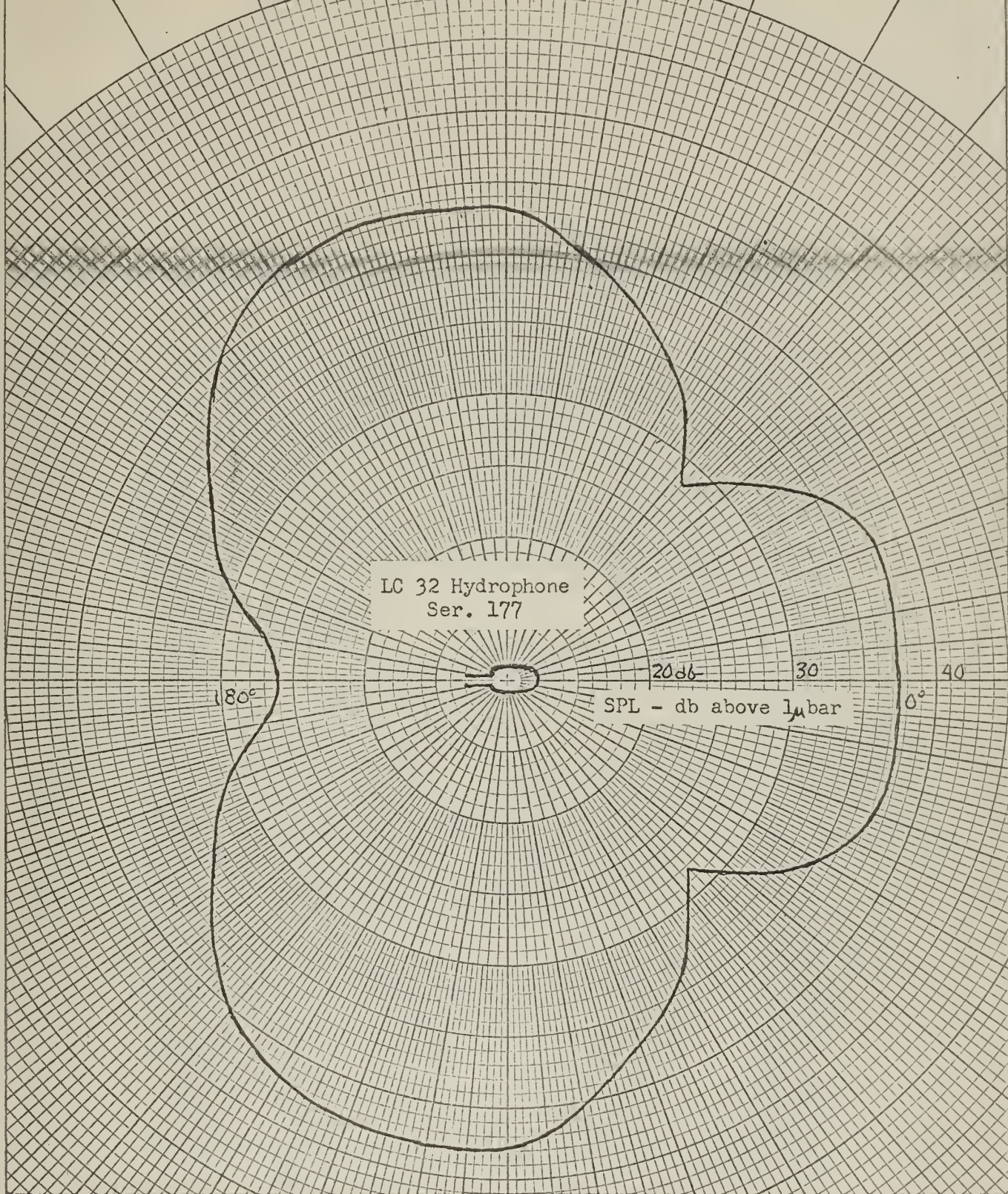

Figure 12

Directivity Pattern of LC 32 Hydrophone at 50 KC

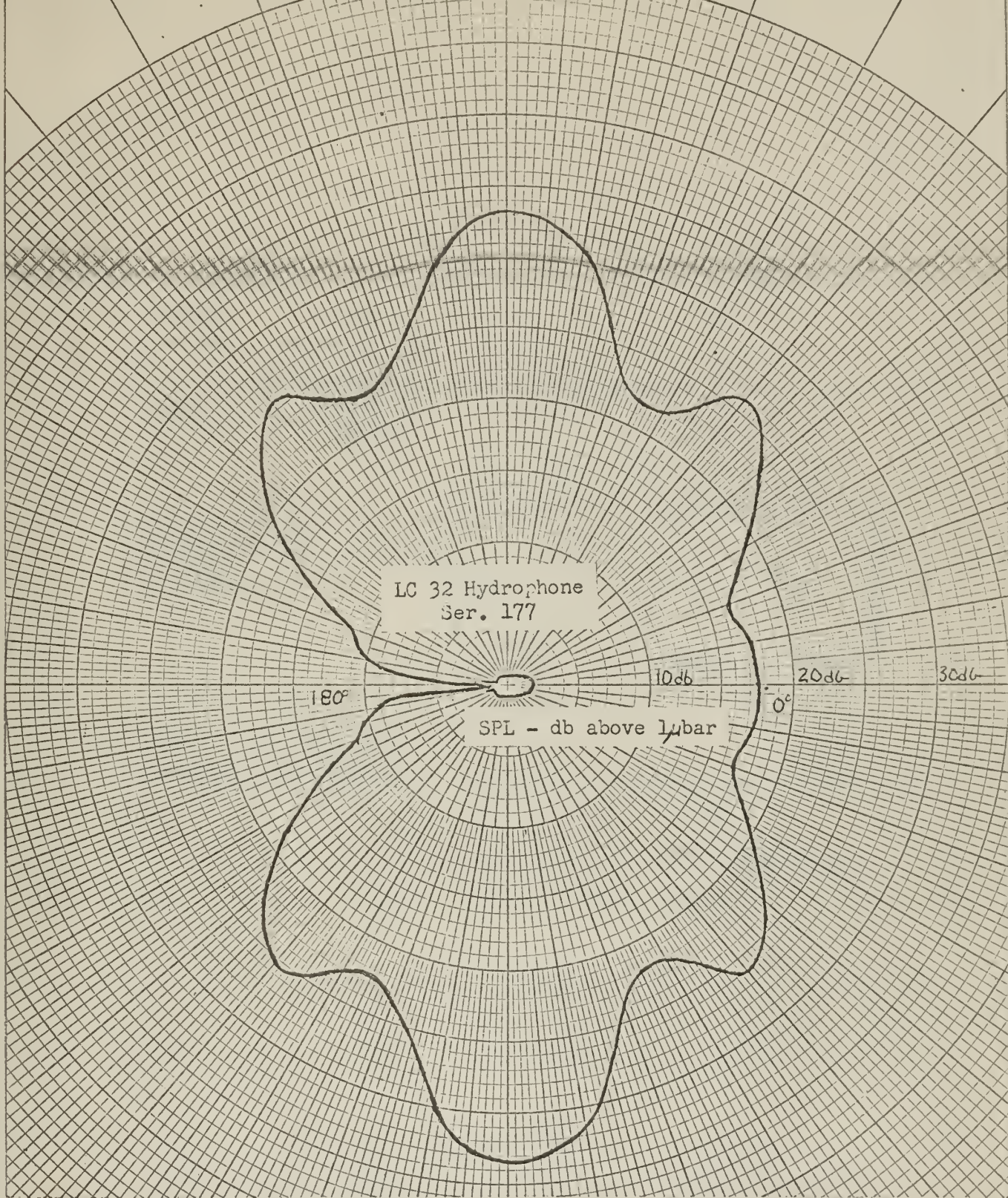

Figure 13

Directivity Pattern of LC 32 Hydrophone at 100 KC

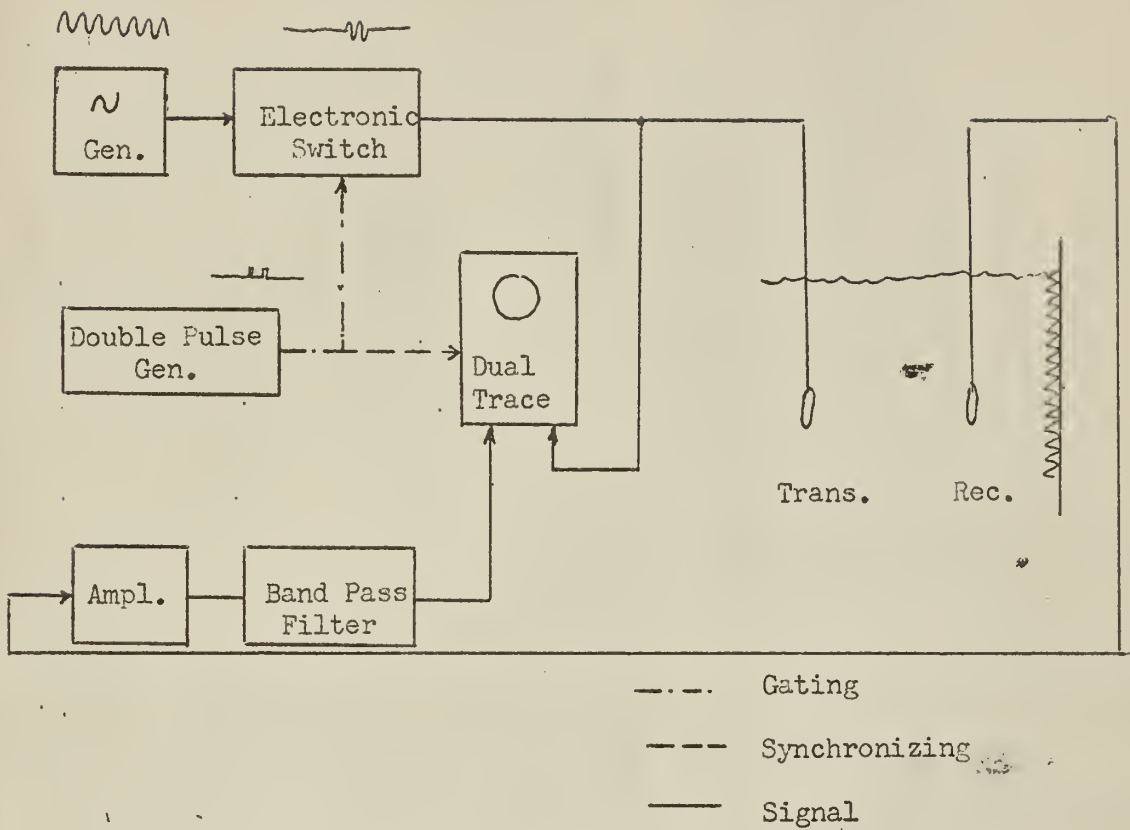

Figure 14

Block Diagram of Equipment Used for Pulse Technique Measurements

thesC2746

Investiation and application of

DUDLEY KNOX LIBRARY



3 2768 00421948 5

DUDLEY KNOX LIBRARY