

UNCLASSIFIED

AD NUMBER

AD482264

LIMITATION CHANGES

TO:

Approved for public release; distribution is unlimited.

FROM:

Distribution authorized to U.S. Gov't. agencies and their contractors;
Administrative/Operational Use; 1962. Other requests shall be referred to U.S. Naval Postgraduate School, Monterey, CA 93943.

AUTHORITY

USNPS ltr, 16 Nov 1971

THIS PAGE IS UNCLASSIFIED

NPS ARCHIVE
1962
REISINGER, J.

THE INFRARED SPECTRUM OF
H²O IN NON-POLAR SOLVENTS

JOHN E. REISINGER

LIBRARY
U.S. NAVAL POSTGRADUATE SCHOOL
MONTEREY, CALIFORNIA

THE INFRARED SPECTRUM
OF H₂O
IN NON-POLAR SOLVENTS

John E. Reisinger

THE INFRARED SPECTRUM

OF H_2O

IN NON-POLAR SOLVENTS

by

John E. Reisinger

Lieutenant, United States Navy

Submitted in partial fulfillment of
the requirements for the degree of

MASTER OF SCIENCE

United States Naval Postgraduate School
Monterey, California

1962

LIBRARY
U.S. NAVAL POSTGRADUATE SCHOOL
MONTEREY, CALIFORNIA

THE THESIS OF

BY

THE AUTHOR'S SERVICE

IS

John S. Weisinger

//

This work is accepted as fulfilling
the thesis requirements for the degree of

ASSISTANT PROFESSOR

from the

United States Naval Postgraduate School

ABSTRACT

The infrared spectrum of H_2O in dilute solution in each of two non-polar solvents, carbon tetrachloride and carbon disulfide, was obtained employing a Perkin-Elmer double beam spectrophotometer Model #221 with NaCl prism-grating interchange. The five-centimeter-pathlength liquid absorption cell designed for containing the samples is described, as are the various attempts to dry each solvent. Also discussed is a detailed method for preparing a correction curve for this spectrophotometer.

The asymmetric stretching vibration for the isolated H_2O molecule in carbon tetrachloride, ν_3 , was found at 3705 cm^{-1} ; the symmetric stretching vibration, ν_1 , was observed at 3613 cm^{-1} . In carbon disulfide these values were 3695 and 3603 cm^{-1} respectively. An unsuccessful attempt was made to locate the bending vibration, ν_2 , of the isolated H_2O molecule.

Two bands of lesser intensity were obtained at about 3800 and 3540 cm^{-1} by graphical separation of the absorption spectrum, and possible explanations for these bands were proposed.

The writer wishes to express his appreciation for the assistance and encouragement given him by Professor John W. Schultz of the United States Naval Postgraduate School in this investigation.

TABLE OF CONTENTS

Section	Title	Page
1.	Introduction	1
	a. Hydroxy Bodies in Dilute Solutions in Non-Polar Solvents	1
	b. Water; A Special Case	3
2.	Experimental Procedure	6
	a. Correction Curve	6
	b. Infrared Absorption of Water Dissolved in Carbon Tetrachloride	9
	c. Infrared Absorption of Water Dissolved in Carbon Disulfide	20
	d. Investigation of the Bending Region	21
3.	Results and Discussion	24
4.	Bibliography	32

LIST OF ILLUSTRATIONS

Figure		Page
1.	Correction Curve for the Perkin-Elmer Double-Beam Spectrophotometer Model #221 with NaCl Prism-Grating Interchange	10
2.	Five-Centimeter-Pathlength Absorption Cell	11
3.	Absorption of Dilute Solutions of Water in Carbon Tetrachloride	17
4.	Absorption of Water Vapor in the Region 3900 - 3200 cm^{-1}	17
5.	Absorption of Dilute Solutions of Water in Carbon Tetrachloride (after correcting for the absorption of the dry solvent)	18
6.	Absorption of Dilute Solutions of Water in Carbon Disulfide (after correcting for the absorption of the dry solvent)	22
7.	Modes of Vibration of the Isolated Water Molecule	24
8.	Graphical Separation of the Absorption Bands of Water in Carbon Tetrachloride	27

INTRODUCTION

a. HYDROXY BODIES IN DILUTE SOLUTION IN NON-POLAR SOLVENTS

In past years much information has been accumulated concerning the infrared absorption of hydroxy bodies in the region 2.5 to 3.5 μ . Errera and Mollet¹, in working with liquid aliphatic alcohols, attributed a large and intense band at 2.95 μ to a fundamental hydroxyl vibration. With dilute solutions of the same alcohols in inert non-polar solvents, this large band disappeared completely whereas a new and well defined peak, the intensity of which increased with dilution, appeared at 2.76 μ . This latter band was proposed as the hydroxyl vibration in the isolated alcohol molecule.

Davies and Sutherland² obtained similar results in their study of various carboxylic acids. They discovered a broad band at 3.0 μ , which vanished on dilution, and a narrow, well defined band at 2.837 μ which formed in the dilute solutions of the carboxylic acid in a non-polar solvent.

These findings were explained on the basis of the association of the solute molecules.^{3,4} With dilution, the relative number of monomolecules increases, thereby causing an increase in the intensity of the narrow peak which has been suggested as being the hydroxyl vibration of the isolated solute molecule. On the other hand, the large band that disappears on dilution is due to intermolecular actions (e.g., the hydrogen atom of one molecule vibrating with the oxygen atom of another.) This is a simplified example of a hydrogen bond, a subject which in itself has been thoroughly investigated over the past two decades.

Fox and Martin⁵ studied dilute solutions of phenol in carbon

tetrachloride and observed the same general behavior as had the previous workers. They determined the characteristic hydroxyl vibration of the isolated phenol molecule to be 2.769μ . Further, they showed that at slightly higher concentrations this band is affected to some extent by the overlap of the broad association band, the center of which was found at 2.95μ . This latter band intensified, as in the alcohols and carboxylic acids, when the concentration increased and approached saturation.

Fox and Martin also discovered that the ratio of the optical density ($d = \log_{10} I_0/I$) for any given concentration to the optical density of the most dilute solution studied was nearly a constant over the spectrum range of the band of the hydroxyl vibration in the isolated solute molecules. By gathering data of this sort for a series of concentrations they showed that as the concentration increased, the number of molecules which are linked to produce the association band also increased, thus providing further proof that the intensity of this broad, intense association band was proportional to the number of polymeric or "linked" solute molecules.

In summary, it has been determined that the monomeric form of the solute gives a series of sharp absorption bands corresponding to the fundamental and overtone frequencies of the hydroxyl bond. At higher concentrations the molecules interfere with each other and modify the nature of these O-H vibrations. This polymeric form produces very broad absorption bands which are consistently found to the long wavelength side of the related sharp monomeric ones.

b. WATER: A SPECIAL CASE

Water, as a simple hydroxy body, has been thoroughly investigated by many workers. Its interpretation however is far from complete in many regions. Plyler and Sleator⁶ have discovered vibration-rotation bands of water vapor in the infrared of which those at 6.26μ (1595 cm^{-1}) and 2.66μ (3756 cm^{-1}) have been classified as fundamental. The former was designated as ν_2 , the bending vibration frequency, and the latter was designated ν_3 , the asymmetrical stretching frequency. The symmetrical stretching vibration frequency, ν_1 , has not been directly observed in the infrared spectrum of water vapor. However Bender⁷ and Johnston and Walker⁸ have located this vibration band in the Raman spectrum at 2.74μ (3654 cm^{-1}).

The liquid state is a quasi-crystalline state where the molecules undergo rotational oscillations and, under certain conditions, rotate freely. Debye⁹ has shown, however, that in liquid water the conditions for free rotation are not met. Large lattice interactions occur to prevent it, and these broaden and shift the centers of the liquid absorption bands in the infrared and produce the diffuse Raman bands which are so characteristic of liquid water.

It has been determined by Kinsey and Ellis¹⁰ that these interactions can be greatly reduced by dissolving water in suitable non-polar solvents. In such solvents the infrared absorption bands sharpen and shift back toward their vapor positions.

Carbon disulfide was chosen as the solvent by Kinsey¹¹ and Ellis because of the relatively high solubility of water in it and because of its freedom from obscuring bands of its own in the region concerned.

Utilizing a Hilgar rocksalt spectrometer with a slit width of 0.04μ these investigators obtained 2.65μ (3770 cm^{-1}) and 2.80μ (3570 cm^{-1}) as the two stretching vibration bands for monomeric H_2O in dilute solution in carbon disulfide.

Borst, Buswell and Rodebush¹¹ made similar studies using carbon tetrachloride as the solvent. They maintained that there was no immediate correlation between the water vapor spectrum and the spectrum of the isolated water molecule in the non-polar solvent. However, in comparing the two absorption peaks that they found for the water molecule in solution, 3702 and 3611 cm^{-1} , to the fundamental frequencies of the stretching bands already determined for water in the vapor state, 3756 and 3654 cm^{-1} , they observed that, if they assigned the 3611 cm^{-1} band to ν_1 , then there was a shift of roughly the same magnitude from ν_1 and ν_3 in the vapor state to ν_1 and ν_3 in solution. Since the symmetrical stretching vibration had not previously been observed in the infrared, Borst et. al. made this assignment solely on the strength of this comparable frequency shift.

Fox and Martin¹² continued the study of water in dilute solutions in carbon tetrachloride. They likewise found two distinct bands which they assigned as the stretching vibrations ν_1 and ν_3 of 3705 and 3614 cm^{-1} respectively. This was in excellent agreement with the results of Borst et. al.

All of these investigators working with dilute solutions of water in non-polar solvents employed grating type spectrometers. Fox and Martin¹³ used an echelette grating in conjunction with a rocksalt prism spectrometer, thermopile and galvanometer system. With this instrumentation, it was possible to obtain the fine structure of lines

less than 2 cm^{-1} apart. This was a very laborious procedure however; it required setting up the instrument for a certain wavelength, inserting the solvent cell and taking a reading, inserting the sample cell and taking a reading, resetting the instrument for the next wavelength to be studied and repeating the entire procedure. The resultant spectrum for a given sample concentration was simply a series of points, one for each wavelength observed. Thus, the more wavelengths studied, the more points were obtained and therefore the more complete was the resulting spectrum.

Reviewing the work of all these investigators, it is found that by dissolving water in a non-polar solvent, the lattice interactions that restrict free rotation of the H_2O molecule are reduced. As a result, stretching vibration bands in the dilute solution comparable to those in the water vapor state have been determined. The symmetrical stretching vibration, ν_1 , which was a strong band in the Raman spectrum is, as expected, much weaker in the infrared than is the anti-symmetric stretching vibration band, ν_3 .

Also, the broad absorption band, characteristic of the hydroxyl vibration in associated compounds, was found to be absent in these dilute solutions. These observations all show that water in dilute solution in carbon tetrachloride (or carbon disulfide) is monomeric.

EXPERIMENTAL PROCEDURE

a. CORRECTION CURVE

A correction curve was prepared for the Perkin-Elmer double beam spectrophotometer Model #221 with NaCl prism-grating interchange. The curve was drawn from measurements of infrared spectra of various substances whose absorption bands have previously been directly and accurately determined by two Perkin-Elmer Model 12C spectrometers, one of which was converted to double-pass operation.¹⁴

All the spectra were obtained without removing the NaCl prism from the instrument. Each spectrum was run at least three times and the results were averaged. Sharp lines were reproducible to better than one-half small counter division (0.5 cm^{-1}), but the reproducibility of the broad peaks was not as good, therefore requiring more runs.

(1) Water and carbon dioxide bands ($3900-3560$, $1990-1360$ and $720-650 \text{ cm}^{-1}$) were obtained from atmospheric absorption. For these runs the instrument was placed in single beam operation. A test signal of 0.03 millivolts was employed.

(2) The carbon monoxide band ($2220-2040 \text{ cm}^{-1}$) was obtained using experimentally prepared carbon monoxide. One milliliter of formic acid and three milliliters of reagent grade thirty-six normal sulfuric acid were placed in a round-bottomed flask and heated. The evolved carbon monoxide gas was transferred through a vacuum system to a ten-centimeter-pathlength gas absorption cell that had previously been evacuated. The stopcock on the cell was secured with the entrapped carbon monoxide gas under fifteen centimeters pressure.

The windows of the gas absorption cell were potassium bromide. These windows were joined to the glass cell by a fifty-fifty (by weight) mixture of beeswax and rosin at a temperature of 120° C.

(3) The hydrogen chloride band (3060-2725 cm^{-1}) was obtained using HCl vapor in the ten-centimeter-path-length cell. One hundred fifty milliliters of reagent grade 12.1 normal hydrochloric acid were placed in a two-hundred-fifty milliliter glass-stoppered bottle and were well shaken. The gas absorption cell was evacuated and its stopcock secured. Its entrance tube was then inserted into the glass-stoppered bottle, the stopcock opened to draw the HCl vapor into the cell and then secured again. The sample was thus under atmospheric pressure throughout the runs.

(4) The hydrogen bromide band (2675-2410 cm^{-1}) was obtained using experimentally prepared HBr. Fifteen grams of potassium bromide was placed in a three-necked reaction flask. Reagent grade thirty-six normal sulfuric acid was added dropwise from a dropping funnel. The HBr formed was then transferred through the vacuum system to the ten-centimeter-pathlength gas absorption cell that had previously been evacuated. The HBr vapor was gathered in the cell under twenty-five centimeters pressure.

(5) The ammonia bands (3510-3170 and 1230-720 cm^{-1}) were obtained using experimentally prepared ammonia. Ten grams of ammonium chloride were placed in a three-necked reaction flask and reagent grade 50% sodium hydroxide solution was added dropwise from a dropping funnel. The NH_3 gas formed was transferred through the vacuum system and gathered in the gas absorption cell under twenty centimeters pressure.

(6) The methane bands (3170-2880 and 1360-1250 cm^{-1}) were obtained using experimentally prepared methane. Anhydrous sodium acetate was fused with sodium hydroxide in the presence of calcium oxide (lime) in a three-necked reaction flask and the evolved CH_4 gas was transferred through the vacuum system and gathered in the gas absorption cell under twenty centimeters pressure.

All chemicals used in these preparations were Baker's Analyzed (General Chemical Division of the Allied Chemical and Dye Corporation) except for the potassium bromide which was an E and A Tested Purity Reagent from the Fisher Scientific Company. Kel-F was utilized as stopcock grease and on all ground glass fittings of the vacuum system.

In obtaining the various spectra, a drum speed of 0.49 cm^{-1} / sec, a slit program of 920, a gain of 6.0, an attenuator speed of 11:00 and a scale of 5 wave numbers per centimeter of chart paper were normally employed. Variations in drum speed, gain and slit program were used in an attempt to obtain better reproducibility of the broad peaks.

The spectra obtained were compared with calibration traces previously determined from the Perkin-Elmer Model 12Cs. The pressure under which a sample was collected was determined solely to allow direct comparison with these calibration traces. Discrepancies between the experimentally determined spectra and the calibration traces were tabulated for each absorption band of each sample studied. From the three or more runs of each sample, the discrepancies for a given peak were averaged, and this average value plotted versus the wave number of the absorption band as a correction factor (e.g., that amount necessary to be added or subtracted to the absorption band wave number determined by the instrument to produce the correct wave number of the band.) In this

manner, a smooth correction curve (Figure 1) was plotted over the infrared region ($3900-650 \text{ cm}^{-1}$).

b. INFRARED ABSORPTION OF WATER DISSOLVED IN CARBON TETRACHLORIDE

(1) Description of Apparatus - The infrared spectra of water dissolved in carbon tetrachloride were obtained utilizing the Perkin-Elmer double beam spectrophotometer Model #221 with NaCl prism-grating interchange. Two identical liquid absorption cells were specially designed for use in these experiments. The body of each cell was a stainless steel cylinder, five centimeters in length and 3.81 centimeters in internal diameter. The end plates were silver chloride crystals, 6.35 millimeters thick. Silver chloride windows were chosen since their absorption in the infrared region is negligible and since they would not react with the contained liquid samples. Fluorocarbon rubber (Viton-A) O-rings joined the silver chloride windows to the cylinder. Completing the cell were aluminum washers separated from the outer face of the windows by neoprene gaskets. These gaskets were necessary to prevent any reaction between the aluminum and the silver chloride. Each washer was fitted with four one-eighth diameter holes through which threaded rods were placed. Each cell was then made leak-proof by tightening down nuts on both ends of the threaded rods. Figure 2 gives a detailed description of this five-centimeter-path-length liquid absorption cell.

A hole of one-quarter inch internal diameter was drilled in the side of each cylinder and provided with a threaded inlet tube, also of stainless steel, which was tin soldered to the exterior of the cylinder. A stainless steel cap fitted with a teflon gasket was

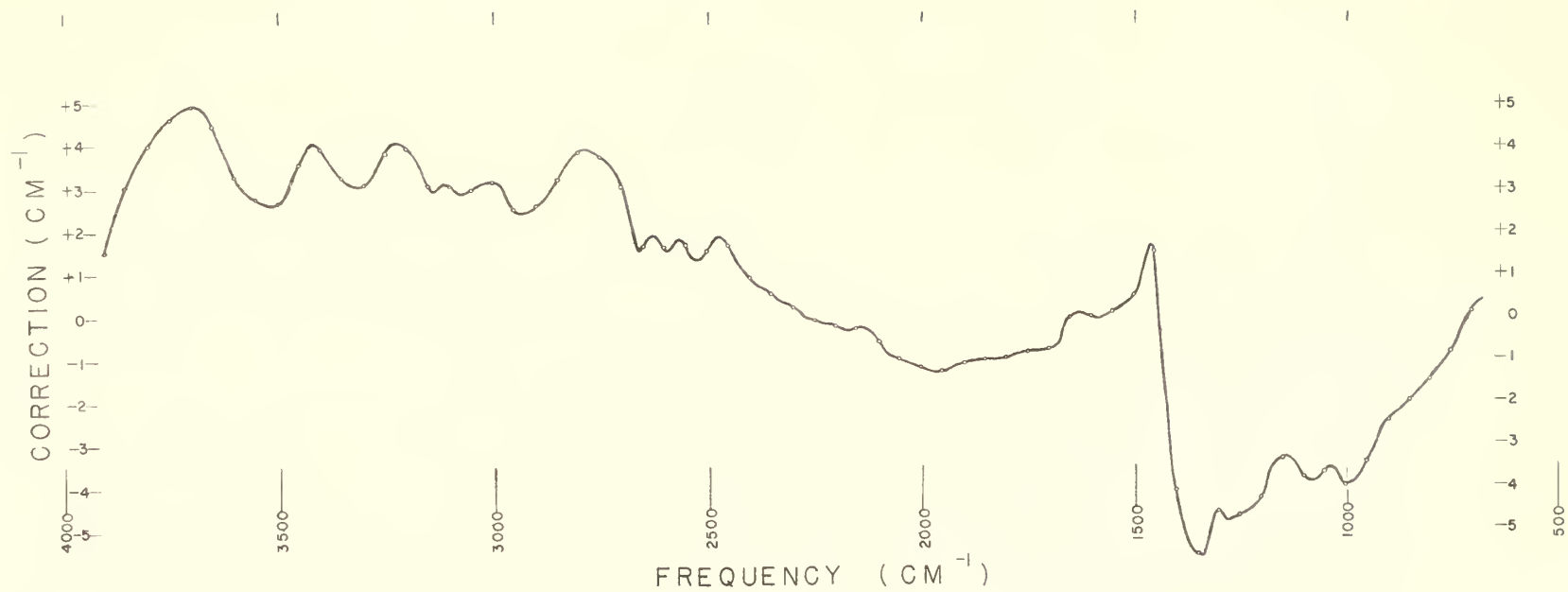
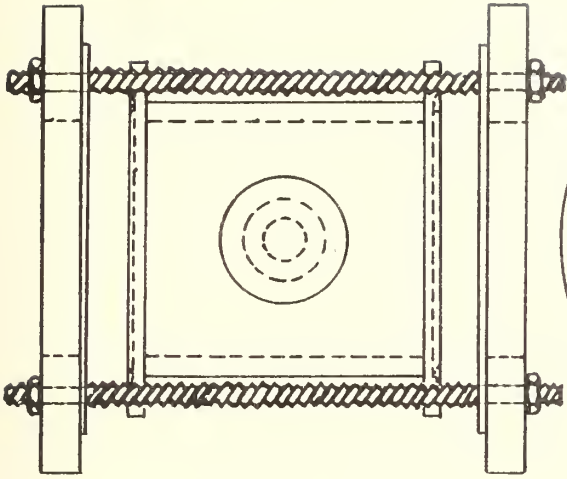
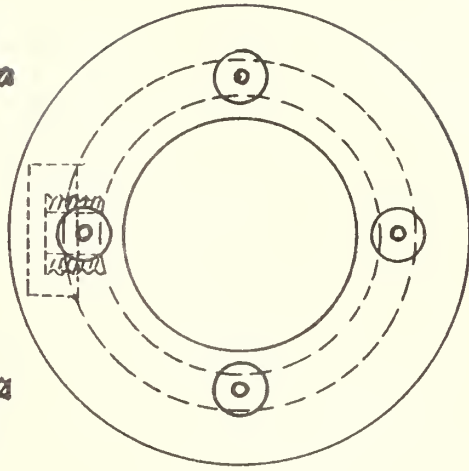

Figure 1. Correction curve for the Perkin-Elmer double beam spectrophotometer Model 221 with NaCl prism-grating interchange.

TOP



FRONT



SIDE

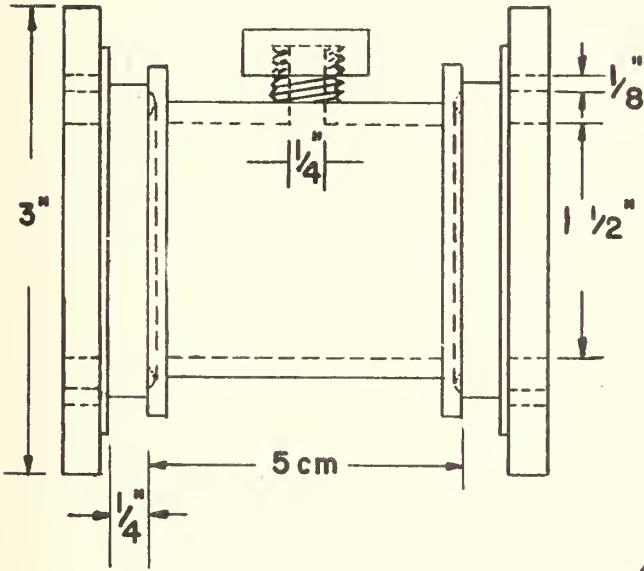
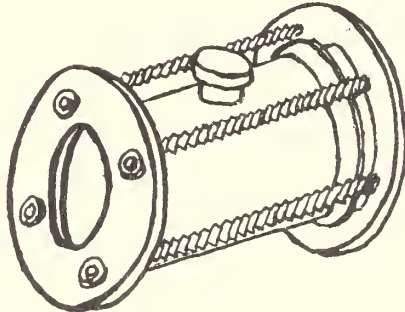

FIGURE 2

5 CENTIMETER
PATHLENGTH
ABSORPTION
CELL



threaded onto the inlet tube.

One five-centimeter-pathlength cell was placed in the reference beam of the spectrophotometer. This cell was completely filled with dry carbon tetrachloride (e.g., no water present in the sample). The other cell was placed in the sample beam and was completely filled with carbon tetrachloride to which various minute portions of water were added.

In obtaining the various spectra, drum speeds of 2.5 and 1.3 $\text{cm}^{-1}/\text{sec.}$, a slit program of 927, a gain of 5.0, an attenuator speed of 11:00 and a scale of 12.5 wave numbers per centimeter of chart paper were employed.

(2) Preparation of the Sample - Initially, infrared spectra of reagent grade carbon tetrachloride were taken, both in the five-centimeter-pathlength cell just described and in a five-millimeter IR-tran cell, to determine its water content, if any. Pronounced absorption peaks at 3705 and 3613 cm^{-1} (the stretching frequencies of the H_2O molecule dissolved in carbon tetrachloride) gave indication of the presence of water in the reagent grade carbon tetrachloride.

From these same runs it was determined that it would be highly improbable to utilize carbon tetrachloride as a solvent for investigation of the bending frequency of the H_2O molecule since even in the short five-millimeter-pathlength cell the reagent grade carbon tetrachloride absorbed completely in this region (1700-1550 cm^{-1}).

To investigate the stretching frequencies of water dissolved in carbon tetrachloride, it was first necessary to devise a method to dry the solvent. Clifford,¹⁵ in treating the quantitative aspect of water dissolved in carbon tetrachloride, bubbled air dried with calcium chloride into the saturated carbon tetrachloride and absorbed the

moisture carried off by the air in a calcium chloride filled absorption tube. Fox and Martin¹² substituted phosphorus pentoxide for the calcium chloride drying agent and used an air bubbler incorporating a sintered glass filter. Thus by passing dry air through the saturated solvent for a given time and by determining the weight of the absorption tube both before and after the air passage, the amount of water removed from the carbon tetrachloride was calculated from this weight difference.

In the present work, since the quantitative aspect is of minor importance, it was unnecessary to employ the absorption tube to collect the moisture removed from the carbon tetrachloride.

A method similar to that of Clifford was attempted first. Air was passed through a drying tower packed with calcium chloride and then through a bubbler incorporating a sintered glass filter. The filter was immersed in the reagent grade carbon tetrachloride sample which was placed in a two hundred fifty milliliter separatory funnel equipped with a teflon stopcock. The "dried" sample was transferred directly from the separatory funnel to the five-centimeter-pathlength cell without exposure to the atmosphere. Various amounts of carbon tetrachloride (fifty, one hundred and two hundred milliliter samples) and various drying times (five minutes to three hours) were tried but, although the absorption peaks diminished somewhat, in no instance was all the water removed from the solvent.

Then, a distillation of the reagent grade carbon tetrachloride was attempted. A vertical distillation tower packed with glass helices was employed, and a middle cut of the distilled carbon tetrachloride was examined. Still the pronounced absorption peaks were present.

Next, twenty grams of anhydrous sodium sulfite were added to two hundred milliliters of reagent grade carbon tetrachloride in a glass-stoppered bottle. This mixture was placed on the electric shaking machine for one hour and then allowed to stand for one-half hour so that the sodium sulfite had sufficient time to settle to the bottom of the bottle. The carbon tetrachloride was then transferred to the five-centimeter-pathlength cell by means of a fifty milliliter pipette. The resulting spectrum taken of the sample showed hardly any diminution of the H_2O absorption peaks. Similar runs were made employing fifty and one hundred grams of sodium sulfite and increasing the shaking time to three hours. Still the water remained.

Anhydrous sodium sulfate was the next drying agent tried. The same amounts of drying agent and the same shaking times were employed in the sodium sulfate runs as were used with sodium sulfite. Likewise the results were similar, as in every instance some water remained in the solvent.

Phosphorus pentoxide, the drying agent employed successfully by Fox and Martin, was the third drying agent used in the present work. After trials with various amounts of P_2O_5 and of various shaking times it was discovered that adding thirty grams of the drying agent to two hundred milliliters of carbon tetrachloride in a glass-stoppered bottle and shaking the mixture for four hours effectively removed all the water from the reagent grade carbon tetrachloride.

When the bottle was taken off the shaker it was allowed to stand for one-half hour so that the phosphorus pentoxide would settle out. The aluminum foil and masking tape with which the glass stopper was secured to the bottle during shaking was then cut away and the glass stopper was

loosened. When the stopper was removed, a fifty milliliter pipette was quickly inserted into the carbon tetrachloride layer and the dry solvent was transferred to the five-centimeter-pathlength cell. The fifty milliliter pipette was equipped with a suction bulb with which to draw the sample into the pipette and to release it into the absorption cell. Actually since the volume of the cell was 58.9 cubic centimeters (experimentally determined from weight difference of empty cell and cell filled with water), it was necessary to pipette twice. Between the two transfers the cap was placed on the cell and the glass stopper was placed on the bottle to minimize any effect of atmospheric absorption.

Both five-centimeter-pathlength cells were filled in this manner. The infrared spectrum of each sample was obtained utilizing a cardboard shutter in the reference beam in order to provide an expanded percent transmission scale. Both samples were perfectly dry.

The next step was to add various amounts of water to one of the cells and to examine the change in the infrared spectrum of the sample. Since water is only very slightly soluble in carbon tetrachloride, 0.0084% at 20°C¹⁶ and 0.013% at 28.5°C,¹⁵ micropipettes were used to add the minute portions of freshly distilled water to the dry solvent.

The distilled water was placed in a twenty five milliliter volumetric flask. A five lambda micropipette, joined to a hypodermic syringe by a single-holed 00 rubber stopper, was inserted into the water, and five lambda (0.005 cc) of the liquid were transferred to the five-centimeter-pathlength cell containing the dry carbon tetrachloride. The cap was replaced on the cell as tightly as possible and the cell was shaken for approximately five minutes and then allowed to

remain at room temperature for at least four hours. It was determined in trial runs that this four hour waiting period was necessary to ensure consistent results on the various spectra taken for a given amount of water in the sample. When a run was made immediately upon shaking and another two hours later, the latter spectrum invariably exhibited more pronounced absorption peaks. This apparent increase in the amount of water in solution is due to the time involved for the sample of water to dissolve in the carbon tetrachloride (e.g., immediately upon shaking very little of the water has gone into solution whereas after three hours presumably all the water has dissolved.) A run made four hours after shaking and one made a day later gave identical results.

This same procedure was followed for water samples of five, ten and fifteen lambda. Also runs of one, two and three lambda were attempted by interpolating along the five lambda pipette. The accuracy of this interpolation is questionable especially due to the tapered bore of the micropipette. Reference to Figures 3 and 5 shows the increasing intensity of the absorption peaks with the increasing amounts of water in the dry carbon tetrachloride. Curve (a) of Figure 3 is the spectrum of dry carbon tetrachloride. Curves (b), (c), (d) and (e) correspond to two, five, ten and fifteen lambda of water dissolved in the solvent.

For the amount of carbon tetrachloride in the five-centimeter-pathlength absorption cell, at a temperature of 28.5° C., fifteen lambda of water corresponds to 0.016 grams of water per 100 grams of carbon tetrachloride. This exceeds saturation as determined by Clifford¹⁵ by twenty-three percent. Since the objective of the present work was not primarily quantitative, the various concentrations are

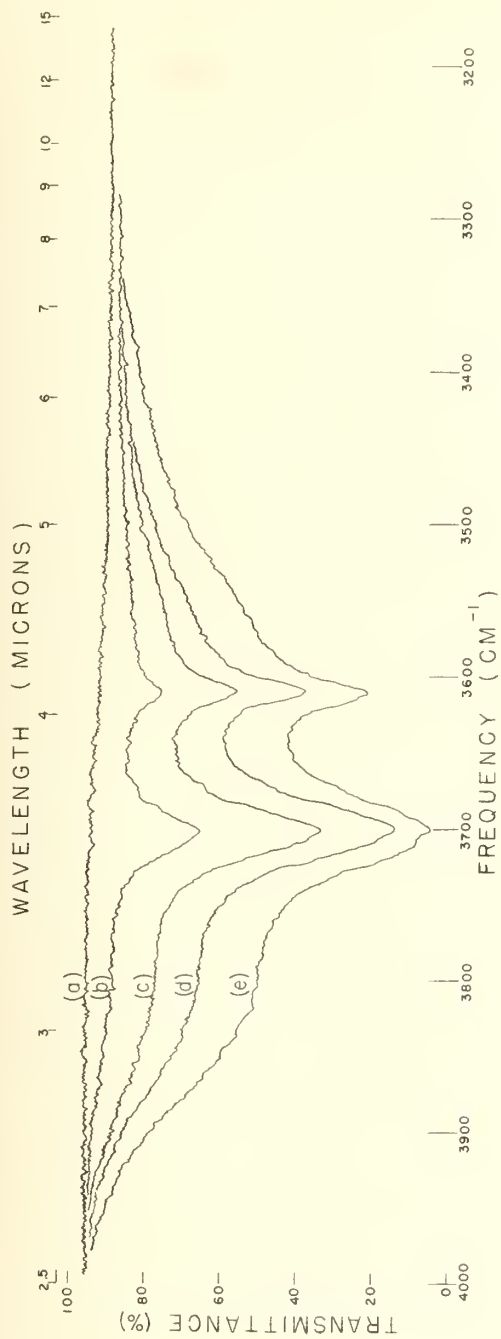

Figure 3. Absorption of dilute solutions of H_2O in carbon tetrachloride; (a) dry CCl_4 (b) $\sim 13\%$ (c) $\sim 33\%$ (d) $\sim 67\%$ (e) $\sim 100\%$ saturated at $28.7^\circ C$. (double beam operation; gain 5.0, resolution 927)

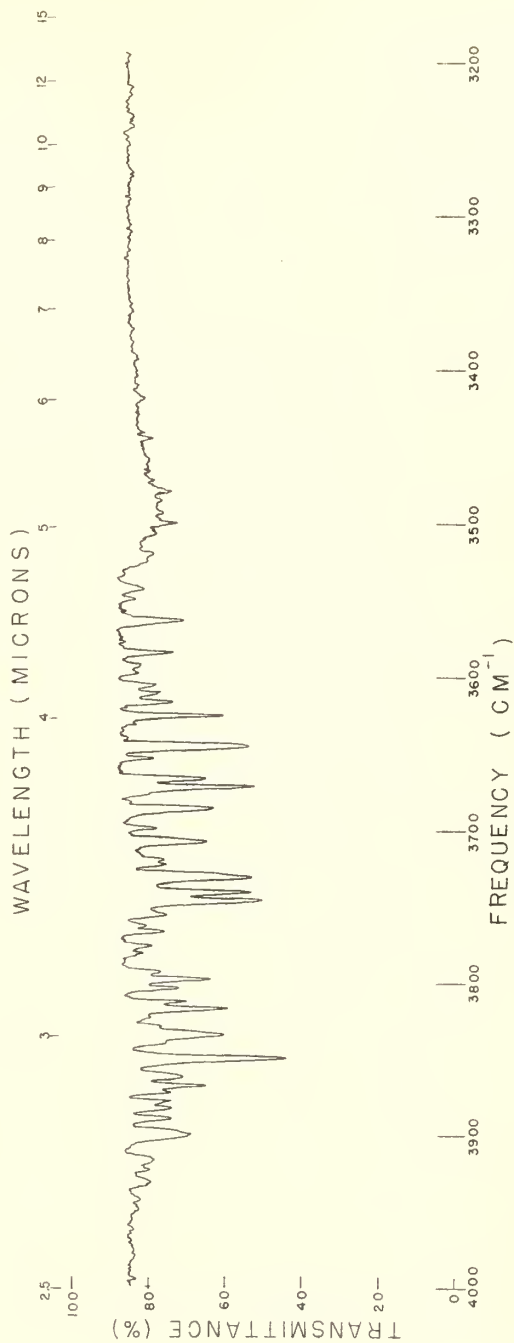

Figure 4. Absorption of water vapor in the region $3900 - 3200\text{ cm}^{-1}$. (single beam operation; gain 7.5, resolution 600, test signal 0.03 millivolts)

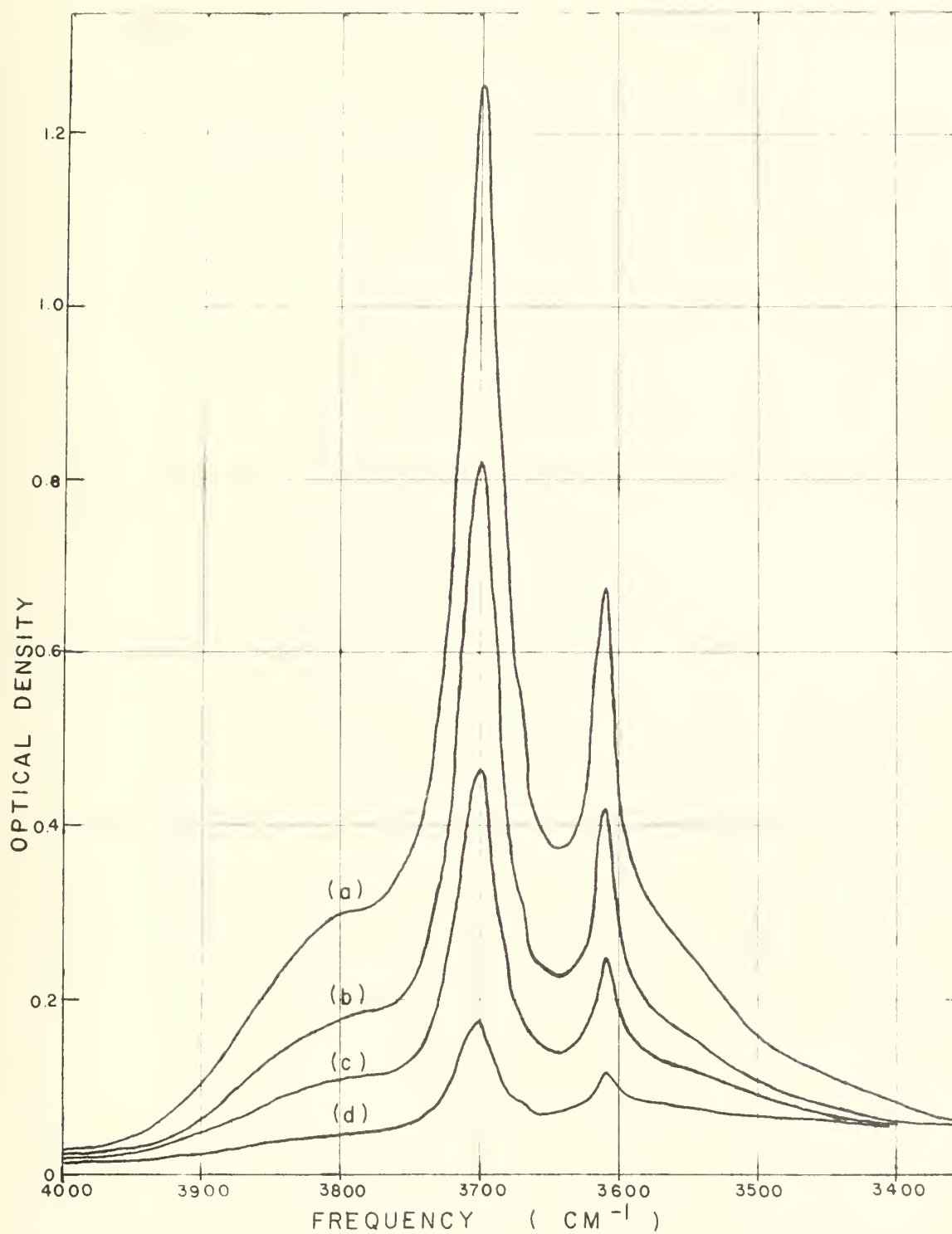

Figure 5. Absorption of water dissolved in carbon tetrachloride after correcting for the absorption of the latter; (a) \sim 100% (b) \sim 67% (c) \sim 33% (d) \sim 13% saturated at 28.5^o C.

listed in Figures 3 and 5 as approximate values.

A further explanation of the apparent greater solubility of water in carbon tetrachloride determined in this work from the values obtained by previous authors is the possibility that some of the phosphorus pentoxide drying agent was introduced into the absorption cell along with the dry solvent. Thus a portion of each water sample added could have been absorbed by the drying agent in the absorption cell, resulting in a greater amount of water necessary to be added to achieve saturation.

Figure 3 is the spectrum actually obtained for a given concentration from the spectrophotometer. Figure 5 is simply another representation of the same data, where optical density instead of percent absorption is utilized as the ordinate. Optical density has already been defined as $\log I_0/I$ where I_0 is the radiation transmitted by the cell containing the dry solvent and I is the amount transmitted by the sample cell.

At least once a day throughout these experiments, the cell containing the dry carbon tetrachloride was placed in the sample beam, the cardboard shutter was placed in the reference beam and a spectrum taken to determine whether or not the sample had absorbed any water. In all cases, the results were negative.

In order to compare the absorption of water in carbon tetrachloride with water as vapor, the infrared spectrum of water vapor was obtained over the same region ($3900-3200 \text{ cm}^{-1}$) by employing the instrument in single beam operation and by using a test signal of 0.03 millivolts. (Figure 4) The individual peaks of the vapor spectrum compare well with the measurements of Plyler and Sleator.⁶

c. INFRARED ABSORPTION OF WATER DISSOLVED IN CARBON DISULFIDE

The same apparatus was used for the carbon disulfide phase of the experiments as was employed for the carbon tetrachloride phase. The procedure followed was likewise the same with two exceptions.

First, it was impossible to completely rid the reagent grade carbon disulfide of all the water present. The air bubbler technique, sodium sulfite and sodium sulfate drying agents were tried and all failed. Finally two hundred fifty grams of phosphorus pentoxide were added to five hundred milliliters of carbon disulfide in a glass-stoppered bottle and shaken for five hours. It was necessary to use such large amounts because, after the phosphorus pentoxide settled to the bottom, it was possible to pipette only about seventy five milliliters of the carbon disulfide into the absorption cell without drawing some of the phosphorus pentoxide into the pipette. With lesser amounts of the P_2O_5 it was impossible to dry sufficiently the five hundred milliliters of solvent; yet if both the amounts of drying agent and solvent were reduced, such a small layer of solvent formed on top of the P_2O_5 that it was extremely difficult to transfer the solvent without also pipetting some of the drying agent.

An unexplained phenomenon in the carbon disulfide experiments was the appearance of a pink color that enveloped the phosphorus pentoxide that settled to the bottom of the shaking bottle. The development of this color was of a gradual nature, starting in the fourth hour of shaking. It was proposed that a reaction was occurring between the phosphorus pentoxide and the water in the carbon disulfide producing some phosphoric acid. However since the infrared spectra of the reagent grade carbon disulfide and the carbon disulfide "dried" by air bubbling,

sodium sulfite and sodium sulfate produced the same absorption peaks as the sample dried with the phosphorus pentoxide, it seems that the reaction that took place did not interfere with the spectrum in the infrared region. The spectrum of this sample of two hundred fifty grams of P_2O_5 and five hundred milliliters of carbon disulfide showed just the slightest trace of an absorption peak at 3695 cm^{-1} .

The second exception to the carbon tetrachloride runs was the solubility of water in carbon disulfide, 0.10% at 25° C .¹⁰ This was approximately ten times the solubility of water in carbon tetrachloride, thereby allowing larger portions of water to be utilized. Five, ten, fifteen, twenty, twenty-five, thirty-five, fifty and seventy-five lambda samples were examined. Figure 6 exhibits the increasing intensities of the absorption peaks with increasing amounts of water. Curve (a) of this figure corresponds to seventy-five lambda of water dissolved in carbon disulfide. Curves (b), (c) and (d) correspond to thirty-five, fifteen and ten lambda of water respectively.

Comparison of Figures 5 and 6 shows that the two stretching frequencies of the H_2O molecule in carbon tetrachloride of 3705 and 3613 cm^{-1} are displaced to 3695 and 3603 cm^{-1} when carbon disulfide is the solvent.

d. INVESTIGATION OF THE BENDING REGION

The improbability of using either reagent grade carbon tetrachloride or carbon disulfide as a solvent in the investigation of the bending region of the H_2O molecule, even with a cell having so short a pathlength as five millimeters, was previously determined. Therefore a shorter pathlength cell was used with the dry solvents.

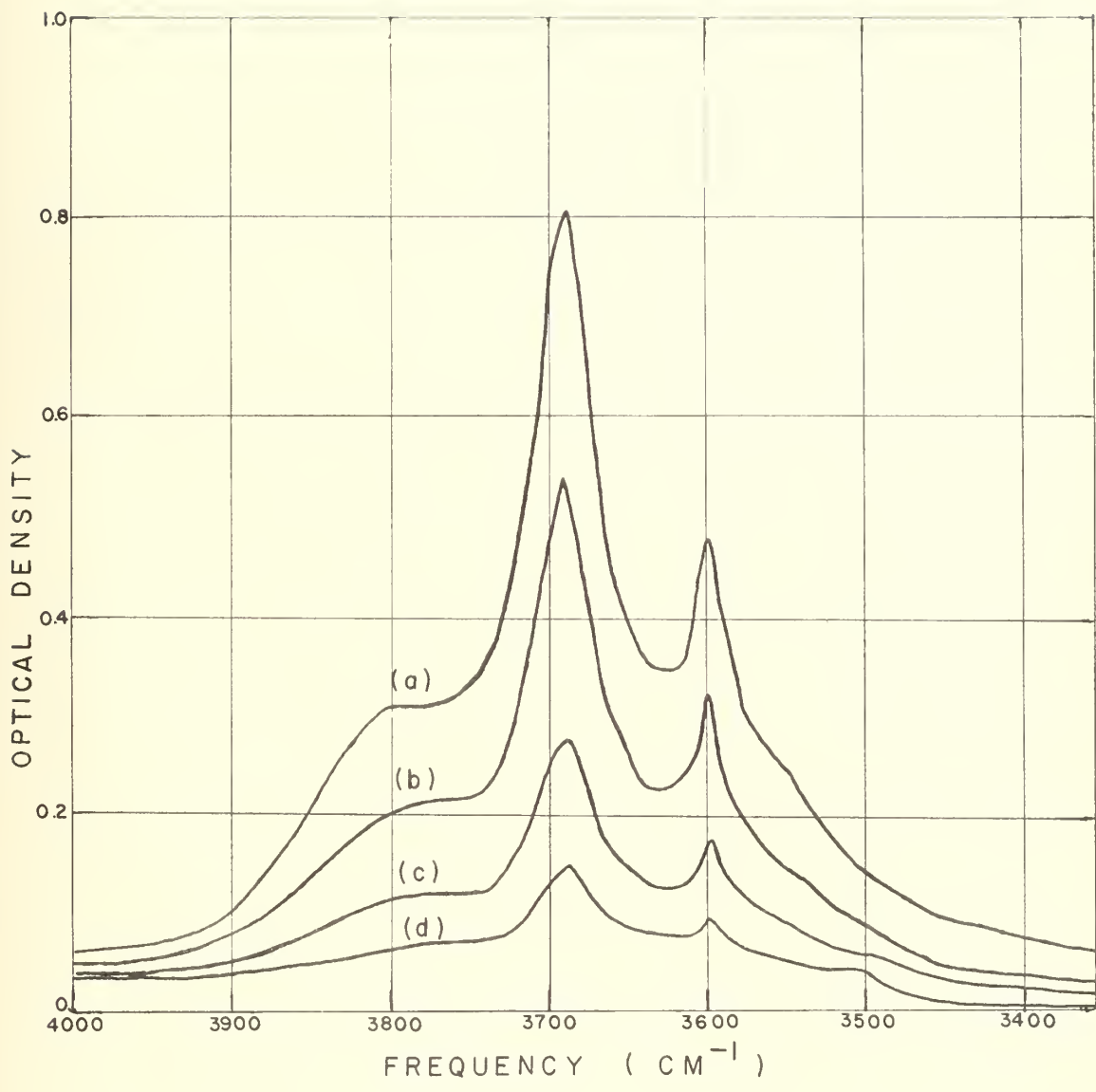

Figure 6. Absorption of water dissolved in carbon disulfide after correcting for the absorption of the latter; (a) $\sim 100\%$ (b) $\sim 50\%$ (c) $\sim 20\%$ (d) $\sim 13\%$ saturated at 28.5° C.

Experiments were conducted using (a) a one-millimeter-pathlength cell filled with dry carbon disulfide in the sample beam, and the cardboard shutter in the reference beam, and (b) the same cell filled with saturated carbon disulfide in the sample beam and the shutter in the reference beam. From these runs it was found that the carbon disulfide totally absorbs in the bending region even at this very short pathlength. Thus it is unusable as a solvent in this region.

The same procedure was followed for carbon tetrachloride. Absorption was less than ten percent for both the dry and the saturated carbon tetrachloride over the range 3900-1750 cm^{-1} except for a characteristic carbon tetrachloride band at 2300 cm^{-1} . At 1750 cm^{-1} a gradual increase in absorption occurred, approaching total absorption at 1580 cm^{-1} . This indicated a slight possibility of examining the bending frequency with carbon tetrachloride as the solvent.

The saturated carbon tetrachloride in the one-millimeter-pathlength cell was placed in the sample beam and a variable-pathlength cell was filled with dry carbon tetrachloride and was placed in the reference beam. The instrument gain was increased to 8.5, the slit program was varied and a vertical expansion of 10X was employed in an attempt to tune the spectrophotometer to its peak performance level.

However, due to the relative weakness of the bending frequency as compared to the stretching bands, the atmospheric absorption in the bending region and the fact that this region was situated on the edge of total carbon tetrachloride absorption, it was impossible to locate the bending vibration band of the isolated H_2O molecule.

RESULTS AND DISCUSSION

The H_2O molecule is a planar asymmetric top molecule. It has a plane of symmetry σ , and, by reflection at this plane the O atom on one side is transformed into the O atom on the other side. Also, the line bisecting the O-H-O angle is a two-fold axis. In other words, a rotation of 180° around this axis transforms the molecule into itself. The two O-H distances are equal.¹⁷

For H_2O the two O-H stretching frequencies of nearly the same magnitude, one symmetric and one antisymmetric, and a bending frequency of much smaller magnitude are expected. These three modes of vibration are depicted in Figure 7.

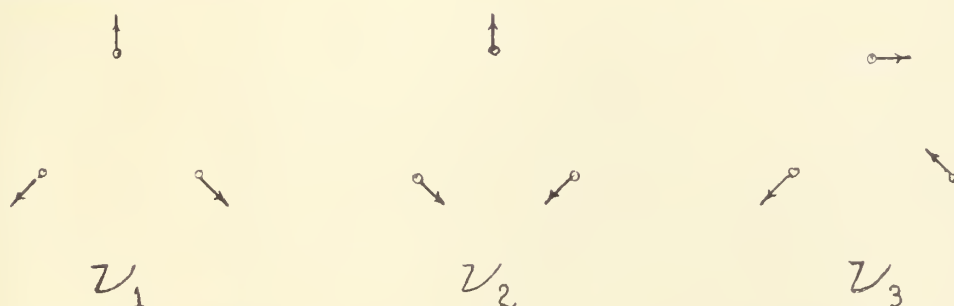

Figure 7. Modes of vibration of the isolated water molecule

For dilute solutions of water in carbon tetrachloride two absorption bands were found at 3705 and 3613 cm^{-1} . With carbon disulfide as the solvent, the observed peaks were 3695 and 3603 cm^{-1} . The values obtained for the carbon tetrachloride phase were in excellent agreement with the values determined by Fox and Martin¹² and by Borst et. al.¹¹ The absorption bands found for the carbon disulfide phase also agreed with the values of Fox and Martin but they did not compare favorably with the values of Kinsey and Ellis for this solvent.

The two absorption bands determined with each solvent have been assigned as ν_3 and ν_1 respectively by these previous workers. This is a reasonable assignment since the percentage frequency shifts of ν_3 and ν_1 from their positions in the vapor spectrum are

practically the same. This is to be expected since any alteration in the force constants of the O-H bond by the solvent molecules will affect the frequencies equally to a first approximation.

The frequency shift of a hydroxyl group in a solvent is a measure of the interaction between the solute and solvent molecules. Thus, another justification for the assignment of these absorption bands can be found in the comparison of the results obtained with each solvent. For water in dilute solution in carbon tetrachloride, the shift of ν_3 and ν_1 from their vapor frequencies is to 3705 and 3613 cm^{-1} respectively; however the shift is to 3695 and 3603 cm^{-1} for water in dilute solution in carbon disulfide. Therefore the shift of both stretching vibrations is displaced ten wave numbers further in the latter solvent, inferring that the carbon disulfide molecules engage in a stronger interaction with the isolated water molecules than do the molecules of carbon tetrachloride. This is exemplified in (1) the much greater solubility of water in carbon disulfide than in carbon tetrachloride and (2) the greater polarizability of carbon disulfide.

In addition to the two stretching vibration bands observed with each solvent, it was possible, by graphical separation of the absorption spectrum into its components, to observe two other broad bands of lesser intensity. One of these, with its center at about 3804 cm^{-1} was also reported by Fox and Martin in their work with dilute solutions of water in carbon tetrachloride. It was proposed by these authors that this band might be the envelope of the rotation lines in this region since it appears to follow the envelope of the rotation lines in the vapor spectrum over the same frequency range.

The second broad band found in the carbon tetrachloride phase had its center at about 3540 cm^{-1} . This band has not been reported by

previous investigators, probably because their work covered only the region 3900-3500 cm^{-1} . In the present work the study was continued to 3200 cm^{-1} . In the carbon disulfide phase the two broad bands were found with centers at 3796 and 3547 cm^{-1} .

Figure 8 shows the graphical separation of the spectrum of water in dilute solution in carbon tetrachloride. The sample with ten lambda of water in about fifty nine milliliters of dry carbon tetrachloride (corresponding to approximately 67% of saturation) is depicted in this figure. The area of each separate band is roughly equal to $1.4fk_{\text{max}}$.¹³ K_{max} is the maximum value of the optical density for a given band, divided by the concentration in moles per liter and the length of the absorption cell (in this case five centimeters). f is the half-width of the band (in cm^{-1}) measured at an ordinate value corresponding to $\frac{1}{2} K_{\text{max}}$. The results for the other carbon tetrachloride samples and the results of the carbon disulfide runs were similar and were not included as separate figures.

These findings support the validity of the assignments by Fox and Martin of ν_1 and ν_3 to the sharp intense bands and their explanation that the higher frequency broad band is the envelope of the rotation lines. However it is still necessary to try to explain the existence of the broad band having its maximum intensity at about 3540 cm^{-1} .

Again referring to the vapor spectrum of water (Figure 4) it might be proposed that this band, too, is the envelope of the rotation lines in this region. First though, some other possibilities should be investigated.

One such possibility considered was that this band might be the first overtone of the fundamental bending vibration of the isolated water molecule. As yet this bending frequency, ν_2 , has not been observed for dilute solutions of water in non-polar solvents. It has been observed however in the vapor spectrum at 1595 cm^{-1} ,⁶ in liquid water (20° C) at 1646 cm^{-1} ¹² and in ice at 1620 cm^{-1} .¹⁸ Thus it is expected that the

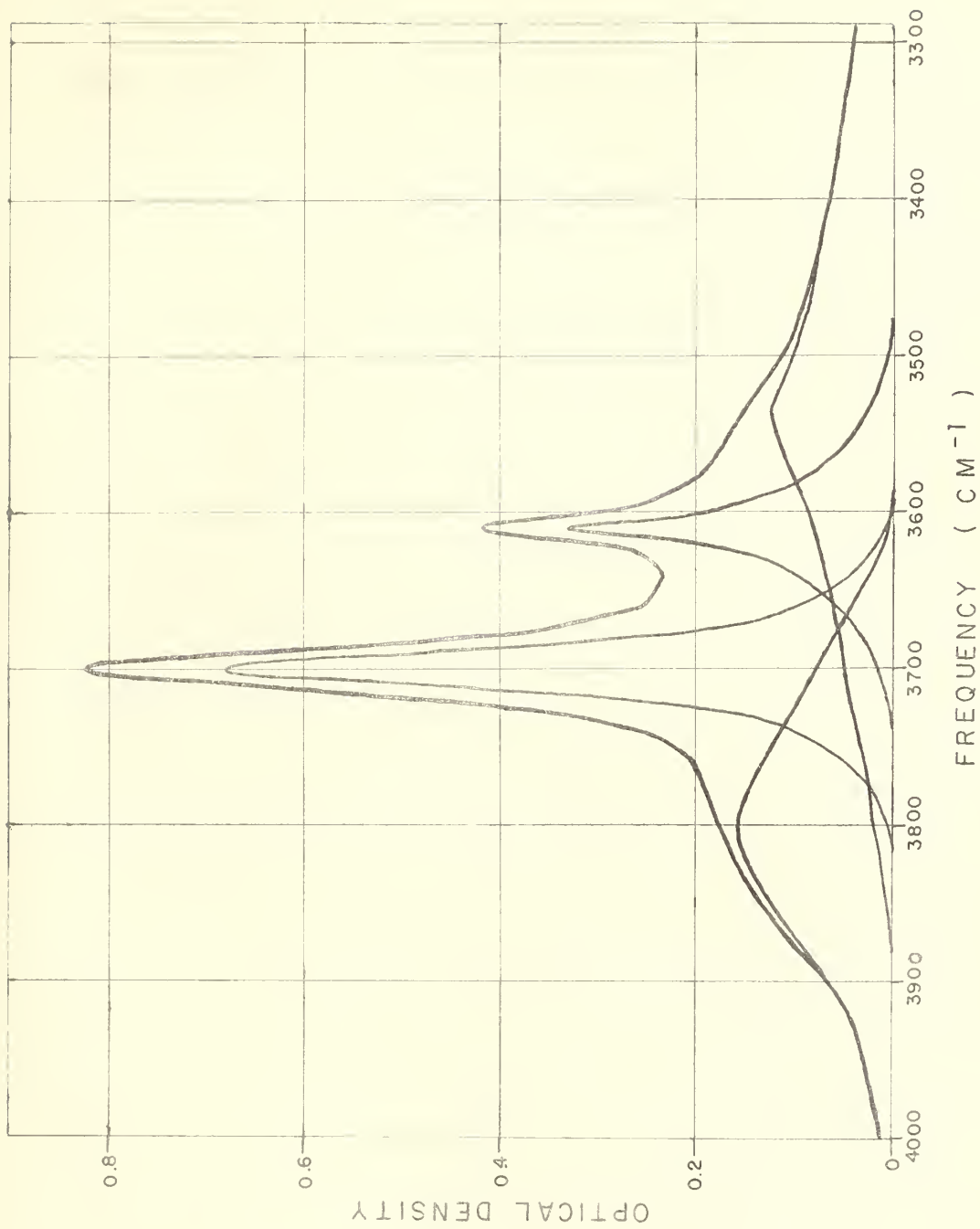

Figure 8. Graphical separation of the absorption bands of water in carbon tetrachloride.

corresponding band of the isolated H_2O molecule in the non-polar solvent should be in the neighborhood of these values.

Using these frequencies, the calculated value for the first overtone frequency, $2\nu_2$, should be approximately 3300 cm^{-1} . This would place it some 240 cm^{-1} on the low frequency side of the observed band being considered as this first excited state of the bending vibration.

The next proposal considered was the chance of Fermi resonance occurring within the isolated water molecule. Fermi resonance might be expected to occur within a molecule when a fundamental vibration (ν_1 in this case) has a frequency in the same region as the first overtone of another vibration ($2\nu_2$ for the water molecule).¹⁹ Since these two vibrational levels have the same symmetry (e.g. they are both symmetric vibrations) and since they have nearly the same energy, it is possible for a perturbation of these energy levels to occur. Without the resonance, the fundamental ν_1 would have a much greater intensity than the overtone, $2\nu_2$. But if the interaction (resonance) is taken into account, the intensity of the two bands will be more nearly alike. In other words, $2\nu_2$ "borrows" intensity from ν_1 so that its intensity may become of the same magnitude as that of the fundamental. If the resonance were complete the two would have the same intensity. However in Figure 8 it is shown that ν_1 is still 2.5 times as large as the proposed $2\nu_2$. This would infer that Fermi resonance, if occurring at all, certainly is by no means complete.

The proposal of Fermi resonance has the same drawback as has the suggestion that the broad band at 3540 cm^{-1} is the first overtone of the bending vibration. It assumes that this bending vibration of the isolated H_2O molecule is located at about 1770 cm^{-1} (130 cm^{-1} greater than has been observed for water in any state).

Next, a different type of perturbation was proposed to occur in the H_2O molecule. Since the two stretching vibrations ν_1 and ν_3 have a similar magnitude, there is the chance that they might perturb each other and cause an "accidental degeneracy" similar to that suggested for an interaction between ν_3 and $2\nu_2$. However Darling and Dennison²⁰ show that this is impossible because ν_1 and ν_3 are of different species (e.g. ν_1 is a symmetric vibration whereas ν_3 is antisymmetric.)

Thus it appears that this fourth observed band cannot be satisfactorily explained in the usual manner as overtone or combination frequencies of the three fundamental vibrations that have been assigned. But there is still another possibility. A band has been discovered in the spectrum of liquid water and of ice at about 2130 cm^{-1} ,²¹ although it is absent in the water vapor spectrum. Further, a band has been found at about 510 cm^{-1} in liquid water²² (590 cm^{-1} in ice²³) which has been called the frequency of hindered rotation.

As has been previously discussed, the liquid state is a quasi-crystalline state where the molecules undergo rotational oscillations and, only under certain conditions, engage in free rotation. This "hindered rotation" state which is composed of energy levels intermediate between free rotation and rotational oscillations might even be expected to exist in the dilute solution of water in the non-polar solvent. Ellis and Sorge²¹, though suspecting the 2130 cm^{-1} band in liquid water to be a combination of the fundamental bending frequency and this hindered rotation frequency, designated this peak as a fourth fundamental.

Employing the band at 2130 cm^{-1} as a fundamental, it might be possible to explain the broad band at 3540 cm^{-1} as a combination of the bending vibration and this new band at 2130 cm^{-1} . It appears though that the

calculated value of this proposed combination band are as far removed from the observed peak on the high frequency side (e.g. $1595 + 2130 = 3725 \text{ cm}^{-1}$) as were the previous attempts on the low frequency side.

Further, the validity of this proposal is questionable since its basis was the hindered rotation frequency which has been observed only in liquid water and in ice but not in dilute solutions of water in a non-polar solvent. Thus the combinations suggested, while maybe acceptable for liquid water or ice, are probably inapplicable when applied to the solution.

In summary, it was shown that water has been thoroughly studied in its associated or polymeric form in the solid, liquid and vapor states. However further investigation is desired of the monomeric form of water (e.g. the isolated H_2O molecule that was studied in the present work by infrared examination of water in dilute solution in non-polar solvents). For, although numerous workers have concurred that the two sharp bands present in the solution are the two fundamental stretching vibrations of the isolated H_2O molecule, as yet the only explanation given for the observed broad peaks of lesser intensity is that they might possibly be the envelope of the rotation lines of water in this region. Also, to date it has been impossible to locate the bending vibration of the isolated H_2O molecule since the non-polar solvents investigated in which water is at all soluble absorb completely in the bending region.

Complete information regarding the isolated H_2O molecule, including satisfactory explanations for the observed broad bands of the dilute solution of water in non-polar solvents, is necessarily dependent on the discovery of the bending frequency of the isolated H_2O molecule. Thus it

is recommended that further studies be conducted employing all possible non-polar solvents and utilizing the shortest possible pathlength cells in order to locate this frequency.

BIBLIOGRAPHY

1. Errera, J. and Mollet, P., Nature, Lond., 138, 882 (1936)
2. Davies, M. M. and Sutherland, G. B. B. M., Nature, Lond., 141, 372 (1938)
3. Davies, M. M. and Sutherland, G. B. B. M., J. Chem. Phys., 6, 755 (1938)
4. Buswell, A. M., Dietz, V. and Rodebush, W. H., J. Chem. Phys., 5, 84 (1937)
5. Fox, J. J. and Martin, A. E., Proc. Roy. Soc., A 162, 419 (1937)
6. Plyler, E. K. and Sleator, W. W., Phys. Rev., 37, 1493 (1931)
7. Bender, D., Phys. Rev., 47, 252 (1935)
8. Johnston, H. L. and Walker, M. K., Phys. Rev., 39, 535 (1932)
9. Debye, P., Physik Z., 36, 100 (1935)
10. Kinsey, E. L. and Ellis, J. W., Phys. Rev., 51, 1074 (1937)
11. Borst, L. B., Buswell, A. M. and Rodebush, W. H., J. Chem. Phys., 6, 61 (1938)
12. Fox, J. J. and Martin, A. E., Proc. Roy. Soc., A 174, 234 (1940)
13. Fox, J. J. and Martin, A. E., Proc. Roy. Soc., A 167, 257 (1938)
14. Downie, A. R., Magoon, M. C., Purcell, T. and Crawford, B., J. Opt. Soc. Amer., 43, 941 (1953)
15. Clifford, C. W., Ind. Eng. Chem., 13, 631 (1931)
16. Rosenbaum, C. K. and Walton, J. H., J. Amer. Chem. Soc., 52, 3568 (1930)
17. Herzberg, G., "Molecular Spectra and Molecular Structure" Vol. II, van Nostrand, 1954, p. 2
18. Hornig, D. F., White, H. F. and Reding, F. P., Spectrochim. Acta., 12, 338 (1958)
19. Herzberg, G., "Molecular Spectra and Molecular Structure" Vol. II, van Nostrand, 1954, p. 265
20. Darling, B. T. and Dennison, D. M., Phys. Rev., 57, 128 (1940)

21. Ellis, J. W. and Sorge, B. W., J. Chem. Phys., 2, 559 (1934)
22. Bolla, Nuevo Cimento, 10, 101 (1933)
23. Ockmann, H., Adv. in Phys., 7, 199 (1958)

thesR334

The infrared spectrum of H Subscript 2 O

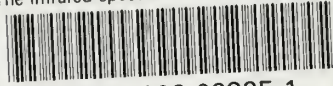

3 2768 002 02325 1

DUDLEY KNOX LIBRARY