

UNCLASSIFIED

AD NUMBER

AD486079

LIMITATION CHANGES

TO:

Approved for public release; distribution is unlimited.

FROM:

Distribution authorized to U.S. Gov't. agencies and their contractors;
Administrative/Operational Use; FEB 1966. Other requests shall be referred to Frankford Arsenal, Philadelphia, PA.

AUTHORITY

USAEA ltr 7 May 1971

THIS PAGE IS UNCLASSIFIED

TECHNICAL SCIENCES CORPORATION

486079
19

TR 1-1

An Investigation of the Feasibility of Placing Timing
Mechanism Shafts Perpendicular to Their Axis of Spin

February 1966

DDC
RECORDED
JUL 27 1966
RESERVED
B

Contract DA-11-022-AMC-2021 (A)

AN INVESTIGATION OF THE
FEASIBILITY OF PLACING TIMER MECHANISM
SHAFTS PERPENDICULAR TO THEIR
AXIS OF SPIN

By
MARTIN SENATOR

Approved

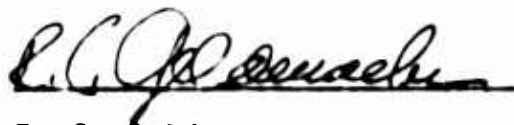

R. C. Geldmacher

Supervising Consultant

Contract DA-11-022-AMC-2021 (A), Frankford Arsenal

TABLE OF CONTENTS

ABSTRACT..... Page 1

GEAR AXES PERPENDICULAR TO THE PROJECTILE AXIS Page 1

 Introduction Page 1

 Tentative Design Page 3

 Estimate of Friction Torque Reflected
 to Mainspring..... Page 9

 Effect of Proposed Orientation on Balance
 Lever Period..... Page 17

 Conclusions..... Page 21

FRICITION TORQUES ON A CONVENTIONAL TIMER..... Page 23

REFERENCES..... Page 29

STATE L3 Page 30

Technical Sciences Corporation

ABSTRACT

In the first part of this investigation the feasibility of constructing a timer mechanism with its gear axes perpendicular to the axis of the projectile is considered. It is found that the potential advantages of this arrangement may not be great enough to warrant solving the practical problems that arise with its use.

The second part of this investigation is concerned with the friction torques of conventionally oriented mechanisms.

GEAR AXES PERPENDICULAR TO THE PROJECTILE AXIS

Introduction Consider a shaft in a timer mechanism that intersects, and is perpendicular to the axis of the projectile. During flight the gear-shaft-pinion assembly is subjected to an acceleration along its axis which is proportional to the square of the spin speed and to the distance from the projectile centerline to the assembly's mass center. During the interval when the projectile is in the rifled gun barrel the assembly is subjected to a transverse acceleration and to an axial acceleration. The timer is not required to operate during this interval even though it may have been turned on when firing was initiated. It is to be expected that during this

interval the spring torque will be balanced by the relatively high friction torques on the timer shafts. When the projectile leaves the barrel the transverse acceleration becomes negligible while the axial acceleration caused by projectile spin remains approximately constant. The timer is required to operate during this interval with minimum friction torque on its shafts.

In a timer with conventional shaft directions, that is with the shaft axes parallel to the projectile axis, the situation is different. During flight the shafts not on the projectile axis are subjected to transverse accelerations and during setback they are subjected to both transverse and axial accelerations.

Conventionally, journal bearings are used to resist transverse loads and a flat thrust collar is used to resist the axial loads of setback. In a previous investigation [1]^{*} the possibility of using sharp vee, jewel type bearings in a conventionally oriented timer was considered. Since these bearings have contact at a radius that is small compared to the shaft radius they offer a potential for low friction and are used in instruments and watches for this reason. It was found, however, that in the application considered, these bearings were inadequate for two basic reasons. First, they had to be an order of magnitude larger than those used in instruments in order to withstand the setback loads. This caused the friction torques during operation to be of the same order of magnitude as those

* Numbers in square brackets designate references on page 29

in journal bearings. Second, they have low resistance to transverse deflection and would not hold the shafts with the necessary precision without additional constraints, which would in turn produce additional friction.

By turning the timer shafts so that they are perpendicular to the projectile centerline and by providing a separate set of bearings to resist the transverse loads of setback two effects occur:

- (1) The steady loads due to projectile spin are changed from a direction transverse to the shaft axis to one parallel to the shaft axis.
- (2) Sizing of the bearings that resist setback is made independent of the sizing of the bearings which resist the spin produced loads, with the possibility of getting lower friction torque.

Tentative Design Before analyzing an untried system in detail, it should be determined in a preliminary fashion, what practical problems are associated with the system because of its basic nature and what the likelihood of solving these problems is. These problems should then be weighed against the potential advantages of the system and the results of this comparison used to determine the extent of the required analysis and the effort to be devoted to solving the associated practical problems. To this end the system shown in Figure 1 was conceived. It has the following features:

- (1) A hardened steel ball outer bearing is used. This eases

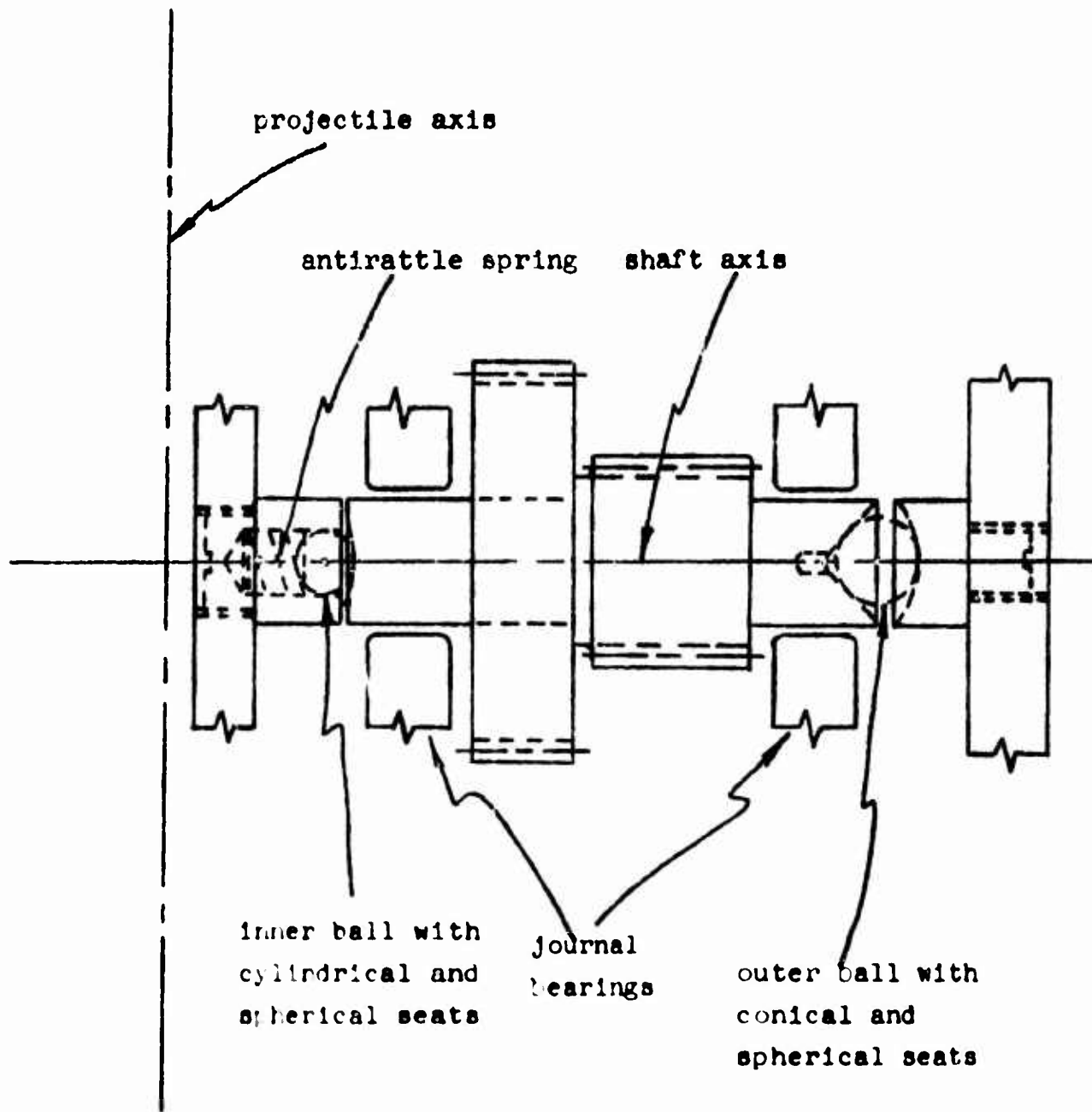

A TENTATIVE DESIGN OF A SHAFT-BEARING-
 ASSEMBLY PERPENDICULAR TO THE PROJECTILE
 AXIS

FIGURE 1

the problem of hardening and precisely grinding the end of the shaft.

(2) A hardened steel or a jewel spherical outer ball seat is used.

(3) A shaft with integral pinion and staked-on gear is used. The shaft contacts the outer ball at a larger radius than the ball does its seat so that slipping occurs at the latter pair of surfaces first. The relatively low contact stress developed between the ball and the shaft end eases the fabrication problem for the shaft end.

(4) Two cylindrical journal bearings with clearance and rounded corners are used to withstand the setback loads.

(5) An inner end ball, with a cylindrical seat, an antirattle spring, and spherical contact with the shaft end is used. It is needed to prevent the shaft from contacting the inner journal bearing during operation. The inner ball is shown on the same side of the projectile axis as the outer ball.

The design as shown has certain limitations associated with its potential advantage of low friction at the small radii of contact between the balls and their seats.

The primary limitation is due to the low resistance of the arrangement to deflections produced by transverse loads. This means that the timer shafts must all be lined up so that each intersects the projectile axis. Deviation of the projectile mass center from its geometric centerline may cause large transverse deflections.

In order to prevent small misalignments from causing extreme transverse deflections relatively high axial forces are required. This necessitates either locating both bearings on the same side of the projectile axis or providing an antirattle spring of tremendous strength.

To get an idea of the possible order of magnitude or loads due to misalignment consider the following numerical values:

Spin Speed, ω_p : 3140 rad/sec (30,000 rpm)

Misalignment: .080 inches

Shaft length between bearings: .24 inches

Weight of shaft: .001 lb

Minimum distance, inner bearing to spin axis: .10 inches

Center of gravity half-way between bearings

The eccentricity of the center of gravity is then (See Figure 2)

$$e = \left\{ (.080)^2 + (.10 + .12)^2 \right\}^{1/2} = .234 \text{ inches}$$

and its acceleration is

$$a = \omega_p^2 e = (3,140)^2 (.234) = 5,980g = 2.305(10^6) \text{ in/sec}^2$$

The axial and transverse components of this acceleration are

$$a_{\text{axial}} = a \cos\alpha = (5,980g)(.22)/(.234) = 5,630g = 2.14(10^6) \text{ in/sec}^2$$

and

$$a_{\text{transverse}} = a \sin\alpha = (5,980g)(.080)/(.234) = 2,050g = .79(10^6) \text{ in/sec}^2$$

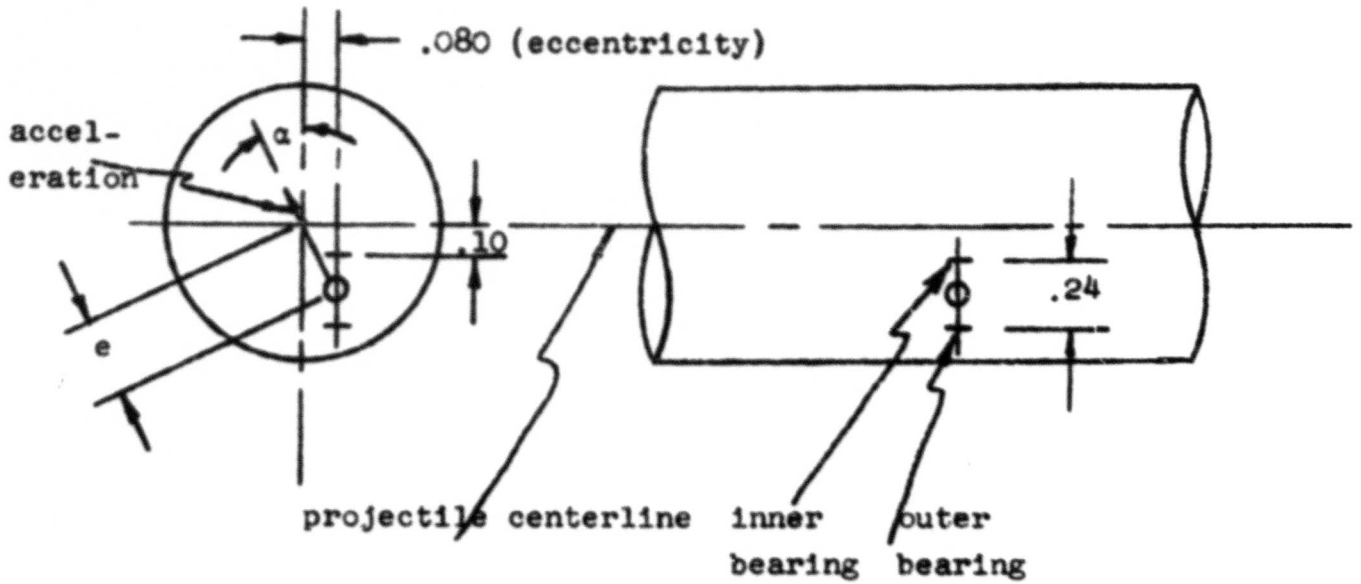

EFFECT OF ECCENTRICITY WHEN BOTH
BEARINGS ARE ON THE SAME SIDE
OF THE PROJECTILE AXIS

FIGURE 2

Thus for a .001 lb. shaft the transverse and axial loads would be about 2.1 and 5.6 lb. respectively under these conditions. This continuously acting transverse load is caused by the combination of accidental eccentricity in one direction and intentional eccentricity in the perpendicular direction. The intentional eccentricity is put in to allow an axial force to be transmitted across the inner bearing. This axial force would generate frictional resistance to transverse deflection at the inner bearing.

If we decide to try to locate the timer shafts with their centers of gravity on the projectile axis, a situation as shown in Figure 3 would result. Assuming five shafts with the middle one nominally centered and allowing for some staggering, the eccentricity of an end shaft could be

$$e = \{ (.08)^2 + (.16)^2 \}^{1/2} = .179 \text{ inches}$$

with a total acceleration of 4,570g and axial and transverse accelerations of 4,080g and 2,040g respectively. These are essentially the same as before.

To summarize so far: The pivot bearings must be able to develop sufficient transverse rigidity to prevent contact with the journal bearings during operation. If this transverse rigidity is attained by transmitting centrifugally generated axial forces across the inner bearing (Figure 2), uncontrollable eccentricities can cause appreciable transverse forces on the shaft. If axial forces on the inner bearing are not intention-

ally generated centrifugally, then one shaft can be placed with its center of gravity nominally on the projectile centerline. The natural staggering of the gearing combined with uncontrollable eccentricity (Figure 3) will then still produce appreciable transverse forces on the shaft. Thus a severe practical problem exists in making the effects of accidental eccentricity negligible.

Estimate of Friction Torque Reflected to Mainspring Here it will be assumed that the accidental eccentricity has been made zero and that sharp vee pivot bearings are resisting only axial load. The friction torque caused by spin forces and reflected to the mainspring will be estimated for these cases:

- (1) Mechanism center 1 inch from projectile axis with balance lever near projectile axis.
- (2) Mechanism center 1 inch from projectile axis with balance lever away from projectile axis.
- (3) Balance lever center on projectile axis.

These three arrangements are shown in Figure 4 which also gives the numbering of the shafts.

The calculated axial forces for arrangement (1) at a spin speed of 30,000 rpm are shown in Table 1, page 12.

Using the equations of Reference [1] we have

$$R_o = \left(\frac{4}{3}\right) \left(\frac{3}{2\pi}\right)^{3/2} \frac{P^{1/2} E_o}{q_o^{3/2}} \quad (146 \text{ of Ref. 1})$$

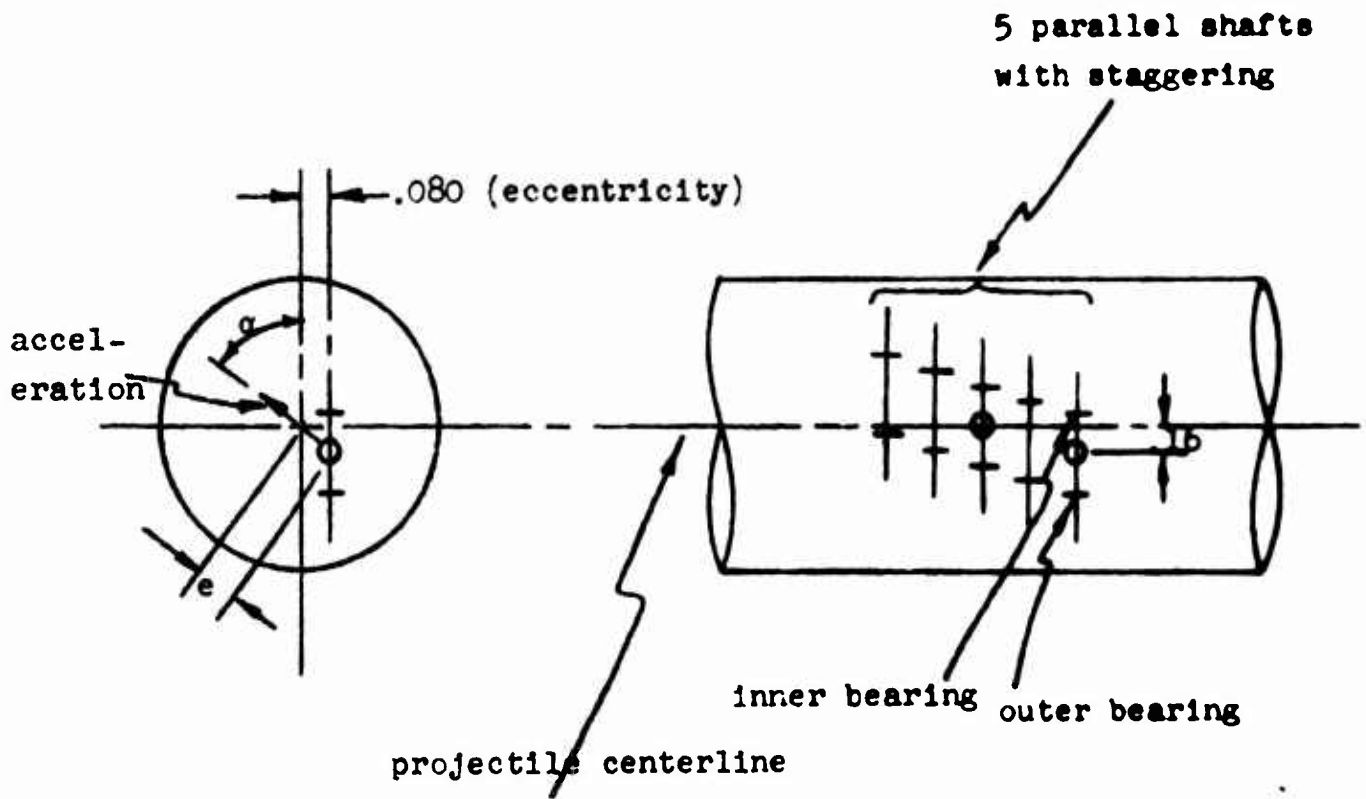

EFFECT OF ECCENTRICITY AND STAGGERING
WHEN THE BEARINGS ARE ON OPPOSITE SIDES
OF THE PROJECTILE AXIS

FIGURE 3

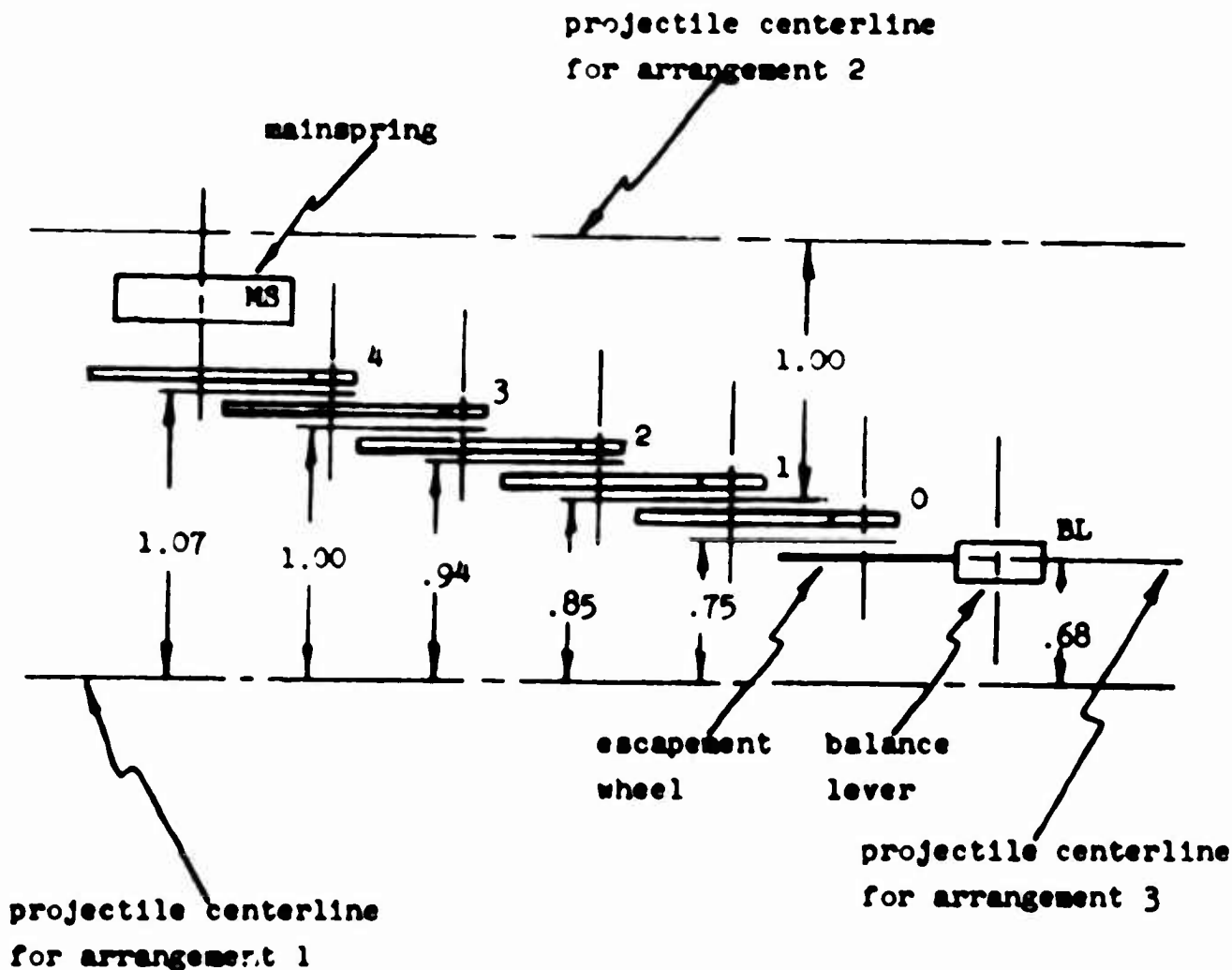

THREE LOCATIONS OF SHAFTS WITH
 RESPECT TO THE PROJECTILE AXIS

FIGURE 4

TABLE 1

CALCULATED AXIAL FORCES FOR ARRANGEMENT (1)
 AT A SPIN SPEED OF 30,000 rpm

Shaft Number	Eccentricity (inches)	Axial Acceleration (g's)	Estimated Weight (lbx10 ³)	Axial Force (lb)
MS	1.12	26,700	5.5*	157.*
4	1.07	27,400	3.24	88.6
3	1.00	25,600	.972	24.9
2	.94	24,000	.618	14.8
1	.85	21,800	.503	11.0
0	.75	19,200	.332	6.40
BL	.68	17,400	.185	3.22

* Uncertainty as to how much spring weight to assume to be supported by the bearing has led to disregarding any friction caused by this force in the totals of Tables 2 to 4

to size the bearings where

$$\frac{1}{R_0} = \frac{1}{R_1} + \frac{1}{R_2} \quad (130 \text{ of Ref. 1})$$

$$\frac{1}{E_0} = \frac{1 - \nu_1^2}{E_1} + \frac{1 - \nu_2^2}{E_2} \quad (131 \text{ of Ref. 1})$$

and

R_1 is the (negative) radius of the bearing seat

R_2 is the radius of the shaft end or ball

E_1 and E_2 are the moduli of elasticity of the two materials

ν_1 and ν_2 are Poisson's ratios

q_0 is the design maximum compressive stress

P is the axial load

The friction torque on a bearing with coefficient of friction μ and maximum compressive stress q_0 produced by an axial load P is then

$$T_{fr} = \left(\frac{1}{8}\right) \left(\frac{3}{2}\right)^{3/2} (\pi)^{1/2} \mu \frac{P^{3/2}}{q_0^{1/2}} \quad (151 \text{ of Ref. 1})$$

or

$$T_{fr} = .408 \mu \frac{P^{3/2}}{q_0^{1/2}}$$

Using the numerical values $q_0 = 285,000$ psi for hardened steel on sapphire [2] and $\mu = .17$ for these materials we can find the torques required at the shafts to overcome friction due to the axial (centrifugal) loads on the outer bearing. The results are shown in Table 2 (page 15) which also gives the ideal torque required at the mainspring to overcome these friction torques.

It may be seen that this is potentially a high torque to overcome at the mainspring shaft.

The effect of reversing the eccentricities and locating the balance lever on the outside (arrangement 2) is shown in Table 3 on page 16.

It may be seen that arrangement 1 gives somewhat lower reflected friction torque although the orders of magnitude are the same.

The torque values from these tables can be modified for other friction coefficients μ , or design bearing stresses q_0 , by noting that

$$T_{fr} = T_{fr} \text{ (Table 2)} \left(\frac{\mu}{.17} \right) \left(\frac{285,000}{q_0} \right)^{1/2}$$

For different gear ratios, shaft weights, or eccentricities the calculations have to be repeated.

TABLE 2

CALCULATED FRICTION TORQUES FOR
 ARRANGEMENT 1 FOR A SPIN SPEED OF 30,000 rpm,
 A COEFFICIENT OF FRICTION OF .17, AND A
 DESIGN MAXIMUM COMPRESSIVE STRESS OF 285,000 psi

Shaft Number	Gear Ratio to Mainspring	P (lb.) (From Table 1)	T _{fr} at Shaft (lb.in.)	T _{fr} Reflected to Mainspring (lb.in.)
MS	1	-	-	-
4	2.33	88.6	.1082	.252
3	7.00	24.9	.0161	.113
2	21.0	14.8	.00652	.137
1	78.8	11.0	.00472	.372
0	354.	6.40	.00210	.744
BL	-	3.22	.000750	-

Total = 1.618 lb.in.
 = 25.9 oz.in.

TABLE 3

CALCULATED FRICTION TORQUES FOR
 ARRANGEMENT 2 FOR A SPIN SPEED OF 30,000 rpm,
 A COEFFICIENT OF FRICTION OF .17 AND A
 DESIGN MAXIMUM COMPRESSIVE STRESS OF 285,000 psi

Shaft Number	Eccentricity (inches) *	Axial Force (lb.)	T _{fr} at Shaft (lb.in.)	T _{fr} Reflected to Main-spring (lb.in.)
MS	.70	-	-	-
4	.75	62.3	.0638	.1486
3	.85	21.2	.01263	.0835
2	.94	14.8	.00739	.155
1	1.00	12.86	.00596	.470
0	1.07	9.10	.00356	1.261
BL	1.15	5.44	.001642	-

Total = 2.104 lb.in.
 = 33.6 oz.in.

* All eccentricities except that of shaft number 1 are estimated independently of those in arrangements (1) and (3)

As opposed to these pessimistic estimates we may consider Arrangement 3, with the balance lever center of mass exactly at the spin axis and the only eccentricities due to a small staggering effect. The results of this calculation are shown in Table 4, page 18.

It may be noted that the friction arising from the transverse loads applied at the gear teeth has been realistically neglected in Tables 2 and 3 but that this neglect is not justified in the optimistic Table 4. Table 4 does indicate, however, the potentially lower friction possible when the mechanism is centered on the spin axis.

These results may be summarized as follows: If we assume that all the shaft axes actually do intersect the spin axis, and the loads are thus applied axially, then at 30,000 rpm the torque required at the mainspring to overcome the friction caused by these axial loads is of the order of the available torque when the eccentricity of the mechanism is about one inch. If the centrifugal forces are not used to generate transverse stiffness, then the eccentricity of the mechanism can be reduced and friction torques an order of magnitude lower can be attained.

Effect of Proposed Orientation on Balance Lever Period Figure 5 shows the balance lever for the on-center Arrangement 3. It is shown in its equilibrium position with its center of mass on the spin centerline of the projectile. It may be noted that when the balance lever is rotated from its equilibrium position, centrifugal forces act on the two masses to increase

TABLE 4

CALCULATED FRICTION TORQUES FOR
 ARRANGEMENT 3 FOR A SPIN SPEED OF 30,000 rpm,
 A COEFFICIENT OF FRICTION OF .17 AND A
 DESIGN MAXIMUM COMPRESSIVE STRESS OF 285,000 psi

Shaft No.	Eccentricity (inches) *	Axial Force (lb.)	T _{fr} at Shaft (lb.in.)	T _{fr} Reflected To Mainspring (lb.in.)
MS	.15	-	-	-
4	.13	10.75	.00457	.01065
3	.11	2.73	.000584	.00409
2	.09	1.42	.000219	.00461
1	.07	.900	.0001105	.00872
0	.05	.424	.0000357	.01262
BL	0	0	-	-

Total = .04069 lb.in.
 = .652 oz.in.

* All eccentricities except that of shaft number BL are estimated independently of those in arrangements (1) and (2).

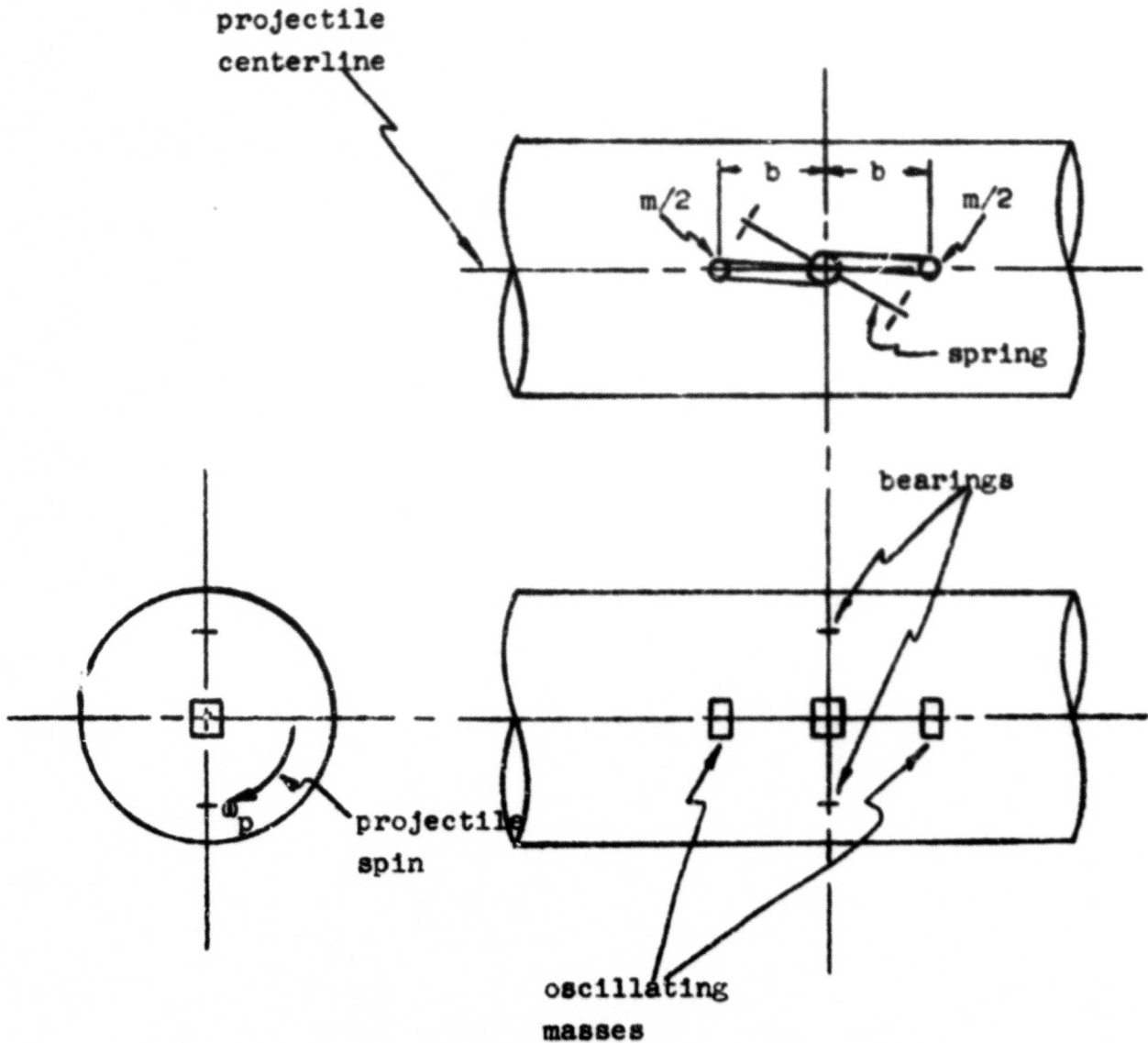

BALANCE LEVER IN ITS EQUILIBRIUM POSITION
WHEN ITS CENTER OF MASS LIES ON THE
SPIN CENTERLINE OF THE PROJECTILE

FIGURE 5

this deflection. Assuming for the calculations to follow that the spring stiffness is not affected by spin, the effective stiffness becomes

$$K_t \text{ effective} = K_t \text{ spring} - m\omega_p^2 b^2$$

Assuming that K_t effective is equal to K_t design at a design spin speed ω_p , it will increase to a higher value at a lower spin speed. For a numerical estimate of this effect take present "typical" numerical values as

$$b = .701/2 \text{ inches}$$

$$mg = 115.5 \times 10^{-6} \text{ lb.}$$

and

$$f_n 30,000 = 81.5 \text{ cps}$$

and calculate the natural frequency when the spin speed is half of the design maximum spin speed of 30,000 rpm. We have

$$\begin{aligned} K_t 30,000 &= I \omega_n^2 30,000 = (.0366 \times 10^{-6})(.262 \times 10^6) \\ &= .0096 \text{ in.lb./rad.} \end{aligned}$$

$$K_t 15,000 = K_t 30,000 + 4 \left[1 - \left(\frac{15}{30} \right)^2 \right] m\omega_{15,000}^2 b^2$$

$$f_n 15,000 = f_n 30,000 \left(1 + 3\omega_{15,000}^2 / \omega_n^2 30,000 \right)^{1/2}$$

$$= 81.5 (5.43)$$

$$= 441 \text{ cps}$$

which obviously cannot be tolerated.

If the equilibrium position is rotated 90° as shown in Figure 6 a similar effect occurs. In this case a small rotation from the equilibrium position does not change the centrifugal forces to first order in small quantities, but does change the moment arms of these forces by first order quantities. The effective spring constant becomes

$$K_t \text{ effective} = K_t \text{ spring} + m\omega_p^2 b^2$$

which, except for a difference in sign causes the same difficulties as before.

For the mechanism of Table 2, where the balance lever has an intentional eccentricity similar effects occur.

It can be seen that since the signs of the spin sensitive terms depend on the orientation of the two masses which effectively determine the motion of the balance lever, it would be possible to cancel out these effects by using a balance lever with suitable symmetry.

Conclusions From the discussion and preliminary calculations we may list the following conclusions.

There is a possibility of considerably reducing friction torque during operation of a conventional timer by turning its axis 90° , using sharp vee pivot bearings, and locating its center of gravity on the spin axis of the projectile.

There are, however, severe practical disadvantages asso-

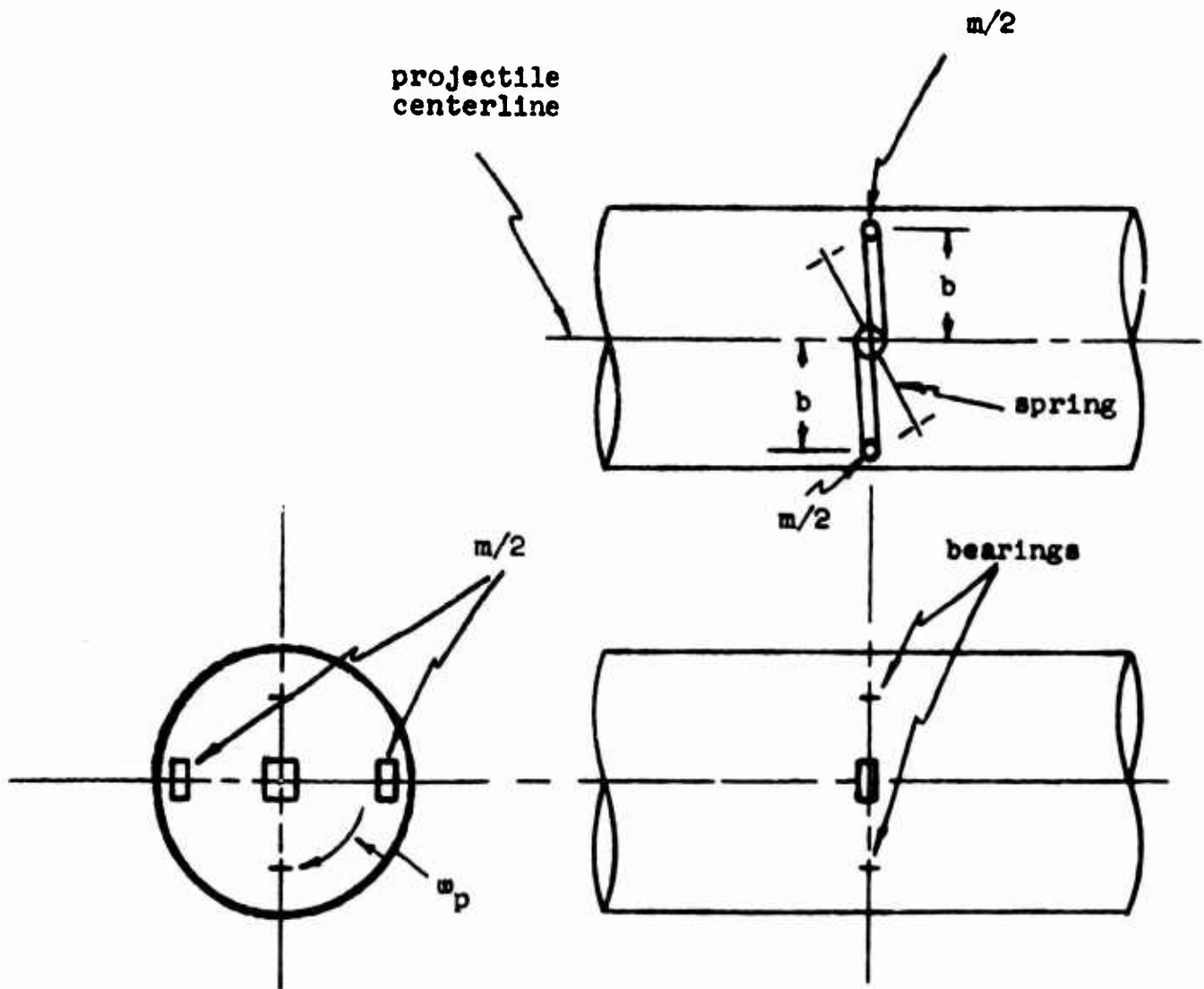

BALANCE LEVER IN ITS EQUILIBRIUM POSITION
WHEN ITS CENTER OF MASS LIES ON THE SPIN
CENTERLINE OF THE PROJECTILE
(Equilibrium position rotat-
ed 90° from that of figure 5)

FIGURE 6

ciated with this change. They are (no attempt is made here to estimate the relative importance of each disadvantage):

1. All shafts must intersect the spin axis of the projectile and must therefore project on a straight line. This may cause an unwieldy shape to be required for the timer.
2. Transverse accelerations of the order of 2000g can arise due to accidental eccentricities. The sharp vee pivot bearings have negligible resistance to transverse deflection caused by the inertia forces arising from these accelerations and excessive deflections of the shafts will occur.
3. If axial forces are generated by spin in order to create sufficient axial reaction to cause transverse frictional resistance to deflection, then the friction torques arising from these axial reactions are of the order of magnitude of the mainspring capabilities. Thus the low friction advantage of the arrangement would be lost.
4. For a conventional two-mass balance lever the effective spring constant depends upon the spin speed. Thus either the frequency will be sensitive to spin speed or an unconventional balance lever shape must be used.

FRICTION TORQUES ON A CONVENTIONAL TIMER

In this section friction torques on a conventional timer are calculated. First the mechanism centerline is taken to coincide with the spin axis of the projectile and then it is taken as being eccentric by .080 inches in the direction which increases the escapewheel's eccentricity by this amount.

If a cosine distribution of normal force in the circumferential direction is assumed for a journal bearing, then the following relations can be derived for maximum pressure and friction torque.

$$p_m = \frac{P_{tr}}{d} \frac{4}{\pi} \quad (123 \text{ of Ref. 1})$$

$$\begin{aligned} T_{fr} &= (P_{tr})(d/2)(\mu)(4/\pi) \\ &= (P_{tr})(d/2)(\mu)(1.275) \end{aligned} \quad (128 \text{ of Ref. 1})$$

where P_{tr} is the transverse load applied to the bearing, p_m is the maximum force per unit length of circumference, d is the diameter, μ the coefficient of friction, and T_{fr} the friction torque.

It may be noted that:

1. Although all the friction forces are exerted at the shaft radius, the friction torque is greater than $(P_{tr})(d/2)(\mu)$ because more normal force than P_{tr} is generated to resist P_{tr} , due to the angularity of the normal force components with respect to P_{tr} .
2. The maximum pressure is 1.275 times (P_{tr}/d) and the effective friction radius is 1.275 times the radius of the shaft.
3. If a uniform pressure distribution is assumed, the corresponding values are 1.00 and 1.571. In this case the maximum pressure is less as more of the surface is subjected to this pressure but the friction torque is higher for the same reason.
4. The factor 1.275 in the torque equation can be reduced to 1.00 if all the pressure is concentrated in line with P_{tr} . This means relatively large clearance and is unacceptable in

a mechanism of this type.

For the present calculations we will use the cosine distribution as being the most reasonable for this mechanism. We will also assume that the net force, $P_{t,r}$, acting on the two bearings equals the applied transverse force. This will occur if the plates have at least a slight meridional curvature so that both ends of the shafts can be considered as simply supported (See page 93 of Reference 1).

The results of the friction calculations for no eccentricity are tabulated in Table 5, page 26, which also shows the pertinent mechanism dimensions and weights which were used.

It may be seen that for coefficients of friction of .17 the calculated friction torque at the mainspring is of the order of magnitude of the available spring torque. It may be noted that:

1. This calculation is valid as long as the transverse forces produced at the bearings by transmitted torque are negligible compared to those produced by centrifugal acceleration.
2. Subject to this limitation the friction torque is directly proportional to coefficient of friction (taken as .17 here) and to the square of the spin speed (taken as 30,000 rpm here).

In Table 6, page 27, calculations are given for the same mechanism with an eccentricity of .080 inches in a direction toward the escapewheel center, as this produces the greatest effect at the mainspring.

It may be seen that for an eccentricity of this (pessimistic but possible) magnitude in this direction a considerable

TABLE 5

FRICION CAUSED BY CENTRIFUGAL FORCE
MECHANISM ON CENTER

Shaft No.	Eccentricity (in.)	Weight (lb x 10 ³)	P _{tr.} ° (lb)	Diameter (mil.)	Gear Ratio to Main-Spring	T _{fr} at Shaft ** (lb.in.)	T _{fr} at Main Spring (lb.in.)
MS	0	5.5	0	97.8	1	0	0
4	.314	3.24	26.1	49.2	2.33	.1388	.324
3	.284	.972	7.06	30.0	7.00	.0229	.161
2	.312	.618	4.92	22.1	21.0	.01178	.247
1	.210	.503	2.70	18.3	78.8	.00535	.422
0	.211	.332	1.79	18.6	354.	.00360	1.275
BL	0	.185	0	18.	-	0	-

• Due to a spin speed of 30,000 rpm

Total = 2.43 lb.in.

•• Due to a coefficient of friction of .17

= 59 oz.in.

increase in friction torque will occur.

Another general comment may be made. The friction coefficient used here is .17. Before using an experimentally determined friction coefficient it should be determined which circumferential pressure distribution has been assumed by the experimenter. For the three more or less limiting cases considered here there are factors of 1, 1.275, and 1.571 which would be used in transforming measured values of friction torque, transverse force, and shaft diameter to friction coefficient. Considerable differences can result if we are unaware which value an experimenter has used.

It may also be noted that the effect of gear ratio in increasing the reflected torque to the mainspring more than counteracts the effect of reduced weight in decreasing this torque as we go toward the high speed end of the gear train.

Technical Sciences Corporation

REFERENCE

- [1] M. Senator, "An Investigation of Loads, Stress Levels, and Friction Torques of Timer-Mechanism Bearings," General Technology Corporation TRX-3, August, 1964.
- [2] M. Senator, "An investigation of Loads, Stress Levels, and Friction Torques of Timer-Mechanism Bearings," General Technology Corporation TRX-3, August, 1964, pp 99-109.

SYMBOLS

ω_p	Angular velocity of projectile	rad/sec
R_o	$\frac{1}{R_o} = \frac{1}{R_1} + \frac{1}{R_2}$	
R_1	Bearing radius	in
R_2	Pivot radius	in
P	Axial load on shaft pivot and bearing	lb
E_o	$\frac{1}{E_o} = \frac{1 - \nu_1^2}{E_1} + \frac{1 - \nu_2^2}{E_2}$	
E_1	Bearing modulus of elasticity	psi
E_2	Shaft modulus of elasticity	psi
ν_1	Poisson's ratio for bearing	
ν_2	Poisson's ratio for shaft	
q_o	Maximum pressure on contact area	psi
μ	Coefficient of friction	
$T_{fr.}$	Friction torque	in lb
$m/2$	Balance lever masses	
b	Distance from balance lever masses to center of rotation.	
K_t	Balance lever spring stiffness	
I	Moment of inertia of balance lever	
ω_n	Natural frequency of balance lever	rad/sec
f_n	Natural frequency of balance lever	cps

SYMBOLS

P_{tr}	Transverse load applied to journal bearing	lb
P_m	Maximum force per unit length of journal bearing circumference	lb/in
d_s	Diameter of shaft	in

Unclassified

Security Classification

DOCUMENT CONTROL DATA - R&D		
<i>(Security classification of title, body of abstract and indexing annotation must be entered when the overall report is classified)</i>		
1. ORIGINATING ACTIVITY (Corporate author) Technical Sciences Corporation 474 Summit Street Elgin, Illinois		2a. REPORT SECURITY CLASSIFICATION Unclassified
		2b. GROUP N/A
3. REPORT TITLE AN INVESTIGATION OF THE FEASIBILITY OF PLACING TIMER MECHANISM SHAFTS PERPENDICULAR TO THEIR AXIS OF SPIN		
4. DESCRIPTIVE NOTES (Type of report and inclusive dates) Final (1 of 2) 2/12/65 - 3/15/66		
5. AUTHOR(S) (Last name, first name, initial) Senator, Martin		
6. REPORT DATE March 1966	7a. TOTAL NO. OF PAGES 30	7b. NO. OF REFS 1
8a. CONTRACT OR GRANT NO. DA-11-022-AMC-2021(A)	9a. ORIGINATOR'S REPORT NUMBER(S) TR 1-1	
8b. PROJECT NO. AMCMS 5523.11.55700.01	9b. OTHER REPORT NO(S) (Any other numbers that may be assigned this report) N/A	
8c.		
8d.		
10. AVAILABILITY/LIMITATION NOTICES Qualified requesters may obtain copies of this report from DDC		
11. SUPPLEMENTARY NOTES N/A	12. SPONSORING MILITARY ACTIVITY U. S. A. Munitions Command	
13. ABSTRACT <p>In the first part of this investigation the feasibility of constructing a timer mechanism with its gear axes perpendicular to the axis of the projectile is considered. It is found that the potential advantages of this arrangement may not be great enough to warrant solving the practical problems that arise with its use.</p> <p>The second part of this investigation is concerned with the friction torques of conventionally oriented mechanisms.</p>		

Unclassified

Security Classification

14. KEY WORDS	LINK A		LINK B		LINK C	
	ROLE	WT	ROLE	WT	ROLE	WT
Fuse, Mechanical, Time, Bearings Journals, Thrust Bearings Miniature Bearings						

INSTRUCTIONS

1. ORIGINATING ACTIVITY: Enter the name and address of the contractor, subcontractor, grantee, Department of Defense activity or other organization (corporate author) issuing the report.

2a. REPORT SECURITY CLASSIFICATION: Enter the overall security classification of the report. Indicate whether "Restricted Data" is included. Marking is to be in accordance with appropriate security regulations.

2b. GROUP: Automatic downgrading is specified in DoD Directive 5200.10 and Armed Forces Industrial Manual. Enter the group number. Also, when applicable, show that optional markings have been used for Group 3 and Group 4 as authorized.

3. REPORT TITLE: Enter the complete report title in all capital letters. Titles in all cases should be unclassified. If a meaningful title cannot be selected without classification, show title classification in all capitals in parenthesis immediately following the title.

4. DESCRIPTIVE NOTES: If appropriate, enter the type of report, e.g., interim, progress, summary, annual, or final. Give the inclusive dates when a specific reporting period is covered.

5. AUTHOR(S): Enter the name(s) of author(s) as shown on or in the report. Enter last name, first name, middle initial. If military, show rank and branch of service. The name of the principal author is an absolute minimum requirement.

6. REPORT DATE: Enter the date of the report as day, month, year, or month, year. If more than one date appears on the report, use date of publication.

7a. TOTAL NUMBER OF PAGES: The total page count should follow normal pagination procedures, i.e., enter the number of pages containing information.

7b. NUMBER OF REFERENCES: Enter the total number of references cited in the report.

8a. CONTRACT OR GRANT NUMBER: If appropriate, enter the applicable number of the contract or grant under which the report was written.

8b, 8c, & 8d. PROJECT NUMBER: Enter the appropriate military department identification, such as project number, subproject number, system numbers, task number, etc.

9a. ORIGINATOR'S REPORT NUMBER(S): Enter the official report number by which the document will be identified and controlled by the originating activity. This number must be unique to this report.

9b. OTHER REPORT NUMBER(S): If the report has been assigned any other report numbers (either by the originator or by the sponsor), also enter this number(s).

10. AVAILABILITY/LIMITATION NOTICES: Enter any limitations on further dissemination of the report, other than those imposed by security classification, using standard statements such as:

- (1) "Qualified requesters may obtain copies of this report from DDC."
- (2) "Foreign announcement and dissemination of this report by DDC is not authorized."
- (3) "U. S. Government agencies may obtain copies of this report directly from DDC. Other qualified DDC users shall request through _____."
- (4) "U. S. military agencies may obtain copies of this report directly from DDC. Other qualified users shall request through _____."
- (5) "All distribution of this report is controlled. Qualified DDC users shall request through _____."

If the report has been furnished to the Office of Technical Services, Department of Commerce, for sale to the public, indicate this fact and enter the price, if known.

11. SUPPLEMENTARY NOTES: Use for additional explanatory notes.

12. SPONSORING MILITARY ACTIVITY: Enter the name of the departmental project office or laboratory sponsoring (paying for) the research and development. Include address.

13. ABSTRACT: Enter an abstract giving a brief and factual summary of the document indicative of the report, even though it may also appear elsewhere in the body of the technical report. If additional space is required, a continuation sheet shall be attached.

It is highly desirable that the abstract of classified reports be unclassified. Each paragraph of the abstract shall end with an indication of the military security classification of the information in the paragraph, represented as (TS), (S), (C), or (U).

There is no limitation on the length of the abstract. However, the suggested length is from 150 to 225 words.

14. KEY WORDS: Key words are technically meaningful terms or short phrases that characterize a report and may be used as index entries for cataloging the report. Key words must be selected so that no security classification is required. Identifiers, such as equipment model designation, trade name, military project code name, geographic location, may be used as key words but will be followed by an indication of technical context. The assignment of links, rules, and weights is optional.

Unclassified

Security Classification