

UNCLASSIFIED

AD NUMBER

AD486375

LIMITATION CHANGES

TO:

Approved for public release; distribution is unlimited.

FROM:

Distribution authorized to U.S. Gov't. agencies and their contractors;
Administrative/Operational Use; JAN 1966. Other requests shall be referred to Air Force Aero Propulsion Lab., Wright-Patterson AFB, OH 45433.

AUTHORITY

AFAPL ltr, 4 May 1973

THIS PAGE IS UNCLASSIFIED

NORD-AVIATION

486375



CONTRACT AF 61 (052) -750

EXPERIMENTAL AND DESIGN STUDIES

FOR TURBO - RAMJET COMBINATION ENGINE

FINAL REPORT

SPECIFICATIONS AND PERFORMANCE

THIS DOCUMENT IS SUBJECT TO SPECIAL EXPORT CONTROLS
AND EACH TRANSMITTAL TO FOREIGN GOVERNMENTS OR
FOREIGN NATIONALS MAY BE MADE ONLY WITH PRIOR
APPROVAL OF THE TURBINE ENGINE DIVISION, AIR FORCE
AERO PROPULSION LABORATORY, WRIGHT-PATTERSON
AIR FORCE BASE, OHIO.

VOLUME 1

JANUARY 1961

AFAPL-TR-66-34

Volume I

EXPERIMENTAL AND DESIGN STUDIES
FOR TURBO-RAMJET COMBINATION ENGINE
Volume I - Specifications and Performance

P. Chaulin
M. Ravel
A. Gozlan
Nord Aviation (France)

This Document is Subject to Special Export
Controls and Each Transmittal to Foreign
Governments or Foreign Nationals may be
Made Only With Prior Approval of the
Air Force Aero Propulsion Laboratory.

Technical Report AFAPL-TR-66-34, Volume
January 1966

Air Force Aero Propulsion Laboratory
Research and Technology Division
Air Force Systems Command
Wright-Patterson Air Force Base, Ohio 45433

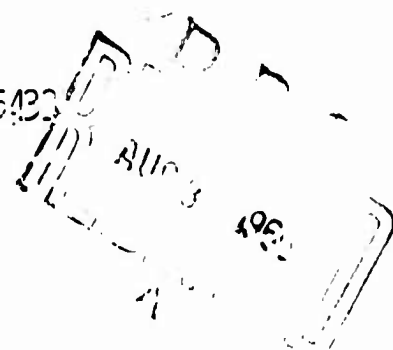

NOTICES

Foreign announcement and distribution of this report are not authorized.

Qualified users may obtain copies of this report from the Defense Documentation Center (DDC), Cameron Station, Building 5, 5010 Duke Street, Alexandria, Virginia, 22314.

The distribution of this report is limited because it contains technology identifiable with items on the strategic embargo lists excluded from export or re-export under U. S. Export Control Act of 1949 (63 STAT.7), as amended (50 U.S.C. App. 2020.2031), as implemented by AFR 400-10.

FOREWORD

This report was prepared by Nord Aviation, France under Contract AF 61(052)-750 initiated under Project No. 3012, Task No. 301203. The work was administered under the direction of the Air Force Aero Propulsion Laboratory, Turbine Engine Division, with Isak J. Gershon as project engineer.

The publication of this report does not constitute approval by the Air Force of the findings or the conclusions contained herein. This report has been reviewed and is published only for the exchange and stimulation of ideas.



E. C. Simpson
Chief, Turbine Engine Division
Air Force Aero Propulsion Laboratory

AF 61(052)-750
5147/NIOBE IV/29/Z

January 1966

FINAL REPORT
=====

EXPERIMENTAL AND DESIGN STUDIES
FOR TURBO-RAMJET COMBINATION ENGINE
VOLUME 1 : SPECIFICATIONS AND PERFORMANCE

NORD-AVIATION
DEPARTMENT "PROPULSEURS"
PARIS (CHATILLON)FRANCE

The research reported in this document has been sponsored by the AERONAUTICAL SYSTEMS DIVISION, AFSC, through the European Office of Aerospace Research, United States Air Force.

INTRODUCTION

This study which can be considered as a follow up of the previous contract (AF 61 (052) 670 TURBOFAN-RAMJET ENGINE STUDIES - May 1964) aims at pursuing the demonstration of Nord-Aviation's combined turbofan-ramjet engine efficiency and feasibility within the Mach number range from 0 to 4.

The object of this contract is to define a combined engine around the dry section of turbofan SNECMA TF 106, selected at the close of the preceding contract, and to establish a complete performance characteristics system up to Mach 4. An experimental part of this study has for object the design and testing of a combustion chamber functioning satisfactorily in the Mach number range from 0 to 4 up to 100 000 feet altitude and for a widespread range of equivalence ratio, in a word covering all the needs of propulsion of a highly supersonic vehicle.

We recall hereunder Nord-Aviation's historic in the field of combined turboramjet engines.

Since 1951 Nord-Aviation started studying Ramjets and Combined Turbo-Ramjet engines : definitions, development, manufacture, bench and flight tests. In 1953 the Company designed the Mach 2.2. experimental aircraft, named "GRIFFON". It was propelled by a combined turbo-ramjet engine, 330 flights were carried out.

Studies on combined engines are pursued with the object of extending the flight field up to high Mach numbers, the satisfactory performance characteristics of the gas turbine engines at the low and moderate Mach numbers being however retained as well as those of the ramjet at high Mach numbers. The latest studies were sponsored by the

AERONAUTICAL SYSTEMS DIVISION, AIR FORCE SYSTEMS COMMAND, through the European Office of Aerospace Research, U.S.A.F.

In the most advanced design, the axial compressor turbojet engine of the "GRIFFON" is replaced by a front-fan engine, its jet nozzle opening into the combined engine combustion chamber ; this arrangement affords, if necessary, afterburning of the primary flow. The ram duct encompasses the gas turbine engine ; the air surrounding the fan is mixed, in an annular chamber, with the secondary air delivered by the fan ; the resulting mixed flow feeds the combustion chamber whose combustion system surrounds the rear end of the turbofan. Owing to movable flaps located at the delivery end of the fan, it is possible to operate either in the pure turbofan configuration or in the pure ramjet configuration.

There are only one air inlet duct, and one exit nozzle which is of the convergent-divergent type.

This powerplant can meet the propulsion requirements of a supersonic interceptor, a long range supersonic bomber, a high altitude reconnaissance aircraft, up to a Mach number for which the kinetic heating problems can be solved by the convenient selection of materials, of insulating techniques, or by the use of fuel as a heat sink ; this is the Mach 3 to 4/4.5 category.

The use of cryogenics allows an extension of the use of Nord-Aviation's combined turbofan-ramjet engine up to hypersonic flights, without modifying the basic configuration ; this engine could meet the propulsion requirements of a hypersonic aircraft, or of a reusable air-breathing launcher.

The first contract, AF 61 (052)-479, with the A.R.S.C., U.S.A.F., was the object of a preliminary study of a combined engine consisting of a forward-fan engine and ramjet assembly for a Mach 3 long range transport, the X 61 TURBO-RAMJET POWERPLANT - June 1961. This combined engine was based on a hypothetical turbofan adapted to

Mach 3, the characteristics of which had been supplied by WADD. This study enabled us to raise most of the problems involved in the use of a combined engine on a supersonic aircraft.

The second contract, AF 61 (052) 570 (X 71 - TURBOPAN-RAMJET POWERPLANT - February 1962) describes the essential characteristics of a combined engine built around an extrapolation of turbofan PRATT AND WHITNEY JTF 10, for a Mach 3 supersonic transport. This study proved that a combined engine based on an existing turbofan, adapted to the subsonic flight, is quite satisfactory.

The third contract, AF 61 (052) - 670 (TURBOPAN-RAMJET ENGINE STUDIES - May 1964), was intended to prove the feasibility, and the efficiency of the Nord-Aviation combined engine over a Mach range from 0 to 4.5. A theoretical part consisted in comparing three combined engines built around the following three turbofan engines : SNECMA TF 106, BRISTOL SIDDELEY PEGASUS 5, PRATT AND WHITNEY TF 33 P 7 ; these engines having satisfactory performance characteristics the adaptation flexibility of the combined engine design was thus enhanced. Experimental work carried out made it possible to design a correct contour for the turbofan subsonic inlet and an efficient system for mixing the ramjet flow with the fan flow, and to establish the correct operation of the common exit nozzle throughout the engine operational range.

The contract, object of this final report, AF-61 (052) 750 (EXPERIMENTAL AND DESIGN STUDIES FOR TURBO-RAMJET COMBINATION ENGINE) is the continuation of the previous contract ; in fact, the last two contracts can be considered as elements of the same study. It should be reminded that the first part of this contract is meant to define a combined engine based on the SNECMA TF 106 turbofan, chosen at the close of the previous contract : establishment of a general layout of the combined engine and tracing of a complete performance characteristics chart up to Mach 4, for altitudes varying from 0 to 100,000 feet. The second part was experimental, its purpose was to define and study a combustion chamber covering the requirements of the following

field of flight : altitude from 0 to 100,000 feet, flight Mach number from 0 to 4. The two-dimensional model represents a full-size sector of an actual combustion chamber. The tests took place at Nord-Aviation 's test center of LES GATINES and at the powerplant test center (Centre d'Essais des Propulseurs, C.E.P.) of SACLAY.

LIST OF VOLUMES

The study comprises the following volumes :

Volume 1 - SPECIFICATIONS AND PERFORMANCE	5147/NIOBE IV/29/Z
Volume 2 - CALCULATION ANALYSIS	
2-1 CYCLE ANALYSIS	5148/NIOBE IV/30/Z
2-2 SYSTEM C_nH_{2n}/AIR .-ANALYSIS OF THERMODYNAMIC PROPERTIES	5149/NIOBE IV/31/Z
Volume 3 - DATA	
3-1 TURBOPAN DATA	5150/NIOBE IV/32/Z
3-2 GENERAL DATA	5151/NIOBE IV/33/Z
Volume 4 - CALCULATED RESULTS	
4-1 PARAMETRIC CALCULATIONS OF PERFORMANCE CHARACTERISTICS	5152/NIOBE IV/34/Z
4-2 INTERNAL FLOW CHARACTERISTICS	5153/NIOBE IV/35/Z
Volume 5 - COMBUSTION -TEST INSTALLATION	5154/NIOBE IV/36/Z
Volume 6 - COMBUSTION TESTS AT LES GATINES	5155/NIOBE IV/37/Z
Volume 7 - COMBUSTION TESTS AT SACLAY	5156/NIOBE IV/38/Z
Volume 8 - DRAWINGS	
8-1 ENGINE DESIGN	
8-2 COMBUSTION TESTS	

RESPONSIBLE ENGINEERS

The engineers below took part in this study :

Mrs. P. ADAM	Combustion tests (Data analysis)
Mr. M. BOEHLER	Combustion test benches. Combined engine general layout.
Mr. R. BOURELLY	Coordination-Administration
Mr. S. DZALBA-LYNDIS	Definition of the Combustion Chamber model for rheoelectrical simulation.
Mr. C. GHINTER	Combustion tests
Mrs J. GUYOT	Programming on IBM 7040
Mr. P. GUYOT	Propulsion analysis. Performance characteristics. Engine design.
Mrs J. LAURENT	Performance characteristics
Mrs J. LAUROUA	Performance characteristics
Mr. R. LEFEBVRE	Combustion tests
Mr. J. LEFEBVRE	Combustion tests
Mr. G. LE GOAZIOU	Combustion test benches. Combined engine general layout.

Under the supervision of :

Mr. P. CHAULIN	Chief of Department, Propulsion Group
Mr. M. RAVEL	Assistant to the Chief Engineer
Mr. A. GOZLAN	Chief Engineer of the Propulsion Group
Mr. G. PAYELLE	Deputy Technical Director of the Aerospace Division
Mr. J. DUPIN	Technical Director of the Aerospace Division

CONTENTS

- 1 - INTRODUCTION
- 2 - GENERAL DESCRIPTION
- 3 - DEFINITION OF THE X 81 COMBINED ENGINE
 - 3-1 Major dimensions
 - 3-2 Structure
 - 3-2-1 Front part
 - 3-2-2 Rear part
 - 3-3 Control system
- 4 - PERFORMANCE CHARACTERISTICS
 - 4-1 Performance characteristics for sea level static conditions
 - 4-2 Performance characteristics during flight
 - 4-2-1 Air mass flow
 - 4-2-2 Performance characteristics without afterburning
 - 4-2-3 Performance characteristics with afterburning
 - 4-3 Influence of the air inlet total pressure recovery
 - 4-4 Influence of the nozzle thrust coefficient
 - 4-5 Influence of air bleed
- 5 - OVERALL DIMENSIONS - WEIGHT
- 6 - INSTALLATION - HANDLING
 - 6-1 Mounting system
 - 6-2 Hoisting - Handling
- 7 - COMBUSTION TESTS

LIST OF FIGURES

- Fig. 1 Schematic view of Nord-Aviation turbofan-ramjet engine
- Fig. 2 Lengthwise cross section of the X 81 combined engine
- Fig. 3 Air inlet total pressure recovery
- Fig. 4 Maximum air capture area $Mo < 1.5$
- Fig. 5 Maximum air capture area $1 < Mo \leq 4$
- Fig. 6 Performance characteristics without afterburning $Z = 0$
- Fig. 7 Performance characteristics without afterburning $Z = 10\ 000$ feet
- Fig. 8 Performance characteristics without afterburning $Z = 20\ 000$ feet
- Fig. 9 Performance characteristics without afterburning $Z = 36\ 000$ feet
- Fig. 10 Performance characteristics with afterburning $Z = 0$
- Fig. 11 Performance characteristics with afterburning $Z = 10\ 000$ feet
- Fig. 12 Performance characteristics with afterburning $Z = 20\ 000$ feet
- Fig. 13 Performance characteristics with afterburning $Z = 36\ 000$ feet
- Fig. 14 Performance characteristics with afterburning $Z = 50\ 000$ feet
- Fig. 15 Performance characteristics with afterburning $Z = 75\ 000$ feet
- Fig. 16 Performance characteristics with afterburning $Z = 100\ 000$ feet
- Fig. 17 Influence of the air inlet total pressure recovery at $Mo = 3$
- Fig. 18 Influence of the air inlet total pressure recovery at $Mo = 4$
- Fig. 19 Influence of the nozzle coefficient and of the air bleed
- Fig. 20 Weight - Center of gravity
- Fig. 21 Mounting system
- Fig. 22 Hoisting - Handling

1 - INTRODUCTION

This study is the continuation of the previous contract (AF 61 (052) - 670) the object of which was to demonstrate the feasibility and the efficiency of the combined turbofan-ramjet engine designed by Nord-Aviation, within the range of Mach numbers from 0 to 4/4.5.

In the theoretical part of the study, three combined engines, built around three turbofans, either existing or under development (SNECMA TF 106, BRISTOL SIDDELEY PEGASUS 5, PRATT AND WHITNEY TF 33 - P7), were compared in the following fields : specific weight, overall size, performance characteristics. A calculation program was established from KEENAN AND KAYE's enthalpies tables (GAS TABLES, 1948). These tables are limited in equivalence ratios (≤ 0.5) and in temperatures ($\leq 3,500^\circ \text{R}$), the enthalpies being independent of pressure ; this simplified calculation program was however justified since the object of the study was to compare three different engines. The performance characteristics were calculated for the following flight conditions : static thrust, transonic flight at $M_0 = 1.3$, supersonic flight at $M_0 = 2.3$, subsonic flight at $M_0 = 0.8$; these performance characteristics were followed by a study of the operation range in the mixed flow configuration, and by the performance characteristics calculation in the pure ramjet configuration. The comparison was made for the same value of the following ratio : thrust at Mach 3 in the pure ramjet configuration / thrust at sea level static conditions, without afterburning, in pure turbine engine operation. A general layout for each of the three engines was given.

The experimental part was provided for :

- studying the flow velocity plot in the vicinity of the turbofan subsonic inlet in the three operating modes of the engine : pure turbofan configuration, mixed flows configuration or pure ramjet configuration.

- studying the mixture of the fan and ram flows at the fan outlet.

- studying the interaction of a non-homogeneous flow upon the performance characteristics of the common exhaust nozzle.

The specific thrusts and the specific consumptions were practically equivalent for the three combined engines studied, and the theoretical study showed the great flexibility of adaptation of the Nord-Aviation combined engine design. On the other hand, the combined engine specific weight is directly connected with the specific weight of the basic turbofan. The experimental study made it possible :

- to define a correct contour for the subsonic turbofan inlet providing the ram duct or the fan with a very satisfactory feeding throughout the engine operating range.

- to define a very efficient system for mixing of the ramjet and fan flows over a short length.

- to show the correct operation of the common exit nozzle.

The purpose of the present contract, AP 61 (052) - 750, is to continue demonstrating the feasibility and efficiency of the Nord-Aviation combined turbo-ramjet engine.

The object of the theoretical part is to establish a complete performance characteristics plot for the X 81 combined engine built around the SNECMA TP 106 turbofan which was chosen at the issue of the previous study. A new and very complete calculation program was framed for this study ; this program takes into account the effects of the burnt gases dissociation inside the exit nozzle and allows the use of component efficiencies, obtained from tests ; a sub-program calculates the thermodynamic functions of the $AIR/C_n H_{2n}$ system for all equivalence ratios and pressures, with the temperatures reaching up to 9 000° R.

All the test results obtained under cover of the previous contract are introduced in the performance characteristics

calculations. The combustion efficiencies and the head losses of the combustion system were evaluated by relying on Nord-Aviation 's experience about the ramjet combustion chambers. (The combustion system tests were in progress at the time of the performance characteristics calculations) ; the concordance between these evaluations and the results obtained during the combustion tests is excellent.

The chart of calculated performance characteristics comprises on the one hand, the acceleration ratings performance characteristics covering the equivalent air speed range from 300 kt to 800 kt, up to altitude as high as 100,000 feet (the maximum Mach number is equal to 4) on the other hand the reduced ratings without afterburning covering the descent, holding and subsonic cruise flight conditions. The laws of variation of the internal variable sections (fan exit area and common exit nozzle throat area) are defined. A general layout of the engine is given, specifying in particular the combustion system assembly as well as its air supply ducts.

An experimental part is devoted to the study of a combustion system over a largely extended equivalence ratio range, covering all the possible requirements up to Mach 4 and for an altitude ranging up to 100,000 feet. This investigation is carried out on a two-dimensional model representing a portion of an actual annular combustion chamber.

The tests carried out at Nord-Aviation 's Test Center of LES GATINES, with a single air supply, made it possible to define the combustion system. Later on this system was tried and improved at the Centre d'Essais des Propulseurs at SACLAY (a big Propulsion Test Center run by the Government), in an altitude and Mach number range more extended than that used at LES GATINES. The three operating modes were simulated : turbofan flow alone, turbofan-ramjet mixed flow, ramjet flow alone.

The combustion system thus defined is very satisfactory ;

its main features are : a great stability in a large equivalence ratio range : from 0.1 to 1.2. The combustion efficiencies obtained were very satisfactory, in spite of very severe test conditions : the simulated flight range corresponds to low equivalent air speed (approx. 400 kt) up to flight Mach numbers equal to 4, and altitudes on the order of 100,000 feet ; in a flight range relating to higher equivalent air speeds, the combustion system should give better efficiencies than those obtained. An additional test program would be necessary in order to explore all the possibilities of this combustion system.

2 - GENERAL DESCRIPTION

The Nord-Aviation turbofan-ramjet combined engine is essentially a co-axial arrangement of a turbofan (of the forward-fan type) with a ramjet combustion chamber, which permits to operate either in the pure turbofan configuration, or in the pure ramjet configuration or again in the turbofan-ramjet mixed configuration.

The variable geometry air inlet is common ; the flows through the engine are exhausted through a variable geometry convergent-divergent nozzle.

A part of the air flow captured by the air inlet is spilled around the fan and is mixed with the turbofan secondary air flow in an annular duct ; the resulting mixed air flow feeds a combustion chamber surrounding the turbofan rear section. The jet nozzle, fixed and short, permits to assure an afterburning of the primary flow. The fan flow annular exit is controlled by flaps, which allow operation in one of the three modes described above : pure turbofan, pure ramjet or mixed flow mode. Figure 1 illustrates schematically the various components of the combined engine, without the air inlet.

The pure turbofan operating mode is that of subsonic speeds as well as that of transonic flights at high altitudes.

The mixed flows operating mode is that of moderate supersonic flights, the pure ramjet operating mode (turbofan running slow or stopped) being that of high supersonic flights.

The performance characteristics of such a combined engine are consequently : that of the basic turbofan with and without afterburning at the subsonic and transonic speeds, and that of a ramjet at the high supersonic speeds.

In the combined engine operating mode, the range of which has an upper limit determined by the turbofan Mach number limitation, the thrust is greater than that of each of the individual engines when operating alone.

3 - DEFINITION OF THE X 81 COMBINED ENGINE

The combined engine, whose performance characteristics are presented in this report, is built around the basic section of the SNECMA TF 106 turbofan ; this is the X 81 combined engine. The TF 106 is an axial twin spool turbofan with mixed flows and a low by-pass ratio.

The geometrical definition adopted is that resulting from the study of the previous contract, AF 61 (052) 670 (see Vol. 3.1 GENERAL DIMENSIONS). The major overall dimensions were established by satisfactorily compromising between :

- a minimum space-requirement (length and largest cross-sectional area)
- a maximum efficiency of the mixer-diffuser-annular combustion chamber assembly
- a maximum efficiency in the pure ramjet configuration.

This general definition is based upon the data of a ratio between thrust at Mach 3 (pure ramjet operation, the turbofan being stopped) and sea level static thrust in the pure turbofan

configuration ; this ratio was defined for ensuring an economical cruise at Mach 3 for a supersonic transport aircraft. This ratio defines the air flow rate required for ensuring the economical flight at Mach 3, i.e. it defines the annular combustion chamber air supply ducts. The turbofan nozzle cross-section area was defined at the conclusion of a parametric study under sea level static, and transonic conditions, in order to allow afterburning of the primary flow in the pure turbofan operating mode and in the combined configuration with mixed flows, while optimizing the performance characteristics in sea level static conditions and in transonic flight.

3-1 Major dimensions

The major dimensions are as follows :

- Combined engine length (without exit nozzle)	144 in.
- " " " (with exit nozzle)	268 in.
- " " " outer diameter (combustion chamber station)	57.1 in.
- Turbofan inlet diameter	39 in.
- Combined engine inlet inner diameter	51.2 in.
- Cross-section area of the combustion chamber	12.6 sq.ft.
- Mixer throat cross section area	3.6 sq.ft.
- Turbofan nozzle exit cross section area	4 sq.ft.
- Secondary flow exit cross section area (at the exit of the guide vanes)	2.1 sq.ft.
- Turbofan outer cross section area at the level of the turbine flange	5.1 sq.ft.

Fig. 2 represents a general layout of the X 81 combined engine at the scale of 1/10 size.

3-2 Structure

The X 81 combined engine is divided into two major parts.

- The front section, consisting of the basic section of the TF 106 turbofan, the annular combustion chamber air supply ducts, the secondary and ramjet air flows mixing system with its controls, the annular and primary combustion systems with their supply circuits.
- The rear section, consisting of the combustion chamber and of the variable geometry exit nozzle.

The junction plane of these two sections is ahead of the turbofan nozzle exit ; this permits clearing the annular combustion system external flame holders, as well as those of the primary combustion system at the separation between the front and the rear parts.

3-2-1 Front section

The general design of the basic turbofan is retained ; the structural assembly consisting of the fan exit guide vanes is extended radially by a series of rigid arms meant for attaching the direct air supply duct ; the variable position flaps of the mixing system, with their associated controls, are fixed on this rigid assembly.

A system of links, existing on the basic turbofan and adapted to the combined engine, placed at the level of the turbine inlet, allows the attachment of the annular duct outer casing and also allows the longitudinal and radial expansion of the gas generator. This links system transmits directly the transverse stresses. A strong outer frame is placed at this level, it carries the engine major mountings ; the longitudinal stresses of the gas generator are conveyed to the major mountings by the rigid assembly at the fan exit, and by the annular duct outer casing.

At the front end, the direct air supply duct is held by a system of links connected to the fan casing.

The air supply duct structure is made of a thin sheet reinforced through transversal corrugations ; this outer skin is flanged at the front end with a frame ensuring tightness with the air inlet diffuser ; two main frames assure the rigidity of this envelope : the front main frame at the level of the fan exit, and the main frame in close proximity to the turbines, carrying the powerplant main mountings.

The annular combustion system is attached to this duct, upstream the main mountings frame with an articulation point on the turbofan jet nozzle, allowing expansion.

The afterburner system is attached to the exit cone of the turbofan, with a flexible connection articulated on the annular system.

The ancillary equipment necessary for the operation of the turbofan and the combined engine is placed outside the duct : accessory gear box, oil tank, pumps, coolers, fuel system regulators, etc.

Drawing 8-1/1 represents a scale 1/2 size, detailed, lengthwise cross section of the combined engine front part.

3-2-2 Rear section

The combustion chamber is composed of an external cylindrical envelope and of a two-part protection ring assembly.

The external envelope ends in an important frame which takes the attachment fittings of the variable geometry exit nozzle. An intermediate frame takes the attachment fittings of the flap control rams of the exit nozzle.

Internally, the envelope is fitted with two-part protection rings. These rings are rigidly fixed at both ends of combustion chamber and guided over their overlap by locator pins and springs that allow a certain degree of freedom, compatible with the thermal expansion.

The convergent-divergent exit nozzle with variable geometry comprises two groups of movable flaps. The kinematics is provided for modifying the configuration from simple convergent to convergent-divergent and vice versa. These modifications are obtained by means of two circular frames sliding on six slides connected to four groups of rams. During their displacement, the rear flaps actuate mobile caps that shut off the pressurized compartment comprised between the flaps and the outer skin ; the purpose of this compartment is to stop the ingress of hot gases, and to assure the cooling of flaps.

3-3 Control system

The fuel control of the gas generator can be retained. This control system keeps the turbine inlet temperature at the value set in by the pilot. The regulator determines the corresponding fuel flow to be injected in the turbofan combustion chamber.

The afterburning fuel control determines the fuel flow to be injected in the primary flow and in the annular flow, in terms of the exit nozzle cross-section area which is controlled by the pilot, while maintaining the gas generator at the selected operation rating.

4 - PERFORMANCE CHARACTERISTICS

All the performance characteristics, with and without afterburning are calculated :

- for standard atmospheric conditions
- with a "low" heating value of 18,630 BTU/lb (10 350 k. cal/kg)
- without air-bleed or power off-take
- with a total pressure recovery law for the air inlet defined on Fig. 3, i.e.
 - . $P_1/P_0 = 1$ in subsonic flight
 - . $P_1/P_0 = 1 - 0.075 (M_0 - 1)^{1.35}$ in supersonic flight(specification MIL - E - 5008 B)
- with the exit nozzle in the "simple convergent" configuration up to $M_0 = 1.3$, and "convergent-divergent" for $M_0 > 1.3$, and, in the latter case with a nozzle coefficient equal to 0.98.

4-1 Static thrust Performance characteristics

RATINGS	AIR FLOWRATE lb/sec	THRUST lb	S.F.C. lb/lb.hr
With afterburning	237		
- $T_8 = 3\ 600\ ^\circ R$		21,400	2.275
- $T_8 = 2\ 700\ ^\circ R$		18,400	1.705
Without afterburning			
- Maximum rating	235	11,500	0.585

4-2 Flight performance characteristics

4-2-1 Air mass flow

The maximum air mass flow entering the engine is determined by means of Fig. 4 and 5 which give the maximum air capture area at the upstream infinite, A_0 .

Fig. 4 gives the maximum air mass flow in terms of altitude ($0 \leq Z \leq 80\ 000$ ft) and of the flight Mach number M_0 ($M_0 < 1.5$). Afterburning has a small influence over the engine air mass flow, the variation is less than 2,5 %.

Fig. 5 gives the maximum engine air mass flow for altitudes varying from 36 000 ft to 100 000 ft and for flight Mach numbers comprised between 1 and 4. The graph is plotted for an afterburning temperature equal to 1 600 °R; the air mass flow in the pure ramjet operation ($M_0 > 2.5$) is not affected by the afterburning. The air stream tube was limited to the cross-section area at the largest diameter of the engine; this point is reached in the vicinity of Mach 3.05.

4-2-2 Performance characteristics without afterburning

The general performance characteristics of the engine without afterburning are illustrated on Fig. 6, 7, 8 and 9, under the form :

$SPC = f(F)$; the flight Mach number and the ratio TIT/TIT_{max} (turbine inlet temperature / maximum turbine inlet temperature) are shown as parameters.

These performance characteristics are given for the following altitudes :

0 10 000 20 000 36 000 ft.

These performance characteristics are calculated for the pure turbofan operating mode.

4-2-3 Performance characteristics with afterburning

These performance characteristics cover, the Mach number range from sea level static conditions to Mach 4, for altitudes varying from 0 to 100 000 ft. It comprises the three operating modes of the engine : pure turbofan mode, combined engine mode and pure ramjet mode. For the first two modes, the performance characteristics calculation is made at the maximum rating of the turbofan ; for the third mode, the turbofan is stopped.

The performance characteristics are given under the form :

$F = f(M_0)$; the specific fuel consumption (SFC) and the afterburning temperature (T_8) are shown as parameters. They are calculated for the following altitudes :

Z = 0	Fig. 10
Z = 10 000 ft	Fig. 11
Z = 20 000 ft	Fig. 12
Z = 36 000 ft	Fig. 13
Z = 50 000 ft	Fig. 14
Z = 75 000 ft	Fig. 15
Z = 100 000 ft	Fig. 16

4-3 Influence of the air inlet total pressure recovery

A relative variation of the air inlet total pressure recovery, $d P_1/P_0$ entails a relative variation of the thrust

$$\frac{dF}{F}$$

and of the specific fuel consumption $dSFC/SFC$. Fig. 17 and 18 show these variations for flight Mach numbers 3 and 4 in terms of the afterburning temperature, T_8 .

For Mach 3, the variations are calculated in assuming that the velocity of the internal air flow is retained; the air capture area at the upstream infinite is then proportionate to the total pressure recovery, P_1/P_0 .

For Mach 4, the variations are calculated in assuming that the air capture area at the upstream infinite is constant; a reduction of the total pressure recovery ratio increases the internal flow velocity.

4-4 Influence of the nozzle coefficient

In supersonic flight ($M_0 > 1.3$) the general performance characteristics are calculated with the exit nozzle in the convergent-divergent configuration. The expansion is assumed to be complete, the gross thrust thus obtained is affected with a nozzle coefficient φ made equal to 0.98.

Fig. 19, shows the relative variations of the thrust dF/F and of the specific fuel consumption $dSFC/SFC$ in terms of the relative variations of the nozzle coefficient, $d\varphi/\varphi$, and of the afterburning temperature T_8 .

4-5 Influence of the air bleed

Air can be bled for the ancillaries from the annular airflow in the diffuser. The influence of this air bleed, μ , over the performance characteristics during supersonic flights is shown on Fig. 19, μ being equal to the ratio between the bleed air flow and the annular air flow.

5 - OVERALL DIMENSIONS - WEIGHT

The overall size of the combined engine together with the exit nozzle is shown on drawing 8-1/2.

The weights and centers of gravity of the complete engine with a standard equipment are given on Fig. 20, but the ingredients contained in the engine systems are not included.

The total weight breaks down as follows :

- Turbofan : dry section without the outer envelope of the annular duct	+ afterburning system	
	+ turbofan standard equipment	2 350 lb
- Mixer system :		
	Flaps, control items	
	Actuators	232 lb
- Annular combustion system :		
	With attachment and pipes	246 lb
- Outer envelope and fan fairing :		
	Structure included	462 lb
- Combined engine equipment		110 lb
	<u>WEIGHT OF THE FRONT SECTION</u>	<u>3 400 lb</u>
- Combustion chamber		
	Protection rings included	298 lb
- Exit nozzle		
	Actuators and structure included	1 369 lb
	<u>WEIGHT OF THE REAR SECTION</u>	<u>1 667 lb</u>
	<u>TOTAL WEIGHT OF THE ENGINE</u>	<u>5 067 lb</u>

6 - INSTALLATION - HANDLING

6-1 Mounting system

Two mounting plans are provided on each side of the center of gravity.

The main mounting plan is situated on the second main frame of the front section outer envelope.

The secondary mounting plan is located on the combustion chamber rear frame which takes the exit nozzle attachment fittings.

Fig. 21, shows the typical mounting cases which must be conceived to allow for the free expansion of casings. Drawing 8-1/3 gives a detailed view of the attachment points.

6-2 Hoisting - Handling

A certain number of hoisting points are provided for, they allow ground handling of the complete engine or of the various constituents of the propulsion system.

The locations of these hoisting points are illustrated on Fig. 22. Drawing 8-1/4 shows a detailed view of these points.

7 - COMBUSTION TESTS

The combustion tests resulted in the definition of a combustion system having excellent operating characteristics within the very severe flight range investigated : the test conditions correspond to flights at low equivalent air speeds (~ 400 kt) i.e. flights at very high altitudes. This system was tried up to Mach 4, for an altitude close to 100 000 ft.

The three operation modes have been simulated ; ramjet flow alone, turbofan flow alone, turbofan and ramjet flows.

The table herebelow gives the combustion efficiencies

obtained during the tests, in conditions corresponding to a flight at an equivalent air speed of 400 kt, at maximum thrust rating, and compares the figures obtained with those used in the calculations for the performance characteristics.

Flight Mach number	Altitude	Combustion efficiency	
		Tests	Calculations
1.5	50 000	0.65	0.77
2	63 000	0.80	0.80
2.5	73 500	0.86	0.855
3	81 500	0.91	0.89
3.5	88 500	0.92	0.91
4	94 000	0.95	0.92

The agreement between the test results and the efficiency evaluations used in the calculations for the performance characteristics are excellent, these evaluations were based on the Nord-Aviation experience in the field of ramjet combustion chambers.

It should be noted that an improvement of the combustion efficiencies could be obtained in the zone of rich equivalence ratios by modifying the distributor and the external injection grids, as well as in the zones where the equivalence ratios are very lean by adapting the fuel injection pressures to the small fuel flows required. In addition, this combustion system tried under less severe conditions - corresponding to flights at higher conventional speeds, i.e. flights at lower altitudes - can only give better efficiencies than those obtained up to now.

This combustion system is characterized by its very great stability over a widely extended equivalence ratio operating

0

0

()

range (0.1 to 1.2).

()

Also it appears that the actual head losses are very close to the figures used in the calculations.

()

To sum up, these tests have enabled us to develop a full scale combustion system showing good efficiencies in very severe conditions and over a very wide operating range, from Mach 0 to Mach 4.

()

()

()

()

()

()

()

()

()

()

()

()

()

()

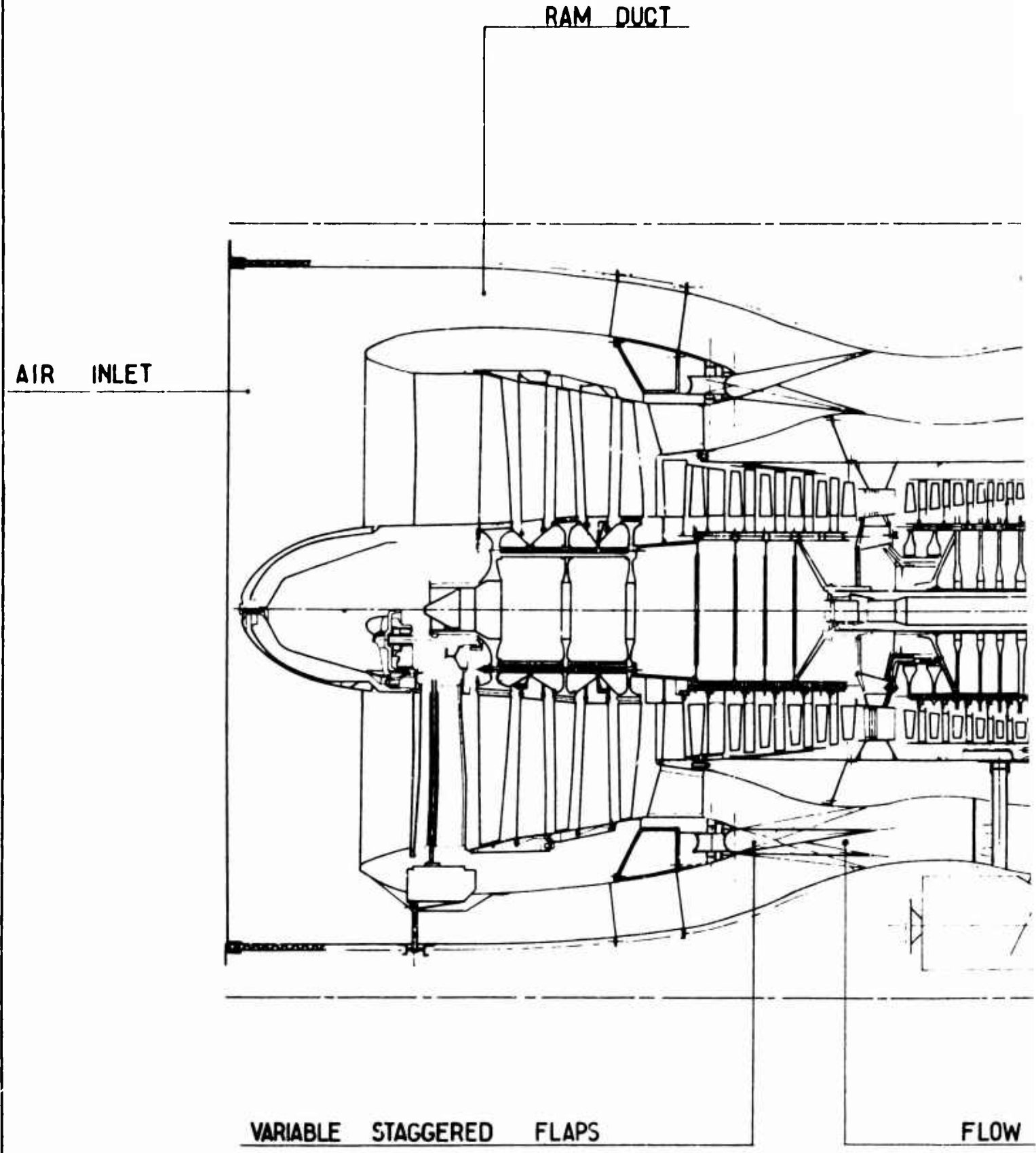

COMBUSTION SYSTEM

PILOT BURNER

FLAME

FLOW MIXER

DIFFUSER

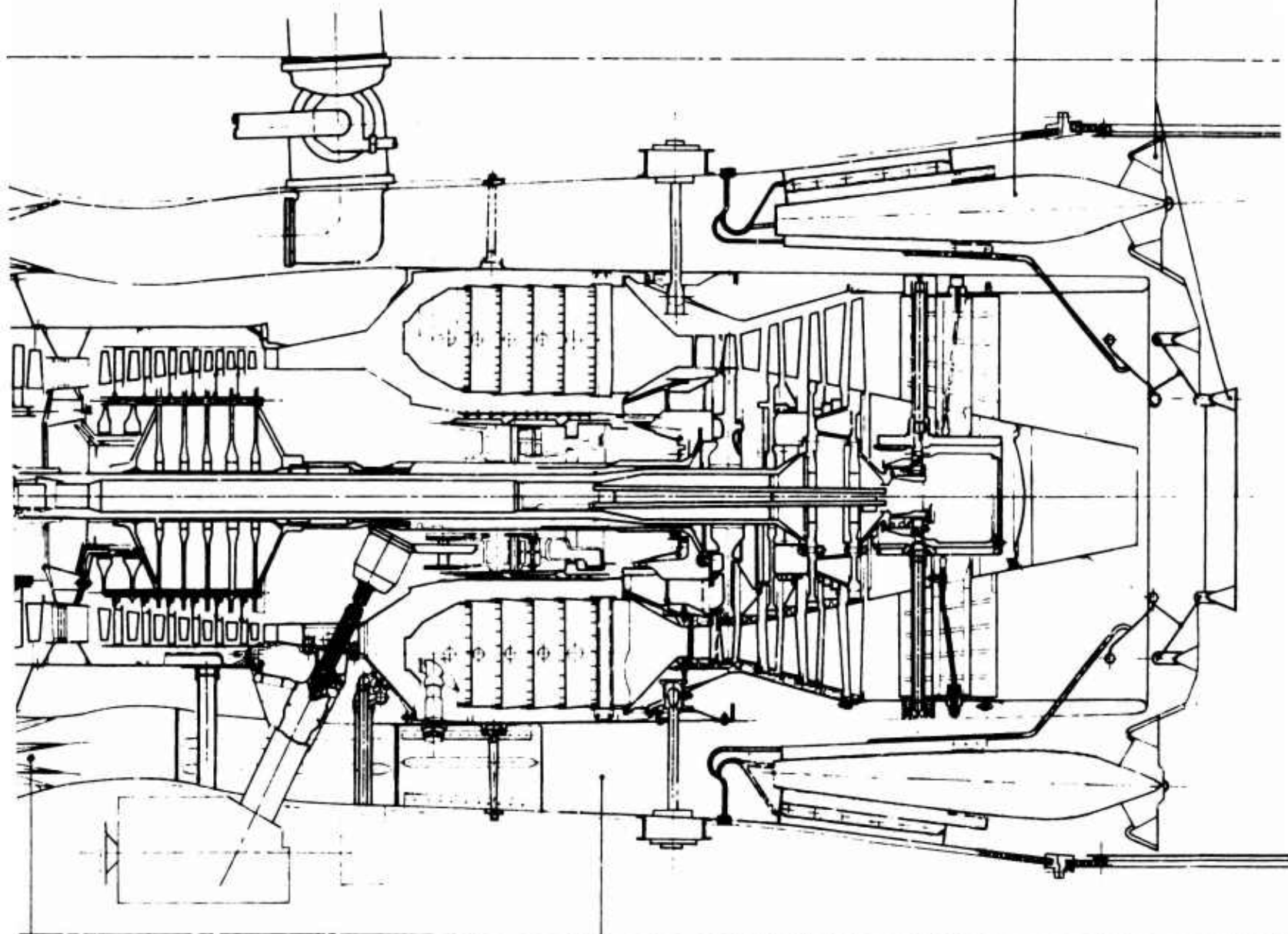

COMBUSTION SYSTEM

BURNER

FLAME HOLDERS

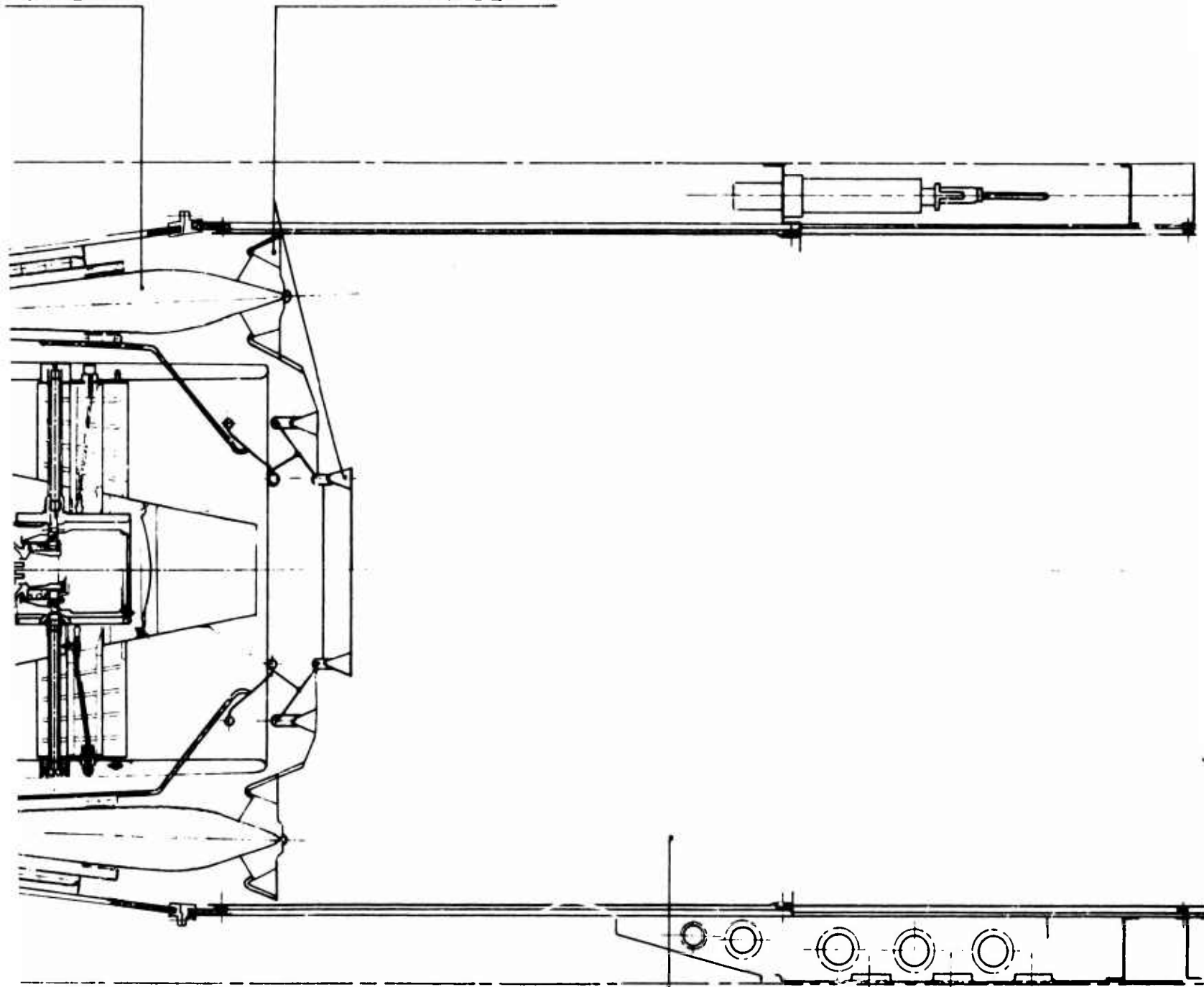

COMBUSTION CHAMBER

VARIABLE EXIT NOZZLE

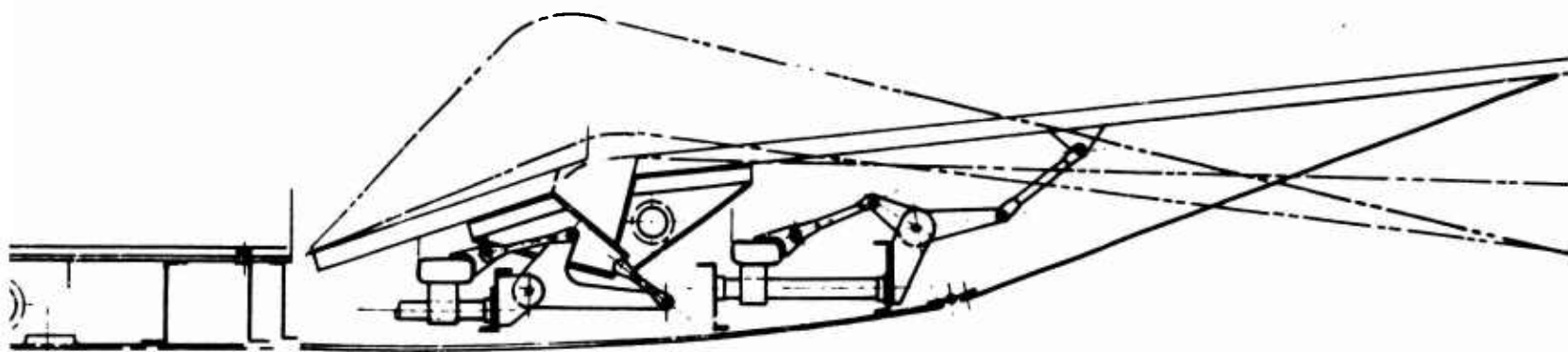
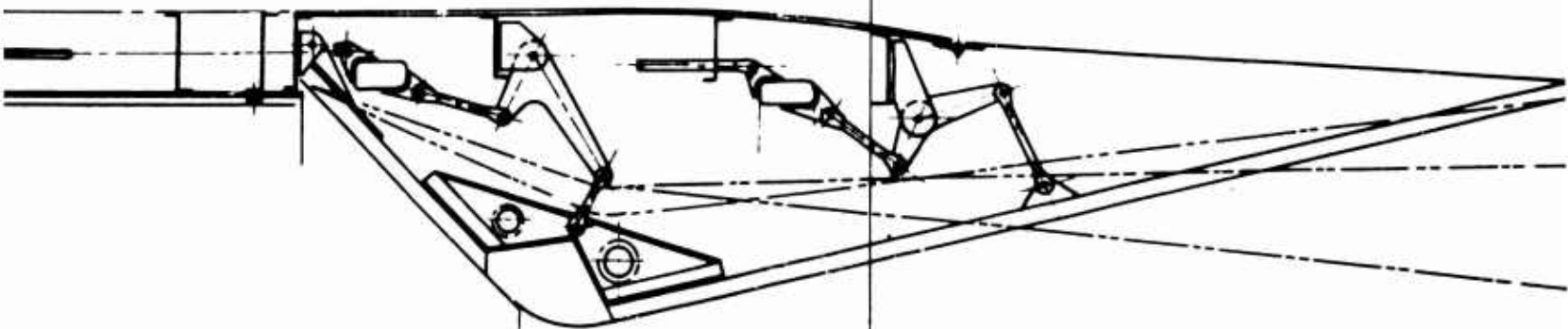

5147/NIOBE IV/29/2

Fig: 2

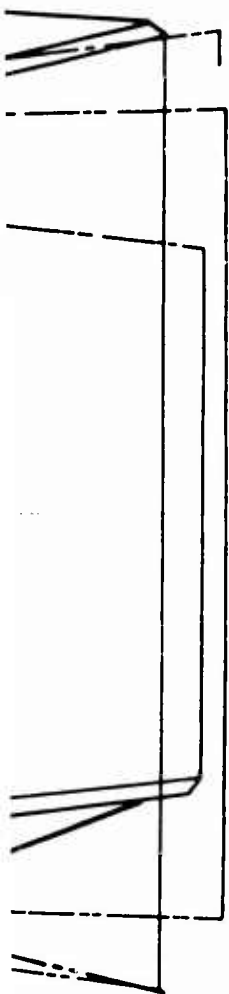

15

X 81 TURBOFAN - RAMJET ENGINE

NORD
AVIATION

LENGTHWISE CROSS-SECTION

Scale 1/10

DOC. NT 1 LA 1 'RIÉT. E N AV. 3N
 IL NE PEUT ÊTRE UTILISÉ, REPRODUIT OU COMMUNIQUÉ
 SANS SON AUTORISATION

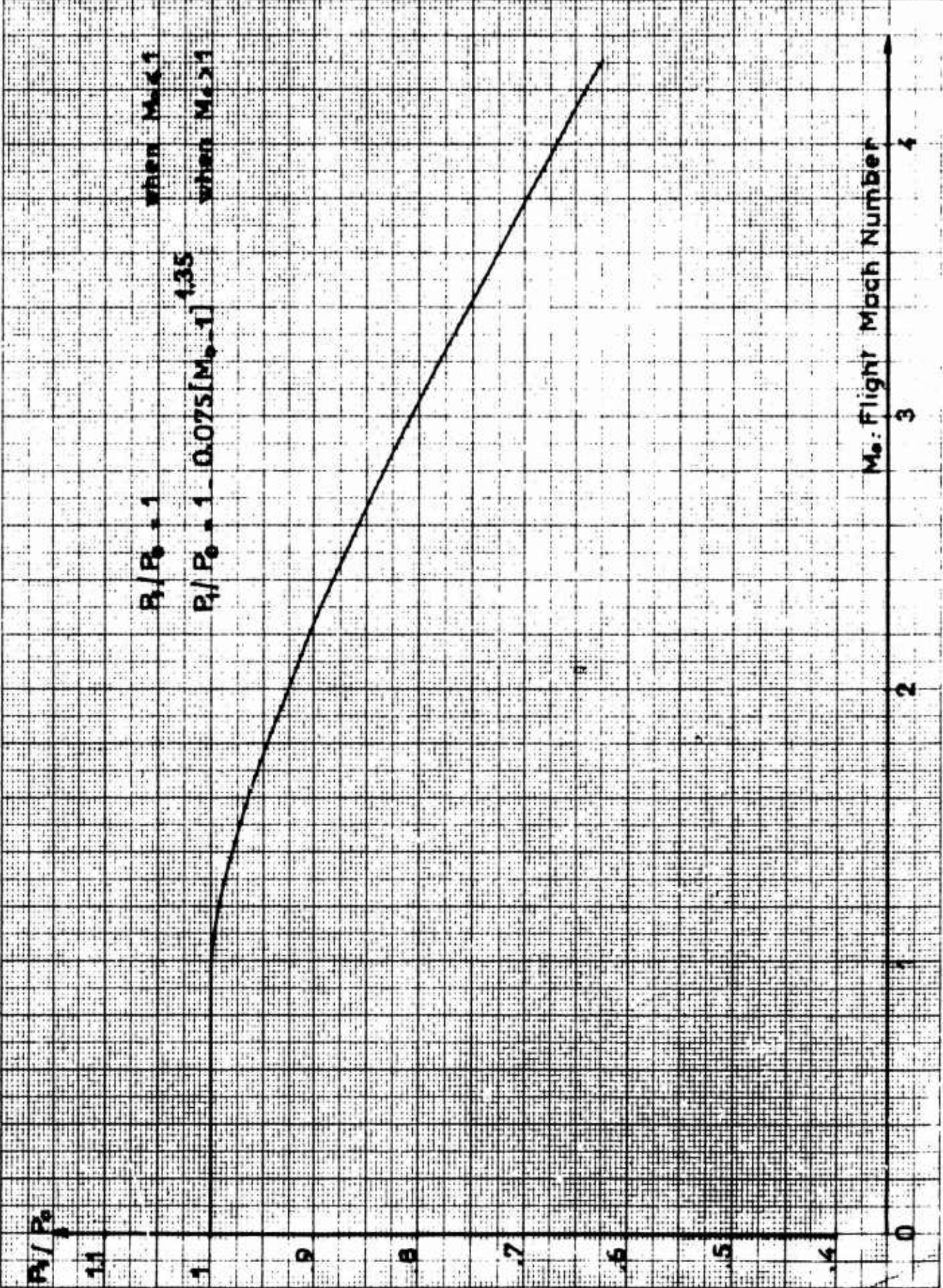

Nord-Aviation	MAXIMUM AIR CAPTURE AREA	5147/NIOBE IV /29/Z
	AFTERBURNING INFLUENCE	Figure 4

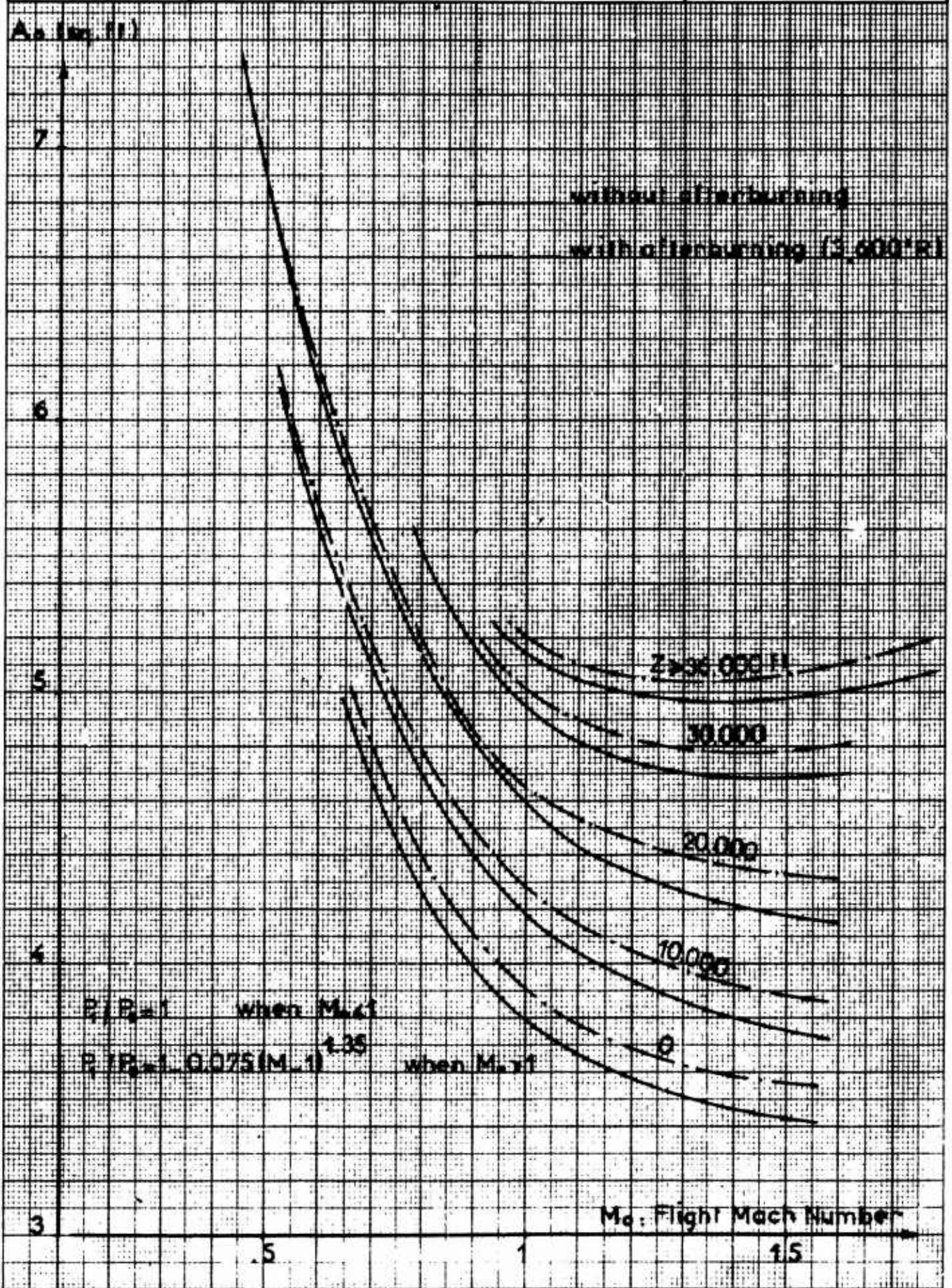

Ce document est la propriété de la Nord Aviation
 Il ne peut être utilisé, reproduit ou communiqué
 sans son autorisation

DOCUMENT LA PROPRIÉTÉ DE NORD AVIATION
 IL NE PEUT ÊTRE UTILISÉ, REPRODUIT OU COMMUNIQUÉ
 SANS SON AUTORISATION

Nord-Aviation	MAXIMUM AIR CAPTURE AREA	5147/NIOBE IV/29/Z
		Figure 5

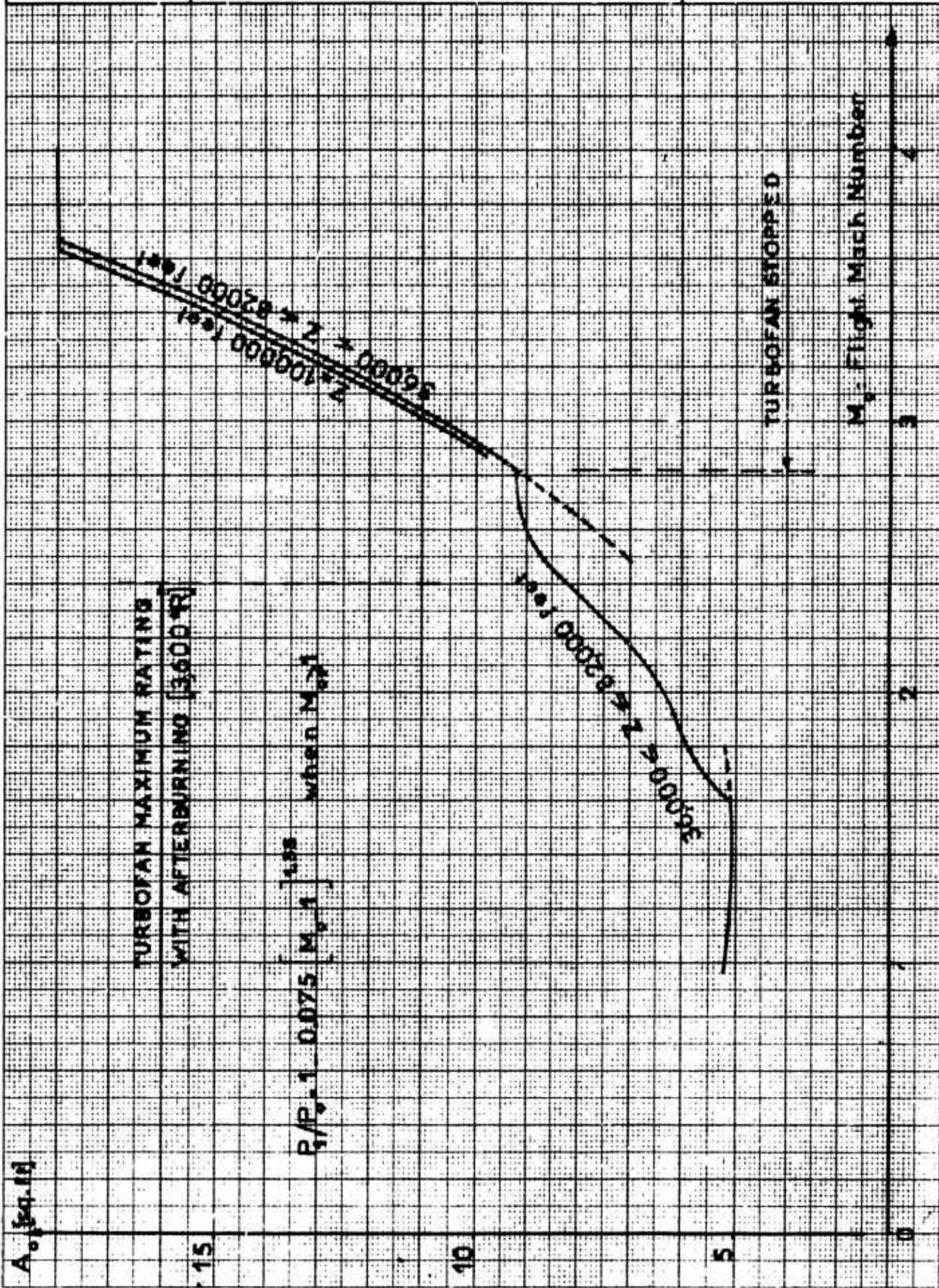

Nord-Aviation

X 81 TURBOFAN RAMJET ENGINE
THRUST AND S.F.C. AT SEA LEVEL
WITHOUT AFTERBURNING

5147/NIOBE IV/29/Z

Figure 6

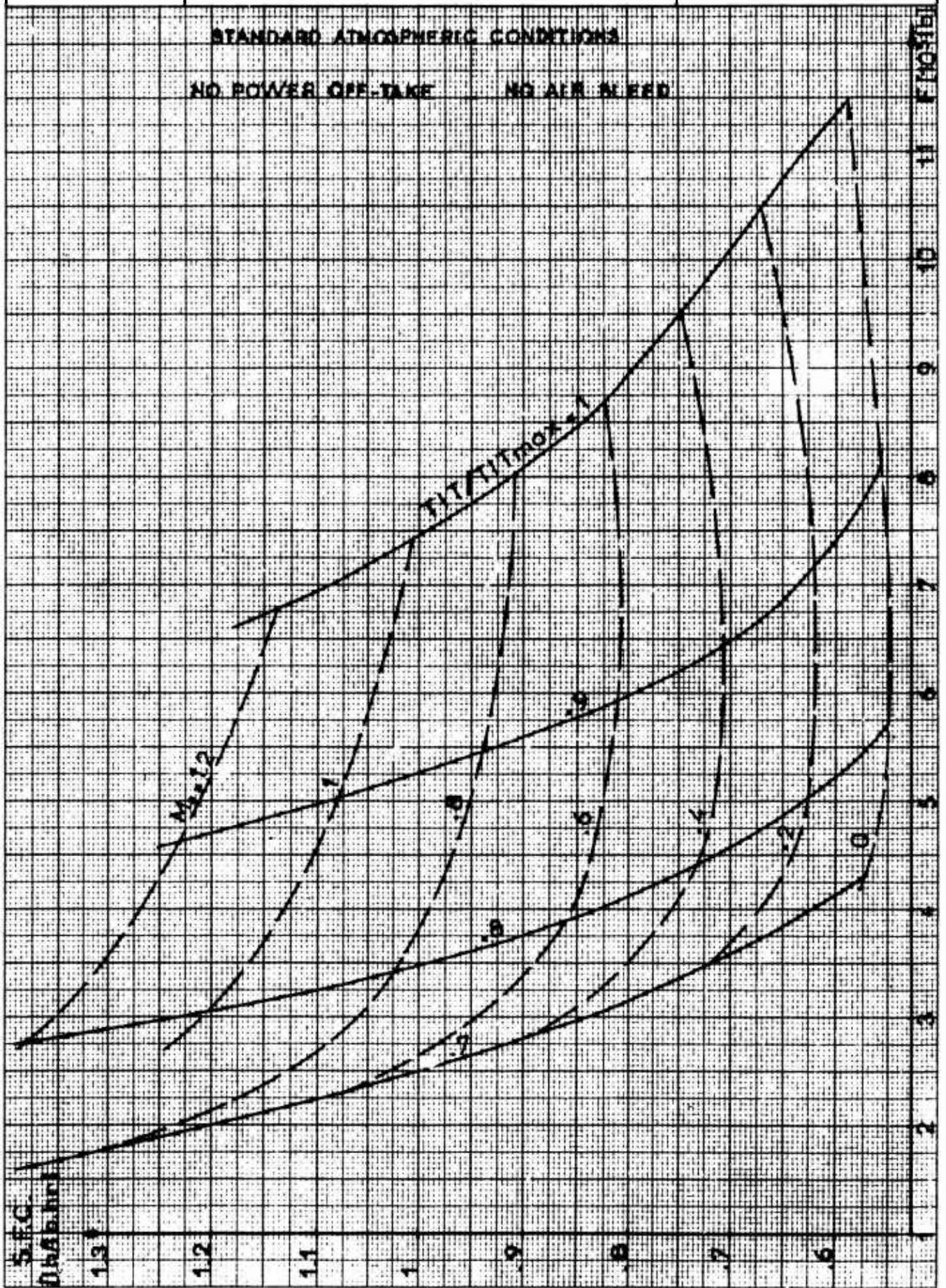

DOCUMENT EST LA PROPRIÉTÉ DE NORD AVIATION
IL NE PEUT ÊTRE UTILISÉ, REPRODUIT OU COMMUNIQUÉ
SANS SON AUTORISATION

Nord-Aviation

X 81 TURBOFAN-RAMJET ENGINE
THRUST AND S.F.C. AT 10,000 feet
WITHOUT AFTERBURNING

5147/NIOBE IV/29/Z

Figure 7

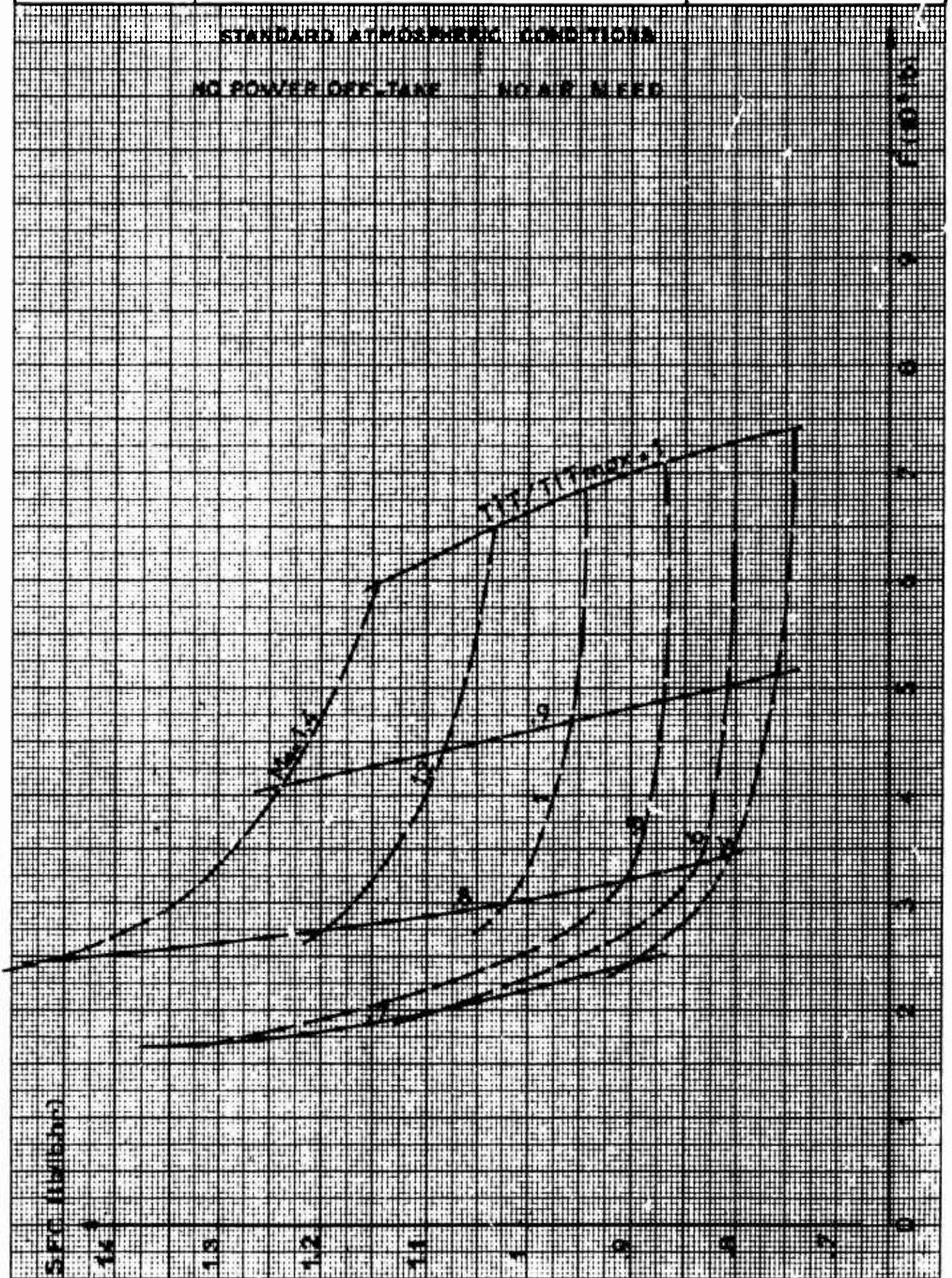

DOCUMENT LA PROPRIÉTÉ DE NORD AVIATION
IL NE PEUT ÊTRE UTILISÉ, REPRODUIT OU COMMUNIQUÉ
SANS SON AUTORISATION

Nord-Aviation

X 81 TURBOFAN-RAMJET ENGINE

5147/NIOBE IV/29/Z

THRUST AND SEC. AT 20,000 feet
WITHOUT AFTERBURNING

Figure 8

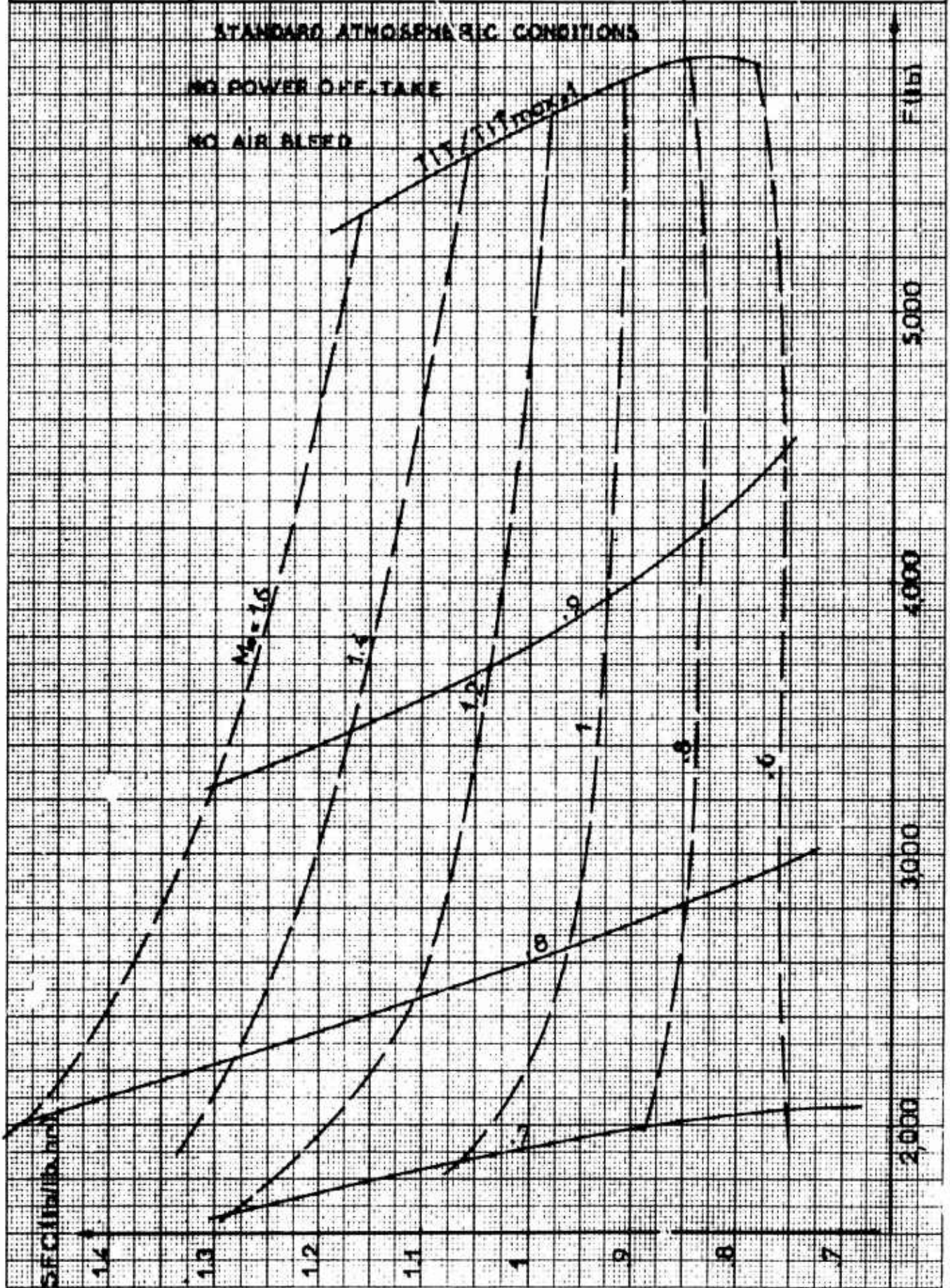

DOCUMENT DE LA SOCIÉTÉ DE NORD AVIATION
IL NE PEUT ÊTRE UTILISÉ, REPRODUIT OU COMMUNIQUÉ
SANS SON AUTORISATION

Nord-Aviation	X 81 TURBOFAN-RAMJET ENGINE	5147/NIOBE IV/29/Z
	THRUST AND SFC. AT 36000 feet WITHOUT AFTERBURNING	Figure 9



Document est la propriété de Nord Aviation
Il ne peut être utilisé, reproduit ou communiqué
sans son autorisation

Nord-Aviation

X81 TURBOFAN-RAMJET ENGINE
THRUST AND S.F.C. AT SEA LEVEL
WITH VARIABLE AFTERBURNING

5147/NIOBE IV/29/Z

Figure 10

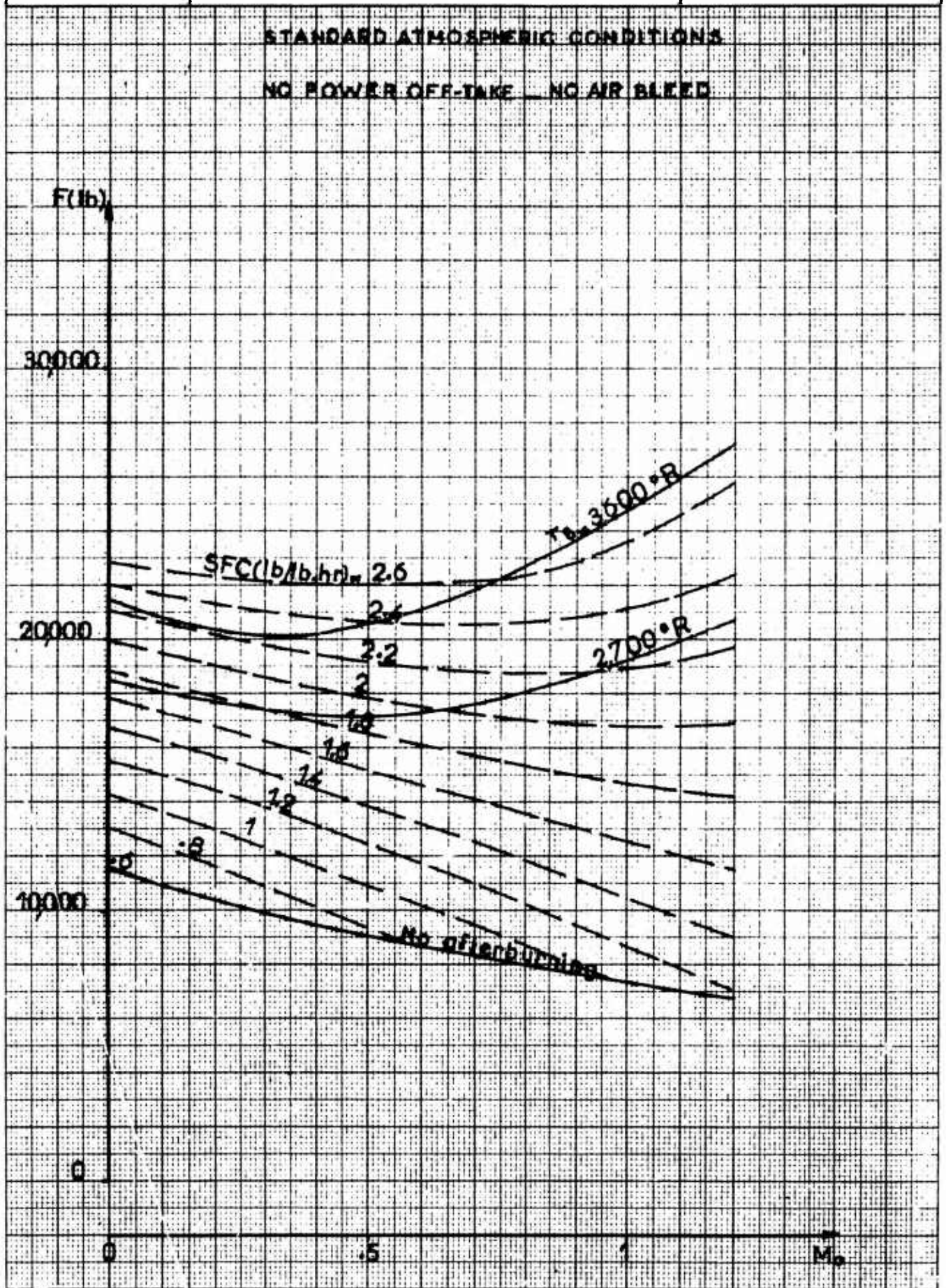

LE DOCUMENT EST LA PROPRIÉTÉ DE NORD AVIATION
IL NE PEUT ÊTRE UTILISÉ, REPRODUIT OU COMMUNIQUÉ
SANS SON AUTORISATION

Nord-Aviation	X81 TURBOFAN-RAMJET ENGINE	5147/NIOBE IV/29/Z
	THRUST AND S.F.C. AT 10,000 feet WITH VARIABLE AFTERBURNING	Figure 11

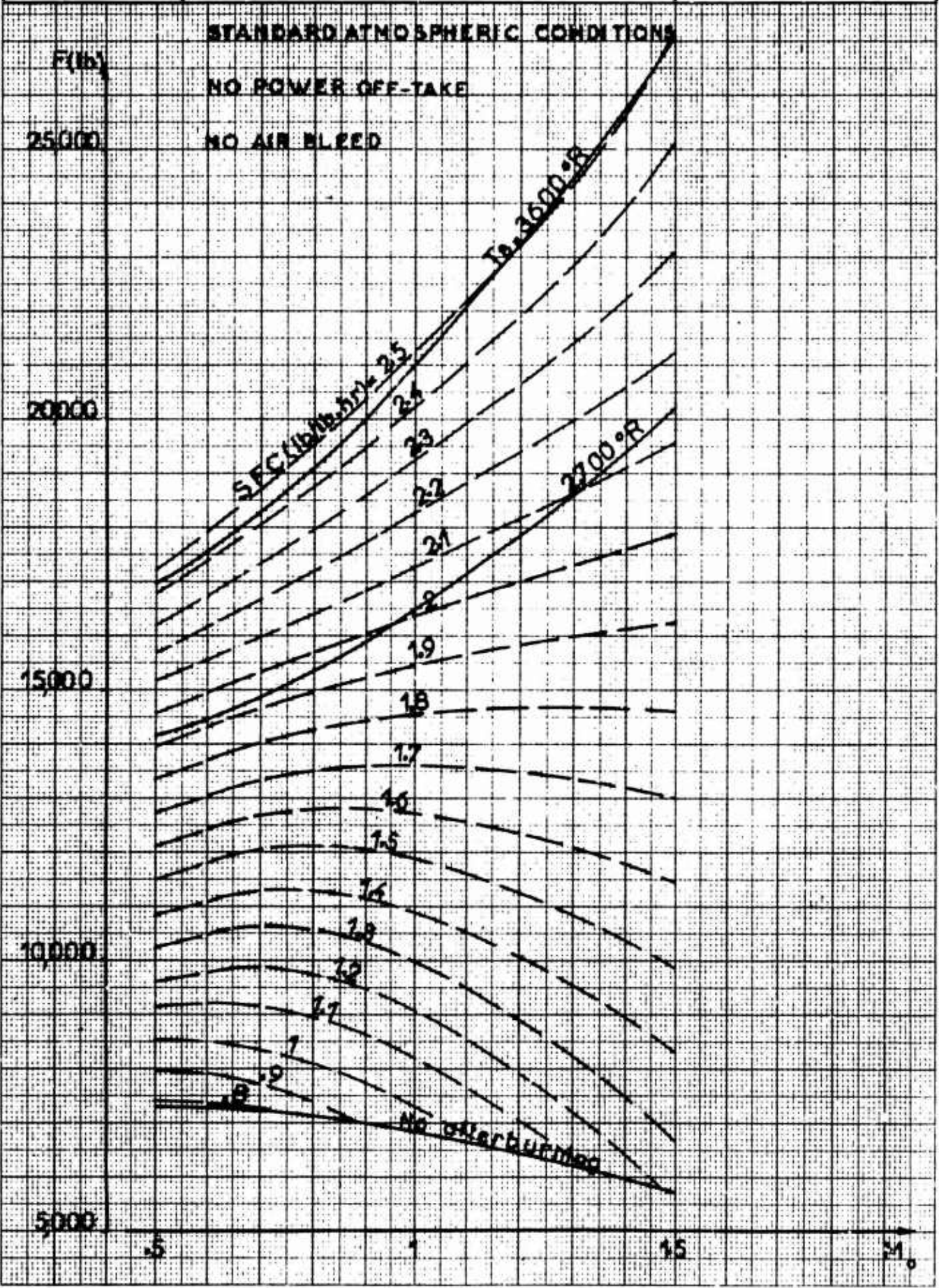

64-101-01
 DOCLANT LA PRIÉTÉ DE N. A. V. JN
 IL NE PEUT ÊTRE UTILISÉ, REPRODUIT NI COMMUNIQUÉ
 SANS SON AUTORISATION

Nord-Aviation

X 81 TURBOFAN-RAMJET ENGINE
THRUST AND S.F.C. AT 20000 feet
WITH VARIABLE AFTERBURNING

5147/NIOBE IV/29/Z

Figure 12

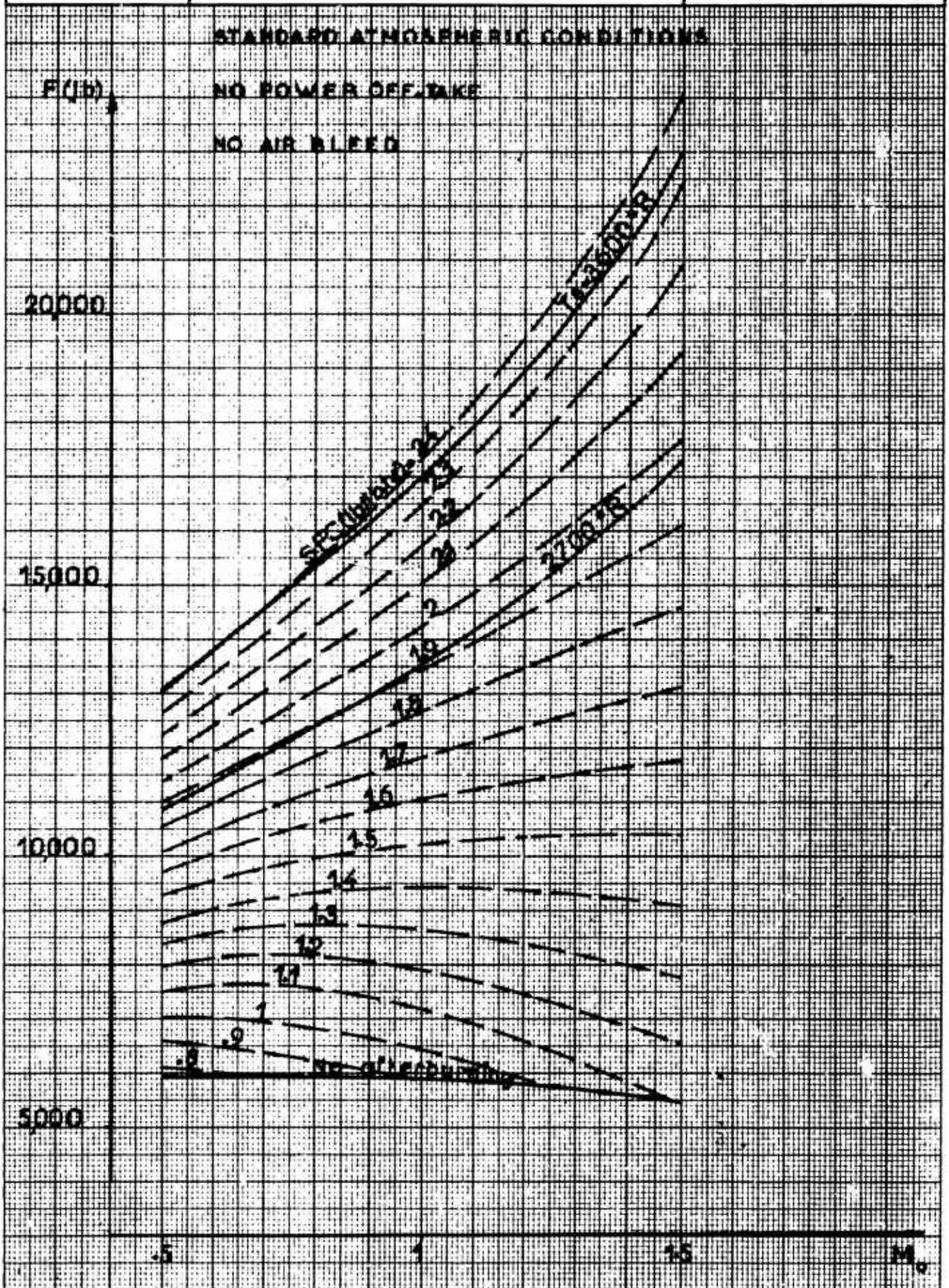

6-21-57
LE DOCUMENT EST LA PROPRIÉTÉ DE NORD AVIATION
IL NE PEUT ÊTRE UTILISÉ, REPRODUIT OU COMMUNIQUÉ
SANS SON AUTORISATION

Nord-Aviation	X81 TURBOFAN-RAMJET ENGINE	5147/NIOBE IV/29/Z
	THRUST AND S.F.C. AT 36,000 feet WITH VARIABLE AFTERBURNING	Figure 13

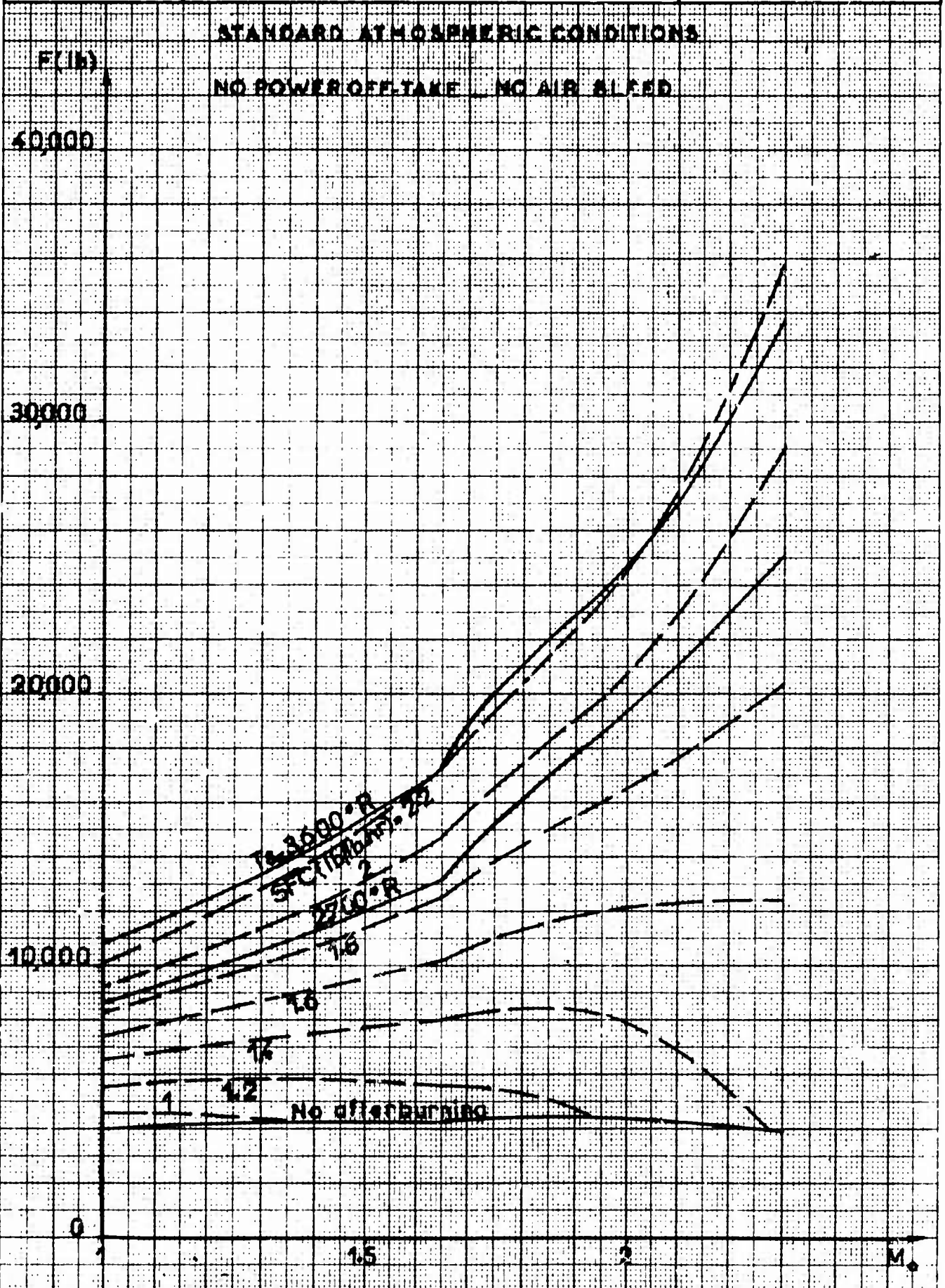

DOCUMENT LA FRIÈRE INC. AVL 74
 IL NE PEUT ÊTRE UTILISÉ, REPRODUIT OU COMMUNIQUÉ
 SANS SON AUTORISATION

Nord-Aviation

X 81 TURBOFAN-RAMJET ENGINE
THRUST AND S.F.C. AT 5000 feet
WITH VARIABLE AFTERBURNING

5147/NI0BEIV/29/2

Figure 14

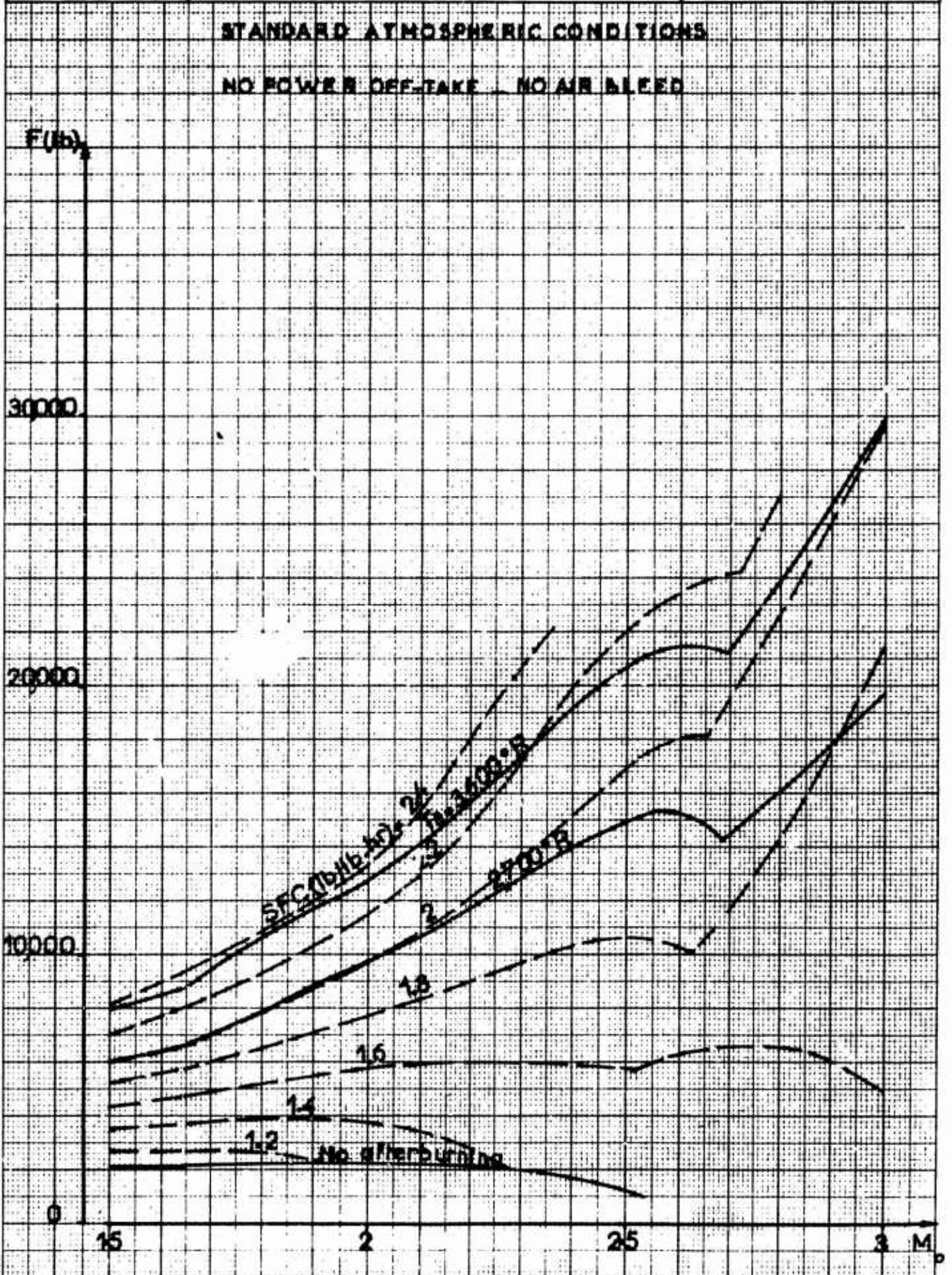

641 000

IL NE PEUT ÊTRE UTILISÉ, REPRODUIT OU COMMUNIQUÉ
SANS SON AUTORISATION

Nord-Aviation	X81 TURBOFAN-RAMJET ENGINE	5147/NI0BE IV/29/Z
	THRUST AND S.F.C. AT 75000 feet WITH VARIABLE AFTERBURNING	Figure 15

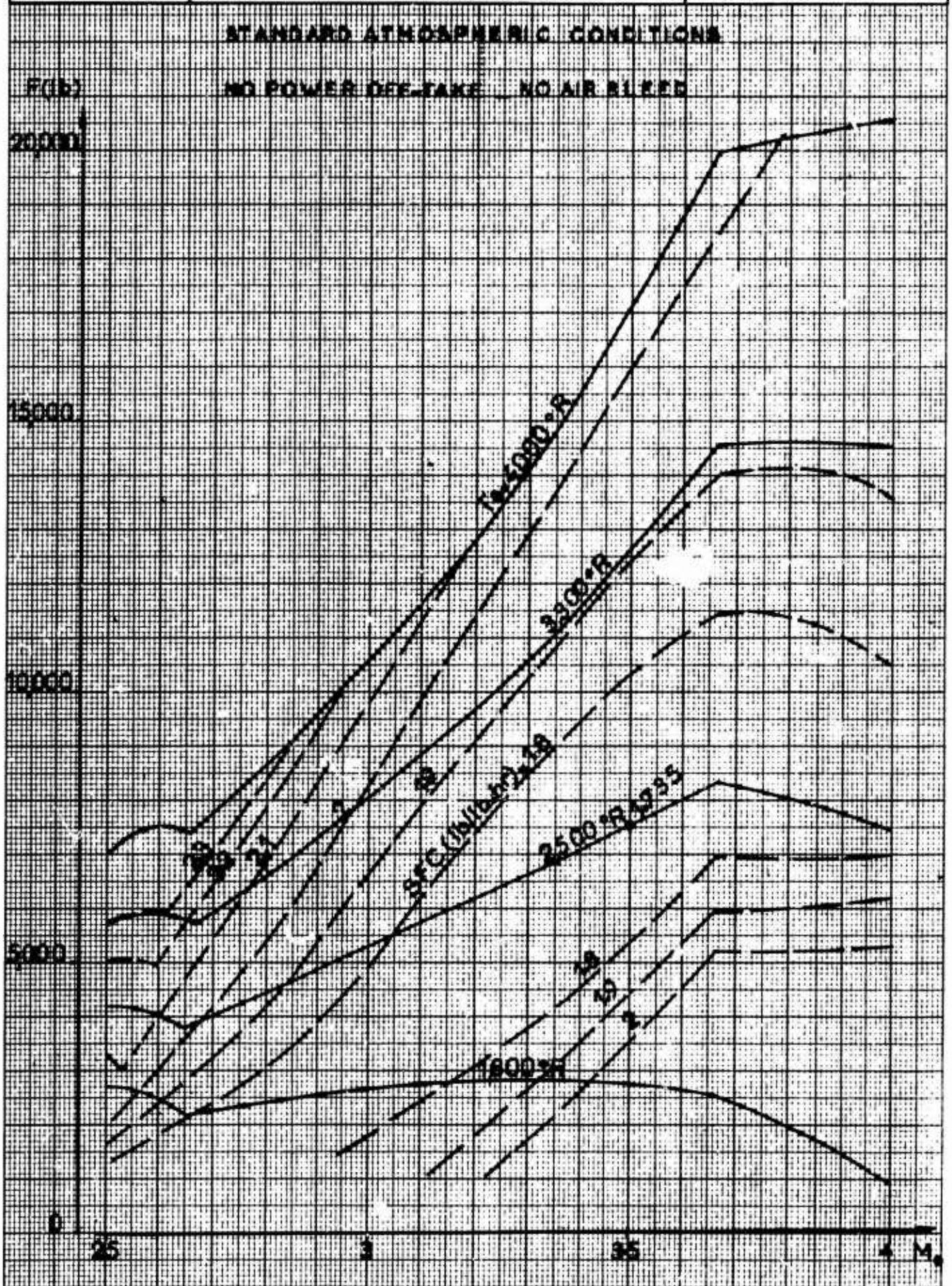

Ref. 0057

DOCU ET LA RIÉTI : M. AVI N
IL NE PEUT ÊTRE UTILISÉ, REPRODUIT OU COMMUNIQUÉ
SANS SON AUTORISATION

Nord-Aviation

X 81 TURBOFAN-RAMJET ENGINE
THRUST AND SFC AT 100,000 feet
WITH VARIABLE AFTERBURNING

5147/NIOBE IV/29/Z

Figure 16

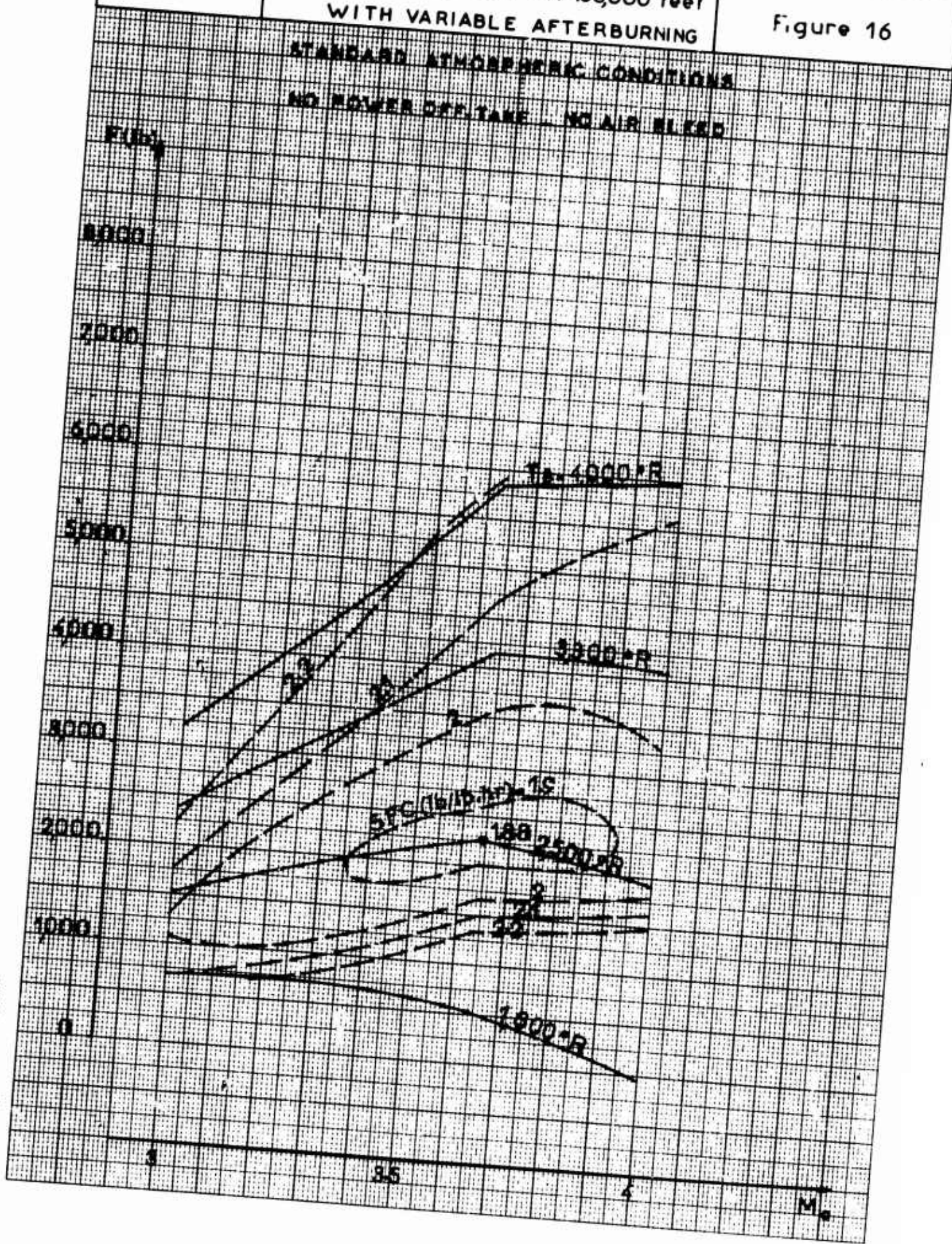

Doc. NT. LA. PRIET. E. N. AV. 3N
IL NE PEUT ÊTRE UTILISÉ, REPRODUIT OU COMMUNIQUÉ
SANS SON AUTORISATION

DOCUMENT LA SOCIÉTÉ NORD AVIATION
 IL NE PEUT ÊTRE UTILISÉ, REPRODUIT OU COMMUNIQUÉ
 SANS SON AUTORISATION

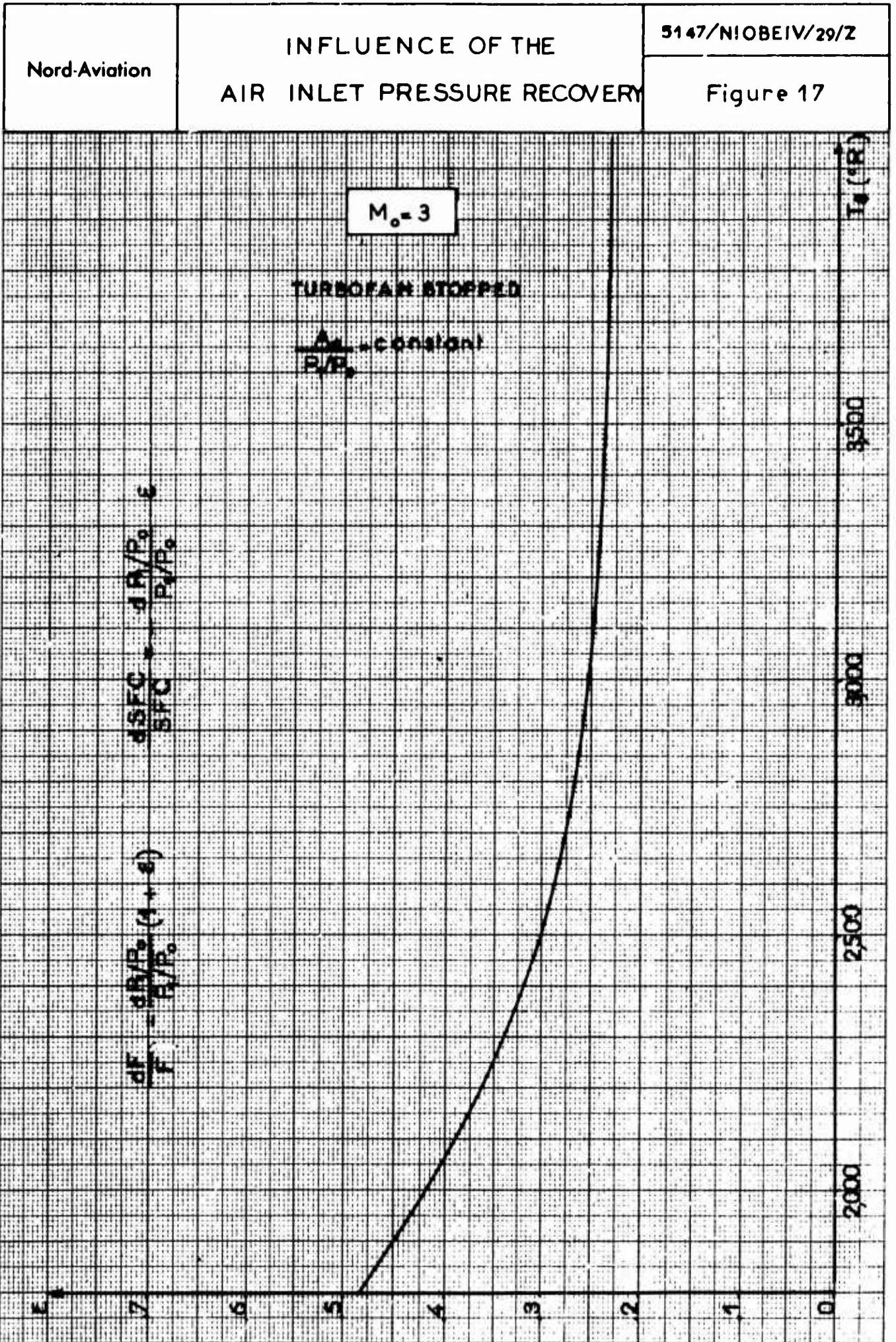

LE DOCUMENT EST LA PROPRIÉTÉ DE NORD AVIATION
 IL NE PEUT ÊTRE UTILISÉ, REPRODUIT OU COMMUNIQUÉ
 SANS SON AUTORISATION

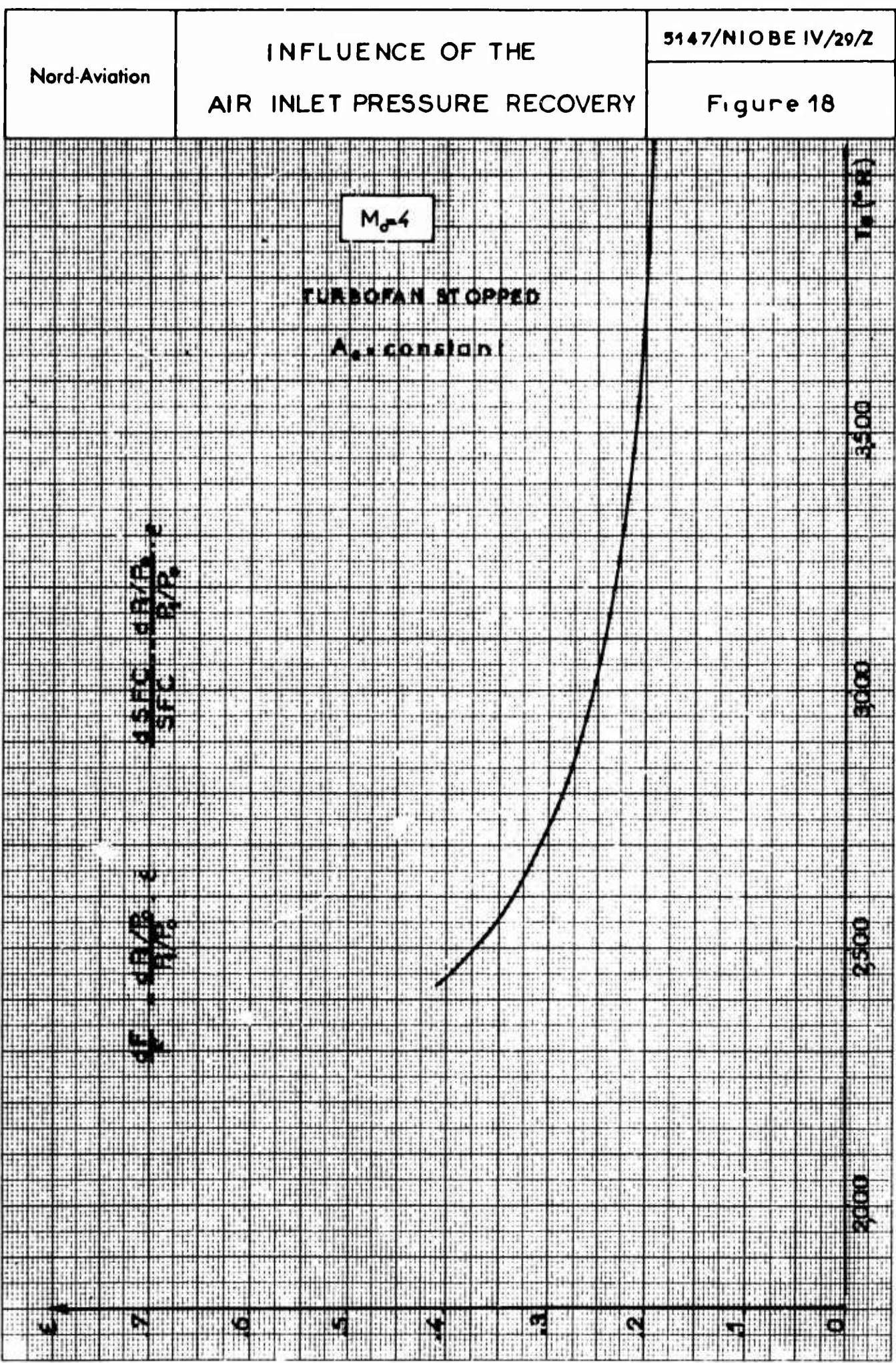

LE DOCUMENT EST LA PROPRIÉTÉ DE NORD AVIATION
 IL NE PEUT ÊTRE UTILISÉ, REPRODUIT OU COMMUNIQUÉ
 SANS SON AUTORISATION

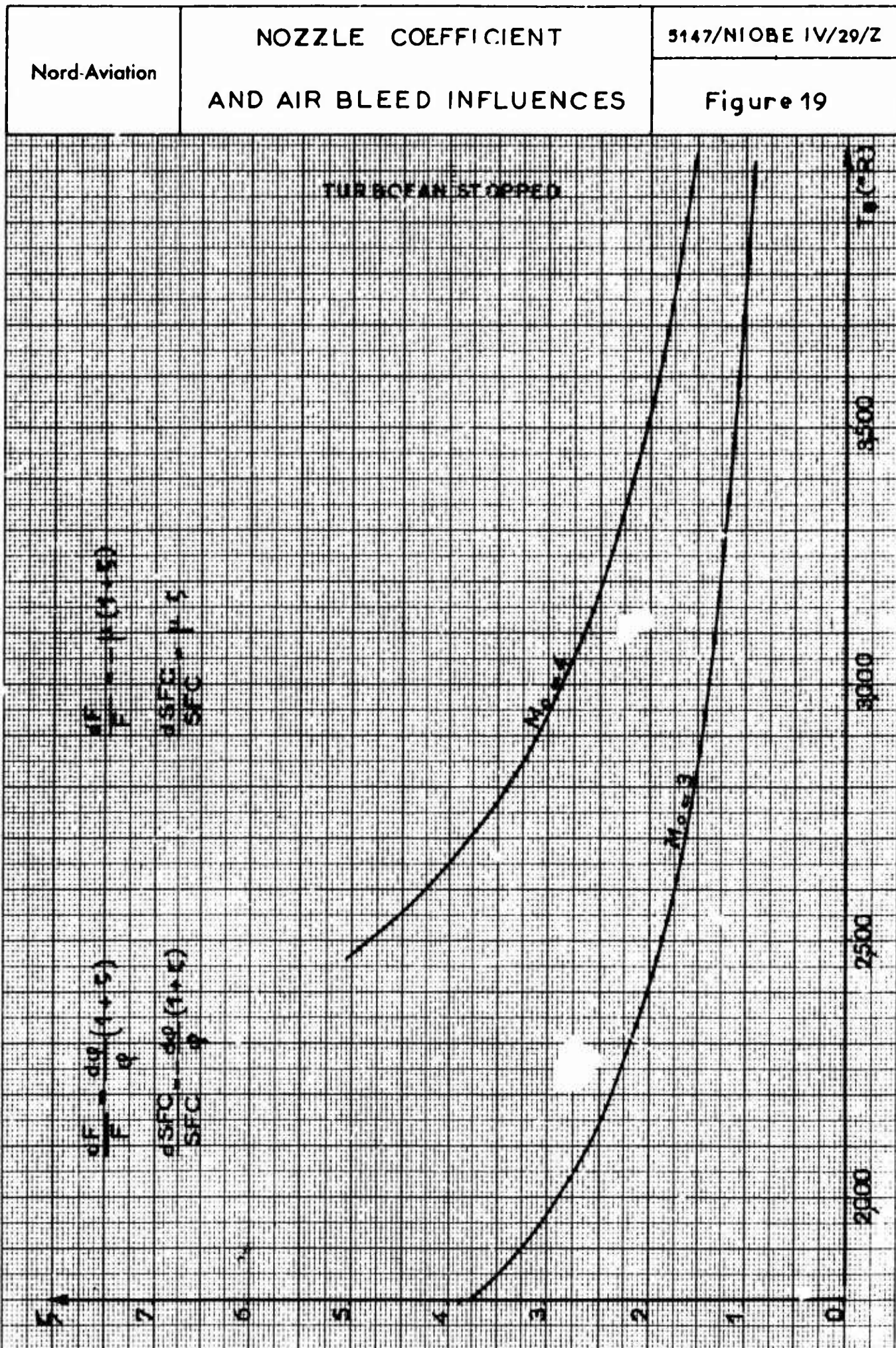

$$\frac{\theta F}{F} = \frac{\theta \rho}{\rho} (1 + \epsilon)$$

$$\frac{\theta SFC}{SFC} = \frac{\theta \rho}{\rho} (1 + \epsilon)$$

$$\frac{\theta F}{F} = \frac{\theta \rho}{\rho} (1 + \epsilon)$$

$$\frac{\theta SFC}{SFC} = \frac{\theta \rho}{\rho} (1 + \epsilon)$$

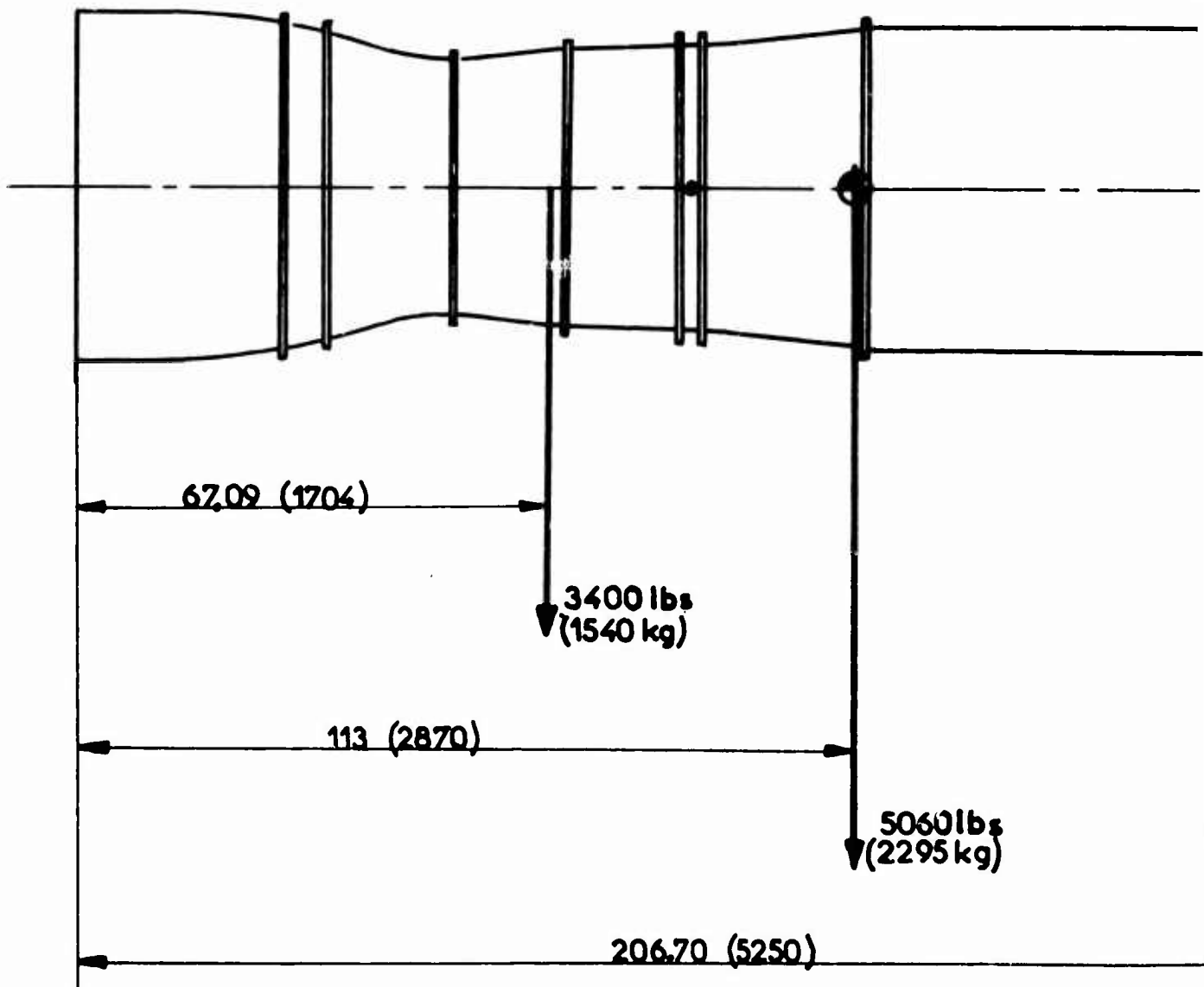

Dimensions are in inches
 () in mm.

XE
NO

1

5147/NIобе IV/29/Z

FIG. 20

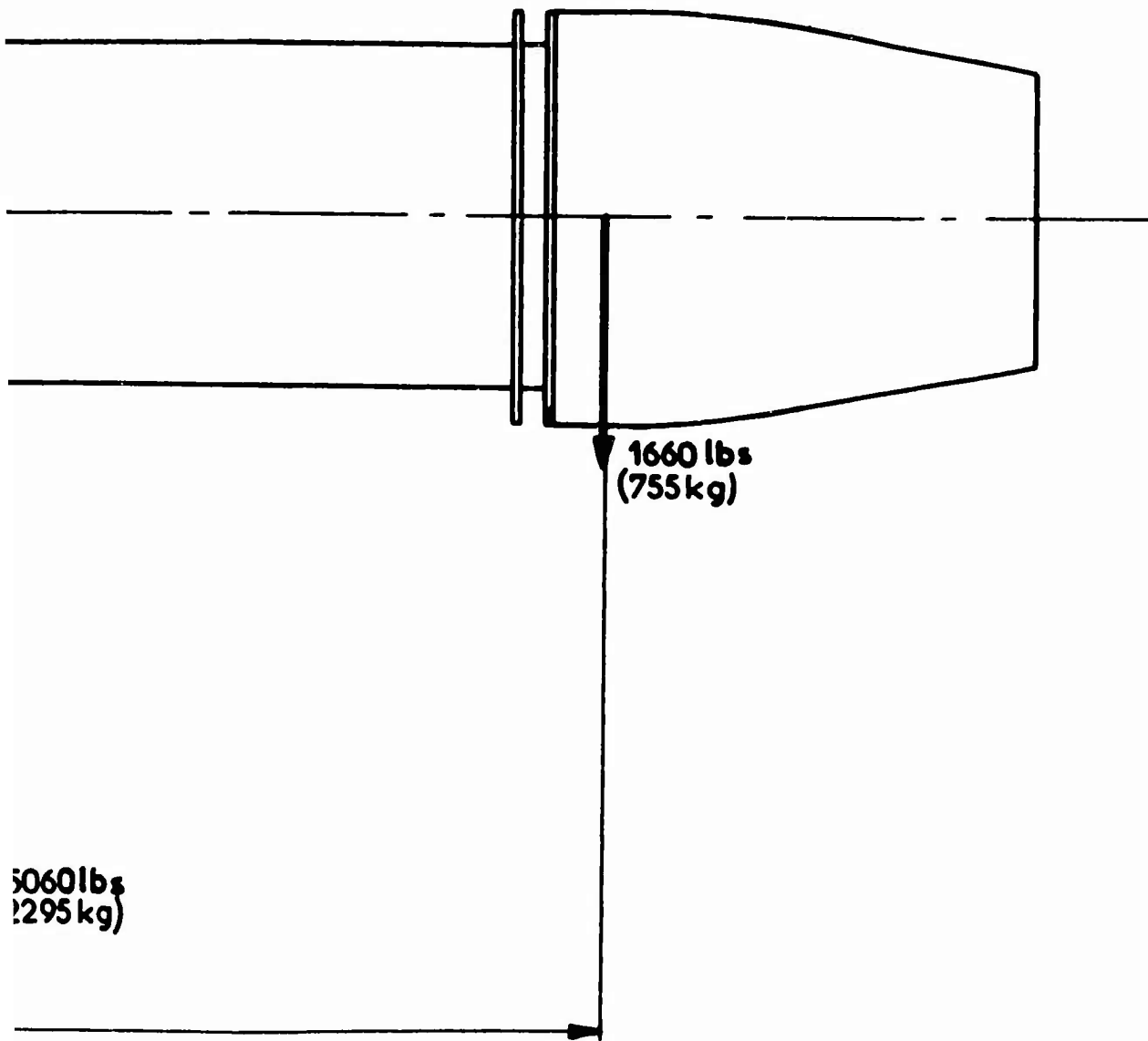

2

X81 TURBOFAN - RAMJET ENGINE

**NORD
AVIATION**

**WEIGHT
CENTER OF GRAVITY**

**SCALE
1/25**

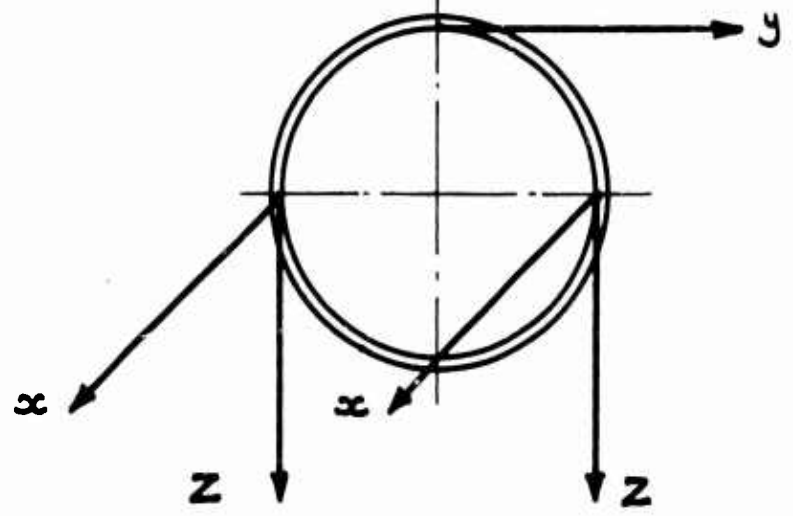
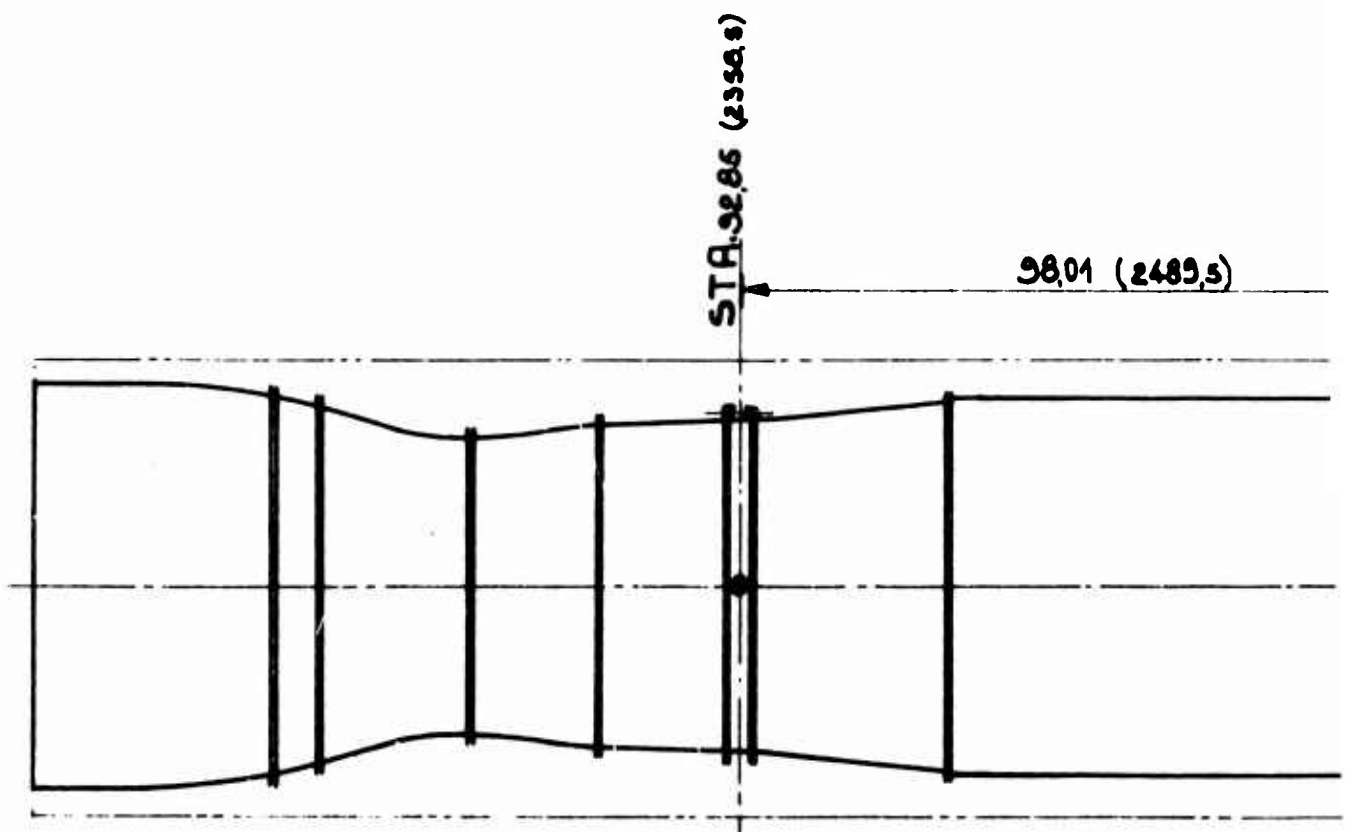

Dimensions are in inches.
 () in mm.

NOF

1

5147/NIOBE IV/29/Z

FIG.21

98.01 (2489,5)

STRA.
130,66 (4648)

STABILIZING MOUNT

(optional mount)

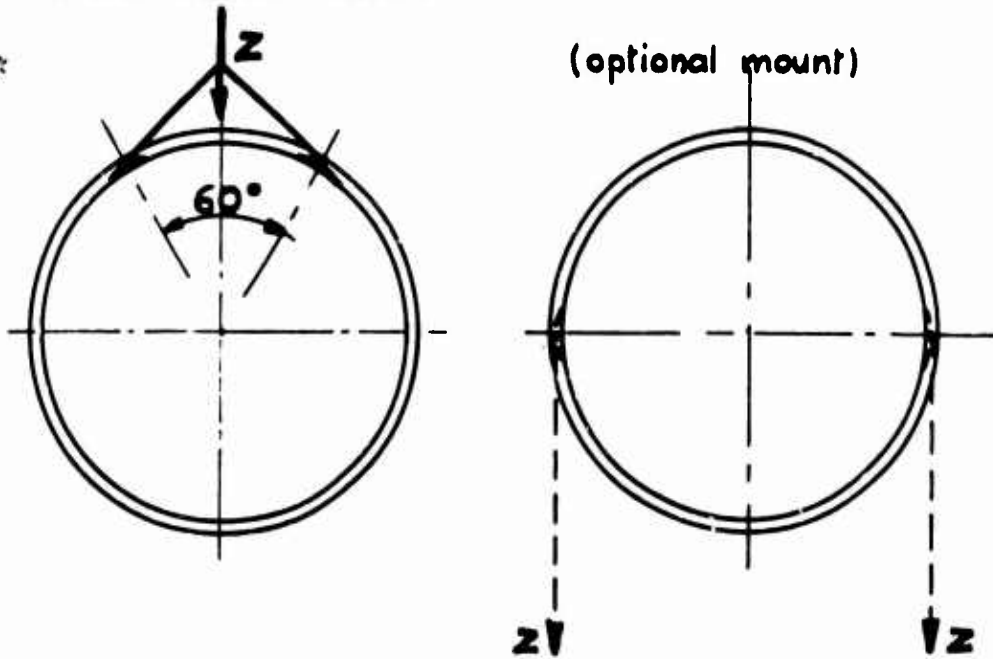

X81 TURBOFAN - RAMJET ENGINE

NORD
AVIATION

MOUNTING SYSTEM

SCALE
1/25

2

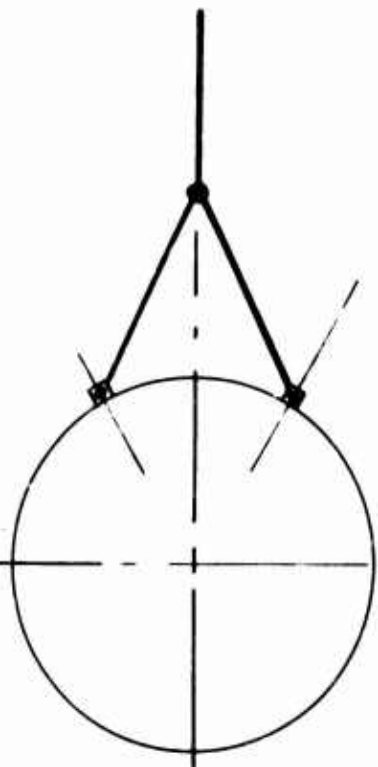

STA. 34.25

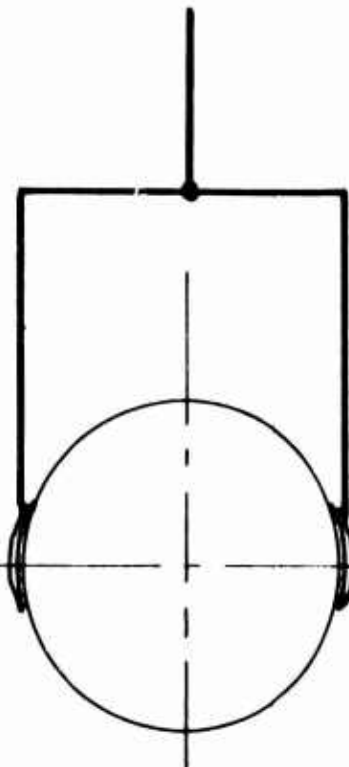

STA. 92.85

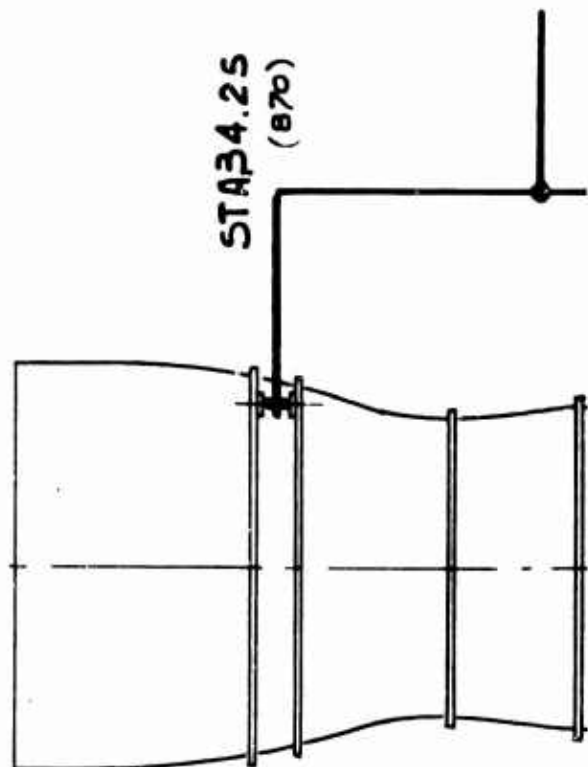

STA. 34.25
(870)

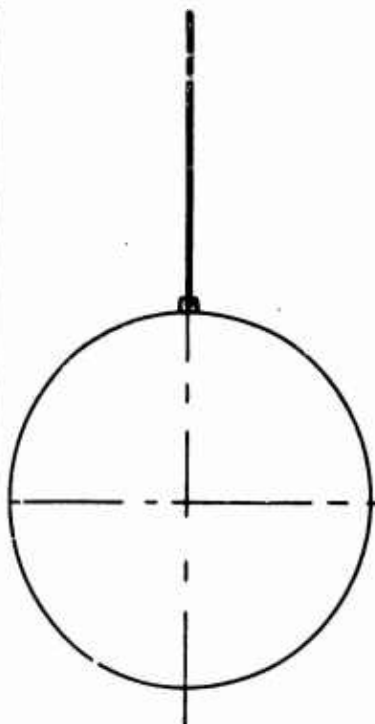

STA. 120.47

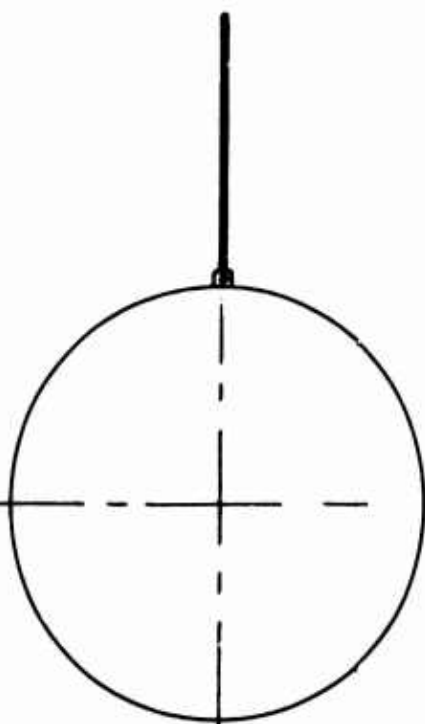

STA. 228.35

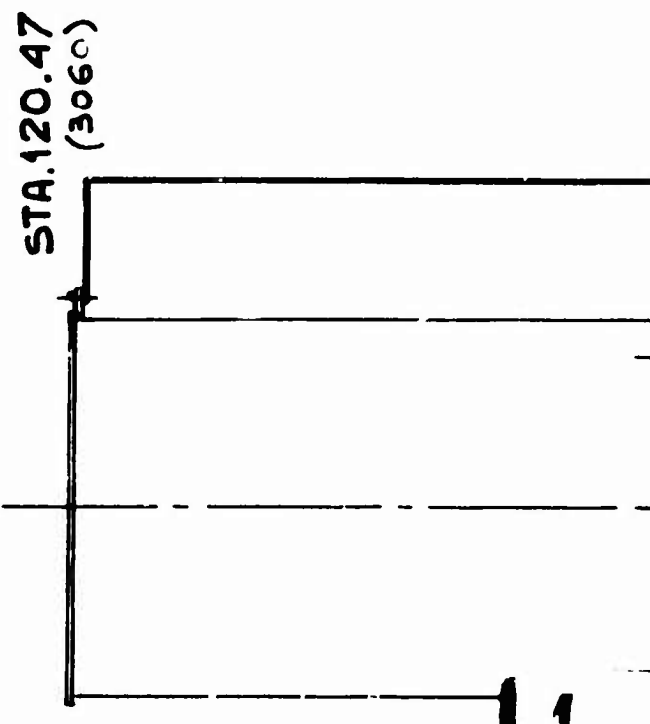

STA. 120.47
(3060)

STA 34.25
(870)

92.85
(2358.5)

STA

219

228.35
(5800)

STA

STA. 34.25
(870)

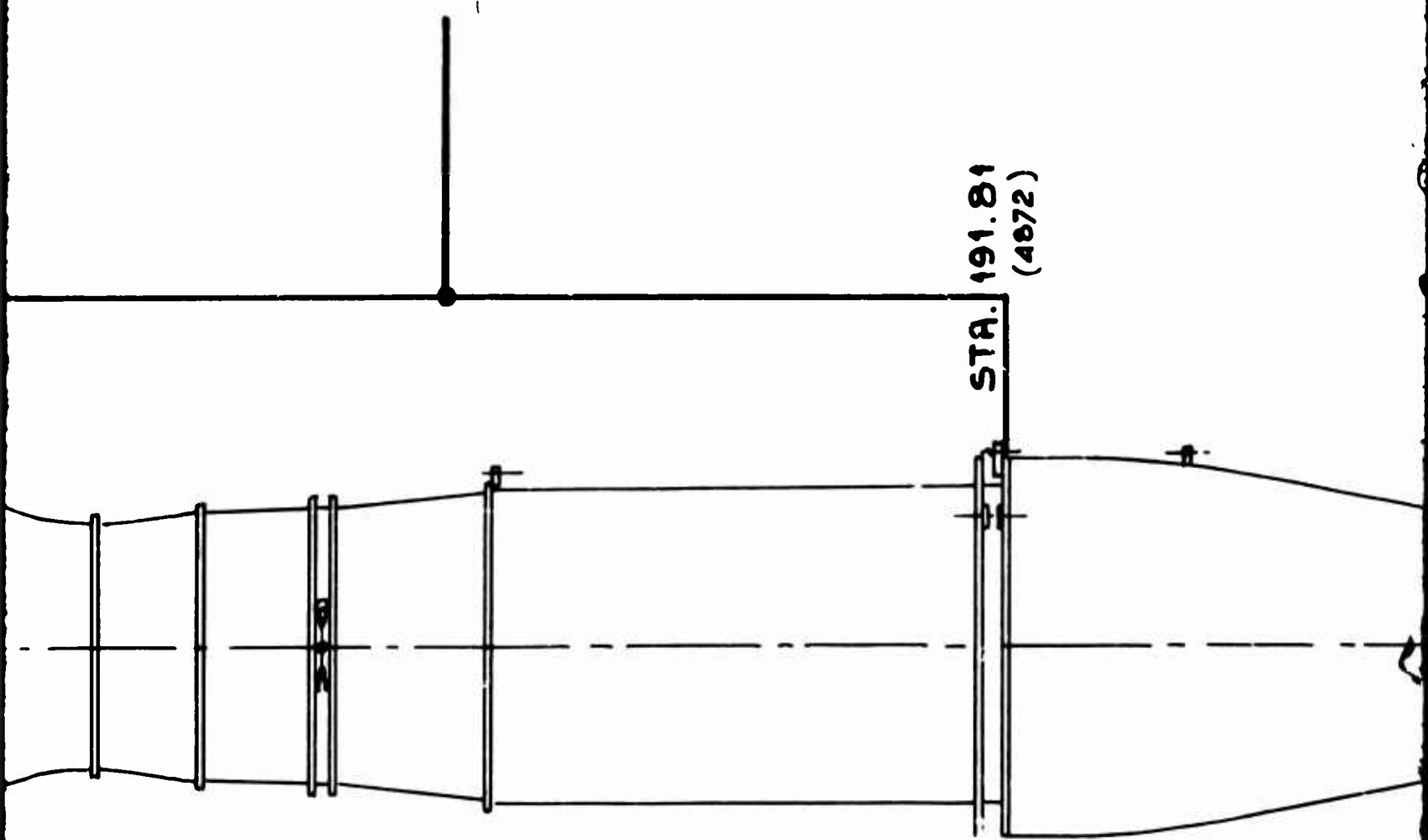

Dimensions are in inches.
() in mm.

X81 TURBOFAN - RAMJET ENGINE		
NORD AVIATION	GROUND HANDLING	3

5147/NIOBE IV/29/Z

FIG. 22

STA. 191.81
(4872)

Dimensions are in inches.
() in mm.

4

X81 TURBOFAN - RAMJET ENGINE

NORD
AVIATION

GROUND HANDLING

SCALE
1/25

Unclassified
Security Classification

DOCUMENT CONTROL DATA - R&D		
<i>(Security classification of title, body of abstract and indexing annotation must be entered when the overall report is classified)</i>		
1. ORIGINATING ACTIVITY (Corporate author) Nord Aviation Rue Beranger Chatillon-sous-Bagneux, France	2a. REPORT SECURITY CLASSIFICATION Unclassified	2b. GROUP N/A
3. REPORT TITLE EXPERIMENTAL AND DESIGN STUDIES FOR TURBO-RAMJET COMBINATION ENGINE Volume I - Specifications and Performance		
4. DESCRIPTIVE NOTES (Type of report and inclusive dates) Final Report		
5. AUTHOR(S) (Last name, first name, initial) Chaulin, P. Ravel, M. and Gozlan, A.		
6. REPORT DATE January 1966	7a. TOTAL NO. OF PAGES 50	7b. NO. OF REFS ---
8a. CONTRACT OR GRANT NO. AF 61(052)-750 b. PROJECT NO. 3012 c. Task No. 301203 d.	9a. ORIGINATOR'S REPORT NUMBER(S) 5147/NIOBE IV/29/Z 9b. OTHER REPORT NO(S) (Any other numbers that may be assigned this report) AFAPL-TR-66-34, Volume I	
10. AVAILABILITY/LIMITATION NOTICES This document is subject to special export controls and each transmittal to foreign governments or foreign nationals may be made only with prior approval of the Turbine Engine Division, Air Force Aero Propulsion Laboratory, Wright-Patterson Air Force Base, Ohio 45433		
11. SUPPLEMENTARY NOTES ---	12. SPONSORING MILITARY ACTIVITY Air Force Aero Propulsion Laboratory Wright-Patterson Air Force Base, Ohio 45433	
13. ABSTRACT The effort to demonstrate the feasibility and the efficiency of the Nord-Aviation combined turbofan-ramjet engine within the range of Mach numbers from 0 to 4.5 is reviewed. A complete performance-characteristics plot for the Nord-Aviation X-81 combined engine built around the selected SNECMA TF 106 turbofan is established. The combustion system is studied over a largely extended equivalence ratio range and covers all the possible requirements to Mach 4 and for an altitude ranging to 100,000 feet. The investigation was conducted on a two-dimensional model representing a portion of an actual annular combustion chamber.		

DD FORM 1473
1 JAN 64

Unclassified
Security Classification