

UNCLASSIFIED

AD NUMBER
AD487447
NEW LIMITATION CHANGE
TO Approved for public release, distribution unlimited
FROM Distribution: Further dissemination only as directed by Air Force Aero Propulsion Laboratory, Attn: AFSC, Wright-Patterson AFB, OH 45433, Aug 1966, or higher DoD authority.
AUTHORITY
AFAPL ltr, 12 Apr 1972

THIS PAGE IS UNCLASSIFIED

487447

AFAPL-TR-66-71

INVESTIGATION OF HAZARDOUS VAPOR DETECTION
FOR ADVANCED FLIGHT VEHICLES

O. Cucchiara, L. Seiden and T. Donaghue
Parametrics, Incorporated
Waltham, Massachusetts

TECHNICAL REPORT AFAPL-TR-66-71
August 1966

Air Force Aero Propulsion Laboratory
Research and Technology Division
Air Force Systems Command
Wright-Patterson Air Force Base, Ohio

NOTICES

When Government drawings, specifications, or other data are used for any purpose other than in connection with a definitely related Government procurement operation, the United States Government thereby incurs no responsibility nor any obligation whatsoever; and the fact that the Government may have formulated, furnished, or in any way supplied the said drawings, specifications, or other data, is not to be regarded by implication or otherwise as in any manner licensing the holder or any other person or corporation, or conveying any rights or permission to manufacture, use, or sell any patented invention that may in any way be related thereto.

Copies of this report should not be returned to the Research and Technology Division unless return is required by security considerations, contractual obligations, or notice on a specific document.

**INVESTIGATION OF HAZARDOUS VAPOR DETECTION
FOR ADVANCED FLIGHT VEHICLES**

O. Cucchiara, L. Seiden, and T. Donaghue

FOREWORD

This report was prepared by Parametrics, Incorporated, Waltham, Massachusetts, on Air Force Contract AF 33(615)-2477, "Investigation of Hazardous Vapor Detection for Advanced Flight Vehicles." The contract was initiated under Project No. 6075, Task No. 607508. The work was administered under the direction of Fuels Lubrication and Hazards Branch, Support Technology Division, AF Aero Propulsion Laboratory, Research and Technology Division. Mr. Robert E. Cretcher served as project engineer for the Laboratory.

The studies presented here were conducted in the period 15 March 1965 through 15 March 1966 by the Chemistry Department of Parametrics, Incorporated, Dr. Philip Goodman, Director. Mr. Orlando Cucchiara was the principal investigator.

This report was submitted by the authors July 1966.

This technical report has been reviewed and is approved.

Arthur V. Churchill

ARTHUR V. CHURCHILL, Chief
Fuels Lubrication and Hazards Branch
Support Technology Division

ABSTRACT

A program was conducted to evaluate techniques for the detection of hydrocarbon vapors and hydrogen aboard advanced aircraft.

A radiochemical exchange technique utilizing kryptonates can be employed satisfactorily for detecting hydrocarbon vapors aboard aircraft with a Mach 3 to Mach 6 capability and hydrogen for Mach 7 and higher capability aircraft. However, it was shown that it is highly unlikely that hydrogen will exist in the presence of oxygen at temperatures in excess of 1300° F. Therefore, an aluminum oxide humidity element was investigated as to its ability to detect the water formed by combustion. This element appears suitable assuming that further development of the element can overcome its present maximum temperature limitations.

A nondispersive, open-path, infrared technique can, in principle, be upgraded to detect hydrocarbon fuels, (not hydrogen or water), under the stipulated environmental conditions; however, a considerable developmental effort would be required.

Catalytic combustion is limited in its applicability due to its relatively poor sensitivity, stability and operating life. A photoionization technique appears most promising but will require a considerable developmental effort.

TABLE OF CONTENTS

I. INTRODUCTION	1
II. TECHNICAL DISCUSSION	3
A. General Requirements	3
B. Evaluation of the Kryptonate Technique for Combustible Fuel Detection	4
1. Background	4
2. JP-6 Fuel	7
a. Test Systems	7
b. Calibration of JP-6 - Air Mixture	9
c. Investigation of Kryptonated Sensors for JP-6 Detection	10
d. Investigation of Kryptonated Sources for JP-6 Detection in Mach 4 to Mach 6 Type Aircraft	19
3. Hydrogen	21
4. Discussion of Results and General Evaluation of the Kryptonate Technique	26
a. Pressure	26
b. Response Time	27
c. Selectivity	27
C. Evaluation of the Infrared Technique for Combustible Fuel Detection	28
1. Introduction	28
2. Evaluation	32
a. Species	33
b. Concentration Levels	34
c. Ambient Temperature	34
3. Conclusions	42
D. Aluminum Oxide Hygrometer	42
1. Detection of JP-6 Fuel with the Al ₂ O ₃ Humidity Sensor	44
a. Effect of Ambient Water	46
b. Detection of JP-6 with the Humidity Sensor at Temperatures < 700° F	48
c. Ability of Humidity Sensor to Operate at Elevated Temperatures	50
2. Detection of Hydrogen with the Al ₂ O ₃ Sensor	50
a. Experimental Evaluation of Al ₂ O ₃ Sensor for Hydrogen	51
b. Discussion of Results	53

E. Other Techniques	53
1. Catalytic Combustion	53
2. Photoionization	56
III. CONCLUSIONS	61
REFERENCES	63

ILLUSTRATIONS

FIGURE		PAGE
1.	Kryptonate Detection System	6
2.	Apparatus for Evaluating Kryptonate Sensors	8
3.	Response of $\text{PtO}_2\text{Kr}^{85}\text{-Al}_2\text{O}_3$ to JP-6 Vapor	13
4.	Response of $\text{PtO}_2\text{Kr}^{85}\text{-Al}_2\text{O}_3$ at 700°F and 800°F to JP-6 Vapors	14
5.	Response of $\text{PtO}_2\text{Kr}^{85}\text{-Al}_2\text{O}_3$ Sensor (70°F) to JP-6 Vapors at 70°F to 1250°F	16
6.	Gas Chromatograph of JP-6 Vapors Collected at 70°F	17
7.	Test System for Determining the Effect of Hot Surfaces on the $\text{H}_2\text{-O}_2$ Reaction	22
8.	Response of $\text{PtO}_2\text{Kr}^{85}$ to H_2 at Various H_2 Vapor Temperatures	23
9.	MSA Explosive Vapor Detector (Schematic)	29
10.	High-Temperature Test Cell	31
11.	Variation in Concentration with Temperature (Vented Chambers)	36
12.	Apparent "Absorption" Due to Thermal Background (Per cm^2 Effective Radiation Area)	43
13.	Response of Al_2O_3 Hygrometer to H_2O Vapor Formed on Partial Combustion of JP-6 Fuel	45
14.	Water Vapor Concentration VS. Altitude	47
15.	Al_2O_3 Humidity Element System for Detection of JP-6	49

ILLUSTRATIONS (cont'd)

FIGURE		PAGE
16.	Response of Al_2O_3 to H_2O Vapor Formed on Combustion of Hydrogen	52
17.	Comparison of Response of Humidity Sensor and Kryptonate Sensor to 0.5% H_2	54
18.	Photoionization Detector	58

SECTION I

INTRODUCTION

The continuing progress made in the development of advanced aircraft has brought with it ever increasing difficulties of coping with fires and explosions. Leakage of combustible fuel vapors into various compartments of an advanced aircraft can rapidly lead to explosive fuel-air mixtures. Under such conditions, any ignition source with suitable energy, will produce catastrophic results. Although many standard prevention techniques such as isolation, venting, purging, etc. are employed to minimize the possibility of such a condition, it is anticipated that at some point in the mission profile, such a condition will exist. The need for reliable instrumentation capable of in-flight detection of these hazardous vapor fuels is then of extreme importance. The ambient conditions existing in certain compartments of high-speed aircraft are extremely severe, making detection of these vapors a difficult problem. As progress continues in the development of advanced aircraft to the supersonic and hypersonic regimes, the in-flight detection of hazardous vapors becomes increasingly difficult and complex.

It is the purpose of this report to evaluate detection techniques for hazardous vapors of hydrocarbons and hydrogen aboard advanced aircraft operating from Mach 3 to Mach 8. An investigative and experimental program was conducted to define the limitations and capabilities of present state-of-the-art techniques in satisfying certain physical, operational and design requirements. These state-of-the-art techniques included a radio-chemical exchange technique using kryptonates and an open path, nondispersive, infrared technique.

It is believed that the kryptonates and infrared techniques can be upgraded without difficulty to meet the requirements necessary for the detection of hydrocarbon fuels aboard advanced aircraft with a Mach 3 to Mach 6 capability. Although both these techniques can be used for hydrocarbon detection, the infrared technique cannot be used for the detection of hydrogen under any conditions. The kryptonate technique can be used to detect hydrogen under all the specified conditions; however, the existence of this gas is highly unlikely at the environmental temperatures expected in Mach 7 or higher capability aircraft. Therefore, an advanced concept employing an aluminum oxide hygrometer was investigated. Although the development of this concept was beyond the scope of the effort, the feasibility of the technique to detect hydrogen (and hydrocarbon) by measuring the water formed on combustion was demonstrated experimentally.

A detection technique utilizing catalytic combustion was investigated. Insufficient time was available for a thorough evaluation of this concept. The technique appears promising for hydrocarbon or hydrogen detection. However,

limitations in sensitivity, stability and operating life would appear to limit its applicability.

A brief evaluation of an advanced concept employing photoionization was conducted. Although this technique is not suitable for the detection of hydrogen, it is believed that it can be satisfactorily employed as a hydrocarbon detector. Definite conclusions as to its ability to measure hydrocarbons under the specified environmental conditions would require a thorough experimental evaluation.

SECTION II

TECHNICAL DISCUSSION

An investigative and experimental program to define the limitations and capabilities of present state-of-the-art techniques and other advanced concepts to provide a combustible vapor warning capability for future aircraft was conducted. The results of this study are presented below.

A. GENERAL REQUIREMENTS

The assumed physical and operational parameters and design requirements under which the detection system must be capable of detecting fuel vapors are listed below.

- (1) Aircraft to be considered are manned and are propelled by air breathing systems.
- (2) Six aircraft are to be considered with capability for operating at Mach 3, 4, 5, 6, 7 and 8.
- (3) Assumed maximum environmental ambient temperatures for detector system components are:
 - (a) Mach 3 - 550^oF
 - (b) Mach 4 - 850^oF
 - (c) Mach 5 - 1100^oF
 - (d) Mach 6 - 1200^oF
 - (e) Mach 7 - 1300^oF
 - (f) Mach 8 - 1400^oF
- (4) Minimum ambient temperature is -65^oF.
- (5) Assumed operational altitude is sea level to 100,000 ft.
- (6) Fuels to be considered are hydrocarbon type and hydrogen. Hydrocarbon fuels are to be considered for Mach 3 to Mach 6 capability and hydrogen fuel for higher speed engines.
- (7) Technique must detect presence of hydrocarbon fuel concentrations of 1/4 by volume of the lower explosive limit and hydrogen vapor concentrations of 1% by volume.
- (8) Response time must be in the order of seconds.
- (9) The technique must be selective to the vapor to be detected in the presence of other gases likely to be present in the atmosphere.

(10) The technique must be capable of repetitive operation without re-servicing, i. e., indicate both presence and elimination of hazardous concentrations.

(11) As a special consideration, the detection of hydrogen vapors is required under the following conditions of dynamic air flow:

- (a) Pressure - 250 psia
- (b) Temperature - 1800° F
- (c) Air Flow - 1400 pounds per second.

These requirements seriously limit the number of available detection techniques which could be employed to detect hydrocarbons and hydrogen. The technique must have rapid response, selectivity and wide temperature range operation. In addition, the technique must be capable of detecting these gases at pressures ranging from those encountered at sea level to 100,000 feet. Since the detection instrument will be employed aboard advanced flight vehicles, further requirements on weight, size and power must be considered.

The most critical requirement and that which most severely limits the selection of a detection technique is that of high temperature operation. Ideally, for rapid response times the sensor unit should be placed directly in the hot compartment of interest. This sensor unit should be capable of withstanding the environmental temperatures and should not require auxiliary electronic equipment in its proximity (electronic components such as resistors, capacitors, etc. cannot operate at temperatures in excess of 300° F). With such a system, only electrical leads from the hot test compartment leading to remote auxiliary power and readout equipment would be necessary. Such techniques as gas chromatography, automated wet chemical analysis, mass spectrometry, paramagnetism, and electrochemical methods cannot be designed to meet the above requirements of high temperature operation which are necessary to achieve fast response times.

The techniques which appeared to most nearly fulfill the above requirements are discussed below. These techniques were selected on the ability of the sensor unit alone to withstand the environmental conditions. It is assumed throughout the discussion of this report that all associated electronic support equipment can be located in cooled areas or can be cooled directly in the hot compartment.

B. EVALUATION OF THE KRYPTONATE TECHNIQUE FOR COMBUSTIBLE FUEL DETECTION

1. Background

Kryptonates are solid materials containing the inert radioisotope

krypton-85. The preparation and properties of these unique solid materials have been described amply in the literature ¹⁻⁶. These sources are stable with time and room temperature, and can be stabilized for use at elevated temperatures. For the present application, the most important property of kryptonates is that the solid radioactive source will release gaseous krypton-85 if the surface structure of the solid is chemically altered. Such an alteration occurs when the kryptonated solid is attacked by a reacting gaseous specie. The gaseous activity released on reaction is directly proportional to the rate of the reaction of the solid with the gas and hence is a function of the gas concentration. Thus by monitoring the release in activity on reaction with a particular gas, the concentration of the gas can be ascertained.

This is precisely the technique which has been employed successfully for the detection of numerous gaseous species. ⁴⁻⁹ By selecting a solid which reacts rapidly with a desired gaseous constituent and applying the radiokrypton homolog of that solid, such varied gases as fluorine, hydrogen sulfide, hydrochloric acid, hydrazine, nitrogen dioxide, hydrogen, and others can be accurately and reliably detected.

The general mode of operation of this technique is shown schematically in Figure 1. The system consists basically of a cell containing the kryptonate sensing material and a counting chamber for counting the effluent gas released. The ambient gas is drawn through the sensor cell by means of an air pump. Reaction of the kryptonated solid and the reactant gas occurs, krypton-85 being released in the process. The released krypton-85 is drawn into the counting chamber and detected with the radiation detector. The count rate obtained is proportional to the vapor concentration.

An instrument for the detection of hydrogen, fluorine and fluorine containing oxidizers was developed. ⁹ This instrument was designed as an alarm type prototype model which would be capable of detecting the above gas constituents around ground base installations. Of most pertinence to this report, this instrument was designed to detect hydrogen vapor concentrations of 1% or less with a response time of the order of a few seconds.

The specific sensor used for hydrogen detection was a mixture of aluminum oxide and kryptonated platinum dioxide. Hydrogen reduces the platinum dioxide forming water and releases krypton-85. The aluminum oxide acts as a molecular barrier to oxygen to prevent the catalytic reaction of hydrogen and oxygen to occur.

Under normal kryptonating conditions, platinum dioxide particles are kryptonated for a depth of only about 1000 \AA from the surface. Hydrogen initially reacts with the surface, releasing Kr^{85} . Hydrogen reaction continues with the particle until it is completely reduced to the metal, however, there is no krypton available at depths below 1000 \AA to be released. As a result, at the constant hydrogen concentration the release in activity is initially large and

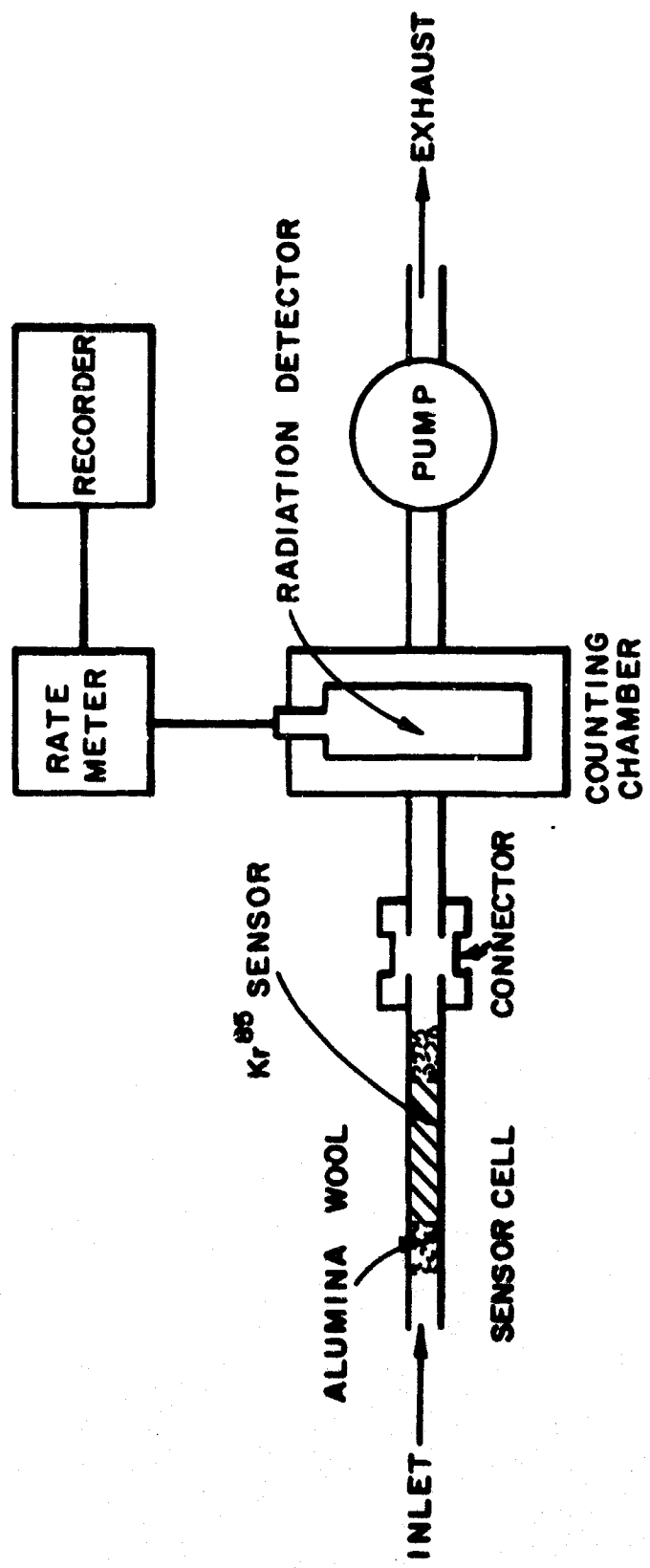

Figure 1. Kryptonate Detection System

then decreases. It is apparent then, that an effluent system with an inhomogeneously kryptonated platinum cannot be used for continuous monitoring, nor, because of the normal hydrogen background, can it be used for an alarm system. The instrument described above utilized inhomogeneously kryptonated platinum dioxide. It was therefore necessary to monitor both the direct source strength and the effluent release. The ratio of these is constant for a constant hydrogen concentration and independent of the source activity.

The difficulties described above were overcome with the development of homogeneously kryptonated platinum dioxide. By varying the kryptonating parameters, it was found that platinum dioxide can be routinely produced with krypton-85 distributed throughout the entire particles. It was shown that krypton-85 will be released continuously at all hydrogen concentrations investigated, until the entire source was completely reduced to metallic platinum. The amount of krypton-85 released is directly proportional to the hydrogen concentration, and remains constant at any constant hydrogen concentration.

Since this technique has been well established and indeed can be considered as a current state-of-the-art technique, an evaluation of this technique was conducted to determine if the technique could be upgraded to detect hydrocarbon vapors and hydrogen aboard aerospace flight vehicles under the stipulated environmental conditions.

2. JP-6 Fuel

JP-6 is a kerosene based fuel consisting of numerous hydrocarbon components. Preliminary experiments had shown that JP-6 fuel will react with homogeneously kryptonated platinum dioxide continuously and reproducibly. However, since kryptonated platinum dioxide decomposes at 842°F, it was necessary to determine if a kryptonated sensor could be produced that would successfully detect JP-6 to a maximum temperature of 1200°F. A factor of equal importance to be determined was the effect of these high temperatures on the fuel itself, since it was believed possible that cracking, oxidation or catalytic combustion of the fuel might occur at these temperatures making detection of the fuel itself difficult.

a. Test Systems

The apparatus used to evaluate the kryptonate technique for use in the detection of JP-6 fuel is shown in Figure 2. The essential element of this system is the environmental test chamber. This chamber consists basically of a 4-1/2 inch inside diameter, 14 inch long refractory alumina tube wire wound with 18 gauge nichrome wire. Alumina wool is used to insulate the tubing. The entire assembly is housed in transit. A door is provided for access to the chamber. This oven is used to simulate the engine compartment or other environmental area of a manned aircraft.

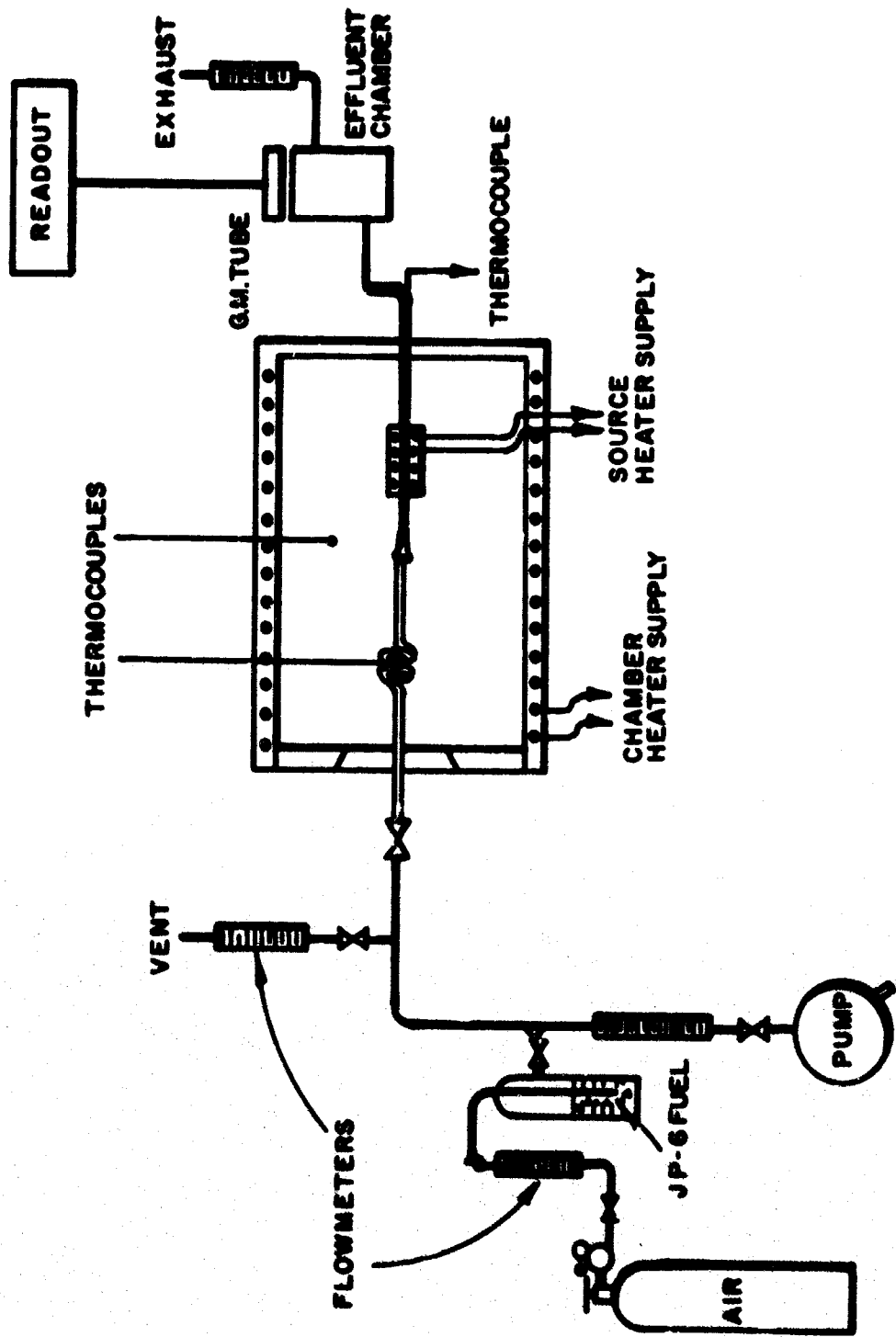

Figure 2. Apparatus for Evaluating Kryptonate Sensors

The sensor cell containing the kryptonate detector is mounted within the test chamber. A secondary heater is utilized for the sensor cell to maintain the sensor at a higher constant temperature than the environmental chamber. This insures a constant reaction rate and hence a constant effluent signal even though the chamber itself may fluctuate by several hundred degrees.

Air is passed through the bubbler containing JP-6 fuel. The air fuel mixture is then diluted to the desired concentration and passed through a coiled quartz tube contained in the chamber. The coiled quartz insures that the air-fuel mixture reaches the equilibrium temperature of the oven. The gas mixture is then passed over the kryptonated sensor where reaction occurs. The released activity due to the reaction is then passed to an effluent counter and the amount of activity released recorded. Temperatures of the environmental chamber, the inlet gas temperature and the kryptonate sensor were monitored by means of chromel-alumel thermocouples.

By simply disconnecting the coiled quartz tube from the kryptonate source, the air-fuel mixture can be introduced directly into the environmental chamber. The test gas can then be passed over the source by connecting a small air pump at the exhaust of the effluent counting chamber. This modification was utilized to investigate the effect of the environmental walls on decomposition of the fuels at elevated temperatures.

This environmental chamber was used to simulate advanced aircraft compartments at temperatures from 70°F to 1500°F. The kryptonated source itself could be heated to temperatures up to 2000°F.

b. Calibration of JP-6 - Air Mixture

Since JP-6 fuel is a liquid at room temperature, it is not possible to obtain standard gaseous air-fuel mixtures as is the case with hydrogen and other very low boiling point gases. There are several techniques that could be used to obtain known gaseous concentrations. One technique involves the use of a diffuser in which the gas is introduced into an air stream by passage of the fuel vapors through a capillary diffusion tube.¹⁰ The concentrations obtained depend mainly on the vapor pressure of the fuel. A simpler technique is to simply pass an air stream through the liquid fuel. This stream then becomes saturated with the fuel vapors. A second air stream can then be used to dilute this saturated air stream to the desired concentrations. This is the technique that was ultimately used.

Saturation levels of JP-6 fuel in air were experimentally determined. Dry air was bubbled through the liquid JP-6 at known flow rates for known periods of time. The JP-6 vapors were collected in a water bath at 32°F using a cold trap of known weight. The cold trap was reweighed to determine the weight of JP-6 trapped. Knowing the weight of JP-6, and the volume of air passed through the bubbler, the concentration of JP-6 in the saturated air

stream can be readily calculated in terms of milligrams per liter or in weight percent. The average molecular weight of JP-6 is not well defined and can vary considerably, depending on the ratio of hydrocarbon mixtures utilized (specific gravity range from 0.78 to 0.84¹¹). As a result, all percent compositions discussed in this report for JP-6 vapors will be in terms of weight percent rather than volume percent.

The formula used to calculate the actual weight percent of JP-6 vapors in air after dilution of the JP-6 saturated air stream with additional air is:

$$\% \text{ JP-6 by wgt} = \frac{100 w}{F_s t \rho} \left(\frac{F_s}{F_a + F_s} \right) \quad (1)$$

where

w = Wgt of JP-6 collected in cold trap (mg)

F_s = Flow rate of saturated air stream (l/min)

t = Time JP-6 collected (min)

ρ = Density of air at room temperature (mg/l)

F_a = Flow rate of diluting air stream (l/min).

If the saturated air stream velocity is maintained constant, then the equation can be reduced to

$$\% \text{ JP-6} = K \left(\frac{F_s}{F_a + F_s} \right) \quad (2)$$

where K is a constant as long as room temperature does not vary by more than $\pm 5^\circ \text{F}$.

With a saturated air stream velocity of 0.3 l/min the concentration of JP-6 was found to be 0.58% by weight. By dilution of this JP-6 saturated air stream with the secondary air supply, concentrations down to 0.015% by weight were obtained, i. e., $F_s / (F_a + F_s) = 0.026$.

c. Investigation of Kryptonated Sensors for JP-6 Detection

The obvious choice of kryptonated sensors for JP-6 fuel are kryptonated heavy metal oxides. JP-6 fuel is a reducing agent, and as such it should reduce heavy metal oxides to their elements. The first kryptonated

homolog investigated was kryptonated platinum dioxide. This sensor was highly successful for the detection of hydrogen (see Background) and similar results were expected with JP-6 fuel. Homogeneously kryptonated platinum dioxide with a coating of inert aluminum oxide was loaded in the sensor cell of the environmental chamber. JP-6 fuel at various concentrations was passed through the quartz tube and over the platinum dioxide sensor. The temperature of the environmental chamber was varied from 100°F to 650°F, while the kryptonate source temperature was kept at a constant 700°F. The results of these experiments are shown in Table 1.

Reproducibility in this temperature range with kryptonated platinum dioxide was excellent. The results of a typical experiment showing the reproducibility of $\text{PtO}_2 \cdot \text{Kr}^{85}$ and the constancy of the signal with time is shown in Figure 3. The variation of signal with JP-6 concentration and kryptonate cell temperature is shown in Figure 4. From Table 1 and Figure 4, it is apparent that within statistical deviations, the signal is independent of the environmental temperature and is linear with concentration.

These results indicate that $\text{PtO}_2 \cdot \text{Kr}^{85}$ is an excellent sensor for JP-6 fuel at all temperatures up to 800°F. As long as the sensor itself is operated at a temperature approximately 50°F higher than the expected maximum environmental temperature, environmental temperature fluctuations will not interfere with the constancy of the signal at constant JP-6 concentrations. Thus this sensor material should be suitable for incorporation into a detection system for JP-6 fuel used in advanced flight vehicles with a Mach 3 capability.

Kryptonated platinum dioxide cannot be used above 842°F (decomposition point of PtO_2). Hence for Mach 4 and higher speed aircraft, a kryptonated oxide of higher melting or decomposition point must be used. However, before discussing kryptonated sensors capable of detecting JP-6 above 842°F, the effect of the environmental temperature on the fuel itself will be discussed.

An investigation was conducted to determine whether decomposition, catalytic combustion or partial oxidation of JP-6 occurred at elevated temperatures in the presence of air. The walls of the environmental test chamber (see Figure 2) were lined with 10 mil 302 stainless steel sheet. JP-6 vapors at a concentration of 0.15% by weight in air were fed directly into the steel-lined test chamber. A kryptonated platinum dioxide sensor was mounted external to this test chamber and maintained at room temperature. The chamber vapors were drawn through the sensor cell by means of an air vacuum pump. The JP-6 vapor temperature was monitored within the chamber as well as at the entrance to the kryptonate test cell.

In order to determine the effect of the size of the chamber and hence the residence time of the gas on the degree of dissociation of the JP-6 fuel,

Table I**Response of PtO₂-Kr⁸⁵ at Various JP-6 Vapor Temperatures**

Environmental Temperature °F	PtO ₂ -Kr ⁸⁵ Temperature °F	JP-6 Concentration (% by Wgt)	Signal (cpm)
75	700	.013	1500
110	700	.013	1360
125	700	.013	1450
150	700	.013	1300
175	700	.013	1400
200	700	.013	1440
250	700	.013	1350
350	700	.013	1380
400	700	.013	1530
425	700	.013	1460
500	700	.013	1440
550	700	.013	1400
600	700	.013	1440
625	700	.013	1480
625	700	.018	2100
625	700	.031	4000
625	700	.054	6500

ENVIRONMENTAL TEMP. - 570°F
SENSOR TEMPERATURE - 750°F
JP-6 CONCENTRATION - 058 % by wgt

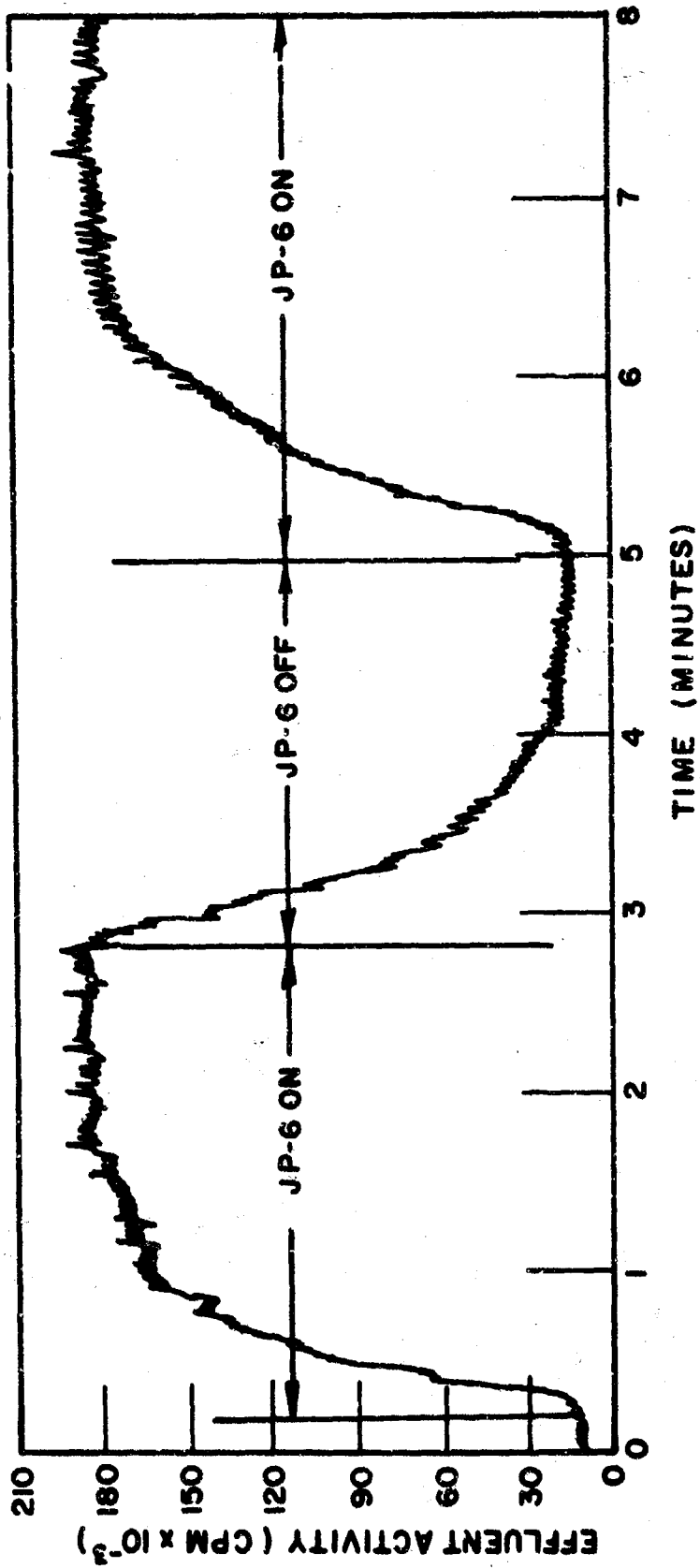

Figure 3. Response of $\text{PtO}_2 \cdot \text{Kr}^{85} - \text{Al}_2\text{O}_3$ to JP-6 Vapor

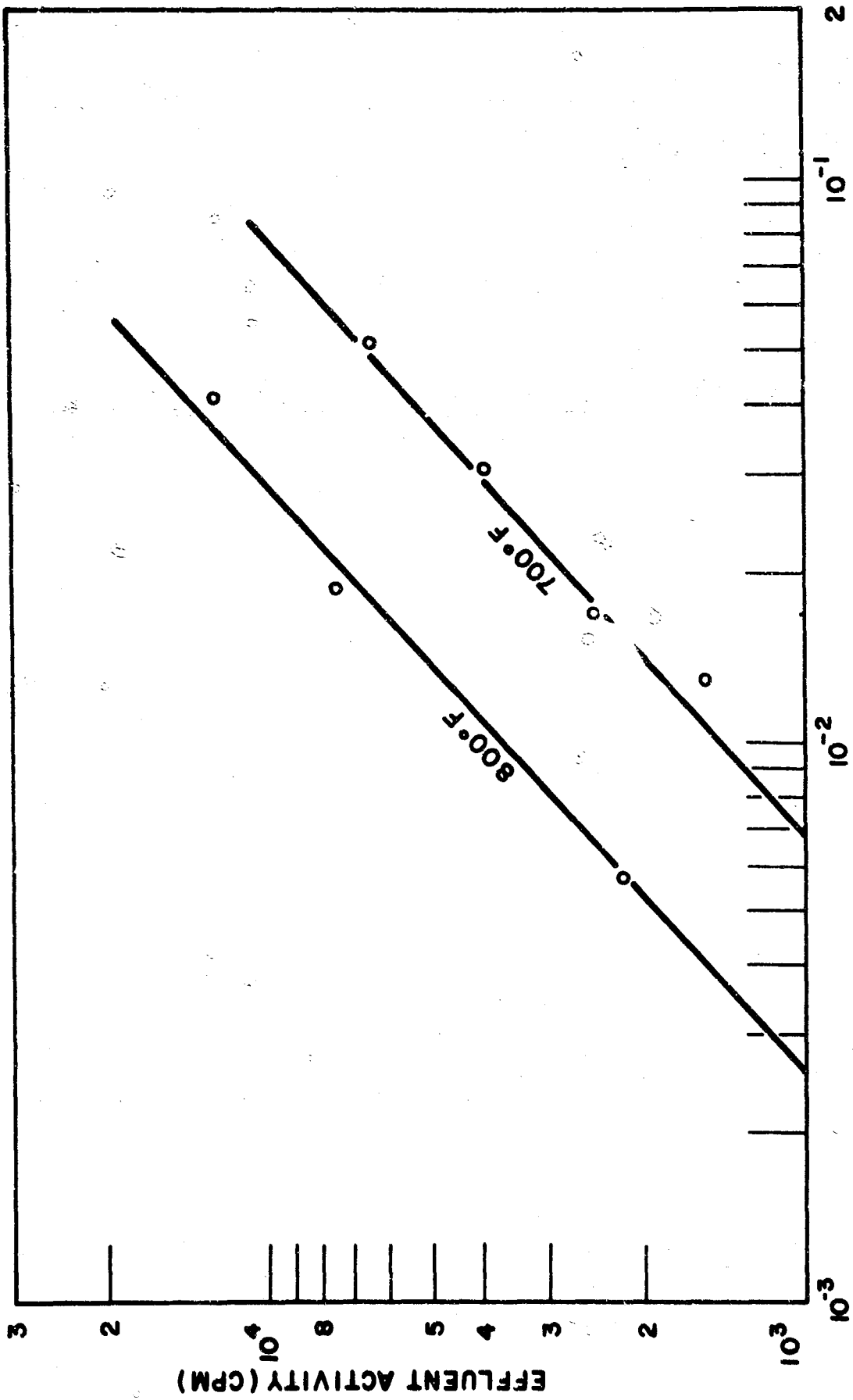

Figure 4. Response of $\text{PtO}_2\text{:Kr}^{85}\text{-Al}_2\text{O}_3$ at 700°F and 800°F to JP-6 Vapors

several additional experiments were conducted by passing the JP-6 vapors through closed systems of 3/8" quartz tubing and 3/8" stainless steel tubing contained in the heated test chamber. As before, the exit fuel concentrations from the test systems were monitored with kryptonated platinum dioxide maintained at room temperature. The results of all three tests, i. e., the JP-6 fuel vapors directly into the stainless steel lined chamber, and the closed quartz and stainless steel systems, are shown in Figure 5 for comparative purposes. In all three investigations the flow rate (250 cc/min), JP-6 vapor concentration (0.15% by wgt) and the kryptonate sensor temperature (70° F) were kept constant.

From Figure 5, it can be seen that for the quartz and stainless steel tubes, a constant effluent signal is obtained from room temperature to 700° F. As the temperature is increased the signal increases until at a temperature of 800° F the signal once again remains constant until a temperature of 1200° F is achieved. At this point the signal increased rapidly with temperature. The results obtained with the closed quartz and stainless steel tubes are almost identical in magnitude and shape, indicating that the decomposition or oxidation of the fuel occurs identically on the walls of both these materials under the conditions of the experiments. However, when the JP-6 fuel is exposed to the walls of the entire environmental chamber, a higher signal is obtained at all temperatures above 650° F.

The increase in sensitivity occurring in the temperature ranges 700 to 800° F and above 1200° F is believed to be due to the partial oxidation of JP-6 fuel into aldehydes, ketones and other products. These products probably react more efficiently with the kryptonated platinum dioxide due to their greater reducing power. Since the signal obtained from the JP-6 fuel exposed directly to the stainless steel lined chamber is higher than the closed systems, a greater percent conversion of the JP-6 fuel to partially oxidized products must occur under these conditions. This is probably due to the longer residence time of the JP-6 in this large chamber (3.7 liters) in comparison to the residence time in the quartz and stainless steel tubes.

In order to verify the fact that composition changes of the JP-6 fuel were indeed occurring as the temperature was elevated, vapors of the fuel at room temperature, 750° F and 1200° F were collected and subjected to gas chromatographic analysis. The gas chromatographic spectrum for the vapors collected at room temperature is shown in Figure 6. No attempt was made to actually identify any of the peaks shown. The fuel itself is a complex mixture of hydrocarbons, and any analysis would involve considerable time and effort. The spectra of the samples collected at 750° F and 1200° F showed similar peaks; however, the ratio of these peaks were significantly altered. In Table 2 are shown the relative heights of the peaks in terms of peak height to total area of the spectrum. Every peak showed a change (with the possible exception of number 15) indicating that the composition of the fuel did indeed change as the temperature was elevated.

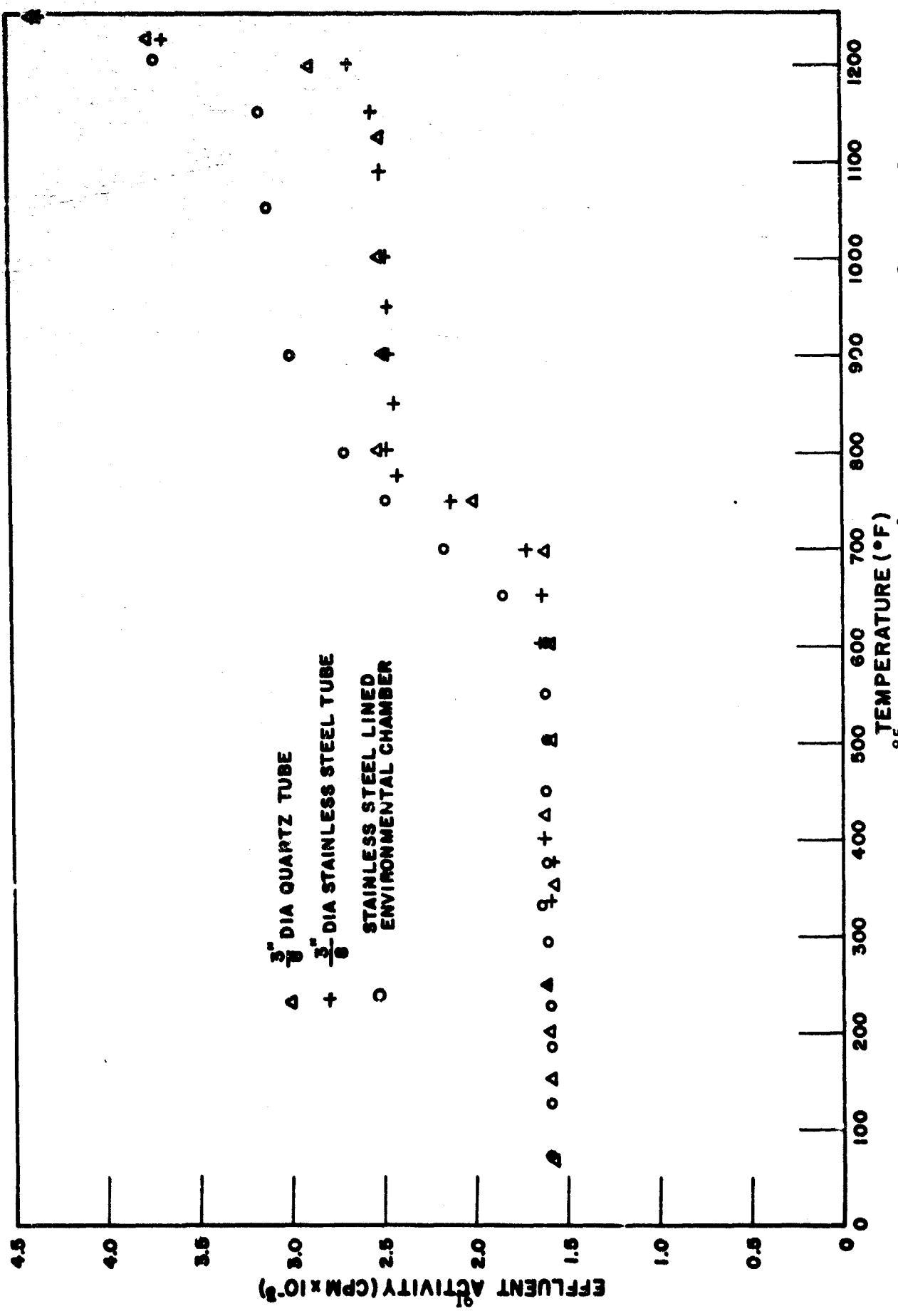

Figure 5. Response of PtO₂; Kr⁸⁵-Al₂O₃ Sensors (70°F) to JP-6 Vapors at 70°F to 1250°F

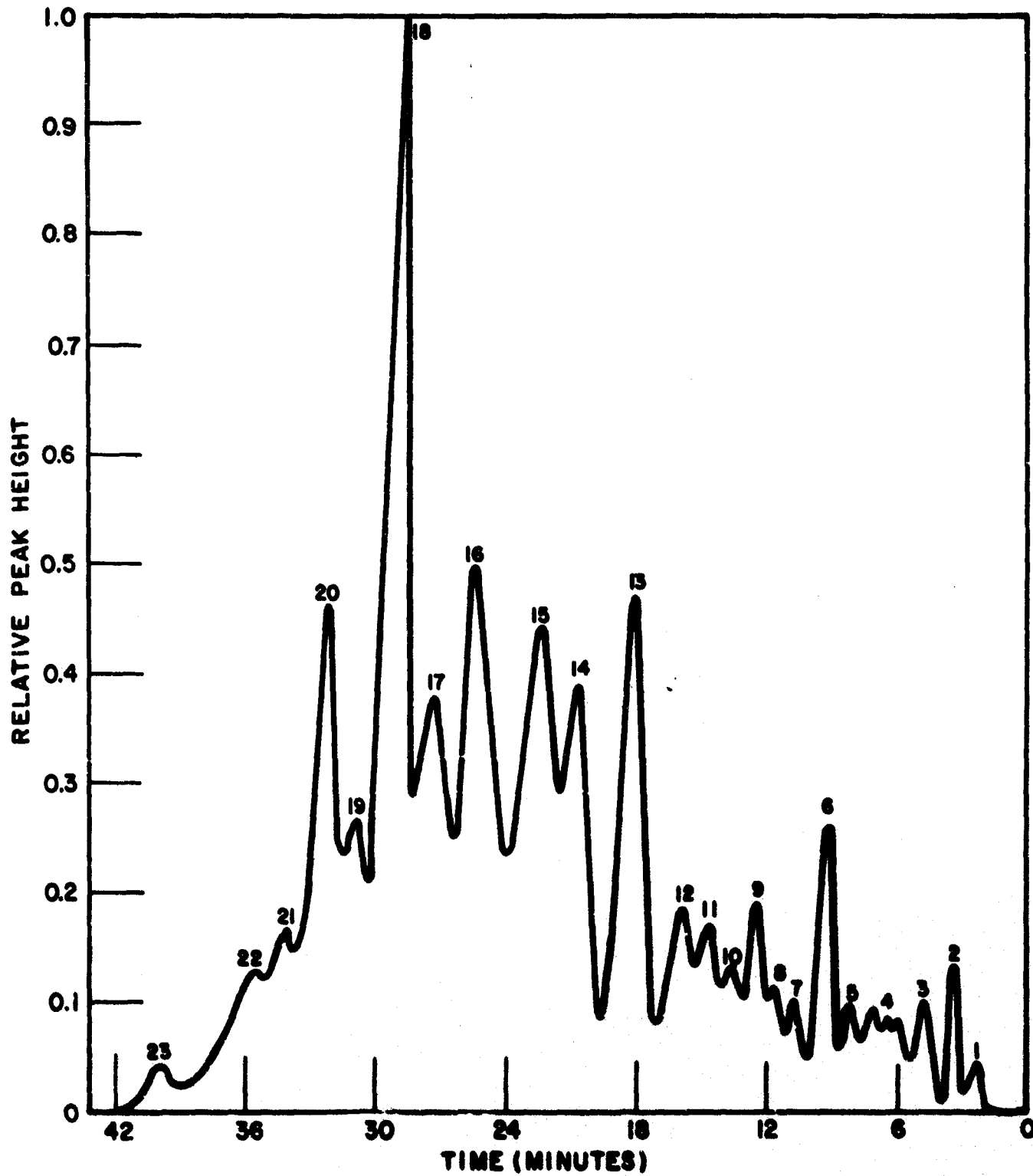

Figure 6. Gas Chromatograph of JP-6 Vapors Collected at 70°F

Table II

Gas Chromatographic Results of JP-6 Vapors Collected at 70°F,
750°F and 1200°F

<u>Peak No.</u>	<u>Peak Hgt</u> <u>Area</u> <u>I (70°F)</u>	<u>Peak Hgt</u> <u>Area</u> <u>II (750°F)</u>	<u>Peak Hgt</u> <u>Area</u> <u>III (1200°F)</u>
1	.075		(2)
2	.200	.285	(2)
3	.150	.360	(2)
4	.138	.390	(2)
5	.150	.420	(2)
6	.375	.961	.128
7	.150	.390	(2)
8	.163	.420	(2)
9	.275	.721	(2)
10	.188	.480	(2)
11	.238	.511	.096
12	.263	.571	.160
13	.663	.841	.417
14	.550	.571	.352
15	.625	.571	.513
16	.700	.420	.705
17	.538	.270	.609
18	(1)	.571	1.923
19	.375	.090	.426
20	.650	.120	.641
21	.225		(2)
22	.175		(2)
23	.056		(2)

(1) Off Scale

(2) Not Measurable

From the above results, it is apparent that no significant composition changes occur at temperatures below approximately 700° F. Thus for Mach 3 type aircraft, kryptonated platinum dioxide can be used conveniently as a sensor for JP-6 fuels.

Kryptonated platinum dioxide could be used up to a maximum temperature of 800° F; however, since combustion changes occur in the fuel, an increase in signal with increasing fuel vapor temperature would be observed. Indeed, this effect would be observed for any kryptonate sensor operating at temperatures in excess of 700° F.

There are two possible approaches which could be employed to overcome this effect. For temperatures in excess of 700° F, the fuel air mixture could be passed through a hot zone and then through the kryptonate sensor, both of which would be maintained at a temperature of at least 50° F higher than the expected maximum temperature. Physically, a cell of approximately three inches long and three eighths inches in diameter could be employed. The first two inches of this cell would be the hot zone and the final inch would contain the kryptonate sensor.

Alternatively, it may be possible to use the kryptonate sensor alone, without the hot zone area. Although the response of the sensor will change with increasing vapor temperature, the actual response obtained may be more representative of the explosive limit of the gas. Since composition changes of the fuel occur, then it would be expected that the lower explosive limit of the fuel would also change. In view of the fact that an increased reduction of the kryptonate sensor occurs as the fuel vapor temperature is increased, then the partial oxidation products must be more reactive than the original JP-6 vapors. Since these oxidation products are more reactive, it is probable that the lower explosive limit of these vapors would be considerably lower than the original JP-6 vapors, and would decrease with increasing temperature. Thus, the signal observed with the kryptonate sensor could be calibrated directly in terms of equivalent explosive hazard and would be independent of the composition of the gas and hence the vapor temperature.

d. Investigation of Kryptonated Sources for JP-6 Detection in Mach 4 to Mach 6 Type Aircraft

As discussed above, kryptonated platinum dioxide is an excellent sensor for JP-6 fuel at temperatures up to 800° F. However, since $\text{PtO}_2 \cdot \text{Kr}^{85}$ decomposes at 842° F it cannot be used for advanced aircraft with a Mach 4 or high capability.

An investigation was conducted to determine if a kryptonated sensor could be developed which would detect JP-6 at temperatures greater than 800° F. A large number of kryptonated metal oxides with melting or decomposition points greater than 1300° F were investigated. The most successful of these

materials was kryptonated palladium oxide.

Palladium oxide was kryptonated by the high temperature, high pressure diffusion technique. For a standard kryptonating time of two days, a specific activity of $.08 \mu\text{c}/\text{mg}$ was attained.

This specific activity was somewhat lower than normally obtained with powders of this type run under identical kryptonating conditions. However, sufficient activity was available to perform an evaluation as to the ability of the kryptonated palladium oxide to detect JP-6 fuel.

The kryptonated palladium oxide was loaded in the sensor cell, which in turn was mounted inside the environmental test chamber previously described. JP-6 fuel at a concentration of 0.10% by weight was passed through the quartz tube and over the kryptonate. The environmental chamber was varied from 750° to 1200° F. Once again the JP-6 vapor temperature inlet to the sensor cell was monitored continuously to insure that the JP-6 vapors were at the same temperature as the environmental chamber. The kryptonate source temperature was maintained at 1300° F, i. e., 100° F higher than the maximum environmental temperature.

Considerable care was taken to insure that the kryptonate sensor temperature was maintained constant, nevertheless, variation in signals were obtained at any constant JP-6 concentration. Referring back to Figure 5, the sensitivity (controlled by the vapor composition) changes rapidly with temperature at temperatures above 1200° F. A change in temperature from 1200° F to 1250° F results in a 50% increase in signal. Even a 10° F fluctuation in temperature at 1250° F can result in a 10% or greater deviation in signal. With the particular temperature measuring device (chromel-alumel thermocouple and Sim-Ply-Trol readout) the accuracy is estimated at $\pm 25^{\circ}$ F. Thus a 25% change in signal is not surprising.

Nevertheless, it was possible to obtain a reasonable sensitivity value for the kryptonated palladium oxide. The average value for the release in activity obtained under the conditions of the experiments described above corresponded to a sensitivity of 800 cpm for 0.1% JP-6 fuel by weight in air.

The sensitivity attained is sufficient to detect JP-6 at all the required temperatures (from Mach 3 to Mach 6 capability aircraft). However, kryptonated palladium oxide should be capable of detecting considerably lower JP-6 concentrations than indicated by the above experiments. As mentioned above, in order to determine the optimum host material for JP-6 detection at higher temperatures, it was necessary to kryptonate a great number of materials. Thus long kryptonating times, necessary for high specific activity samples, were not possible. As a result, the specific activity of the kryptonated palladium oxide was only $.08 \mu\text{c}/\text{mg}$. This specific activity is a factor of 23 lower than the specific activity of the kryptonated platinum dioxide discussed previously. By kryptonating this palladium oxide to this relatively

high level (achieved by utilizing kryptonating times of the order of two weeks), an increase in this specific activity by this factor of 23 can be obtained. Thus the sensitivity would be approximately 18,000 cpm to 0.1% JP-6 by weight in air. With a radiation detector background of 100 cpm, the kryptonated palladium oxide should be capable of detecting 0.001% by weight of JP-6 vapors in air at atmospheric pressure.

3. Hydrogen

The detection of hydrogen in air utilizing homogeneously kryptonated platinum dioxide at temperatures up to 840°F has been well established. The main purpose of the current evaluation was to ascertain if kryptonated sensors could be developed that would detect hydrogen at temperatures in excess of 1300°F.

The most important factor to consider at these high temperature conditions is that hydrogen may not exist in the presence of oxygen at these temperatures. Catalytic combustion on hot chamber walls could lead to immediate reaction with a subsequent disappearance of the hydrogen due to the formation of water. An investigation was then conducted to determine if this high temperature combustion did indeed occur.

A simple test apparatus was constructed to determine the effect of hot surfaces on the hydrogen-oxygen reaction. Hydrogen gas at various concentrations in air was first passed through an aluminum oxide-kryptonated platinum dioxide detection cell maintained at a constant operating temperature of 380°F. The hot zone consisted of 3/8" quartz tubing encompassed by an oven. The temperature in this tube could be varied from room temperature to 1500°F. The hot zone and the detector cell were connected by approximately two feet of glass tubing. This length of tubing proved satisfactory to reduce the gas temperature below the 380°F operating temperature of the sensor cell. This apparatus is shown in Figure 7.

The first hot zone material investigated was quartz. Hydrogen, at a concentration of 0.5% in air was passed through the hot zone as the temperature of the hot zone was varied from room temperature to 1500°F. Any hydrogen surviving the hot zone could be detected with the platinum dioxide kryptonate sensor maintained at its constant temperature of 380°F. The results of this investigation are shown in Figure 8. As can be seen from this curve, the hydrogen concentration remains constant until a hot zone temperature of approximately 1200°F is reached. Above this temperature, the amount of hydrogen surviving the hot zone rapidly decreases until at temperature of 1350°F, the hydrogen concentration has been reduced to less than 20 ppm (the lower detection level of the PtO₂. Kr⁸⁵ sensor under these particular operating conditions).

Similar experiments were conducted using stainless steel and copper tubes in place of the quartz, with hydrogen concentrations varying from

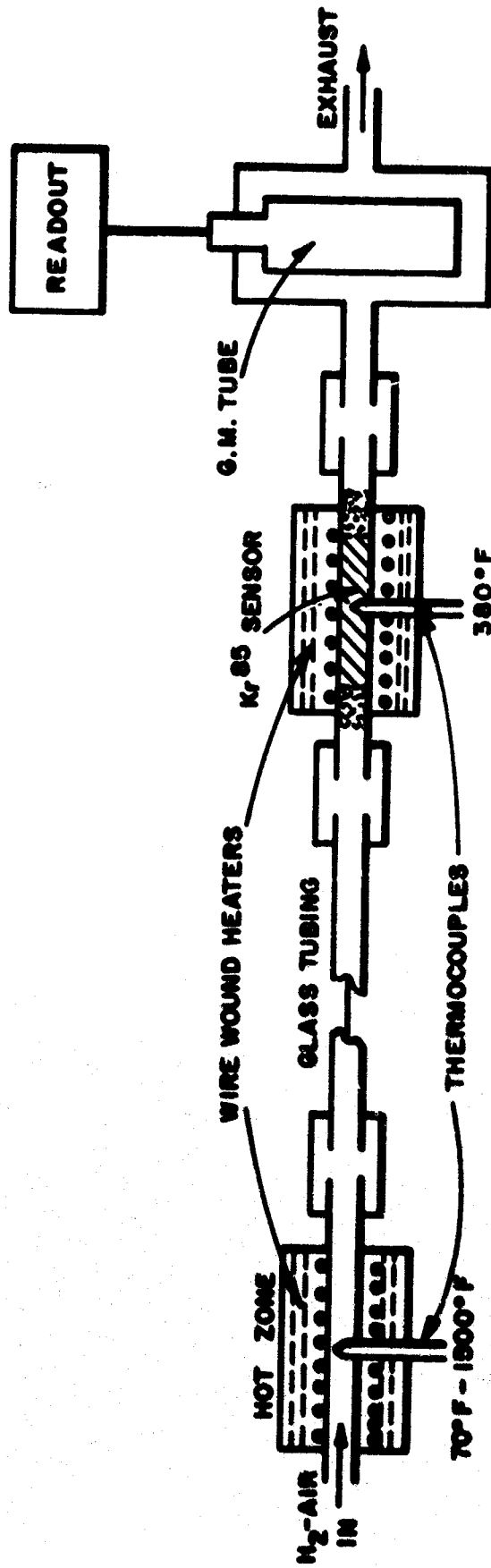

Figure 7. Test System for Determining the Effect of Hot Surfaces on the H_2-O_2 Reaction

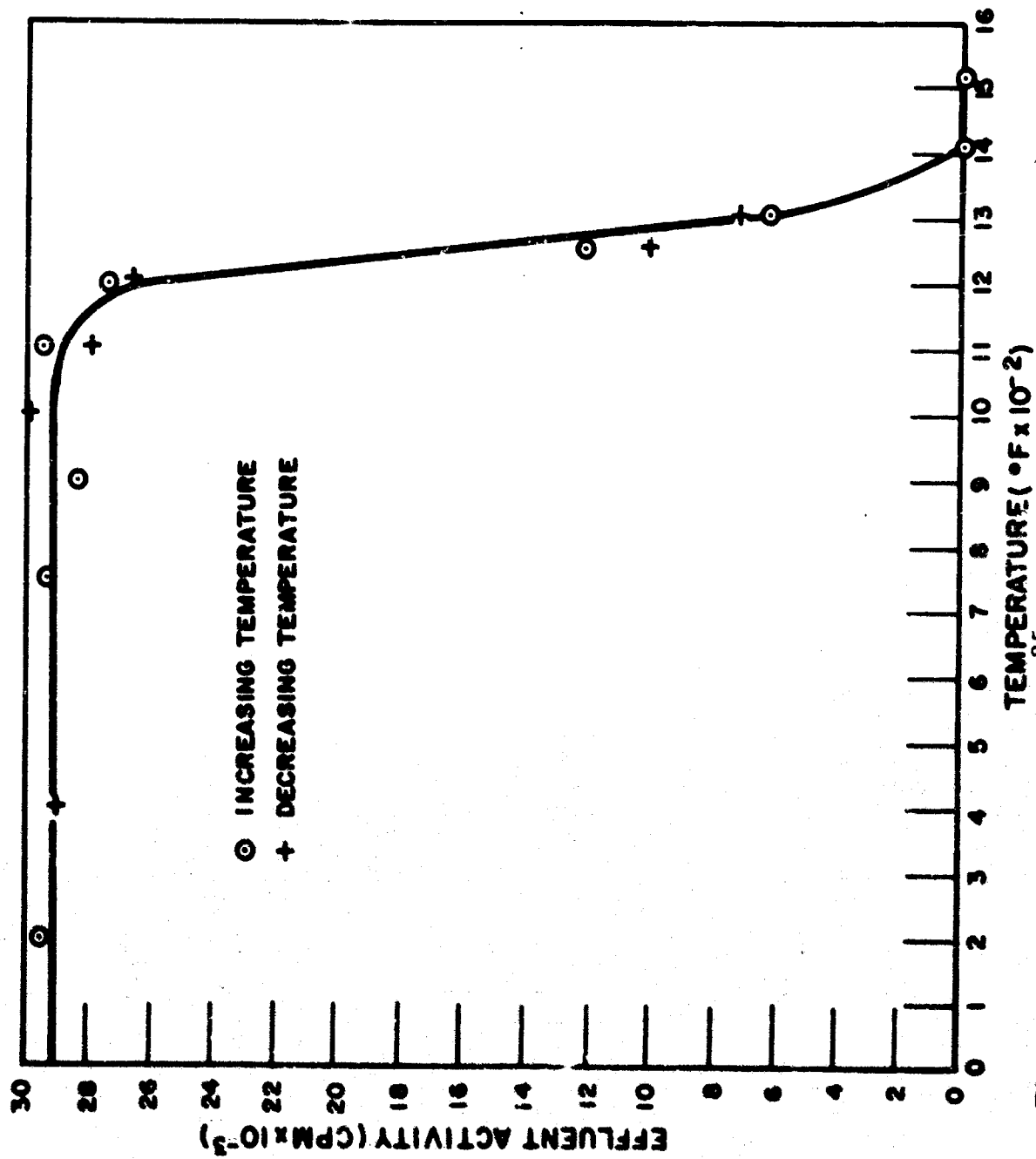

Figure 8. Response of PtO₂·Kr⁸⁵ to H₂ at Various H₂ Vapor Temperatures

0.1 to 1.0% by volume. In all cases the hydrogen gas concentration remained constant until a hot zone temperature of approximately 1300° F was attained, where once again the hydrogen concentration rapidly decreased to essentially zero with increasing temperature.

Experiments were then conducted utilizing the environmental chamber previously described. Although the area to volume ratio of this chamber is a factor of ten less than the area to volume ratio of the 3/8" diameter tubing, results indicated that once again the hydrogen was almost completely oxidized to water vapor at temperature greater than 1300° F.

The above experiments indicate that complete, or almost complete combustion of the hydrogen vapors with the ambient oxygen occur on the chamber walls, independent of the initial hydrogen concentration over the range studied. On the basis of these experiments, it is concluded that, in general, hydrogen will not exist at these high temperatures in the actual compartments of an advanced type aircraft. Such a conclusion is conditional upon precise knowledge of the materials of construction, the actual geometry and the lack of a stoichiometric excess of hydrogen. However, the above experiments indicate that the presence of hydrogen at temperatures greater than 1300° F would be unlikely.

Despite the experimental difficulties in obtaining hydrogen vapors known concentrations at temperatures greater than 1300° F, it was possible to demonstrate that kryptonated sensors could be developed to detect this gas at these temperatures if the gas itself were not destroyed on the hot chamber walls. This evidence was obtained by passing known concentrations of hydrogen gas in air at room temperature directly through a kryptonated sensor maintained at temperatures in excess of 1300° F. Although it was known that a considerable fraction of the hydrogen would be destroyed on the sensor walls, it was believed that sufficient hydrogen would make direct contact with the kryptonate to cause a significant reaction.

The first metal oxide tried was kryptonated palladium oxide. Since this oxide has a melting point of 1380° F and reacts similarly to platinum dioxide, it was believed that a significant reaction would occur at the elevated temperatures. However, repeated experiments, utilizing different molecular barrier type materials (Fe_2O_3 , Al_2O_3) resulted in no response to hydrogen. These negative results were probably due to the complete combustion of hydrogen and oxygen on the surface of the sensor at these high temperatures.

What was then necessary was to obtain an oxide which would not decompose or melt at temperatures less than 1800° F and which would preferentially be reduced by hydrogen rather than cause the catalytic oxidation of this gas.

Many kryptonated oxides were tried. The most successful was

kryptonated copper oxide. At an operating temperature of 1500°F, CuO. Kr⁸⁵ with a specific activity of 0.5 μc/mg indicated a sensitivity of 1200 cpm for 1% H₂ in air. This sensitivity is considerably lower than is normally obtained with PtO₂. Kr⁸⁵ at lower temperature (150,000 cpm per 0.1% H₂ at 350°C) and is partially attributable to the lower specific activity of the CuO. Kr⁸⁵. Undoubtedly, the major factor influencing the sensitivity is the actual fraction of hydrogen which combusts on the cell walls. Since a considerable fraction of the original 1% hydrogen is converted to water vapor, only the small remaining fraction is available for detection by the kryptonate sensor.

Attempts were made to increase this sensitivity by employing molecular barrier type material. However, every barrier tried only served to reduce the sensitivity of the system. This probably occurred because the hydrogen did not have sufficient time to diffuse through the barrier before oxidation could occur.

The signal of 1200 cpm for 1.0% H₂ with kryptonated CuO did not vary significantly with temperature in the range of 1200°F to 1800°F. This constant reaction rate with increasing temperature is difficult to explain without a thorough evaluation of the effects of flow rates, concentrations and the actual amount of hydrogen reacting with the sensor at the various temperatures.

It should be pointed out that the sensitivity of CuO. Kr⁸⁵ discussed above was obtained with hydrogen in air. In the absence of oxygen, extremely rapid and very sensitive response to hydrogen is obtained with copper oxide as well as with many other oxides (Fe₂O₃, Cr₂O₃). For example, at an operating temperature of 1450°F kryptonated copper oxide showed a response of 160,000 cpm to a 1% hydrogen concentration at a flow rate of 2 liters/min. Thus in the absence of oxygen, hydrogen can be readily detected at concentrations down to 10 ppm at all the required temperatures.

Although the sensitivity is considerably reduced in the presence of oxygen; by utilizing kryptonated copper oxide with a specific activity of approximately 1.0 μc/mg, it should be possible to detect hydrogen concentrations of the order of .005% or less at all the required temperatures.

Thus with CuO. Kr⁸⁵, hydrogen can be detected at the temperatures which would be expected in Mach 7 and Mach 8 type advanced aircraft and indeed up to a maximum temperature of 1830°F, 50° below the decomposition point of CuO. However, this estimate assumes that hydrogen will exist in the compartments of the advanced type aircraft at these high temperatures. The results obtained during the experimentation described above appear to contradict this assumption.

4. Discussion of Results and General Evaluation of the Kryptonate Technique.

The experimental effort described above was to determine if kryptonated sensors could be developed that would detect JP-6 fuel and hydrogen vapors at the high ambient temperatures. It has been shown that kryptonated platinum dioxide can detect JP-6 vapors at the required concentrations at all temperatures from -60°F to 700°F . In order to eliminate the effect of ambient temperature fluctuation, the platinum dioxide kryptonate must be operated at a temperature 50°F greater than the expected maximum ambient temperature. For temperatures greater than 700°F , kryptonated palladium oxide is satisfactory for the detection of JP-6. However, since apparent fuel composition changes occur at temperatures above 700°F it would be necessary to utilize a combination cell system consisting of a hot zone and the kryptonated palladium oxide. In this manner the partial oxidation of the fuel is controlled so that a constant effluent activity would be attained at any constant JP-6 vapor concentration. Alternatively, since it would be expected that the lower explosive limit of the fuel vapor would decrease with increasing temperature (i. e., as more reactive vapor constituents are formed) it may be possible to calibrate the response of the sensor directly in terms of equivalent explosive hazard, thus negating the use of a hot zone.

The results indicate that hydrogen will probably not exist in the presence of oxygen at temperatures in excess of 1200°F . However, since this combustion depends on many factors including surface materials, flow rates, pressures, etc., it is possible that under certain conditions hydrogen will exist in the hot compartments of advanced aircraft. On this basis, kryptonated copper oxide can be used to detect its presence at all the required temperatures.

The kryptonate technique indeed could be used to detect the combustion products of the fuels, viz, water. It has been shown that kryptonated calcium carbide is sensitive to water vapor. Thus, the technique could be used to detect hydrogen at the high temperatures even if complete combustion should occur. However, this sensor for water vapor would require a considerable developmental effort in order to meet the program requirements. The aluminum oxide hygrometer discussed in section D is believed to be more satisfactory for this purpose.

The ability of the kryptonated sensors to meet the other program requirements of pressure, response time and selectivity has been well established. A brief discussion concerning these parameters is presented below.

a. Pressure

The kryptonates are true mass sensors since their sensitivity is based directly on the mass of vapor reacting with the kryptonated homolog. Thus the only effect of pressure on the operation of the kryptonate sensor is that of effectively reducing the concentration of the vapor of interest. The question of the ability of the kryptonate sensor to operate at reduced pressures is then reduced to a question of sensitivity.

For kryptonated palladium oxide at an operating temperature of 1250° F, the lower limit of sensitivity is of the order of 0.001% by weight of JP-6 vapors in air at atmospheric pressure. Assuming a molecular weight of 150 for JP-6 fuel, this weight percent corresponds to approximately .0002% by volume. Assuming it is desired to detect 0.15% by volume of JP-6 fuels at all pressures from sea level to 100,000 feet, the lowest effective concentration will occur at 100,000 feet where the ambient pressure is 0.01 atm. At this altitude a 0.15% by volume concentration would be effectively reduced to 0.0015%, which is a factor of sever higher than the lower limit of sensitivity of the palladium oxide sensor.

Similarly for hydrogen, utilizing kryptonated copper oxide with a specific activity of 5 μ c/mg, a response of 12,000 cpm to 1% hydrogen would be attained at an operating temperature of 1800° F. With a counter background of 100cpm, this sensor can detect .005% hydrogen at atmospheric pressures or 0.5% hydrogen at 100,000 feet.

b. Response Time

The response time of the kryptonate sensor is limited by the time for transporting the released gaseous krypton-85 to the radiation detector. At a flow rate through the sensor cell of 2 liters/minute through a tube of 1 cm diameter, a linear flow rate of approximately 1.4 feet/second would be obtained. The radiation detector could then be located a distance of approximately 7 feet for a 5 second response. Shorter distances could be used; however, the problem then becomes one of maintaining the radiation detector sufficiently cool for proper operation.

Advances are being made in the development of solid state detectors capable of withstanding high environmental temperatures. It is believed that in the relatively near future, solid state detectors will be available that can operate to 1000° F. With additional cooling of such a detector, it is believed that operation of the detector directly within the hot compartment would be possible. The detector could then be mounted in close proximity to the sensor cell, in which case the limiting factor in the response time would be the electrical time response of the circuit. These electrical time responses are typically below one second.

c. Selectivity

The selectivity of kryptonated oxides to combustible vapors has

been demonstrated and reported.⁸ The oxides investigated during the course of this program will not react with the gases likely to be encountered as contaminants in compartments of an advanced flight vehicle. Water vapor, nitrogen, oxygen and carbon dioxide have no effect on the operation or response of these kryptonated oxide sources.

C. EVALUATION OF THE INFRARED TECHNIQUE FOR COMBUSTIBLE FUEL DETECTION

1. Introduction

Another promising device for use in this application is the Infrared Explosive Vapor Detector, developed by Mine Safety Appliances Co. (ASD-TDR-62-531, October 1962). This instrument, although insensitive to hydrogen, does have the capability of detecting hydrocarbon fuel vapors at the requisite concentrations and ambient pressures.

A laboratory prototype of this device was made available to Parametrics to aid in the evaluation of this technique.

The MSA Explosive Vapor Detector is a non-dispersive open path infrared photometer, which monitors the concentration of hydrocarbon vapors by means of their absorption of infrared radiation.

For the purposes of optimizing simplicity, sensitivity, and reproducibility, the device was designed to be a reference-type system, utilizing one source and one detector, sensitized for two different wavelength bands. One band, the "signal" band, is that at which the fuel vapor absorbs, and the other, the "reference" band, is close to the former, but where the fuel vapor displays little absorption.

In order to visualize the method of operation a simplified sketch is presented in Figure 9.

The light source is a 60-watt high-intensity ($W-I_2$) incandescent lamp (filament temp $\sim 3000^\circ K$). Light from this source is beamed by a 6" ellipsoidal mirror (F. L. = 2" and 42") through the sample space. It is collected by a deep parabolic mirror ($f=0.6$) and focused onto the detector. The detector is of the pneumatic type, consisting of a hermetically sealed chamber with a thin germanium window which passes radiation in the appropriate wavelength region. It is filled with gases which absorb both in the "signal" wavelength band ($\sim 3.4\mu$) and the "reference" wavelength band ($\sim 3.0\mu$). (The sensitizing gases are isocutane and acetylene respectively). When the detector is exposed to infrared radiation in the selected wavelength regions, absorption by the fill gases results in a temperature increase, which leads to a corresponding increase in pressure. This pressure rise causes movement of a small diaphragm,

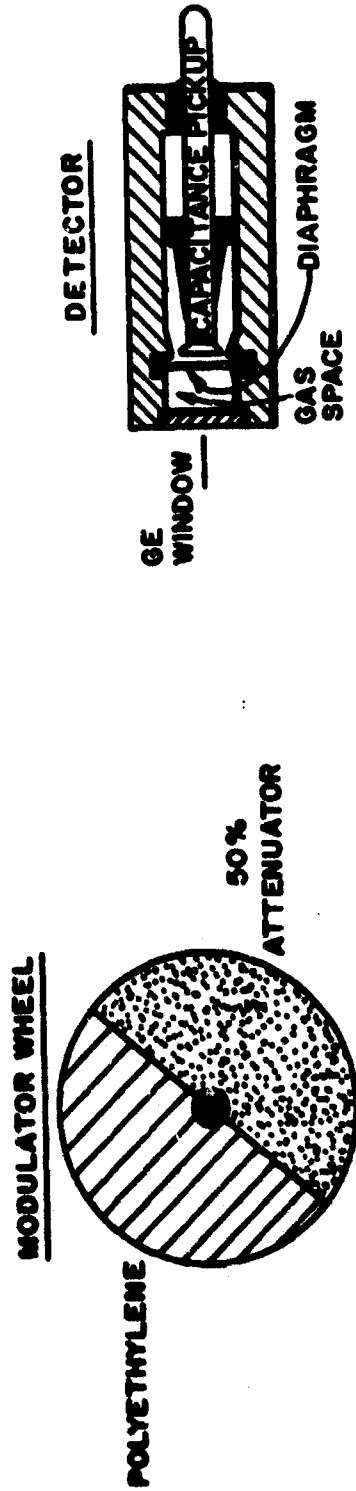
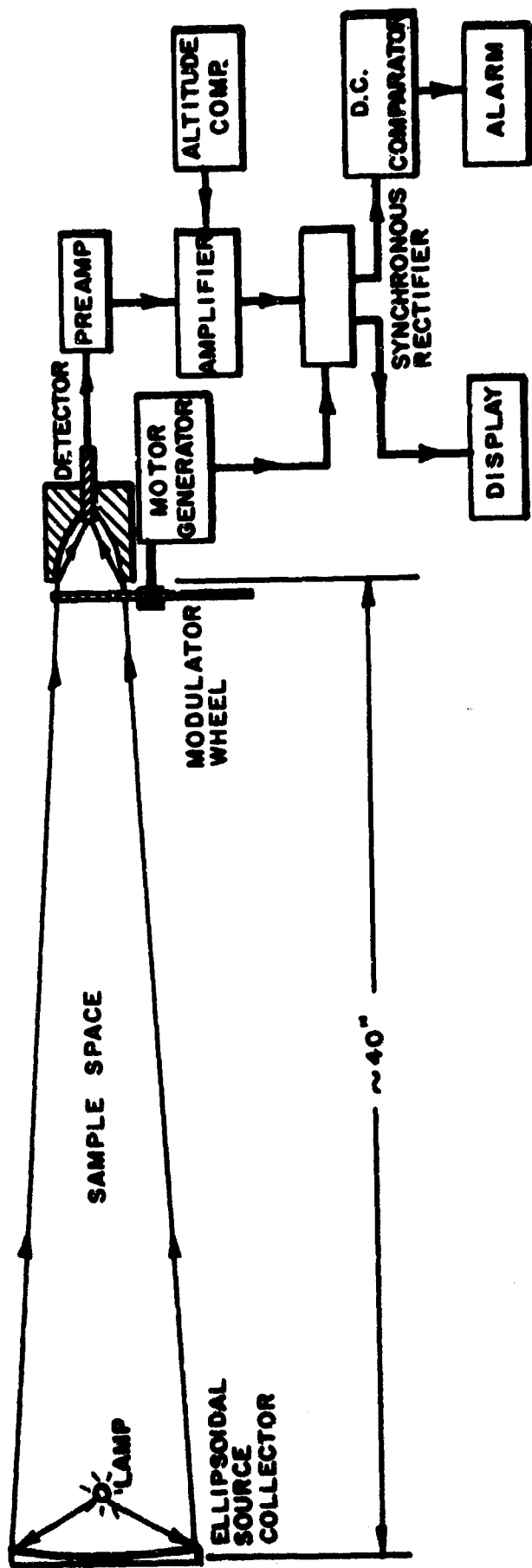

Figure 9. MSA Explosive Vapor Detector (Schematic)

and this movement is sensed by a capacitive pick-up.

Immediately in front of the detector is a rotating modulator wheel, consisting of two segments. One segment is made of polyethylene, which transmits only the reference band. The other segment is a 50% neutral attenuator, which transmits half the radiation in both the signal and reference bands. The system parameters are adjusted so that, in the absence of hydrocarbon vapors in the light path, the energy absorbed by the detector is the same regardless of which modulator segment is in the beam. If hydrocarbon vapors are present, however, the available energy in the signal band will be diminished (due to absorption by the vapor). This will cause no change during the half-cycle when the polyethylene segment is in the beam, but the detector will receive less energy when the neutral attenuator segment is in the beam. This alternating signal is then amplified, rectified, displayed, and compared with a predetermined "alarm" level.

In addition, the instrument has the capability of automatically compensating for ambient pressure from 1 atmosphere down to 0.01 atmosphere. This is necessary because a given percentage of hydrocarbon by volume corresponds to 100 times more absorption at one atmosphere than at .01 atmosphere (100,000 feet). This compensation is accomplished by appropriately varying the gain of the detector amplifier by means of a servo-type pressure transducer.

The instrument is designed to operate with a 38" path length between source and detector. For the sake of compactness and ease of handling, the prototype utilizes two parallel inclined plane mirrors to fold the light path, thus affording a shorter physical length for the instrument.

Although the instrument is designed for open-path operation, it is more convenient, in the laboratory, to have an enclosed sample chamber into which test gas mixtures can be placed. For this purpose, a 2 1/2" long test cell is located in the light path (one must make, of course, the appropriate path length corrections when using this cell).

In an attempt to simulate high temperature operation, some modifications of this prototype were made. In order not to damage the base of the instrument by resting a hot furnace upon it, the source lamp was remounted 38 inches away from the detector on a straight line, thus by-passing the diagonal mirrors, and "opening up" the folded path. This provided sufficient new space in the light path to mount a high temperature test cell, without damaging the instrument.

The cell (Figure 10) consisted of a 6" x 28" stainless steel tube, wrapped with nichrome heating elements, and appropriately insulated.

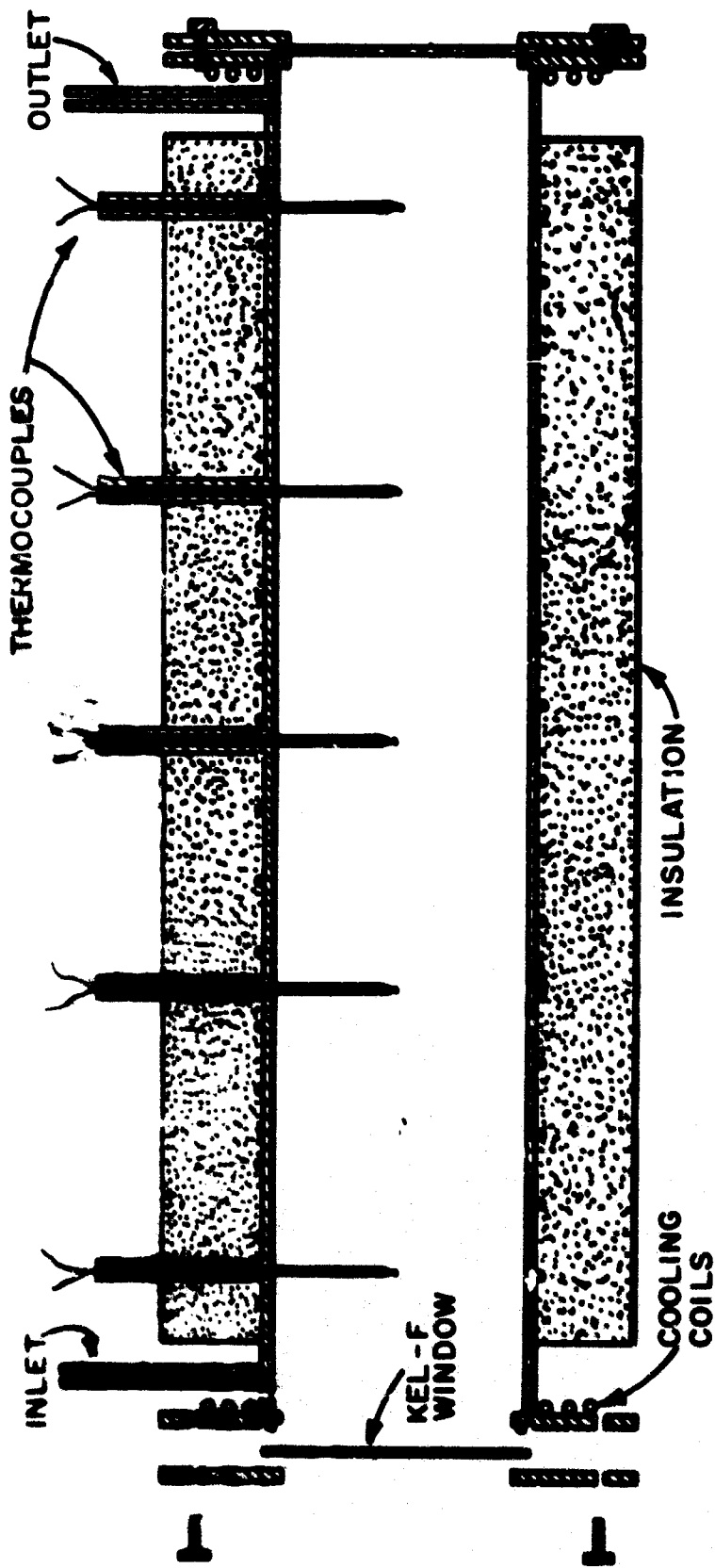

Figure 10. High-Temperature Test Cell

The tube was provided with gas inlet and exit ports, and temperatures were monitored by a series of thermocouples placed as shown. The end windows were 1/8" x 6" Kel-F discs, mounted on water-cooled flanges. Blowers were mounted externally to cool the windows as much as possible. Despite these precautions, the windows started to deform at cell temperatures higher than $\sim 500^{\circ}\text{F}$, thus limiting the operational temperature range. (The original design called for quartz windows; however the initial windows received showed spurious I-R absorption properties. As time limitations did not allow further delay, it was decided to attempt to use Kel-F despite its temperature limitations).

2. Evaluation

In attempting to evaluate this device for usage under the conditions specified, it must be borne in mind that this particular prototype was actually designed and constructed to meet somewhat different specifications, particularly with respect to concentrations and ambient temperatures, than are called for in this study. It would therefore be unfair to fault the basic technique because of any limitation exhibited by the prototype unless this limitation could be shown to be an inherent consequence of the technique. For this reason, although some experimental tests were performed with the prototype, the primary basis for our evaluation has been to pick out those problem areas which arise from the nature of the method, rather than the particular design details of the prototype.

Let us review the necessary requirements for the proposed system, and contrast them with the capabilities which have already been designed into the prototype. Where a discrepancy exists an attempt will be made to estimate whether or not the limitation may be easily overcome.

<u>Desired Capability</u>	<u>Infrared Prototype Design</u>
<u>Species Detected</u>	
JP-6 Hydrogen	JP-4
<u>Concentration Levels</u>	
JP-6 - 0.15% (volume) H ₂ - 1%	JP-4 - 0.25 - 0.5% (volume) H ₂ - insensitive
<u>Minimum Ambient Temperature</u>	
-65 ^o F	-65 ^o F

Maximum Ambient Temperature

Mach 3:	550 ^o F	
Mach 4:	850 ^o F	
Mach 5:	1100 ^o F	165 ^o F
Mach 6:	1200 ^o F	

a. Species

The first difference to be noted is that the infrared system cannot detect hydrogen. This is because hydrogen has no infrared absorption. Thus this constitutes a basic limitation of any infrared detection technique. We will hereafter, then, concern ourselves only with the possible application of this technique for hydrocarbon vapor detection.

Although this device was developed primarily as a monitor for JP-4 there is no reason why it should not respond to JP-6 vapor, as well. The infrared detector is sensitive to spectral absorption in the vicinity of 3.4 μ , which corresponds to the \equiv C-H stretching frequency; therefore the technique should be applicable to practically all compounds containing saturated hydrocarbon groups.

Of course, the degree of sensitivity will be a function of the absorption coefficient of the fuel vapor and the "match" between its absorption band and that of the detector fill gas (presently isobutane). However, we may expect that there will be little difference between JP-4 (for which the system was designed) and JP-6. Qualitative confirmation of this expectation was obtained in the following way:

A JP-6 air mixture (0.6% by weight) at atmospheric pressure was flowed through the test cell, and the signal level observed. This reading was then compared with that obtained with 0.5% (by volume) isobutane in nitrogen (simulant gas).

Unfortunately, neither the average molecular weight of JP-6 nor its vapor pressure is accurately fixed, so that the volume percentage of the mixture could not be precisely determined. However, one may make a rough estimate of the volume percentage by assigning an "average" molecular weight of 150 to JP-6. Thus, 0.6% by weight would correspond to $0.6\% \times \frac{29}{150} \approx 0.12\%$ by volume. The ratio of the signal voltages obtained with the two mixtures was:

$$\frac{V(0.12\% \text{ JP-6})}{V(0.5\% \text{ isobutane})} = \frac{1.3}{1.9} \quad (3)$$

Thus, the apparent relative sensitivity of the instrument to equal volume percentages of isobutane and JP-6 would be:

$$\frac{\text{JP-6}}{\text{C}_4\text{H}_{10}} \approx \frac{1.3/.12}{1.9/.5} \approx 2.8 \quad (4)$$

The original report describing the instrument indicates that its sensitivities for isobutane and JP-4 are roughly equal.¹³ Therefore, we may safely assume that, although the instrument was designed for JP-4, it could, with little or no modification of parameters, be used equally as well with JP-6.

b. Concentration Levels

The desired detection level for JP-6 is given as 1/4 of the LEL or 0.15% by volume. The prototype instrument has been designed to alarm between 0.25 and 0.5% JP-4 by volume. It appears that there would be little effort entailed in readjusting the gain settings and alarm parameters to the new requirements, especially in view of the apparent higher sensitivity for JP-6 than for JP-4. Certainly the present requirements should necessitate no major redesign in terms of path length, optics, source intensity, etc.

c. Ambient Temperature

It is by now obvious that the major limitations imposed on this system will be those due to the extreme high-temperature environment in which the instrument must operate. The problems introduced by these high temperatures fall into several categories, some of which are quite general for any detection system, and others which are specifically associated with an infra red system.

1) Effect on the Vapor Composition

This effect is discussed in more detail elsewhere in this report. In essence, it appears that in contact with hot surfaces, hydrocarbon vapors undergo chemical decomposition. This is not a surprising finding, but it does lead to an ambiguity in defining the sensitivity specifications for an instrument; e. g. shall the device measure only whatever JP-6 vapor is actually present; or (more desirable) shall it measure the results of vapor leakage, regardless of what the pyrolysis products may be. This ambiguity is present, of course, for any contemplated detection system.

In the case of the infrared system, this may or may not be a major problem, depending on the particular reactions which the hydrocarbon vapors undergo. If they are completely oxidized to CO, CO₂ and H₂O, then the instrument will obviously not detect them. On the other hand, it seems reasonable to believe that although chemical changes

occur, oxidation will by no means be complete (especially at low pressures) and that the product molecules will still retain most of their alkane-type C-H bonds. If this is the case, then the instrument could still have adequate sensitivity.

It is difficult to evaluate the extent of this problem, in view of the many parameters which may have a bearing on it, such as: wall materials, compartment size, circulation patterns, etc.

2) Thermal Expansion

If the compartment being monitored is vented, then variations in the temperature of the gas contained within it will lead to corresponding expansion and/ or contraction of the gas. With hydrocarbon vapor present at any given volume percentage, and at any given ambient pressure, this will cause variation in the actual absolute vapor concentration present. This effect is illustrated in Figure 11 which shows, for a fixed volume percentage, the relative vapor densities at various temperatures. It can be seen that over the range of expected temperatures for hydrocarbon fuels (-65°F to 1200°F) the possible variation covers approximately a factor of four!

Compensation for this phenomenon could probably be supplied by arranging for a temperature sensor which could appropriately control the gain of the instrument, in a fashion similar to that already used for pressure compensation.

3) Effect of Temperature on the LEL

It has been stated that a useful rule of thumb is that the LEL for hydrocarbon vapors decreases by about 8% for each 100°F increase in temperature. This would imply about a factor of 2 decrease in the LEL at 1200°F . Although the specifications call for a fixed alarm level at 0.15% by volume, it might be desirable to consider either varying the alarm level as a function of temperature or, with a fixed alarm level, varying the instrument sensitivity (as mentioned above) via a temperature sensor, to compensate for this effect.

4) Effect on Components

With a few exceptions, the limitations on components introduced by the extreme high-temperature environment will be those that apply generally to any type of detection system which might be postulated. With respect to the electronic components, the system uses fairly standard circuitry, e.g. preamplifier, variable gain amplifiers, rectifier, etc. It seems certain that the present "state of the art" in these components will not allow them to be directly exposed to the

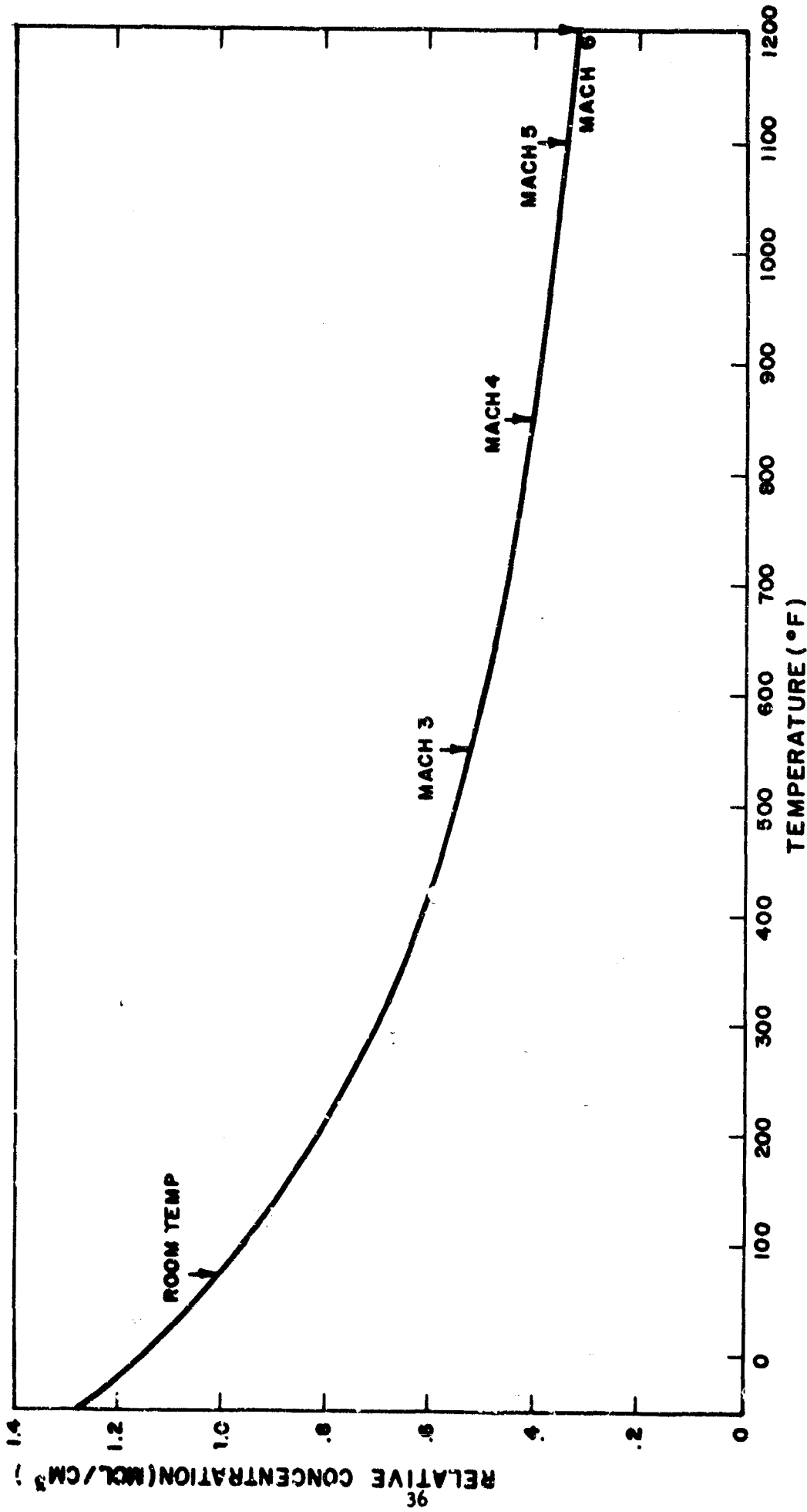

Figure 11. Variation in Concentration with Temperature (Vented Chambers)

expected ambient temperatures, and that a means for keeping them cool will have to be devised. The bulk of the electronics, of course, does not necessarily have to be in close physical proximity to the space being monitored. As there will undoubtedly be other electronic systems aboard the aircraft, whatever methods may be devised for keeping these operative will obviously suffice for this system as well.

The preamplifier stage, however, should be as close as possible to the infrared detector to minimize noise and pickup problems. This leads to the problem of whether the detector itself can be exposed to temperatures as high as 1200° F. It is quite likely that the sensitizing gases (i-butane and acetylene) will undergo thermal degradation reactions under these conditions. In addition excessive heating of the detector might distort or damage the germanium window or the thin diaphragm. Thus, the detector, also, will probably have to be kept cool in some manner.

Although the lamp, source mirror, modulator, collector and detector must have optical access to the space being monitored, this does not rule out the possibility of physical (and thermal) separation by means of windows, auxiliary mirrors, etc. This, of course, would tend to make the overall system more complex in terms of alignment, necessary space and weight, etc. As the heat loads cannot really be estimated at this time, it is difficult to predict whether or not it would be feasible to cool all sensitive optical components.

5) Effect on Infrared Absorption Coefficients

In general, the infrared absorption peaks of the JP-6 vapor will be expected to decrease in amplitude, and broaden, as the gas temperature increases. As the instrument sensitivity is a function of the degree of overlap between the fineline structures of the JP-6 vapor and the sensitizing gas within the detector, and as these undoubtedly do not completely and exactly coincide, even at low temperatures, it is impossible to predict the effect on instrument sensitivity of operating the system at high temperature.

Evaluation of this effect can only be done on an empirical basis, by measuring any changes in signal caused by heating a hydrocarbon contained in the sample space, (and, of course, correcting for the other thermal effects noted in this section). An attempt was made to do this; however temperatures higher than ~500° F were not attained, and time was not available in which to redesign the apparatus. We may state that at this temperature, at least, no large change in sensitivity was evident.

6) Thermal Background

An effect which was apparent, even at quite moderate temperatures, was that due to "thermal background". This arises from the thermal radiation emitted by the hot walls of the surrounding container. This radiation changes the relative amounts of energy "seen" by the modulator-detector in the reference and signal wavelength bands, and, in effect alters the "zero" of the instrument.

One may understand this phenomenon by considering the following simplified picture: Assume that the sensitizing gases in the detector absorb all incident energy only in the reference and signal bands. Let the reference band be located at wavelength λ_r , and have a finite width $\Delta\lambda_r$. Similarly, let λ_s and $\Delta\lambda_s$ characterize the signal band. Let the energy emitted by the lamp filament (at temperature T_L) in the reference band be proportional to $W(\lambda_r T_L) \Delta\lambda_r$ watts/cm² where $W(\lambda T)$ is the usual Planck expression for black-body radiation. Similarly $W(\lambda_s T_L) \Delta\lambda_s$ is proportional to the energy emitted in the signal band.

In the absence of absorbing gas in the sample space, the lamp energy falling on the modulator-detector will be:

$$E_L^0 = A_L \left[W(\lambda_r T_L) \Delta\lambda_r + W(\lambda_s T_L) \Delta\lambda_s \right] \quad (5)$$

where A_L is an "effective" lamp area, encompassing lamp size, emissivity, and the optical efficiency of the instrument.

If one segment of the modulator disc absorbs all energy in the signal band, then the energy reaching the detector during this half-cycle is:

$$E_{1L}^0 = A_L W(\lambda_r T_L) \Delta\lambda_r \quad (6)$$

During the other half-cycle, the modulator acts as a 50 per cent attenuator, and the energy received by the detector is:

$$E_{2L}^0 = 0.5 A_L \left[W(\lambda_r T_L) \Delta\lambda_r + W(\lambda_s T_L) \Delta\lambda_s \right] \quad (7)$$

$$S = E_1 - E_2 \quad (8)$$

The instrument parameters are such that with no hydrocarbon present this difference is zero.

$$S_L^0 = E_{1L}^0 - E_{2L}^0 = 0.5 A_L \left[W(\lambda_r T_L) \Delta\lambda_r - W(\lambda_s T_L) \Delta\lambda_s \right] = 0 \quad (9)$$

$$\therefore W(\lambda_r T_L) \Delta\lambda_r = W(\lambda_s T_L) \Delta\lambda_s \quad (10)$$

If the instrument, in addition, "sees" background radiation from the hot walls, we may write the analogous relations:

$$E_{1B}^0 = A_B W(\lambda_r T_B) \Delta\lambda_r \quad (11)$$

$$E_{2B}^0 = 0.5 A_B \left[W(\lambda_r T_B) \Delta\lambda_r + W(\lambda_s T_B) \Delta\lambda_s \right] \quad (12)$$

$$S_B^0 = 0.5 A_B \left[W(\lambda_r T_B) \Delta\lambda_r - W(\lambda_s T_B) \Delta\lambda_s \right] \quad (13)$$

where A_B = effective radiating area of hot "background"

T_B = background temperature.

Substituting for $\Delta\lambda_r$ from equation (10)

$$S_B^0 = 0.5 A_B \left[\frac{W(\lambda_r T_B) W(\lambda_s T_L) \Delta\lambda_s}{W(\lambda_r T_L)} - W(\lambda_s T_B) \Delta\lambda_s \right] \quad (14)$$

$$S_B^0 = 0.5 A_B W(\lambda_r T_B) \Delta\lambda_s \left[\frac{W(\lambda_s T_L)}{W(\lambda_r T_L)} - \frac{W(\lambda_s T_B)}{W(\lambda_r T_B)} \right] \quad (15)$$

The ratio $W(\lambda_r T)/W(\lambda_s T)$ is a function of T only, and, therefore, if $T_B \neq T_L$, the bracketed portion of equation (15) will be non-zero, leading to a finite background signal.

We must now attempt to determine whether this "background signal" (which, in theory, is present to some extent at all temperatures) will be significant with respect to the signal levels due to hydrocarbons.

If there is hydrocarbon vapor present in the beam, then the energy from the lamp reaching the detector in the two half-cycles, instead of being described by equations (6) and (7) will be modified to:

$$E_{L1} = A_L W(\lambda_r T_L) \Delta\lambda_r \quad (16)$$

$$E_{L2} = 0.5 A_L \left[W(\lambda_r T_L) \Delta\lambda_r + (1-a)W(\lambda_s T_L) \Delta\lambda_s \right] \quad (17)$$

where a = fractional absorption due to hydrocarbon vapors.

$$S_L = 0.5 A_L \left[W(\lambda_r T_L) \Delta\lambda_r - W(\lambda_s T_L) \Delta\lambda_s + a W(\lambda_s T_L) \Delta\lambda_s \right] \quad (18)$$

and from Equation (10):

$$S_L = 0.5 A_L a W(\lambda_s T_L) \Delta\lambda_s \quad (19)$$

We may now define a fictitious "absorption," a_B , which would give a signal equivalent to that caused by the background radiation. Combining equations (15) and (19):

$$a_B = \frac{A_B}{A_L} \frac{W(\lambda_r T_B)}{W(\lambda_s T_L)} \left[\frac{W(\lambda_s T_L)}{W(\lambda_r T_L)} - \frac{W(\lambda_s T_B)}{W(\lambda_r T_B)} \right] \quad (20)$$

A rough estimate of A_L can be obtained by assuming that all 60 watts of its power consumption is expended as black-body radiation by the filament at 3000°K .

The basic report¹⁵ indicates that the fraction of emitted source power brought to the detector via the optics is ~15 per cent or 9 watts.

From Planck's relations:

$$\int_0^\infty W(\lambda, 3000^\circ\text{K}) d\lambda = 460 \text{ watts/cm}^2 \quad (21)$$

$$\therefore A_L \times 460 \text{ watts/cm}^2 = 9 \text{ watts} \quad (22)$$

$$A_L = 0.02 \text{ cm}^2 \quad (23)$$

From tabulated values of Planck's function:

$$\frac{W(\lambda_s, T_L)}{W(\lambda_r, T_L)} = \frac{W(3.4\mu, 3000^\circ\text{K})}{W(3.0\mu, 3000^\circ\text{K})} = 6.8 \times 10^{-1} \quad (24)$$

$$\text{and } W(\lambda_s, T_L) = W(3.4\mu, 3000^\circ\text{K}) = 26.6 \quad (25)$$

Rewriting equation (20), we obtain:

$$\frac{a_B}{A_B} = \frac{1}{0.02} \frac{W(3.0\mu, T_B)}{26.6} \left[0.68 - \frac{W(3.4\mu, T_B)}{W(3.0\mu, T_B)} \right] \quad (26)$$

Figure 12 is a plot, vs. T_B , of $\frac{a_B}{A_B}$, i. e., the apparent absorption per square centimeter of effective $\frac{a_B}{A_B}$ radiating background area "seen" by the detector.

Of course, A_B , cannot be accurately predicted, as it would depend upon the particular constructional details of the instrument and the compartment being monitored. However, as the hydrocarbon levels to be detected may correspond to as little as 1 per cent absorption, it does appear that at high temperatures the thermal background signal may well constitute an appreciable source of error.

The above discussion applies to the instrument configuration as presently constituted. This problem may be almost entirely eliminated, however, by placing the modulator at the lamp, rather than the detector. In this way, if only the lamp radiation is modulated, the thermal background radiation will simply add a constant DC component and not contribute to the instrument output.

3. Conclusions

An instrument based on detection of hydrocarbons by infrared absorption such as the MSA detector, should have adequate sensitivity for detecting JP-6 at the desired levels. Its applicability for usage in high-performance aircraft will be dependent primarily upon the ease with which the thermal effects mentioned above can be compensated for, moderated, or eliminated. As the magnitude of some of these effects will depend, in large part, on parameters which are difficult to predict quantitatively (such as chamber materials, cooling facilities, gas circulation, etc.) we have in these cases attempted simply to point out that problem without making a firm judgment as to whether it can be surmounted. Such judgments would ultimately have to be made on the basis of a complex empirical analysis, which could not be achieved under the limited scope of the present study. However, there appears to be no inherent reason why, with adequate redesign, this technique could not be utilized for monitoring JP-6 in high-performance aircraft.

D. Aluminum Oxide Hygrometer

The laboratory experiments described above have shown that the leakage of hydrogen into a hot compartment ($> 1300^{\circ}\text{F}$) containing air, will result in an immediate oxidation reaction with the formation of water. Thus, it is believed that, in the hot compartments of advanced type aircraft, it would be highly unlikely that there would be sufficient hydrogen available for detection. The best means of determining whether hydrogen has leaked into a hot compartment is then by measuring the rise in ambient water vapor concentration.

Indeed, since partial oxidation occurs with JP-6 fuel at temperatures greater than 700°F , it was believed that a suitable water vapor detector also could detect this fuel by measuring the rise in ambient water vapor concentration due to this partial oxidation.

Numerous water vapor measuring devices are available. However, the most advanced state-of-the-art technique for determining water vapor employs the aluminum oxide hygrometer.¹⁶ The most reliable analysis of water vapor calls for a sensitive, accurate, fast-responding sensor capable of direct environmental measurements. These requirements are met by the aluminum oxide element.

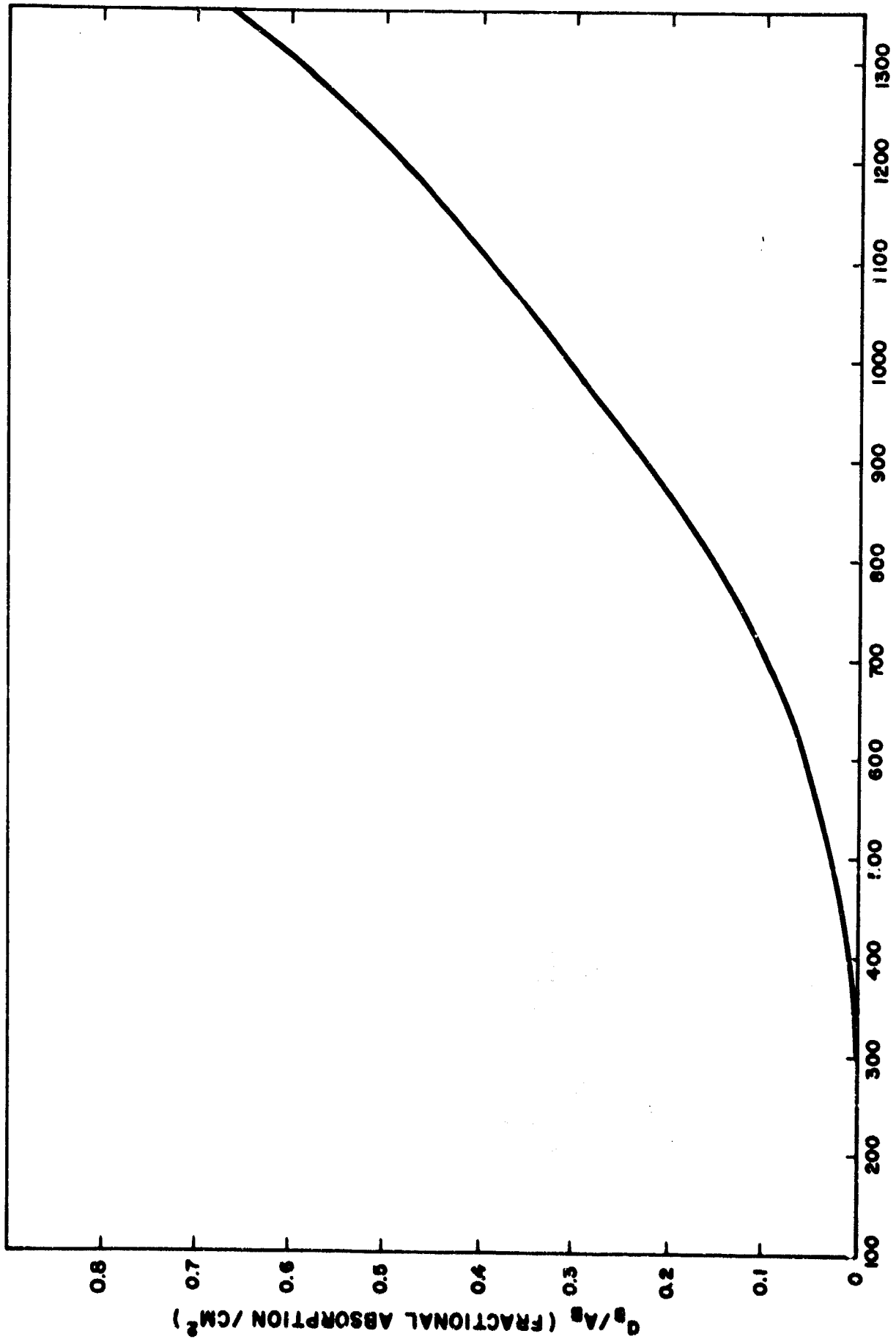

Figure 12. Apparent "Absorption" Due to Thermal Background (Per cm² Effective Radiation Area)

T_B = BACKGROUND TEMPERATURE (°F)

This sensor consists of an aluminum strip which is anodized to provide a porous aluminum oxide layer. A very thin coating of gold is evaporated over this structure. The aluminum base and the gold layer form two electrodes of what is essentially an aluminum oxide capacitor.

Water vapor is rapidly transported through the gold layer and equilibrates on the pore walls in a manner functionally related to the vapor pressure of water in the atmosphere surrounding the sensor. The number of water molecules absorbed on the oxide structure determines the conductivity of the pore wall. Each value of pore wall resistance provides a distinct value of electrical impedance which in turn is a direct measure of the water vapor pressure.

This sensor can measure water vapor concentrations from 20,000 micrograms of H_2O per liter to $0.001 \mu g H_2O/liter$. Extremely rapid response is available from the humidity element. A 63 per cent change is obtained over the entire dynamic range in a few seconds. Presently, this sensor is operable over a temperature range of $-166^\circ F$ to $200^\circ F$.

The excellent characteristics of this sensor warranted an investigation as to its ability to detect hydrogen and hydrocarbon vapors by detecting the water formed on combustion of these fuels.

1. Detection of JP-6 Fuel with the Al_2O_3 Humidity Sensor

A simple, but effective, test apparatus was used to determine the applicability of the Al_2O_3 sensor to detect JP-6. This apparatus consisted of a $3/8$ " quartz tube encompassed by a resistive wire-wound oven. In series with this tube was a small chamber containing the humidity sensor. JP-6 vapors were passed through this quartz tube "hot zone." Any water formed from the oxidation of this fuel could be detected with the humidity sensor.

The hot zone temperature was varied from room temperature to $1200^\circ F$. Since the presently available humidity sensor cannot withstand temperatures in excess of $200^\circ F$, the sensor itself was maintained at room temperature. The results of these experiments are shown in Figure 13. These results are in complete agreement with the results obtained with the kryptonate sensors. No change in ambient water vapor concentration was observed until a temperature of $700^\circ F$ was achieved in the hot zone. At this temperature partial oxidation of the fuel occurs with a subsequent increase in water vapor concentration. The signal then remains relatively constant until a temperature of $1200^\circ F$ is reached at which point the water vapor concentration again increases. These changes in water vapor concentration correspond precisely to the changes in kryptonate sensor signal. Thus, not only must the fuel be cracking to more reactive constituents, as evidenced by the increase in kryptonate

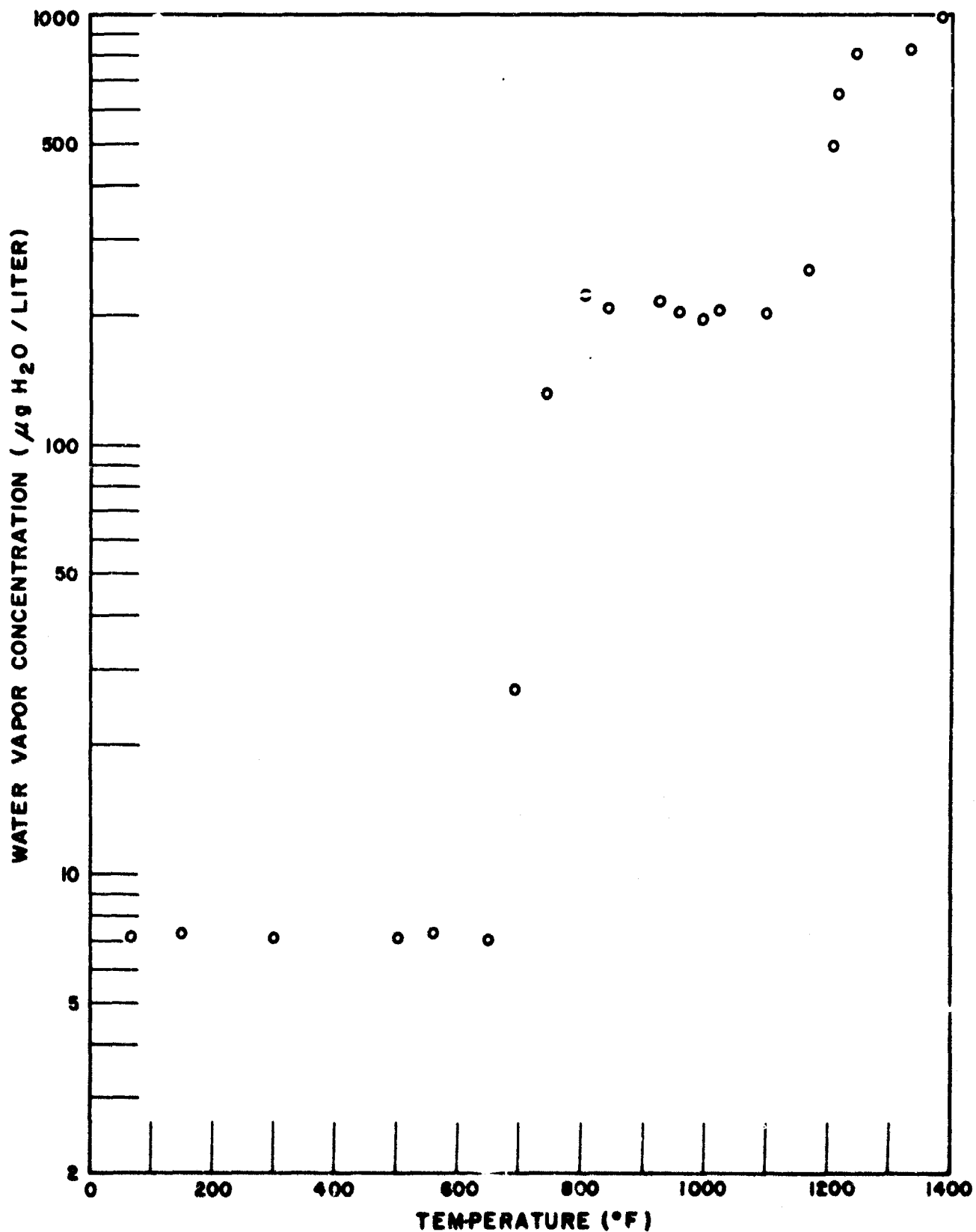

Figure 13. Response of Al_2O_3 Hygrometer to H_2O Vapor Formed on Partial Combustion of JP-6 Fuel

sensitivity, but complete oxidation resulting in the formation of water must also be occurring. Although the amount of water vapor formed at temperatures in excess of 700° F is relatively small (at least in comparison to the amount of water formed on combustion of 1 per cent hydrogen, (See Section D-1), it is sufficient to enable detection of the JP-6 fuel.

There are three important factors to consider in the application of this hygrometer as a possible hydrocarbon detector. These are:

1. The ability of the sensor to detect the water formed on combustion of the fuel above ambient water vapor concentrations.
2. The ability of the sensor to detect the fuel over the entire range of expected environmental temperatures.
3. The ability of sensor to operate over the entire range of expected environmental temperatures.

a. Effect of Ambient Water

Assuming the humidity sensors were capable of operating at temperatures up to 1200° F (See Section b), the ideal operating mode would be to simply place the sensor alone in the hot compartment of a advanced type aircraft and monitor the water vapor concentration. Any increase in water vapor concentration above ambient levels would indicate a leakage of fuel into the hot compartment. It is apparent that under these conditions, the humidity sensor would be capable of detecting the fuel only if the compartment temperature was in excess of 700° F where partial oxidation of the fuel can occur. Under these conditions, a concentration of fuel 0.58 per cent by weight of fuel will oxidize to form approximately 200 micrograms of H₂O per liter of air (assuming the degree of oxidation is similar to that incurred in the laboratory experiments). This amount of water formed is considerably less than normal ambient water concentrations at sea level. However, at the altitudes where temperature in excess of 800° F will be attained, the ambient water vapor concentration is so low that essentially any water detected is due solely to the leakage of the combustible fuel.

In Figure 14 is shown the variation of water vapor concentration with altitude as measured with the aluminum oxide humidity element. The descent curve indicates the true water vapor concentration. (The ascent curve shows higher levels due to the humidity element detecting the water vapor from the wake of the carrier balloon as it rises.) It can be seen that at altitudes above 50,000 feet the atmospheric water vapor concentration is only of the order of 3 micrograms of H₂O per liter of air. The water formed on the partial oxidation of 0.58 per cent of JP-6 fuel is of the order of 200 µgH₂O/liter at 800° F and of the order of 800 µgH₂O/liter at temperatures in excess of 1200° F so that atmospheric water vapor

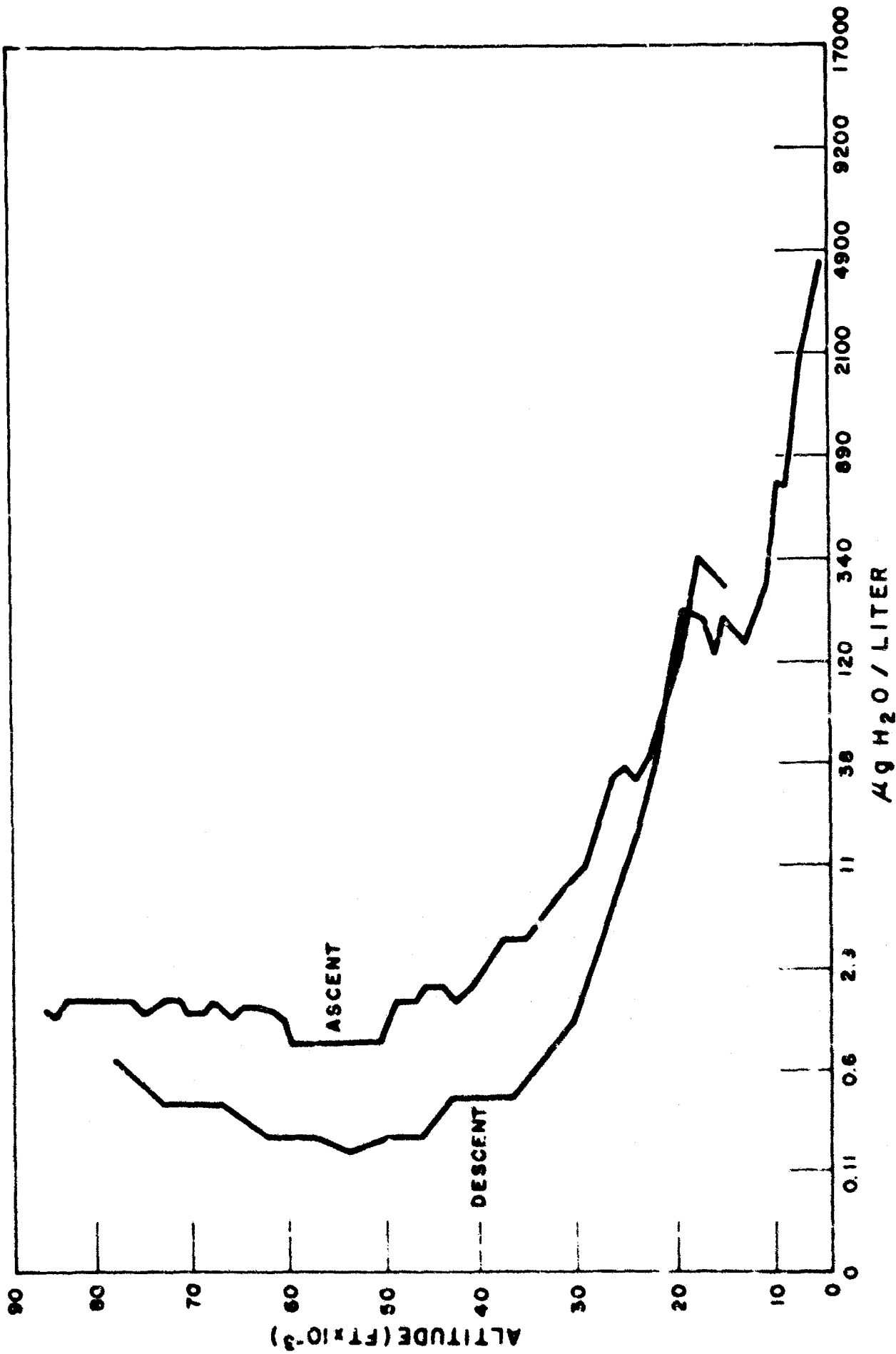

Figure 14. Water Vapor Concentration VS. Altitude

would not be a serious interference.

Thus for high altitude (>30,000 ft.) operation and at compartment temperatures in excess of 700°F, a high temperature humidity element could be satisfactorily employed as a JP-6 detector. At the lower altitudes and lower compartment temperatures, other operating modes and configurations for the sensor must be employed. These conditions are discussed below.

b. Detection of JP-6 with the Humidity Sensor at Temperatures <700°F

From the experiments conducted, it was shown that JP-6 vapors are not significantly combusted to water vapor at temperatures less than 700°F. Thus, in order to utilize the humidity sensor for JP-6 detection, an indirect means of forming water from the fuel must be employed. In addition, elimination of the high ambient water vapor concentrations at the low altitudes must be considered.

The system shown in Figure 15, could be satisfactorily employed to determine JP-6 vapors at all the ambient conditions. The requirements for the elimination of ambient water and for the oxidation of the fuel necessitate a flow system to be employed with the sensor. Although this is somewhat of a disadvantage, if the sensor can withstand the high environmental temperatures, no other electronic components would be involved. Such a system could operate at all the ambient conditions directly in the hot compartment.

At temperatures below 800°F, ambient water vapor can be eliminated by employing a drying tube with a suitable desiccant such as silica gel. Although the capacity of such desiccants is limited, its efficiency to remove water vapor would not be significantly altered during the mission profile of the flight. The JP-6 fuel can then be catalytically oxidized by passing them over a platinum surface. The amount of water formed on combustion of the fuel on the platinum surface depends on the temperature of the surface. By operating this surface above the expected environmental temperatures, environmental temperature fluctuations would be eliminated and the amount of water formed will be constant at any constant JP-6 concentration.

The system can be designed to detect JP-6 vapors at all the ambient conditions by utilizing two humidity sensors. At all temperatures below 700°F, one humidity sensor and associated flow system is used to detect the JP-6 vapors. The compartment atmosphere is passed through the dryer, removing ambient water vapor but allowing the hydrocarbon vapors to pass. The vapors are then catalytically oxidized by the finely divided platinum forming water vapor. The water formed is detected with the humidity sensor and evaluated in terms of JP-6 concentration. This system

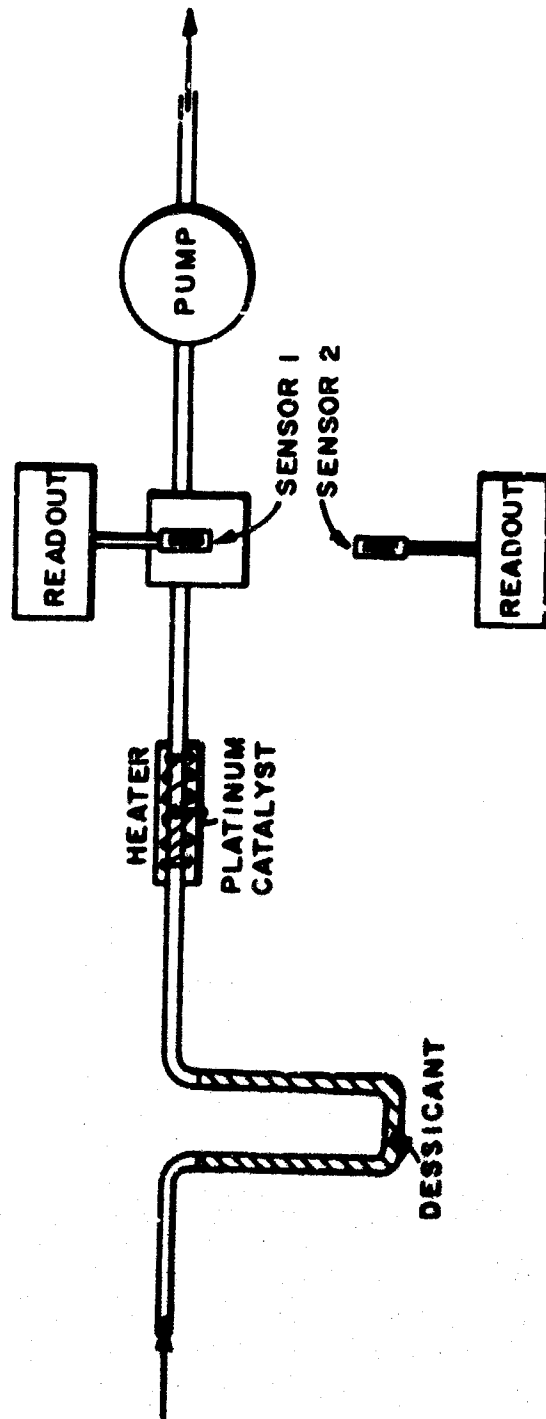

Figure 15. A O_3 Humidity Element System for Detection of JP-6

could not be used above 700°F since the water formed by the self-generating combustion of JP-6 would be absorbed by the desiccant.

At temperatures above 700°F , sensor #2 is used. Here the water formed by the reaction of the hydrocarbon vapors and the oxygen on the walls of the compartment is directly measured with the humidity sensor. As discussed above, at the expected altitudes, ambient water vapor is not expected to be an interference.

c. Ability of Humidity Sensor to Operate at Elevated Temperatures

The current maximum temperature at which the humidity sensor is capable of operating is 200°F . Thus, in order to detect the combustible vapors at high temperatures, the sensor must be cooled or placed outside of the hot compartment into a cool compartment. These requirements result in the same disadvantages and limitations discussed previously for any sensor not capable of operating at high temperatures.

Theoretically, the maximum operating temperature of the Al_2O_3 humidity sensor is close to the melting point of aluminum (1220°F). However, in practice, the maximum temperature at which the sensor used in these studies can operate is limited by the thermal degradation of an organic polymer used in insulating the electrical leads from the gold and aluminum layers. Recent developments have shown that silicon monoxide can be used as an insulator in place of the organic and that the insulating layer itself may be eliminated; however, considerable effort is still required in this area before definite conclusions can be drawn.

Despite the present temperature limitations, the advantages of simplicity, compactness, sensitivity, and response of this Al_2O_3 humidity element warrant further investigation of the element for JP-6 detection but will probably require additional sensor development.

2. Detection of Hydrogen with the Al_2O_3 Sensor

The present temperature limitation of the humidity sensor is even more severe when one considers utilizing this sensor for detecting hydrogen at the expected ambients. Even if the theoretical maximum temperature of 1220°F were attained for this sensor, it would still not be sufficient to enable the sensor to operate at the compartment temperatures expected in a hydrogen powered aircraft. A completely new sensor using a high temperature metal as the base metal (such as tantalum) would have to be developed. Although such an element might be developed, considerable time and effort would be required.

Nevertheless, since most of the present state-of-the-art techniques would require cooling of the sensor unit, this handicap is no more serious than for the other techniques. Indeed, since the experiments conducted

indicate that hydrogen does not exist in the presence of air at temperatures greater than 1000°F, hydrogen must be detected by measuring the water formed on combustion. An investigation was thus conducted to determine if the Al₂O₃ sensor could be used to detect hydrogen with the assumption that the sensor could be cooled.

a. Experimental Evaluation of Al₂O₃ Sensor for Hydrogen

The same apparatus used in evaluating the humidity element for the detection of JP-6 (see Section D-1) was used. Hydrogen at various concentrations was passed through the quartz tube hot zone as the temperature of the hot zone was gradually increased. The humidity sensor was maintained at room temperature during the course of the experiments. The amount of water formed was determined with the hygrometer by measuring its change in impedance. The results of these experiments are shown in Figure 16.

No increase in water vapor concentration was detected until a temperature of 1100°F was attained in the hot zone. The water vapor concentration increased rapidly between 1100°F and 1350°F. At temperatures greater than 1350°F, no further increase in water vapor concentration was observed. At temperatures greater than 1350°F, the results obtained indicate that complete combustion of the hydrogen to water has occurred. Table 3 below shows the theoretical amounts of water formed on 100 per cent combustion of various concentrations of hydrogen and the experimental values shown in Figure 16, for temperatures greater than 1350°F.

Table III

Theoretical and Experimental Amounts of H₂O

Formed on Combustion of Hydrogen

Hydrogen Concentration (% by Volume)	Theoretical H ₂ O Formed (µg/l)	Experimental H ₂ O Formed (µg/l)
0.1	740	710
0.5	3700	3600
1.0	7400	7500

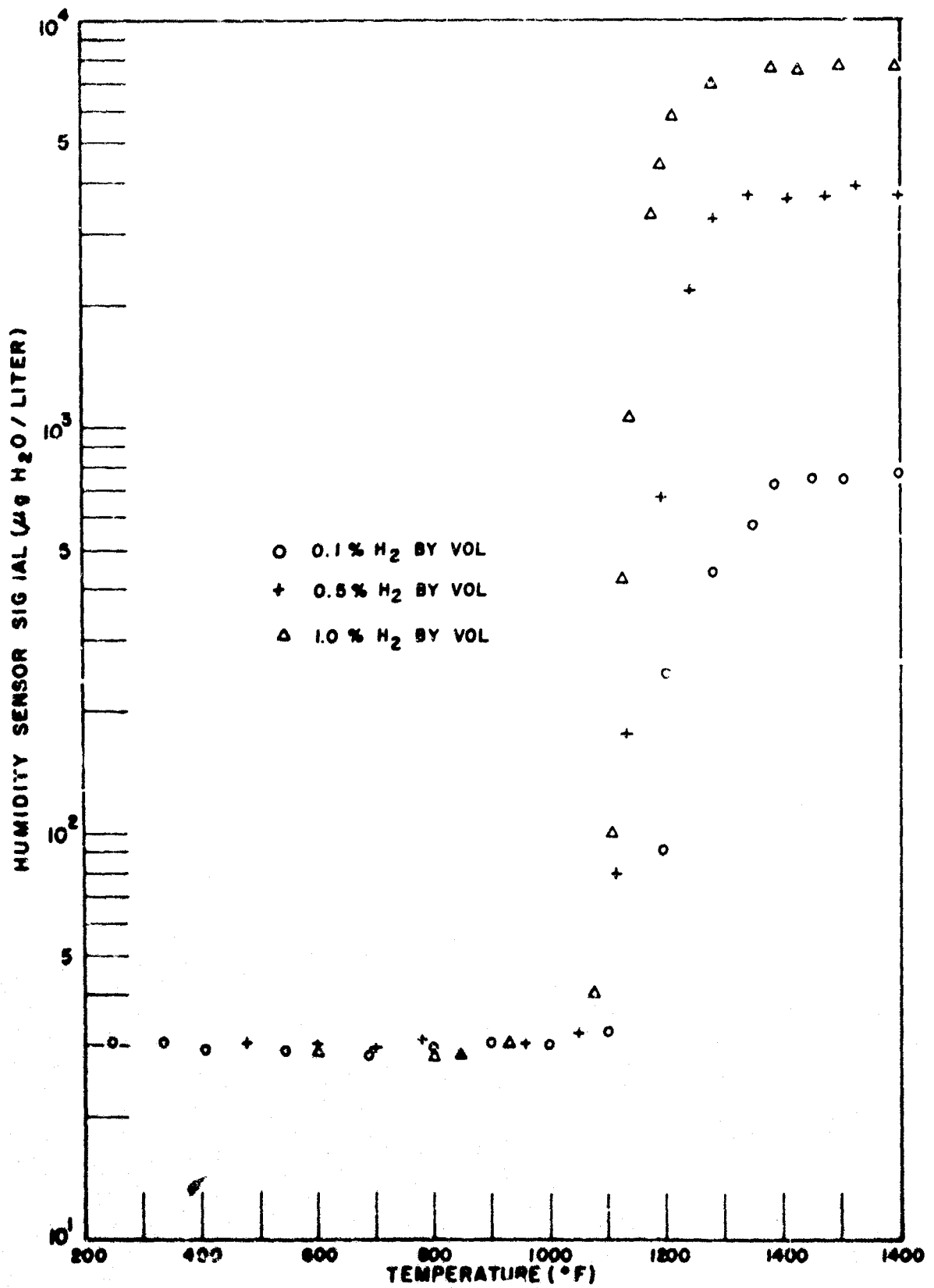

Figure 16. Response of Al₂O₃ to H₂ Vapor Formed on Combustion of Hydrogen

Figure 17 compares the results obtained with the kryptonate sensor and the humidity element for a 1 per cent hydrogen concentration as the environmental temperature is varied from room temperature to 1800° F. The results are in complete agreement. The kryptonate sensor signal decreases at 1100° F indicating that hydrogen is being destroyed, and the humidity sensor increases indicating that water is being formed at the same temperature.

b. Discussion of Results

Basically, the same limitations and capabilities of this sensor discussed for JP-6 hold for hydrogen. It is apparent that since hydrogen does not combust below 1100° F (in the absence of a hot ignition source) then the hydrogen must be detected by forcing combustion on a catalytic surface. Thus the same technique discussed for JP-6 can be employed for hydrogen, i. e., using a flow system and a cell of platinum black. With such a system the humidity element could be used to detect hydrogen at all the required operational conditions.

Although the necessity of a drying tube would be required at sea level conditions, the high quantities of water formed on the complete combustion of hydrogen would allow the utilization of a rather inefficient drying agent. Thus ambient water, especially at altitudes greater than 10,000 feet, would not be a problem.

E. Other Techniques

In addition to the techniques discussed above, two other techniques, viz., catalytic combustion and photoionization, will be discussed. Insufficient time and funds were available for a thorough experimental evaluation of these techniques, however, certain conclusions can be reached concerning the capabilities and limitations of these techniques for the detection of hydrogen and JP-6 fuel aboard advanced aircraft. These conclusions are based mainly on the facts which are contained in the literature as well as on minor experimentation conducted.

1. Catalytic Combustion

This technique has been successfully employed for many years for the detection of various combustible gases. It consists of an exothermic oxidation or reduction of the vapors over a catalyst resulting in a rise in temperature of the catalyst and substrate. The rise in heat content is measured as a function of the gas concentration.

Normally, two thermistors are utilized in a bridge circuit. One thermistor is coated with a catalyst (usually platinum black), the other is left uncoated. The signal is obtained from the imbalance of the two thermistors when combustion occurs at the catalyst coated thermistor.

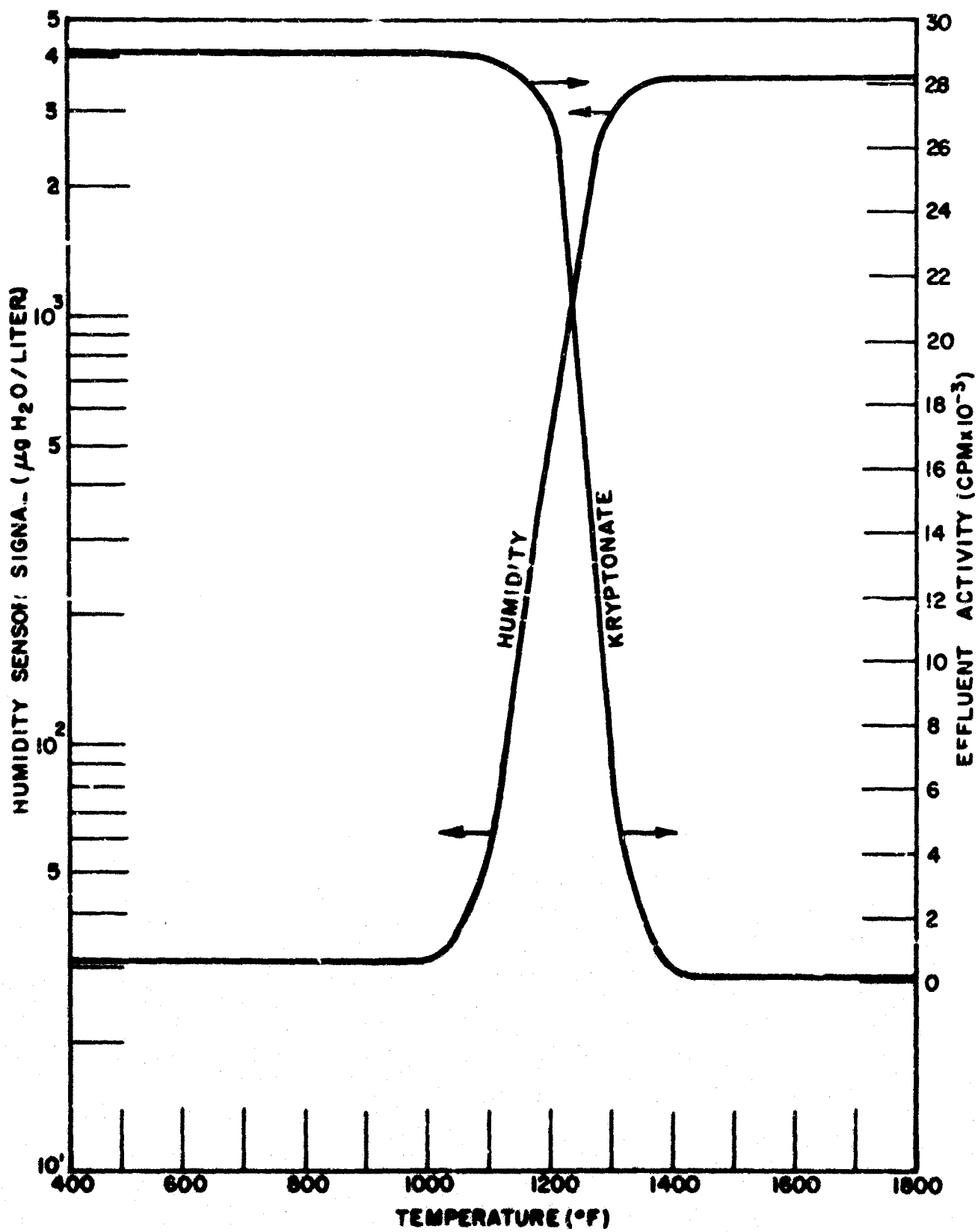

Figure 17. Comparison of Response of Humidity Sensor and Kryptonate Sensor to 0.5% H_2

In the absence of the combustible vapor, the thermistors should be in balance since both thermistors are at the same environmental temperature.

In principle, this technique would be an excellent method to utilize for combustible vapor detection on advanced aircrafts. The thermistor system would require no plumbing, windows, motor, or other associated components. The thermistor imbalance is simply an electrical signal which can be fed directly to a readout meter.

The detection of hydrogen with this system has been well established. Concentrations of hydrogen down to 0.1 per cent can be measured at normal ambient conditions. The ability of the technique to detect JP-6 vapors was not definitely established. Therefore, a very brief experimental effort was conducted to determine if this technique could indeed detect JP-6 vapors.

JP-6 vapors at a concentration of approximately 0.1 per cent by weight were passed over two balanced thermistors, one of which was coated with platinum black. An imbalance of the bridge circuit of approximately .04 millivolts was obtained indicating that the coated thermistor did indeed increase in temperature due to the catalytic combustion of the JP-6 vapors on its surface. Although these experiments were brief, sufficient care was taken to definitely establish that the technique was capable of detecting JP-6 at concentrations of approximately 0.1 per cent by weight at ambient pressure.

When thermistors are utilized for this type of gas analysis, they are operated at elevated temperatures (above 300° F). This high temperature causes them to operate in a region where a decrease in thermistor resistance is obtained with increasing temperature. The maximum temperature at which these thermistors presently can operate is approximately 900° F. These thermistors should be capable of detecting both hydrogen and JP-6 fuel for at least Mach 4 type aircraft or equivalent compartment temperatures. For higher compartment temperatures, the thermistors must be cooled to at least this maximum operating temperature.

Without direct experimental evidence, it is difficult to conclude whether these thermistors can reliably detect the vapors of interest while the environmental temperature is varying from -60° F to 900° F. Although the thermistors should be in balance in the absence of the combustible vapors, a certain amount of imbalance would occur due to the differences in heat transfer characteristics between the coated thermistor and the uncoated thermistor. The degree of imbalance due to the temperature fluctuations and pressure changes occurring within the environmental compartment can be determined best by experimentation. It is believed that these effects will be small; however, they may be sufficient, especially at low vapor concentrations, to require an electrical feedback system to maintain the thermistors in balance.

A possible drawback of the technique for its present application is its relatively low sensitivity. The method is dependent upon the existence of a significant temperature differential between the two thermistors when combustion occurs. Typically, the lower limit of sensitivity for combustible vapors with this technique is approximately 0.1 per cent by volume. The brief experiments conducted using this technique for JP-6 indicate that it should be capable of detecting .01 per cent JP-6 by weight. Although this sensitivity is sufficient at sea level altitudes, lower equivalent concentrations expected at the higher altitudes could not be determined without sophisticated and complex instrumentation. Thus it appears that the sensitivity requirements at high altitudes are beyond the capability of current instrumentation.

The operating life of these thermistors may be limited severely by catalytic poisoning. Minute amounts of contaminant gases are known to poison platinum black catalysts thus destroying their ability to catalyze the hydrocarbon-oxygen reaction. Although the poisoning mechanism of catalysts is not well understood, it is known that such gases as hydrogen sulfide will render a catalyst useless. Since the contemplated hydrocarbon fuel contains small amounts of sulfur, the formation of hydrogen sulfide or organic sulfides is highly likely. These gases, or numerous other trace constituents emanating from the fuel or the materials of construction of the aircraft, may severely limit the operating life of the thermistors.

Because of this poisoning, it would be extremely difficult to design an instrument based on this technique that would be fail-safe. Partial poisoning would not only decrease the life of these sensors but would also cause a decrease in sensitivity which would not be detected unless the system were recalibrated at frequent intervals. This partial or total poisoning would make it extremely difficult to ascertain when thermistor replacement would be required.

Finally, the operation of a catalytic surface at elevated temperatures constitutes an explosion hazard. Unlike the kryptonate sensors, these catalytic surfaces initiate the hydrocarbon-oxygen reaction and thus can serve as an ignition source. (The kryptonate sensors are deliberately coated with a molecular barrier material to prevent catalytic combustion.) Thus, a considerable design effort in rendering such a system explosion proof would be required to eliminate this possibility.

2. Photoionization

The final technique which will be discussed is that of photoionization. This technique, based upon photoionization of the detected gas, requires the generation of light in the ultraviolet region. Provided that the light used has an energy, $h\nu$, greater than the ionization potential, IP, of the gaseous species to be detected, absorption of a photon will release a photoelectron, thus forming an ion pair. This absorption is caused to

take place in an ion detector chamber containing the gas to be analyzed. The charged species formed are collected by electrodes, the collection current being a function of the degree of ionization and the concentration of ionizable species.

For a particular species and wave length of incident light, the ionization efficiency is constant and the observed current is determined by the concentration of the gaseous species.

Figure 18 is a simplified representation of a possible instrument based on this technique. The light source is a H₂ discharge lamp, emitting Lyman alpha radiation (1216 Å) with a LiF window (LiF is transparent down to about 1200 Å). The light from this lamp passes through the sample space as shown. Ions formed by photoionization along this part are collected by the parallel plate electrodes, the collector current being proportional to the rate of ionization in the volume being monitored. To prevent spurious currents due to photoelectrons emitted by the action of the light upon the collector electrodes, the beam is collimated as shown. For the purpose of discussion, let us assume the following parameters for this device:

Lamp intensity (at 1216Å)	
entering sample space	$\sim 10^{15}$ photons/sec
Electrode length	~ 5 cm
Electrode separation	~ 1 cm

An examination of the ionization potentials of various molecules¹⁸ shows that 1216 Å (10.2 eV) is sufficient to ionize saturated hydrocarbon molecules higher than pentane, which undoubtedly encompasses most of the constituents of JP-6 fuel. On the other hand, this is insufficient to ionize either H₂ or the normal atmospheric constituents N₂, O₂, H₂O, CO, and CO₂.

As mentioned above, the collection current will be a function of the concentration of the ionizable species. This may be expressed mathematically:

$$\frac{dg}{dt} = I \sigma C l \quad (27)$$

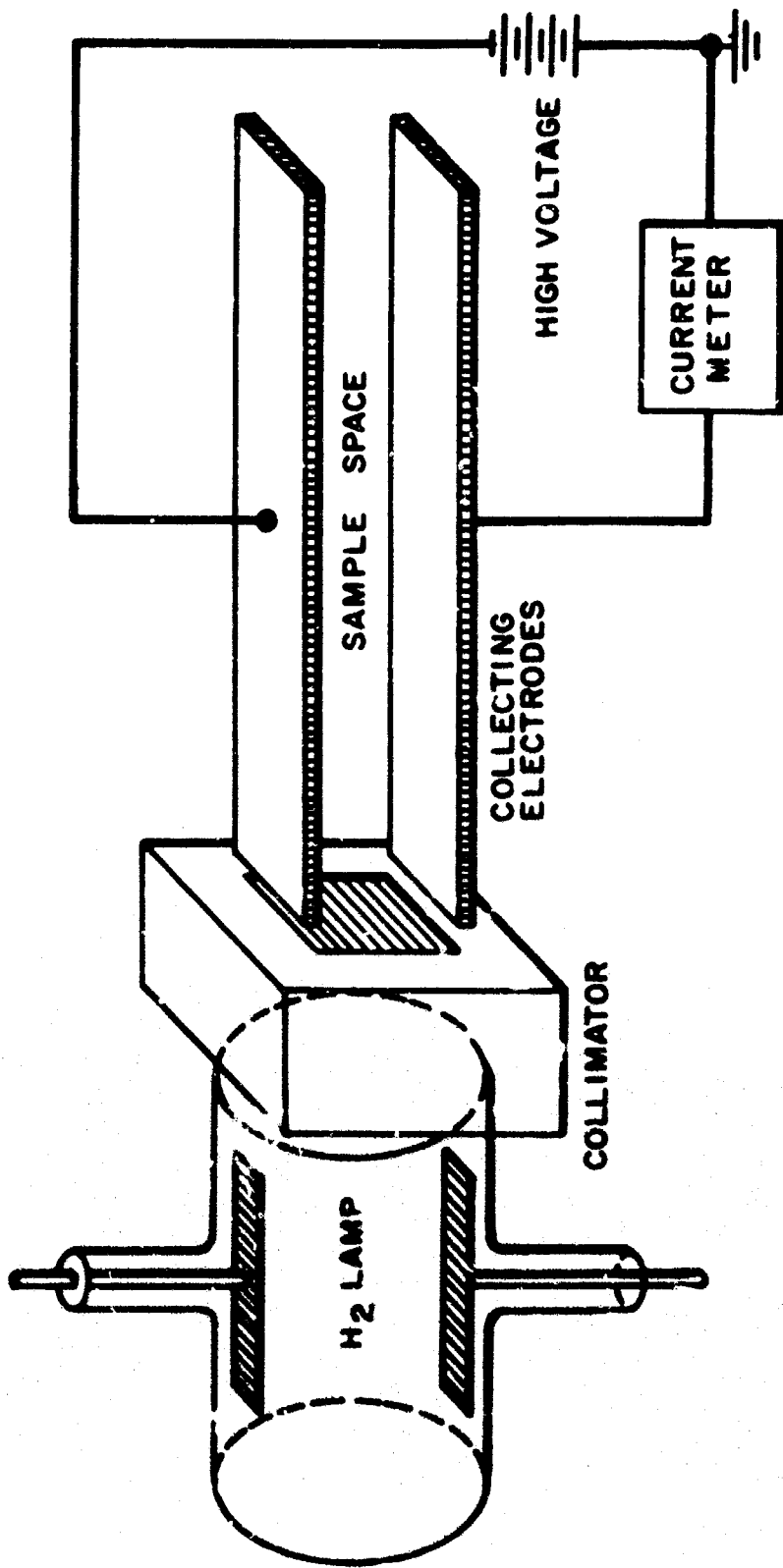

Figure 18. Photoionization Detector

where $\frac{dq}{dt}$ = rate of ionization (ion pairs/sec)

I = beam intensity (photons/sec)

σ = cross-section for ionization ($\text{cm}^2/\text{molecule}$)

C = concentration of ionizable species ($\text{molecules}/\text{cm}^3$)

l = length of path

Substituting the values previously assumed

$$\frac{dq}{dt} = 5 \times 10^{15} \sigma C \quad (28)$$

As the minimum detection level desired is 0.15 per cent (by volume) at 0.01 atmosphere, and 1200° F, this corresponds to $C \approx 1.2 \times 10^{14}$ molecules/ cm^3

$$\therefore \frac{dq}{dt}_{\text{min}} \approx 6 \times 10^{29} \sigma \quad (29)$$

Because of the complex composition of JP-6 fuel, an exact value for σ cannot be calculated. However, a reasonable lower estimate, based on other species, is $\sigma = 4 \times 10^{-18} \text{cm}^2/\text{molecule}$.

$$\therefore \frac{dq}{dt}_{\text{min}} \approx 2.4 \times 10^{12} \text{ ion pairs/sec} \quad (30)$$

For 100 per cent collection efficiency, this corresponds to a collection current of about 4×10^{-7} amperes which is certainly readily measurable by standard instrumentation.

As the ambient pressure may vary from 1 atmosphere (760 torr) to .01 atmosphere (7.6 torr), one must ensure that the collection electrode separation and the applied potential will not present a problem due to voltage breakdown and yet be adequate to provide sufficient collection efficiency. By use of the usual Paschen relation¹⁹ it can be shown that, with 1 cm between the plates, an applied potential of the order of 800 volts should not cause breakdown over the anticipated pressure range. While this potential may not yield 100 per cent collection efficiency at higher pressures, it should be remembered that, at high pressures, much more ionization will be occurring than that calculated above.

The above has been a simplified treatment of the feasibility of the photoionization technique. It is recognized that several possible problem areas remain. Among these are the effect of high ambient temperatures on the components, the attenuation of the beam by oxygen absorption, difficulties in constructing a stable lamp, etc. In addition, of course, the phenomenon of thermal degradation of JP-6 vapor may, as with the other techniques, present problems in interpreting the data. It is probable that, if the vapor is not completely oxidized to CO_2 , the product molecules will still be ionizable by the selected wavelength.

SECTION III

CONCLUSIONS

1. The kryptonate technique can be upgraded satisfactorily to detect hydrocarbon vapors, specifically, JP-6 vapors, at the required temperatures and pressures. JP-6 fuel can be detected aboard advanced aircraft with a Mach 3 capacity utilizing the standard aluminum oxide-platinum dioxide kryptonate sensor. For aircraft with a Mach 4 or higher capability, kryptonated palladium oxide appears to be the optimum sensor material. In the absence of radiation detectors capable of withstanding the high environmental temperatures, the response times would be limited by the time required for krypton-85 transportation from the cell to the detector. Such response times would be typically of the order of 5 to 7 seconds. When high temperature radiation detectors do become available, this response time can be reduced to 1 to 2 seconds.

2. Kryptonated copper oxide can be used to detect hydrogen vapors at the specified environmental conditions. However, the results obtained during this work indicate that the existence of hydrogen at these environmental conditions would be highly unlikely.

3. An instrument based on the detection of hydrocarbons by infrared absorption should have adequate sensitivity for detecting JP-6 at the desired levels. There appears to be no inherent reasons why this technique could not be satisfactorily developed into an instrument which would be capable of detecting JP-6 vapors at all the contemplated environmental conditions and requirements. However, temperature as well as pressure compensation would be required.

4. The aluminum-oxide hygrometer technique can be used satisfactorily to detect hydrogen and hydrocarbons by measuring the water formed on catalytic combustion. At the present time, the maximum operating temperature of this sensor is 200° F. Although it is believed the operating temperature can be increased to approximately 650° F, higher temperatures may yet be available but have not been investigated in view of the improvements believed to be necessary for operation up to 650° F.

5. The catalytic combustion technique appears to have limited applicability for the detection of hydrogen and hydrocarbons aboard advanced type aircraft. Its main disadvantages for the intended usage is its relatively poor sensitivity, instability, and, most important, the fact that it is readily poisoned by numerous trace gas constituents.

The photoionization technique appears to be a most promising method for the detection of hydrocarbons aboard advanced aircraft. A brief evaluation of this technique indicates that no major obstacles should be encountered in designing a workable system based on this technique.

However, since this is an advanced concept, a considerable amount of experimental as well as further investigative work would be required before definite conclusions as to its ability to detect hydrocarbons under the specified environmental conditions could be drawn.

REFERENCES

1. D. Chleck and O. Cucchiara, Int. J. Appl. Rad. Isotopes 14, 581 (1963).
2. D. Chleck and R. Maehl, Int. J. Appl. Rad. Isotopes 14, 593 (1963).
3. D. Chleck et al, First Annual Rept. U. S. A. E. C. Contract AT (30-1)-2757, NYO 9720, TID-4500 (16th Ed.) 1962.
4. D. Chleck, R. Maehl and O. Cucchiara, U. S. A. E. C. Contract AT (30-1)-2757, NYO 2757-2, TID-4500 (1962).
5. D. Chleck, R. Maehl and O. Cucchiara, U. S. A. E. C. Contract AT (30-1)-2757, NYO 2757-3, TID-4500 (1963).
6. D. Chleck, R. Maehl and O. Cucchiara, U. S. A. E. C. Contract AT (30-1)-2757, NYO-2757-5, TID-4500 (1964).
7. D. Chleck, O. Cucchiara and T. Donaghue, Detection Techniques for Hazardous Vapors of Elemental Propellants, Contract AF 33(657)-8916, ASD-TR-63-294 (1963).
8. O. Cucchiara, T. Donaghue and D. Chleck, Detection of Hydrogen Aboard Aerospace Flight Vehicles. Contract AF 33(657)-8916, APL-TR-64-51 (1964).
9. O. Cucchiara, R. Rex and T. Donaghue, The Development of an Instrument for the Detection of Hazardous Vapors. Contract AF 33(615)-1473, AFAPL-TR-65-50 (1965).
10. J. M. H. Fortuin, Low Constant Vapour Concentrations Obtained by a Dynamic Method Based on Diffusion, Analytica Chimica Acta, Vol. 15, 521-533 (1956).
11. Military Specification, Jet Fuel, Grade JP-6 MIL-J-25656B (U. S. A. F.) (1961).
12. A. C. Billetdeaux, R. W. Lawrence, and R. S. Freitino, An Explosive Vapor Detector for Rocket Powered Aircraft. Contract AF 33(600)-40409, ASD-TDR-62-531, p. 1 (1962).
13. Ibid. pp. 6-9.
14. Ibid. p. 15.
15. Ibid. p. 44.

16. D. Chleck and F. Brousaides. "A Partial Evaluation of the Performance of an Aluminum Oxide Hygrometer Element," Humidity Moisture Vol. 1, A. Wexler, Editor-in-Chief, Rheinhold Publishing Co., New York.
17. Combustion Analysis, Technical Bulletin V1142A, Victory Engineering Corp., Springfield, New Jersey.
18. K. Watanabe, et al, J. Quant. Spectrosc. Radiat. Transfer, 2, 369 (1960).
19. G. Harnwell. Principles of Electricity and Electromagnetism. New York: McGraw-Hill Book Company, Inc., p. 275 (1949).

Unclassified

Security Classification

DOCUMENT CONTROL DATA - R&D

(Security classification of title, body of abstract and indexing annotation must be entered when the overall report is classified)

1. ORIGINATING ACTIVITY <i>(Corporate author)</i> PARAMETRICS, Inc., Waltham, Massachusetts		2a. REPORT SECURITY CLASSIFICATION Unclassified
		2b. GROUP
3. REPORT TITLE INVESTIGATION OF HAZARDOUS VAPOR DETECTION FOR ADVANCED FLIGHT VEHICLES		
4. DESCRIPTIVE NOTES <i>(Type of report and inclusive dates)</i> 15 March 1965 through 15 March 1966 Final Report		
5. AUTHOR(S) <i>(Last name, first name, initial)</i> Cucchiara, O., Seiden, L., Donaghue, T.		
6. REPORT DATE 1966	7a. TOTAL NO. OF PAGES 72	7b. NO. OF REFS 19
8a. CONTRACT OR GRANT NO. AF33(615)-2477	9a. ORIGINATOR'S REPORT NUMBER(S) N/A	
b. PROJECT NO. 6075		
c. TASK No. 607508	9b. OTHER REPORT NO(S) <i>(Any other numbers that may be assigned this report)</i> AFAPL-TR-66-71	
d.		
10. AVAILABILITY/LIMITATION NOTICES Qualified requesters may obtain copies of this report from DDC. Foreign announcement and dissemination of this report by DDC is not authorized.		
11. SUPPLEMENTARY NOTES	12. SPONSORING MILITARY ACTIVITY Air Force Aero Propulsion Laboratory Research and Technology Division Air Force Systems Command Wright-Patterson Air Force Base, Ohio	
13. ABSTRACT <p>A program was conducted to evaluate techniques for the detection of hydrocarbon vapors and hydrogen aboard advanced aircraft.</p> <p>A radiochemical exchange technique utilizing kryptonates can be employed satisfactorily for detecting hydrocarbon vapors aboard aircraft with a Mach 3 to Mach 6 capability and hydrogen for Mach 7 and higher capability aircraft. However, it was shown that it is highly unlikely that hydrogen will exist in the presence of oxygen at temperatures in excess of 1300° F. Therefore, an aluminum oxide humidity element was investigated as to its ability to detect the water formed by combustion. This element appears suitable assuming that further development of the element can overcome its present maximum temperature limitations.</p> <p>A non-dispersive, open-path, infra-red technique can, in principle, be upgraded to detect hydrocarbon fuels, (not hydrogen or water), under the stipulated environmental conditions; however, a considerable developmental effort would be required.</p> <p>Catalytic combustion is limited in its applicability due to its relatively poor sensitivity, stability, and operating life. A photoionization technique appears most promising but will require a considerable developmental effort.</p>		

Unclassified

Security Classification

14. KEY WORDS	LINK A		LINK B		LINK C	
	ROLE	WT	ROLE	WT	ROLE	WT
Advanced Aircraft Fuels Hydrocarbons Hydrogen Kryptonates Infrared Water Vapor Catalytic Combustion Photoionization						

INSTRUCTIONS

1. **ORIGINATING ACTIVITY:** Enter the name and address of the contractor, subcontractor, grantee, Department of Defense activity or other organization (*corporate author*) issuing the report.

2a. **REPORT SECURITY CLASSIFICATION:** Enter the overall security classification of the report. Indicate whether "Restricted Data" is included. Marking is to be in accordance with appropriate security regulations.

2b. **GROUP:** Automatic downgrading is specified in DoD Directive 5200.10 and Armed Forces Industrial Manual. Enter the group number. Also, when applicable, show that optional markings have been used for Group 3 and Group 4 as authorized.

3. **REPORT TITLE:** Enter the complete report title in all capital letters. Titles in all cases should be unclassified. If a meaningful title cannot be selected without classification, show title classification in all capitals in parenthesis immediately following the title.

4. **DESCRIPTIVE NOTES:** If appropriate, enter the type of report, e.g., interim, progress, summary, annual, or final. Give the inclusive dates when a specific reporting period is covered.

5. **AUTHOR(S):** Enter the name(s) of author(s) as shown on or in the report. Enter last name, first name, middle initial. If military, show rank and branch of service. The name of the principal author is an absolute minimum requirement.

6. **REPORT DATE:** Enter the date of the report as day, month, year, or month, year. If more than one date appears on the report, use date of publication.

7a. **TOTAL NUMBER OF PAGES:** The total page count should follow normal pagination procedures, i.e., enter the number of pages containing information.

7b. **NUMBER OF REFERENCES:** Enter the total number of references cited in the report.

8a. **CONTRACT OR GRANT NUMBER:** If appropriate, enter the applicable number of the contract or grant under which the report was written.

8b, 8c, & 8d. **PROJECT NUMBER:** Enter the appropriate military department identification, such as project number, subproject number, system numbers, task number, etc.

9a. **ORIGINATOR'S REPORT NUMBER(S):** Enter the official report number by which the document will be identified and controlled by the originating activity. This number must be unique to this report.

9b. **OTHER REPORT NUMBER(S):** If the report has been assigned any other report numbers (*either by the originator or by the sponsor*), also enter this number(s).

10. **AVAILABILITY/LIMITATION NOTICES:** Enter any limitations on further dissemination of the report, other than those imposed by security classification, using standard statements such as:

(1) "Qualified requesters may obtain copies of this report from DDC."

(2) "Foreign announcement and dissemination of this report by DDC is not authorized."

(3) "U. S. Government agencies may obtain copies of this report directly from DDC. Other qualified DDC users shall request through _____."

(4) "U. S. military agencies may obtain copies of this report directly from DDC. Other qualified users shall request through _____."

(5) "All distribution of this report is controlled. Qualified DDC users shall request through _____."

If the report has been furnished to the Office of Technical Services, Department of Commerce, for sale to the public, indicate this fact and enter the price, if known.

11. **SUPPLEMENTARY NOTES:** Use for additional explanatory notes.

12. **SPONSORING MILITARY ACTIVITY:** Enter the name of the departmental project office or laboratory sponsoring (*paying for*) the research and development. Include address.

13. **ABSTRACT:** Enter an abstract giving a brief and factual summary of the document indicative of the report, even though it may also appear elsewhere in the body of the technical report. If additional space is required, a continuation sheet shall be attached.

It is highly desirable that the abstract of classified reports be unclassified. Each paragraph of the abstract shall end with an indication of the military security classification of the information in the paragraph, represented as (TS), (S), (C), or (U).

There is no limitation on the length of the abstract. However, the suggested length is from 150 to 225 words.

14. **KEY WORDS:** Key words are technically meaningful terms or short phrases that characterize a report and may be used as index entries for cataloging the report. Key words must be selected so that no security classification is required. Identifiers, such as equipment model designation, trade name, military project code name, geographic location, may be used as key words but will be followed by an indication of technical context. The assignment of links, rules, and weights is optional.