

UNCLASSIFIED

| |
|---|
| |
| |
| |
| AD NUMBER |
| AD489863 |
| NEW LIMITATION CHANGE |
| TO Approved for public release, distribution unlimited |
| FROM Distribution authorized to U.S. Gov't. agencies and their contractors; Administrative/Operational Use; Oct 1965. Other requests shall be referred to Federal Aviation Administration, Attn: SRDS, Washington, DC 20590. |
| AUTHORITY |
| FAA ltr, 31 Mar 1971 |

THIS PAGE IS UNCLASSIFIED

SPDC Report No. RD - 65 - 119

FINAL REPORT

Contract No. FA-WA - 4474

Project No. 114 - 18 - 2D and 3D

489863

LOW COST ILS GLIDE SLOPE AND MARKERS

OCTOBER 1965

D D C
OCT 10 1966
RECEIVED

This Report has been approved for availability within
the U. S. Government.

Prepared for

FEDERAL AVIATION AGENCY
Systems Research & Development Service

By

ITT *Federal*
LABORATORIES
A DIVISION OF INTERNATIONAL TELEPHONE AND TELEGRAPH CORPORATION
500 WASHINGTON AVENUE, NUTLEY 10, NEW JERSEY

Final Report, Contract No. FA-WA-4474

LOW COST ILS GLIDE SLOPE AND MARKERS

October 1965

Project No. 114-18-2D and 3D

(SRDS Report No. RD-65-119)

Prepared by

D. Battersby

W. Casper

F. Iden

G. Reich

"This report has been prepared by ITT Federal Laboratories for the System Research and Development Service, Federal Aviation Agency, under Contract No. FA-WA-4474. The contents of this report reflect the views of the contractor who is responsible for the facts and the accuracy of the data presented herein and do not necessarily reflect the official views or policy of the FAA. This report does not constitute a standard, specification, or regulation".

ITT *Federal*
LABORATORIES
A DIVISION OF INTERNATIONAL TELEPHONE AND TELEGRAPH CORPORATION
500 WASHINGTON AVENUE, NUTLEY 10, NEW JERSEY

ITT FEDERAL LABORATORIES

NUTLEY, NEW JERSEY

LOW COST ILS GLIDE SLOPE AND MARKERS

Authors: D. B. Crosby, W. Casper, F. Iden, G. Reich

Release Date: October 1965

Number of Pages: 38

Illustrations: 160

Tables: 10

References: 1

Final Report

(FA-WA-4474)

ABSTRACT

The Low Cost ILS Glide Slope and Marker development program was initiated to provide an ILS equipment capable of going into commission with only a fraction of the costs previously occurred in conventional procurements and installations. The program results in a solid state glide slope and marker systems of high commercial grade quality packaged in transportable shelters to minimize on-site costs. Improved antenna systems are developed to reduce siting effects on the glide slope and to improve the efficiency of the marker beacon. It is concluded that the objectives of the program have been achieved by providing a highly reliable glide slope and marker system capable of being inexpensively installed and maintained. Recommendations are made to value engineer certain subsystems of the glide slope equipment.

TABLE OF CONTENTS

| | Page Number |
|--|-------------|
| ABSTRACT | iii/iv |
| LIST OF ILLUSTRATIONS | vii |
| LIST OF TABLES | xiii/xiv |
| INTRODUCTION | 1 |
| FUNCTIONAL OPERATION OF THE GLIDE SLOPE SYSTEM | 2 |
| (1) Transmitter Unit | 2 |
| (2) Sideband Generator | 2 |
| (3) Modulation Control Panel | 2 |
| (4) Transmitting Antenna System | 2 |
| (5) Field Detector Antenna System | 5 |
| (6) Field Detector Unit | 5 |
| (7) Monitor Unit | 5 |
| (8) Control Circuits | 6 |
| (9) Tower Unit | 6 |
| (10) Power Supplies | 7 |
| (11) Equipment Shelter | 7 |
| FUNCTIONAL OPERATION OF THE MARKER BEACON | 7 |
| (1) RF Modulator | 8 |
| (2) Tone Generator | 8 |
| (3) Keyer | 8 |
| (4) Monitor | 8 |
| (5) Control Circuits and Metering | 11 |
| (6) Antenna System | 12 |
| GLIDE SLOPE SYSTEM ENGINEERING DATA | 12 |
| (1) Antenna System | 12 |
| (2) Glide Slope Transmitter TU-8X | 13 |
| (3) Transmitter Unit | 15 |
| (4) Modulation Control Unit | 19 |
| (5) Control Unit | 19 |
| (6) Monitor | 20 |

TABLE OF CONTENTS (contd)

| | Page Number |
|---|-------------|
| (7) RF Level Monitor | 20 |
| (8) Audio Subunits | 25 |
| (9) Power Supply | 26 |
| (10) System Data | 26 |
| (11) Glide Slope Tower Unit TU-8X/2 | 26 |
| (12) Glide Slope Field Detector TU-8X/1 | 27 |
| | |
| MARKER BEACON SYSTEM ENGINEERING DATA | 32 |
| | |
| (1) Antenna System | 32 |
| (2) RF and Modulator Unit | 38 |
| (3) Monitor Unit | 43 |
| (4) Keyer Tone Generator Unit | 44 |
| | |
| MARKER BEACON FLIGHT CHECK | 47 |
| | |
| GLIDE SLOPE SYSTEM FLIGHT TESTS | 48 |
| | |
| CONCLUSIONS AND RECOMMENDATIONS | 49/50 |
| | |
| APPENDIX A | A-1 |

LIST OF ILLUSTRATIONS

| Figure | | Page |
|--------|--|------|
| 1 | Glide Slope Diagram | 3 |
| 2 | Marker Beacon Block | 9 |
| 3 | Glide Slope Antenna Bay Voltage Pattern Horizontal Plane . . . | 14 |
| 4 | Glide Slope Exciter Output Frequency vs Temperature | 17 |
| 5 | Glide Slope Exciter Power vs Temperature | 18 |
| 6 | Glide Slope RF Level Indication vs Temperature | 22 |
| 7 | Glide Slope Meter Indication vs RF Level Change | 23 |
| 8 | Glide Slope Monitor Stability vs Temperature | 24 |
| 9 | Glide Slope Field Detector LO vs Temperature | 29 |
| 10 | Glide Slope Hybrid Input Isolation | 30 |
| 11 | Glide Slope IF Output vs LO Power | 31 |
| 12 | Glide Slope IF Output vs Temperature | 33 |
| 13 | Glide Slope IF Output vs Temperature | 34 |
| 14 | Marker Beacon Antenna Cross-Course Voltage Pattern | 36 |
| 15 | Marker Beacon Antenna On-Course Voltage Pattern | 37 |
| 16 | Glide Slope RF-Modulator Frequency vs Temperature | 39 |
| 17 | Glide Slope Modulation vs Temperature | 41 |
| 18 | Glide Slope Marker Power Output vs Temperature | 42 |
| 19 | Glide Slope Tone Frequency vs Temperature | 45 |
| 20 | Glide Slope Keyer Rate vs Temperature | 46 |

APPENDIX A

| | | |
|------|--|------|
| A-1 | Motor-Hysteresis Class "A" Modulator (C2120782) | A-2 |
| A-2 | Center Conductor Assembly (B2157323) | A-3 |
| A-3 | Dipole Soldering Assembly (D2157330) | A-4 |
| A-4 | ILS Glide Slope Dipole (D2157331) | A-5 |
| A-5 | Clamp (C2205169) | A-6 |
| A-6 | Door Inner (D2205170) | A-7 |
| A-7 | Stop (B2205171) | A-8 |
| A-8 | Nameplate (A2205172) | A-9 |
| A-9 | Nameplate (A2205173) | A-10 |
| A-10 | Schematic Diagram, Monitor Marker Beacon (E2205177) . . . | A-11 |
| A-11 | Box, Inner (J2205180) | A-12 |
| A-12 | Angle, Support (D2205181) | A-13 |
| A-13 | Schematic Diagram, Exciter Glide Slope Transmitter (E2205182) | A-14 |
| A-14 | Holder, Rod (B2205183) | A-15 |
| A-15 | Rod (B2205184) | A-16 |

LIST OF ILLUSTRATIONS (contd)

| Figure | | Page |
|--------|---|------|
| A-16 | Angle, Support (D2205185) | A-17 |
| A-17 | Angle, Support (D2205186) | A-18 |
| A-18 | Spacer (B2205187) | A-19 |
| A-19 | Outer Panel (Side) (D2205189) | A-20 |
| A-20 | Outer Panel (Back) (D2205190) | A-21 |
| A-21 | Outer Panel (Front) (D2205191) | A-22 |
| A-22 | Cover, Top (D2205192) | A-23 |
| A-23 | Plate, Bottom (E2205193) | A-24 |
| A-24 | Door, Inner (D2205194) | A-25 |
| A-25 | Cover, Inner (E2205195) | A-26 |
| A-26 | Angle (C2205196) | A-27 |
| A-27 | Support, Angle (C2205202) | A-28 |
| A-28 | Shelf (Power Supply) (D2205197) | A-29 |
| A-29 | Channel (A2205198) | A-30 |
| A-30 | Panel, Meter (Drilling) (D2205199) | A-31 |
| A-31 | Shelf (E2205200) | A-32 |
| A-32 | Shelf (E2205201) | A-33 |
| A-33 | Spacer (A2205204) | A-34 |
| A-34 | Schematic Diagram, RF-Modulator Marker Beacon (E2205205) | A-35 |
| A-35 | Plate (B2205208) | A-36 |
| A-36 | Handle (B2205209) | A-37 |
| A-37 | Clamp (B2205210) | A-38 |
| A-38 | Schematic Diagram, Main Control Unit (Single) Modifications to Dualized Equipment GS Transmitter No. 1 (E2205211) | A-39 |
| A-39 | Control Unit Front Panel Drilling (C2205213) | A-40 |
| A-40 | Bracket (E2205215) | A-41 |
| A-41 | Washer (B2205216) | A-42 |
| A-42 | Panel, Front (Drilling) (E2205217) | A-43 |
| A-43 | Plate, Calibration (C2205219) | A-44 |
| A-44 | Specification for Marking (A2205220) | A-45 |
| A-45 | Bracket (C2205221) | A-46 |
| A-46 | Schematic Diagram, Monitor Glide Slope Transmitter (E2205223) | A-47 |
| A-47 | Coil (B2205225) | A-48 |
| A-48 | Insulator (B2205226) | A-49 |
| A-49 | Shelf (D2205227) | A-50 |
| A-50 | Schematic Diagram, Remote Control Glide Slope Transmitter (F2205228) | A-51 |

LIST OF ILLUSTRATIONS (contd)

| Figure | | Page |
|--------|--|------|
| A-51 | Schematic Diagram, Local Oscillator GS Field Detector (E2205230) | A-52 |
| A-52 | Bushing (C2205231) | A-53 |
| A-53 | Cable, Round (Modified) (B2205233) | A-54 |
| A-54 | Monitor Front Panel Drilling (C2205241) | A-55 |
| A-55 | Angle (C2205243) | A-56 |
| A-56 | Bracket (D2205244) | A-57 |
| A-57 | Schematic Diagram, Telephone Power Supply (Shelter) (D2205245) | A-58 |
| A-58 | Plate (D2205249) | A-59 |
| A-59 | Adapter, Shaft (B2205250) | A-60 |
| A-60 | Shelf (E2205251) | A-61 |
| A-61 | Schematic Diagram, Intra Cabinet Wiring Glide Slope Transmitter (J2205252) | A-62 |
| A-62 | Panel, Front (Marking) (D2205253) | A-63 |
| A-63 | Panel, Meter (Drilling) (D2205254) | A-64 |
| A-64 | Panel, Meter (Marking) (D2205255) | A-65 |
| A-65 | Panel, Front, Monitor (Marking) (D2205258) | A-66 |
| A-66 | Schematic Diagram, Modulation Control Unit Glide Glide Slope Transmitter (E2205259) | A-67 |
| A-67 | Screw, Thumb (B2205261) | A-68 |
| A-68 | Nut (B2205262) | A-69 |
| A-69 | Panel, Front (Drilling) (E2205263) | A-70 |
| A-70 | Panel, Front (Marking) (E2205264) | A-71 |
| A-71 | Panel, Front (Marking) (E2205265) | A-72 |
| A-72 | Box, Battery (E2205266) | A-73 |
| A-73 | Bracket, Lock (B2205267) | A-74 |
| A-74 | Bracket (B2205268) | A-75 |
| A-75 | Plate (C2205269) | A-76 |
| A-76 | Cover, Battery Box (L2205270) | A-77 |
| A-77 | Hinge (C2205271) | A-78 |
| A-78 | Channel (B2205272) | A-79 |
| A-79 | Support, Angle (C2205273) | A-80 |
| A-80 | Spacer (B2205274) | A-81 |
| A-81 | Strap (A2205275) | A-82 |
| A-82 | Support, Angle (C2205278) | A-83 |
| A-83 | Plate (D2205280) | A-84 |
| A-84 | Plate, Bottom (E2205284) | A-85 |
| A-85 | Box, Inner (J2205286) | A-86 |

LIST OF ILLUSTRATIONS (contd)

| Figure | | Page |
|--------|--|-------|
| A-86 | Shelf (E2205287) | A-87 |
| A-87 | Schematic Diagram, IF Amplifier G.S. Field Detector (J2205295) | A-88 |
| A-88 | Schematic Diagram, Audio Subunit Monitor Glide Slope Transmitter (E2205299) | A-89 |
| A-89 | Panel, Meter (Marking) (D2205306) | A-90 |
| A-90 | Schematic Diagram, Antenna Phase Network G.S. Field Detector (D2205315) | A-91 |
| A-91 | Schematic Diagram, Transmitter Glide Slope Transmitter (E2205319) | A-92 |
| A-92 | Schematic Diagram, Antenna Marker Beacon (D2205318) | A-93 |
| A-93 | Schematic Diagram, Transmitter, Antenna Glide Slope Transmitter (D2205319) | A-94 |
| A-94 | Base, Antenna (D2367300) | A-95 |
| A-95 | Schematic Diagram, Intra Cabinet Wiring Marker Beacon (E2205321) | A-96 |
| A-96 | Nameplate (A2205322) | A-97 |
| A-97 | Nameplate (A2205323) | A-98 |
| A-98 | Printed Wiring Board (Drilled) (D2367315) (Sheet 1 of 3) | A-99 |
| A-98 | Printed Wiring Board (Master) (D2367315) (Sheet 2 of 3) | A-100 |
| A-98 | Printed Wiring Board (Master) (D2367315) (Sheet 3 of 3) | A-101 |
| A-99 | Bracket (C2367316) | A-102 |
| A-100 | Bracket (C2367317) | A-103 |
| A-101 | Spacer (B2367318) | A-104 |
| A-102 | Printed Wiring Board Assembly (D2367319) | A-105 |
| A-103 | Printed Wiring Board (Drilled) (D2367323) (Sheet 1 of 2) | A-106 |
| A-103 | Printed Wiring Board (Master) (D2367323) (Sheet 2 of 2) | A-107 |
| A-104 | Printed Wiring Board Assembly (D2367324) | A-108 |
| A-105 | Bracket, Connector (B2367325) | A-109 |
| A-106 | Bracket, Transformer (B2367326) | A-110 |
| A-107 | Schematic Diagram, Intra Cabinet Wiring GS Field Detector (F2367332) | A-111 |
| A-108 | Schematic Diagram, RF Level Detector GS Transmitter (C2367333) | A-112 |
| A-109 | Shim (B2367335) | A-113 |
| A-110 | Plug, Elbow (B2367348) | A-114 |
| A-111 | Plate, Pickup 150 ~ (Drilled) (D2367350) (Sheet 1 of 3) | A-115 |
| A-111 | Plate, Pickup 150 ~ (Master) (D2367350) (Sheet 2 of 3) | A-116 |
| A-111 | Plate, Pickup 150 ~ (Master) (D2367350) (Sheet 3 of 3) | A-117 |

LIST OF ILLUSTRATIONS (contd)

| Figure | | Page |
|--------|---|-------|
| A-112 | Plate, Pickup, 90 ~ (Drilled)(D2367351) (Sheet 1 of 3) . . . | A-118 |
| A-112 | Plate, Pickup, 90 ~ (Master)(D2367351) (Sheet 2 of 3) . . . | A-119 |
| A-112 | Plate, Pickup, 90 ~ (Master)(D2367351) (Sheet 3 of 3) . . . | A-120 |
| A-113 | Rotor, 150 ~ (C2367352) | A-121 |
| A-114 | Rotor, 90 ~ (C2367353) | A-122 |
| A-115 | Clamp, Tuning (B2367354) | A-123 |
| A-116 | Spacer, Bearing (B2367355) | A-124 |
| A-117 | Shaft (B2367356) | A-125 |
| A-118 | Plate, Mounting (C2367357) | A-126 |
| A-119 | Spacer, Capacitor, Input (B2367358) | A-127 |
| A-120 | Stud, Connector (B2367359) | A-128 |
| A-121 | Capacitor, Input (B2367361) | A-129 |
| A-122 | Capacitor, Output (B2367362) | A-130 |
| A-123 | Rod, Tuning (B2367363) | A-131 |
| A-124 | Rod, Coupling (B2367364) | A-132 |
| A-125 | Bushing, Tuning (B2367365) | A-133 |
| A-126 | Hub, Rotor (B2367366) | A-134 |
| A-127 | Sleeve, Tuning, Inner (B2367367) | A-135 |
| A-128 | Housing, Input (C2367368) | A-136 |
| A-129 | Housing, Output (D2367369) | A-137 |
| A-130 | Sideband Generator Assembly (A2367370) (Sheet 1 of 3) . . . | A-138 |
| A-130 | Sideband Generator Assembly (A2367370) (Sheet 2 of 3) . . . | A-139 |
| A-130 | Sideband Generator Assembly (A2367370) (Sheet 3 of 3) . . . | A-140 |
| A-131 | Washer, Spring (B2367371) | A-141 |
| A-132 | Block, Motor (B2367372) | A-142 |
| A-133 | Insulator (B2367373) | A-143 |
| A-134 | Printed Wiring Board (Drilled) (B2367380) (Sheet 1 of 2) . . . | A-144 |
| A-134 | Printed Wiring Board (Master) (A2367380) (Sheet 2 of 2) . . . | A-145 |
| A-135 | Printed Wiring Board (Assembly) (C2367381) | A-146 |
| A-136 | Screen (C2367387) | A-147 |
| A-137 | Insulator (B2367389) | A-148 |
| A-138 | Schematic Diagram, Tone Generator and Keyer Marker Beacon (J2367391) | A-149 |
| A-139 | Bracket (D2367405) | A-150 |
| A-140 | Low Cost Glide Slope (D2367439) | A-151 |

LIST OF ILLUSTRATIONS (contd)

| Figure | | Page |
|--------|--|-------|
| A-141 | ILS Ground Plane Drilling Diagram (BX2205292) | A-152 |
| A-142 | ILS Ground Plane Drilling Diagram (BX2205293) | A-153 |
| A-143 | ILS Ground Plane Bending Diagram (CX2205294) | A-154 |
| A-144 | Connector Mounting Bracket (BX2205297) | A-155 |
| A-145 | Sleeve, Mounting (BX2205298) | A-156 |
| A-146 | Screw, Modified BX2205302) | A-157 |
| A-147 | Insulating Spacer (BX2205303) | A-158 |
| A-148 | Conducting Spacer (BX2205304) | A-159 |
| A-149 | Threaded Plug (BX2205305) | A-160 |
| A-150 | Insulator (BX2205307) | A-161 |
| A-151 | Element, Transmitting (BX2205308) | A-162 |
| A-152 | Cable Clamp, Tee (BX2205310) | A-163 |
| A-153 | Cover Plate (BX2205311) | A-164 |
| A-154 | Clamp Grounding (BX2205312) | A-165 |
| A-155 | Center Conductor Connector (BX2205313) | A-166 |
| A-156 | Element, Monitor (BX2205314) | A-167 |
| A-157 | Matching Network (CX2205317) | A-168 |
| A-158 | Tube, Feed (BX2157307) | A-169 |
| A-159 | Tube, Dipole (BX2157308) | A-170 |
| A-160 | Cap, End (BX2157309) | A-171 |
| A-161 | Plate, MTG (BX2157310) | A-172 |
| A-162 | Spacer (BX2157311) | A-173 |
| A-163 | Center Conductor Assembly (BX2157323) | A-174 |
| A-164 | Outer Conductor (BX2157327) | A-175 |
| A-165 | Feed Point Lug (BX2157329) | A-176 |
| A-166 | Dipole Soldering Assembly (DX2157330) | A-177 |
| A-167 | ILS Glide Slope Dipole (DX2157331) | A-178 |
| A-168 | Seal, Connector (BX2157344) | A-179 |
| A-169 | Transformer Outer Conductor (BX2367320) | A-180 |
| A-170 | Transformer Inner Conductor (BX2367321) | A-181 |
| A-171 | Transformer, Coaxial, Dielectric (BX2367322) | A-182 |
| A-172 | Insulating Spacer, Monitor (BX2367327) | A-183 |
| A-173 | Center Conductor Connector (Small) (BX2367328) | A-184 |
| A-174 | Grounding Plate (BX2367329) | A-185 |
| A-175 | Mounting Plate, Ground (BX2367330) | A-186 |
| A-176 | Support Tube (CX2367383) | A-187 |
| A-177 | Sub-Sideband Generator Input (AX2367432) | A-188 |

LIST OF TABLES

| Table | | Page |
|-------|--|------|
| I | INPUT VSWR OF GLIDE SLOPE TRANSMITTING ANTENNA ASSEMBLIES | 13 |
| II | GLIDE SLOPE MONITOR ANTENNA TEST RESULTS | 15 |
| III | MINIMUM SENSITIVITY FOR ua METER INDICATION AS A FUNCTION OF DIFFERENT 1N21B DIODES | 20 |
| IV | TEST DATA FOR AUDIO SUBUNIT TEMPERATURE TESTS | 21 |
| V | TEST DATA FOR GROUND MEASUREMENTS AND FLIGHT CHECKS | 27 |
| VI | MARKER BEACON HARMONIC DISTORTION VERSUS TEMPERATURE | 38 |
| VII | MARKER BEACON SPURIOUS AND HARMONIC FREQUENCIES | 40 |
| VIII | TONE GENERATOR OUTPUT VERSUS PERCENT MODULATION | 43 |
| IX | ALARM RELAY THRESHOLD VERSUS TEMPERATURE | 44 |
| X | MARKER BEACON FLIGHT CHECK DATA | 47 |

INTRODUCTION

The Low Cost ILS Glide Slope and Marker System was developed under Contract No. FA-WA-4474 to provide a highly reliable equipment which could be procured, installed and maintained at substantially less cost than previous systems. This objective has been achieved by the development of a transistorized glide slope system, which is factory installed in a portable shelter to minimize installation costs. A marker beacon system is housed in a weatherproof shelter and is mounted together with the antenna array on a single telephone pole.

The glide slope and marker systems have been designed to best commercial grade specifications and meet the performance requirements of ICAO Category I standards. Thus the electronics is less costly than previous ILS systems built and tested to the detailed requirements of the R-777 specification.

The fact that the glide slope equipment is delivered installed in a portable shelter results in a great savings in on-site construction costs. It has been estimated that the cost of construction in conventional ILS installations is greater than the cost of the electronics it is to house.⁽¹⁾ In the case of the marker beacon, previous systems required two telephone poles for mounting while the low cost system requires only a single pole with a commensurate savings.

The third reduction factor in the Low Cost ILS Glide Slope and Markers System is reduced maintenance costs. Modular construction has been emphasized throughout the system as an aid to maintenance personnel in troubleshooting and reduction in down-time necessary for repairs. The incorporation of transistors throughout the design will in itself minimize the occurrence of failure and thus reduce the costs of maintaining the equipment.

This report presents the theory of operation and all pertinent engineering data on the Low Cost ILS Glide Slope System TU-8X and the low cost ILS Marker Beacon Transmitter TV-33X.

(1) S.B. Poritzky, "The Facility Cost Problem", Journal of ATC, September 1963

FUNCTIONAL OPERATION OF THE GLIDE SLOPE SYSTEM

(1) Transmitter Unit

The transmitter unit appears as part of the glide slope system block diagram shown in Figure 1. The exciter sub-unit consists of an all-transistorized RF multiplier and amplifier chain. The first stage of the amplifier chain is a crystal oscillator whose output is in the 27.4 to 27.9 mc band. The frequency output is applied to two successive doubler stages, and thus is quadrupled to 110 mc. Two successive stages of power amplification are then utilized to achieve the necessary 2.5 watt level to drive the tripler cavity. As shown in the block diagram, the final tripler and power amplifier is an RF cavity assembly, which multiplies the 110 mc frequency to the 330 mc glide slope band, and generates the power necessary to drive the modulation and antenna feed networks.

(2) Sideband Generator

The sideband generator is a constant impedance modulator using a synchronous motor to drive the tone generating rotor elements. The 90 and 150 cps modulation is derived from these rotor elements, one set containing three lobes and another set containing five lobes. A single three lobe and a single five lobe section provides the modulation energy, while the second three lobe and five lobe elements are so oriented that they generate the conjugate impedance over the modulation cycle, thus allowing the net input impedance of the sideband generator to nominally a constant resistive value. The output of each modulator section consists of a pair of sidebands centered about the carrier frequency.

(3) Modulation Control Panel

The modulation control panel consists of a group of phasers and hybrid bridges which perform the necessary signal processing to produce the required antenna excitation signals.

(4) Transmitting Antenna System

The transmitting antenna for the glide slope system, consists of a conventional Null-Reference image antenna array, utilizing ground reflections to form the Glide Slope pattern. Dual element antennas are used to enhance system performance by sharpening the beam, in azimuth, thus reducing siting effects.

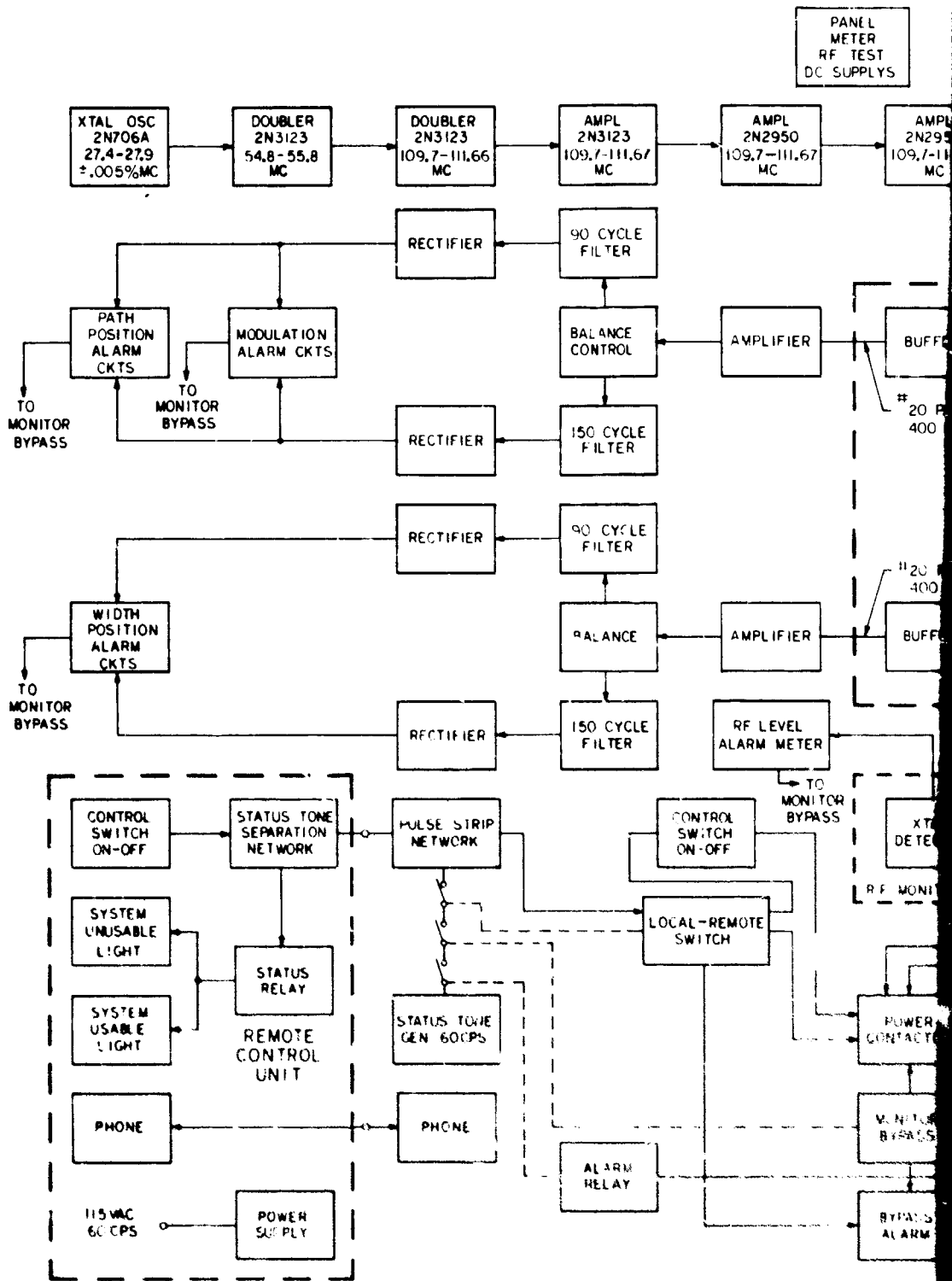

A

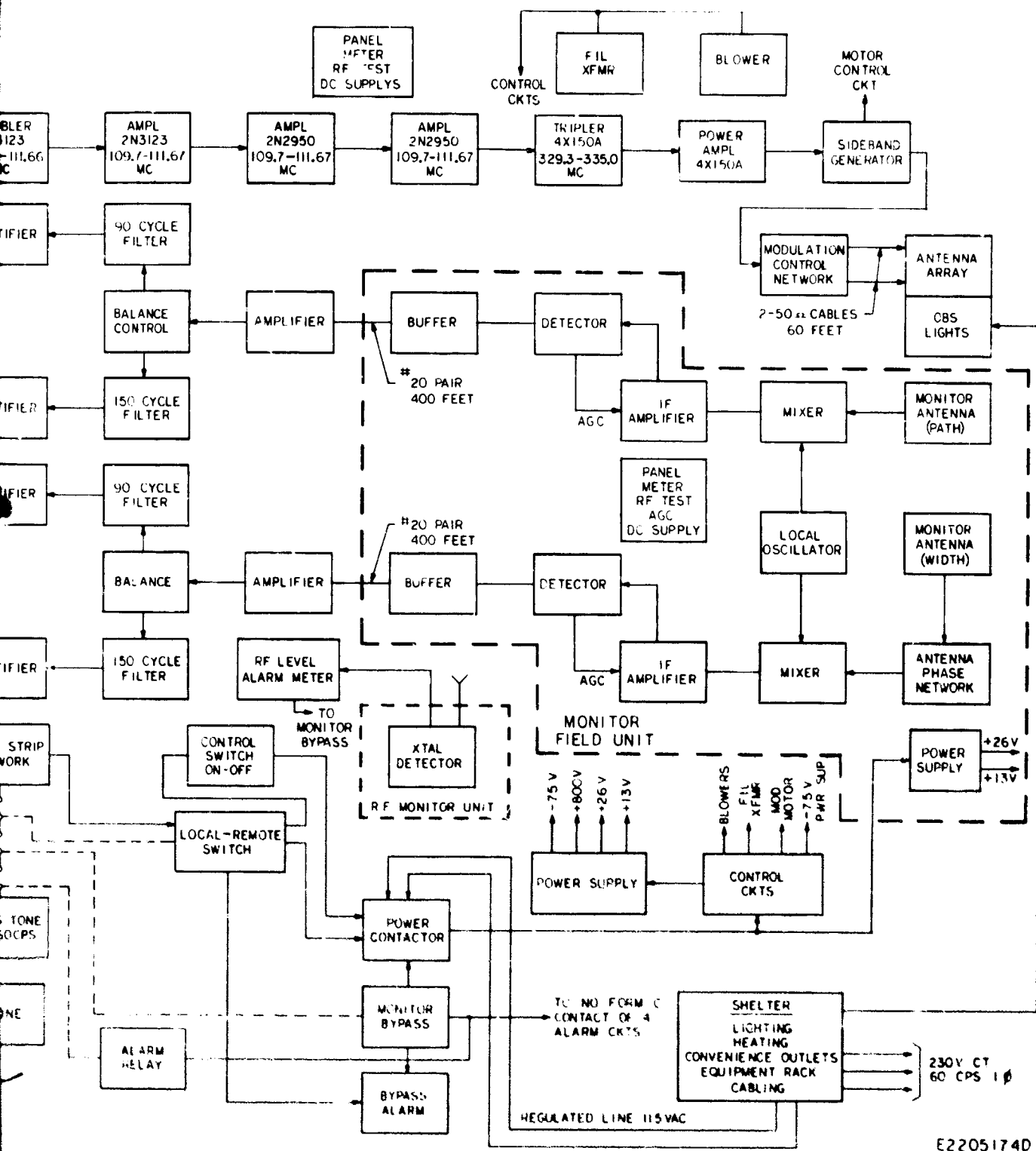

Figure 1. Glide Slope Block Diagram

B

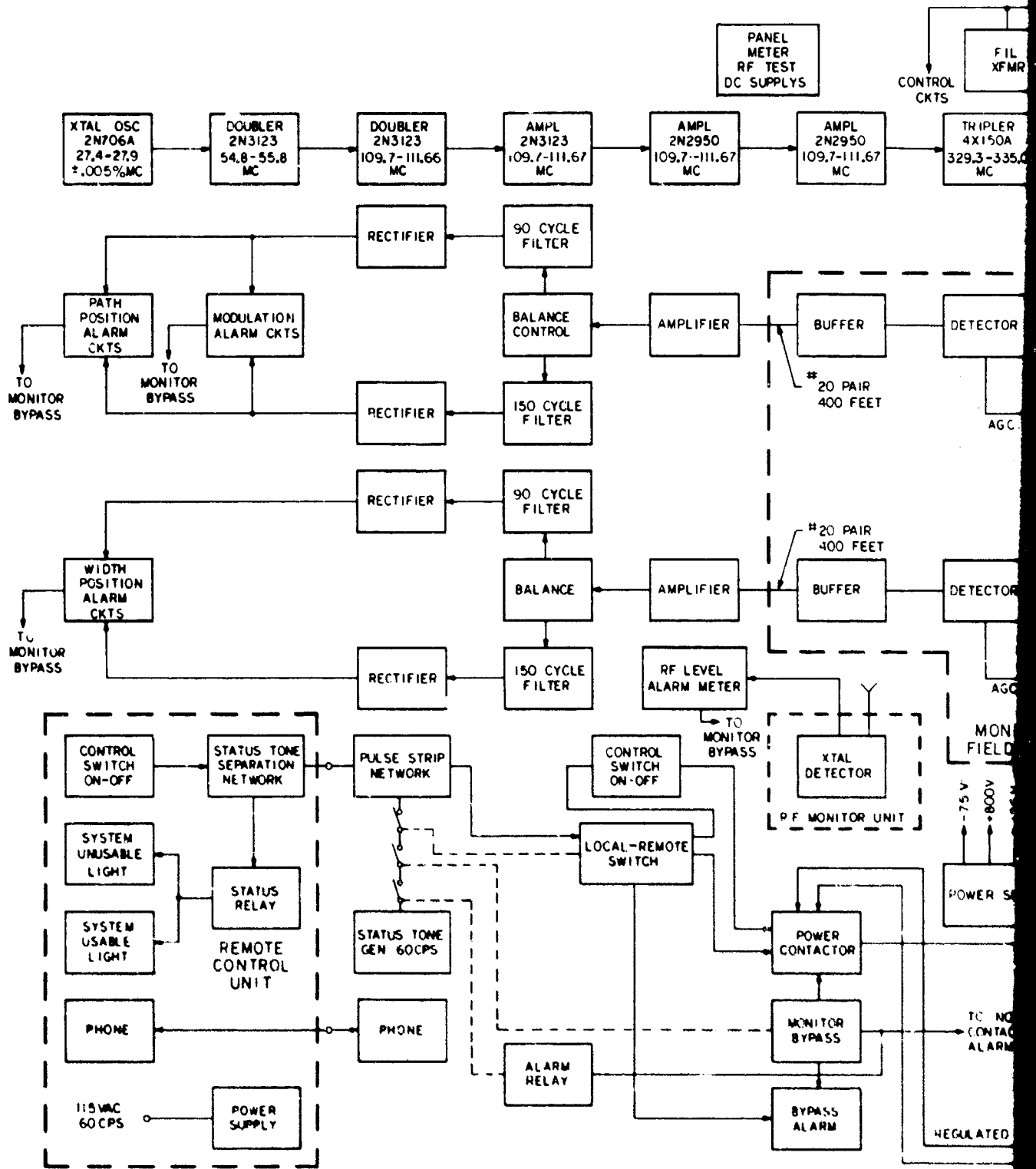
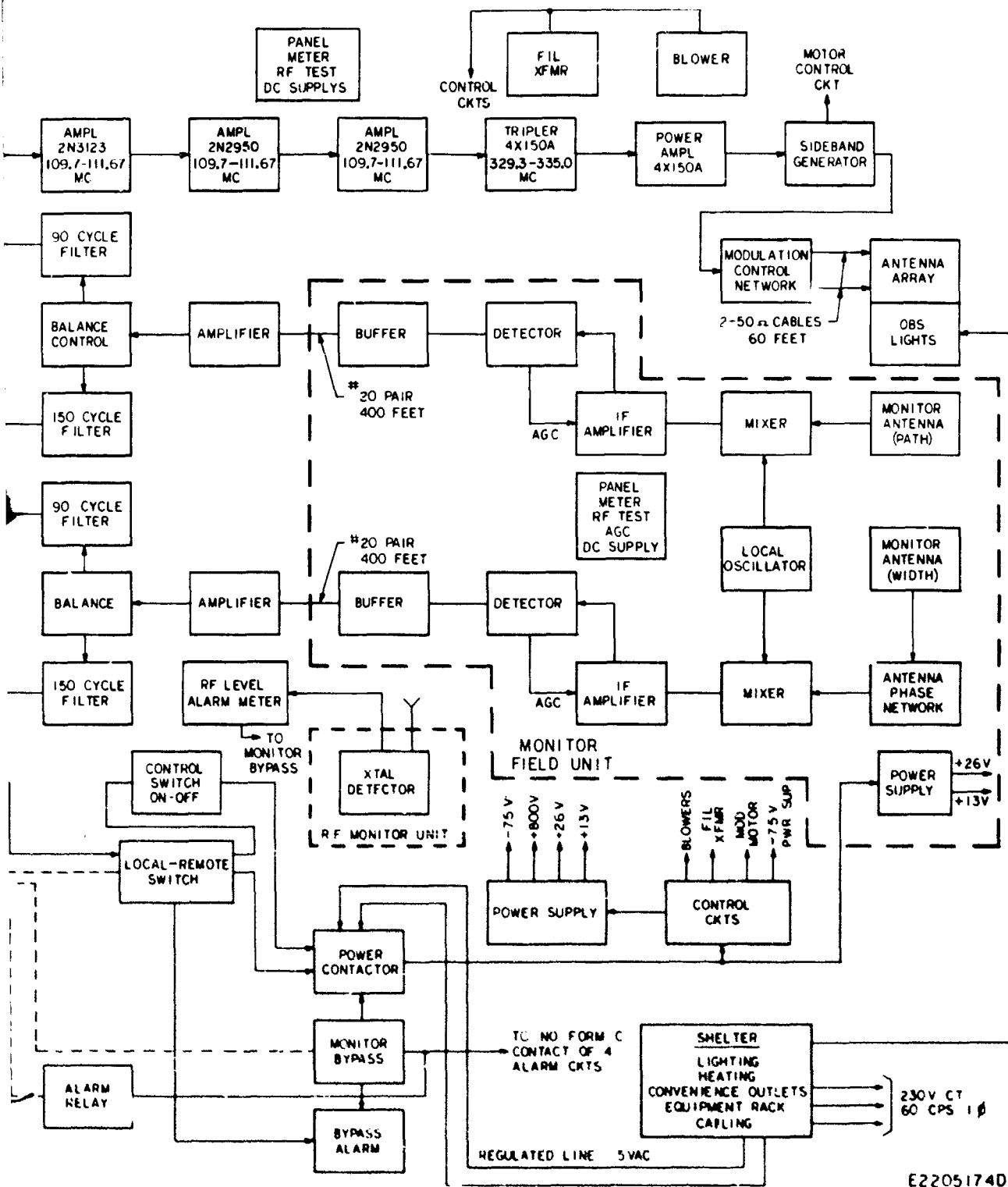

Figure 1. Glide Slope Block Diagram

A



E22051740

B

(5) Field Detector Antenna System

The field detector antenna system consists of three monitor antennas each mounted on an aluminum pipe mast.

The position monitor antenna is a single dipole element centrally located on path.

The RF level monitoring antenna is also a single dipole element, positioned in the radiated field to reliably monitor the energy radiated from the transmitting array.

The width monitor antenna is a twin antenna system, with one dipole element located above path and a second dipole element symmetrically located below path. This twin antenna system has the advantage of making the width determination nearly independent of path position variations.

(6) Field Detector Unit

The outputs of the position and width monitor antennas are processed in the field detector unit. The field detector is a dual channel superheterodyne receiver with a common local oscillator. These IF channels have extremely tight agc characteristics so that the audio output of each is proportional only to the percent modulation of the incoming signal. The outputs of the field detector from both the position and width channels consist of composite 90 and 150 cps audio signals, which are fed through land lines back to the monitor unit, located in the shelter. The antenna phase network at the input to the width monitor channel, combines the signals from the two width monitor antennas in proper phase to feed the width IF channel.

(7) Monitor Unit

The glide slope monitor unit, located in the shelter, consists of audio amplification, filtering, and sum and difference circuits. These circuits process the detected audio from the field detector and present the data on appropriate monitoring meter relays. The unit has two channels; one of which is used for processing position data and the other for width data. An audio amplifier provides amplification of the detected audio signal from the field detector. This amplifier uses feedback to obtain a high degree of stability. The output is fed through a balance circuit to the 90 and 150 cps sections of the dual monitor filter. The balance control cancels differences in attenuation of the two filter sections. The output of the 90 and 150 cps filter sections are then individually rectified and processed by resistor differencing and summing networks to drive

meter relay indicating devices. In the position channel, a meter relay movement is located in a differencing circuit between the 90 and 150 cps rectified filter outputs. This zero-centered meter indicates position deviations of the glide slope by corresponding deviations of the meter. The same rectified outputs of the position channel are also summed and fed to a second meter. This meter indicates the percent modulation of the composite signal. Alarm limits are set on both the position and modulation parameters by mechanical adjustments in the meter housings. In the width channel, the antenna signal is processed at the field detector so that the carrier and sideband energy are in phase regardless of the width antenna location, and the sideband output is the average value of the levels in the antennas. The width meter deflection is therefore nearly independent of path position and is obtained by summing this average value of the 90 and 150 cps sidebands. An increase in meter deflection indicates a decrease in width and a decrease indicates an increase in width.

(8) Control Circuits

The control circuits consist of conventional relay logic circuitry. The functions of the control circuits are as follows:

- (a) Provide sequencing of the filament supply and various power supplies for protection of equipment during turn-on and turn-off.
- (b) Provide a means for sensing the alarm relay status, and for stopping transmission in the event that guidance information is not in accordance with specifications.
- (c) Provide for automatic restart of the transmitter in case of power line failure (either permanent or momentary) which may occur during equipment operation.
- (d) Provide a means for remote control of the equipment.
- (e) Provide a means for relaying the status of the equipment to a remote location.
- (f) Provide a means for local control of the equipment.
- (g) Provide a means for bypassing monitor operation.

(9) Tower Unit

The tower unit circuitry consists of the switches and indicating devices necessary to remotely control the operation of the glide slope transmitter. Remote control of the transmitter is achieved by applying an impulse to the land line connecting the tower unit and the control unit of the glide slope transmitter. This line also carries the status tone for the remote status indication. A separate telephone line is also included as part of the tower unit. The telephone is on the work bench in the equipment shelter. The connecting telephone

in the control tower may be located in the most convenient place. A standby battery is provided in the shelter so that the telephones may still be used during power failures.

(10) Power Supplies

The high voltage power supply is a rack-mounted panel unit. All other power supplies used in the glide slope equipment are small, all-transistorized plug-in power supplies. Individual units have self-contained supplies in the glide slope equipment cabinet. The monitor unit uses a +150 vdc sub-unit supply and a +26 vdc supply. The transmitter unit has a -75 vdc power supply and a +13 vdc power supply. The field monitor uses a +26 vdc supply and a +13 vdc supply, both remotely controlled by the control circuits in the transmitter cabinet. The telephone unit in the shelter of the remote control unit uses a small self-contained 3 vdc unregulated power supply. In addition to this power supply, the telephone box located in the equipment shelter contains a 3 vdc standby battery supply for emergency operation in the event of power line failure. All equipment inputs are designed for 115 vdc, single phase, 60 cps operation, which is derived from the center tap of the 230 vdc, single phase, 60 cps input to the equipment shelter. All of the power supplies are regulated against load and line fluctuations. In addition, the filament transformers used in the transmitter unit are magnetically regulated units and, therefore, no central line regulators are required in the equipment.

(11) Equipment Shelter

The equipment shelter provides a self-contained permanent weatherproof housing for the transmitter cabinet. The shelter is provided with steel skids for handling the siting of the unit. No site preparation is necessary for locating the shelter. The shelter can be located on level terrain at the appropriate location on the air field. The shelter provides the lighting, heating, convenience outlets, work space, and storage area necessary for maintenance of the equipment. A circuit breaker box is provided to control the ac power inputs and distribution of the inputs in the equipment shelter. A separate ac circuit breaker box is provided for operation of the obstruction lights from the airport lighting circuit or, direct from the main inputs to the glide slope equipment shelter.

FUNCTIONAL OPERATION OF THE MARKER BEACON

The following paragraphs provide a detailed functional description of the marker beacon system. A block diagram of this system appears in figure 2 (D2205175).

(1) RF - Modulator

The basic RF frequency-generating circuit in the marker beacon system is the RF-modulator crystal oscillator, which generates a 37.5 mc signal. The oscillator output is applied to a frequency doubler circuit, producing an output frequency at the desired 75 mc. This 75 mc output is then amplified in a driver stage which supplies the necessary gain for the power amplifier unit.

The audio circuitry of the marker beacon system consists of generator and modulator. The modulator is contained in the RF modulator subunit and is comprised of a stabilized ac amplifier. This amplifier drives a modulation transformer whose output is arranged to collector-modulate the output of both the power amplifier and the driver in the transmitter chain. The modulator also contains percent modulation monitoring circuitry which is comprised of a negative peak detector monitoring the percent modulation of the audio signal. This percent modulation monitoring circuit is fed back to the tone generator as an agc signal. Thus, the tone generator and modulator are within a closed agc loop and the percent modulation is maintained at the desired value.

(2) Tone Generator

The tone generator is comprised of a conventional LC transistorized oscillator and an electronic attenuator. The attenuator contains a photo-sensitive element which varies the output of the tone generator. The tone generator oscillator output is fed to this electronic attenuator, whose attenuation is a function of the percent modulation feedback voltage. The attenuator output is then buffered and fed to the modulator. The tone generator frequency is selected by means of an external jumper connection.

(3) Keyer

The marker beacon keyer subunit provides the necessary identification signal for the marker beacon radiated pattern. The keyer is comprised of a unijunction pulse generator, a multivibrator, a two-stage counter, and the necessary gating circuitry. The two-stage counter is connected to count to the base three. The gating circuitry extracts the dot and dash information and combines the dot and dash channels to provide the dot-dash identification signals. The keyer identification signal is selected by an external connection. This selected output of the keyer is fed to the tone generator where it is used to key the tone oscillator.

(4) Monitor

The marker beacon monitor subunit detects the RF level of the antenna signal and also the presence of tone modulation and keying in the system. A crystal detector detects the RF picked up by a small monitor antenna stub

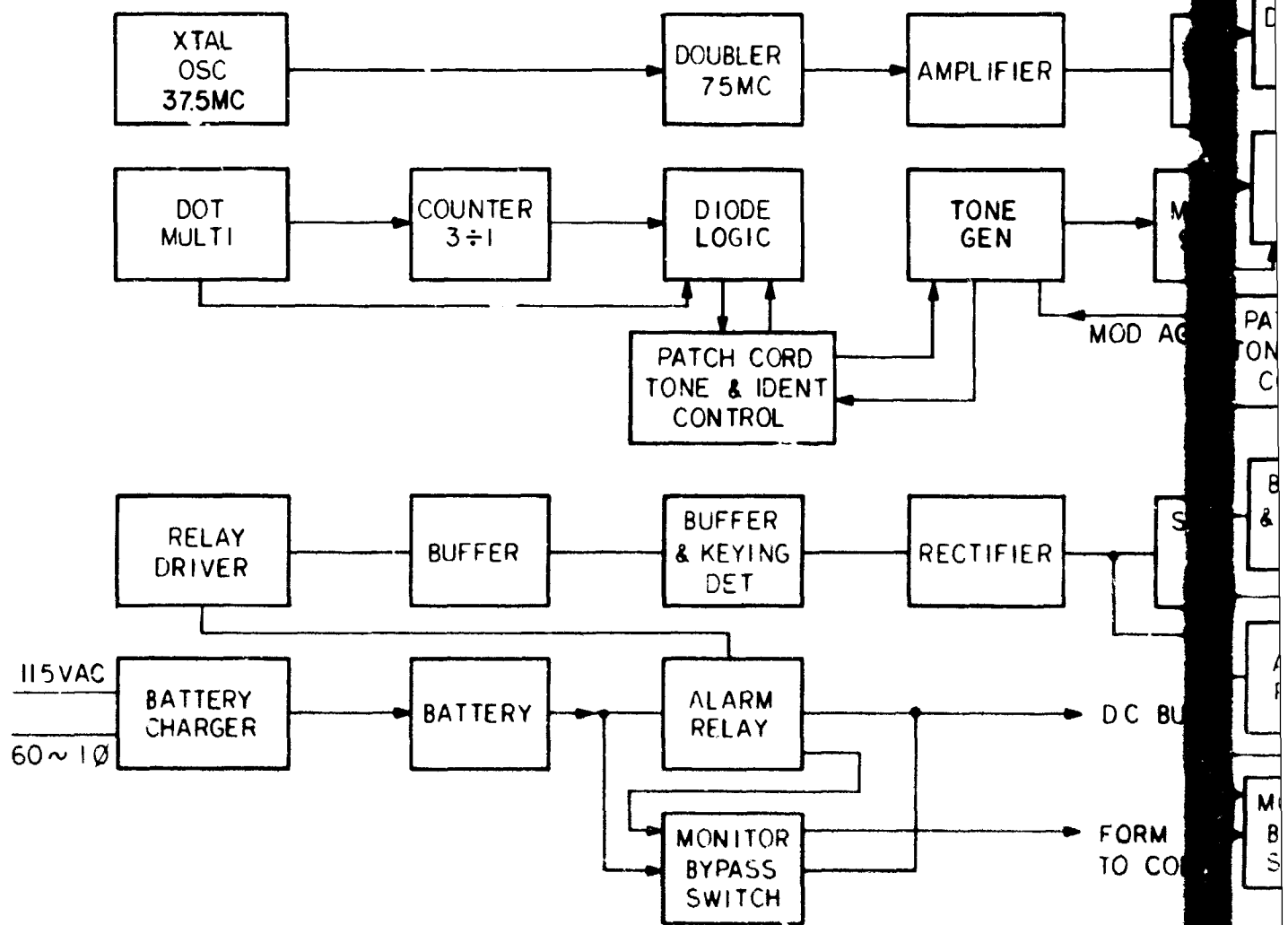

A

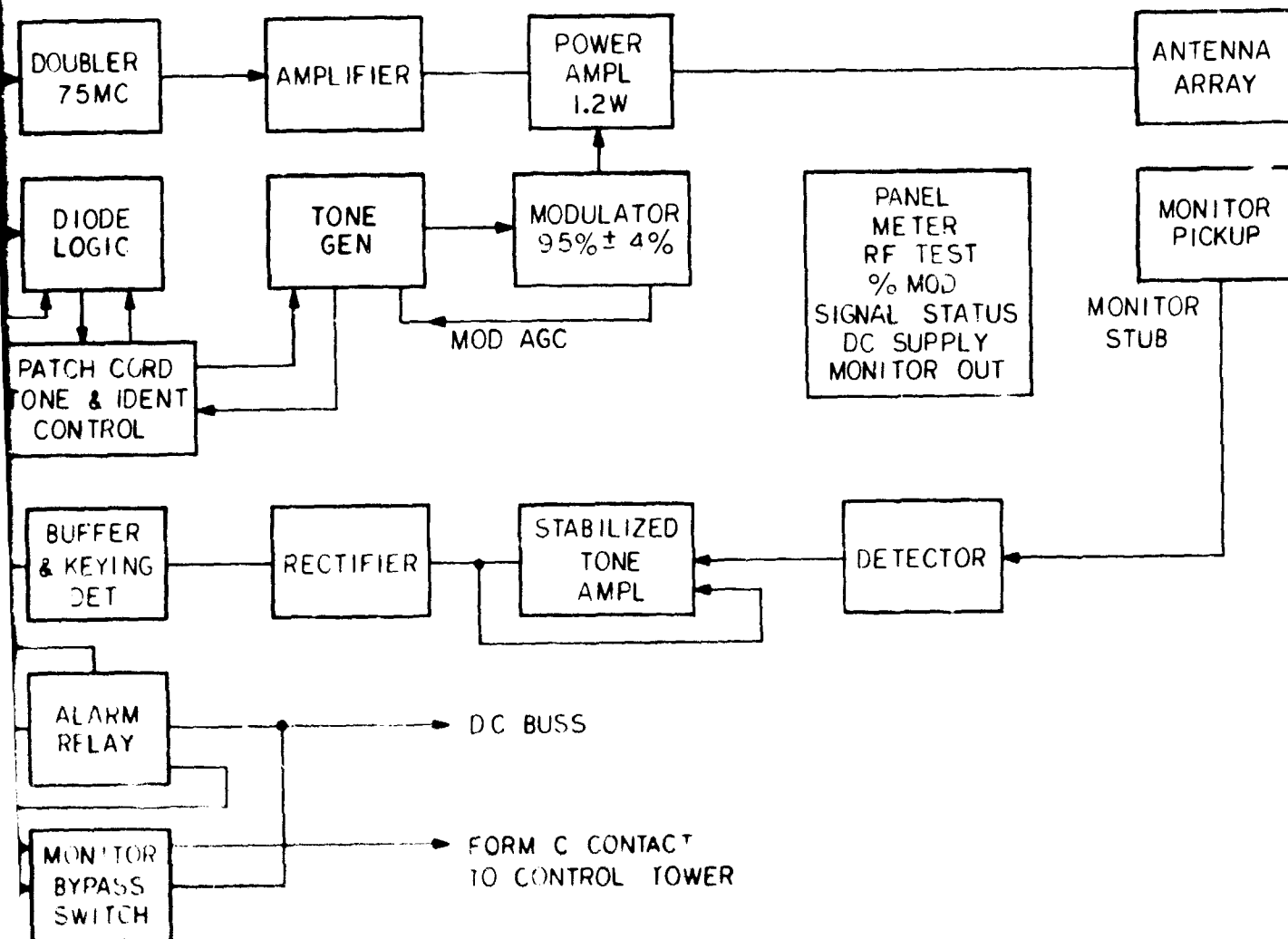

Figure 2. Marker Beacon Block Diagram

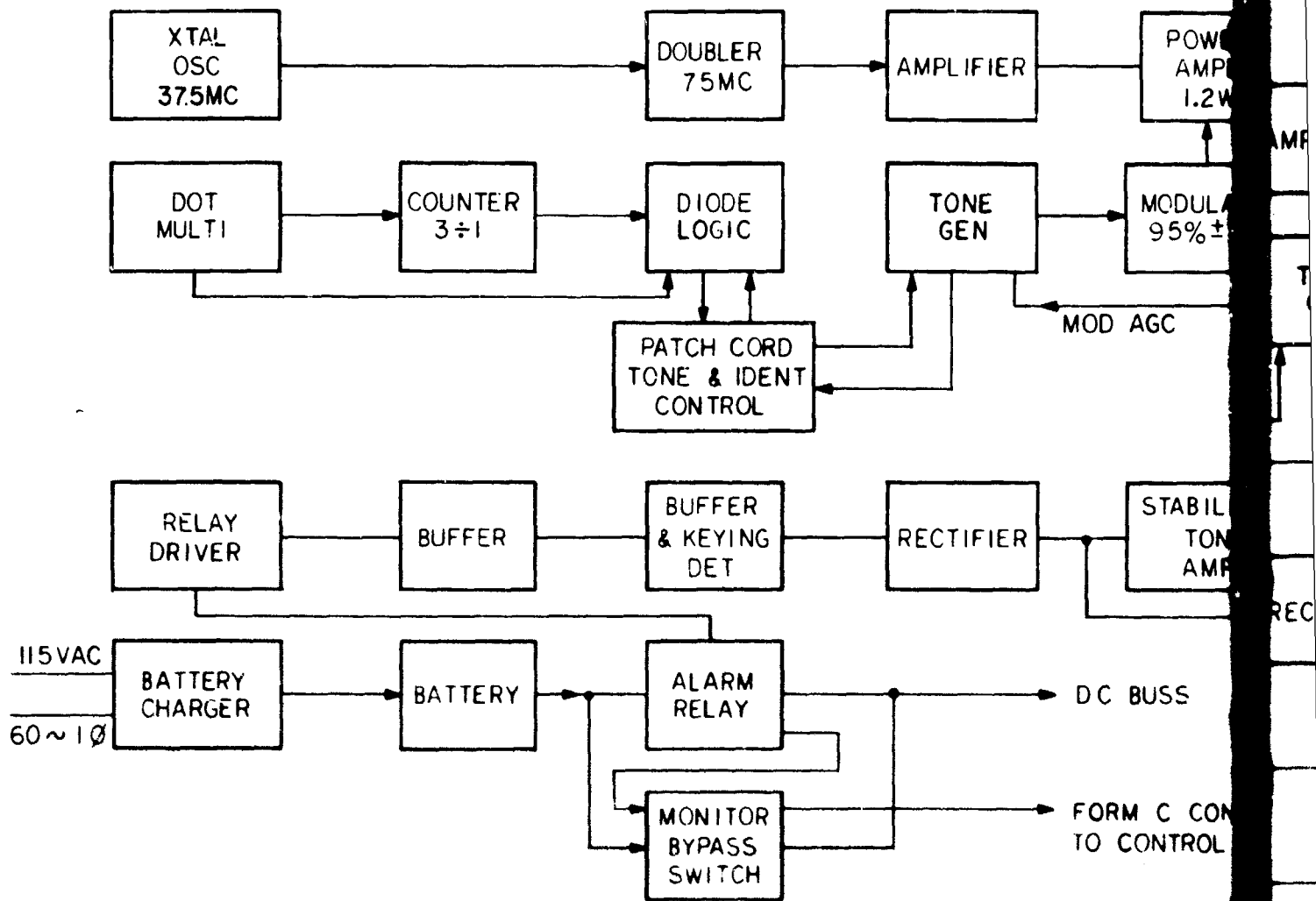
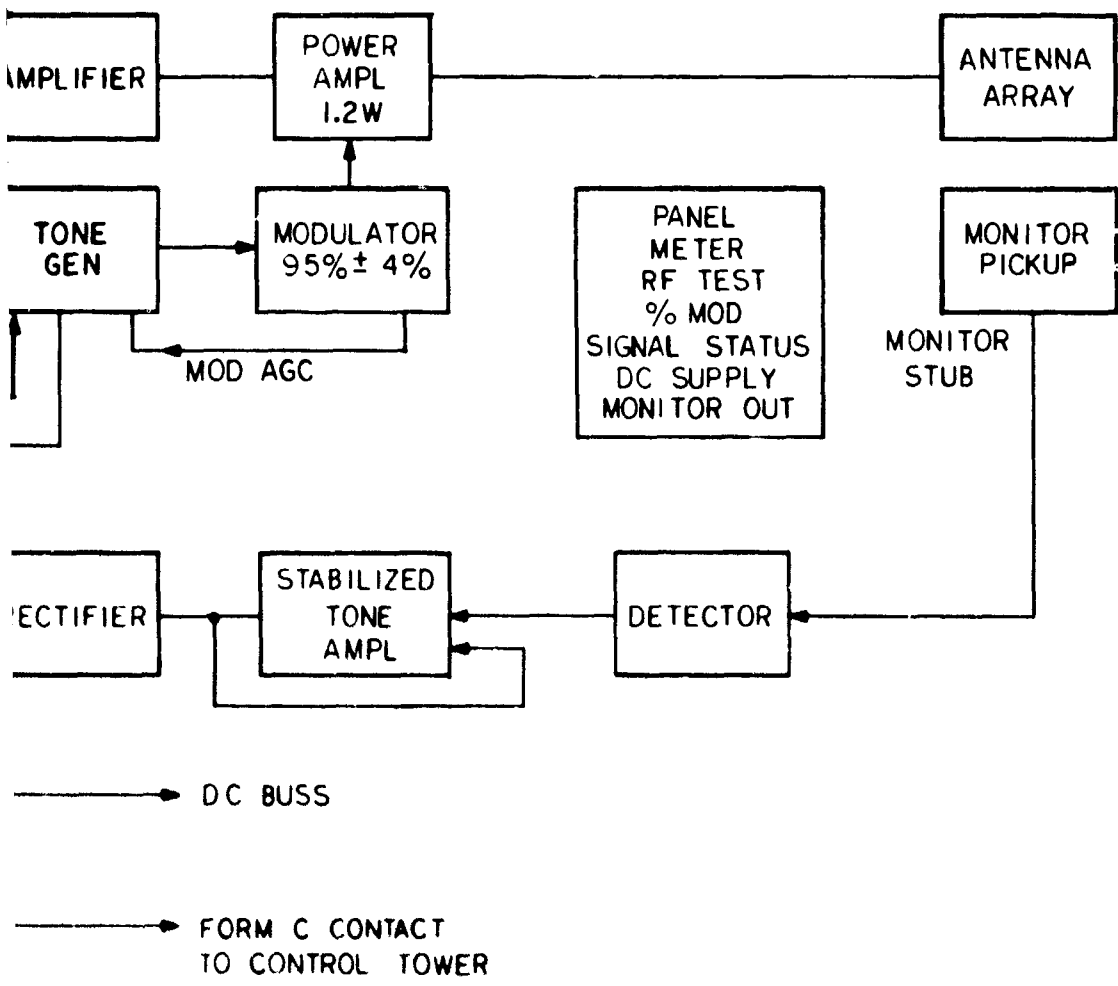

Figure 2. Marker Beacon Block Diagram

A



B

located in the antenna mast directly below the main radiating element. The detected audio output from the crystal detector is applied to an audio amplifier. The audio amplifier output is stabilized by feedback, which makes it basically insensitive to open loop gain within the amplifier, as well as to the effects of ambient temperature. The audio amplifier amplifies the detected audio signal to levels sufficient to drive a rectifier. The rectified and filtered audio signal is then fed to a buffer circuit. The keying detector consists of a large coupling capacitor which does not respond to any dc in the keying waveform. If the keying is not present, the signal is not transmitted beyond this keying detector. The second buffer integrates the keyed audio waveform to a dc level sufficient to operate the relay driver. The relay driver energizes the alarm relay, which is an extremely low differential multipole relay. The relay package contains threshold sensing circuitry so that its pick-up-to-dropout ratio is below 0.3 db. This provides a very tight and accurate threshold setting of the monitor.

(5) Control Circuits and Metering

The alarm relay of the marker beacon monitor provides failsafe operation. Therefore, to indicate a signal good condition, the relay must be energized. Failure of the relay to energize removes the signal good condition and automatically remotes this status back to the control tower. The MONITOR switch allows for maintenance to be performed on the system when failure occurs. This switch bypasses the lock-out circuit of the alarm relay, and energizes the electronic circuitry despite alarm conditions. The alarm relay operation is such that when an alarm is indicated by the electronic circuitry and the relay is de-energized, the unit must be reset manually to reestablish the alarm monitoring. This is accomplished by cycling the MONITOR switch. Power interruption and lockout of the unit is accomplished directly through contacts on the alarm relay, since the 13 vdc input voltage from the battery system is supplied directly through a contact of the alarm relay to the electronic circuitry of the monitor unit.

A control panel is provided in the marker beacon housing which contains a meter and its associated switches. Multimeter connections are made to this meter through a selector switch. This panel meter monitors the following:

- (a) Transmitter RF output
- (b) Percent modulation
- (c) Battery supply voltage
- (d) Status good signal
- (e) Monitor output

(6) Antenna System

The marker beacon antenna is an array of two dipoles which are phased to direct most of the radiated energy above the horizontal. The antenna pattern is essentially constant for vertical angles above 20° with the horizontal. The results in a reduction of power required out of the transmitter since energy is not wasted at high angles but is more equally distributed over the lower angles which determine the marker beacon pattern width.

A small pick-up stub is also mounted on the marker beacon antenna mast to sample the radiated pattern for monitoring purposes.

GLIDE SLOPE SYSTEM ENGINEERING DATA

(1) Antenna System

The glide slope antenna system consists of three transmitting antenna assemblies and four monitor antenna assemblies. Two of the transmitting antenna assemblies are used to form a standard null reference glide slope. The third is supplied for optional conversion to other arrays, such as the M-array, at problem sites. The antenna feed network supplied is for null-reference operation only. The monitor antenna assemblies sample the radiated signal for the signal level, path position, and path width monitors.

The transmitting antenna assemblies consist of two horizontal, colinear half wavelength dipoles, one-quarter wavelength from a vertical ground plane. The spacing between dipole centers is 26 inches or 263° at 332 mc and the dipoles are excited with equal in-phase amplitudes. This provides greater horizontal directivity than previous glide slope antenna systems. This greater directivity is desirable for reducing the effect of reflecting objects located on either side of the approach path.

The monitor antenna assemblies are single horizontal half wavelength dipoles, one-quarter wavelength from a vertical ground plane.

Measurements made on the transmitting antenna bays included plots of the pattern produced in the horizontal plane, and the input VSWR. Both measurements were made at 329 mc, 332 mc, and 335 mc representing the lower end, middle, and upper end of the glide slope band.

The horizontal patterns were obtained by rotating the antenna bays above a fixed point with the receiving antenna at a fixed location. A crystal diode mixer and an IF amplifier were used as receiving equipment, therefore the vertical coordinate of the plot corresponds to radiated field intensity (voltage).

Due to initial velocity diode current in the IF amplifier, there exists a slight non-linearity in the receiver at very low signal levels. As a result the plotted pattern can never reach zero, therefore two horizontal base lines are recorded, one representing the level of initial velocity diode current, the other zero input to the recorder. For signal levels greater than 10% of full scale, this non-linearity is of no significance.

The horizontal ordinate of the plot represents horizontal angle with 0° being the line perpendicular to the antenna ground plane. The patterns obtained are shown in figure 3.

In all antennas the signal level was more than 5 db below the peak value at 25° or more with very deep nulls occurring between 46° and 48°. At angles greater than 50° there is only a small amount of energy.

The input voltage standing wave ratios with respect to 50 ohms are found in table 1. These measurements were made with a Rohde and Schwarz Z-g diagraph. All VSWR's measured present a satisfactory load to the transmitter.

TABLE I - INPUT VSWR OF GLIDE SLOPE TRANSMITTING ANTENNA ASSEMBLIES

| Frequency (mc) | VSWR at 50 ohms | | |
|----------------|-----------------|-------------|-------------|
| | Assembly #1 | Assembly #2 | Assembly #3 |
| 329 | 1.02:1 | 1.13:1 | 1.00:1 |
| 332 | 1.01:1 | 1.12:1 | 1.00:1 |
| 335 | 1.00:1 | 1.11:1 | 1.00:1 |

The only electrical measurement made on the glide slope monitor antennas was the input voltage standing wave ratios. A Rohde and Schwarz Z-g diagraph with a reference impedance of 50 ohms was used for this measurement. The results are tabulated in table II.

(2) Glide Slope Transmitter TU-8X

The glide slope cabinet contains all the electronic components necessary to generate, modulate, and distribute the RF energy required to feed a null-reference antenna system. The general philosophy employed in the development was to lay out a paper design, purchase the necessary components, construct

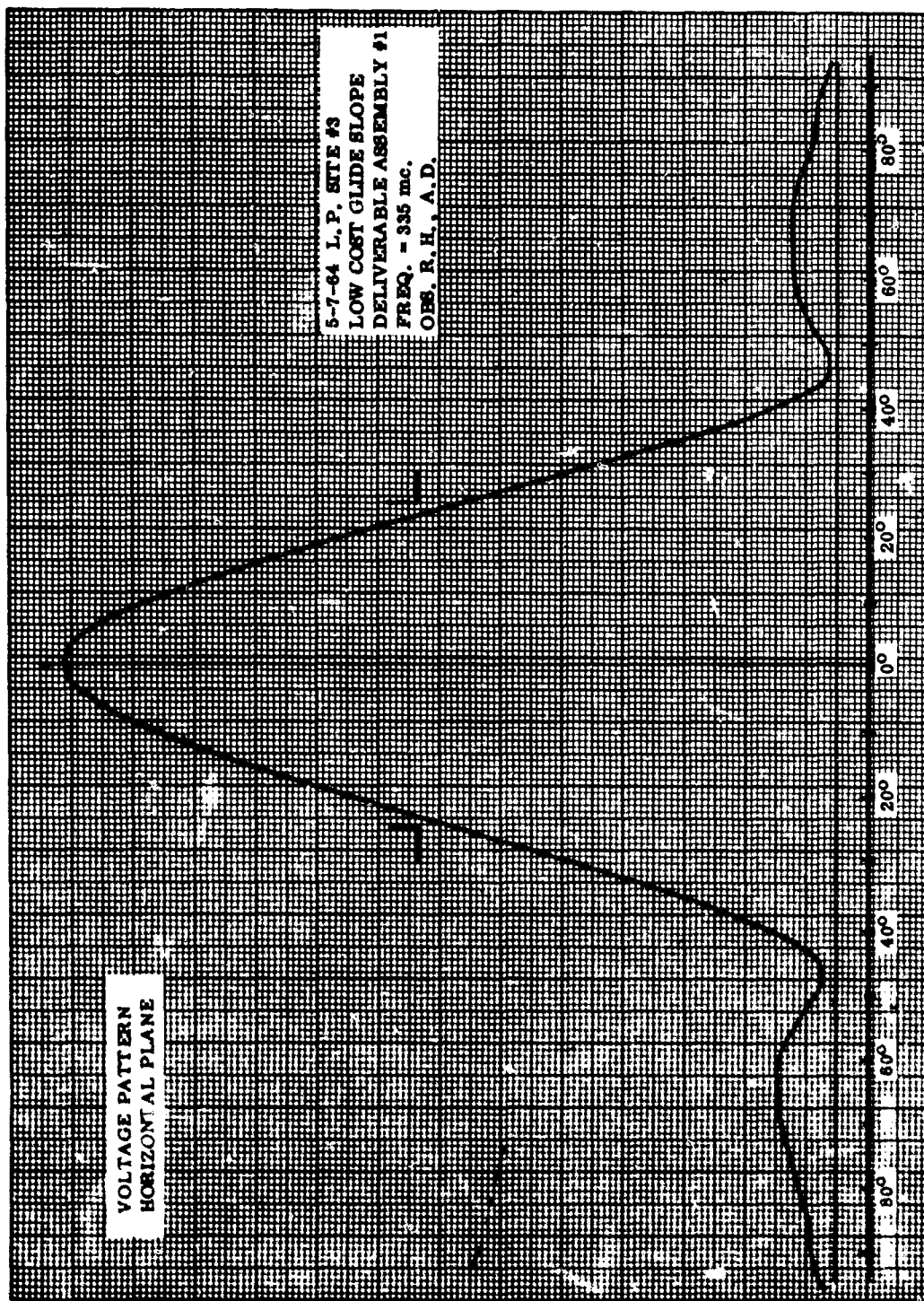

Figure 3. Glide Slope Antenna Bay Voltage Pattern Horizontal Plane

and debug a rough breadboard, incorporate changes, temperature test those units or subsystems which are critical to system performance, and finally construct and test deliverable units. Wherever possible, modular units such as plug-in power supplies, plug-in relays, etc. were employed to facilitate repairs. The following subsections contain pertinent information on the various units contained in the cabinet.

TABLE II - GLIDE SLOPE MONITOR ANTENNA TEST RESULTS

| Assembly Number | Frequency | VSWR at 50 ohms |
|-----------------|-----------|-----------------|
| 1 | 329 mc | 1.10 |
| | 332 mc | 1.04 |
| | 335 mc | 1.05 |
| 2 | 329 mc | 1.11 |
| | 332 mc | 1.04 |
| | 335 mc | 1.05 |
| 3 | 329 mc | 1.18 |
| | 332 mc | 1.01 |
| | 335 mc | 1.00 |
| 4 | 329 mc | 1.17 |
| | 332 mc | 1.06 |
| | 335 mc | 1.03 |

5-20-64 L. P. Site #3

Obs. R. H., A. D.

(3) Transmitter Unit

A cavity similar to that employed in the present FAA-TUS glide slope transmitters was employed to multiply and amplify the exciter output to the proper frequency and power level necessary to drive the modulation unit. The original premise was to employ a 4CX250B tube in place of the 4X150A's for which the cavity was originally designed. During routine tests of the transmitter two problems were encountered with the 4CX250B tubes. The first involved the

ability to tune over the entire frequency band. An apparent increase in output capacity prevented tuning of either the tripler or power amplifier at the high frequency (335 mc/s) end of the band. This problem was resolved by the use of spoilers in each cavity section to reduce the effective inductance and permit the tuning capacitors to control the circuit resonance. The second and more severe problem was an apparent regeneration in the power amplifier after passing through maximum power output and continuing to decrease the tuning capacity. An initial investigation indicated that this condition was probably associated with screen bypass capacity. Therefore, extensive changes were made in the screen bypass capacity and data taken to determine any noticeable change. Over a wide range of capacities there was no appreciable change. The plate current would continue to climb after passing maximum power output and finally reach a peak value at which point it would suddenly snap back to a quiescent value at which it would remain with further decreases in capacity. The maximum value of current peaks varied with different tubes.

Substitution of new 4X150A's did not exhibit this phenomena, nor did they require the additional spoiler plates in the cavities. Therefore, since during normal operation the 4X150A's are operating well within their ratings it was decided to discontinue further efforts at employing the 4CX250B's.

- (a) The frequency versus temperature characteristics of the glide slope exciter subunit were observed by counting the output frequency on a Hewlett-Packard Model 524B counter. The results are shown in the curve in figure 4. The crystal used in this test was $27.6737 \pm .002$ mc resulting in a nominal exciter output frequency of 110.6948 mc nominally. Over the temperature range of -20 to +70 degrees centigrade the frequency remained within the limit of ± 0.005 percent.
- (b) The output power stability was recorded concurrently with the above frequency measurements. The tuning was peaked at room temperature and was not changed throughout the temperature cycle. This power stability data appears in figure 5.

In the above tests the last two output stages were operated at 26 vdc. When the exciter was married to the transmitter unit, the required input was approximately 2 watts in order to drive the transmitter to maximum power output. This afforded the opportunity to replace the original 2N2876 driver and output transistors with 2N2950 transistors at a considerable cost savings with no decrease in reliability. The final output was at least 2.2 watts over the temperature range which is more than sufficient to drive the transmitter unit to its required power output.

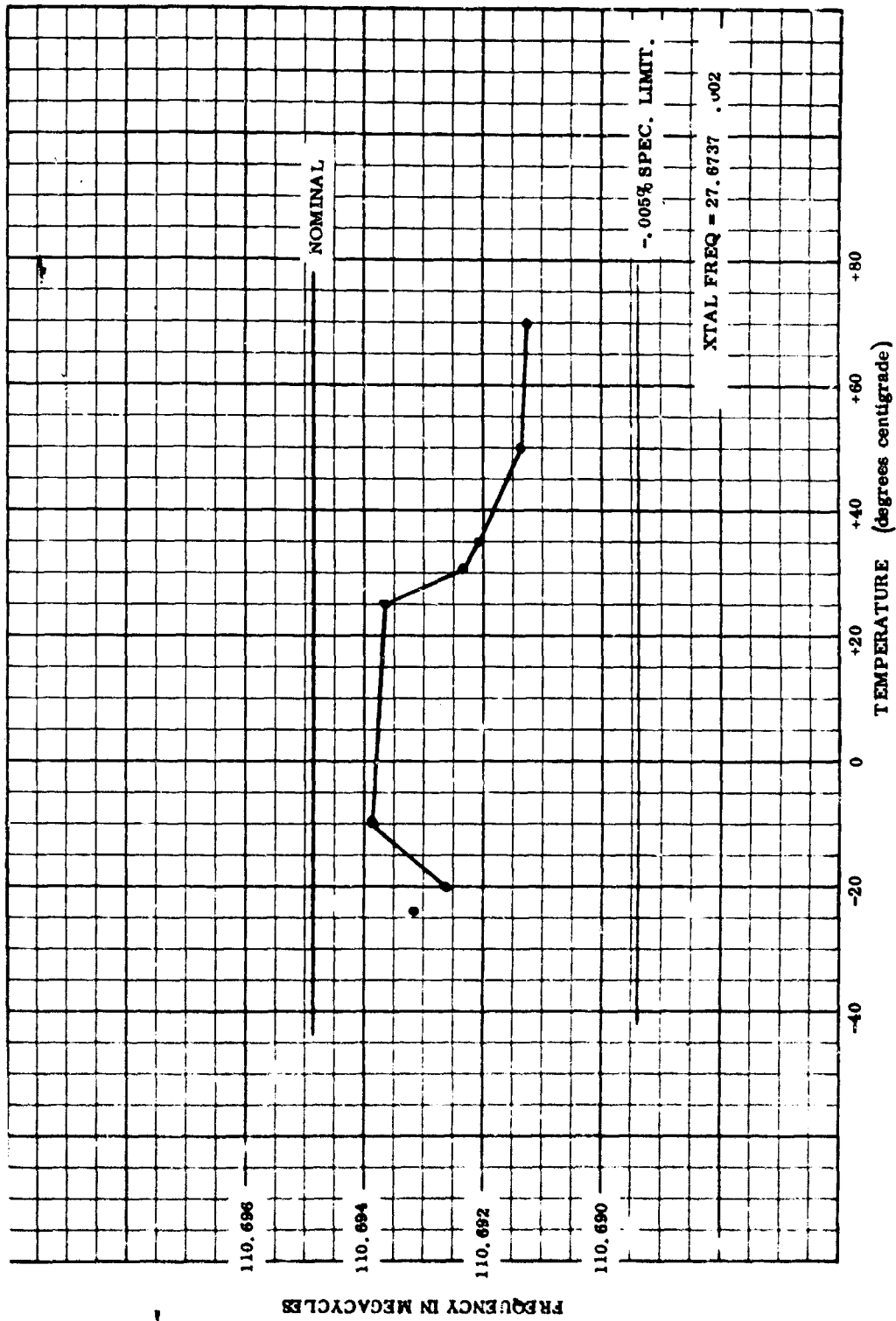

Figure 4. Glide Slope Exciter Output Frequency vs Temperature

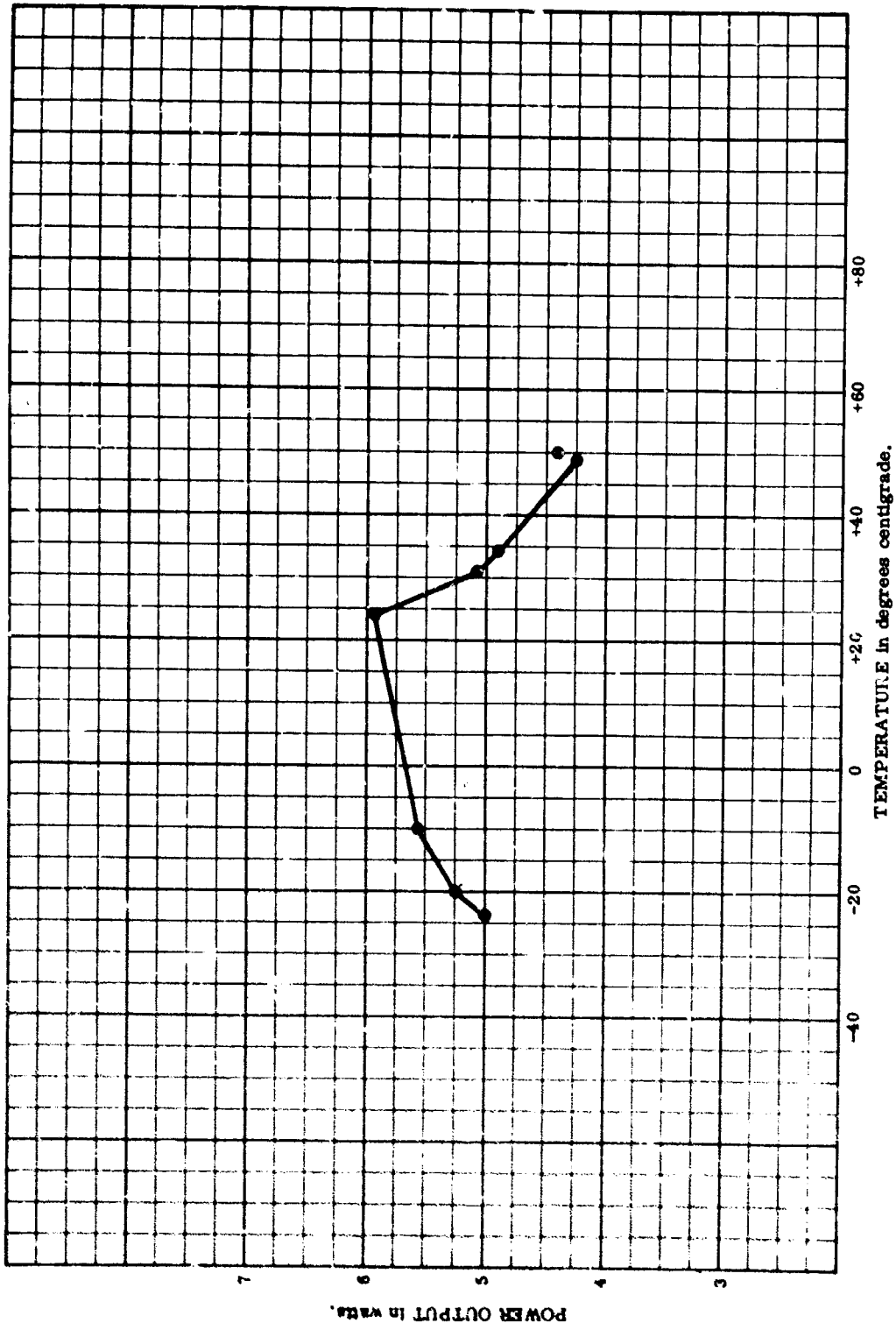

Figure 5. Glide Slope Exciter Power vs Temperature

The prototype unit was reduced only slightly in size from the breadboard model in order to maintain functional layout, ease of construction, and good serviceability.

Most of the above tests were performed at the center frequency of the glide slope band. All the above parameters were checked at frequencies over the entire band with no noticeable change in results. Changing crystals in the oscillator circuit required only slight tuning to optimize output of the exciter.

It was decided to use a pigtail type crystal in the frequency-determining crystal in the exciter to insure good contact and keep capacitance at a minimum. In the field, crystal changes will be infrequent and the amount of time required to remove the exciter subunit and replace a crystal is minimal.

(4) Modulation Control Unit

The sideband generator is the major critical item of this chassis. A constant impedance unit, developed within the ITT system, was procured to serve this function. This generator had undergone considerable evolution and the model obtained was from a production run employed in glide slope equipments produced by STC, Canada, for the Canadian DOT. Extensive testing by STC indicated that this model meets or exceeds applicable performance requirements covered by standard FAA specifications. With the unit properly tuned to the operating frequency, the maximum static VSWR was less than 1.26 to 1 at any individual point in the modulation cycle when measurements were made at the input of each modulation section. The dynamic VSWR with the unit running at 1800 rrm was less than 1.04 to 1.

The remaining components employed in this unit consists of standard commercial hybrid bridges, T-phasers, modulation motor, detectors and various cables. Since the cable lengths are critical, each individual length was calculated and then cut to within ± 2 degrees of the required length. Also, extra cable was inserted in the carrier section of the distribution network to compensate, both for temperature and frequency, the extra phase shifts involved in generation of the sideband signals before recombination with the CW carrier. Whenever possible cables were cut to be multiples of $1/4$ wavelength at mid-frequency.

(5) Control Unit

Standard commercial components were employed in construction of the control unit. The only breadboard construction involved the tie in between the remote control unit and the start stop status lines. A few minor problems were

encountered when the control unit was incorporated in the system. These were associated with the reset circuitry and were readily resolved by modification of the reset push button switch and modification of the time delay relay to employ the motor shut off switch as part of the time delay circuitry.

(6) Monitor

Considerable breadboard construction and tests were conducted on the circuits associated with the monitor since this unit performs a critical system function and must be made as fail safe as is practically possible. Also the unit must be very stable in order to assure close adherence to alarm criteria. The mechanical construction was designed so that the complete unit consists of a main chassis and two identical subchassis. The main chassis contains the alarm relays, power supplies, reset circuitry, and metering. The identical subchassis contains a stabilized transistor audio amplifier, tone filters, and rectifiers to drive the alarm meter relays. The reset circuit which supplies pulses approximately once each 1-1/3 second, was tested at +55°C to assure that no drastic changes occur as a result of capacitor leakage. The original breadboard circuit components had a reset time constant of 1.40 seconds at +26°C which changed to 1.47 seconds at +55°C. Since the time is not critical this slight difference is insignificant. Slight revisions were made in this circuit to change the time constant slightly to 1.3 seconds.

(7) RF Level Monitor

The RF level monitor alarm meter, in the main chassis, is driven from a separate antenna plus a detector circuit located in front of the array. Considerable data was accumulated to determine the effects of different crystals, levels and temperature. Tables III and IV, and paragraphs (a) through (c) contain representative data which indicates that this circuit should perform satisfactorily in system operation.

TABLE III - MINIMUM SENSITIVITY FOR 150 ua METER INDICATION
AS A FUNCTION OF DIFFERENT 1N21B DIODES

| Crystal Number | Sensitivity (dbm) |
|----------------|-------------------|
| A | -10.2 |
| B | -10.2 |
| C | -11.5 |
| D | -10.2 |
| E | -11.5 |

- (a) Variation in 3 db alarm indication as a function of temperature. Nominal sensitivity of -10.1 dbm. This data represents both a cold and hot series of test. Meter was originally set for 150 microamps and level held constant at -10.1 dbm. The plot is shown in figure 6.
- (b) Utilizing shunt resistance to set the initial normal indication of 150 microamperes, data was also accumulated to determine required resistance and variation of alarm reading for power levels from +7 dbm to -10 dbm. This includes the range which would be encountered in the field. This data was accumulated for a crystal which had a maximum sensitivity of -10.1 dbm for a 150 ua meter indication. See figure 7.
- (c) Temperature tests were run on two audio subunits. The conditions were as follows:
- (1) Carrier signal modulated 40 percent by each signal employed. Variable ddm generator used to vary signal.
 - (2) Cross pointer adjusted for 100 microamps equal to 0.050 ddm. Calibration pots in chamber.

A table giving the test data appears in table IV and a curve of flag and crosspointer indications is shown in figure 8.

TABLE IV - TEST DATA FOR AUDIO SUBUNIT TEMPERATURE TESTS

| Sample 1 | Time | Temp °C | Flag 0-ddm ua | Cross Pointer 0-ddm ua | Cross Pointer 0.05 ddm ua | 90 cps Filter vrms | 150 cps Filter vrms | Output Trans vac p-p |
|----------|-------|------------|---------------------|---------------------------------|------------------------------------|--------------------------|---------------------------|-------------------------------|
| 4/23/64 | 9:35 | +27 | 200 | 0 | 100 | 8.2 | 8.2 | 190 |
| | 11:30 | +68 | 200 | 2-90 cps | 101 | 8.1 | 8.1 | 196 |
| | 1:00 | +52 | 200 | 1-90 cps | 101 | 8.1 | 8.1 | 193.5 |
| | 2:45 | +41 | 200 | 1-150 cps | 104 | 8.2 | 8.2 | 192 |
| | 4:35 | +38 | 201 | 1-150 cps | 101 | 8.2 | 8.2 | 192 |
| 4/24/64 | 8:30 | +24 | 200 | 0 | 100 | 8.2 | 8.2 | 190 |
| Sample 2 | Time | Temp °C | Flag 0-ddm ua | Cross Pointer 0-ddm ua | Cross Pointer 0.05 ddm ua | 90 cps Filter vrms | 150 cps Filter vrms | Output Trans vac p-p |
| 4/23/64 | 9:35 | +27 | 200 | 0 | 100 | 8.3 | 8.4 | 194 |
| | 11:30 | +68 | 203 | 1-90 cps | 100 | 8.25 | 8.4 | 200 |
| | 1:00 | +52 | 202 | 1-90 cps | 100 | 8.2 | 8.3 | 198 |
| | 2:45 | +41 | 202 | 1-90 cps | 102 | 8.3 | 8.4 | 196 |
| | 4:35 | +38 | 202 | 1-90 cps | 102 | 8.3 | 8.4 | 196 |
| 4/24/64 | 8:30 | +24 | 200 | 0 | 100 | 8.25 | 8.4 | 194 |

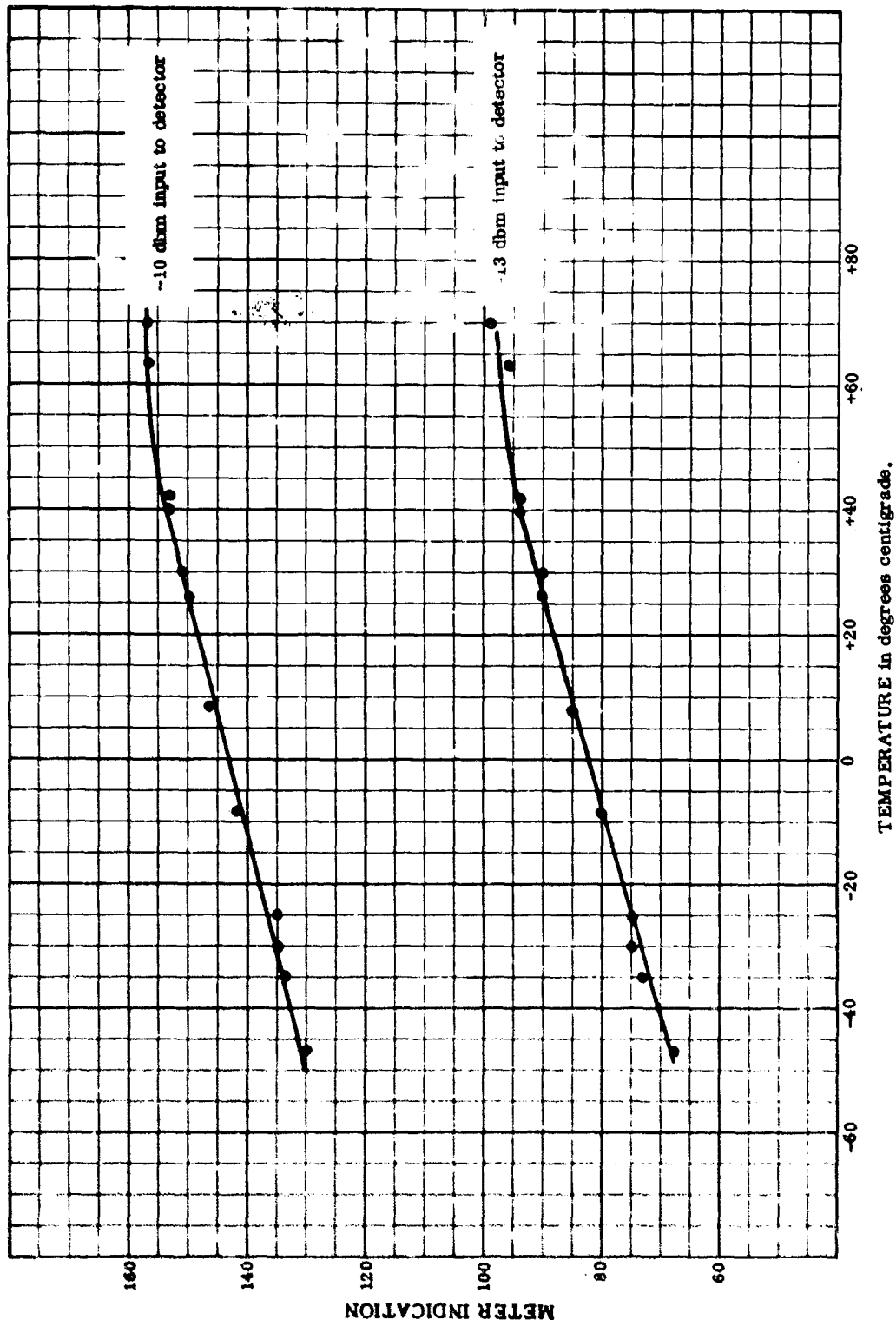

Figure 6. Glide Slope RF Level Indication vs Temperature

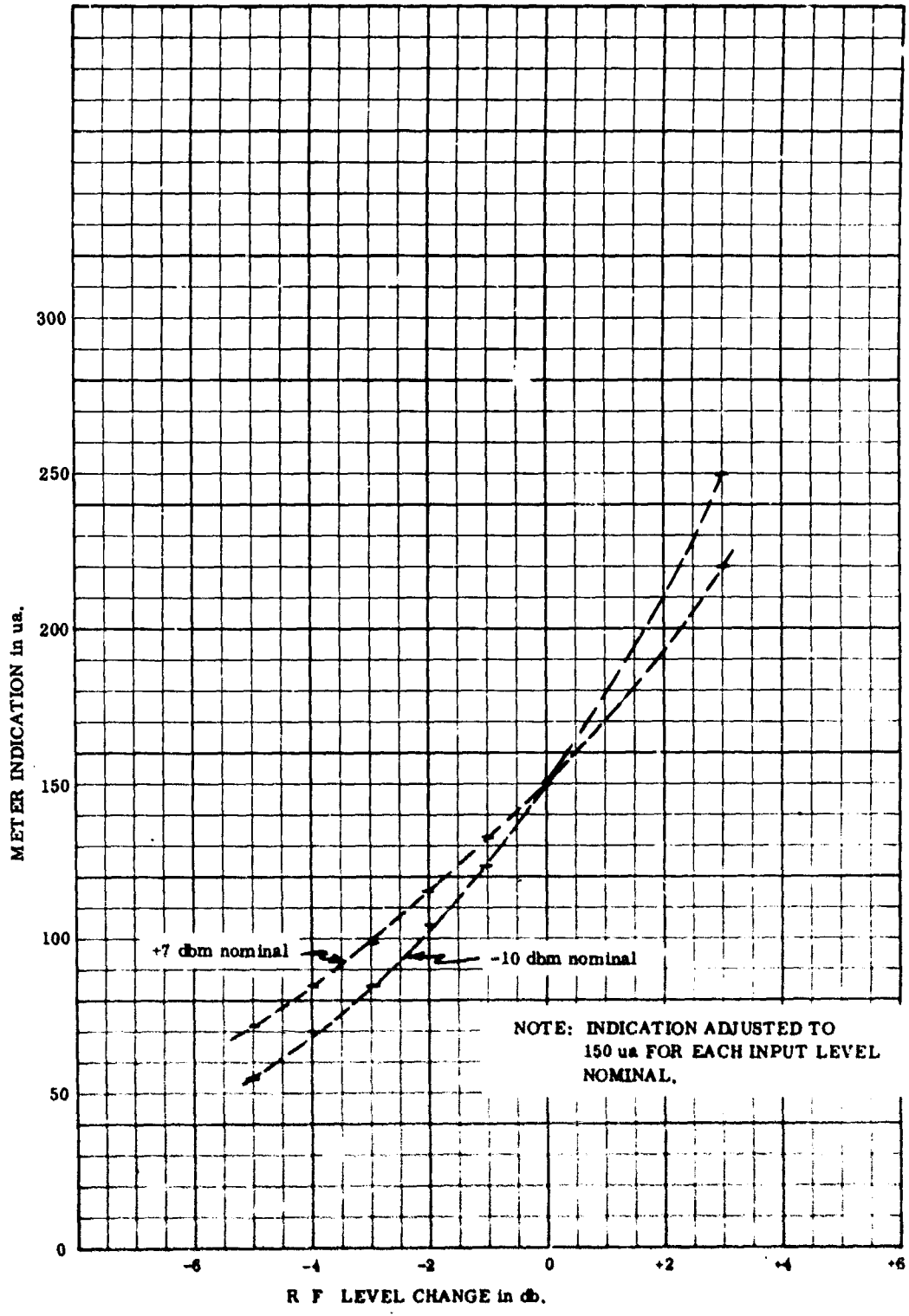

Figure 7. Glide Slope Meter Indication vs RF Level Change

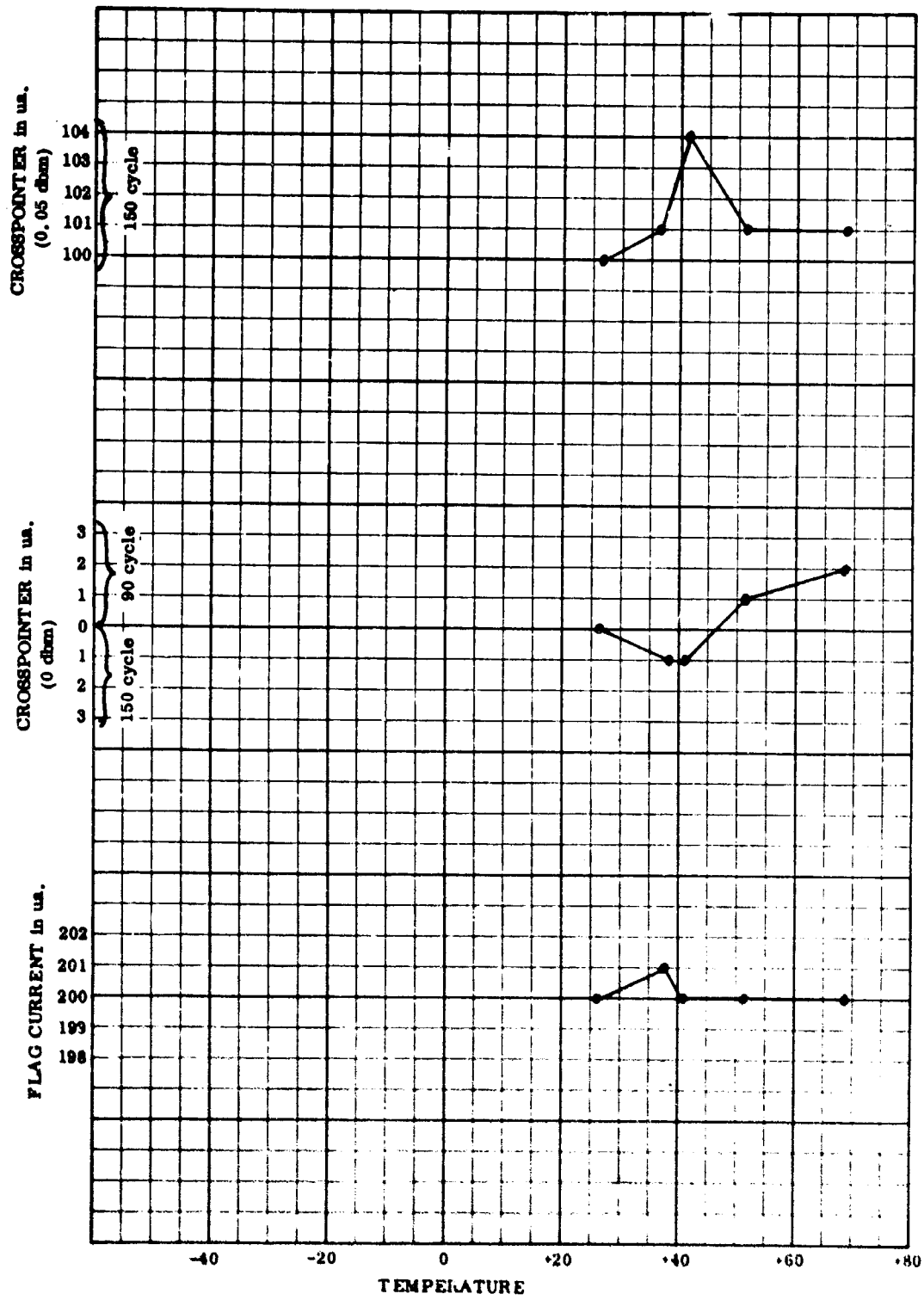

Figure 8. Glide Slope Monitor Stability vs Temperature

(8) Audio Subunits

Considerable breadboard construction and preliminary testing was accomplished on the subunits during construction. Since the units employ a great amount of feedback for stabilization, problems were encountered with self oscillation when the normal low-impedance driving source was removed. This situation was undesirable, therefore, modifications were made in the input circuitry to eliminate this condition. In addition the nominal closed loop gain of the amplifier is greater than that necessary in order to work with the audio level from the field monitor. This results from the requirement for linear detection in the field monitor and as a by product a fairly high audio signal level. Therefore, additional stabilized series impedance is utilized to drop the unit signal level.

Temperature tests were conducted on two audio subunits to establish data indicative of the compensation necessary for variation in filter attenuation and other components variations which of necessity are outside the feedback loop. The results of these tests were utilized to design a theoretical thermistor compensation network. The network was incorporated in two audio subunits which were subjected to high temperature tests to prove the design. The following data indicates the results of these tests.

A review and analysis of the temperature data indicates that before compensation the units experienced a change in output of approximately 3.5 to 4 percent at both the high and low temperature extremes. The output decreased at high temperatures and increased at low temperatures. The majority of this change is apparently the result of change of filter copper losses. The flag current readings are representative of the change which is confirmed by cross-pointer readings corrected for zero shift. Also, it should be noted that the zero center shift apparent during many of the tests was negligible.

The tests after compensation indicate that the average change in amplifier output was reduced to less than one percent as noted by flag current readings. Also, the cross pointer setting for a change of 0.050 ddm was held close to the original setting of 100 microamps. The net result of the compensation was an improvement in the alarm stability over the temperature range, once in particular with respect to the flag current indication used as an indicator of percent modulation. The stability of this unit in conjunction with the stability of the field monitor output is more than adequate to satisfy ICAO Category I requirements.

(9) Power Supply

The power supply employed is a modified version of a commercial unit manufactured by Utronics Incorporated. Basically the modifications consisted of removing front panel meters and revising the control circuitry. Variations in output voltage from 500 to 1000 volts, with a capacity of 500 milliamperes, are available by potentiometer controls on the rear of the chassis. The normal voltage setting is 800 vdc. Regulation is provided for variation in both line voltage and load.

The unit performed satisfactorily when incorporated in the system with the exception of its own time delay relay. Therefore, modifications were incorporated to utilize the time delay incorporated in the system control unit. Although the unit performed satisfactorily the number of components employed undoubtedly could contribute to a decrease in the system MTBF. Therefore, a simplified version will be investigated for use in future procurements.

(10) System Data

The completed shelter was installed at the company's Lincoln Park, New Jersey, test facility in order to check out the complete system. Sufficient cursory ground measurements and flight checks (utilizing an FAA aircraft) were made to insure that the system would function properly when installed. A typical set of data taken by means of a portable receiver is indicated in Table V.

A review of the data indicates an area where further explanation is required. That is, the power output of seven watts is low since the specification limit requires 10 watts. However, this is attributable to two sources, (1) the high voltage during the test was slightly low, and (2) the wattmeter employed was later found to be defective. Subsequent test revealed that a power output of approximately 15 watts is available with proper power supply voltage. Also, since a constant impedance modulator is employed the power output can be increased above 15 watts by tighter coupling.

(11) Glide Slope Tower Unit TU-8X/2

Simplified breadboard tests were made on the alarm indicator and start-stop signal generating circuits to determine voltage requirements. Sufficient margin has been provided so that the unit will operate satisfactory with the equivalent of a 1000 ohms series attenuation between the remote control point and glide slope shelter. Additional circuitry was added to provide auxiliary functions such as an audible alarm with turn off switch.

TABLE V - TEST DATA FOR GROUND MEASUREMENTS AND FLIGHT CHECKS

| | | |
|-----|---------------------------|---|
| (a) | Frequency: | 332.3 mc/s |
| (b) | Modulation Unit | Scale Readings |
| | Carrier Sideband Phaser | 2.8 |
| | Sideband Phaser | 4.25 |
| | Percent Modulation | 45.5 |
| | Modulation Ratio | 45.0 |
| (c) | Transmitter Settings | |
| | (1) Meter: | |
| | OSC | 65 |
| | First Dblr | 63 |
| | Second Dblr | 82 |
| | First Amp | 79 |
| | Second Amp | 112 |
| | Trip Grid | 90 |
| | P. A. Grid | 120 |
| | R. F. Level | 70 |
| | 13 V | 135 |
| | 800 V | 63 |
| | (2) Trip Dial Setting | 77.5 |
| | Trip Plate Current | 108 ma |
| | P. A. Dial Setting | 39.7 |
| | P. A. Plate Current | 148 ma |
| (d) | Power Output | 7 watts |
| (e) | Data | |
| | <u>Path Width Control</u> | <u>Width as a Function of Angle θ</u> |
| | 10 | - |
| | 15 | 0.810 |
| | 20 | 0.430 |
| | 25 | 0.310 |
| | 30 | 0.220 |
| | 35 | 0.150 |

(12) Glide Slope Field Detector TU-8X/1

The glide slope field detector is a transistorized dual channel super-heterodyne receiver. It has an extremely stiff agc characteristic thus enabling the detected audio outputs of the unit to give a direct indication of the percent

modulation of the RF signal present at the input terminals of the receivers. A block diagram of the unit appears in figure 1.

The local oscillator was designed to give dual outputs of approximately 60 milliwatts each into the resistive decoupling network, located in the collector circuits of both output stages. The dual output stages are required in order to isolate the two receiver channels.

The entire field detector unit was designed for operation over an ambient temperature range of -40°C to $+70^{\circ}\text{C}$ or -40°F to $+158^{\circ}\text{F}$. The local oscillator outputs into the resistive attenuator were tested over this range and were sufficiently stable to allow satisfactory system performance. The data on this temperature run appears in figure 9.

The local oscillator output is mixed with the input signal in a coaxial hybrid bridge; the balanced mixer diodes are fed from the outputs of this bridge. The use of a hybrid bridge for combining the signals serves to isolate the local oscillator from the antenna and thus precludes undesirable L.O. radiation. The bridges used are the same as those utilized in the phasing circuits of the twin antenna width monitor system incorporated in the field detector unit. Data taken on the phasing bridges using ideal loads is plotted in figure 10 and indicates the rejection capability of the units when loaded with equal impedances.

The initial design goal for the IF amplifier was to provide sufficient gain so that a buffered output of 2 V rms would be achieved with input signal levels of 500 μV rms to 20 millivolts rms. In the course of the development it was found that the agc control circuits in the emitters of the first two IF amplifiers had a tendency to distort the modulation at high levels of input signal. Accordingly, the gain of the IF amplifier was increased and 30 db pads incorporated on the antenna outputs to drop the normal input level.

A design simplification may be possible in future IF units which would change the present agc control circuits to a series diode attenuator, thus eliminating the possibility of envelope distortion, allowing reduction in IF gain, and elimination of the 30 db series attenuator.

The local oscillator injection level is sufficient to bring the mixer diodes into a conducting region where linear mixing is achieved. A test of the IF amplifier output versus L.O. power was run and the results appear in figure 11. The data indicates a wide range of L.O. power variation without appreciable effect on signal output.

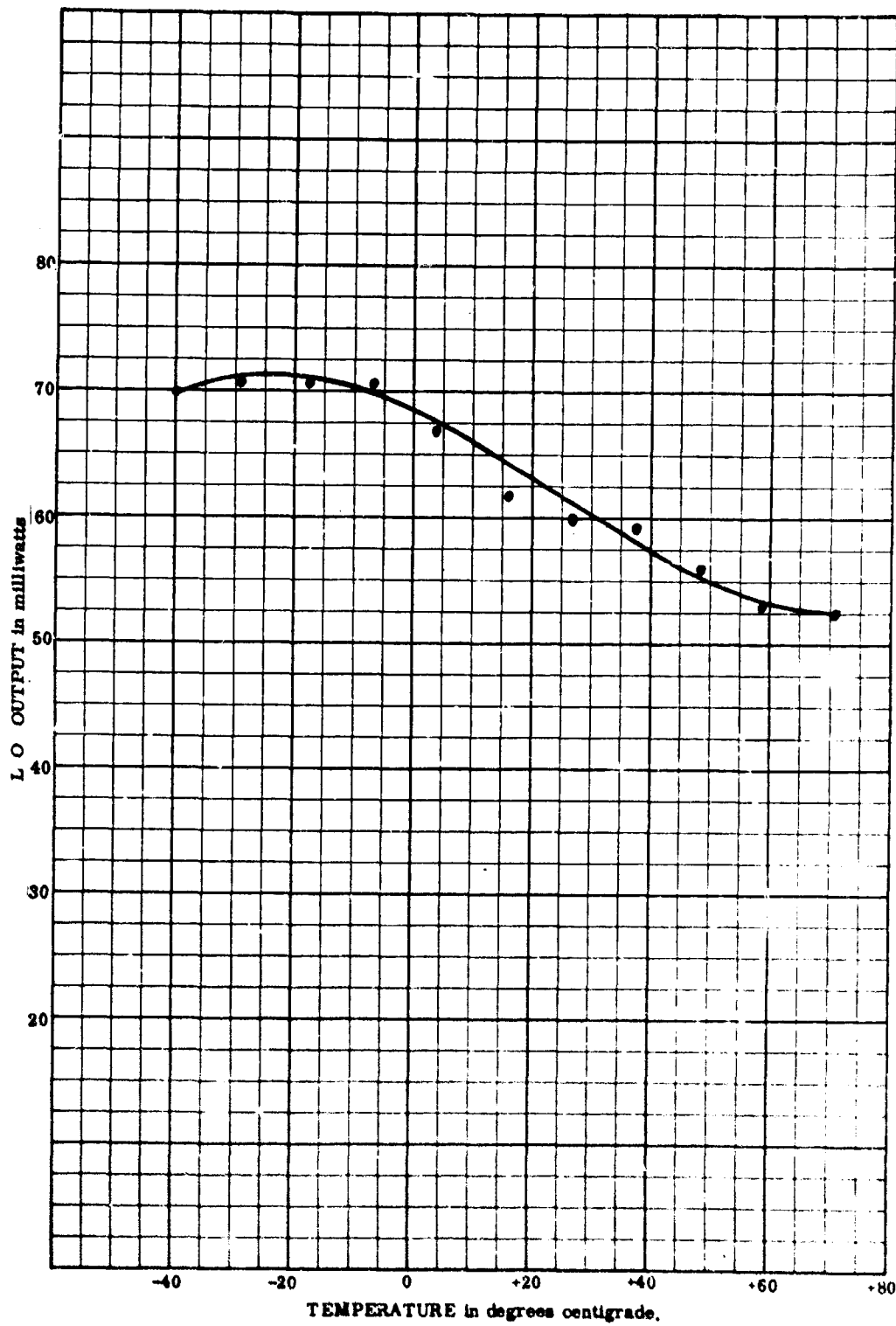

Figure 9. Glide Slope Field Detector LO vs Temperature

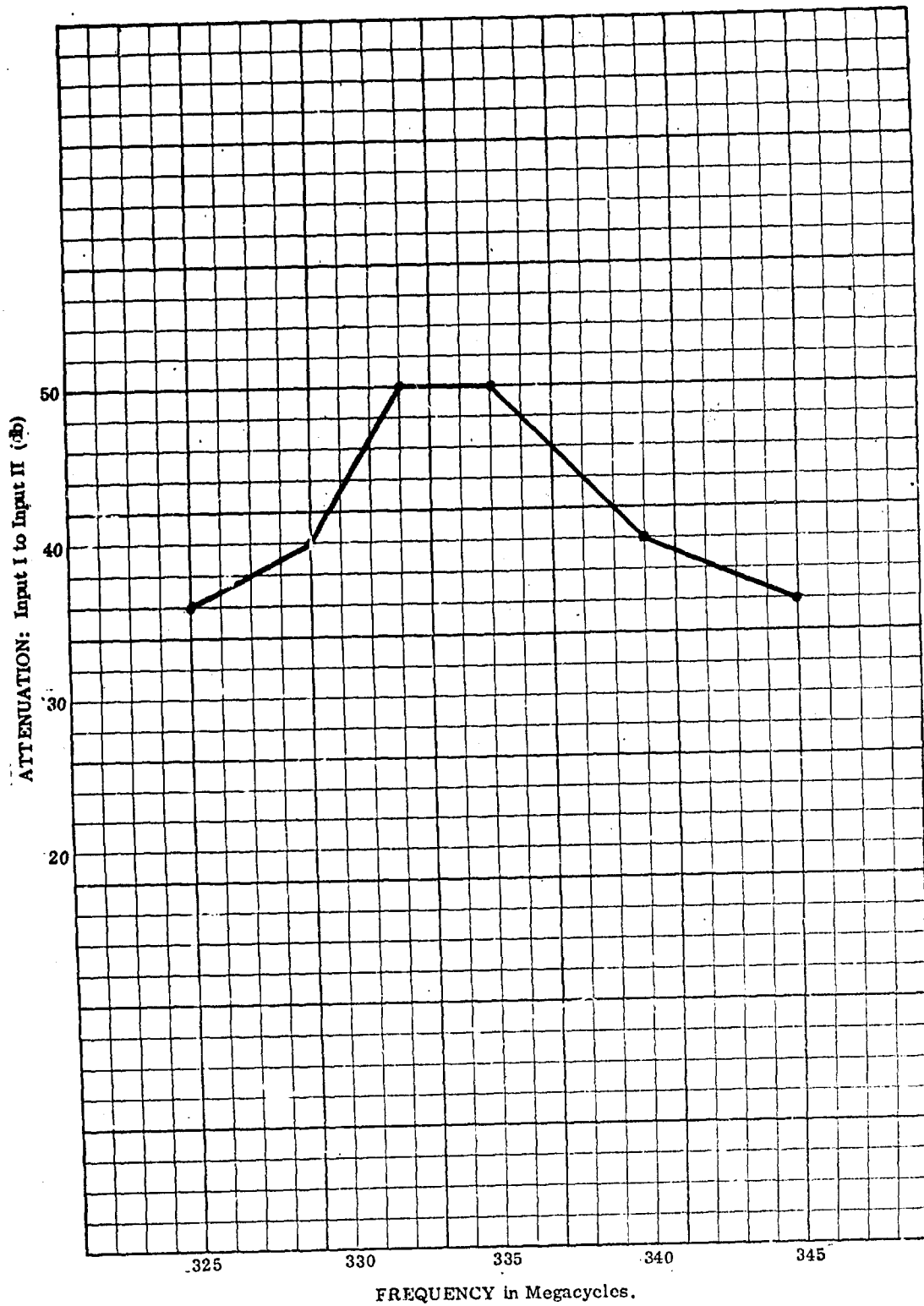

Figure 10. Glide Slope Hybrid Input Isolation

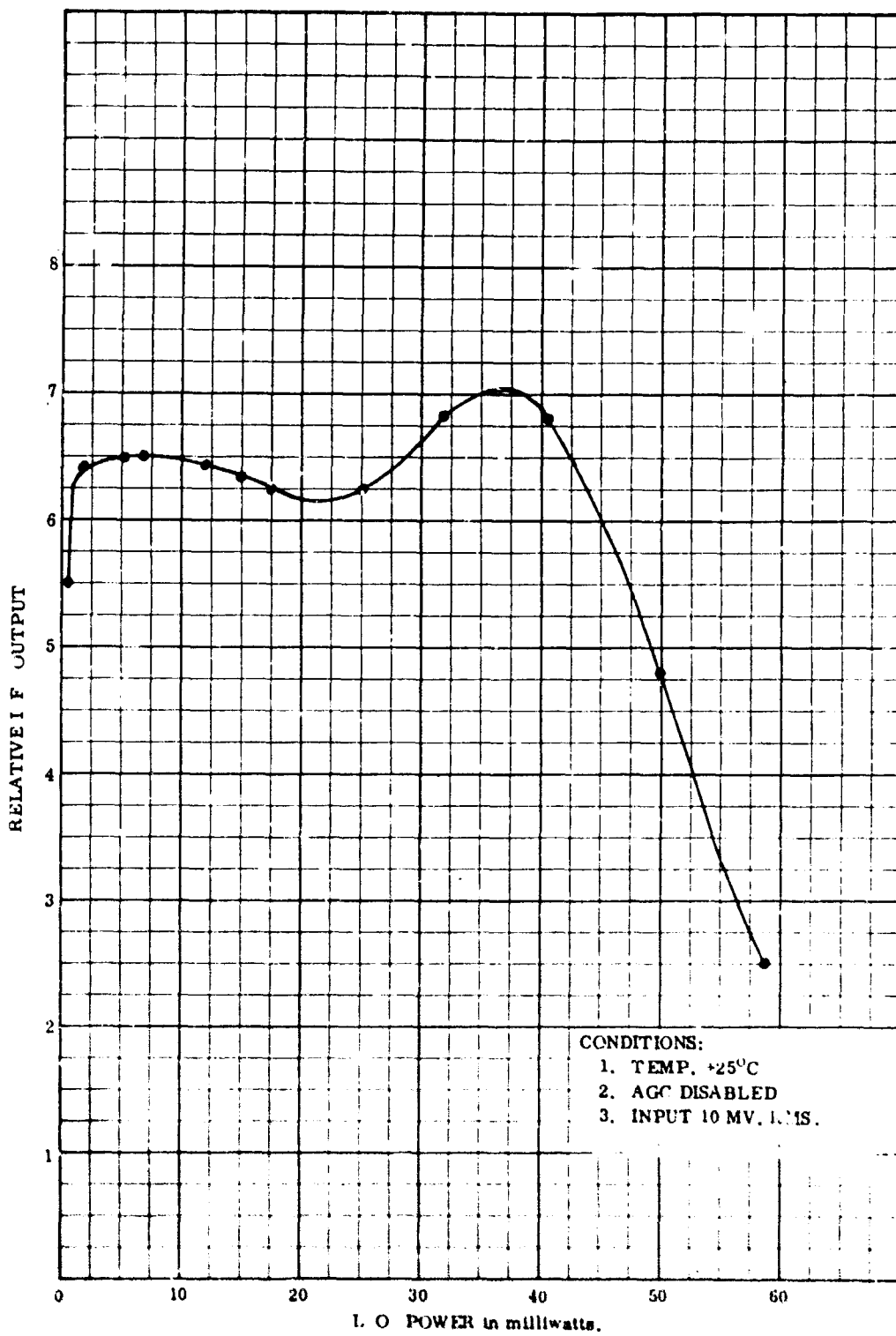

Figure 11. Glide Slope IF Output vs LO Power

The entire field detector system was tested for operation over a range of ambient temperatures from -40°C to $+70^{\circ}\text{C}$. These temperature tests were run at three input signal frequencies and three input signal levels. The three signal frequencies chosen represent signals near the middle of the IF band and at both extremes of the IF band beyond the bandwidth used in the system. The nominal center frequency of the IF amplifier is 8.8 mc and the end points of the band are nominally 7.9 and 9.7 mc. Thus the extremes were chosen to test the field detector under more severe conditions than normally would be encountered in service.

The normal input signal level of -45 dbm was used at each test frequency. In addition runs were taken at the upper end of the IF band with variations in input signal level which represented the full design range of age circuits.

The results of these temperature tests indicate that the field detector output over a temperature range of -40°C to $+70^{\circ}\text{C}$ will be proportional to the percent modulation of the input signal to an accuracy of $\pm 3\%$ of nominal setting. The temperature data taken on the field detector appears in figures 12 and 13.

MARKER BEACON SYSTEM ENGINEERING DATA

(1) Antenna System

The marker beacon antenna was designed to produce a pattern which would more evenly distribute the radiated energy throughout the sector in which the aircraft is to receive an indication. By doing this, it is possible to reduce the power from the transmitter and still obtain ICAO specified operation.

Previous marker beacon antenna designs concentrated the energy into a fairly narrow beam, directed vertically.

Using the aircraft altitude when over the marker antenna, and the aircraft speed and length of time of indication as specified in ICAO Annex 10, it is seen that the aircraft must receive a visual indication while in a sector of approximately $\pm 40^{\circ}$ from the vertical for the outer marker and approximately $\pm 65^{\circ}$ from the vertical for the middle marker. By widening the beam and directing more energy away from the vertical, less transmitter power is required to obtain threshold signal level at the edges of these sectors while still maintaining adequate signal level throughout the sector. The antenna system used consists of two half-wave horizontal dipoles spaced 120° apart vertically and excited in quadrature with equal amplitudes.

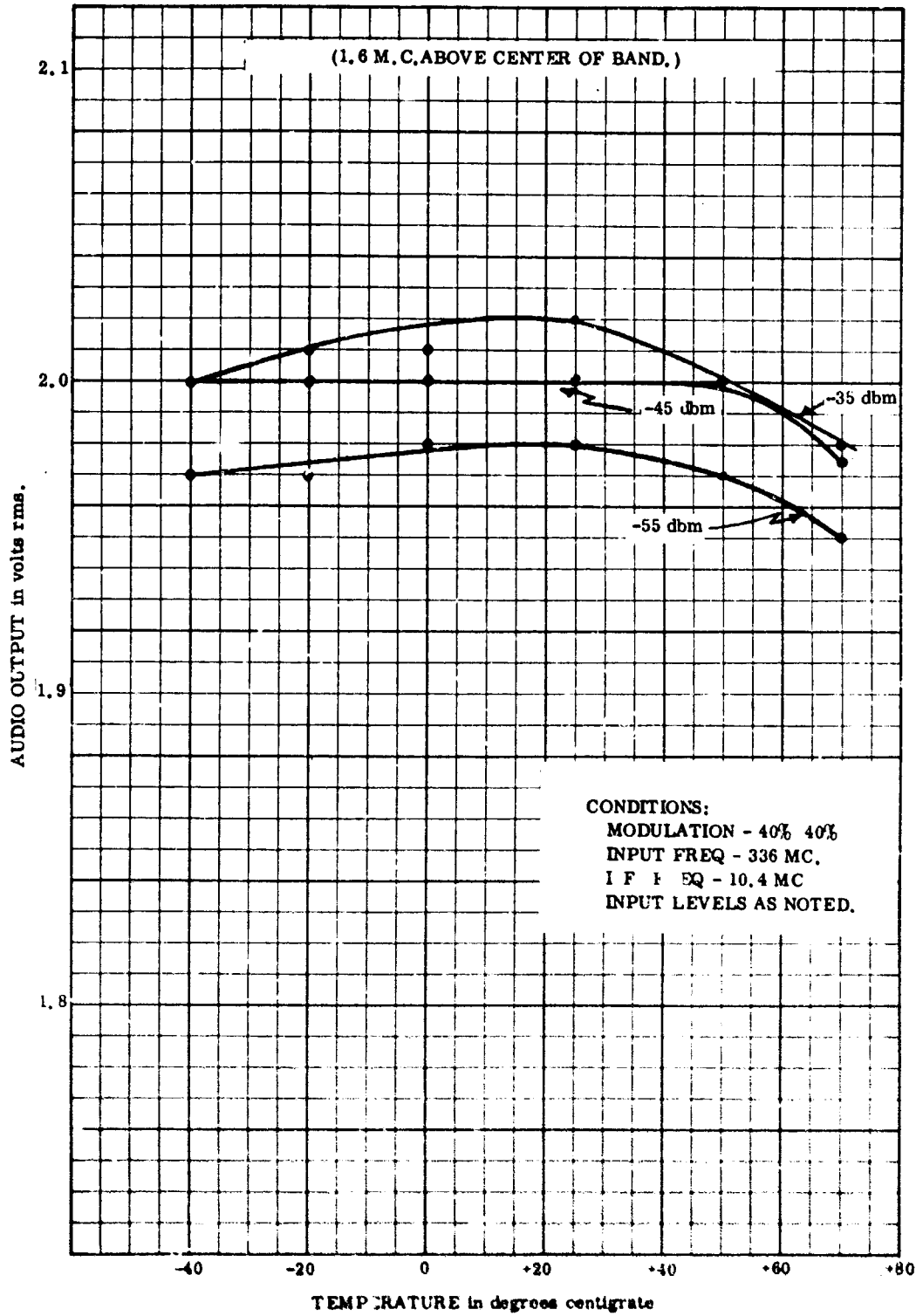

Figure 12. Glide Slope IF Output vs Temperature

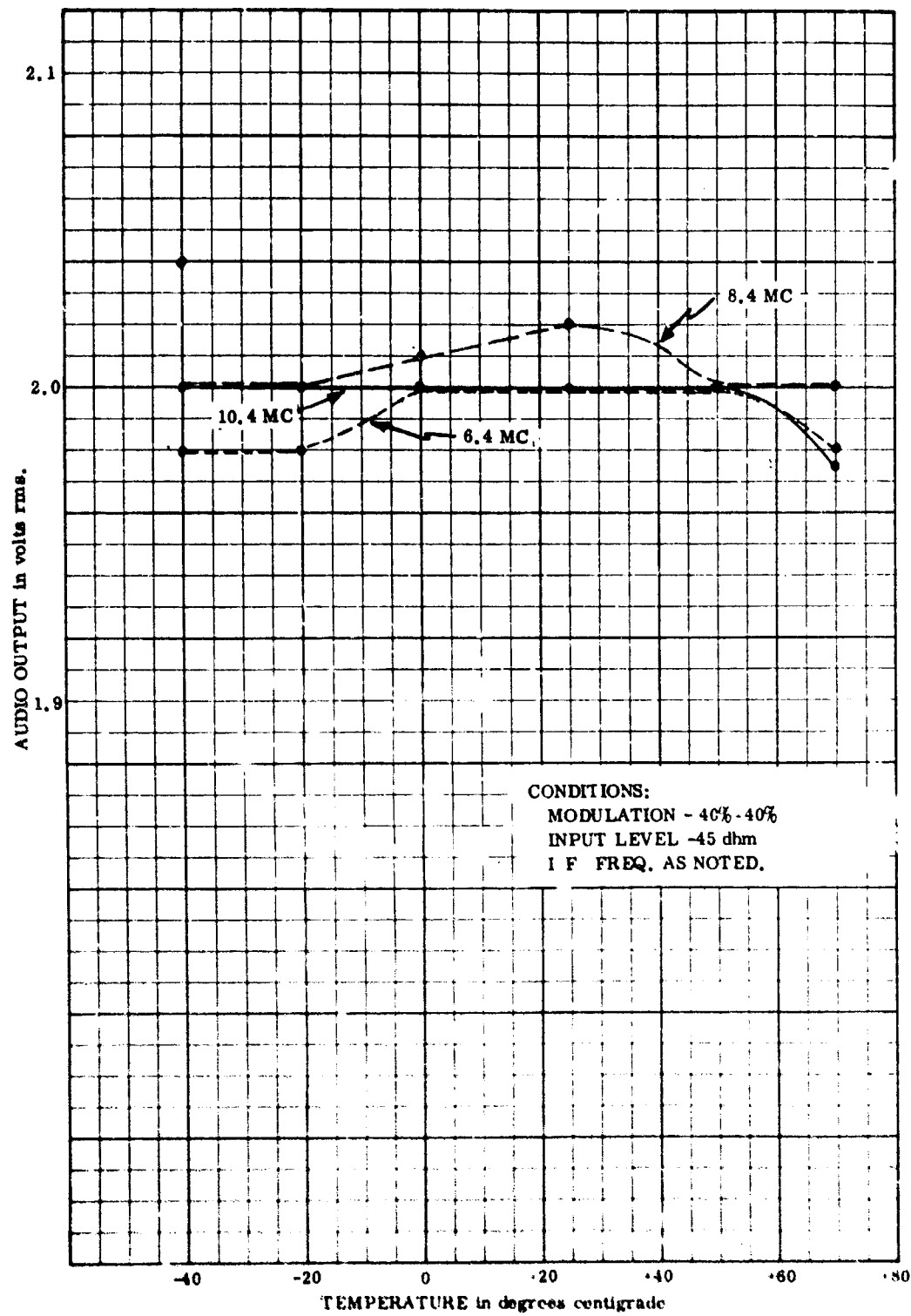

Figure 13. Slide Slope IF Output vs Temperature

Measurements made on the marker beacon antennas included vertical patterns both in the plane perpendicular to the lines of the dipoles (cross-course), and in the plane containing the dipoles (on-course), and input VSWR. The pattern measurement equipment and techniques used were comparable to those used in the glide slope antenna measurements (see page 12), and differed only when the difference in RF frequencies required a change. As before, there is both a receiver noise level and an absolute zero level plotted.

The cross-course patterns of the marker beacon antenna are found in figure 14. The center of the horizontal scale corresponds to the signal radiated on the horizon, the right extreme corresponds to the signal radiated straight up, and the left extreme corresponds to the signal radiated straight down, when the antenna is erected in operating position.

In the cross-course plane the elements appear as point sources, therefore these plots demonstrate the effect of the element spacing and excitation (array factors) upon the radiated pattern. Referring to these patterns it is seen that most of the energy is directed above the horizon with particularly large and fairly constant signal level above 25° . The maximum of the curve is at 48° above the horizon while the minimum occurs at 48° below the horizon thereby demonstrating the quadrature relationship between element excitations. The depth of the null demonstrates that the excitations are approximately equal in amplitude.

The on-course patterns of a marker beacon antenna is found in figure 15. In this plane the pattern is the array factor (cross-course) pattern multiplied by the dipole factor. This has the effect of producing an extremely deep null on the horizon. (Theoretically this should reach the receiver noise level. However, for these measurements the receiving antenna was not sufficiently far away to see the ends of both dipoles simultaneously.) The dipole factor also has the effect of decreasing the beam width in the on-course plane.

The input VSWR in both cases was less than 1.2:1 at 50 ohms which provided a satisfactory load on the transmitter.

A monitor stub was also included on the antenna mast. A tapped variable coil was used to tune out the capacitance of this stub and transform the real part of its impedance to 50 ohms. In both cases the VSWR was adjusted to under 2:1 at 50 ohms which was adequate for satisfactory monitor operation.

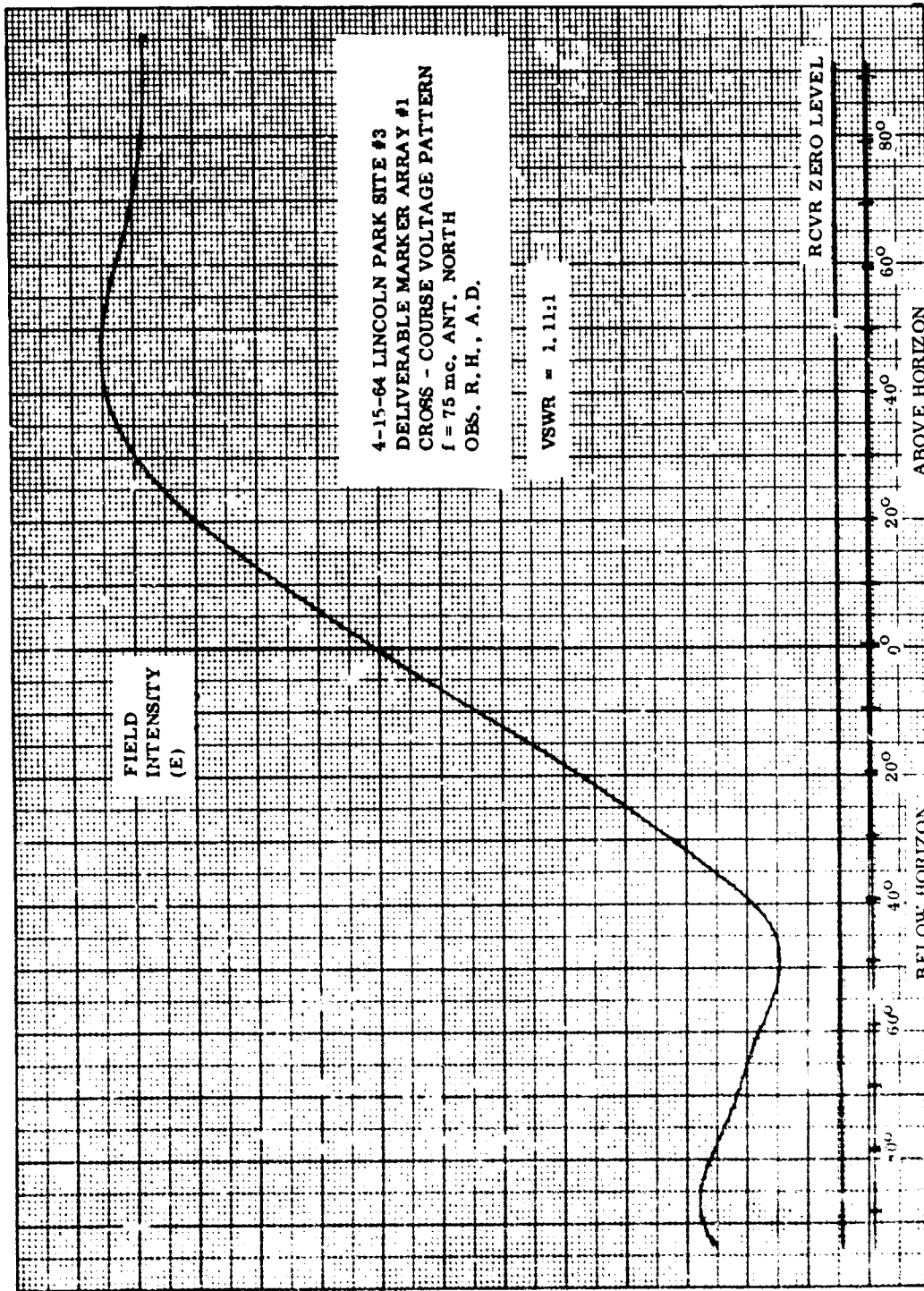

Figure 14. Marker Beacon Antenna Cross-Course Voltage Pattern

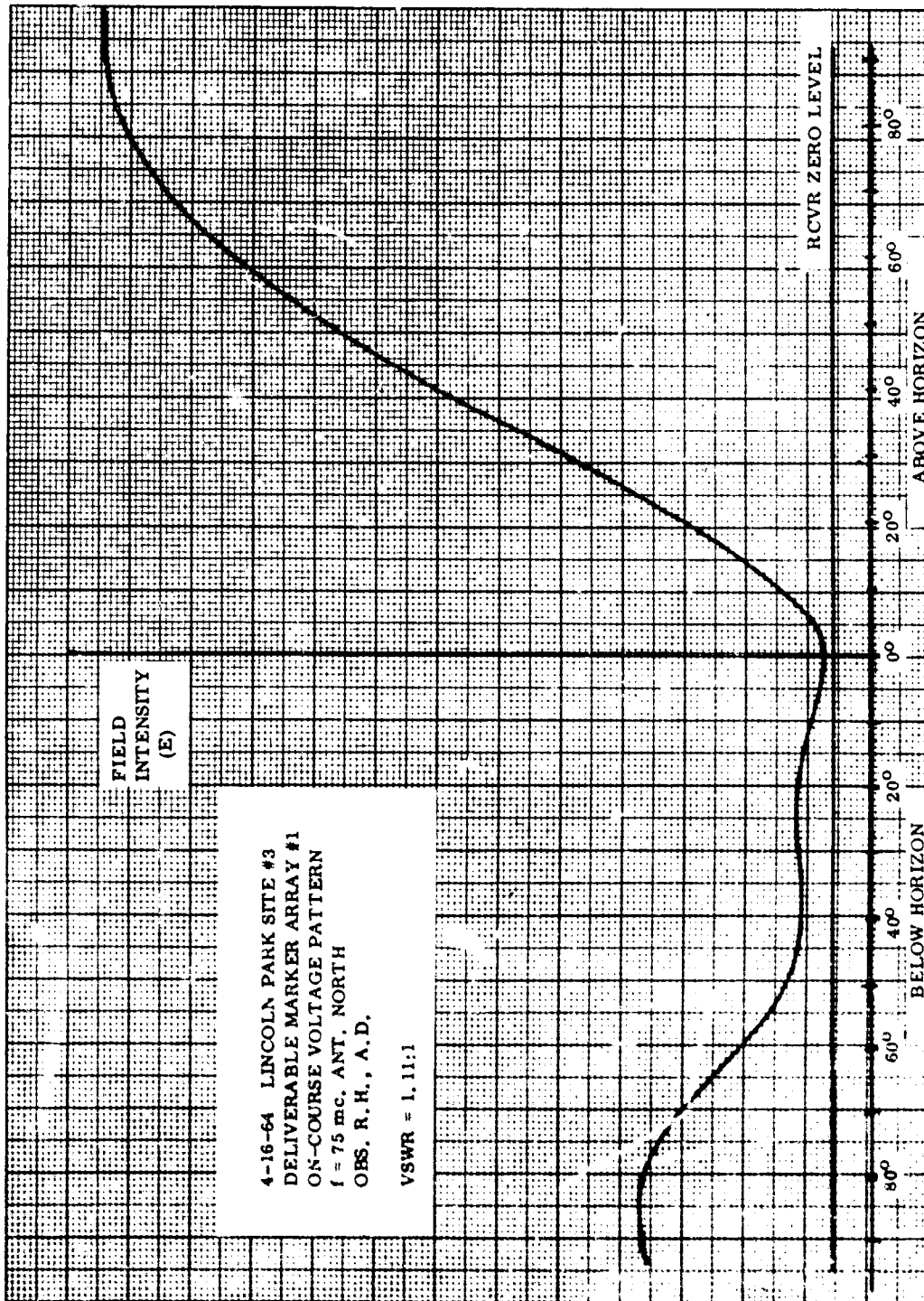

Figure 15. Marker Beacon Antenna On-Course Voltage Pattern

(2) RF and Modulator Unit

At the inception of the I. L. S. system development phase, it was decided to design, fabricate, and test the Glide Slope Exciter subunit prior to design of the Marker Beacon RF Modulator subunit. Several reasons prompted this decision. First, the frequency tolerance specifications were more stringent on the former; therefore, if the frequency stability requirements were met on the glide slope subunit, no difficulty would be encountered on the marker beacon equipment. Second, the frequencies of the oscillators used in both equipments were comparable enough so that designs of one might be applied to the other.

The frequency stability of the glide slope equipment was within the limits specified ($\pm .005\%$) even when checked over the wide temperature ranges targeted for the marker beacon equipment.

The results in figure 16 were obtained during a frequency versus temperature run on the prototype RF modulator chassis of the marker beacon system as observed on a Hewlett-Packard model 524B electronic counter.

The greatest frequency deviation occurred at 70°C and was approximately 1 kc, or 0.0013 percent. At the extreme cold temperature the frequency deviation was in the opposite direction, but slightly less in amplitude. This is within the frequency specifications of $\pm 0.02\%$.

Harmonic distortion as measured on a Hewlett-Packard Harmonic Analyzer model 300A at the secondary of the modulation transformer is tabulated below in Table VI.

TABLE VI - MARKER BEACON HARMONIC DISTORTION VERSUS TEMPERATURE

| Temperature | Percent Distortion | | |
|----------------------------------|--------------------|-----------|-------------|
| | 400 ohms | 1300 ohms | 3000 cycles |
| 25°C | 5.5% | - | 5.7% |
| 70°C (hot run) | 5.97% | 3.0% | 6.4% |
| -40°C (cold run) | 5.3% | - | 5.7% |

The distortion on the marker beacon RF modulator increased slightly at the higher temperatures, but was well within the 15% distortion limit specified.

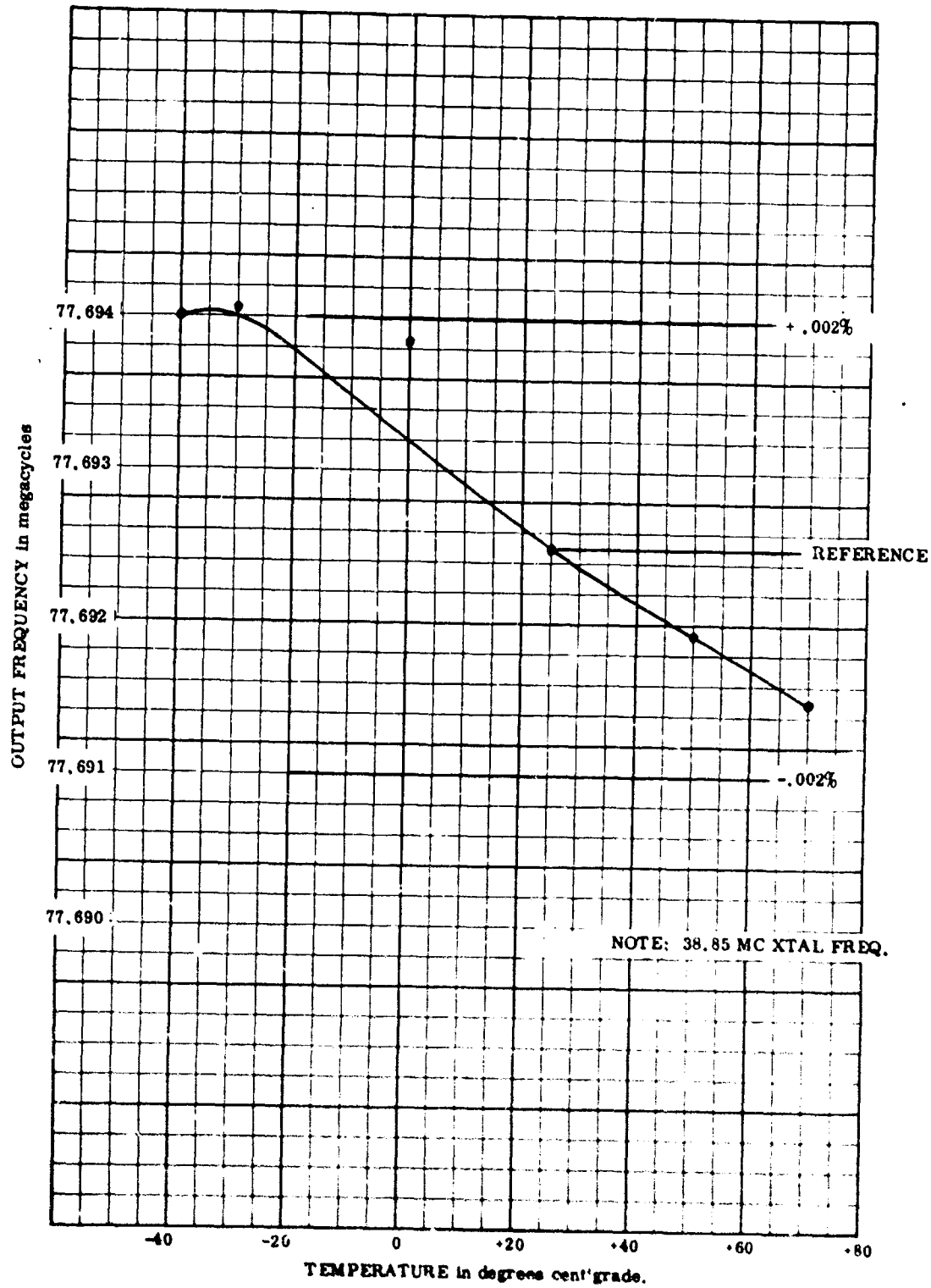

Figure 16. Glide Slope RF Modulator Frequency vs Temperature

The complete marker beacon system was given a temperature run to determine the effects of temperature variation on percent modulation. The percent modulation was set to 95% at room temperature at the start of this test. The data appears in figure 17.

The percent modulation was within the specified limits of $95 \pm 4\%$ except at extremely low temperatures.

The variation of power output versus temperature is shown in figure 18. Power output never dropped below the specified level of 1.0 watt at any point in the temperature runs; and varied less than 20% from nominal. This power variation is acceptable since it results in less than a 5% change in lamp time.

The spurious and harmonic frequencies present in the marker beacon output were observed on a spectrum analyzer and the following levels recorded:

TABLE VII - MARKER BEACON SPURIOUS AND HARMONIC FREQUENCIES

| <u>f(mc)</u> | <u>30°C</u> | <u>50°C</u> | <u>70°C</u> | <u>-10°C</u> | <u>-40°C</u> |
|--------------|-------------|-------------|-------------|--------------|--------------|
| 75 | REF | REF | REF | REF | REF |
| 37.5 | -58 | -58 | -59 | -53 | -56 |
| 112.5 | -48 | -48 | -50 | -44 | -48 |
| 150 | -25 | -27 | -27 | -22 | -22 |
| 187.5 | -48 | -48 | -51 | -46 | -51 |
| 225 | -22 | -23 | -25 | -20 | -21 |
| 262.5 | -44 | -43 | -47 | -46 | -50 |
| 300 | -39 | -39 | -39 | -36 | -51 |

The 75 mc output was used as a reference and all readings shown were measured in db below that reference level.

The trickle battery charger was removed from operation, simulating a power failure, and the marker beacon was operated on battery power alone. Tests indicated that the battery was able to sustain the marker beacon on the air for a longer period of time than the one week target time originally estimated. After seven days of operation the specific gravity of the batteries had dropped from 1250 to 1175, indicating several more days of useful life. These tests were conducted during summer temperatures and the reserve life will be helpful in providing specified service at low winter temperatures.

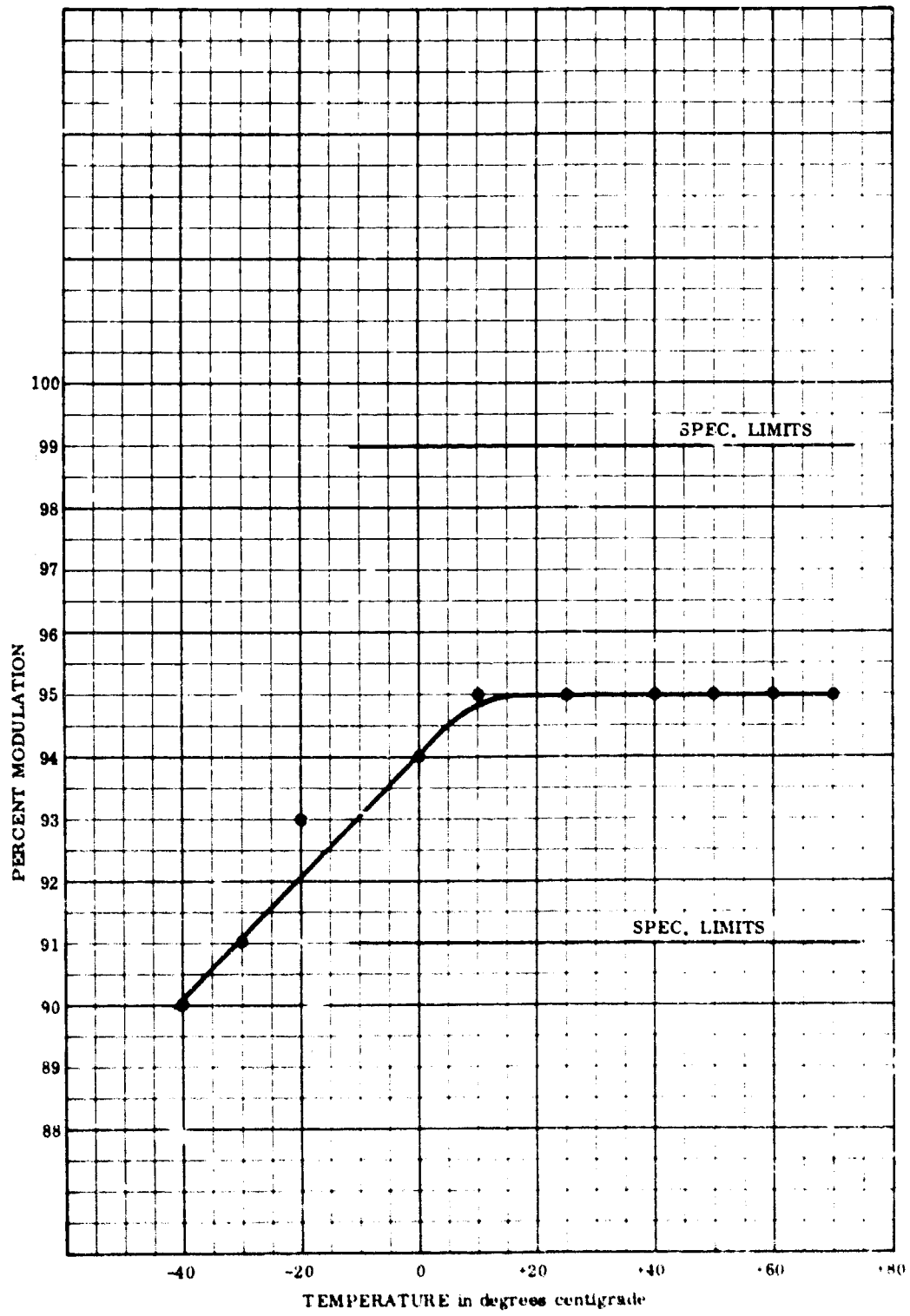

Figure 17. Glide Slope Modulation vs Temperature

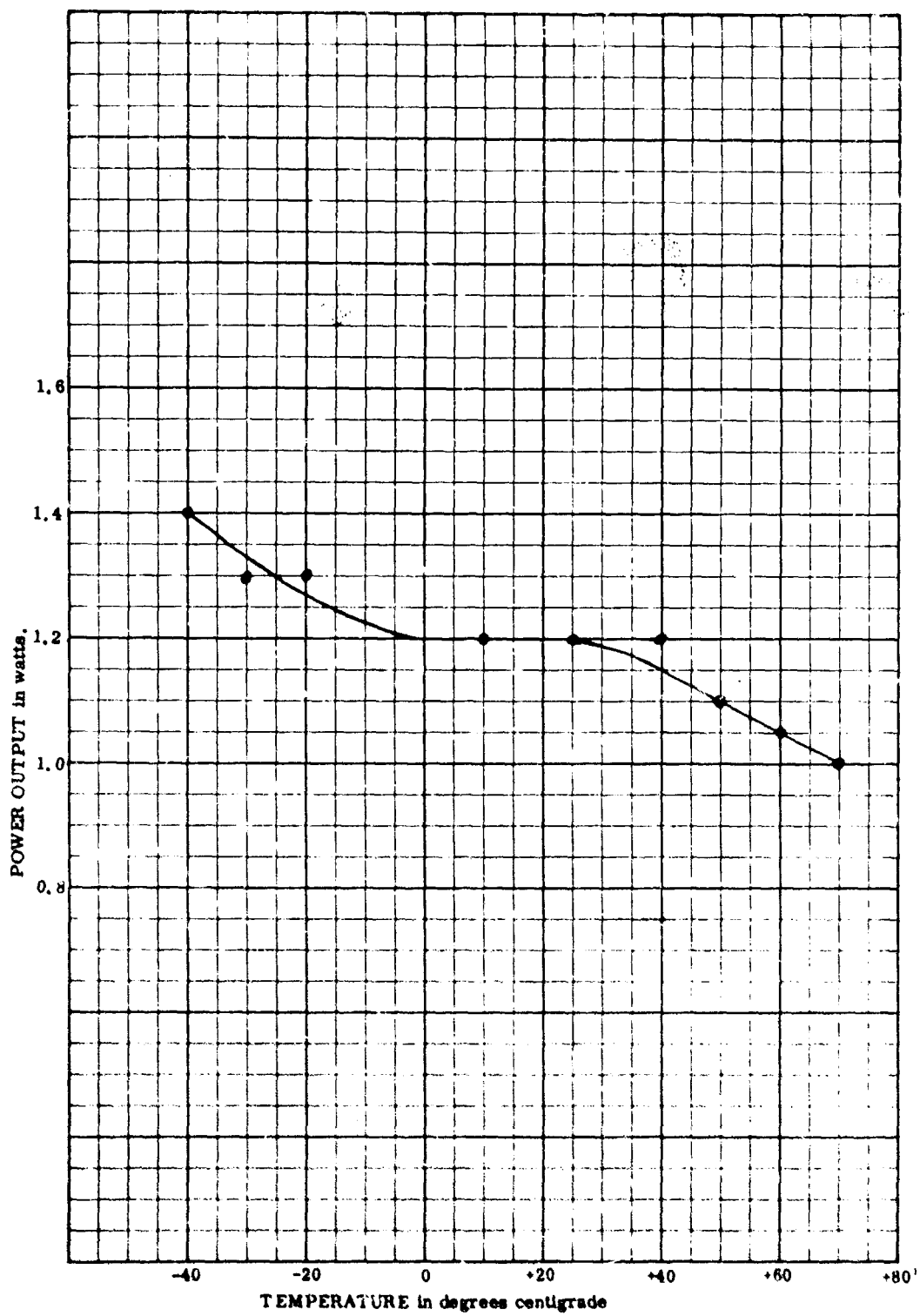

Figure 18. Glide Slope Marker Power Output vs Temperature

The marker beacon transmitter contains circuitry which senses the negative modulation peaks at audio and controls the output of the tone generator in a feedback loop designed to stabilize this audio modulation signal. The degree of control of this system was tested by inserting a variable pad in the closed loop at the tone generator output. The results of this test which simulates loss of gain at any place in the loop is shown in Table VIII below:

TABLE VIII - TONE GENERATOR OUTPUT VERSUS PERCENT MODULATION

| Attenuation (db) | Percent Modulation |
|------------------|--------------------|
| 0 | 100% |
| 1 | 99% |
| 2 | 96% |
| 3 | 93% |
| 4 | 92% |
| 5 | 90% |

With the percent modulation properly set at 95%, these results indicate that a loss of gain of more than 2 db can be experienced in the system without percent modulation going out of specified limits.

The effect of supply voltage variation was investigated and it was determined that a change in supply voltage of plus or minus one volt resulted in a change in percent modulation of less than 1%.

(3) Monitor Unit

The marker beacon monitor was designed to alarm when keying or tone are not present or when a deterioration of 50% in power occurs in transmitter radiated output. The unit is essentially a threshold sensing device designed for stable operation with as small a region of uncertainty as possible at the threshold point. The unit consists of a crystal detector, stable audio amplifier, audio detector, and keying integrator. A low differential relay is used at the dc output of the monitor circuitry to sense the alarm threshold.

The complete monitor system was tested for stability and threshold uncertainty over an ambient temperature range of -45°C to $+78^{\circ}\text{C}$. The stability of the alarm threshold over this temperature variation was 1 db in the worst case. This is a threshold variation of approximately 20% in power. The maximum threshold uncertainty was 0.3 db and is due solely to the difference between

the drop out point and the pick up point of the relay. This corresponds to an uncertainty of approximately 7%.

The threshold stability and threshold uncertainty were considered to be satisfactory for system performance. The threshold variation is compensated for in the system by setting the alarm point for a 30% decrease in power so that an alarm can be guaranteed on a 50% power loss at any ambient temperature between -40°C and $+70^{\circ}\text{C}$. The threshold uncertainty results in the equipment returning to operation when the power increases above the drop out point by a maximum of 7%.

The data on the marker beacon monitor tests appears in Table IX.

TABLE IX - ALARM RELAY THRESHOLD VERSUS TEMPERATURE

| Temperature | 400 cps | | 1300 cps | | 4000 cps | |
|-----------------------|---------------------|-----------------------|---------------------|-----------------------|---------------------|-----------------------|
| | Alarm Threshold dbm | Relay Differential db | Alarm Threshold dbm | Relay Differential db | Alarm Threshold dbm | Relay Differential db |
| $+78^{\circ}\text{C}$ | 11.0 | 0.2 | 10.7 | 0.2 | 10.0 | 0.1 |
| $+40^{\circ}\text{C}$ | 10.8 | 0.2 | 10.2 | 0.1 | 9.0 | 0.1 |
| 0°C | 11.0 | 0.2 | 10.5 | 0.1 | 9.5 | 0.2 |
| -45°C | 10.5 | 0.1 | 10.0 | 0.1 | 9.0 | 0.2 |

NOTE: Above are input signal levels from the antenna system.

(4) Keyer Tone Generator Unit

A temperature run was made to observe the modulation tone frequency variation over the service range. The results of this test are shown in figure 19.

The total frequency variation was 9 cps, or approximately 2.3 percent over the service range, and remained within the tolerance of ± 2.5 percent of the nominal frequency as per specifications.

The keyer unit was tested over the temperature range of -40°C to $+70^{\circ}\text{C}$ and was found to be within the specification limits of $\pm 15\%$. A curve of this data is given in figure 20. The data gives the dash rate versus temperature and since the dashes are directly counted from the dot output, the data is indicative of the tolerance of all the keyer outputs.

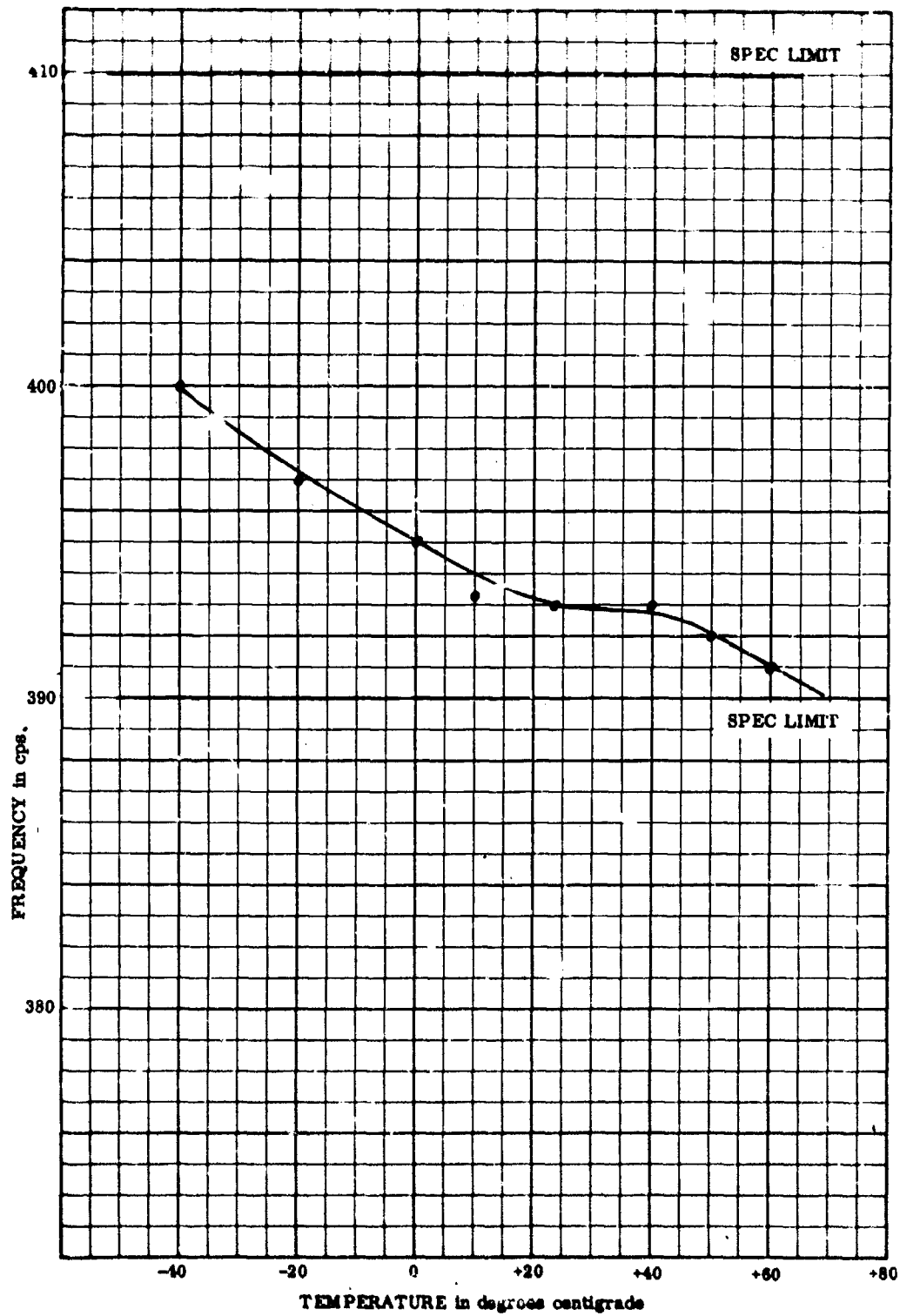

Figure 19. Glide Slope Tone Frequency vs Temperature

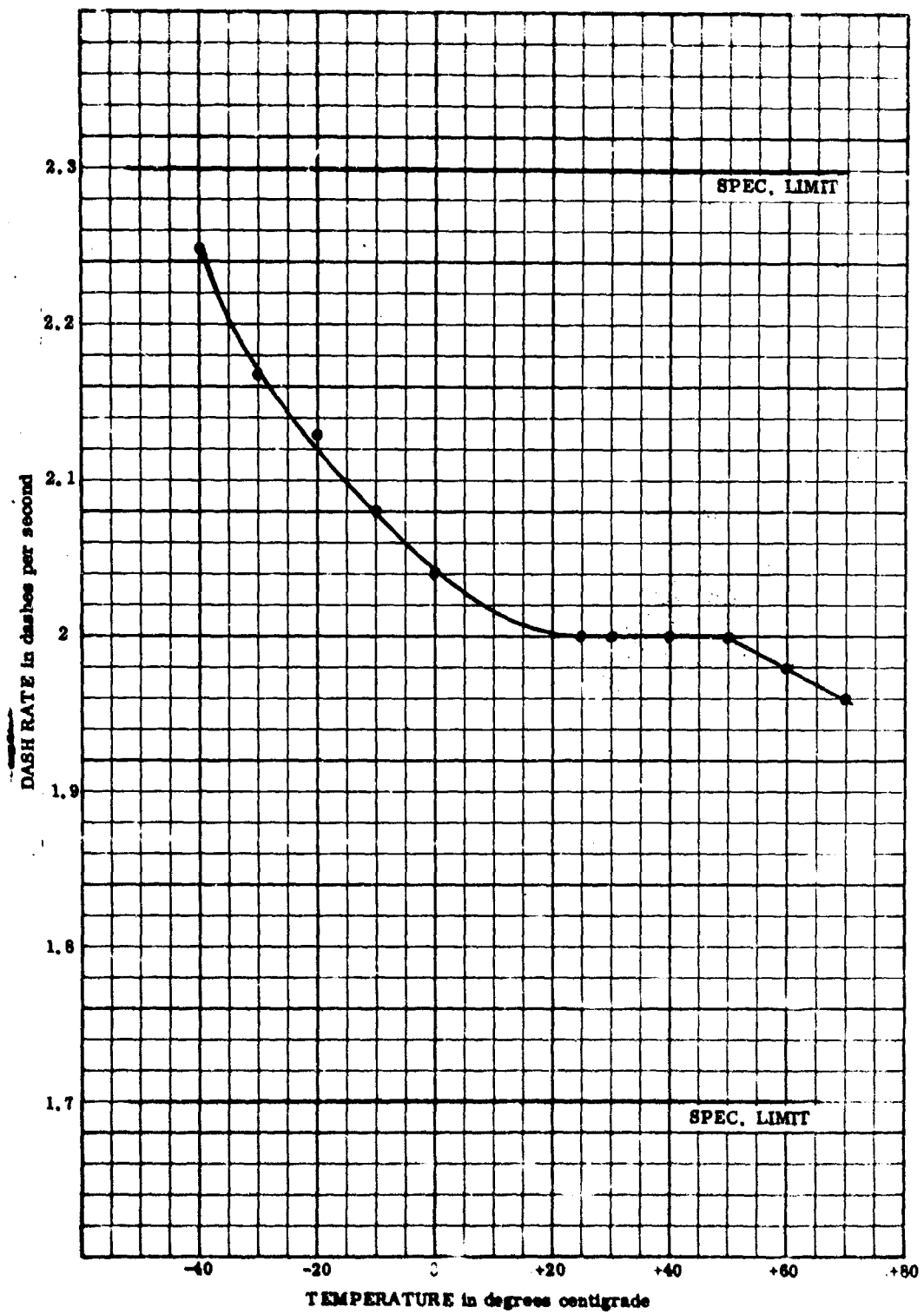

Figure 20. Glide Slope Keyer Rate vs Temperature

MARKER BEACON FLIGHT CHECK

A flight check of the Low Cost Marker Beacon System was conducted on June 26, 1964. The equipment was sited on the roof of a small shed at the ITTFL test site, located in Lincoln Park, New Jersey. The marker beacon antenna array was mounted on an aluminum pipe mast extending above the roof of the shed so that the lower radiating antenna element was approximately 24 feet above the surrounding ground plane.

The flight check aircraft used in these tests was BRAD-03 (T-29). A succession of runs were made at an altitude of 4000 feet to check the high altitude coverage of the marker beacon system. Runs were made at 130 knots directly over the station and out to a distance of 8000 feet (east and west) of the station. Results indicated that the signal received on the high sensitivity setting of the aircraft receiver was usable to a distance of 8000 feet off a centerline in the plane with the antenna elements. At the 8000 feet point however, noticeable degradation in lamp brilliance was noted indicating the limit of coverage. No lamp indications were observed on the low sensitivity setting of the airborne receiver at the 4000 foot altitude. See Table X for the data at the 4000 feet altitude.

TABLE X - MARKER BEACON FLIGHT CHECK DATA

| Distance from Antenna Centerline (feet) | Lamp Duration (seconds) | Aircraft Heading |
|--|-------------------------|------------------|
| on centerline | 63 | north |
| 1000 west | 59 | south |
| 3000 east | 56 | north |
| 3000 west | 65 | south |
| 5000 east | 60 | north * |
| 5000 west | 62 | south |
| 8000 east | 50 | north * |
| 8000 west | 30 | south * |
| * Lamp not at full brightness Altitude - 4000 feet Speed - 130 knots | | |

A check was also conducted on the marker beacon antenna pattern at 1000 feet altitude at a speed of 130 knots. On centerline the lamp duration was ten seconds at this altitude. No lamp indication was evident 3000 feet in either

direction off centerline. All runs at 1000 feet were at low sensitivity and system performance was considered acceptable.

GLIDE SLOPE SYSTEM FLIGHT TESTS

As a result of limited availability of a flight test aircraft and adverse weather conditions, only a cursory flight check was made while the equipment was set up for field tests. However, since the only novel feature in the antenna array is the use of double elements to restrict the horizontal radiation, and patterns were taken on the individual elements, formal flight checks were not considered a necessity. The two on-path checks conducted indicated that the system generated a usable glide path similar to that radiated by other systems previously tested at the same location. Extensive flight checks of the equipment will be made when installed.

CONCLUSIONS AND RECOMMENDATIONS

Engineering test results indicate that the Glide Slope Transmitter TU-8X, Glide Slope Field Detector TU-8X/1, and Glide Slope Tower Unit TU-8X/2 complete with shelter and null reference antenna system conform to the technical requirements of ICAO Category II standards.

Preliminary flight tests also indicate that glide path sensitivity and coverage are also in accordance to the latest ICAO Category I standards.

The marker beacon system consisting of marker beacon transmitter type TV-33X complete with weatherproof housing and antenna system, has been developed, tested, and found to be in accordance with the requirements of the contract work statement and the ICAO Annex 10 standards for markers.

Initial flight tests indicate that wide angle coverage at 4000 feet is obtained by the system.

Pending the results of the system evaluation program underway at the Jamestown, New York airport, the modifications recommended in the system are in the sideband generator unit, the glide slope field detector IF subunit, and the high voltage power supply.

The cost of the presently incorporated sideband generator can be reduced by several orders by more development effort. The work on the IF subunit and the high voltage is also a value engineering effort which should result in simplified units capable of production at lower cost than the present circuits.

APPENDIX A

**This appendix contains the drawings rendered
under the subject contract.**

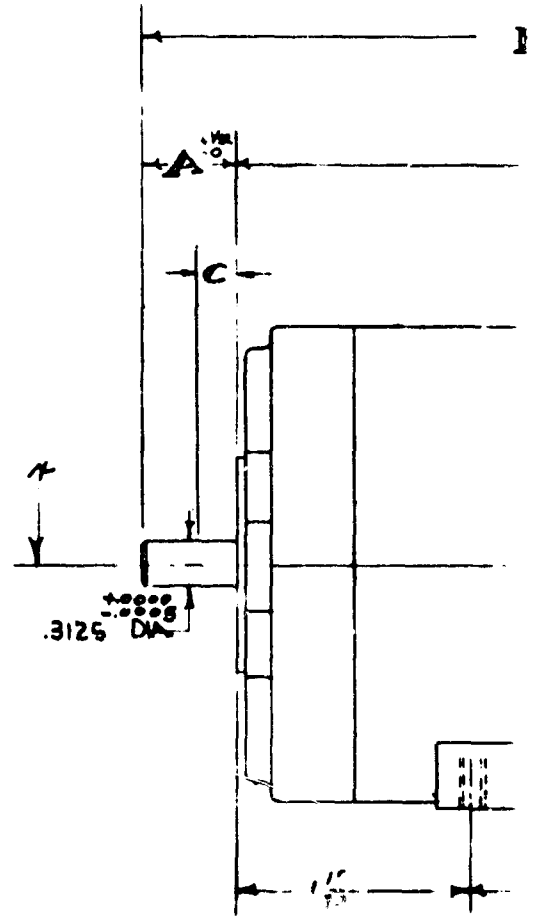
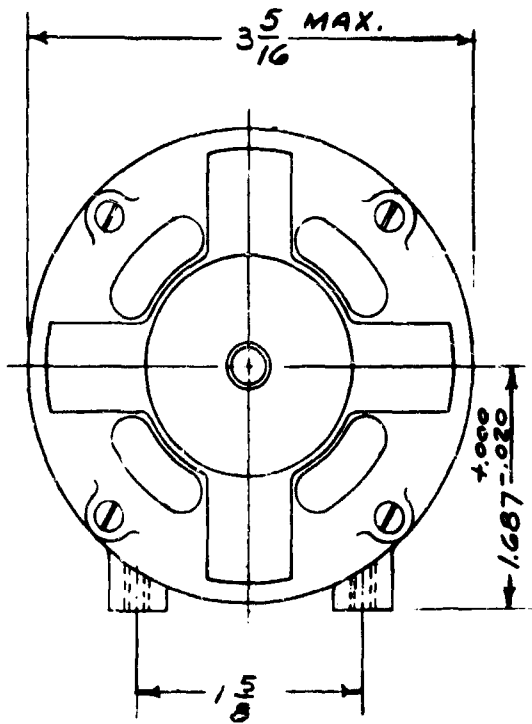

| PART N ^o | DIM. A | DIM. B |
|---------------------|--------|--------|
| E120782-1 | 1 1/16 | 5/8 |
| E120782-2 | 2 9/32 | 9/8 |

MOTOR PER
 HYSTERE
 CAPACIT
 PHASE
 CYCLE
 VOLT
 H.P.
 RPM
 DUTY
 TEMP
 AMBIE
 CAPA
 ST
 OBST
 EC

SHIPPING INSTRUCTIONS:

METHOD OF SHIPPING & HANDLING
SHALL BE COMMENSURATE WITH THE
SHAFT STRAIGHTNESS SPECIFIED

005 TOTAL INDICATOR READING BET
MAX. RUNOUT AT EXTREMES OF
MOTOR TO BE IN ACCORDANCE WITH
MANUFACTURED BY INDUCTION M.

A

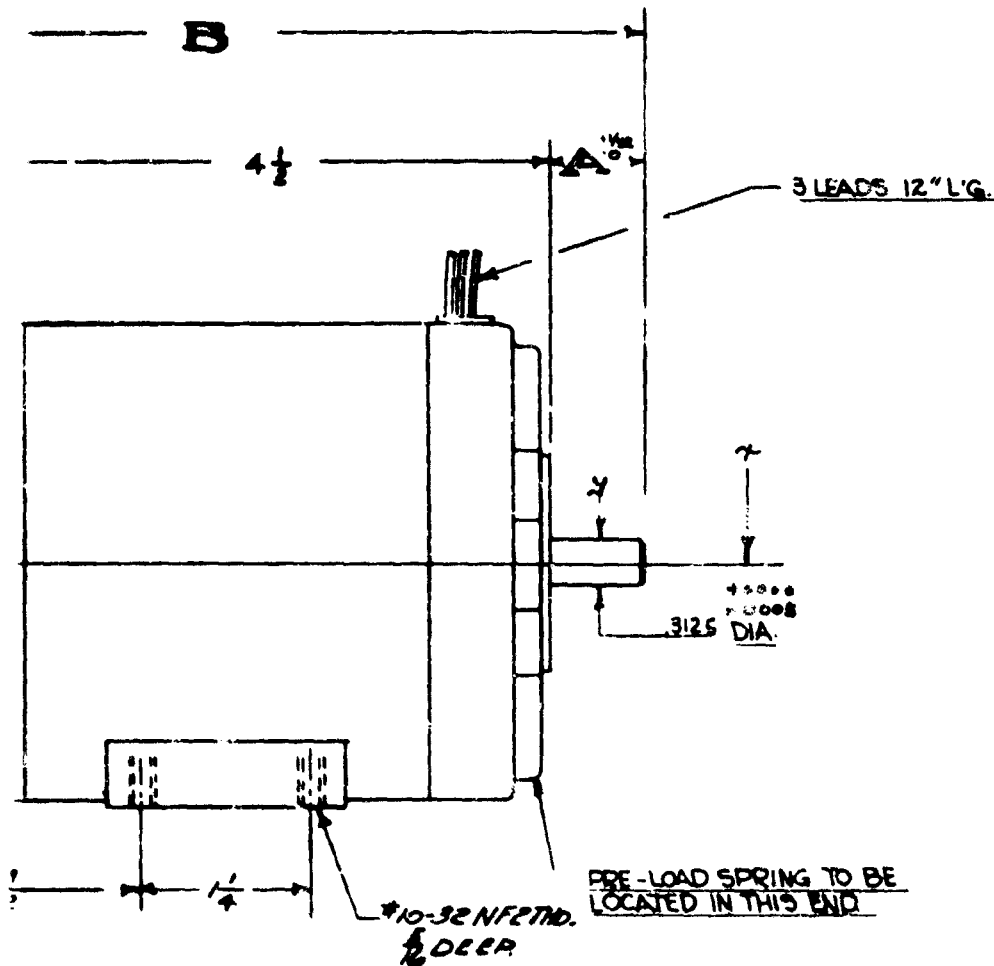

MOTOR PERFORMANCES:

HYSTERESIS TYPE, CLASS "A", SELF-VENTILATED MOTOR.

CAPACITOR START & RUN, SPECIALLY DESIGNED TO MELT FOLLOWING SPEC'S.:

PHASE 31

CYCLE = 60

VOLTS = 115 ± 10%

H.P. = 1/75

RPM = 1800

DUTY = CONTINUOUS

TEMP RISE = 29°C AT +76°C AMBIENT FOR CLASS A, 44°C AT +76°C FOR CLASS M

AMBIENT TEMP RANGE: -40°C TO +76°C

CAPACITOR SEPARATELY MOUNTED - OVERLOAD PROTECTION REQUIRED - STAINLESS

STEEL SHAFT - SPECIAL GREASED BEARINGS BY RMB # KF 022 - IN ACCORDANCE WITH AN-6-25

OBSTRUCTION TO MOTOR COOLING AIR FLOW - THE MINIMUM DIMENSION BETWEEN AN OBSTRUCTION EQUIVALENT TO A FLAT PLATE & END BELL (DIMENSION C) WILL BE 1/8 INCHES.

READING BETWEEN #14 PARALLEL TO BASE
RUNDS OF SHAFT NOT TO EXCEED .001 T. I. R.
CONFORM WITH F.T.L. SPECIFICATION A 2120753.
INDUCTION MOTORS, CORP., L.I., N.Y.

Figure A-1. Motor-Hysteresis - Class "A"
Modulator (C2120782)

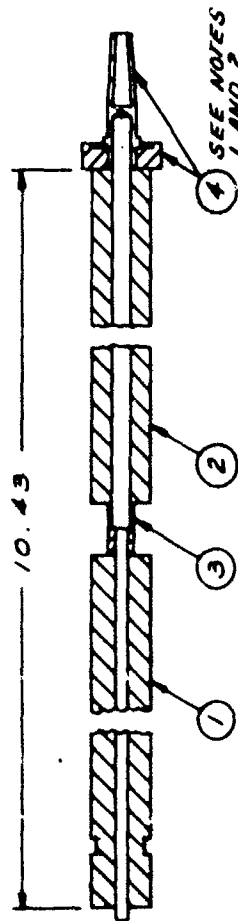

- NOTES:
1. PARTS SHOWN ARE BUSHING INSULATOR AND ELECTRICAL CONTACT WHICH ARE REMOVED FROM CONNECTOR UG-7196A/U AND USED AS SHOWN. OTHER PARTS OF CONNECTOR WILL BE USED ON FINAL ASSEMBLY.
 2. PLACE BUSHING ON CONTACT BEFORE ASSEMBLING TO ITEM 2 WITH ITEM 5. ASSEMBLE ITEMS 1, 2 & 3 WITH ITEM 5.

| LIST OF MATERIAL | | PART OR IDENTIFYING NO. | | NOMENCLATURE OR DESCRIPTION | | ITPA SOURCE |
|--------------------|----------|-------------------------|-------|-----------------------------|-----------------------------------|-------------|
| QTY | ITEM NO. | CODE | IDENT | NO. | | |
| 20 | 3 | | | A2132470 | PROCESS, SOFT SOLDERING | |
| 1 | 4 | | | 256253 | CONNECTOR, RF, TYPE UG-1186A/U | |
| 1 | 3 | | | B2157324 | CENTER CONDUCTOR CONNECTOR | |
| 1 | 2 | | | B2157325 | CABLE, RF, COAXIAL, TYPE RG-87A/U | |
| 1 | 1 | | | B2157326 | QUARTER WAVE 75 OHM TRANSFORMER | |
| 68 | 63 | 64 | 63 | 61 | | |
| QUANTITY PER GROUP | | | | | | |

Figure A-2. Center Conductor Assembly (B2157323)

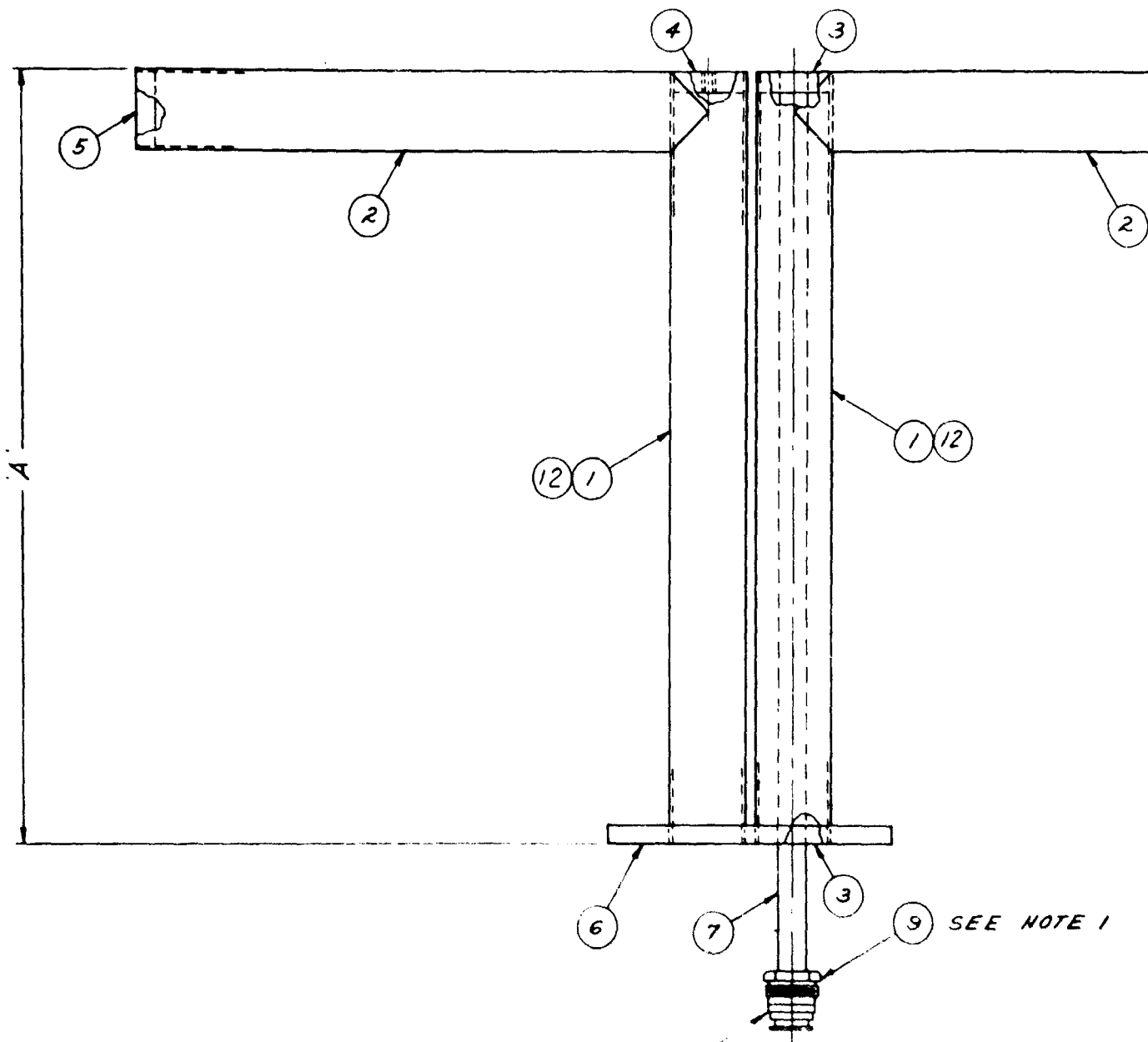

SOFT SOLDER IN PLACE (13)

SEE NOTE 1 (9)

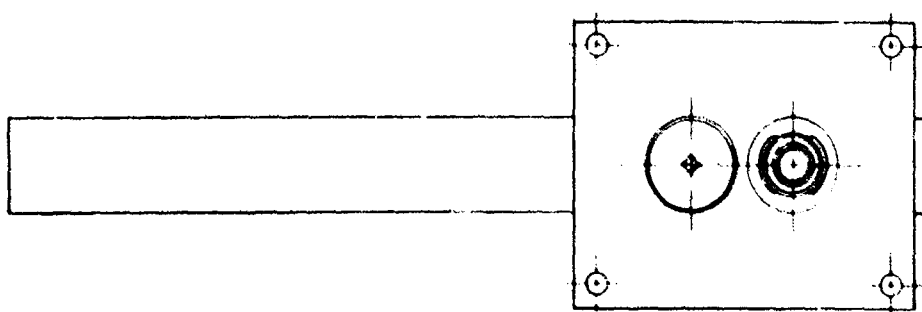

A

NOTES:

1. PART SHOWN IS ELECTRICAL CABLE CLAMP WHICH IS REMOVED FROM CONNECTOR UG-1186A/U AND USED AS SHOWN. OTHER PARTS OF CONNECTOR USED ON FINAL ASSEMBLY.
2. ASSEMBLE ITEMS 3, 4, 5, 7, 8 & 9 WITH ITEM 11.
3. ASSEMBLE ITEMS 1, 2 & 6 WITH ITEM 10.

| | |
|-----------|-------|
| PART NO | A |
| 215733061 | B.688 |
| G2 | B.875 |

| LIST OF MATERIAL | | | | | | |
|------------------|---|----|----|---|-----------|--------------------------------|
| 1 | 1 | 1 | 13 | B | 215 | SEAL, CONDUCTOR |
| 2 | - | 1 | 2 | B | 215750762 | TUBE FEED |
| X | X | 20 | 11 | A | 2152470 | PROCESS, SOFT SOLDERING |
| X | X | 20 | 10 | A | 2132497 | PROCESS, SILVER SOLDERING |
| X | X | 1 | 9 | | 756253 | CONNECTOR, RP, TYPE UG-1186A/U |
| 1 | 7 | 2 | 8 | | | |
| 1 | 1 | 1 | 7 | B | 2157227 | OUTER CONDUCTOR |
| 1 | 1 | 1 | 6 | B | 2157210 | PLATE, MFG |
| 2 | 2 | 1 | 5 | B | 215730963 | CAP. END |
| 1 | 1 | 1 | 4 | B | 215730962 | CAP. END |
| 2 | 2 | 1 | 3 | B | 215730961 | CAP. END |
| 2 | 2 | 1 | 2 | B | 2157508 | TUBE, DIPOLE |
| - | 2 | 1 | 1 | B | 215730761 | TUBE FEED |

Figure A-3. Dipole Soldering Assembly
(D2157330)

A-4

B

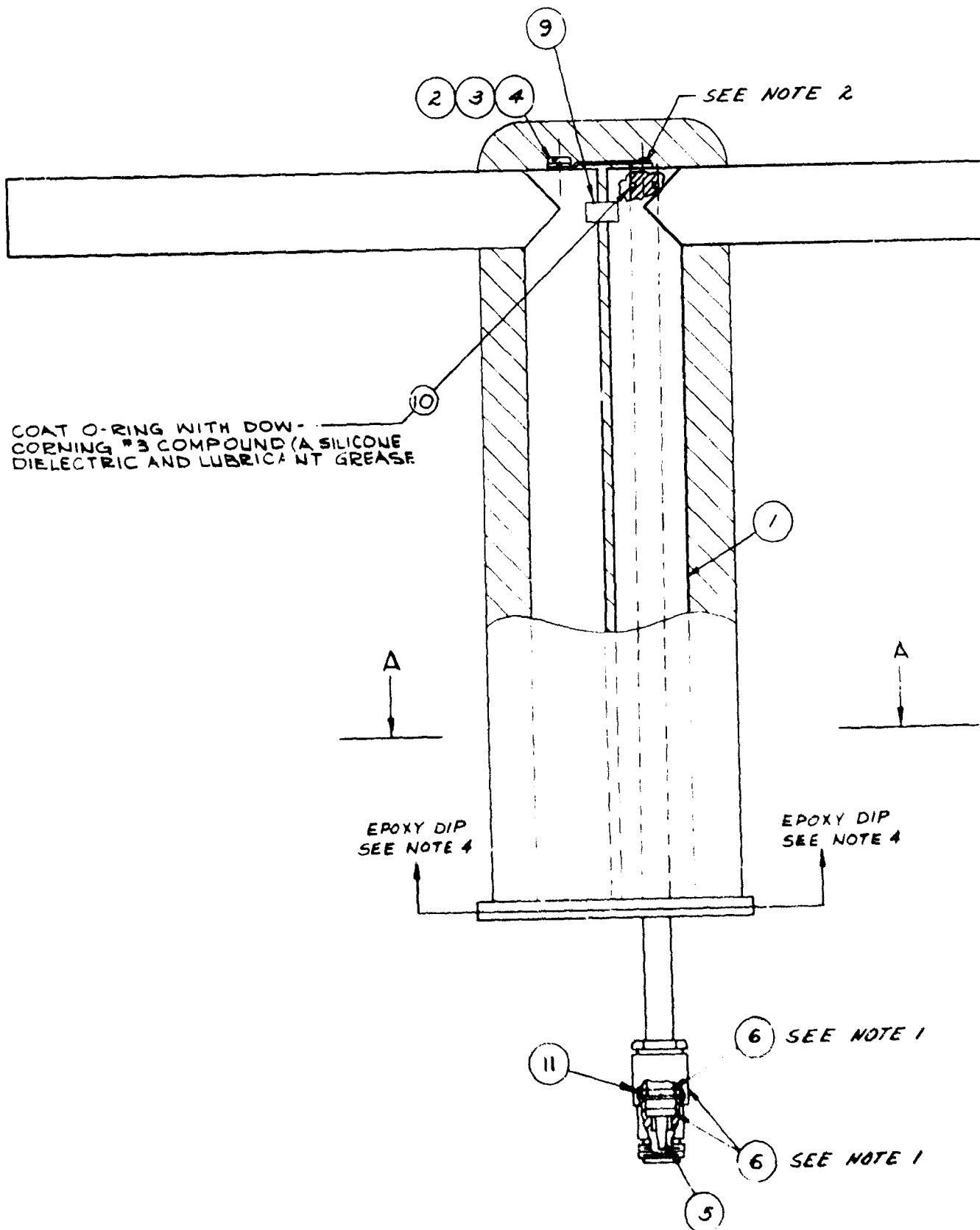

A

SEE NOTE 2

NOTES:

1. PARTS SHOWN ARE ~~HOLEDING WASHER~~, BUSHING INSULATOR AND ELECTRICAL CONNECTOR SHELL WHICH ARE USED FROM CONNECTOR UG-1186A/U. SEE DWG D2157330 & B2157323 FOR OTHER PARTS OF CONNECTOR USED.
2. ASSEMBLE ITEMS 4 & 5 WITH ITEM 7.
3. ENCAPSULATE WITH FOAM POLYURETHANE EQUIVALENT TO HETROFOAM 190/191 MANUFACTURED BY DUJEEZ PLASTICS DIVISION, HOOKER CHEMICAL CORP, NORTH TONAWANDA, N Y
4. ENTIRE ENCAPSULATED ELEMENT TO BE DIPPED IN EPOXY TO BASE PLATE. WHITE PIGMENTED EPOXY TO BE USED TO GIVE OPAQUE WHITE FINISH. (CONT'D)



EPOXY DIP
SEE NOTE 4

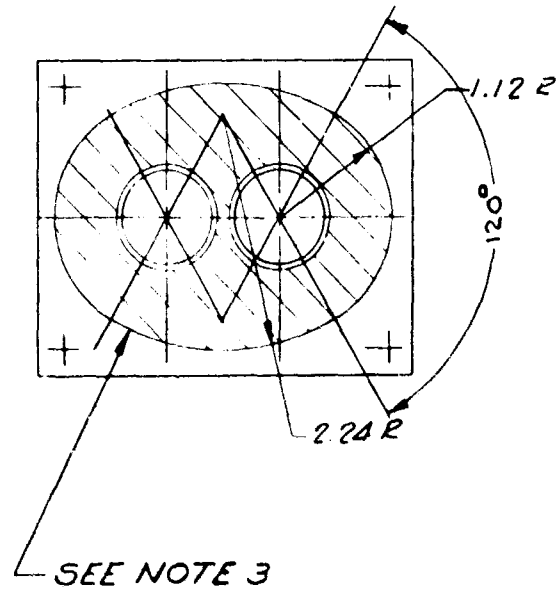

NOTE 4 (CONT'D)

EPOXY COAT TO BE NOT LESS THAN 1/64" THICKNESS AND SHALL BRIDGE AND FILL ANY VOIDS BETWEEN ENCAPSULATION AND THE ELEMENT.

6 SEE NOTE 1

6 SEE NOTE 1

Figure A-4. ILS Glide Slope Dipole (D2157331)

A-5

B

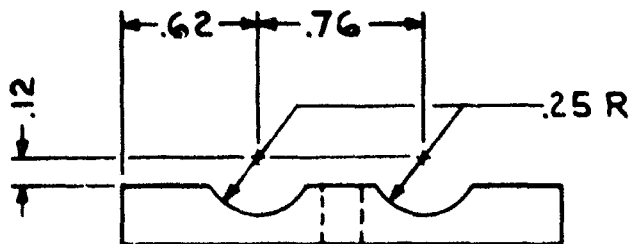
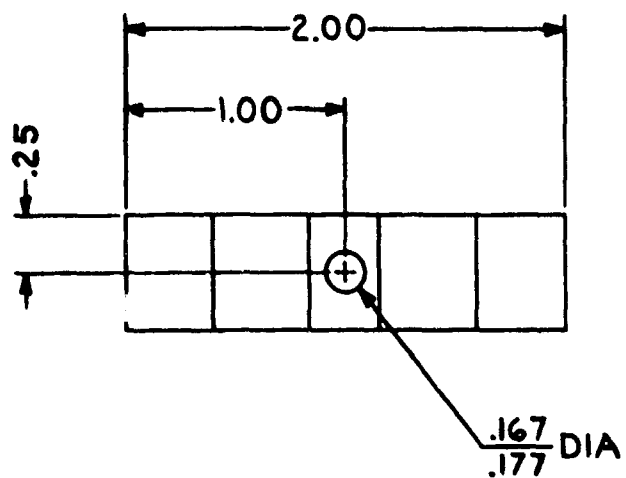

| |
|-----------------------|
| LIST OF MATERIAL |
| ALUMINUM, ALLOY, ROD, |
| RECT, 1/4 X 1/2, |
| TYPE 2024-T4 |

FINISH:

ALKALINE DIP (ROUGH ETCHED FROSTY-WHITE FINISH) THEN APPLY PROTECTIVE COATING (IRILAC 1000 ALLIED RESEARCH PROP, INC.)

Figure A-5. Clamp (C2205169)

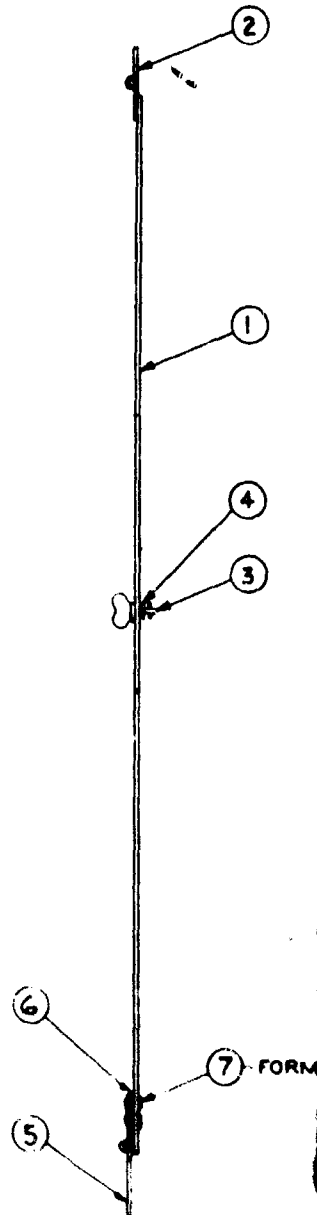
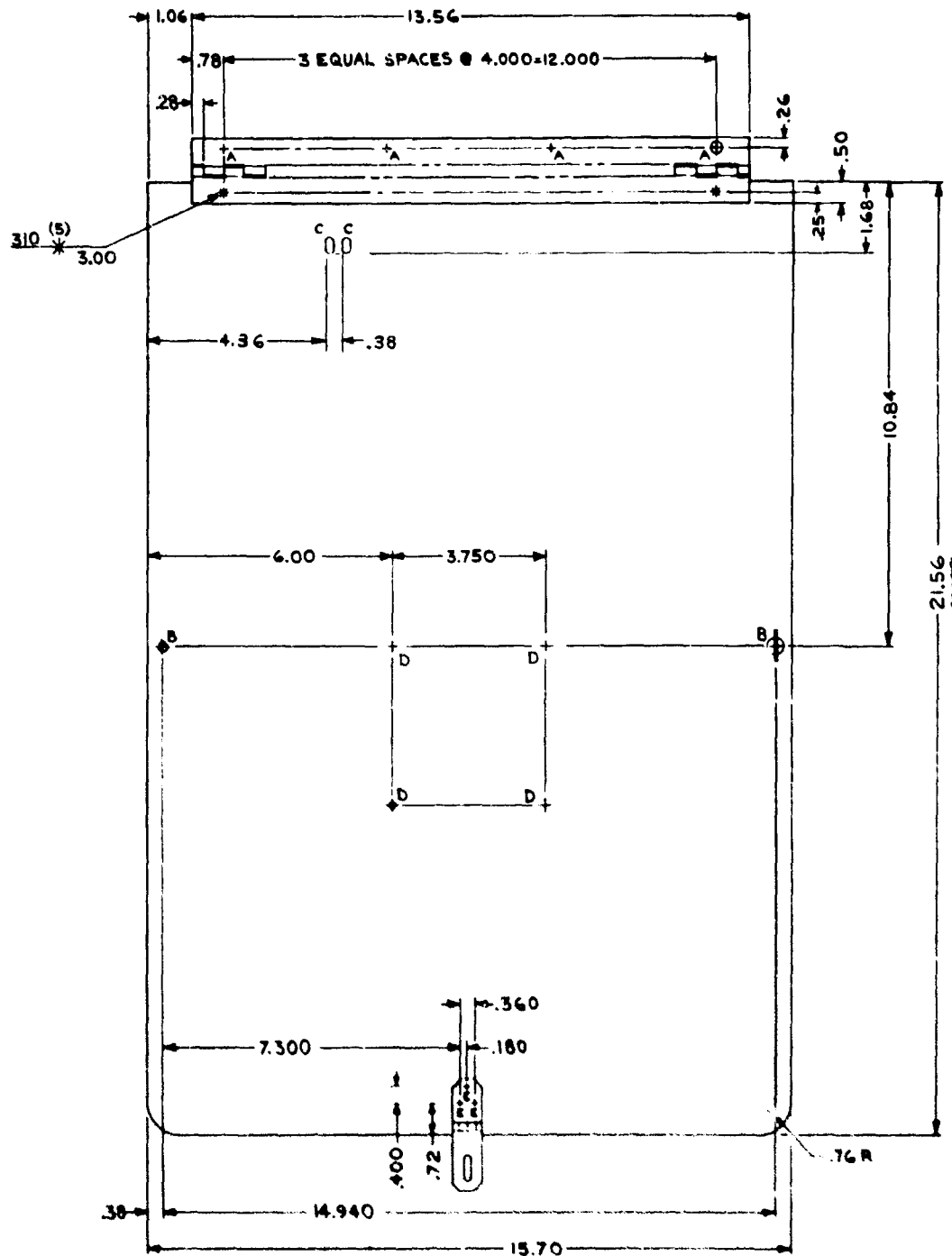

FINISH:
ALK
FINI
(IRN)

LIST OF MATERIAL

| GROUP | QTY | UO | ITEM | PART OR IDENTIFYING NO. | NOMENCLATURE OR DESCRIPTION |
|-------|-----|----|------|-------------------------|---|
| 62 | 52 | 6 | M | NO. | |
| | 3 | 1 | 7 | 110105H614 | RIVET, SOLID, ALUM, UNIV HD. 5/32 DIA x 7/16 LG |
| | 1 | 1 | 6 | 2367335G1 | SHIM |
| | 1 | 1 | 5 | | HASP, HINGE (CORBIN CAB. LOCK DIV #03000) |
| | 2 | 1 | 4 | 315494 | RETAINER (CRES) |
| | 2 | 1 | 3 | 315073A110 | FASTENER, MINIATURE STUD (CRES) |
| | 1 | 1 | 2 | MS20257-4 | HINGE CONTINUOUS |
| | 1 | 1 | 1 | | ALUMINUM ALLOY, SHEET, .090 THK, TYPE 5052 H32 |

A

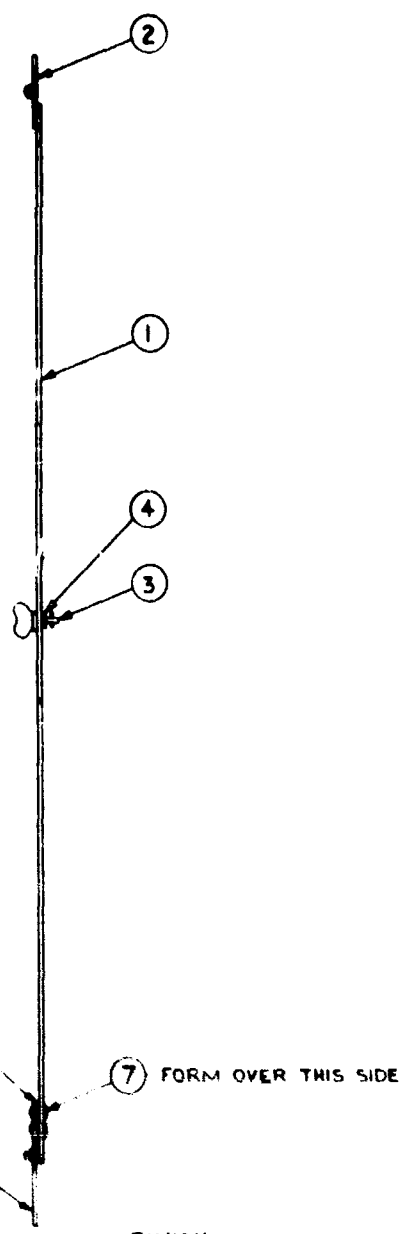
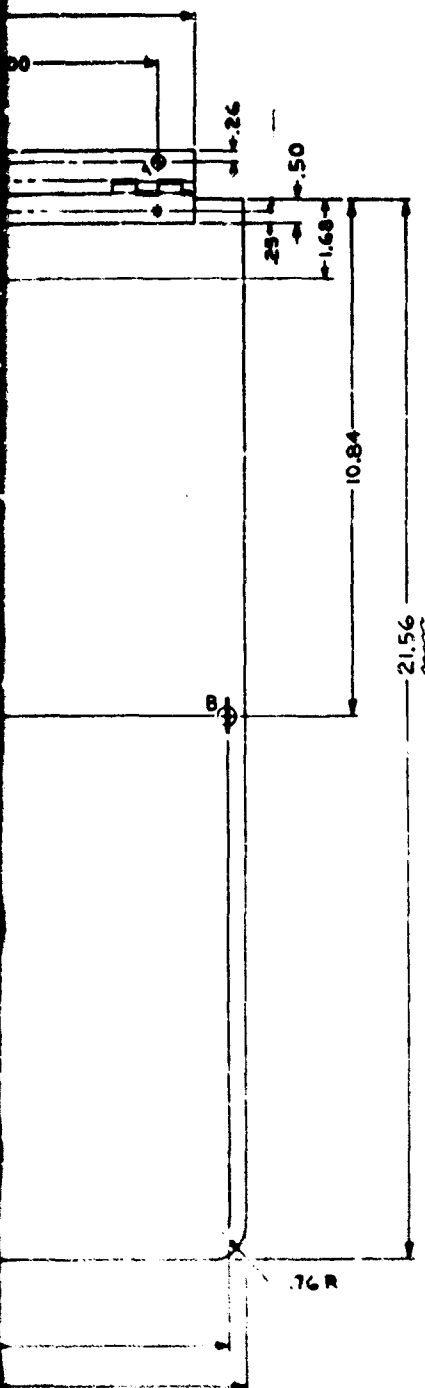

| HOLE | DESCRIPTION |
|------|---------------|
| A | .204-.214 DIA |
| B | .229-.239 DIA |
| C | SEE DETAIL I |
| D | .135-.145 DIA |
| E | .161-.165 DIA |

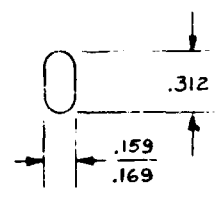

DETAIL I
(SCALE 2:1)

FINISH:
ALKALINE DIP (ROUGH ETCHED FROSTY-WHITE FINISH) THEN APPLY PROTECTIVE COATING (IRILAC®1000 ALLIED RESEARCH PROP, INC)

| MATERIAL |
|--|
| TERMINATION OR DESCRIPTION |
| SOLID ALUM. UNFIN. HD 3/32 DIA # 7/16 LG |
| HINGE (CORBIN CAB. LOCK DIV # 03004) |
| SCREW (CRS) |
| MINIATURE STUD (CRS) |
| CONTINUOUS |
| ALLOY SHEET .090 THK TYPE 5052 H32 |

Figure A-6. Door Inner (D2205170)

A-7

B

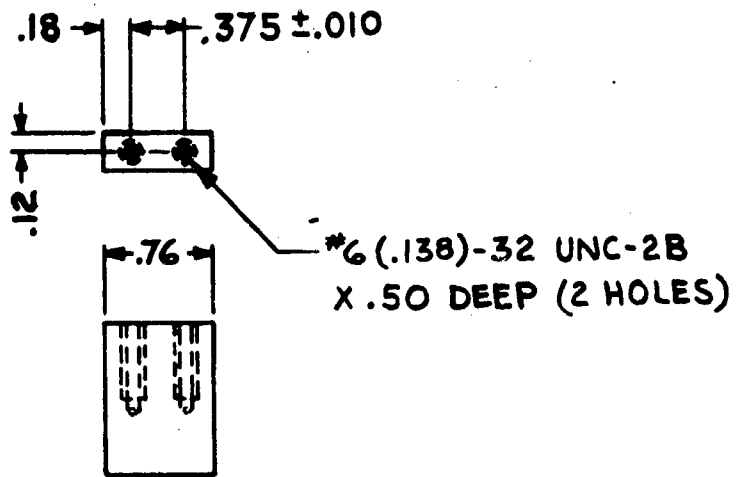

| LIST OF MATERIAL |
|---|
| STEEL, CRE, RECT, BAR, 1/4 X 1", ANL, AISI 304, PER QQ-S-763, CLASS I, TYPE A. |

Figure A-7. Stop (B2205171)

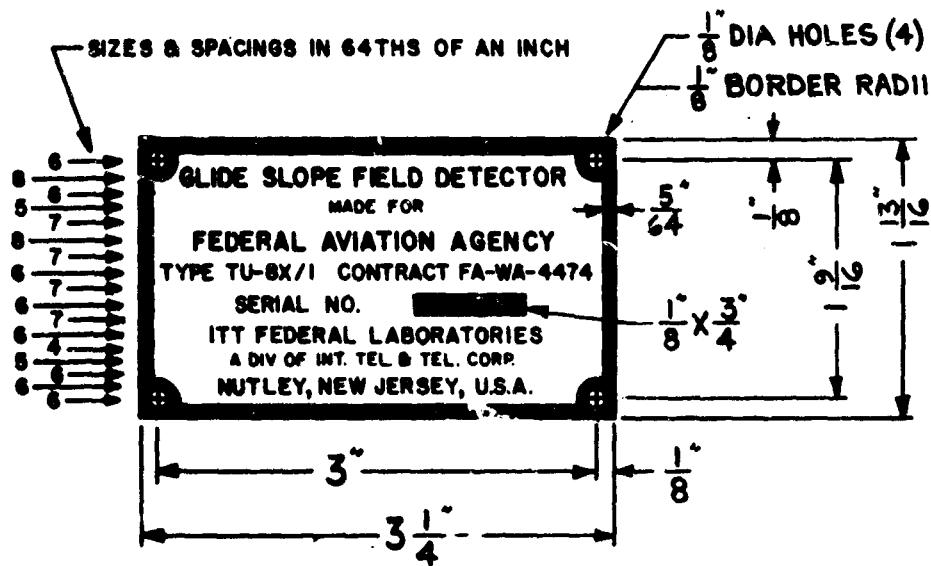

NOTES:

1. MATERIAL: .032" ALUMINUM WITH OVERALL WATER-DIP-LACQUER FINISH.
2. REVERSE ETCH; THE FOLLOWING TO BE RAISED, WITH DULL METAL FINISH: BORDER, SERIAL NUMBER BLANK, AND ALL LETTERS AND NUMBERS EXCEPT SERIAL NUMBER; DEPRESSED BACKGROUND FINISHED IN BLACK ENAMEL.
3. SERIAL NUMBER: ENGRAVE OR DIE STAMP.
4. TOLERANCE ON DIMENSIONS $\pm .010$ " EXCEPT HOLE SIZE & HOLE-TO-HOLE SPACING $\pm .005$ ".

Figure A-8. Nameplate (A2205172)

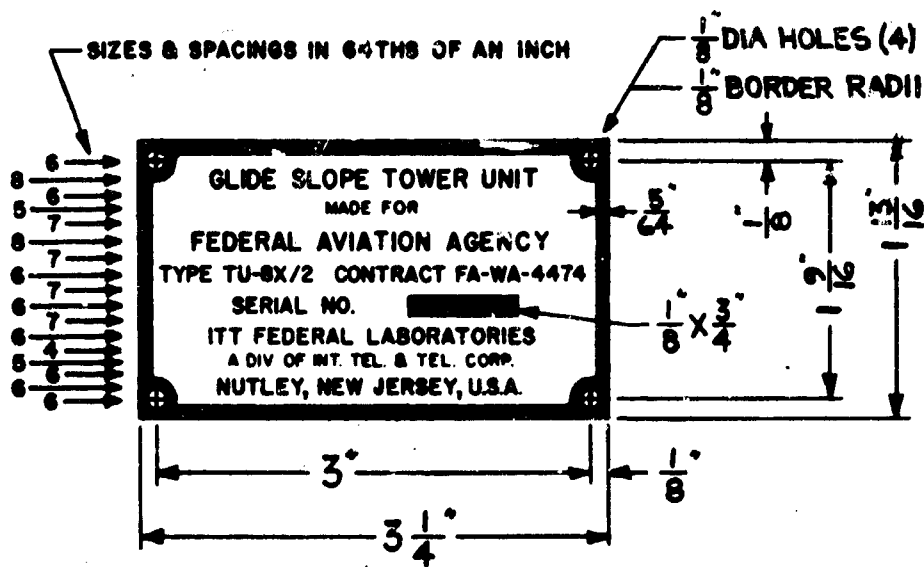

NOTES:

1. MATERIAL: .032" ALUMINUM WITH OVERALL WATER-DIP-LACQUER FINISH.
2. REVERSE ETCH; THE FOLLOWING TO BE RAISED, WITH DULL METAL FINISH: BORDER, SERIAL NUMBER BLANK, AND ALL LETTERS AND NUMBERS EXCEPT SERIAL NUMBER; DEPRESSED BACKGROUND FINISHED IN BLACK ENAMEL.
3. SERIAL NUMBER: ENGRAVE OR DIE STAMP.
4. TOLERANCE ON DIMENSIONS $\pm .010$ " EXCEPT HOLE SIZE & HOLE-TO-HOLE SPACING $\pm .005$ ".

Figure A-9. Nameplate (A2205173)

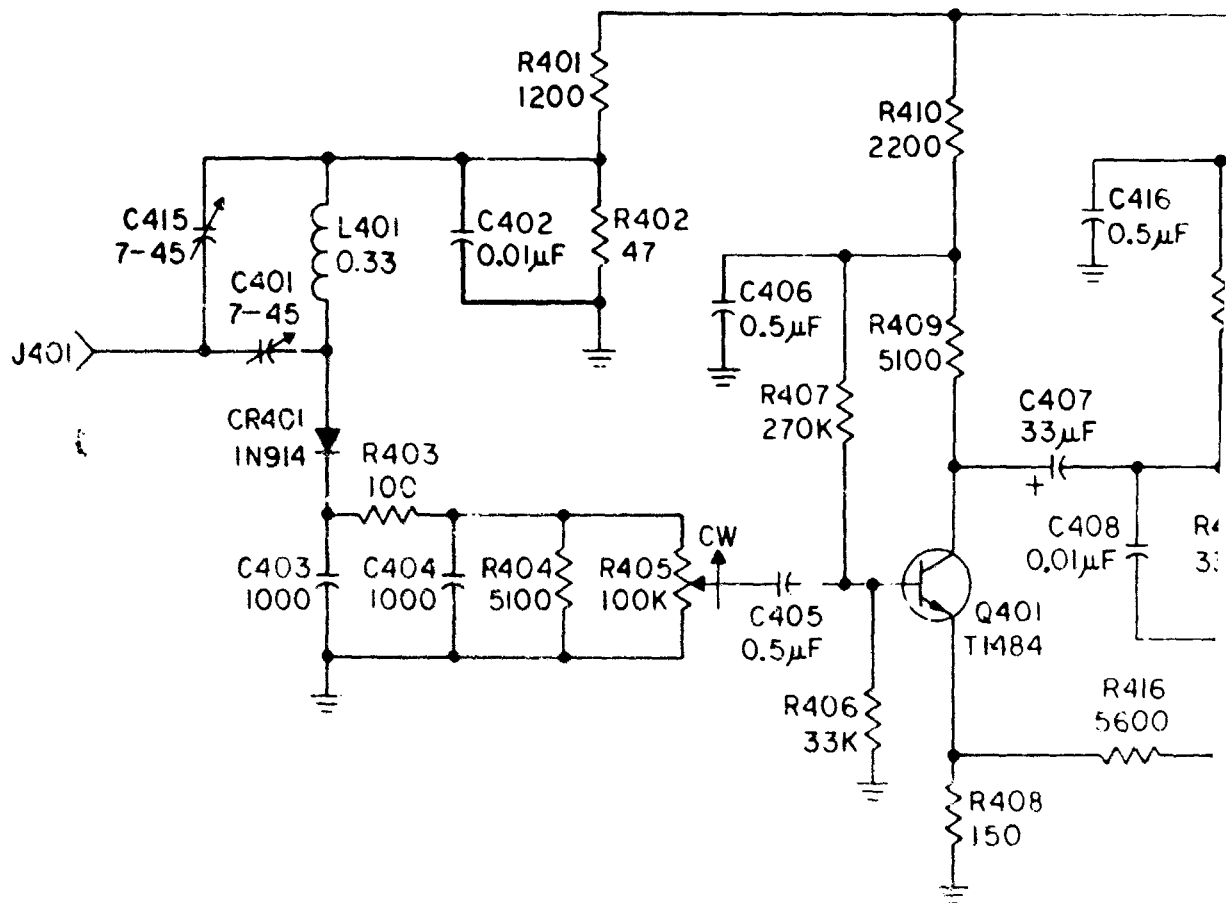

| HIGHEST REFERENCE | | | |
|--------------------|------|------|-------|
| R423 | C416 | Q407 | CR405 |
| REFERENCE DESIGNAT | | | |
| | | | |
| | | | |

A

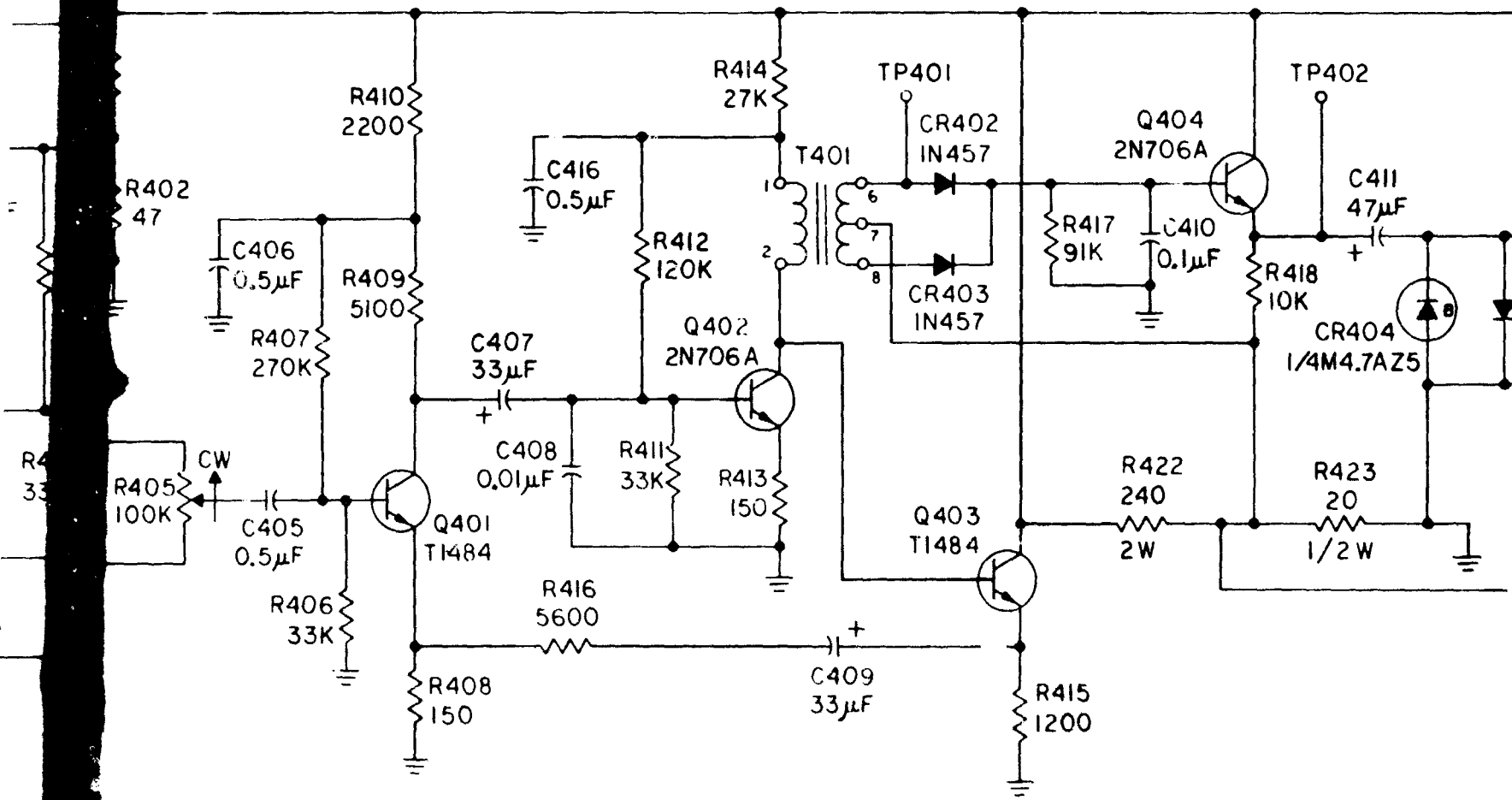

NOTES:
 I. UNLESS
 RESIST,
 CAPACI
 INDUCT

| HIGHEST REFERENCE DESIGNATIONS | | | |
|---------------------------------|------|------|-------|
| R423 | C416 | Q407 | CR405 |
| REFERENCE DESIGNATIONS NOT USED | | | |
| | | | |
| | | | |
| | | | |

B

ICE
 405
 VATI

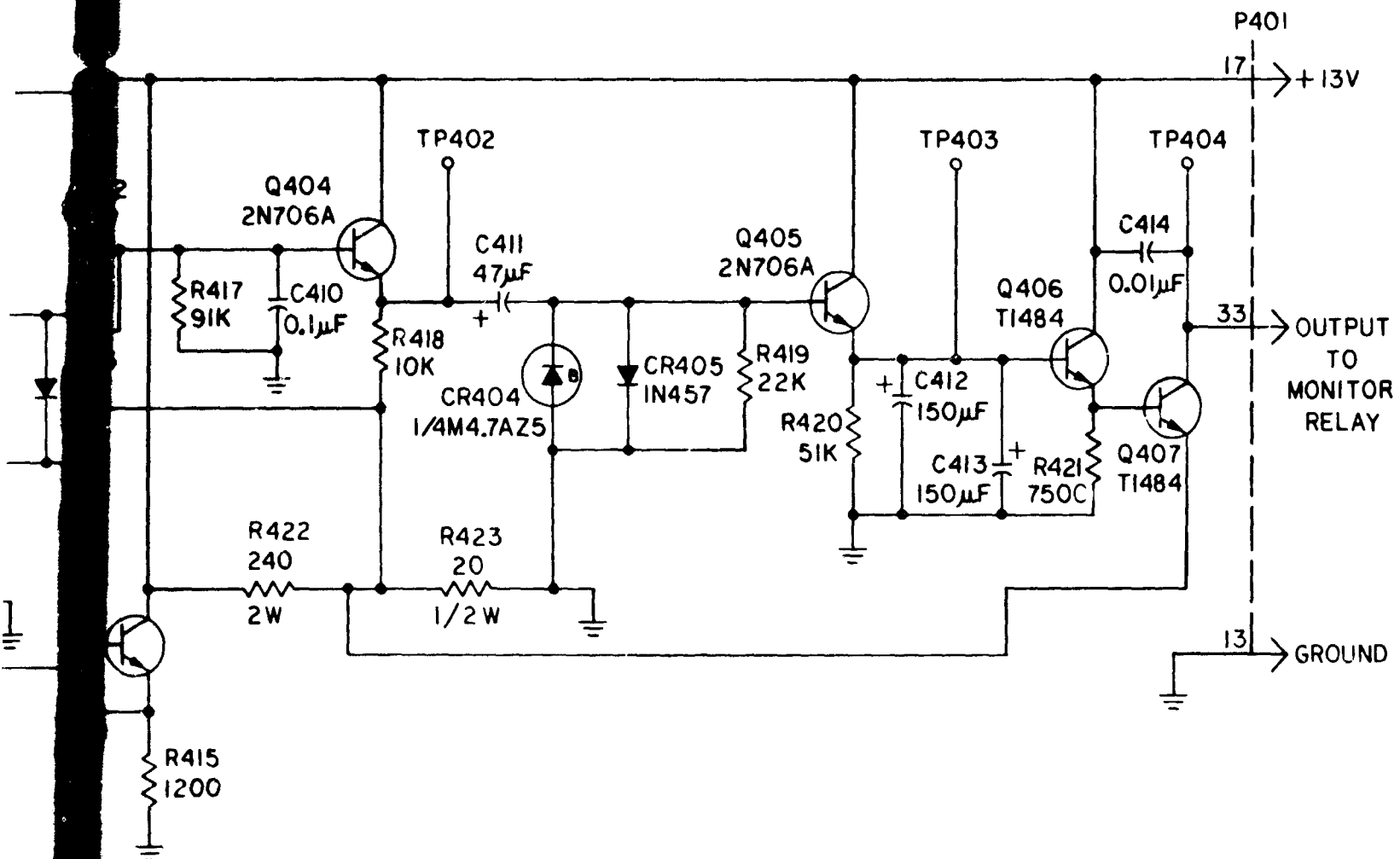

NOTES:

- I. UNLESS OTHERWISE SPECIFIED:
 RESISTANCE VALUES ARE IN OHMS.
 CAPACITANCE VALUES ARE IN PICO FARADS.
 INDUCTANCE VALUES ARE IN MICROHENRIES.

Figure A-10. Schematic Diagram,
 Monitor Marker Beacon (E2205177)

C

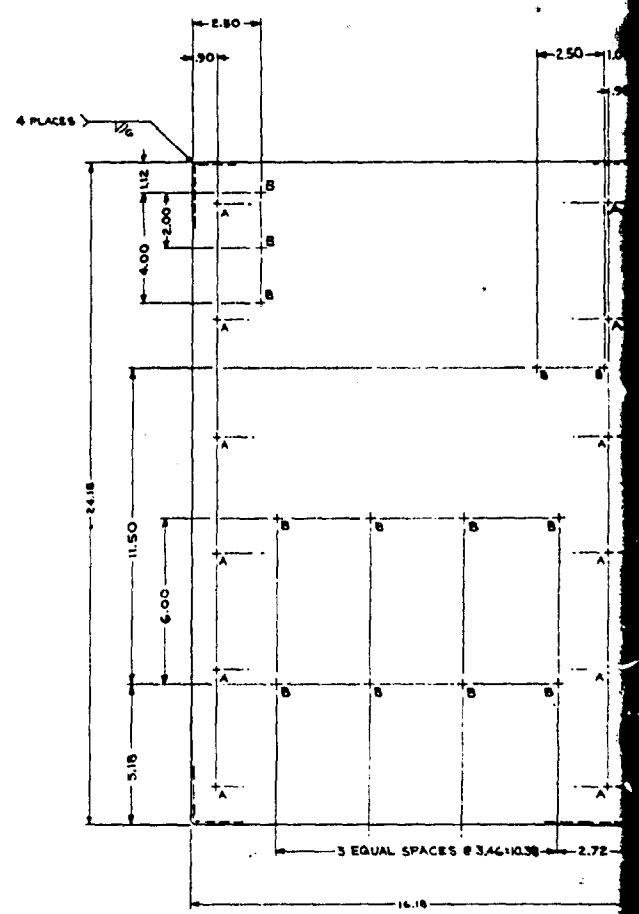
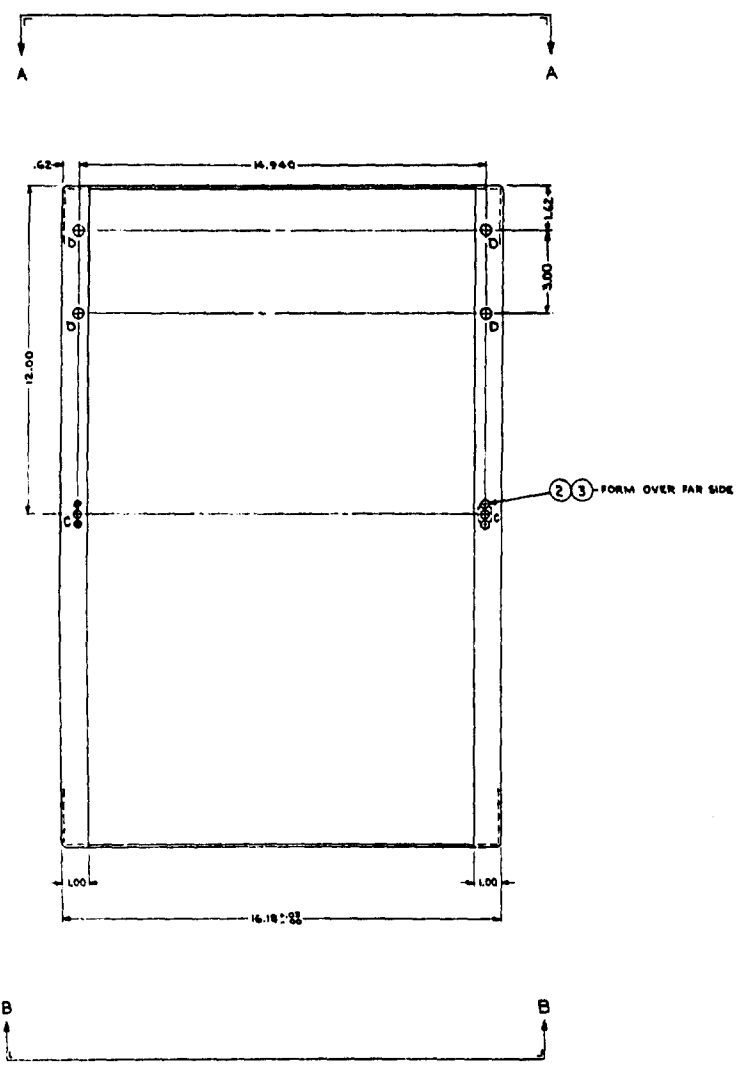

NOTE
ALL HOLES SHOWN IN THIS
VIEW ARE THRU BOTH SIDES

A

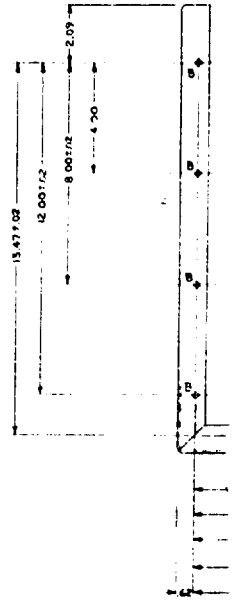
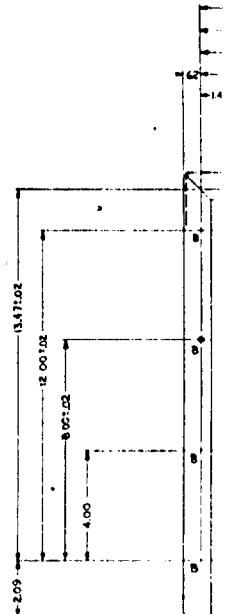
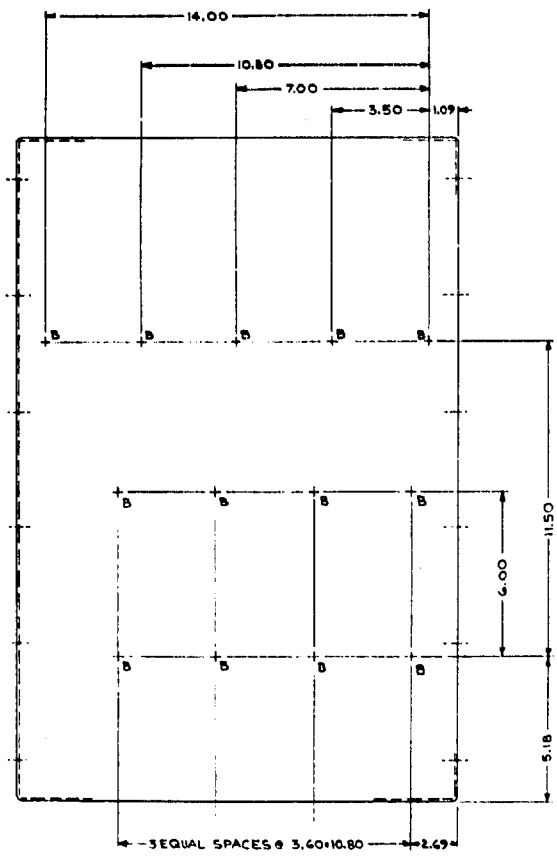
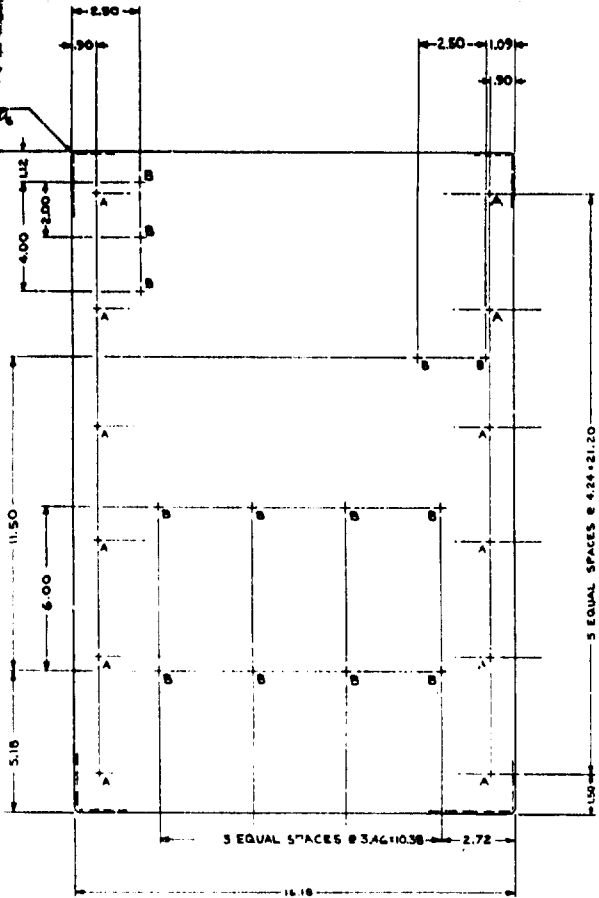

NOTE
ALL HOLES SHOWN IN THIS
VIEW ARE THRU BOTH SIDES

B

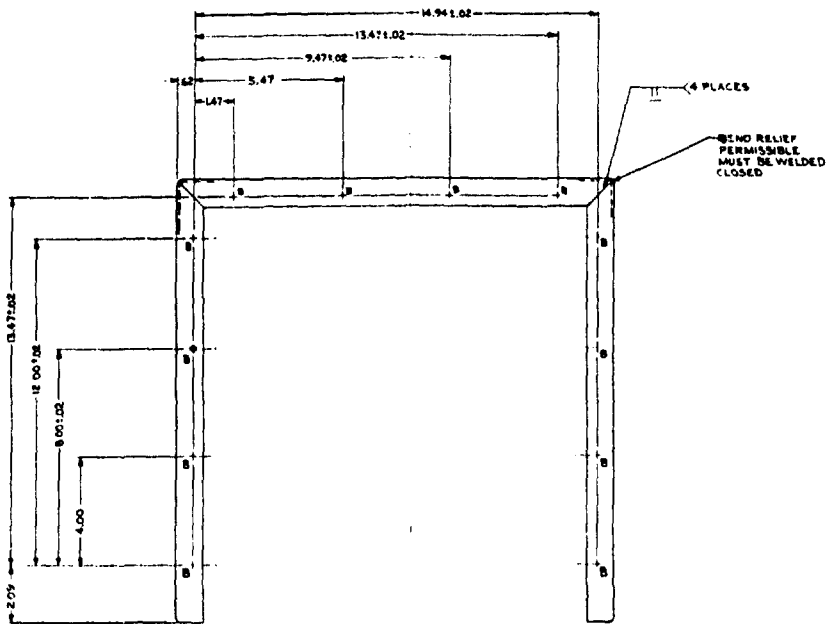

VIEW A-A

| HOLE SCHEDULE | |
|---------------|---------------|
| HOLE | DESCRIPTION |
| A | .257-.247 DIA |
| B | .204-.214 DIA |
| C | SEE DETAIL I |
| D | .370-.380 DIA |

NOTE:
ALL BEND RADI TO BE .09

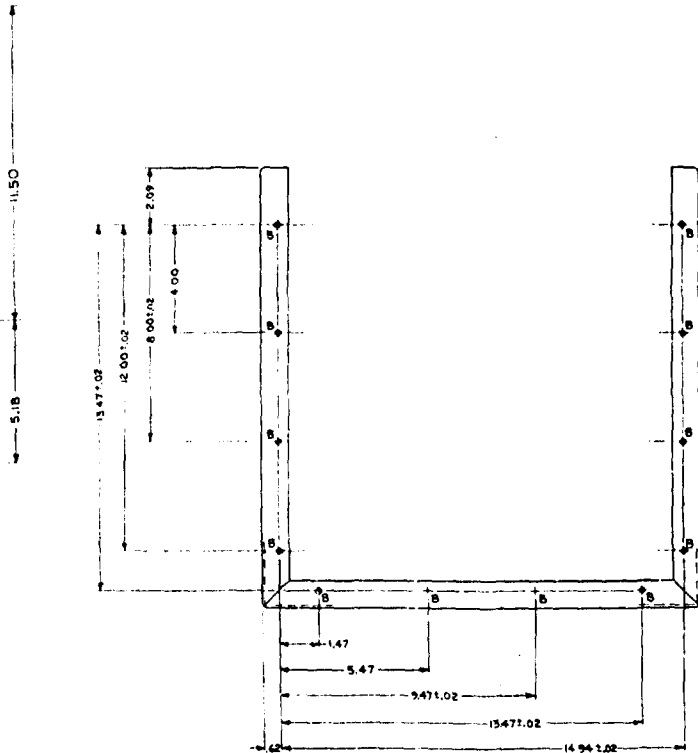

VIEW B-B

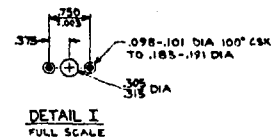

| LIST OF MATERIAL | | | |
|------------------|-----|------|---|
| GROUP | QTY | UNIT | DESCRIPTION |
| 331 | 92 | 61 | 110066H50B RIVET, SOLID ALUM, 100° CSK, NO 3/32DA |
| | 2 | 1 | 2 1/4 LB |
| | 1 | 1 | PARTNER, MINATURE RECEPTACLE (CRES) |
| | 1 | 1 | ALU. A. ALLOY SHEET, CS03TK TYPE |
| | | | EC52-H32 |

FINISH:
ALKALINE DIP (ROUGH ETCHED)
PROXY-WHITE FINISH THEN
APPLY PROTECTIVE COATING
(MILAC 11000 ALLIED RESEARCH
PROP. INC.)

Figure A-11. Box, Inner (J2205180)

A-12

C

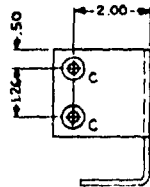

| LIST OF MATERIAL | | | | | |
|------------------|-----|-----------|-------------------------|-----------------------------|---|
| GROUP | QTY | U OF ITEM | PART OR IDENTIFYING NO. | NOMENCLATURE OR DESCRIPTION | |
| 63 | 62 | 61 | M | HC | |
| | | | 70 | 5 | INSTALLATION INSTRUCTIONS P6017 |
| | 2 | 2 | 1 | 4 | 2134247615 NUT, (CLINCH)/ (CRS) |
| | | | 20 | 3 | INSTALLATION INSTRUCTIONS P6016 |
| | 4 | 4 | 1 | 2 | 115120A646 INSERT, THREADED (FLUSH TYPE) |
| | 1 | 1 | 1 | 1 | ALUMINUM, ALLOY, SHEET, .125 THK, TYPE 5052-H32 |

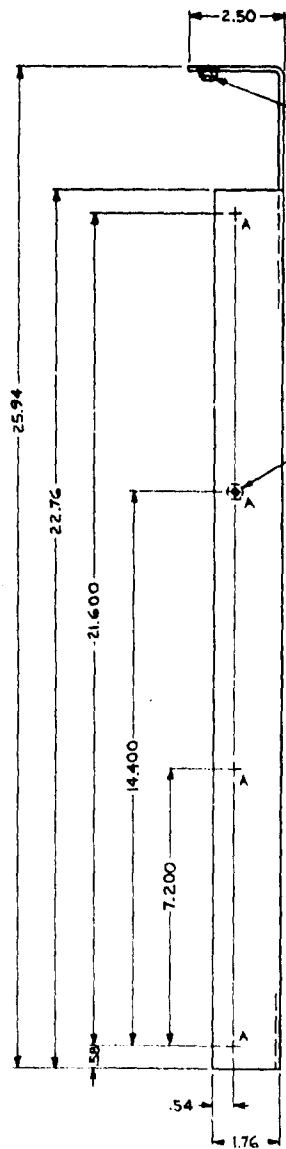

4 - INSTALL IN 'C' HOLES PER ITEM 5

2 - INSTALL IN 'A' HOLES PER ITEM 3 FROM FAR SIDE

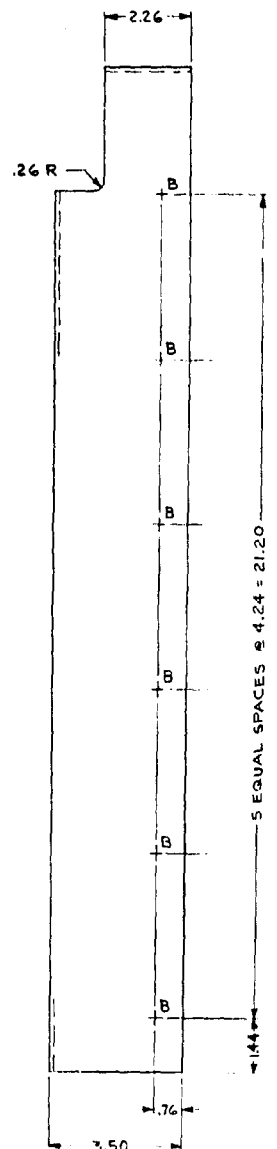

A

| LIST OF MATERIAL | | | | | |
|------------------|-----|-----|------|-------------------------|---|
| GROUP | QTY | UOM | ITEM | PART OR IDENTIFYING NO. | NOMENCLATURE OR DESCRIPTION |
| G3 | G2 | S1 | M | NO. | |
| | | | 20 | 5 | INSTALLATION INSTRUCTIONS P6017 |
| | 2 | 2 | 1 | 4 | 2134247G15 NUT,(CLINCH)/(GRES) |
| | | | 20 | 3 | INSTALLATION INSTRUCTIONS P6016 |
| | 4 | 4 | 1 | 2 | 175120A646 INSERT, THREADED/FLUSH TYPE) |
| | 1 | 1 | 1 | 1 | ALUMINUM, ALLOY, SHEET, .125 THK, TYPE 5052-H32 |

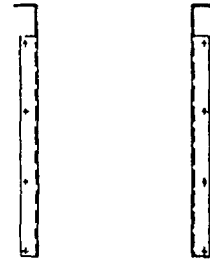

2205181G1 2205181G2

| | |
|-----------|---------------|
| 2205181G1 | AS SHOWN |
| 2205181G2 | OPPOSITE HAND |

| HOLE SCHEDULE | |
|---------------|---|
| HOLE | DESCRIPTION |
| A | .264-.269 DIA |
| B | .237-.247 DIA |
| C | .268-.271 DIA CBORE .563 DIA MIN X .065 DEEP |

NOTE:
ALL BEND RADII TO BE .12

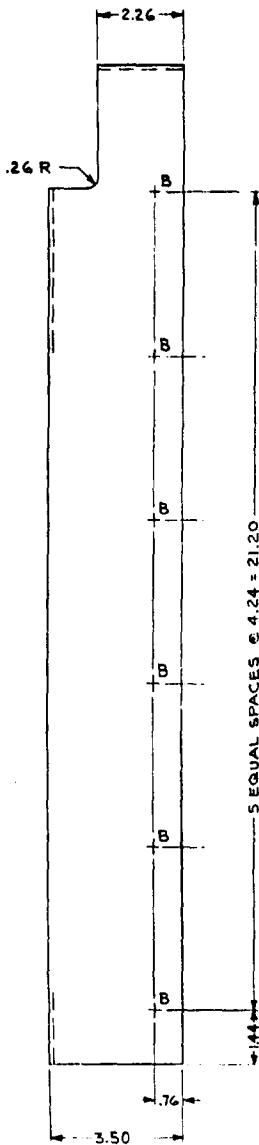

4 - INSTALL IN "C" HOLES PER ITEM 5

2 - INSTALL IN "A" HOLES PER ITEM 3 FROM FAR SIDE

Figure A-12. Angle, Support (D2205181)

A-13

B

(J152)
PI01

+13V

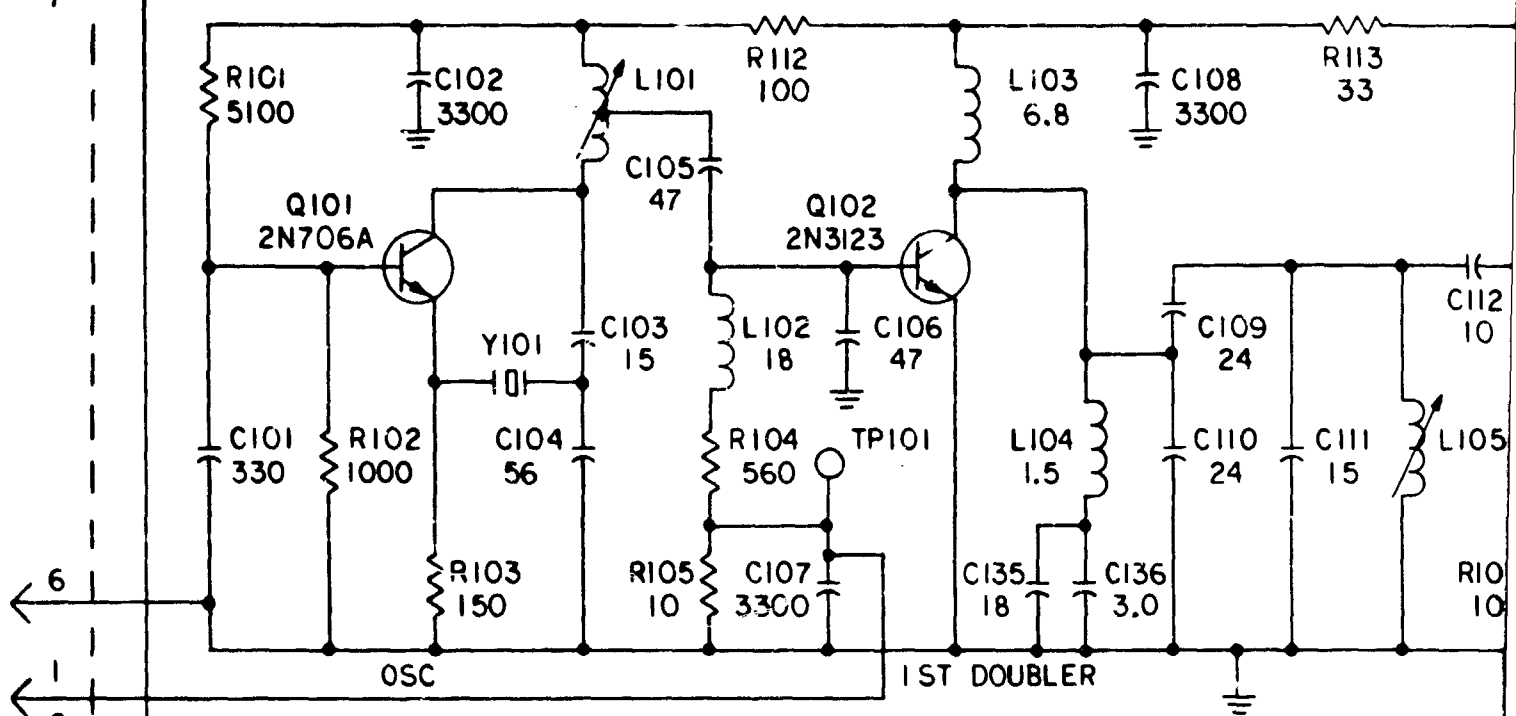

6
1
2
3
4

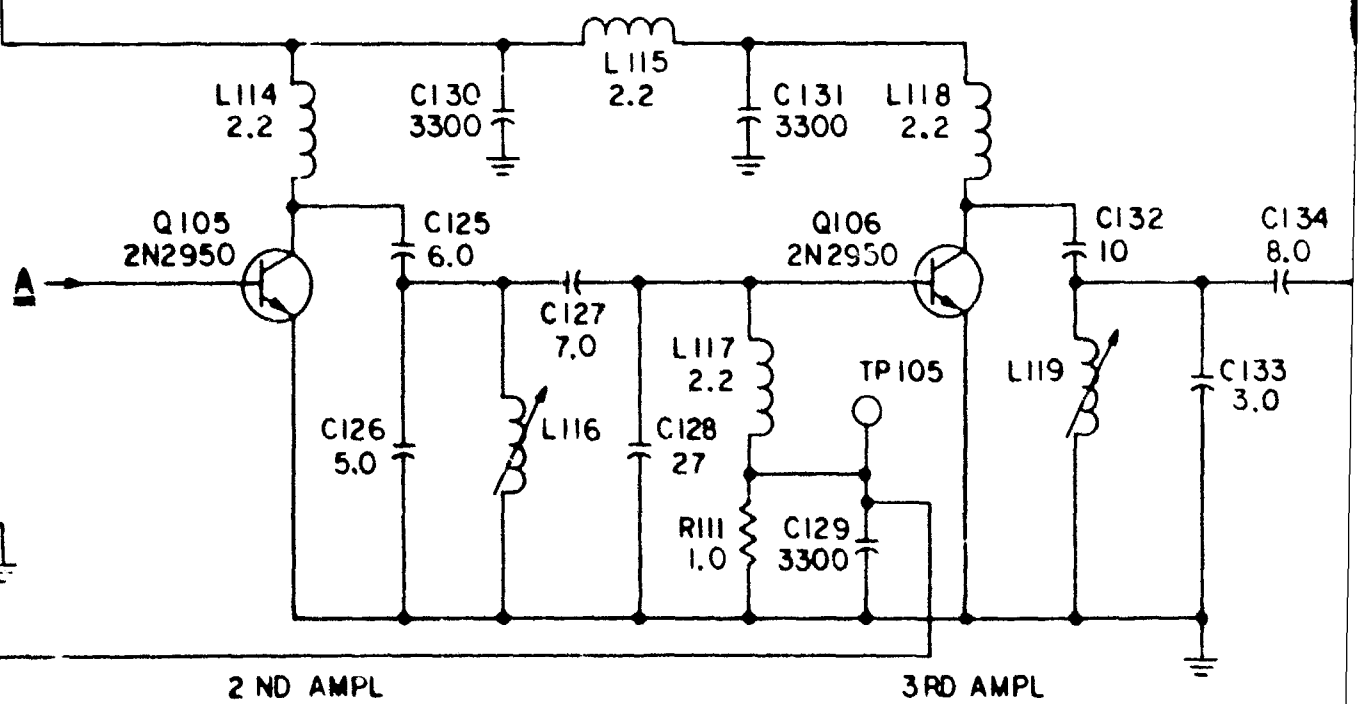

5

A

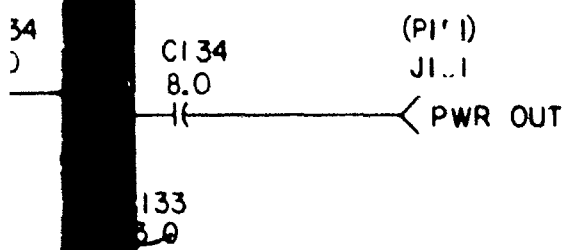
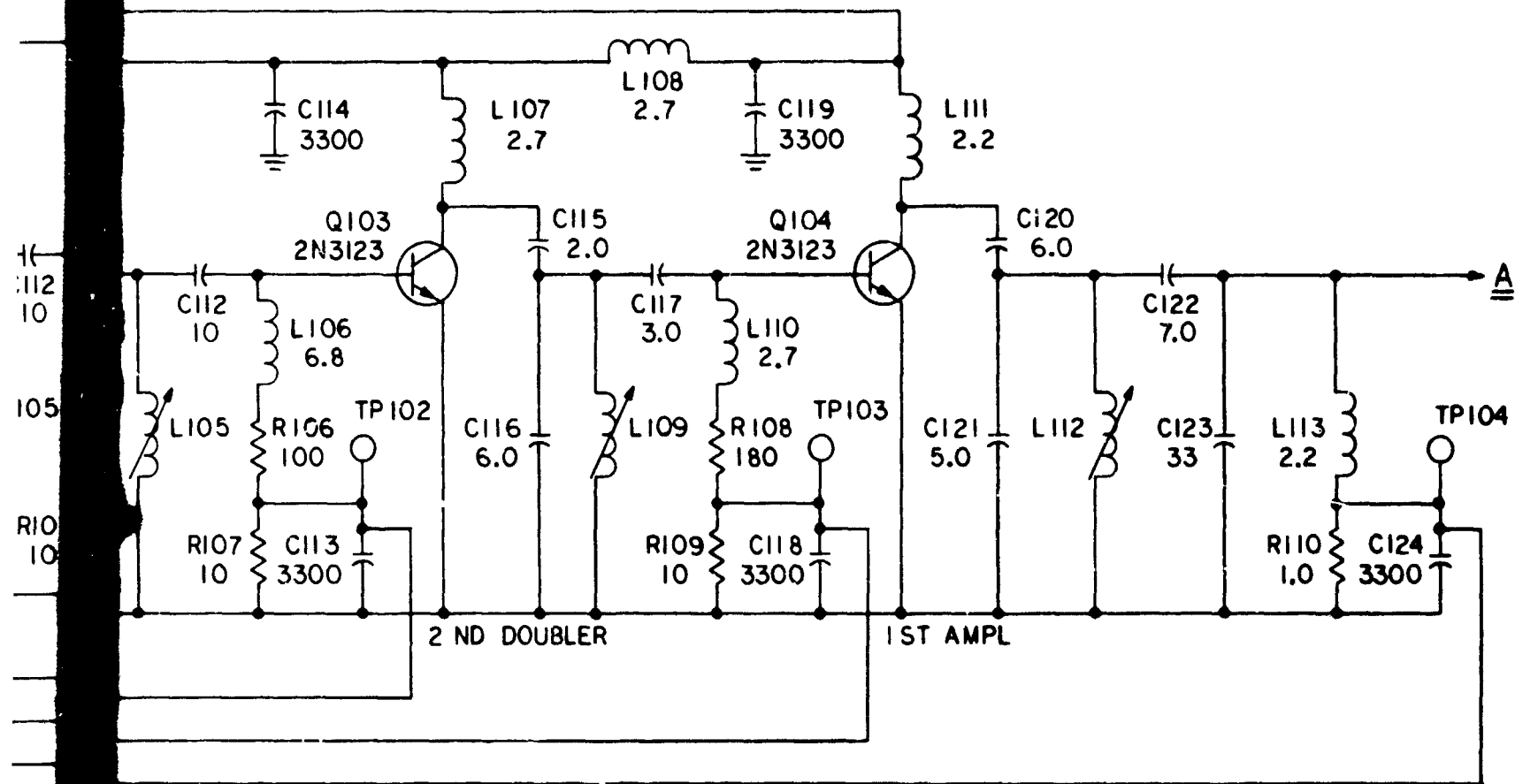

NOTES:
 1. UNLESS OTHERWISE SPECIFIED:
 RESISTANCE VALUES ARE IN OHMS.
 CAPACITANCE VALUES ARE IN PICOFARADS.
 INDUCTANCE VALUES ARE IN MICROMHENRIES.

| HIGHEST REFERENCE DESIGNATIONS | | | | | |
|---------------------------------|------|------|------|-------|--|
| C136 | L119 | Q106 | R113 | TP105 | |
| REFERENCE DESIGNATIONS NOT USED | | | | | |
| | | | | | |

Figure A-13. Schematic Diagram,
 Exciter Glide Slope Transmitter
 (E2205182)

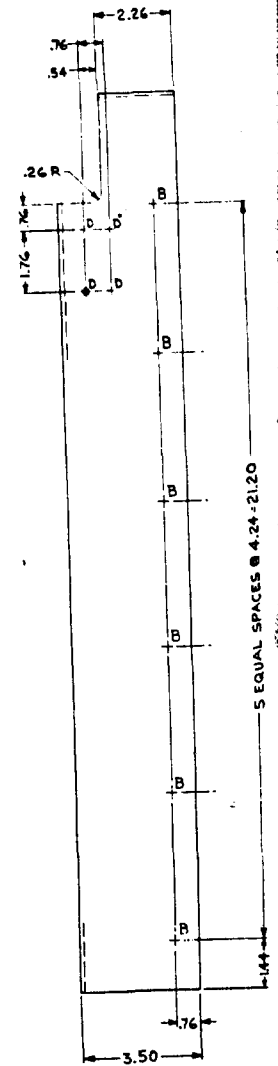
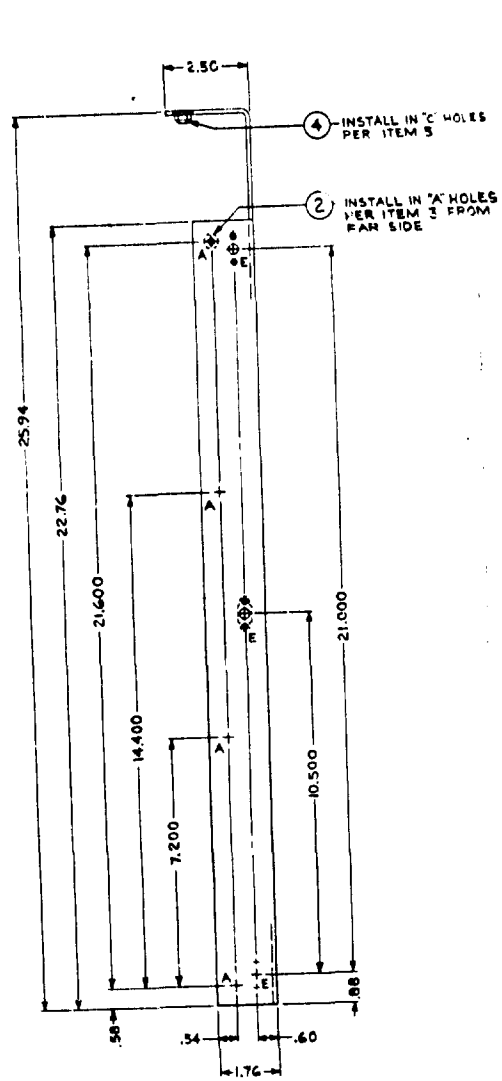
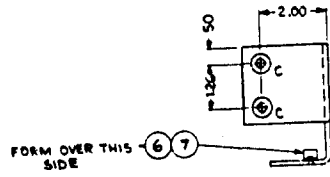

A

INSTALL IN 'C' HOLES
PER ITEM 5

INSTALL IN 'A' HOLES
PER ITEM 3 FROM
FAR SIDE

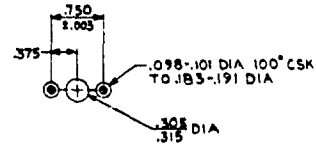
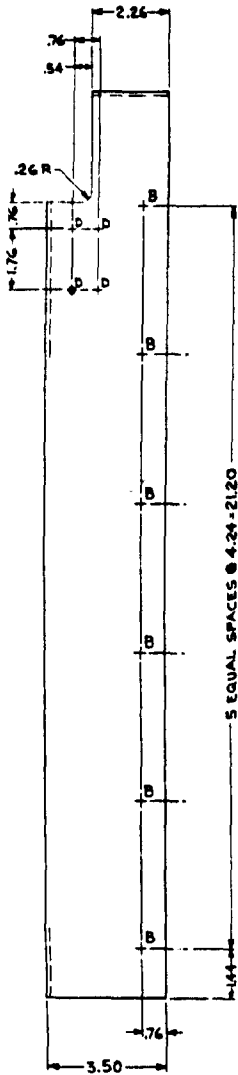

DETAIL I
FULL SCALE

| LIST OF MATERIAL | | | | |
|------------------|-----|-----------|-------------------------|--|
| GROUP | QTY | U OF ITEM | PART OR IDENTIFYING NO. | NOMENCLATURE OR DESCRIPTION |
| G3 | 2 | M | 110065H510 | RIVET SOLID ALUMINUM, 100° CSK HD #32 DIA X 5/16 LG. |
| | 3 | M | 315495 | FASTENER MINIATURE RECEPTACLE |
| | 20 | S | | INSTALLATION INSTRUCTIONS PG017 |
| | 4 | M | 175120A646 | INSERT, THREADED (FLUSH TYPE) |
| | 1 | M | | ALUMINUM, ALLOY, SHEET, .125 THK, TYPE 5052-H32 |

| HOLE SCHEDULE | |
|---------------|---|
| HOLE | DESCRIPTION |
| A | .264-.269 DIA |
| B | .237-.247 DIA |
| C | .268-.271 DIA CBDRIVE .563 DIA MIN X .065 DEEP |
| D | .204-.214 DIA |
| E | SEE DETAIL I |

NOTE:
ALL BEND RADII TO EE .12

FINISH:
ALKALINE DIP (ROUGH ETCHED FROSTY-WHITE FINISH) THEN APPLY PROTECTIVE COATING (IRILAC® 1000 ALLIED RESEARCH PROD. INC.)
*IN PART NO. COL. DENOTES VENDOR ITEM. SEE SOURCE CONTROL OR SPECIFICATION CONTROL DRAWING.

Figure A-16. Angle, Support
(D2205185)

A-17

B

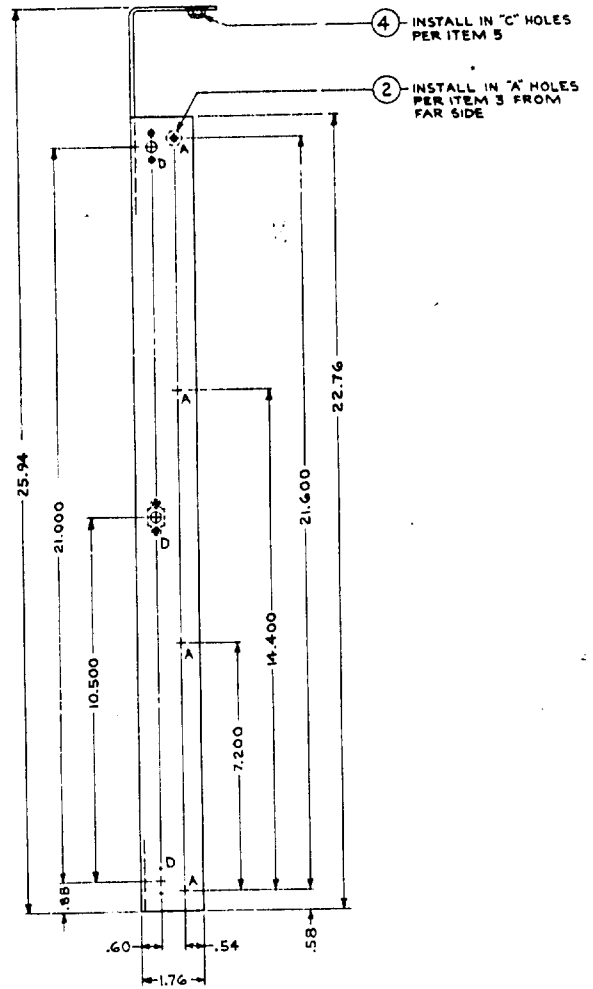
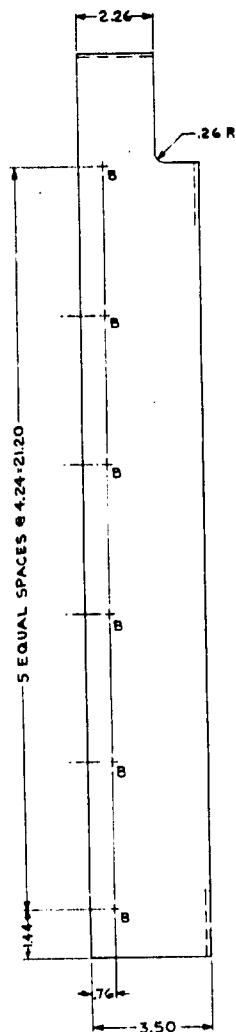
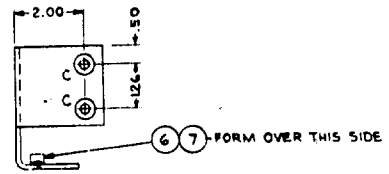

A

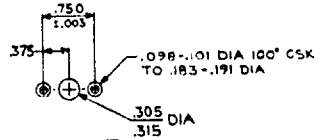
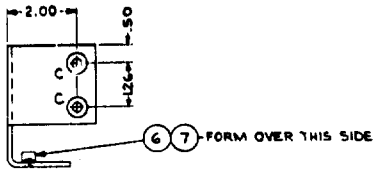

DETAIL I
FULL SCALE

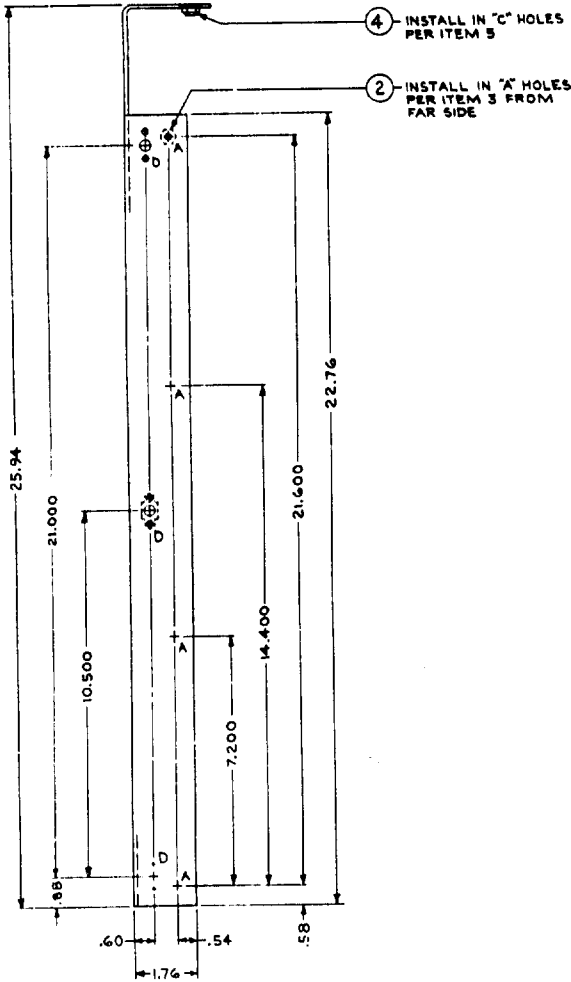

| HOLE SCHEDULE | |
|---------------|---|
| HOLE | DESCRIPTION |
| A | .264-.269 DIA |
| B | .237-.247 DIA |
| C | .268-.271 DIA CBORE .563 DIA MIN X .045 DEEP |
| D | SEE DETAIL I |

NOTE:
ALL BEND RADII TO BE .12

FINISH:
ALKALINE DIP (ROUGH ETCHED FROSTY-WHITE FINISH) THEN APPLY PROTECTIVE COATING (IRILAC #1000 ALLIED RESEARCH PROP. INC.)

Figure A-17. Angle, Support (D2205186)

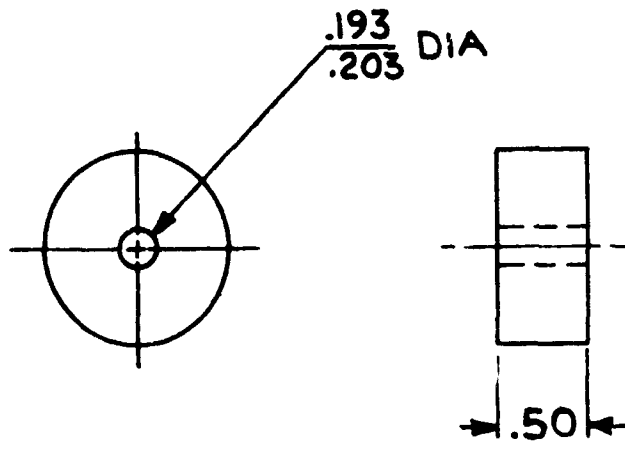

| LIST OF MATERIAL |
|---|
| PLASTIC, PHEN, LAM, NAT, ROD, 1" DIA, GRADE LE PER MIL-P-79 FBE |

Figure A-18. Spacer (B2205187)

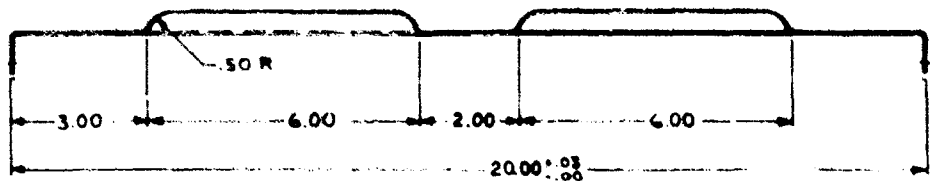
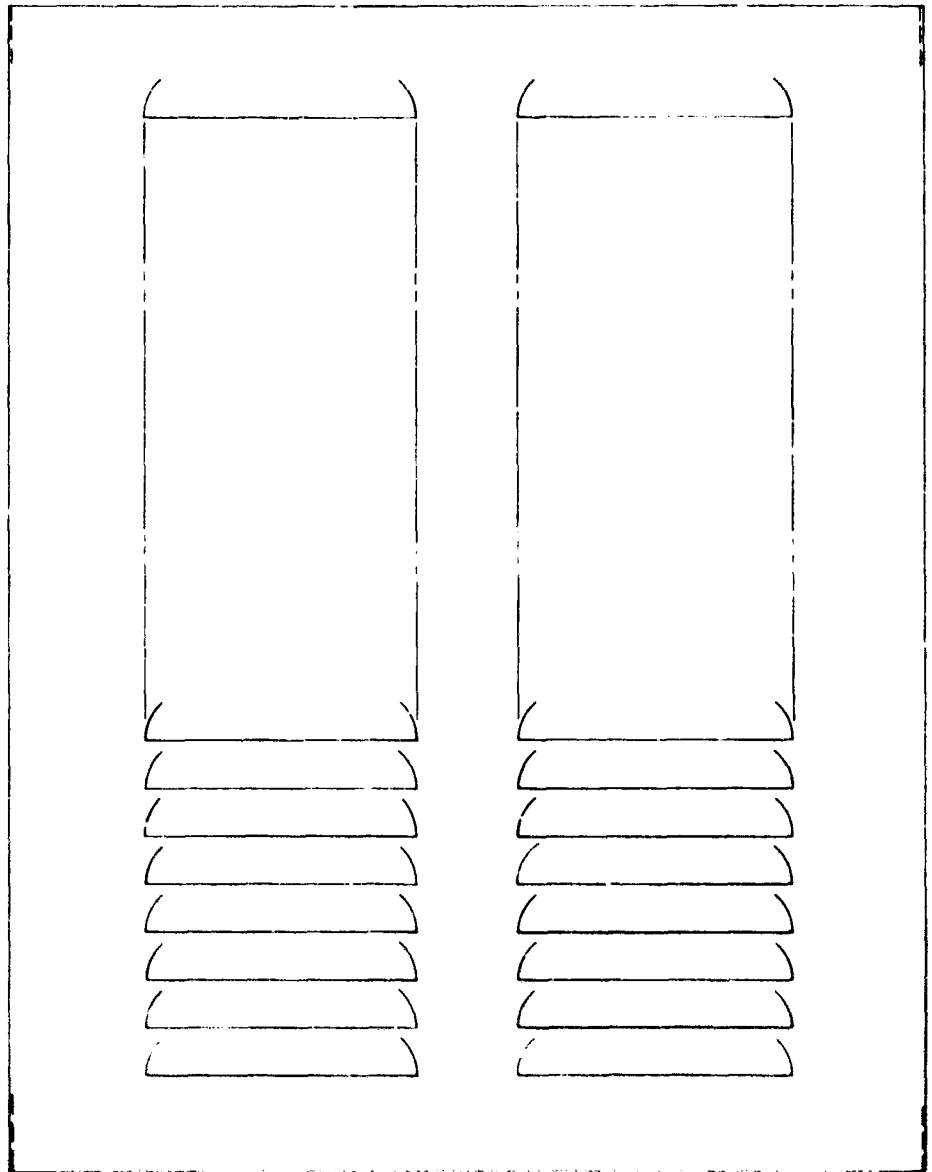

LIST OF MATERIAL
 ALUMINIUM ALLOY SHEET
 .063 THK, TYPE 5052-H32

NOTE:
 ALL BEND RADII TO BE .0

A

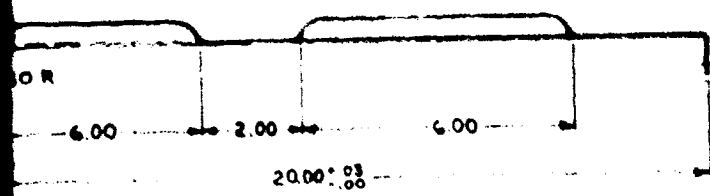
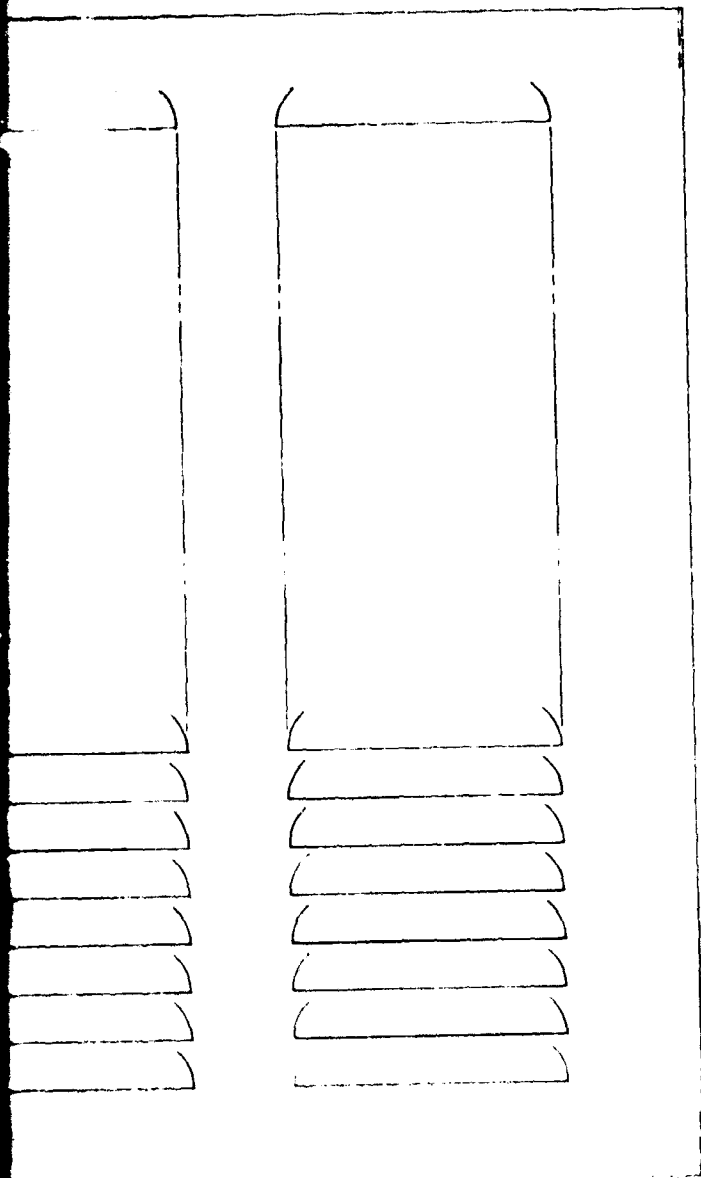

OF MATERIAL
 ALUMINUM ALLOY SHEET,
 TYPE 5052-H32

NOTE:
 ALL BEND RADII TO BE .06

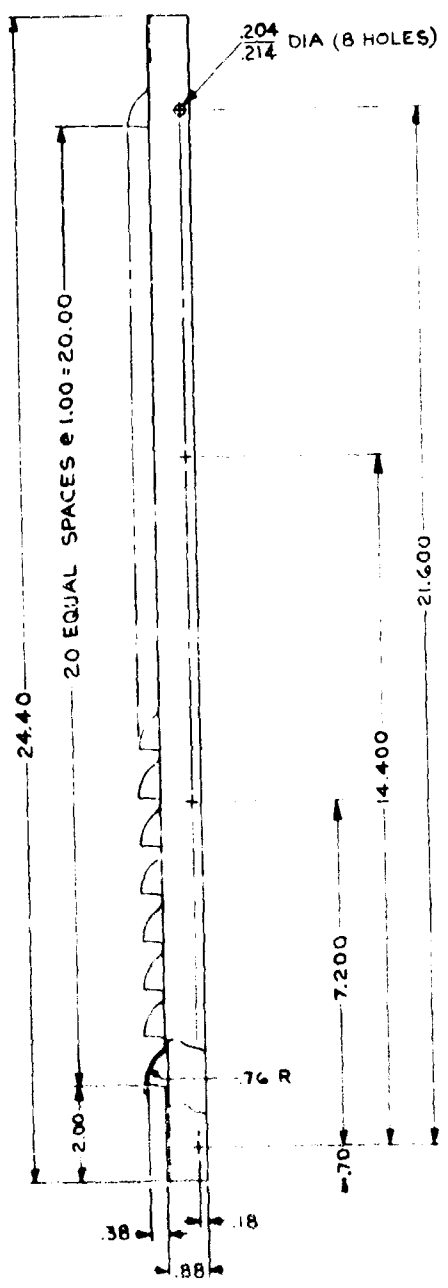
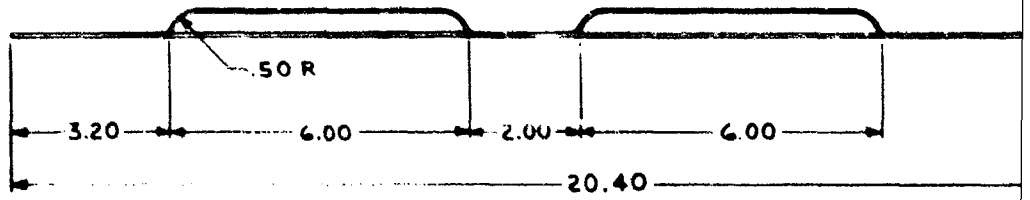
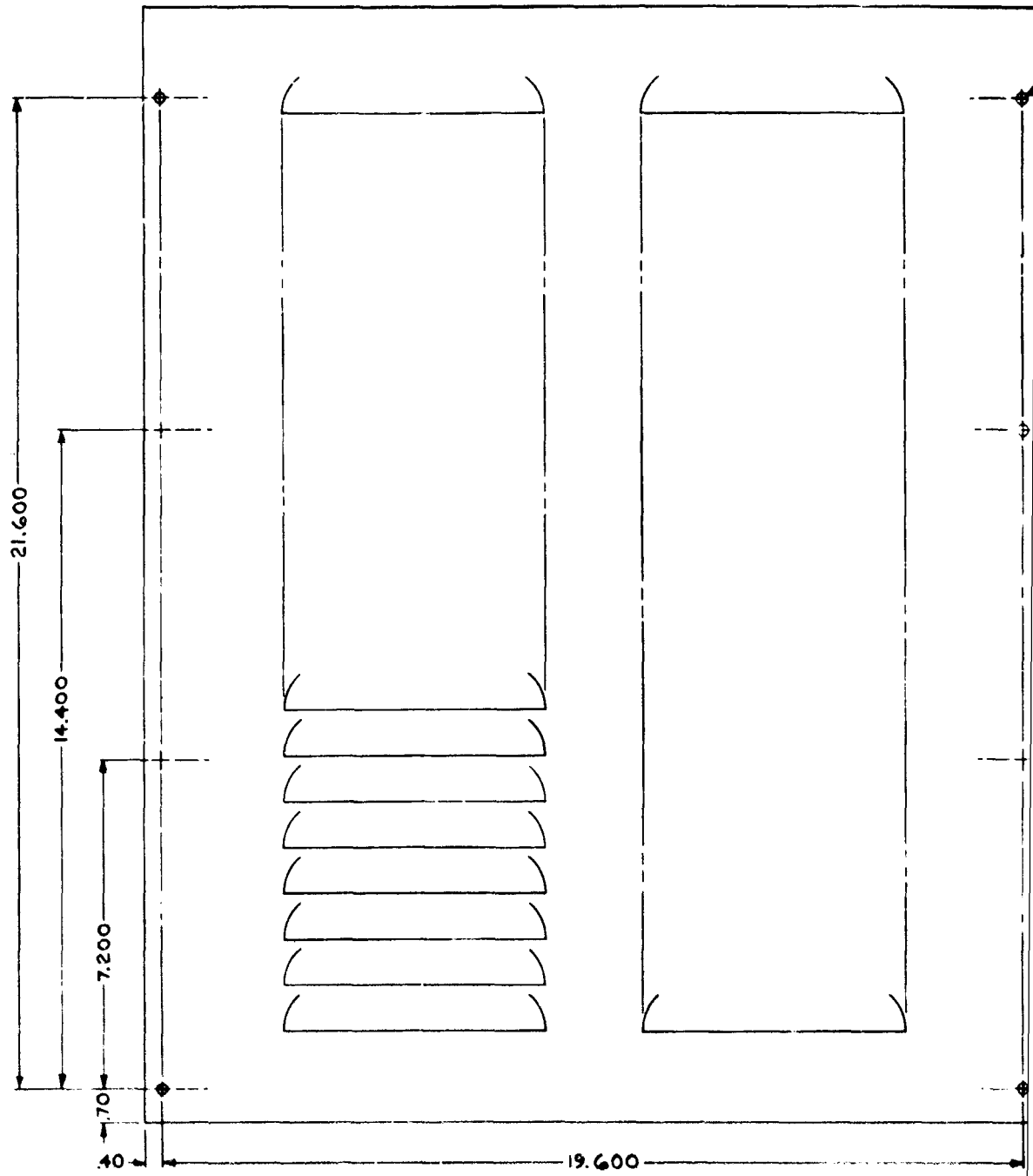

Figure A-19. Outer Panel (Side)
 (D2205189)

A-20

B



A

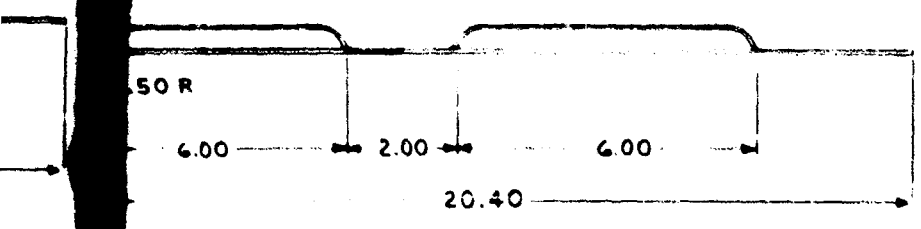
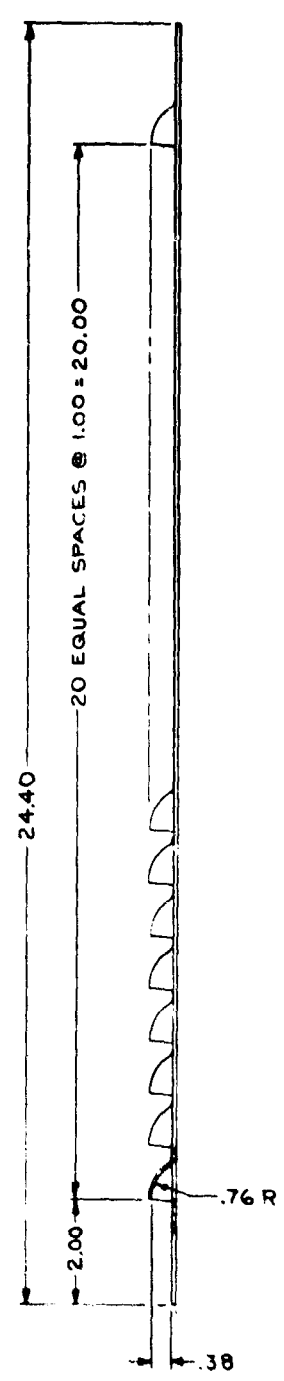
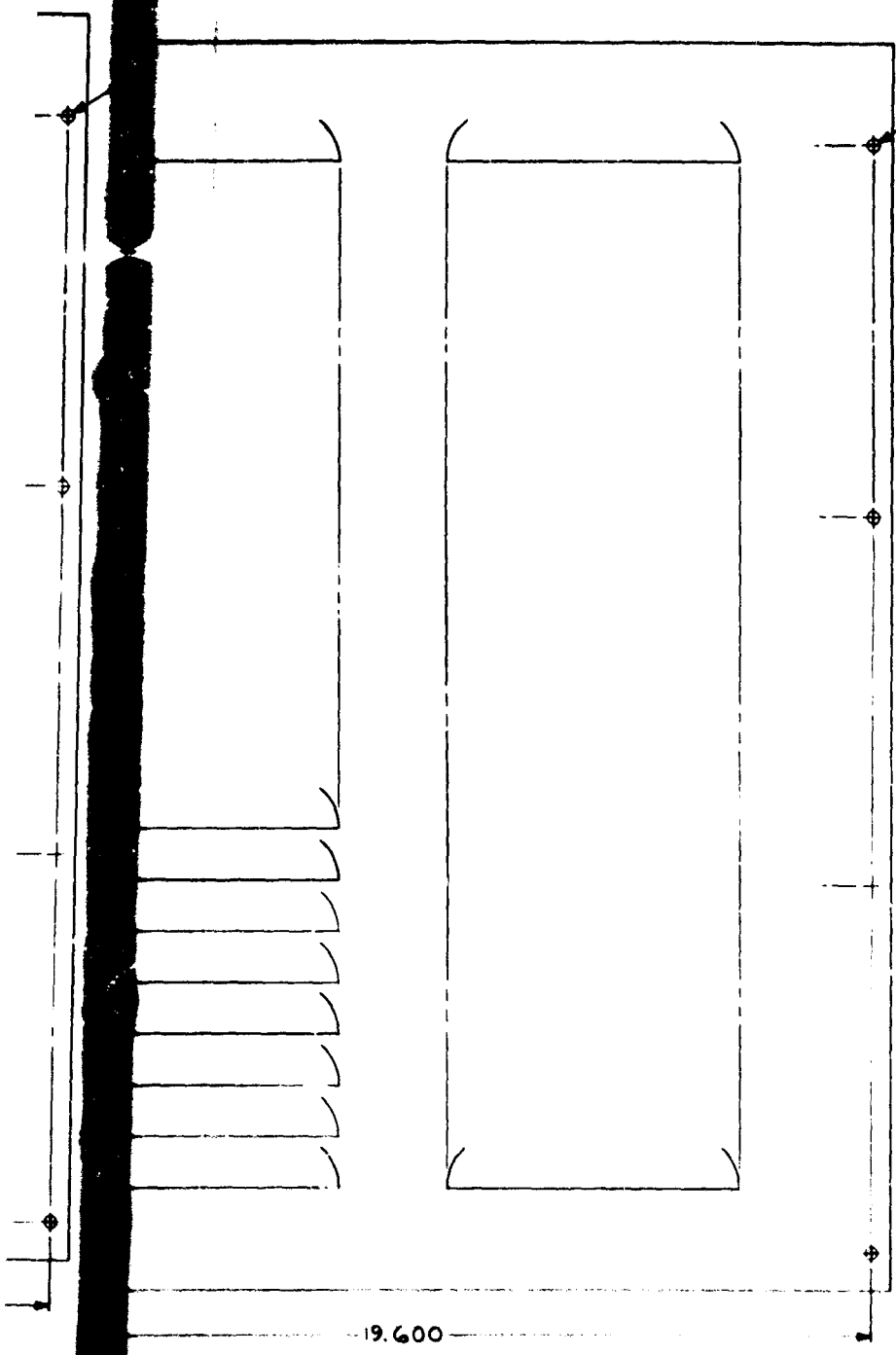

| |
|-----------------------------|
| LIST OF MATERIAL |
| ALUMINUM, ALLOY, SHEET .003 |
| THK, TYPE 5052-H32 |

Figure A-20. Outer Panel (Back)
(D2205190)

A-21

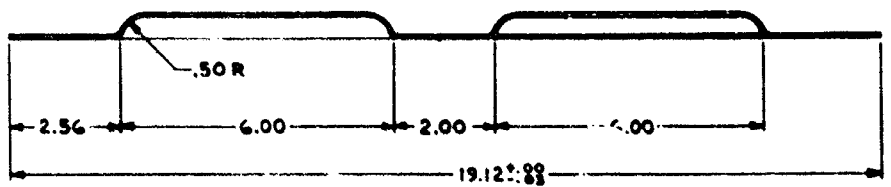
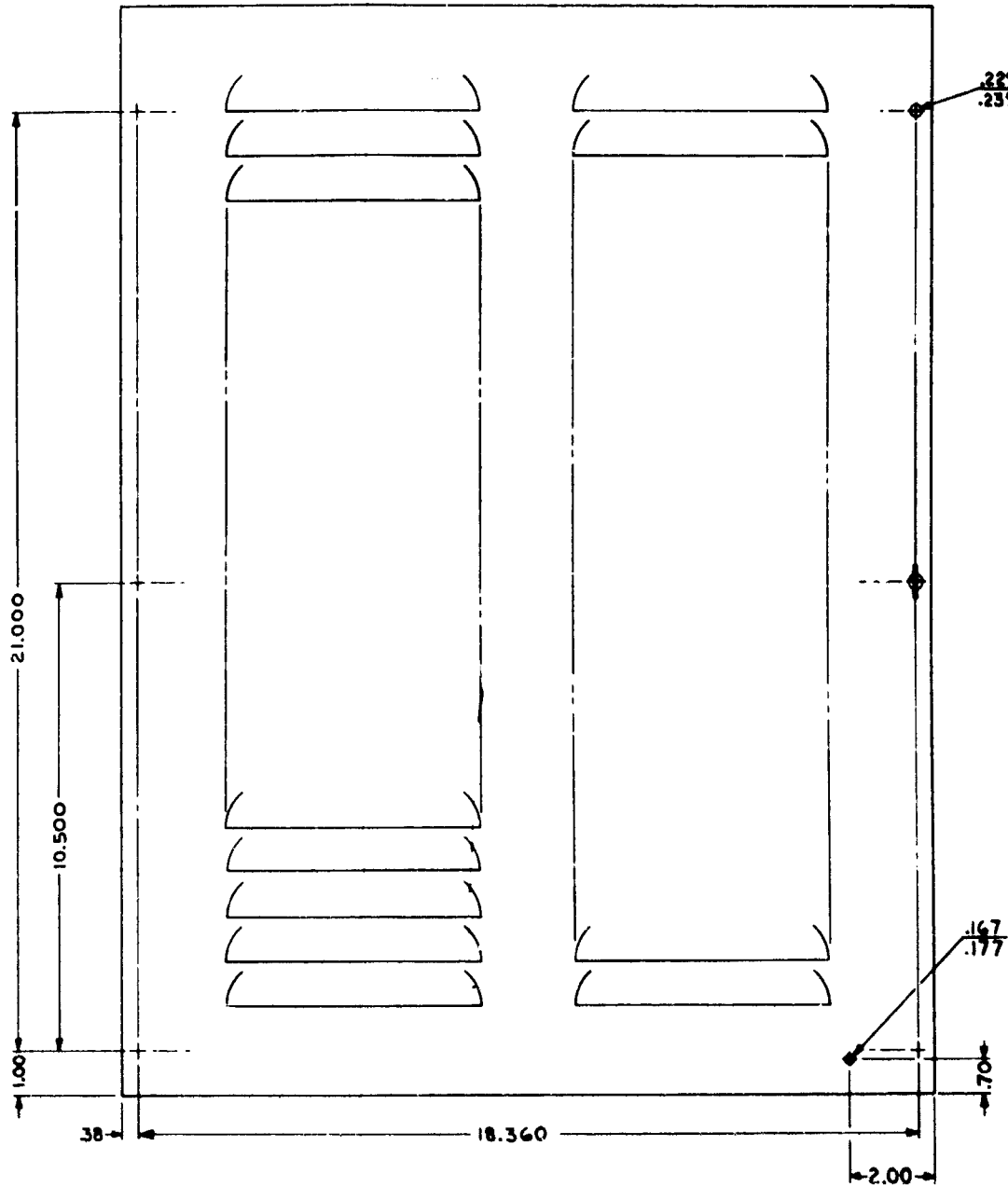

LIST OF MATERIAL

| GROUP | QTY | U OF ITEM | PART OR IDENTIFYING NO. | NOMENCLATURE OR DESCRIPTION | |
|-------|-----|-----------|-------------------------|-----------------------------|---|
| G3 | G2 | G1 | M NO. | | |
| | 6 | 1 | 3 | 315494 | RETAINER (CR6) |
| | 6 | 1 | 2 | 315073A110 | FASTENER MINIATURE STUD (CR6) |
| | 1 | 1 | 1 | | ALUMINUM, ALLOY, SHEET, .003 THK, TYPE 5052-H32 |

A

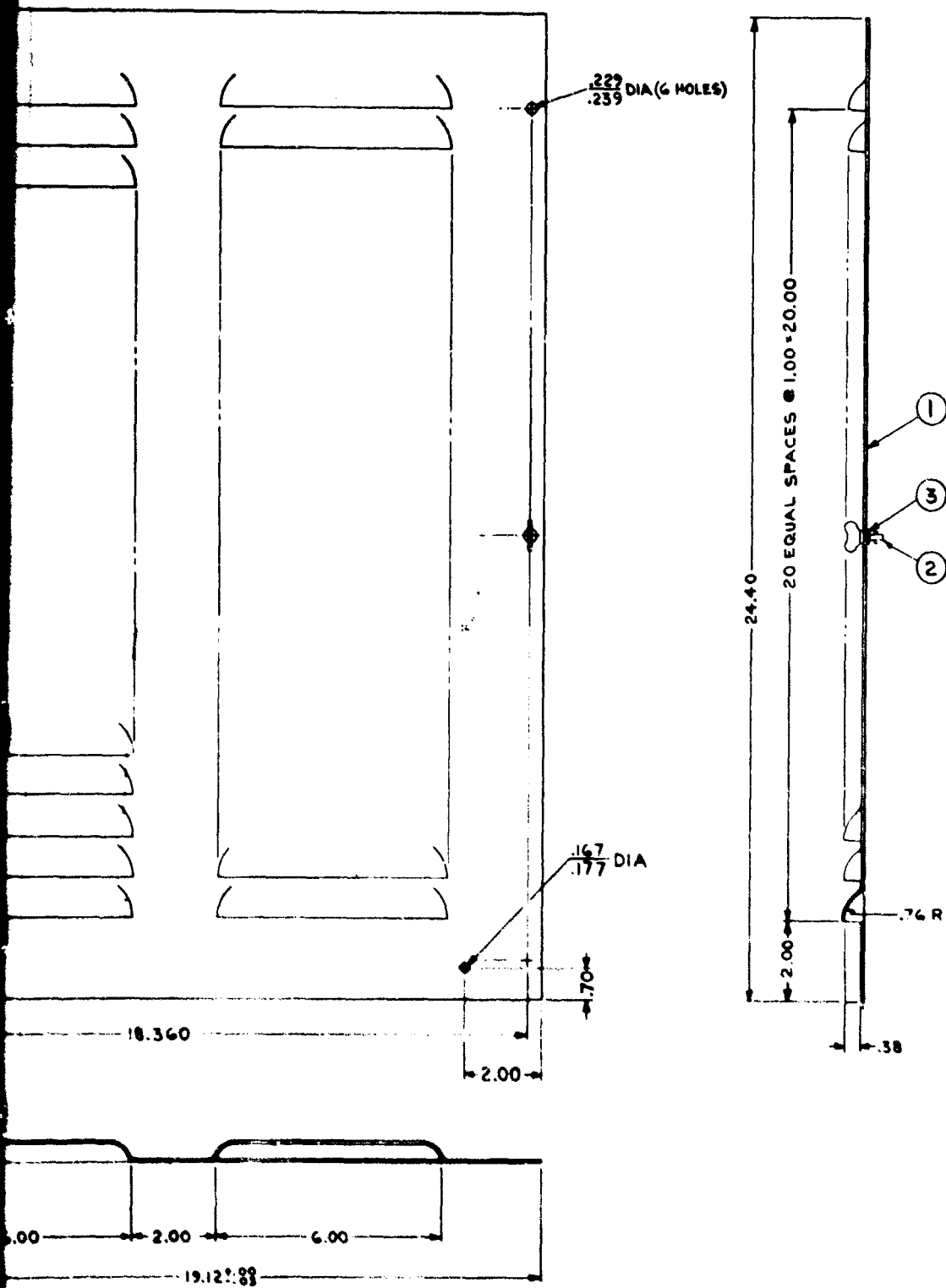

| LIST OF MATERIAL | |
|-------------------------|--|
| PART OR IDENTIFYING NO. | NOMENCLATURE OR DESCRIPTION |
| 315454 | RETAINER (CRE) |
| 315073 A110 | FASTENER MINIATURE STUD (CRE) |
| | ALUMINUM, ALLOY, SHEET, .003 THK, TYPE |
| | 5052-H32 |

Figure A-21. Outer Panel (Front)
(D2205191)

A-22

B

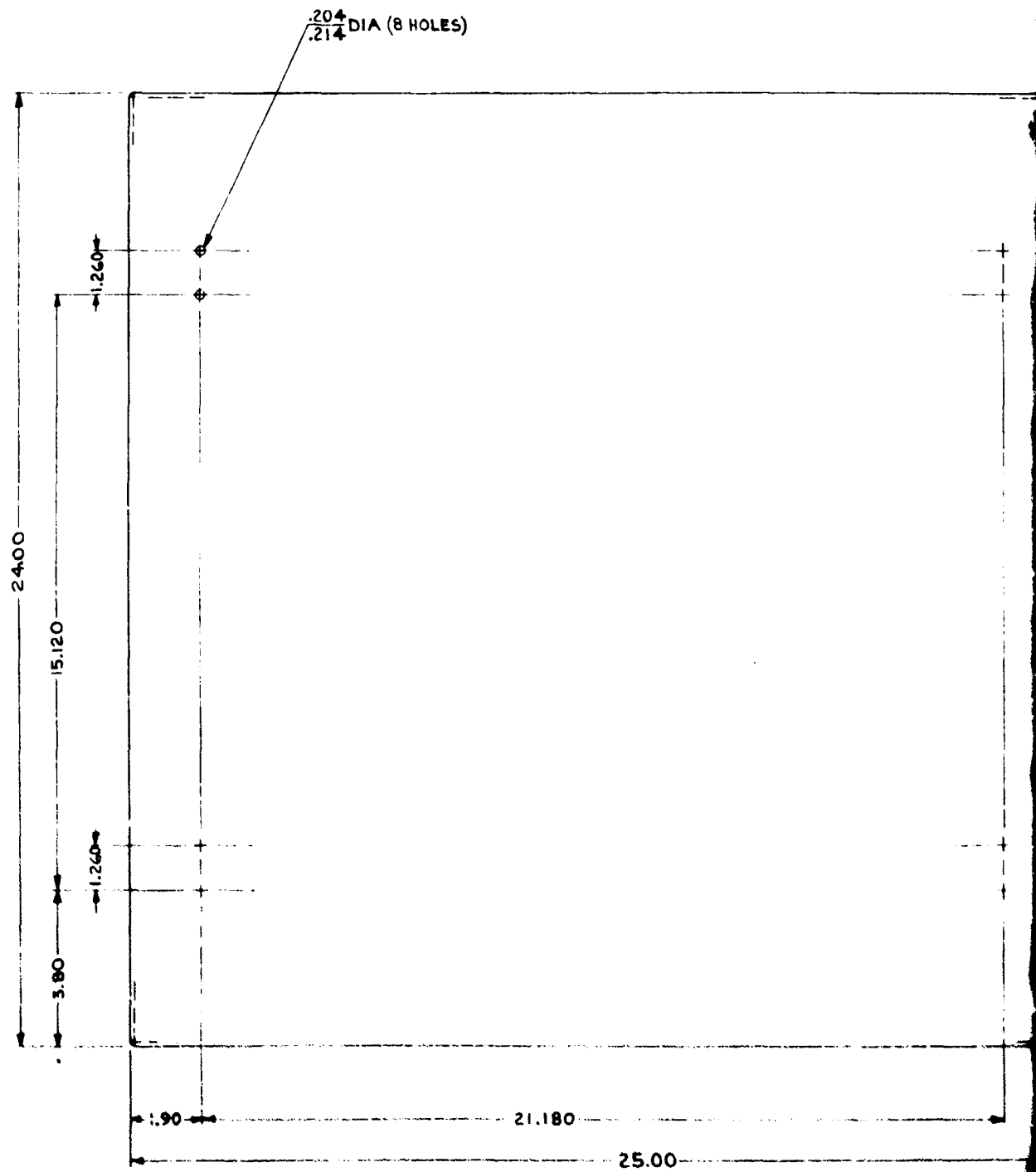

| |
|---|
| <p>LIST OF MATERIAL ALUMINUM, ALLOY, SHEET, .090 THK, TYPE 5052-H32</p> |
|---|

NOTE:
 ALL BEND RADI TO BE .09

A

F

DIA (8 HOLES)

BEND RELIEF PERMISSIBLE
MUST BE WELDED CLOSED

R_G (4 CORNERS)

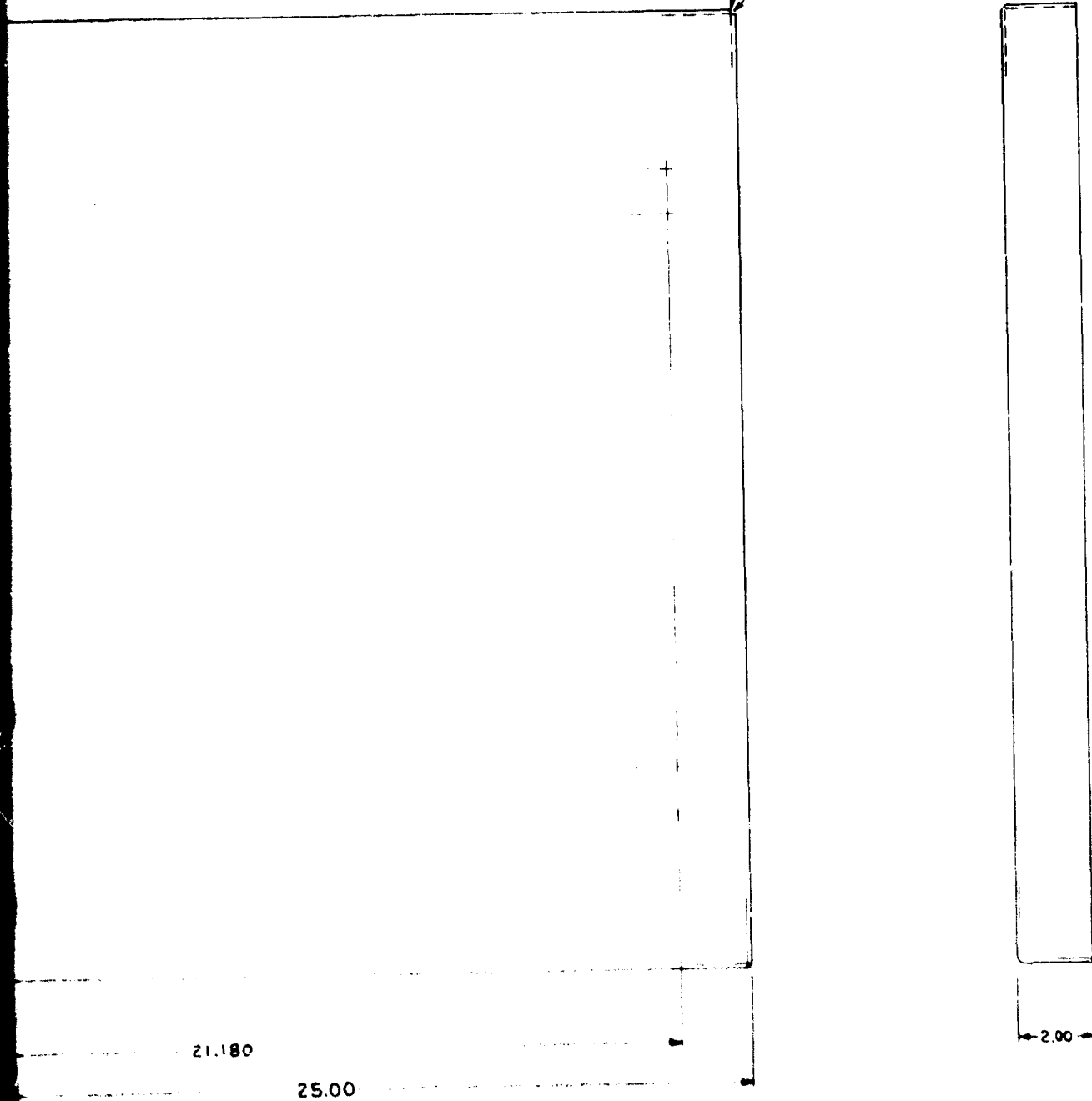

LIST OF MATERIAL
ALUMINUM, ALLOY, SHEET,
.090 THK. TYPE 5052 H32

NOTE
ALL BEND RADI TO BE .09

Figure A-22. Cover, Top (D2205192)

A-23

B

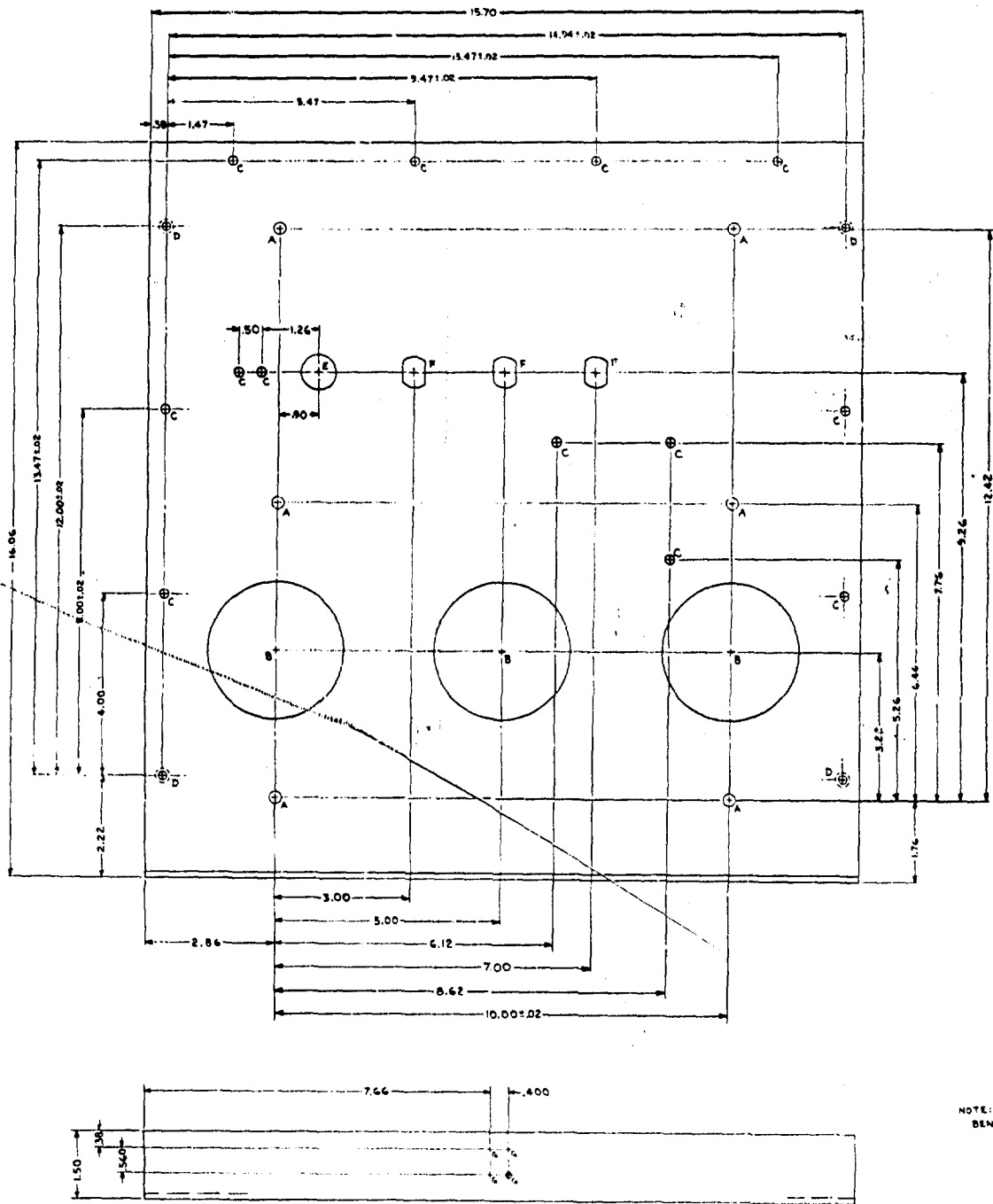

Fi

A

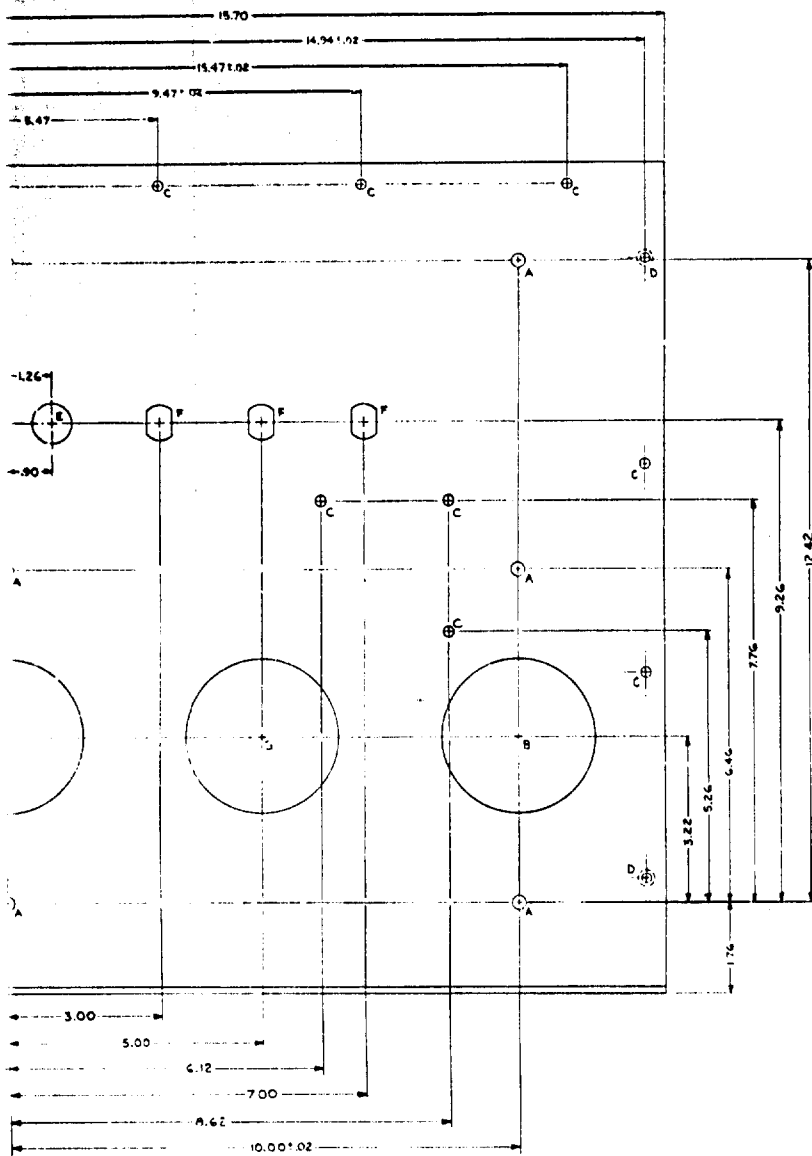

| HOLE | DESCRIPTION |
|------|---|
| A | .237-.247 DIA |
| B | 2.760-3.040 DIA |
| C | 2.204-2.14 DIA |
| D | .167-.177 DIA 100° CSK TO 2.78-.301 DIA FAR SIDE |
| E | .771-.791 DIA |
| F | DF-0650 |
| G | .135-.145 DIA |

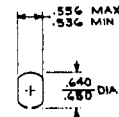

DF-0650
F

| LIST OF MATERIAL |
|---|
| ALUMINUM, ALLOY, SHEET, .125 THK TYPE 3003-M32 |

FINISH:
ALKALINE DIP (ROUGH ETCHED PROSTY-
WHITE FINISH) THEN APPLY PROTECTIVE
COATING (IRILAC 11000 ALLIED RESEARCH
PROP. INC.)

NOTE:
BEND RADIUS TO BE .12

Figure A-23. Plate, Bottom (E2205193)

A-24

B

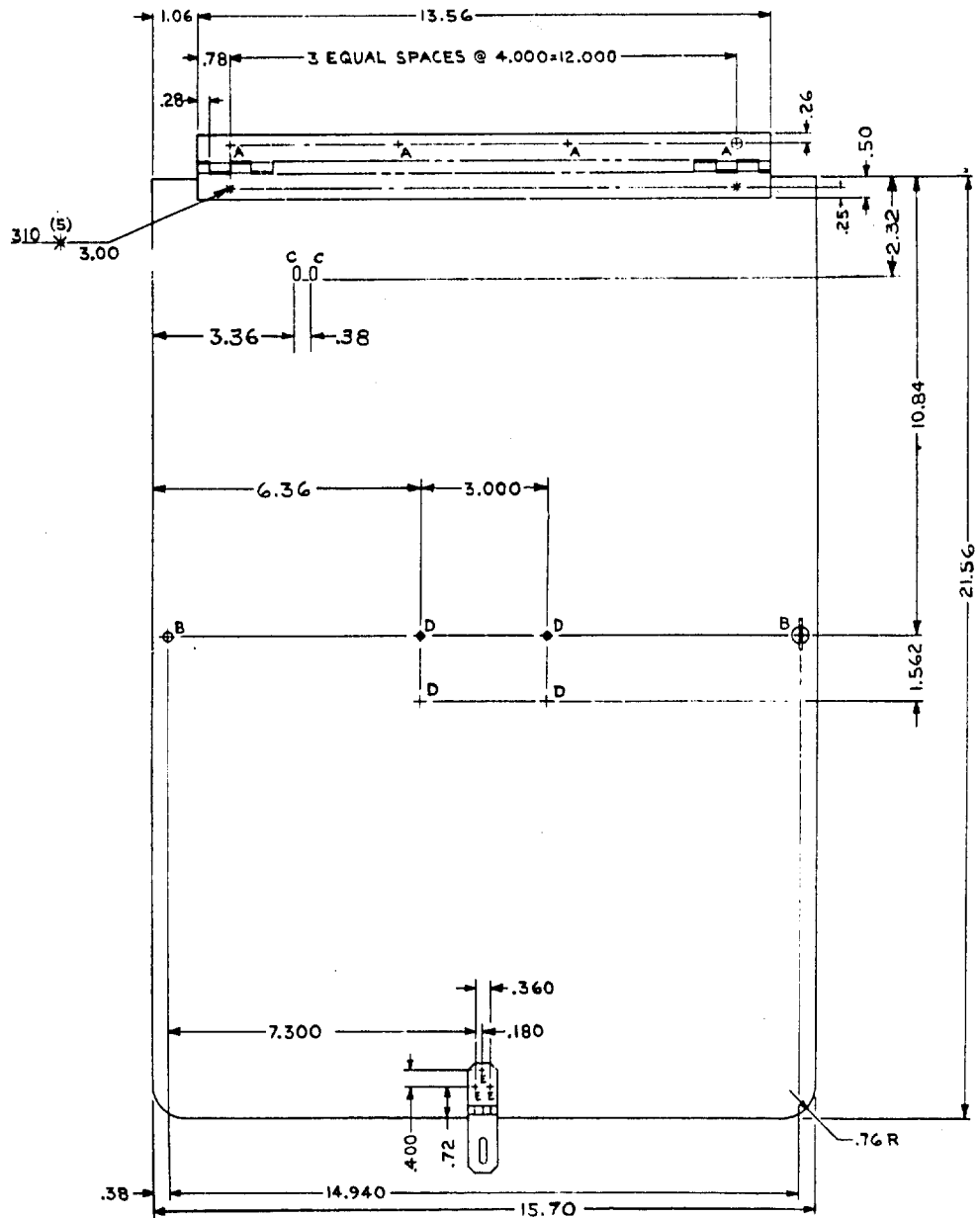

LIST OF MATERIAL

| GROUP | QTY | U OF | ITEM | PART OR | NOMENCLATURE OR DESCRIPTION |
|-------|-----|------|------|------------|---|
| G3 | G2 | G1 | M | NO. | IDENTIFYING NO. |
| | 3 | 1 | 7 | 110105H614 | RIVET, SOLID, ALUM, UNIVERSAL HD 5/32 DIA X 7/16 LG |
| | 1 | 1 | 6 | 2367335G1 | SHIM |
| | 1 | 1 | 5 | | HASP, HINGE (CORBIN CAB. LOCK D.V. #03004) |
| | 2 | 1 | 4 | 315494 | RETAINER (CRES) |
| | 2 | 1 | 3 | 315073A11B | FASTENER, MINIATURE STUD (CRES) |
| | 1 | 1 | 2 | MS 20257-4 | HINGE, CONTINUOUS |
| | 1 | 1 | 1 | | ALUMINUM, ALLOY, SHEET, .090 THK, TYPE 5052-H32 |

A

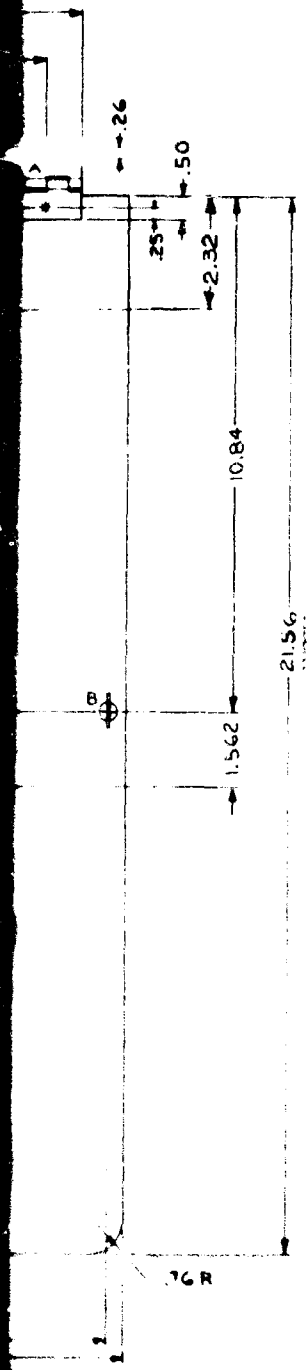

| ITEM | DESCRIPTION |
|------|-------------------------------------|
| 1 | UNIVERSAL NO. 312 DIA. X 1/16" L.G. |
| 2 | IN CAB. LOCK DIV #03004 |
| 3 | URE STUD (CRES) |
| 4 | ST. 0.90 THK, 1/4" DIA. X 1/2" L.G. |

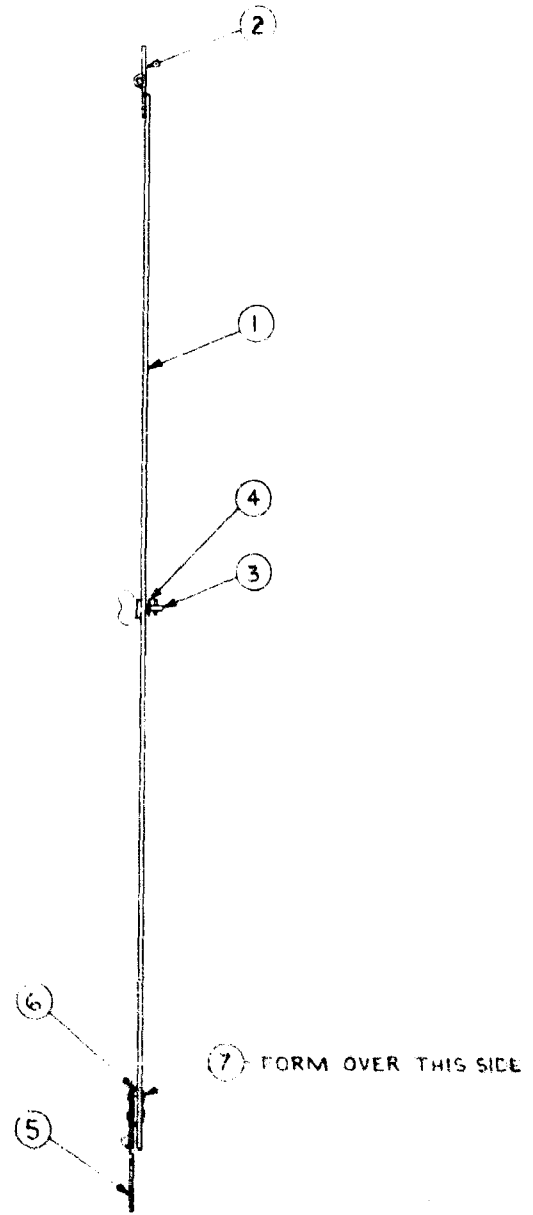

| HOLE | DESCRIPTION |
|------|-----------------|
| A | .204 - .214 DIA |
| B | .229 - .239 DIA |
| C | SEE DETAIL I |
| D | .135 - .145 DIA |
| E | .161 - .165 DIA |

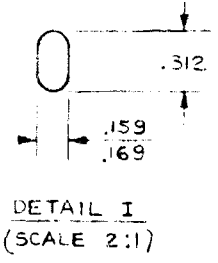

FINISH:
 ALKALINE DIP (ROUGH ETCHED FROSTY-WHITE FINISH) THEN APPLY PROTECTIVE COATING (IRILAC #1000 ALLIED RESEARCH PROP, INC)

Figure A-24, Door, Inner (D2205194)

A-25

B

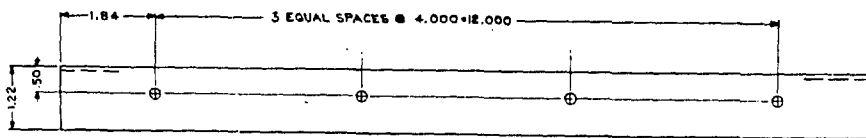
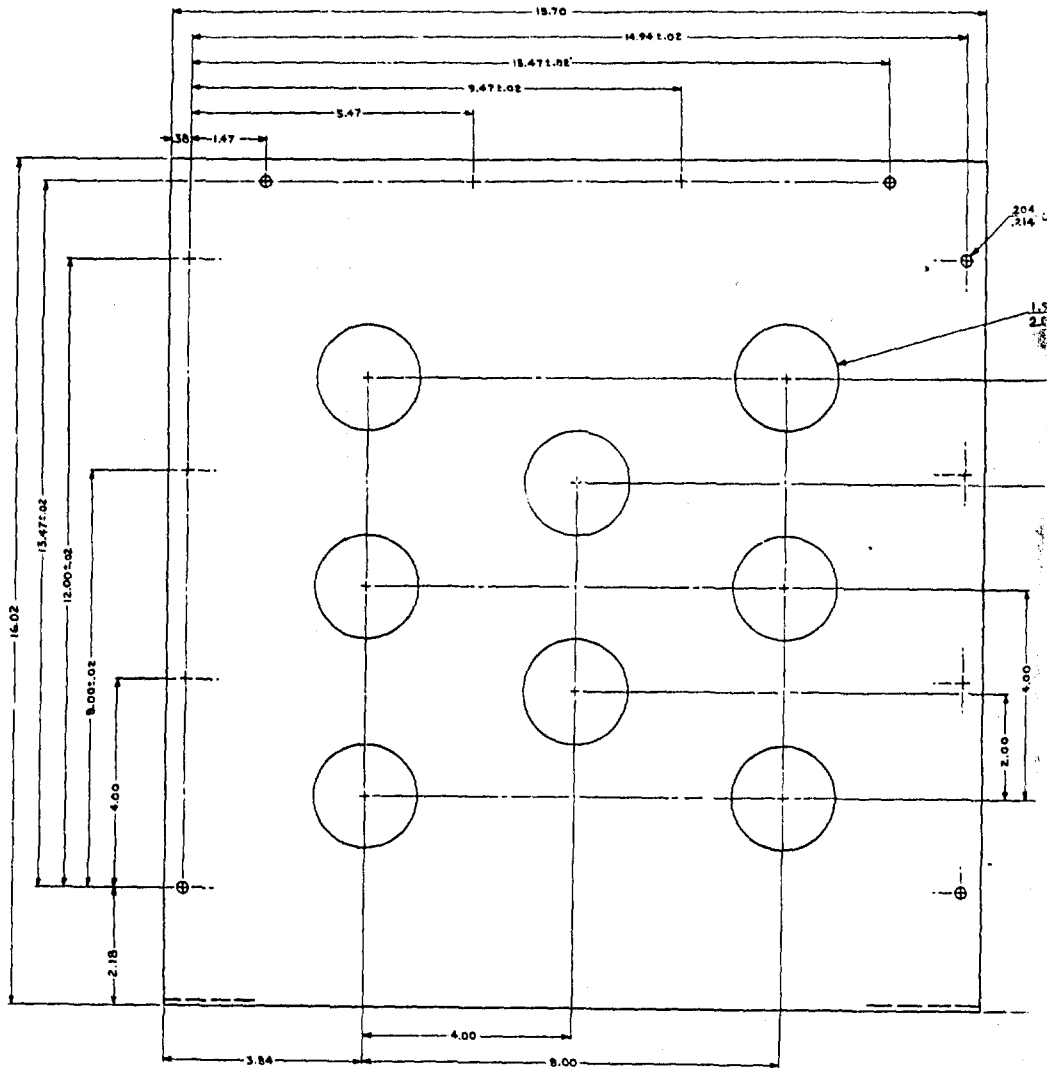

A

F

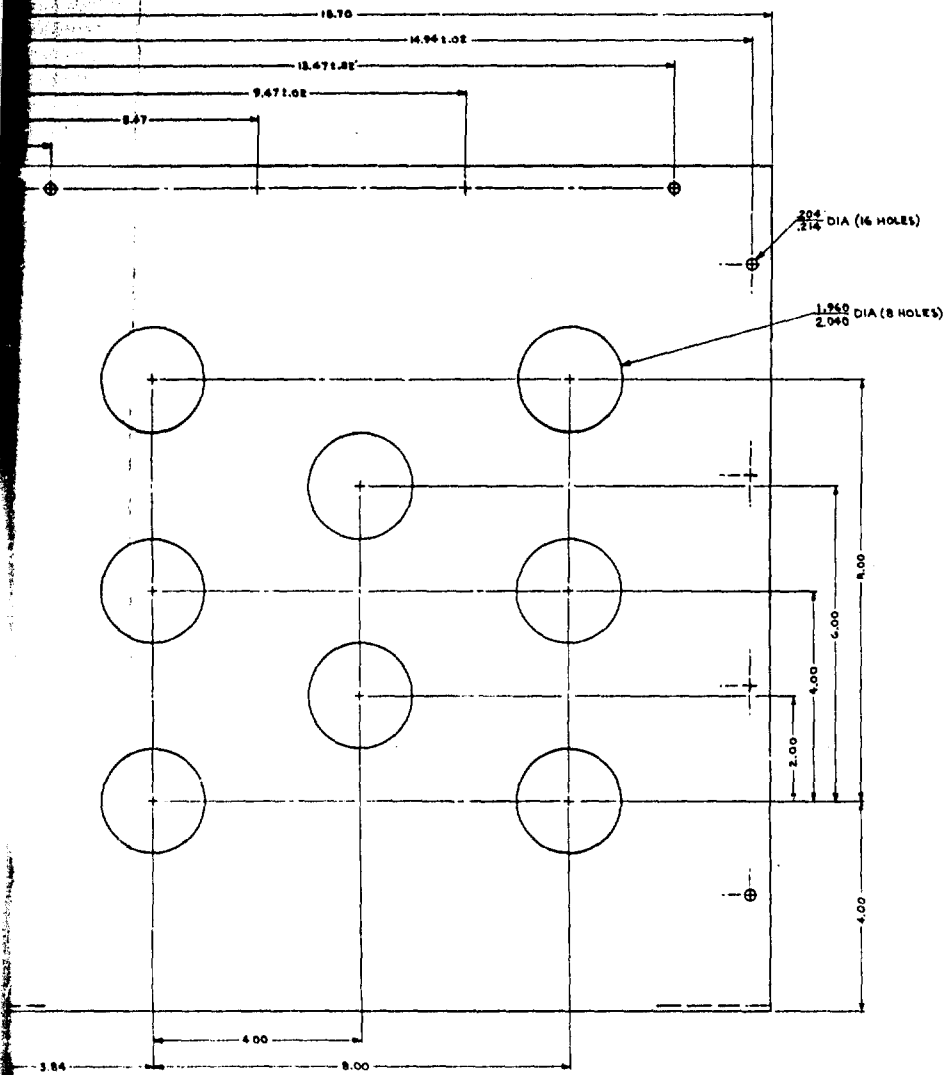

NOTE:
BEND RADIUS TO BE .05

LIST OF MATERIAL
ALUMINUM ALLOY SHEET,
.000 THK, TYPE 3052-H32

FINISH:
ALKALINE DIP (ROUGH ETCHED FROSTY-WHITE
FINISH) THEN APPLY PROTECTIVE COATING
(IRILAC 1000 ALLIED RESEARCH PROD, INC.)

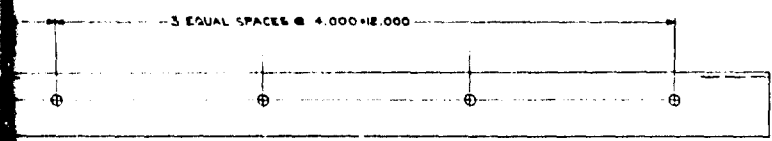
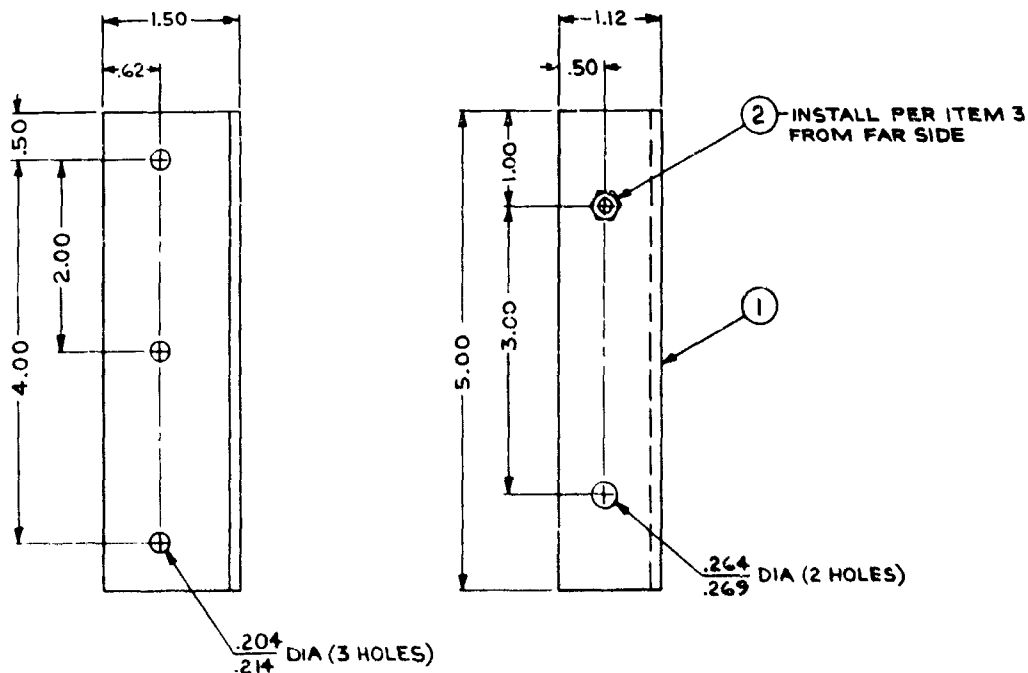

Figure A-25. Cover, Inner (E2205195)

B



NOTE:
BEND RADIUS TO BE .12

| LIST OF MATERIAL | |
|------------------|---|
| | INSTALLATION INSTRUCTIONS P6016 |
| 175120A646 | INSERT, THREADED (FLUSH TYPE) |
| | ALUMINUM, ALLOY, SHEET, .125 THK, TYPE 5052-H32 |

FINISH:
ALKALINE DIP (ROUGH ETCHED FROSTY-WHITE FINISH) THEN APPLY PROTECTIVE COATING (IRILAC 1000 ALLIED RESEARCH PROP, INC.)

Figure A-26. Angle (C2205196)

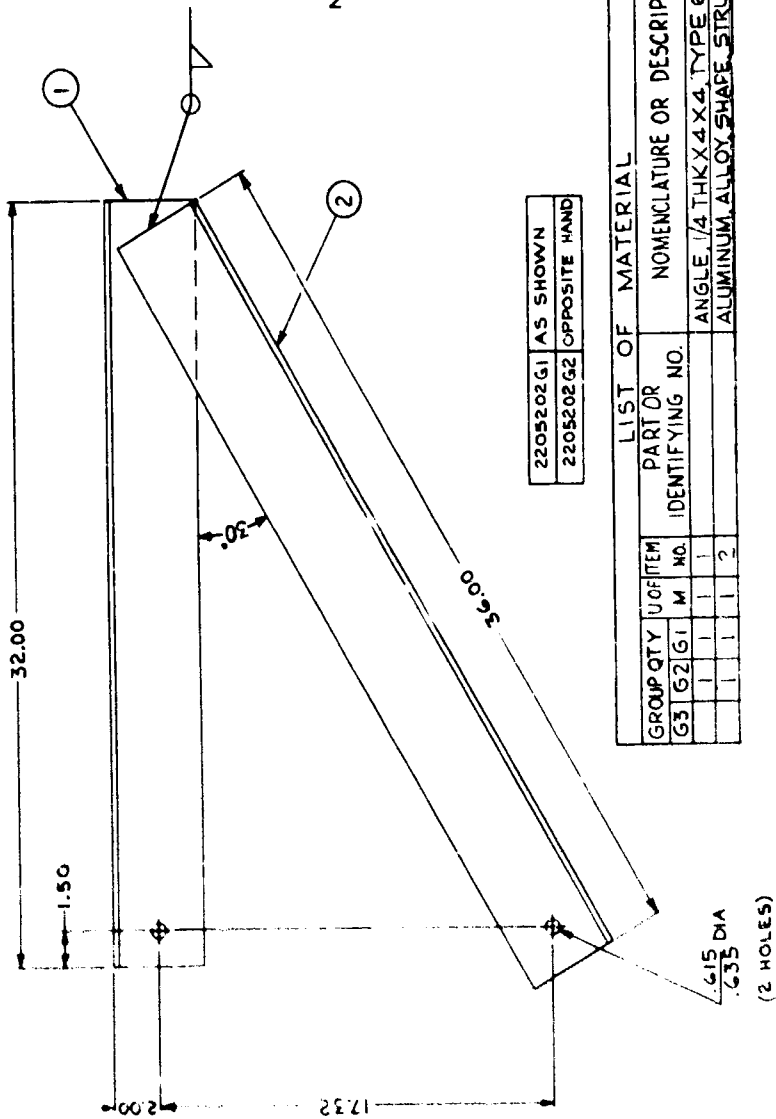
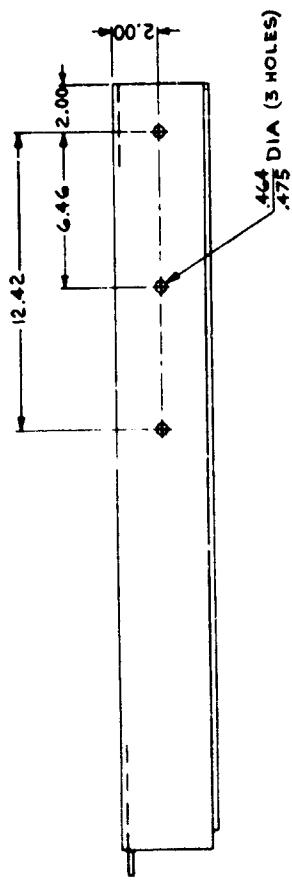

| | |
|-----------|---------------|
| 2205202G1 | AS SHOWN |
| 2205202G2 | OPPOSITE HAND |

| LIST OF MATERIAL | | PART OR IDENTIFYING NO. | | NOMENCLATURE OR DESCRIPTION | |
|------------------|-----|-------------------------|------|-----------------------------|-------------------------------------|
| GROUP | QTY | U OF | ITEM | | |
| G3 | G2 | G1 | M | NO. | |
| 1 | 1 | 1 | 1 | 1 | ANGLE 1/4 THK X 4 X 4, TYPE 6061-T6 |
| 1 | 1 | 1 | 2 | 1 | ALUMINUM ALLOY SHAPE STRUCTURAL |

Figure A-27. Support, Angle (C2205202)

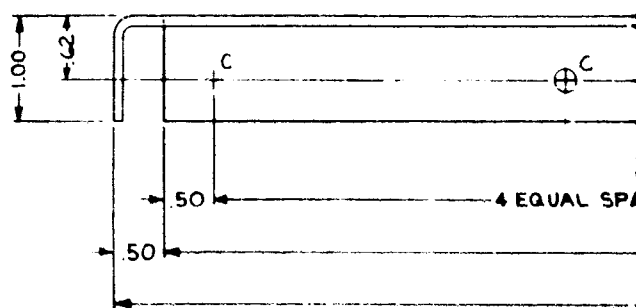
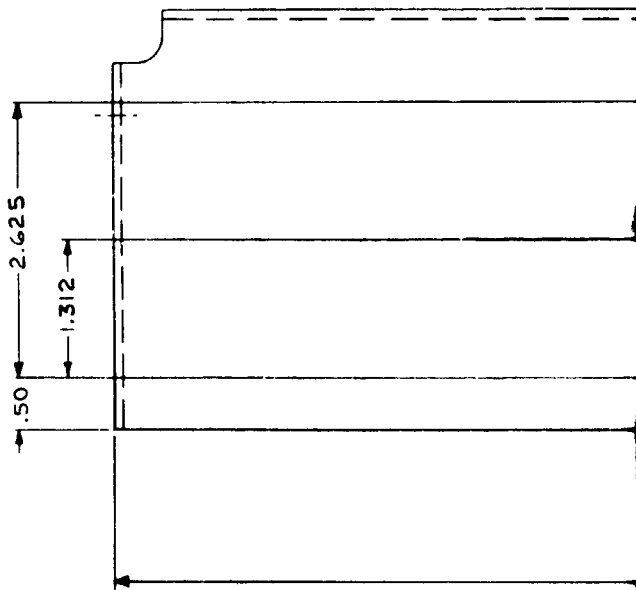
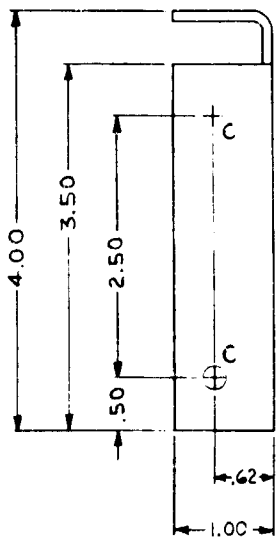

LIST OF MATERIAL
 ALUMINUM ALLOY SHEET,
 .0907-4, TYPE 5052-H32

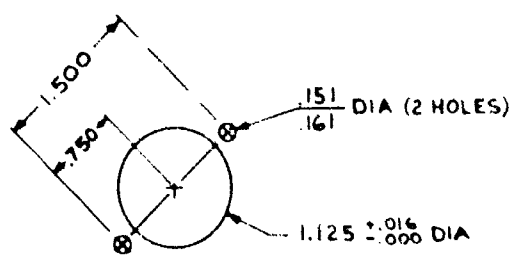

| HOLE SCHEDULE | |
|---------------|---------------|
| HOLE | DESCRIPTION |
| A | CC-1122 |
| B | .168-.178 DIA |
| C | .204-.214 DIA |

CC-1122
 A

P

.26 R (2 CORNERS)

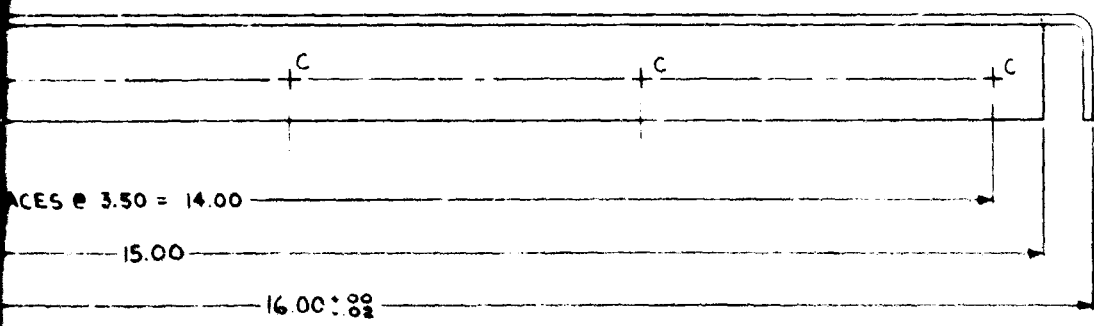
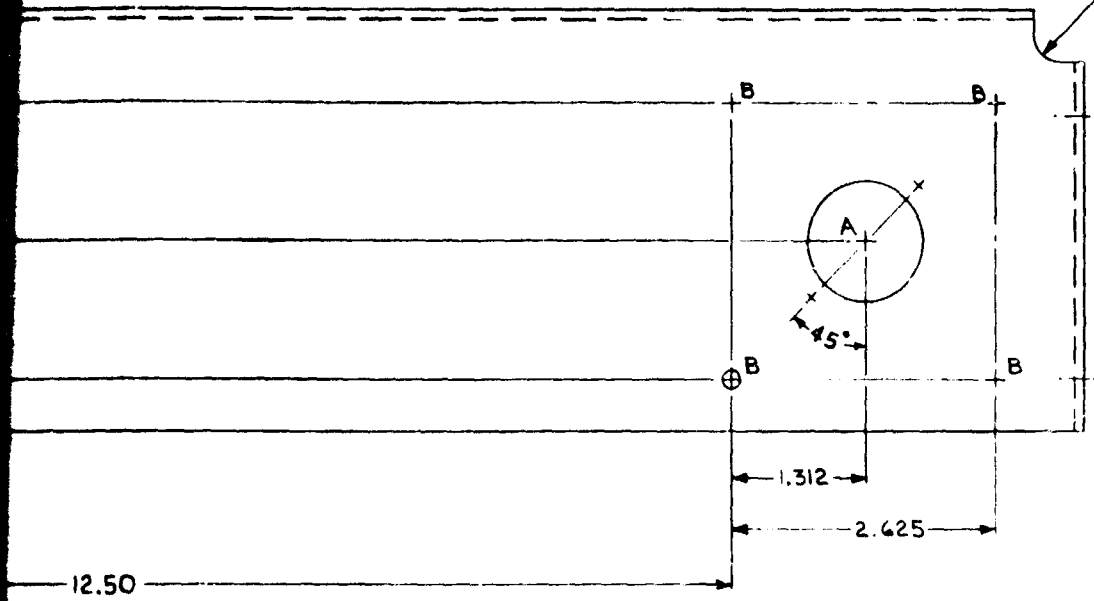

FINISH:
ALKALINE DIP (ROUGH ETCHED FROSTY-WHITE
FINISH) THEN APPLY PROTECTIVE COATING
(IRILAC #1000 ALLIED RESEARCH PROP, INC)

NOTE:
ALL BEND RADII TO BE .09

Figure A-28, Shelf (Power Supply)
(D2205197)

A-29

B

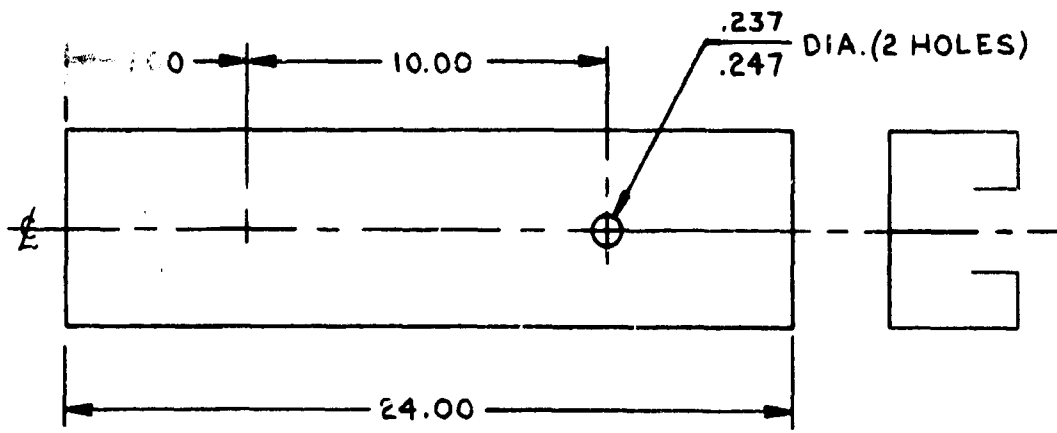

| LIST OF MATERIALS |
|---|
| UNISTRUT #P-4000 ALUMINUM - UNFINISHED |

Figure A-29. Channel (A2205198)

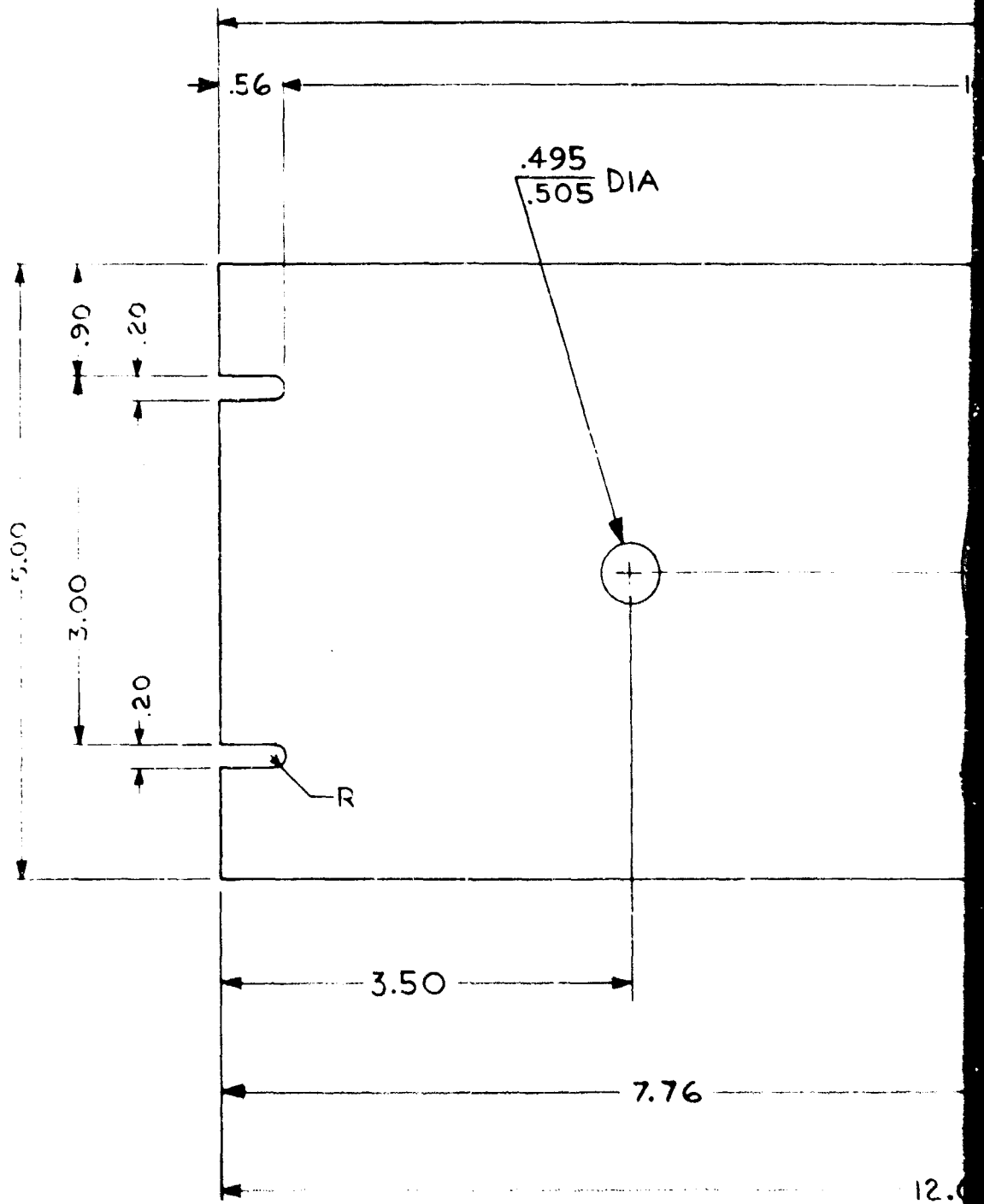

A

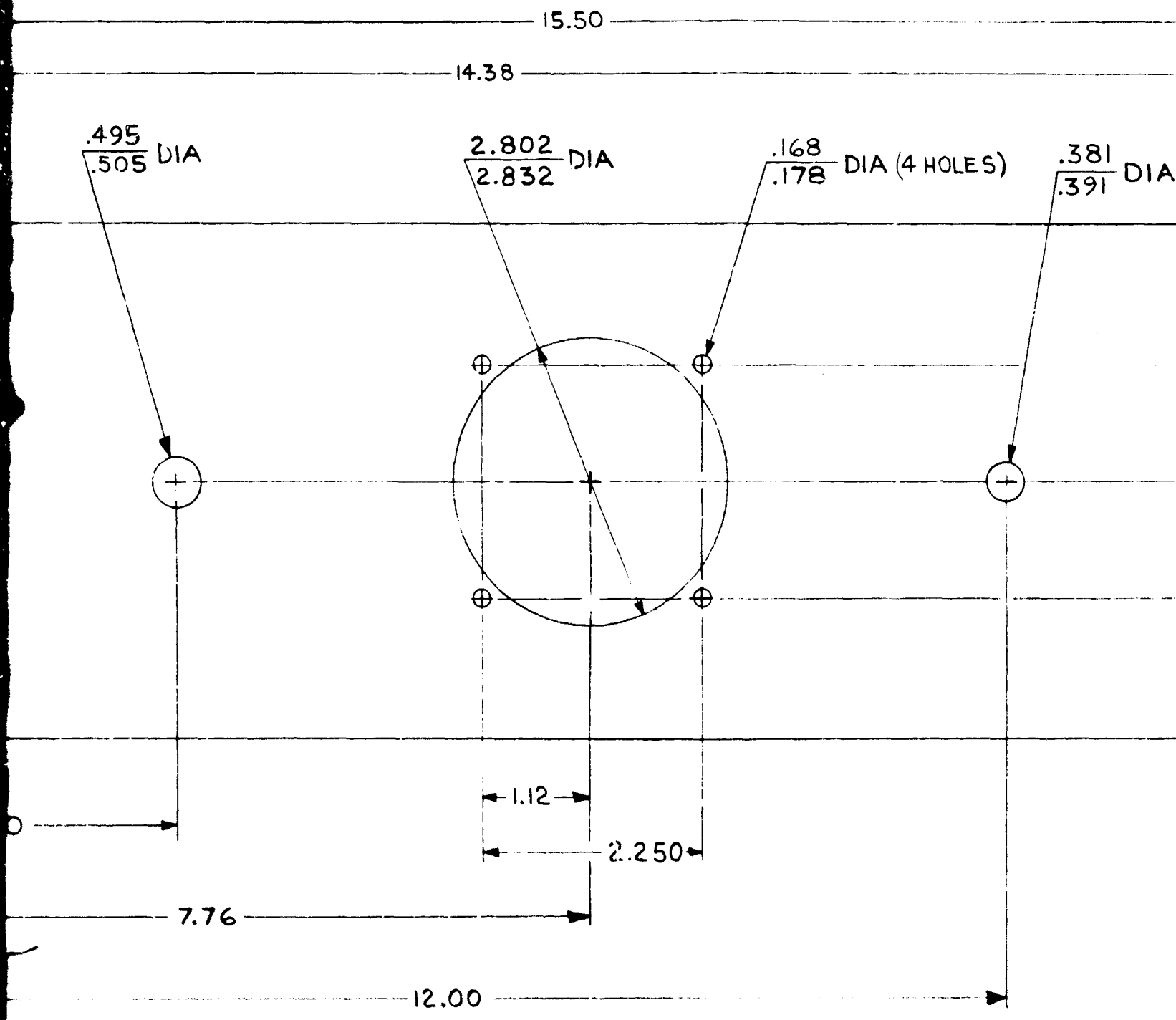

B

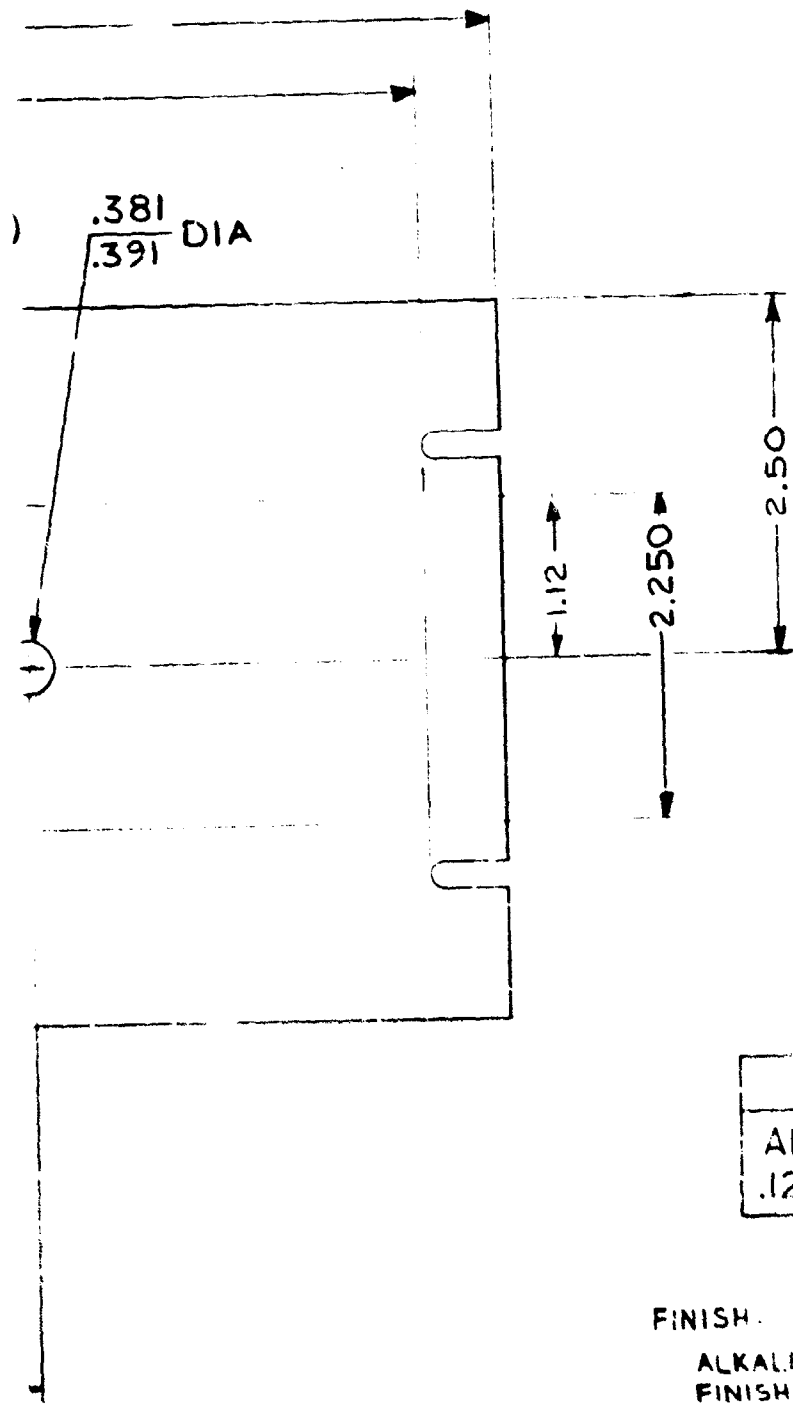

| |
|--|
| LIST OF MATERIAL |
| ALUMINUM ALLOY SHEET, .125 THK, TYPE 5052-H34 |

FINISH:
 ALKALINE DIP (ROUGH ETCHED FROSTY-WHITE
 FINISH) THEN APPLY PROTECTIVE COATING
 (IRILAC #1000 ALLIED RESEARCH PROP, INC)

Figure A-30. Panel, Meter (Drilling)
 (D2205199)

c

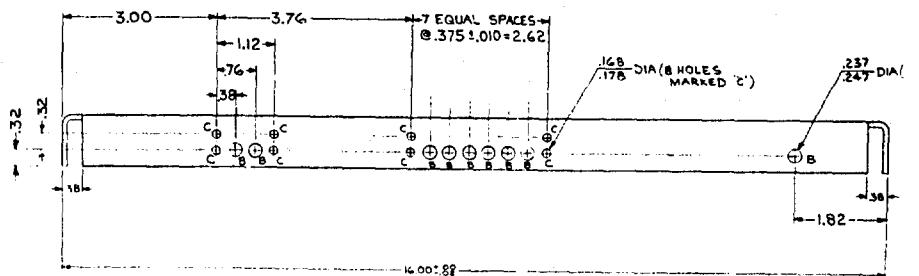
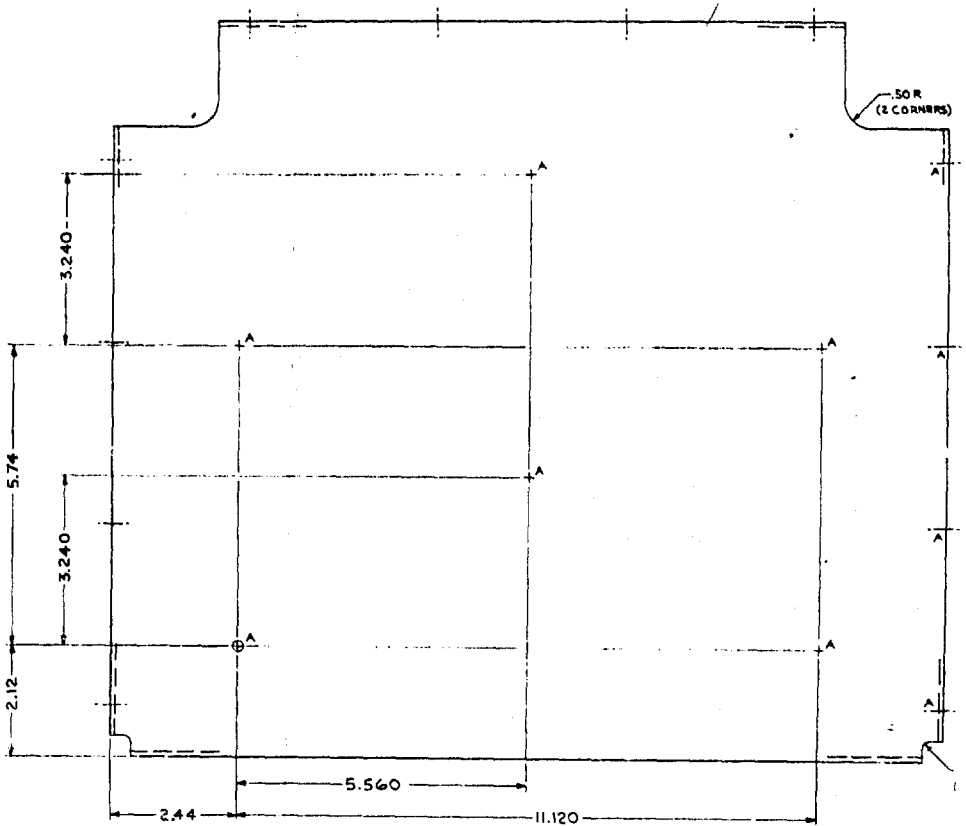
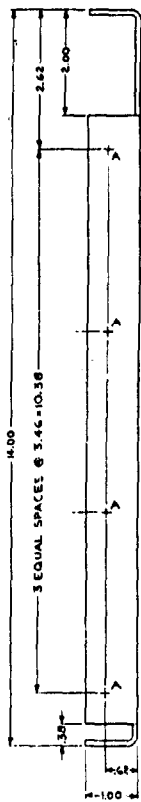
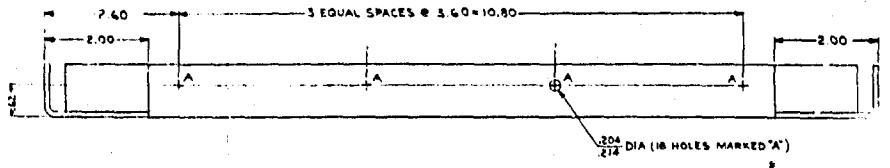

A

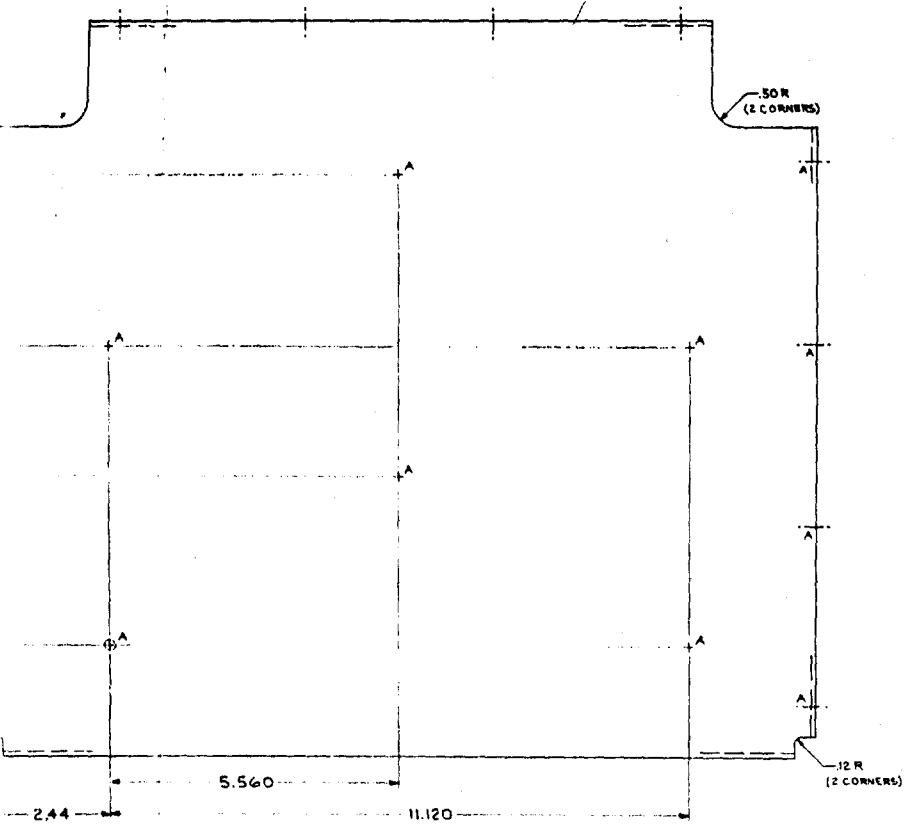
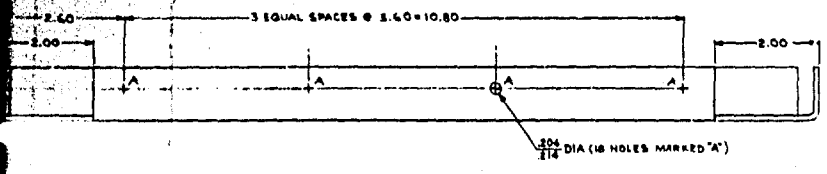

NOTE:
ALL BEND RADII TO BE .09

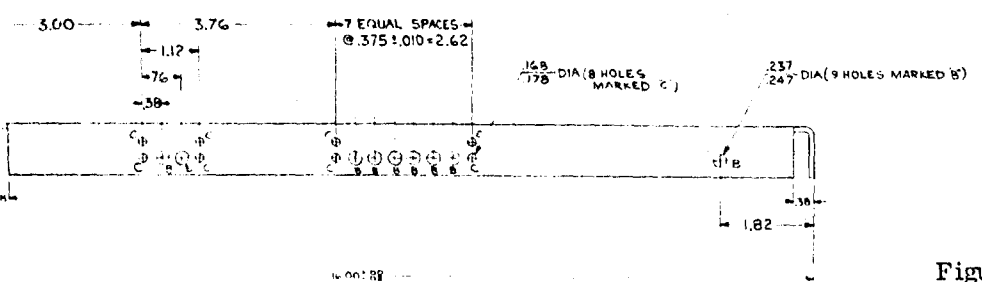

| LIST OF MATERIAL | |
|----------------------|-----------|
| ALUMINUM ALLOY SHEET | .050 THK. |
| TYPE 5052-H32 | |

FINISH
ALKALINE DIP (ROUGH ETCHED PROSTY-WHITE FINISH) THEN APPLY PROTECTIVE COATING (MILAC 1000 ALLIED RESEARCH PROP. INC)

Figure A-31. Shelf (E2205200)

A-32

B

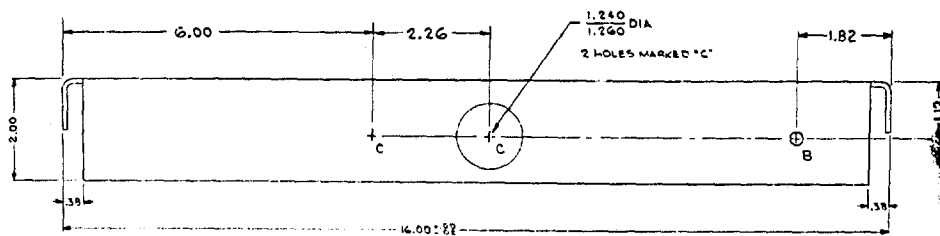
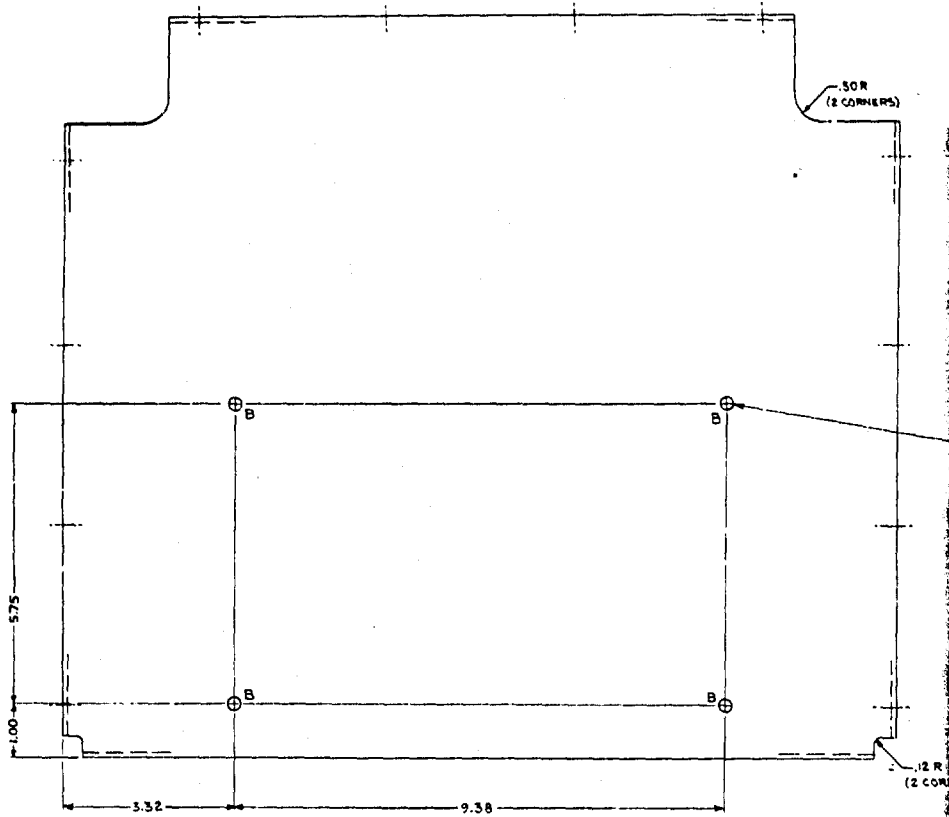
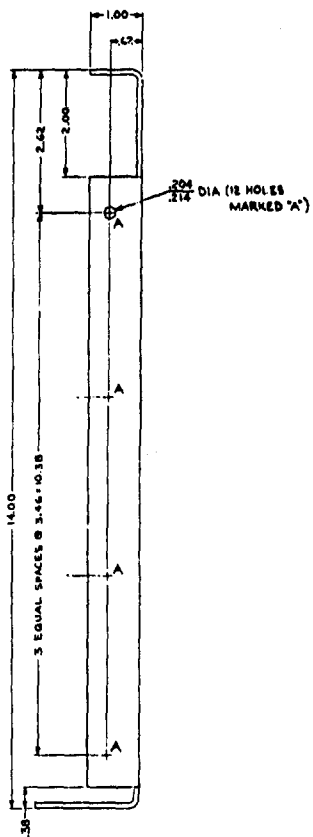
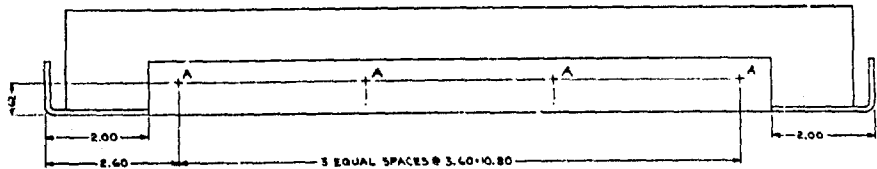

A

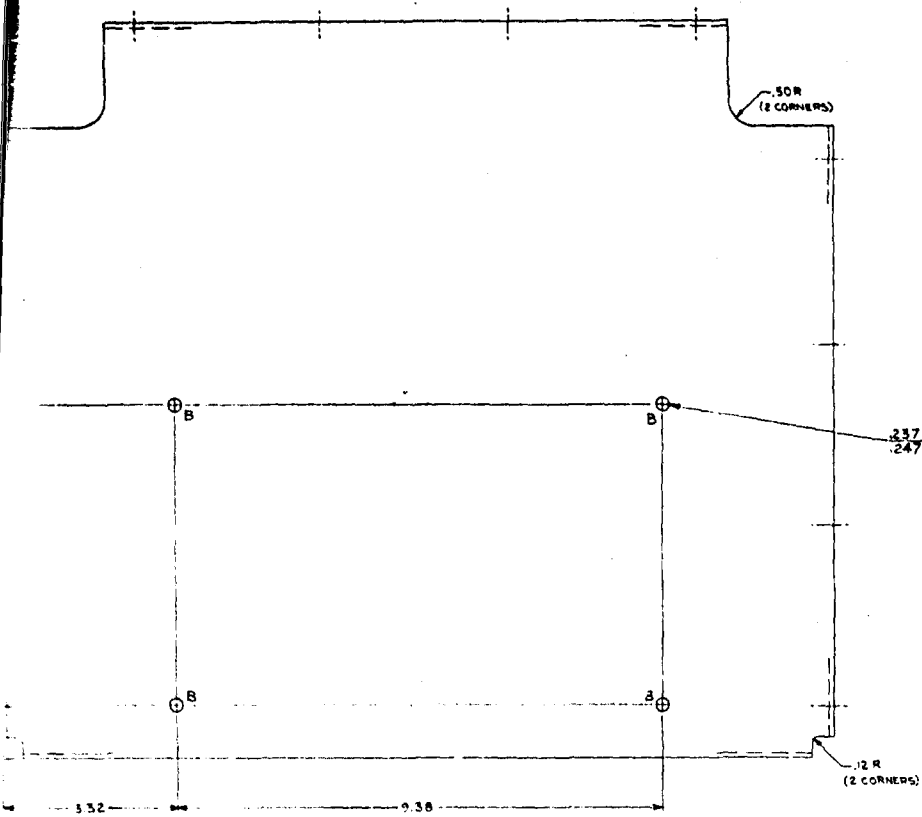
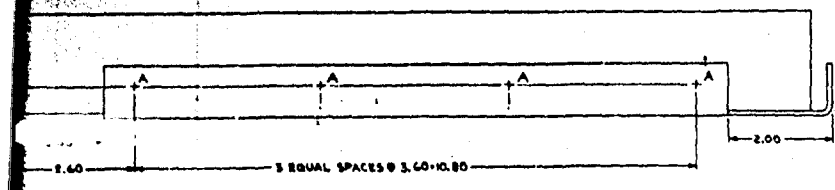

$\frac{.237}{.247}$ DIA (5 HOLES MARKED 'B')

NOTE:
ALL BEND RADII TO BE .09

LIST OF MATERIAL
ALUMINUM, ALLOY SHEET, .090 THK,
TYPE 5052-H32

FINISH:
ALKALINE DIP (ROUGH ETCHED FROSTY-WHITE
FINISH) THEN APPLY PROTECTIVE COATING
(IRILAC 1000 ALLIED RESEARCH PROD, NC)

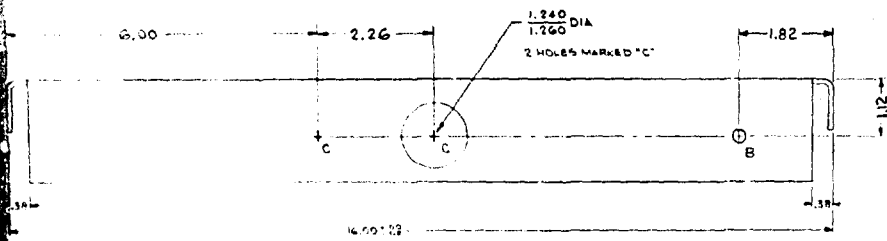
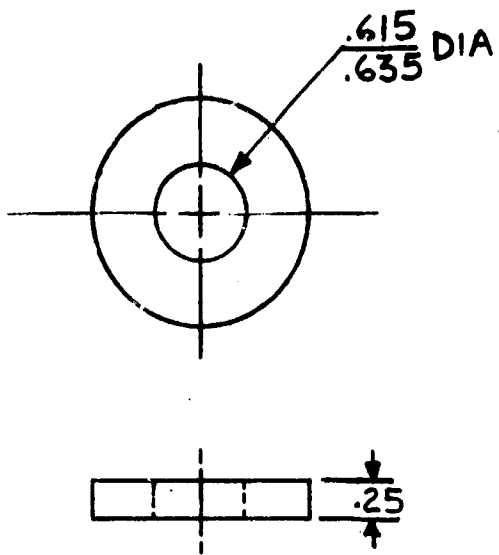

Figure A-32. Shelf (E2205201)

A-33

B



MATERIAL:

ALUMINUM, ALLOY, ROD, $1/2$ DIA, TYPE 6061-T6

FINISH:

NONE

Figure A-33. Spacer (A2205204)

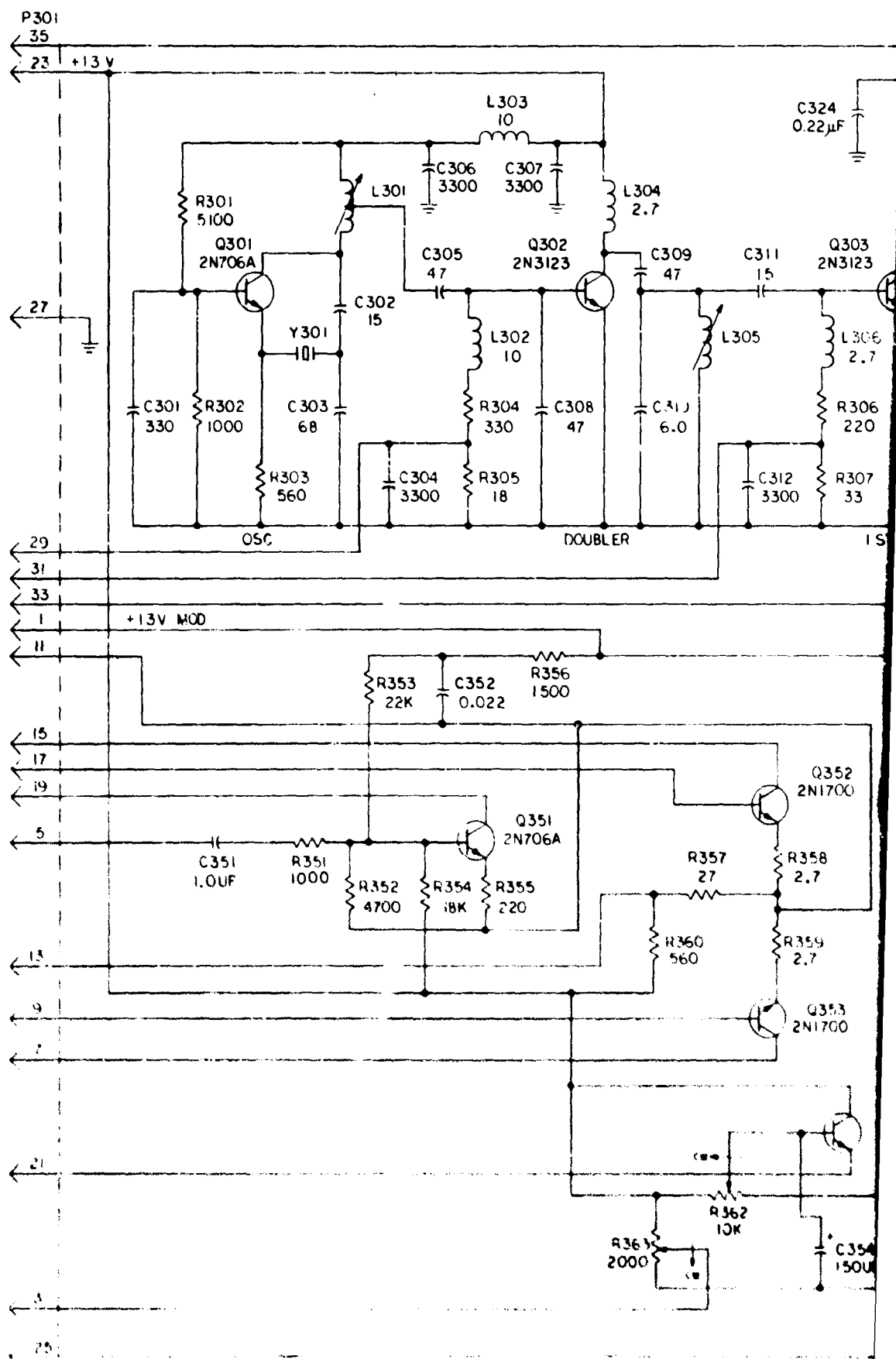

A

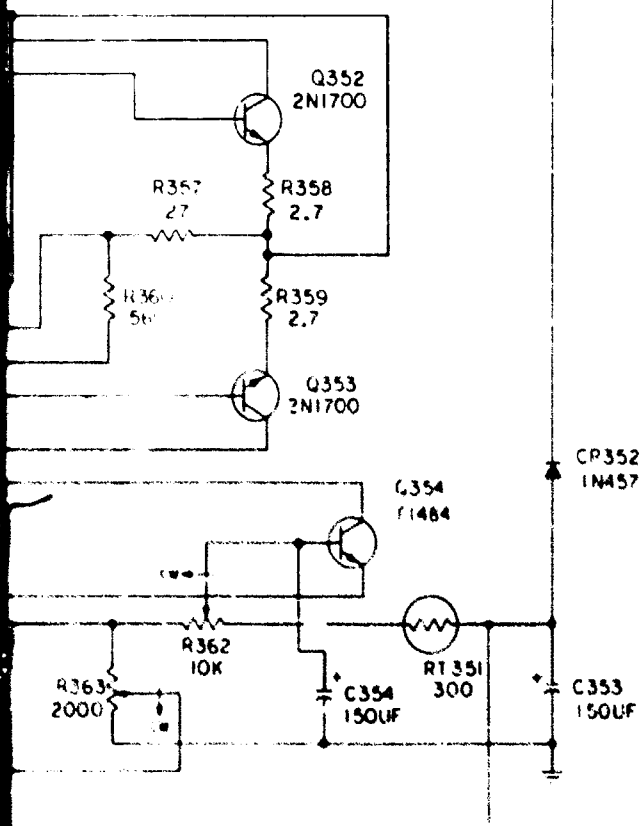
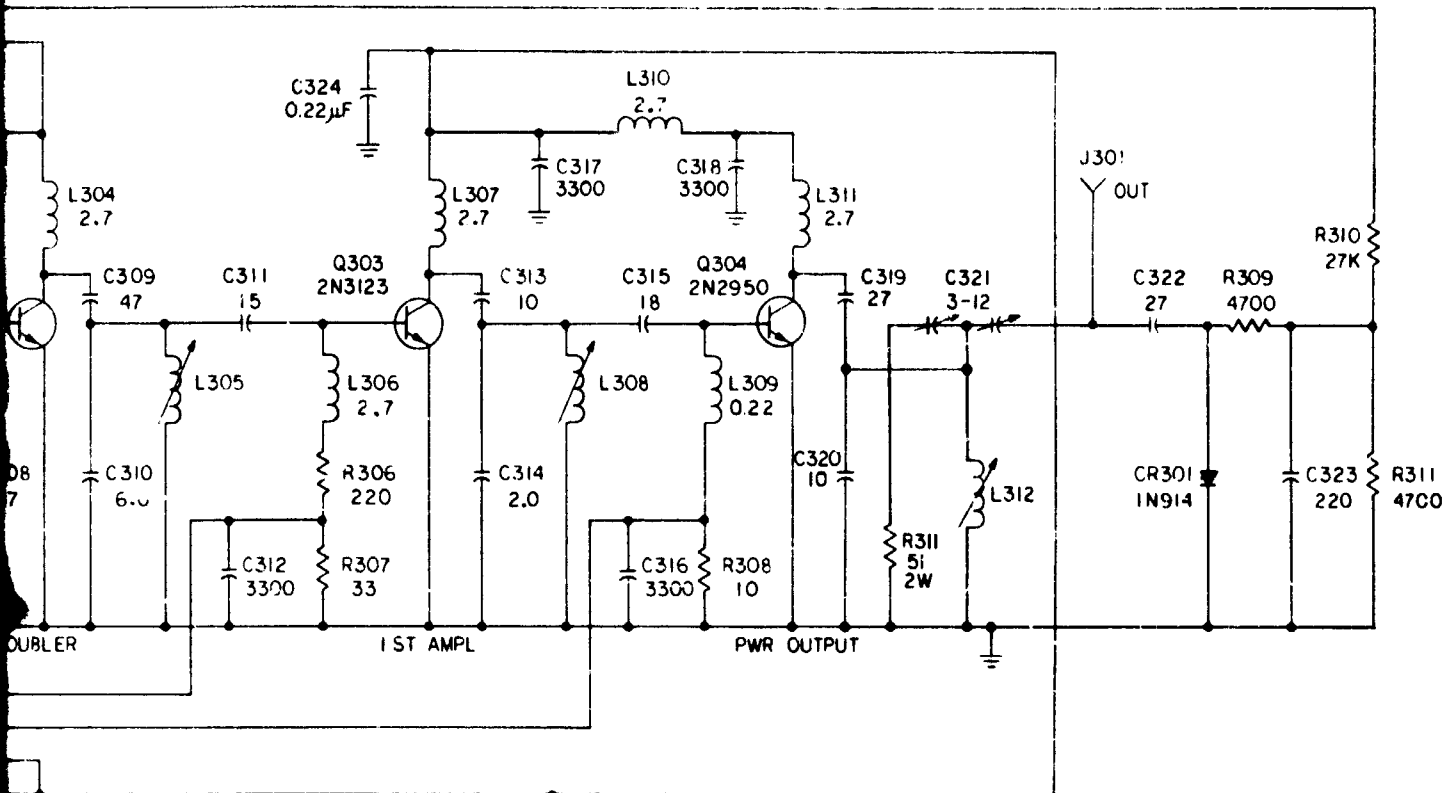

NOTES:
 1. UNLESS OTHERWISE SPECIFIED:
 RESISTANCE VALUES ARE IN OHMS.
 CAPACITANCE VALUES ARE IN PICOFARADS.
 INDUCTANCE VALUES ARE IN MICROHENRIES.

Figure A-34. Schematic Diagram, RF-Modulator Marker Beacon (E2205205)

B

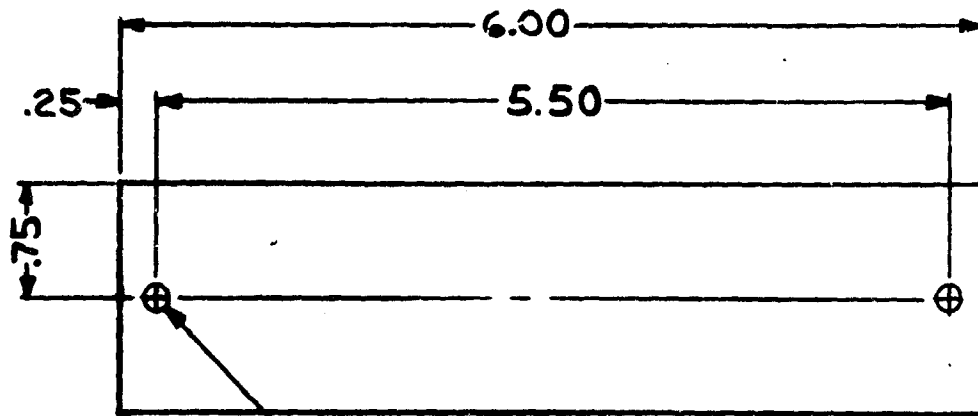

$\frac{.237}{.247}$ DIA (2 HOLES)

| |
|-----------------------|
| LIST OF MATERIAL |
| ALUMINUM, ALLOY, |
| ROD, RECT, 1/4 X 1/2, |
| TYPE 2024-T4 |

Figure A-35. Plate (B2205208)

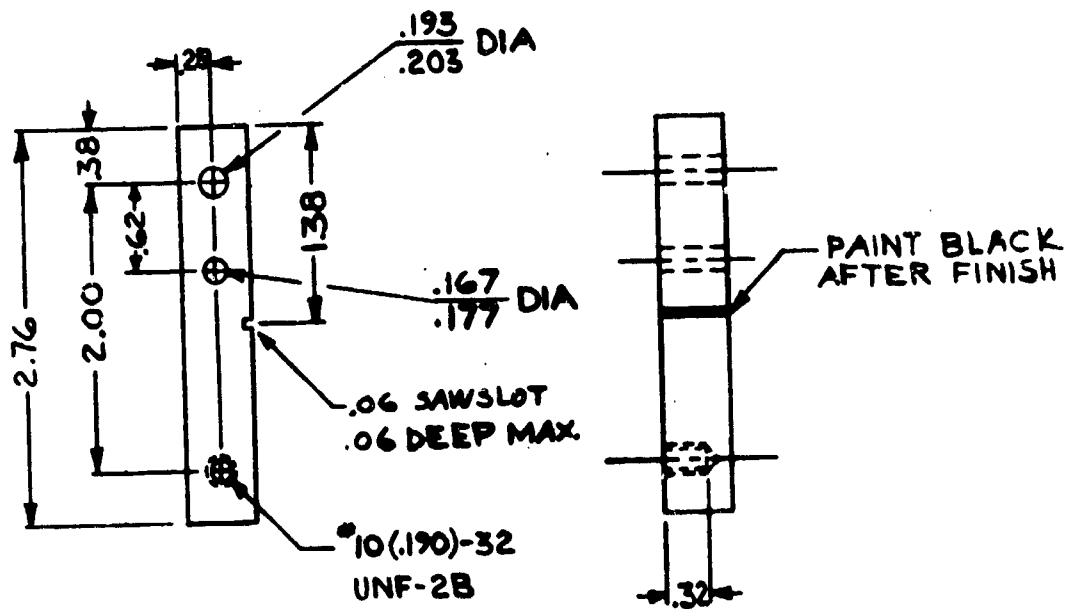

| LIST OF MATERIAL |
|---|
| BRASS, BAR, SQ, 1/2 X 1/2, HALF HARD, BEST COML QUALITY |

Figure A-36. Handle (B2205209)

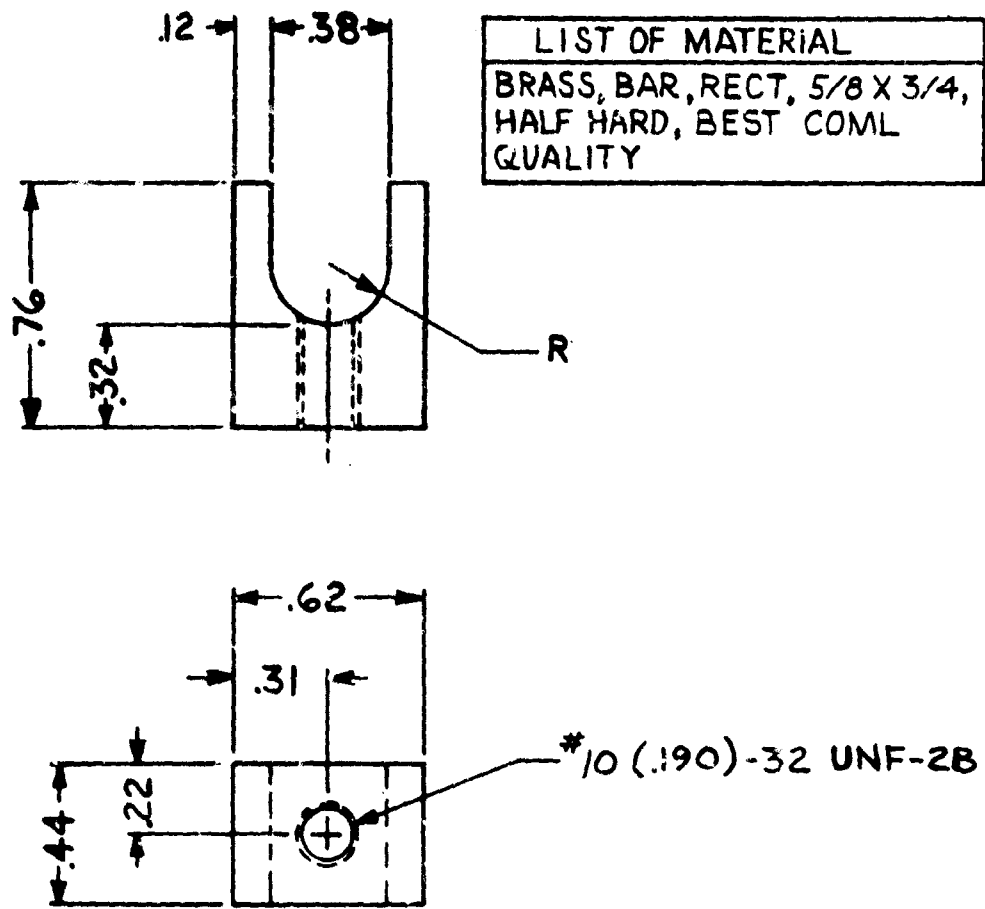
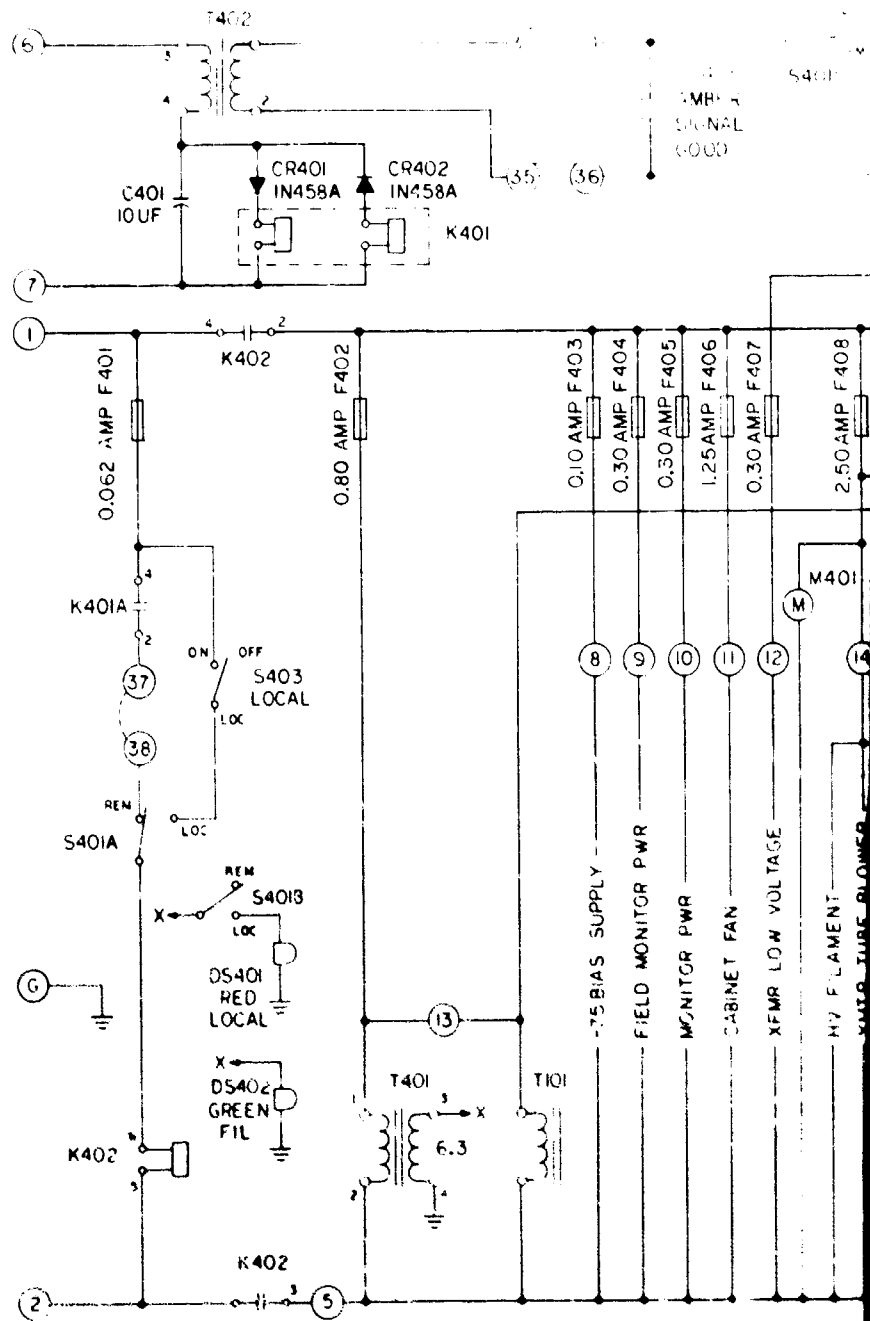
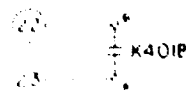

Figure A-37. Clamp (B2205210)



NOTES:

1. UNLESS OTHERWISE SPECIFIED, RESISTANCE VALUES ARE IN OHMS.
2. SERIES 100 TRANSMITTER
3. MODULATOR
4. MONITOR
5. CONTROL PANEL
6. 1/2 WATT FLUORESCENT TUBE INSTALLATIONS, WITH DIMMER FOR LOCAL INSTALLATIONS



S401
REA

A

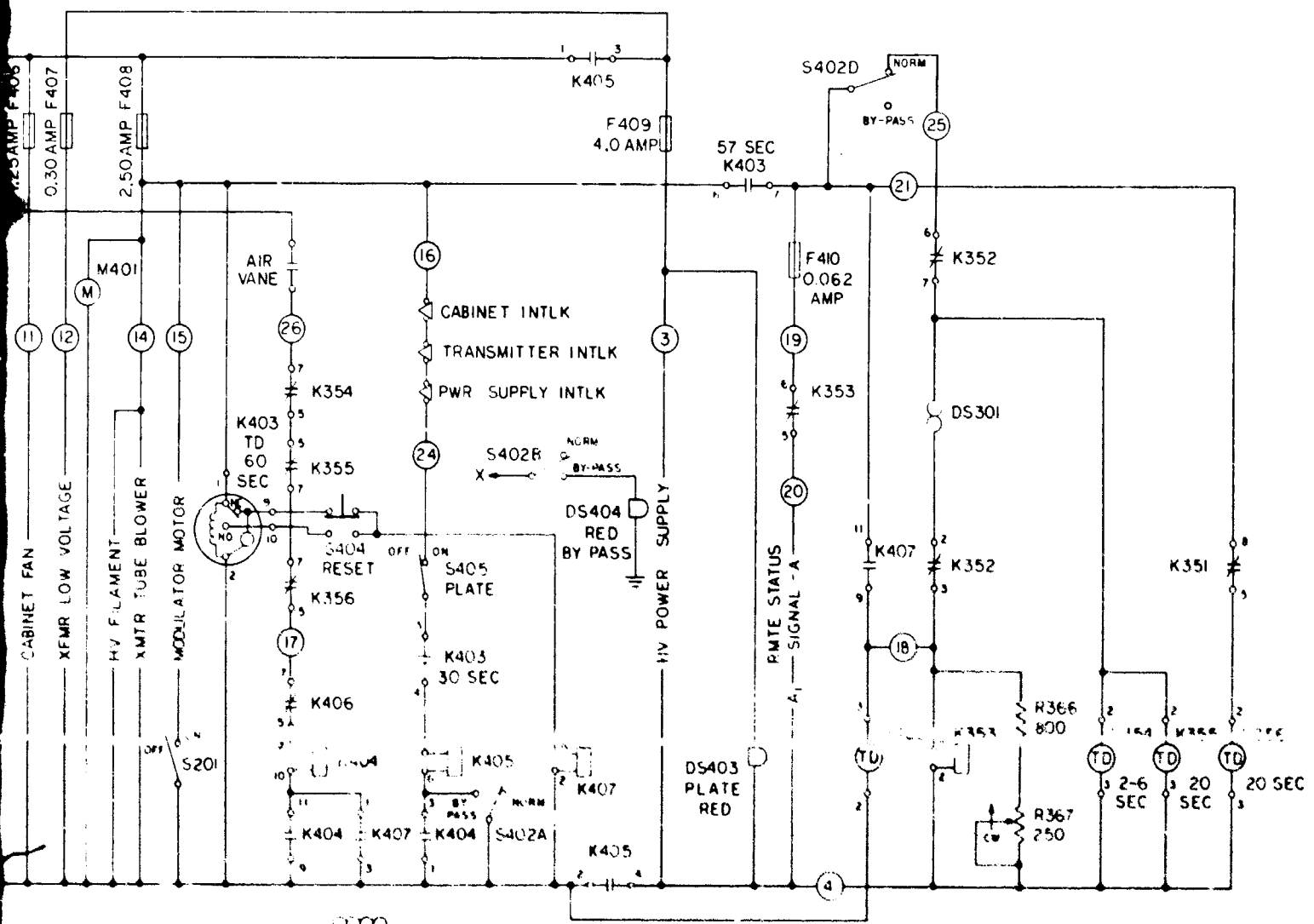
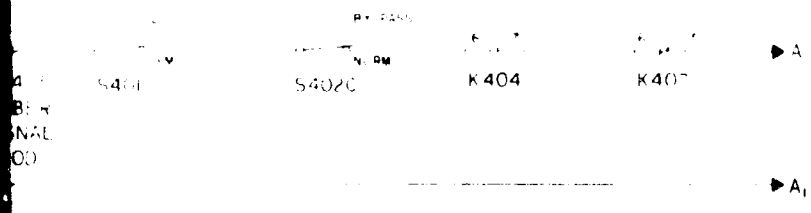
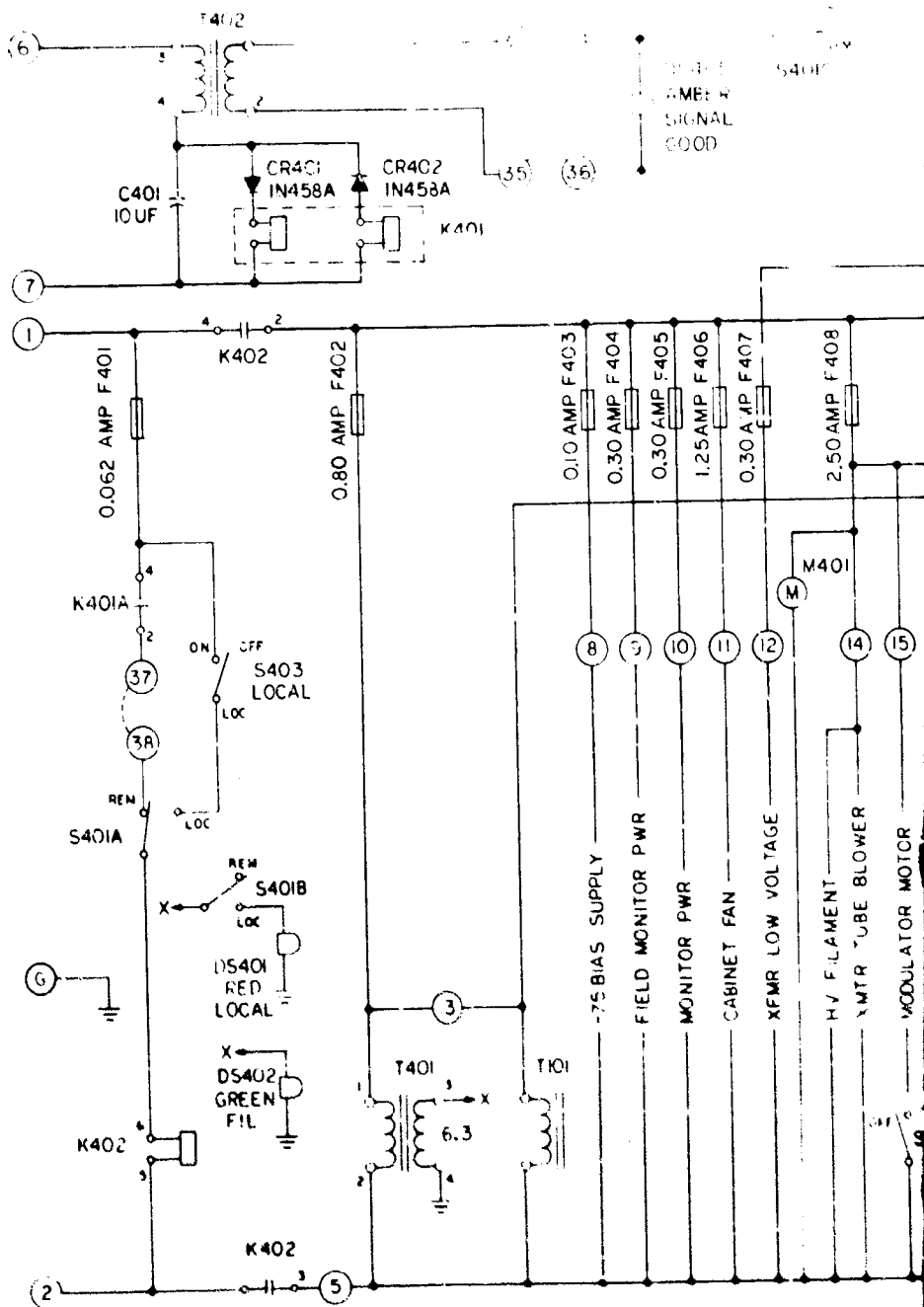

Figure A-38. Schematic Diagram, Main Control Unit (Single) Modifications to Dualized Equip. GS Transmitter No. 1 (E2205211)



NOTES:

1 UNLESS OTHERWISE SPECIFIED RESISTANCE VALUES ARE IN OHMS.

2 SERIES RESISTOR TRANSMITTER
 3 MODULATOR
 4 MONITOR
 5 CONTROL PANEL

3 IN STATES POWER ON SINGLE INSTALLATIONS
 4 IN STATES POWER OFF IN INSTALLATIONS

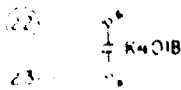

S401 S401
 REAR VIEW

A

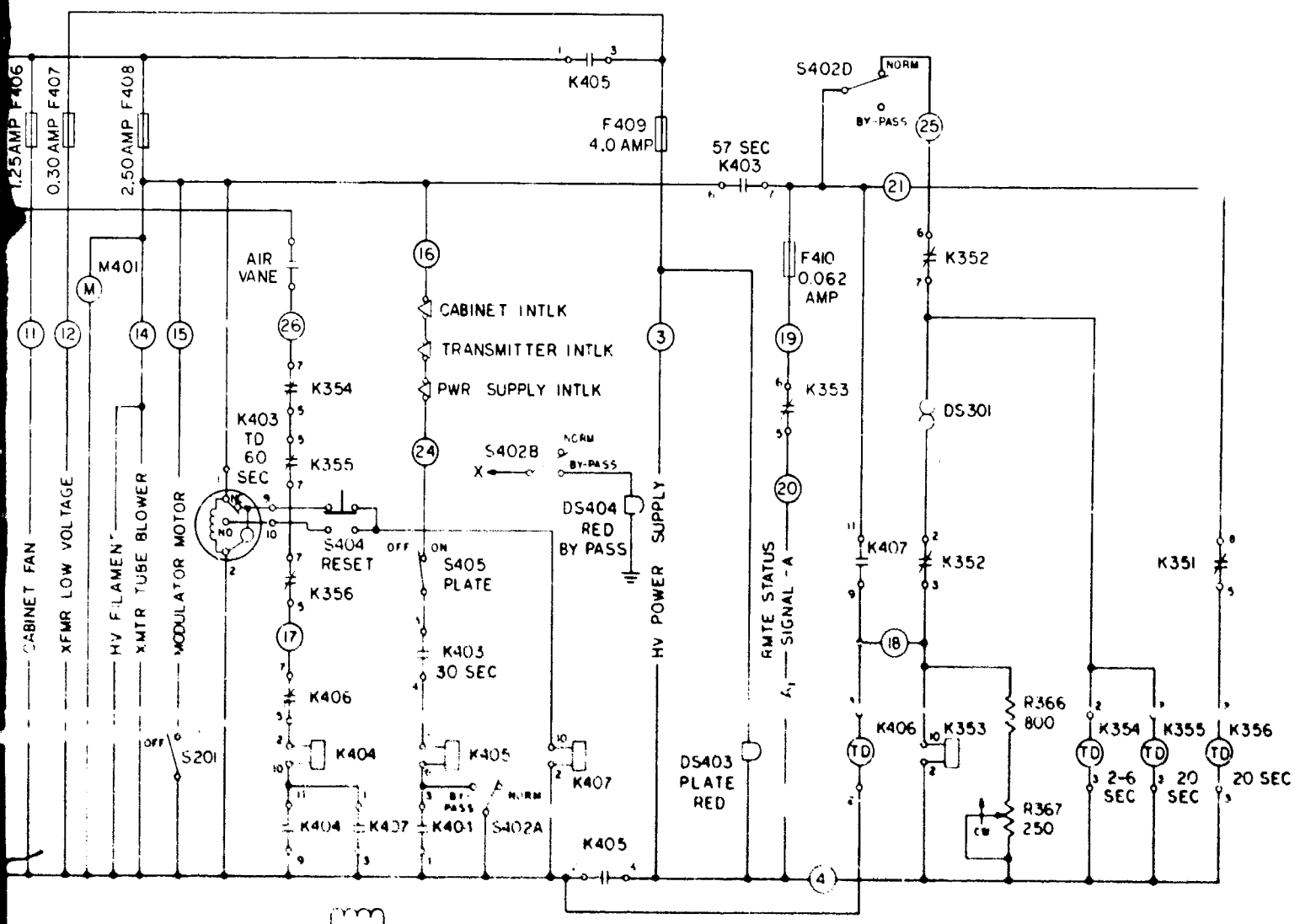
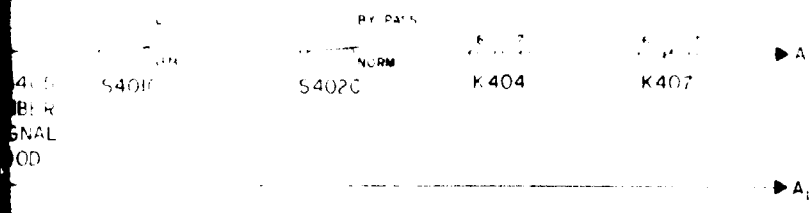

Figure A-38. Schematic Diagram, Main Control Unit (Single) Modifications to Dualized Equip. GS Transmitter No. 1 (E2205211)

B

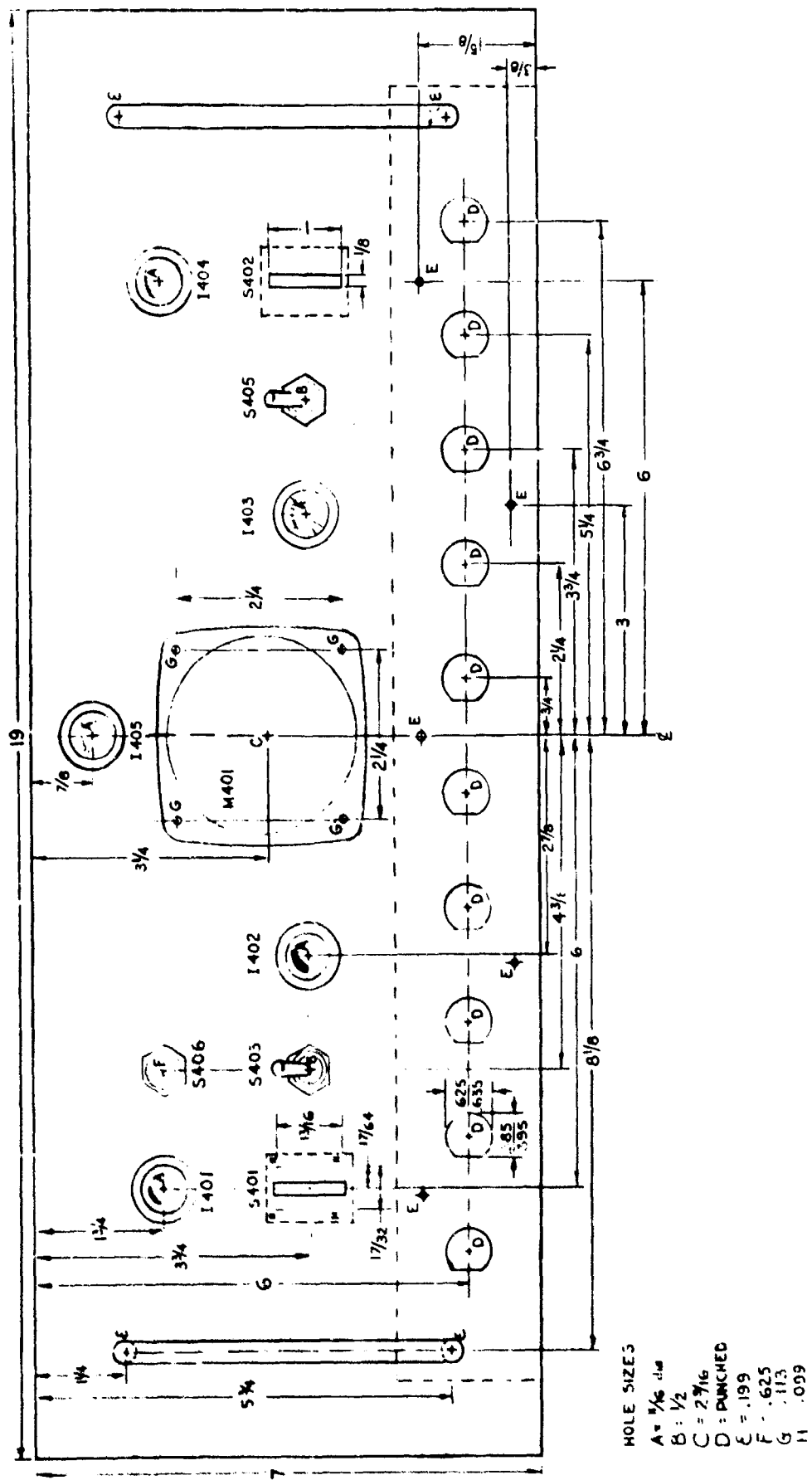
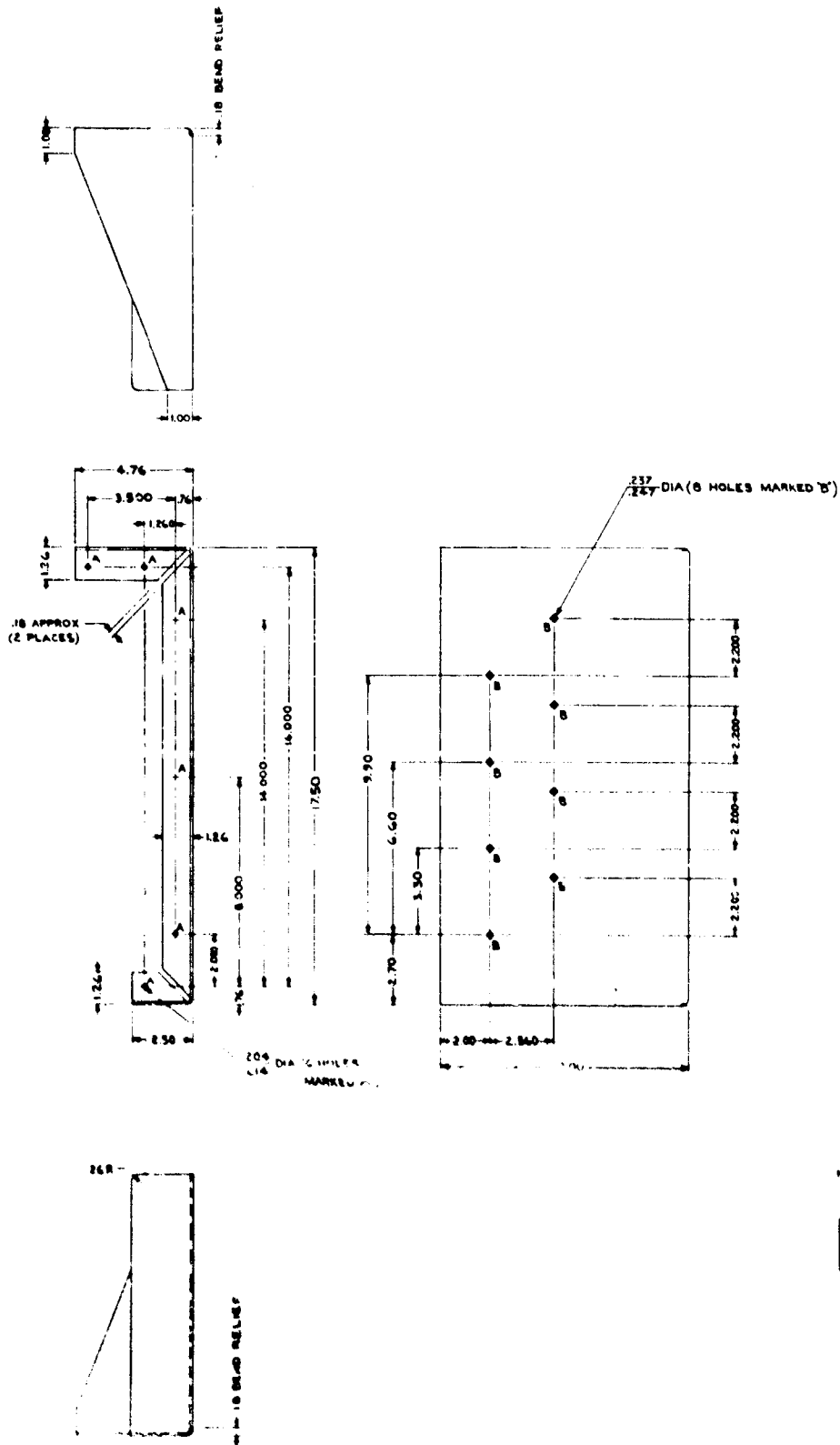

Figure A-39. Control Unit Front Panel Drilling (C2205213)



NOTE:
ALL BEND RADI TO BE .09

LIST OF MATERIAL
ALUMINUM ALLOY SHEET
390 THK TYP 5052-H32

FINISH:
ALKALINE DP (ROUGH ETCHED PROSTY-WHITE
FINISH) THEN APPLY PROTECTIVE COATING
(KILAC 1800 ALUED RESEARCH PROP. INC)

Figure A-40. Bracket (E2205215)

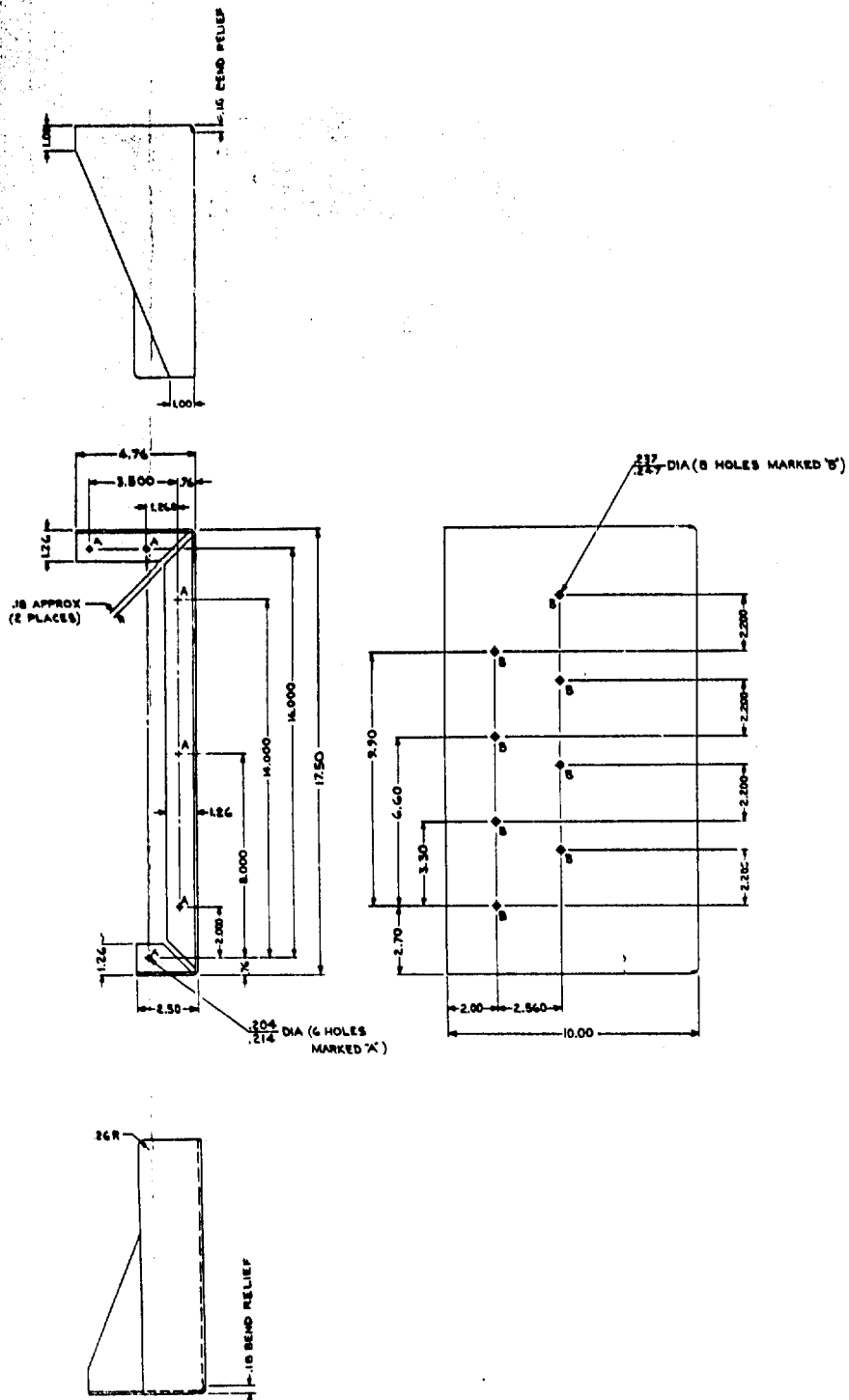
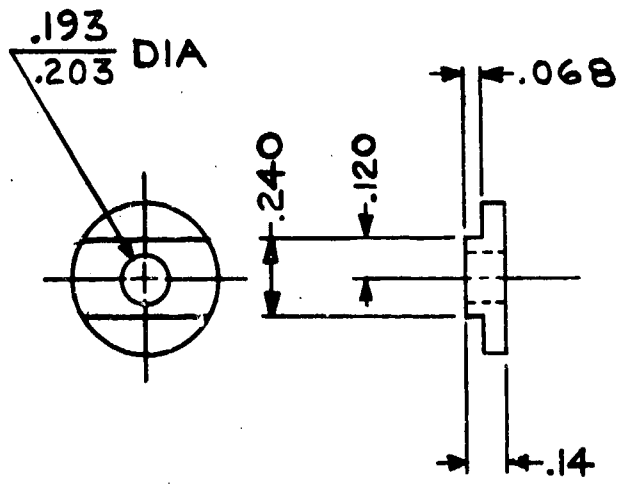
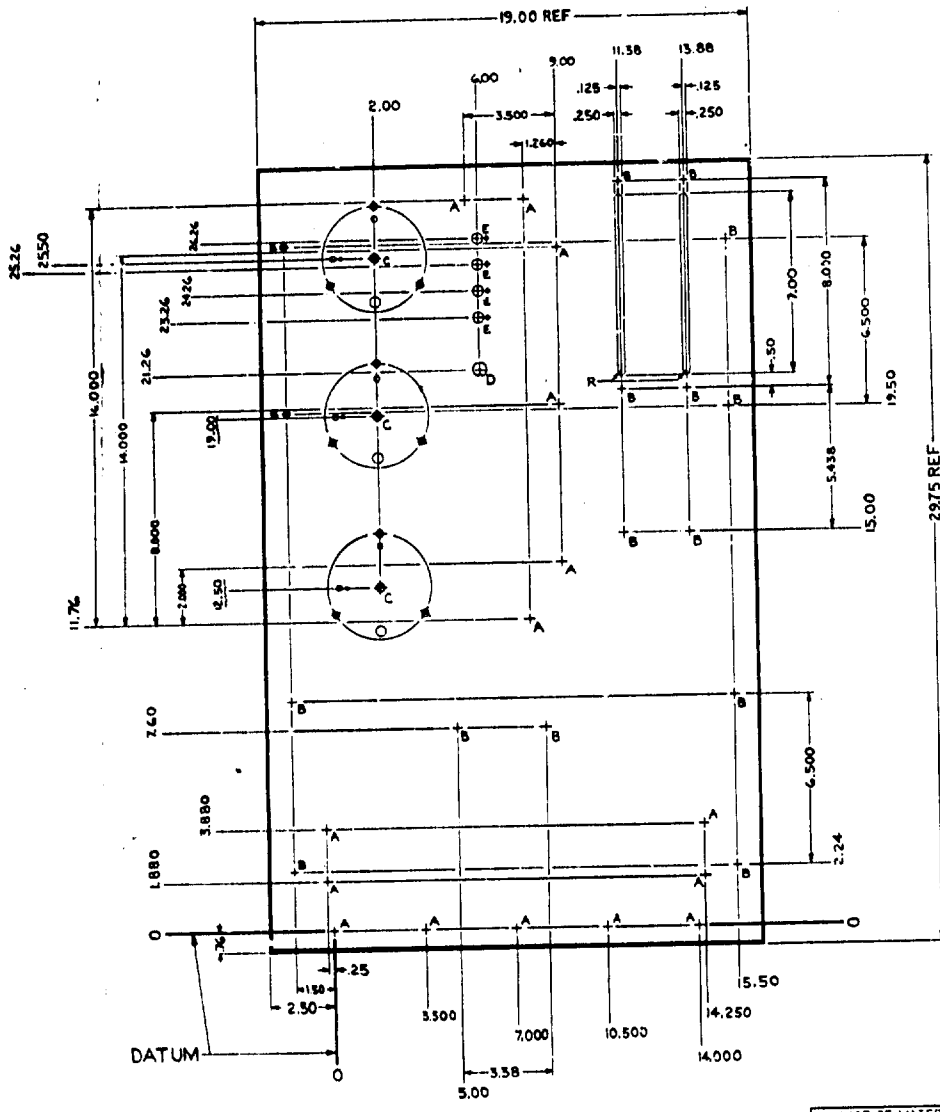

Figure A-40. Bracket (E2205215)



| |
|-----------------------|
| LIST OF MATERIAL |
| TEFLON, ROD, 1/2 DIA. |
| BEST COML QUALITY |

Figure A-41. Washer (B2205216)



| HOLE | DESCRIPTION |
|------|---------------|
| A | .204-.214 DIA |
| B | .237-.247 DIA |
| C | SEE LAYOUT |
| D | DJ-0480 |
| E | SEE LAYOUT |
| F | .167-.177 DIA |
| G | .307-.318 DIA |
| H | .381-.391 DIA |
| J | .088-.089 DIA |

LIST OF MATERIAL
ANCO ENCLOSURE PANEL
#P-29

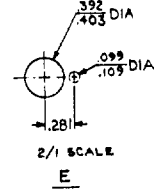
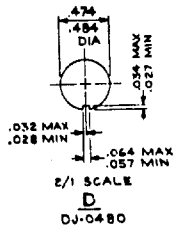
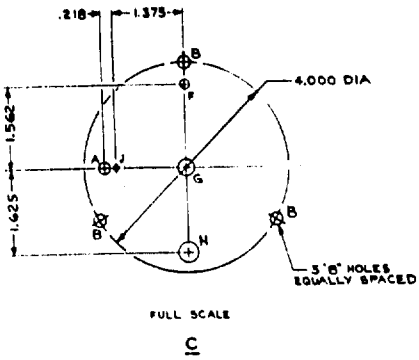
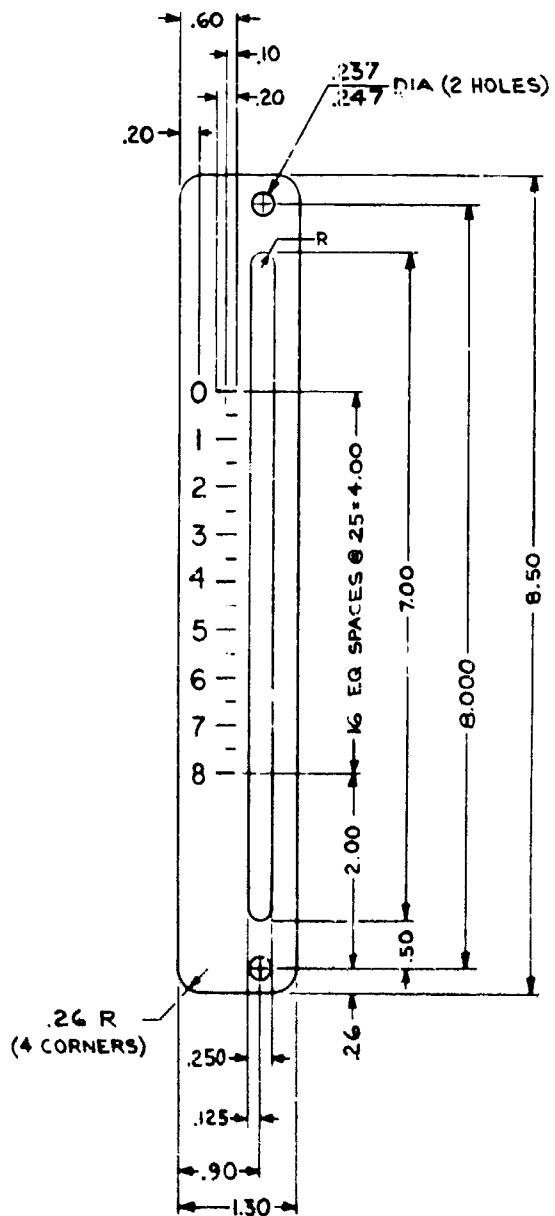

Figure A-42. Panel, Front (Drilling)
(E2205217)



NOTES:

1. MARK PER A2205220 PARA 'B',
PAINT TO BE BLACK IN COLOR.
2. CHARACTERS TO BE 18 POINT
UNLESS OTHERWISE SPECIFIED
& CENTRALLY LOCATED AS SHOWN
3. ALL LINES TO BE .03 THK.

| LIST OF MATERIAL |
|--|
| ALUMINUM ALLOY, SHEET, .063 THK, TYPE 5052-H34 |

FINISH:

ALKALINE DIP (ROUGH ETCHED FROSTY-WHITE
FINISH) THEN APPLY PROTECTIVE COATING
(IRILAC #1000 ALLIED RESEARCH PROP, INC.)

Figure A-43. Plate, Calibration (C2205219)

SPECIFICATION FOR MARKING

APPLY CHARACTER MARKINGS LOCATED AS SHOWN ON DRAWING USING "A" OR "B".

"A" - RUBBER STAMPING

1. INK TO BE OPAQUE BLACK UNLESS OTHERWISE SPECIFIED, AERO-BRAND OR EQUAL.
2. COVER CHARACTERS WITH ONE COAT OF CLEAR LACQUER. LACQUER TO BE AGATEEN LACQUER AS MANUFACTURED BY THE AGATE LACQUER MFG. CO., OR EQUAL.

"B" - SILK SCREENING

1. INK TO BE WHITE, UNLESS OTHERWISE SPECIFIED, NAZDAR CORP., CHICAGO ILL, EPOXY INK, OR EQUAL.

NOTES:

1. DO NOT PRINT DIMENSIONS OR DIMENSION LINES THAT APPEAR ON PART DRAWING.
2. IN DIMENSIONING MARKINGS, THE FOLLOWING PRECAUTIONS MUST BE TAKEN:
 - A. CHARACTERS SHOULD BE AT LEAST 1/16" FROM ALL HOLES.
 - B. CHARACTERS SHOULD BE AT LEAST 1/8" FROM EDGES.
 - C. IN DEALING WITH STEPPED SURFACES, CHARACTERS SHOULD BE AT LEAST 3/8" FROM BEGINNING OR END OF CURVE AT THE BEGINNING OF STEP.
3. CHARACTERS TO BE CENTRALIZED WITH ADJACENT HOLE UNLESS OTHERWISE SPECIFIED.
4. CHARACTERS TO BE AMERICAN TYPE FOUNDERS ALTERNATE VERTICAL GOTHIC #3 (UPPER CASE). USE CONDENSED LETTER SPACING.

UNLESS OTHERWISE SPECIFIED THE FOLLOWING CHARACTER SIZES SHALL BE USED:

- 14 POINT (APPROX. 5/32 HIGH) FOR INSTRUCTIONS AND MAIN TITLES
- 12 POINT (APPROX. 1/8 HIGH) FOR SUB-TITLES INCLUDING "SPARES" (FOR FUSES, ETC.)
- 10 POINT (APPROX. 3/32 HIGH) FOR ELECTRICAL REFERENCE DESIGNATIONS. EXAMPLES: XV601, L601, T601, ETC.
- 36 POINT (APPROX. 3/8 HIGH) FOR CAUTION DESIGNATIONS. EXAMPLES: DANGER HIGH VOLTAGE.

Figure A-44. Specification for Marking (A2205220)

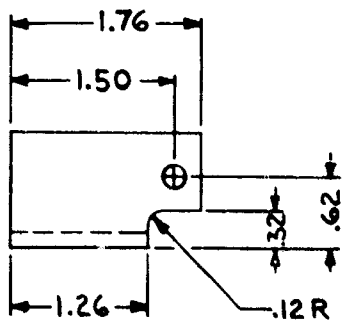
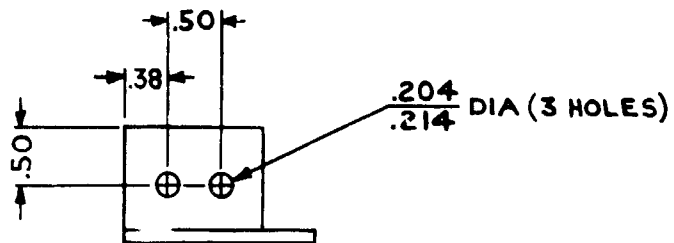

LIST OF MATERIAL

ALUMINUM, ALLOY, SHAPE, EXTR, ANGLE,
 SQ ROOT, 1" X 1" X 1/8 THK, TYPE
 6063 - T5

NOTE:

ALKALINE DIP (ROUGH ETCHED FROSTY WHITE
 FINISH) THEN APPLY PROTECTIVE COATING
 (IRILAC #1000 ALLIED RESEARCH PROP, INC.)

Figure A-45. Bracket (C2205221)

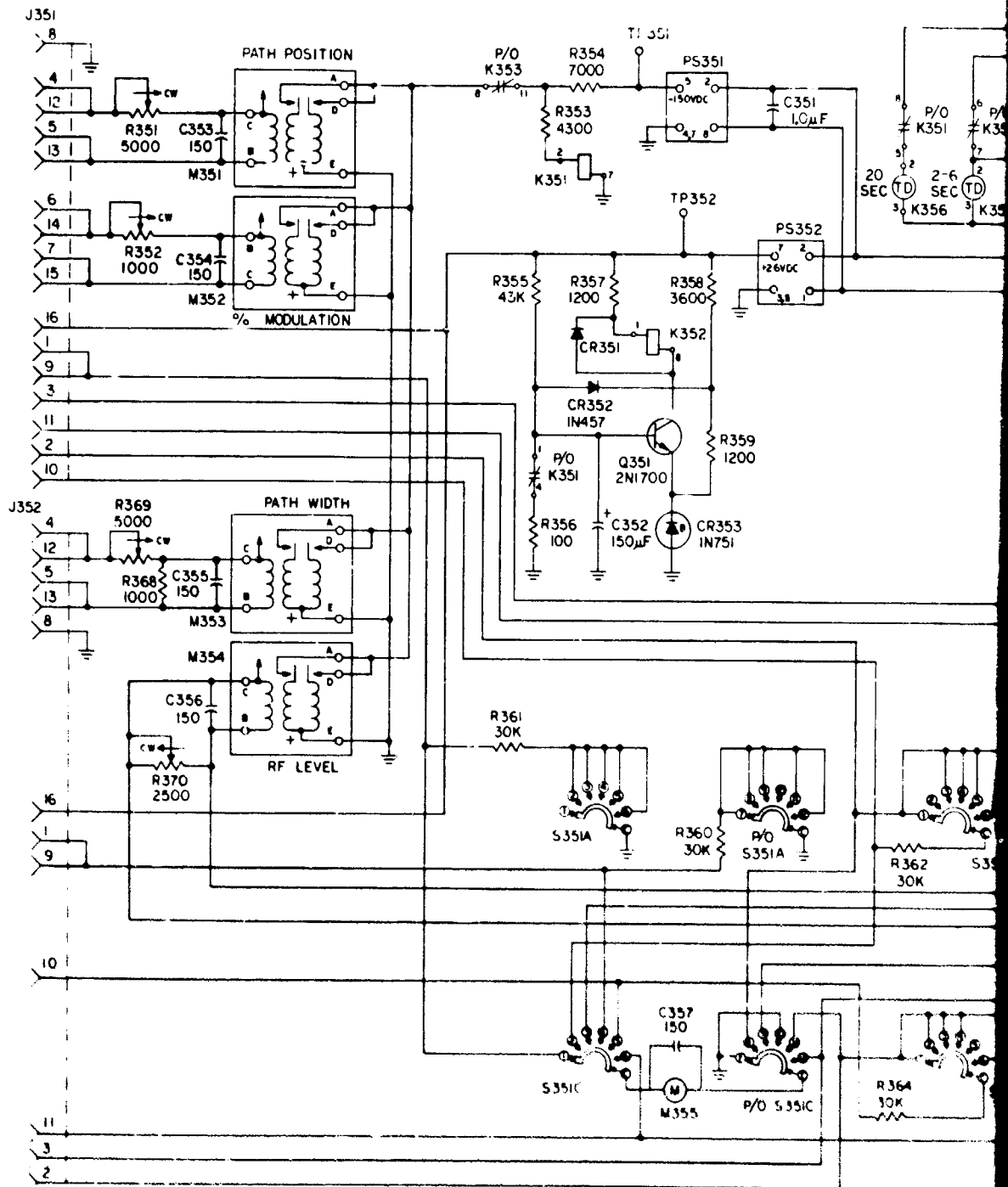

| HIGHEST REFERENCE DESIGNATIONS | | | | | |
|---------------------------------|------|------|------|------|------|
| C357 | C355 | K356 | M355 | R370 | J352 |
| REFERENCE DESIGNATIONS NOT USED | | | | | |
| | | | | | |



NOTES:

1. UNLESS OTHERWISE SPECIFIED, RESISTANCE VALUES ARE IN OHMS. CAPACITANCE VALUES ARE IN PICOFARADS.
2. TERMINAL NUMBERING FOR S351 IS FOR REFERENCE ONLY. RELATIVE LOCATION OF

TERMINAL IS SHOWN LEFT. SWITCH IS SA FRONT WITH KNOB POSITION

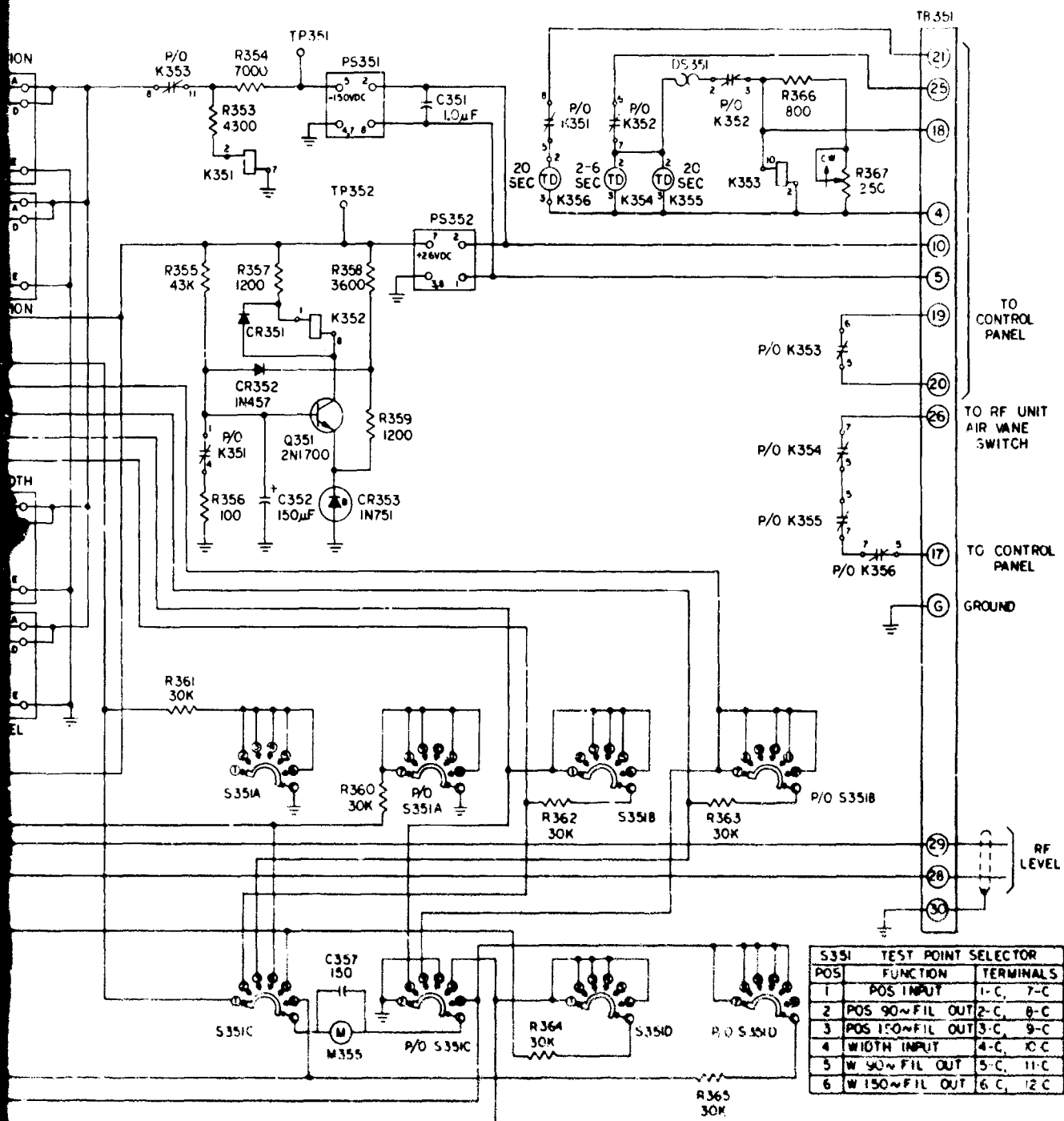

NOTES:

- UNLESS OTHERWISE SPECIFIED, RESISTANCE VALUES ARE IN OHMS. CAPACITANCE VALUES ARE IN PICOFARADS.
- TERMINAL NUMBERING FOR S351 IS FOR REFERENCE ONLY. RELATIVE LOCATION OF

TERMINAL IS SHOWN IN DIAGRAM AT LEFT. SWITCH IS SHOWN VIEWED FROM FRONT WITH KNOB IN EXTREME CCW POSITION.

Figure A-46. Schematic Diagram, Monitor Glide Slope Transmitter (E2205223)

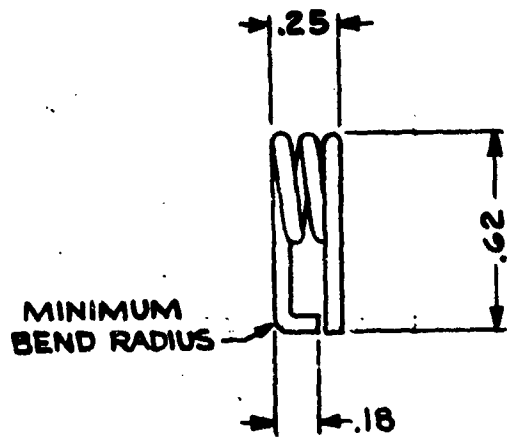

2.5 TURNS

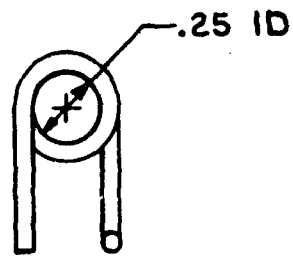

| |
|---|
| LIST OF MATERIAL |
| WIRE ELFCT. COPPER, TINNED, #16 AWG, PART NO. 910000A16 |

Figure A-47. Coil (B2205225)

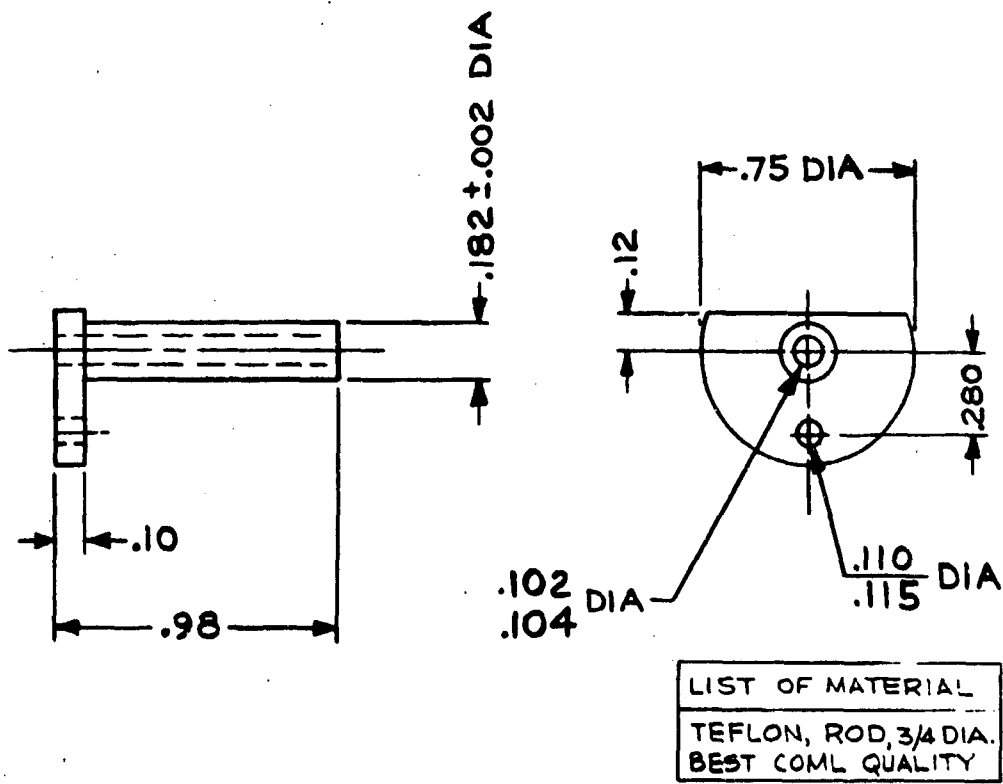
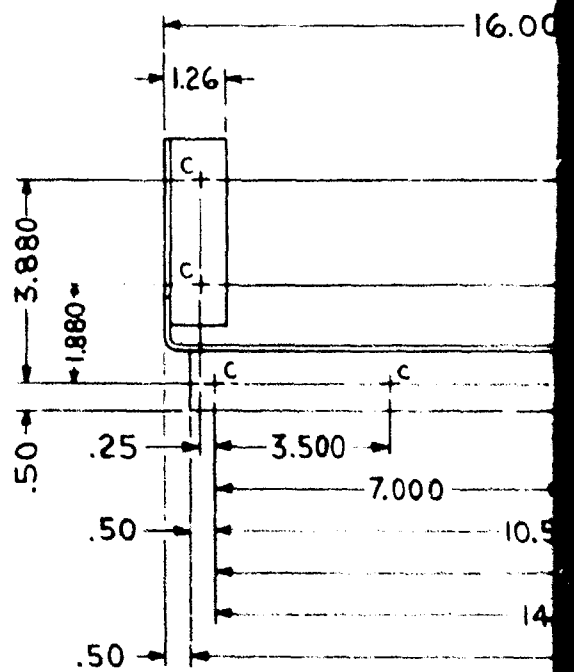
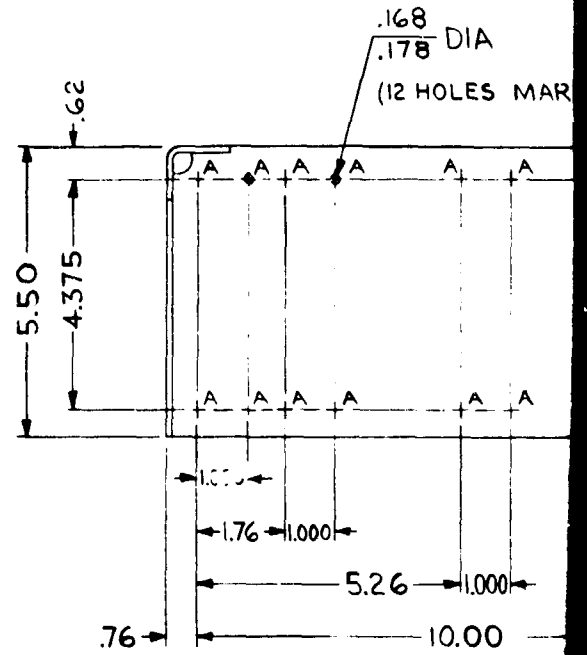
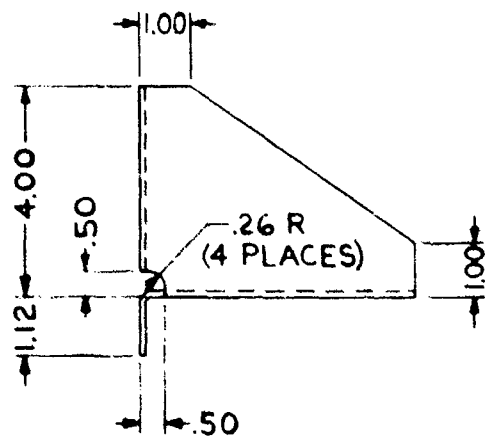
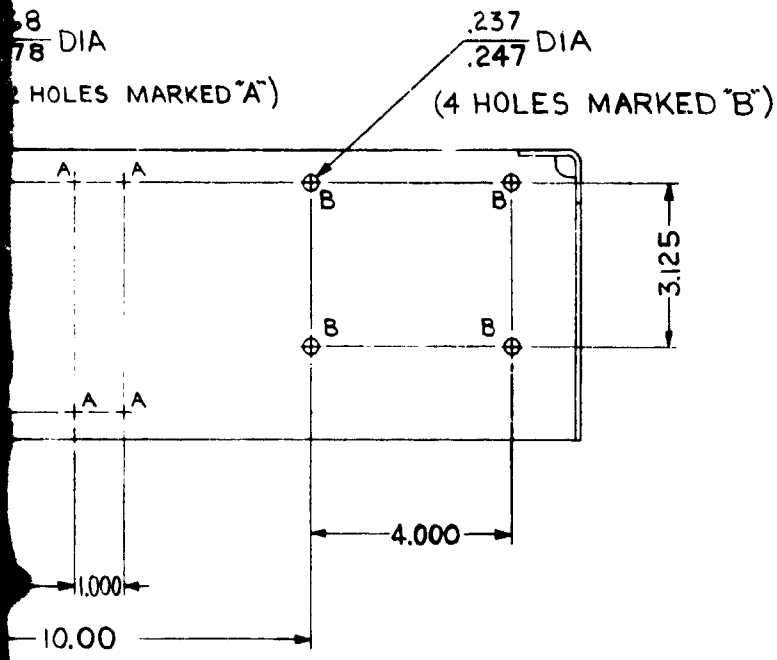

Figure A-48. Insulator (B2205226)



A



| |
|---|
| LIST OF MATERIAL |
| ALUMINUM ALLOY, SHEET .090 THK, TYPE 5052-H32 |

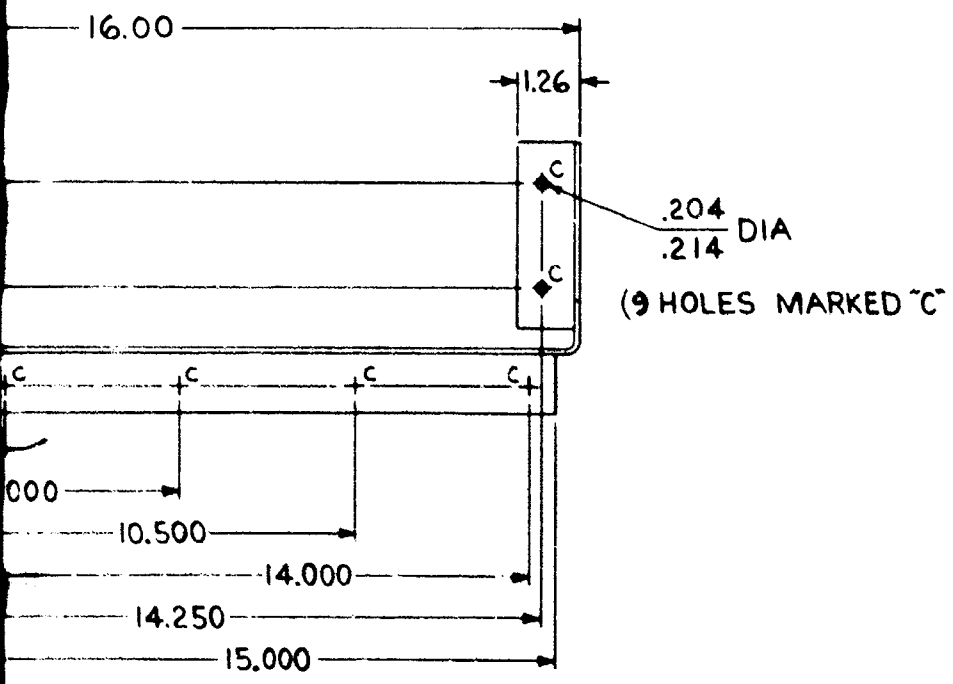

NOTE:
ALL BEND RADIUS TO BE .09

Figure A-49. Shelf (D2205227)

B

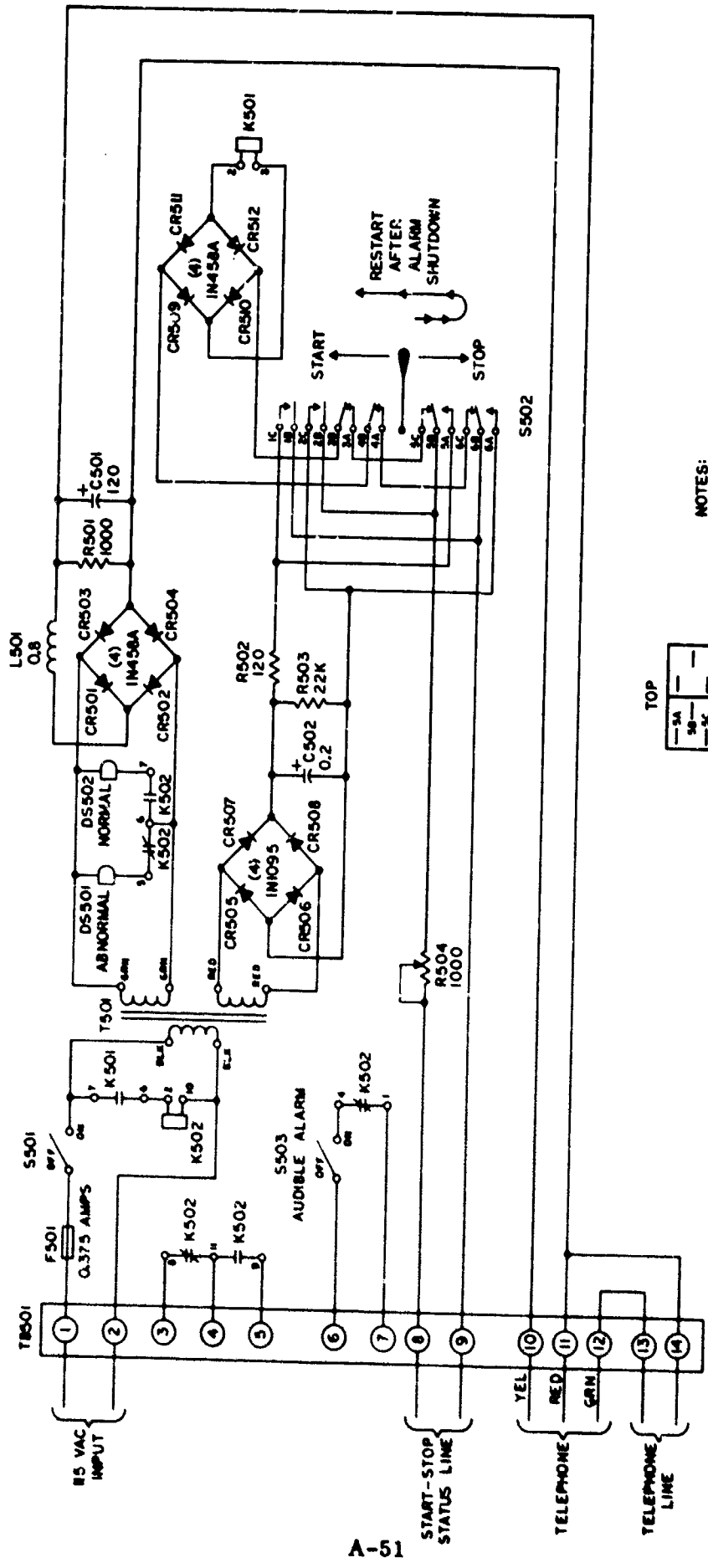

A-51

NOTES:
 UNLESS OTHERWISE SPECIFIED:
 DISTANCE VALUES ARE IN OHMS.
 CAPACITANCE VALUES ARE IN MICROFARADS.
 INDUCTANCE VALUES ARE IN HENRIES.

TOP

| | |
|----|-----|
| 1A | --- |
| 1B | --- |
| 1C | --- |
| 2A | --- |
| 2B | --- |
| 2C | --- |
| 3A | --- |
| 3B | --- |
| 3C | --- |
| 4A | --- |
| 4B | --- |
| 4C | --- |

REAR VIEW OF S502

| HIGHEST REFERENCE DESIGNATIONS | | | |
|---------------------------------|-------|------|-------|
| R504 | CR512 | S503 | D5502 |
| REFERENCE DESIGNATIONS NOT USED | | | |
| | | | |
| | | | |
| | | | |
| | | | |

Figure A-50. Schematic Diagram, Remote Control Glide Slope Transmitter (F2205228)

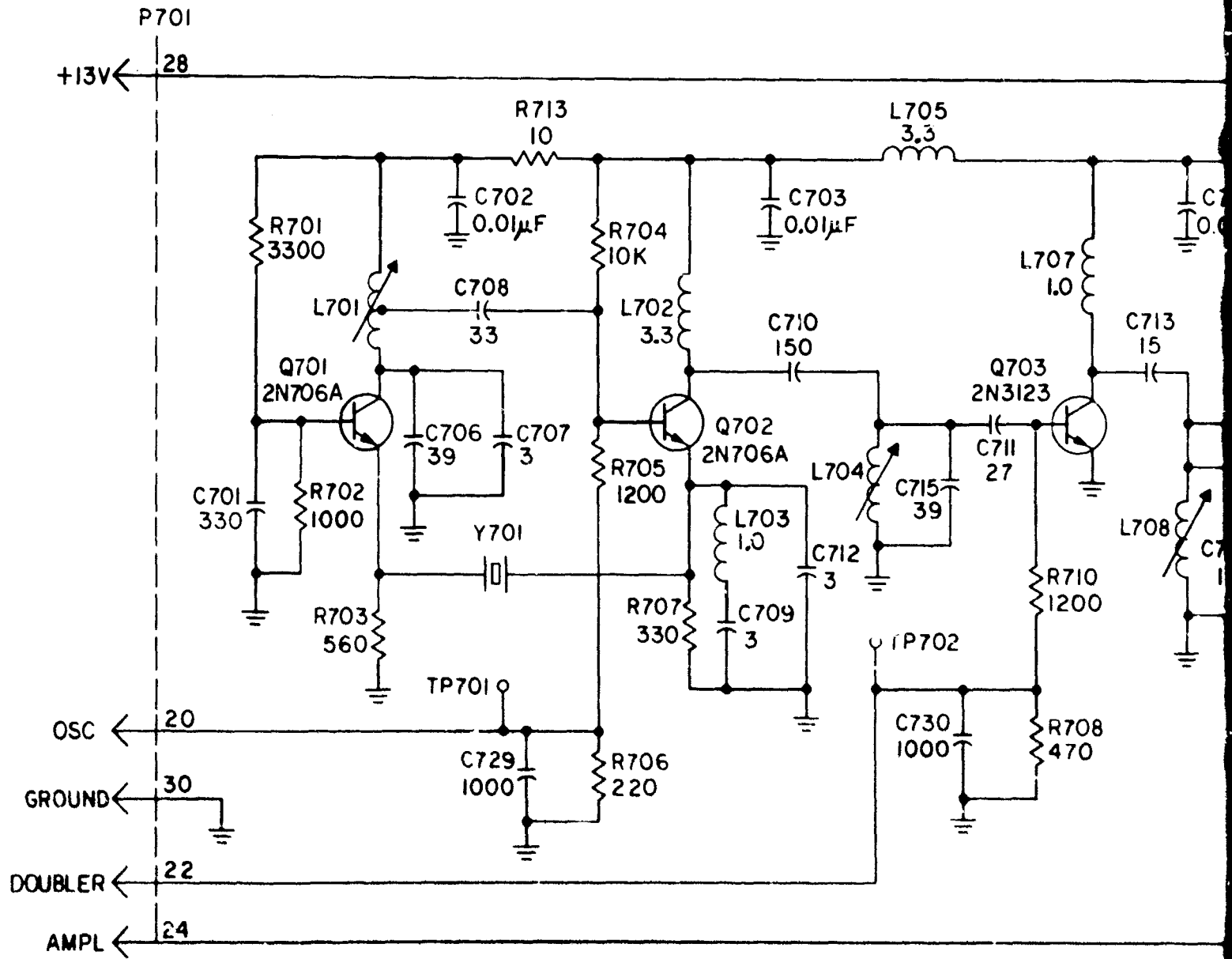

OSCILLATOR/DOUBLER

AMPLIFIER

| HIGHEST REFERENCE DESIGNATION | | | | | |
|---------------------------------|------|------|------|------|--|
| R722 | C735 | L723 | Q706 | | |
| REFERENCE DESIGNATIONS NOT USED | | | | | |
| L715 | R711 | C731 | C732 | L706 | |
| | | | | | |

A

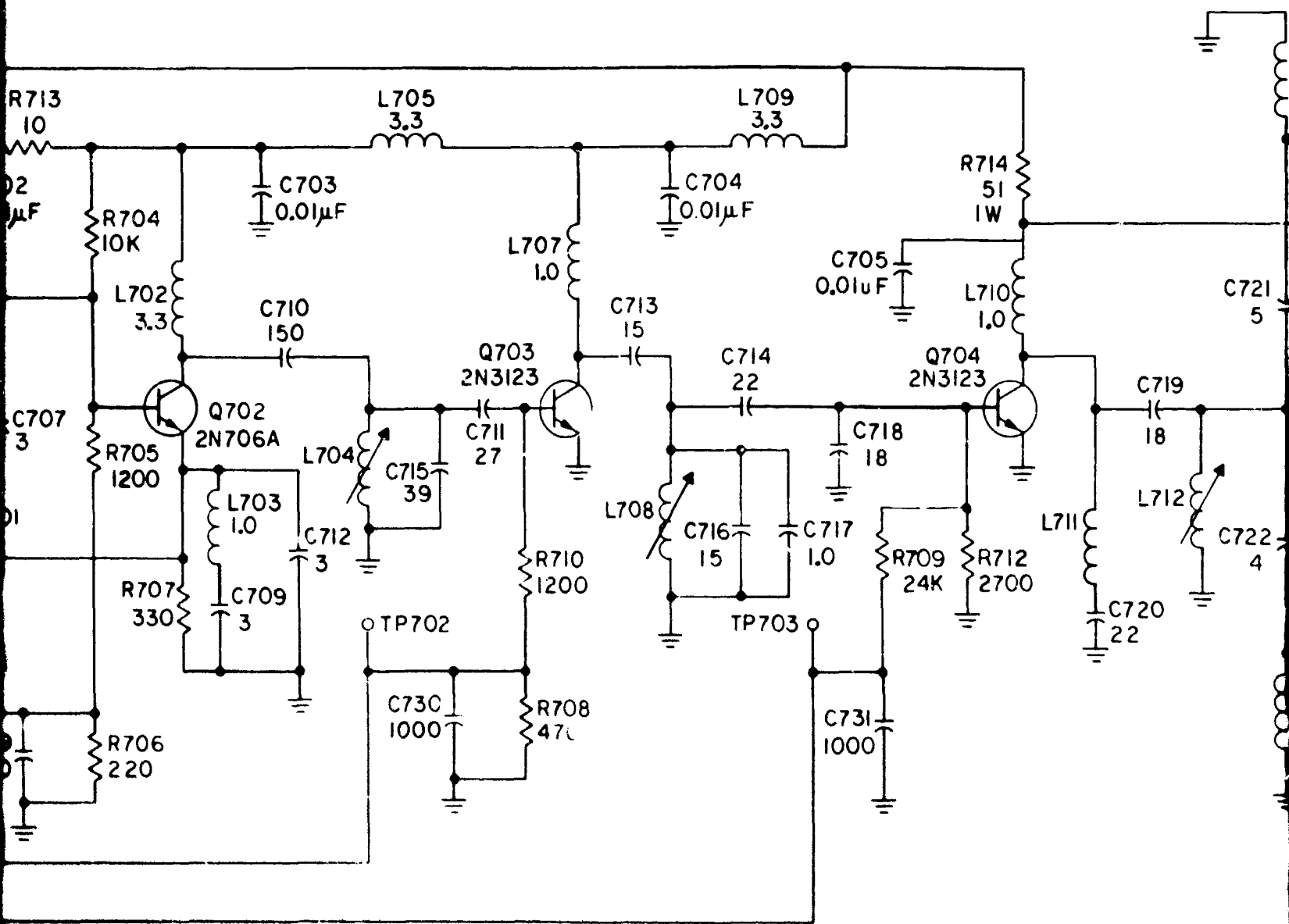

R/DOUBLER

AMPLIFIER

DOUBLER

| HIGHEST REFERENCE DESIGNATIONS | | | | | |
|---------------------------------|------|------|------|------|--|
| R722 | C735 | L723 | Q706 | | |
| REFERENCE DESIGNATIONS NOT USED | | | | | |
| L715 | R711 | C731 | C732 | L706 | |
| | | | | | |

NOTES:

- UNLESS OTHERWISE SPECIFIED, RESISTANCE VALUES ARE IN OHMS, CAPACITANCE VALUES ARE IN MICROFARADS, AND INDUCTANCE VALUES ARE IN MICROHENRS.

B

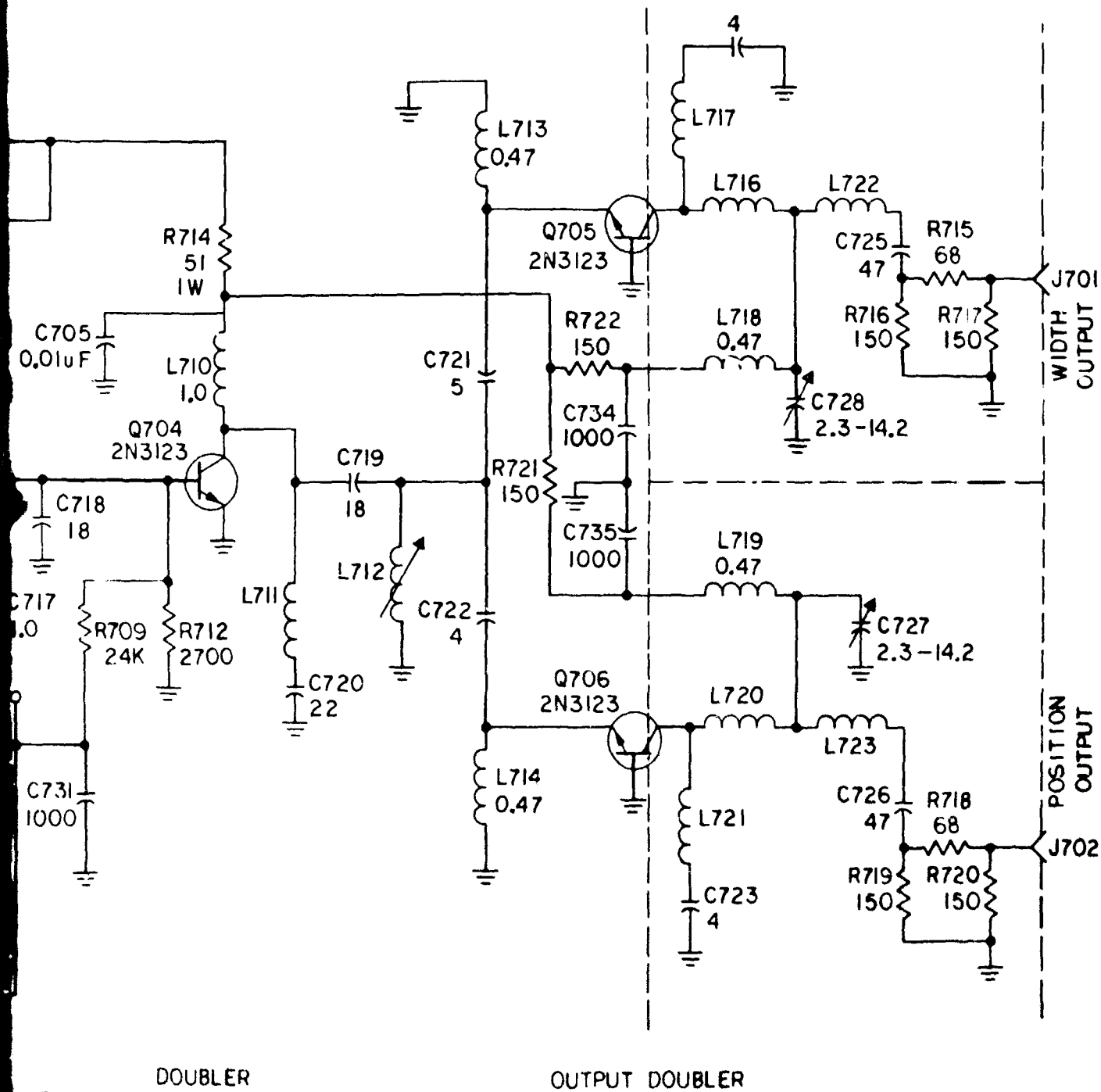

DOUBLER

OUTPUT DOUBLER

NOTES:

1. UNLESS OTHERWISE SPECIFIED:
 RESISTANCE VALUES ARE IN OHMS.
 CAPACITANCE VALUES ARE IN PICOFARADS.
 INDUCTANCE VALUES ARE IN MICROHENRIES

Figure A-51. Schematic Diagram,
 Local Oscillator GS Field Detector
 (E2205230)

c

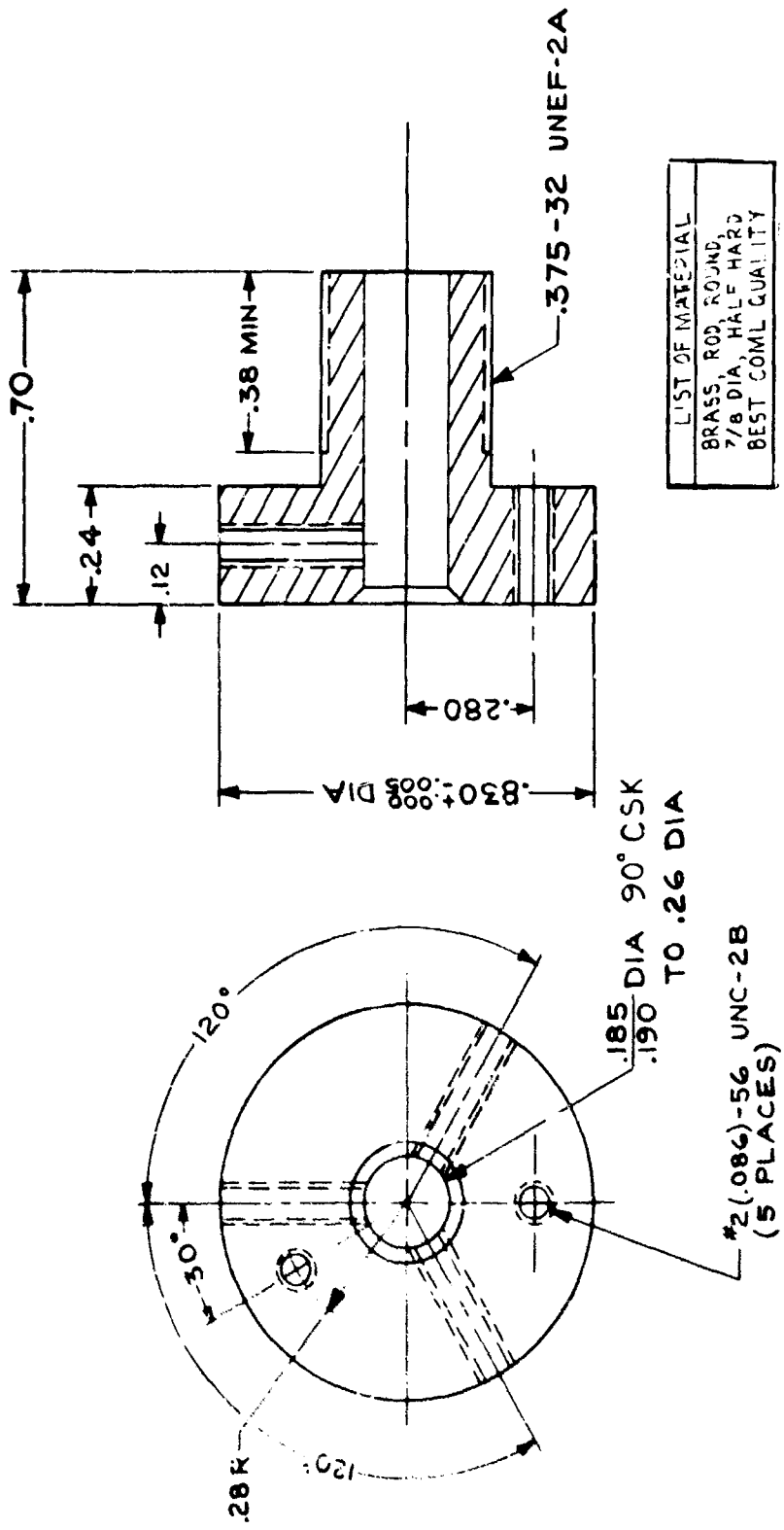
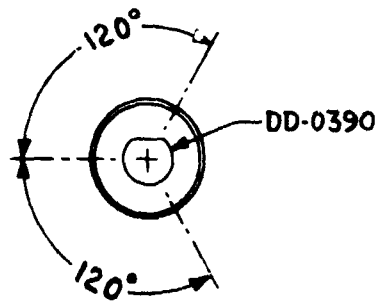
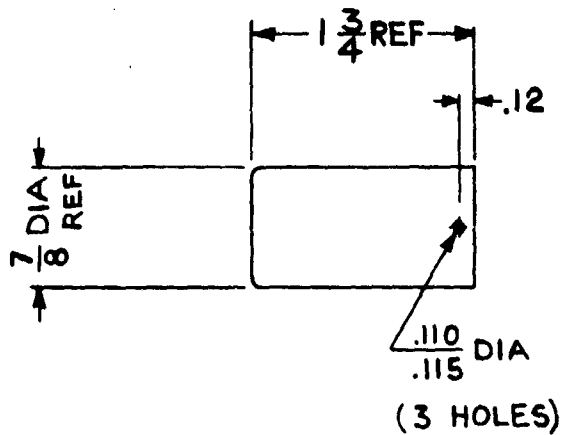

Figure A-52. Bushing (C2205231)

| |
|---------------------|
| LIST OF MATERIAL |
| ALUMINUM |
| (VENDOR'S STANDARD) |

NOTE:
ALL REF DIMENSIONS ARE
VENDOR'S DIMENSIONS.



VENDOR:
 HUDSON TOOL & DIE COMPANY, INC.
 NEWARK 5, NEW JERSEY
 PART NO. HU-7-1

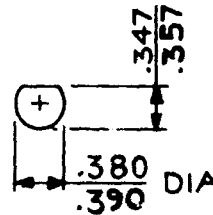

DD-0390

Figure A-53. Cable, Round (Modified) (B2205233)

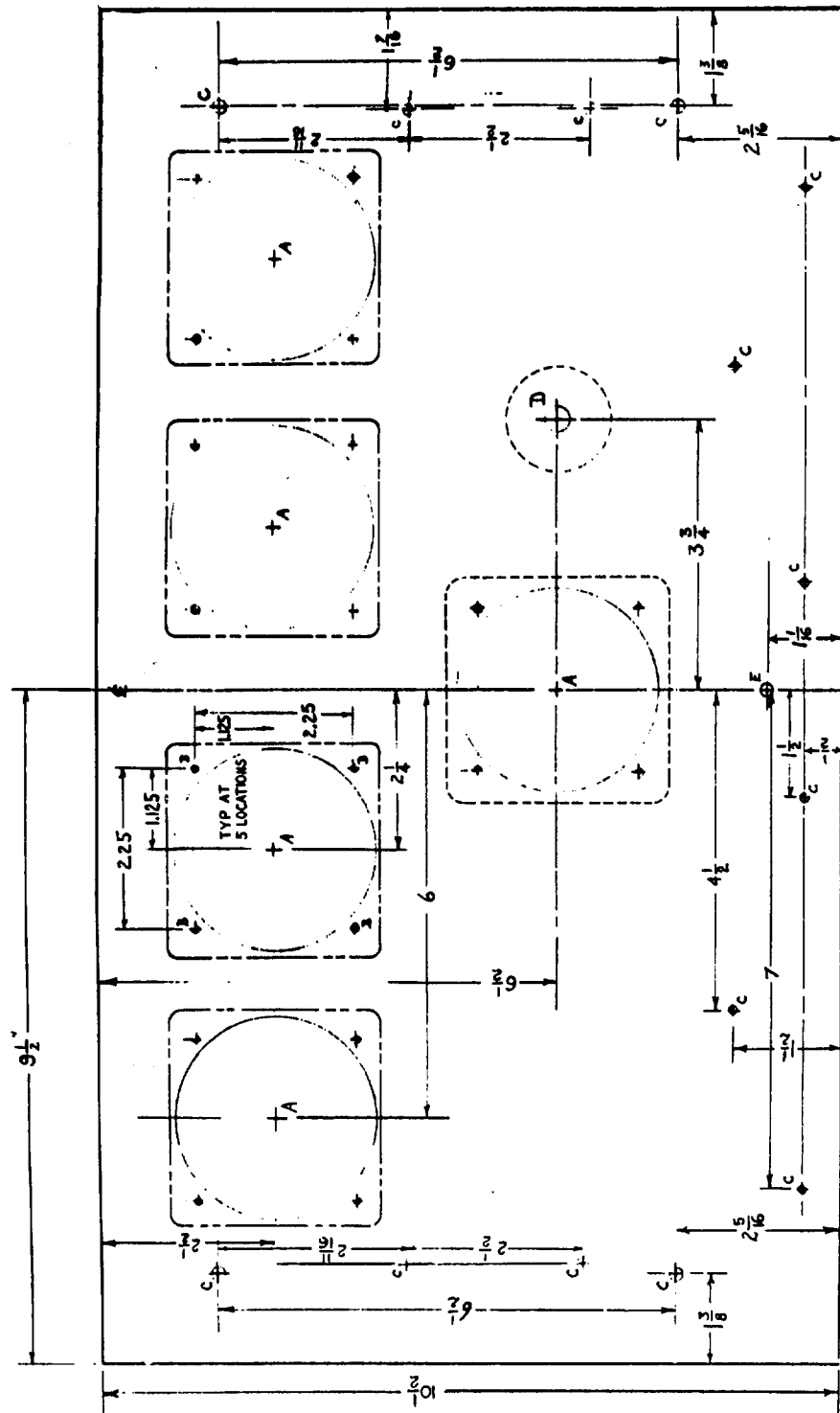

Holes:

| | |
|---|-------------|
| A | = 2.81 dia |
| B | = 0.125 dia |
| C | = 0.199 dia |
| D | = 0.391 dia |
| E | = 0.250 dia |

Figure A-54. Monitor Front Panel Drilling (C2205241)

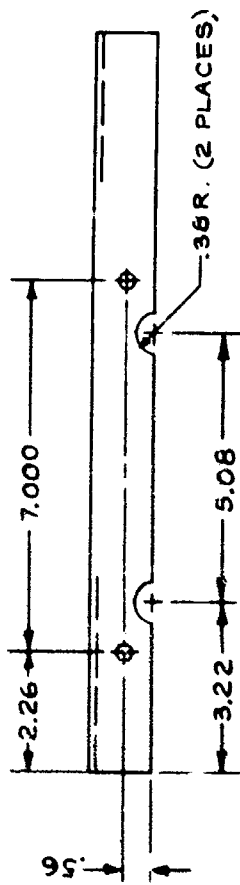
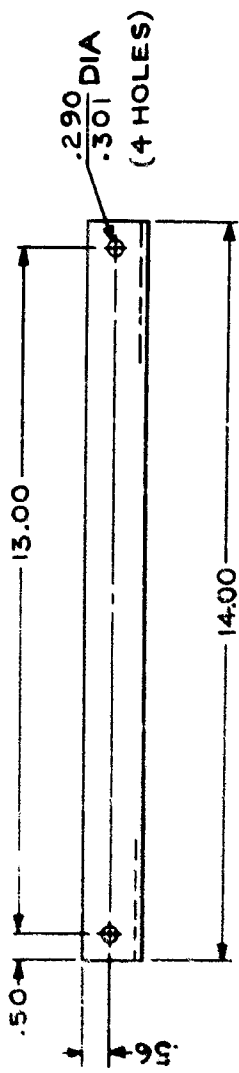

| LIST OF MATERIAL | |
|--------------------------|--|
| ALUMINUM, ALLOY | |
| SHAPE, EXTR, ANGLE, | |
| SQ ROOT, 1 1/4 X 1 1/2 X | |
| 1/8 THK, TYPE 6063-T5 | |

| PART NO. | DESCRIPTION |
|-----------|---------------|
| 2205243G1 | AS SHOWN |
| 2205243G2 | OPPOSITE HAND |

A-56

Figure A-55. Angle (C2205243)

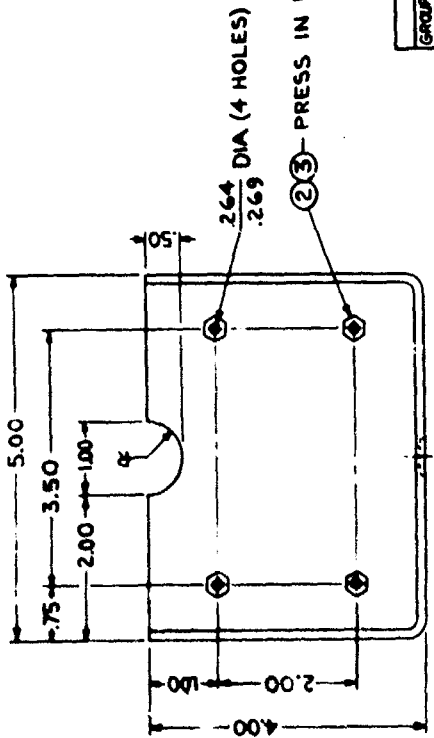

②③—PRESS IN FROM THIS SIDE

| GROUP QTY NUMBER | | PART OR IDENTIFYING NO. | | LIST OF MATERIAL | | NOMENCLATURE OR DESCRIPTION | |
|------------------|---|-------------------------|---|------------------|----------------------------------|-----------------------------|--|
| 63152851 | M | 20 | 3 | PE2016 | INSTALLATION INSTRUCTIONS TRD | | |
| | | | | | INSERT | | |
| | | | | | ALUMINUM TUBES ADDED #10 (20)-52 | | |
| | | | | | ALUM. ALLOY SHEET 1/16 THK TYPE | | |
| | | | | | 5052-H32 | | |

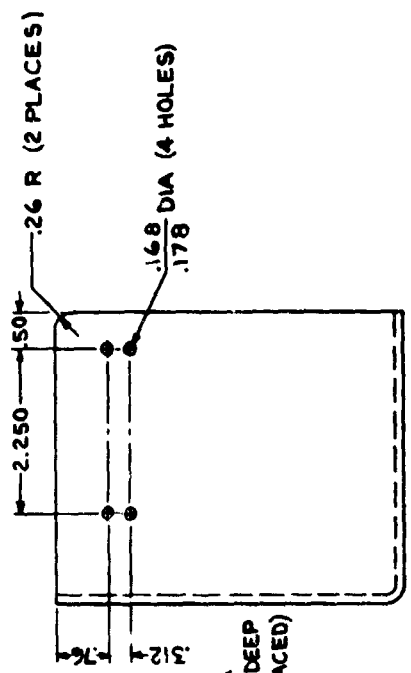
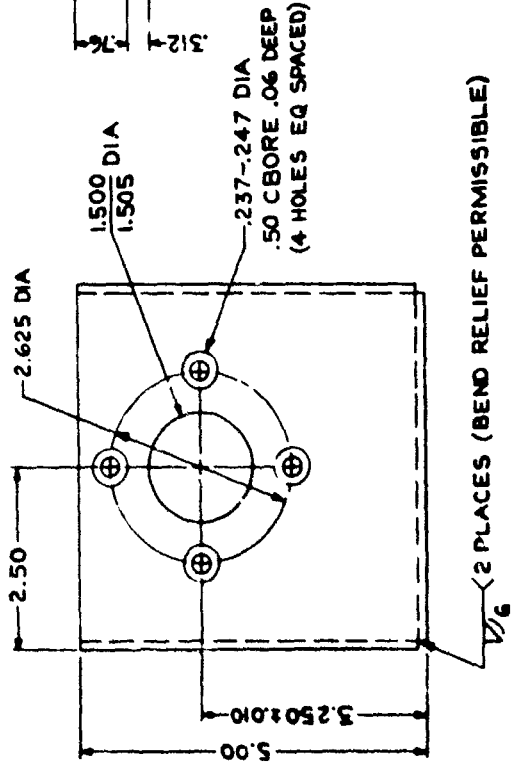

NOTE:
ALL BEND RADII TO BE .12

Figure A-56. Bracket (D2205244)

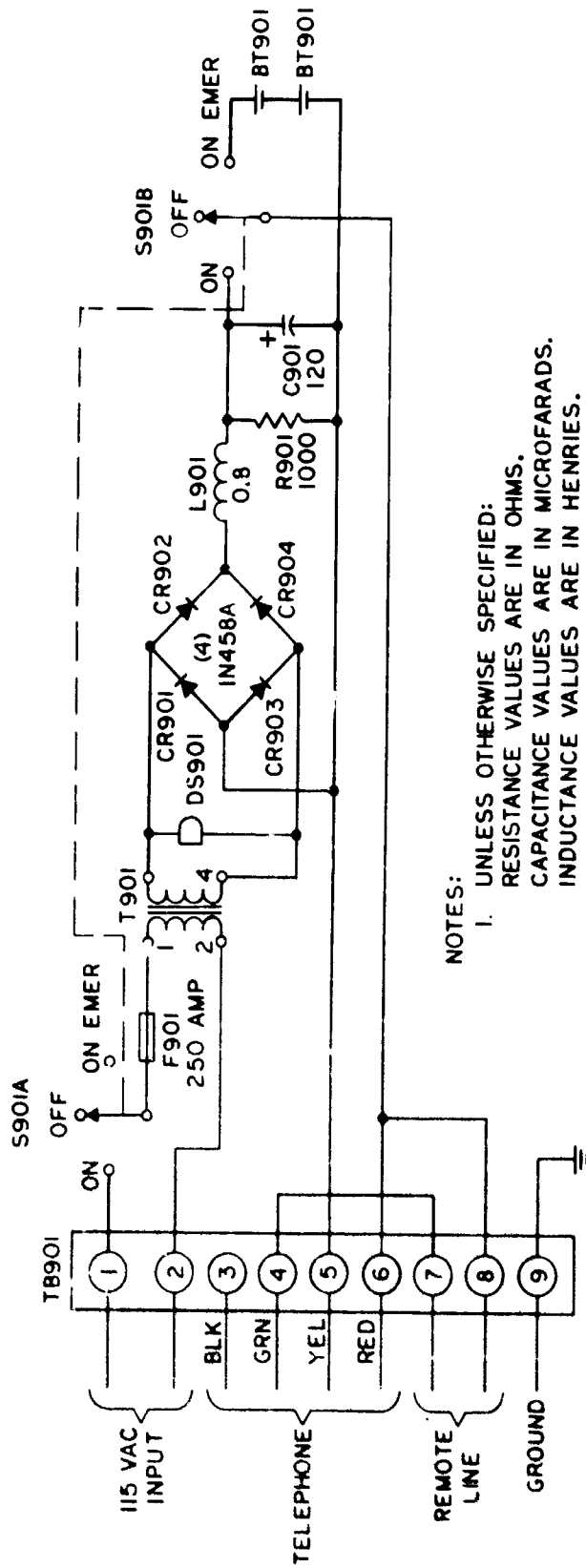

NOTES:

1. UNLESS OTHERWISE SPECIFIED:
RESISTANCE VALUES ARE IN OHMS.
CAPACITANCE VALUES ARE IN MICROFARADS.
INDUCTANCE VALUES ARE IN HENRIES.

Figure A-57. Schematic Diagram, Telephone Power Supply (Shelter)
(D2205245)

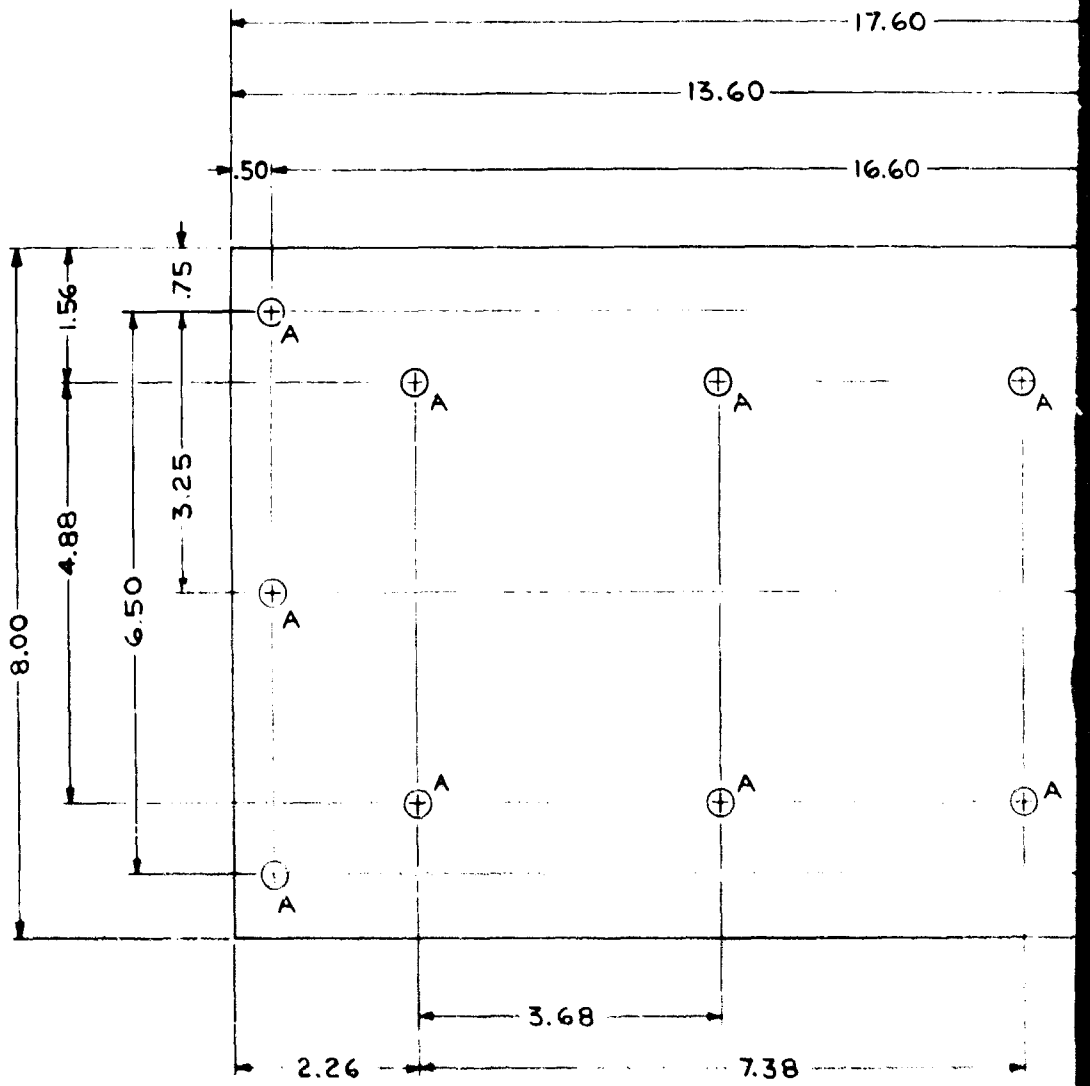

A

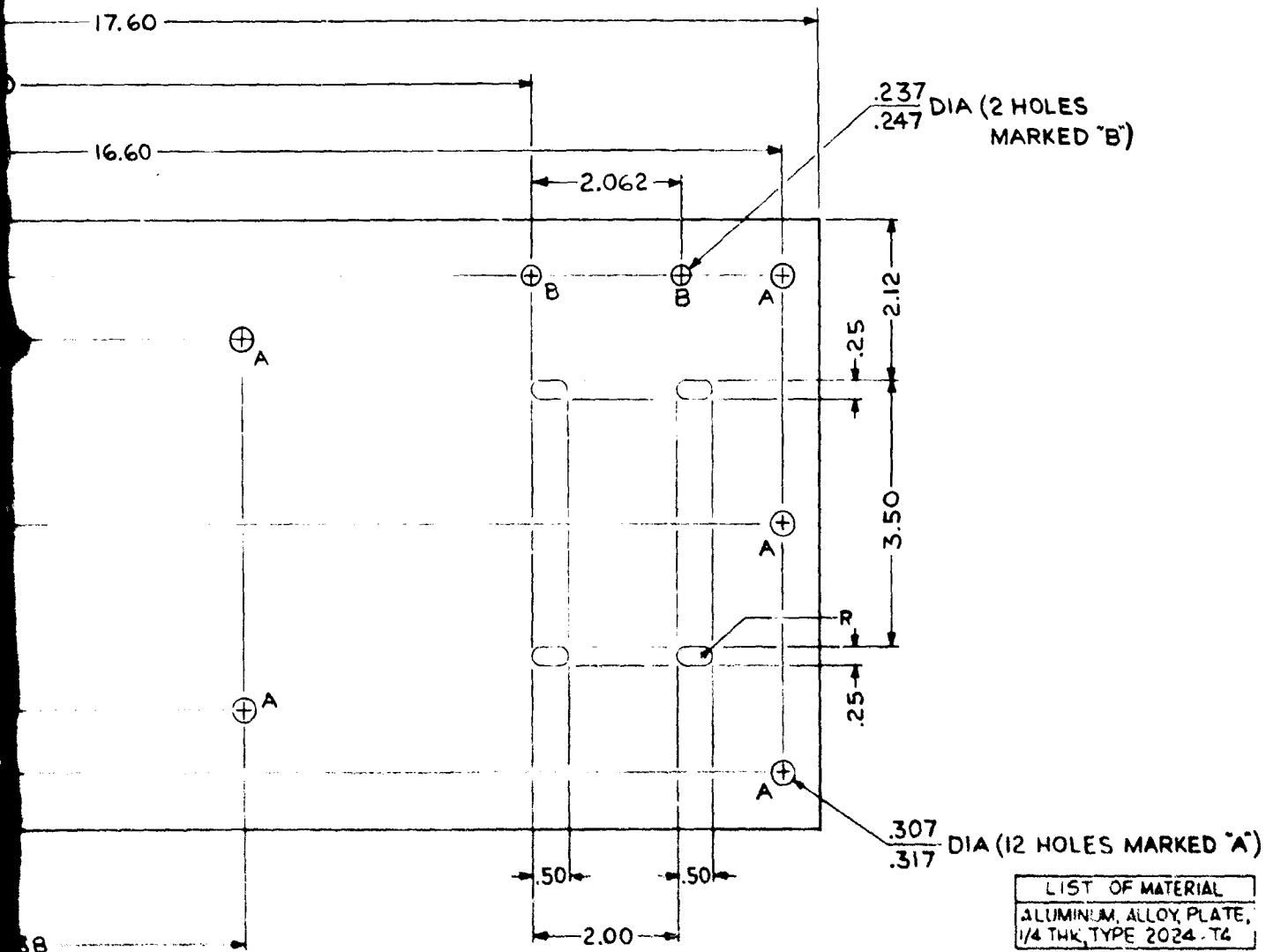
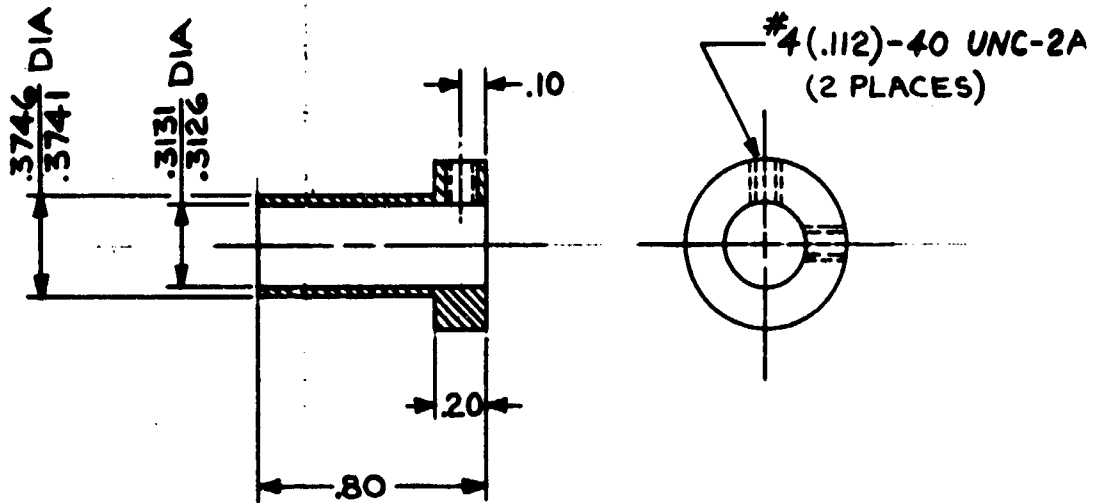

Figure A-58. Plate (D2205249)

B

A-59



| LIST OF MATERIAL |
|--|
| STEEL, CRE, ROD, ROUND, 5/8 DIA, ANL., AISI 303, PER QQ-S-763, CLAS 7, COND A |

Figure A-59. Adapter, Shaft (B2205250)

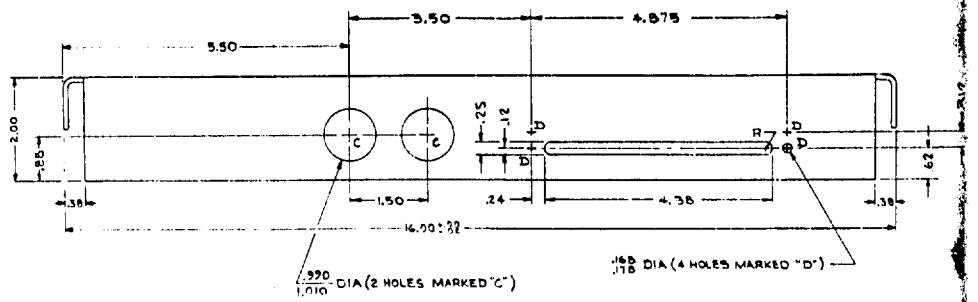
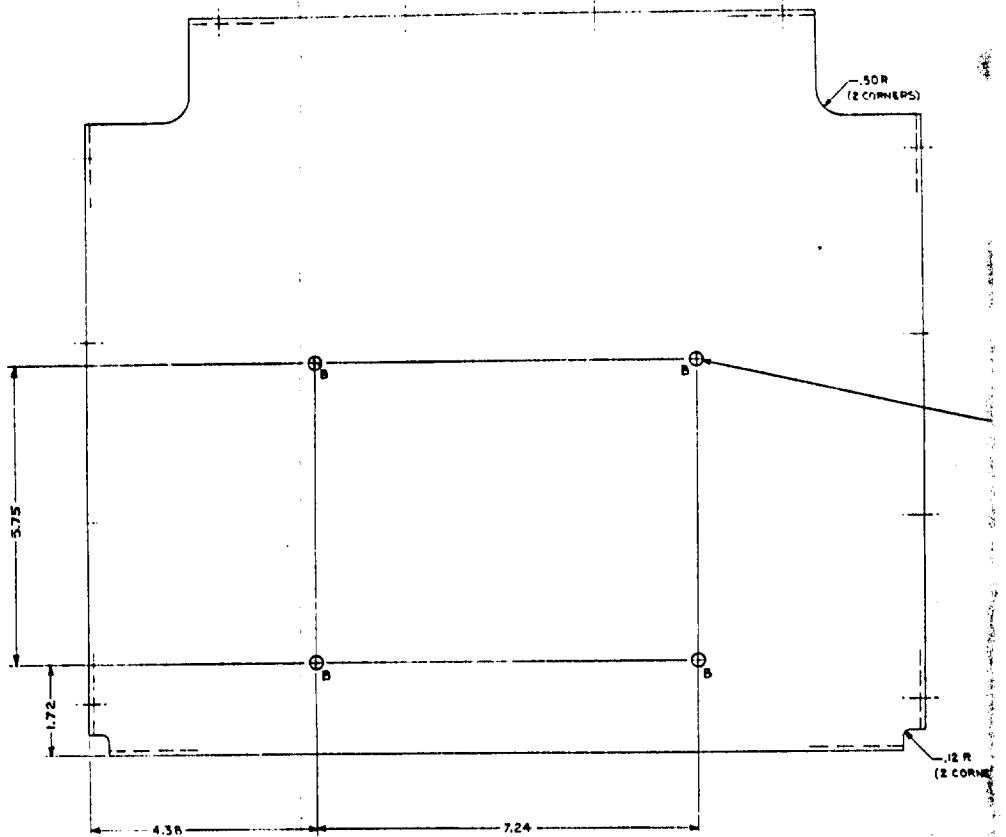
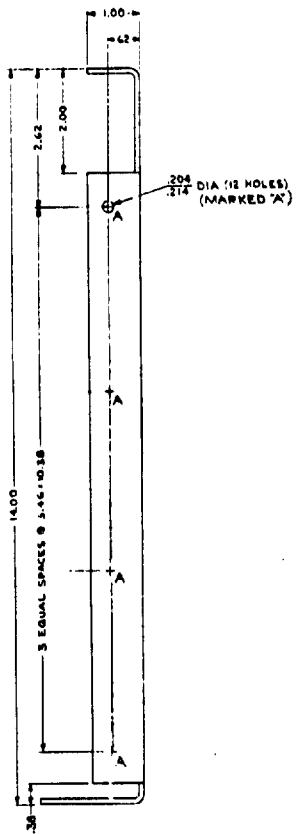
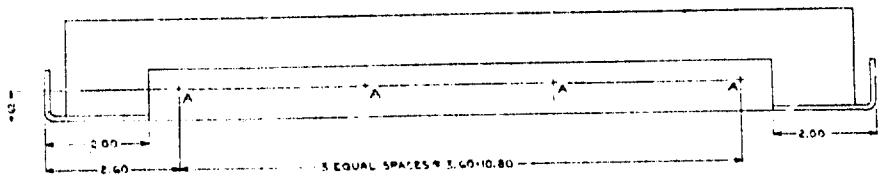

A

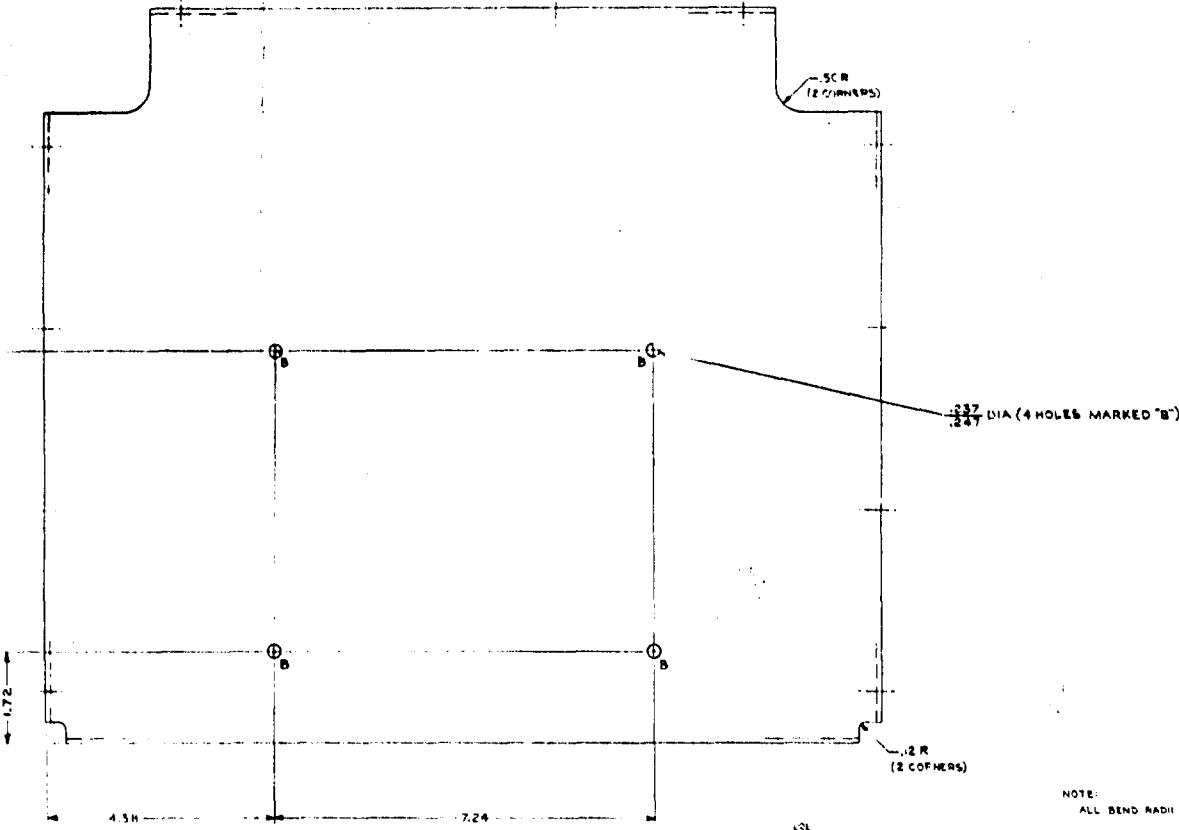
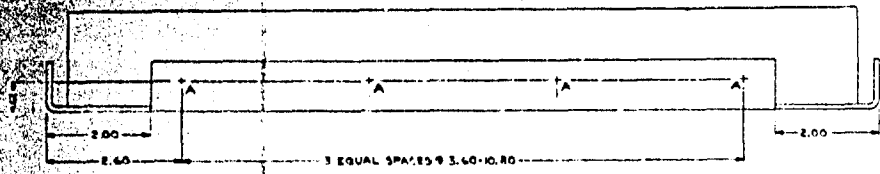

NOTE:
ALL BEND RADI TO BE .09

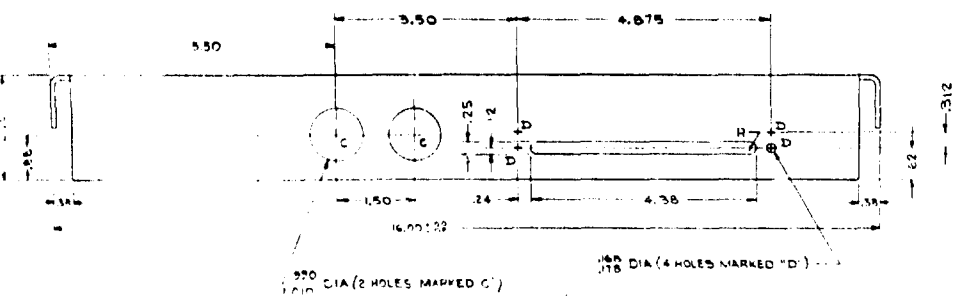

FINISH:
ALKALINE DIP (ROUGH ETCHED FROSTY-WHITE FINISH) THEN APPLY PROTECTIVE COATING (IRILAC 1000 ALLIED RESEARCH PROD, INC)

| LIST OF MATERIAL | |
|----------------------|-----------------------|
| ALUMINUM ALLOY SHEET | QWV-T42, TYPE 3003H14 |

Figure A-60. Shelf (E2205251)

A-61

B

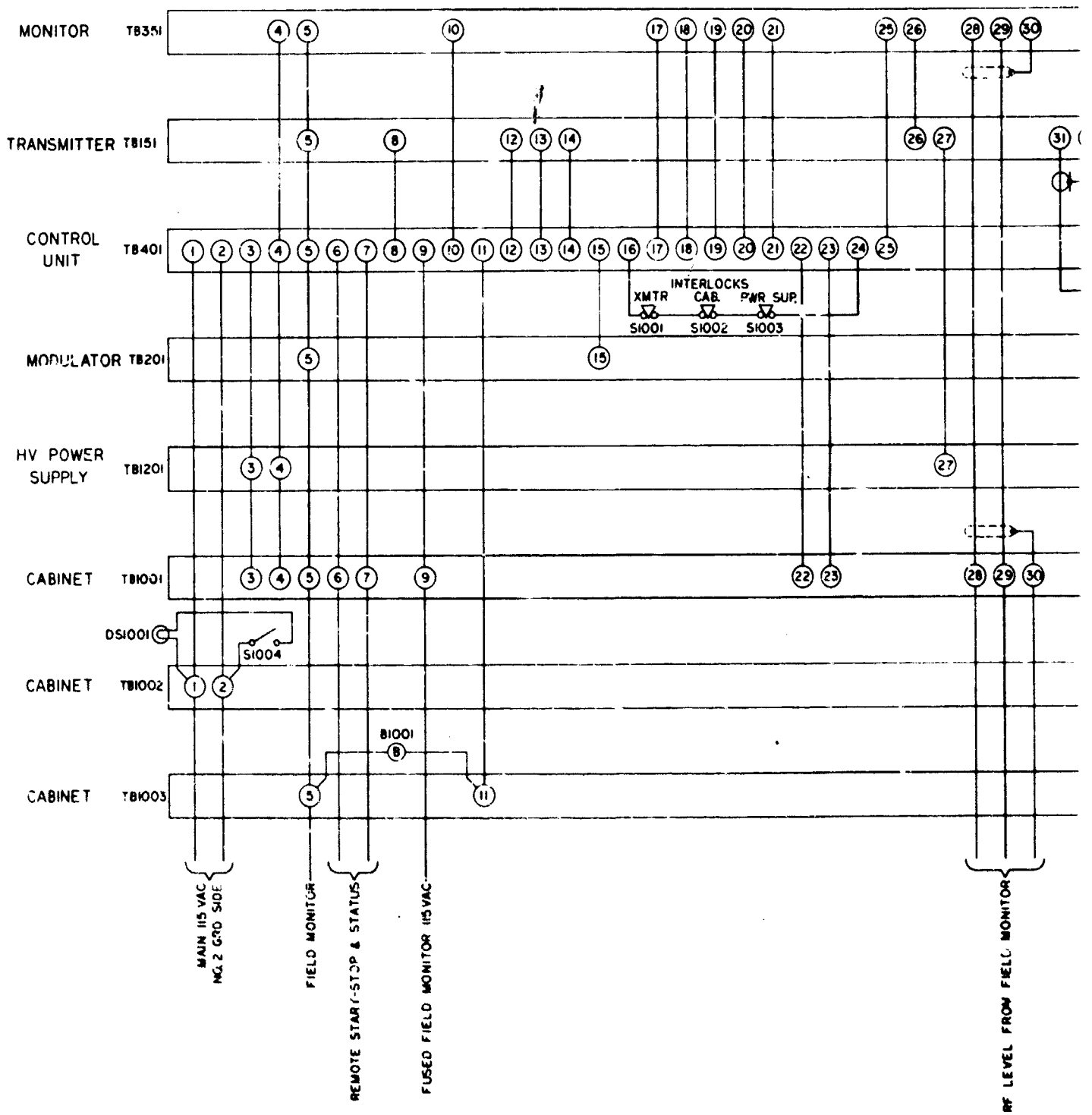

A

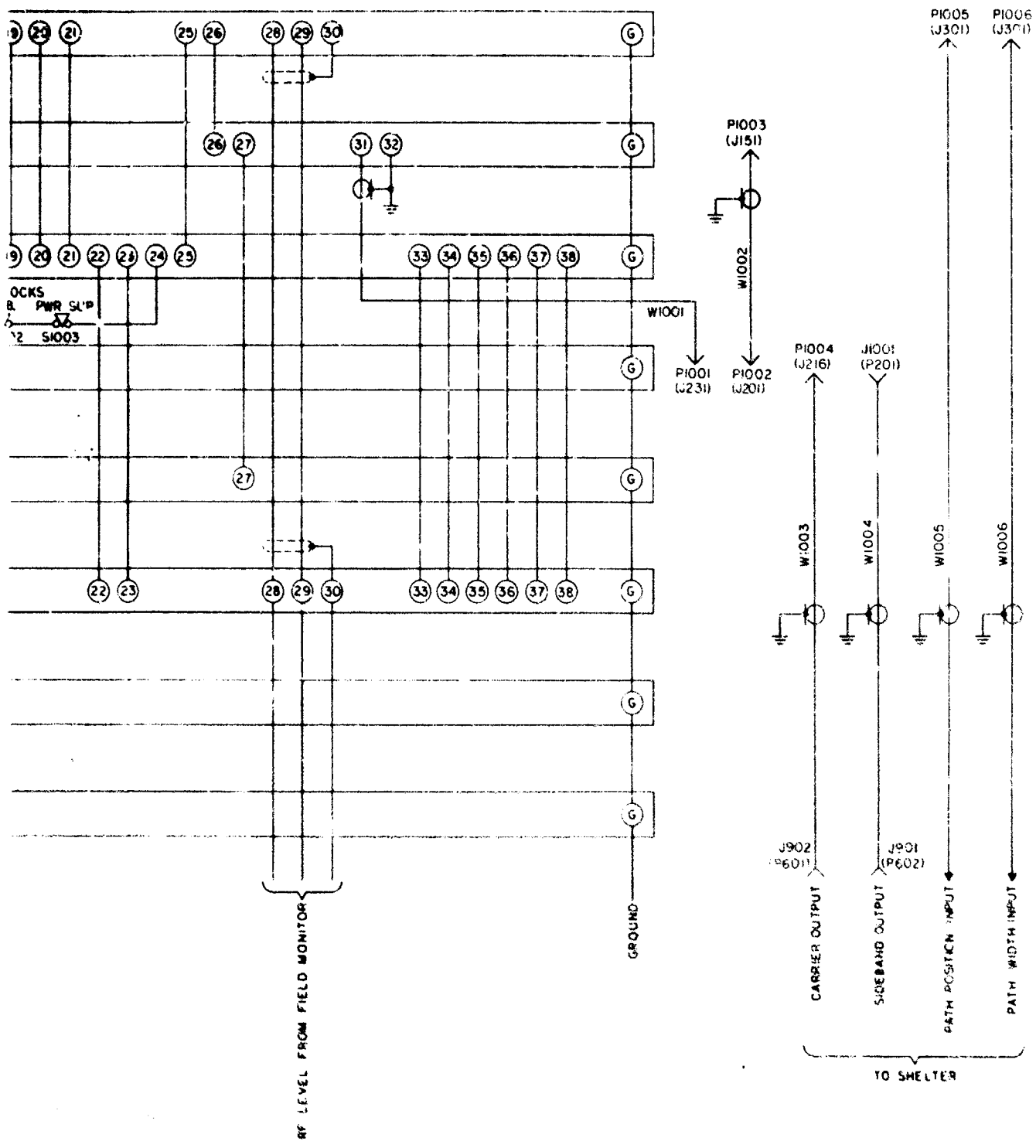
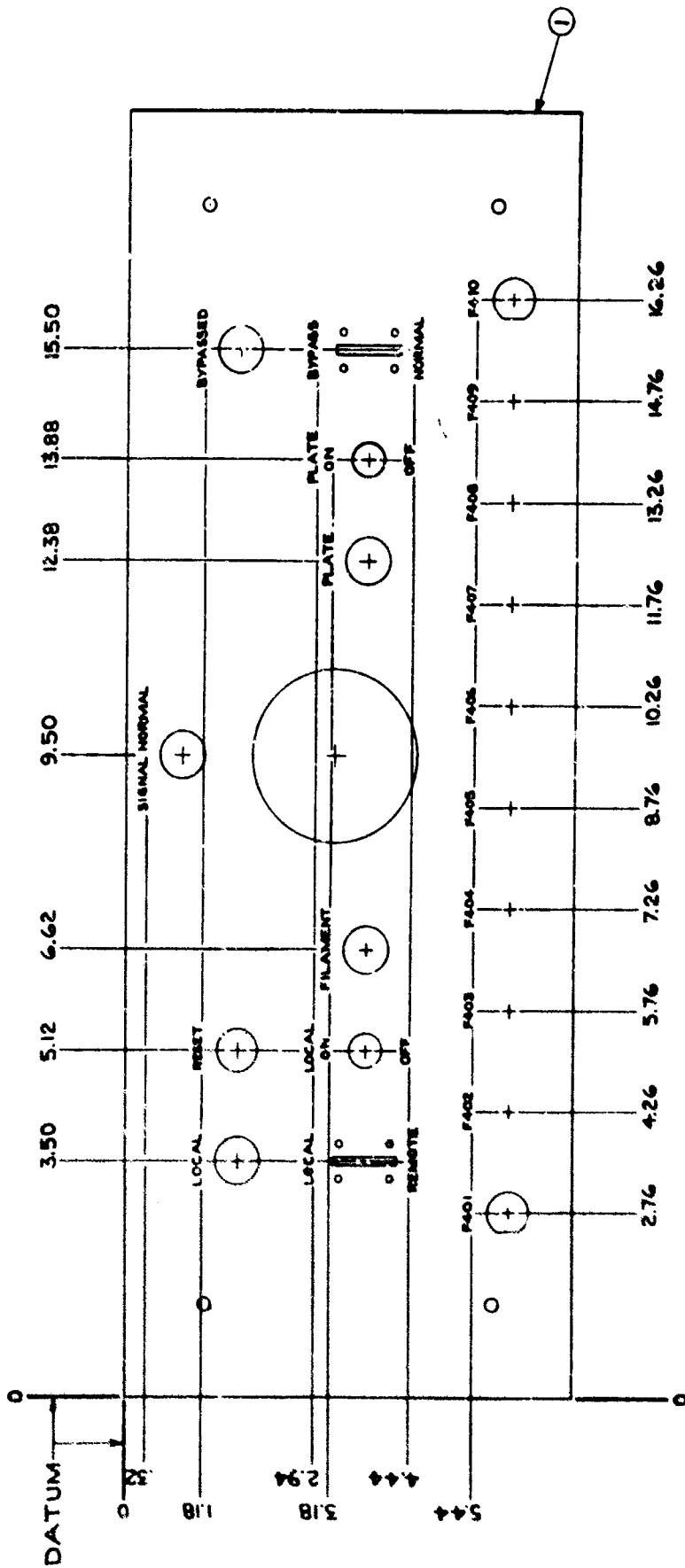

Figure A-61. Schematic Diagram, Intra Cabinet Wiring Glide Slope Transmitter (J2205252)

B



A-63

- NOTES:
1. MARK PER A2205220 PARA 'B', PAINT TO BE BLACK IN COLOR.
 2. CHARACTERS TO BE 12 POINT UNLESS OTHERWISE SPECIFIED, / CENTRALLY LOCATED AS SHOWN.

Figure A-62. Panel, Front (Marking) (D22052-3)

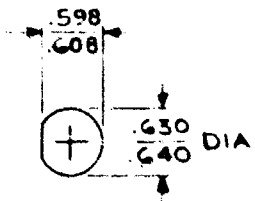
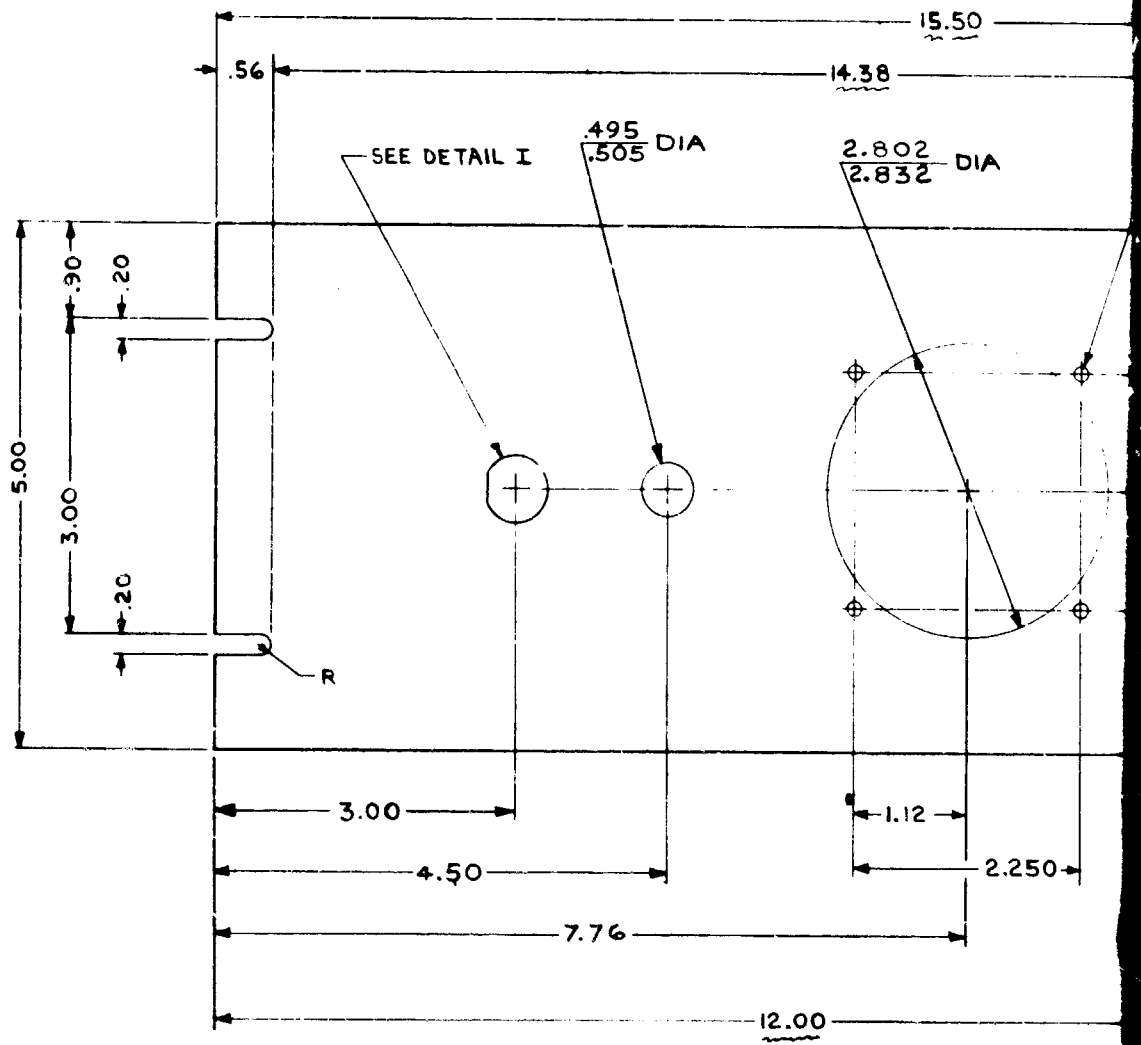

DD-0640

DETAIL I

A

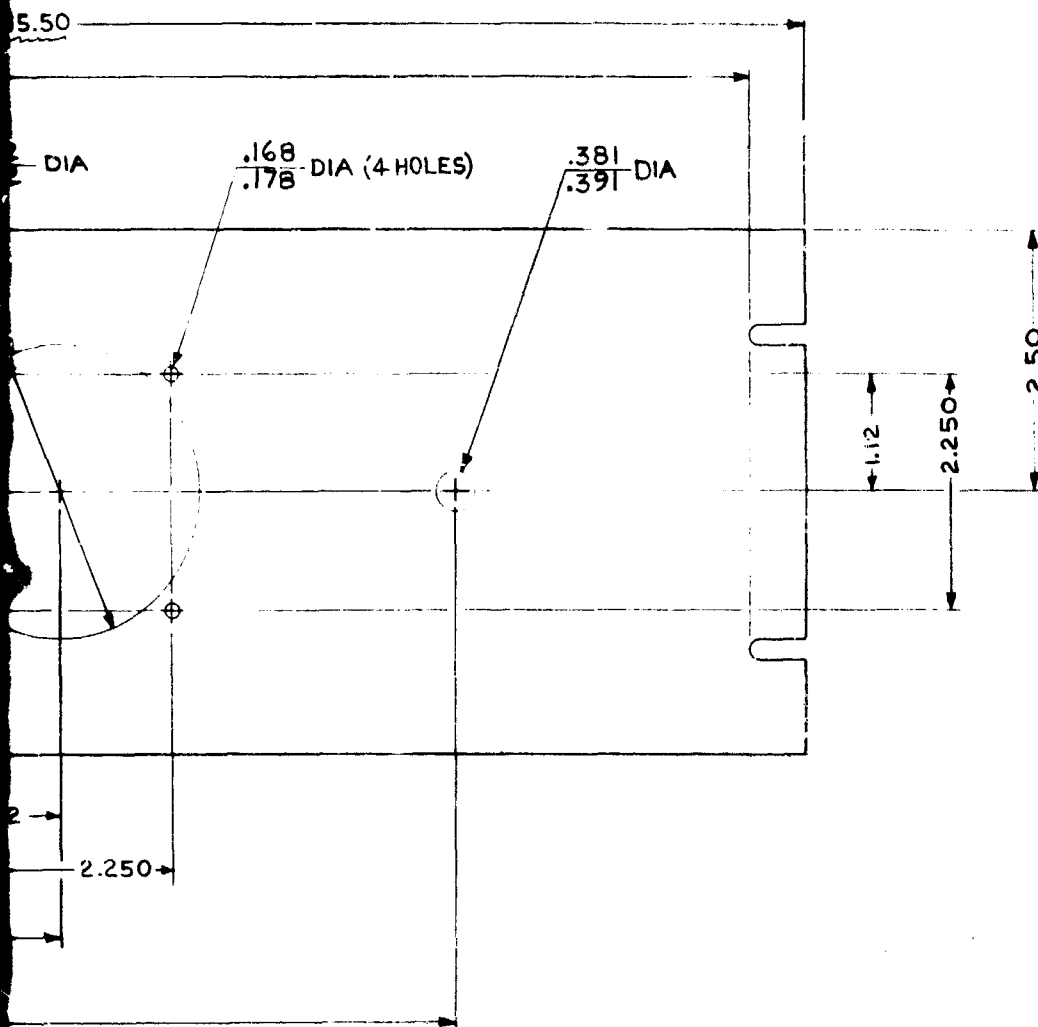

| |
|-------------------------|
| LIST OF MATERIAL |
| ALUMINUM ALLOY SHEET |
| .125 THK, TYPE 5052-H34 |

FINISH:
 ALKALINE DIP (ROUGH ETCHED FROSTY-WHITE
 FINISH) THEN APPLY PROTECTIVE COATING
 (IRILAC #1000 ALLIED RESEARCH PROP, INC)

Figure A-63. Panel, Meter (Drilling)
 (D2205254)

B

A-64

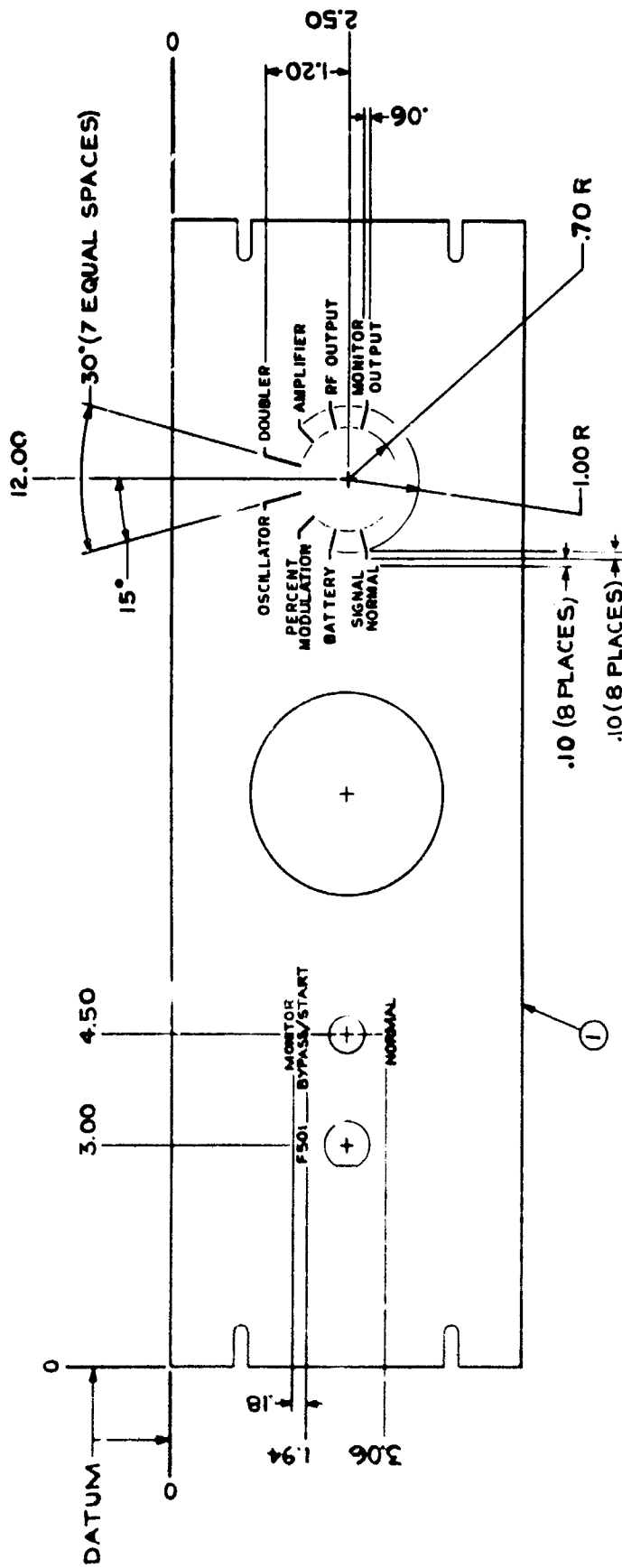

A-65

NOTES:

1. MARK PER A2205220 PARA 'B'.
PAINT TO BE BLACK IN COLOR.
2. CHARACTERS TO BE 12 POINT
UNLESS OTHERWISE SPECIFIED
‡ CENTRALLY LOCATED AS SHOWN.
3. ALL LINES TO BE .03 THK.

| GROUP QTY | | UPTER | | LIST OF MATERIAL | | | |
|-----------|----|-------|---|------------------|-----------------|-----------|-----------------------------|
| G3 | G2 | G1 | M | NO. | IDENTIFYING NO. | PAR OR | NOMENCLATURE OR DESCRIPTION |
| | | | | 20 | 2 | 2205220 | SPECIFICATION FOR MARKING |
| | | | | 1 | 1 | 220525461 | PANEL METER (DRILLING) |

Figure A-64. Panel, Meter (Marking) (D2205255)

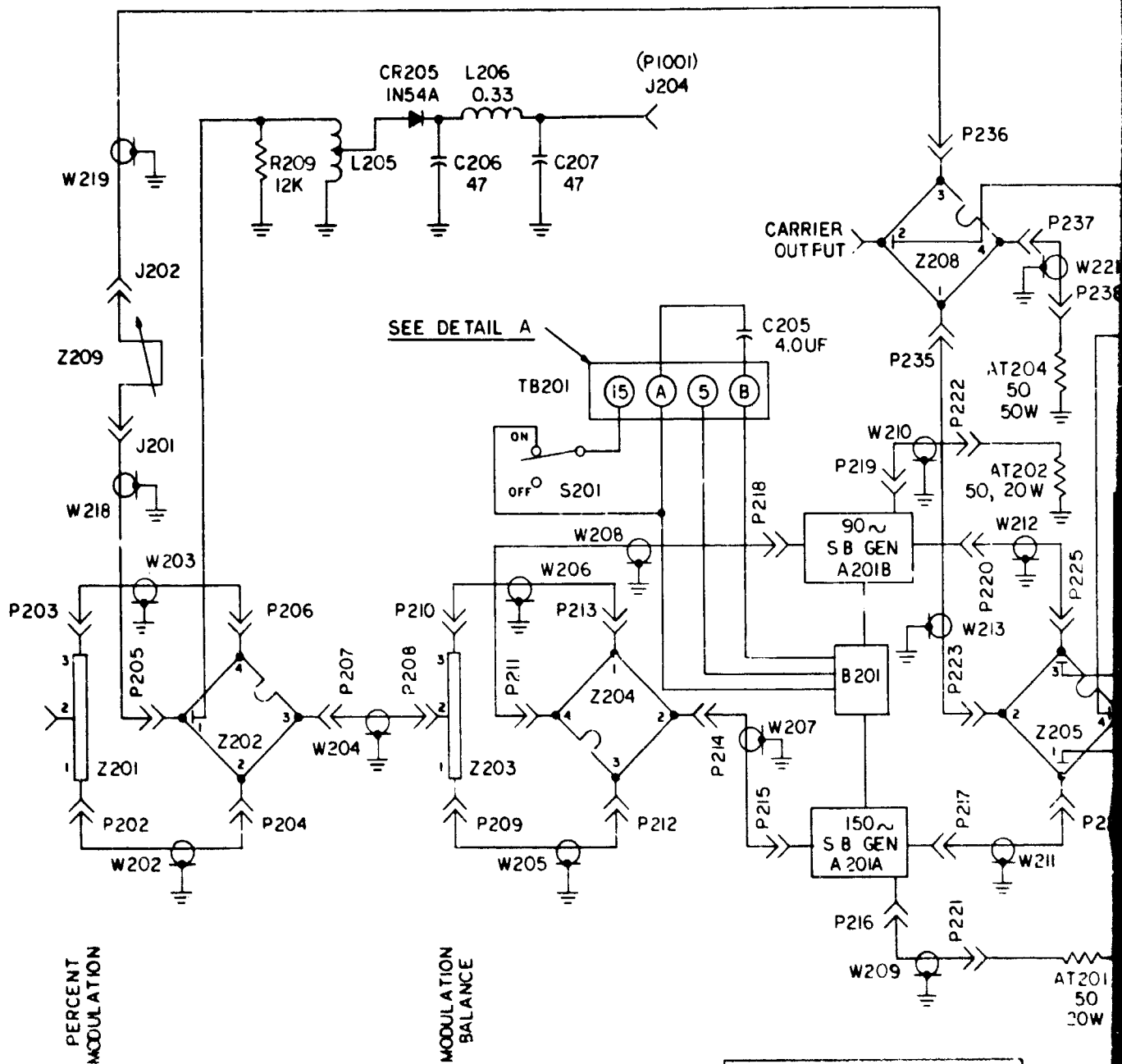

SEE DETAIL A

PERCENT MODULATION

MODULATION BALANCE

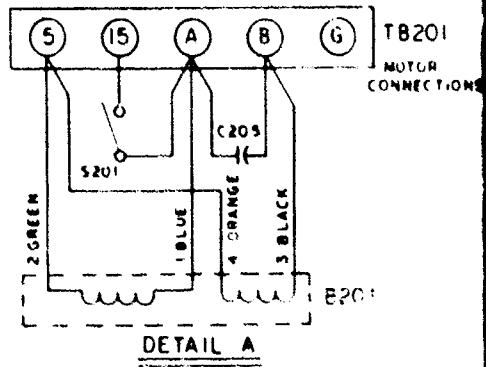

A

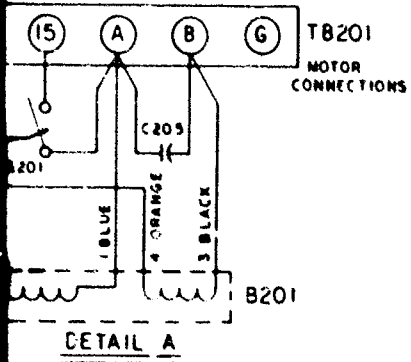
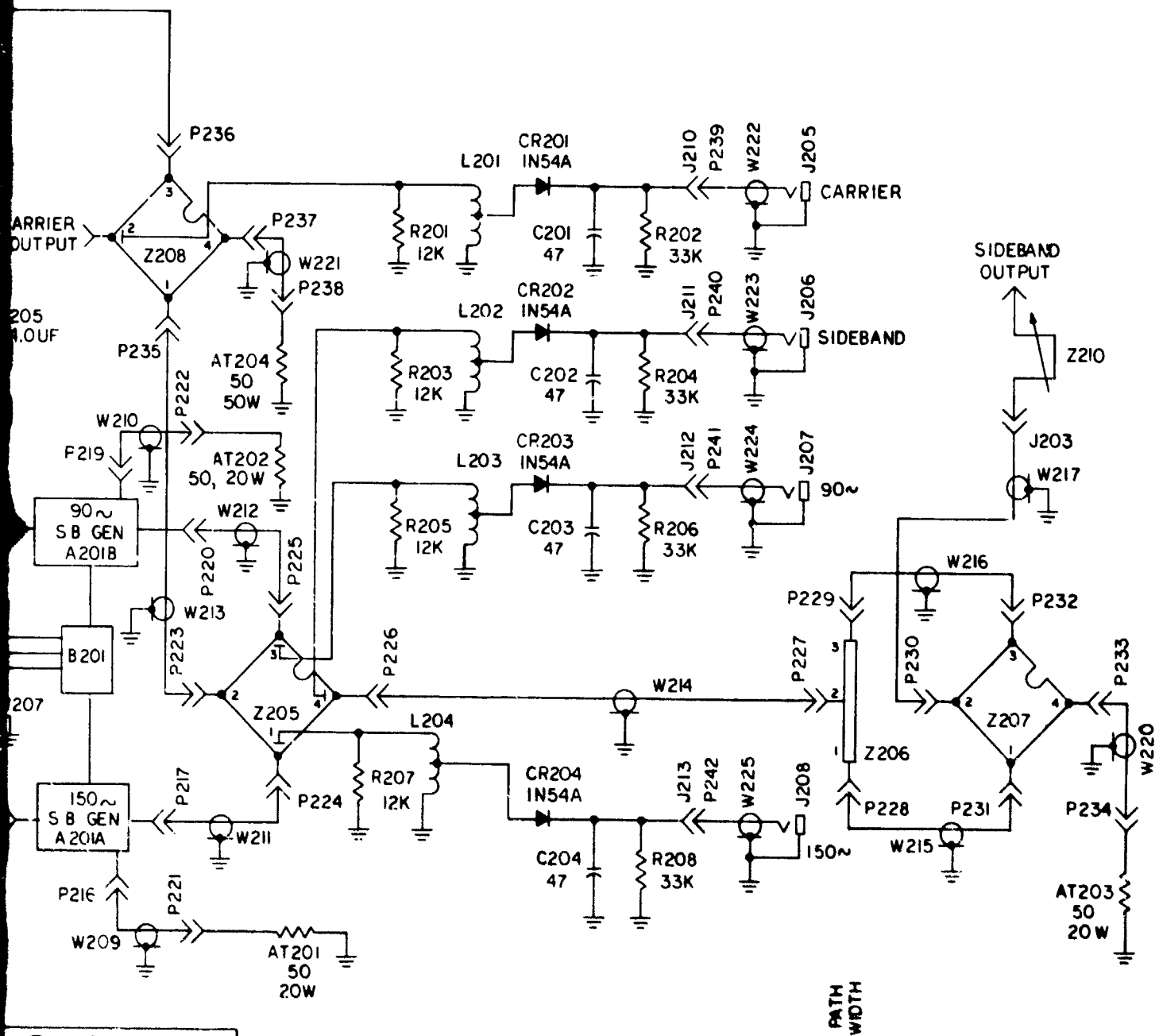

NOTES:

- 1. UNLESS OTHERWISE SPECIFIED:
 RESISTANCE VALUES ARE IN OHMS.
 CAPACITANCE VALUES ARE IN PICOFARADS.
 INDUCTANCE VALUES ARE IN MICROMHENRIES.

Figure A-66. Schematic Diagram,
 Modulation Control Unit Glide
 Slope Transmitter (E2205259)

B

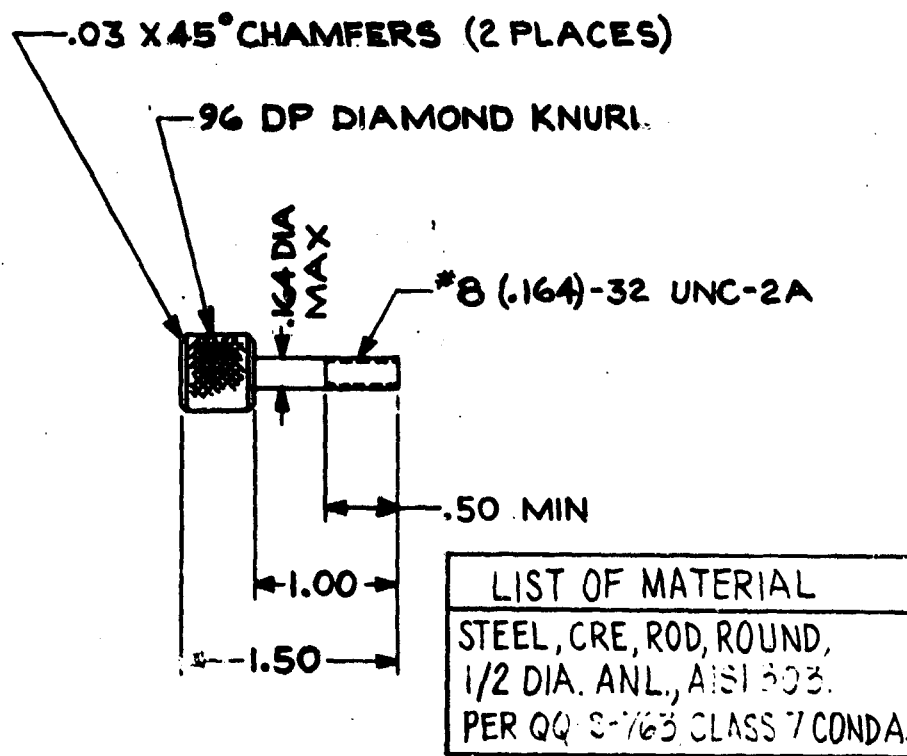
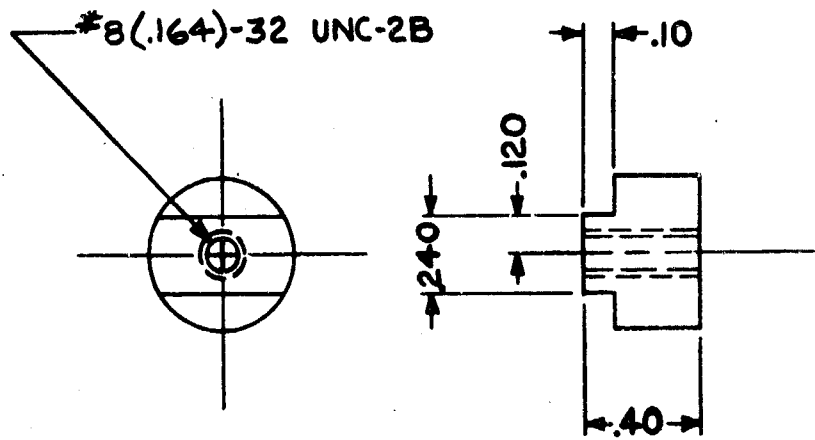
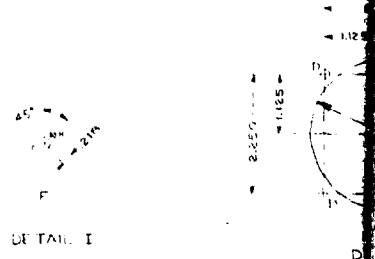
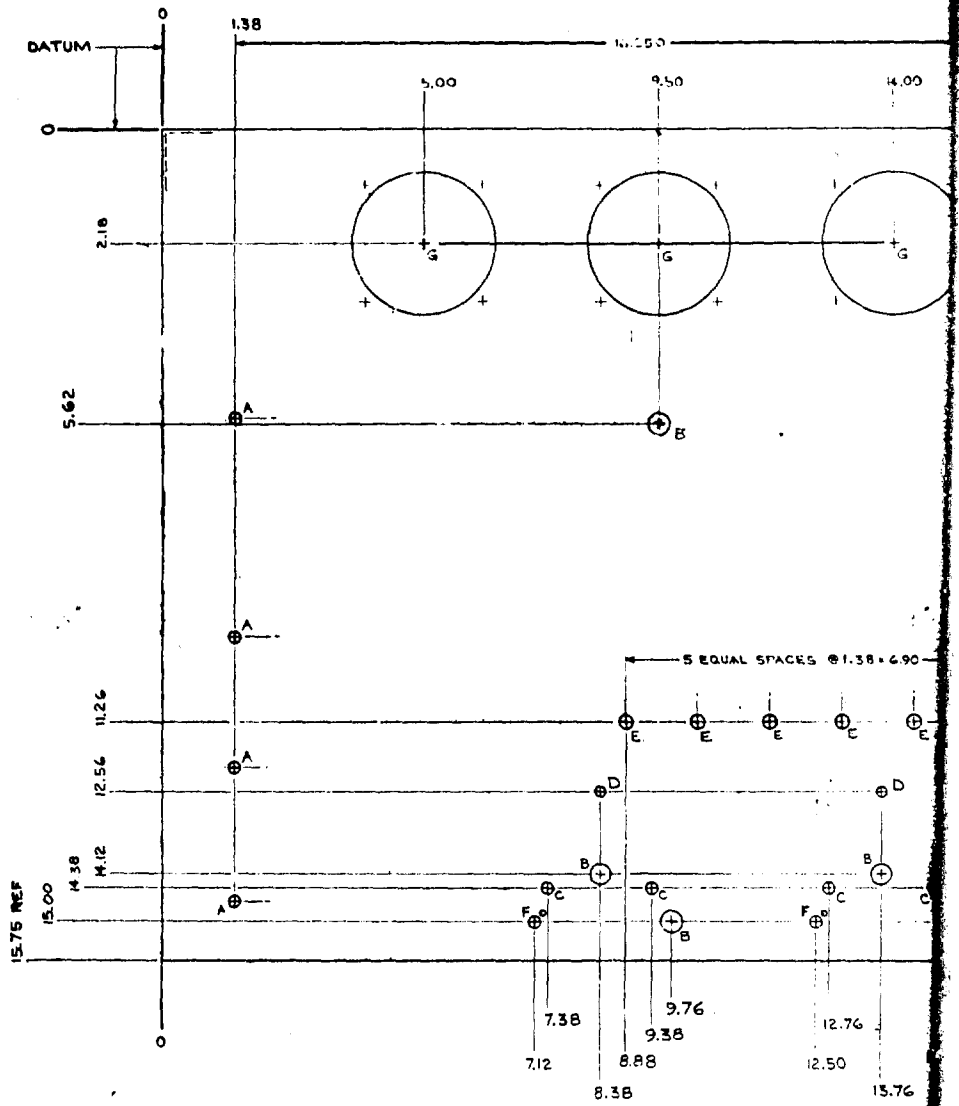

Figure A-87. Screw, Thumb (B2205261)



| |
|--|
| LIST OF MATERIAL |
| BRASS, ROD, ROUND, 1/2 DIA, HALF HARD, BEST COML QUALITY |

Figure A-68. Nut (B2205262)



DE TAIL I

A

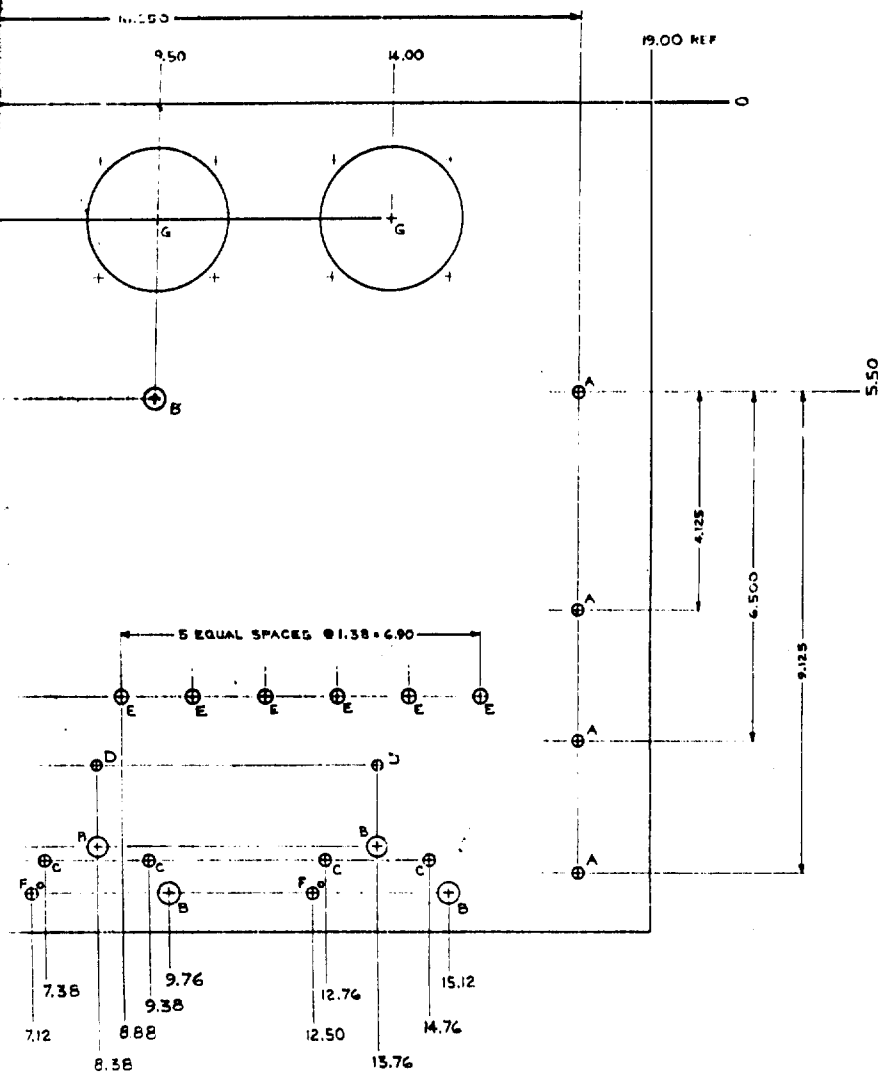

| HOLE | DESCRIPTION |
|------|---------------|
| A | .257-.247 DIA |
| B | .351-.391 DIA |
| C | .216-.223 DIA |
| D | .167-.177 DIA |
| E | .245-.255 DIA |
| F | SEE DETAIL I |
| G | SEE DETAIL II |
| H | .088-.089 DIA |

SEE MATERIAL
 PANEL ENCLOSURE
 PANEL # 1415

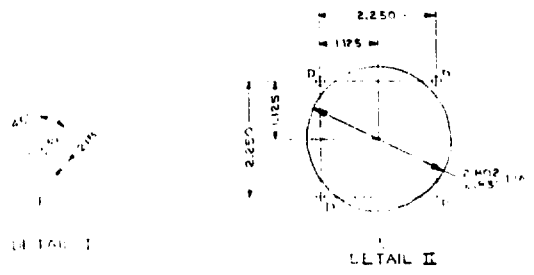
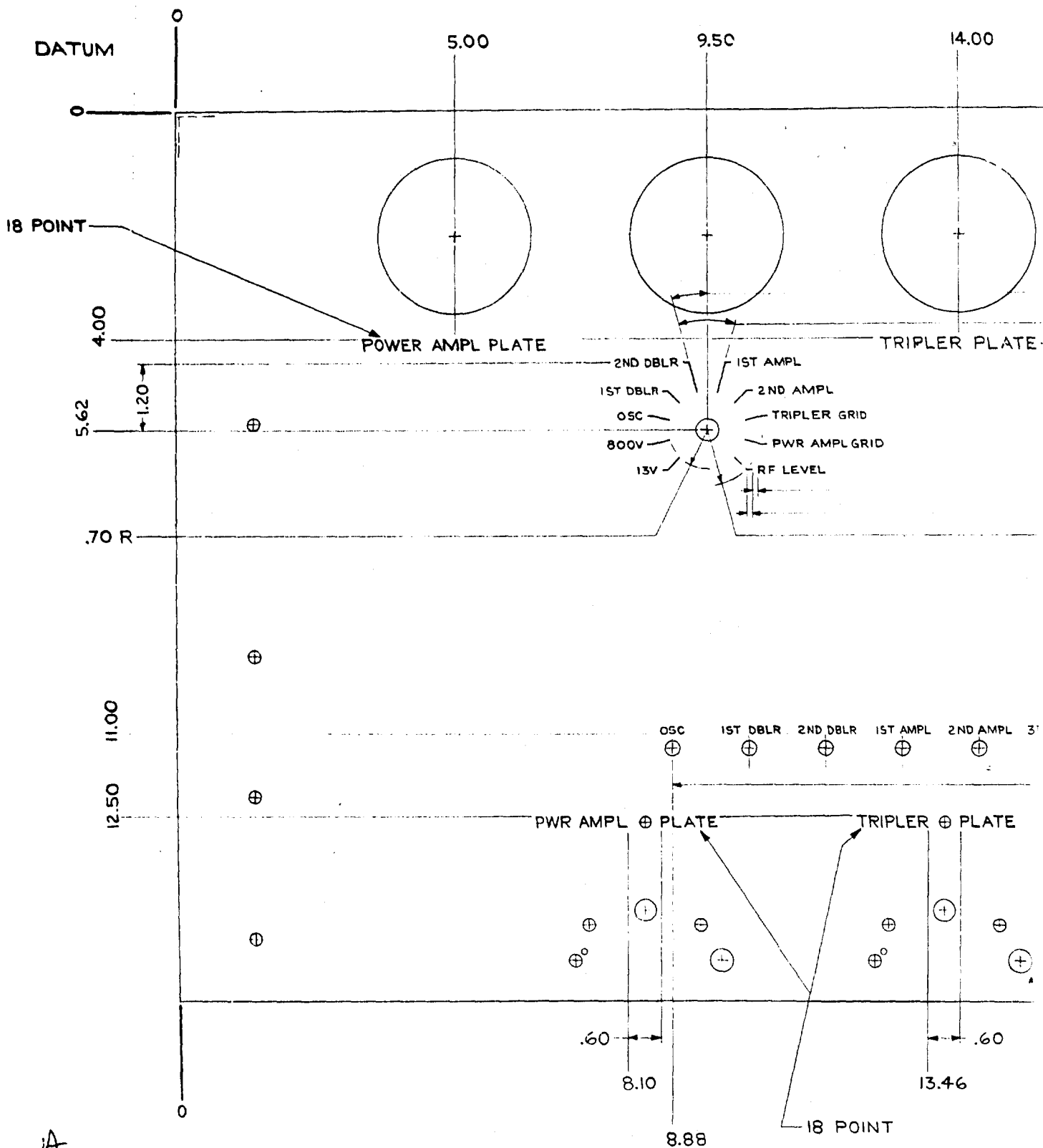

Figure A-69. Panel, Front (Drilling)
 (E2205263)

B



A

4.00

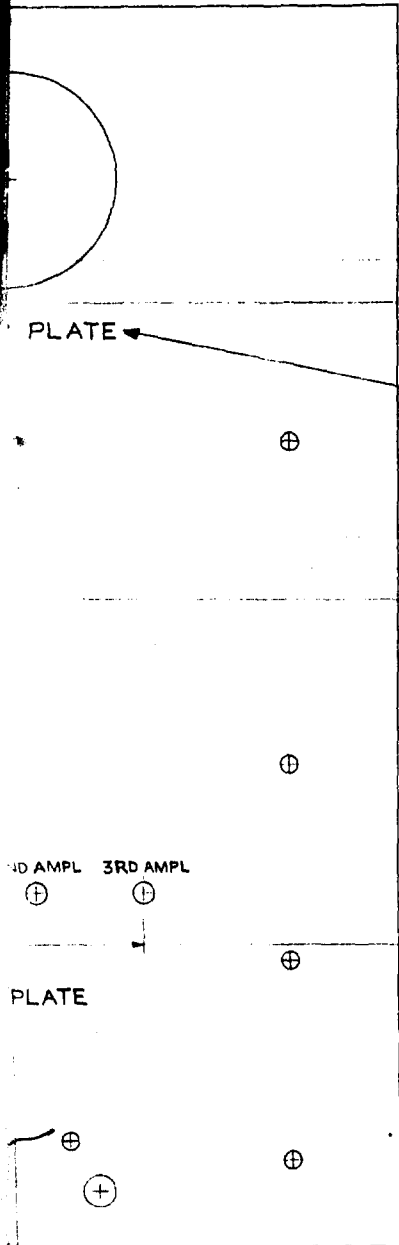

NOTES:

1. MARK PER A2205220 PARA "B" PAINT TO BE BLACK IN COLOR.
2. CHARACTERS TO BE 12 POINT UNLESS OTHERWISE SPECIFIED & CENTRALLY LOCATED AS SHOWN.
3. ALL LINES TO BE .03 THK.

5 EQUAL SPACES @ 1.38 = 6.90

| LIST OF MATERIAL | | | | | | |
|------------------|-----|-----------|---------|-----|-----------------------------|---------------------------|
| GROUP | QTY | U OF ITEM | PART OR | | NOMENCLATURE OR DESCRIPTION | |
| G3 | G2 | G1 | M | NO. | IDENTIFYING NO. | |
| | | X | 20 | 2 | 2205220 | SPECIFICATION FOR MARKING |
| | | 1 | 1 | 1 | 2205263 G1 | PANEL, FRONT (DRILLING) |

.60

Figure A-70. Panel, Front (Marking)
(E2205264)

B

A-71

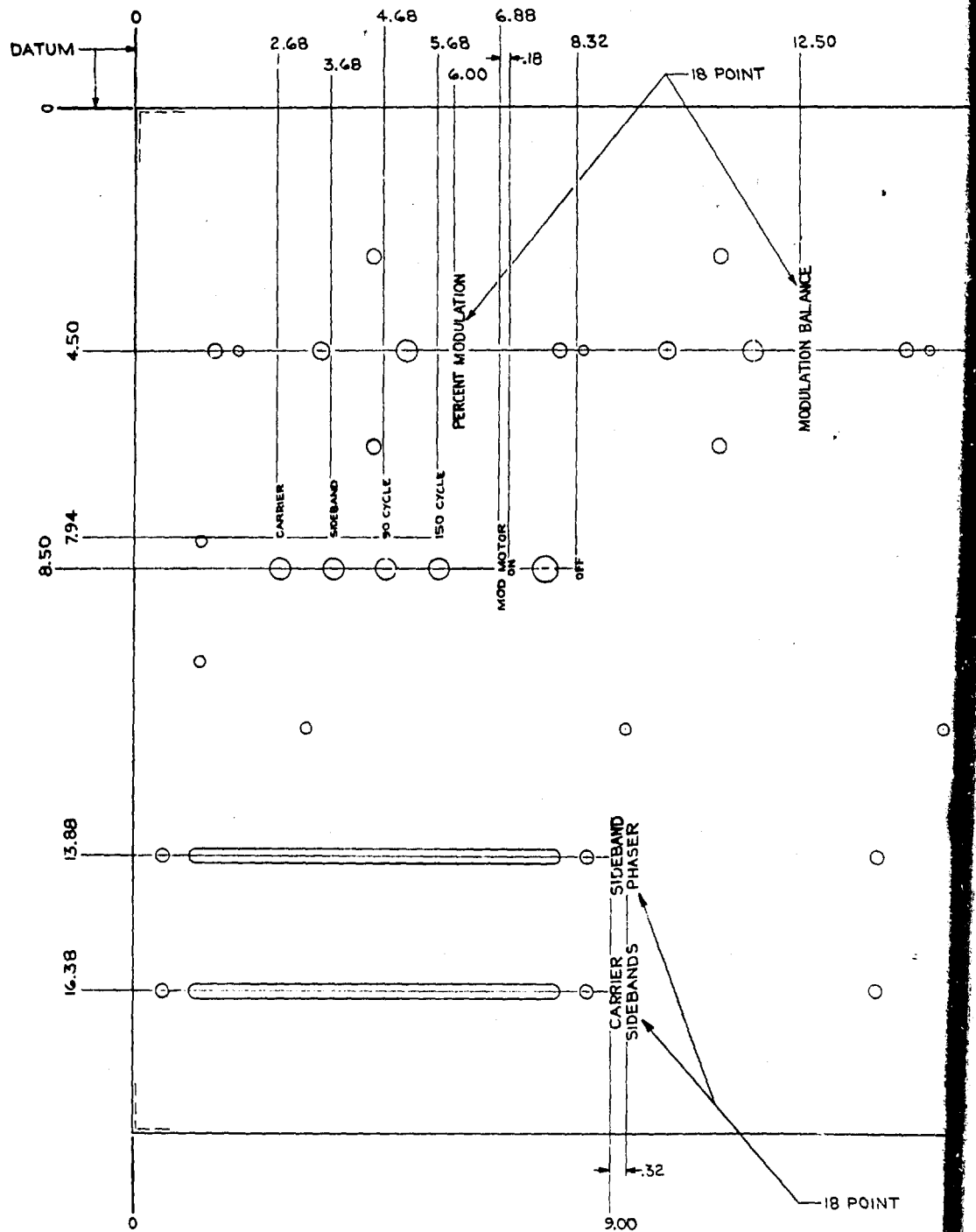

LIST OF MATERIAL

| GROUP | QTY | UOM | ITEM | PART OR IDENTIFYING NO. | NOMENCLATURE OR DESCRIPTION |
|-------|-----|-----|------|-------------------------|-----------------------------|
| G3 | G1 | M | NO | 2205220 | SPECIFICATION FOR MARKING |
| | | | | 2205217 G1 | PANEL FRONT (DRILLING) |

NOTES:
 1. MA
 PA
 2. CH
 UN
 CE

A

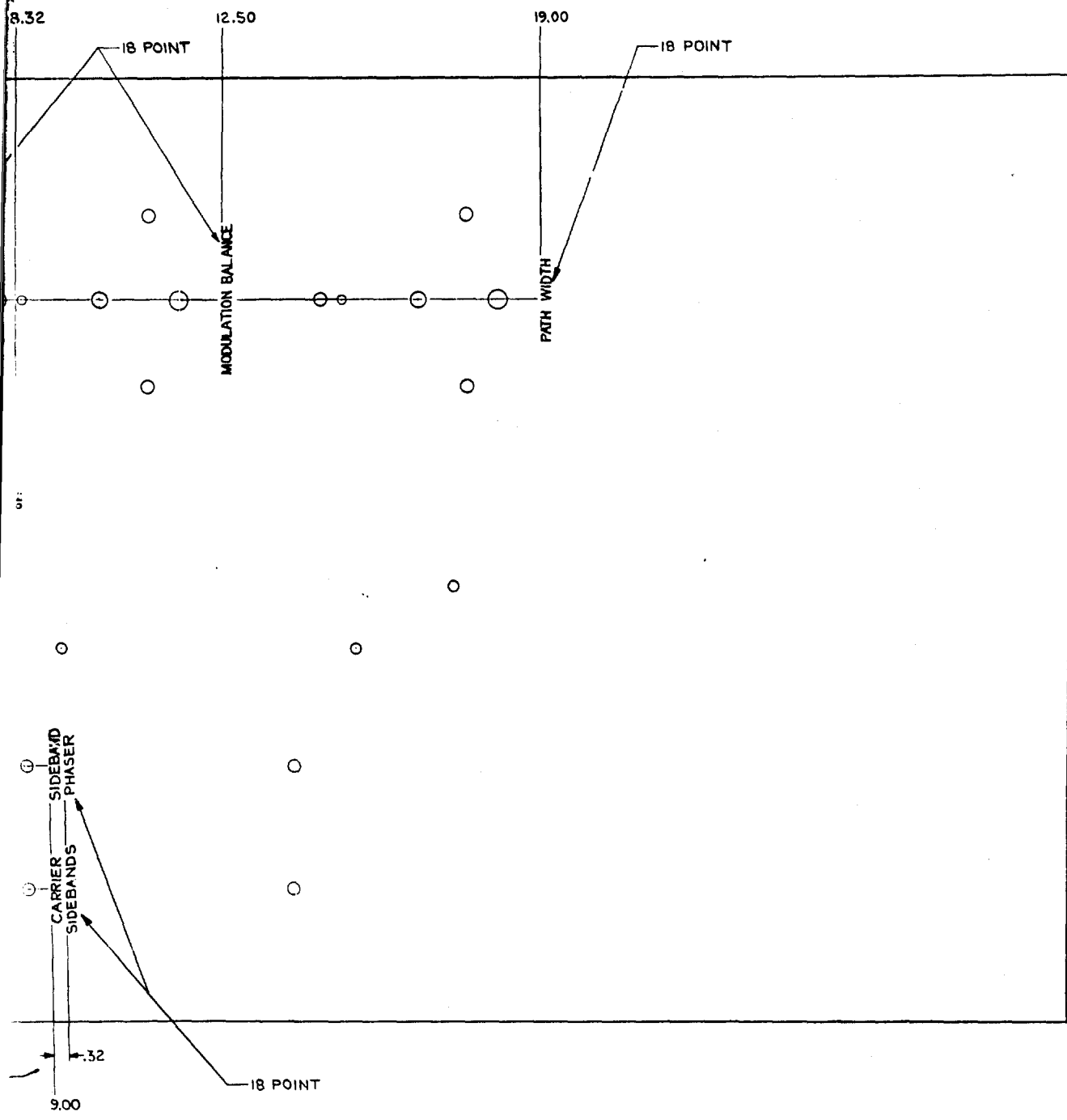

NOTES:

1. MARK PER A2205220 PARA "B", PAINT TO BE BLACK IN COLOR.
2. CHARACTERS TO BE 12 POINT UNLESS OTHERWISE SPECIFIED, & CENTRALLY LOCATED AS SHOWN.

Figure A-71. Panel, Front (Marking)
(E2205265)

A-72

B

| | |
|-----------------------|--|
| AL | |
| FIGURE OR DESCRIPTION | |
| FOR MARKING | |
| (DRILLING) | |

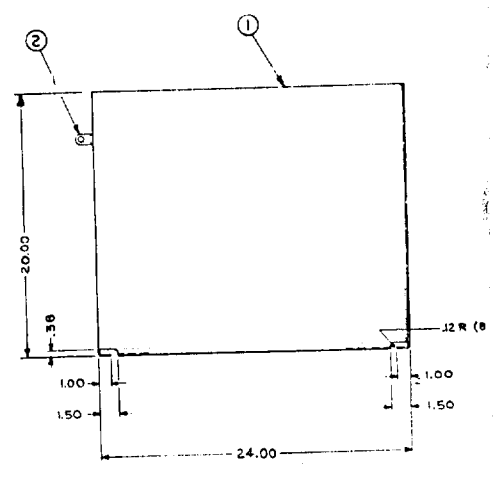
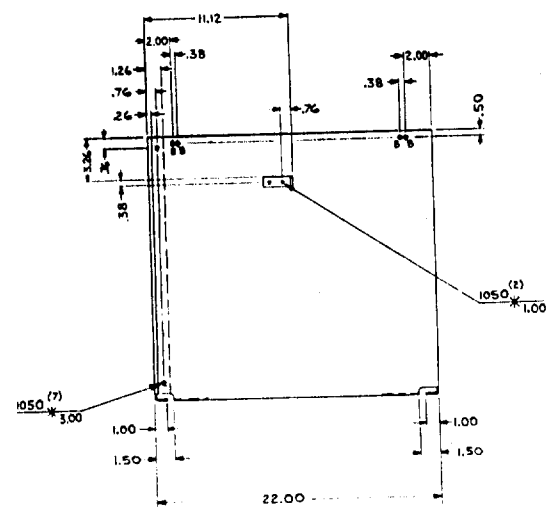
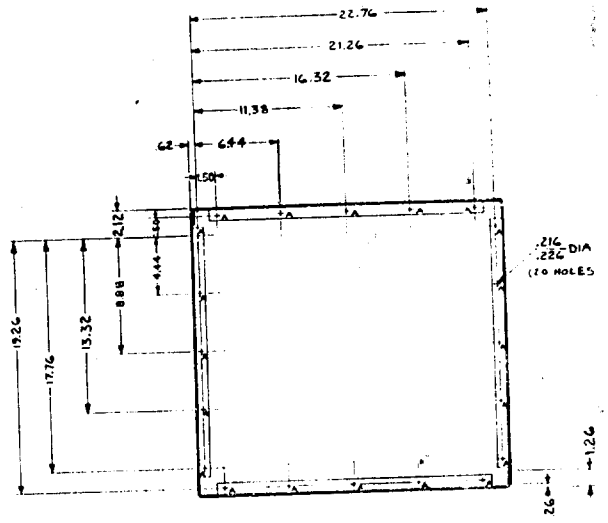

NOTES:
 1. ALL BEND RADI TO
 2. PAINT ITEM 2 # FC
 SURFACES OF ITEM
 ITEM 3. (A2134132C

A

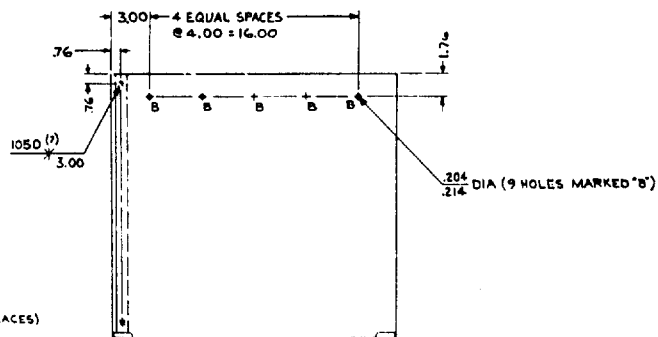
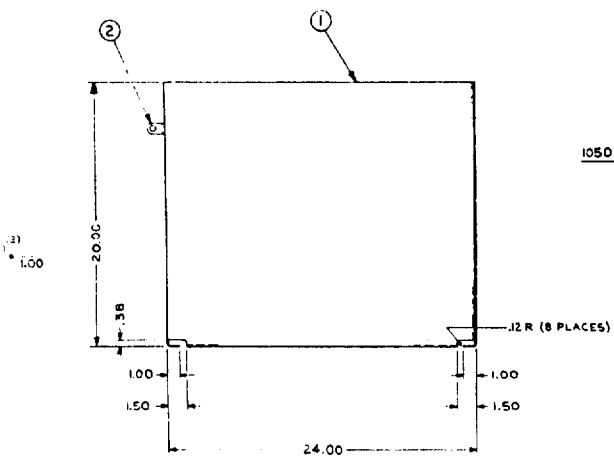
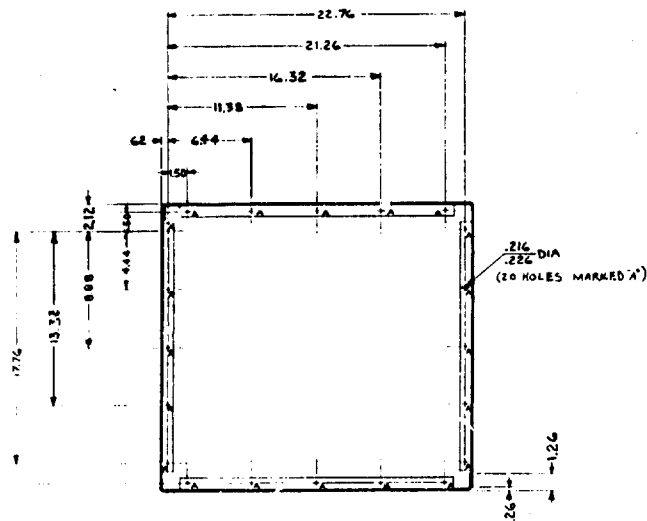

| LIST OF MATERIAL | | | | |
|------------------|-----|------|-----------|---|
| GROUP | QTY | U OF | PART OR | NOMENCLATURE OR DESCRIPTION |
| 65 | 62 | GT | M NO | IDENTIFYING NO. |
| | 1 | 1 | 2134132G2 | FINISH, WHITE ENAMEL |
| | 1 | 1 | 2205267G1 | BRACKET, LOCK |
| | 2 | 1 | 1 | ALUM. ALLOY SHEET .125 THK, TYPE 7022-MSZ |
| | | | | |
| | | | | |
| | | | | |

NOTES:
 1. ALL BEND RADI TO BE .12
 2. PAINT ITEM 2 & FOUR OUTSIDE SURFACES OF ITEM 1 PER ITEM 3.(A2134132G2).

Figure A-72. Box, Battery (E2205266)

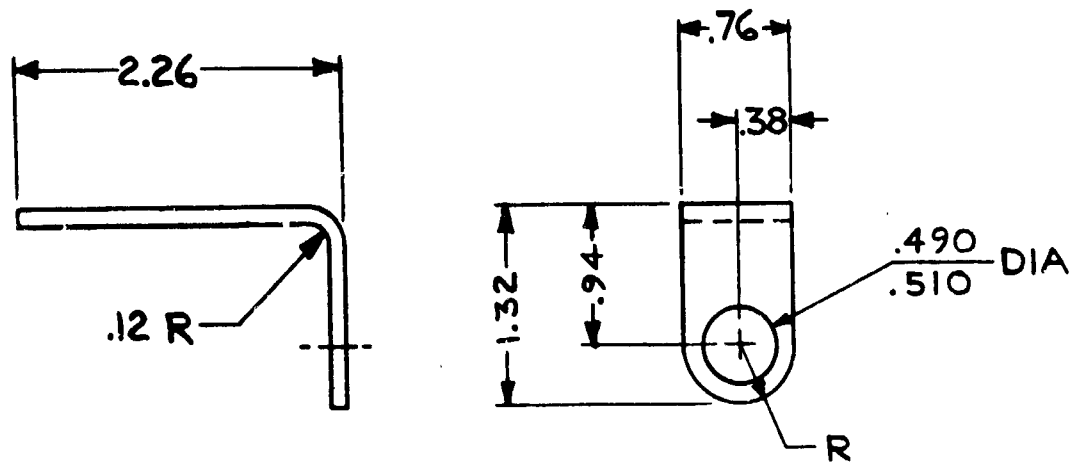

| |
|------------------|
| LIST OF MATERIAL |
| ALUMINUM, ALLOY, |
| SHEET, .125 THK, |
| TYPE 5052-H32 |

Figure A-73. Bracket, Lock (B2205267)

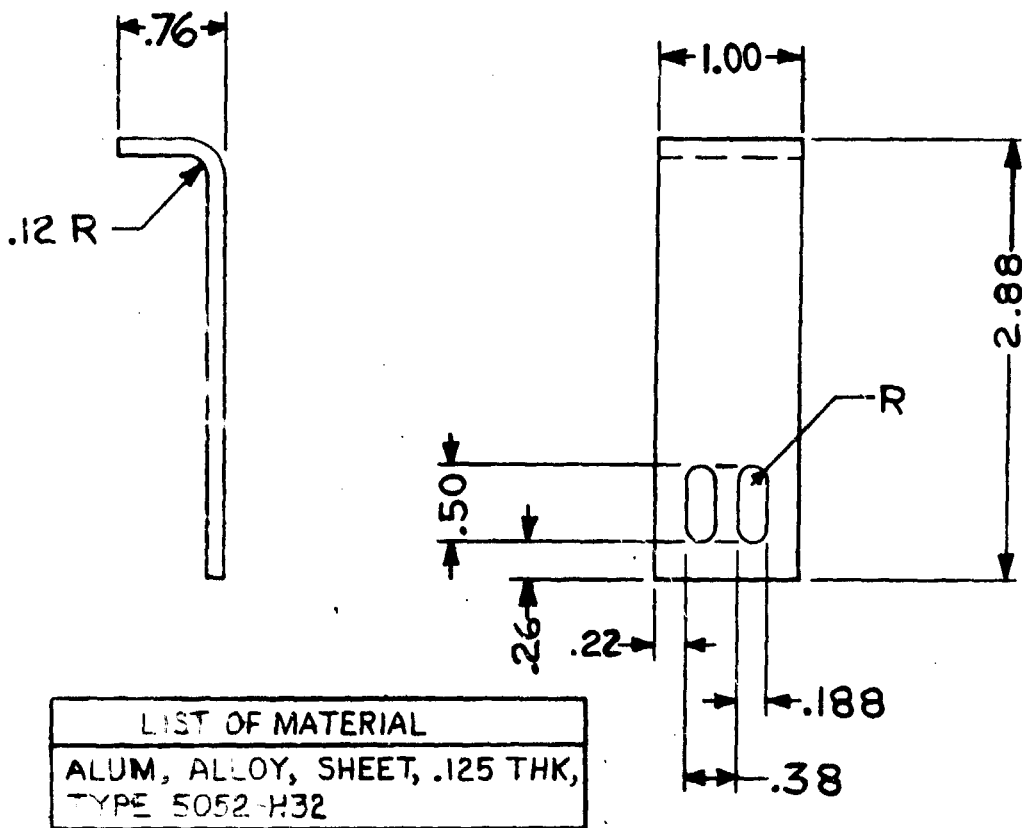

Figure A-74. Bracket (B2205268)

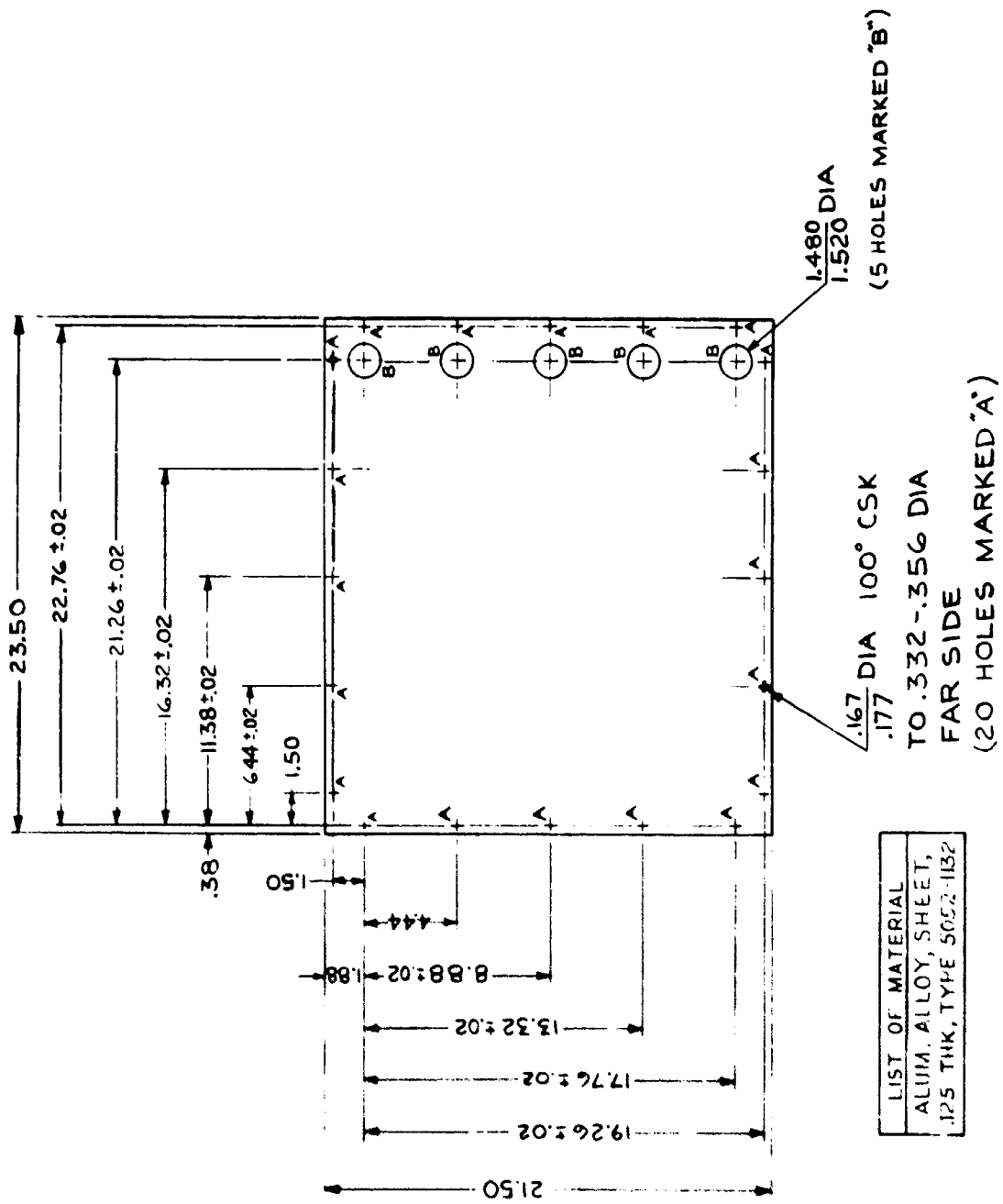
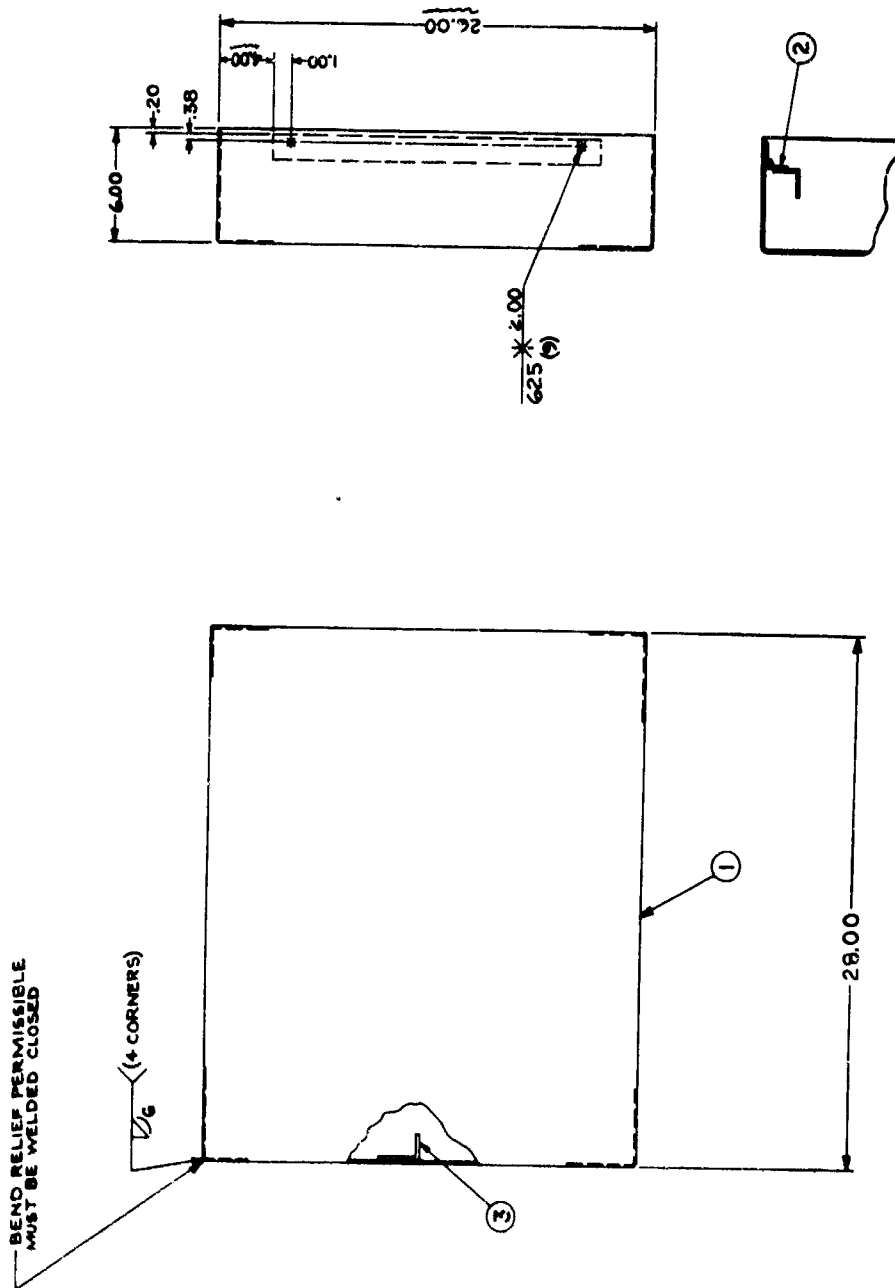

Figure A-75. Plate (C2205269)



| GROUP QTY | | INQ/ITEM | | LIST OF MATERIAL | |
|-----------|----|----------|----|-------------------------|--|
| G3 | G2 | M | NO | PART OR IDENTIFYING NO. | NOMENCLATURE OR DESCRIPTION |
| | 4 | | 4 | 2134132G2 | FINISH WHITE ENAMEL |
| | 1 | | 3 | 2205271G1 | BRACKET, LOCK |
| | 1 | | 2 | 2205271G1 | HINGE |
| | 1 | | 1 | | ALUM. ALLOY SHEET, .125 THK, TYPE 3003-H14 |

- NOTES:
1. ALL BEND RADII TO BE .12
 2. PAINT TOP / FOUR OUTSIDE SURFACES OF ITEM 1 PER ITEM 4, (A2134132G2).

Figure A-76. Cover, Battery Box (D2205270)

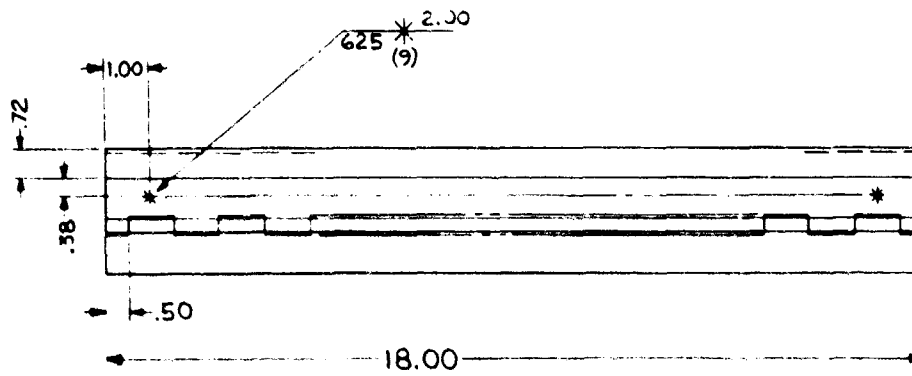
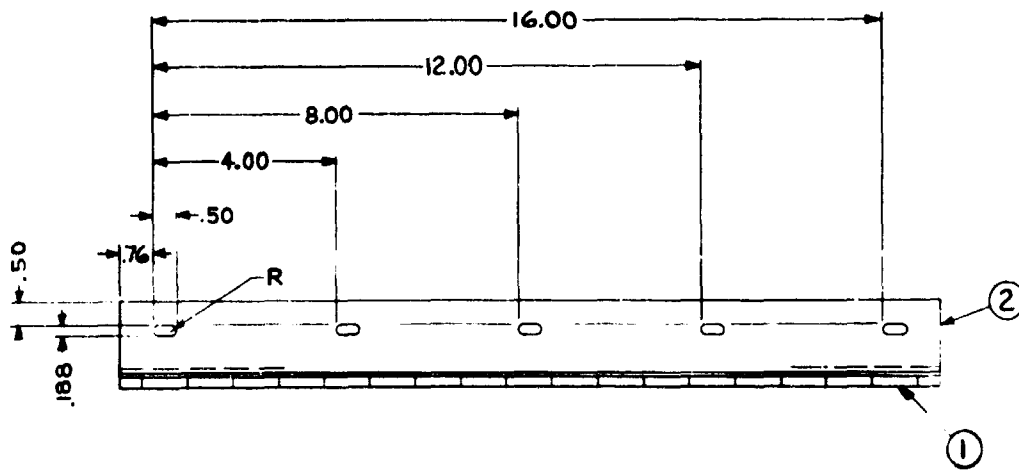

| LIST OF MATERIAL | | | | | |
|------------------|-----|-----|------|------------------------|---------------------------------------|
| GROUP | QTY | UOM | ITEM | PART OR IDENTIFYING NO | NOMENCLATURE OR DESCRIPTION |
| G3 | 32 | 31 | M | 2 | ALUM. ALLOY SHAPE EXTR. ANGLE 50 ROOT |
| | | | | | 1/2 X 1 1/2 X 1/8 THK, TYPE 6063-T5 |
| | | | | | HINGE EXTR ALUM. 1.00 DIA CRES PIN. |
| | | | | | HOWER D BRONSON CO, BEACON FALLS CONN |
| | | | | | PART * EX 4 |

Figure A-77. Hinge (C2205271)

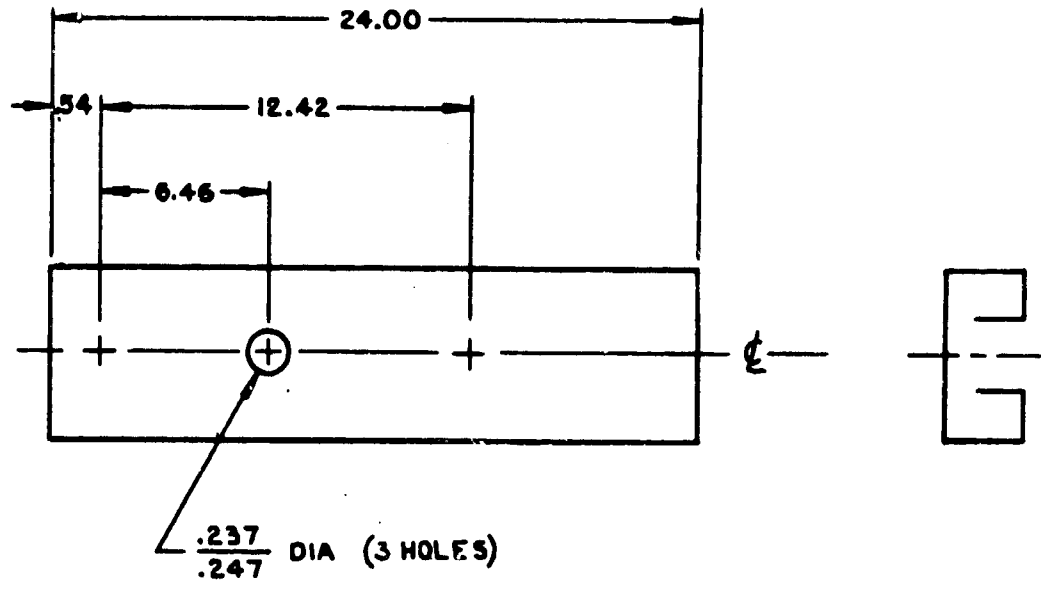

| |
|------------------|
| LIST OF MATERIAL |
| UNISTRUT #P-4000 |
| ALUMINUM |

Figure A-78. Channel (B2205272)

| | |
|-----------|---------------|
| 2205273G1 | AS SHOWN |
| 2205273G2 | OPPOSITE HAND |

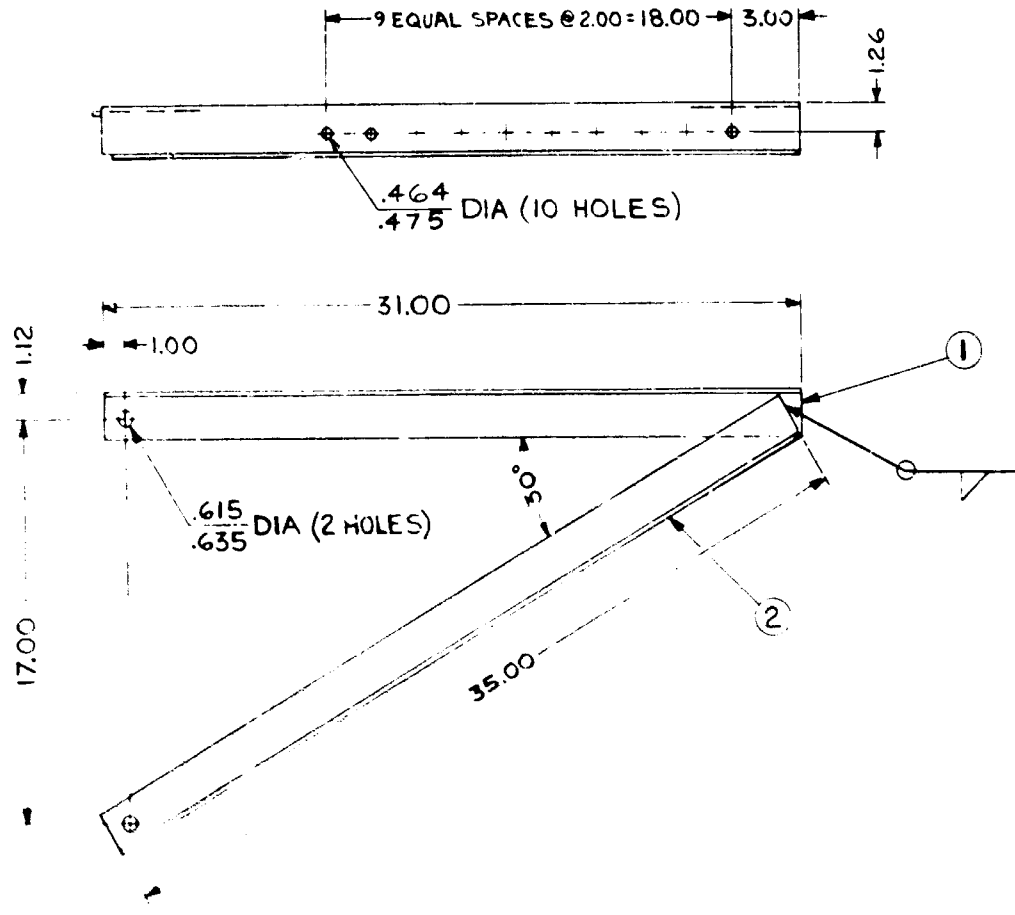

| LIST OF MATERIAL | | | | |
|------------------|-----|------|------------------------|-----------------------------|
| QTY | UOM | ITEM | PART OR IDENTIFYING NO | NOMENCLATURE OR DESCRIPTION |
| 1 | 1 | | | ANJL ALLOY SHAPE EXTR ANGLE |
| | | | | 50 ROOT, 2x2x3/16 THK, TYPE |
| | | | | 6063-T5 |

Figure A-79. Support, Angle (C2205273)

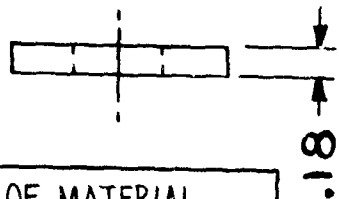
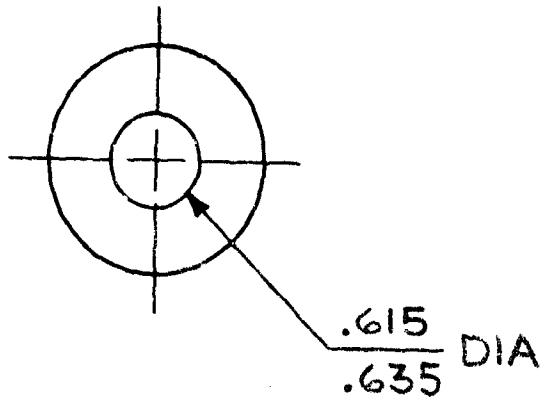

| |
|--|
| LIST OF MATERIAL |
| ALUM, ALLOY, ROD, 1 1/2 DIA, TYPE 6061-T6 |

Figure A-80. Spacer (B2205274)

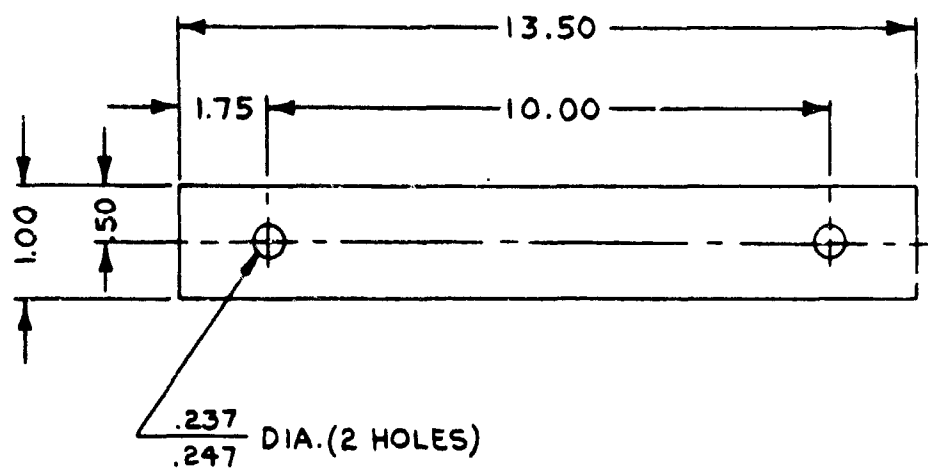

| LIST OF MATERIALS |
|--|
| ALUMINUM, ALLOY, SHEET .090 THK, TYPE 5052-H32 |
| FINISH: ALKALINE DIP (ROUGH ETCHED FROSTY-WHITE FINISH) THEN APPLY PROTECTIVE COATING (IRILAC #1000 ALLIED RESEARCH PROP, INC.) |

Figure A-81. Strap (A2205275)

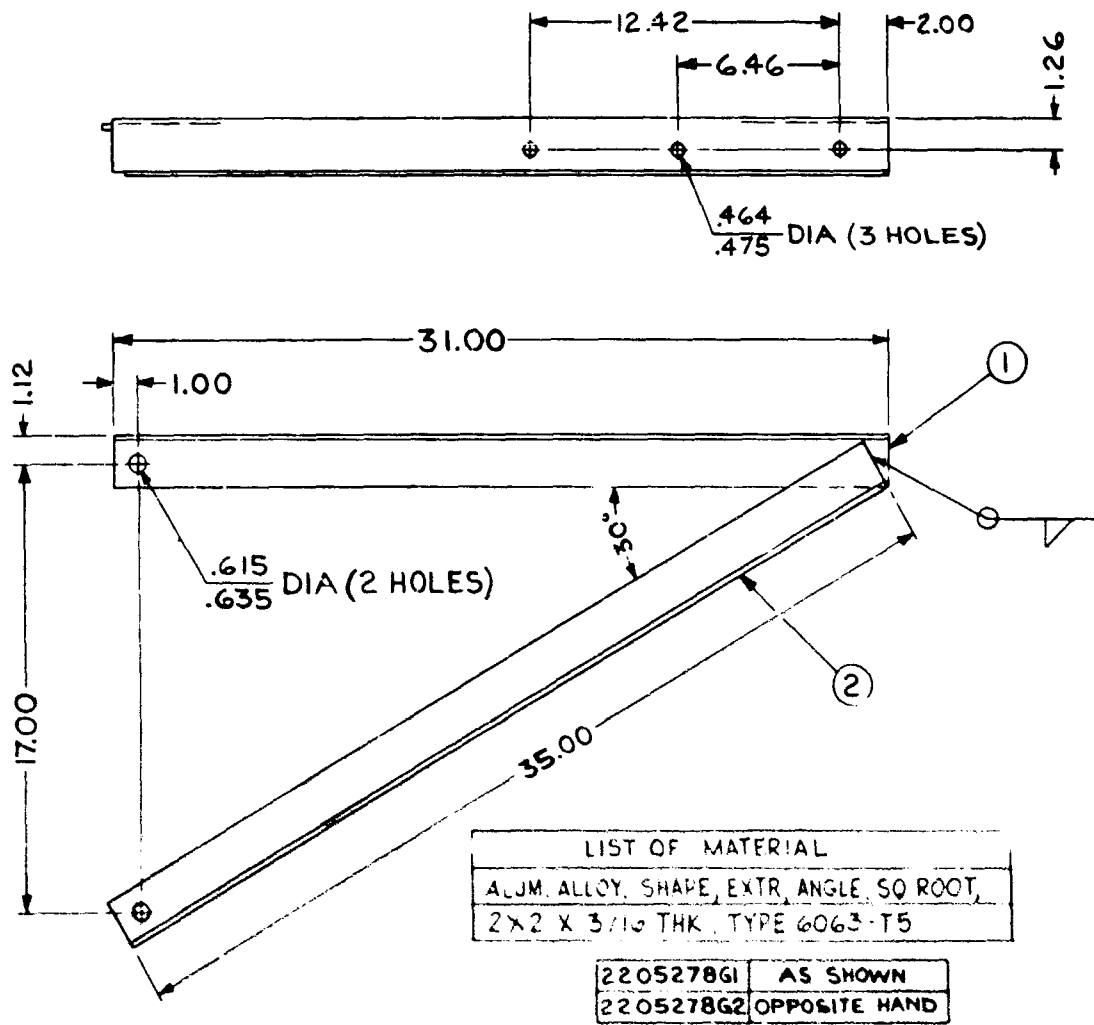
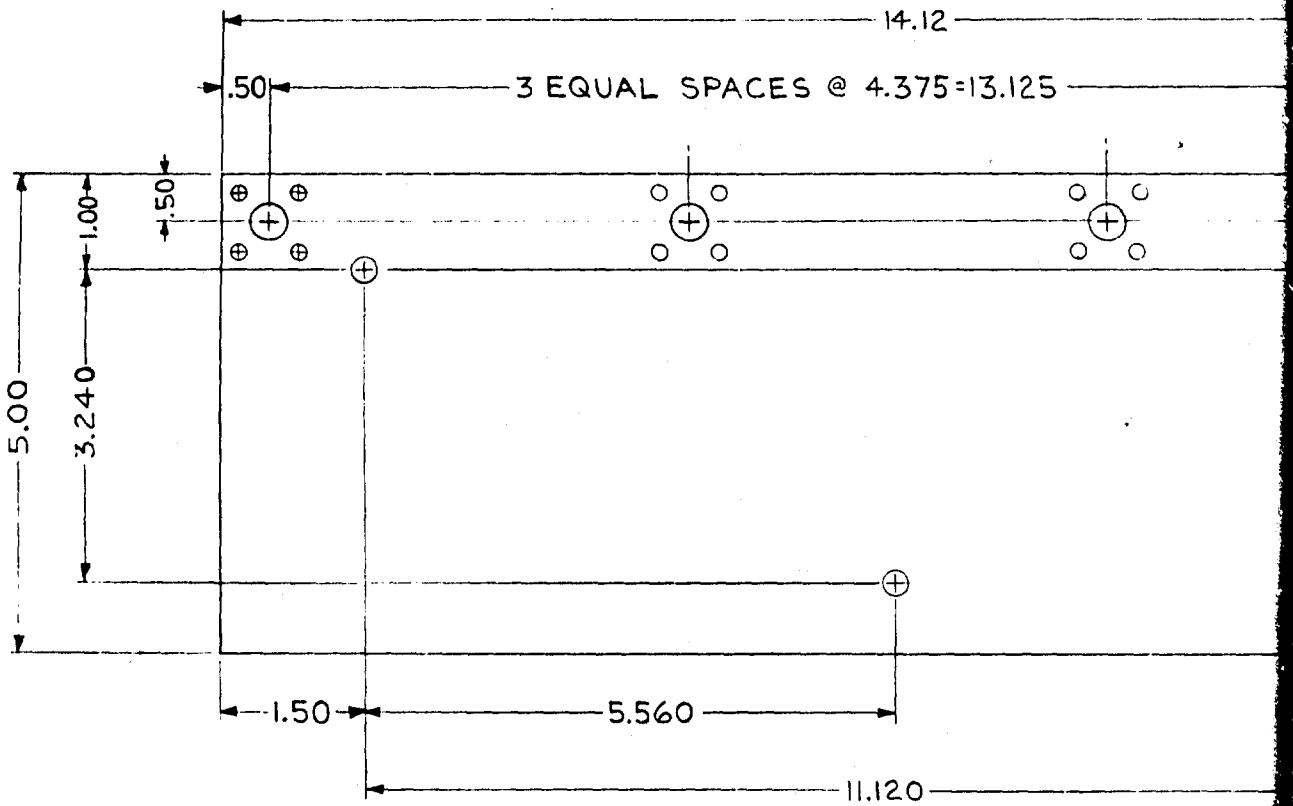
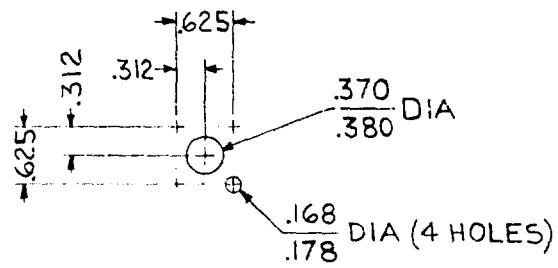

Figure A-82. Support, Angle (C2205278)



| |
|------------------|
| LIST OF MATERIAL |
| ALUMINUM, ALL |
| SHEET, .090 THK |
| TYPE 5052-H3 |



DETAIL I

A

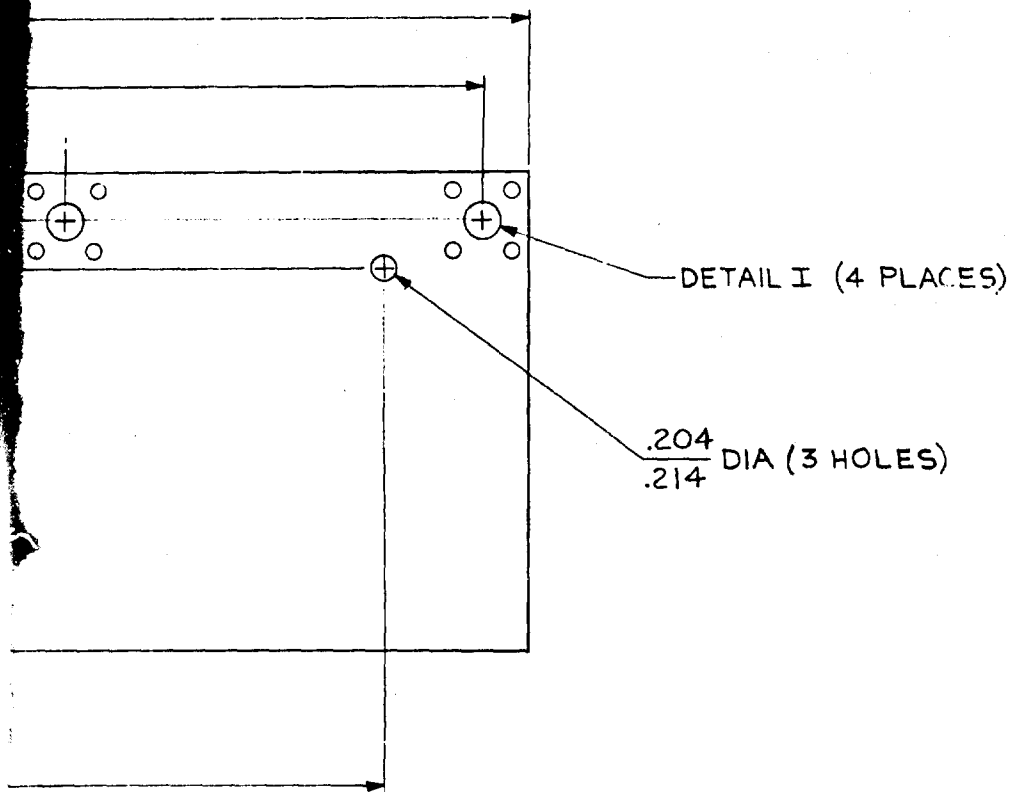

| |
|---|
| LIST OF MATERIAL ALUMINUM, ALLOY, SHEET, .090 THK, TYPE 5052-H34 |
|---|

FINISH:

ALKALINE DIP (ROUGH ETCHED FROSTY-WHITE
 FINISH) THEN APPLY PROTECTIVE COATING
 (IRILAC #1000 ALLIED RESEARCH PROP, INC.)

Figure A-83. Plate (D2205280)

A-84

B

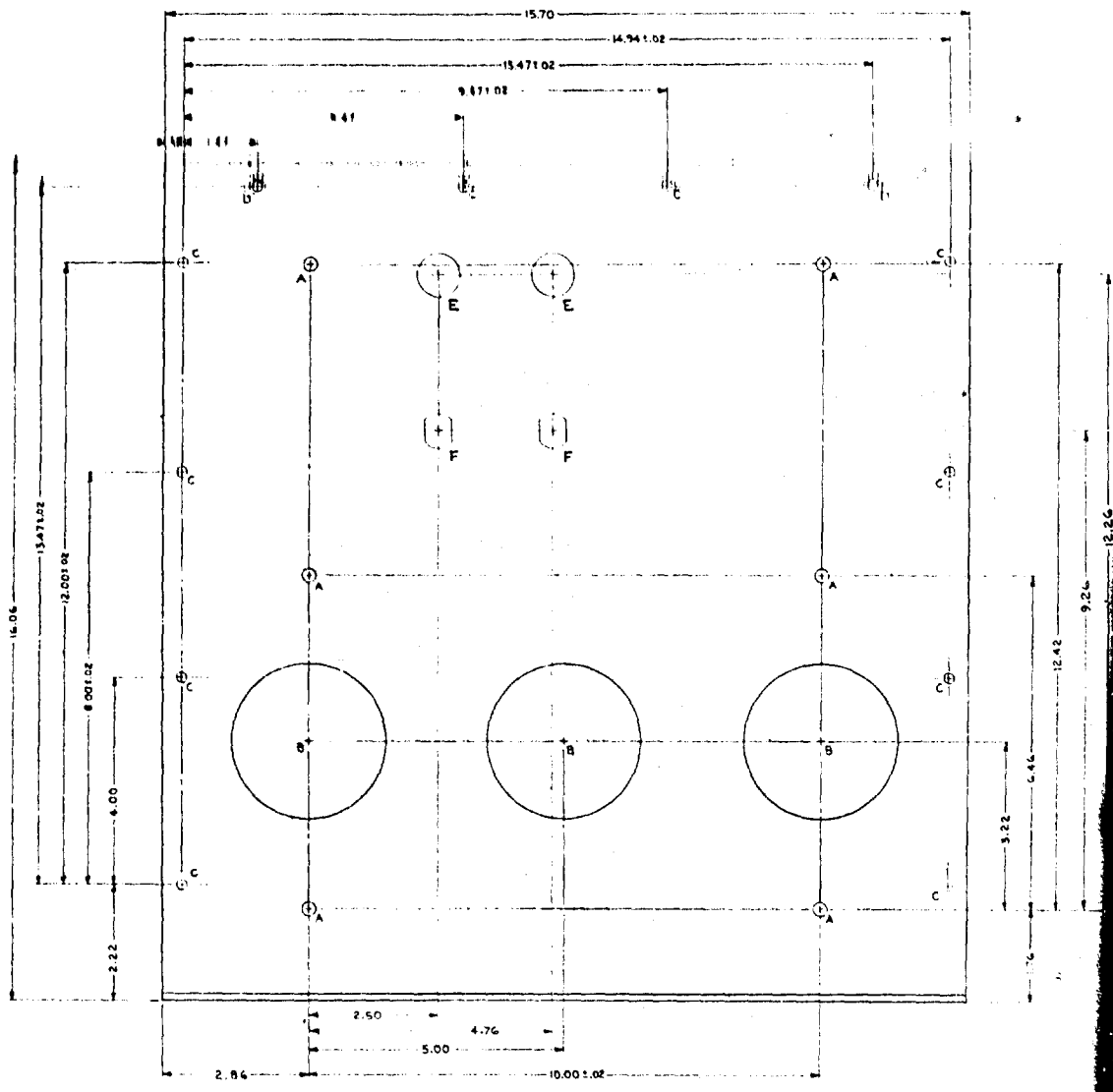

A

| HOLE | DESCRIPTION |
|------|---|
| A | .237-.247 DIA |
| B | 2.960-3.040 DIA |
| C | .204-.214 DIA |
| D | .627-.677 DIA 100° CLR TO .279-.301 DIA FAR SIDE |
| E | .402-.422 DIA |
| F | DF-0650 |
| G | .135-.145 DIA |

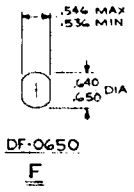
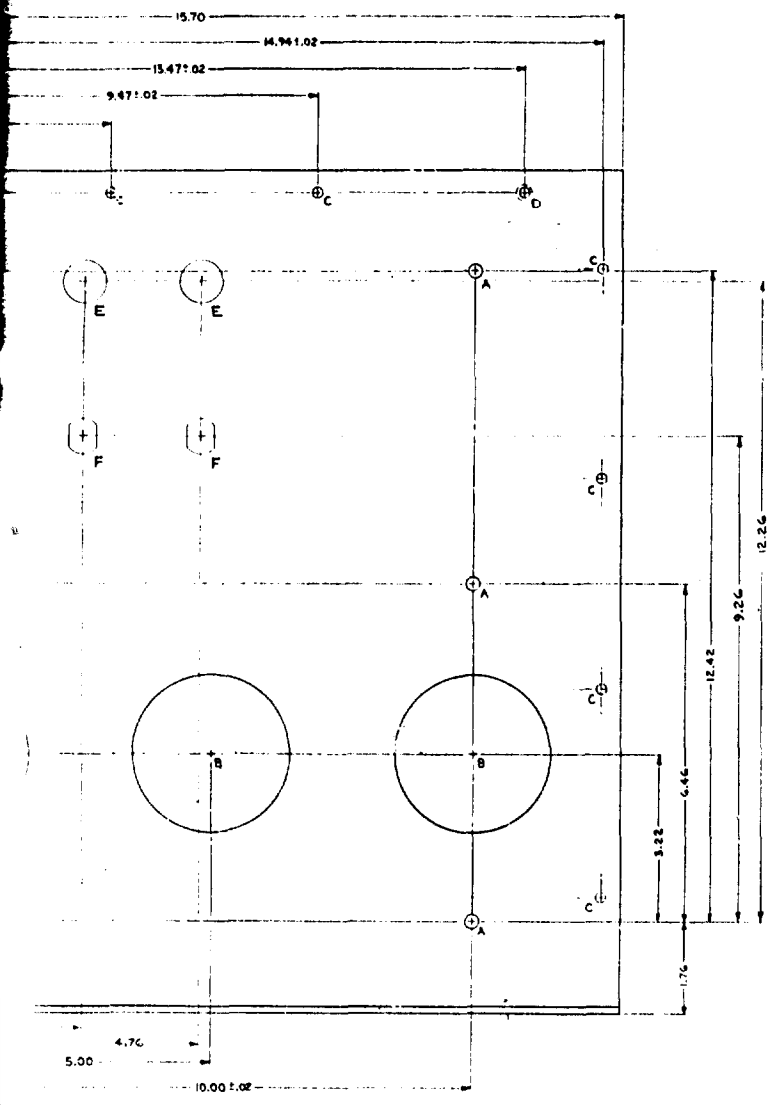

| LIST OF MATERIAL |
|-------------------------|
| ALUMINUM, ALLOY SHEET, |
| .125 THK, TYPE 5052-H32 |

FINISH:
ALKALINE DIP (ROUGH ETCHED FROSTY-
WHITE FINISH) THEN APPLY PROTECTIVE
COATING (IRILAC FROM A FIELD RESEARCH
PROP, INC.)

NOTE:
BEND RADIUS TO BE .12

Figure A-84. Plate, Bottom
(E2205284)

A-85

B

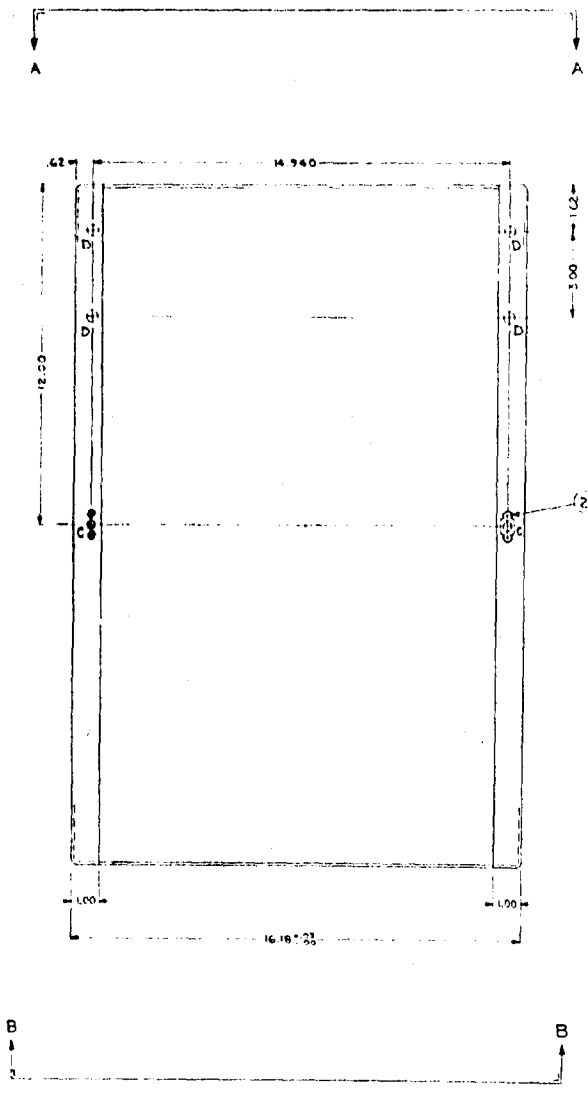
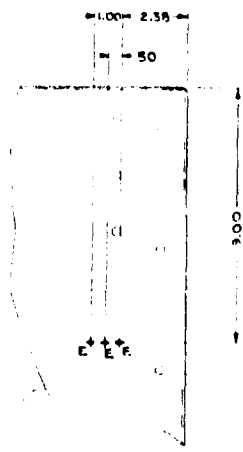

(2) (3) FORM OVER FAP SIDE

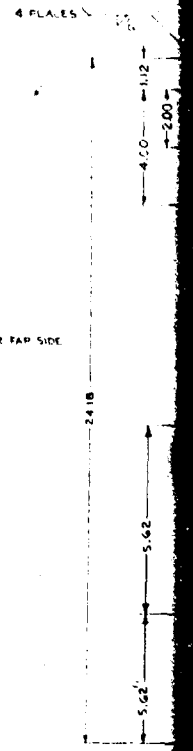

A

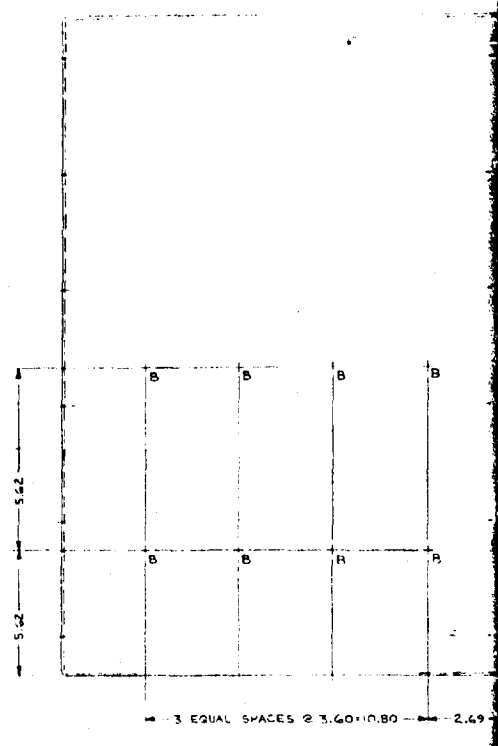
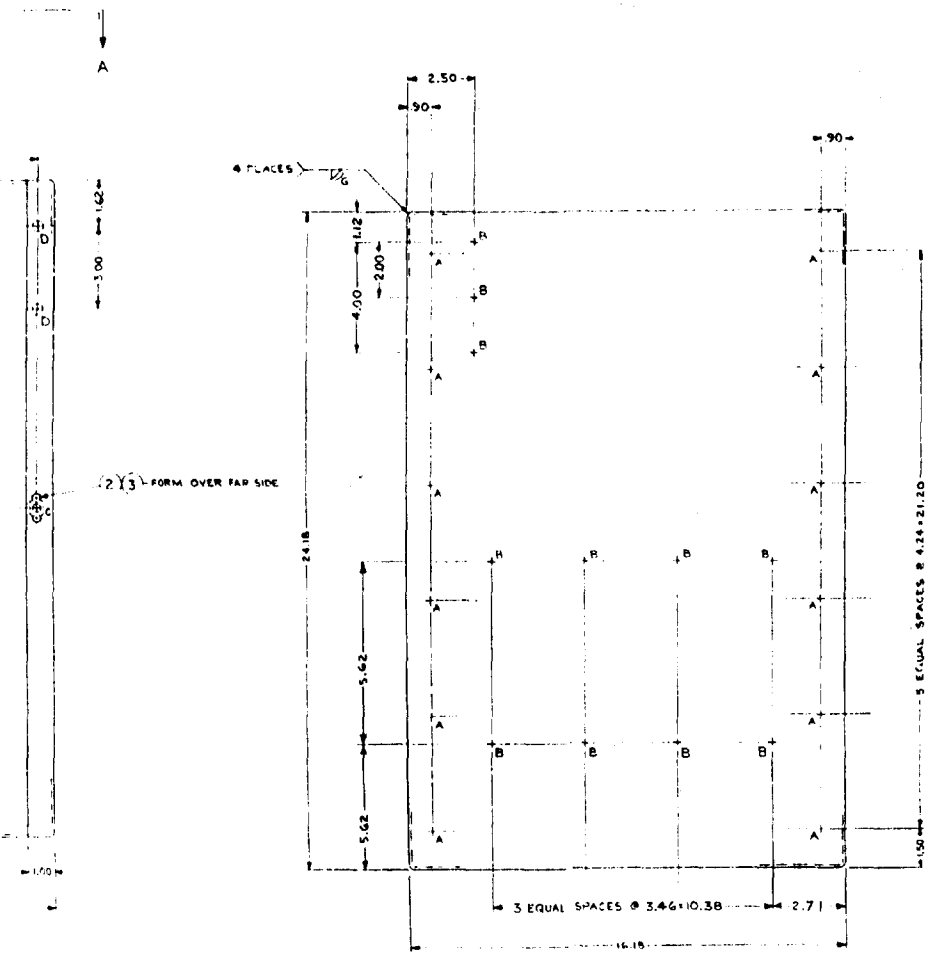

NOTE
ALL HOLES SHOWN IN THIS VIEW
ARE THRU BOTH SIDES

| LIST OF MATERIAL | | | |
|------------------|-------|-------------------------|-------------------------------------|
| QTY | UNIT | PART OR IDENTIFYING NO. | NOMENCLATURE OR DESCRIPTION |
| 1 | PLATE | 15495 | PLATE SOLID ALUM 100% SINK HO 11.21 |
| 1 | DRILL | 15495 | DRILLER MINATURE RECEPTACLE (GROSS) |
| 1 | DRILL | 15495 | DRILLER MINATURE RECEPTACLE (GROSS) |

B

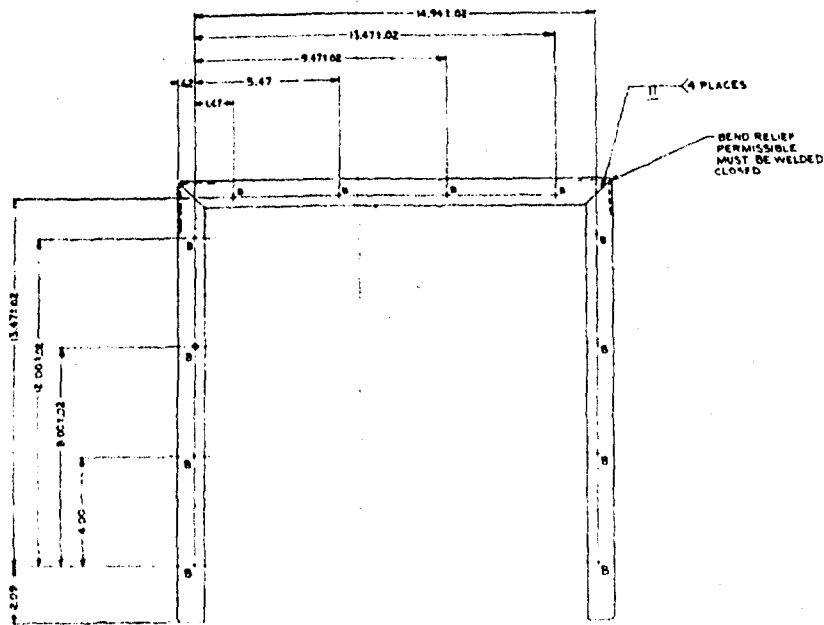

VIEW A-A

| HOLE | DESCRIPTION |
|------|-----------------|
| A | 257-.247 DIA. |
| B | 204-.214 DIA. |
| C | SEE DETAIL I |
| D | 370-.360 DIA. |
| E | 114-B-.178 DIA. |

NOTE
ALL BEND RADI TO BE .09

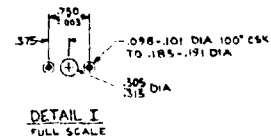
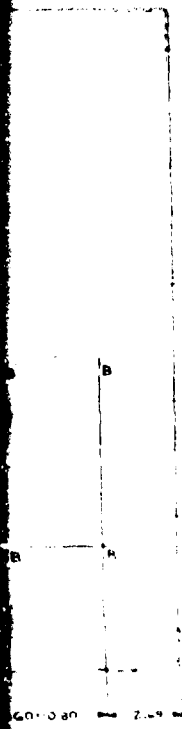

DETAIL I
FULL SCALE

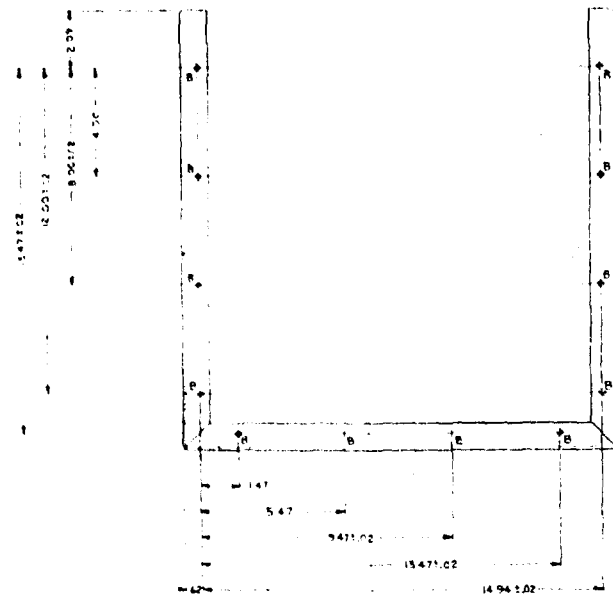

VIEW B-B

Figure A-85. Box, Inner (J2205286)

A-86

C

ALL DIMENSIONS ARE IN INCHES
UNLESS OTHERWISE SPECIFIED
TOLERANCES ARE AS SHOWN
UNLESS OTHERWISE SPECIFIED

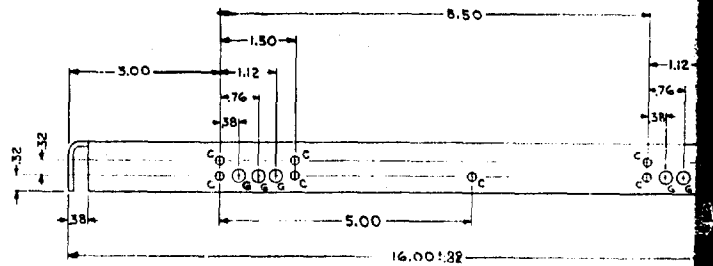
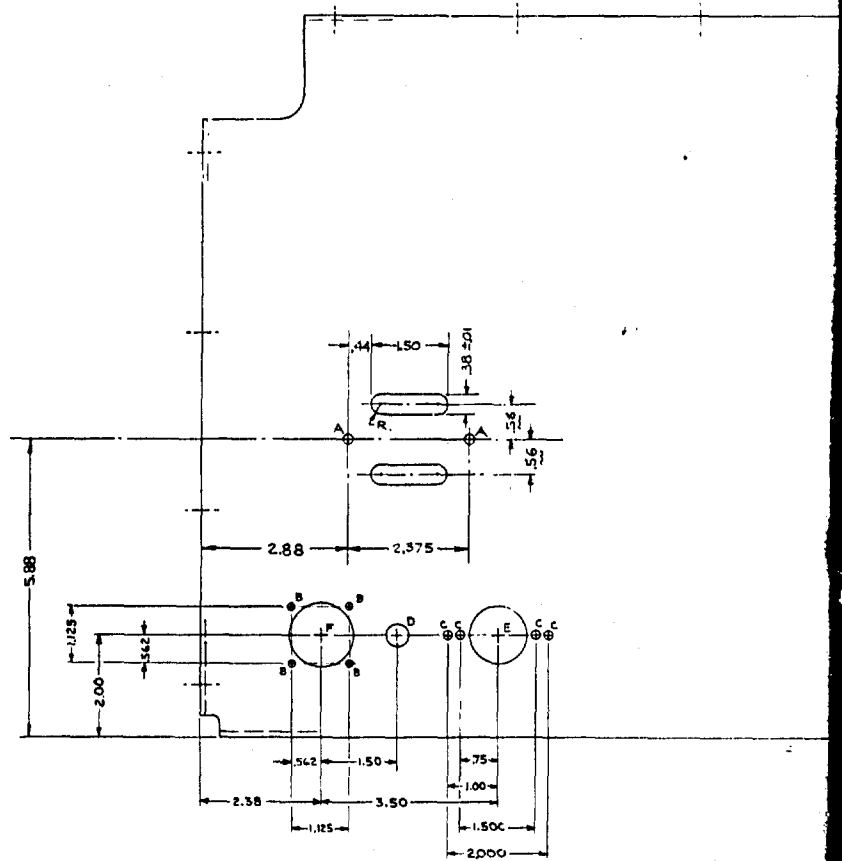
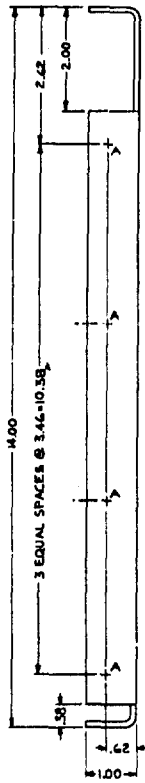
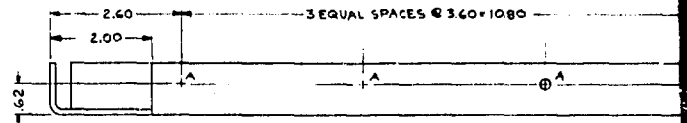

A

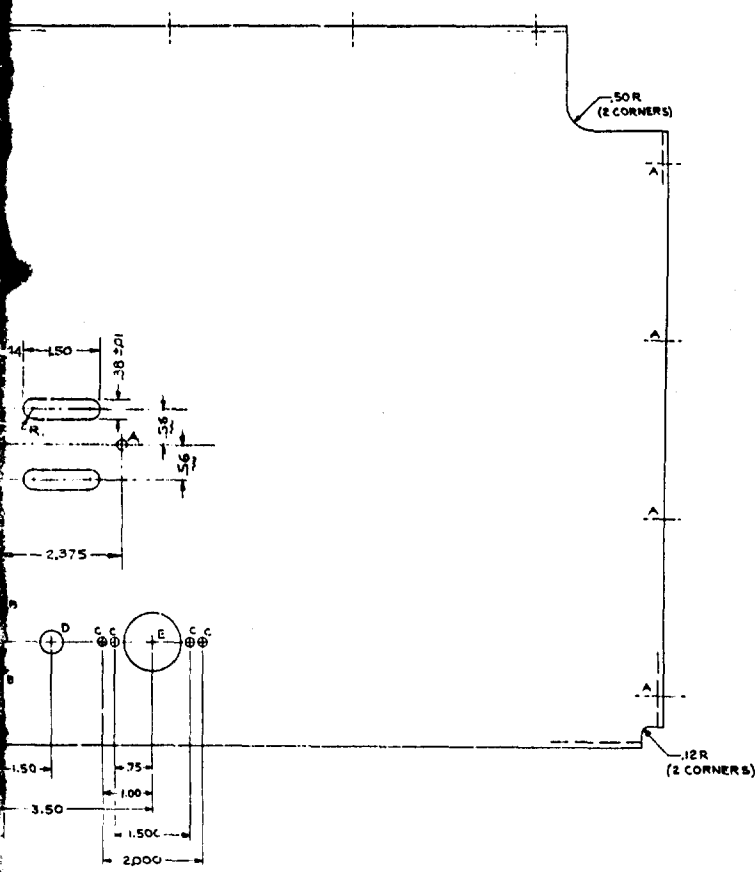
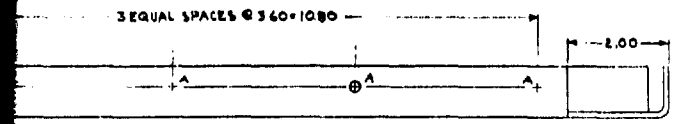

| HOLE | DESCRIPTION |
|------|-----------------|
| A | .204-.214 DIA |
| B | .155-.145 DIA |
| C | .168-.178 DIA |
| D | .483-.443 DIA |
| E | 1.129-1.141 DIA |
| F | 1.240-1.260 DIA |
| G | .237-.247 DIA |

NOTE:
ALL BEND RADII TO BE .09

LIST OF MATERIAL
ALUMINUM, ALLOY, SHEET,
.000 THK, TYPE 5052-H32

FINISH:
ALKALINE DIP (ROUGH ETCHED FROSTY-WHITE FINISH) THEN APPLY PROTECTIVE COATING (IRILAC #1000 ALLIED RESEARCH PROP, INC.)

Figure A-86. Shelf (E2205287)

A-87

B

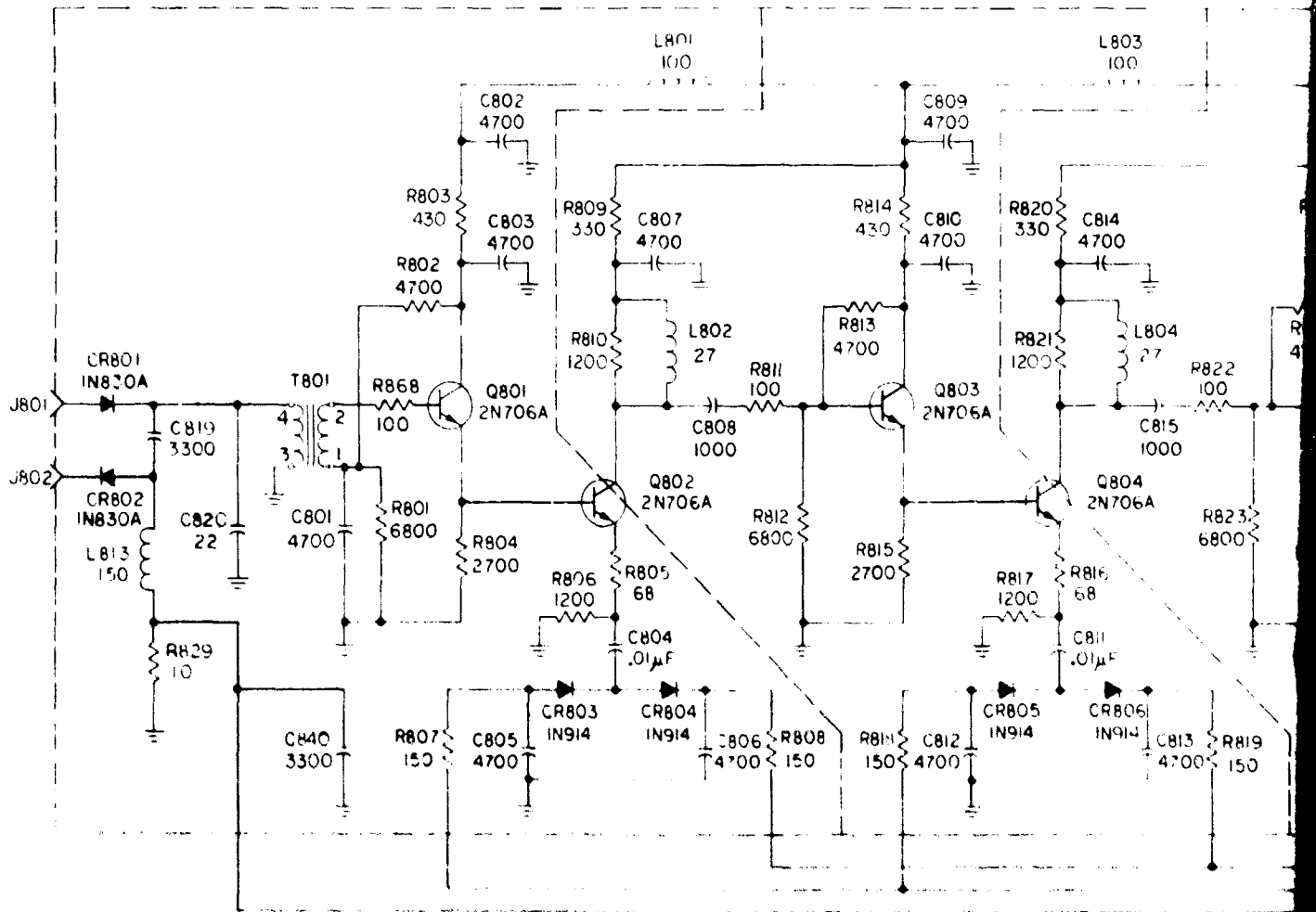

A

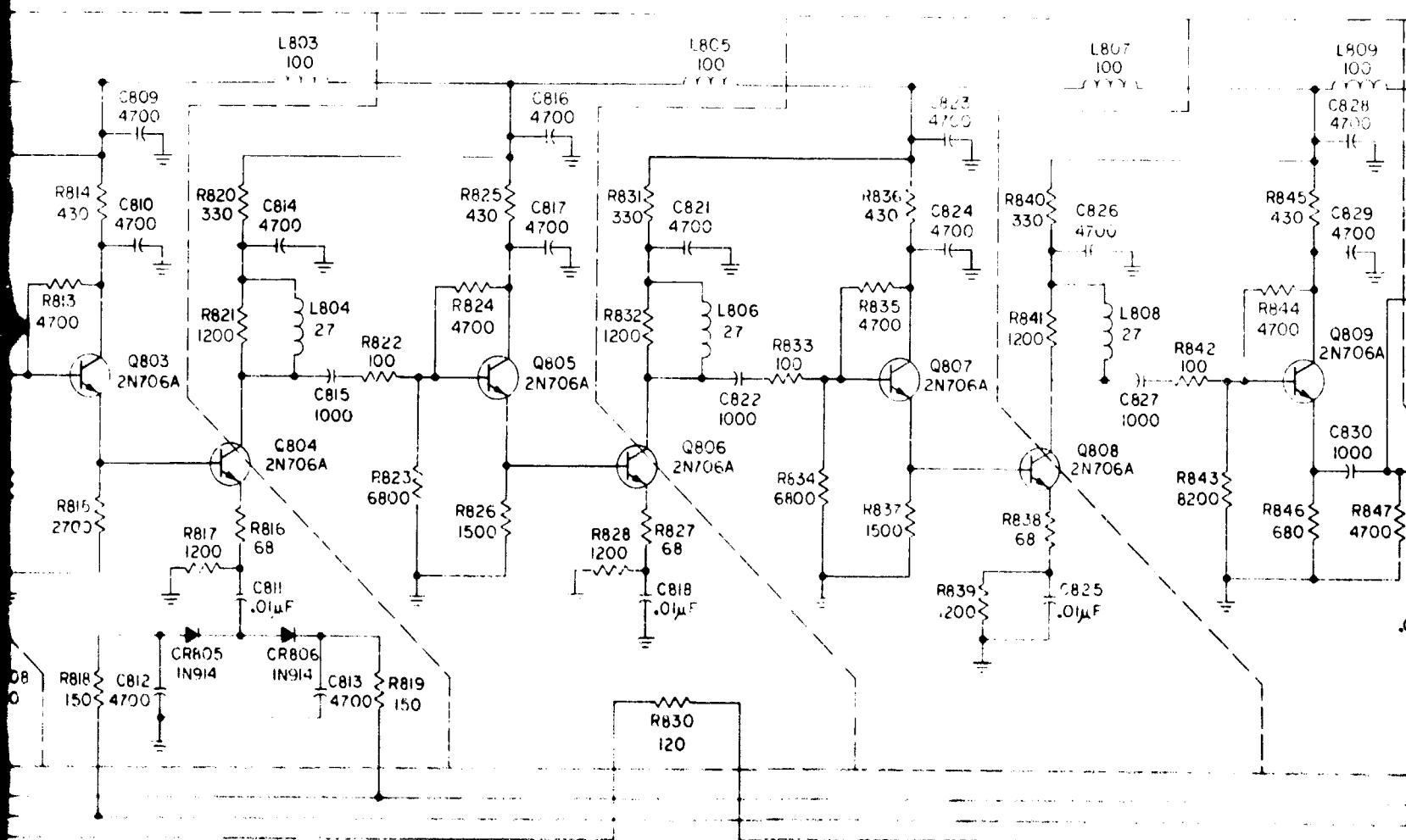

| HIGHEST REFERENCE DESIGNATIONS | | | | |
|---------------------------------|------|-------|------|------|
| R818 | C812 | CR805 | Q815 | L813 |
| REFERENCE DESIGNATIONS NOT USED | | | | |
| CR807 | | | | |

B

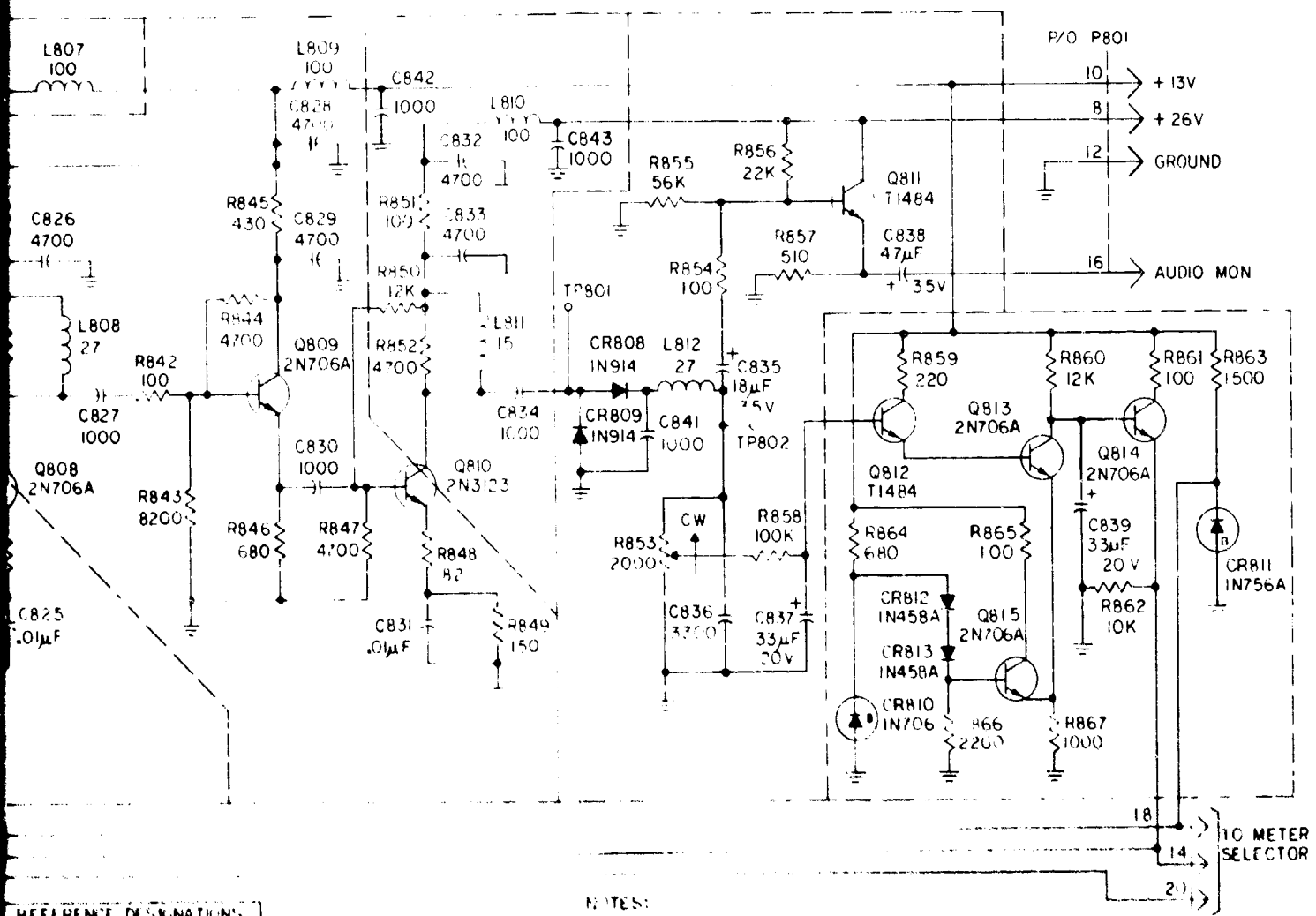

| REFERENCE DESIGNATIONS | |
|---------------------------|----------------|
| 43 | CR13 Q815 L813 |
| X F DESIGNATIONS NOT USED | |

NOTES:
 1. UNLESS OTHERWISE SPECIFIED
 RESISTANCE VALUES ARE IN OHMS.
 CAPACITANCE VALUES ARE IN PICOFARADS.
 INDUCTANCE VALUES ARE IN MICRohenries.

Figure A-87. Schematic Diagram,
 IF Amplifier GS Field Detector
 (J2205295)

C

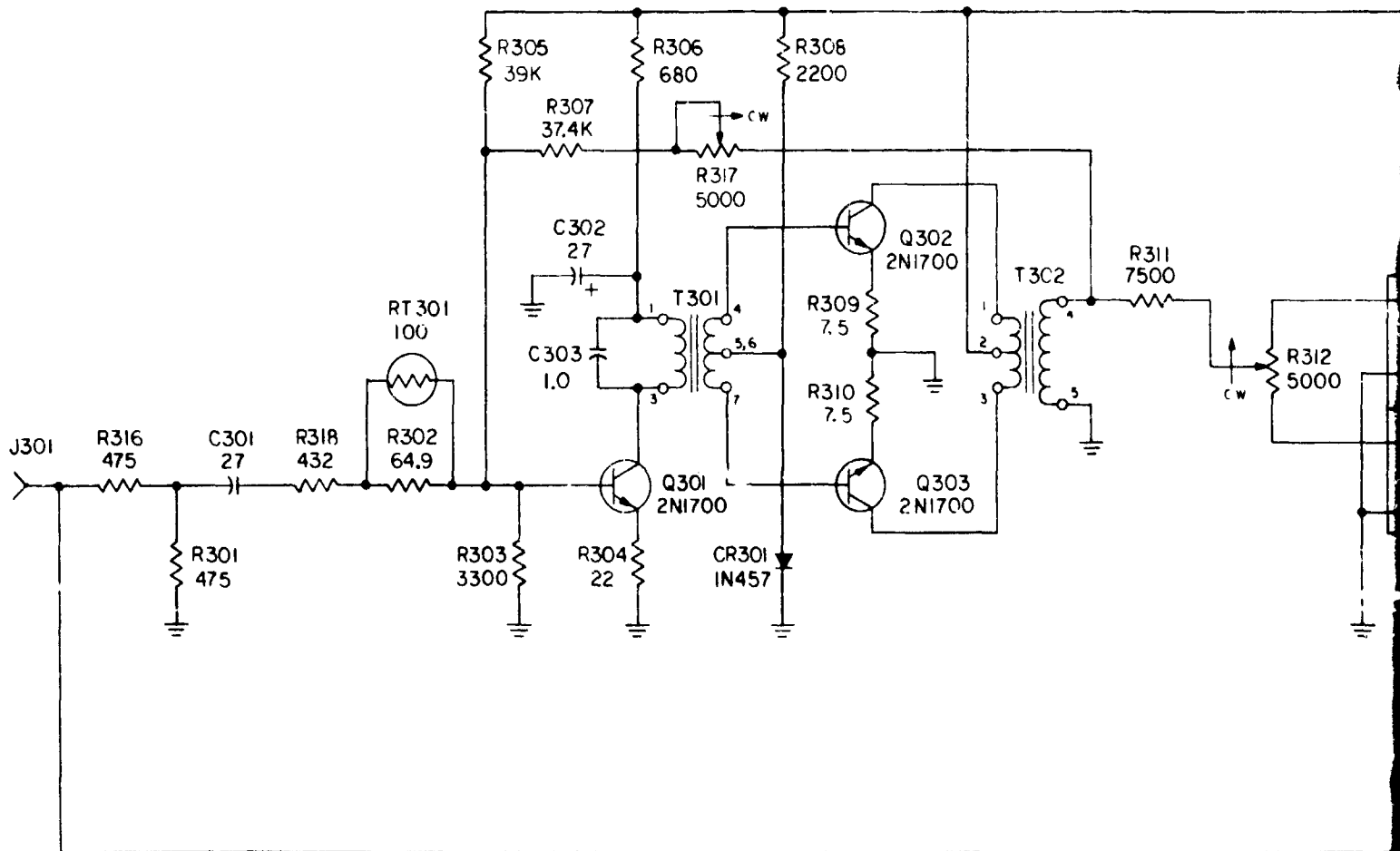

| HIGHEST REFERENCE DESIGNATIONS | | | | | |
|---------------------------------|-------|------|------|-------|--|
| C303 | CR305 | Q303 | R318 | RT301 | |
| REFERENCE DESIGNATIONS NOT USED | | | | | |
| | | | | | |

A

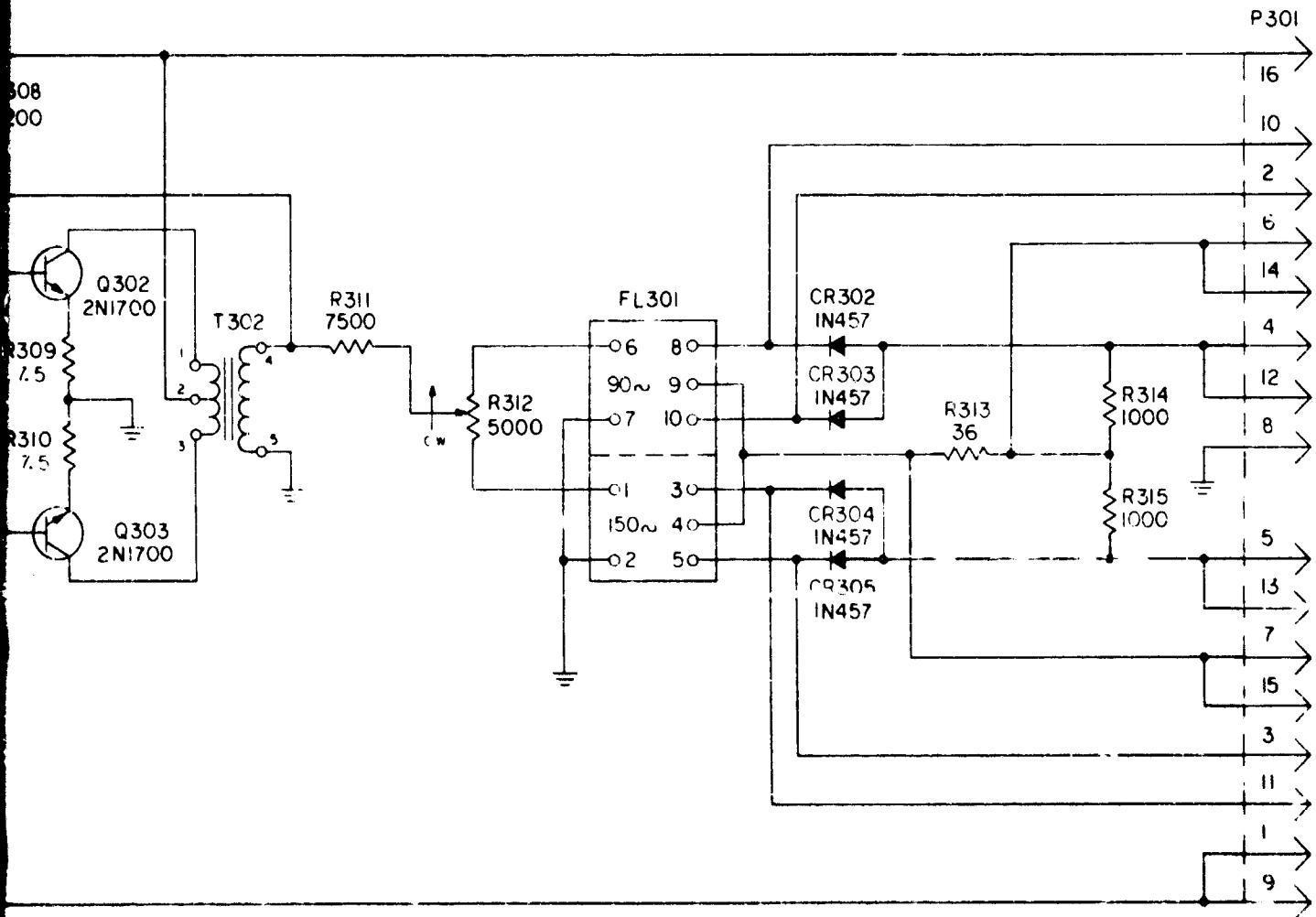

| HIGHEST REFERENCE DESIGNATIONS | | | | | |
|---------------------------------|-------|------|------|-------|--|
| 303 | CR305 | Q303 | R314 | RT301 | |
| REFERENCE DESIGNATIONS NOT USED | | | | | |
| | | | | | |

NOTES:
 1. UNLESS OTHERWISE SPECIFIED:
 RESISTANCE VALUES ARE IN OHMS.
 CAPACITANCE VALUES ARE IN MICROFARADS.

Figure A-88. Schematic Diagram, Audio Subunit Monitor Glide Slope Transmitter (E2205299)

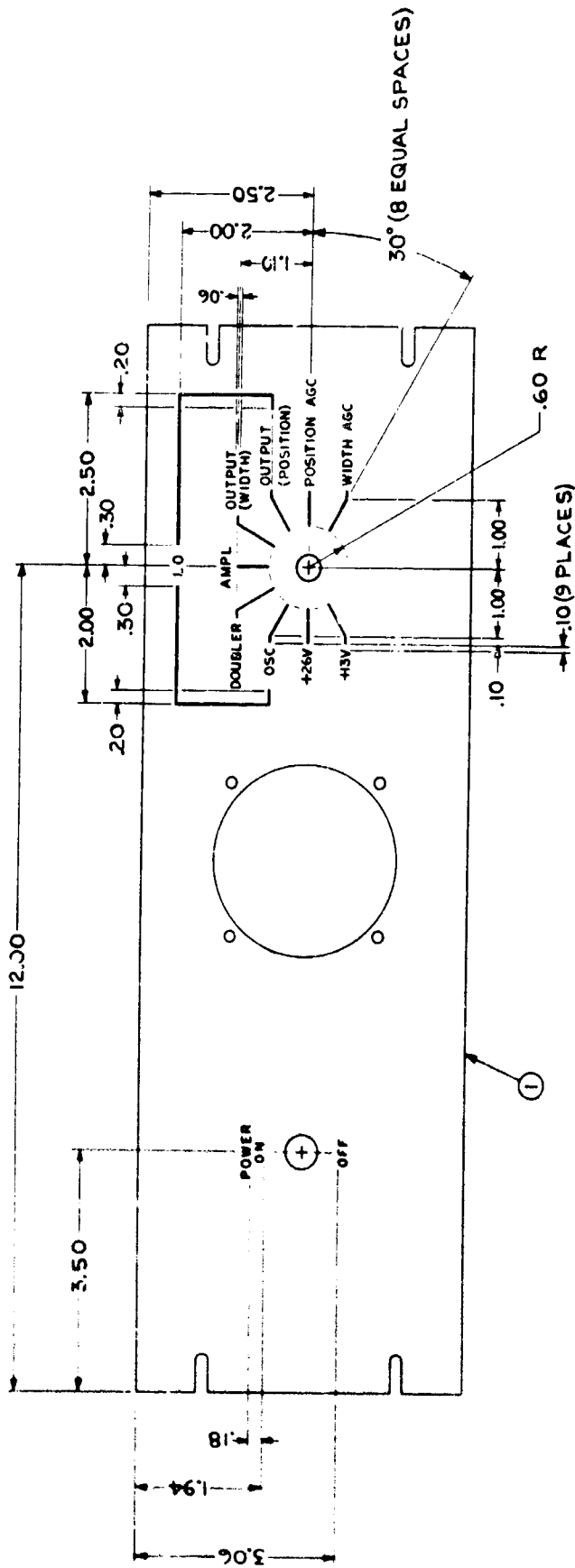

| LIST OF MATERIAL | | | |
|------------------|-----|-----|-------------------------|
| GROUP | QTY | UOM | PART OR IDENTIFYING NO. |
| 03 | 1 | EA | 2205220 |
| 20 | 2 | EA | 2205220 |
| 1 | 1 | EA | 2205199 |
| | | | PANEL METER (DRILLING) |

NOTES:

1. MARK PER A2205220 PARA 'B'; PAINT TO BE BLACK IN COLOR.
2. CHARACTERS TO BE 12 POINT UNLESS OTHERWISE SPECIFIED
3. ALL LINES TO BE .03 THK.

Figure A-89. Panel, Meter (Marking) (D2205306)

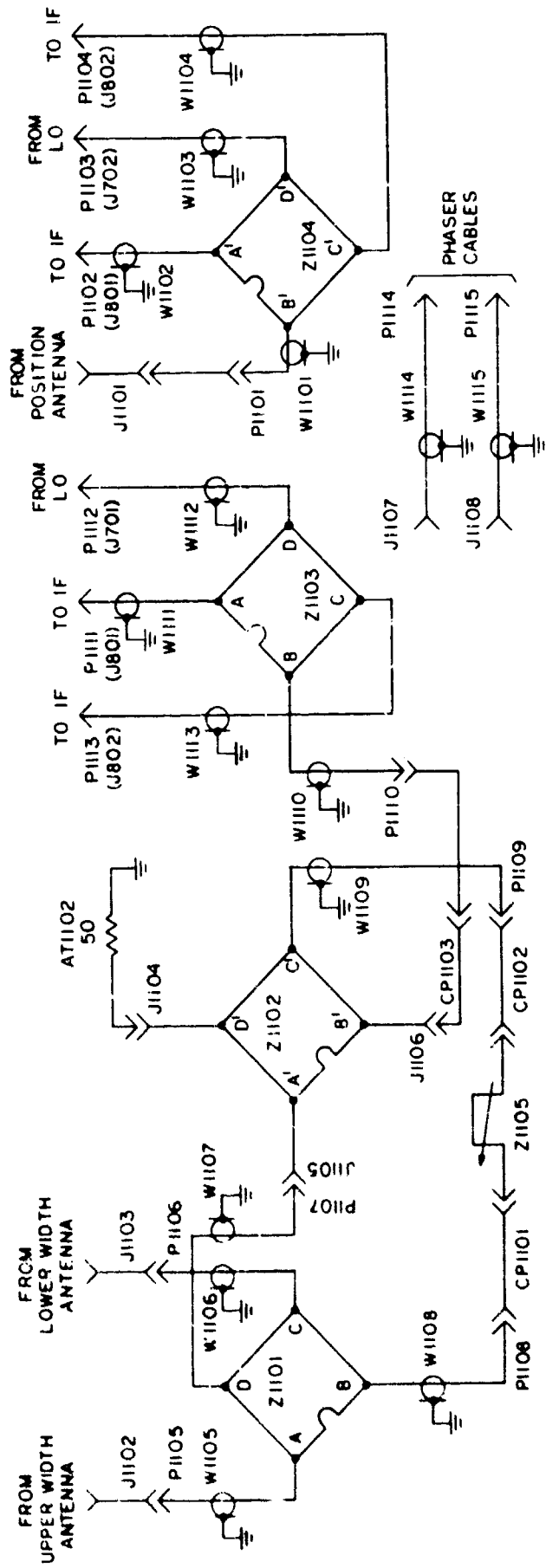

A-91

Figure A-90. Schematic Diagram, Antenna Phase Network G.S. Field Detector (D2205315)

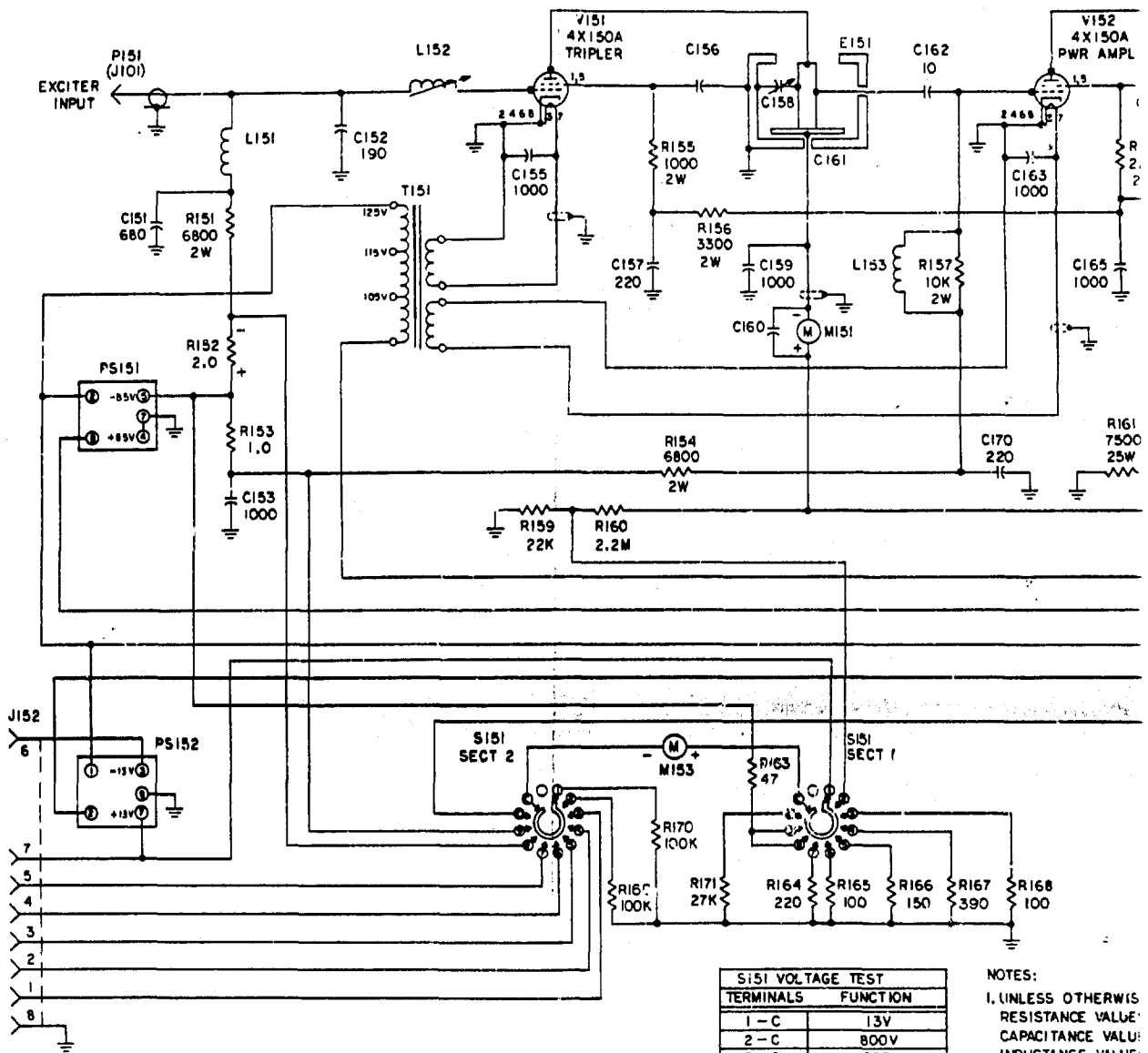

| HIGHEST REFERENCE DESIGNATIONS | | | | | | |
|---------------------------------|------|------|------|------|------|------|
| C172 | L153 | J152 | M153 | R171 | S152 | V152 |
| REFERENCE DESIGNATIONS NOT USED | | | | | | |
| | | | | | | |

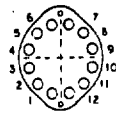

| S151 VOLTAGE TEST | |
|-------------------|---------------|
| TERMINALS | FUNCTION |
| 1 - C | 13V |
| 2 - C | 800V |
| 3 - C | OSC |
| 4 - C | 1ST DOUBLER |
| 5 - C | 2ND DOUBLER |
| 6 - C | 1ST AMPLIFIER |
| 7 - C | 2ND AMPLIFIER |
| 8 - C | TRIPLER GRID |
| 9 - C | PWR AMPL GRID |
| 10 - C | R F LEVEL |

NOTES:
 1. UNLESS OTHERWISE RESISTANCE VALUE, CAPACITANCE VALUE, INDUCTANCE VALUE.
 2. TERMINAL NUMBER REFERENCE ONLY. TERMINAL IS SHOWN SWITCH IS SHOWN KNOB IN EXTREME

A

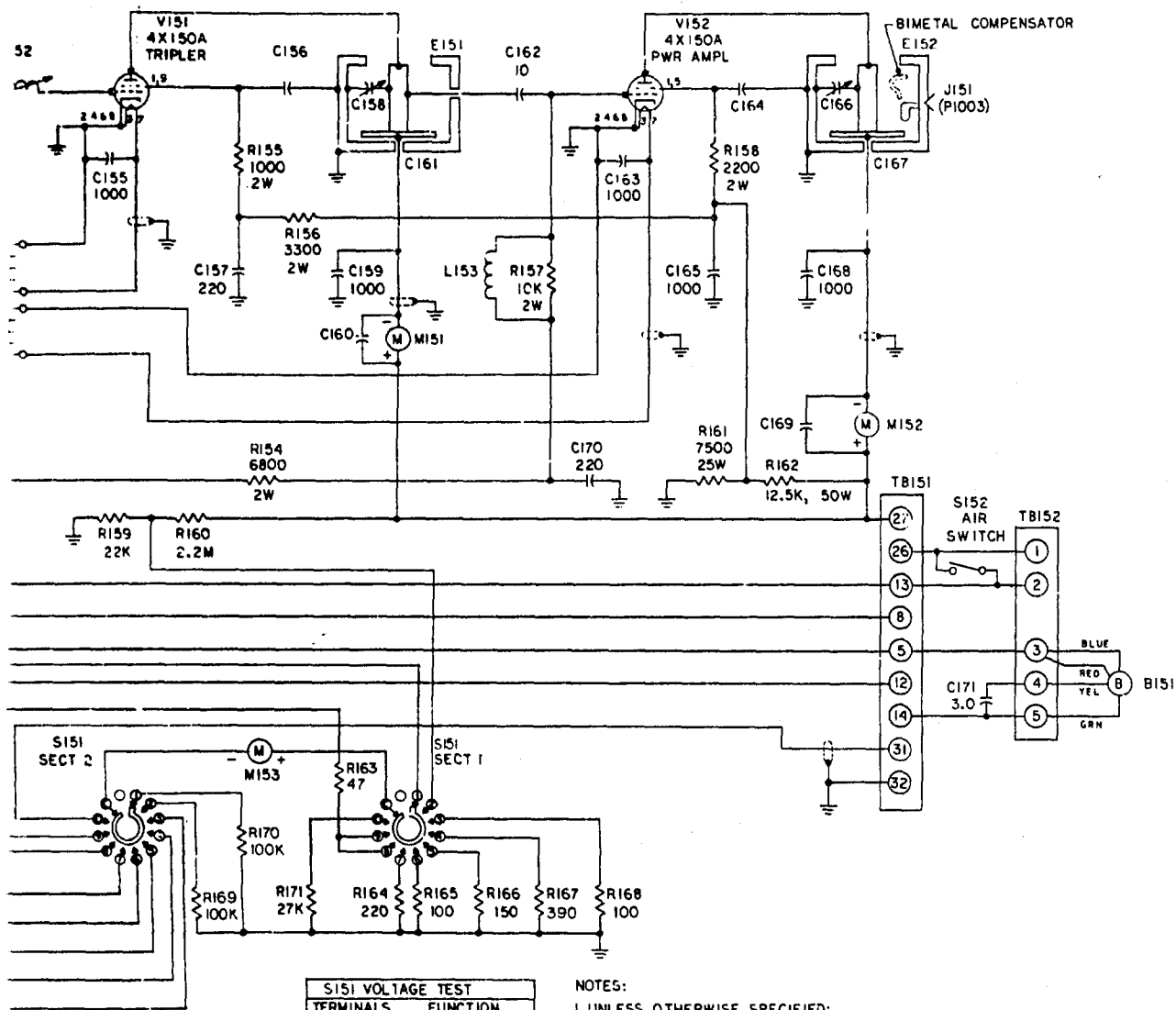

| S151 VOLTAGE TEST | |
|-------------------|---------------|
| TERMINALS | FUNCTION |
| 1-C | 13V |
| 2-C | 80V |
| 3-C | OSC |
| 4-C | 1ST DOUBLER |
| 5-C | 2ND DOUBLER |
| 6-C | 1ST AMPLIFIER |
| 7-C | 2ND AMPLIFIER |
| 8-C | TRIPLER GRID |
| 9-C | PWR AMPL GRID |
| 10-C | R F LEVEL |

NOTES:

- UNLESS OTHERWISE SPECIFIED:
RESISTANCE VALUES ARE IN OHMS.
CAPACITANCE VALUES ARE IN MICROFARADS.
INDUCTANCE VALUES ARE IN MICROHENRIES.
- TERMINAL NUMBERING FOR S151 IS FOR REFERENCE ONLY. RELATIVE LOCATION OF TERMINAL IS SHOWN IN DIAGRAM AT LEFT. SWITCH IS SHOWN VIEWED FROM FRONT WITH KNOB IN EXTREME CCW POSITION.

| |
|------------|
| VARIATIONS |
| T152 |
| T USED |

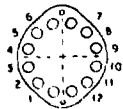
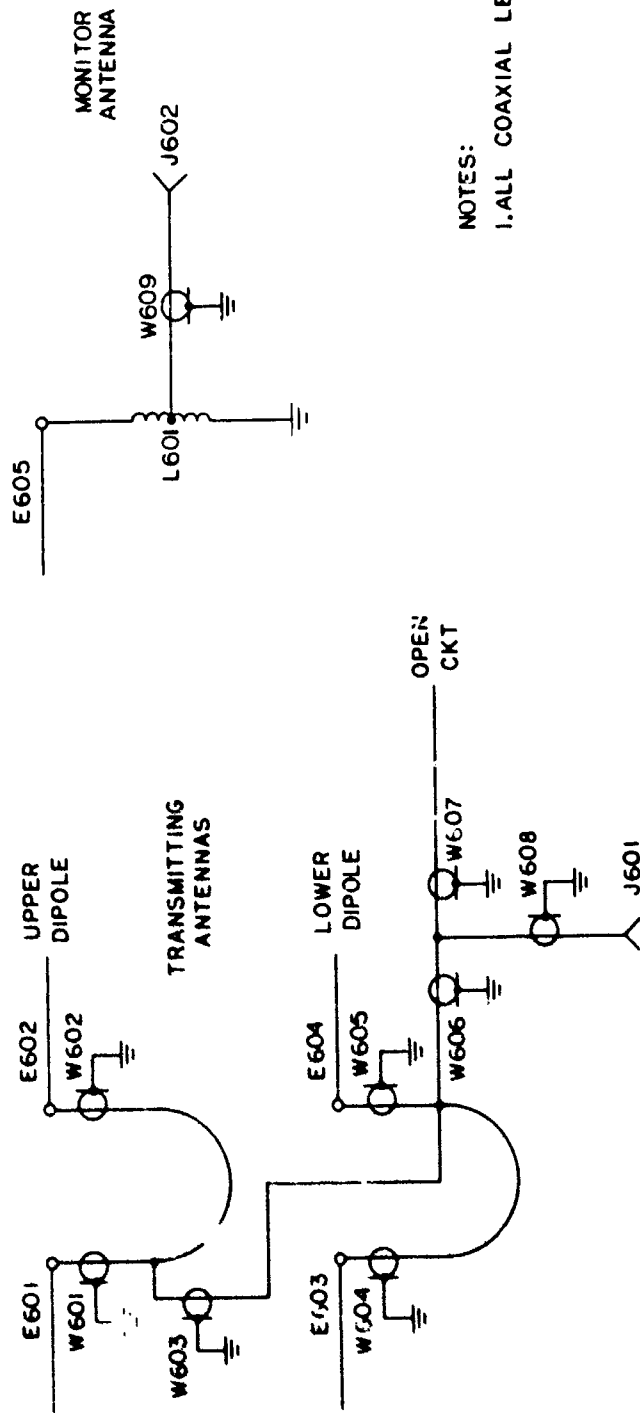

Figure A-91. Schematic Diagram,
Transmitter Glide Slope Transmitter
(E2205316)

B



NOTES:
 1. ALL COAXIAL LEADS ARE RG223/U.

A-93

Figure A-92. Schematic Diagram, Antenna Marker Beacon (D2205318)

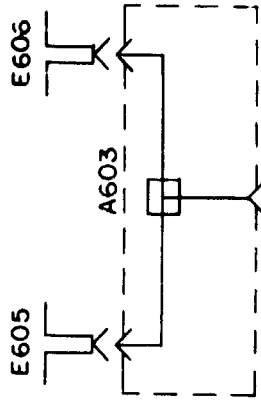
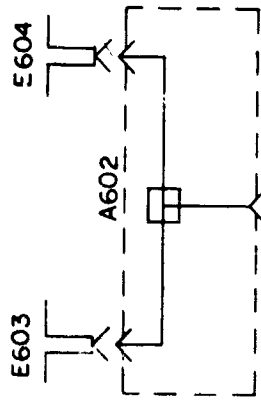
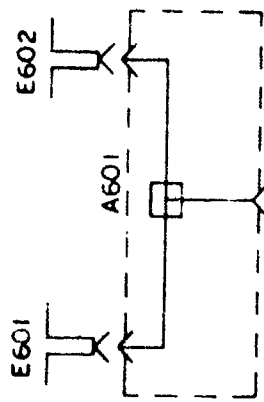

A-94

Figure A-93. Schematic Diagram, Transmitting Antenna Glide Slope Transmitter (D2205319)

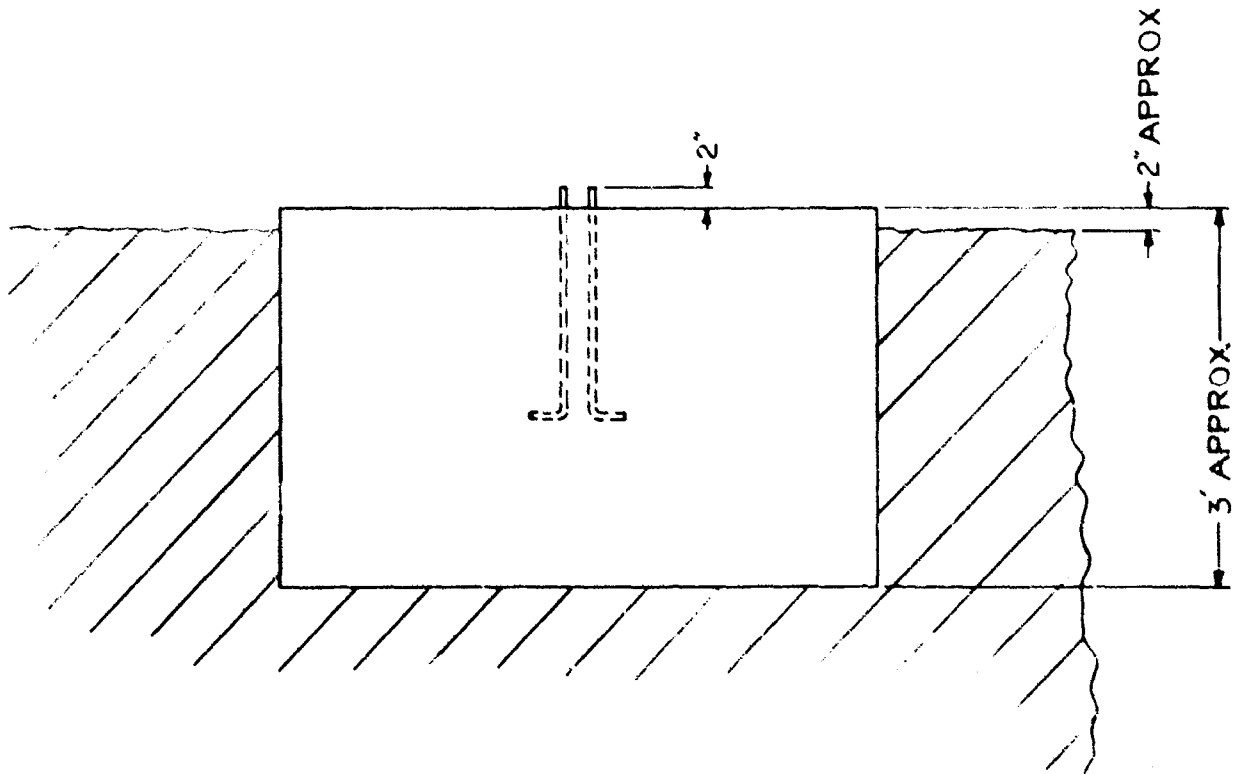
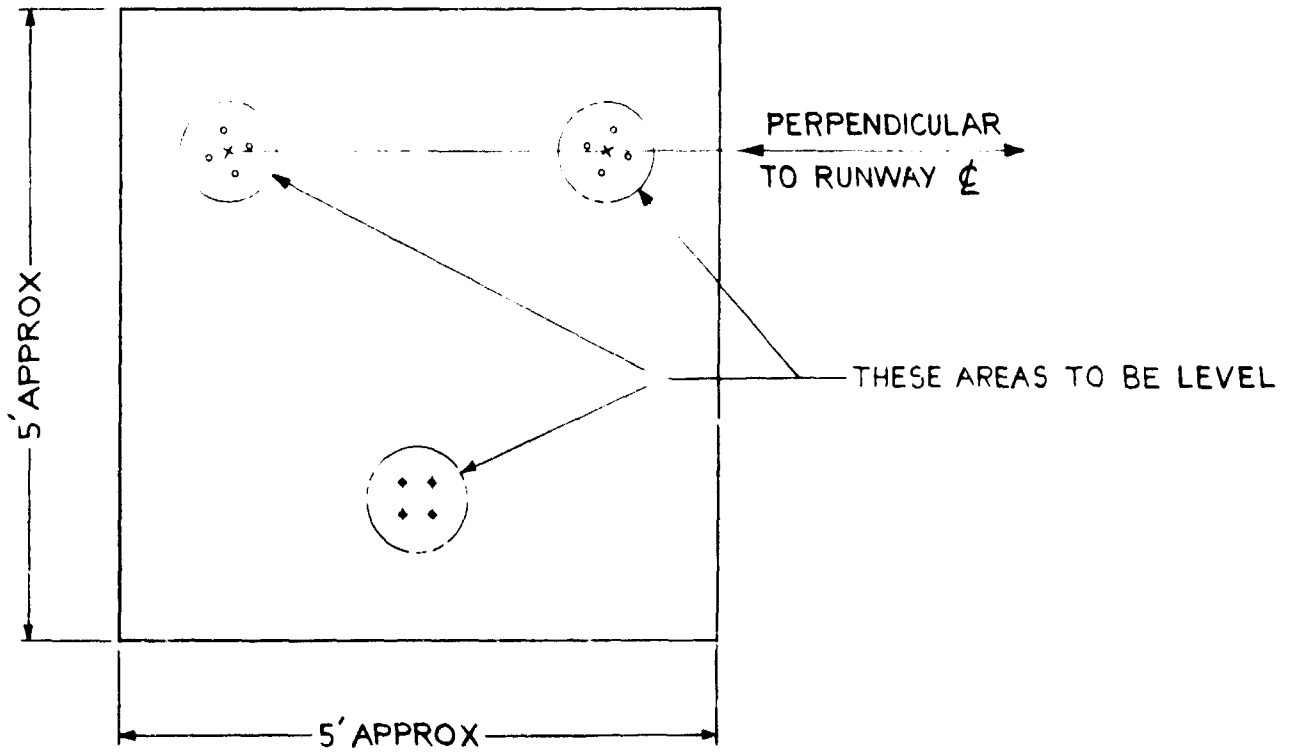

A

AS TO BE LEVEL

3' APPROX

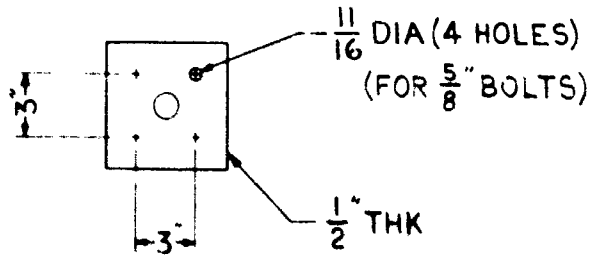
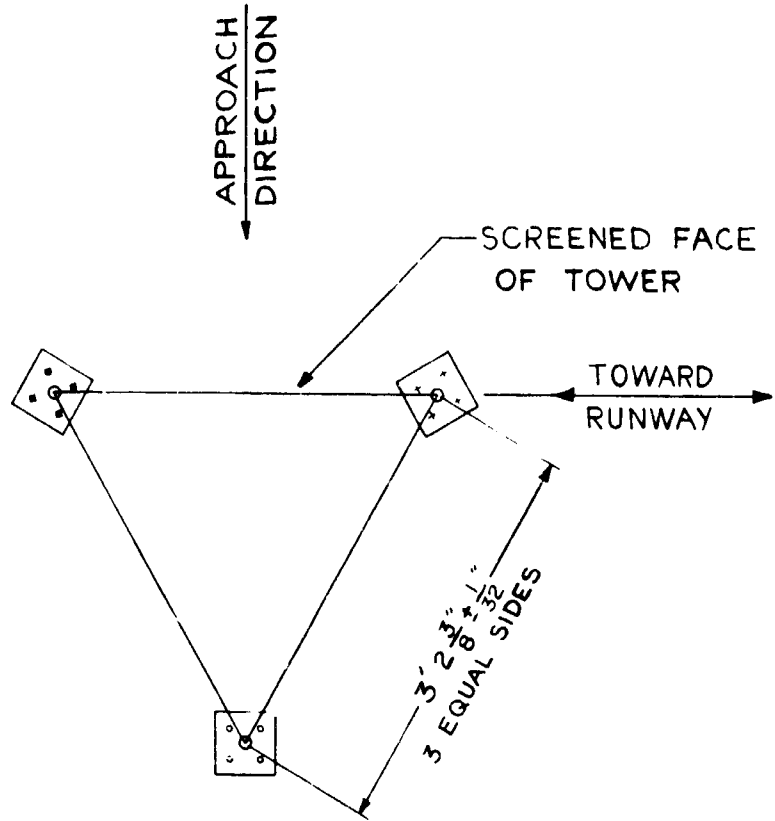
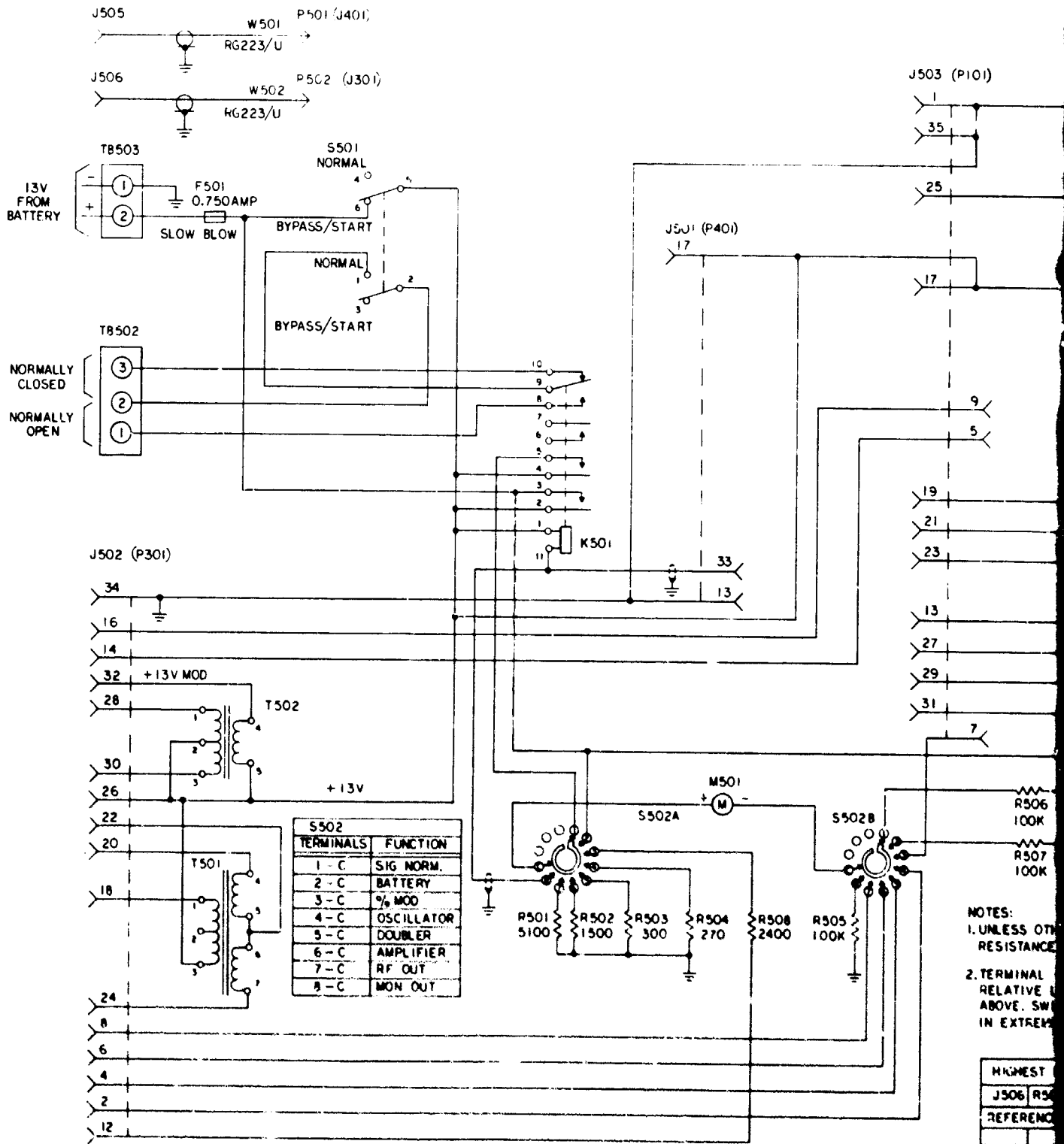

Figure A-94. Base Antenna (D2367300)

A-95

B



Fig

A

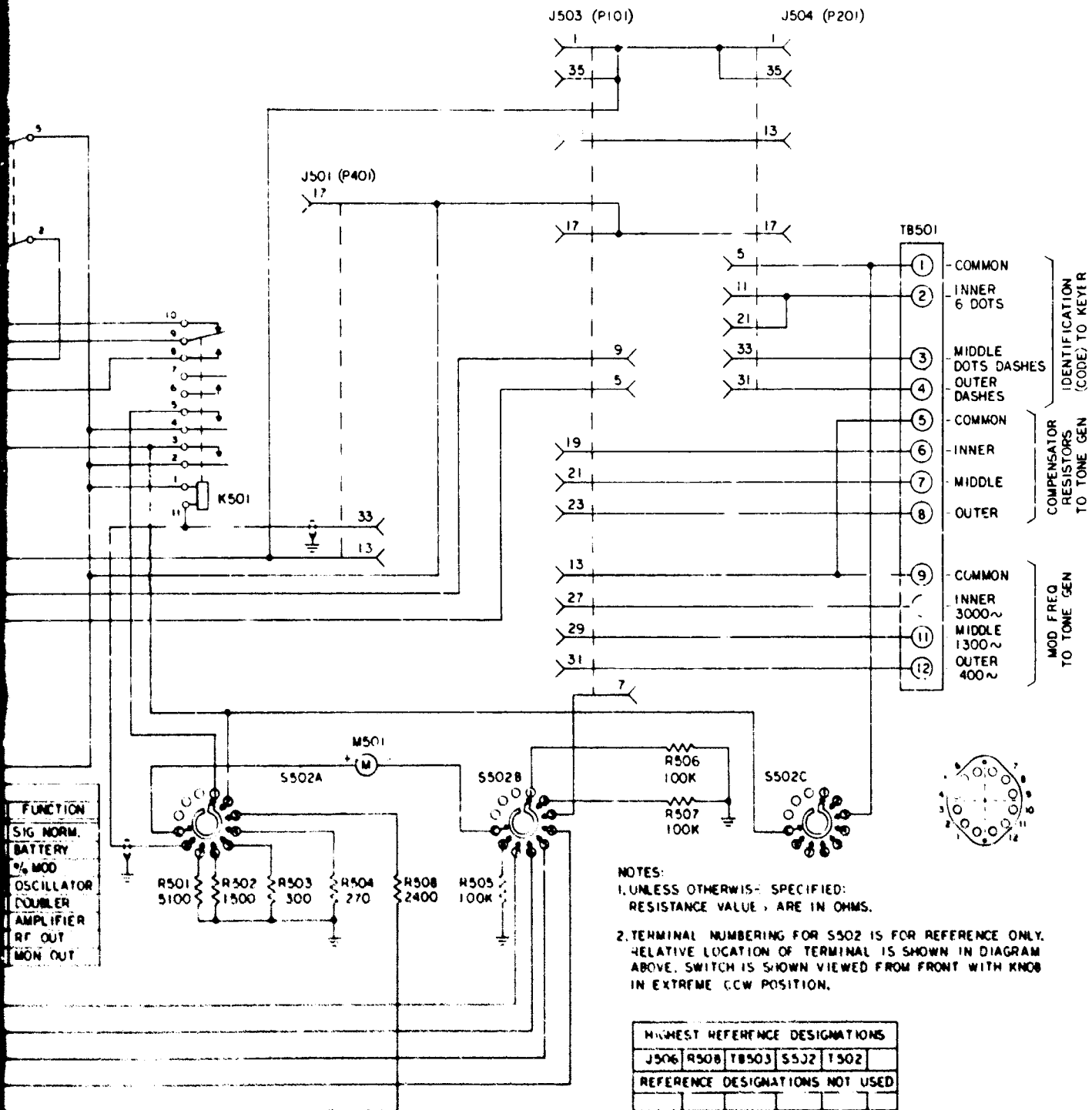
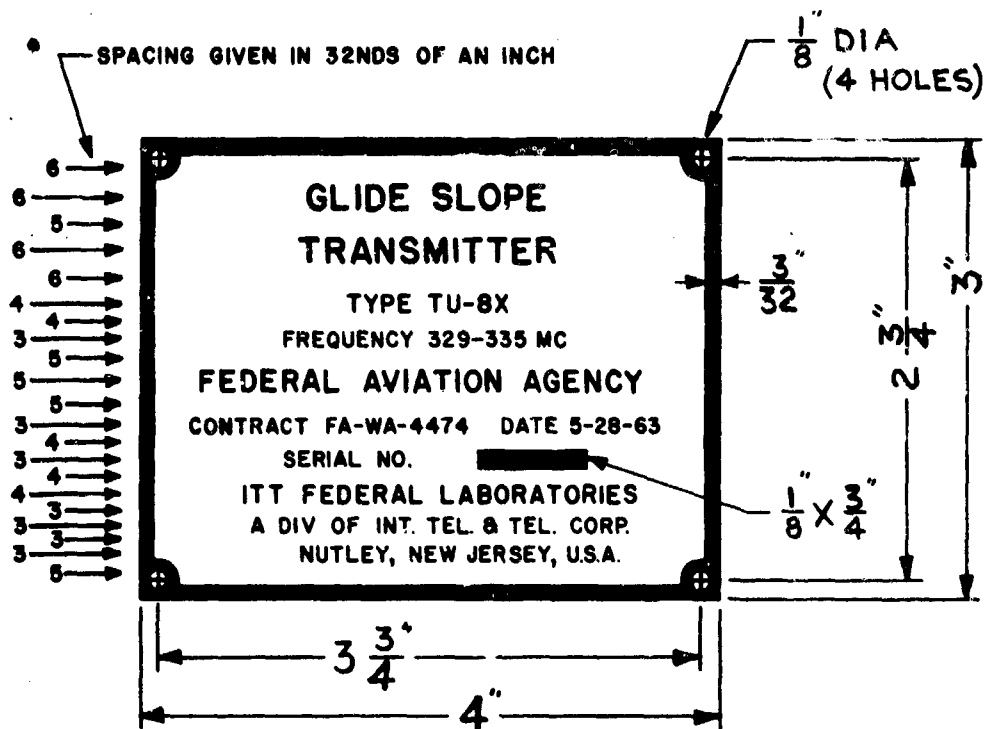

Figure A-95. Schematic Diagram, Intra Cabinet Wiring Marker Beacon (E2205321)



NOTES:

1. MATERIAL: .032" ALUMINUM WITH OVERALL WATER-DIP-LACQUER FINISH.
2. REVERSE ETCH; THE FOLLOWING TO BE RAISED, WITH DULL METAL FINISH: BORDER, SERIAL NUMBER BLANK, AND ALL LETTERS AND NUMBERS EXCEPT SERIAL NUMBER; DEPRESSED BACKGROUND FINISHED IN BLACK ENAMEL.
3. SERIAL NUMBER: ENGRAVE OR DIE STAMP.
4. TOLERANCE ON DIMENSIONS $\pm .010$ " EXCEPT HOLE SIZE & HOLE-TO-HOLE SPACING $\pm .005$ ".

Figure A-96. Nameplate (A2205322)

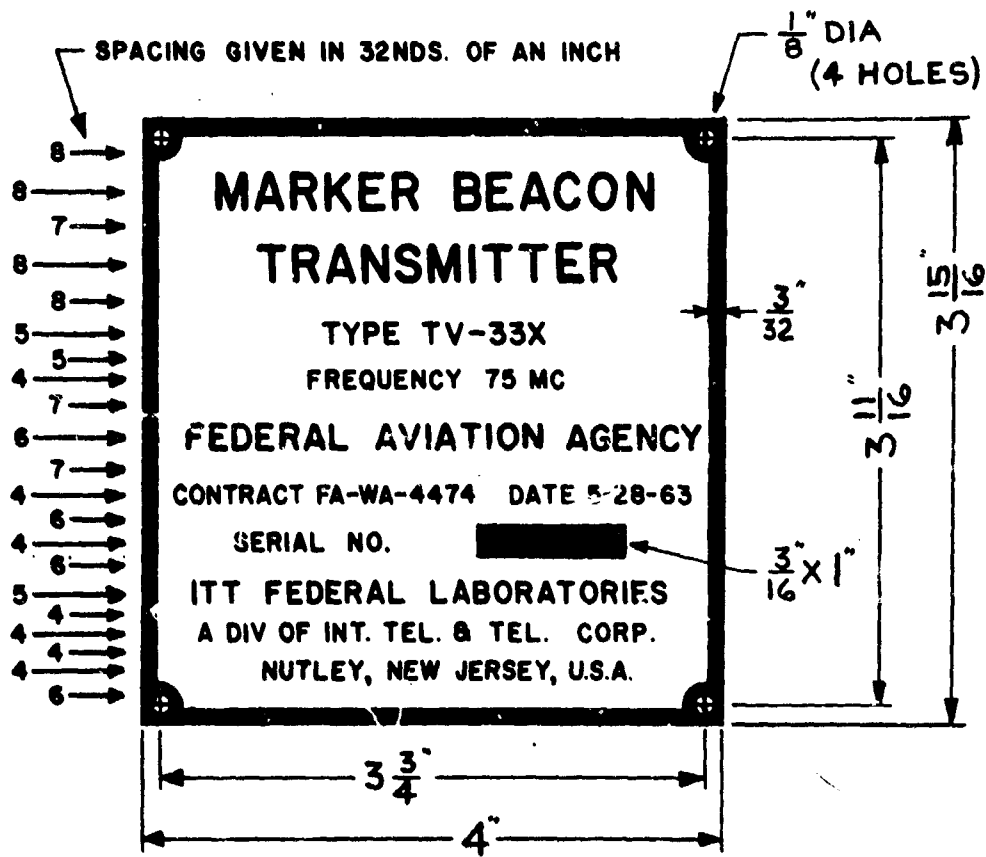

NOTES:

1. MATERIAL: .032" ALUMINUM WITH OVERALL WATER-DIP-LACQUER FINISH.
2. REVERSE ETCH; THE FOLLOWING TO BE RAISED, WITH DULL METAL FINISH: BORDER, SERIAL NUMBER BLANK, AND ALL LETTERS AND NUMBERS EXCEPT SERIAL NUMBER; DEPRESSED BACKGROUND FINISHED IN BLACK ENAMEL.
3. SERIAL NUMBER: ENGRAVE OR DIE STAMP.
4. TOLERANCE ON DIMENSIONS $\pm .010$ " EXCEPT HOLE SIZE & HOLE-TO-HOLE SPACING $\pm .005$ ".

Figure A-97. Nameplate (A2205323)

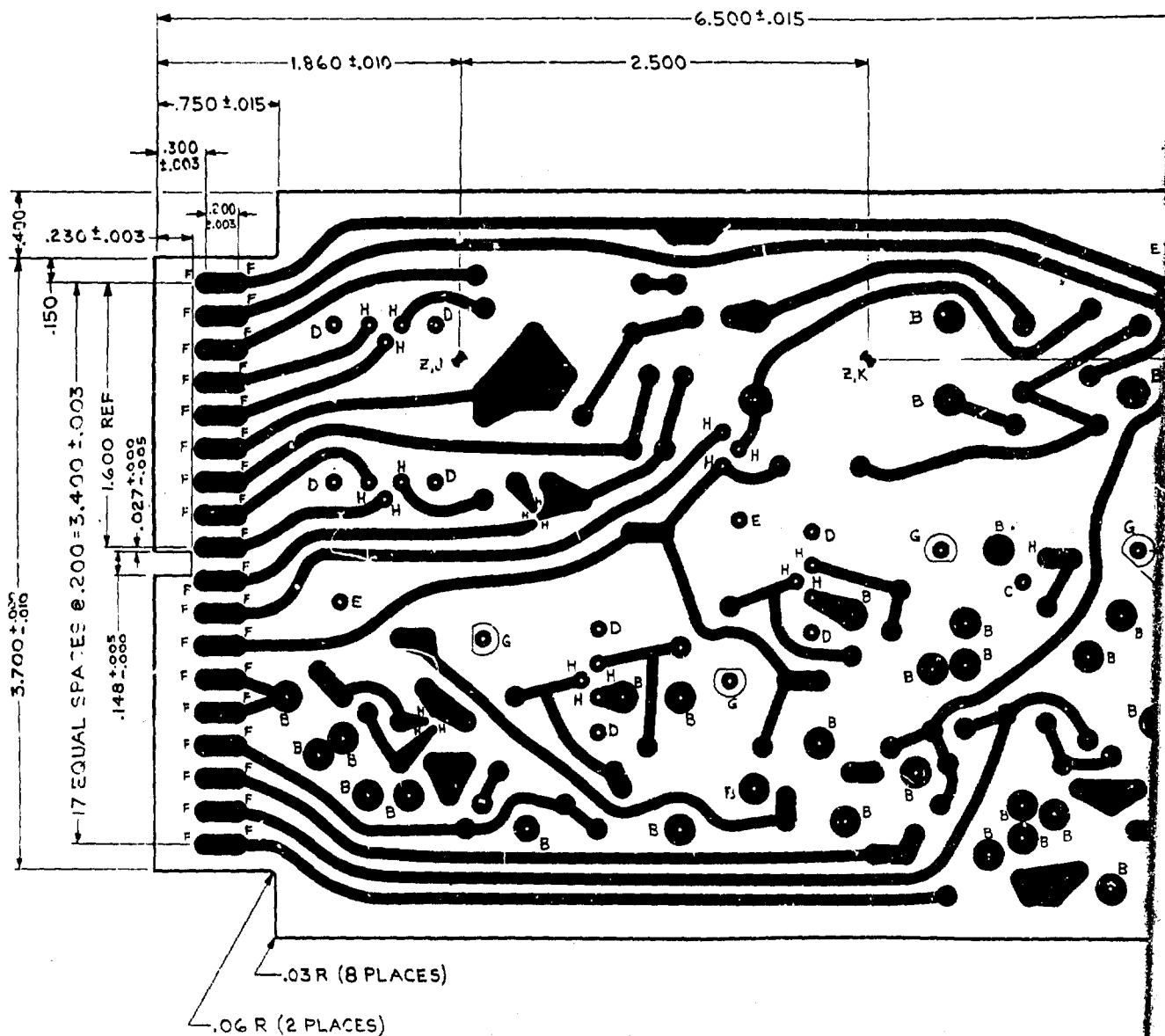

NOTES:

1. UNLESS A DIMENSION OR TOLERANCE IS SPECIFICALLY STATED, HOLE CENTERS SHALL BE LOCATED AS FOLLOWS.
 - (A) FOR HAND INSERTION OF PARTS, WITHIN .008 OF THE TRUE .10 OR .025 COORDINATE GRID POSITION.
 - (B) FOR MACHINE INSERTION OF PARTS, WITHIN .002 OF THE TRUE .10 OR .025 COORDINATE GRID POSITION, AND, IF TOOL HOLE CENTER REFERENCE POINTS OR THE BOARD REFERENCE EDGES (WHICHEVER IS APPLICABLE) ARE OFFSET FROM THE TRUE COORDINATE GRID, THIS OFFSET SHALL BE UNIFORM WITHIN ± .001 FOR ANY GIVEN LOT OF BOARDS.
2. EACH PRODUCTION ORDER SHALL STATE THE HOLE POSITION TOLERANCE APPLICABLE FOR THAT SPECIFIC MANUFACTURING LOT.
3. TRIM BOARD ALONG INSIDE EDGE OF TRIM LINE. MAINTAIN DIMENSIONS WITHIN SPECIFIED LIMITS. AFTER TRIMMING REMOVE ALL EXCESS COPPER ALONG THE EDGE.
4. FOR MASTER ART SEE SHEET #13 OF THIS DRAWING. FABRICATED PRINTED WIRING PATTERN SHALL MEET THE REQUIREMENTS OF SPECIFICATION #

5. MATERIAL: GLASS FABRIC BASE, EPOXY PLASTIC SHEET, LAMINATED .062 THK, DOUBLE COPPER CLAD WITH 2 OZ COPPER, TYPE DESIGNATION GF .062 2% PER SPECIFICATION MIL-P-13949C.
6. AFTER ETCHING AND DRILLING, APPLY SOLDER COAT .003 THICK MINIMUM TO ALL COPPER SURFACES.
7. AFTER SHEARING, FINE SAND ALL EDGES OF BOARD.

A

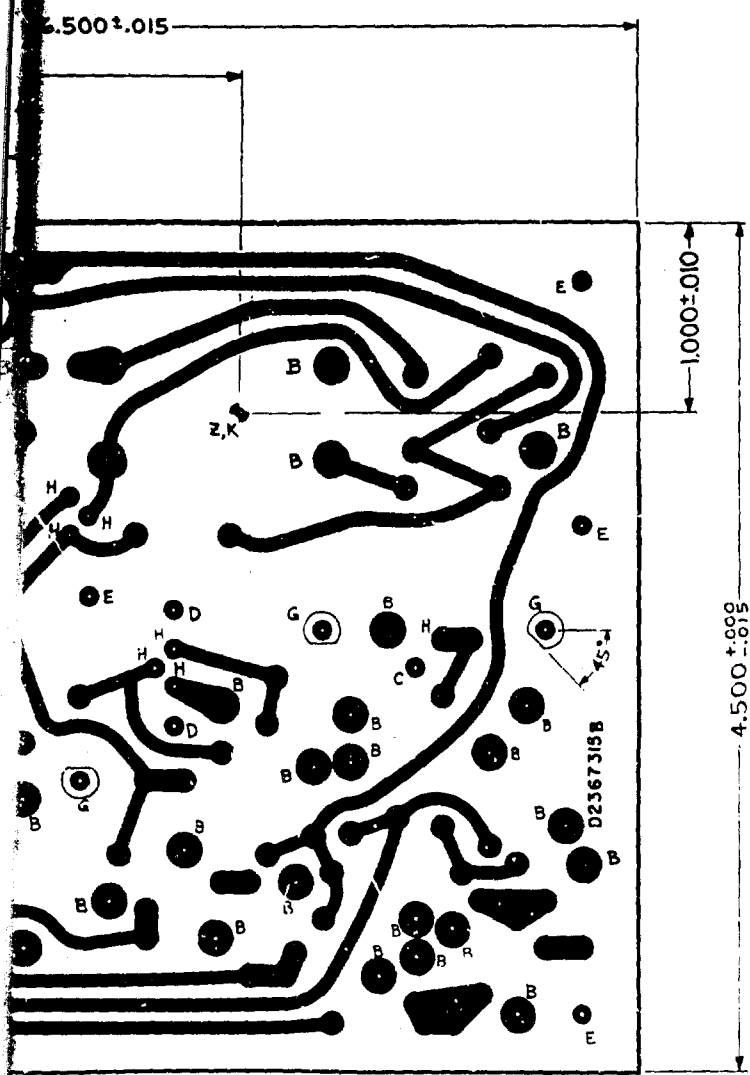

| HOLE | DESCRIPTION |
|-------|---------------|
| ** A | .047-.055 DIA |
| *** B | .053-.061 DIA |
| C | .088-.094 DIA |
| D | .135-.145 DIA |
| E | .168-.178 DIA |
| F | .048-.052 DIA |
| G | DD-0190 |
| H | .033-.040 DIA |
| J | .122-.131 DIA |
| K | .182-.191 DIA |

Z USE FOR TOOL HOLES
 ** ALL HOLES NOT MARKED ARE "A" HOLES.
 *** ALL "B" HOLES ARE PLATED THRU HOLES.

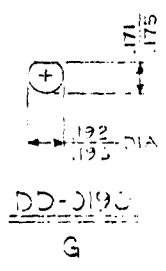

FRIC BASE, EPOXY PLASTIC SHEET,
 K, DOUBLE COPPER CLAD WITH 2 OZ
 SIGNATION GE 020 02/0 PER
 P-13949C
 DRILLING, APPLY SOLDER COAT
 UM TO ALL COPPER SURFACES.
 FINE SAND ALL EDGES OF BOARD

Figure A-98. Printed Wiring Board
 (Drilled) (D2367315)(Sheet 1 of 3)

A-99

B

REDUCE TO
8.000 ± .010

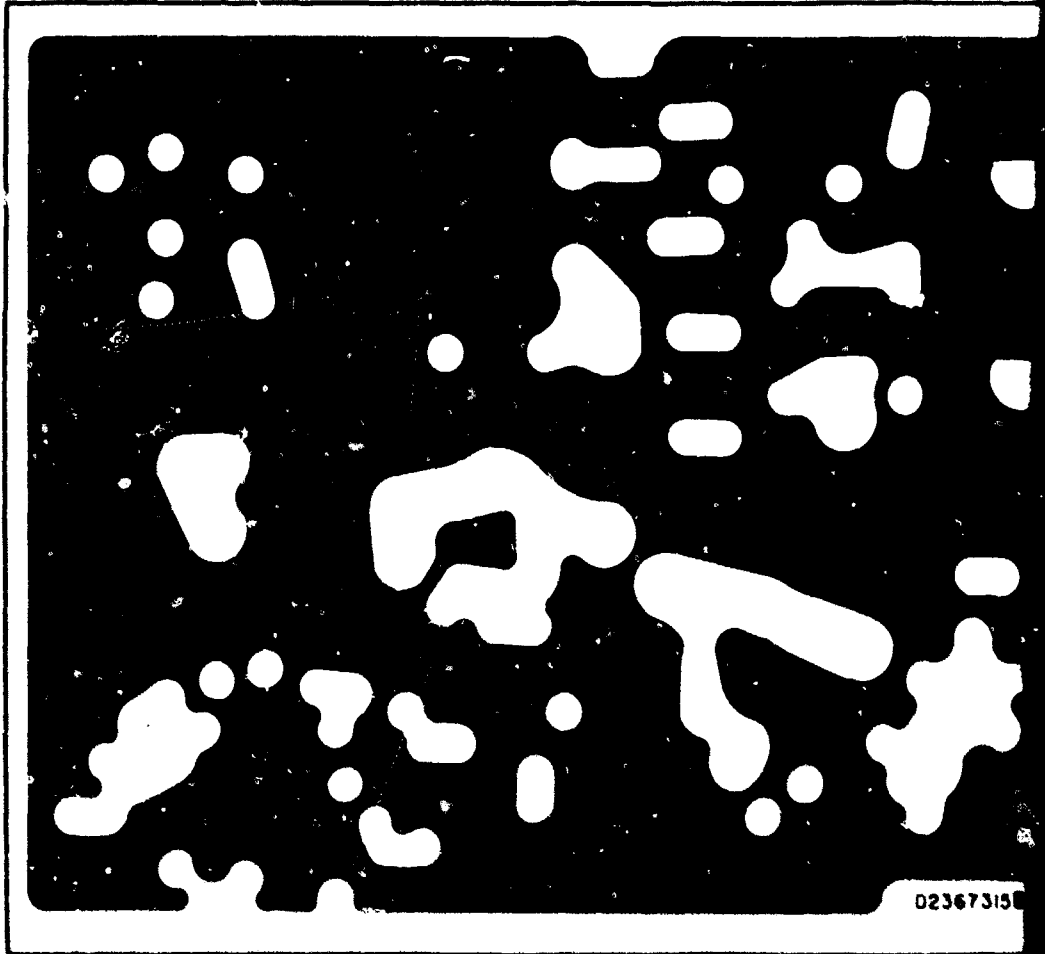

FACE
SEE SHEET 3 FOR OTHER SIDE

A

THE ORIGINAL MASTER ART (OR A REPRODUCTION PREPARED BY A METHOD WHICH WILL ASSURE DIMENSIONAL STABILITY) IS AN ACCURATE ENLARGED SCALE MASTER FOR PRODUCTION OF THE DEPICTED ITEM.
PRINTS OF THIS DRAWING ARE FOR REFERENCE ONLY.

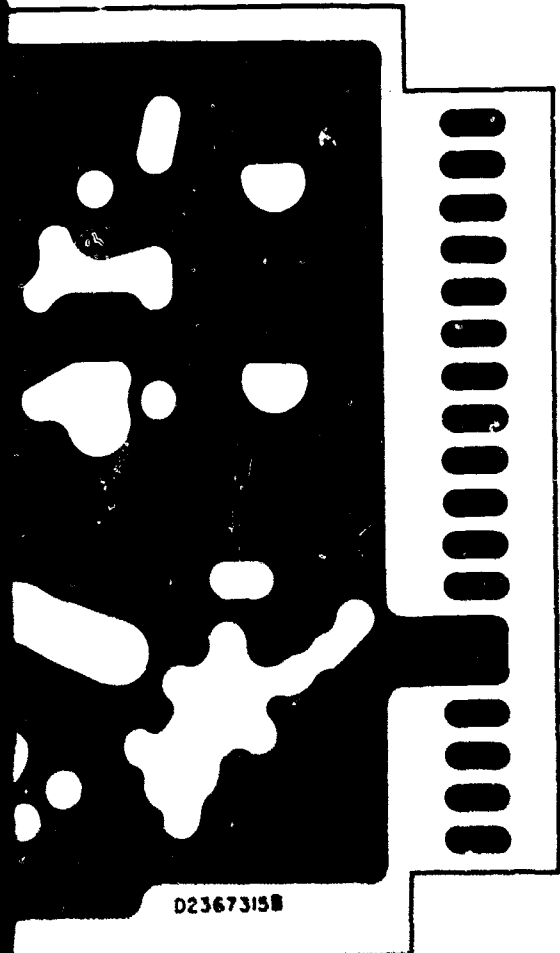

D2367315B

HER SIDE

Figure A-98. Printed Wiring Board
(Master) (D2367315) (Sheet 2 of 3)

A-100

B

REDUCE TO
8.000 ± .010

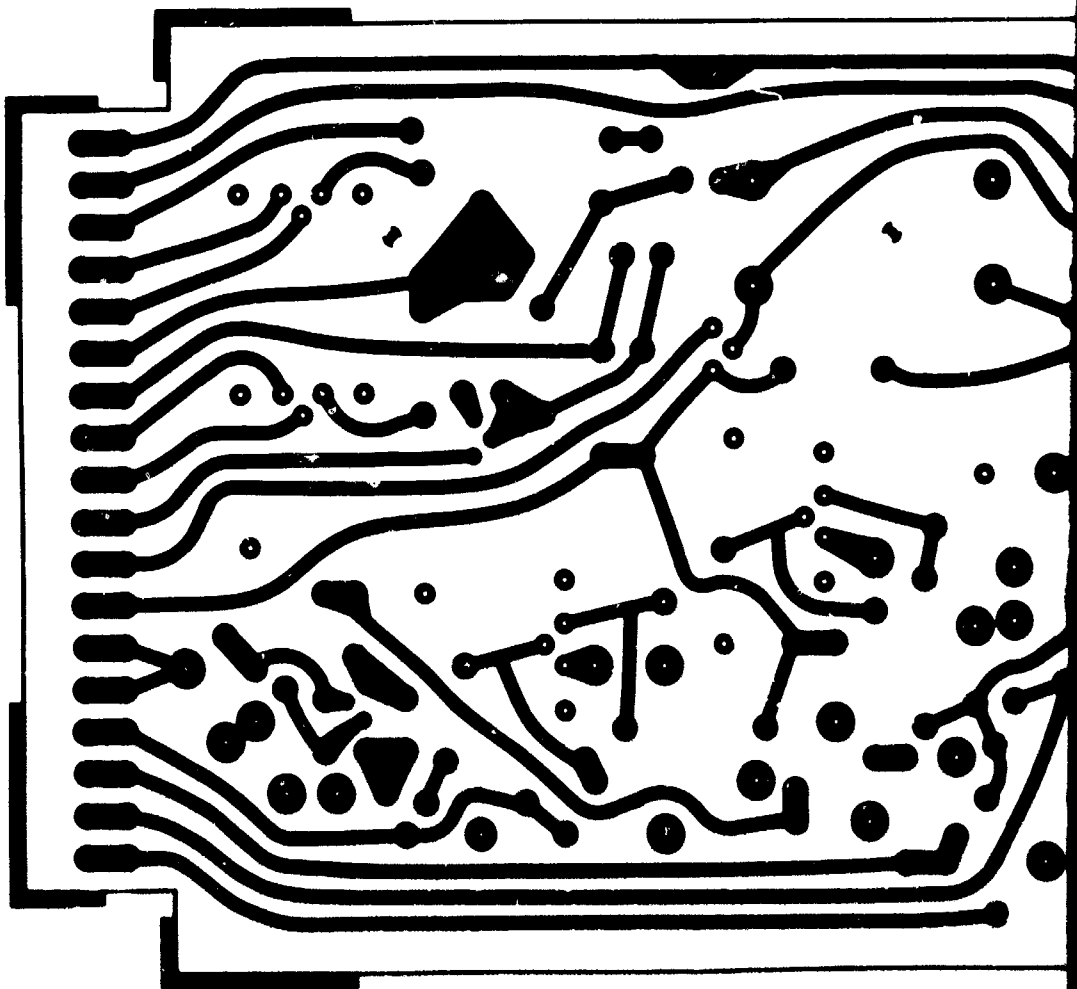

BACK
SEE SHEET 2 FOR OTHER SIDE

A

THE ORIGINAL MASTER ART (OR A REPRODUCTION PREPARED BY A METHOD WHICH WILL ASSURE DIMENSIONAL STABILITY) IS AN ACCURATE ENLARGED SCALE MASTER FOR PRODUCTION OF THE DEPICTED ITEM.

PRINTS OF THIS DRAWING ARE FOR REFERENCE ONLY.

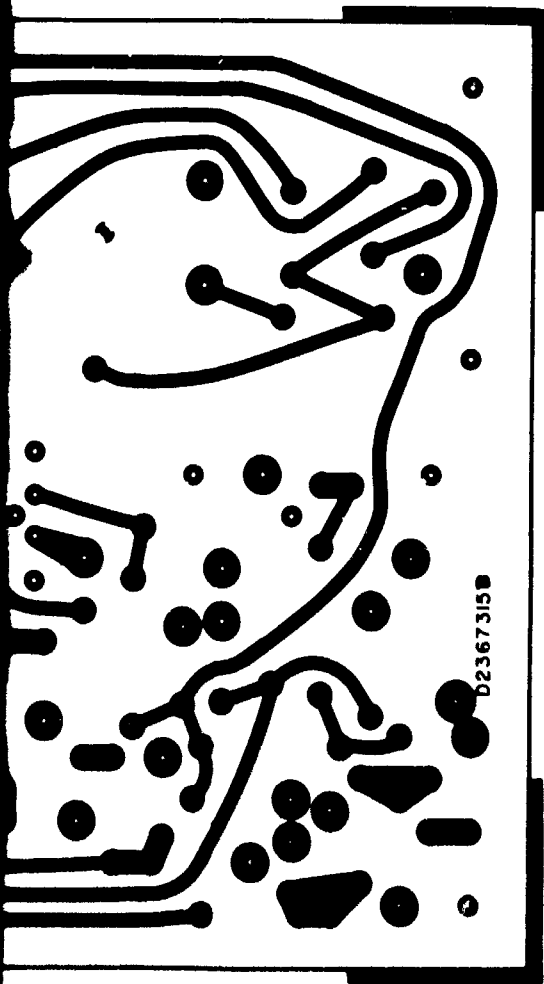
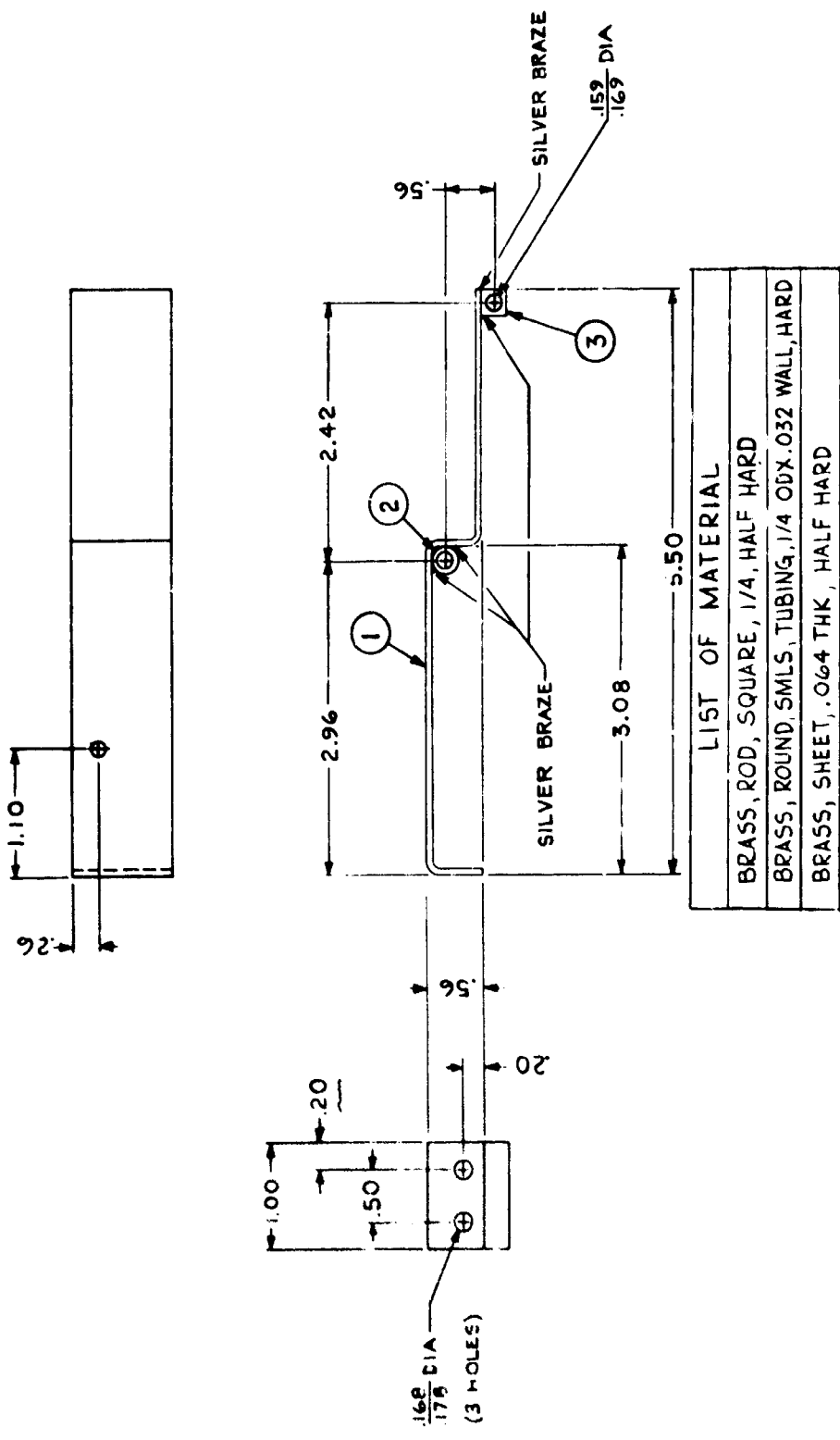

Figure A-98. Printed Wiring Board
(Master) (D2367315) (Sheet 3 of 3)

SIDE

A-101

β



| LIST OF MATERIAL | |
|--|--|
| BRASS, ROD, SQUARE, 1/4, HALF HARD | |
| BRASS, ROUND, SMLS, TUBING, 1/4 ODX, .032 WALL, HARD | |
| BRASS, SHEET, .064 THK, HALF HARD | |

NOTE:
ALL BEND RADII TO BE .06

A-102

Figure A-99. Bracket (C2367316)

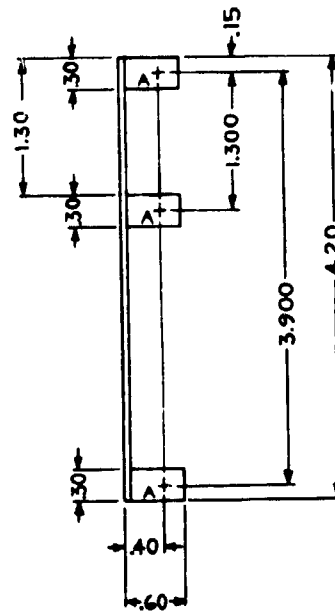
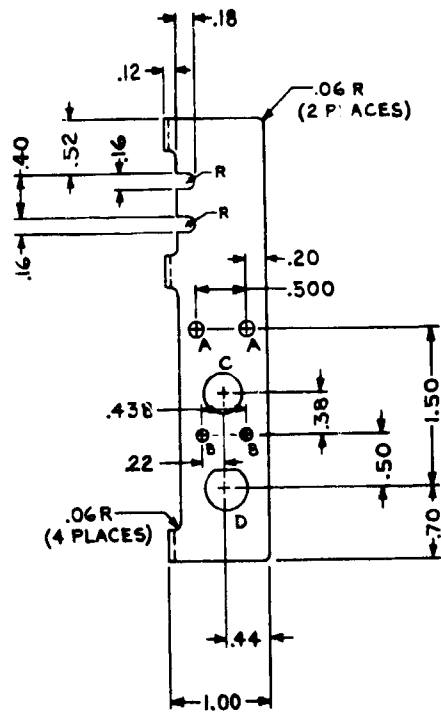

NOTE:
ALL BEND RADII TO BE .06

| HOLE | DESCRIPTION |
|------|---------------|
| A | .168-.178 DIA |
| B | .135-.145 DIA |
| C | .370-.380 DIA |
| D | DD-0440 |

| LIST OF MATERIAL |
|------------------------------------|
| BRASS, SHEET, 064 THK HALF HARD |

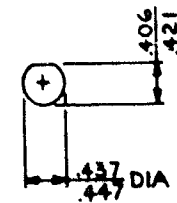

DD-0440

D

Figure A-100. Bracket (C2367317)

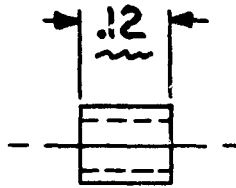

| |
|--|
| LIST OF MATERIAL |
| BRASS, ROUND, SMLS, TUBING, 3/16 OD X .032 WALL, HARD |

Figure A-101. Spacer (B2367318)

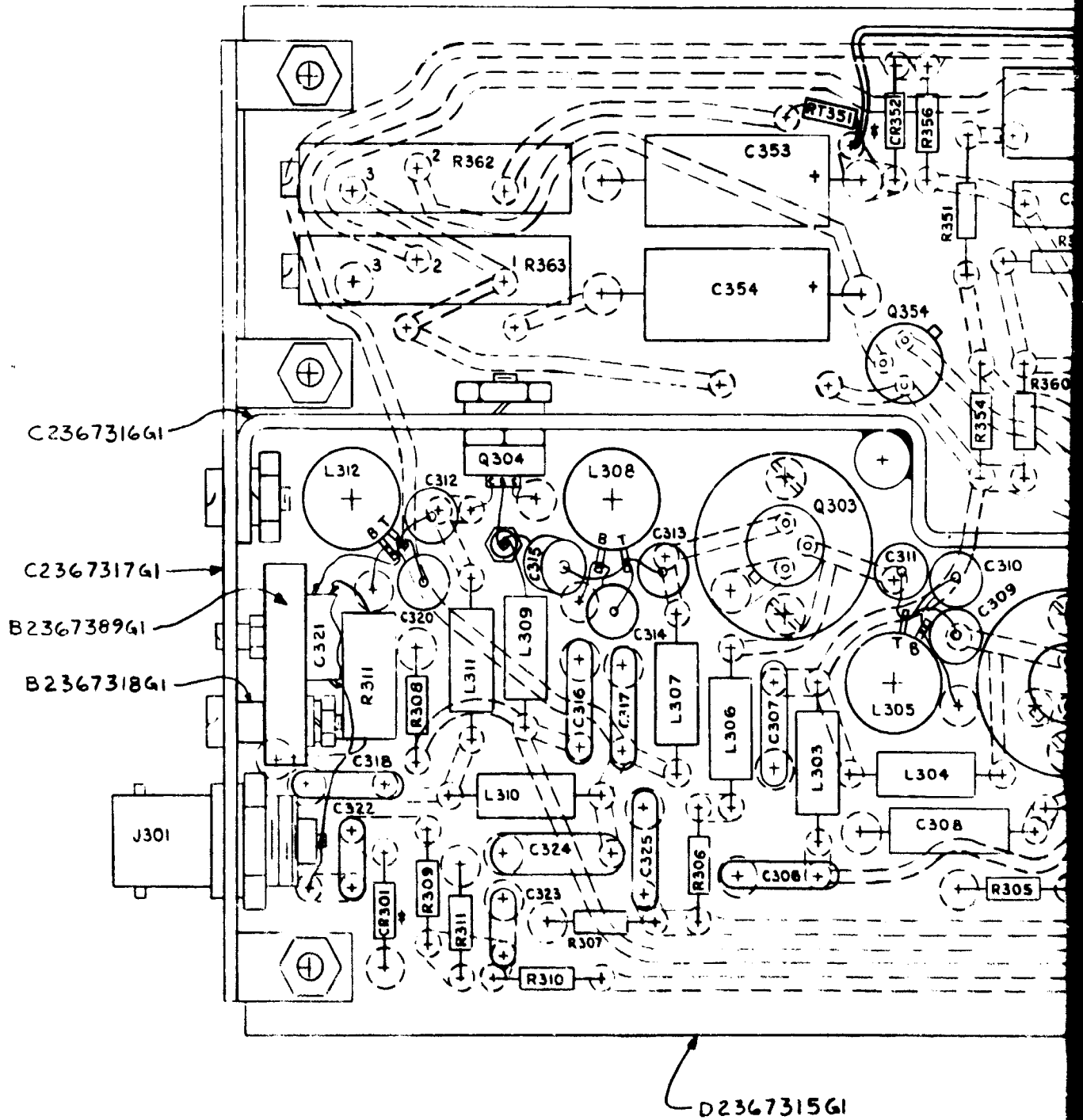

A

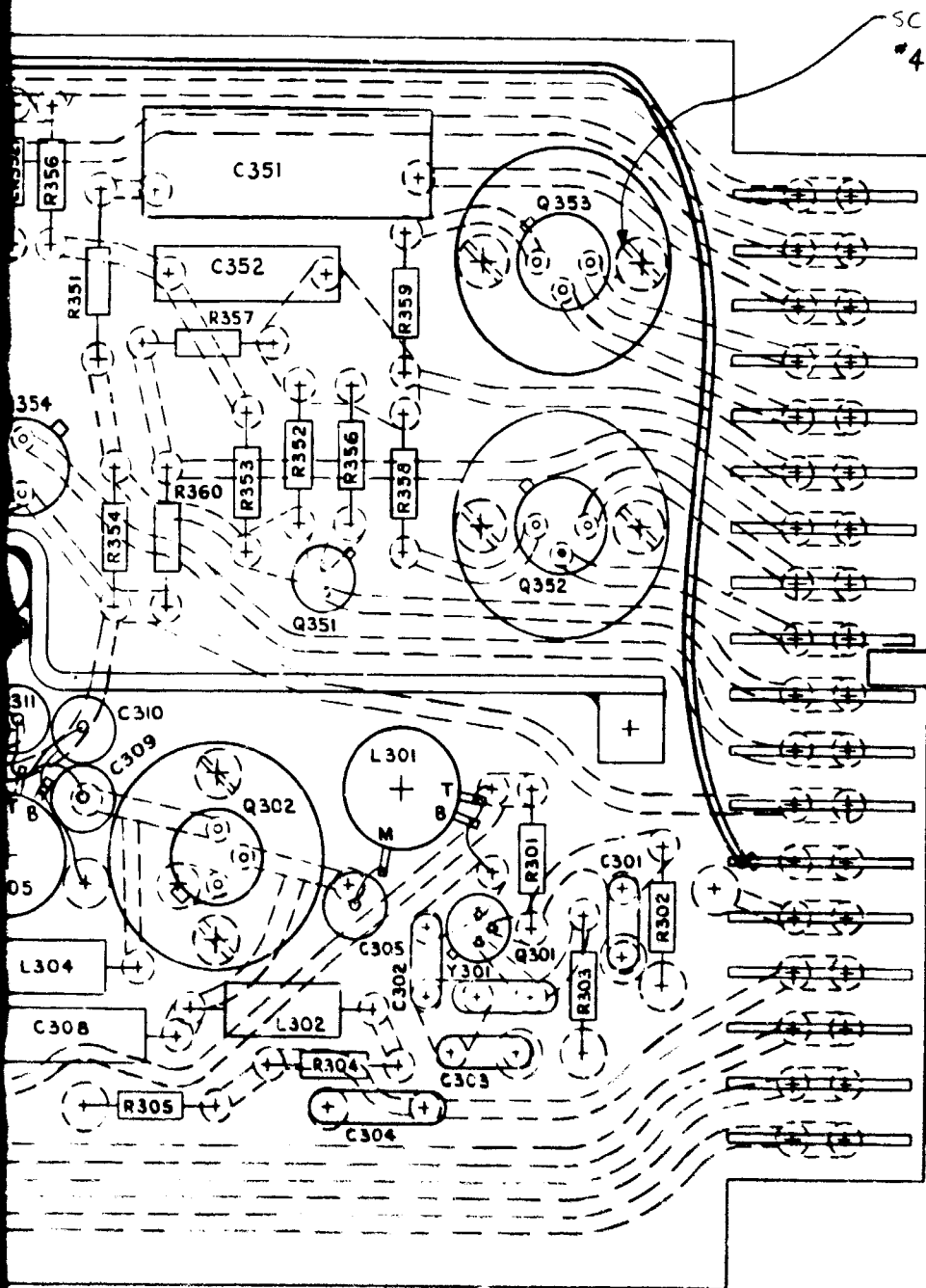

SCREW, MACH, BH SLOTTED NYLON,
 #4 (.112)-40 X .18 LG. (8 REQ'D)

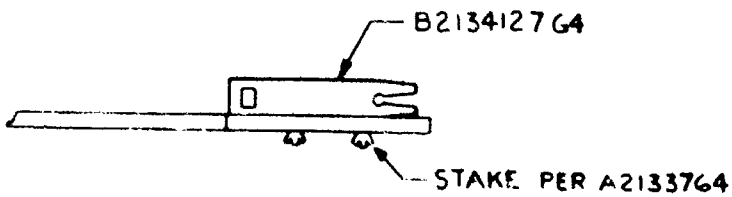
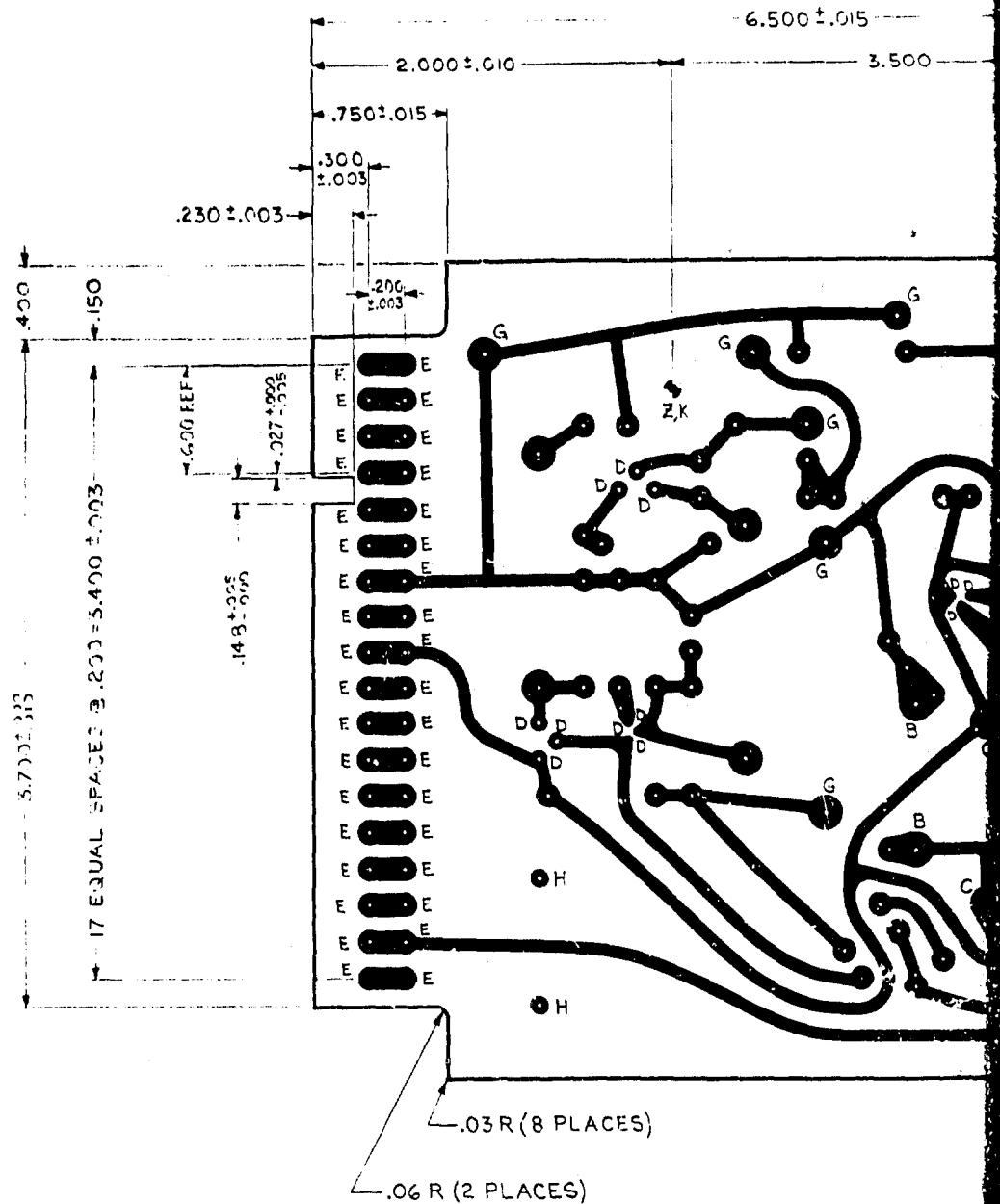

Figure A-102. Printed Wiring Board
 Assembly (D2367319)

B

A-105



NOTES:

1. UNLESS A DIMENSION OR TOLERANCE IS SPECIFICALLY STATED, HOLE CENTERS SHALL BE LOCATED AS FOLLOWS.
 - (A) FOR HAND INSERTION OF PARTS, WITHIN .008 OF THE TRUE .10 OR .025 COORDINATE GRID POSITION.
 - (B) FOR MACHINE INSERTION OF PARTS, WITHIN .002 OF THE TRUE .10 OR .025 COORDINATE GRID POSITION, AND, IF TOOL HOLE CENTER REFERENCE POINTS OR THE BOARD REFERENCE EDGES (WHICHEVER IS APPLICABLE) ARE OFFSET FROM THE TRUE COORDINATE GRID, THIS OFFSET SHALL BE UNIFORM WITHIN ± .001 FOR ANY GIVEN LOT OF BOARDS.
2. EACH PRODUCTION ORDER SHALL STATE THE HOLE POSITION TOLERANCE APPLICABLE FOR THAT SPECIFIC MANUFACTURING LOT.
3. TRIM BOARD ALONG INSIDE EDGE OF TRIM LINE. MAINTAIN DIMENSIONS WITHIN SPECIFIED LIMITS. AFTER TRIMMING REMOVE ALL EXCESS COPPER ALONG THE EDGE.
4. FOR MASTER ART SEE SHEET 2 OF THIS DRAWING. FABRICATED PRINTED WIRING PATTERN SHALL MEET THE REQUIREMENTS OF SPECIFICATION

5. MATERIAL: GLASS FABRIC BOARD SHEET, LAMINATED .062 THK, 2 OZ COPPER, TYPE DESIGNATION SPECIFICATION MIL-P-13949C
6. AFTER ETCHING AND DRILLING .003 THICK MINIMUM TO A
7. AFTER SHEARING, FINE SAND

A

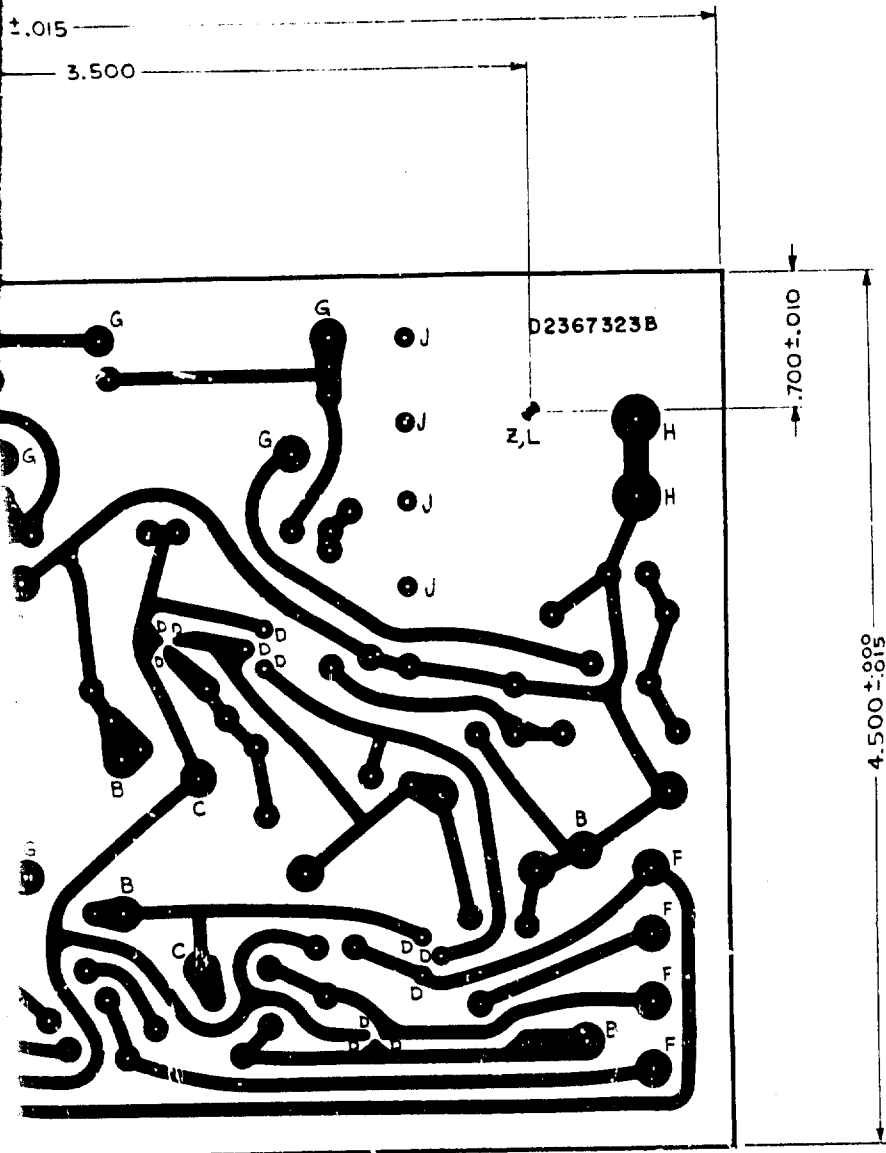

| HOLE | DESCRIPTION |
|------|---------------|
| ** A | .047-.055 DIA |
| B | .053-.061 DIA |
| C | .068-.076 DIA |
| D | .033-.040 DIA |
| E | .048-.052 DIA |
| F | .092-.096 DIA |
| G | .062-.070 DIA |
| H | .168-.178 DIA |
| J | .125-.132 DIA |
| Z | .122-.131 DIA |
| Z | .182-.191 DIA |

Z USE FOR TOOL HOLES
 ** ALL HOLES NOT MARKED ARE "A" HOLES

GLASS FABRIC BASE, EPOXY PLASTIC
 LAMINATED .062 THK, SINGLE COPPER CLAD WITH
 99.9% COPPER, TYPE DESIGNATION GF .062 C²/% PER
 MIL-P-13949C.
 AFTER SOLDERING AND DRILLING, APPLY SOLDER COAT
 OF MINIMUM .001 THK TO ALL COPPER SURFACES.
 AFTER SOLDERING, FINE SAND ALL EDGES OF BOARD.

Figure A-103. Printed Wiring Board
 (Drilled) (D2367323) (Sheet 1 of 2)

A-106

B

REDUCE TO
9.000 ± .010

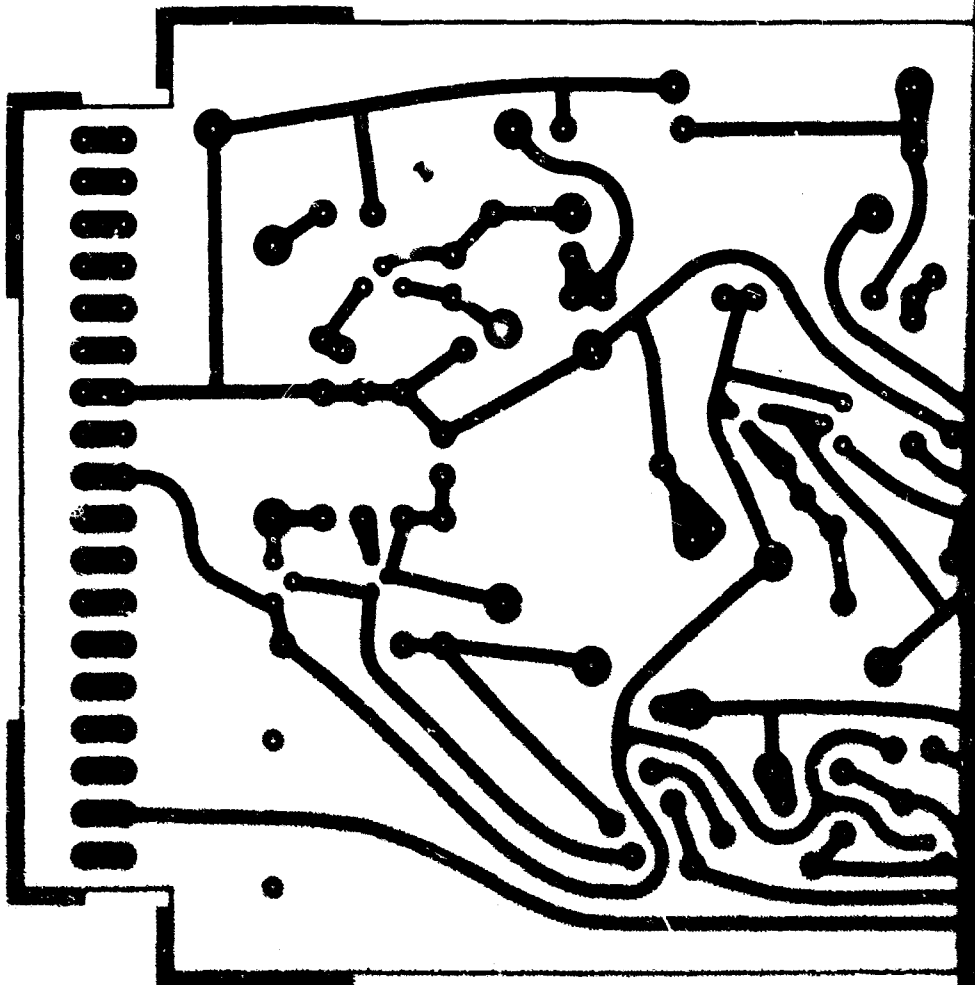

A

THE ORIGINAL MASTER ART (OR A REPRODUCTION PREPARED BY A METHOD WHICH WILL ASSURE DIMENSIONAL STABILITY) IS AN ACCURATE ENLARGED SCALE MASTER FOR PRODUCTION OF THE DEPICTED ITEM.

PRINTS OF THIS DRAWING ARE FOR REFERENCE ONLY.

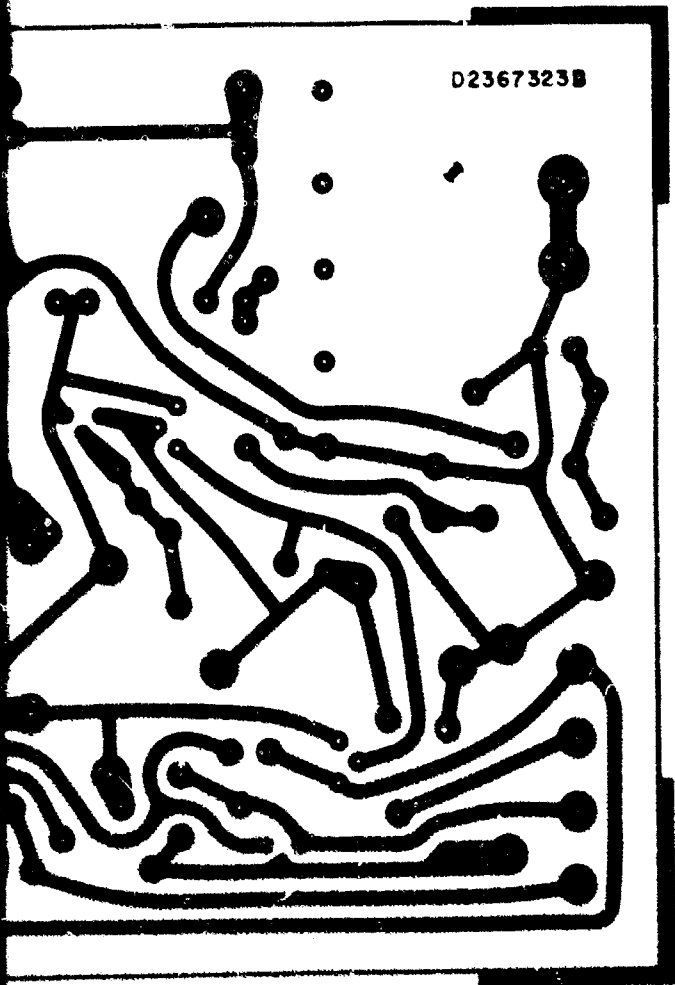
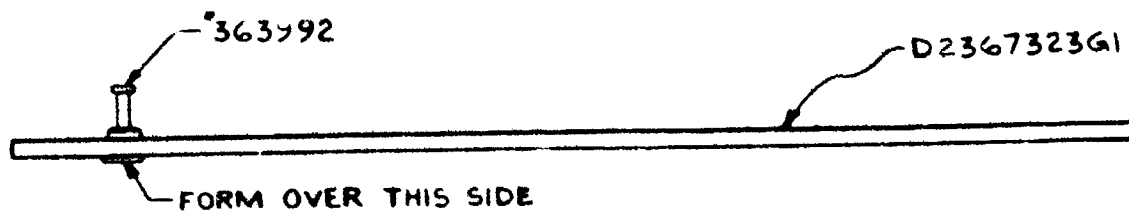
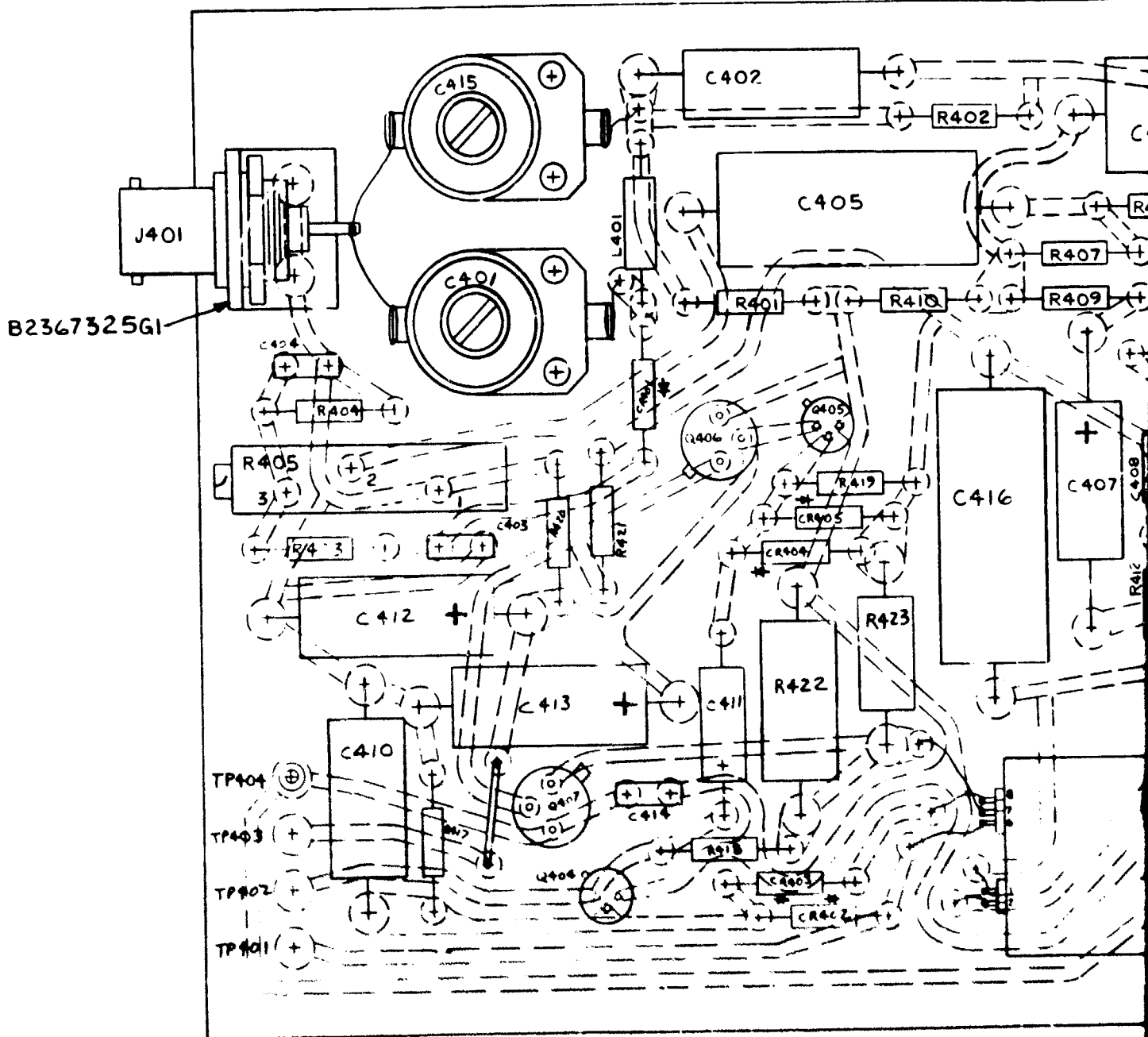

Figure A-103. Printed Wiring Board
(Master) (D2367323) (Sheet 2 of 2)

A-107

B



A

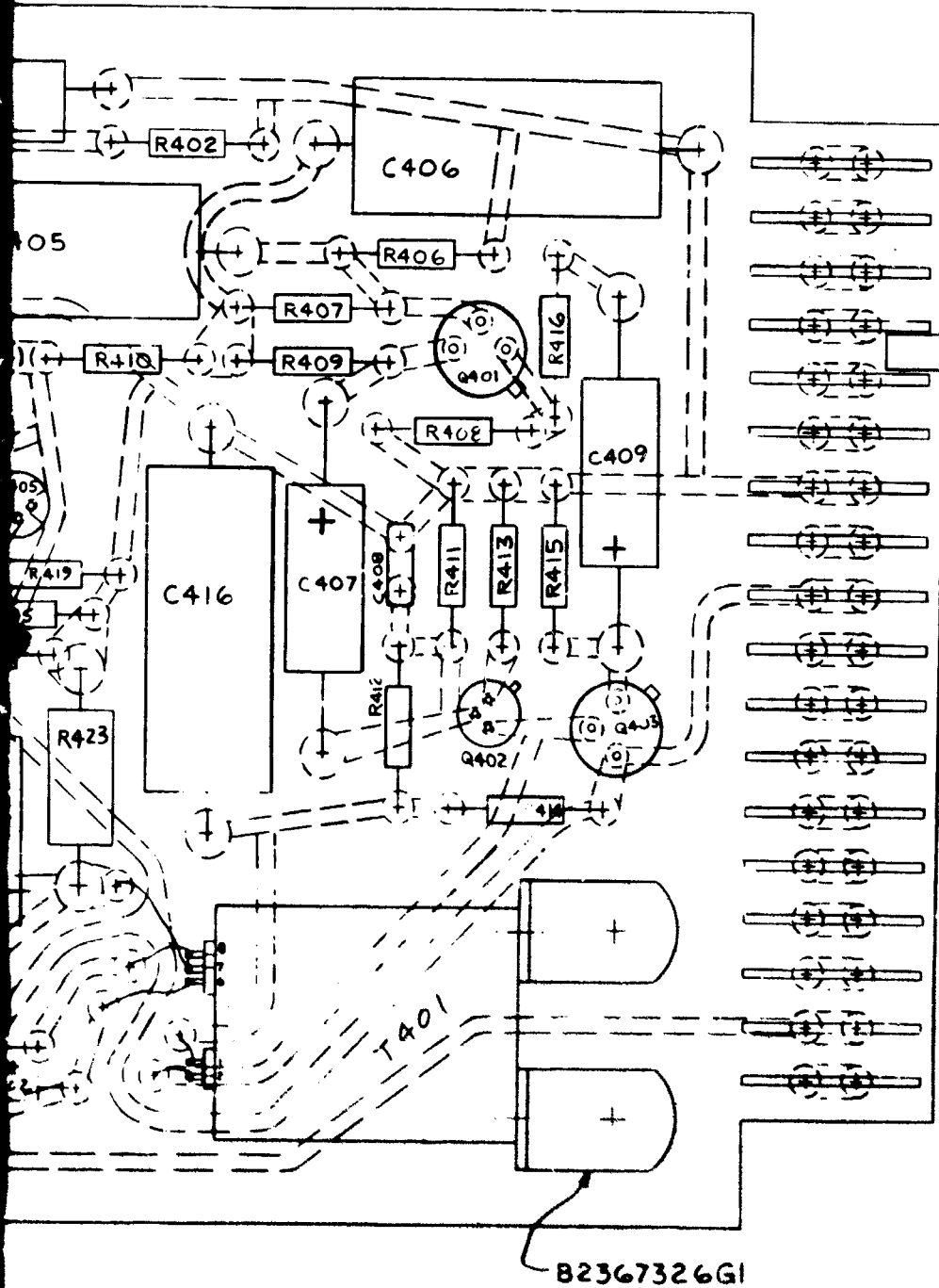
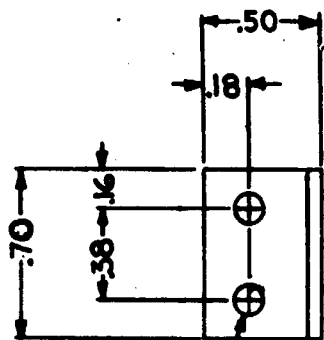

Figure A-104. Printed Wiring Board Assembly (D2367324)

A-108

B



$\frac{.168}{.178}$ DIA (2 HOLES)

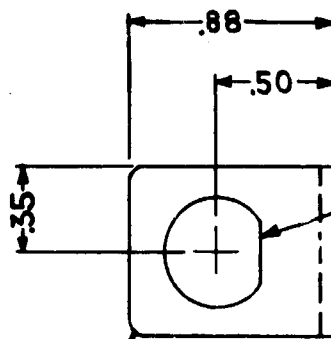

DD-0440

.06 R (2 PLACES)

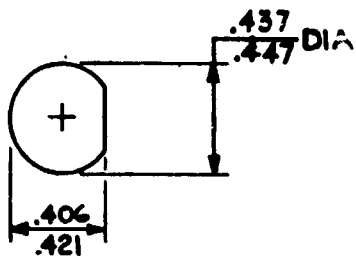

DD-0440

| LIST OF MATERIAL |
|--|
| BRASS, SHEET, .064 THK, HALF HARD, BEST COMMERCIAL QUALITY |

NOTE:
BEND RADIUS TO BE .06

Figure A-105. Bracket, Connector (B2367325)

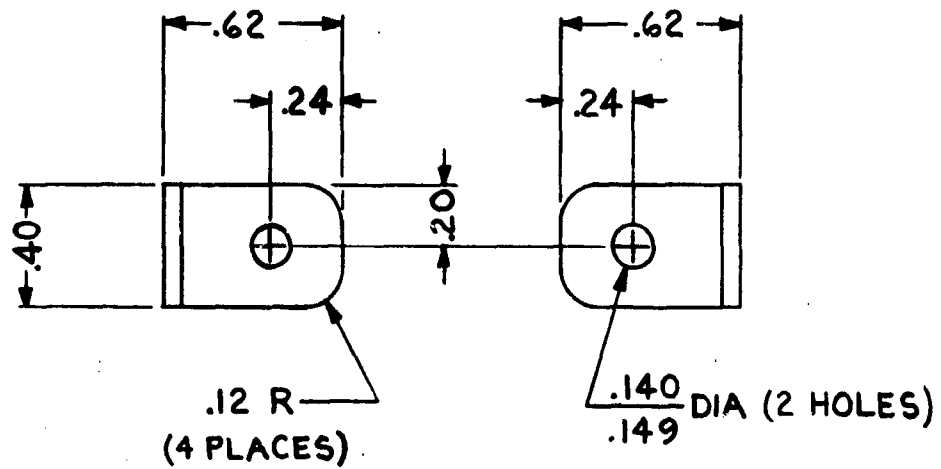

NOTE:

BEND RADIUS TO BE .06

| LIST OF MATERIAL |
|---|
| BRASS, SHEET, .064 THK, HALF HARD, BEST COMMERCIAL QUALITY. |

Figure A-106. Bracket, Transformer (B2367326)

- NOTES:
1. UNLESS OTHERWISE SPECIFIED:
RESISTANCE VALUES ARE IN OHMS.
 2. TERMINAL NUMBERING FOR S1101 IS FOR REFERENCE ONLY.
RELATIVE LOCATION OF TERMINALS ARE SHOWN IN DIAGRAM
AT LEFT OF NOTES SWITCH IS SHOWN VIEWED FROM FRONT
WITH KNOB IN EXTREME CCW POSITION.

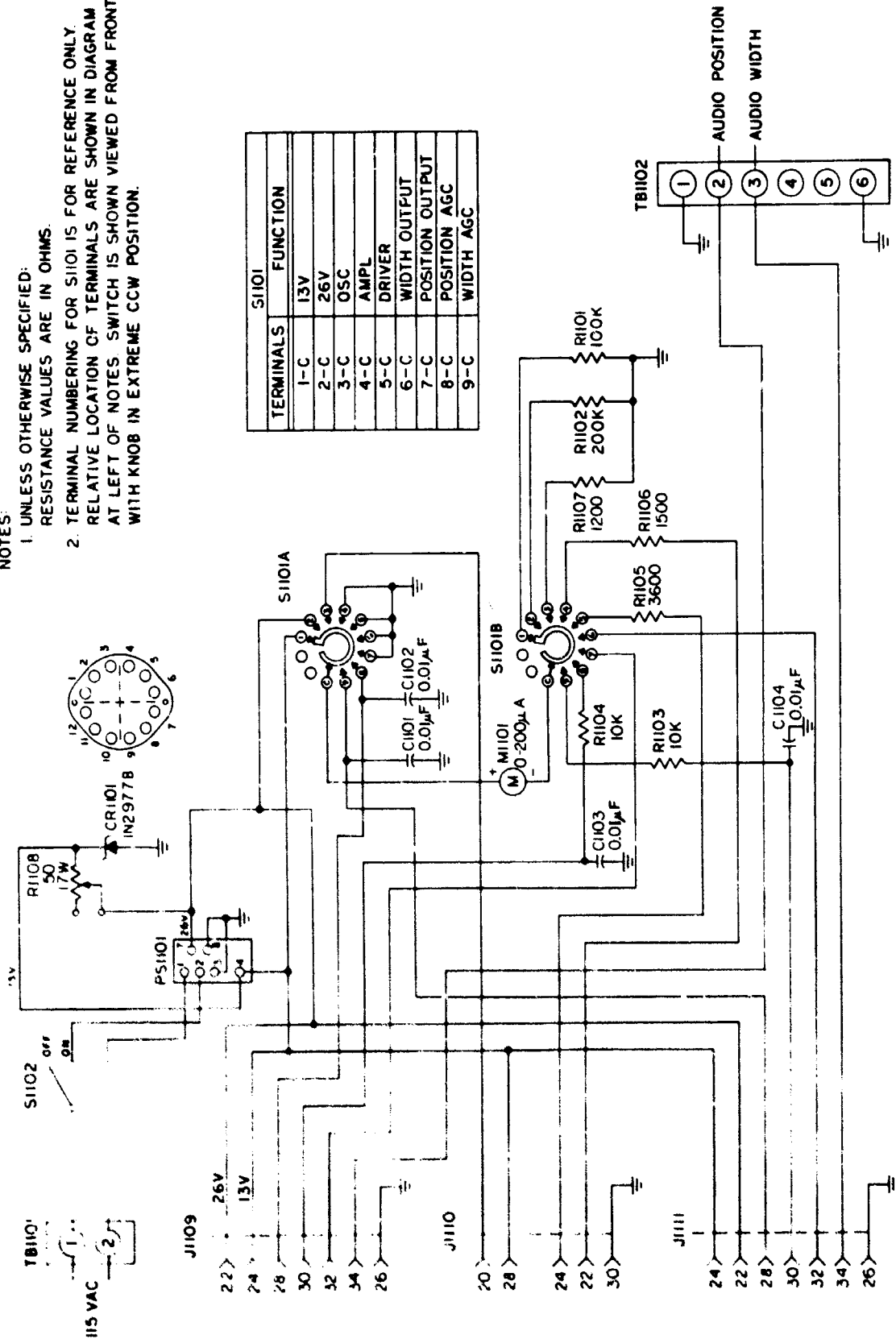

| TERMINALS | S1101 | FUNCTION |
|-----------|-----------------|----------|
| 1-C | 13V | |
| 2-C | 26V | |
| 3-C | OSC | |
| 4-C | AMPL | |
| 5-C | DRIVER | |
| 6-C | WIDTH OUTPUT | |
| 7-C | POSITION OUTPUT | |
| 8-C | POSITION AGC | |
| 9-C | WIDTH AGC | |

Figure A-107. Schematic Diagram, Intra Cabinet Wiring GS Field Detector (F2367332)

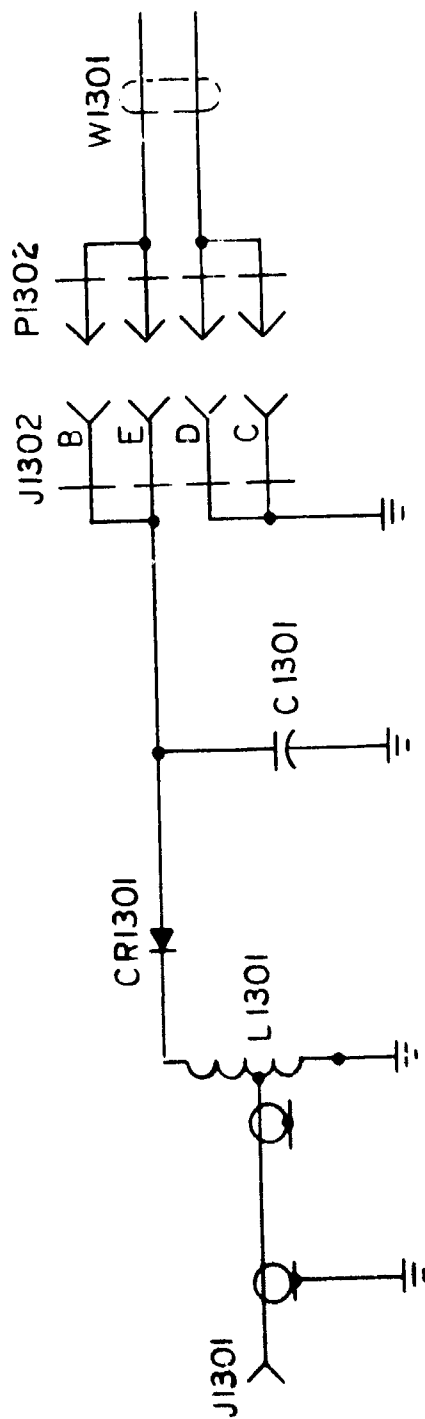
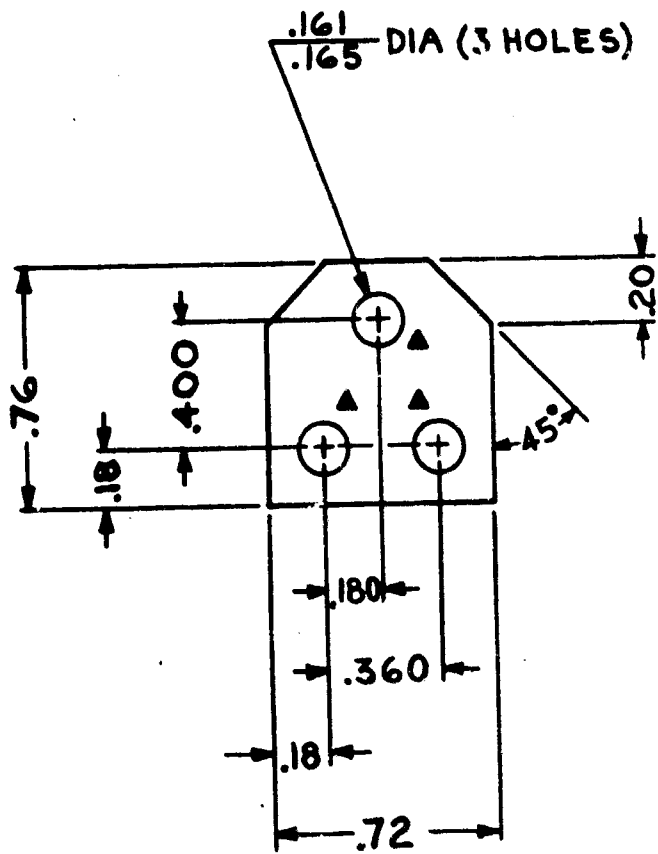

Figure A-108. Schematic Diagram, RF Level Detector GS Transmitter (C2367333)



NOTE:

HOLES MARKED ▲ ARE
RIVET HOLES WHICH
MUST MATCH PART
D2205194G1

| |
|-------------------|
| LIST OF MATERIAL |
| ALUMINUM, ALLOY, |
| SHEET, .090 THK., |
| TYPE 5052-H32 |

Figure A-109. Shim (B2367335)

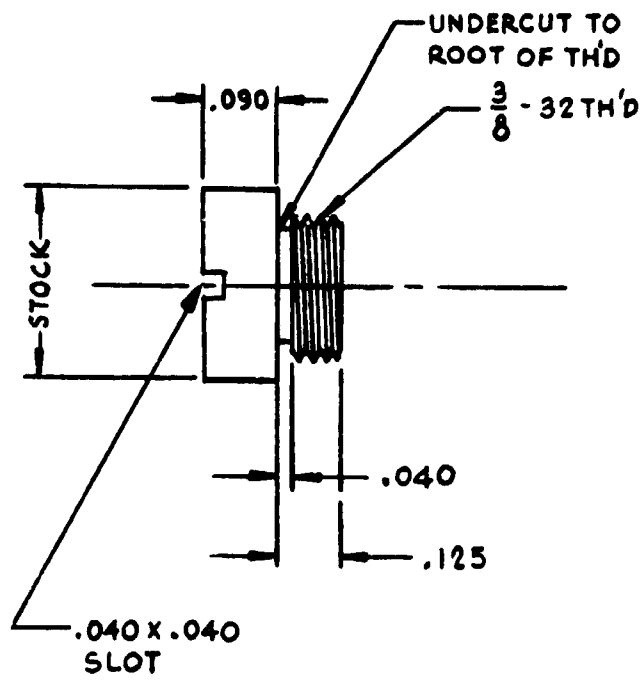

| LIST OF MATERIAL |
|--|
| BRASS $\frac{7}{16}$ DIA. ROD, FREE TURNING |

Figure A-110. Plug, Elbow (B2367348)

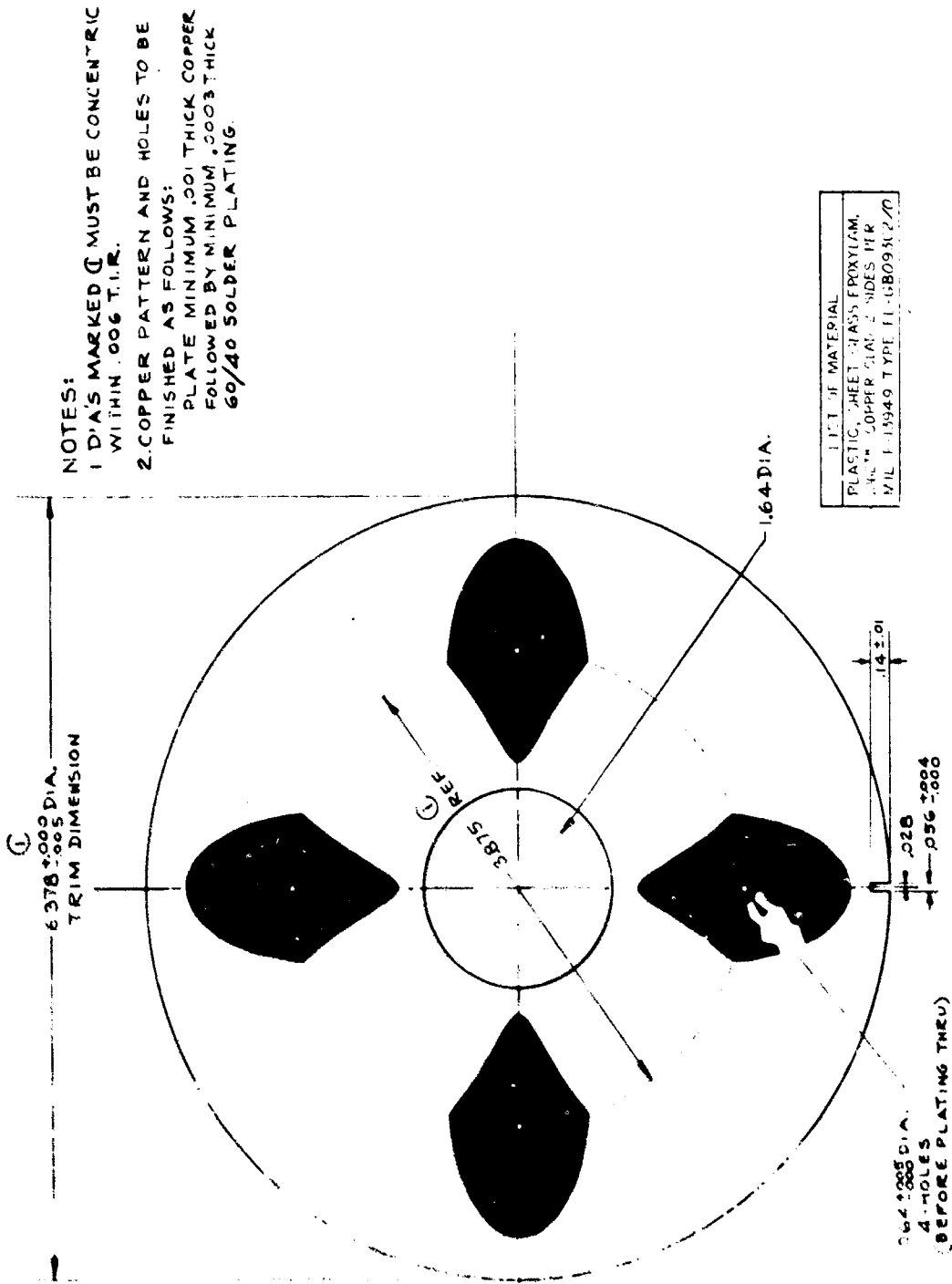
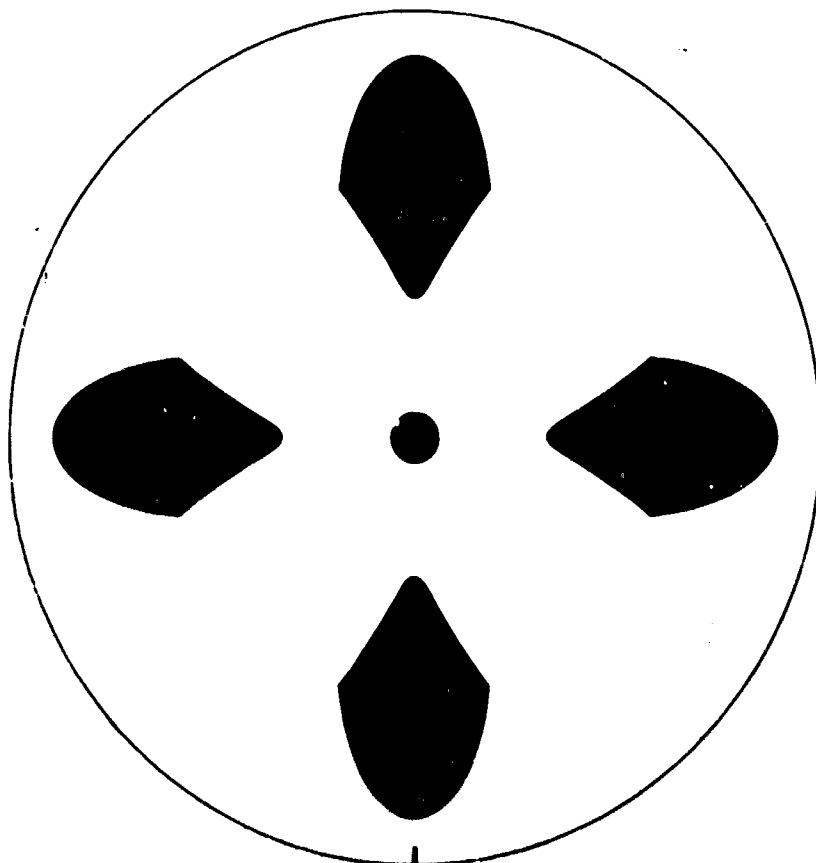

Figure A-111. Plate, Pickup 150~ (Drilled) (D2367350)(Sheet 1 of 3)

REDUCE TO 8.000±010



D2367350A

FRONT - SEE SHEET 3 FOR OTHER SIDE

THE ORIGINAL DRAWING AND ALL REPRODUCTIONS THEREOF BY A
DIFFERENT METHOD WILL BECOME UNREPRODUCIBLE QUALITY IF AN
APPROPRIATE QUALITY SCALE IS NOT USED FOR PRODUCTION OF THE
REPRODUCED FILE.
PARTS OF THE DRAWING ARE FOR REFERENCE ONLY.

Figure A-111. Plate, Pickup 150 (Master) (D2367350) (Sheet 2 of 3)

REDUCE TO 8.00 ± 0.01

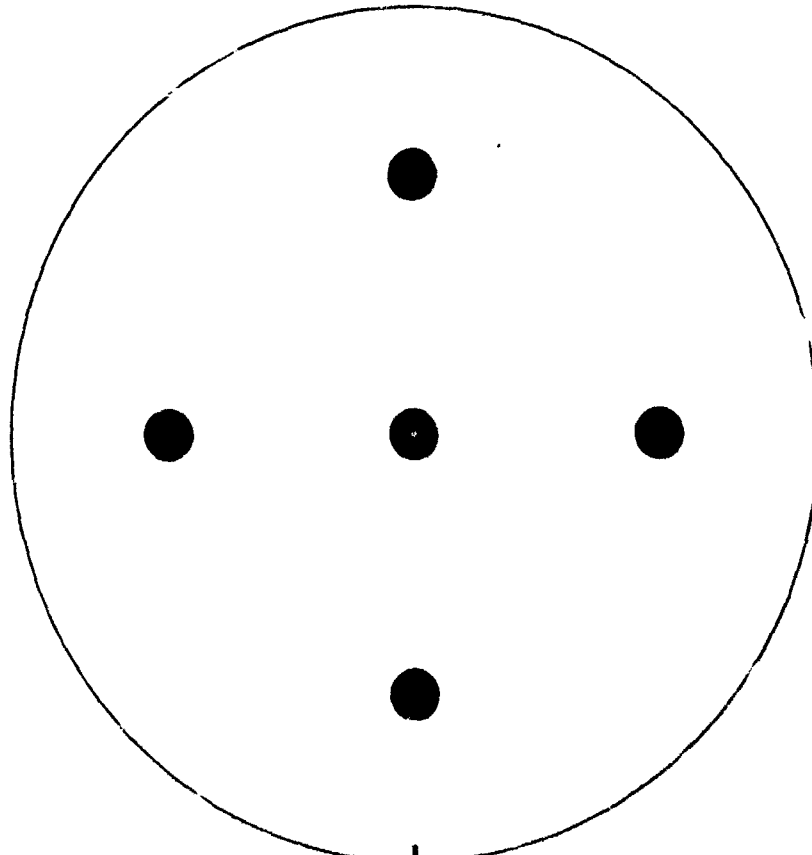

D2367350A

BACK-SEE SHEET 2 FOR OTHER SIDE

THE ABOVE DRAWING IS A REPRESENTATION OF A
DESIGN WHICH WILL BE MADE TO ORDER. IT IS
NECESSARY TO CHECK THE DIMENSIONS OF THE
PARTS WITH THE MANUFACTURER.
FIGURE OF THIS DRAWING IS FOR INFORMATION ONLY.

Figure A-111. Plate, Pickup 150 (Master) (D2367350) (Sheet 3 of 3)

A-117

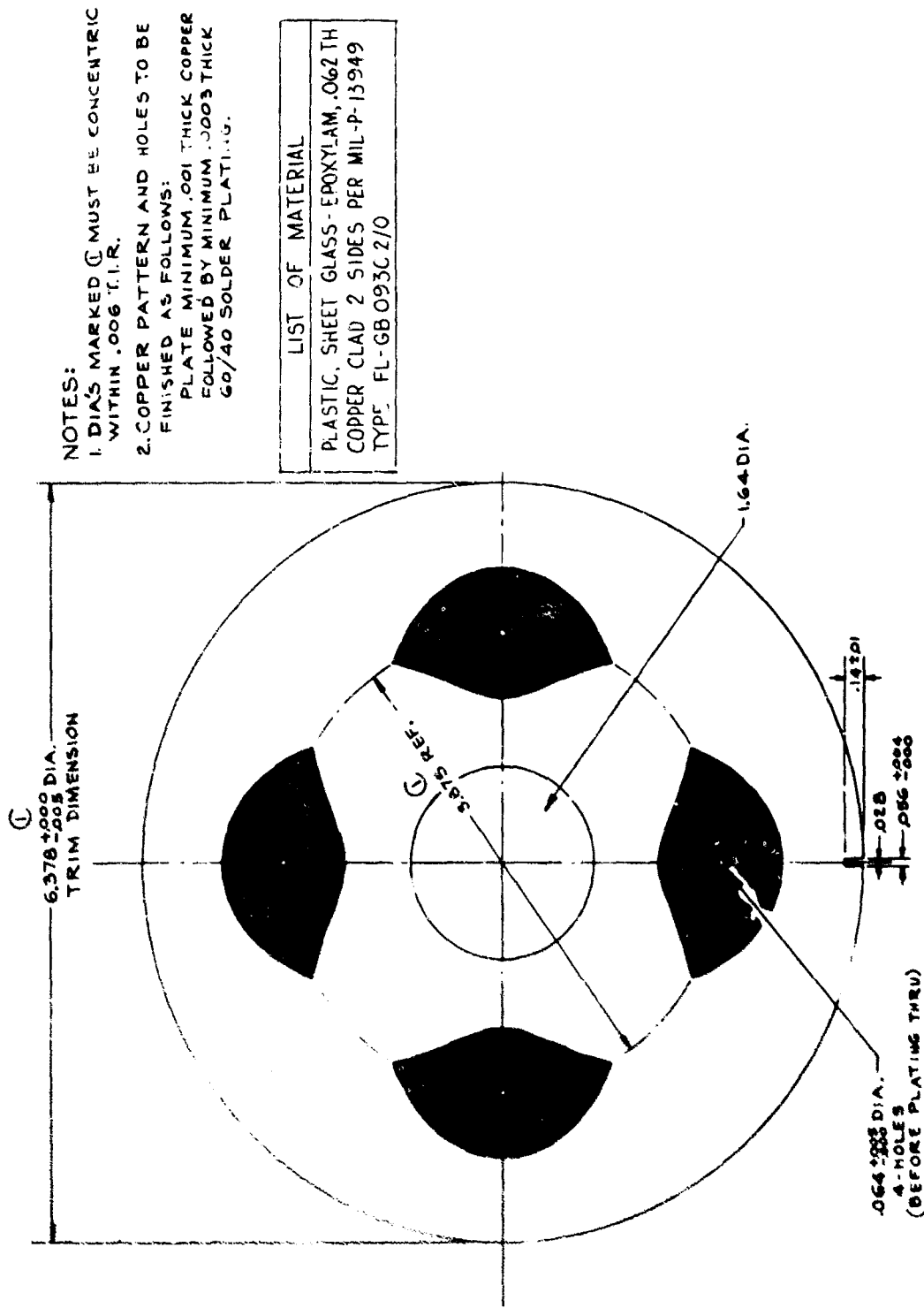

NOTES:
 1. DIAS MARKED C MUST BE CONCENTRIC WITHIN .006 T.I.R.
 2. COPPER PATTERN AND HOLES TO BE FINISHED AS FOLLOWS:
 PLATE MINIMUM .001 THICK COPPER FOLLOWED BY MINIMUM .0003 THICK 60/40 SOLDER PLATING.

| LIST OF MATERIAL |
|--|
| PLASTIC, SHEET GLASS - EPOXYLAM, .062 TH |
| COPPER CLAD 2 SIDES PER MIL-P-13949 |
| TYPE: FL-GB 093C2/0 |

A-118

Figure A-112. Plate, Pickup 90 (Drilled) (D2367351) (Sheet 1 of 3)

REDUCE TO 8.000 ± 0.010

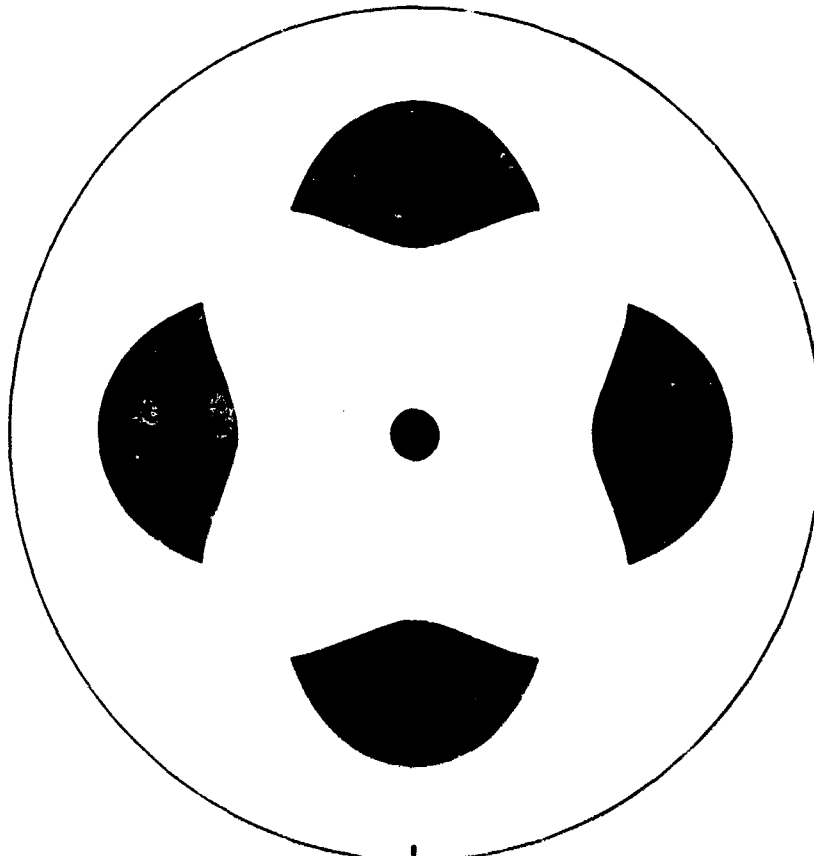

D2367351A

THIS DRAWING, UNLESS NOTED OTHERWISE, IS A REPRODUCTION OF A
DRAWING WHICH WAS MADE IN ACCORDANCE WITH THE
STANDARD DRAWING PRACTICES FOR PRODUCTION OF THE
DRAWING FILE.
PARTS OF THIS DRAWING ARE FOR REFERENCE ONLY.

FRONT - SEE SHEET 3 FOR OTHER SIDE

Figure A-112. Plate, Pickup, 90° (Master)(D2367351)(Sheet 2 of 3)

A-119

REDUCE TO $8.000 \pm .010$

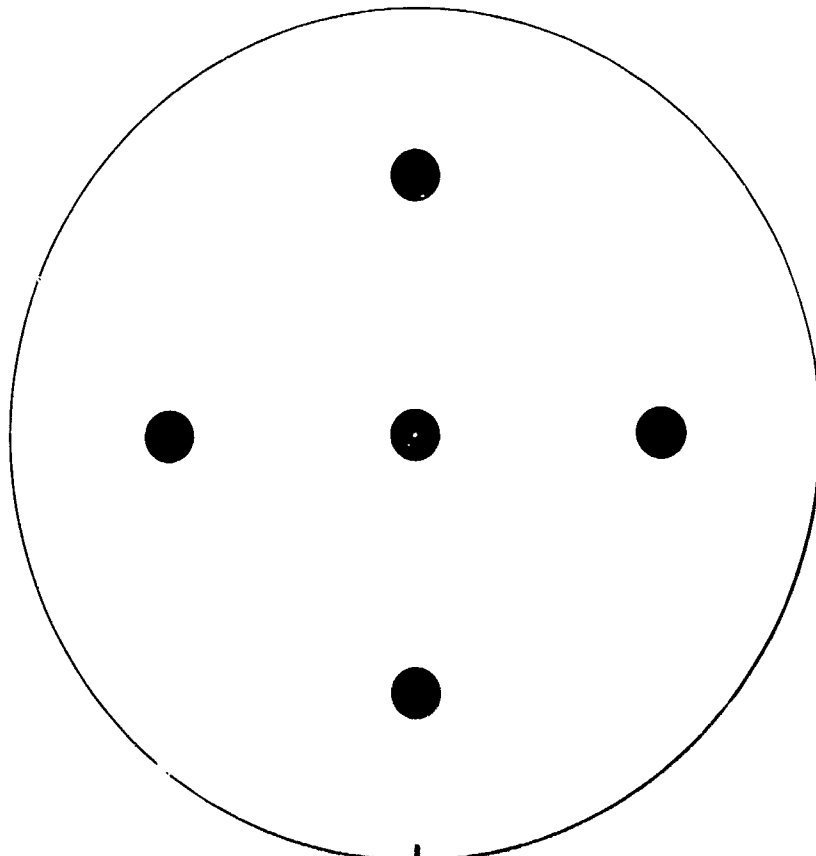

D2367351 A

BACK-SEE SHEET 2 FOR OTHER SIDE

THE GENERAL APPEARANCE OF ANY REPRESENTATION PROVIDED OF A
METHOD SHALL BE SUCH THAT THE GENERAL APPEARANCE OF AN
EXACTLY SIMILAR MODEL SHOULD BE THE RESULT OF THE
METHOD USED.

Figure A-112. Plate, Pickup, 90° (Master) (D2367351) (Sheet 3 of 3)

A-120

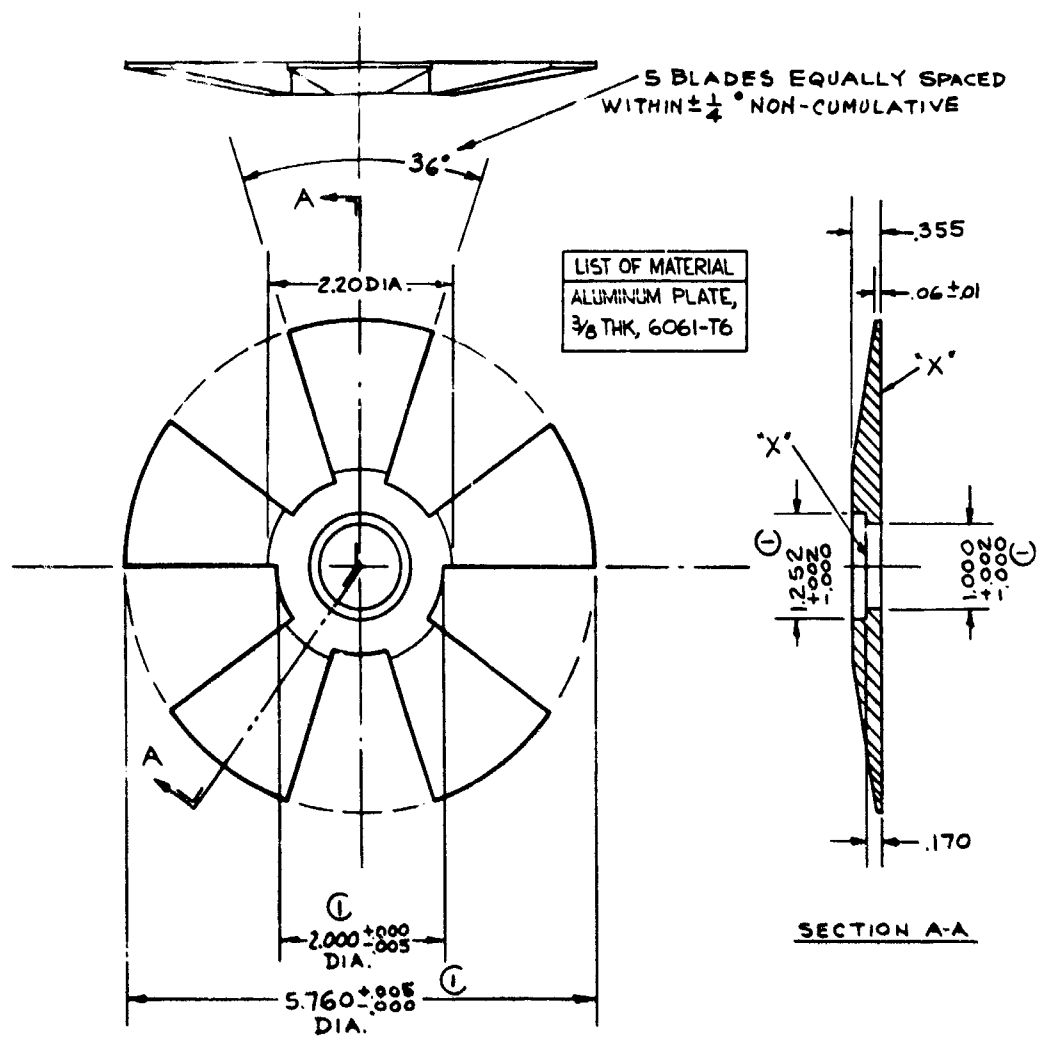

NOTES:
1. DIAS MARKED (C) MUST BE CONCENTRIC WITHIN .004 T.I.R.
2. SURFACES MARKED 'X' MUST BE PARALLEL AND FLAT WITH .004 T.I.R.

Figure A-113. Rotor, 150 ~ (C2367352)

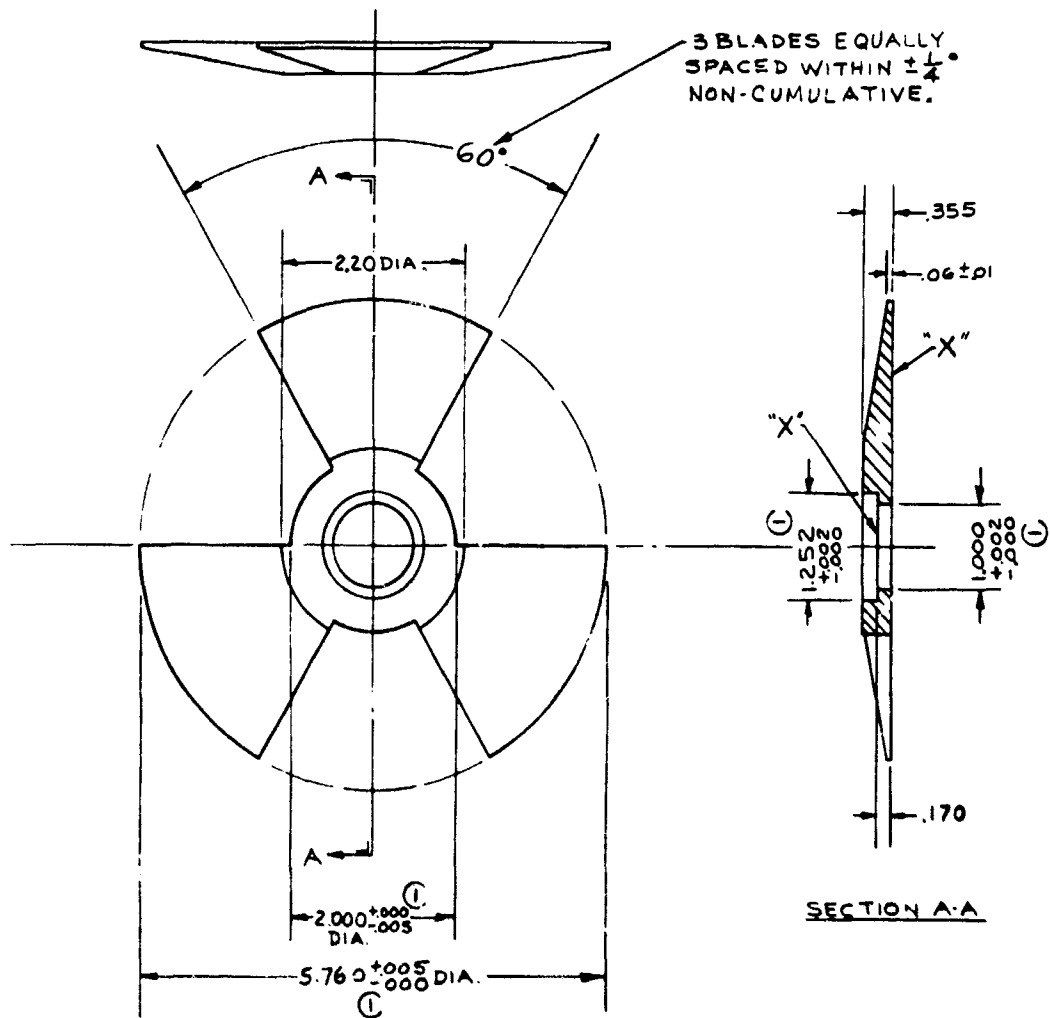

NOTES:
 1. DIA'S MARKED (1) MUST BE CONCENTRIC WITHIN .004 T.I.R.
 2. SURFACES MARKED "X" MUST BE PARALLEL AND FLAT WITHIN .004 T. R.

| |
|------------------|
| LIST OF MATERIAL |
| ALUMINUM PLATE, |
| 3/8 THK, 6061-T6 |

Figure A-114. Rotor, 90 ~ (C2367353)

LIST OF MATERIAL
BRASS ROD, 1/2 D/A.-
FREE TURNING

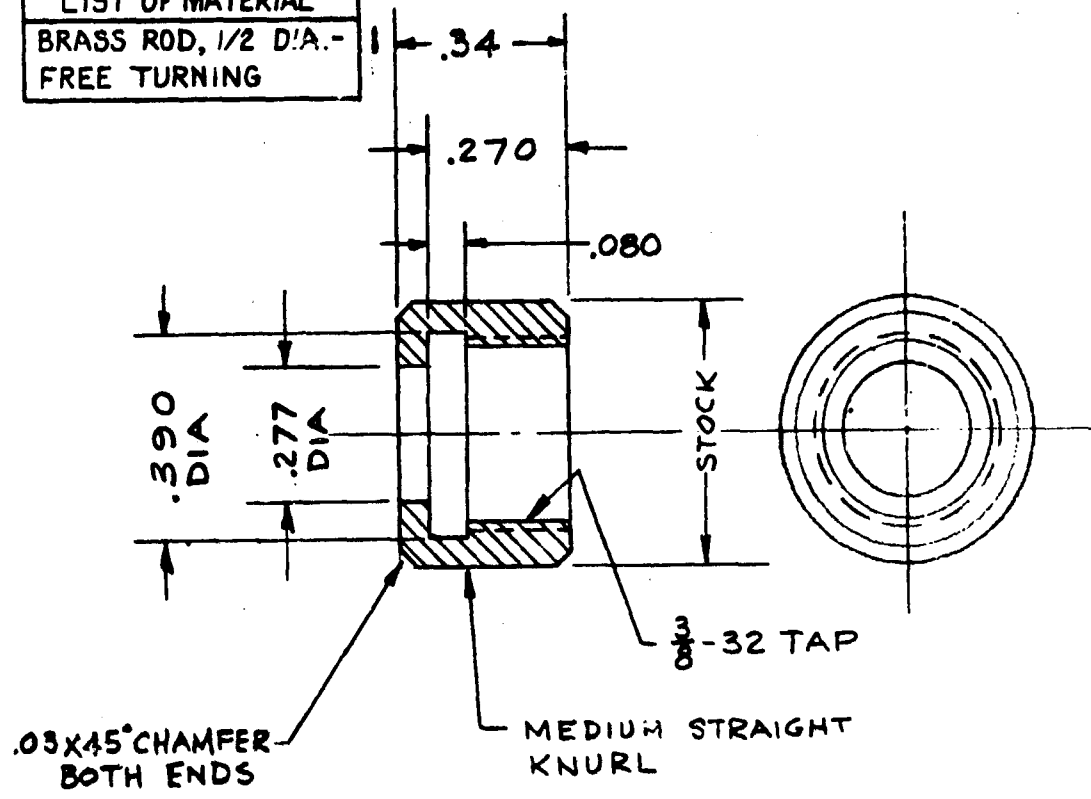
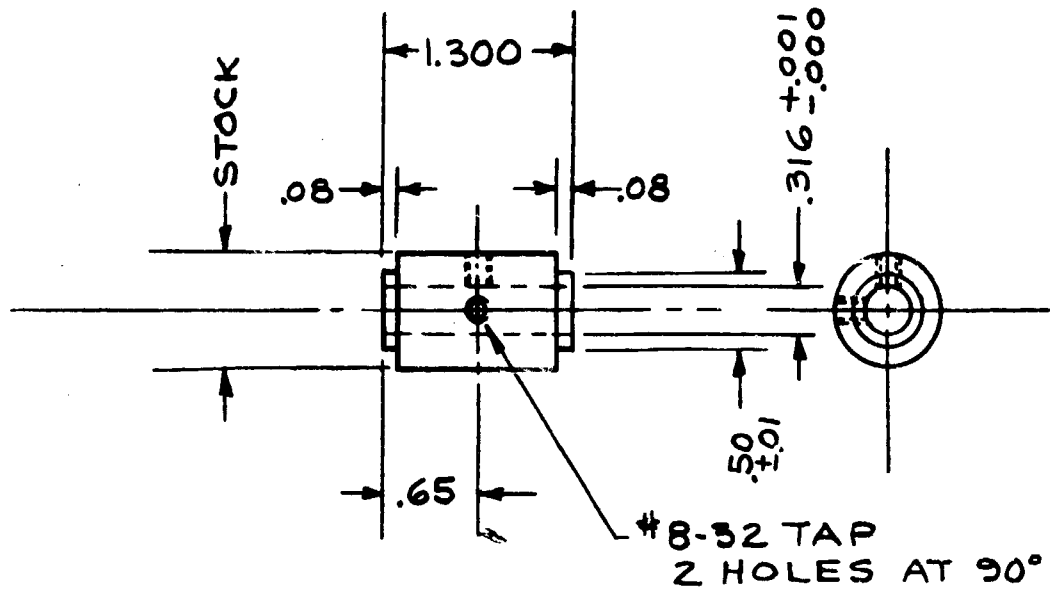

Figure A-115. Clamp, Tuning (B2367354)



| |
|---|
| LIST OF MATERIAL |
| STAINLESS STEEL ROD, $\frac{3}{16}$ DIA., TYPE 303 |

Figure A-116. Spacer, Bearing (B2367355)

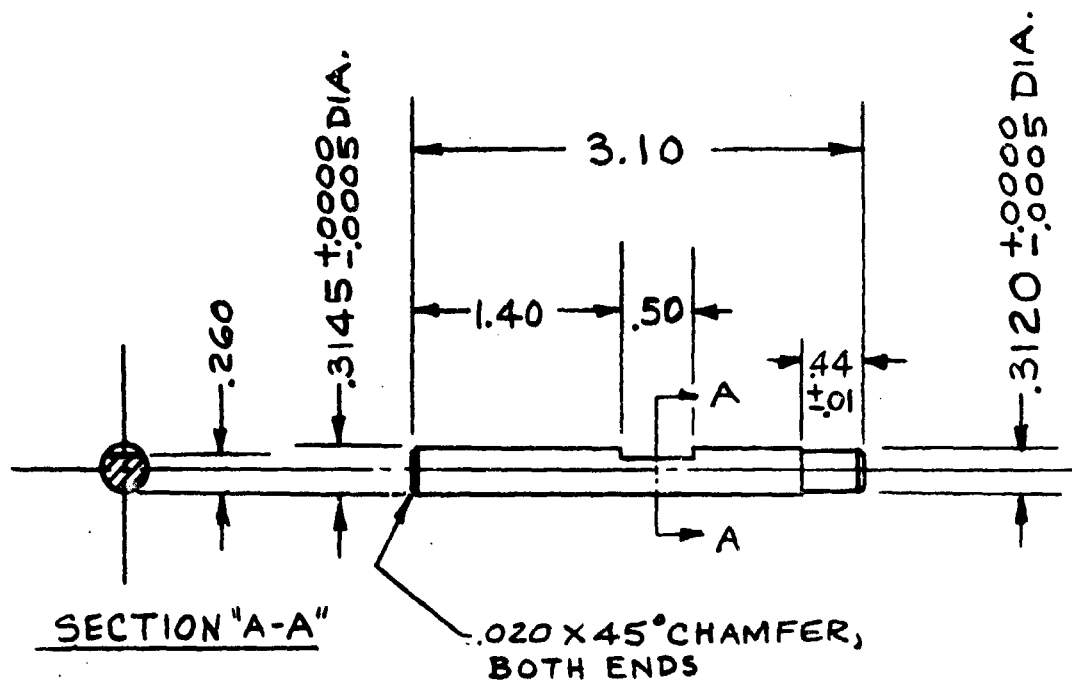
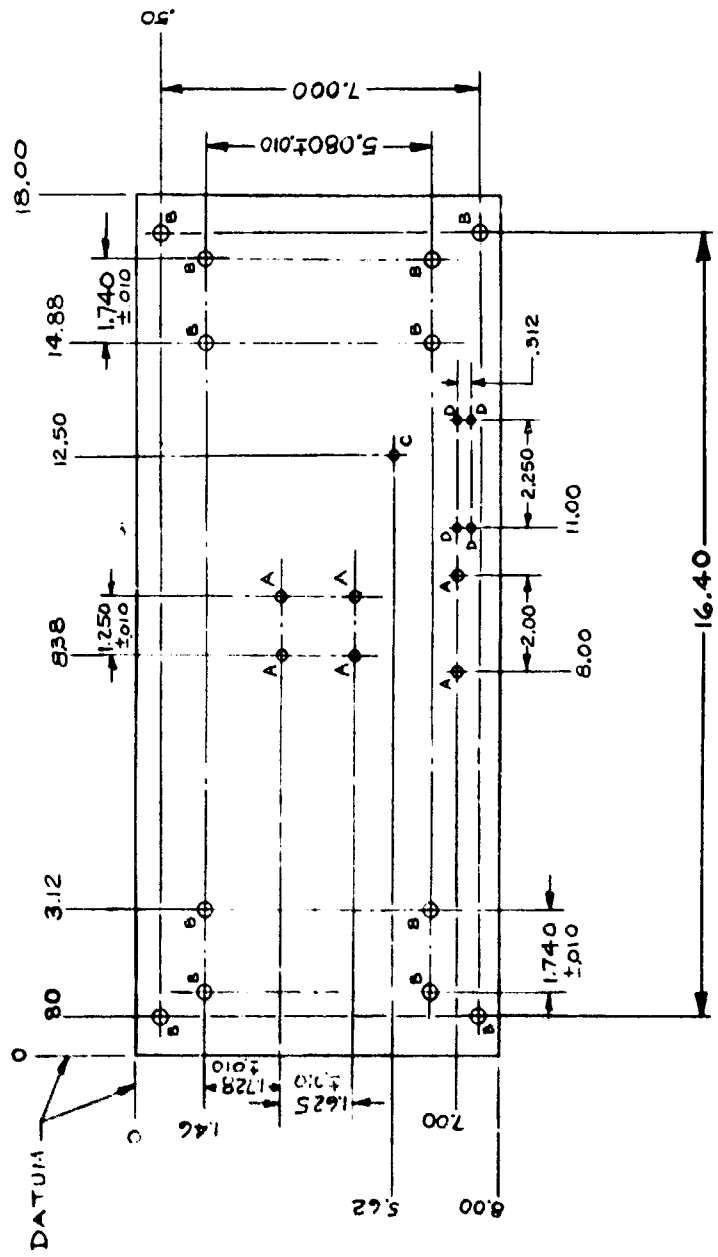

Figure A-117. Shaft (B2367356)



LIST OF MATERIAL
 ALUMINUM PLATE, 250 T-HK,
 TYPE 2024-T4

| HOLE | DESCRIPTION |
|------|------------------|
| A | .216 - .226 DIA. |
| B | .290 - .301 DIA. |
| C | .167 - .177 DIA. |
| D | .155 - .145 DIA. |
| | |

Figure A-118. Plate, Mounting (C2367357)

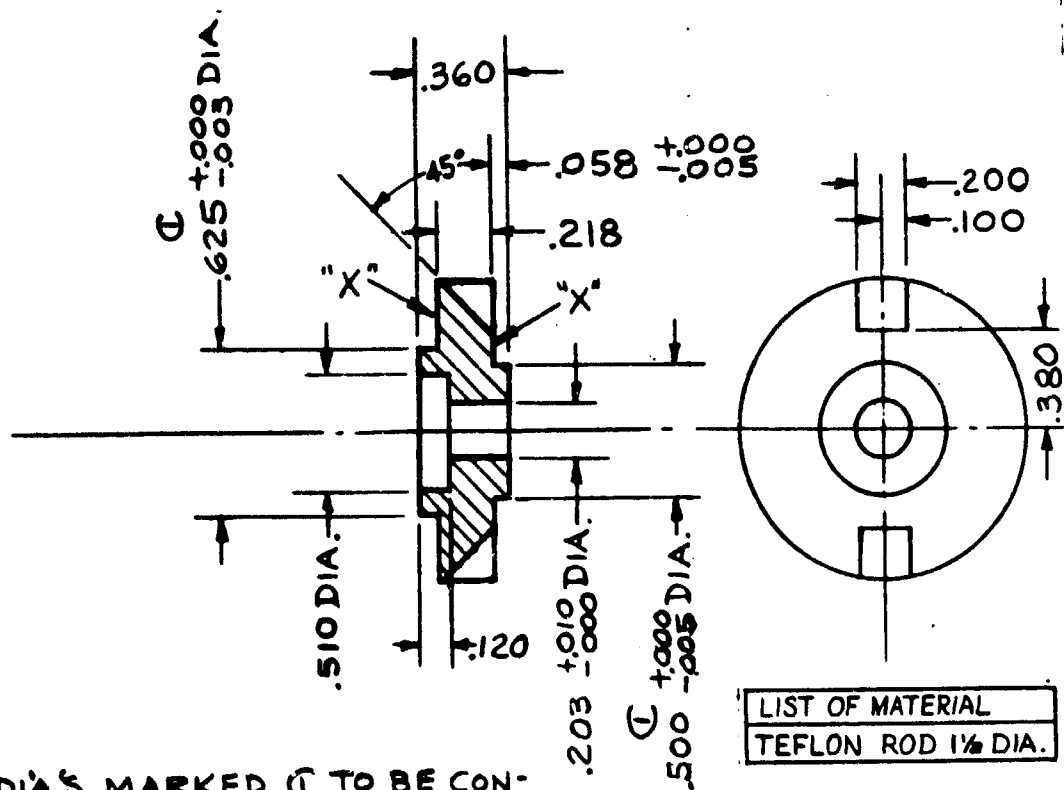

DIA'S MARKED $\text{\textcircled{C}}$ TO BE CON-
CENTRIC WITHIN .004 T.I.R AND MUST
BE PERPENDICULAR TO SURFACES
MARKED "X"
WITHIN .004 T.I.R.

| |
|---------------------|
| LIST OF MATERIAL |
| TEFLON ROD 1/8 DIA. |

Figure A-119. Spacer, Capacitor, Input (B2367358)

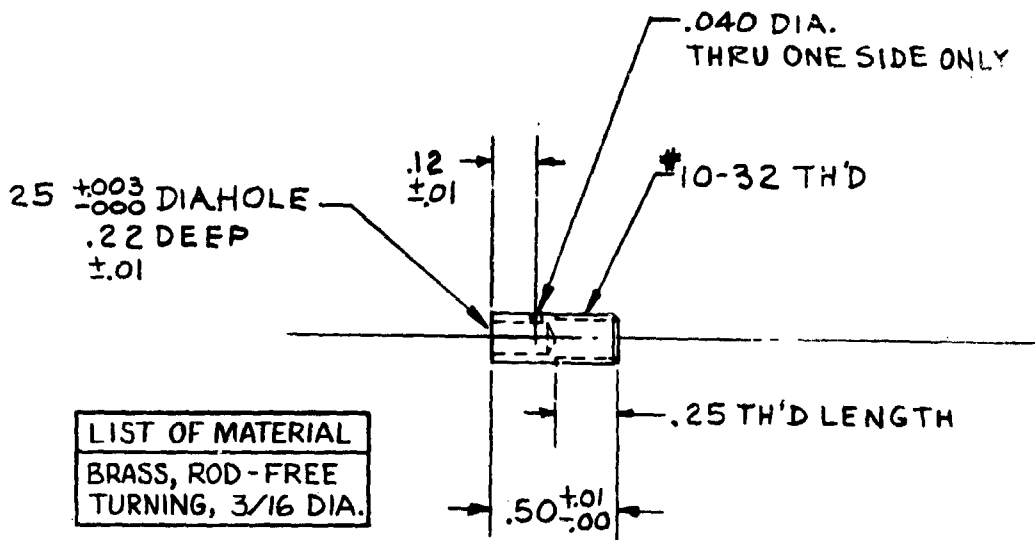
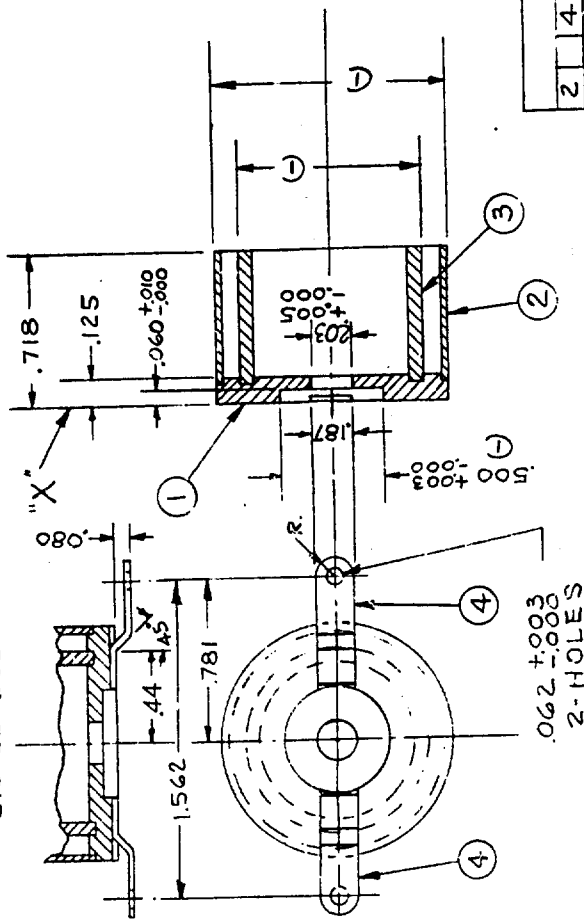

Figure A-120. Stud, Connector (B2367359)

A-12R

SILVER SOLDER ALL PARTS TOGETHER



NOTE:
 DIAS MARKED C MUST BE CONC.
 WITHIN .005 T.I.R. AND PERPENDICULAR
 TO "X" WITHIN
 .005 T.I.R.

| LIST OF MATERIAL | | PART OR IDENTIFYING NO. | | NOMENCLATURE OR DESCRIPTION | | ITEM SOURCE | | | | | |
|------------------|---|-------------------------|------------|-----------------------------|---------------|-------------|----|----|----|----|----|
| U | M | ITEM NO. | CODE IDENT | QTY | QTY PER GROUP | G1 | G2 | G3 | G4 | G5 | G6 |
| 1 | | 1 | | 1 | | | | | | | |
| 1 | | 2 | | 1 | | | | | | | |
| 1 | | 3 | | 1 | | | | | | | |
| 1 | | 4 | | 1 | | | | | | | |
| 2 | | | | | | | | | | | |

Figure A-121. Capacitor, Input (B2367361)

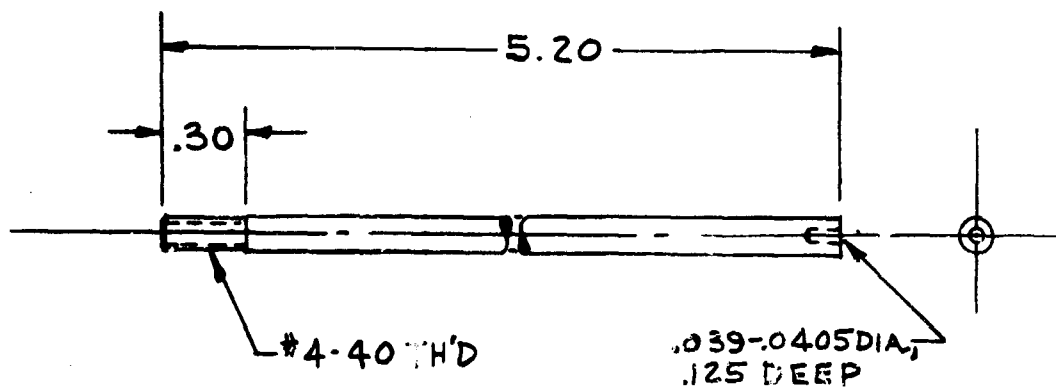

| |
|----------------------|
| LIST OF MATERIAL |
| BRASS ROD - 1/8 DIA. |
| FREE TURNING |

Figure A-123. Rod, Tuning (B2367363)

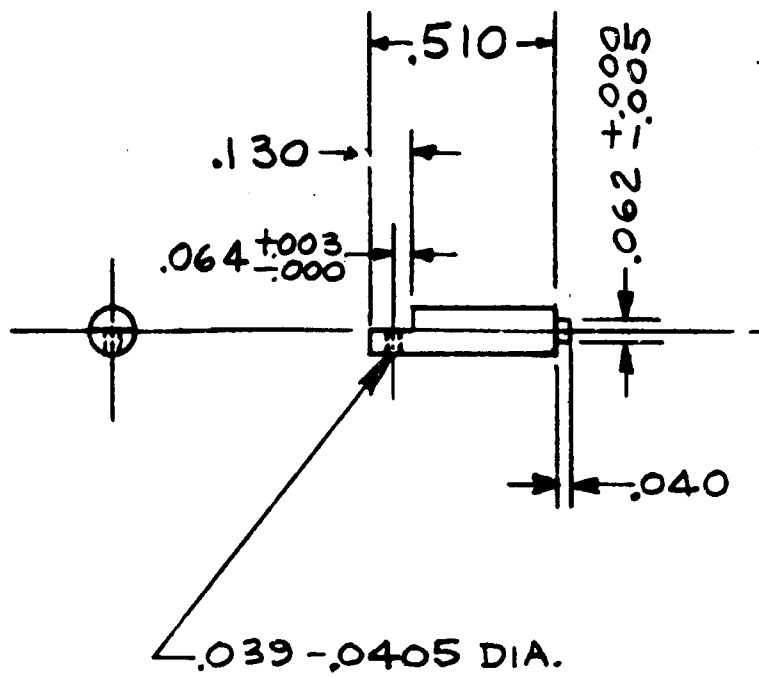

| |
|---------------------|
| LIST OF MATERIAL |
| BRASS ROD, 1/8 DIA. |
| FREE TURNING |

Figure A-124. Rod, Coupling (B2367364)

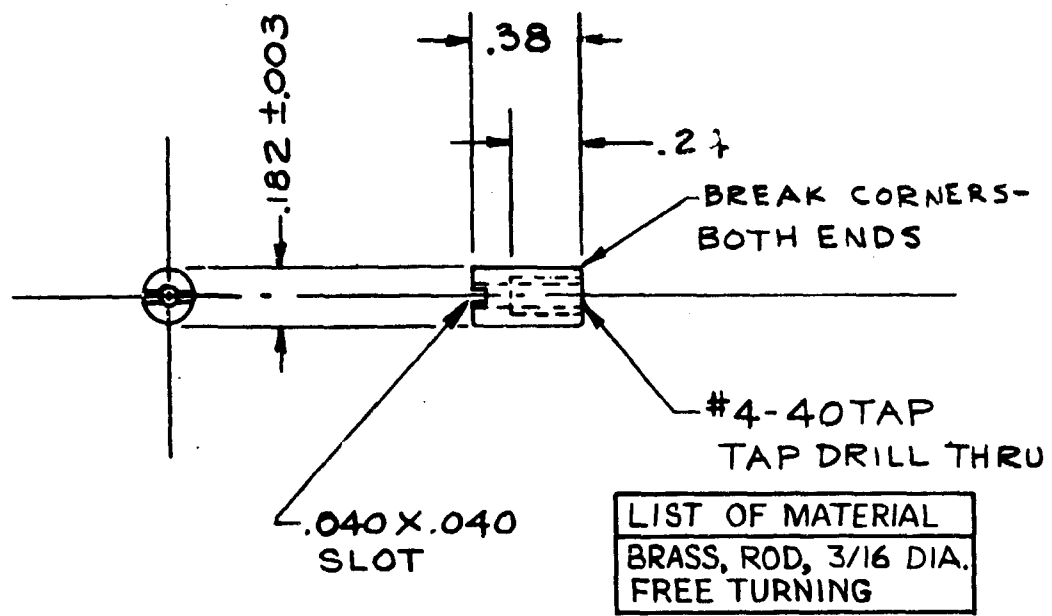
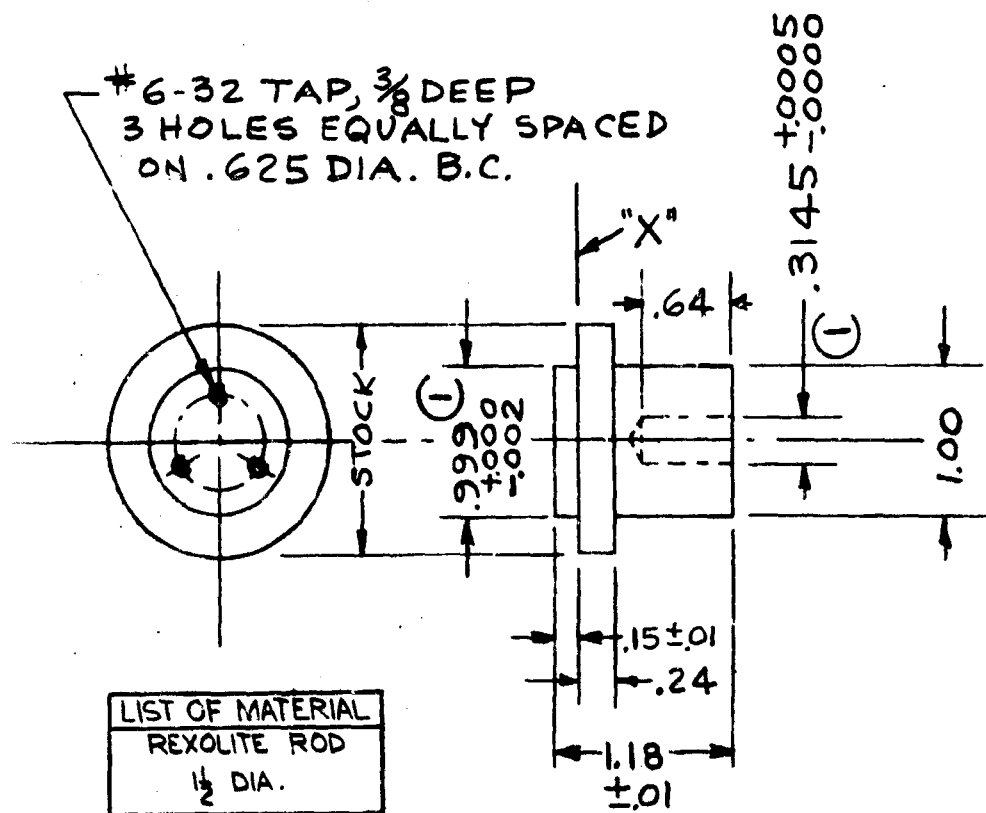
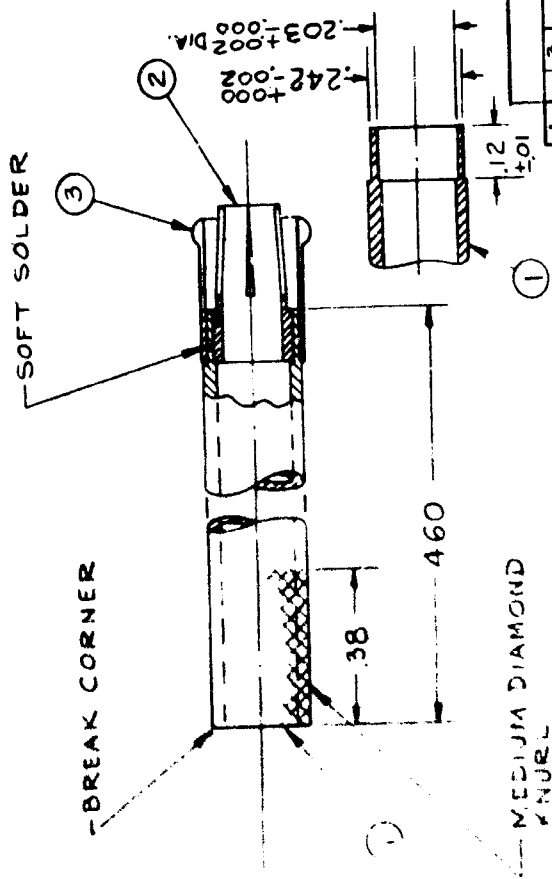

Figure A-125. Bushing, Tuning (B2367365)



DIA.'S MARKED ① SHALL BE CONCENTRIC WITHIN .002 T.I.R. AND PERPENDICULAR TO SURFACE "X" WITHIN .002 T.I.R.

Figure A-126. Hub, Rotor (B2367366)



| LIST OF MATERIAL | | | | | | | | | |
|------------------|----|------------|-------------------------|----|--|--------------------|-------------|--|--|
| ITEM NO | | CODE IDENT | PART OR IDENTIFYING NO. | | NOMENCLATURE OR DESCRIPTION | | DTTL SOURCE | | |
| 1 | 3 | | B2367388G1 | | CONTACT, OUTER | | | | |
| 1 | 2 | | B236737461 | | CONTACT, INNER | | | | |
| 1 | 1 | | | | BRASS TUBING, 1/4 O.D. X .032 WALL, HD. SEAMLESS | | | | |
| G6 | G5 | G4 | G3 | G2 | G1 | QUANTITY PER GROUP | | | |

A-135

Figure A-127. Sleeve, Tuning, Inner (B2367367)

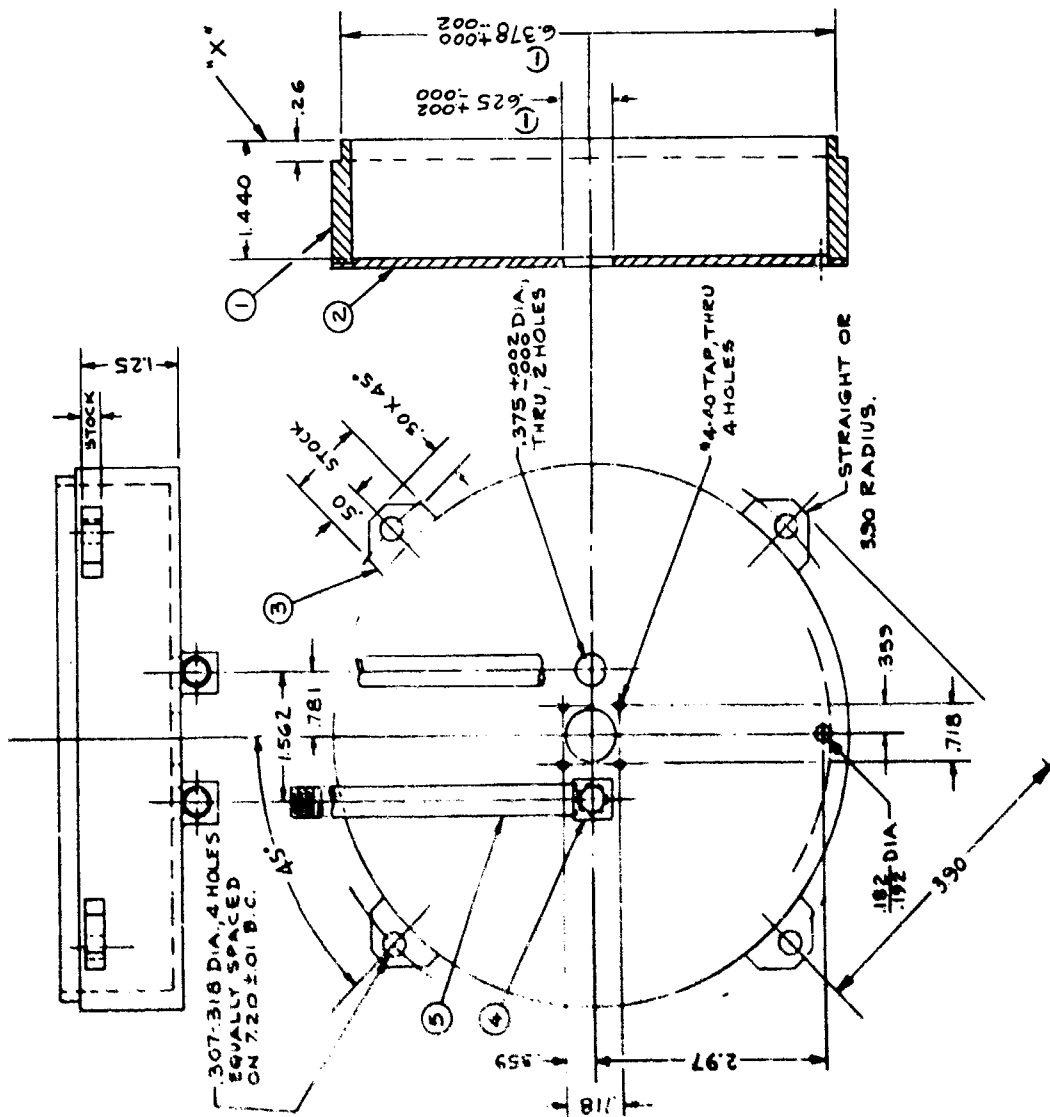

NOTES:
 1. SILVER SOLDER ALL PARTS TOGETHER BEFORE FINISH MACHINING.
 2. DIA. MARKED C MUST BE CONCENTRIC WITHIN 0.04 IN. AND MUST BE PERPENDICULAR TO SURFACE X WITHIN 0.03125 IN.

| LIST OF MATERIAL | |
|------------------|--|
| 236736061 | SLEEVE, TUNING, OUTER |
| 236734961 | HOUSING, ELBOW |
| | BRASS, RECT. BAR, 1/2 HARD, 1/4 X 1" |
| | BRASS, SHEET, 1/2 HARD, 1/8 THICK |
| | BRASS PIPE, SEAMLESS, 67.83 X 1.250 WALL |

A-136

Figure A-128. Housing, Input (C2367368)

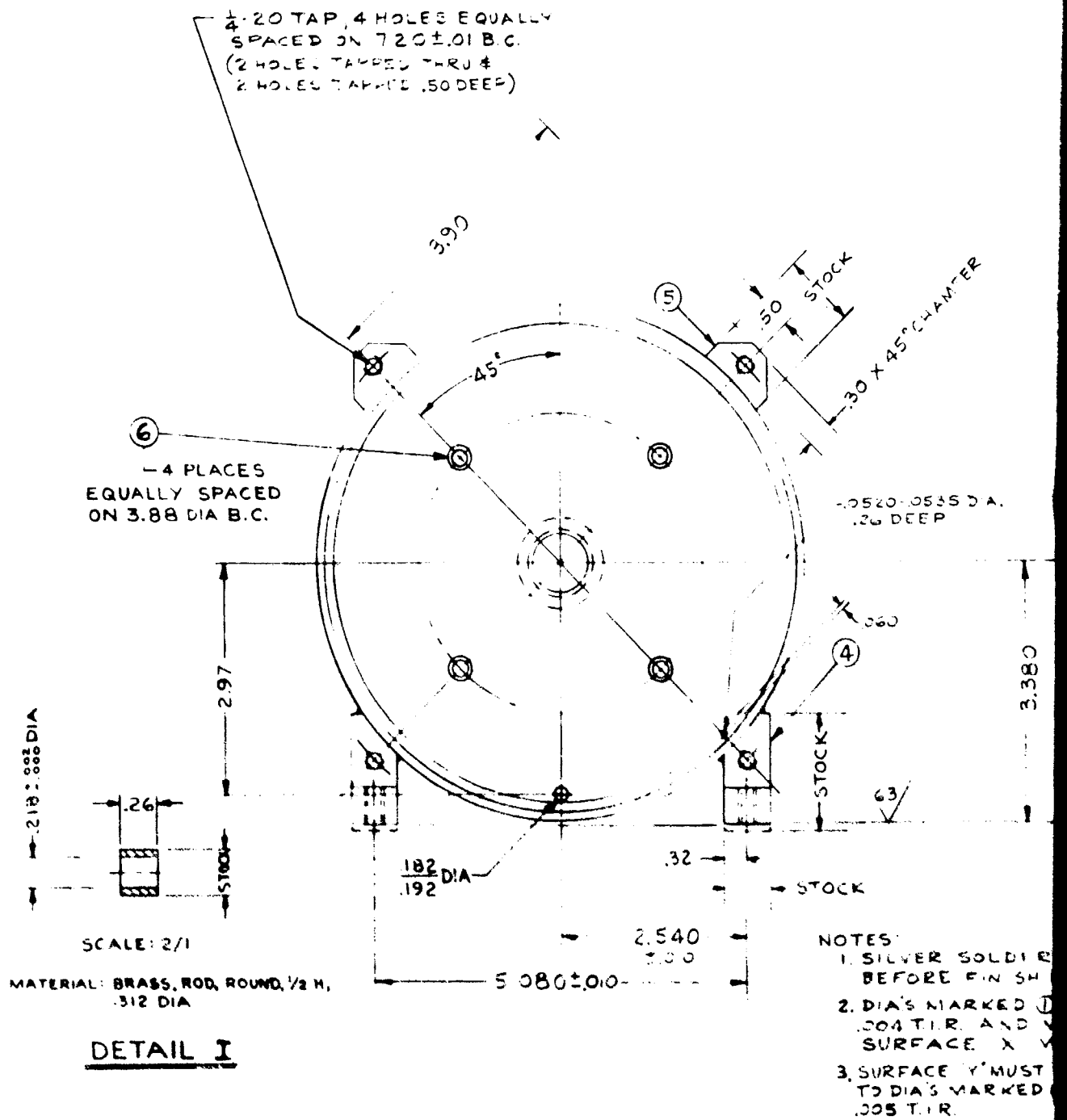

A

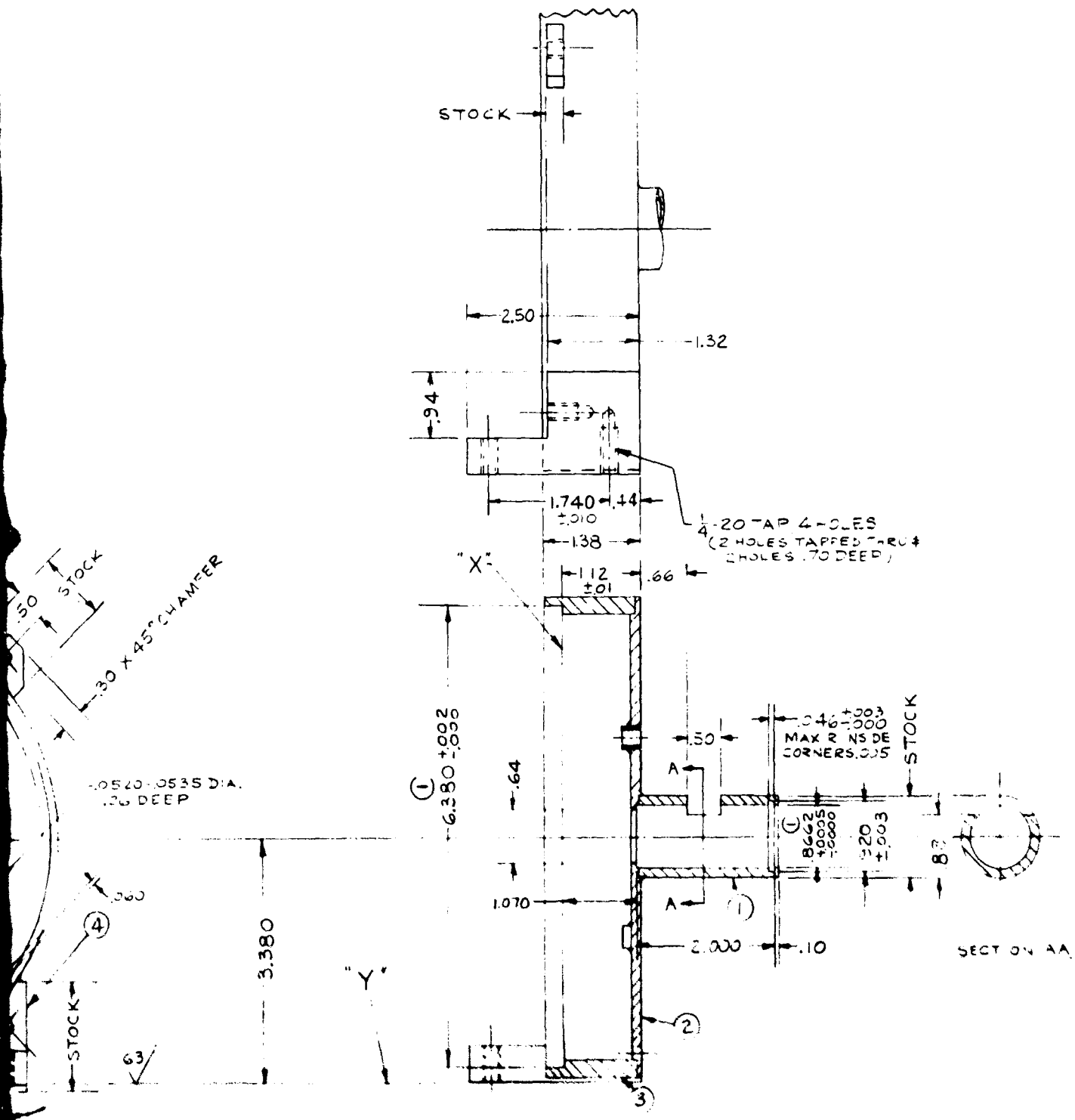

NOTES:

1. SILVER SOLDER ALL PARTS TOGETHER BEFORE FINISH MACHINING
2. DIA'S MARKED Ⓛ MUST BE CONCENTRIC WITHIN .004 T.I.R. AND MUST BE PERPENDICULAR TO SURFACE 'X' WITHIN .004 T.I.R.
3. SURFACE 'Y' MUST BE PARALLEL TO DIA'S MARKED Ⓛ WITHIN .005 T.I.R.

Figure A-129. Housing, Output (D2367369)

A-137

B

| A ORIGINAL ISSUE | | REVISIONS | | |
|------------------|---------------|--|---------|----------|
| SYM | 3A | DESCRIPTION | DATE | APPROVED |
| B | 3B | ADDED ITEM 33. <i>No. Titled</i> | 4-12-65 | |
| C | 2B | ITEM 13 PART-NO. WAS 755597, UG58A <i>J. Zubris</i> | 5-10-65 | |

| | | | | |
|---------------|---------|---|---|---|
| SHEET | 1 | 1 | 1 | |
| ISSUE | C | B | B | |
| NEXT ASSEMBLY | G1 | | G | G |
| FIRST USED ON | FAA-1LS | | | |

Figure A-130. Sideband Generator Assembly (A2367370) (Sheet 1 of 3)

| LIST OF MATERIALS | | | | | | | | | | NOMENCLATURE OR DESCRIPTION | ITEM SOURCE | | |
|--------------------|----|----|----|----|----|--------|----------|-------------|------|-----------------------------|-------------|--|--|
| QUANTITY PER GROUP | | | | | | U OF M | ITEM NO. | CODE IDENT. | SIZE | | | PART OR IDENTIFYING NO. | |
| G6 | G5 | G4 | G3 | G2 | G1 | | | | | | | | |
| | | | | | 1 | 1 | 1 | | | C | 2367357G1 | PLATE, MOUNTING | |
| | | | | | 2 | 1 | 2 | | | D | 2367369G1 | HOUSING, OUTPUT | |
| | | | | | 2 | 1 | 3 | | | C | 2367368G1 | HOUSING, INPUT | |
| | | | | | 1 | 1 | 4 | | | C | 2367352G1 | ROTOR, 150~ | |
| | | | | | 1 | 1 | 5 | | | C | 2367353G1 | ROTOR, 90~ | |
| | | | | | 1 | 1 | 6 | | | D | 2367350G1 | PLATE, PICKUP 150~ | |
| | | | | | 1 | 1 | 7 | | | D | 2367351G1 | PLATE, PICKUP 90~ | |
| | | | | | 4 | 1 | 8 | | | B | 2367367G1 | SLEEVE, TUNING, INNER | |
| | | | | | 4 | 1 | 9 | | | B | 2367365G1 | BUSHING, TUNING | |
| | | | | | 4 | 1 | 10 | | | B | 2367363G1 | ROD, TUNING | |
| | | | | | 4 | 1 | 11 | | | B | 2367364G1 | ROD, COUPLING | |
| | | | | | 2 | 1 | 12 | | | B | 2367359G1 | STUD, CONNECTOR | |
| | | | | | 2 | 1 | 13 | | | | | CONNECTOR, TYPE N, UG58/U | |
| | | | | | 2 | 1 | 14 | | | | 280155A308 | PIN, STRAIGHT, SPIROL, .052 DIA X.25LG | |
| | | | | | 4 | 1 | 15 | | | B | 2367354G1 | CLAMP, TUNING | |
| | | | | | 4 | 1 | 16 | | | | 340422H008 | PACKING (O" RING) | |
| | | | | | 2 | 1 | 17 | | | B | 2367358G1 | SPACER, CAPACITOR, INPUT | |
| | | | | | 4 | 1 | 18 | | | B | 2367348G1 | PLUG, ELBOW | |

Figure A-130. Sideband Generator Assembly (A2367370) (Sheet 2 of 3)

| LIST OF MATERIALS | | | | | | | | | | ITEM SOURCE | | |
|--------------------|----|----|---------|-------------|-------------------------|-----------------------------|----|----|----|-------------|---|--|
| QUANTITY PER GROUP | | | ITEM NO | CODE IDENT. | PART OR IDENTIFYING NO. | NOMENCLATURE OR DESCRIPTION | | | | | | |
| G6 | G5 | G4 | | | | | G3 | G2 | G1 | U OF M | | |
| | | | | | | 2 | 1 | 19 | | B 2367361G1 | CAPACITOR, INPUT | |
| | | | | | | 2 | 1 | 20 | | B 2367362G1 | CAPACITOR, OUTPUT | |
| | | | | | | 2 | 1 | 21 | | B 2367366G1 | HUB, ROTOR | |
| | | | | | | 2 | 1 | 22 | | 280009H332 | PIN, STRAIGHT, SPRING TYPE .094 DIA X 1.000 L | |
| | | | | | | 2 | 1 | 23 | | B 2367356G1 | SHAFT | |
| | | | | | | 2 | 1 | 24 | | B 2367371G1 | WASHER, SPRING | |
| | | | | | | 4 | 1 | 25 | | | RMB BALL BEARING #RF822 | |
| | | | | | | | | | | | TEK BEARING CO. NEWARK 2, N.J. | |
| | | | | | | 4 | 1 | 26 | | 114130 | SCREW, SET, HEX SOCKET, #8-32 X .25 LG | |
| | | | | | | 2 | 1 | 27 | | B 2367355G1 | SPACER, BEARING | |
| | | | | | | 2 | 1 | 28 | | 235202A086 | RING, RETAINING (INTERNAL, FLAT) | |
| | | | | | | 2 | 1 | 29 | | | BELLOWS COUPLING, STERLING INSTRUMENT CAT. # G 404-62 | |
| | | | | | | 1 | 1 | 30 | | C 2120782G1 | MOTOR, HYSTERESIS-CLASS "A"-MOD | |
| | | | | | | 1 | 1 | 31 | | B 2367372G1 | BLOCK, MOTOR | |
| | | | | | | 2 | 1 | 32 | | B 2367373G1 | INSULATOR | |
| | | | | | | 2 | 1 | 33 | | D 2367405G1 | BRACKET | |

Figure A-130. Sideband Generator Assembly (A2367370) (Sheet 3 of 3)

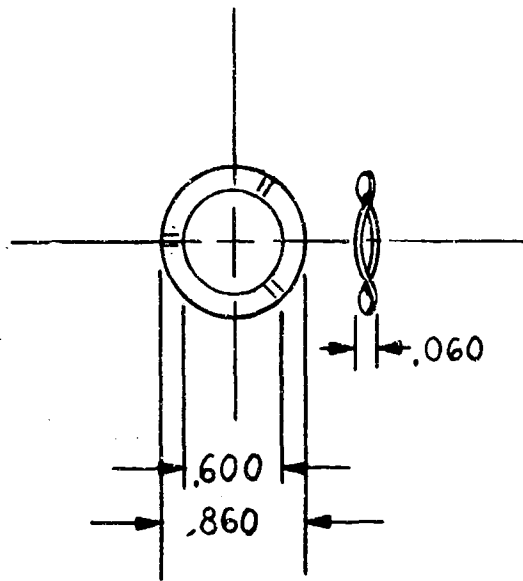

| |
|--|
| LIST OF MATERIAL |
| STAINLESS STEEL - TYPE 302 - SPRING TEMPER, .012 THICK |

Figure A-131. Washer, Spring (B2367371)

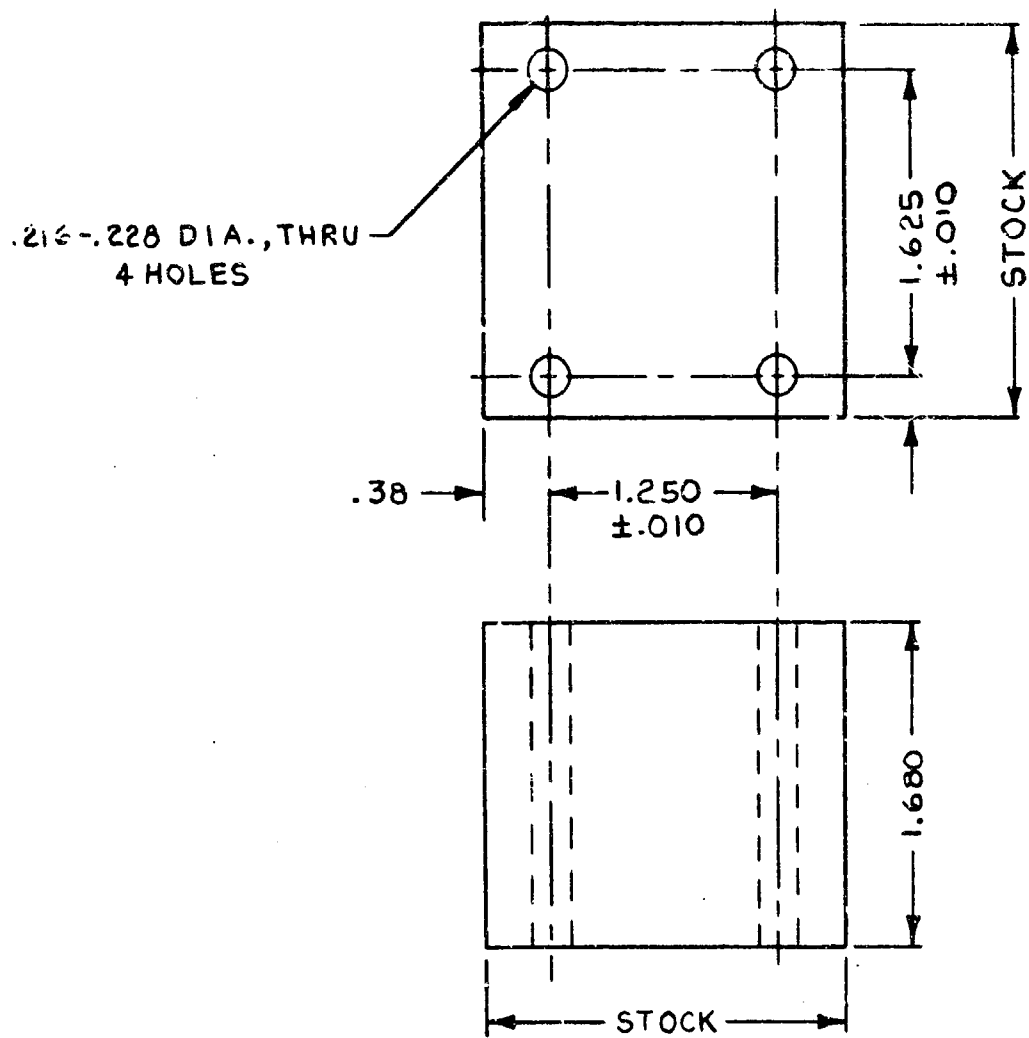

| LIST OF MATERIAL |
|---------------------------------|
| ALUMINUM ROD, 2" SQ. 2024-T4 |
| IRIDITE #14 |

Figure A-132. Block, Motor (B2367372)

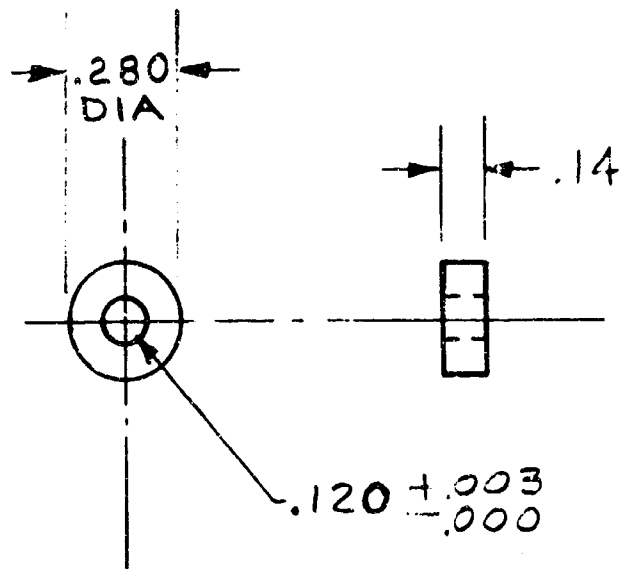

| |
|---------------------------------|
| LIST OF MATERIAL |
| TEFLON ROD, $\frac{5}{16}$ DIA. |

Figure A-133. Insulator (B2367373)

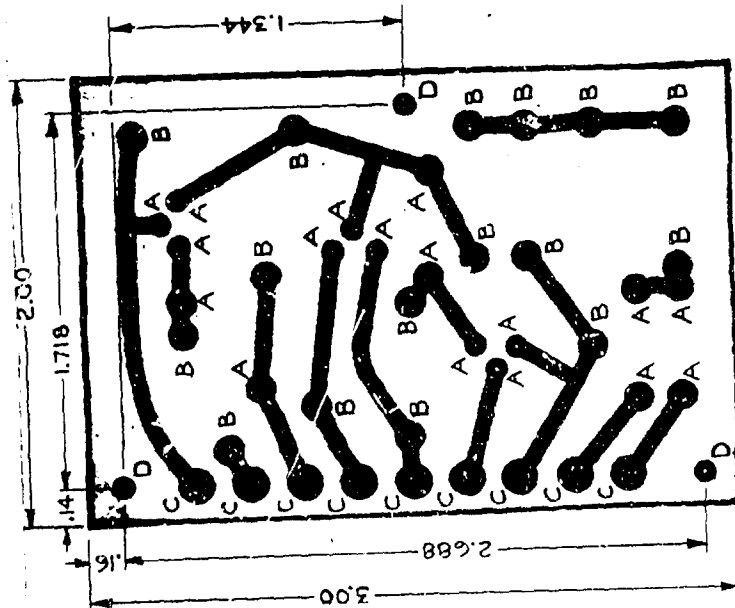

| HOLE | DESCRIPTION |
|------|---------------|
| A | .033-.040 DIA |
| B | .047-.055 DIA |
| C | .092-.096 DIA |
| D | .135-.145 DIA |

NOTES:

1. UNLESS A DIMENSION OR TOLERANCE IS SPECIFICALLY STATED, HOLE CENTERS SHALL BE LOCATED AS FOLLOWS.
 (A) FOR HAND INSERTION OF PARTS, WITHIN $\pm .008$ OF THE TRUE .10 OR .025 COORDINATE GRID POSITION.
 (B) FOR MACHINE INSERTION OF PARTS, WITHIN $\pm .002$ OF THE TRUE .10 OR .025 COORDINATE GRID POSITION AND IF TOOL HOLE CENTER REFERENCE POINTS OR THE BOARD REFERENCE EDGES (WHICHEVER IS APPLICABLE) ARE OFFSET FROM THE TRUE COORDINATE GRID, THIS OFFSET SHALL BE UNIFORM WITHIN $\pm .001$ FOR ANY GIVEN LOT OF BOARDS.
2. EACH PRODUCTION ORDER SHALL STATE THE HOLE POSITION TOLERANCE APPLICABLE FOR THAT SPECIFIC MANUFACTURING LOT.
3. TRIM BOARD ALONG INSIDE EDGE OF TRIM LINE. MAINTAIN DIMENSIONS WITHIN SPECIFIED LIMITS. AFTER TRIMMING REMOVE ALL EXCESS COPPER ALONG THE EDGE.
4. FOR MASTER ART SEE SHEET 1 OF THIS DRAWING. FABRICATED PRINTED WIRING PATTERN SHALL MEET THE REQUIREMENTS OF SPECIFICATION #

5. MATERIAL: GLASS FABRIC BASE, EPOXY PLASTIC SHEET, LAMINATED .062 THK, SINGLE CLAD WITH 2 OZ COPPER, TYPE DESIGNATION GF .042 C% PER SPECIFICATION MIL-P-13949C.
6. AFTER ETCHING AND DRILLING, APPLY SOLDER COAT .003 THK MIN TO ALL COPPER SURFACES.
7. AFTER SHEARING, FINE SAND ALL EDGES OF BOARD.

SHEET 2 IS A SIZE

Figure A-134. Printed Wiring Board (Drilled) (B2367380) (Sheet 1 of 2)

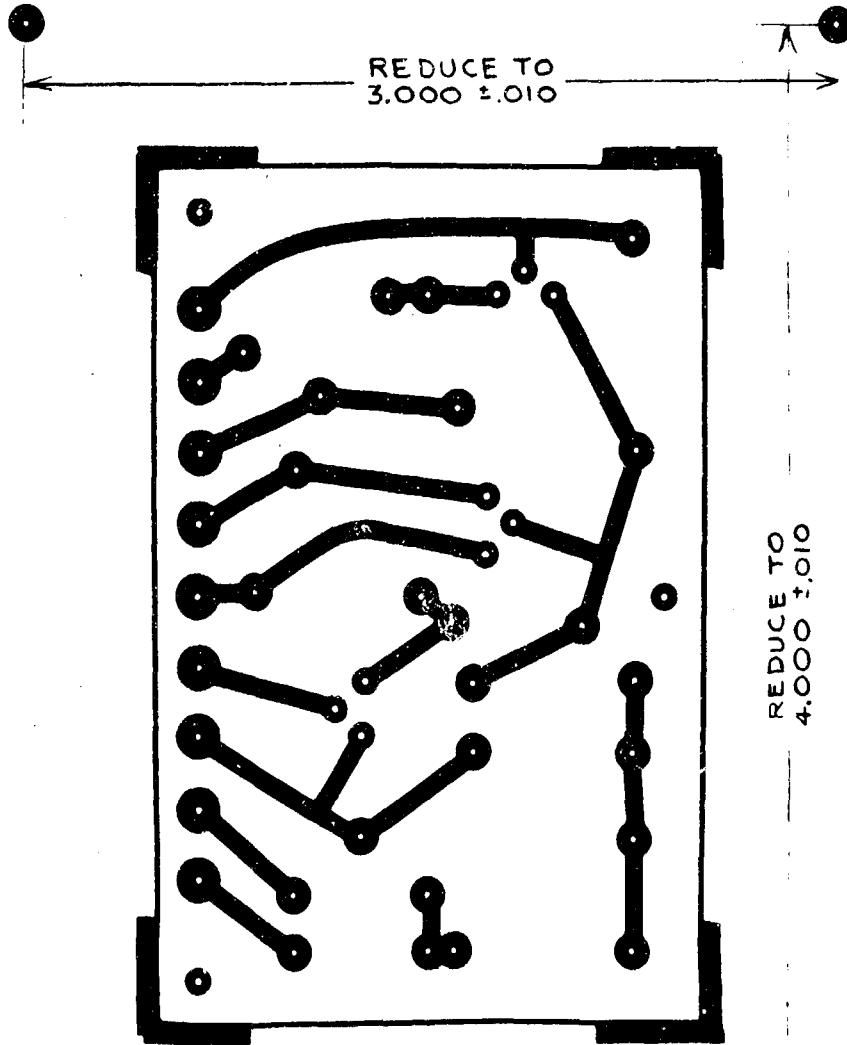

NOTE:
 THE ORIGINAL MASTER ART (OR A REPRODUCTION PREPARED BY A METHOD WHICH WILL ASSURE DIMENSIONAL STABILITY) IS AN ACCURATE ENLARGED SCALE MASTER FOR PRODUCTION OF THE DEPICTED ITEM.
 PRINTS OF THIS DRAWING ARE FOR REFERENCE ONLY.

Figure A-134. Printed Wiring Board (Master) (A2367350) (Sheet 2 of 2)

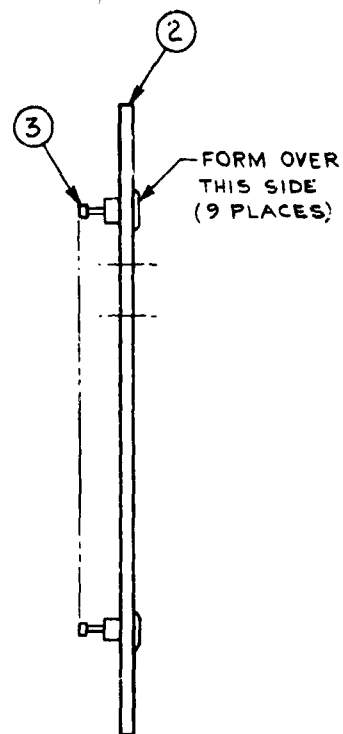
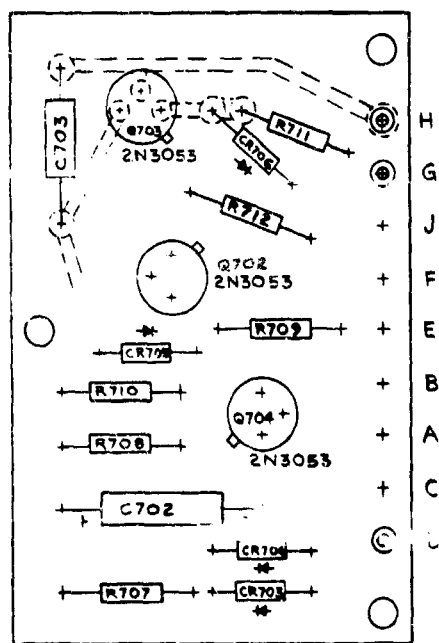

| LIST OF MATERIAL | | | | | |
|------------------|-----|------|------|-----------|--------------------------------|
| GROUP | QTY | U OF | ITEM | PART OR | NOMENCLATURE OR DESCRIPTION |
| G3 | G2 | G1 | M | NO. | IDENTIFYING NO. |
| | 9 | 1 | 3 | 363992 | TERMINAL STUD, SOLID |
| | 1 | 1 | 2 | 2367380G1 | PRINTED WIRING BOARD (DRILLED) |
| | | 20 | 1 | | E.P.L. |

Figure A-135. Printed Wiring Board (Assembly) (C2367381)

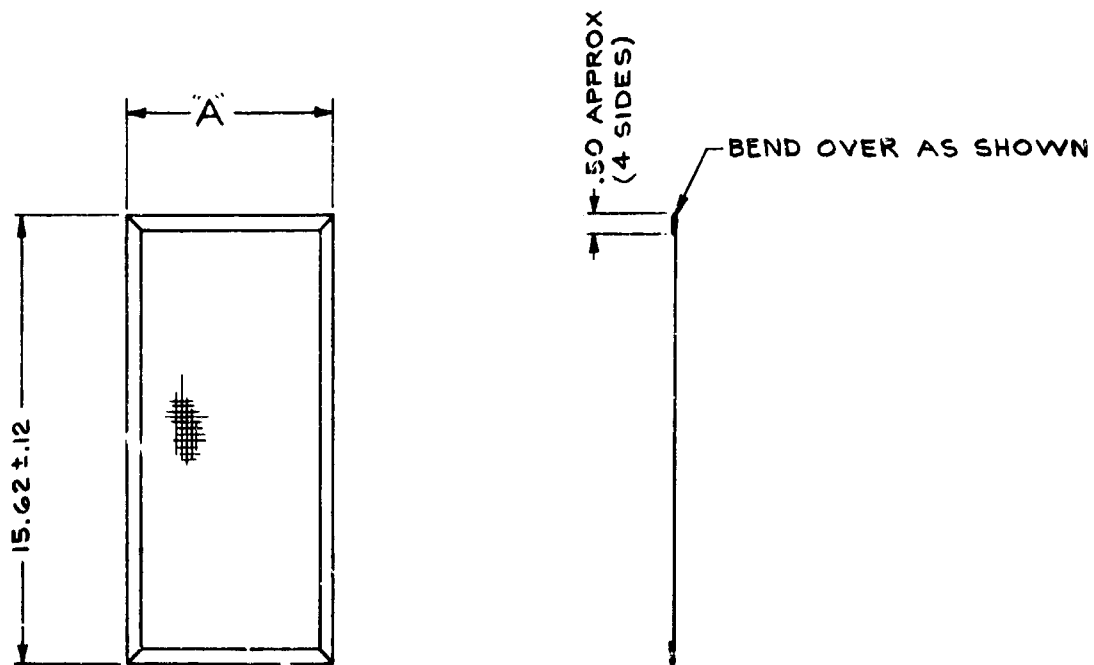

| PART NO. | A |
|-----------|-----------------|
| 2367387G1 | $7.38 \pm .12$ |
| 2367387G2 | $15.00 \pm .26$ |

| LIST OF MATERIAL |
|--|
| ALUMINUM, STANDARD FINE MESH SCREENING |

Figure A-136. Screen (C2367387)

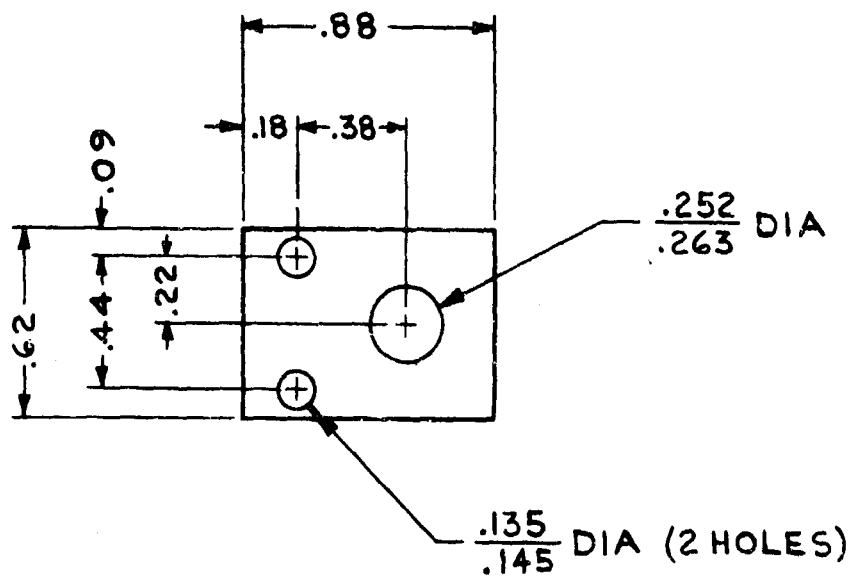

| LIST OF MATERIAL |
|------------------------|
| TEFLON SHEET 5/32 THK. |

Figure A-137. Insulator (B2367389)

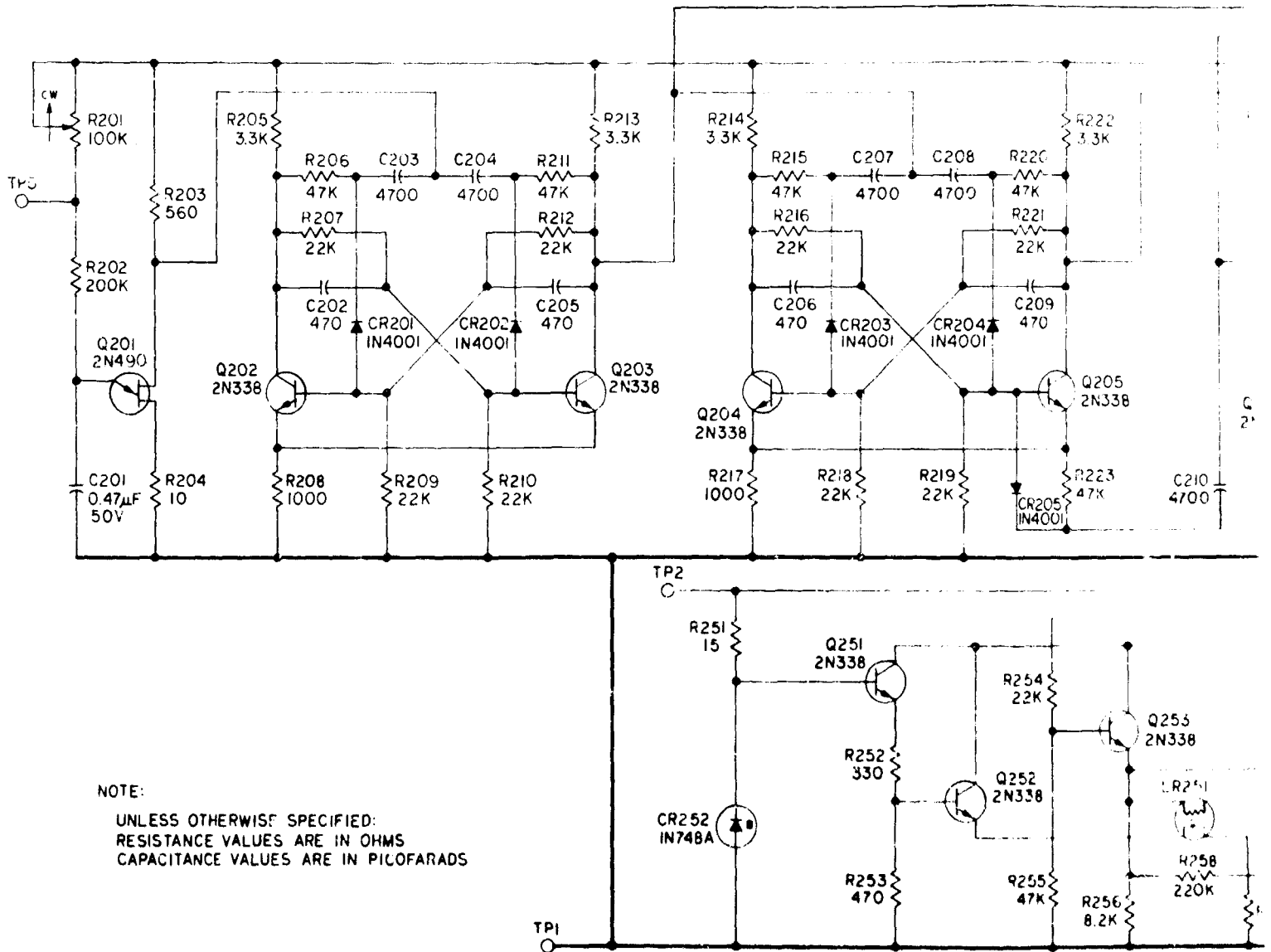

A

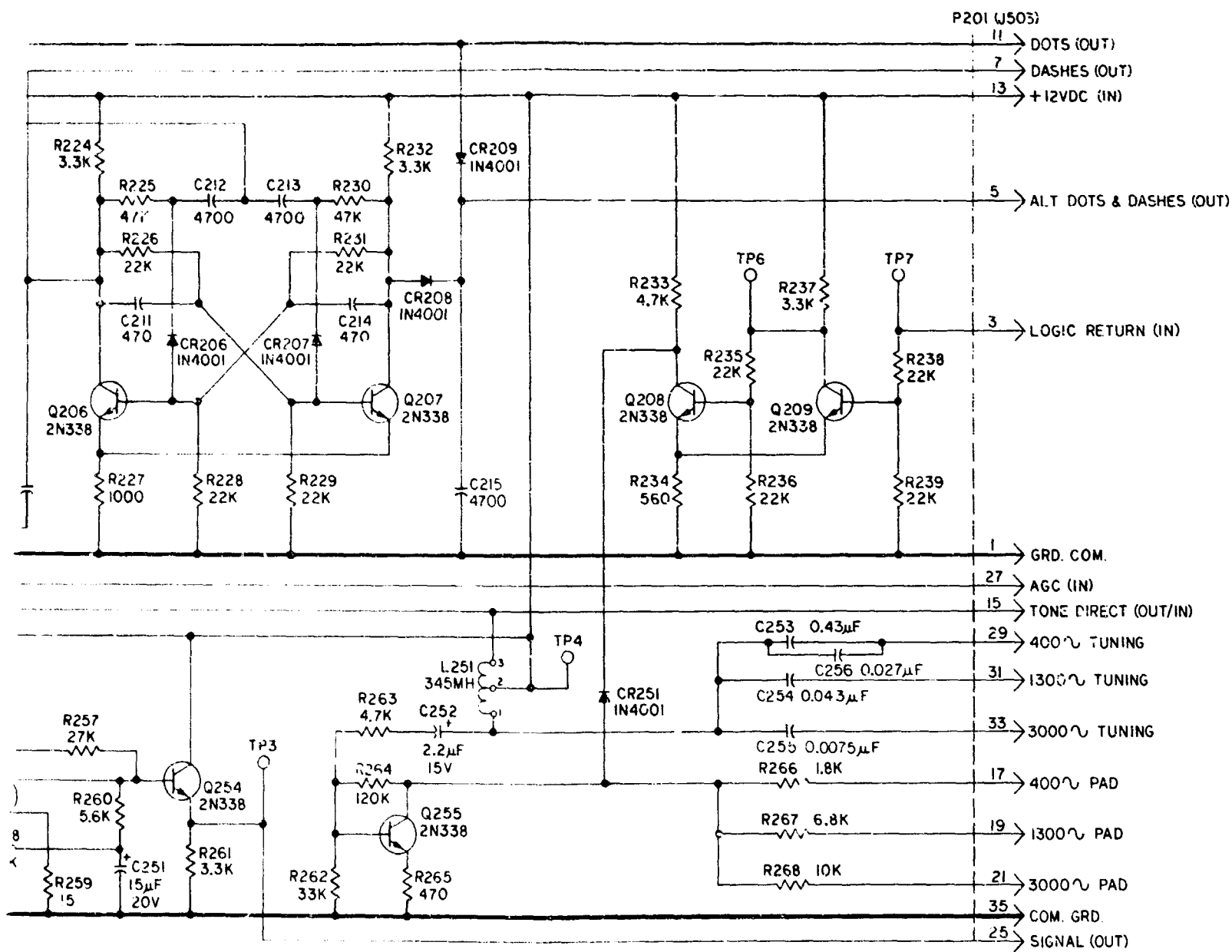
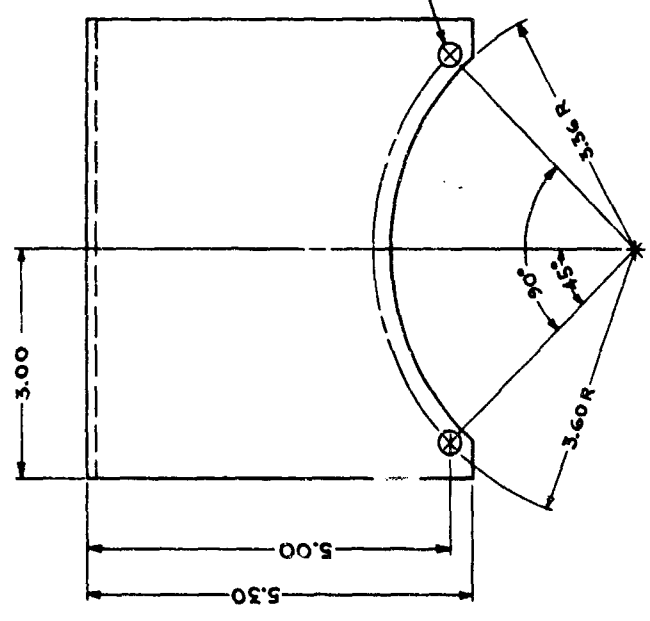
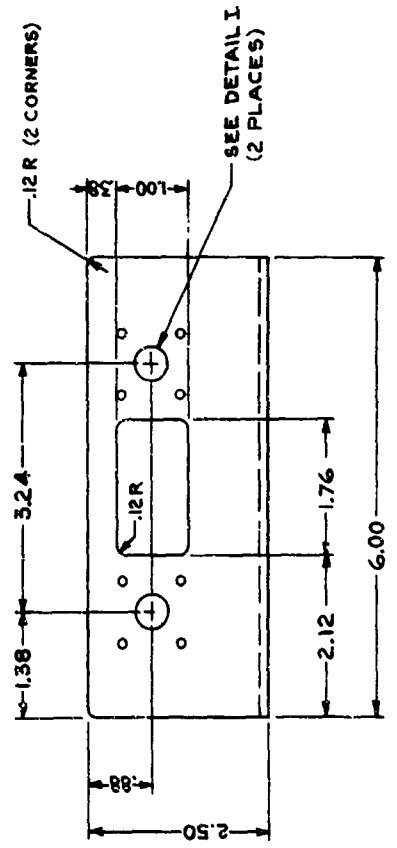
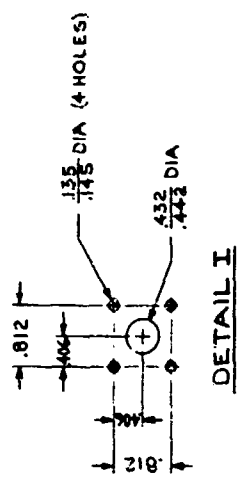

Figure A-138. Schematic Diagram,
Tone Generator and Keyer
Marker Beacon (J2367391)

B



| LIST OF MATERIAL |
|---|
| ALUMINUM, ALLOY, SHEET, .125 THK, TYPE 5052-H32 |
| IRIDITE #14-2 (IRIDESCENT YELLOW) |

Figure A-139. Bracket (D2367405)

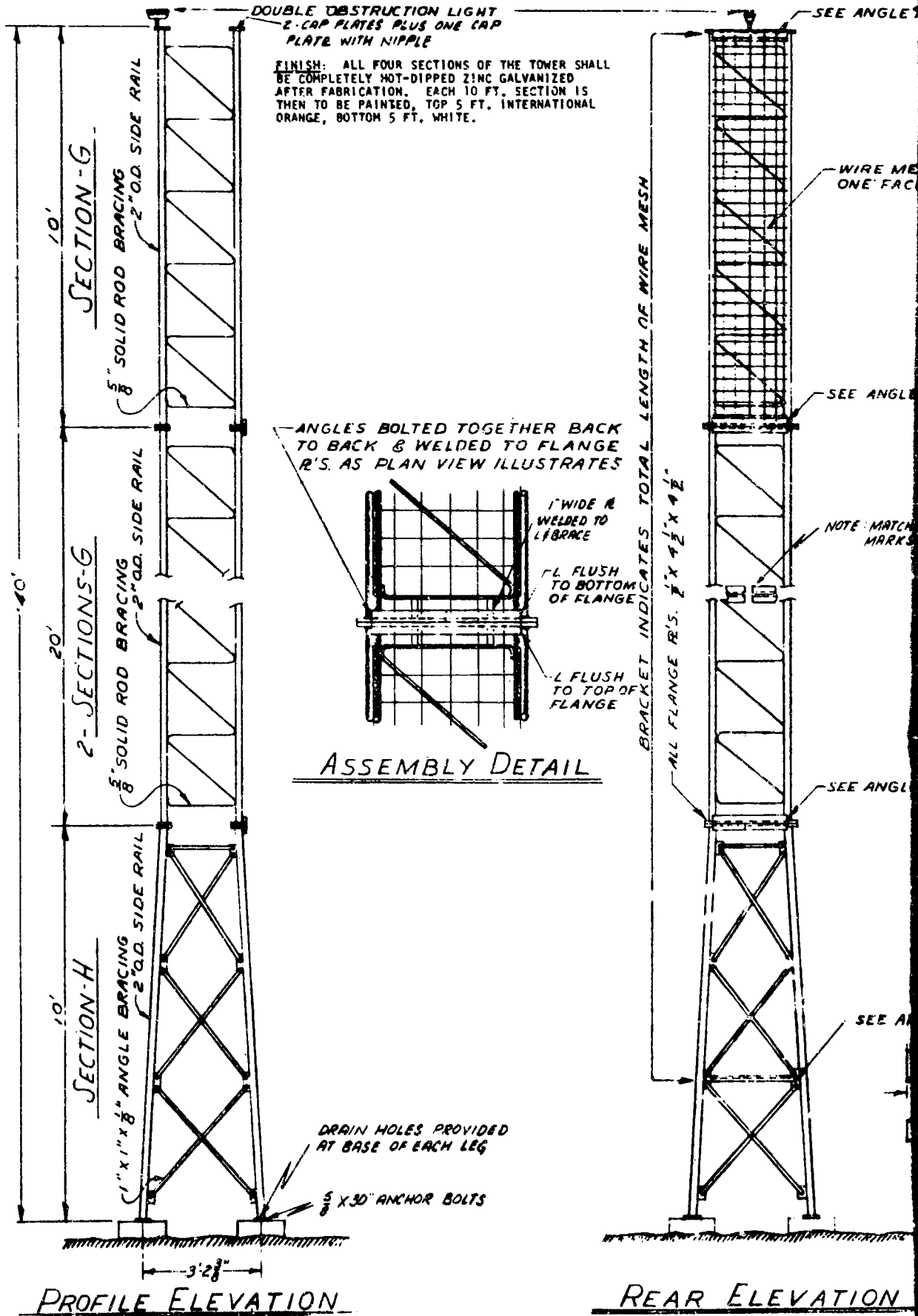

A

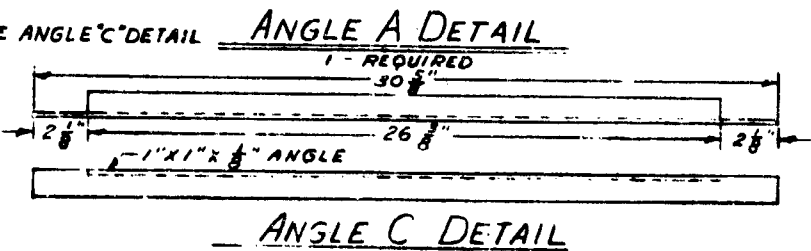
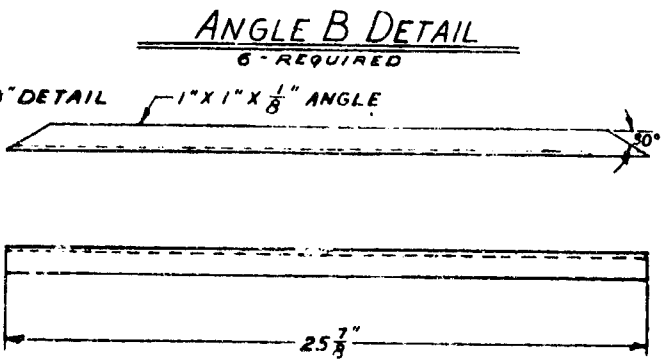
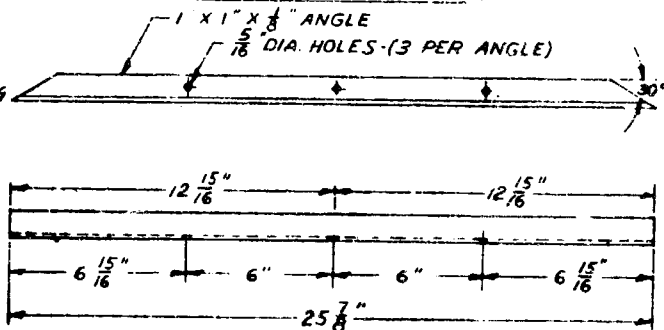
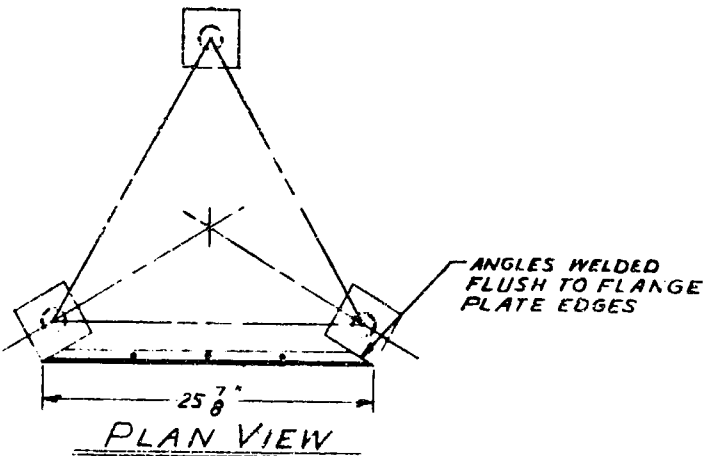
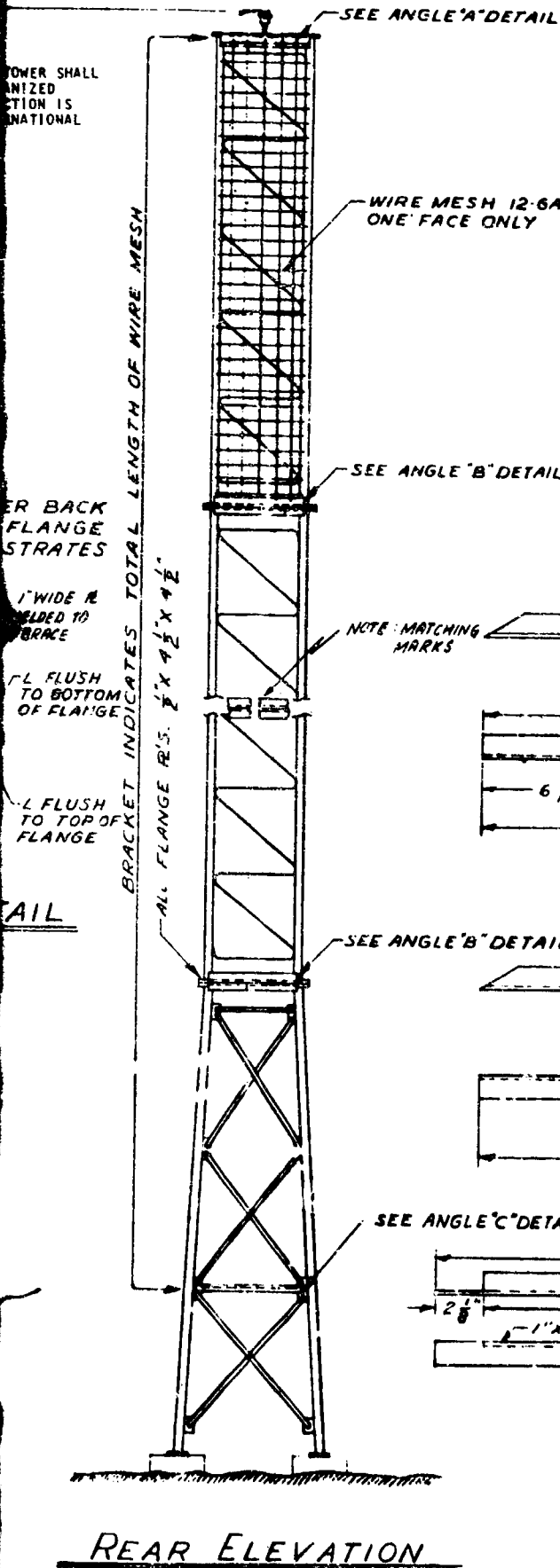

A-140. Low Cost Glide Slope (D2367439)

A-151

B

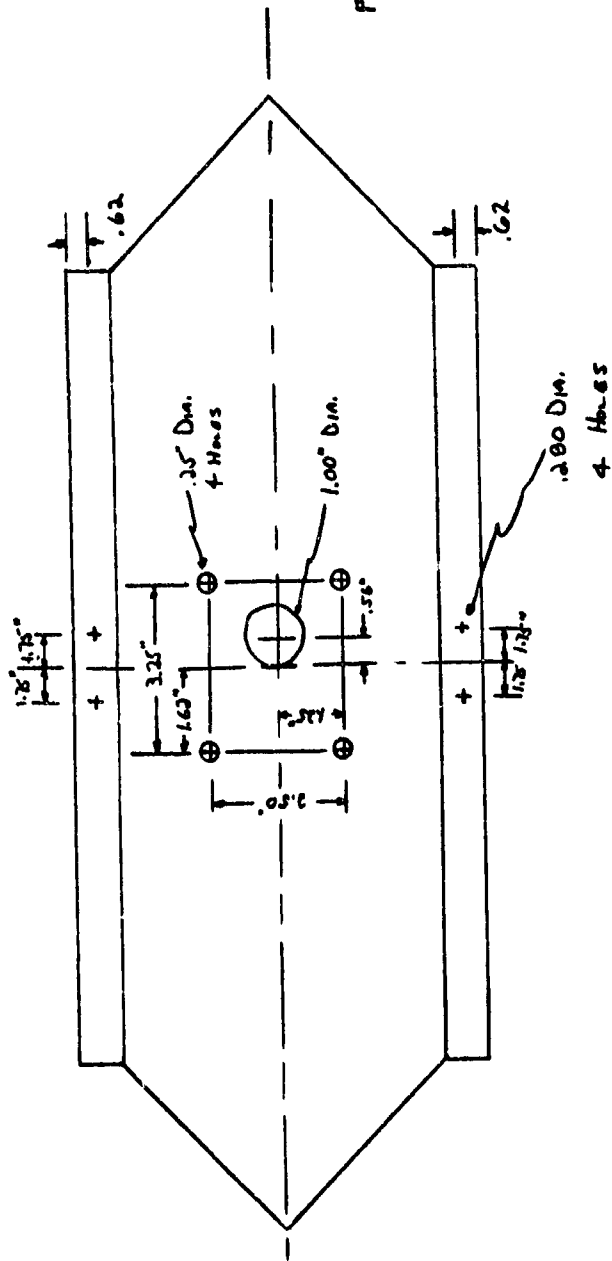

- FINISH: IRIDIUM, THEN PAINT AS FOLLOWS:
1. APPLY WASH PRIMER AS PER MIL-C-15338
 2. APPLY ZINC CHROMATE PRIMER AS PER MIL-P-8585
 3. APPLY FINAL COAT INTERMEDIATE ORANGE, COLOR SPECIFIED BY FEDERAL STANDARD #595

A-152

Figure A-141. ILS Ground Plane Drilling Diagram (BX2205292)

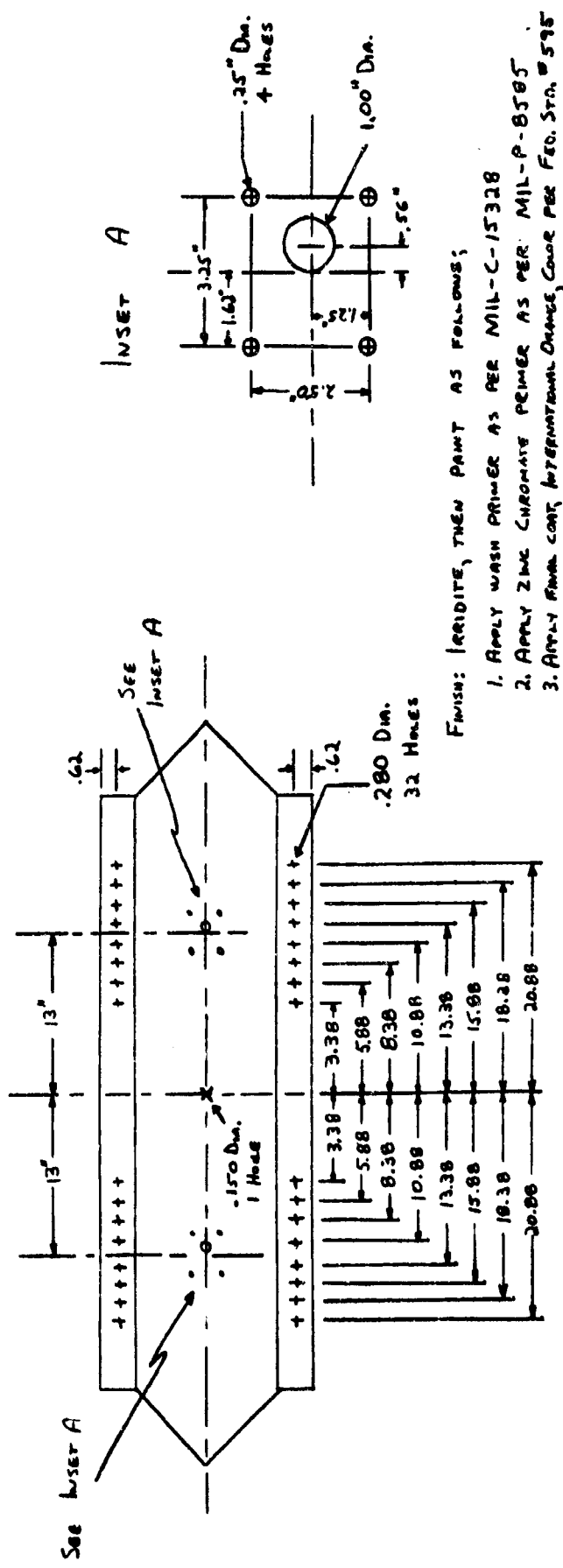

A-153

Figure A-142. ILS Ground Plane Drilling Diagram (BX2205293)

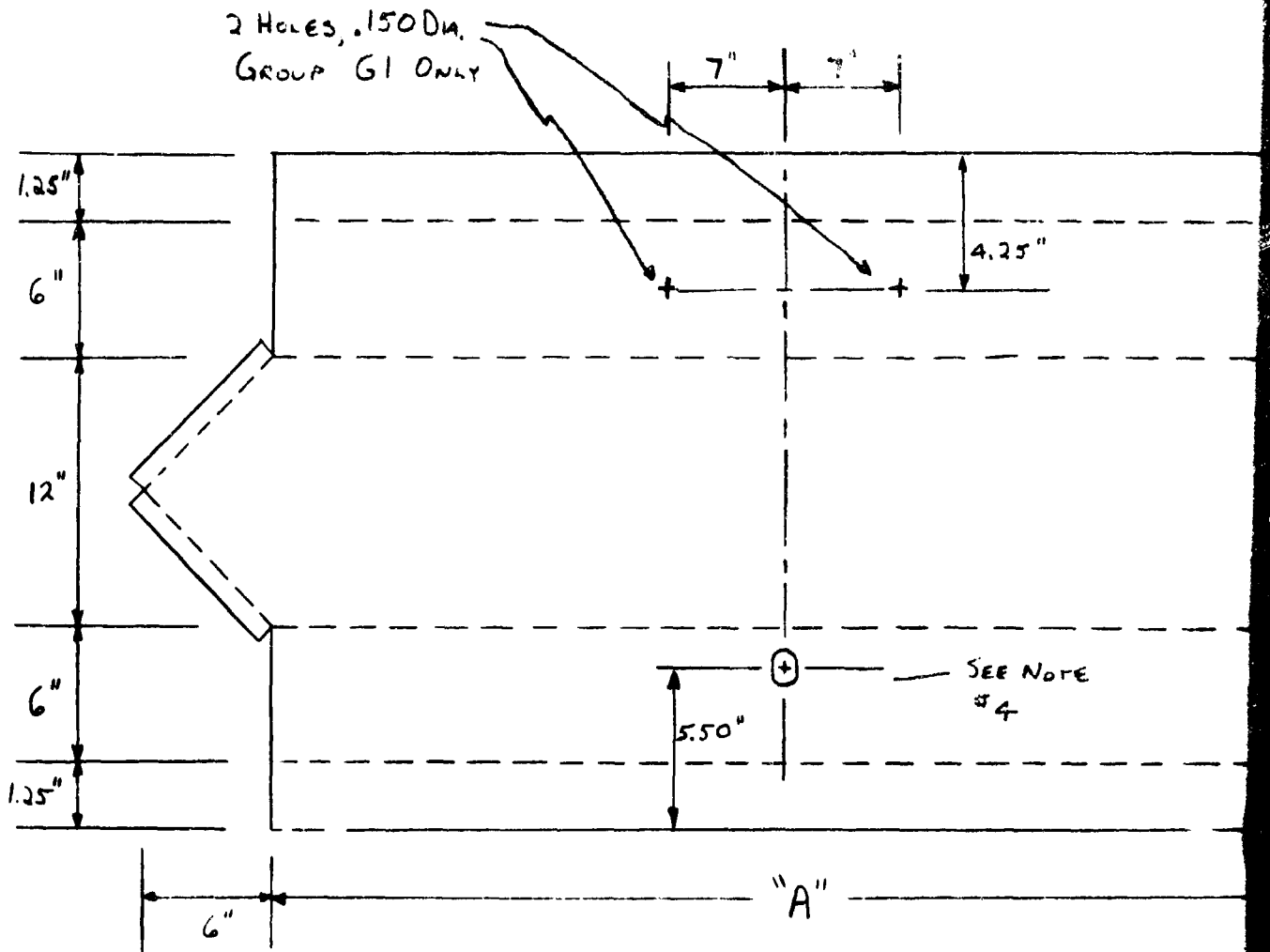

NOTES:

1. ALL DIMENSIONS TO BENDS ARE NOMINAL TO CENTER OF BEND.
2. "A" DIMENSION IS AS FOLLOWS

| | |
|----|-------------------|
| G1 | "A" = 4 ft. 0 in. |
| G2 | "A" = 22 in. |
3. WELD ALL CORNERS WHICH BUTT TOGETHER

A

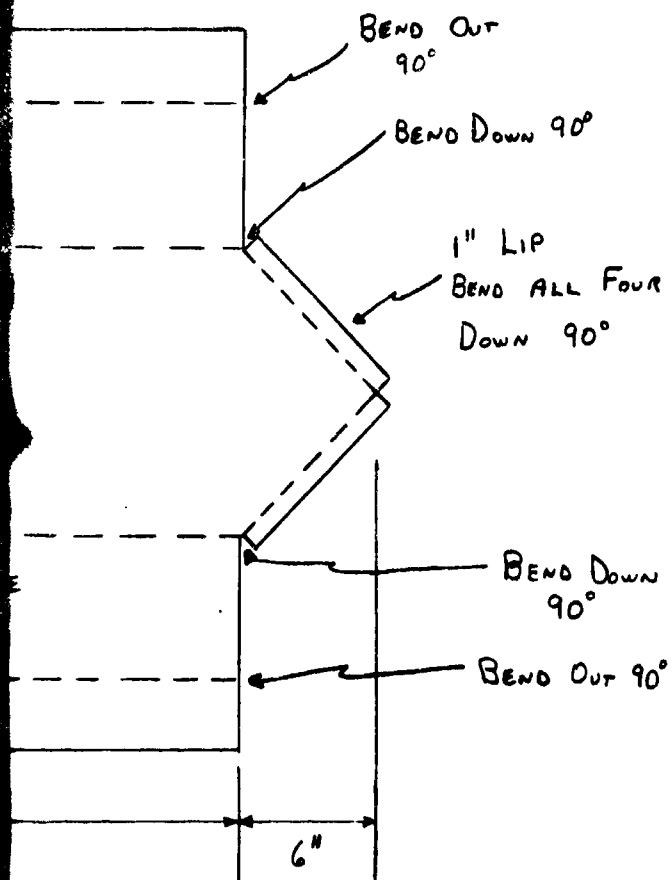

4. ON GI ONLY, AT INDICATED LOCATION, PUNCH THE FOLLOWING HOLE

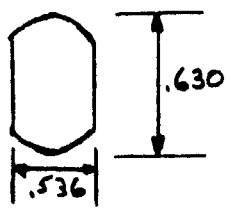

Figure A-143. ILS Ground Plane Bending Diagram (CX2205294)

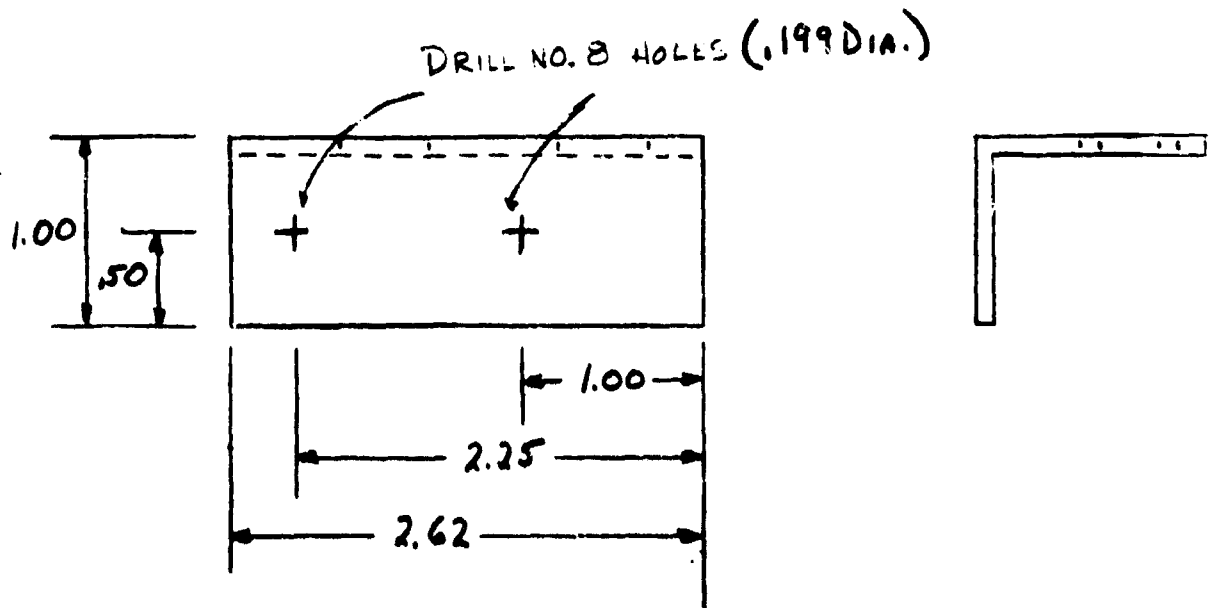
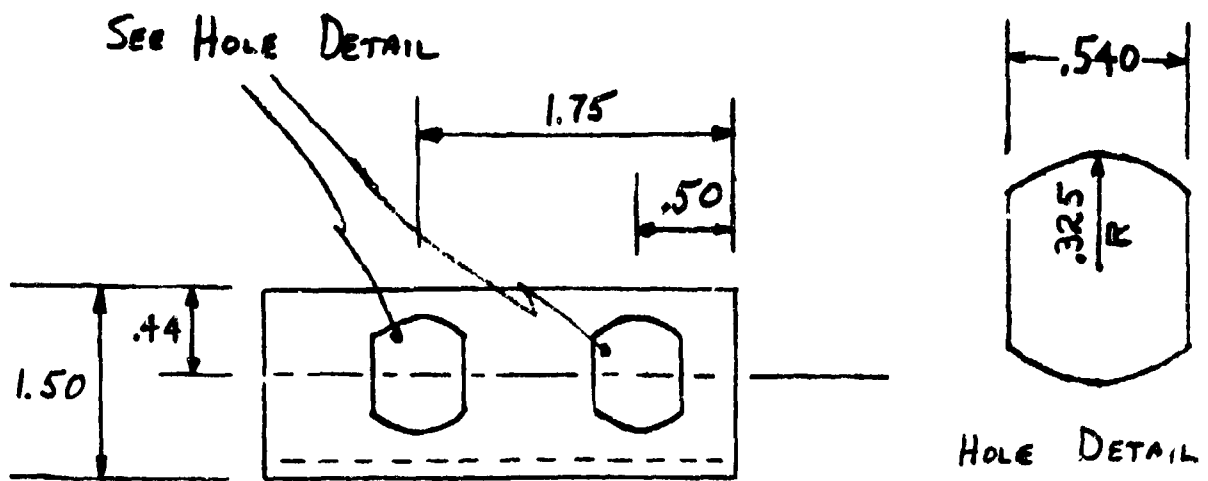

Figure A-144. Connector Mounting Bracket (BX2205297)

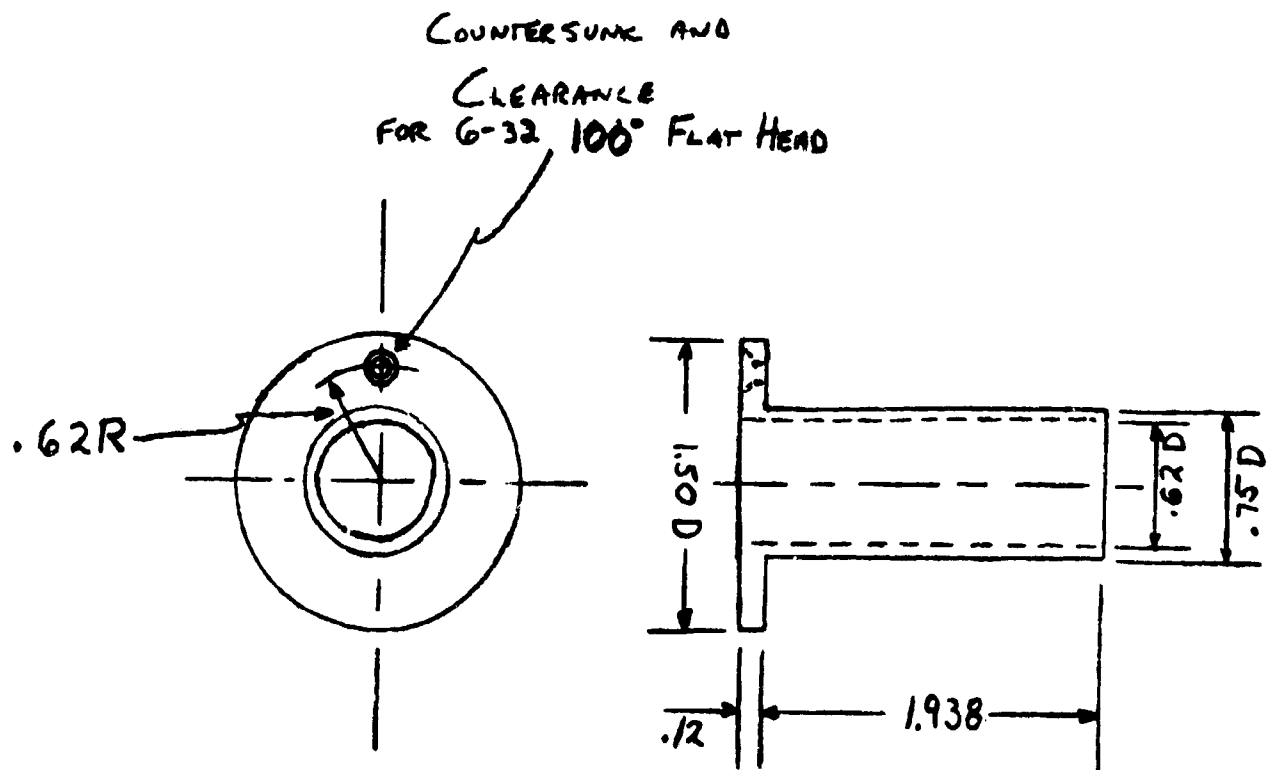

Figure A-145. Sleeve, Mounting (BX2205298)

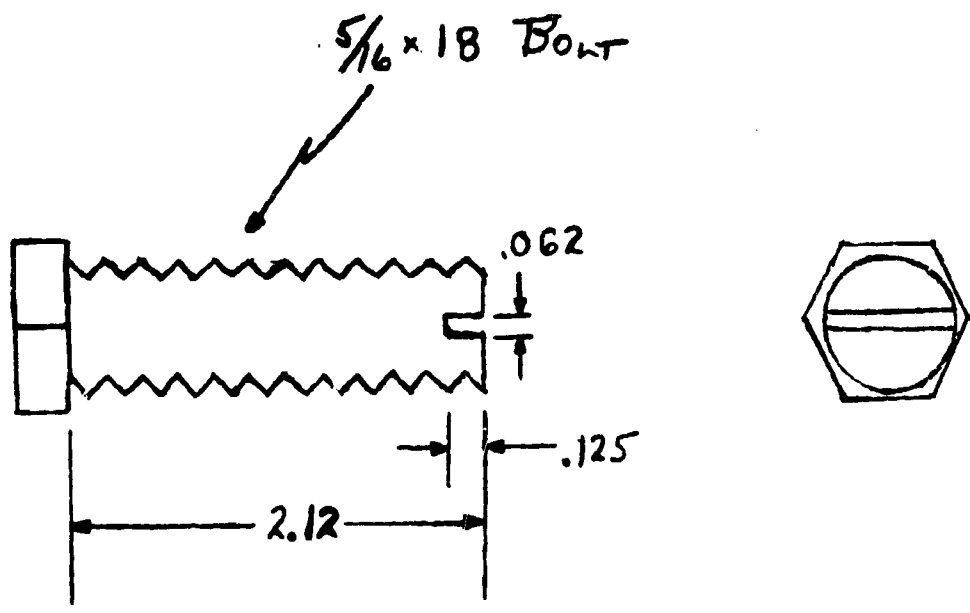
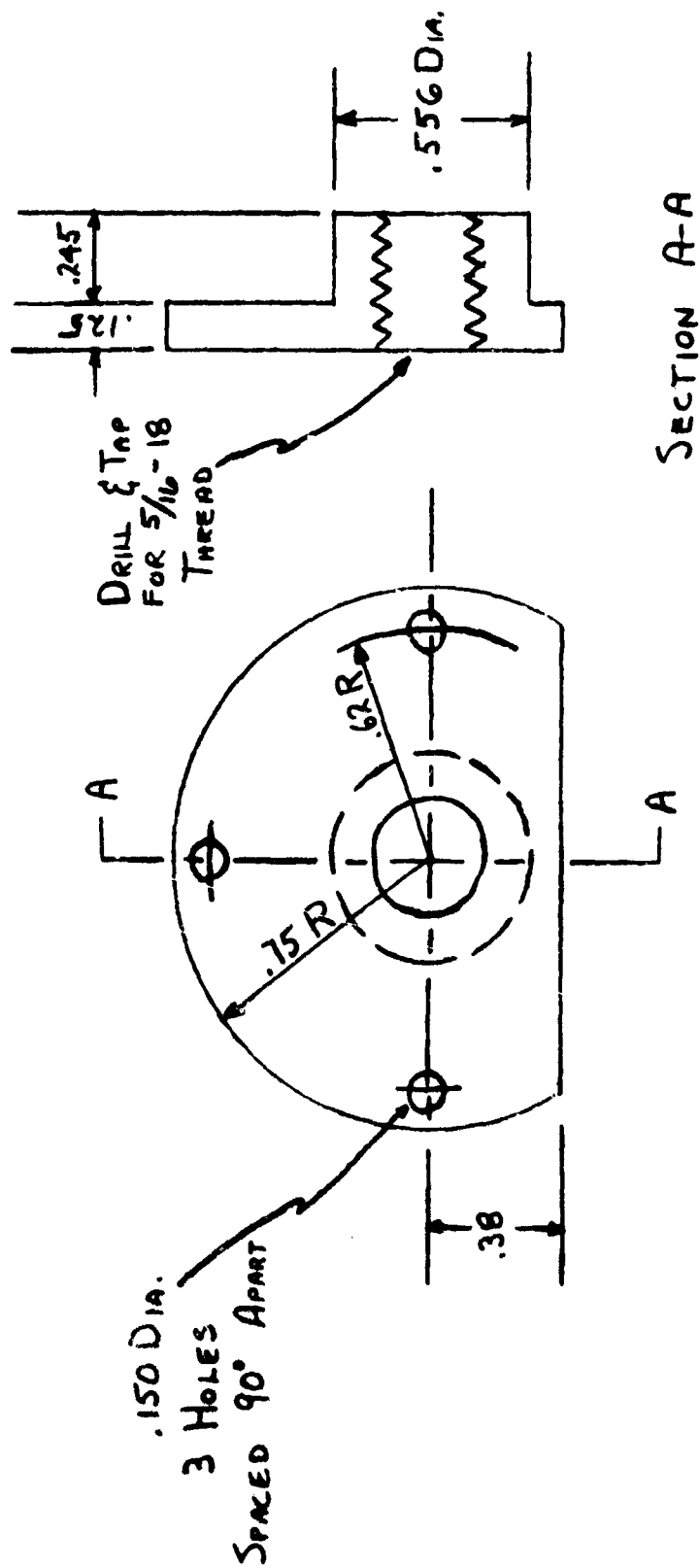

Figure A-146. Screw, Modified (BX2205302)



A-158

Figure A-147. Insulating Spacer (BX2205303)

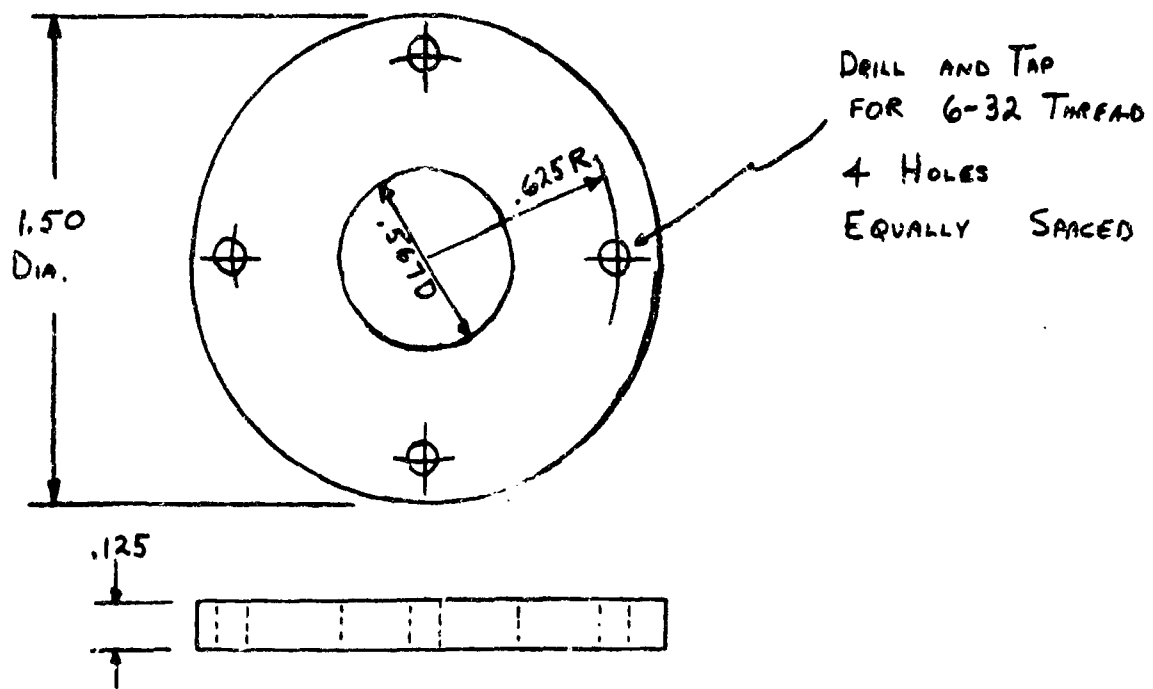

Figure A-148. Conducting Spacer (BX2205304)

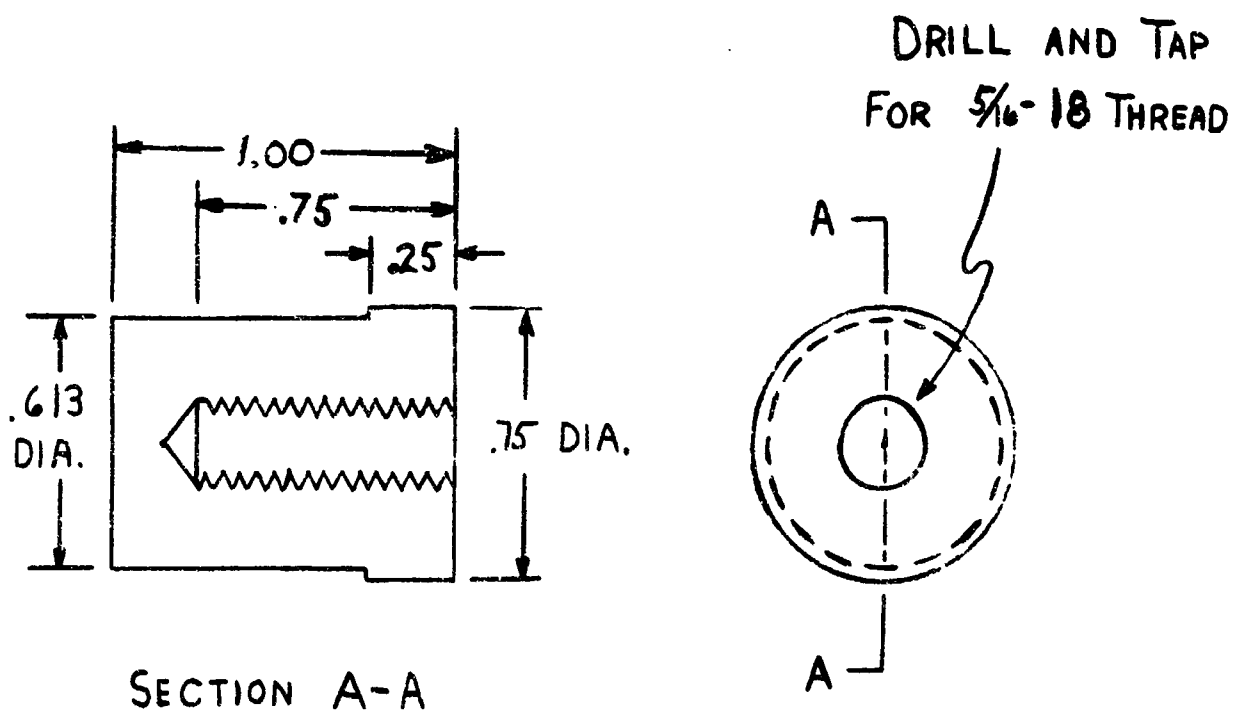

Figure A-149. Threaded Plug (BX2205305)

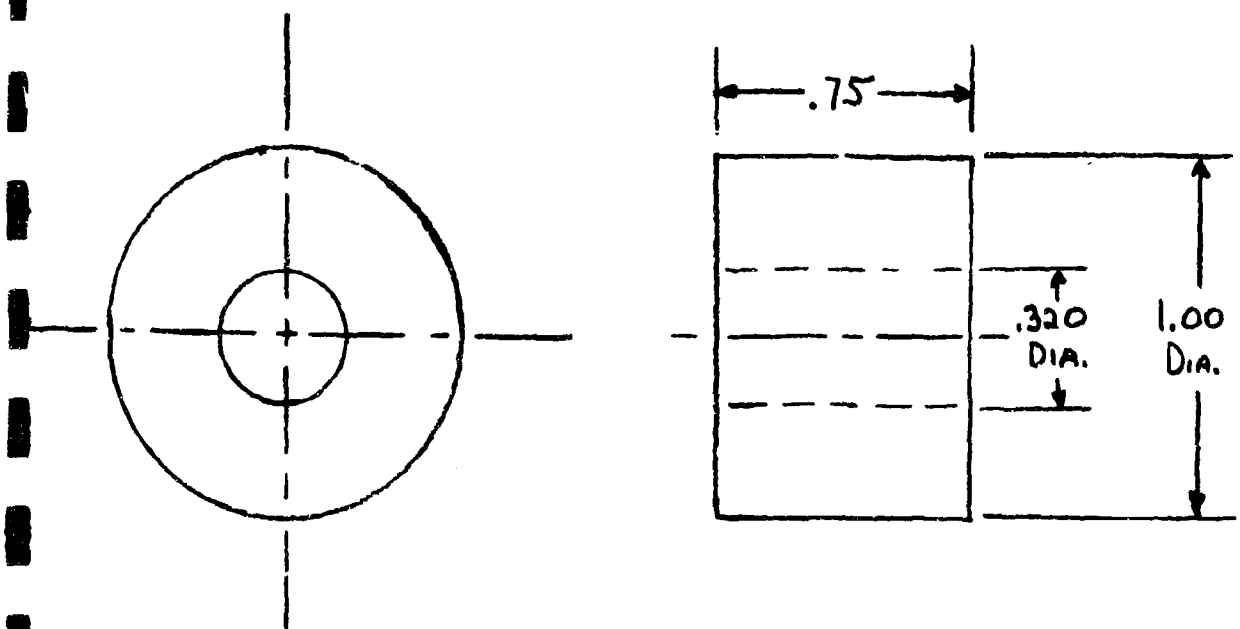
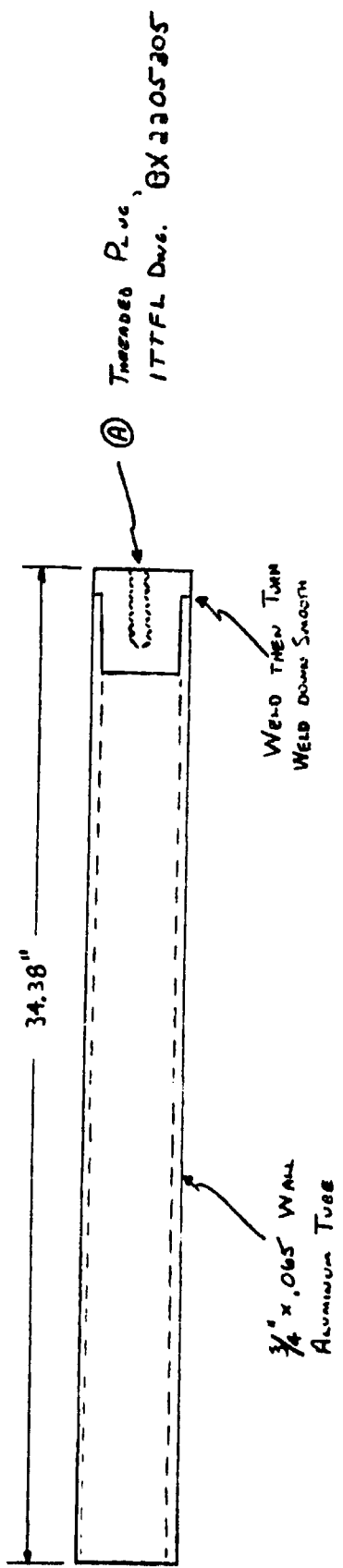

Figure A-150. Insulator (BX2205307)

A-161



FINISH: PAINTED INTERNATIONAL ORANGE

Figure A-151. Element, Transmitting (BX2205308)

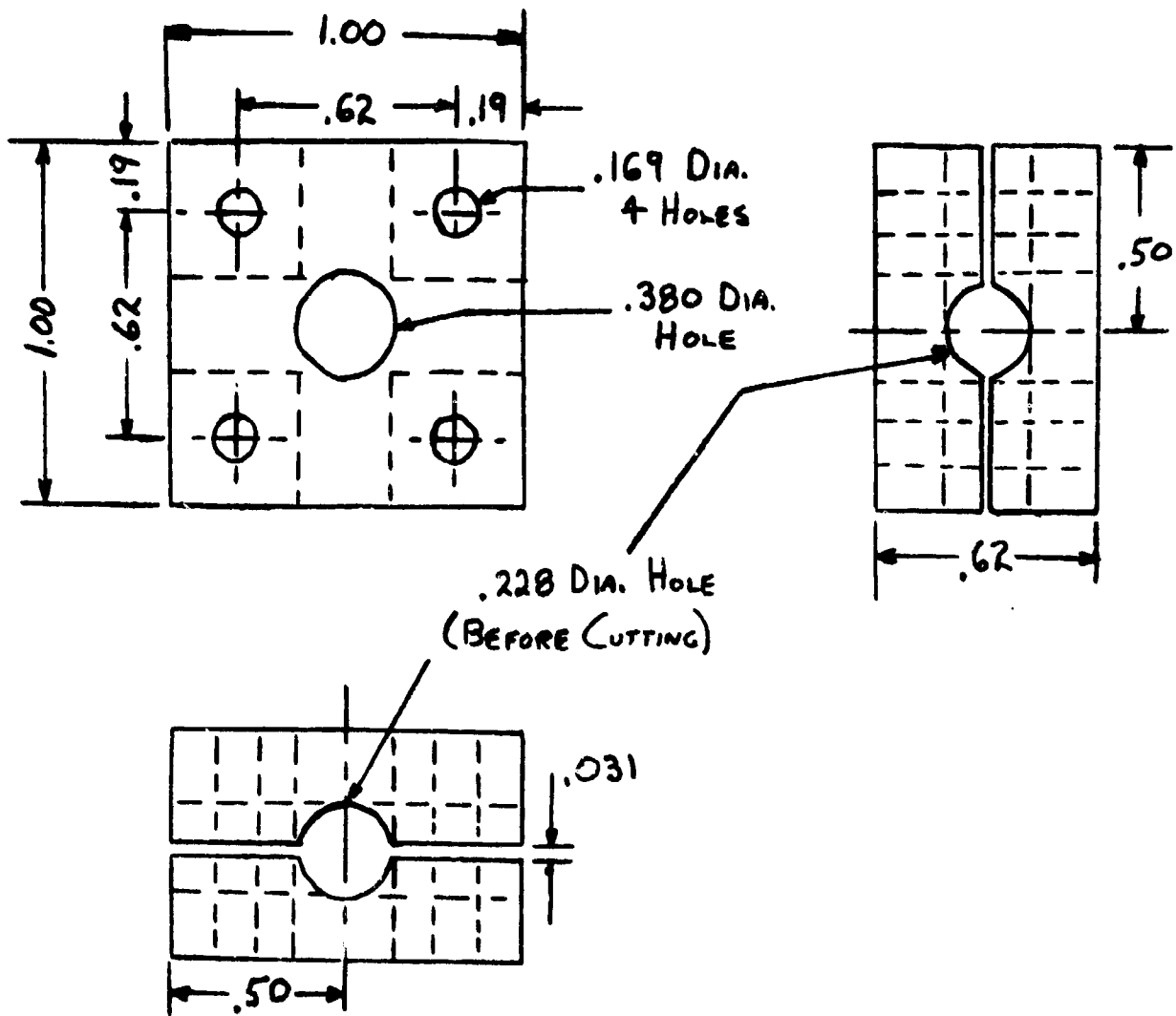
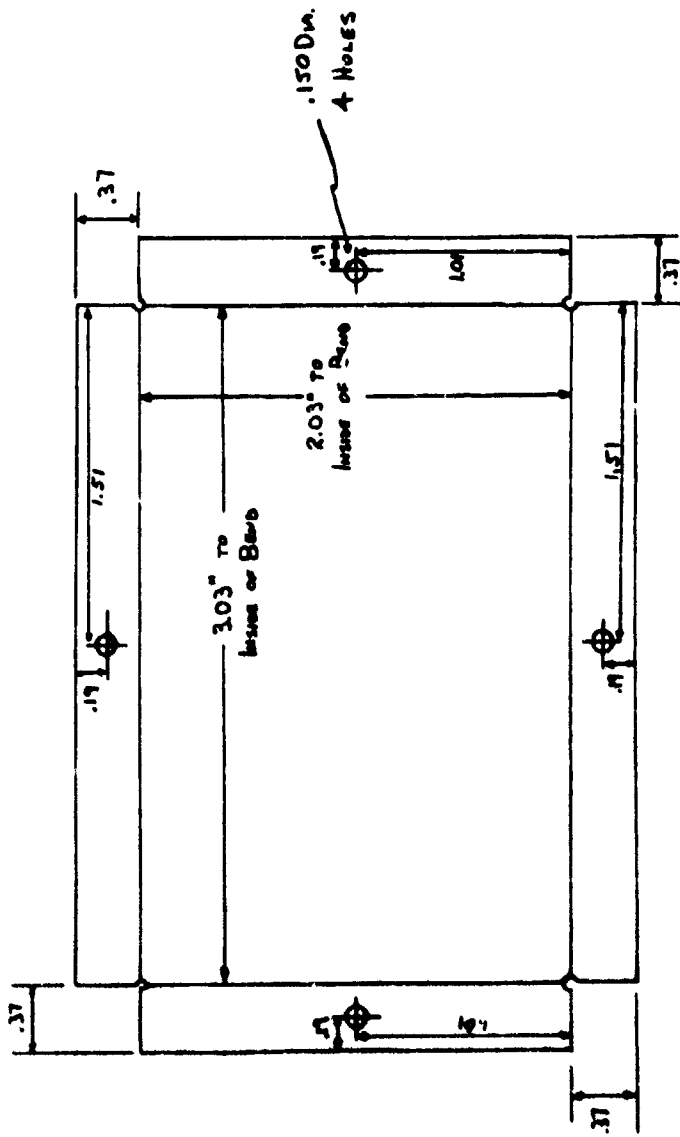

Figure A-152. Cable Clamp, Tee (BX2205310)



- NOTES: 1. BEBND ALL FOUR LIPS
DOWN 90°
2. MATERIAL: .031" ALUMINUM
 3. FINISH: PAINTED INTERNATIONAL ORANGE

A-164

Figure A-153. Cover Plate (BX2205311)

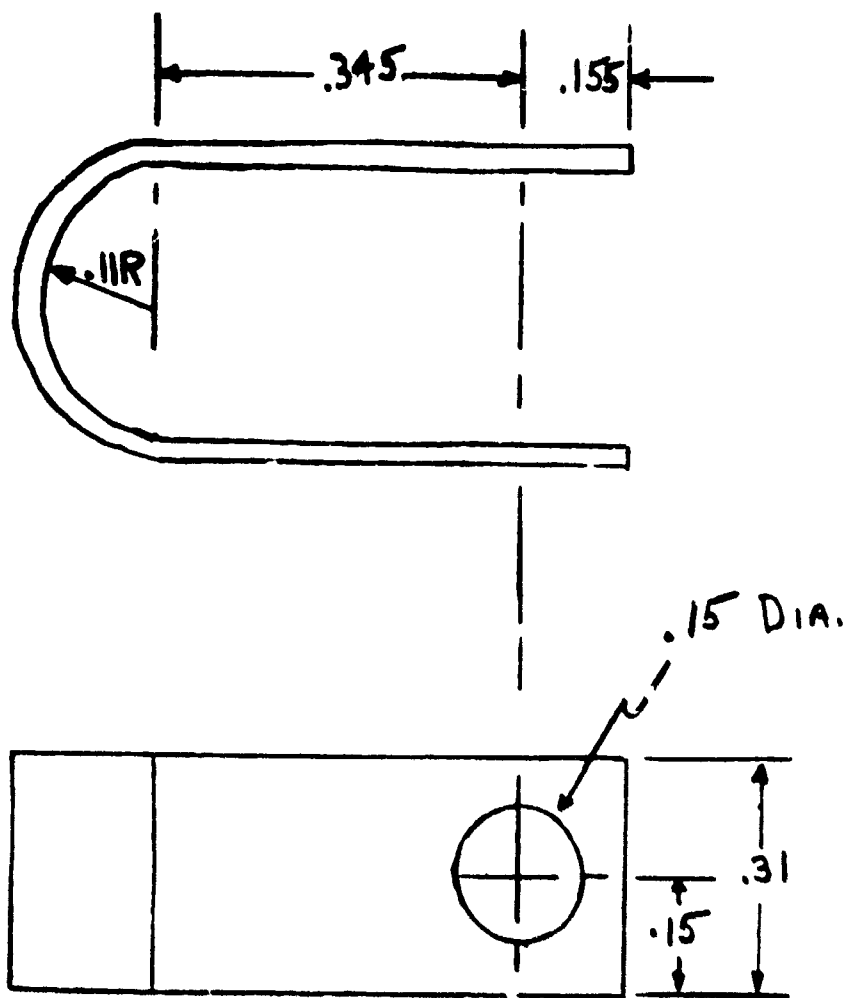
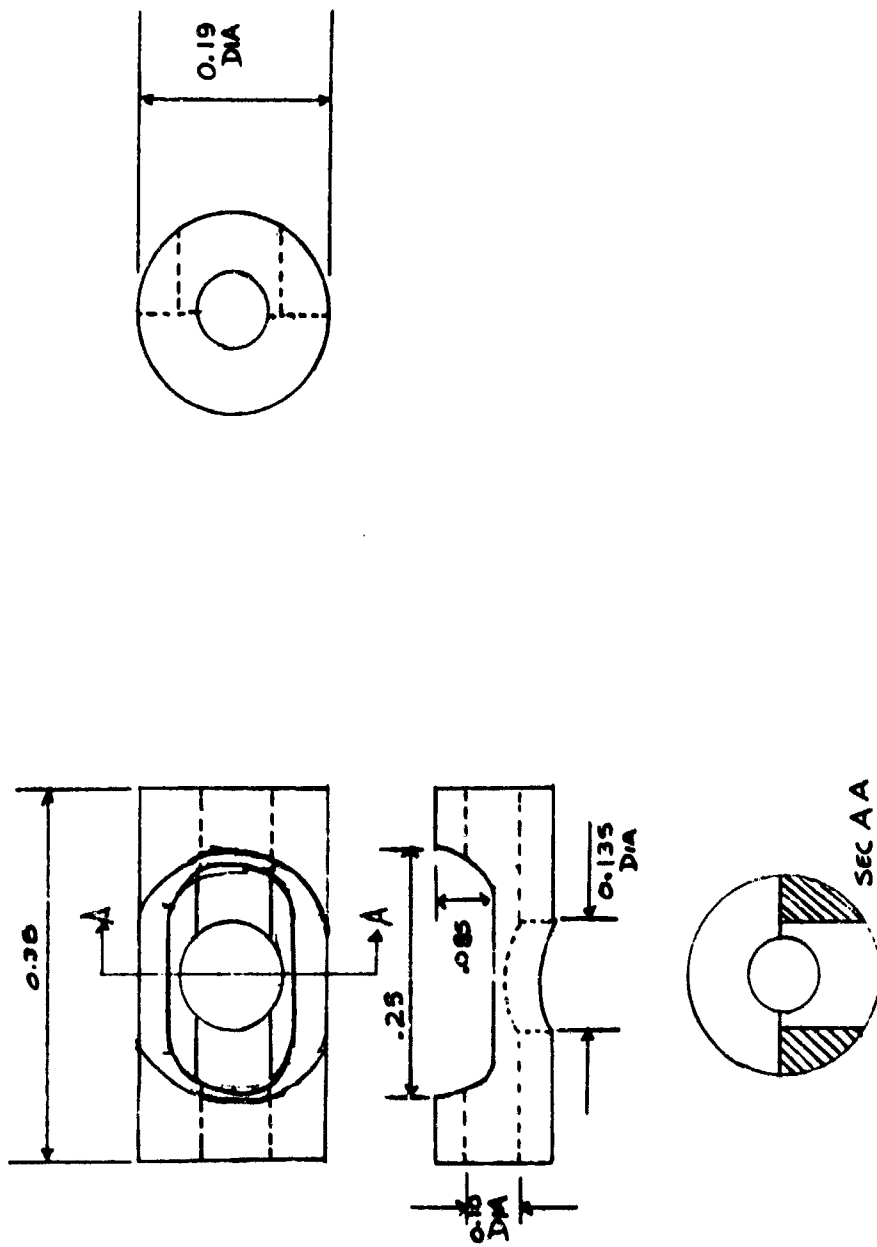

Figure A-154. Clamp Grounding (BX2205312)



MATERIAL: BRASS
FINISH: NONE

A-166

Figure A-155. Center Conductor Connector (BX2205313)

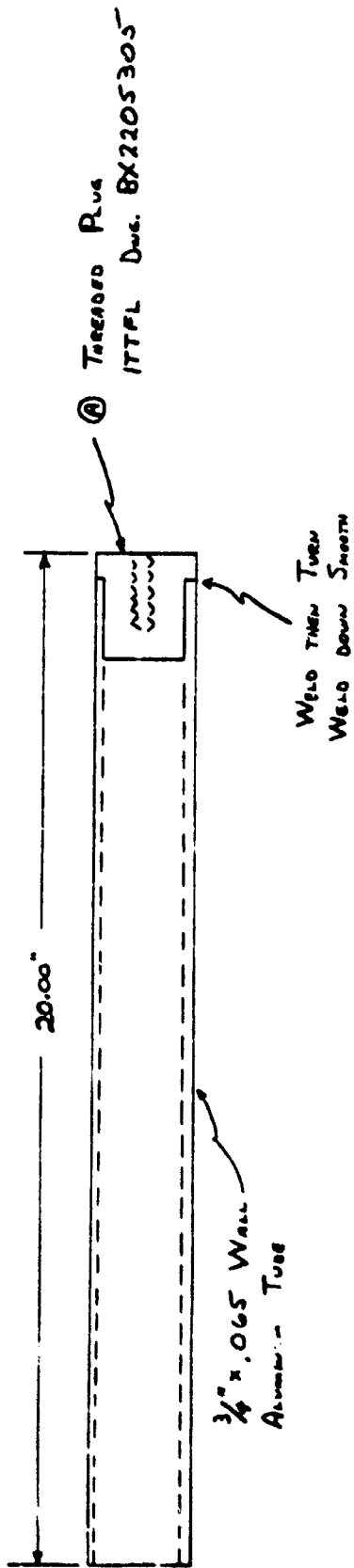

Finish: Painted International Orange

A-167

Figure A-156. Element, Monitor (BX2205314)

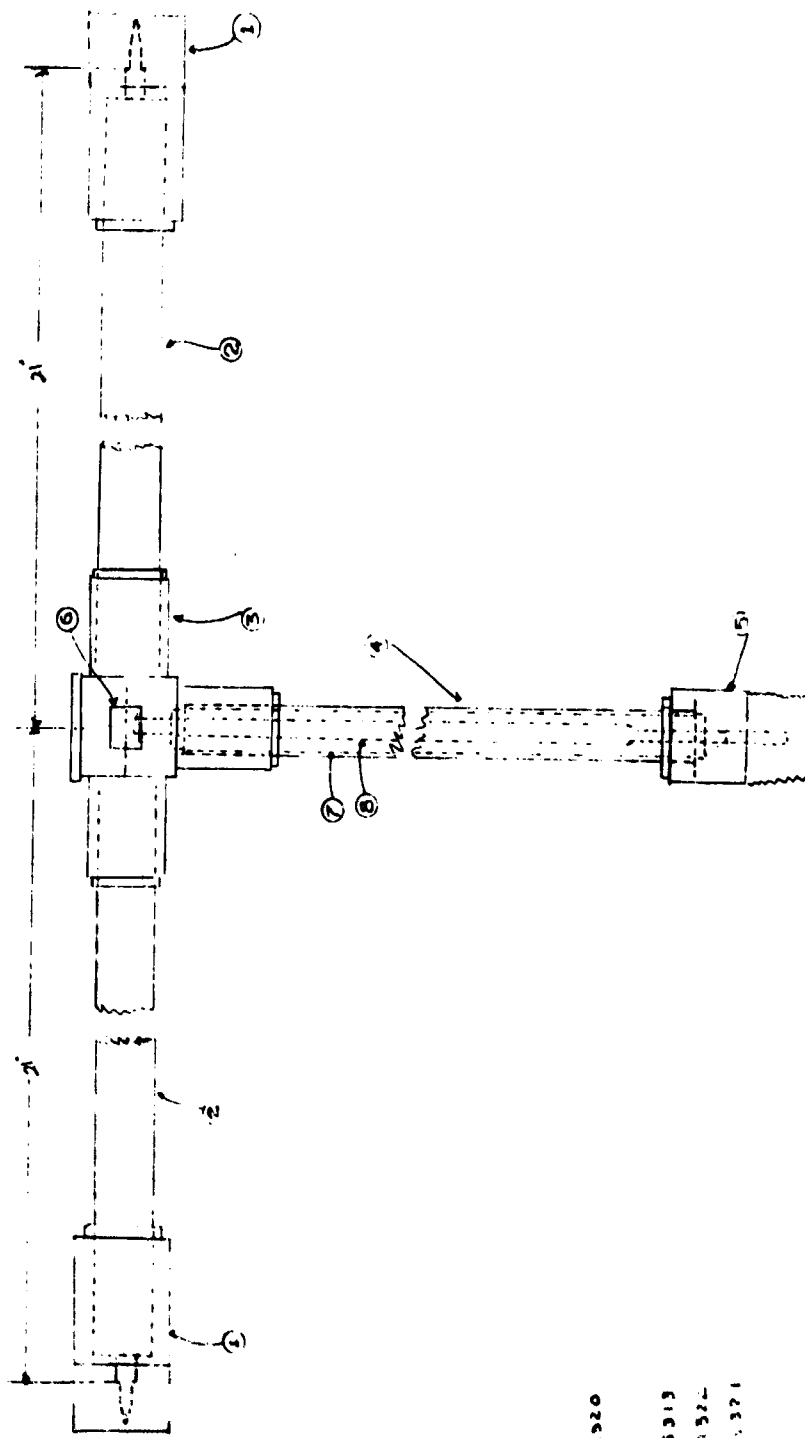

REELS

- ① UG 216/U
- ② GS 214/U
- ③ 14C RD-6250
- ④ 177 ORCA NO. 852367520
- ⑤ UG 160 A/U
- ⑥ 177 DEW MS 852205313
- ⑦ 177 DEW MS 662367322
- ⑧ 177 DEW MS 852367371

Figure A-157. Matching Network (CX2205317)

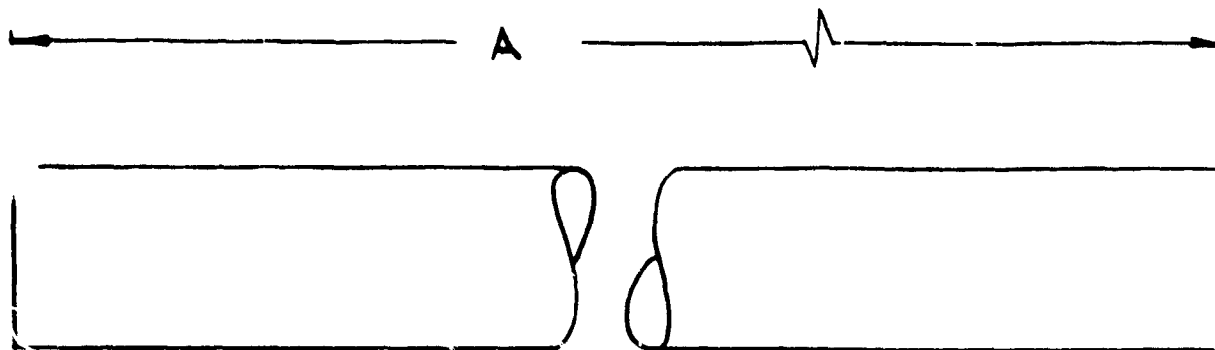

| PART NO | A |
|------------|-------|
| 2157307 G1 | 8.688 |
| G2 | 8.875 |

Figure A-158. Tube, Feed (BX2157307)

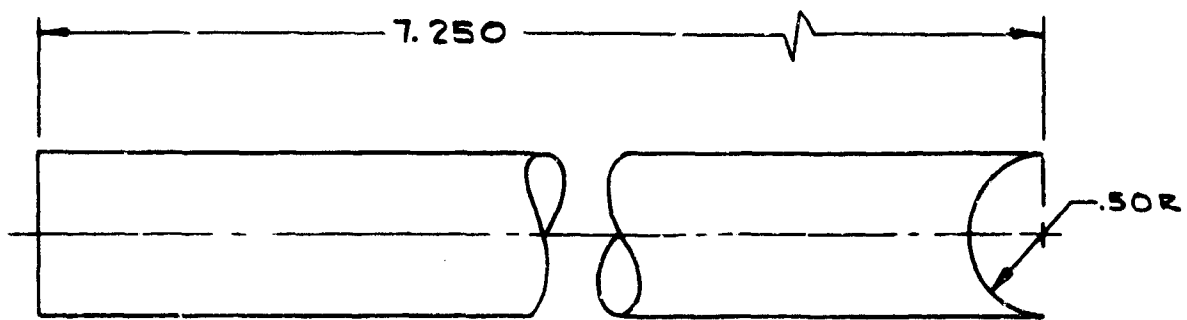
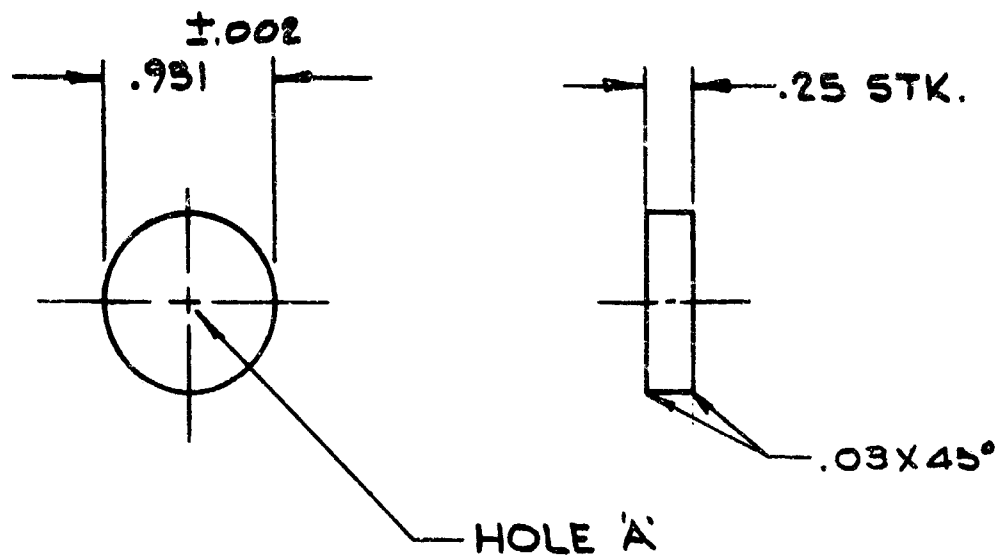

Figure A-159. Tube, Dipole (BX2157308)

A-170



| PART NO | HOLE A |
|------------|-----------------|
| 2157309 G1 | .377 $\pm .001$ |
| G2 | #8-32 TAP |
| G3 | OMIT |

Figure A-160. Cap, End (BX2157309)

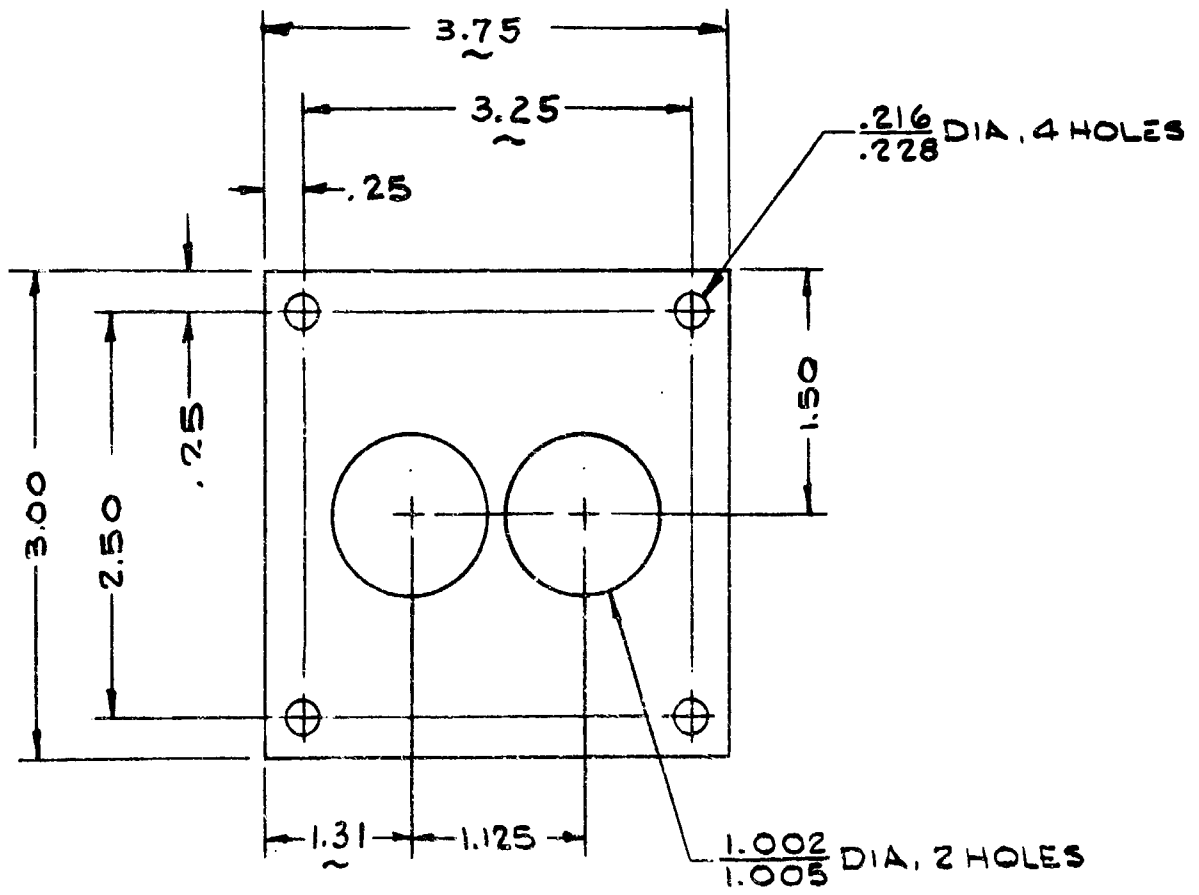

Figure A-161. Plate, MTG (BX2157310)

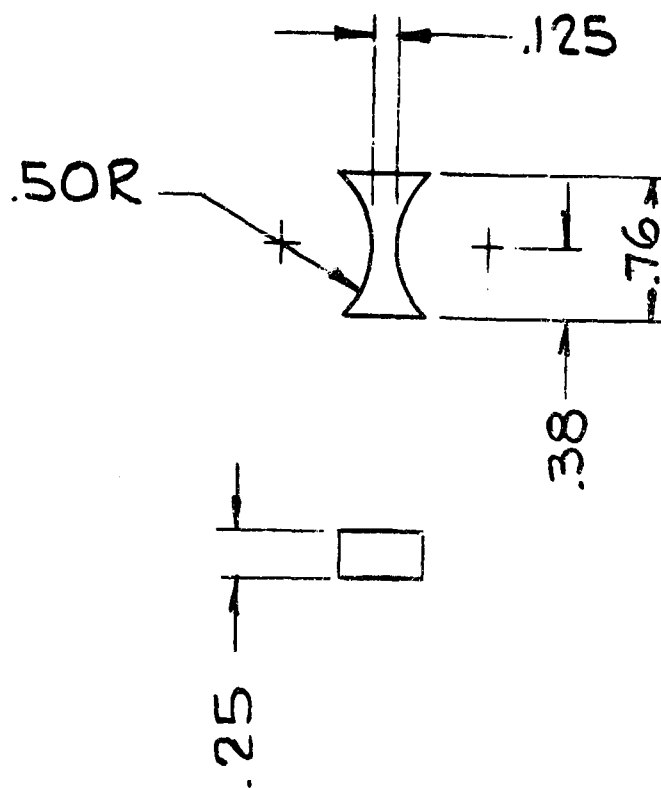
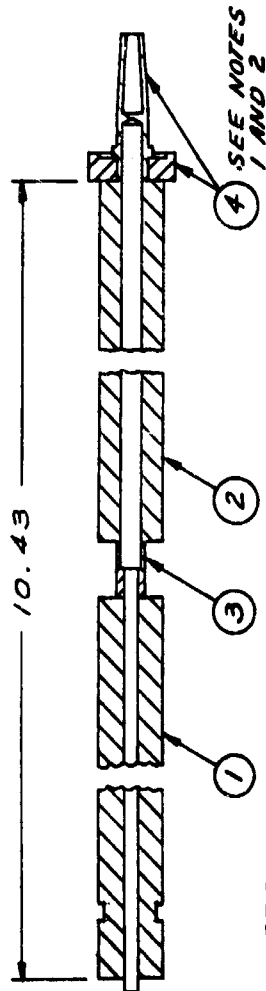

Figure A-162. Spacer (BX2157311)

A-173



- NOTES:**
1. PARTS SHOWN ARE BUSHING INSULATOR AND ELECTRICAL CONTACT WHICH ARE REMOVED FROM CONNECTOR UG-1186A/U AND USED AS SHOWN. OTHER PARTS OF CONNECTOR WILL BE USED ON FINAL ASSEMBLY.
 2. PLACE BUSHING ON CONTACT BEFORE ASSEMBLING TO ITEM 2 WITH ITEM 5. ASSEMBLE ITEMS 1, 2 & 3 WITH ITEM 5.

| GT | ITEM NO. | CODE IDENT | PART OR IDENTIFYING NO. | SYMBOLIC OR DESCRIPTION |
|----|----------|------------|-------------------------|-----------------------------------|
| X | 20 | 5 | A12132470 | PROCESS, SOFT SOLDERING |
| X | 1 | 4 | 756253 | CONNECTOR, RF, TYPE UG-1186A/U |
| 1 | 1 | 3 | B12157324 | CENTER CONDUCTOR CONNECTOR |
| 1 | 1 | 2 | B12157325 | CABLE, RF, COAXIAL, TYPE RG-87A/U |
| 1 | 1 | 1 | B12157326 | QUARTER WAVE 2.5 OHM TRANSFORMER |

Figure A-163. Center Conductor Assembly (BX2157323)

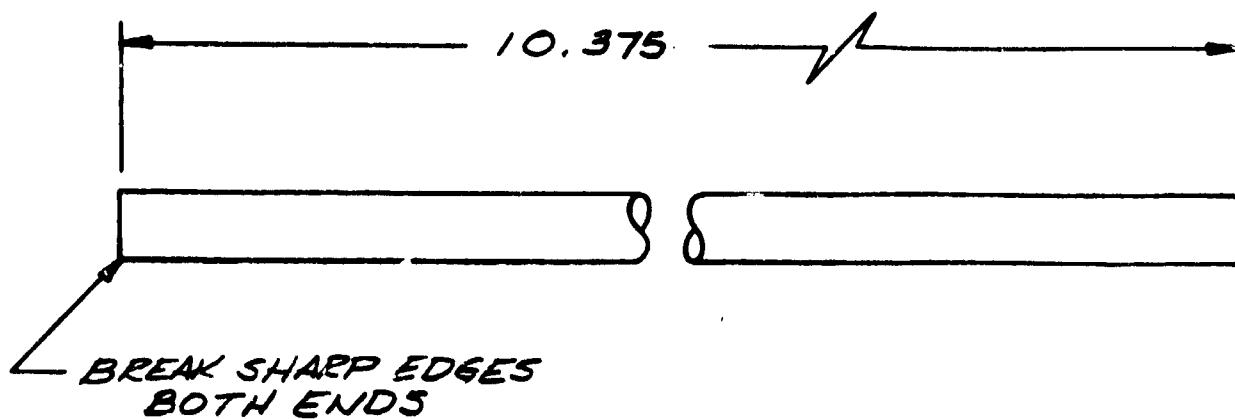

Figure A-164. Outer Conductor (BX2157327)

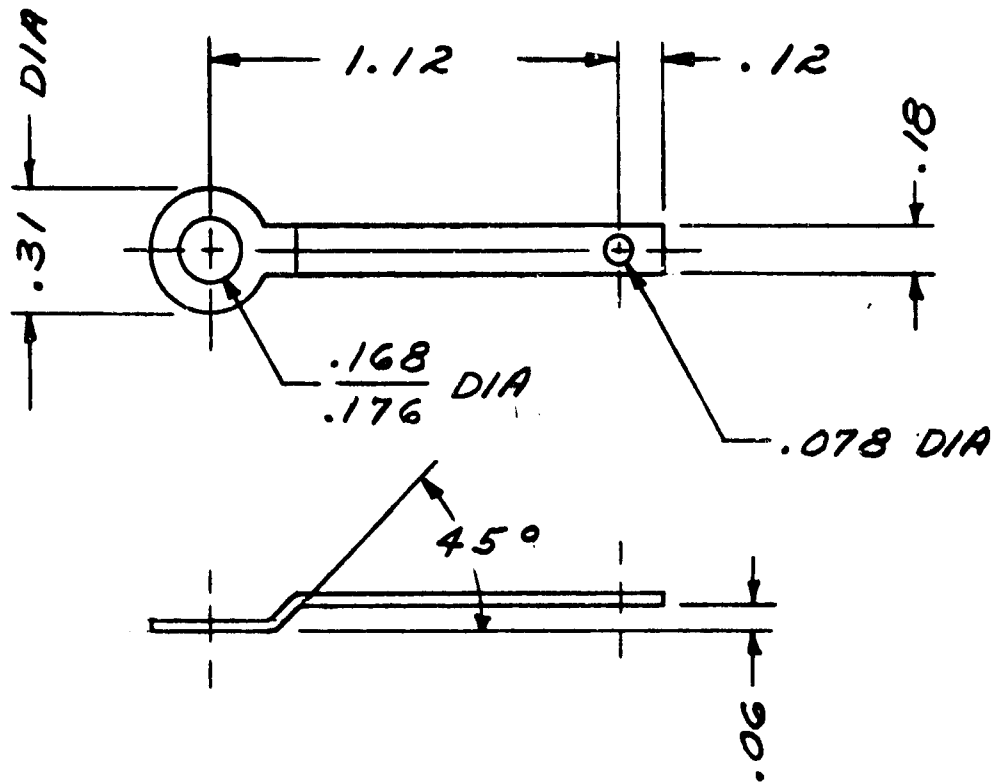
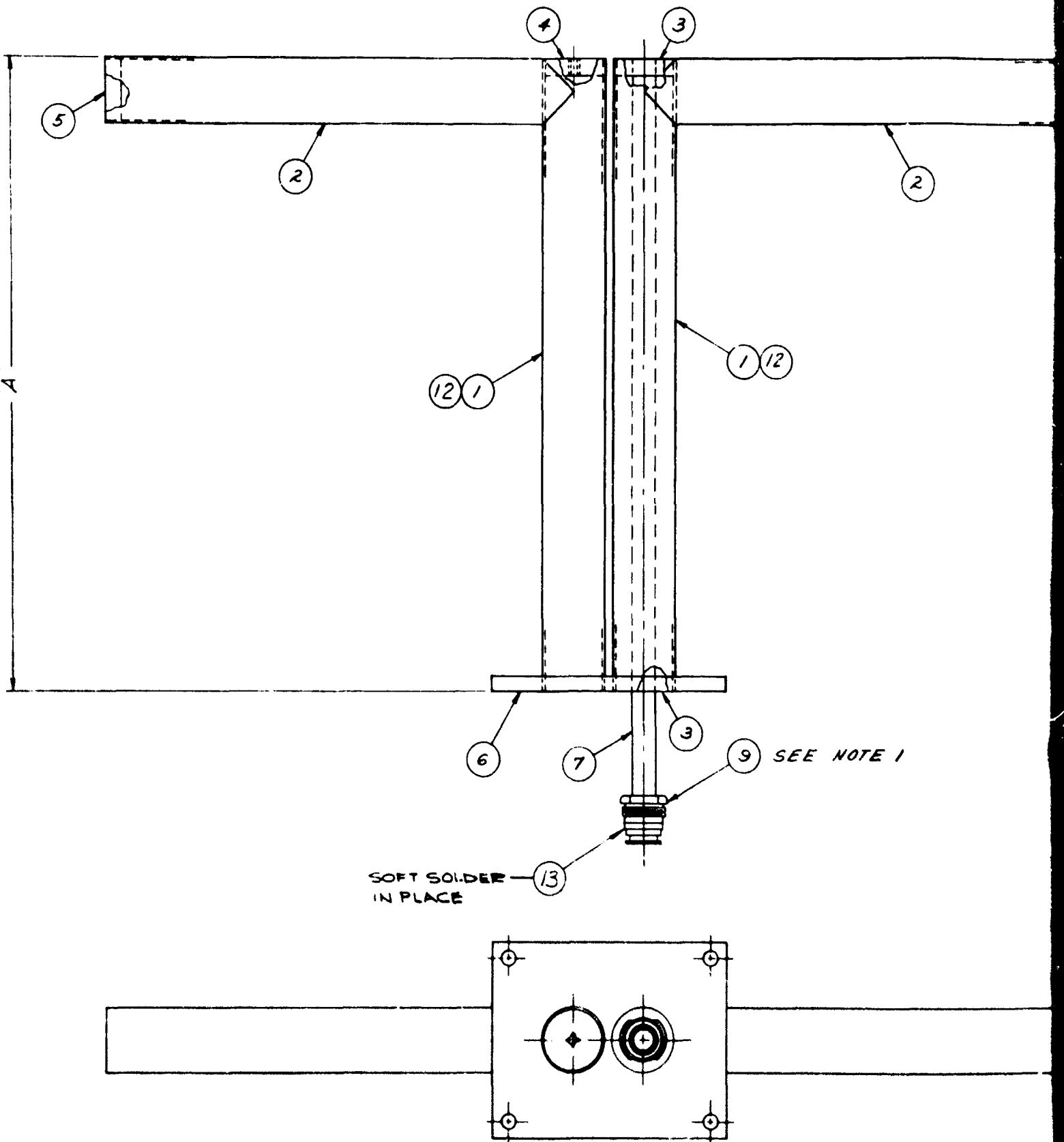

Figure A-165. Feed Point Lug (BX2157329)



A

NOTES:

1. PART SHOWN IS ELECTRICAL CABLE CLAMP WHICH IS REMOVED FROM CONNECTOR UG-1186A/U AND USED AS SHOWN. OTHER PARTS OF CONNECTOR USED ON FINAL ASSEMBLY.
2. ASSEMBLE ITEMS 3,4,5,7,8 & 9 WITH ITEM 11.
3. ASSEMBLE ITEMS 1,2 & 6 WITH ITEM 10.

| | |
|-----------|-------|
| PART NO | A |
| 215733061 | B.688 |
| G2 | B.875 |

| LIST OF MATERIALS | | | | | | | |
|-------------------|----|---|---------|------------|------|------------------------|--------------------------------|
| G2 | G1 | U | ITEM NO | CODE IDENT | SIZE | PART OR IDENTIFYING NO | NOMENCLATURE OR DESCRIPTION |
| 1 | 1 | 1 | 13 | | | B 215 7344 | SEAL, CONDUCTOR |
| 2 | - | 1 | 12 | | | B 215730762 | TUBE FEED |
| | | | 20 | 11 | | A 2152470 | PROCESS, SOFT SOLDERING |
| | | | 20 | 10 | | A 2132437 | PROCESS, SILVER SOLDERING |
| | | | 13 | | | 756253 | CONNECTOR, RF, TYPE UG-1186A/U |
| | | | | | | B 215733061 | SEAL, CONDUCTOR |
| 1 | 1 | 1 | 7 | | | B 2157327 | OUTER CONDUCTOR |
| 1 | 1 | 1 | 6 | | | B 2157310 | PLATE, MFG |
| 2 | 2 | 1 | 5 | | | B 215730563 | CAP, END |
| 1 | 1 | 1 | 4 | | | B 215730342 | CAP, END |
| 2 | 2 | 1 | 3 | | | B 215730361 | CAP, END |
| 2 | 2 | 1 | 2 | | | B 215 7300 | TUBE, DIPOLE |
| - | 2 | 1 | 1 | | | B 215730761 | TUBE, FEED |

Figure A-166. Dipole Soldering Assembly (DX2157330)

B

A-177

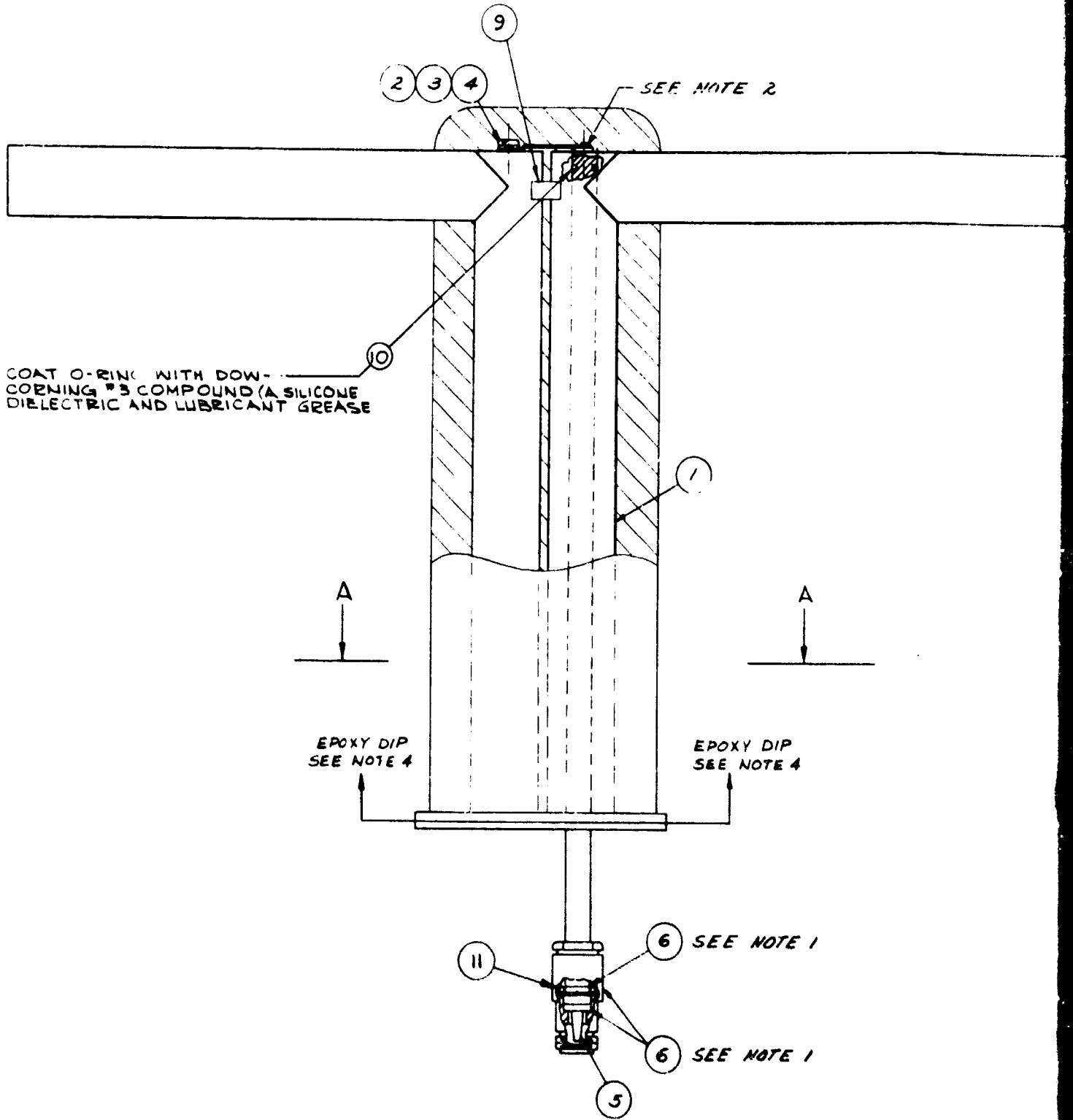

A

NOTES:

1. PARTS SHOWN ARE ~~SOLDERING WASHER~~, BUSHING INSULATOR AND ELECTRICAL CONNECTOR SHELL WHICH ARE USED FROM CONNECTOR UG-1186A/U. SEE DWG D2157330 & B2157323 FOR OTHER PARTS OF CONNECTOR USED.
2. ASSEMBLE ITEMS 4 & 5 WITH ITEM 7.
3. ENCAPSULATE WITH FOAM POLYURETHANE EQUIVALENT TO HETROFOAM 190/191 MANUFACTURED BY DUPEZ PLASTICS DIVISION, HOOKER CHEMICAL CORP, NORTH TONAWANDA, N.Y.
4. ENTIRE ENCAPSULATED ELEMENT TO BE DIPPED IN EPOXY TO BASE PLATE. WHITE PIGMENTED EPOXY TO BE USED TO GIVE OPAQUE WHITE FINISH. (CONT'D)



SEE NOTE 3

NOTE 4 (CONT'D)

EPOXY COAT TO BE NOT LESS THAN 1/64" THICKNESS AND SHALL BRIDGE AND FILL ANY VOIDS BETWEEN ENCAPSULATION AND THE ELEMENT.

| LIST OF MATERIALS | | | | | | | |
|-------------------|---|---|---------|------------|-----|------------------------|--------------------------------------|
| QTY | U | M | ITEM NO | CODE IDENT | QTY | PART OR IDENTIFYING NO | DESCRIPTION |
| 1 | 1 | 1 | 11 | | | | O-RING, PARKER #2-15 (COMP. N109-7) |
| 1 | 1 | 1 | 10 | | | | O-RING, PARKER #5-104 (COMP. N109-7) |
| 1 | 1 | 1 | 9 | | B | 2157311 | SPACE |
| 1 | 1 | 1 | 8 | | D | 2157306? | DIPOLE ASSEMBLY SOLDERING |
| 1 | 1 | 1 | 7 | | A | 2152410 | PROCESS. SOFT SOLDERING |
| 1 | 1 | 1 | 6 | | | 756253 | CONNECTOR, RF, TYPE UG-1186A/U |
| 1 | 1 | 1 | 5 | | B | 2.57323 | CENTER CONDUCTOR ASSEMBLY |
| 1 | 1 | 1 | 4 | | B | 2157323 | FEED POINT LUG |
| 1 | 1 | 1 | 3 | | | 107202 | WASHER, LOCK W. B |
| 1 | 1 | 1 | 2 | | | 100608116 | SCREW, MACHINE, 8-32 x 1/2 |
| 1 | 1 | 1 | 1 | | D | 21573061 | DIPOLE ASSEMBLY, SOLDERING |

Figure A-167. ILS Glide Slope Dipole (DX2157331)

B

A-178

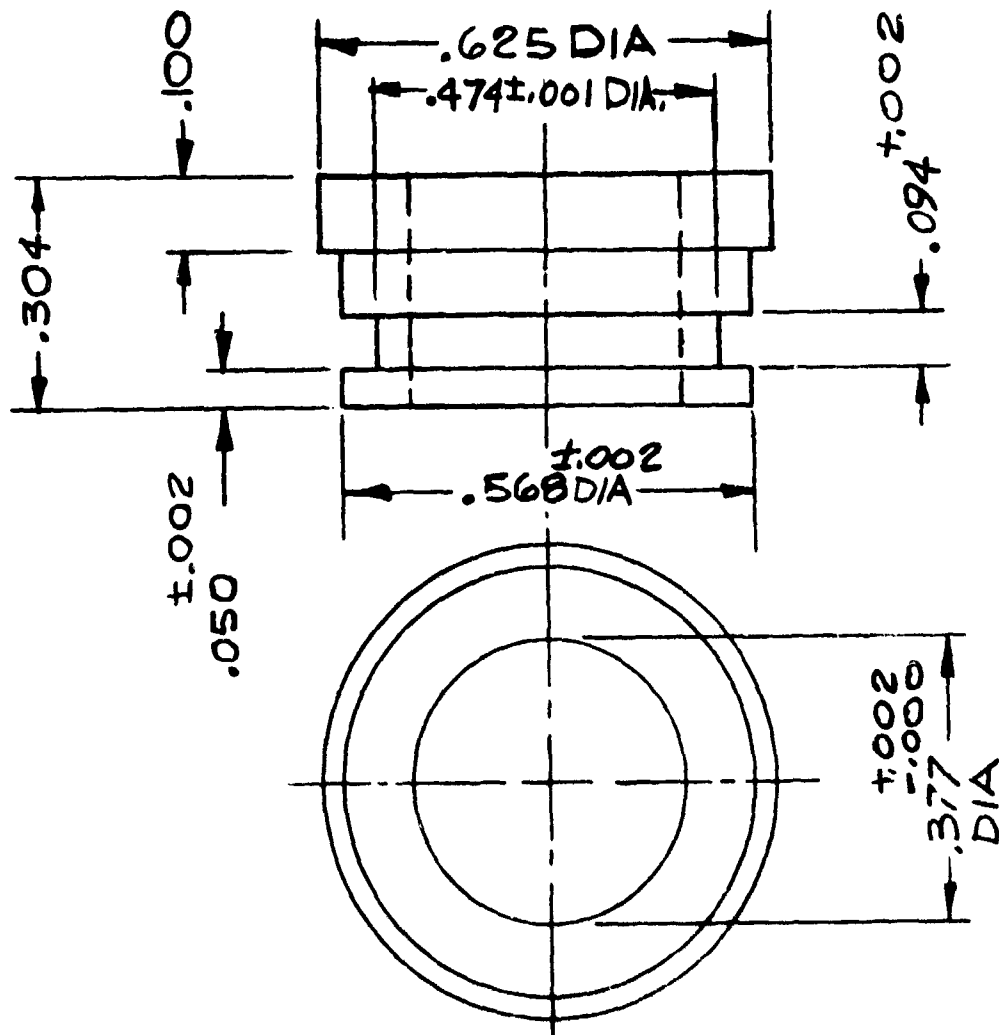
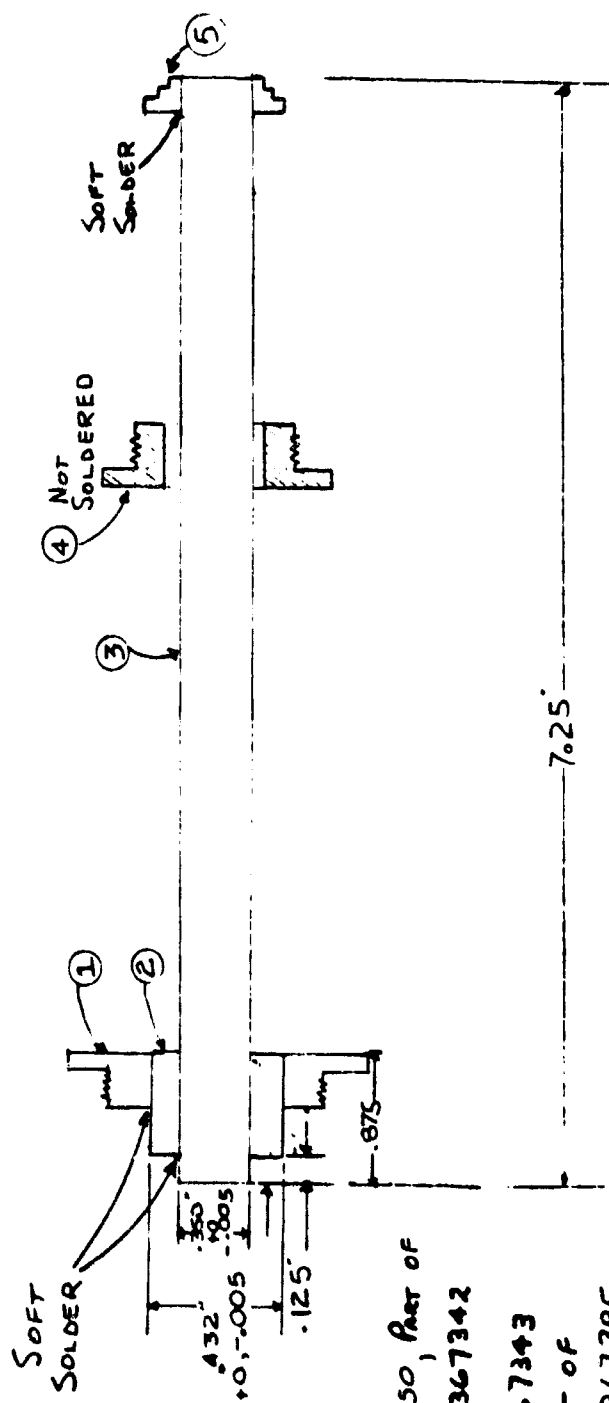

Figure A-168. Seal, Connector (BX2157344)



- ① - IRC COMB No 6250, PART OF
- ② - BUSHING, AX 2367342
- ③ - TUBE, AX 2367343
- ④ - UG-160, PART OF
- ⑤ - BUSHING, AX 2367385

FINISH: TAPE LOOSE PART OF CONNECTOR TO END WITH ITEM 5
AND PAINT EXPOSED PART OF TUBE BETWEEN CONNECTORS WHITE

Figure A-169. Transformer Outer Conductor (BX2367320)

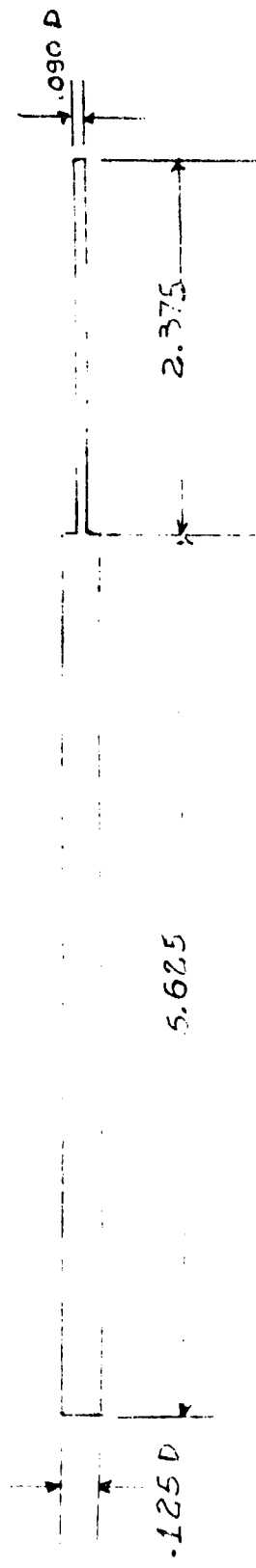

A-181

Figure A-170. Transformer Inner Conductor (BX2367321)

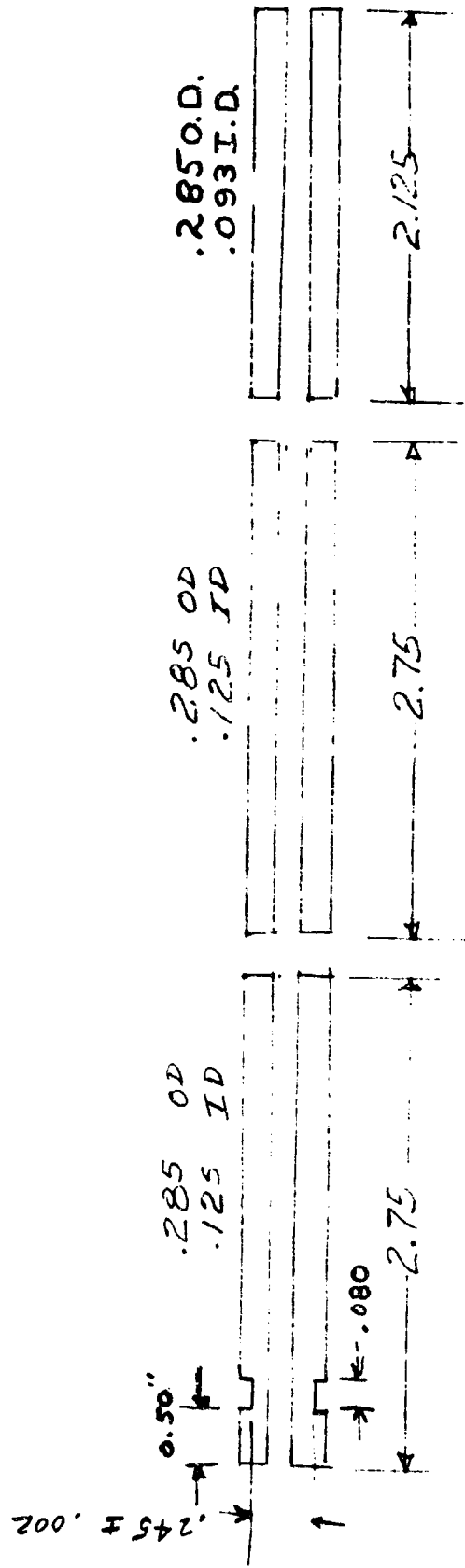

A-182

Figure A-171. Transformer, Coaxial, Dielectric (BX2367322)

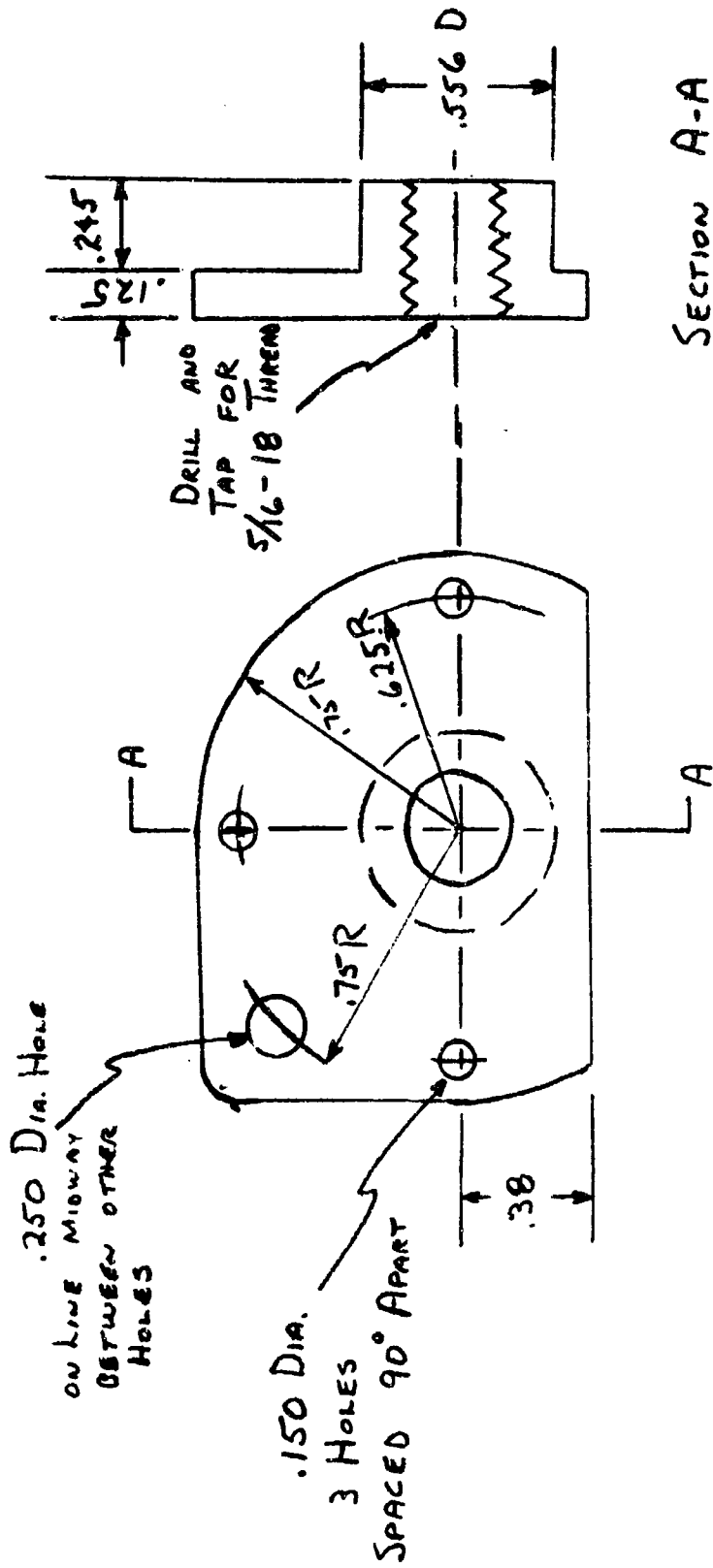

MATERIAL: TEFLON

Figure A-172. Insulating Spacer, Monitor (BX2367327)

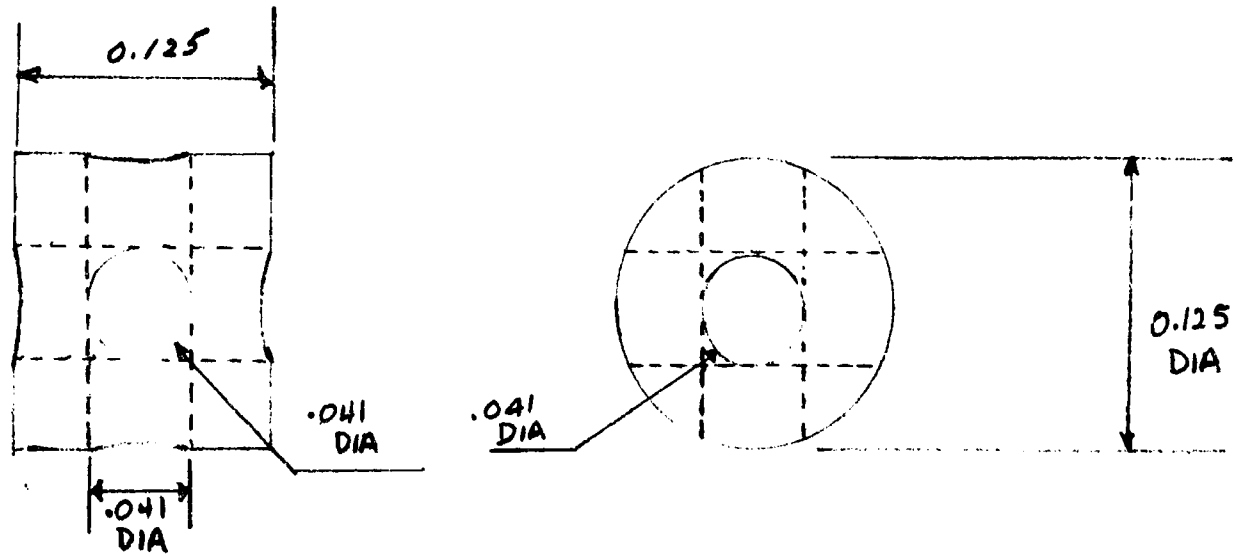

MATERIAL : .125 DIA. BRASS ROD

Figure A-173. Center Conductor Connector (Small) (BX2367328)

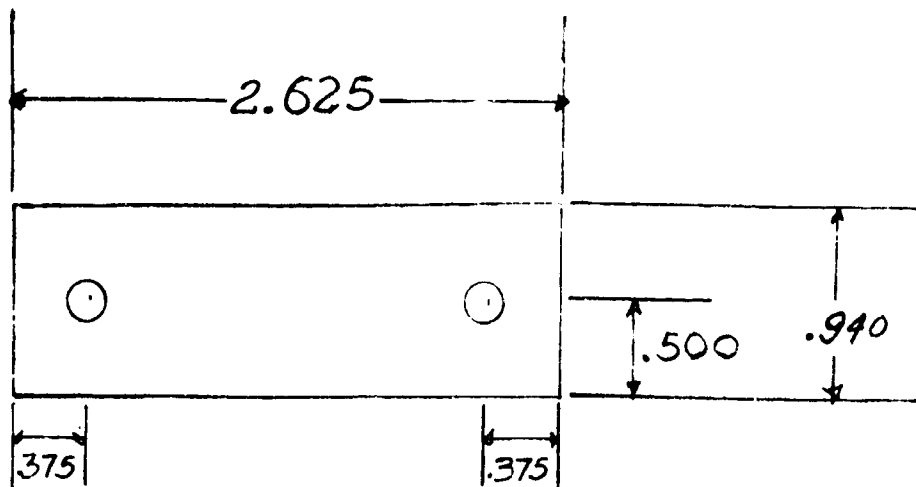

NOTE: ALL HOLES CLEARANCE
FOR #10 SCREW

Figure A-174. Grounding Plate (BX2367329)

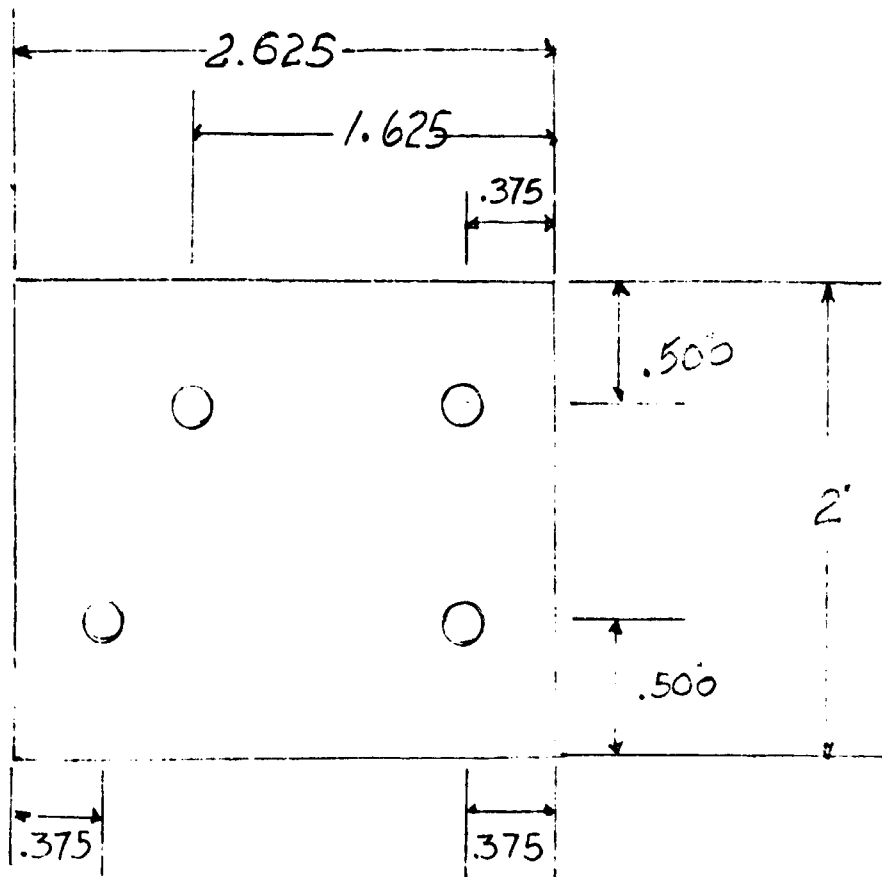

NOTE: ALL HOLES CLEARANCE FOR
10 SCREW

Figure A-175. Mounting Plate, Ground (BX2367330)

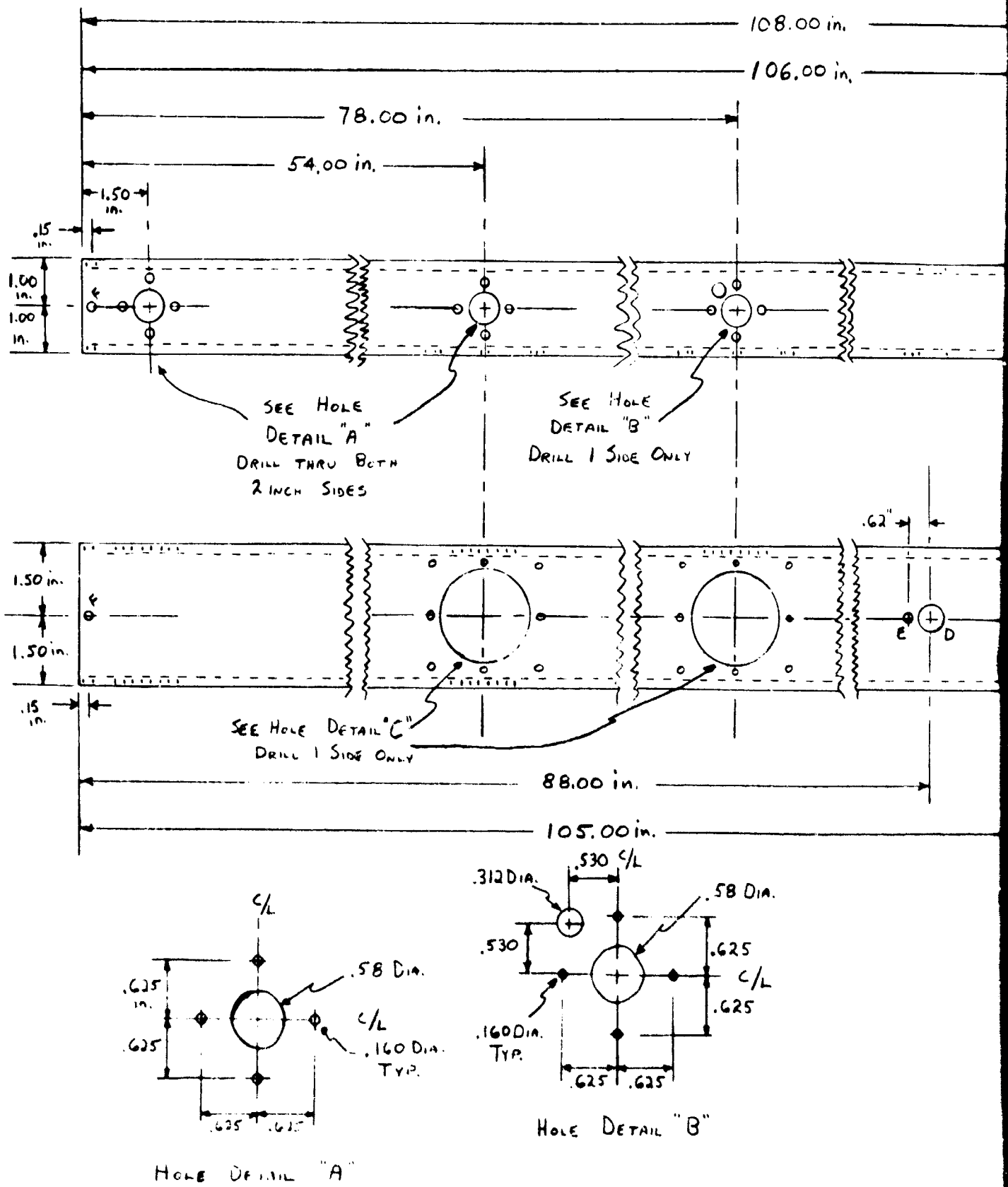

A

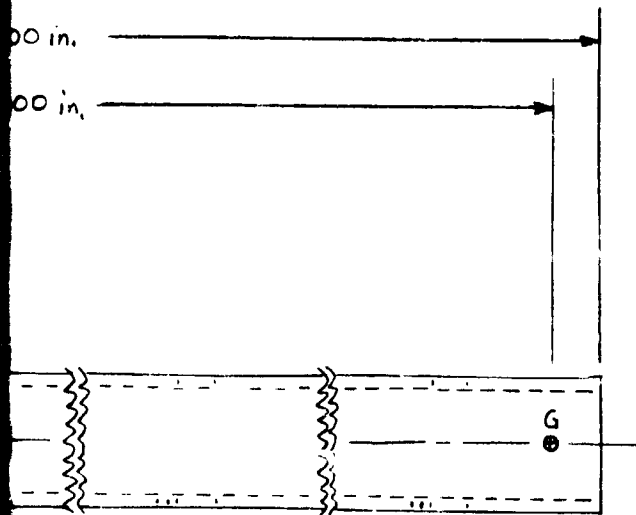

FINISH: IRIDIUM, THEN PAINT OUTSIDE ONLY AS FOLLOWS,
 1. APPLY WASH PRIMER AS PER MIL-C-1532B
 2. APPLY ZINC CHROMATE PRIMER PER MIL-P-8585
 3. APPLY FINAL COAT INTERNATIONAL ORANGE,
 COLOR SPECIFIED BY FEDERAL STANDARDS #595
 4. PLUG ALL HOLES AND ENDS BEFORE
 PAINTING.

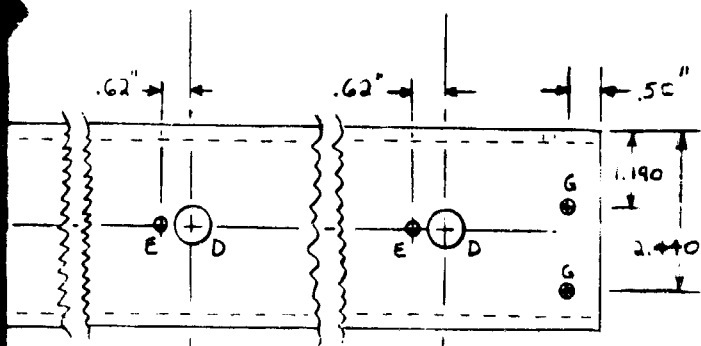

HOLE INDEX

- D. .81 DIA., THRU BOTH 3" SIDES
- E. DRILL & TAP FOR 6-32 SCREW,
ONE SIDE ONLY.
- F. .101 DIA., THRU ALL FOUR SIDES
- G. .199 DIA., THRU ONE SIDE ONLY

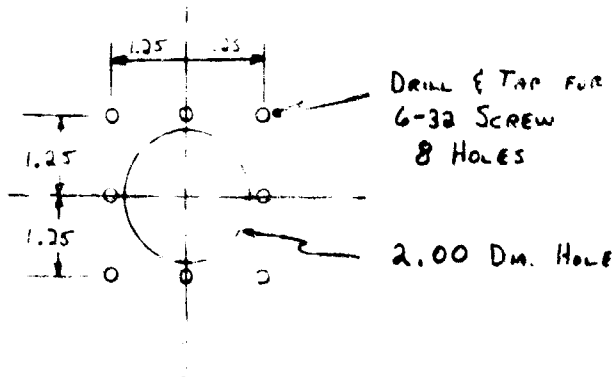

Hole Detail 'C'

Figure A-176. Support Tube (CX2367383)

B

A-187

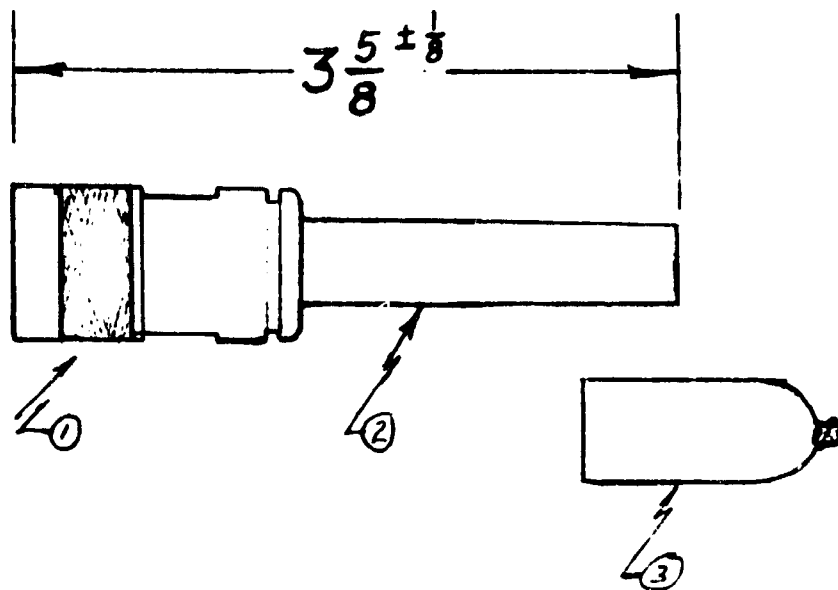

NOTES:

- A. PLACE A UG21E/U CONNECTOR ON A PIECE OF RG214 APPROX. FOUR INCHES LONG.
- B. CUT THE CABLE ELECTRICALLY TO BE 50 ± 2 DEGREES. THE FINISHED LENGTH SHOULD BE AS SHOWN ABOVE.
- C. PLACE ITEM 3 ON AND HEAT WITH A TORCH TO SHRINK. THE OPERATION SHOULD BE DONE AS FAST AS PRACTICABLE TO PREVENT MELTING THE DIELECTRIC IN THE RG214 CABLE.

| PART | DESCRIPTION |
|------|--|
| 1. | UG21E/U |
| 2. | RG214 |
| 3. | FIT CAP - SHRINKABLE ALUMINUM WIRE #4 (0.5) |

Figure A-177. Stub-Sideband Generator Input (AX2367432)