

UNCLASSIFIED

AD NUMBER	
AD501008	
CLASSIFICATION CHANGES	
TO:	unclassified
FROM:	confidential
LIMITATION CHANGES	
TO:	Approved for public release, distribution unlimited
FROM:	Distribution authorized to U.S. Gov't. agencies and their contractors; Administrative/Operational Use; 21 MAR 1969. Other requests shall be referred to Assistant Chief of Staff for Force Development [Army], Washington, DC 20310.
AUTHORITY	
AGO D/A ltr dtd 29 Apr 1980; AGO D/A ltr dtd 29 Apr 1980	

THIS PAGE IS UNCLASSIFIED

THIS REPORT HAS BEEN DELIMITED
AND CLEARED FOR PUBLIC RELEASE
UNDER DOD DIRECTIVE 5200.20 AND
NO RESTRICTIONS ARE IMPOSED UPON
ITS USE AND DISCLOSURE.

DISTRIBUTION STATEMENT A

APPROVED FOR PUBLIC RELEASE;
DISTRIBUTION UNLIMITED.

SECURITY

MARKING

The classified or limited status of this report applies to each page, unless otherwise marked.

Separate page printouts MUST be marked accordingly.

THIS DOCUMENT CONTAINS INFORMATION AFFECTING THE NATIONAL DEFENSE OF THE UNITED STATES WITHIN THE MEANING OF THE ESPIONAGE LAWS, TITLE 18, U.S.C., SECTIONS 793 AND 794. THE TRANSMISSION OR THE REVELATION OF ITS CONTENTS IN ANY MANNER TO AN UNAUTHORIZED PERSON IS PROHIBITED BY LAW.

NOTICE: When government or other drawings, specifications or other data are used for any purpose other than in connection with a definitely related government procurement operation, the U.S. Government thereby incurs no responsibility, nor any obligation whatsoever; and the fact that the Government may have formulated, furnished, or in any way supplied the said drawings, specifications, or other data is not to be regarded by implication or otherwise as in any manner licensing the holder or any other person or corporation, or conveying any rights or permission to manufacture, use or sell any patented invention that may in any way be related thereto.



CONFIDENTIAL

DEPARTMENT OF THE ARMY
OFFICE OF THE ADJUTANT GENERAL
WASHINGTON, D.C. 20310

IN REPLY REFER TO

AGAM-P (M) (17 Mar 69) FOR OT UT 684025

21 March 1969

AD 501008

SUBJECT: Rocket Study (U), Extract from Operational Report - Lessons Learned, Headquarters, II Field Force Vietnam Artillery, Period Ending 31 October 1968

SEE DISTRIBUTION
Espionage
Its translation
manner to an unauthorized person
National
and 794
ents in any
by law.

1. Extract from report, subject as above, is forwarded for review and evaluation in accordance with paragraph 5b, AR 525-15. Evaluations and corrective actions should be reported to ACSFOR OT UT, Operational Reports Branch, within 90 days of receipt of covering letter.
2. Information contained in this report is provided to insure appropriate benefits in the future from lessons learned during current operations and may be adapted for use in developing training material.

BY ORDER OF THE SECRETARY OF THE ARMY:

Kenneth G. Wickham

KENNETH G. WICKHAM
Major General, USA
The Adjutant General

1 Incl
as

- DISTRIBUTION:
- Commanding Generals
 - US Continental Army Command
 - US Army Combat Developments Command
 - Commandants
 - US Army War College
 - US Army Command and General Staff College
 - US Army Adjutant General School
 - US Army Air Defense School
 - US Army Armor School
 - US Army Aviation School
 - US Army Chemical School
 - US Army Civil Affairs School
 - US Army Engineer School
 - US Army Field Artillery School
 - US Army Infantry School
 - US Army Intelligence School

DECLASSIFIED BY 3...
DECLASSIFIED BY 12...
OCT 21 1980

APR 24 1969

Regraded unclassified when separated from classified inclosure.

CONFIDENTIAL

DISTRIBUTION (Cont'd)

US Army Military Police School
US Army Missile and Munitions School
US Army Ordnance School
US Army Security Agency School
US Army Special Warfare School
Armed Forces Staff College

Copies furnished:
Office, Chief of Staff, US Army
Deputy Chiefs of Staff
Chief of Research and Development
Assistant Chiefs of Staff
Chief of Engineers
OSD(SA) Assistant for Southeast Asia Forces
GINC, US Strike Command
Commanding Generals
 US Army Materiel Command
 US Army Weapons Command
 US Army Flight Training Center
Commander, US Army Forces Southern Command
National Aeronautics & Space Administration
Senior Army Representative, Marine Corps Development & Education Command
The Air University Library
Joint Action Control Office
Director, Weapons Systems Evaluation Group
Defense Documentation Center
Security Officer, Hudson Institute
Documents Control Officer, Bell Aero Systems Co.
Commanding Officers
 US Army Limited War Laboratory
 US Army Logistics, Doctrine Systems & Readiness Agency
Commandant of the Marine Corps (A 3H10)

CONFIDENTIAL



DEPARTMENT OF THE ARMY
HEADQUARTERS, II FIELD FORCE VIETNAM
APO SAN FRANCISCO 96266

AVFB-FAB

19 OCT 1968

SUBJECT: Rocket Study (U)

SEE DISTRIBUTION

1. The introduction of rockets into the Viet Cong/North Vietnamese Army (VC/NVA) arsenal in the Republic of Vietnam has presented us with a definite challenge. We are tasked with developing countermeasures which will stop the rocket threat or make it ineffective.
2. Much has been learned and written about the enemy rockets and of their employment by the VC/NVA. One vital aspect, however, still remains unsolved: how to detect and destroy these rockets prior to the time of attack.
3. This study provides background and the latest information available on VC/NVA rockets. It is anticipated that this information will assist our efforts to meet the enemy's challenge.

A handwritten signature in black ink that reads "Walter T. Kerwin, Jr." with a stylized flourish at the end.

WALTER T. KERWIN, JR.
Lieutenant General, USA
Commanding

DISTRIBUTION:
B

Regraded unclassified when separated
from classified inclosure.

FBR OT 4T
684025

CONFIDENTIAL

Inclosure 1

CONFIDENTIAL

TABLE OF CONTENTS

LIST OF FIGURES

INTRODUCTION

<u>CHAPTER</u>	<u>TITLE</u>	<u>PAGE</u>
I	CHARACTERISTICS OF 107MM ROCKET	2
II	CHARACTERISTICS OF 122MM ROCKET	4
III	CHARACTERISTICS OF 140MM ROCKET	6
IV	LAUNCHERS AND FIELD EXPEDIENTS	8
V	RECONNAISSANCE, SELECTION, AND OCCUPATION OF POSITION	17
VI	SURVEY AND CONTROL	22
VII	TIME FIRING DEVICE	23
VIII	EFFECTIVENESS OF STANDOFF MATERIAL	25
IX	OVERCALIBER 107MM ROCKET	26
X	OVERCALIBER 122MM ROCKET	30
XI	ROCKET CACHES AND CACHING TECHNIQUES	33
XII	TRANSPORTATION OF ROCKETS	35
XIII	ENEMY ARTILLERY	37
	BIBLIOGRAPHY	39

CONFIDENTIAL

	<u>LIST OF FIGURES</u>	<u>PAGE</u>
Figure 1	CHICOM 107mm Rocket	3
Figure 2	Soviet 122mm Rocket	5
Figure 3	Soviet 140mm Rocket	7
Figure 4a, b	107mm Rocket Launcher	9, 10
Figure 5	122mm Rocket Launcher	11
Figure 6	Crossed Stick Field Expedient Rocket Launcher	12
Figure 7	"H" Frame Field Expedient Rocket Launcher	14
Figure 8	Soviet Gunner's Quadrant	15
Figure 9	L-Shaped Trench	16
Figure 10	Typical Launch Position	18
Figure 11a, b	Soviet Aiming Circle	20, 21
Figure 12	Time Firing Device	24
Figure 13a, b, c	Overcaliber 107mm Rocket	27, 28, 29
Figure 14a, b	Overcaliber 122mm Rocket	31, 32
Figure 15	Organizational Chart	38

INTRODUCTION

The primary purpose of this study is to familiarize personnel with enemy rocketry, its method of employment, capabilities and characteristics. Specifically, this study is intended for personnel who normally do not have ready access to filed information concerning enemy rockets. Through knowledge of the enemy rocket threat, units can more effectively detect launch areas and prevent rocket firings within III Corps Tactical Zone. Much of the information contained in this publication has been extracted from the many reports and studies that have been made on this subject.

CONFIDENTIAL

CHAPTER I

CHARACTERISTICS OF THE 107MM ROCKET

The CHICOM 107mm rocket, H-12 (figure 1), is a spin-stabilized, barrage rocket possessing a high explosive fragmentation warhead. It is employed in the Republic of Vietnam (RVN) as an artillery barrage rocket against point and area targets. The 107mm is basically an improved version of the CHICOM 102mm rocket.

The rocket consists of five major components:

1. A point detonating fuze
2. A high explosive fragmentation warhead
3. A warhead-to-motor adapter
4. A rocket motor
5. A Venturi motor plate with six canted nozzles which produce a clockwise spin.

The 107mm rocket employs the CHICOM type 1 fuze, which is essentially a copy of the V-25 fuze. This fuze has superquick and delay settings and is armed by centrifugal force. The rocket is launched electrically from a manufactured launcher or any one of several improvised launchers, i.e., mounds of dirt and cross sticks (see Chapter IV). The rocket can be launched in approximately three minutes from a remote position, using 40 meters of electrical wire or a delayed firing device capable of up to 12 hours delay (figure 12).

CONFIDENTIAL

Weight w/fuze	41.75 pounds
Length w/adapter	33 inches
Diameter	4.22 inches
Stabilization	Spin
Color: Old series	Battleship Gray
	New series
Range (maximum)	8300 Meters



FIGURE 1
 CHICOM 107MM ROCKET
 3

CONFIDENTIAL

CHAPTER II

CHARACTERISTICS OF 122MM ROCKET

The Soviet 122mm rocket, DKZ (figure 2), is a fin-stabilized barrage rocket possessing a high explosive fragmentation warhead. It is an indirect fire weapon employed effectively against point and area targets.

The 122mm rocket consists of four major components:

1. A point detonating fuze
2. A high explosive fragmentation warhead
3. A rocket motor
4. A folding fin-stabilizer unit

The fuze, Soviet DKZ-B, is setback armed with instantaneous, short delay, and long delay settings. The warhead is constructed of forged machine steel with two pre-engraved fragmentation sleeves press-fitted into the warhead housing.

The 122mm rocket can be fired electrically from a tube-type launcher or any of several field expedient launchers to include crossed sticks and mounds of dirt. Launching can be accomplished in three minutes from a remote position, utilizing approximately 40 meters of electrical wire or a timing device which permits from one minute to 12 hours delay (figure 12).

CONFIDENTIAL

Weight w/ fuze
Length w/ fuze
Diameter
Stabilization
Color: Warhead
Motor
Range (maximum)

101.85
75.4 inches
4.8 inches
Fin & Spin
Dark Gray
Aluminum
11,000 Meters



FIGURE 2
SOVIET 122MM ROCKET

CONFIDENTIAL

CHAPTER III

CHARACTERISTICS OF 140MM ROCKET

The Soviet 140mm spin-stabilized, barrage-type rocket (figure 3) was designed for use with a 16-round vehicular-mounted launcher. For employment in the Republic of Vietnam, the original launcher has been dismantled and the tubes mounted on wooden planks singly or in pairs. The 140mm rocket has three major components:

1. A point detonating fuze
2. A high explosive fragmentation warhead
3. A rocket motor

The fuze is armed by centrifugal force and has instantaneous and delay settings. The rocket is fired electrically from its tube launcher or from any one of several field expedient launchers. It is a lightweight weapon (122 pounds with launcher) that can be carried over rugged terrain with relative ease. Yet it provides the VC/NVA an increased destruction potential approaching that of a Soviet 152mm gun-howitzer.

The 140mm rocket has not been used in III Corps Tactical Zone to date. A possible explanation may be the difficulty in transporting the weapon. Because of its weight, the 140mm rocket does not lend itself to infiltration into the southern portions of RVN. It is true that the 122mm rocket which is often used throughout the III Corps Tactical Zone, is heavier than the 140mm rocket; however, the 122mm is a more effective weapon with greater range and requires the same number of men to transport it as does the 140mm rocket. It may be that the VC/NVA have determined that the effect of carrying ordnance great distances can best be offset by carrying the most effective ordnance they can obtain.

CONFIDENTIAL

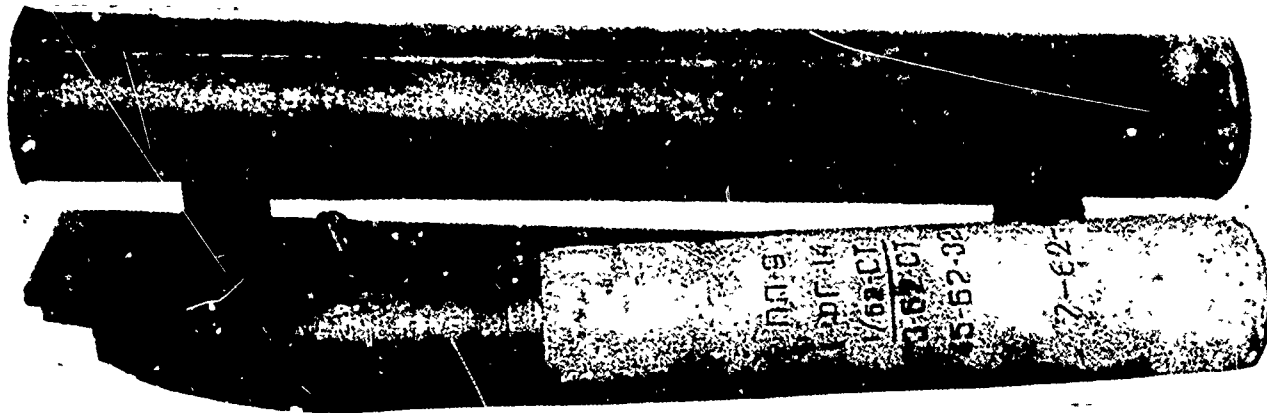

Launcher Tube and Wooden Plank	
Length	45 inches
Weight, single tube	22 pounds
Weight, double tube	45 pounds
Rocket, Spin-Stabilized	
Length	42.35 inches
Weight	88 pounds
Range	10,000 Meters
Fuze, PD, Model V-25	
Type of action	Instantaneous, short delay, long delay
Weight	1.4 pounds
Warhead	
Weight w/o fuze	41 pounds
Filler weight	9.25 pounds
Filler type	TNT
Length	15.5 inches

FIGURE 3
SOVIET 140MM ROCKET AND LAUNCHER

CONFIDENTIAL

CHAPTER IV

LAUNCHERS AND FIELD EXPEDIENTS

The 107mm rocket launcher (figure 4a) consists of two tubes in a metal cradle assembly. The rockets are fired electrically through a spring loaded locking mechanism at the rear of each tube. The configuration of electrical contacts indicates that the rockets can be fired simultaneously. The launcher is of CHICOM manufacture. The dual-tubed launchers may be connected to a larger, four-tube assembly to form a 12-tube configuration (figure 4b). This is done by means of T-shaped locking lugs which slide into channels on the four-tubed assembly. The launcher is mounted on a platform supported by four legs. It has a traversing and elevation capability of 35 degrees and 45 degrees respectively using the gear box mechanism which attaches the tube assembly to the mount.

A tripod-mounted tube launcher is the most accurate delivery means of the 122mm rocket (figure 5). The tube section of this unit is removed from a Soviet multi-tubed vehicular launcher. The tripod is fabricated in-country. The system is equipped with both optical and mechanical open sights. The weight of the 122mm launcher (110 pounds) and its bulky size increases the time required for march order and permits counter-rocket fire to effectively engage the launch site before the enemy can evacuate the position. To preclude this, the enemy has developed three field expedient launchers. The most prevalent field expedient method of launching the rocket is to support the front of the rocket in the fork of two crossed sticks while the rear rests on the ground (figure 6). The sticks are tied together with

CONFIDENTIAL

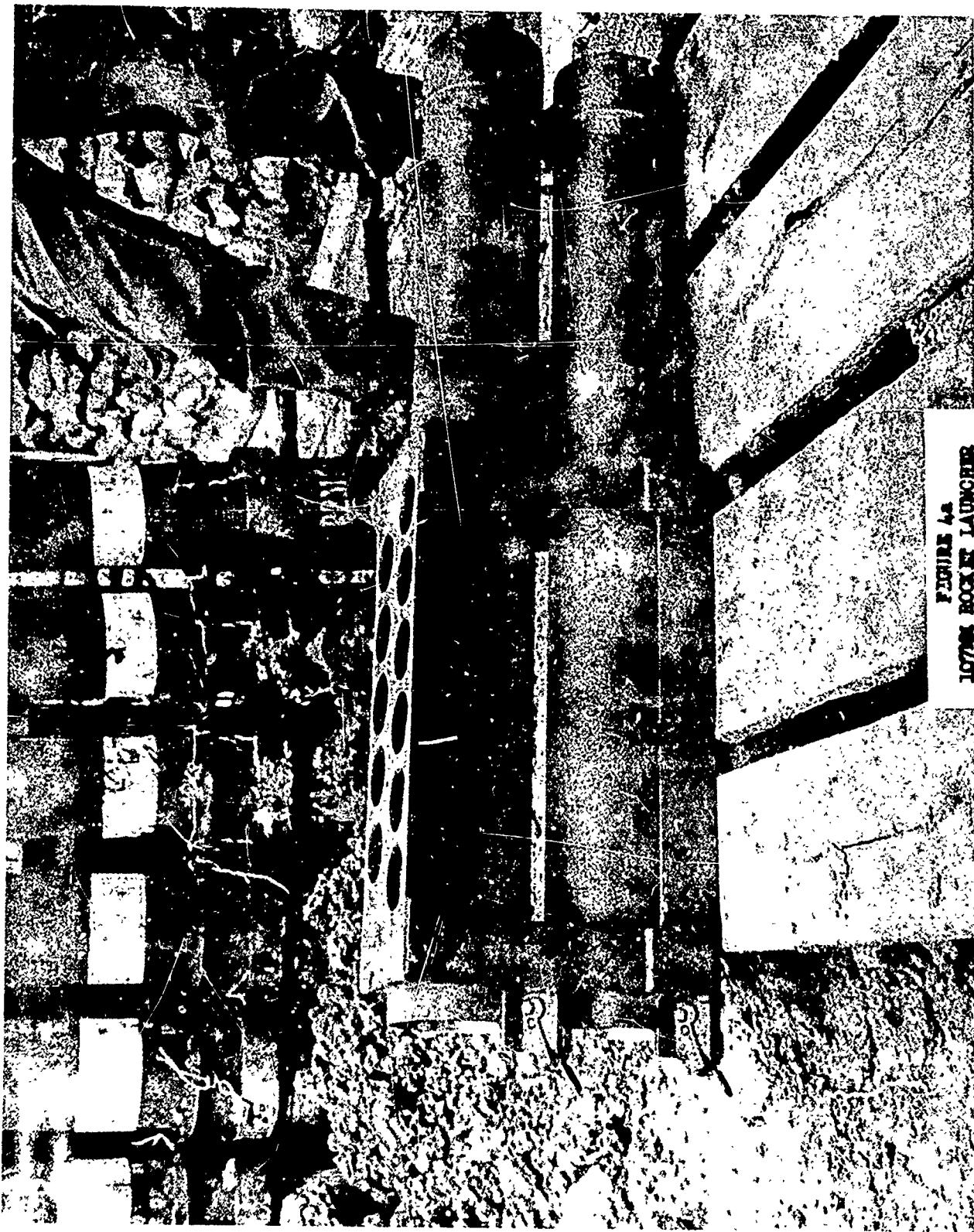

FIGURE 4a
107MM ROCKET LAUNCHER

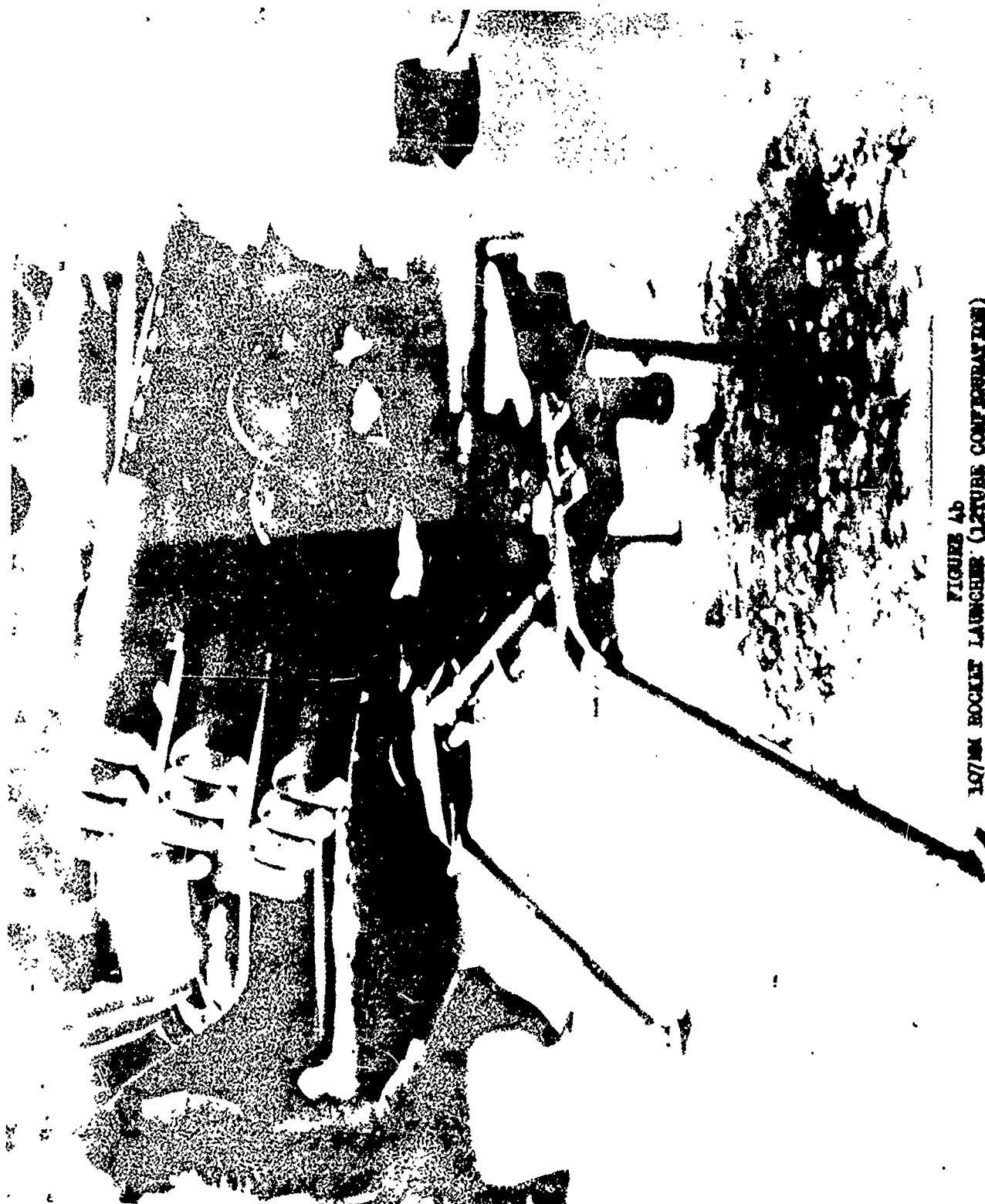

FIGURE 4b
107MM ROCKET LAUNCHER (LECTURE CONFIGURATION)

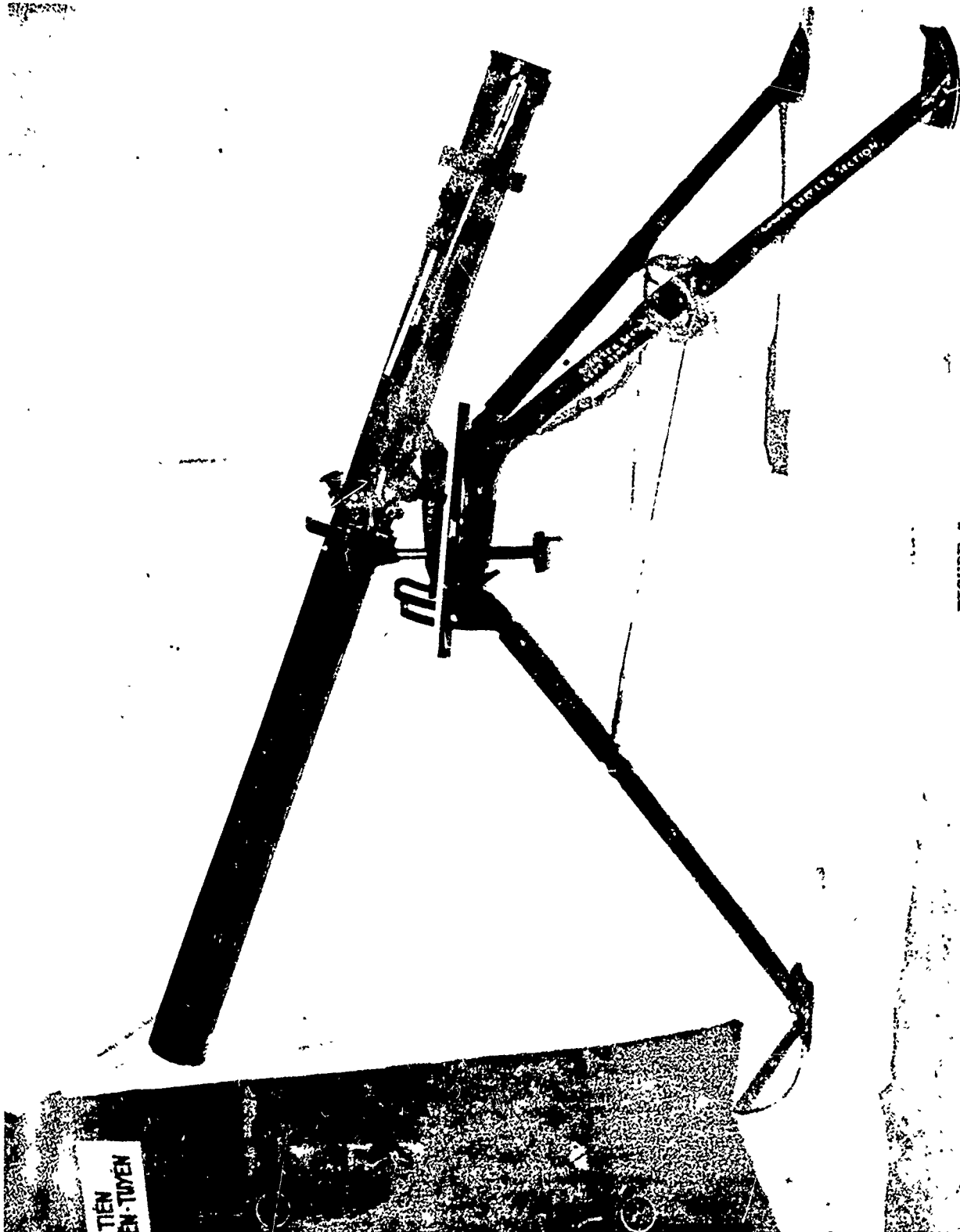

FIGURE 5
SOVIET 122MM ROCKET LAUNCHER



FIGURE 6
CROSSED STICK FIELD EXPEDIENT
ROCKET LAUNCHER

CONFIDENTIAL

vines or wires and the weight of the rocket keeps the "launcher" upright until the rocket is fired.

Another field expedient method is the use of three sticks in an "H" configuration (figure 7). The two uprights are forced into the ground and the crosspiece lashed in place. In this case, the front of the rocket is placed on the crosspiece and the base rests on the ground. The third method consists of simply leaning the rocket against a mound of dirt at the desired elevation and pointing it in the proper direction. In all cases, a gunner's quadrant (figure 8) is used to obtain the proper elevation. The rocket is laid for direction either with a compass or by visually aligning the rocket with a known aiming point or with the target. Time for laying and firing in this manner is approximately three minutes.

The enemy sacrifices both range and deflection accuracy using these field expedients; however, he requires virtually no march order preparation and can more easily avoid casualties from counter-rocket fire. Often found in conjunction with these launchers at launch sites are "L" shaped and "U" shaped trenches (figure 9). Rockets are stored in one end of the trench while the gunner uses the other end.

CONFIDENTIAL

CONFIDENTIAL



CONFIDENTIAL

FIGURE 7
"H" FRAME FIELD EXPEDIENT
ROCKET LAUNCHER

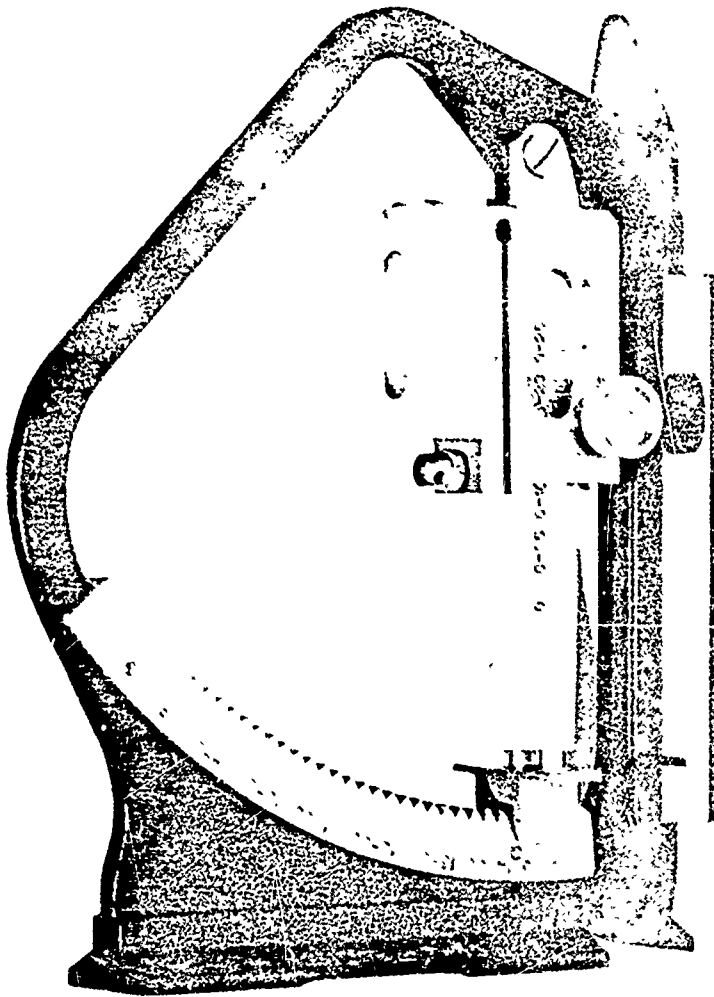

GUNNER'S QUADRANT (UPRIGHT) W/2" RULER IN FOREGROUND CAPTURED BY 1st AMTRAC BN
VIC of KY LAM (YD250677) 29 AUG 67

FIGURE 8
SOVIET GUNNER'S QUADRANT

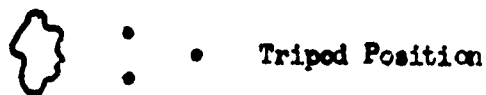
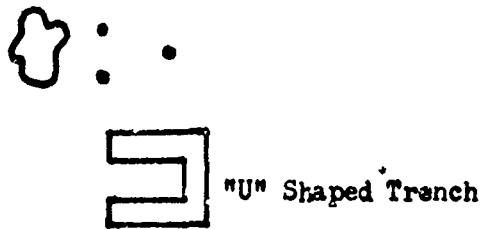
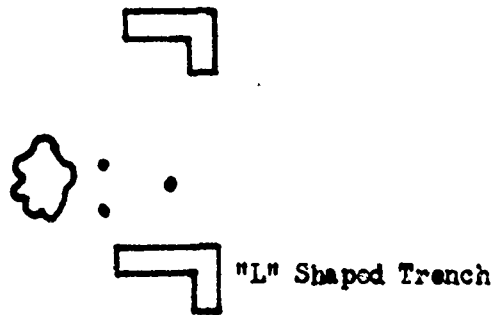

FIGURE 9
 TYPICAL 122MM ROCKET LAUNCH SITE UTILIZING
 L-SHAPED TRENCHES FOR A BATTERY-SIZE UNIT

CONFIDENTIAL

CHAPTER V

RECONNAISSANCE, SELECTION AND OCCUPATION OF POSITION

The enemy has fired his rockets from almost every type of terrain, however, several characteristics are of primary concern to the reconnaissance party when selecting a launch site. The enemy has shown preference for areas easily accessible by trails, roads or waterways. This facilitates fast occupation and, after firing, rapid withdrawal from the position.

The VC normally fire from areas which offer low hills or dense vegetation between the firing position and the target. This serves to conceal the rocket flash from observers. Vegetation around an area also will muffle the firing noise from friendly elements. Recently the VC have chosen to fire from positions close to friendly troop concentrations or populated areas to avoid the counter-rocket fire which follows a rocket attack.

A rocket launch position utilizing tripod-mounted launchers and "L" shaped control trenches (figure 10) can be established and the rockets fired in a maximum of two hours; however, this preparation time can be reduced substantially by the use of field expedient launchers and remote firing positions. Remote firing positions obviate the need for trenches, thus reducing preparation time. By using expendable field expedient launchers, the VC have no equipment to retrieve and can leave the area immediately after firing. The enemy also has used a time firing device, thus making it unnecessary for him to be present in the area at the time of firing.

Field expedient rocket launchers are being used more frequently by the VC than tube-type launchers. By using these launchers, the enemy decreases

CONFIDENTIAL



FIGURE 10
L-SHAPED TRENCH

CONFIDENTIAL

his accuracy in both range and deflection; however, this system has proven quite adequate to engage area-type targets.

Reconnaissance and survey personnel may mingle with groups of persons such as woodcutters or rubber plantation workers. Groups such as these should be observed closely for suspicious activities. Groups observed carrying objects resembling survey equipment, i.e., tapes, aiming stakes or an aiming circle similar to the US M1 aiming circle also should be scrutinized. Firing sites may be identified by indicators such as stakes denoting future launcher positions, sticks laid on the ground in an arrow shape showing direction of fire, various configurations of aiming stakes to include marked living trees and firing trenches or pits. Launch positions which the VC have used should be checked often. If any indications of imminent launch are present, the surrounding area should be carefully searched for equipment or cached rockets.

Large or uncommon numbers of civilians moving into and out of an area, evidences of digging, people carrying cylindrical objects or even cattle or water buffalo in unusual places should be investigated.

If unit personnel making sweeps through known or suspected rocket areas have knowledge of the indicators suggesting rocket activity and if timely reports of such indicators are rendered, much can be done to eliminate the rocket threat in the III Corps Tactical Zone.

As in US artillery, the VC/NVA conduct reconnaissance, selection and occupation of position before firing their rockets. The initial reconnaissance may take place three to five days prior to the day selected for launch. Survey control, if used, also may be brought in at this time, using Soviet aiming circles (figures 11a, b) similar to the US M1 aiming circle. French survey control points are used when available.

CONFIDENTIAL

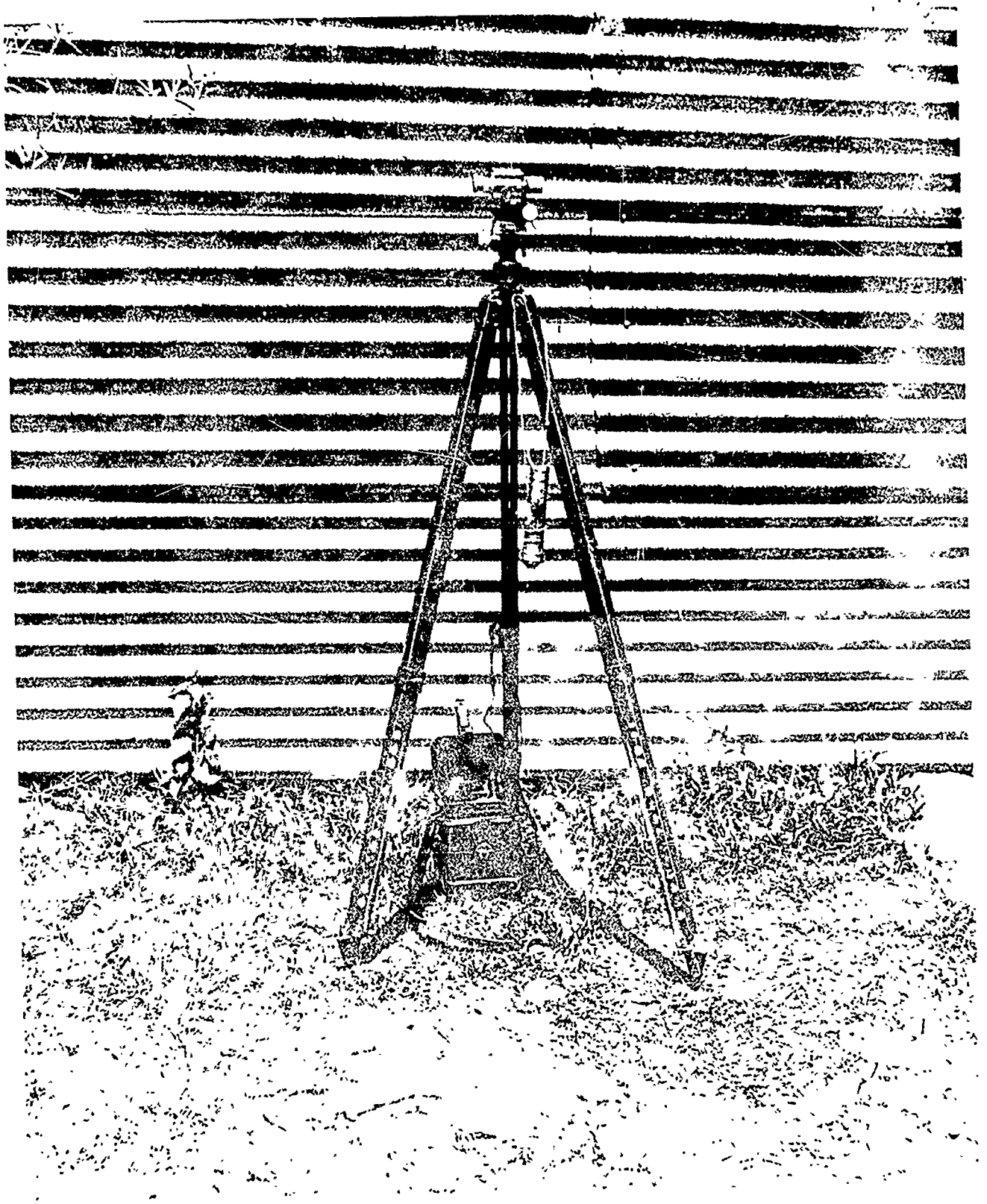

FIGURE 11a
SOVIET AIMING CIRCLE

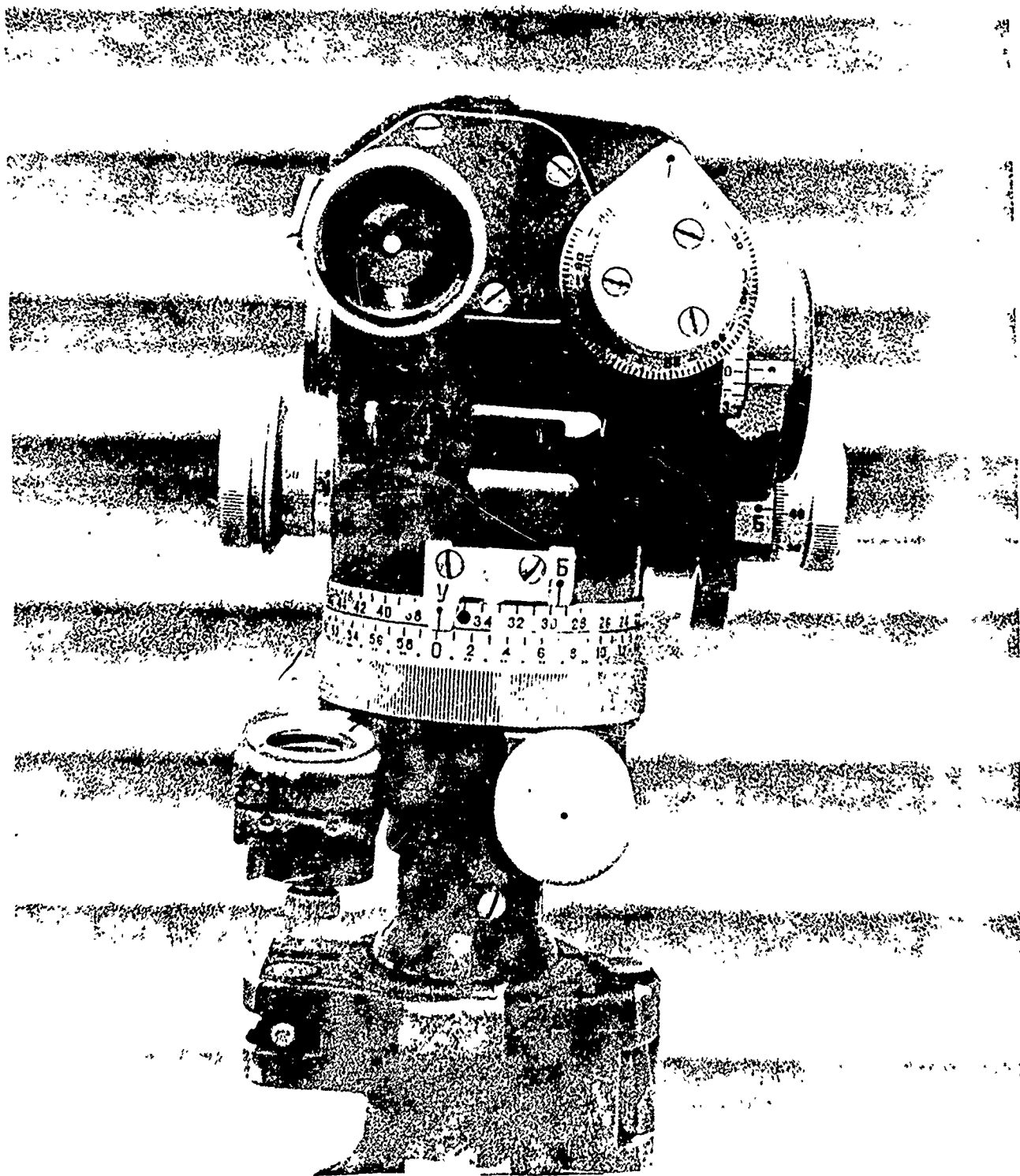

FIGURE 11b
SOVIET AIMING CIRCLE

CONFIDENTIAL

CHAPTER VI

SURVEY AND CONTROL

The VC/NVA have been able to fire rockets accurately enough to damage FwMAF Air Bases and equipment and to harass personnel in base camps. Their accuracy is obtained using limited survey control, map-spot coordinates, or a map from which the direction of fire and range are determined. Survey control is brought into an area using Soviet-type aiming circles. French originated survey control points are used where available.

It has become increasingly evident that enemy rocket units favor some firing locations over others and use these frequently, sometimes as often as two nights in succession. This could mean that the enemy has established survey control to these points or merely that he has experienced success in firing from them initially and is trying to duplicate his success with minimum effort. Another reason is that the launch position may be located near a supply route or ammunition cache. Areas near rocket launch sites should be thoroughly investigated.

CONFIDENTIAL

CONFIDENTIAL

CHAPTER VII

TIME FIRING DEVICE

On 27 August 1968, Company C, 1st Battalion, 26th Infantry, 1st Infantry Division, located three 122mm rockets in a firing position. These three rockets were connected to a time firing device (figure 12).

This device consists of an ordinary wristwatch connected by wires to a set of dry cell batteries. One wire is connected to the case of the watch while the second is attached to a screw secured to the face of the watch at the desired firing time. If less than one hour is desired, the hour hand is removed. The timing device will set off the rocket when the minute hand contacts the screw thereby completing the electrical circuit. If more than one hour is desired, the minute hand is removed. The timing device will set off the rocket when the hour hand makes contact with the screw thereby completing the electrical circuit. The maximum delay utilizing such a system is 12 hours, using the hour hand.

A time firing device greatly enhances the enemy's capability of escaping the intense counterbattery fire which usually follows a rocket attack.

CONFIDENTIAL



FIGURE 12
TIME FIRING DEVICE

CONFIDENTIAL

CHAPTER VIII

STANDOFF MATERIAL

Standoff material is relatively ineffective against the 107mm, 122mm and 140mm rockets. A 122mm rocket can be compared to the US 155 Howitzer round in velocity and in effect. Pierced steel planking (PSP) and chain link fence will detonate a rocket fired with fuse quick; however, these materials will have little effect on a rocket fired with delay or long delay fuse settings. In one instance, a 122mm rocket with a fuse cut for long delay passed through a UH1-B, the PSP beneath it and several feet of earth before exploding.

CONFIDENTIAL

CONFIDENTIAL

CHAPTER IX

OVERCALIBER 107MM ROCKET

Elements of the 5th Special Forces Group discovered a complete 107mm overcaliber rocket (figure 13a, 13b, 13c) in their area. This is the first known recovery of an overcaliber 107mm rocket in RVN.

The overcaliber rocket is composed of:

1. A complete standard production CHICOM 107mm rocket without fuze
2. A 200mm homemade warhead containing 27.75 pounds of plastic explosive
3. 25.5 inches of detonator cord
4. A PG-2 warhead in a shaped charge configuration
5. A 200mm aerodynamic drogue.

The warhead and drogue are secured to the rocket with homemade clamps.

The rocket is armed with a point-detonating mortar fuze or the base-detonating DK-2 fuze from the PG-2 antitank grenade. It is not known how this rocket is to be launched.

CONFIDENTIAL

Total Length	54.25 inches
Total Weight w/o fuze	82.5 pounds
Major Diameter	200mm
Diameter of rocket	200mm
Diameter of 107mm Rocket	107mm
Diameter of Drogue	200mm
Range	3000 meters
Stabilizer Assembly	Drogue
Type Fuze	PD Mortar Fuze or DK-2

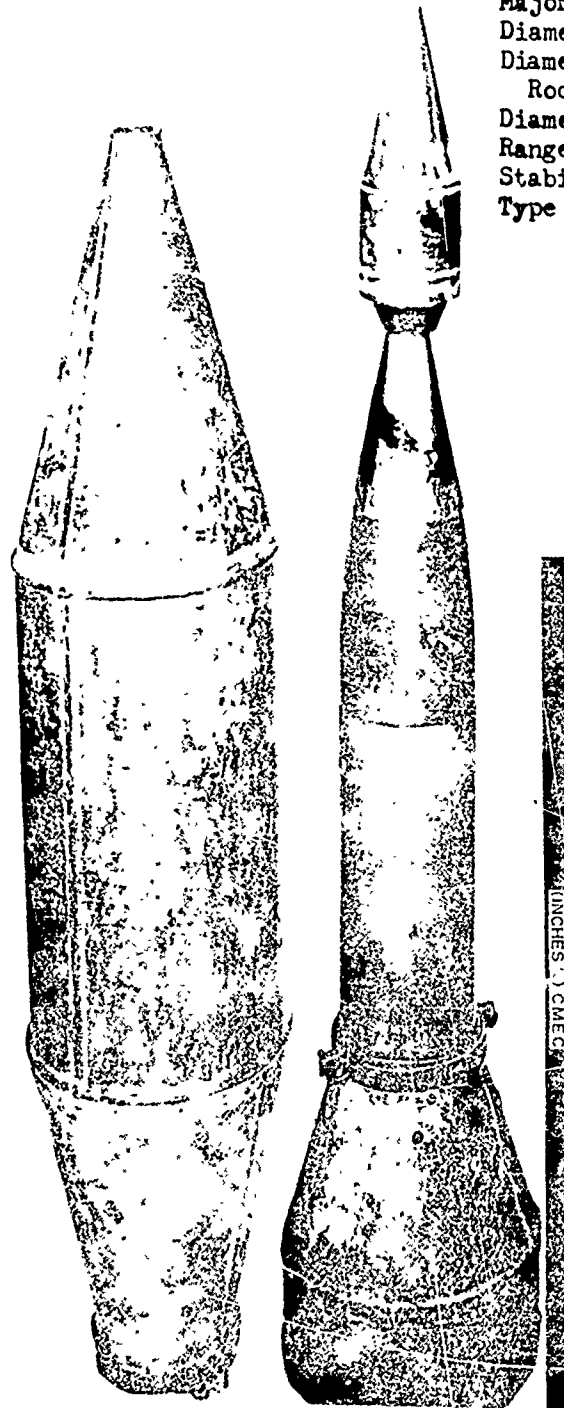

FIGURE 13a
OVERCALIBER 107MM ROCKET



FIGURE 13b
OVERCALIBER 107MM ROCKET

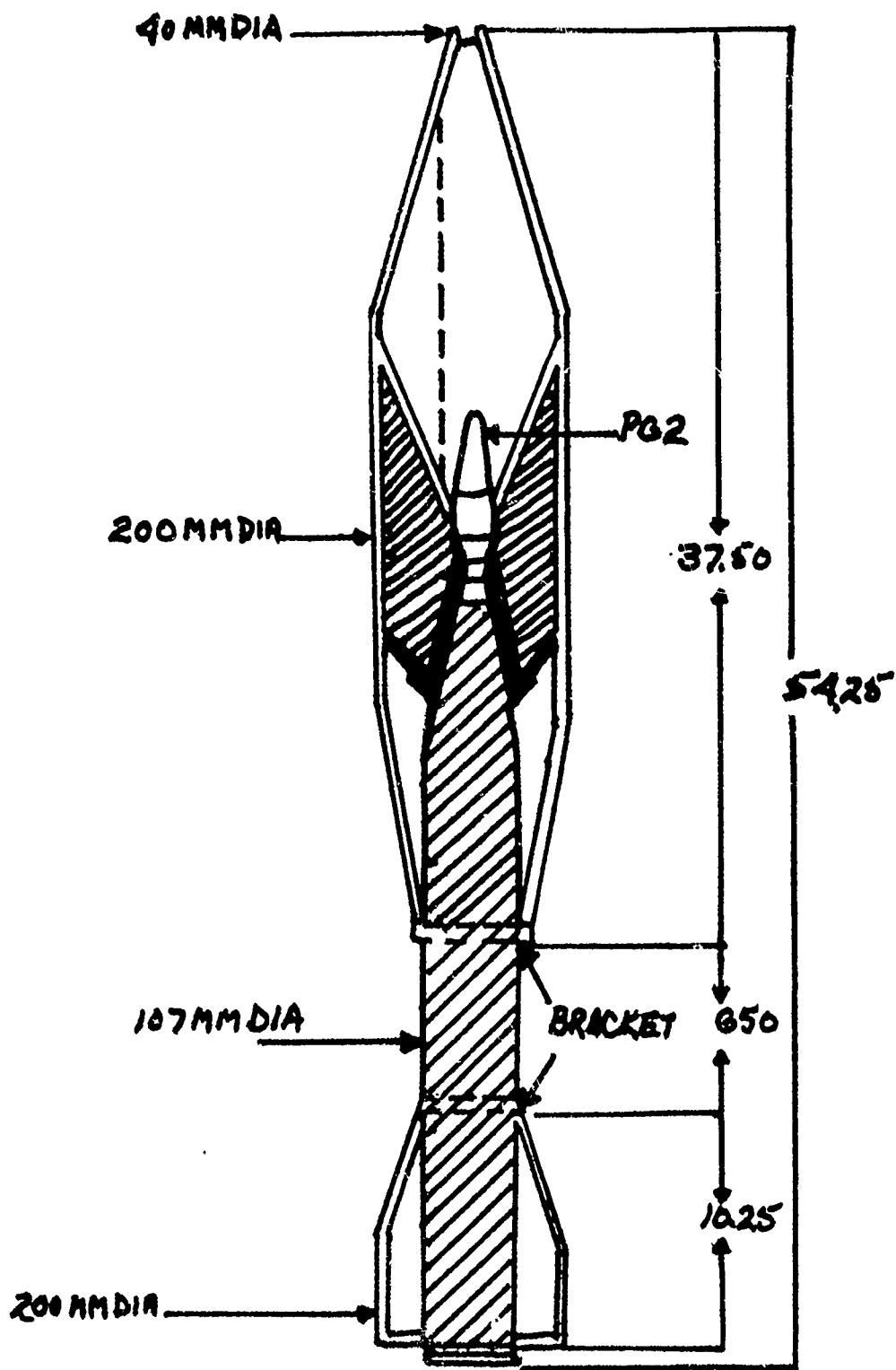

FIGURE 13c
 OVERCALIBER 107MM ROCKET

CONFIDENTIAL

CHAPTER X

OVERCALIBER 122MM ROCKET

A complete 122mm overcaliber rocket (figure 14a, 14b) was recovered by the Navy EOD team at the Long Tam River. This is the second recovery of an overcaliber 122mm rocket. The first recovery, an incomplete round, occurred at Katum Special Forces Camp. The two rockets are similar in design but not alike in detail and caliber.

The complete rocket consists of three major components:

1. A Soviet 122mm rocket motor, complete with folding fin assembly
2. A 400mm shaped charge warhead, weighing 216 pounds and containing 170 pounds of TNT
3. A 400mm shroud-type tail fin mounted over the folding fins.

The rocket is armed with a DKZ-B 122mm rocket fuse and launched from a ladder-type launcher. The launcher consisted of two parallel rails, 80 inches long, reinforced by cross members. The rails are 10 inches apart.

CONFIDENTIAL

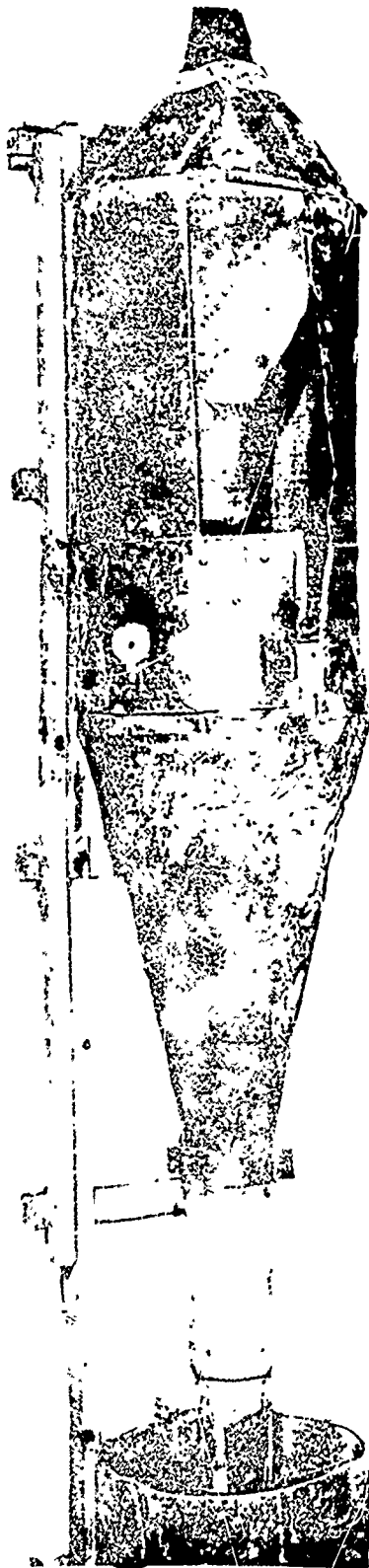

Major Diameter	400mm
Diameter of warhead	400mm
Diameter of rocket	
Motor	122mm
Diameter of stabilizer assembly	400mm
Length	83 inches
Weight	281 pounds
Range (est.)	1000 Meters
Stabilizer Assembly	Shroud type
PDFuze	DKZ-B

FIGURE 14a
OVERCALIBER 122MM ROCKET

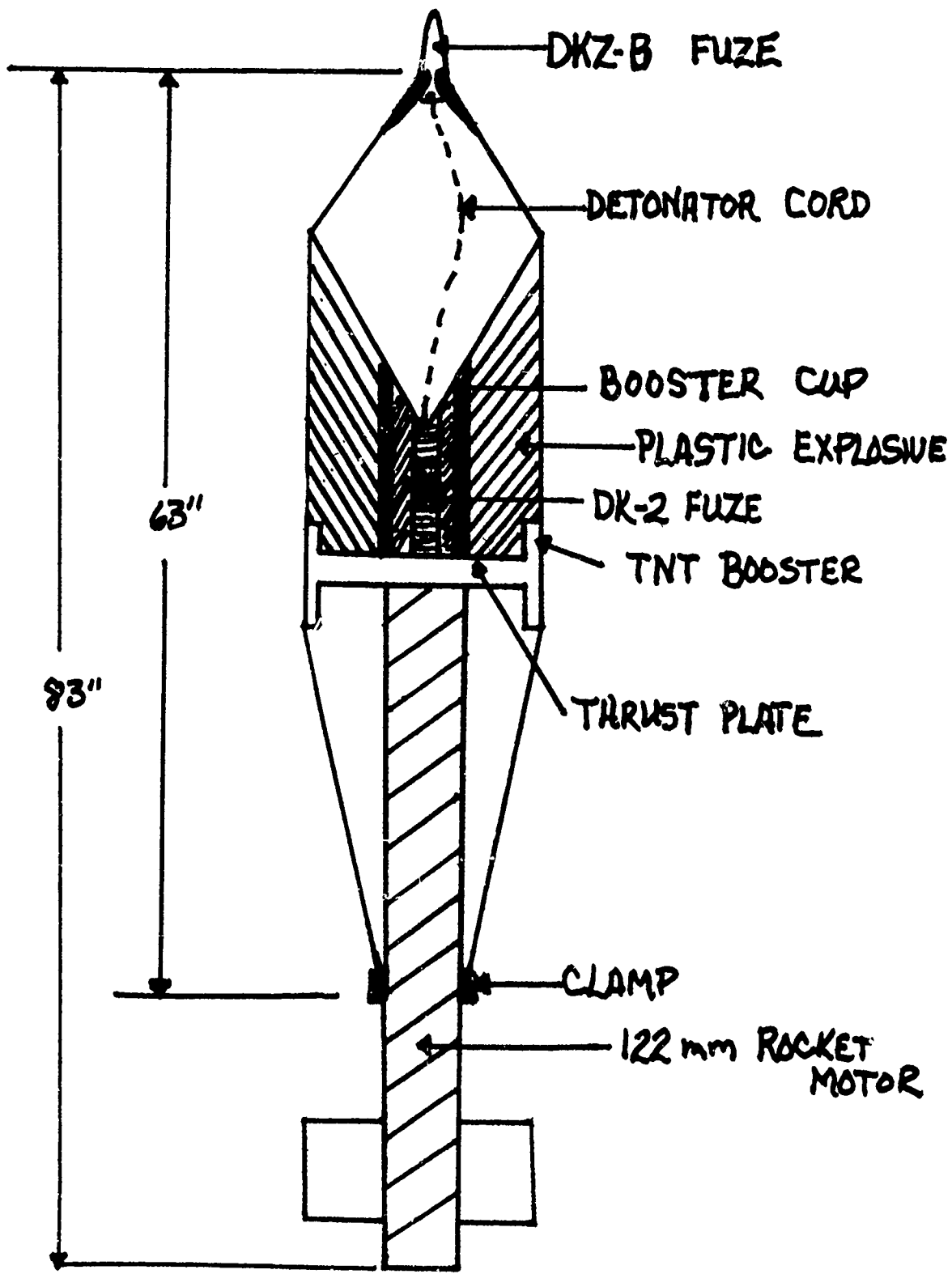

FIGURE 14b
OVERCALIBER 122MM ROCKET

CONFIDENTIAL

CHAPTER XI

ROCKET CACHES AND CACHING TECHNIQUES

Recent experience in the southern portions of the 1st Infantry Division TAOI indicates that enemy rocket units and rear service transportation elements have been locating caches of rocket weapons near waterways and tributaries. Those that have been found have been near the banks of these waterways, usually in areas where there is a heavy growth of nipa palm or other natural cover. Apparently, the rockets are moved into forward areas by water wherever possible and cached near the point where they are unloaded from the sampans.

The 122mm rocket components are carefully packed to be as watertight as possible. The motor is packed in a sealed cylindrical container, the warhead usually is given a coat of Soviet artillery grease (about 40% wax) and the base and fuze well sealed with threaded bakelite cap.

Given this packing, the components could be submerged in waterways or marshy areas for limited periods of time to hide them from friendly sweep operations. The 25th Infantry Division has reported discovering a variation of the submerged caching technique in their TAOI. The 25th Division elements recently discovered a large rocket cache in 55-gallon drums, the drums having been submerged in a marshy area.

There is some evidence to suggest that, contrary to previous practices, the enemy is locating his rocket caches within 300 to 400 meters of his firing sites. This has not occurred in a sufficient number of instances as yet to be a recognized tactic; however, in the Tan Uyen area and in the southern portion of the 1st Infantry Division TAOI, cache sites can

CONFIDENTIAL

CONFIDENTIAL

be expected near known or suspected enemy firing positions.

The enemy apparently will use the same cache site several times, even if it is discovered and destroyed by friendly forces. The fact that an area has been used for cache sites before and that the caches were discovered is not a reason to suppose that subsequent sweeps through the area will not find additional caches in the same immediate area.

CONFIDENTIAL

CONFIDENTIAL

CHAPTER XII

TRANSPORTATION OF ROCKETS

Under normal conditions, a single 122mm rocket round is carried in its disassembled state by two people. One of these carriers carries the warhead in a specially designed cylindrical pack made of heavy OD or grey canvas. This same man also may carry the fuze which is carried in a small triangular canvas pocket, clipped with a snap hook to one of the straps of the warhead back pack. The motor also has a specially designed cylindrical carrying case of the same type of canvas material. This case has strap handles at either end so that it may be carried by two people. The man with the warhead will carry one end, while his partner carries the other. Occasionally, three people will be used to transport a rocket, particularly if the rocket is to be carried a long distance. In this case, one man will have the warhead in its back pack, while the other two carry the rocket motor.

If the conventional tripod-mounted tube launcher (DKB) is to be used in the attack, an additional 4 to 6 men will be used to carry its components. Normally, two men will carry the folded tripod slung on a carrying pole between them; two more men will carry the launcher tube, and two more will carry the sight, firing cable, night lighting equipment, hell box (blasting machine), and pioneer tools. In a well-equipped section, the gunner will have an elongated back pack with two compartments in which most of the accessories for the launcher are carried. As the normal basic load for a launcher section is three rockets, a complete launcher crew with its basic load will consist of from 12 to 15 men.

CONFIDENTIAL

CONFIDENTIAL

Recently, there has been a noticeable increase in the number of field expedient launchers used by enemy rocket artillery units. Captured documents have indicated that the enemy is increasingly afraid of US/FWMAF counterbattery fire, and is reluctant to carry and emplace the relatively bulky, easily-recognized conventional launcher. They appear to be willing to sacrifice the greater accuracy of the launcher for the ability to emplace rockets quickly and evacuate the launch position rapidly. One of the commonest forms of field expedient launcher is a pair of crossed sticks, lashed together about 8" from one end with a length of WD-1 wire about 30" long to prevent them from spreading and collapsing when the weight of the rocket is placed on the launcher. When a launcher section moves to an attack position from which they intend to use a field expedient launcher, there will be far fewer personnel in the group; and -- depending on where the rockets have been cached and what type of field expedient launcher is to be used -- they will carry little or no equipment, other than their individual weapons and firing cables.

CONFIDENTIAL

CONFIDENTIAL

CHAPTER XIII

ENEMY ARTILLERY

The major enemy artillery command in III Corps Tactical Zone (CTZ) is the 69th Artillery Command. It is directly subordinate to COSVN and has three regiments with a rocket launching capability. They are the 84A, 96th and 208th Artillery Regiments. These three units have the capability of launching both the 107mm rocket and the 122mm rocket. Elements of the battalions of these regiments have been attached to various VC/NVA units to provide them direct artillery support.

The 84A Artillery Regiment is currently operating with units in Ba Bien Province and probably is responsible for attacks in the Long Binh/Bien Hoa area, as it was during the TET and May offensives.

The 96th Artillery Regiment is believed to be operating with units in Tay Ninh Province and War Zone C. The rocket attacks on bases in this area probably can be attributed to elements of this unit.

The 208th Artillery Regiment currently is operating in Sub-Regions 1, 2, 3, and 5 as it did during the first two general offensives. This unit probably is responsible for attacks on the Saigon area.

It is probable that only one or two men in a battery-size unit have been trained in laying and firing rockets. There have been reports by Hoi Chanh's and PW's indicating that units were unable to fire on a selected date because their technician had been detained.

CONFIDENTIAL

CONFIDENTIAL

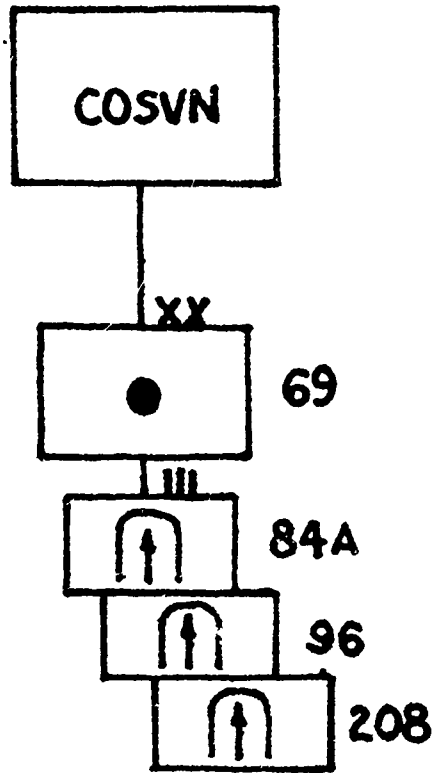

FIGURE 15
ORGANIZATIONAL CHART

BIBLIOGRAPHY

STUDIES

Combined Intelligence Center Vietnam. VC/NVA Employment of 140mm
Rockets in the attack on Da Mang Airbase, 27 February 1967,
ST 67-046. April 1967.

Combined Intelligence Center Vietnam. NVA Rocket Artillery Units,
ST 67-080. September 1967.

Headquarters 11th Armored Cavalry Regiment. Rocket Study, undated.

UNCLASSIFIED

Security Classification

DOCUMENT CONTROL DATA - R & D

(Security classification of title, body of abstract and indexing annotation must be entered when the overall report is classified)

1. ORIGINATING ACTIVITY (Corporate author)		2a. REPORT SECURITY CLASSIFICATION	
HQ, OACSFOR, DA, Washington, D.C. 20310		CONFIDENTIAL	
		2b. GROUP	
		4	
3. REPORT TITLE			
Rocket Study (U), Extract from Operational Report - Lessons Learned, Hq, Field Force Vietnam Artillery, Period Ending 31 October 1968			
4. DESCRIPTIVE NOTES (Type of report and inclusive dates)			
Experiences of unit engaged in counterinsurgency operations.			
5. AUTHOR(S) (First name, middle initial, last name)			
CG, Hq, II Field Force Vietnam Artillery			
3. REPORT DATE		7a. TOTAL NO. OF PAGES	7b. NO. OF REFS
19 Oct 1968		45	
8a. CONTRACT OR GRANT NO.		9a. ORIGINATOR'S REPORT NUMBER(S)	
b. PROJECT NO.		684025	
c. N/A		9b. OTHER REPORT NO(S) (Any other numbers that may be assigned this report)	
d.			
10. DISTRIBUTION STATEMENT			
11. SUPPLEMENTARY NOTES		12. SPONSORING MILITARY ACTIVITY	
N/A		OACSFOR, DA, Washington, D.C. 20310	
13. ABSTRACT			