

UNCLASSIFIED

AD NUMBER

AD506707

CLASSIFICATION CHANGES

TO: UNCLASSIFIED

FROM: CONFIDENTIAL

LIMITATION CHANGES

TO:  
Approved for public release; distribution is unlimited.

FROM:  
Distribution authorized to U.S. Gov't. agencies and their contractors;  
Administrative/Operational Use; 19 NOV 1969.  
Other requests shall be referred to Assistant Chief of Staff Force Development (Army), Washington, DC 20310.

AUTHORITY

AGO D/A ltr 31 Oct 1980; AGO D/A ltr 31 Oct 1980

THIS PAGE IS UNCLASSIFIED

AD- 506707

SECURITY REMARKING REQUIREMENTS

DOD 5200.1-R, DEC 78

REVIEW ON 19 NOV 89

THIS REPORT HAS BEEN DELIMITED  
AND CLEARED FOR PUBLIC RELEASE  
UNDER DOD DIRECTIVE 5200.20 AND  
NO RESTRICTIONS ARE IMPOSED UPON  
ITS USE AND DISCLOSURE.

DISTRIBUTION STATEMENT A

APPROVED FOR PUBLIC RELEASE;  
DISTRIBUTION UNLIMITED.

# DISCLAIMER NOTICE

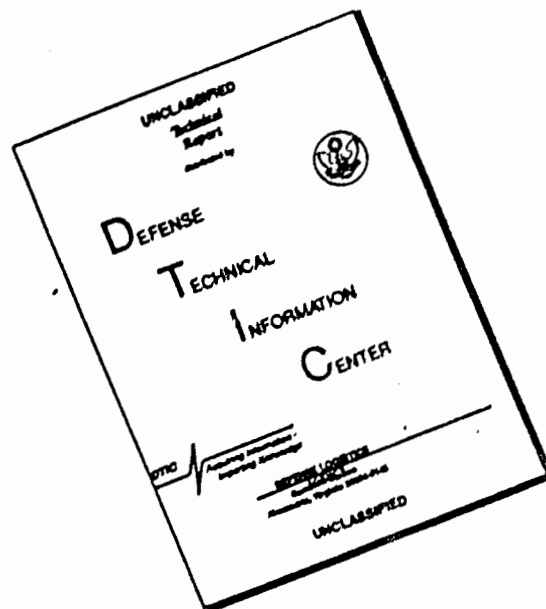

THIS DOCUMENT IS BEST QUALITY AVAILABLE. THE COPY FURNISHED TO DTIC CONTAINED A SIGNIFICANT NUMBER OF PAGES WHICH DO NOT REPRODUCE LEGIBLY.

# **SECURITY**

---

# **MARKING**

**The classified or limited status of this report applies to each page, unless otherwise marked.**

**Separate page printouts MUST be marked accordingly.**

---

THIS DOCUMENT CONTAINS INFORMATION AFFECTING THE NATIONAL DEFENSE OF THE UNITED STATES WITHIN THE MEANING OF THE ESPIONAGE LAWS, TITLE 18, U.S.C., SECTIONS 793 AND 794. THE TRANSMISSION OR THE REVELATION OF ITS CONTENTS IN ANY MANNER TO AN UNAUTHORIZED PERSON IS PROHIBITED BY LAW.

NOTICE: When government or other drawings, specifications or other data are used for any purpose other than in connection with a definitely related government procurement operation, the U.S. Government thereby incurs no responsibility, nor any obligation whatsoever; and the fact that the Government may have formulated, furnished, or in any way supplied the said drawings, specifications, or other data is not to be regarded by implication or otherwise as in any manner licensing the holder or any other person or corporation, or conveying any rights or permission to manufacture, use or sell any patented invention that may in any way be related thereto.



**CONFIDENTIAL**

**DEPARTMENT OF THE ARMY  
OFFICE OF THE ADJUTANT GENERAL  
WASHINGTON, D.C. 20310**

IN REPLY REFER TO

AGDA (M) (29 Dec 69)

FOR OT UT 69B052

6 January 1970

**SUBJECT:** Senior Officer Debriefing Report: BG Allan G. Pixton, CG, XXIV  
Corps Artillery, Period 2 September 1968 through 20 November  
1969 (U)

SEE DISTRIBUTION

\*This document contains information affecting the National  
Defense of the United States within the meaning of the  
Espionage Laws, Title 18, U. S. C., Section 793 and  
794. Its transmission or the revelation of its contents  
in any manner to an unauthorized person is prohibited  
by law.\*

1. Reference: AR 1-26, subject, Senior Officer Debriefing Program (U)  
dated 4 November 1966.
2. Transmitted herewith is the report of BG Allan G. Pixton, subject as  
above.
3. This report is provided to insure appropriate benefits are realized  
from the experiences of the author. The report should be reviewed in  
accordance with paragraphs 3 and 5, AR 1-26; however, it should not be  
interpreted as the official view of the Department of the Army, or of  
any agency of the Department of the Army.
4. Information of actions initiated under provisions of AR 1-26, as a  
result of subject report, should be provided ACSFOR OT UT within 90 days  
of receipt of covering letter.

BY ORDER OF THE SECRETARY OF THE ARMY:

*Kenneth G. Wickham*

KENNETH G. WICKHAM  
Major General, USA  
The Adjutant General

1 Incl  
as

**DISTRIBUTION:**

Commanding Generals  
US Continental Army Command  
US Army Combat Developments Command  
US Army Materiel Command

Commandants

US Army War College  
US Army Command and General Staff College  
US Army Adjutant General School  
US Army Air Defense School  
US Army Armor School



Regraded unclassified when separated  
from classified inclosure.

DOWNGRADED AT 12 YEAR  
INTERVALS; NOT AUTOMATICALLY  
DECLASSIFIED. DOD DIR 5200.10

**CONFIDENTIAL**

AD506707

# CONFIDENTIAL

## DISTRIBUTION (Cont'd)

- US Army Aviation School
- US Army Civil Affairs School
- US Army Combat Surveillance School
- US Army Electronic Warfare School
- US Army Engineer School
- US Army Field Artillery School
- US Army Infantry School
- US Army Intelligence School
- US Army Missile and Munitions School
- US Army Ordnance School
- US Army Quartermaster School
- US Army Signal School
- US Army Southeastern Signal School
- US Army Special Warfare School
- US Army Transportation School

## Copies furnished:

- Office, Chief of Staff, US Army
- Deputy Chiefs of Staff
- Chief of Research and Development
- Assistant Chiefs of Staff
- Chief of Engineers
- The Surgeon General
- Chief of Military History
- The Provost Marshal General
- OSD(SA) Assistant for Southeast Asia Forces
- Director, Defense Research & Engineering
- Office, Joint Chiefs of Staff
- Commanders In Chief
  - Pacific
  - US Army, Pacific
- Commanding Generals
  - US Army Electronics Command
  - US Army Weapons Command
- III Corps
- Chief of Staff, USAF
- Deputy Chiefs of Staff, Air Force, Plans & Operations
- Chief of Naval Operations
- Commandant of the Marine Corps
- Commandants
  - Armed Forces Staff College
  - Defense Intelligence School
  - Industrial College of the Armed Forces
  - The National War College
- Senior Army Representative, Marine Corps Development & Education Command
- Project Manager, Naval Inshore Warfare Project Office
- USAF Air Ground Operations School
- The Air University Library
- Director, Weapons Systems Evaluation Group
- Defense Documentation Center

**CONFIDENTIAL**

**DISTRIBUTION (Cont'd)**

**Commanding Officers**

**US Army Limited War Laboratory**

**US Army Logistics, Doctrine Systems & Readiness Agency**

**US Army Mobility Equipment Research & Development Center**

**CONFIDENTIAL**

**CONFIDENTIAL**



**DEPARTMENT OF THE ARMY  
HEADQUARTERS, UNITED STATES ARMY VIETNAM  
APO SAN FRANCISCO 96375**

**17 DEC 1969**

**AVHGC-DST**

**SUBJECT: Senior Officer Debriefing Report  
BG Allan G. Pixton**

**Assistant Chief of Staff for Force Development  
Department of the Army  
Washington, D. C. 20310**

- 1. Attached are three copies of the Senior Officer Debriefing Report prepared by BG Allan G. Pixton. The report covers the period 2 September 1968 through 20 November 1969 during which time BG Pixton served as CG, XXIV Corps Artillery.**
- 2. BG Pixton is recommended as a candidate guest speaker at appropriate service schools.**

**FOR THE COMMANDER:**

**1 Incl  
as (trip)  
2 cy wd HQ, DA**

  
**L. D. MURRAY  
CPT, AGC  
Assistant Adjutant General**

**Regraded unclassified when separated  
from classified inclosure.**

**1**

**CONFIDENTIAL**

# CONFIDENTIAL

DEPARTMENT OF THE ARMY  
HEADQUARTERS, XXIV CORPS ARTILLERY  
APO San Francisco 96308

AVII-ATCG

19 November 1969

SUBJECT: Senior Officer Debriefing Report (RCS-CSFOR-74) (U)

Commanding General  
United States Army, Vietnam  
ATTN: AVIAG-DST  
APO San Francisco 96375

1. (U) Reference USARV Regulation 1-3 (C), dated 1 June 1969, subject: Senior Officer Debriefing Program (U).
2. (U) The many aspects of the insurgency problem here in Vietnam--the causative factors, the role of the US in countering the insurgency, the local military and political forces, and third country support--have all been well documented, and I have no significant contributions to add to this documentation. Rather, I will concentrate on the experience factors associated with my job as Commanding General, XXIV Corps Artillery.
3. (U) The challenges to the artillery have never been more demanding than in this war, for the Vietnam war for the artilleryman is primarily a battery war. For various reasons, battalions have more than the normal difficulties in controlling the fires of their batteries. This is caused by factors such as unusually large areas of operations, extreme variations in terrain, wide fluctuations in missions and tasks, and large geographic separation among battalion elements. The terrain factors and geographic separation of battalion elements are the most significant challenges to the artillery mission here in Northern I Corps Tactical Zone. The wide variations in terrain, from lowlands through the rolling piedmont areas to the mountainous jungle areas, have caused different employment concepts to be developed. The wide separation of units vastly increases the command and control problem, and the use of the helicopter for command and control purposes is an absolute necessity. A great deal of effort and pressure were required to obtain our assigned helicopter assets; the results have paid off handsomely.
4. (C) United States field artillery employment in the Northern area of the RVN has been characterized by the air mobile positioning of light and medium towed artillery and the semi-permanent positioning of self-propelled artillery. In addition, mobile armored task forces have been employed,

*FOR OT UT*  
*69B052*  
Inclosure

CONFIDENTIAL

1

DOWNGRADED AT 12 YEAR INTERVALS;  
NOT AUTOMATICALLY DECLASSIFIED.  
DOD MR 5200.10

## CONFIDENTIAL

AVII-ATCG

19 November 1969

SUBJECT: Senior Officer Debriefing Report (RCS-CSFOR-74)(U)

supported by light self-propelled artillery. Three such task forces have been organized by units of XXIV Corps during the past 15 months and have demonstrated that in Vietnam the self-propelled artillery can move and shoot in support of armored sweeps deep into enemy territory, as well as operate in the more conventional fire base role. Battery C, 1st Battalion, 40th Artillery (105SP), supported Task Force REMAGEN which conducted operations in the Khe Sanh and Vietnamese Salient areas in March and April 1969. Battery B, 1st Battalion, 40th Artillery, participated as part of Task Force MUSTANG in Operation UTAH MESA (U). The operation, conducted near Khe Sanh, and south and west to the Laotian border, began 12 June 1969 and terminated 8 July 1969. Battery A, 1st Battalion, 40th Artillery, supported the 3d of the 5th Cavalry operating on the floor of the A Shau Valley in July and August 1969.

5. (U) Corps Artillery has been responsible for the development of many operations plans involving the coordinated use of the various fire support means within XXIV Corps. Concepts and techniques were emphasized which would provide fast, efficient, tightly controlled fire support coordination between tactical air, artillery, and naval gunfire elements. Fire support procedures which streamlined coordination between the two division fire support elements and the USAF Tactical Air Control Parties have been very effective.

6. (C) With the initiation of the bombing halt on 31 October 1968 and the corresponding restrictions on artillery fires into and above the DMZ, a requirement was established to provide accurate data, on activities inside the DMZ, to the National Military Command Center and the Paris Peace Talks. Since the initiation of this reporting system, 10,540 sightings have been reported. These reports, by necessity, must be accurate and timely as they may affect national policy.

7. (U) The extremes of weather in XXIV Corps can be of major consequence in planning artillery operations. The record breaking rains and the two typhoons experienced during the reporting period have been a threat to installations and roads. Much effort has been expended to make roads to fire support bases passable and usable year round; however, in spite of these efforts, some damage has resulted from heavy rains. The rainfall for the month of October 1969 was phenomenal. On the fifth of October, Phu Bai had 21.65 inches of rain, setting a new all time record for any twenty-four hour period throughout all of South Vietnam. In the first seven days of the month, we had 58 inches of rain. The rainfall for the month of October 1969 was also record-setting, 75.3 inches in total. While Typhoon Bess in September 1968 required the relocation of some artillery units, subsequent preparation payed off, and during the deluge of rain this year, fire support operations continued with full effectiveness.

8. (U) Starting nearly a year ago, XXIV Corps Artillery instituted a program of designing and constructing standardized ammo bunkers and FDC

2

INCL

## CONFIDENTIAL

## CONFIDENTIAL

AVII-ATCG

19 November 1969

SUBJECT: Senior Officer Debriefing Report (RCS-CSFOR-74)(U)

bunkers for all Corps Artillery units. The bases for the pads were constructed of a heavy timber, either spiderweb design or a concrete base, covered by two layers of heavy timber decking, with timber or pole and earth revetments, and an extensive drainage system. The completed project provided an effective gun position, thus greatly improving efficiency and accuracy of the weapons system.

9. (U) The maintenance of heavy artillery improved significantly during the period. Several factors contributed to this improvement. One factor was the institution of a program of quarterly maintenance services, under which every heavy weapon was scheduled for 7 days maintenance at the direct support ordnance unit once per quarter. The gun crew accompanied the weapon and assisted ordnance personnel in accomplishing the required maintenance. A second factor was the assistance provided by two civilian technical representatives we were able to obtain, who worked with all heavy artillery units for several 90-day periods. The technical representatives trained crew members on the weapon in addition to performing technical inspections and serving the weapons. Another contributing factor was the increased responsiveness of the support system in term of both repair parts and maintenance. The overall availability rate of heavy artillery improved approximately 40% during the period.

10. (C) The use of the FADAC in XXIV Corps Artillery units has taken on increased importance. The need for fast, accurate artillery data has always been the goal of the artillerymen. The Corps Artillery units use the FADAC as the primary FDC data source. To do so there must be good assurance of availability of an operational FADAC system. The common maintenance and power requirement problems can be overcome with proper supervision, and the system can work with extreme reliability and with an increased operational rate, given the incentive and the proper command emphasis.

11. (U) In October 1968, the XXIV Corps Artillery Firing Battery Inspection Team (FBIT) was formed. The purpose of the inspection team is to provide a thorough and detailed technical gunnery proficiency examination of all artillery units with the Corps and to insure that defense measures for local security are adequate. The inspections identify areas of strength and weakness for the inspected unit, provide the parent unit with an outside agency evaluation of its batteries, and isolates those areas in which additional training emphasis is required. The inspections, which are conducted on a cyclic basis, have proven to be a great aid by providing each commander with a current and comparative evaluation of his batteries. Since the team was formed, 118 inspections of Army, Marine, and ARVN artillery units of XXIV Corps have been conducted. These included units of XXIV Corps, the 101st Airborne Division (AN), the 3d Marine Division, the 1st Brigade, 5th Infantry Division (Mech).

12. (C) The defeat of the enemy's anti-aircraft and field artillery capabilities in and around the DMZ, which culminated with Operation TIGR (U)

INCL

CONFIDENTIAL

## CONFIDENTIAL

AVII-ATCG

19 November 1969

SUBJECT: Senior Officer Debriefing Report (RCS-CSFOR-74)(U)

in July 1968, gave the Free World Forces almost uncontested access to aerial observation of enemy activity in and north of the DMZ. The bombing halt of 1 November 1968 restricted aerial observation north of the DMZ; consequently, knowledge of enemy disposition in the area has been correspondingly reduced. The enemy has shown an apparent intent to refrain from firing across the DMZ into South Vietnam. This has allowed a significant decrease in the 175mm counter battery capability along the DMZ and a corresponding increase in 8 inch capability by retubing assets. The increased 8 inch capability has allowed extension of the coverage envelope by that caliber. Throughout the AO long range heavy artillery is still continuously positioned to reach into an area well north of the DMZ, if necessary, as a hedge against the enemy threat and his capability for surprise attack.

13. (C) The use of sensor devices in the XXIV Corps area of operations is being exploited for target acquisition. Because of the DMZ activity and the infiltration problems it presents, increased emphasis has been placed on sensors for intelligence purposes. In addition, placements of sensor strings are being made with the fire support requirement in mind. There is evidence that sensors used in the target acquisition role have been effective; however, battle damage assessment is limited. This is due in part to the circumstances surrounding sensor employment and in part to the enemy's practice of removing his dead from the battlefield. Information from the reports of sensor operations indicate that the program is achieving good results. An illustrative example was a sign on a trail near a sensor string, which was written in Vietnamese, stating, "Danger, mines. If you go down this trail, you will be blown up." Since there were no mines along the trail, the sign was undoubtedly posted as a result of artillery interdiction which responded to sensor target acquisition. Blood trails and bodies have been discovered in sensor monitored areas after our artillery has fired into the areas. The ARVN units here are being extensively trained in this program and have shown promising insight into the employment of these devices.

14. (C) The coordination and mutual respect achieved between Army, Marine, and ARVN artillery units has been most gratifying. There has been a free exchange of ideas between all agencies and a close harmonious working relationship which has been generated at Corps Artillery level and has permeated throughout the command. Combined US/ARVN operations have been conducted with both US and ARVN artillery units supporting the combined maneuver elements. US forward observers and liaison teams have been and continue to be provided to ARVN maneuver and artillery units. ARVN liaison teams and fire support coordination personnel have been and continue to be collocated with US units. The steps taken in this area by USA, USMC, and ARVN commanders at all levels have been instrumental in achieving success on the battlefield and in furthering the joint goal of Vietnamization of the war.

4

CONFIDENTIAL

# CONFIDENTIAL

AVII-ATCG

19 November 1969

SUBJECT: Senior Officer Debriefing Report (RCS-CSFOR-74)(U)

15. (U) The manifold accomplishments of the XXIV Corps Artillery in combat, and the increase in operational, logistic, and training capabilities are a direct result of the diligence and professionalism of its officers and men. During my period of command, XXIV Corps Artillery units participated in numerous major operations such as SCOTLAND II (U), MARSHALL MOUNTAIN (U), DEWEY CANYON (U), NEVADA EAGLE (U), JEB STUART III (U), MASSACHUSETTS STRIKER (U), KENTUCKY JUMPER (U), and APACHE SNOW (U). Corps Artillery units met the challenge and performed in an outstanding manner in every operation, regardless of the difficulties of environment and vast distances over which units were dispersed. Corps Artillery units delivered 1,011,140 rounds of all calibers against enemy positions. These operations produced heavy damage on enemy personnel and equipment. XXIV Corps Artillery units were credited with 3,079 bunkers destroyed, 28 artillery pieces destroyed and 23 damaged, 1,422 secondary explosions, 1,479 confirmed enemy kills, and 278 probable kills. We have employed our artillery into heretofore untouched enemy sanctuaries and have welded the diverse multinational and multiservice units into a highly effective fire support mechanism. These successes have contributed significantly to the United States counterinsurgency effort in the Republic of Vietnam.

- 5 Incl
1. Administration.
  2. Intelligence.
  3. Operations.
  4. Logistics.
  5. Civic Action.

*Allan G. Pixton*

ALLAN G. PIXTON  
Brigadier General, USA  
Commanding

## ADMINISTRATION

1. Throughout the cited period the administrative and personnel areas of main interest were those of the infusion program, and the return to CONUS of the 2d Battalion, 138th Artillery (Operation CLEAR ADJUST (U)).

### 2. Infusion Program:

a. The purpose of the infusion program was to retain unit continuity and mission capability by reducing the impact of rotational losses. The infusion program for the 2d Battalion, 138th Artillery, as directed by Headquarters, USARV, was started in February 1969 and was to be completed NLT 60 days prior to the first anniversary (October 1969) of the unit's arrival in the RVN. The authorized strength for the battalion was 494 EM and 42 officer/warrant officers, and the unit was required to infuse 305 EM and 31 officer/warrant officers.

b. Informal coordination with 101st Airborne Division (AM) to determine if they could accept any October losses proved to be negative; however, the Americal Division was able to assist in the infusion because it had an excessive number of personnel scheduled to rotate in July. The necessary steps were taken in accordance with USARV Regulation 614-9 to infuse 75 EM between the two units, and the infusion was completed in March 1969. In April 1969, 100 EM were infused with the 108th Artillery Group. At the end of this phase it was necessary to go to Headquarters, USARV, for assistance. A program of infusion by replacement stream personnel was set up which would complete the program by the end of July 1969. At this time the October "hump" would be reduced to approximately 20%. However, on 5 July, Headquarters, USARV, directed that the infusion program cease because of the development of plans to release National Guard and reserve units.

c. The infusion of the officers was handled on a case-by-case basis within Corps Artillery. The program was directed by the Corps Artillery S1 and officers were infused with Headquarters, XXIV Corps; Headquarters, 108th Artillery Group; and Headquarters, XXIV Corps Artillery. A planned replacement program was established to prevent any losses which would jeopardize the mission of the battalions. This program was highly successful.

d. The infusion program created a morale problem in that personnel who came on active duty with the 2d Battalion, 138th Artillery, and who had in many cases extremely close ties to the unit and to personnel within the unit, were now being transferred out of the unit. The battalion commander quickly recognized this problem, and through personal contacts, visits to units, and a well-written letter to all the men of the unit, he was able to explain the purpose and need for the infusion program.

### 3. Operation CLEAR ADJUST (U):

a. After the infusion program phase had ended, Headquarters, USARV, directed that the 2d Battalion, 138th Artillery, would depart the RVN and

Inclosure 1

be replaced by the 1st Battalion, 39th Artillery (Operation CLEAR ADJUST (U)). The residual members of the 2d Battalion, 138th Artillery, would form the nucleus of the 1st Battalion, 39th Artillery. In August 1969, messages were dispatched by Headquarters, USARV, directing that all former members of the 2d Battalion, 138th Artillery, be returned to their unit NLT 25 September 1969. A redeployment center was set up in Phu Bai, and the original battalion commander was put in overall charge of the operation. Necessary plans were developed for processing and departure ceremonies.

b. A major source of assistance during Operation CLEAR ADJUST (U) was reports of lessons learned from Operation KEYSTONE EAGLE (U). The need for checklists and centralized outprocessing facilities was recognized as being extremely important for a smooth operation. The USARV Redeployment Assistance Teams (URAT) were also found to be of great help in resolving problem areas that were not otherwise amenable to solution. The overall operation for the return of the 2d Battalion, 138th Artillery, was highly successful. Some areas of interest encountered and solved during the operation were:

(1) A message was sent to Headquarters, USARV, requesting that the entire unit depart Vietnam NLT 10 October. This was necessary since the original plan required the advance party to DEROS on 10 October and the main body on 24 October. It was felt that the overall objective of the program would be better met if the entire unit departed at one time. This request was approved.

(2) During the early planning for Operation CLEAR ADJUST (U), Headquarters, USARV, directed that awards would not be presented in the RVN but would be saved and presented at appropriate ceremonies in CONUS. Corps Artillery did not concur with this policy and submitted a request for reconsideration. It was felt that this policy would have an adverse effect on morale and esprit for several reasons: first, mass presentation of awards detracts from the individual pride of receiving an award; second, some persons would not receive an award, and therefore presentation as directed by USARV would tend to call attention to such individuals; third, the wearing of awards upon arrival in CONUS would add to the personal pride of the individual soldier and also create a better military image. The USARV policy was revoked in a later message, and all processed awards were presented in Vietnam in accordance with previous practice. As it turned out, there were sufficient late award recommendations, especially in the case of infused personnel, to provide a residual for presentation in CONUS, thereby effectively meeting both objectives.

(3) One problem that resulted from the departure of the 2d Battalion, 138th Artillery, was an impending critical personnel shortage in the remaining unit. An immediate request was sent to USARV requesting that the 1st Battalion, 39th Artillery, be given priority for enlisted replacements. It was proposed that in order to avoid a critical shortage replacement buildup prior to redeployment was necessary. However, in order not to

create an additional rotational hump the following year, it was necessary to program the replacement flow over a period of several months. This program produced the desired results, for the 1st Battalion, 39th Artillery, has not had any serious personnel problems and has been able to perform its mission at all times.

(4) An additional lesson was learned in the area of achievement and service awards. Recognizing that infused personnel would be at a disadvantage in their new units, the battalion was careful to include in appropriate personnel records a statement of the man's accomplishment to date and a recommendation that at the appropriate time he be considered for an award by his new unit. When personnel returned to their original unit for return to CONUS, however, it was found that this program had met with only partial success and that many deserving individuals had not received awards. Personal visits to the units by officers from the original battalion served to produce some needed award recommendations. In other cases, award recommendations were processed by this headquarters after reassembly of the unit for return to CONUS. In any future infusion programs this aspect of the operation should receive special attention since it impacts directly on morale.

4. In line with this program of awards and the presentation, Corps Artillery has received from XXIV Corps the authority to approve awards for the Bronze Star, the Air Medal, and the Army Commendation Medal. This authority is normally retained at Corps level. It has been an extremely effective program and has enabled the staff to monitor the program and insure uniformity, thereby giving meaning to the awards program within Corps Artillery units.

5. Aviation. Another area of extreme importance was the lack of sufficient organic air transportation in Corps Artillery prior to May 1969. Through the efforts of the CG, XXIV Corps Artillery, in coordination with CG, 1st Aviation Brigade, and the Chief of Staff, XXIV Corps, Corps Artillery received two UH1's and three OH6A's (LOH). These ships were maintained by the 62d Aviation Company at Phu Bai. The scheduling of the assets was done by the Corps Artillery S1. Previous to this, Corps Artillery was fortunate to get one LOH a day. These extra ships have enabled the Corps Artillery staff to conduct increased liaison work and have enabled Corps Artillery to support the 108th Artillery Group and two attached artillery battalions when the need arises.

# CONFIDENTIAL

## INTELLIGENCE

1. a. Target acquisition was of utmost importance in the effective utilization of artillery fires. The widely diverse and varied terrain in the XXIV Corps area of operations, from the coastal lowlands along the South China Sea through the piedmont area and into the mountainous jungle with its double and triple canopy and almost impenetrable undergrowth, presented particularly intriguing and challenging target acquisition problems.

b. The area in extreme northeastern Quang Tri Province, known familiarly as Leatherneck Square, presented a more conventional combat aspect than any other area in the Republic of Vietnam. In this area, the more traditional target acquisition devices were emplaced, generally along the southern trace of the De-militarized Zone (DMZ). Flash and sound bases were established and counter-battery radars emplaced. The employment of ground surveillance radars in this area provided an invaluable means of providing surveillance of the eastern DMZ during periods of darkness and reduced visibility.

c. The key to effective employment of these target acquisition devices was close and continuous coordination, not only with the supported force, but with other, mutually supporting target acquisition means as well. Sectors of search and coverage were based on the best local intelligence in order to maximize the inherent limited capabilities of present day target acquisition means.

d. Aerial target acquisition was essential to complement other target acquisition sources. In some areas the acquisition capability of forward observers with the maneuver forces was extremely handicapped by the heavy undergrowth and limited fields of observation. In the DMZ, aerial target acquisition was limited by the requirement to fly south of the provisional military demarcation line. Despite these limitations, the use of aerial observers provided a significant contribution to the artillery intelligence effort by maintaining a constant watch in the area habitually used by the enemy.

e. The use of the AN/TPS-25 ground surveillance radar along the southern trace of the DMZ materially assisted in maintaining surveillance of the eastern DMZ where line-of-sight limitations are minimized. Although enemy infiltration continued through this area, constant surveillance by artillery target acquisition devices kept it at a greatly reduced level.

f. The employment of ground sensing devices represented a major breakthrough in artillery target acquisition, as well as combat intelligence and surveillance. Sensor fields, planned and emplaced with the fire support capabilities in mind, produced outstanding results. The artillery actively assisted in sensor utilization and employment planning to insure that maximum benefit was derived from targets detected.

2. a. Since most artillery fires delivered in the XXIV Corps area of operations were unobserved, the most accurate firing data possible had to be developed. It was found that the Metro Quality Control Team made a

## CONFIDENTIAL

significant contribution in this respect. The team instituted a program of systematic checks of meteorological flights flown daily in the Corps area, resulting in exceptionally accurate data. When the program was instituted in September 1968, units were completing only 63% of the required flights. Of this number, 24% were judged unsatisfactory. During subsequent months the number of flights flown increased with a concomitant decrease in unsatisfactory flights. The latest figures indicated that units were completing 94% of the required flights with only a 2% error rate.

b. In the Vietnam combat environment, metro stations were forced to operate on an area basis rather than a unit basis. A continual evaluation of metro station locations was made and sections were relocated when necessary to provide the most accurate metro data possible for the artillery with the Corps. Where a large difference in altitude existed between a fire support base and the servicing metro station, the use of a supplemental mountain met team at the support base proved extremely effective and was employed whenever necessary.

3. The Target Information Center proved to be an effective means of collecting and evaluating hard or non-fleeting type target information for use by all units in XXIV Corps. Target information was collected from all available sources, and was stored on punched cards and updated machine record lists published monthly with changes as necessary. Entries were deleted from the target list based on correlation with battle damage assessment reports and age of the target. Since September 1968, 5,752 targets in the XXIV Corps area of operation have been processed. A target list, produced by the Target Information Center, was used effectively by subordinate units for flak suppression, artillery raids, and special operations.

4. a. In the XXIV Corps area of operation the survey capability of the battalion survey sections was extremely limited by the terrain and an almost complete lack of road networks, except in the narrow coastal lowlands. The Distance Measurer, Electronic (DME), which is organic to the division artillery and the target acquisition battery proved to be invaluable in extending survey control into fire support bases.

b. The Survey Information Center (SIC) provided valuable technical advice and assistance to artillery units in the XXIV Corps area of operations. The use of the FADAC computer to provide a quality control check of field computations significantly improved survey data for use by subordinate units. In the past year the SIC published a trig list and subsequently a revised edition to provide wide dissemination of available survey data.

c. In October 1968, at the request of CG, Corps Artillery, high order survey control points were established by the 569th Engineer Company (Topo) at key locations along Highway QL1 from Fire Support Base Los Banos to Dong Hia Combat Base. These control points provided a basis for the common control

## CONFIDENTIAL

established throughout the XXIV Corps area of operation. During January 1969, the plan was further developed to provide improved registration capabilities. At key locations, to include all occupied fire support bases, survey control points were recovered or established in other locations. These survey control points allowed high burst registrations throughout most of the Corps area of operation and did much to enhance the accuracy of fires.

5. The utilization of ground sensing devices has been the most important, single advancement in artillery target acquisition in many years. In Vietnam, aggressive and imaginative employment planning and close, continuous coordination between Ground Surveillance Officers and supporting artillery units were essential to achieve the most effective utilization of sensor developed target acquisition data. By knowing the precise location of sensor strings and careful selection of kill zones, effective artillery fires were planned and delivered in a timely manner. Results obtained from the employment of ground sensing devices to date have been encouraging, in terms of both combat intelligence and artillery target acquisition. It has been, however, only a beginning. Continued imaginative planning and aggressive employment will be required for full, effective development of the ground sensor program.

//

CONFIDENTIAL

# CONFIDENTIAL

## OPERATIONS

### 1. General:

a. The mission of XXIV Corps Artillery was to provide general support to the Corps, including counter-battery fires into and north of the DMZ and Laos. The organization of XXIV Corps Artillery for the period 2 September 1968 through 20 November 1969, is shown at Appendices 1, 2, and 3.

b. XXIV Corps Artillery provided fast, accurate, and effective fire support to the 1st Cavalry Division (AM), the 3d Marine Division, the 101st Airborne Division (AM), and the 1st ARVN Division.

### 2. XXIV Corps Artillery provided support to the 1st Cavalry Division (AM) for the following operations:

a. JEB STUART III (U) and COMANCHE FALLS (U) - fall of 1968. These were cordon and search operations characterized by air assaults and rapid deployment of forces. Corps Artillery supported these operations from FSB Nancy (YD4339) and FSB Jeannie (YD5438).

b. LIBERTY CANYON (U) - fall of 1968. This operation was the redeployment of the division to the III Corps Tactical Zone.

### 3. XXIV Corps Artillery provided support to the 3d Marine Division (Reinf) for the following operations:

a. LANCASTER II (U) - fall of 1968. This operation was a cordon and search operation conducted in the Khe Sanh (XD8541) area.

b. SCOTLAND II (U), KENTUCKY (U), DEWEY CANYON (U), and MARSHALL MOUNTAIN (U) - fall and winter of 1968-1969. These operations were search and clear and cordon operations, supported in most cases by firing batteries located on mountaintop fire support bases.

c. PURPLE MARTIN (U), MONTANA MAULER (U), and MAINE CRAG (U) - spring of 1969. These operations were search and clear and cordon operations conducted along the DMZ.

d. Task Force REMAGEN - spring of 1969. This task force, a subordinate element of Task Force HOTEL, supported by Battery C, 1st Battalion, 40th Artillery, conducted a fast moving RIF operation in the area from Khe Sanh west to the Laotian border and south to the Vietnam salient. This operation was unusual in that the battery moved with the armored infantry forces throughout the operation, establishing firing positions wherever required.

e. VIRGINIA RIDGE (U), HERKIMER MOUNTAIN (U), CAMERON FALLS (U), MASSACHUSETTS BAY (U), IROQUOIS GROVE (U), ARLINGTON CANYON (U), GEORGIA

## CONFIDENTIAL

TAR (U), WILLIAMS GLADE (U), and FULTON SQUARE (U) - summer and fall of 1969. These operations were search and clear, cordon, and rice denial operations conducted throughout the northern portion of XXIV Corps Area of Operations.

f. UTAH MESA (U) - summer of 1969. This operation was conducted by Task Force MUSTANG in the Khe Sanh area. The operation was supported by Battery B, 1st Battalion, 40th Artillery, and was similar in execution to the operation conducted by Task Force REMAGEN.

g. In the fall of 1969, the withdrawal of the 3d Marine Division was announced. The initial stage of the withdrawal started on 21 September 1969 and the last artillery battery (Battery H, 3d Battalion, 12th Regiment) stood down on 5 November 1969. During the entire period of the withdrawal, Corps Artillery units provided fire support and fire support coordination to insure the safe extraction of the division.

h. Corps Artillery units supported the above operations from FSB A-2 (YD2174), FSB A-4 (YD1170), FSB C-1 (YD2167), FSB C-2 (YD1264), Camp Carroll (YD0654), FSB Mai Loc (YD0951), Elliott Combat Base (XD9854), Vandegrift Combat Base (XD0049), FSB Ca Lu (XD9854), FSB Cates (XD9243), FSB Khe Sanh (XD8541), FSB Snapper (XD8434), FSB Saigon (XD8227), Dong Ha Combat Base (YD2259), FSB Cua Viet (YD3469), FSB Jack (YD4928), FSB Tombstone (YD3958), FSB Nancy (YD4339), and many temporary positions during the conduct of Task Force REMAGEN and MUSTANG.

4. XXIV Corps Artillery provided support to the 101st Airborne Division (AM) for the following operations:

a. NEVADA EAGLE (U) - fall and winter of 1968. This was a cordon and search operation conducted in conjunction with the 1st ARVN Division and RF/PF forces to deny food to the NVA and to destroy the VC infrastructure in Thua Thien Province. The operation was supported by the 1st Battalion, 83d Artillery, and Battery B, 6th Battalion, 33d Artillery.

b. RAWLINS VALLEY (U), TODD FOREST (U), PLATTE CANYON (U), OHIO RAPIDS (U), and SHERMAN PEAK (U) - winter of 1968 and 1969. These operations were directed against enemy base areas (110, 114, and the Ruong Ruong Valley), and were joint RIF operations.

c. SPOKANE RAPIDS (U) and MASSACHUSETTS STRIKER (U) - spring of 1969. These operations were RIF operations conducted in conjunction with the 1st ARVN Division against enemy base areas. The area of operation for the division was enlarged due to the opening of the road into the Ruong Ruong Valley and the extension of route 547 towards the A Chau Valley.

d. BRISTOL BOOTS (U) - spring of 1969. This was a land assault into the Ruong Ruong Valley which extended the division AO into Quang Nam Province. This operation was preceded by a series of artillery raids, using

## CONFIDENTIAL

divisional 105 artillery units plus Batteries B and C, 2d Battalion, 138th Artillery, and Batteries B and C, 1st Battalion, 83d Artillery, which were designed to deceive the enemy into thinking that maneuver forces would not follow the artillery raids.

e. KENTUCKY JUMPER (U) - spring and summer of 1969. This was a joint cordon and search, resource denial, and security operation northeast of the A Shau Valley.

f. APACHE SNOW (U) - spring of 1969. This was a RIF operation in the northern A Shau Valley to find and fix the 29th NVA Regiment and provide security for route 547. The operation resulted in the destruction of the regimental base camp on Hill 937.

g. MONTGOMERY RENDEZVOUS (U) and CAMPBELL STREAMER (U) - summer and fall of 1969. These operations were RIF operations conducted in the northeast of the A Shau Valley and into the Elephant Valley respectively.

h. REPUBLIC SQUARE (U) - fall of 1969. This operation was necessitated by the announced withdrawal of the 3d Marine Division, the requirement to screen the western flank of the 3d Marine Division, and the need to deny food to the NVA.

i. During the summer and fall of 1969, Corps Artillery units were positioned to support operations into the A Shau Valley. Battery A, 1st Battalion, 83d Artillery, was able to move the first heavy artillery piece into the A Shau Valley using the newly completed route 547. Battery A, 1st Battalion, 40th Artillery, supported the 3d Squadron, 5th Cavalry, during operations throughout the A Shau Valley.

j. Corps Artillery units provided support for the above operations from FSB Nancy (YD4339), FSB Jeannie (YD5539), FSB Jack (YD4928), Camp Evans (YD5332), FSB Sally (YD6427), FSB T-Bone (YD6520), Gia Le Combat Base (YD8315), Phu Bai Combat Base (YD8813), FSB Arrow (YD8010), FSB Boyd (YD7413), FSB Birmingham (YD7010), FSB Bastogne (YD6209), FSB Blaze (YD5302), FSB Cannon (YD4703), FSB Rendezvous (YC4396), FSB Currahee (YC3994), FSB Thor (YC6683), FSB Anzio (YD9307), FSB Quick I (YD9003), FSB Barracuda (YD8999), FSB Rifle (YC8698), FSB Hank (YC9188), FSB Fist (YC8884), FSB Slege (ZCQ692), FSB Roy (ZD0503), FSB Tomahawk ZD1101, Hill 88 (AU8001), FSB Los Banos (AU8300), and FSB Beach (AT8798).

5. XXIV Corps Artillery provided support to the 1st ARVN Division as follows:

a. The division had its four regiments assigned to specific areas of operations starting with the 2d Regiment along the DMZ, the 1st Regiment, the 3d Regiment, and finally the 54th Regiment in the southern portion of the XXIV Corps Area of Operations. The majority of operations conducted in the XXIV Corps Area of Operations were joint US and ARVN operations.

## CONFIDENTIAL

## CONFIDENTIAL

b. Corps Artillery provided reinforcing fires to the 1st ARVN Division for all operations. In addition, an average of 7 FO and 3 LNO teams were provided to ARVN units on a continuing basis.

c. The spring of 1969 saw the deployment of the 1st ARVN Division Artillery as full batteries in roles consistent with US artillery principles. The activation of the 14th Artillery Battalion in September 1969 expanded the Division Artillery and provided a direct support artillery battalion for each of the maneuver regiments.

6. XXIV Corps Artillery expended 1,011,140 rounds of artillery ammunition during the period 2 September 1968 through 20 November 1969, resulting in the following Battle Damage Assessment:

	<u>Confirmed</u>	<u>Probable</u>
a. Killed by artillery	1479	278
b. Bunkers destroyed	3079	-
c. Bunkers damaged	1095	-
d. Structures destroyed	428	-
e. Structures damaged	122	-
f. Trench line destroyed (m)	8190	-
g. Secondary explosions	1422	-
h. Secondary fires	142	-
i. Rocket Positions destroyed	100	-
j. Rocket positions damaged	12	-
k. AA positions destroyed	36	-
l. AA positions silenced	15	-
m. Arty positions destroyed	66	-
n. Arty positions damaged	60	-
o. Mortar positions destroyed	14	-
p. Mortar positions silenced	15	-
q. AW positions destroyed	29	-
r. AW positions silenced	5	-

CONFIDENTIAL

## CONFIDENTIAL

	<u>Confirmed</u>	<u>Probable</u>
s. Trucks destroyed	4	1
t. Bridges destroyed	5	-
u. Sampans destroyed	9	-
v. Tunnels destroyed	1	-

### 7. Training:

a. XXIV Corps Artillery established a Firing Battery Inspection Team (FBIT) on 5 October 1968. The team, composed of personnel from the S3 section, was initially organized to inspect Corps Artillery firing batteries. The objectives of the inspection were to identify areas of strength and weakness for the inspected unit, to provide the parent unit with an outside agency evaluation of its batteries, and to upgrade firing battery and gunnery performance, particularly in techniques used only occasionally. After the team's inception, its inspections expanded until they included all US and ARVN artillery batteries in XXIV Corps. Over 100 inspections have been conducted thus far. The FBIT has proved to be a valuable tool for maintaining high standards and proficiency, for collecting and disseminating ideas for improvement in firing battery, fire direction, and local security matters.

b. Many junior officer replacements arriving in Vietnam required additional training in observer and fire direction techniques peculiar to artillery employment in Vietnam and particularly in XXIV Corps. FO and FDO schools were established by XXIV Corps Artillery to provide this required training for Corps Artillery units and also for the Artillery units with the Corps. A week-long course of instruction in each area was conducted each month.

c. The receipt of the Gun Direction Computer, M18 (FADAC), by Corps Artillery units greatly enhanced the overall capabilities of the fire direction centers. Continued emphasis was placed on the training and use of FADAC as the primary source of firing data. This emphasis evolved into individual battery and battalion training programs whereby all FDC personnel became proficient in the operation of FADAC.

8. Tactical techniques. It was found that the heavy artillery battery did not possess the capability to deploy by platoon for an extended period of time due to lack of personnel and equipment. However, a great deal of success was achieved in conducting one or two gun short term heavy artillery raids. Under these conditions, the battery FDC remains intact at the battery (-) position area and fire commands were transmitted to the forward area via radio. The raid weapons were accompanied to the forward area by the XO, section personnel, ammunition handlers, and a security element large enough to secure the position area.

## CONFIDENTIAL

### 9. Firing battery techniques:

a. As a result of the soil instability in the RVN, particularly during the rainy season, a standardized permanent wooden or concrete heavy gun pad was designed and constructed throughout XXIV Corps. These gun pads not only provided a level, stable firing platform, but also minimized damage to the weapons. When the gun pads were provided with proper drainage and spade support, a near ideal situation existed for the emplacement of heavy artillery.

b. As a secondary check of deflection physically placed on the M108 and M109 howitzers, a turret ring azimuth check system was developed. The system consisted of placing permanent azimuth marks at 100 mil intervals on the turret ring along with an adjustable index. After laying the howitzer on the primary direction of fire (a direction different from the base deflection of 3200 mils), the azimuth marks were numbered with a grease pencil and the adjustable index was centered on the direction of fire. On receipt of a fire mission, the gunner set off the announced deflection and quadrant. The chief of section verified these settings and reported charge, azimuth, and quadrant to the XO with a check of deflection for each gun as far as gunner errors or sight slippage.

### Appendices:

17

1. XXIV Corps Artillery organization - 2 Sep 68.
2. XXIV Corps Artillery organization - 10 Oct 69.
3. XXIV Corss Artillery organization - 20 Nov 69.

CONFIDENTIAL

XXIV CORPS ARTILLERY ORGANIZATIONAL STRUCTURE - 2 SEPTEMBER 1968

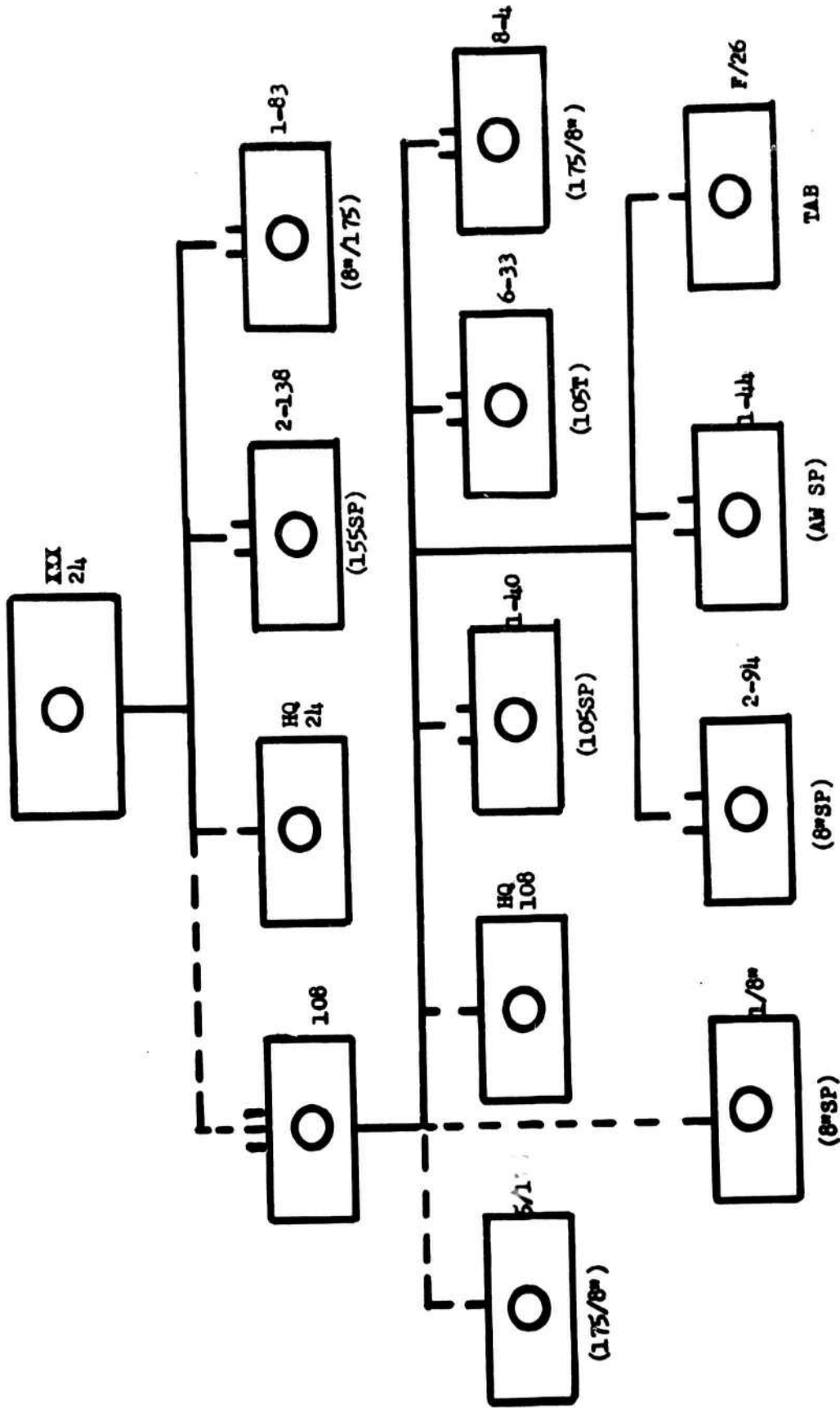

----- OFCOM

**XXIV CORPS ARTILLERY ORGANIZATIONAL STRUCTURE - 10 October 1969**

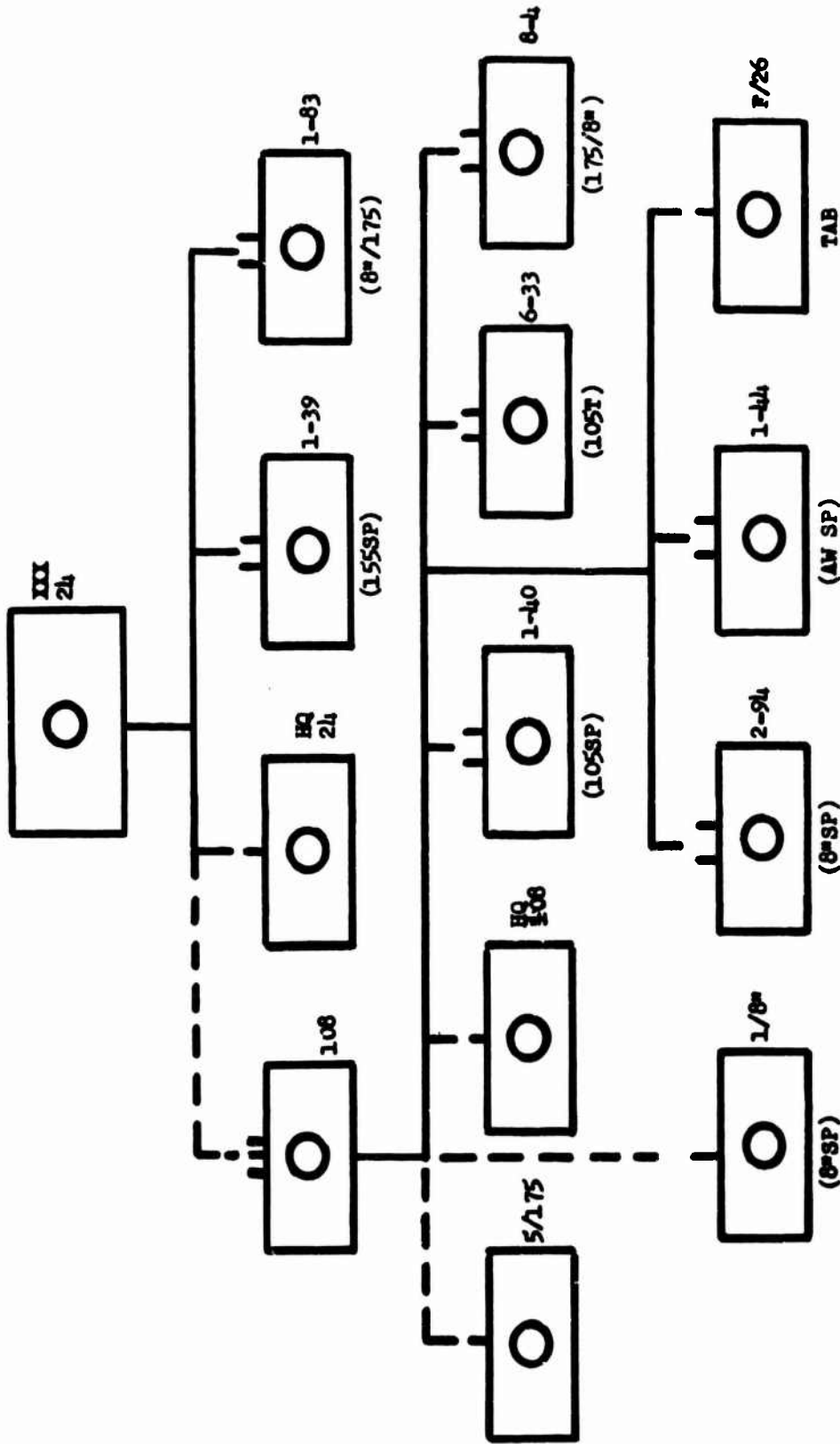

**NOTE:** The 2d Bn, 138th Arty was redeployed to COMUS on 10 October 1969. The battalion was redesignated as the 1st Bn, 39th Arty.

- - - - - OFCOM

**XIV CORPS ARTILLERY ORGANIZATIONAL STRUCTURE - 20 NOVEMBER 1969**

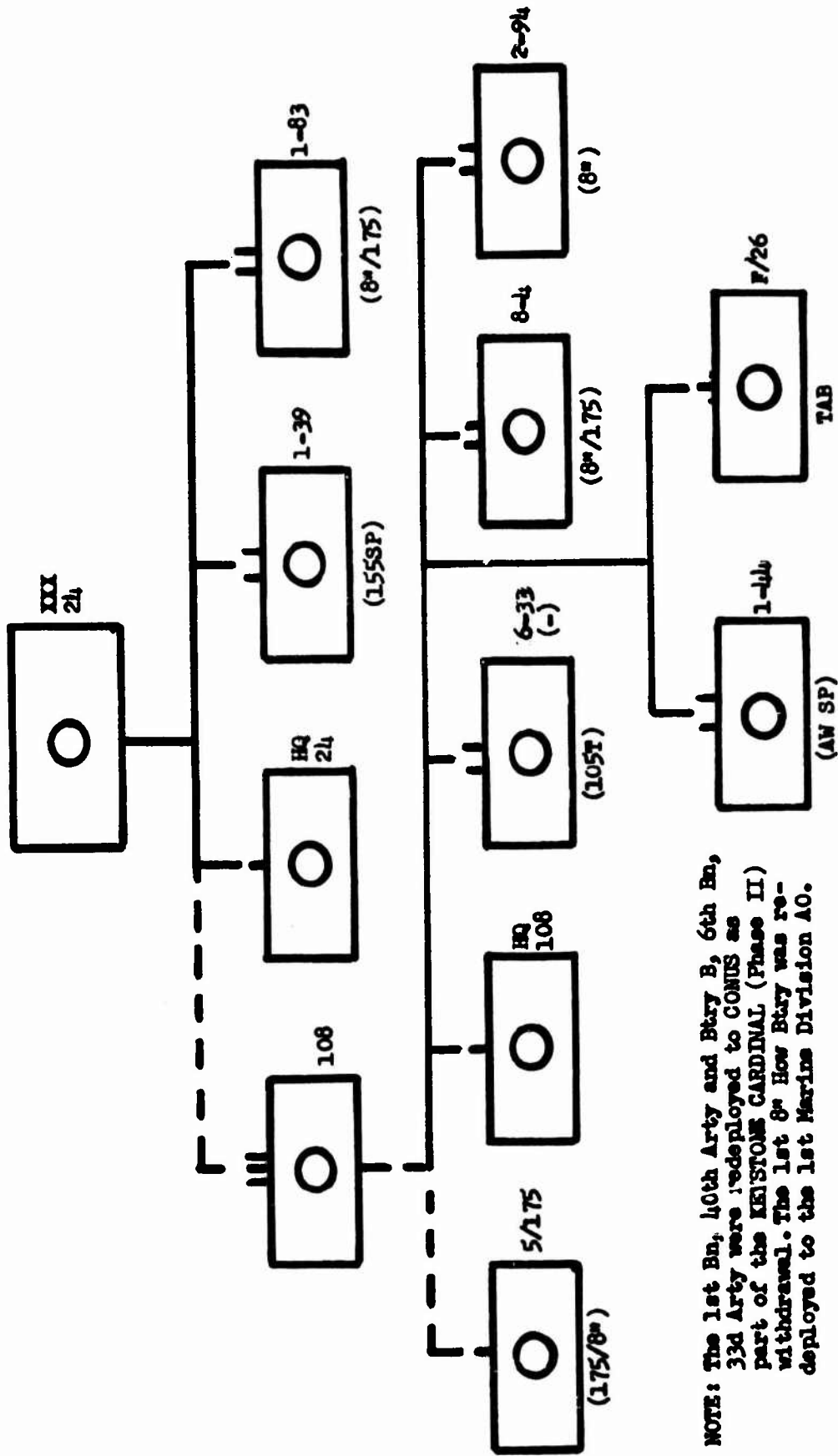

**NOTE:** The 1st Bn, 40th Arty and Btry B, 6th Bn, 33d Arty were redeployed to COMUS as part of the KEystone CARDINAL (Phase II) withdrawal. The 1st 8\* How Btry was redeployed to the 1st Marine Division AO.

----- OFCOM

LOGISTICS

1. General. Logistic support was provided to XXIV Corps Artillery by the 1st Logistical Command through the Support Command, Da Nang, and the 26th General Support Group in Phu Bai. Direct support maintenance, supply and service, ammunition, and other logistical units were located in Phu Bai, Quang Tri, and other areas of troop concentration.

2. Maintenance:

a. Maintenance of vehicles, weapons, and other equipment was a problem that demanded close attention in XXIV Corps Artillery. The extremes of weather conditions plus the very heavy usage and the frequent turnover of personnel were factors that compounded the maintenance problem. Two particularly critical areas were heavy artillery and generators.

b. In the matter of heavy artillery, the lack of experience personnel and the frequency of personnel turnover appeared to be the most serious problems. In the heavy cannon batteries the chiefs of section, more often than not, came to the units with no experience in heavy artillery. During the summer and early fall of 1969, two civilian technical representatives were made available by the 1st Logistical Command. These two individuals, skilled and highly motivated, spent approximately 90 days working with the heavy cannon batteries, instructing battery personnel on all aspects of the weapon system, leading them through a thorough inspection of their weapons, and establishing contact teams from battalion resources. The technical representatives also effected the retrograding of several weapons that were no longer economically repairable in Vietnam, and in general brought the maintenance practices and procedures up to an acceptable level before the advent of the rainy season.

c. An additional maintenance device introduced in Corps Artillery heavy cannon battalions was a system of quarterly maintenance services. Under this system, every heavy gun within Corps Artillery was scheduled to be evacuated to the appropriate direct support maintenance unit for a seven day period each quarter. The gun crew accompanied the weapon to the shops and assisted ordnance personnel in performing the requisite maintenance services. This system helped significantly to keep the weapons operating satisfactorily.

d. With respect to generators, particularly generators powering FADAC and radar systems, the most serious problems were caused by heavy usage, age of equipment, and lack of experienced personnel. The heavy usage, especially of the generators that powered the radar systems, was a fact of life that could not be changed; however, Corps Artillery was able to obtain additional generators through logistical channels so that generators on remote radar sites could be operated alternately, thus permitting an adequate period for rest and maintenance. A civilian technical representative worked with Corps Artillery for several months during the summer

Inclosure 4

and fall of 1969. This individual spent the bulk of his time in the field working with generator operators, mechanics, and warrant officers; his presence helped considerably to raise the level of generator maintenance in Corps Artillery.

e. During this period, the Corps Artillery was responsible for organizing and operating the Corps CMMI Team. Organized in late 1968, the team originally inspected only Corps Artillery units. In mid-1969, however, the team added the Corps Headquarters Company and the 108th Transportation Company to its inspection schedule. Units were inspected within a 6-month period, with each unit given 24 hours notification before the arrival of the CMMI team. Units that were given an unsatisfactory rating were reinspected within 30 days to insure that deficiencies were being corrected.

### 3. Supply:

a. The supply system in general worked well, especially considering the fact that XXIV Corps Artillery lay at the extreme end of the supply line. There were, however, certain items of equipment that remained chronically short: 5-ton trucks and M-548 cargo carriers were two such items. These vehicles were especially critical in that they were used for daily resupply of ammunition and other items to the firebases.

b. In 1968, a system was developed by the Commanding General, 1st Logistical Command to expedite delivery of needed equipment to the units. This system was the Commanders Critical Items List (CCIL), under which each battery sized unit commander compiled a semi-monthly list of equipment that he deemed critical to his operation. The lists were forwarded to Corps Artillery where they were scrutinized to insure that the items were in fact critical, and then the lists were sent to 1st Logistical Command. The policy in 1st Logistical Command was to act on every item within 24 hours after receiving the list. Items that were available in Vietnam were released and shipped to the requesting unit, while CONUS depots were tasked to ship expeditiously all items not available in Vietnam. The CCIL system was extremely effective in reducing shortages of equipment, but it had to be monitored closely to insure that batteries were forwarding only items truly critical on their lists.

## CIVIC ACTIONS

1. XXIV Corps Artillery units actively and aggressively participated in the GVN pacification program. The Corps Artillery was not authorized an S5 by TOE, nor were the subordinate units, but officers were tasked with S5 responsibilities at all levels of command. Because firing batteries were normally sited on relatively isolated fire support bases, the main burden for civic action activities fell upon the headquarters and service batteries.
2. Medical Civic Action Programs were a vital part of the overall Corps Artillery civic action plan. MEDCAP's were conducted by all battalions throughout Quang Tri and Thua Thien provinces. The aim of the program was not only to treat the sick and suffering, but to provide education and guidance for the indigenous medical personnel. Diagnosis and treatment were normally performed at the MEDCAP site, with cases of serious illness evacuated to civilian hospitals or even to US Army hospitals or US Navy hospital ships. Corps Artillery MEDCAP's contributed much to the health and welfare of the Vietnamese people, and thus assisted in the accomplishment of the overall mission.
3. Civic action projects that were undertaken, supervised, or aided by Corps Artillery units, either alone or with other US units, included the following:
  - a. A rehabilitation program of 350 former Viet Cong at the Quang Tri National Prison was organized by the 8th Battalion, 4th Artillery. Scrap lumber was also donated for the construction of furniture.
  - b. "Project Phung" was undertaken by 1st Battalion, 44th Artillery, to fit an eight year old girl and her grandmother with artificial legs. The patients were evacuated to the German hospital ship Helgoland, where they were fitted with the artificial limbs. They were returned to their homes in November 1968.
  - c. The 6th Battalion, 33d Artillery, has been aiding the Nuoc Ngot Orphanage for over ten months. The unit has contributed food, supplies, and medical personnel to help the children of the orphanage.
  - d. The village of Cam Lo in Quang Tri Province has received school kits, various educational supplies, construction material, and MEDCAP's from 2d Battalion, 94th Artillery.
  - e. Rodent and pest control, assistance in construction of a 20-25 bed hospital, and MEDCAP visits were carried out by the 1st Battalion, 40th Artillery, in the Dong Ha village area.
  - f. The 1st Battalion, 83d Artillery, provided assistance and supervision in the refurnishing of the Loc Son Buddhist School. After the building was refitted, the unit provided school desks and supplies.
  - g. The 2d Battalion, 138th Artillery, worked with the Bao Sahn Orphanage, in Hue City, providing clothing, medical aid, and other assistance.

h. The 1st Battalion, 44th Artillery, and the 2d ARVN Infantry Regiment combined forces to build a four room school at Dong Ha village.

i. The 8th Battalion, 4th Artillery provided material for, and supervised construction of, school room furnishings in Han Tranh.

**CONFIDENTIAL**

UNCLASSIFIED

Security Classification

DOCUMENT CONTROL DATA - R & D		
<i>(Security classification of title, body of abstract and indexing annotation must be entered when the overall report is classified)</i>		
1. ORIGINATING ACTIVITY (Corporate author)		2a. REPORT SECURITY CLASSIFICATION
HQ, OACSFOR, DA, Washington, D.C. 20310		CONFIDENTIAL
		2b. GROUP
		3
3. REPORT TITLE		
Senior Officer Debriefing Report: BG Allan G. Pixton		
4. DESCRIPTIVE NOTES (Type of report and inclusive dates)		
Senior Officer Debriefing Report, 2 September 1968 through 20 November 1969.		
5. AUTHOR(S) (First name, middle initial, last name)		
BG Allan G. Pixton		
6. REPORT DATE	7a. TOTAL NO. OF PAGES	7b. NO. OF REFS
19 November 1969	29	
8a. CONTRACT OR GRANT NO.	8b. ORIGINATOR'S REPORT NUMBER(S)	
	69BC52	
a. PROJECT NO.	8c. OTHER REPORT NO(S) (Any other numbers that may be assigned this report)	
N/A		
c.		
d.		
10. DISTRIBUTION STATEMENT		
11. SUPPLEMENTARY NOTES	12. SPONSORING MILITARY ACTIVITY	
N/A	OACSFOR, DA, Washington, D.C. 20310	
13. ABSTRACT		

**CONFIDENTIAL**