

UNCLASSIFIED

AD NUMBER

AD510904

CLASSIFICATION CHANGES

TO: unclassified

FROM: confidential

LIMITATION CHANGES

TO:

Approved for public release, distribution unlimited

FROM:

Distribution authorized to U.S. Gov't. agencies only; Administrative/Operational Use; Apr 1970. Other requests shall be referred to Director, Naval Research Laboratory, Washington, DC 20390.

AUTHORITY

NRL ltr, 22 Aug 2002; NRL ltr, 22 Aug 2002

THIS PAGE IS UNCLASSIFIED

L

CONFIDENTIAL

NRL Memorandum Report 2150

AD 510904

**Simulation Facility Using Sensor Imagery
for Tactical Problem Investigations
Summary Report
[Unclassified Title]**

B. KREMER, G. HERMANN, J. PAVCO, AND J. RYON

*Airborne Radar Branch
Radar Division*

DOWNGRADED AT 12 YEAR
INTERVALS; NOT AUTOMATICALLY
DECLASSIFIED. DOD DIR 5200.10

April 1, 1970

This material contains information affecting the national defense of the United States within the meaning of the Espionage Laws (Title 18, U.S.C., sections 793 and 794), the transmission or revelation of which in any manner to an unauthorized person is prohibited by law.



SEP 11 1970

NAVAL RESEARCH LABORATORY
Washington, D.C.

CONFIDENTIAL

Downgraded at 12 year intervals:
Not automatically declassified.

In addition to security requirements which apply to this document and must be met, each transmittal outside the agencies of the U.S. Government must have prior approval of the Director, Naval Research Laboratory, Washington, D.C. 20390.

CONFIDENTIAL

SECURITY

This document contains information affecting the national defense of the United States within the meaning of the Espionage Laws, Title 18, U.S.C., Sections 793 and 794. The transmission or revelation of its contents in any manner to an unauthorized person is prohibited by law.

CONFIDENTIAL

CONFIDENTIAL

MEMORANDUM

Subject: Simulation Facility Using Sensor Imagery For Tactical Problem
Investigations - Summary Report

Background.

(U) The NRL has been involved in tactical and systems analyses directed toward the development of the design requirements for future Navy airborne weapon control systems for all-weather delivery of a stand-off, air-to-surface missile. During the conduct of these analyses it became apparent that there is a need for an in-house simulation facility to permit investigations of problems associated with real time target detection, identification, and designation. This report summarizes the development of this in-house facility. A point of contact at NRL for details on the simulation facility is John C. Ryon (Telephone 202-767-3610; IDS 197-3610).

Findings.

(U) The design and fabrication of the facility is nearing completion and it should be available for simulation efforts in June 1970.

R&D Implications.

(U) The in-house simulation facility will permit, directly under the Navy's control, detailed investigations of the tactical problems associated with:

1. Weapon control of stand-off air-to-surface missiles.
2. Real-time reconnaissance.
3. Trail/road interdiction (TRIM).

System design parameters and tactics for systems employment will be developed from these investigations.

Recommended Action.

(U) The "first phase" simulation facility described in this report will be used in investigations of the problems of using high-resolution radar imagery in

CONFIDENTIAL

CONFIDENTIAL

real-time reconnaissance and weapon control systems. It is recommended that the facility be expanded to include the growth items described in this report. This will permit investigations of methods to present multi-sensor imagery; the possible advantages of color displays and different formats for displaying the imagery.

John C. Ryon
John C. Ryon, Consultant
Airborne Radar Branch
Radar Division

CONFIDENTIAL

TABLE OF CONTENTS (U)

Abstract	v
Problem Status	v
Authorization	v
I. Introduction	1
II. Purpose of The Simulator	1
A. Typical Mission For MMR	1
B. Typical Mission For TRIM	3
C. Typical Mission For Real Time Reconnaissance	4
III. General Description of the Simulation Facility	4
IV. Typical Problem Simulation	5
A. Preparation of The Imagery	5
B. Operator Selection, Briefing and Training	7
V. Simulator Sub-System Description	8
A. Room Layout	8
B. Light Table Description	8
C. Control Circuits	9
VI. Growth Potential	12
VII. Plans For Use of the Simulation Facility	12
VIII. Status	13

CONFIDENTIAL

CONFIDENTIAL

TABLE OF CONTENTS (Con't)

References	14
Acknowledgments	15
Distribution List	16

CONFIDENTIAL

CONFIDENTIAL

ABSTRACT (U)

This report describes the development effort on an in-house simulation facility which uses sensor imagery for tactical problem investigations. Examples of the planned role of the simulation facility in the design and development of Navy air-to-surface weapon systems are given. An example of the operational problem which will be investigated using the simulation facility is described. The plans for growth of the facility to permit simulation of additional Navy tactical problems are outlined.

PROBLEM STATUS (U)

This is a summary report on the development of the NRL simulation facility. The report covers the first-phase effort on this facility. Separate reports covering details of the sub-elements of the facility are in preparation. Work on the overall problem is continuing.

AUTHORIZATION

NRL Problem DOI-03

A 36-533/652-1/W11-180-00

A 36-533/652-1/F17-343-604

CONFIDENTIAL

CONFIDENTIAL

SIMULATION FACILITY USING SENSOR IMAGERY
FOR TACTICAL PROBLEM INVESTIGATIONS
SUMMARY REPORT

I. INTRODUCTION

(U) The Naval Research Laboratory (NRL) has been involved in tactical and systems analyses directed toward the development of the design requirements for future Navy airborne multi-mission weapon control systems, Refs. 1-2. In particular, detailed analyses of the weapon control system requirements to allow an all-weather delivery of a stand-off, air-to-surface missile have been conducted. During the conduct of these analyses it became apparent that there is a need for an in-house simulation facility to permit investigations of problems associated with target detection, identification and designation using imagery collected by the sensors planned for the multi-mission systems. This report summarizes the development of this in-house simulation facility at the NRL. Detailed reports on sub-elements of the overall facility will be issued separately.

II. PURPOSE OF THE SIMULATOR

(U) Three Navy missions will be used as examples to illustrate the purpose of and reason for the in-house simulation facility. The first mission is the all-weather, airborne, stand-off weapon delivery mission proposed for the Navy's multi-mission radar (MMR) system. The second mission is the use of multi-sensors for target detection and designation in the Trails/Roads Interdiction Multi-Sensor (TRIM) aircraft. The third mission is the use of a very high resolution radar in a real-time reconnaissance system.

A. Typical Mission For MMR

(C) Figure 1 is a pictorial representation of the air-to-surface weapon delivery tactics proposed for the MMR system. In Phase I of the mission, a low-level run-in is made to avoid enemy early-warning and defense systems. During this phase, navigation up dating will be accomplished with such sensors as forward looking-IR (FLIR) and low-light-level television (LLLTV). Important questions concerning this phase of the mission, which may be answered through the use of simulation techniques, include:

- a. How well can the operator detect targets and check-points in real time with these sensors?
- b. How well can the operator designate these targets and check-points to accomplish a navigational up-dating?
- c. How well can the operator relate the targets detected in Phase I to the target detection requirements for Phase II?

(C) In Phase II of this mission, the multi-mission aircraft "pops-up" to altitude for stand-off target detection. The stand-off range should be

CONFIDENTIAL

consistent with weapon launch beyond the enemy's offensive capability. This phase of the mission terminates with target designation and initiation of the weapon delivery phase. As shown on Fig. 1, the primary sensor for target detection and designation is a high-resolution radar. While much is known about the use of side-looking, high-resolution radar in a non-real-time application, little is known about the capability of an operator to use squinted, high-resolution radar imagery in a real-time attack situation. Important questions concerning this phase of the mission, which may be answered through the use of simulation techniques, include:

- a. How well can an operator detect a target in real-time using squinted high-resolution radar imagery of a quality consistent with the mechanization limitations in an attack aircraft?
- b. What time is required for detection?
- c. With what accuracy can the operator designate a target using this real-time imagery?
- d. What time is required for designation?
- e. What kinds of reconnaissance information should be used in pre-flight briefing of the operator to insure a high probability of target detection and designation?
- f. In what format should the high-resolution radar imagery be presented to the operator?
- g. What auxiliary information (charts, photos, etc.,) is needed by the operator during this phase?

(C) Phase III consists of weapon delivery and control. As illustrated on Fig. 1, this phase may consist of weapon delivery at stand-off range or a short-range weapon delivery during a low-level run-in. Among the important questions concerning this phase of the mission, which may be answered through the use of simulation techniques, are:

- a. How do the target detection and designation times, which are determined through simulation, affect the design requirements of the weapon control system for various weapon mid-course and terminal guidance combinations?
- b. How do the designation accuracies, which are determined from simulation, affect the design requirements of the weapon control system?

CONFIDENTIAL

CONFIDENTIAL

c. How do these times and accuracies affect the design requirements of the terminal guidance system?

d. How does the offset course for the attack aircraft (required for squinted radar operation) affect the conversion problems associated with short-range weapon delivery?

e. How well can the operator use the forward, beam-sharpened mode of the MMR for conversion to weapon delivery?

(C) The NRL has conducted simulations at Westinghouse Aerospace Division in an attempt to obtain gross answers to some of these questions, Ref. 3. Figures 2-6 give examples of some of the results when imagery from the Westinghouse APQ-97 radar (a real aperture, non-real-time, reconnaissance radar) were used in these simulations. These results should not be interpreted as being typical of those to be obtained with the MMR which will be a real-time, synthetic aperture radar. They are included only to illustrate the types of answers which can be provided by simulation techniques and to stress the importance of using imagery of the proper quality. Figure 2 illustrates the probability of check-point acquisition using two different formats for presenting the imagery to the operator, "passing scene" and "sequential snapshot". If the same trends continue when simulations are conducted with MMR imagery, system performance will be relatively insensitive to the choice of formats. The final decision on the format to be used could be based solely on mechanization considerations. Figure 3 illustrates the probability of target area recognition as a function of time, with resolution of the radar and the width of the image (swath) presented to the operator as parameters. As can be seen, system performance was insensitive to these parameters over the range of values investigated in the simulation. The probability of target acquisition for several target types is shown on Fig. 4. These results demonstrate that for the particular imagery which was used, acquisition of some classes of targets will be difficult. The influence on probability of target acquisition of the size of the operator's display is shown on Fig. 5. Within the limits of the investigation, target acquisition performance is insensitive to display size. On Fig. 6, the percentage of targets designated as a function of error for two radar resolutions is shown. For the targets investigated the results for 50-foot resolution were significantly better than for 100-foot resolution. These examples illustrate typical simulation results.

B. Typical Mission for TRIM

(C) The TRIM/A-6C aircraft recently supplanted the TRIM/P-3 aircraft in Southeast Asia for trail interdiction. Figure 7 shows a block diagram of the sensors and weapon control sub-systems on this aircraft. The sensors used for target detection and designation are LLLTV, FLIR, and radar. Sensor modifications are planned as improved sensors become available. The TRIM/P-3 was developed

CONFIDENTIAL

CONFIDENTIAL

on an emergency basis and did not have the benefit of detailed investigations of operator performance. Detailed simulations of the capabilities of the operator when using the sensors in the A-6 aircraft are needed. Many of the types of problems discussed for the MMR apply equally well here. Among the questions that may be answered with simulations are:

- a. How well can an operator detect a target with the available sensors?
- b. What time is required for detection?
- c. What time is required for and what is the accuracy of target designations?
- d. What format should be used in presenting the imagery?
- e. Should the multi-sensor imagery be presented on parallel displays or overlaid on one display?
- f. Will the use of color displays improve operator performance?

C. Typical Mission For Real-Time Reconnaissance.

(C) The Navy is investigating the tactical advantages associated with the use of a real-time reconnaissance system. Figure 8 illustrates one proposed approach which uses a side-looking, high-resolution radar. The reconnaissance data are collected at stand-off ranges and analyzed in real-time in the reconnaissance aircraft. These data are transmitted back to the carrier for detailed intelligence analyses and for pre-strike planning. In addition, targets are designated in the reconnaissance aircraft in real-time attacks. Among the important questions which can be answered with simulations are:

- a. What targets can an operator detect using real-time, high-resolution radar imagery of a quality consistent with the reconnaissance environment?
- b. What time is required for detections?
- c. How accurately can the operator designate targets?
- d. What time is required for designation?
- e. Is the attack aircraft weapon delivery performance improved as a result of having target designation information from the reconnaissance aircraft?

III. GENERAL DESCRIPTION OF THE SIMULATION FACILITY

(U) A block diagram of the simulation facility is shown on Fig. 9. Pertinent elements of the facility are:

- a. A Light Table and associated Motor Drive.

CONFIDENTIAL

CONFIDENTIAL

b. A Vidicon television camera (Maryland Telecommunications VC23), Zoom Lens, and Positioning Servo for positioning the camera over the Light Table.

c. Two Monitor Oscilloscopes (CONRAC-CQF14) for presenting the output of the Vidicon to the Operator and to the Test Controller.

d. The Operator

e. A Joystick which controls the Crosshairs Generator, Positioning Servo and Zoom Control.

(U) With the exception of commercial items included in the above list the design and fabrication of the simulator facility was accomplished in-house. Design specifications for the overall simulation facility are given in Ref. 4.

(U) A unique feature of the simulation facility is the method for viewing the imagery with the Vidicon. The filmed imagery is viewed by the Vidicon which is positioned above a Light Table. The Light Table, which is shown in the artist's sketch of Fig. 10, is being fabricated by the Richards Corporation. The imagery is placed on the flat surface of the Light Table where it is back-lighted by a uniform light source. The imagery does not move during operation. Instead, the Vidicon is positioned by the Position Servo and Motor Drive in a manner which simulates aircraft motion.

IV. TYPICAL PROBLEM SIMULATION

(U) Before describing the operation of the sub-elements of the simulator a typical simulation problem, and the preparatory steps for this simulation, will be described. The simulation of target detection and designation with the MMR is used as an example.

A. Preparation of the Imagery.

(U) Figure IIA illustrates a series of film strips, each 50" long x 5" wide. Each strip represents high-resolution radar imagery of an area 50 nm long x 5 nm wide. Although the individual strips are joined together in a continuous strip, only a single 50" strip would appear on the surface of the Light Table at any one time.

(C) On Fig. IIB, typical targets of interest such as airfields, bridges, docks, factories, dams, and railroad marshalling yards, have been indicated by numbered circles. The targets will be selected such that there will be at least 20 seconds run-in time prior to the appearance of a target on the display. This permits simulation of Phase I in the MMR example discussed earlier. X_0 is the distance between the start of the run and the position of the first target, while X_1, X_2, \dots, X_n represent the spacings between targets. These spacings will correspond to a minimum of 4 nm which is equal to the radar field-of-view (FOV). Thus, on a given run against one of the targets, the operator will not

CONFIDENTIAL

CONFIDENTIAL

view targets to be used in following runs (a run is terminated when the target leaves the FOV).

(U) On Fig. IIC, target positions are coded in the circles where, for example, 1A, 2A 1B, 2B refer to target 1 on film strip A, and target 2 on film strip B respectively. Position 0, coded on the edge of the film strip, is the initial position of the vidicon. Additional coding on the edge of the film strip, I', II', III', mark the start of run for Target 1A, start of run for target 2A, and start of run for 3A, respectively. Target 1A enters the FOV of the display at IV and leaves the FOV at V, target 2B enters the FOV of display at VI and leaves the FOV at VII, etc. Each of the coded positions represents a point of interest during a simulation and the time of their occurrence is recorded. During a run, the time when the operator attempts a target detection, will be recorded.

Typical variables during a simulation will include:

- a. Attack aircraft velocity
- b. Target type
- c. Operator
- d. Radar resolution

Typical fixed parameters will include:

- a. Simulated altitude
- b. Radar FOV
- c. Display brightness and contrast

Typical simulation outputs will include:

- a. Target detection time
- b. Target designation time
- c. Target miss distance
- d. Probability of target designation

CONFIDENTIAL

CONFIDENTIAL

B. Operator Selection, Briefing and Training

(U) Experience has shown that engineering personnel may be used successfully as operators. In the NRL simulation effort a mixture of engineering and operational personnel will be employed. Ideally, the combination of number of operators and number of targets in any one simulation efforts should be such that the confidence level in the statistical results is high (such as 90%). In actual practice there are necessary compromises among the number of operators available, the time the operators are available, and the quantity of imagery.

(U) In preparation for a simulation, a group briefing will introduce the operators to the simulation, its objectives, operational procedures, and the types of results desired. In individual briefings, a detailed description of the simulator and its operation will be given, the controls and the display will be demonstrated, and practice runs will be made.

(U) During the individual operator training cycle, each operator will practice against a variety of targets of varying difficulty during which his performance will be evaluated. If his performance level is sufficiently below the "norm" established by a learning curve, he will not participate in the simulation.

(U) A typical operation (simulation) would proceed as follows:

After the operator has been briefed, the test controller causes the vidicon to travel along the length of the film strip at a rate corresponding to the simulated aircraft speed. This represents the search mode of operation. Video is presented on the operator's display when the vidicon reaches the starting point for the run. The time that the target first enters the FOV is recorded. This represents the first opportunity for target detection. When the operator recognizes the target, he places electronically-generated crosshairs over the target by control of the joystick, and pushes the "freeze" button on the joystick stopping the movement of the vidicon. The time of this action is recorded as the time required for target detection. The lens on the vidicon automatically zooms to simulate the zoom mode of the MMR. The operator then repositions the crosshairs over the target, if necessary, and presses the "designate" button, also on the joystick, which removes the video from his display. The time of this action is recorded as the time required for target designation. The test controller then measures the X/Y position of the crosshairs relative to the target position as a measure of designation accuracy.

If, prior to pressing the designate button, the operator feels that he has selected the wrong target, he can press the freeze button a second time to initiate return to the search mode. If this occurs, the vidicon lens returns automatically to the un-zoomed position and the vidicon assumes its travel along the film at a rate corresponding to the simulated aircraft speed.

CONFIDENTIAL

CONFIDENTIAL

The operator may select a second target and go through the target detection and designation steps again as described above. If the operator does not designate the target prior to the time it leaves the FOV, the test controller stops the run.

V. SIMULATOR SUB-SYSTEM DESCRIPTION

A. Room Layout.

(U) Figure 12 shows a layout of the equipment in the simulator room. The room is divided into two areas by a heavy curtain. One area contains an aircraft Cockpit mock-up with the operator's Monitor and controls.

(U) The other area of the room, the normal location of the test controller, contains the Equipment Rack and the Light Table. The Equipment Rack houses timing and interface circuitry and the test controller's Monitor. This area also contains working space for briefing and imagery preparation.

B. Light Table Description.

(U) The Light Table, shown in Fig. 10, serves to:

- a. Illuminate the imagery to be viewed by the zoom lens of the vidicon.
- b. Support and position the vidicon during two modes of operation as follows:

1. The carriage which carries the vidicon is driven along the film at a rate to simulate the aircraft velocity in the search mode of the simulation.

2. When the operator pushes the freeze button, the vidicon is disengaged from the carriage and the positioning servo carries the vidicon to a position controlled by the operator's joystick. This corresponds to the target designation mode of the simulation. If the operator feels he has selected the wrong target and returns to the first mode by pushing the freeze button a second time, the positioning servo returns the vidicon to the film center and drives the vidicon until it catches up to the carriage which has continued at the simulated aircraft speed during the unsuccessful attempt to designate.

- c. Provide a group of three photo-cells which are used to detect the coded points of interest on the film which were described in Section IV A.

CONFIDENTIAL

CONFIDENTIAL

C. Control Circuits

(U) Figure 13 is a drawing of the Test Controller's Position. There are two basic equipments located at this position, the Monitor Oscilloscope and the Timing and Control Unit. The Timing and Control Unit provides controls for the light table and for the vidicon. Figure 14 shows the front panel of the Timing and Control Unit. The Nixie tubes (digital displays) on the left of the panel indicate the times of pertinent events during a simulation. From top to bottom, these displays indicate:

- a. The total elapsed time.
- b. The time when a target first enters the FOV.
- c. The time of target detection.
- d. The time of target designation.
- e. The time for the second attempt to detect a target.
- f. The time for the second attempt to designate the target.

Times e) and f) occur only if the operator has previously thought he had detected the target and then decided that it was the wrong target.

(U) In the center of the panel there are three groups of displays and controls. The top group consists of a Nixie tube display of the number of coding marks on the film which have occurred on any one run (Elapsed Film Markers) and two thumbwheel switches. These switches are used to set in the number of the film code mark which will start the run (Starting Mark) and the number of the code mark for the time that the target comes into the FOV (Field of View Mark). The second group consists of controls to reset the light table for a new run (Light Table Reset), a switch for removing the video from the operator's display (Blank/Unblank), a start-stop switch for the vidicon drive (Clocknut), a pushbutton switch to reset the Nixie displays (Digital Reset), a power on-off switch and a light to indicate that the target is out of the FOV. The Manual controls in the third group permit manual control of the light table and vidicon during imagery preparation.

(U) The Event Markers in the upper right of the panel are lights which indicate the status of any one simulation run. These lights indicate the start of a run, that a run is an operation, and when the system is in the freeze and designate modes. The controls on the lower right of the panel are used by the test controller to set up the zoom lens. A thumb-wheel switch is used to

CONFIDENTIAL

set the period of time that the operator's display will be blanked when the vidicon lens is zoomed. Another switch may be used to over-ride this blanking.

(U) Figure 15 is an overall block diagram of the simulator. The Light Table is shown at the lower left of this diagram. Inputs to the Light Table are commands from the Carriage Drive Generator, automatic and manual zoom commands from the Simulator Control, and X-Y position information from the operator's Joystick. The outputs from the Light Table are TV video and photo-cell coding information.

(U) The Carriage Drive Generator provides a voltage to position the vidicon during the search phase of operation. The frequency of this voltage, which is monitored by a frequency counter, determines the speed that the vidicon is driven along the film and thus, the simulated aircraft speed.

(U) The Camera Control accepts video from the vidicon and sends video and synchronizing signals to the Operator's Monitor and the Test Controller's Monitor. The Crosshairs Generator electronically generates crosshairs whose position on the Operator's Monitor and the Test Controller's Monitor are controlled by the Joystick.

(U) When the freeze button is depressed, the Vidicon goes to a position above the Light Table which corresponds to the position of the crosshairs, and the zoom of the Vidicon lens is started. Pushing this button a second time "un-freezes" the display and returns the zoom lens to its normal position. Another button on the Joystick is used for target designation. The operator will push this button when the system is in the freeze mode and he feels that he has accurately positioned the crosshairs over the target with the Joystick. Pushing this button prevents further movement of the crosshairs and ends that simulation run.

(U) Figure 16 is a simplified block diagram of the simulator control logic. All simulator functions are controlled by the position of a logic 1 in the Shift Register. Resetting the system puts this logic 1 in position 1 of the Shift Register. Using Figs. 15 and 16, a hypothetical simulation run will be described. The Carriage Drive Generator is set for the proper aircraft speed. The Starting Mark and Field of View Mark counters are set. The Zoom Time is set and the Shift Register is reset. The operator's display video is blanked. At this time, the Ready and Reset lights are the only lights that are on at the Test Controller's Control Unit. The Carriage Drive Generator switch is thrown to the "on" position, causing the Vidicon to start

CONFIDENTIAL

travelling along the length of the film. When the number of film code marks reaches the preset value for start, the Reset and Ready lights go off, the Run light comes on, and the Elapsed Time Nixie display starts (R01 on Fig. 15). When the number of coded film marks equals the number that was set in to indicate that the target has entered the FOV, the FOV light comes on and the Target Enters Field of View Nixie display stops to indicate the time from the start of the run until the target enters the FOV (R02 on Fig. 15).

(U) The operator sets the crosshairs over the target and pushes the freeze button. This shifts the logic 1 into position 2 of the Shift Register, the 1st Freeze light comes on, and the Target Area Detection (First Freeze) Nixie display stops to indicate the time from the start of the run until the first freeze (R03 on Fig. 15). The Elapsed Time Nixie display stops, the Zoom-in operation is started, the Carriage Drive Generator is stopped, and the vidicon position is now controlled by the Joystick. While the vidicon lens is zooming, the video is removed from the operator's display. When the Zoom Time counter reaches the pre-set time, the logic in the Shift Register goes to position 3, the 1st Zoom light comes on, the 1st Freeze light goes off, the Elapsed time clock starts, and video is again presented on the operator's display.

(U) At this point, if the operator decides that he has selected the right target, he places the crosshairs over the target and pushes the designate button. This causes the logic 1 to go to position 4 of the Shift Register, the 1st Designate light to come on, and the Target Designate (First Designate) Nixie display stops to indicate the time from the start of the run until first designation (R04). Additionally, the crosshairs position is locked, the video is removed from the operator's display, and the Terminate light comes on.

(U) If, however, the operator decides that he has selected the wrong target, instead of pushing the designate button he pushes the freeze button a second time. This causes the logic 1 to skip position 4 and go to position 5 of the Shift Register. The Elapsed time clock stops, the zoom starts out, the zoom timer starts, video is removed from the operator's display and the vidicon position is now controlled from the Carriage Drive Generator. When the Zoom Time Counter reaches the pre-set value, the logic 1 is shifted to position 6 of the Shift Register, the Carriage Drive and Elapsed time clock start, and the video is displayed to the operator.

(U) When the operator selects another target, the above steps are repeated except that Shift Register positions 7, 8, and 9 are used. Anytime the target goes out of the FOV, the Test Controller can terminate the run. When this happens, the operator's video is removed from his display and the Terminate light comes on.

CONFIDENTIAL

VI. GROWTH POTENTIAL

(C) The simulation facility which has been described in the preceding sections is the result of a first-phase effort. Its design has deliberately allowed for flexibility to incorporate changes to accommodate additional mission simulation problems. Desirable growth items would include:

a. Electronic or automatic, rather than manual, measurement of designation errors. This should improve accuracy and save time.

b. Installation of an F-14 cockpit in place of the F-111 cockpit which was utilized because of its availability. This would add realism to the simulation since future systems, such as the MMR, will be installed in the F-14 aircraft.

c. Another vidicon, zoom lens and light table. This will permit the parallel display of the imagery from two sensors or the simultaneous presentation of the image from two sensors on one display, for the simulation of a multi-sensor aircraft system. The advantages of presenting multi-sensor data on the same display, but in different colors, could also be investigated.

d. The first phase facility was designed for a "passing scene" display. Preliminary NRL studies indicate that an operator performs equally well with either a passing scene or sequential snapshot display. Because the final selection of the display mode has important mechanization implications, the simulation facility should be modified to permit further investigation of this problem.

VII. PLANS FOR USE OF THE SIMULATION FACILITY

(C) The "first Phase" simulation facility along with desirable growth items, has been described in the preceding sections. It is planned that the fabrication and checkout of the facility will be completed in June 1970. The simulations of the problems of using imagery from sensors in the following systems will start shortly thereafter.

A. Air-to-Surface Weapon Control For MMR.

The sources of high resolution radar imagery for this simulation include the APQ-108 radar, Hughes Aircraft Co. flight tests of the MMR, Westinghouse Aerospace flight tests of the FWCS, and Raytheon tests under the RARF program. The effects of target type, briefing material, swath width, display size, side-looking vs squint, and display contrast and brightness on target detection and designation will be investigated. The problems of presenting and using the imagery from multi-sensors (TV, IR, radar) either in

CONFIDENTIAL

CONFIDENTIAL

parallel or overlaid, will be studied. The capability of converting from the high-resolution radar mode to the forward-beam-sharpened mode of operation will be determined.

B. Real-Time Reconnaissance.

Sources of high resolution imagery for this simulation include the APQ-108 radar and an Air Force/Westinghouse radar. This effort will parallel that of item A except it will concentrate on reconnaissance aspects. Parameters to be investigated include target type, available intelligence information, swath width, resolution, display size, display brightness and contrast. Methods of presenting intelligence data (maps, aerial photos, etc.) will be studied. The tactical improvement resulting from being able to give the attack aircraft target coordinate information in real-time will be investigated.

C. TRIM

Simulations will be conducted on the operator's ability to utilize the TRIM multi-sensor imagery (LLTV, FLIR, and radar) in trail and road interdiction. Parallel or simultaneous display of multi-sensor data on black and white displays will be studied. The advantages of multi-color display of TRIM imagery will be investigated.

VIII. STATUS

(U) This report describes the status of the development of an in-house simulation facility at NRL. The design and fabrication of the facility is nearing completion and should be available for simulation efforts in June 1970. Long-term progress toward desired simulations is contingent upon the availability of suitable imagery from flight tests.

(U) The growth items for the facility are important to the development of design requirements for future Navy weapon systems. It does not appear that there are any technical difficulties in acquiring these growth items.

CONFIDENTIAL

CONFIDENTIAL

REFERENCES

1. NRL Memo Report 1399, "Technical Requirements and Cost Effectiveness Study for U. S. Limited War Systems," March 1963 (S)
2. NRL Memo Report 1600, "Technical Requirements and Cost Effectiveness Study for U. S. Limited War Systems, Detailed Analytical Solution," December 1967 (S)
3. NRL Memo Report 1906, "A Study of Operator Performance in the Real Time Detection and Designation of Tactical Targets From High Resolution Radar Data," March 1968 (C)
4. NRL Technical Memorandum 5361-125A, "Specification for Light Table," November 1969 (C)

CONFIDENTIAL

CONFIDENTIAL

ACKNOWLEDGMENT

(U) The development of the simulation facility is a result of the combined efforts of the Tactical Analysis Section, the Display Systems Section, and the Signal Processing Section of the Airborne Radar Branch. Assistance in the preparation of this report was provided by D. Ringwalt. The experience and the background in the tactical problems to be investigated, and the simulation approach are a result of participation in NAVAIR sponsored air-to-surface weapon delivery programs and in developmental programs such as the Future Weapon Control System under development at Westinghouse and the Multi-Mission Radar System under development at Hughes Aircraft Company. Close technical working relationships with NAVAIR and NADC personnel has contributed materially to the simulation development.

(U) The simulation facility development has been sponsored by NAVAIR through the following tasks at the NRL:

1. Air-to-Surface Acquisition and Weapon Control - AIRTASK A-36-533/652-1/W11-180-00, responsible NAVAIR representatives (AIR-5333) W. Bailey, L. Kreitzer, J. Guignon, E. Haskell.
2. Multi-Sensor Concepts - AIRTASK A36-533/652-1/F17-343-604, responsible NAVAIR representatives (AIR-5333) E. Cosgrove, J. Johnson.
3. Display and Data Processing - AIRTASK A36-533/652-1/W11-180-00, responsible NAVAIR representative (AIR-5333) W. Bailey.

It is planned that additional sponsorship in the following areas will be available in FY '71:

- a. Radar for Real-Time Reconnaissance System - NAVAIR responsible representative (AIR-5333) J. Fox.
- b. Project TRIM Multi-Sensor Usage - NAVAIR responsible representatives, (AIR-5333) E. Cosgrove, D. Armbruster.

CONFIDENTIAL

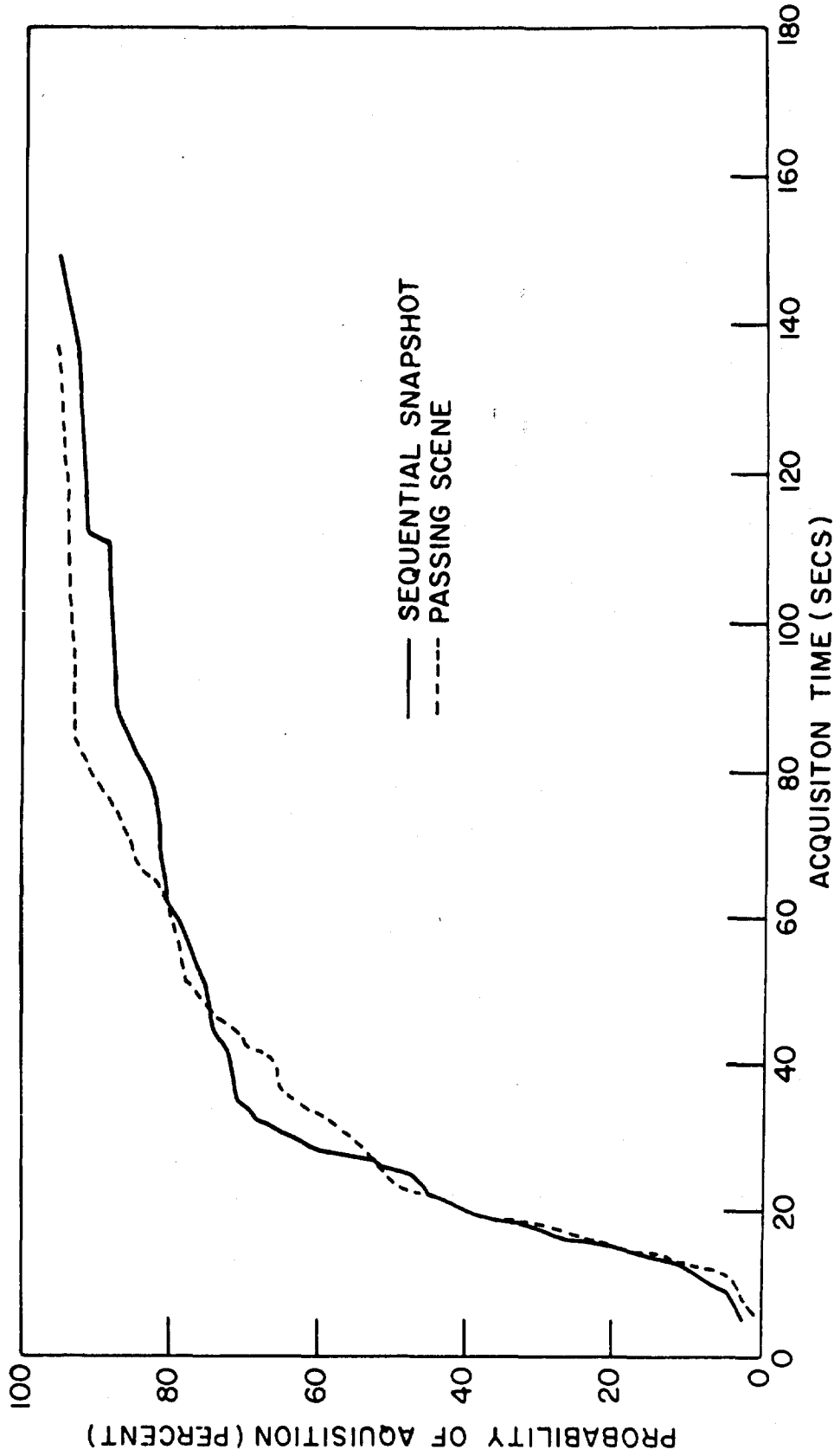

Fig. 2 - Probability of checkpoint acquisition as a function of time for passing scene and sequential snapshot presentation modes (C)

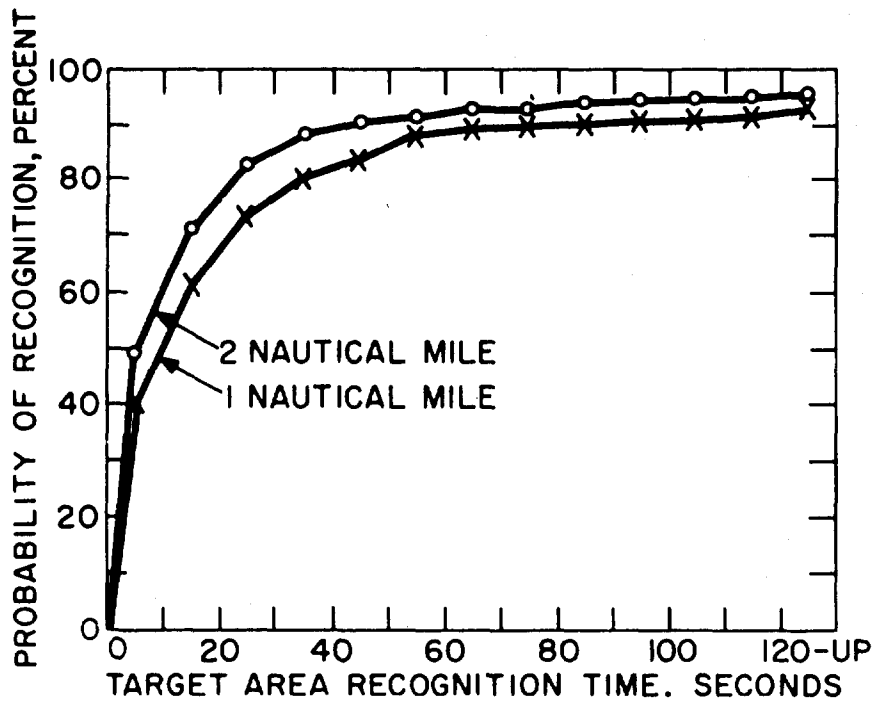
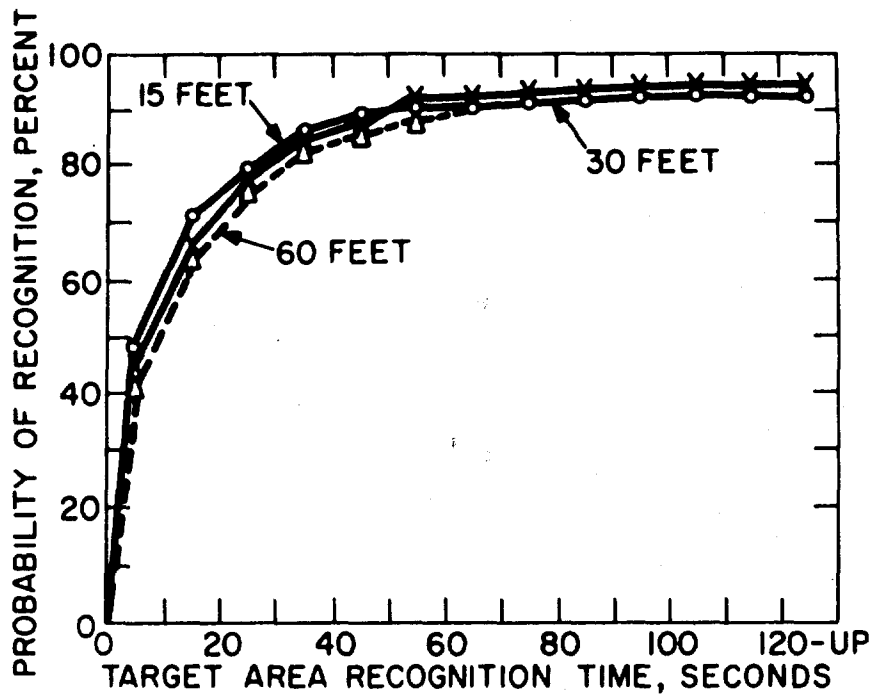
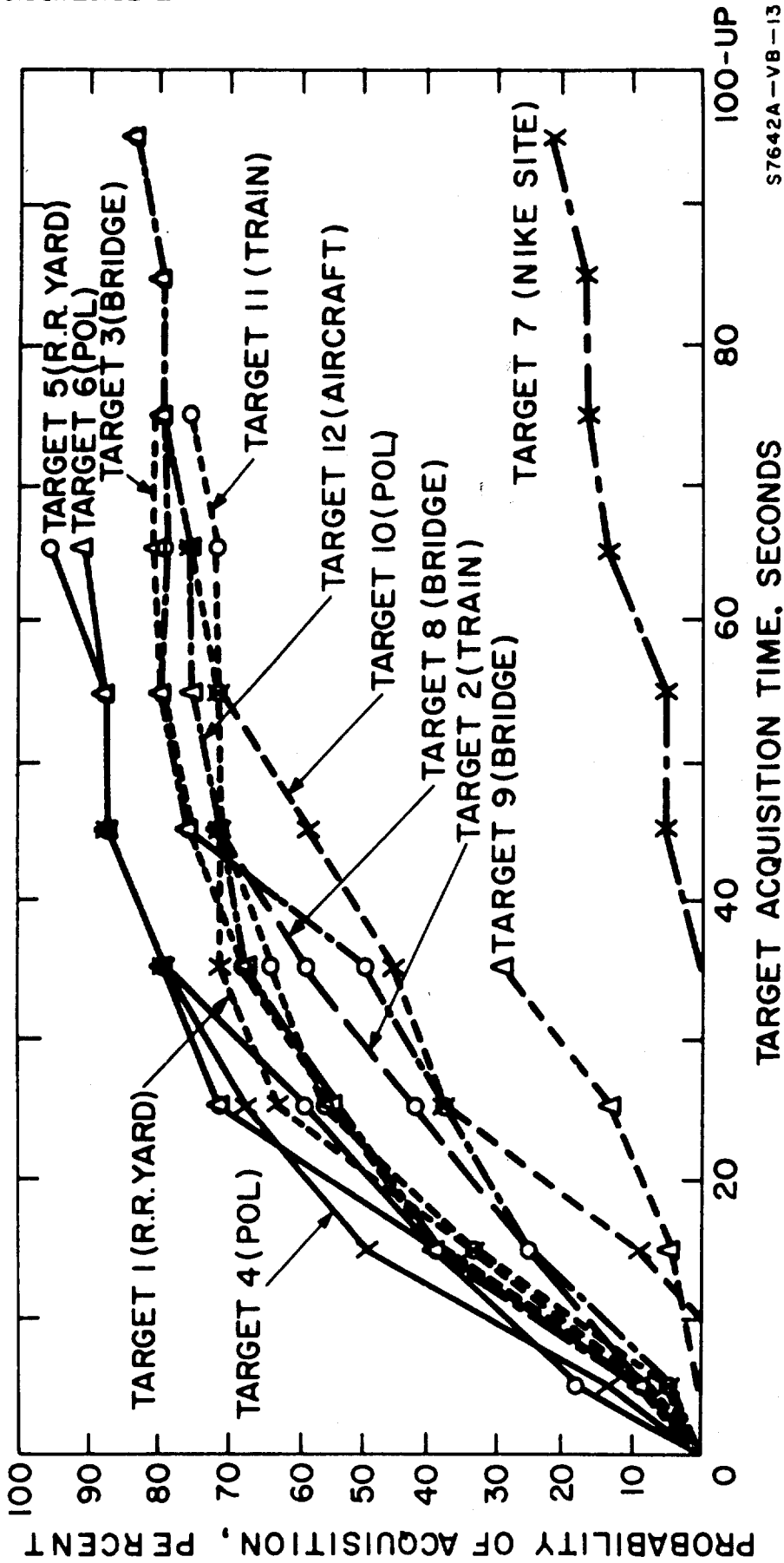
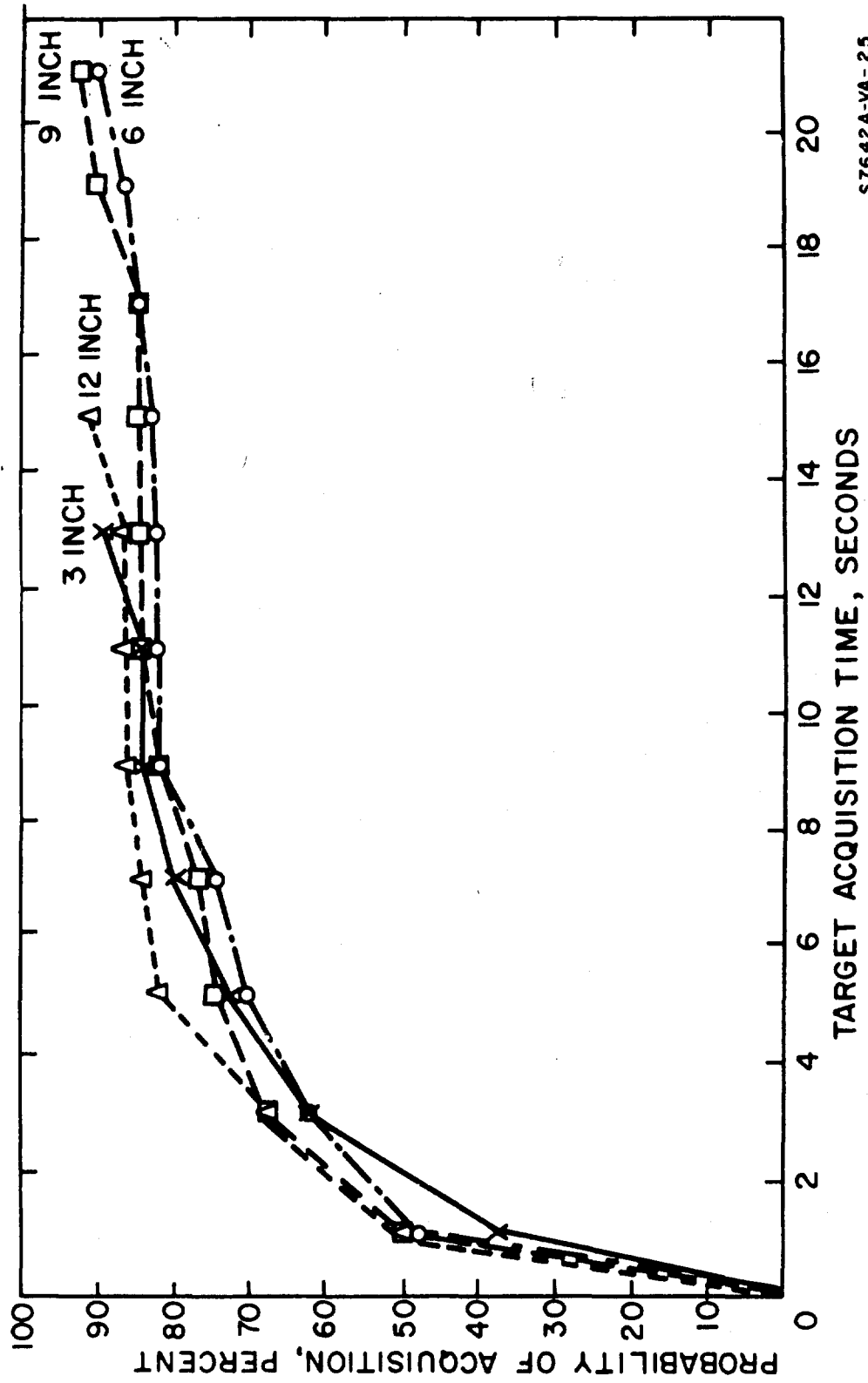

Fig. 3 - Probability of target-area recognition (C)



S7642A-VB-13

Fig. 4 - Probability of target acquisition as a function of time for targets (C)



S7642A-VA-25

Fig. 5 - Probability of target acquisition as a function of time for 3-, 6-, 9-, and 12-inch displays (C)

CONFIDENTIAL

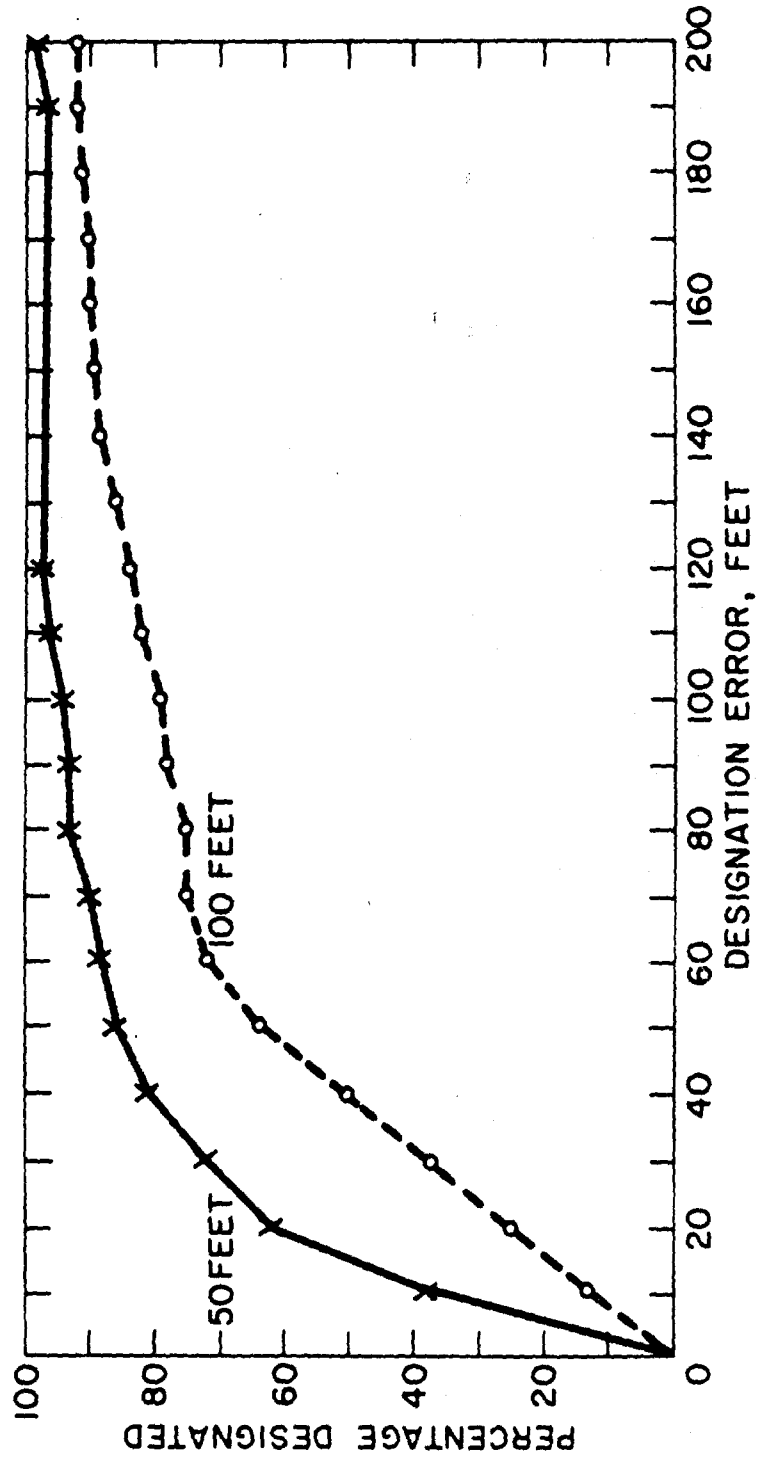

Fig. 6 - Percentage of targets designated as a function of error for 50- and 100-foot resolutions (C)

CONFIDENTIAL

CONFIDENTIAL

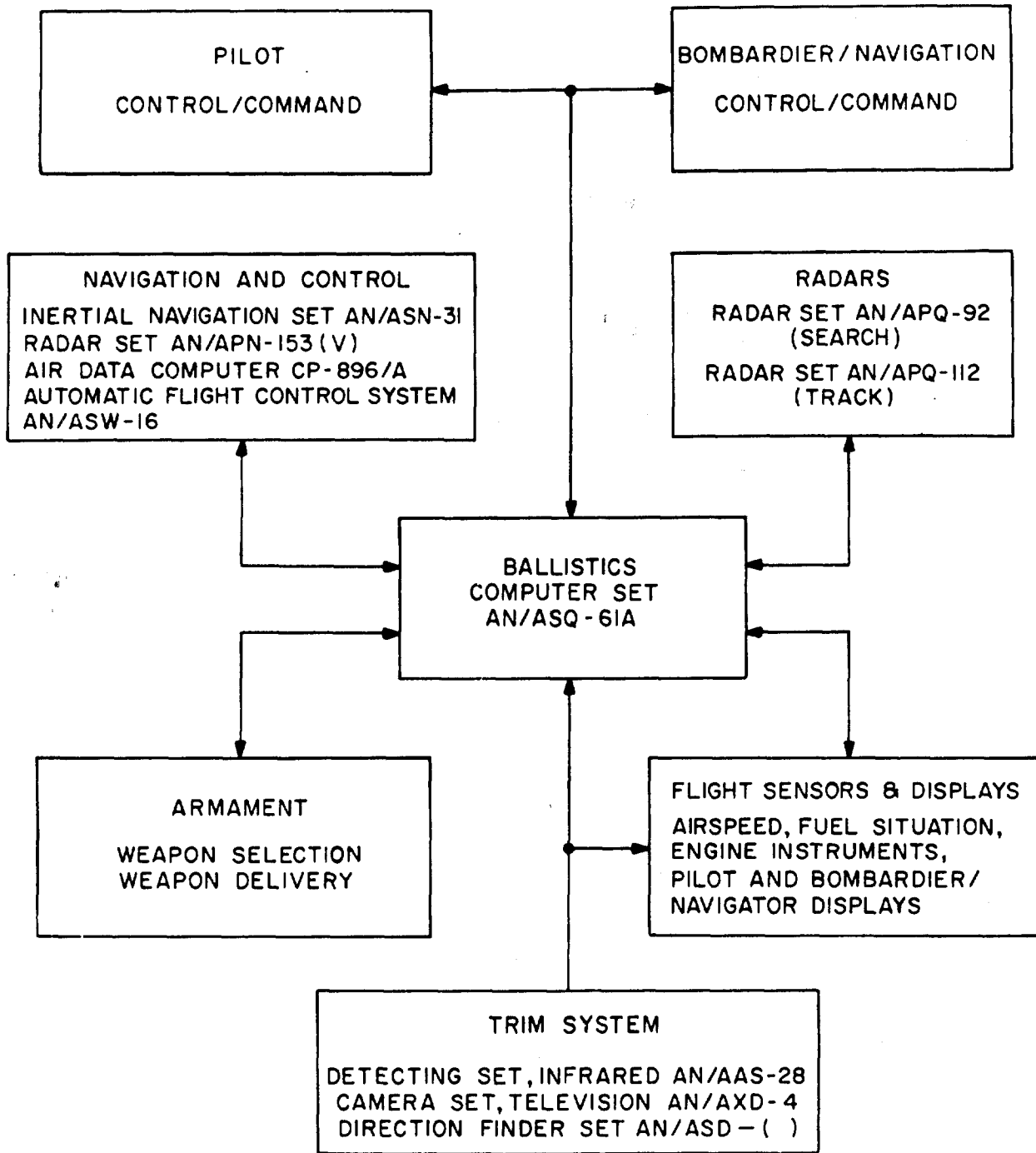

Fig. 7 - TRIM/A-6C block diagram (C)

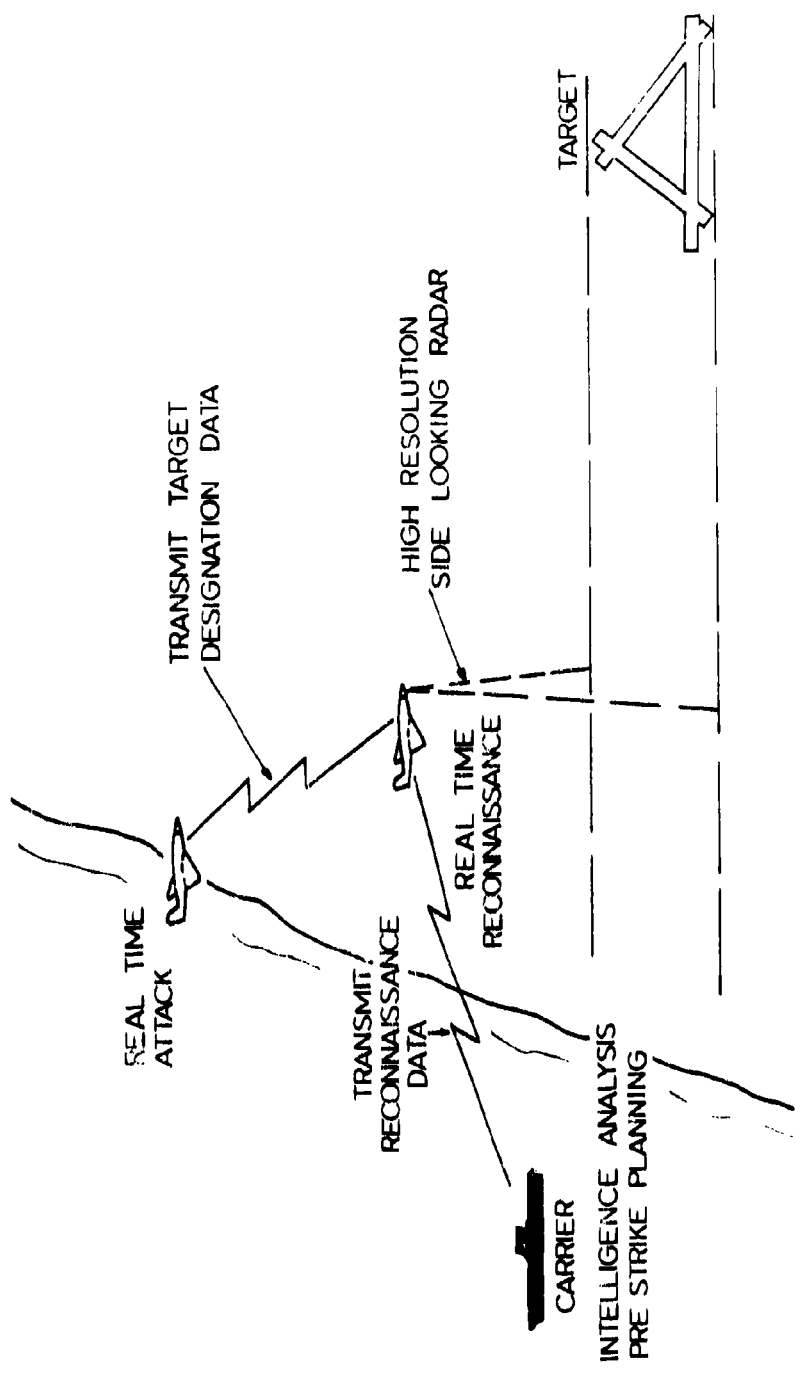

Fig. 8 - Real-time reconnaissance system (C)

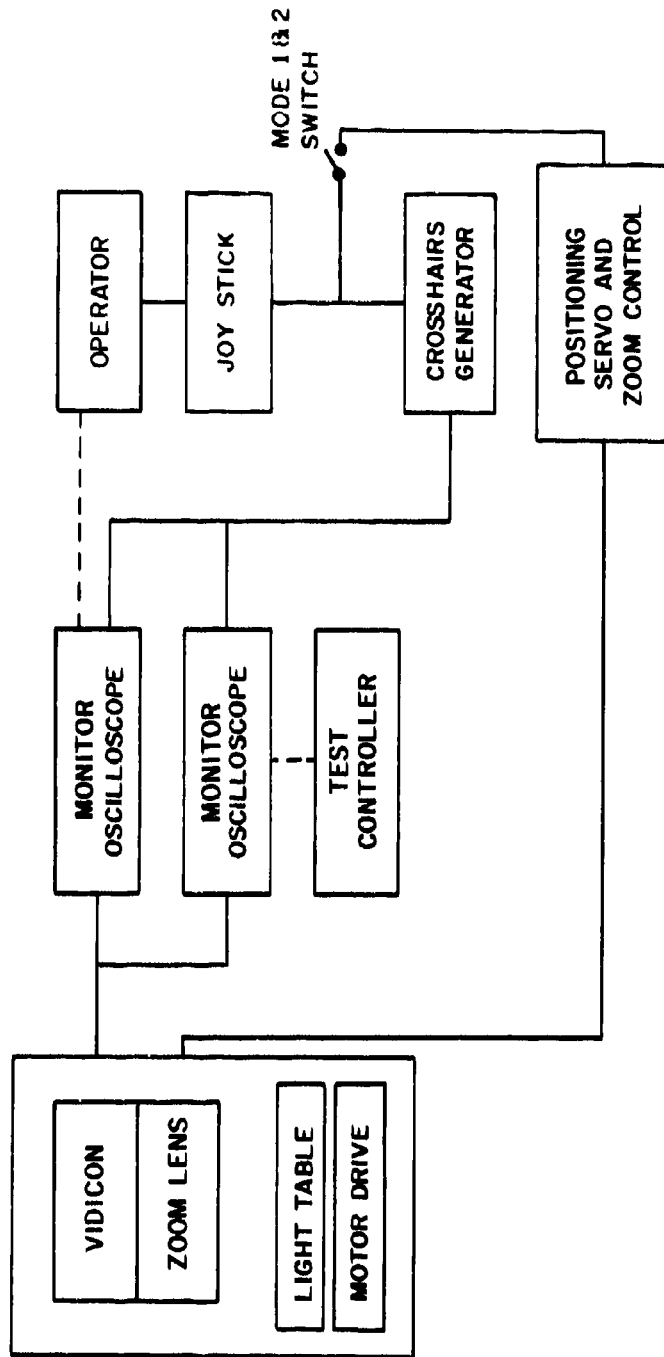

Fig. 9 - Block diagram of simulator (C)

CONFIDENTIAL

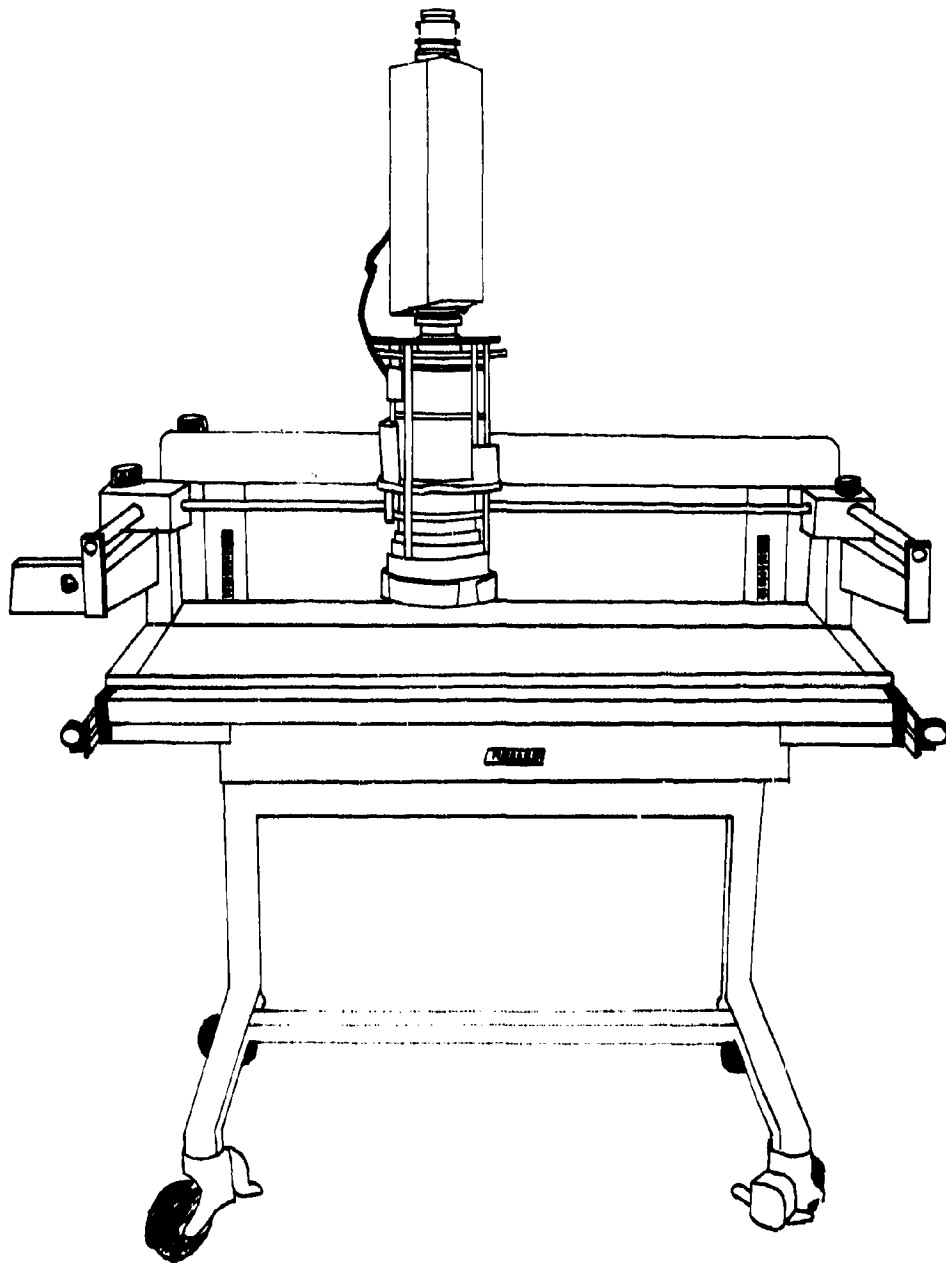

Fig. 10 - Light table (C)

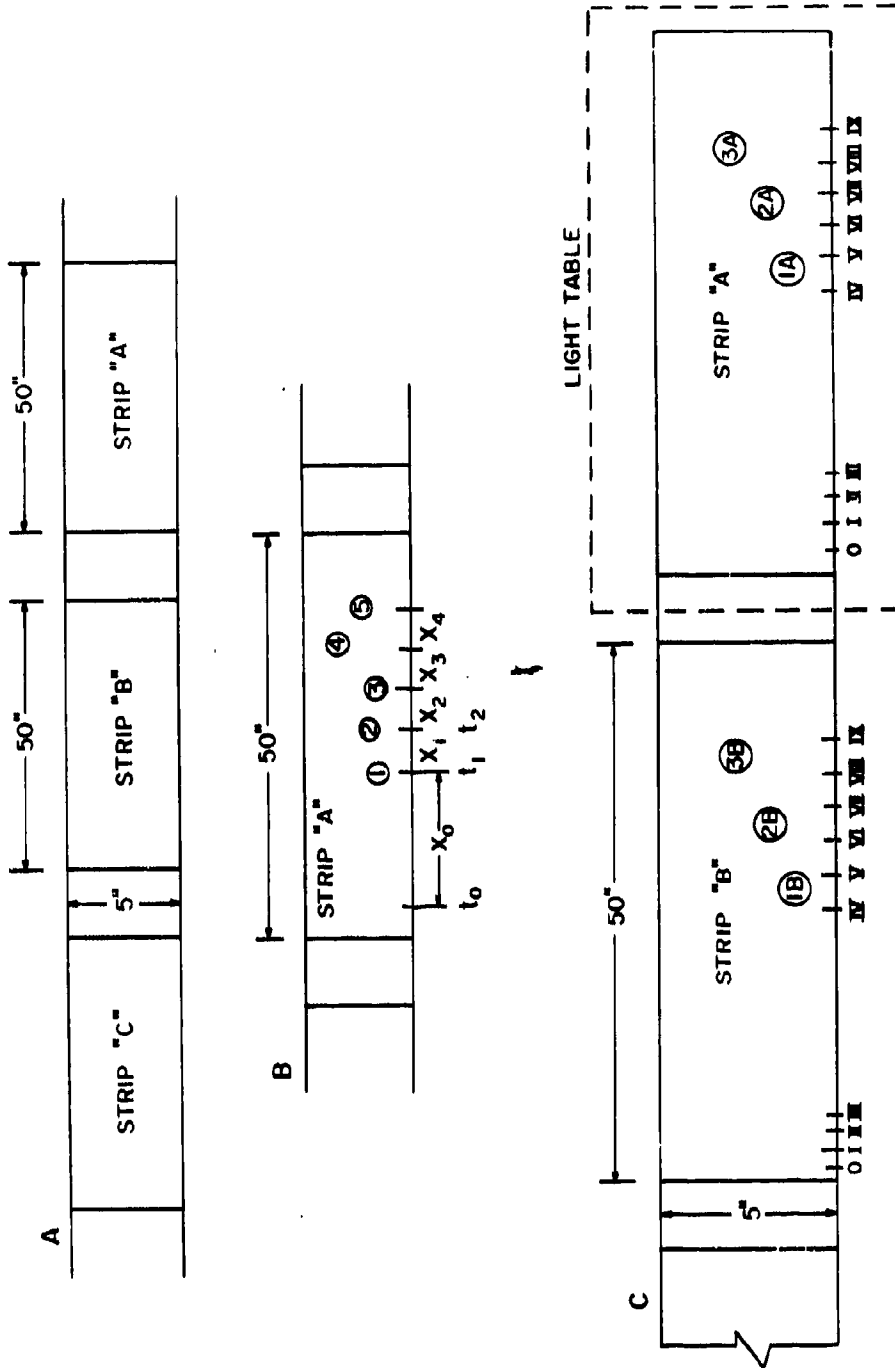

Fig. 11 - Imagery preparation (C)

CONFIDENTIAL

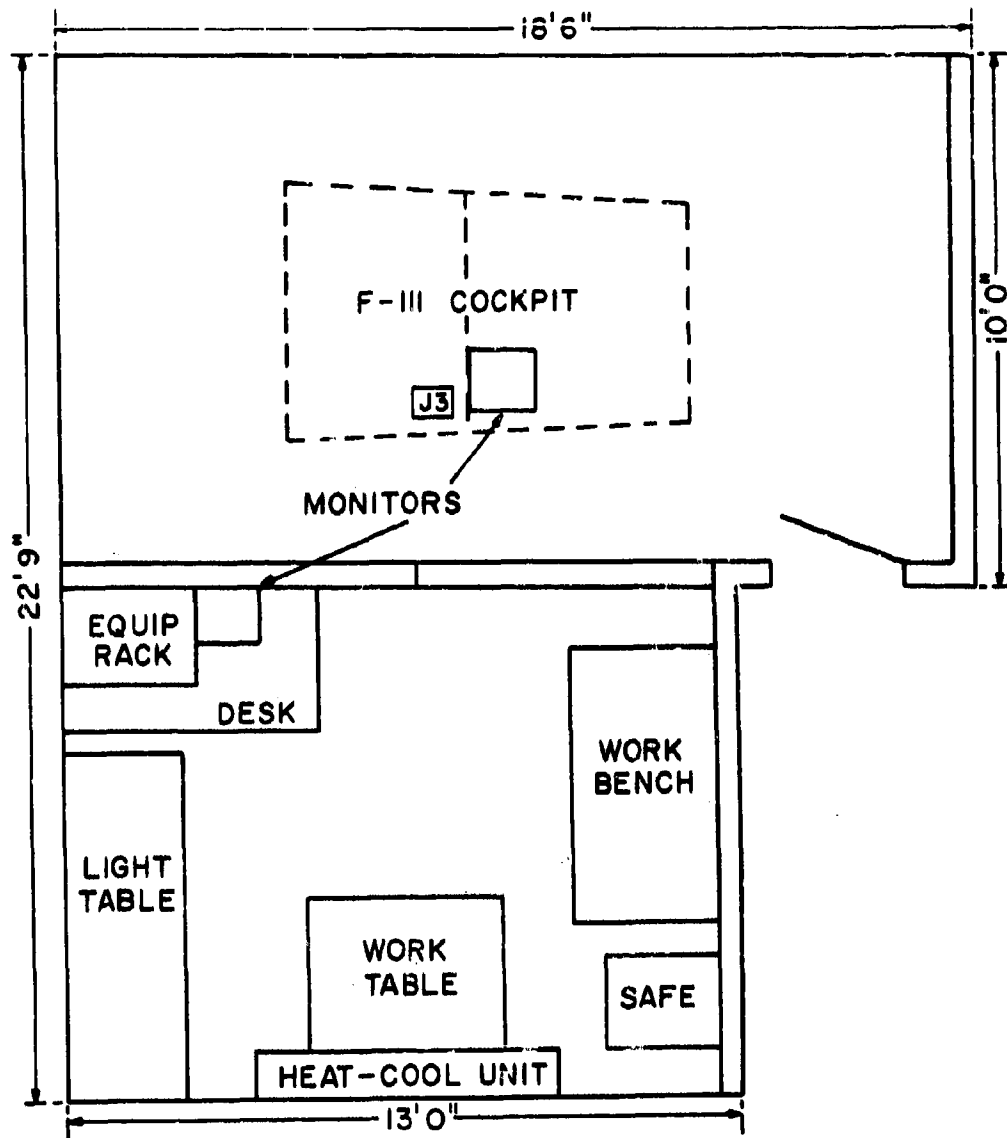

Fig. 12 - Simulator room layout (C)

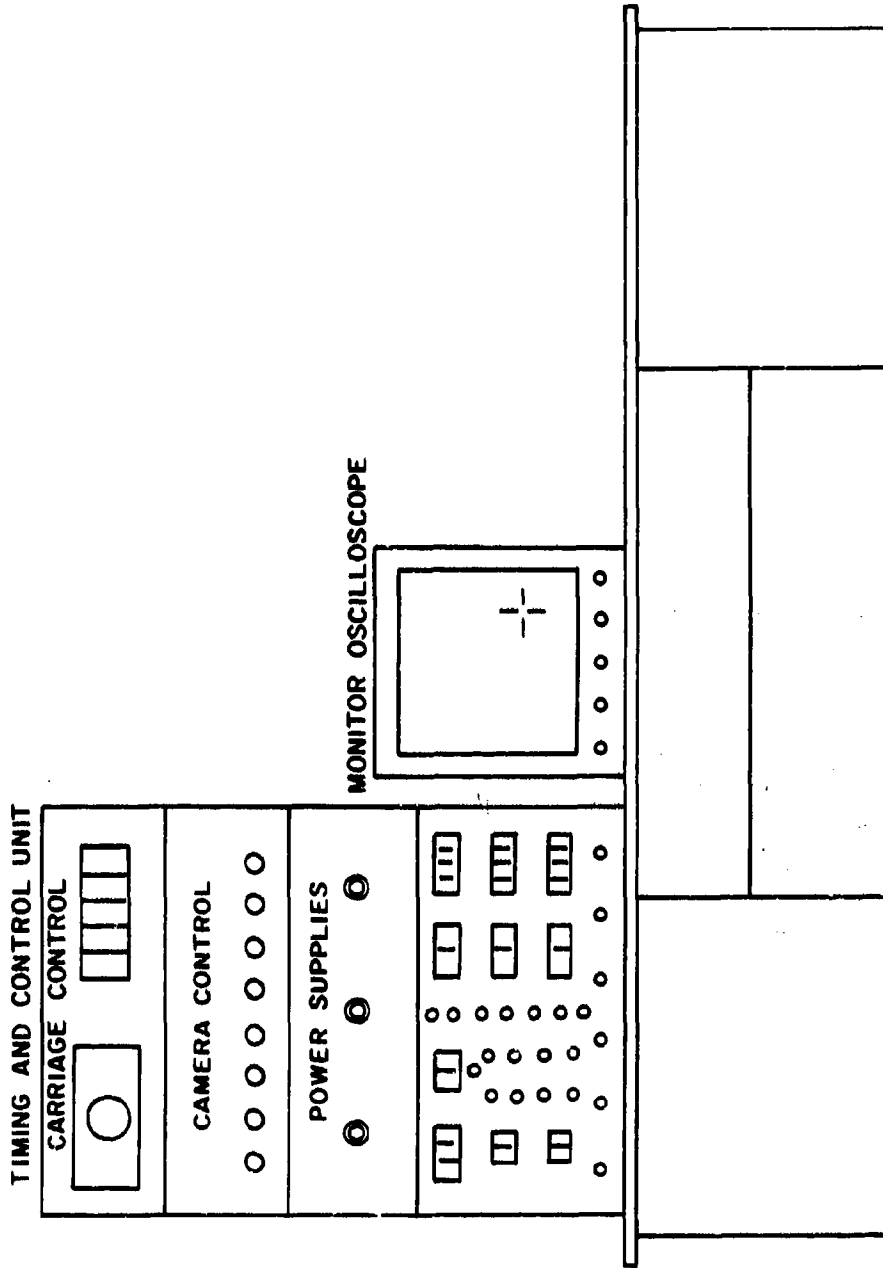

Fig. 13 - Test controller's position (C)

CONFIDENTIAL

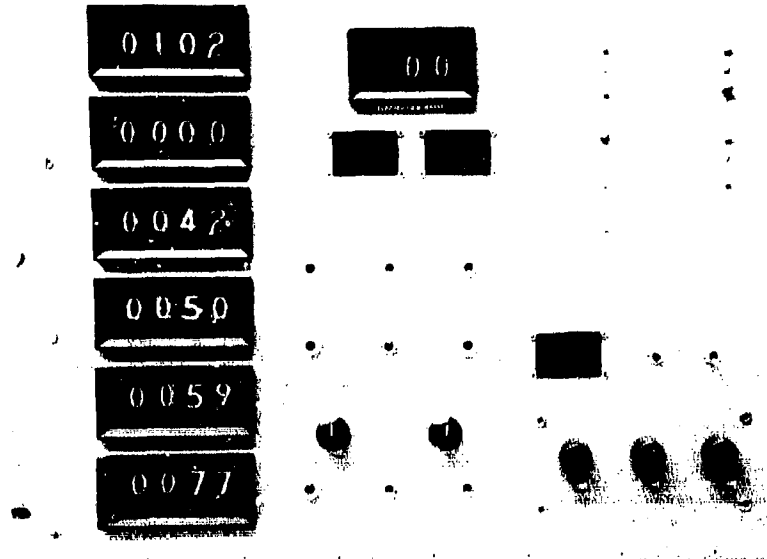

Fig. 14 - Test controller's control panel (C)

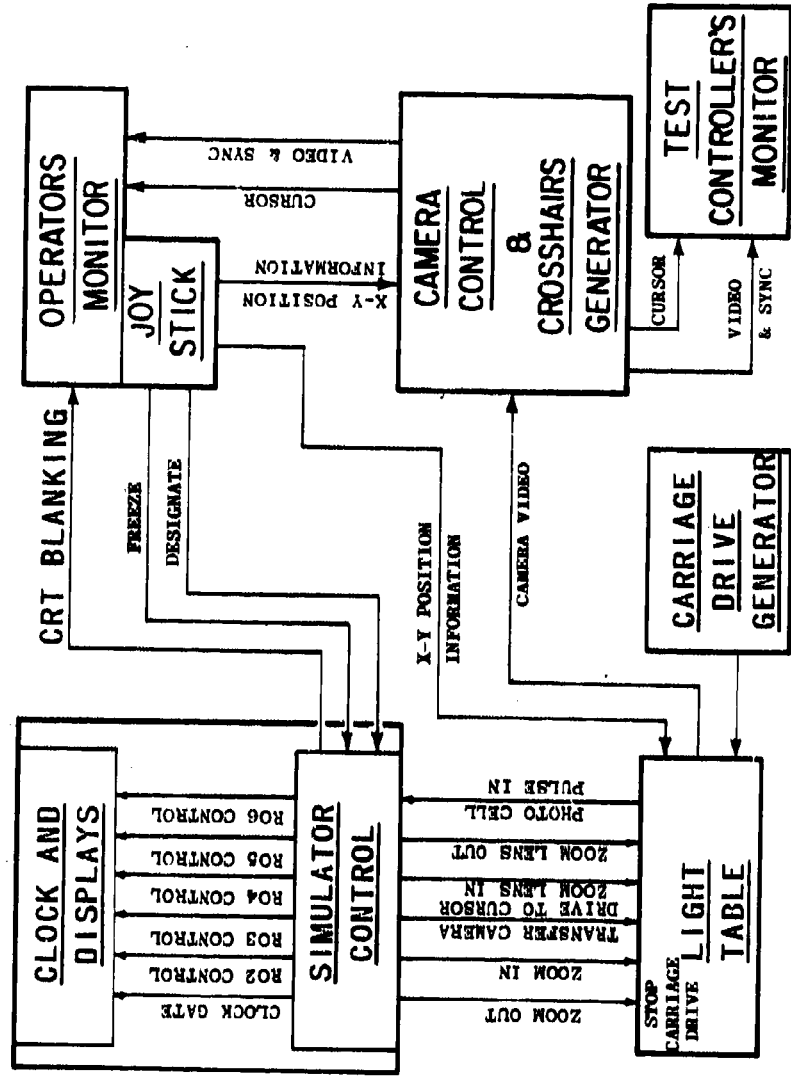

Fig. 15 - Simulator functional block diagram (C)

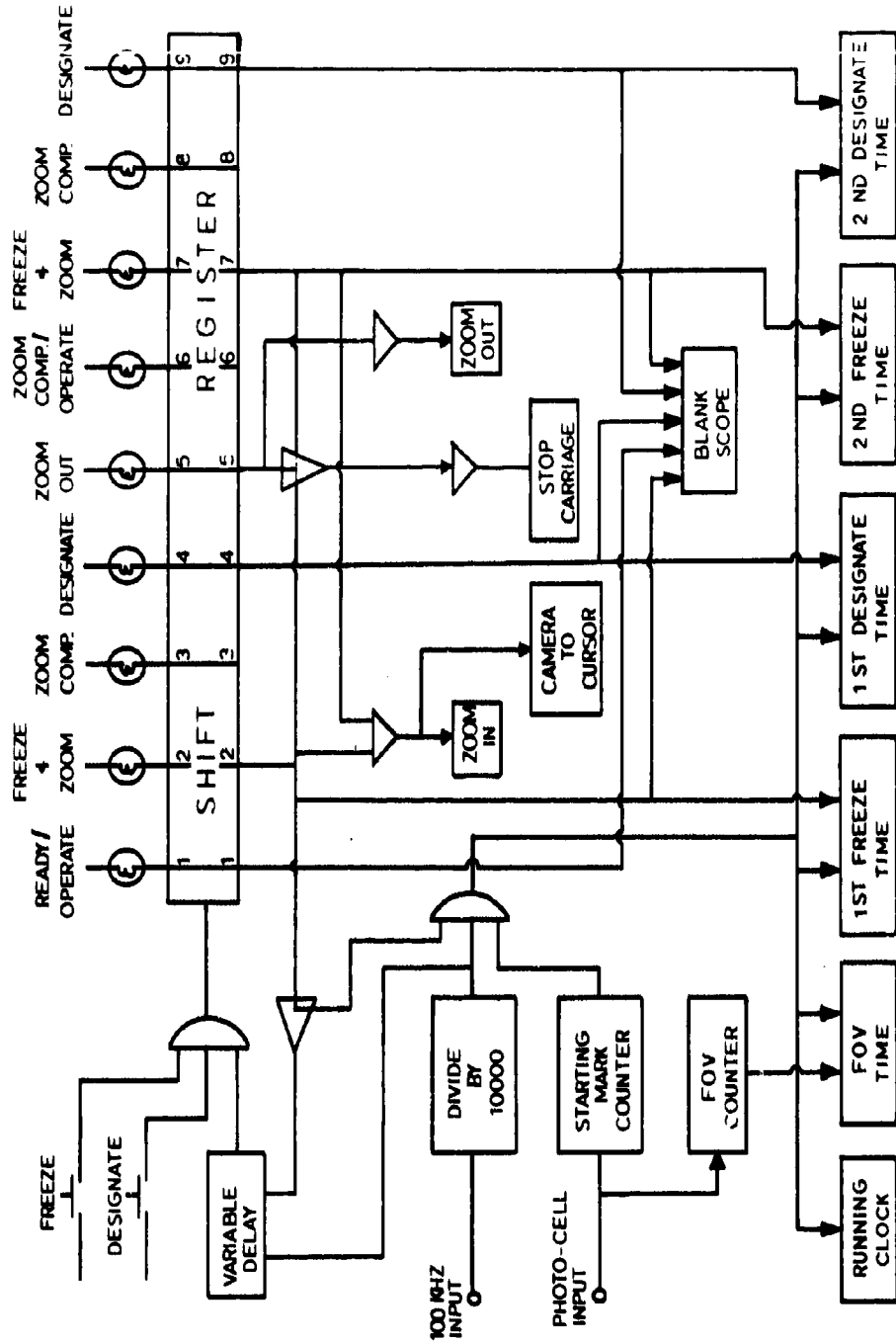

Fig. 16 - Simulator control (C)

CONFIDENTIAL

DISTRIBUTION LIST

NAVAIRSYSCOM	AIR-5103E1 AIR-5333 AIR-5333C AIR-5333D AIR-5333E	
NADC	F. Sachs J. Goldfarb	
NAFI	P. Brink	
NWC	H. Hoffman (3013)	
NRL	5308 5320 5330 5340 5350 5360 5361 5363 5364 5367 5370	
Hughes A/C Co., Culver City, Calif.	J. Kotlarski M. Wehrauch	
Westinghouse, Aerospace	L. Atran Dr. J. Walter	
Defense Documentation Center, Alexandria, Va. Attn: TIPDR		20

CONFIDENTIAL

CONFIDENTIAL

Security Classification

DOCUMENT CONTROL DATA - R & D

(Security classification of title, body, abstract and index entries is the same as that of the report to which this report is classified)

1. CONTRACT OR GRANT NO. Naval Research Laboratory Washington, D.C. 20390		2. SECURITY CLASSIFICATION CONFIDENTIAL	
3. REPORT TITLE SIMULATION FACILITY USING SENSOR IMAGERY FOR TACTICAL PROBLEM INVESTIGATIONS - SUMMARY REPORT (U)			
4. DESCRIPTIVE NOTES (Type of report and inclusive dates) Work on the overall problem is continuing. This is a summary report on the development of the NRL simulation facility.			
5. AUTHOR(S) (First name, middle initial, last name) B. Kremer, G. Hermann, J. Pavco, J. Ryon			
6. REPORT DATE April 1, 1970		7a. TOTAL NO. OF PAGES 40	7b. NO. OF REFS 16
8a. CONTRACT OR GRANT NO. NRL Problem D01-03		9b. ORIGINATOR'S REPORT NUMBER(S) NRL Memorandum Report 2150	
8b. PROJECT NO. A36-533/652-1/W11-180-00 A36-533/652-1/F17-343-604		9a. OTHER REPORT NO(S) (Any other numbers that may be assigned this report)	
10. DISTRIBUTION STATEMENT In addition to security requirements which apply to this document and must be met, each transmittal outside the agencies of the U.S. Government must have prior approval of Director, Naval Research Laboratory, Washington, D.C. 20390.			
11. SUPPLEMENTARY NOTES		12. SPONSORING MILITARY ACTIVITY Department of the Navy (Naval Air Systems Command) Washington, D.C.	
13. ABSTRACT (Unclassified) This report describes the development effort on an in-house simulation facility which uses sensor imagery for tactical problem investigations. Examples of the planned role of the simulation facility in the design and development of Navy air-to-surface weapon systems are given. An example of the operational problem which will be investigated using the simulation facility is described. The plans for growth of the facility to permit simulation of additional Navy tactical problems are outlined.			

14 KEY WORDS	LINK A		LINK B		LINK C	
	ROLE	WT	ROLE	WT	ROLE	WT
Tactical and systems analyses Airborne weapon control systems Simulation facility Sensor imagery Stand-of air-to-surface missile delivery						

**Naval Research Laboratory
Technical Library
Research Reports Section**

DATE: August 22, 2002
FROM: Mary Templeman, Code 5227
TO: Code 5300 Paul Hughes
CC: Tina Smallwood, Code 1221.1 *to 8/19/03*
SUBJ: Review of NRL Reports

Dear Sir/Madam:

Please review NRL Memo Reports 2139, 2150, 2170, 2297, 2360, 2425, 2426 and 2429 for:

- Possible Distribution Statement
- Possible Change in Classification

Thank you,

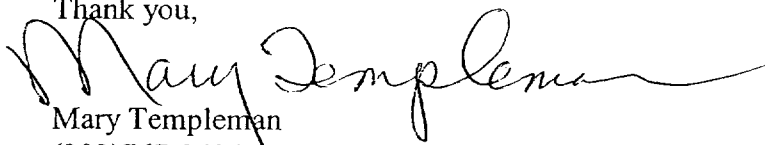
Mary Templeman
(202)767-3425
maryt@library.nrl.navy.mil

The subject report can be:

- Changed to Distribution A (Unlimited)
- Changed to Classification _____
- Other:

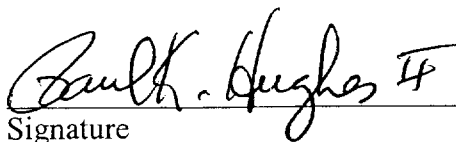
 *Paul Hughes* *IF* *8/18/2003*
Signature Date

- 1 OF 1
- 1 - AD NUMBER: 510904
- 2 - FIELDS AND GROUPS: 14/2, 16/4.1, 19/5
- 3 - ENTRY CLASSIFICATION: UNCLASSIFIED
- 5 - CORPORATE AUTHOR: NAVAL RESEARCH LAB WASHINGTON D C
- 6 - UNCLASSIFIED TITLE: SIMULATION FACILITY USING SENSOR IMAGERY
-- FOR TACTICAL PROBLEM INVESTIGATIONS.
- 8 - TITLE CLASSIFICATION: UNCLASSIFIED
- 9 - DESCRIPTIVE NOTE: SUMMARY REPT.,
- 10 - PERSONAL AUTHORS: KREMER,B. ;HERMANN,G. ;PAVCO,J. ;RYON,J. ;
- 11 - REPORT DATE: 1 APR 1970
- 12 - PAGINATION: 40P MEDIA COST: \$ 7.00 PRICE CODE: AA
- 14 - REPORT NUMBER: NRL-MR-2150
- 16 - PROJECT NUMBER: NRL-D01-03, A36-533/652-1/W11-180-00
- 20 - REPORT CLASSIFICATION: CONFIDENTIAL
- 22 - LIMITATIONS (ALPHA): DISTRIBUTION: USGO: OTHERS TO DIRECTOR,
-- NAVAL RESEARCH LAB., WASHINGTON, D. C. 20390.
- 23 - DESCRIPTORS: (*TACTICAL WEAPONS, *SIMULATORS), (*IMAGES,
-- SIMULATION), DETECTORS, TARGET ACQUISITION, TEST FACILITIES,
-- INTEGRATED SYSTEMS
- 24 - DESCRIPTOR CLASSIFICATION: UNCLASSIFIED
- 27 - ABSTRACT: THIS REPORT DESCRIBES THE DEVELOPMENT EFFORT ON AN IN-
-- HOUSE SIMULATION FACILITY WHICH USES SENSOR IMAGERY FOR TACTICAL
--
-- PROBLEM INVESTIGATIONS. EXAMPLES OF THE PLANNED ROLE OF THE
-- SIMULATION FACILITY IN THE DESIGN AND DEVELOPMENT OF NAVY AIR-TO-
-- SURFACE WEAPON SYSTEMS ARE GIVEN. AN EXAMPLE OF THE OPERATIONAL
-- PROBLEM WHICH WILL BE INVESTIGATED USING THE SIMULATION FACILITY IS
-- DESCRIBED. THE PLANS FOR GROWTH OF THE FACILITY TO PERMIT
-- SIMULATION OF ADDITIONAL NAVY TACTICAL PROBLEMS ARE OUTLINED.
-- (AUTHOR)
- 28 - ABSTRACT CLASSIFICATION: UNCLASSIFIED
- 29 - INITIAL INVENTORY: 20
- 32 - REGRADE CATEGORY: C
- 33 - LIMITATION CODES: 3
- 34 - SOURCE SERIES: S
- 35 - SOURCE CODE: 251950
- 36 - ITEM LOCATION: DTIC
- 38 - DECLASSIFICATION DATE: OADR
- 40 - GEOPOLITICAL CODE: 1100
- 41 - TYPE CODE: N
- 43 - IAC DOCUMENT TYPE:

APPROVED FOR PUBLIC
RELEASE - DISTRIBUTION
UNLIMITED