

UNCLASSIFIED

AD NUMBER

AD520062

CLASSIFICATION CHANGES

TO: unclassified

FROM: confidential

LIMITATION CHANGES

TO:
Approved for public release; distribution is unlimited.

FROM:
Distribution authorized to DoD and DoD contractors only; Foreign Government Information; SEP 1971. Other requests shall be referred to British Embassy, 3100 Massachusetts Avenue, NW, Washington, DC 20008.

AUTHORITY

DSTL, DEFE 15/2105, 9 Feb 2009; DSTL, DEFE 15/2105, 9 Feb 2009

THIS PAGE IS UNCLASSIFIED

AD 520062



PICATINNY ARSENAL
SCIENTIFIC RESEARCH AND DEVELOPMENT BRANCH
MINISTRY OF DEFENCE



ROYAL
ARMAMENT RESEARCH AND DEVELOPMENT
ESTABLISHMENT

1451426

EXPLOSIVES DIVISION

R.A.R.D.E. MEMORANDUM 32/71

The assessment of smoke interference with
the visibility of missile tracking beacons

Part I. General observations on the smoke problems
and trials of Rapier missile components

(title UNCLASSIFIED)

Miriam Budgen

N. R. Williams

INV 90

RECEIVED
JUN 5 1972
RECEIVED
D.
PTC
1451426

20090106 199

PD 13951

cont # 115744

REFERENCE ID:
 WHITE SECTION
 BUFF SECTION
 MAN. C.D.
 JUSTIFICATION:
 BY:
 DISTRIBUTION AVAILABILITY CODES:
 MIL. and/or SPECIAL

This Document was Graded
CONFIDENTIAL
 at the 261st meeting of the R.A.R.D.E.
 Security Classification Committee

THIS DOCUMENT IS THE PROPERTY OF HER BRITANNIC MAJESTY'S GOVERNMENT, and is issued for the information of such persons only as need to know its contents in the course of their official duties.

 Any person finding this document will hand it in at a Military Unit or Police Station for its safe return to THE SECOND PERMANENT UNDER-SECRETARY OF STATE (ARMY), MINISTRY OF DEFENCE, LONDON, S.W.1, with particulars of how and where found. THE UNAUTHORISED RETENTION OR DESTRUCTION OF THE DOCUMENT IS AN OFFENCE UNDER THE OFFICIAL SECRETS ACTS OF 1911-1939.

RELEASE CONDITIONS FOR OVERSEAS DISTRIBUTION

- | | |
|----------|--|
| A | 1. THIS INFORMATION IS RELEASED BY THE UK GOVERNMENT TO THE RECIPIENT GOVERNMENT FOR DEFENCE PURPOSES ONLY.

2. THIS INFORMATION MUST BE ACCORDED THE SAME DEGREE OF SECURITY PROTECTION AS THAT ACCORDED THERETO BY THE UK GOVERNMENT.

3. THIS INFORMATION MAY BE DISCLOSED ONLY WITHIN THE DEFENCE DEPARTMENTS OF THE RECIPIENT GOVERNMENT AND TO ITS DEFENCE CONTRACTORS WITHIN ITS OWN TERRITORY EXCEPT AS OTHERWISE AUTHORISED BY THE MINISTRY OF DEFENCE. SUCH RECIPIENTS SHALL BE REQUIRED TO ACCEPT THE INFORMATION ON THE SAME CONOITIONS AS THE RECIPIENT GOVERNMENT.

4. THIS INFORMATION MAY BE SUBJECT TO PRIVATELY-OWNEO RIGHTS. |
| B | 1. THIS INFORMATION IS RELEASED BY THE UK GOVERNMENT TO THE RECIPIENT GOVERNMENT FOR DEFENCE PURPOSES ONLY.

 2. THIS INFORMATION MUST BE ACCORDED THE SAME DEGREE OF SECURITY PROTECTION AS THAT ACCORDED THERETO BY THE UK GOVERNMENT.

 3. THIS INFORMATION MAY BE DISCLOSED ONLY WITHIN THE DEFENCE DEPARTMENTS OF THE RECIPIENT GOVERNMENT AND TO THOSE NOTED IN THE ATTACHEO LIST, EXCEPT AS OTHERWISE AUTHORISED BY THE MINISTRY OF DEFENCE. SUCH RECIPIENTS SHALL BE REQUIRED TO ACCEPT THE INFORMATION ON THE SAME CONDITIONS AS THE RECIPIENT GOVERNMENT.

 4. THIS INFORMATION MAY BE SUBJECT TO PRIVATELY-OWNED RIGHTS. |
| C | 1. THIS INFORMATION IS RELEASED BY THE UK GOVERNMENT TO THE RECIPIENT GOVERNMENT FOR DEFENCE PURPOSES ONLY.

 2. THIS INFORMATION MUST BE ACCORDED THE SAME DEGREE OF SECURITY PROTECTION AS THAT ACCORDED THERETO BY THE UK GOVERNMENT.

 3. THIS INFORMATION MAY BE DISCLOSED ONLY WITHIN THE DEFENCE DEPARTMENTS OF THE RECIPIENT GOVERNMENT, EXCEPT AS OTHERWISE AUTHORISED BY THE MINISTRY OF DEFENCE.

 4. THIS INFORMATION MAY BE SUBJECT TO PRIVATELY-OWNED RIGHTS. |
| D | 5. THIS INFORMATION IS RELEASED FOR INFORMATION ONLY AND IS TO BE TREATED AS DISCLOSED IN CONFIDENCE. THE RECIPIENT GOVERNMENT SHALL USE ITS BEST EN-OEAVOURS TO ENSURE THAT THIS INFORMATION IS NOT DEALT WITH IN ANY MANNER LIKELY TO PREJUICE THE RIGHTS OF ANY OWNER THEREOF TO OBTAIN PATENT OR OTHER STATUTORY PROTECTION THEREFOR.

6. BEFORE ANY USE IS MADE OF THIS INFORMATION FOR THE PURPOSE OF MANUFACTURE THE AUTHORISATION OF THE MINISTRY OF DEFENCE, O SALES (SALES 5a (A)), ST. CHRISTOPHER HOUSE, SOUTHWARK STREET, LONDON S.E.1 MUST BE OBTAINED. |

CONFIDENTIAL

MINISTRY OF DEFENCE

ROYAL ARMAMENT RESEARCH AND DEVELOPMENT ESTABLISHMENT

R.A.R.D.E. MEMORANDUM 32/71

AD-520062

The assessment of smoke interference with
the visibility of missile tracking beacons

Part I. General observations on the smoke problems
and trials of Rapier missile components
(title UNCLASSIFIED)

Miriam Budgen)
N. R. Williams) E3

Summary

A major problem with guided missiles which rely on visual or instrumental detection of light sources on the missile, in order to obtain information on the missile position relative to a target, is attenuation of the radiation emitted from such a source by missile smoke. Additionally smoke may obscure the target. A technique has been devised for measurement of the radiation attenuating properties of the smoke emitted by missile components, either separately or in combination, under simulated flight conditions. The values so obtained for a particular missile (Rapier) have been found comparable with the limited data available from free flight firings, establishing reasonable confidence in the ability to use data obtained under these controlled conditions to predict effects in operational use. An important finding was that smoke measurements made under static conditions (no relative air flow) do not correlate with results obtained from dynamic firings (relative air flow - free flight or wind tunnel conditions).

Approved for publication:

D. F. Runnicles, Principal Superintendent, 'E' Division

This material contains information affecting
the national defense of the United States
within the meaning of the Espionage Laws
(Title 18, U.S.C., sections 793 and 794),
the transmission or revelation of which in
any manner to an unauthorized person is
prohibited by law.

EXCLUDED FROM AUTOMATIC
REGRADING; DOD DIR 5200.10
DOES NOT APPLY

D D C
RECEIVED
JUN 5 1972
RECEIVED
D

CONFIDENTIAL

CONFIDENTIAL

	<u>CONTENTS</u>	<u>Page</u>
1.	Introduction	1
2.	Static Smoke Measurements	2
3.	Dynamic Smoke Measurements	4
4.	Trials of the Rapier Missile	6
	4.1 Introduction	6
	4.2 Objectives of Trial	6
	4.3 Experimental	7
	4.4 Firing Schedule and Procedures	10
	4.5 Observations on Measurement System Operation	11
	4.6 Results	13
	4.7 Discussion of Results	16
	4.8 Conclusions	19
	4.9 Recommendations	21
5.	Discussion on Smoke Measurement	22
6.	Conclusions	23
7.	Recommendations	23
8.	Acknowledgements	23
9.	Bibliography	24
	Appendix I	25
	Appendix II	27
	Appendix III	33
	Tables 1 - 6	35-50
	Figures 1 - 22	

IMPORTANT

This document should be returned to the Reports Officer, Royal Armament Research and Development Establishment, Fort Halstead, Sevenoaks, Kent. when no longer required

INITIAL DISTRIBUTION

Internal

- No. 1 Director
2 Deputy Director (1)
3 Deputy Director (2)
4 SMO
5 PS/E
6 PS/A
7 PS/B
8 PS/C
9 PS/D
10 Dr C K Thornhill
11 SNO
12 SAFO
13 S/E3
14 S/A2
15 S/C1
16 S/C2
17 S/D4
18-22 E3 (Attn Mr R A Awcock, Mr D Izod, Mr P Pelham, Mr F P Watkins,
Mr N Williams)

External (UK)

- 23 Chief Scientist (Army)
24 Controller Research (Av Supply)
25 Deputy Chief Scientist (Army)
26 DGW(A)(WPNS Coord(A))
27 WPNS Coord(A)c
28 GW(G&C)5, Castlewood House
29 GW(P&W)3, Prospect House (Attn Mr J C Litton)
30 AD/GW(M)B, Castlewood House (Attn Lt Col I Peck)
31 GW(M4, Castlewood House (Attn Major G Carter)
32 Secretary, OB
33 MOD Library (Central & Army)
34 ASWE, Navy Dept, Portsmouth, Gosport, Hants (Attn Mr E J Underhill)
35-36 RRE, St Andrew's Rd, Malvern, Worcs (Attn Lt Col K Grantham-Wright,
Mr J S Bickerdike)
37-42 BAC, Six Hills Way, Stevenage, Herts (Attn Mr E Drury, Mr D J Poole,
Mr W Bowron, Mr S Dunn, Mr P Wise, Mr D Green)
43 BAC, Warton, Preston, Lancs (Attn Mr J Smith, GW Wind Tunnel)

CONFIDENTIAL

CONFIDENTIAL

External (UK) (Cont'd)

44-45 IMI Ltd, Kidderminster, Worcs (Attn Mr G Haefeli, Mr B Johnson)

46 TRC - for retention

Overseas (through TRC)

47 BDSW (R&D) (Attn Director of Munitions

48 BDLs (Army) Ottawa (Attn Lt Col P Camp)

49-51 Canada - CFHQ for DCENG Technical Library

52-55 - Def Res Board

56 - CDLS

57 Australia - AAS(UK)

58-62 - Dept of Supply

63 - RAAF Overseas HQ, London

64-78 USA - ONR (London)

79 - Assist Sec of Def (Dep DDR & E)

80 - Defense Documentation Center, Cameron Station,
Alexandria, Va 22314

81-85 - US Army Standardization Group, UK

Stock

86-92

CONFIDENTIAL

1. INTRODUCTION

A number of guided missiles, either in Service or under development in the UK, depend for their successful operation on the transmission of visible radiation from a source (beacon) on the missile to a ground control station. Reception of the radiation may be direct (visual observation with the unaided eye) direct-aided (use of optical sight) or by electro-optical instrumentation. In general the tracker also views the target and the usual mode of operation is to issue instructions to the missile through the guidance control link, to change the direction of flight until the observed light source on the missile is coincident with the target, with the aim thereafter to so direct the missile that this coincidence is maintained. Because of requirements to engage targets at short ranges the system is usually designed such that the missile is brought on to the control to target line of sight as quickly as possible, and in this case ideally the missile beacon is superimposed over the target throughout the flight.

In order that the missile shall be detectable by the tracker (whether this is the human eye, aided or unaided, or an electro-optical device) a certain minimum amount of radiation must be received in relation to that received from the general background. It is relatively easy to produce pyrotechnic light sources to meet the needs of adequate contrast against most backgrounds and of sufficient size to provide an adequate signal level. However, pyrotechnic light sources produce smoke. So do rocket motors and other missile components, notably gas generators. Problems arise, due to accumulation of smoke along the line of sight, if the missile is flown along a line of sight which is itself static or moving relatively slowly to the local atmosphere. If the target has a moderate crossing velocity component perpendicular to the line of sight, then, if the missile is controlled to maintain coincidence of missile beacon and target images in the tracker, the missile flies a curved path. Barring wind movement of smoke, the line of sight will not intersect a significant section of the smoke trail.

However, targets of slow relative angular crossing velocity (aircraft in head-on approach, helicopters and armoured vehicles) are of high military significance and smoke attenuation of missile beacon signals and target obscuration becomes of great concern.

The palliative of flying a missile along a line parallel to but displaced from, the line of sight and bringing it on to the target line of sight as late as possible involves the likelihood of missing the target (by flying the missile beyond it) unless the varying range of the missile from the target is known. With the majority of current or proposed systems such information is not available.

The work described in this Memorandum arose out of consideration of the visibility of a beacon and includes a method of quantitatively estimating the attenuation, by smoke, of a tracking beacon radiance during flight. However the results are also pertinent to the problems of contrast of a beacon and target against the background, since attenuation by smoke leads to degradation of this contrast.

The method depends on experimental measurement of the smoke emission

CONFIDENTIAL

and light emission from a beacon under particular, controlled conditions, using a wind tunnel, and the insertion of the empirical data into a mathematical model of the smoke trail produced by a missile in free flight. The method has been tested using Rapier missiles, and reasonable correlation found between prediction from these ground trials and the very limited information available from free flight trials.

This Memorandum also includes data which show conclusively that attempts to correlate the results from smoke measurement trials made under static conditions, (no high speed relative air-flow over the component under test), with dynamic trials have not been successful. The results from static trials have in fact been positively misleading in that tracking flares or rocket motors, which on static test were less smoky than others, turned out to be the reverse under dynamic conditions.

2. STATIC SMOKE MEASUREMENTS

Before it was fully appreciated that the smoke emission characteristics of missile components were so dependent on the environmental conditions as to render measurements under static conditions virtually useless, a number of experiments were conducted under static conditions. It is now realised that the quantitative results obtained from such experiments are of value only when compared with the results of dynamic firings to demonstrate the necessity for dynamic firings if meaningful information is to be obtained. It is however worth recording some of these experiments because they did have an important influence on the experimental technique subsequently successfully used for measurement of smoke under dynamic firing conditions.

An attempt was made by IMI Summerfield to determine quantitatively the density of the smoke plume produced by the Troy rocket motor, used in the Rapier missile, by measuring the attenuation of beams of white light (from tungsten filament lamps) directed across the smoke cloud produced by motors fired statically in the open. No attempt was made to control the geometry of the smoke cloud which varied very considerably from experiment to experiment depending on the local atmospheric conditions and this induced a high level of variability into the attenuation measurements. The only positions in which the smoke plume maintained a reasonably reproducible geometry was close to the motor, where the plume is narrow. This introduced experimental problems because of the short path lengths and, because the plume was narrow, small changes in dimensions became significant and such changes were observed to occur. These factors lead to considerable doubts as to the meaning of the experimental numerical data and generally the results were judged to be of dubious value. In some of these tests a lamp was positioned some 80 metres behind the motor and the intensity monitored through the smoke from a position near the motor. These results were also very variable due to the variability in the smoke cloud formed between the motor and the photometer. Over and above any considerations on the value of the experimental data on radiation attenuation it was also thought that the basic characteristics of the smoke might be different as the motor was fired statically. In a dynamic situation air entrainment, which could affect the later stages of combustion of the rocket exhaust gases, could be significantly different as could be the rates of cooling of the gases (of importance if condensation of water vapour

is a significant factor in determining the optical properties of the exhaust cloud). These experiments are discussed more fully in Reference 1.

One conclusion which emerged from these trials was that if any useful smoke measurements were ever to be made, it was essential to control the geometry of the smoke cloud. The most obvious way of achieving this was considered to be firing of the smoke-producing device at one end of a tube, open at both ends and preferably of uniform cross section, and measuring the optical properties of the smoke while it was travelling through the tube. The geometry would be known and rates of flow could be measured. The major foreseeable problems were thought to be smoke density gradients across the tube, and condensation on the walls. The arguments concerning the possible differences between the basic properties of the smoke occasioned by static firings as compared with dynamic firings remained. However, at that time, the evidence for such differences was not conclusive and it was considered worthwhile pursuing a satisfactory technique for static test measurements. RARDE went ahead with development of static test equipment in order to assess quantitatively various proposals which had been generated during considerations of means of reducing the amount of smoke produced by missile tracking flares.

An attempt had been made at one time by RARDE to use a horizontal tunnel for measurement of the smoke produced by combustion processes but had not been successful, probably due to non-uniformity of smoke distribution across the tunnel caused by natural convection of heated combustion products and excessive turbulence in the tunnel. The tunnel was rectangular in cross section and a forced draft of air from a fan was used to transport the smoke through the tunnel. No attempts were made to smooth out turbulence in the fan-driven air. In more recent experiments, a vertical tube was used to circumvent any problems with non-uniformity due to convection. Natural convection was in fact used as the means of transporting the smoke through the tube. This gave a much less turbulent flow than in the previous experiments. The flow velocity and the attenuation of light beams directed horizontally across the tube were measured at three different levels above the flares. Consistent results were obtained with no evidence of significant smoke condensation on the tube and a programme of evaluation of various designs of tracking flares was started. Additionally the equipment was used to measure the smoke produced by the gas generator charges used to actuate the guidance fins on the Rapier missile. The equipment is described in more detail in Appendix I.

The work on flares indicated that a change to an alternative liner material for the Rapier flare would be a worthwhile improvement. At that time the current design of flare for Rapier included a thin liner of Lantex* and it was found that a Kemetal^φ liner produced significantly less smoke. Experiments were carried out with various thicknesses of Kemetal liners. The flares with thicker liners gave rise to less smoke. The radiant outputs were also lower because of the reduced burning surface area (the outside diameter of the flare was retained invariant - any change would have reflected on

* A Lantex liner is a mandrel wound tube made from a phenolic resin impregnated paper.

^φ A Kemetal liner is a tube machined from a rod of a polyacetal copolymer.

CONFIDENTIAL

other missile components). An optimum thickness was chosen, after smoke and radiance measurements, for use on further trials.

In this smoke-measurement system, when the velocity of the smoke column are known, it is possible to calculate the attenuation over any other path length and for any velocity if certain assumptions are made. These are that:-

- a. the optical properties (absorption and scattering etc.) of the smoke remain unaltered between the first condition and the second.
- b. the optical properties of the smoke are uniform along the column.
- c. the attenuation by the smoke follows Beer-Lambert's Law.
- d. the rate of smoke output is constant.

A mathematical model of the geometry and internal smoke concentrations of the visible trail generated by a Rapier missile in free flight has been produced by BAC. The data from the static test experiments was fed into this model as is described in Appendix II. This gave a set of predictions for the attenuation of the tracking flare radiation by the smoke produced by the flares and gas generators.

3. DYNAMIC SMOKE MEASUREMENTS

The predictions referred to in Section 2 were treated with considerable scepticism because of a growing opinion that not enough was known about the possible interaction between missile components (motors, flares and gas generators) and about the effects of a change from static to dynamic conditions. This opinion was supported by subjective observations, based on films of missile firings and some recordings from missile trackers made during tests of Swingfire motors. It was increasingly apparent that dynamic trials had to be conducted in order to settle the argument over the validity of applying static test data to dynamic conditions. It was also very necessary to make smoke measurements on missile motors and the Swingfire test experience demanded that these be dynamic tests. It was therefore decided to proceed to develop a dynamic test equipment. It was necessary that this equipment meet two requirements:-

- a. that the smoke be produced under conditions of combustion representative of missile flight conditions with all combustible systems burning together, to allow for any interactions between the different effluxes. Only in this way could it be reasonably expected that the observed smoke would have the same chemical composition (with extra air entrainment), the same particle size distribution and particle shape, as that produced by a missile in free flight. For instance, the flare flame is rich in unburnt titanium, the rocket efflux is rich in oxidizing gases such as carbon dioxide and water vapour and some interaction is probable. The cool-burning cordite charges of the gas generators produce a black carbon smoke which again may be raised to a sufficiently high temperature to burn in the air, carbon dioxide

or water vapour.

b. that the smoke be confined into a known geometry with some means of ensuring uniform distribution throughout this geometry whilst maintaining a velocity in the column so that measurements could be made on the smoke before settlement took place.

If the above two requirements were met, then a good measure of confidence could be given to calculations extrapolating from these conditions to missile flight conditions.

The immediate requirements were to obtain data for the development of the Rapier missile. Condition (a) above presented the major problem. The Rapier missile achieves a maximum velocity in the region of Mach. 2 and is intended primarily for attack of low flying aircraft. The latter was fortunate in that altitude effects could reasonably be excluded from the flight environmental simulation. Fortunately the BAC wind tunnel at Warton, Lancs. in addition to a capability to operate in its design role as a Mach 1.7 to 6.0 blow-down wind tunnel, can also provide an intermittent blowing facility capable of giving test airflows representative of sea level flight conditions at speed ranges up to Mach 1.2 (with correct air temperature simulation if required) (Refs. 2 and 3). This speed range can be achieved using an 18 inch nozzle, combined with a fairing on the missile body to give supersonic speeds. The exit from the nozzle is open to the atmosphere so there is no danger of damage to the blower facility from combustion products or debris. Also accidental explosion of a store under test would probably damage only the exit nozzle, which is relatively readily replaceable (as compared with the main working section). The maximum windspeed available ($M = 1.2$) represented an approximately median condition for Rapier and the available blowing time at this speed was in excess of the maximum Rapier missile flight time. It was considered therefore that the BAC Warton blower could provide reasonable simulation of flight environmental conditions around the missile itself, sufficient for the purpose of initial evaluation of the smoke emission in relation to tracking system performance.

For smoke measurement the techniques developed for static measurements were applied. A long cylindrical tube was set up downstream of the tunnel exit nozzle and co-axial with the nozzle. The length of the tube was chosen such that reasonably laminar flow conditions would be expected to have been established within the first half of the tube when the tunnel was operating, and measurements on smoke properties were made in the second half of the tube. The diameter of the tube was chosen on the basis of known data on rocket exhaust expansion rates (with distance from the rocket nozzle) such that all the combustion products of the missile should enter the tube. With an airflow velocity of Mach 1.2 convective forces were deemed negligible (i.e. the fact that the smoke measurement tube was horizontal instead of vertical was of no significance) and the major consideration in design of the tube was that of achieving sufficient length to reduce gross turbulence before the measuring stations were reached. Various systems all based on attenuation of light were fitted to the tube to measure smoke density. As will be shown this equipment proved highly successful as a means of obtaining the required information.

CONFIDENTIAL

4. TRIALS OF THE RAPIER MISSILE

4.1 Introduction

Rapier is an optically tracked line of sight missile and subject to the potential deficiency discussed in Section 1 of this report. The beacon on the missile is a cluster of 4 pyrotechnic flares, ignited parasitically from the boost motor exhaust on launch. Ignition of 3 flares is sufficient for successful tracking in the absence of smoke interference. There are three smoke emitters, the rocket motor (boost and sustainer), the flares, and a gas generator which provides power for guidance control. Under the worst conditions, in which all of the emitted smoke accumulates along the line of sight during missile flight, there is a very high probability that attenuation of the radiation from the tracking flares will be so high that the missile is 'lost' by the tracker. There existed a specific need to be able to quantify the amount of smoke being generated at any time by each of the missile components which produce smoke in order to assess the most profitable areas for further development aimed at smoke reduction and, secondly, for studies directed at determination of the probability of any missile in a complex being able to successfully engage a target.

It was known that a high speed air flow in the direction of the flare axis caused a significant decrease in output. Reduction by factors in the range 33:1 to 11:1 have been reported for flares flown at velocities of the order of Mach 2.0. These results possibly included the effect of attenuation of the flare output by smoke and were partly confirmed in experiments in which the exhaust from a jet engine was used to produce high speed flow around a streamlined body into which a flare was mounted. This simulation of flight conditions was relatively crude - the flow velocity was sub-sonic, the windstream turbulent and composed of hot products of combustion from the engine. Quantitative data under more realistic flight simulation conditions were obviously desirable, the flare output data being essential to any assessment of the probabilities of loss of missile acquisition caused by smoke obscuration. Also the results of tests in the Warton facility could be compared with the jet windstream test results. If the results were generally similar, this would be a significant finding in that the jet windstream tests are much more easily carried out.

The trials described in the following sections were accordingly conducted using the BAC Warton wind tunnel during October 1969.

4.2 Objectives of Trial

The trial was carried out to

4.2.1 assess the ability of the wind tunnel/tube assembly arrangement to give reproducible smoke measurements for comparing the smoke producing parts of the missile system.

4.2.2 compare the light attenuation effect of the smoke produced by
a. gas generator

- b. Troy motor
- c. 4 Rapier flares

which are parts of the present missile system.

4.2.3 measure the radiant output from the Rapier flares through the smoke produced by all parts of the system under supersonic airflow conditions, and the radiant output from the flares not through smoke, under the same airflow conditions.

4.2.4 select the best flare 'improvements' by measuring smoke produced and the radiant output of two alternative types of flares as described in para. 4.4.1 (iv) and (v).

4.2.5 investigate the interaction of flares, motor and gas generator.

4.2.6 to generate the data needed for prediction of the attenuation effect of missile smoke in flight.

4.2.7 measure the radiation and smoke from a high output, fast burning flare, filled with composition SR 697 in order to assess its suitability for use during the gather phase of the missile. During this period a high radiant output was required as the missile was likely to have a high crossing velocity.

4.3 Experimental

4.3.1 General Arrangement

The store to be tested was mounted in the exit nozzle of the BAC Warton blowdown wind tunnel (Fig.1). Downstream from the nozzle, and co-axial with the nozzle was a metal tube 24.4 metres long and 0.61 metres in internal diameter with one end 2.44 metres from the nozzle exit. The tube was constructed from quarter inch thick mild steel rigidly supported on nine A-frames and was blackened inside to reduce reflections.

Theoretical considerations predicted that reasonably uniform distribution of smoke particles within a fast airflow through the tube would be established by the mid point of the tube (Ref. 4). Three independent smoke measurement systems were fitted to the second half of the tube giving a total of 8 information channels. This level of instrumentation was deemed necessary as this was the first experiment of this kind.

Flare radiation was measured by two radiometers. One was positioned off-axis to record the output from the flares in the absence of smoke attenuation; the other was positioned at the downstream end of the smoke measurement tube to record the radiation received through the confined smoke column. comparison of the two records gave a further measure of smoke attenuation.

Additionally the flow velocity in the smoke measurement tube was monitored together with data on the flow conditions in the nozzle. Cine photographic coverage was provided for most firings.

4.3.2 Airflow over stores

For the testing of flares only, the flares were mounted as shown in Fig. 2. The outer contour of the cylindrical mounting was considered to be a reasonable approximation to that of the aft section of the missile body. The forward end of the mounting was not closed but left open so that air would pass through the cylinder and give a central base flow to partly simulate the flow which would occur from the rocket motor in a 'live' firing. The flare-mounting cylinder was supported in an outer shell which fitted into the exit nozzle of the tunnel. The combination of nozzle and outer support shell were so designed to give supersonic flow ($M = 1.17$) in the region around the outer, rear portion of the flare mounting. Calibration measurements showed that for a given tunnel operating condition (designated condition X) in the absence of flame from the flares the flow conditions were as follows:-

- a. external flow over flare mounting at rear
Velocity: 378 metres/second (Mach 1.17)
Static temperature: -27°C
Static pressure: sea level, atmospheric
- b. Exit flow from central tube (6.35 cm diameter)
Velocity: Mach 1.0
Mass flow: 1.13 kilogrammes per second
Static temperature: 0°C
Static pressure: sea level, atmospheric

For the testing of rocket motors or gas generators alone or motors plus any other component the outer support shell and tunnel operating conditions had to be modified (to a tunnel condition designated Y) to achieve the same flow condition as at (a) above. The motor mounting is shown in Fig. 3.

When the tunnel operation was started these flow conditions were reached in about 1 second with a linear rate of rise of velocity with time over this period.

In each experiment, the firing pulses were applied before tunnel operation commenced. This was done to circumvent potential misfires due to breaking of firing circuit leads by the windstream. In fact the 1 second build up of flow velocity to the maximum value ($M=1.17$) obtainable in these experiments corresponds approximately to the time the missile would take to reach this speed when fired from rest.

Full windspeed could be sustained for 40 seconds which was greater than the maximum burning time of any component under test.

The relative times of application of the firing pulses and the start of tunnel operation were recorded. A common event marker was supplied to all recording channels including photographic, by the firing of a flash bulb, at the start of tunnel operation (zero time).

4.3.3 Smoke Measurement Systems

- a. Diagonal light path method

This was essentially the photocell and lamp method already

used in the RARDE smoke chimney but the path was angled across the tube to give a path length of 2.59 m. which was thought necessary to give sufficient attenuation in the highspeed smoke. Diffusing screens were placed in front of the detector and the lamp in order to obtain a large cross-section and hence a better sample of smoke. Four separate systems were used. (Figures 4(a) and 5). In two of these systems the detectors faced the burning source and in the other two they faced the tube exit as shown in Figure 5.

b. Sample tube method

A small bore tube was connected to the main tube so that a proportion of the smoke passed down it and was bled off to atmosphere using a suction fan. A laser beam was passed through a straight section of the tube either 4.1 metres or 7 metres long and the attenuated beam viewed by a silicon detector through a 100Å⁰ narrow band filter. The advantage of this system was that measurement was over a fairly long path length without interference from sparks. (Figures 6 and 7). A trap had been provided for large solid particles and this proved to be essential to avoid damaging the system windows.

c. Mirror method

The light from a laser was passed across the diameter of the tube and reflected a number of times by mirrors to increase the path length. The system was mounted independently on the ground to minimise vibration from the tube. By making 1, 3, 5 or 7 passes across the tube, path lengths of 2, 6, 10 and 14 ft could be obtained.

Three separate systems were provided (Figures 4(b) and 5) but one laser failed early in the trial and generally only two systems were operational.

4.3.4 Radiation Measurement Systems

a. Radiometry

Two radiometers were deployed at about 190 metres from the flares. One (radiometer A) was on the axis of the tube and hence measured the radiation through 26.8m of smoke. The other (radiometer B) was set up on a line at 19° to the tube axis and thus received the light from the flare without attenuation by the smoke. The layout is shown in Figures 8 and 9.

The instruments used were as described in Reference 5 except that the filters were changed to give the spectral response characteristics shown in Fig. 10, chosen to match the response characteristics of the TV tracker as closely as possible. The ratio between the measurements made by radiometers A and B gave a measure of the transmission through 26.8m of smoke.

b. TV tracker

A Rapier TV tracker was placed alongside the radiometer A, 190 metres from the wind tunnel in line with the tube. The spectral response characteristics of the TV tracker are shown in Figure 10. The response curve peaks at a similar wavelength to the radiometers but the TV tracker was more

sensitive at longer wavelengths. The AGC signal level in the TV tracker was recorded as a continuous function of time.

4.3.5 Ancillary Systems

a. Velocity and temperature of windstream in tube

Sets of Pitot tubes were stationed along the tube as shown in Figure 11 in order to obtain velocity profiles. The Pitot tubes stationed near the tube exit are shown in Figure 12(a) and in the wind tunnel nozzle in Figure 12(b). Measurements were made at all the Pitot tubes and the pressures recorded on magnetic tape. Temperatures were recorded by thermocouples at three stations along the tube and were used in the velocity calculations. When motors were fired Pitot tubes and thermocouples at the tube entrance, which were within the flame zone, were destroyed.

b. Closed circuit TV

It was intended to have closed circuit TV with video tape recording viewing end-on through the tube as shown in Figure 9 in order to help isolate any cause of trouble. Few recordings were obtained due to excessive dust on the tape under the field conditions.

c. Photography

Fastex and Bolex cine films were taken from a side-on position (Figure 9) for all rounds excluding firings of gas generators only. Many still photographs were taken.

4.4 Firing Schedule and Procedures

4.4.1 Stores fired during trial

Taking into account availability of stores, time and money, it was decided that a maximum of 3 runs of each type of firing was possible and that this represented a reasonable sample of each. The types of firings were:-

- (i) Troy motor
- (ii) Gas generator (Mechanite 14) for actuators
- (iii) Flares: Four SR 699 in 0.88 in. I.D., Lantex liner in steel case. (Standard Rapier flares)
- (iv) Flares: Four SR 699 in 0.88 in. I.D., Kemetal liner in steel case.
- (v) Flares: Four SR 699 in 0.75 in. I.D., Kemetal liner in steel case.
- (vi) Flares: Four SR 697 in 0.88 in. I.D., Lantex liner in steel case.
- (vii) Troy motor + gas generator + four standard flares.

Details of flares used are given in Figure 13.

All flares were primed with 3 gm of SR 44 and fitted with electric fuzeheads. In normal missile operation the flares are ignited parasitically from the motor exhaust. In these experiments, flares were fired separately from motors in some cases, necessitating electrical ignition.

Gas generators, used for the fin actuators, were mounted behind the motor as on the missile, with pipework and filters including the 'top hat' and vortex filters, but excluding the two fluid pressure filters (Ref. VAC 19978) and a small length of pipe. Prior to firing, ICI agreed that this might lead to a slightly too high a recording of smoke level (Figures 14 and 15).

Motors were manufactured both by IMI and ROF Bisphampton. Strakes were removed so that a thin aerodynamic shell could be fitted and a dummy wing ring section was fitted for ease of mounting in the wind tunnel nozzle. The mounting is shown in Figures 3(b) and 16.

4.4.2 Safety and Firing Procedures

Safety procedure was agreed prior to the trial with IMI Kidderminster and BAC Warton, and is recorded in full in the Trials Specification dated 12th September 1969. Since light outputs had to be measured, all firings were made in darkness, after normal working hours.

4.5 Observations on Measurement System Operation

4.5.1 Smoke Collection

The smoke measurement tube was positioned according to the best available information such that it was expected that all the flame, smoke, and sparks from the store would enter the tube. Preliminary experiments using dense red smoke from a pyrotechnic source showed that with the tube 8ft from the wind tunnel all the smoke went down the tube and the tube was filled.

When sets of flares were burnt later, smoke was less visible but all the sparks entered the tube in a similar way to the red smoke. (Figure 17).

When gas generators only were fired, smoke could be seen forming a narrow cone between the nozzle and the entrance of the tube.

Firings of motors on their own were also satisfactory, all the efflux entering the tube. During the boost phase, the end of the flame entered the tube, but not during the sustainer phase. The effect of the motor efflux when motors were burnt with flares was to produce a much more divergent flame, and smoke and sparks passed round the outside of the tube entrance during the boost phase. (Figure 18). All observers thought that this was a small percentage of the total.

Some sparks were seen at the exit after passing through 24.4m of the tube both with flare firings and motors. These sparks seemed to be in bursts and were particularly noticeable on the longer burning flares after 20 seconds of burning. The diagonal light path measurement system (see section 4.3.3(a)) failed to produce useful information during the testing of the fast burning

CONFIDENTIAL

SR 697 flares due to interference from sparks. Otherwise no serious difficulties were experienced.

4.5.2 Smoke assessment methods

a. Diagonal light path method

Results obtained from these four systems tended to fall into two sets. As can be seen in Table 3, the results from the two systems with the detectors facing the tube entrance disagreed with all other smoke results obtained on the trial. This is thought to be due to radiation from sources other than the lamps reaching the detector cells and results from these two systems were discounted. If this method were to be employed in the future it would be advisable to make all detectors face away from the source.

b. Sample tube method

In the earlier experiments in which rocket motors were fired, it was found that the windows of each end of the tube became coated with condensation during the boost phase. The condensation gradually cleared during the sustainer phase of motor burning. This problem was overcome by heating the windows using hot air blowers so that valid results were obtained on this trial. However, the air turbulence produced by this method of heating the windows can adversely affect the laser beam and should be avoided (Ref. 6). Further experiments will be carried out with windows heated by passing electrical current through very thin, essentially transparent, metal films.

c. Mirror method

Extra rubber padding was found to be essential to reduce noise on the record due to vibration. The two foot path length was sufficient when motors were fired. The system was not satisfactory in the first week due to vibrations and smoke deposits on the detector and laser windows and the mirrors. More deposition occurred on the lower surfaces and so one system was re-sited in a horizontal plane.

With type (vii) firings (4.4.1) smoke measurements were obtained for the boost and sustainer phases of the motor. However, due to the smoke deposits, the record was not reliable after motor burn-out. When motors were fired there was a large temperature gradient across the tube and this is thought to have caused more erratic movements of the laser beam.

Methods (a) and (c) were adversely affected by vibrations of the tube, particularly those systems in the fourth section. This was due to the end 'A' frame not being adequately anchored to the ground and was remedied by siting another 'A' frame nearer the tube exit.

Apart from the results from the two detectors of the diagonal light path system which faced the tube entrance, out of a total of 137 measurements only three results were discounted as they obviously disagreed with the majority of the results.

4.5.3 Radiometers

These functioned as expected, except that on one day both instruments gave readings which, on later analysis, were generally lower than on other occasions. This is thought to have been due to unusual atmospheric attenuation on this day (Oct. 22nd) when the recorded humidity was very high and general visibility was low (about $\frac{1}{2}$ mile).

4.5.4 TV Tracker

A usable record is not obtained from the TV tracker until the incident radiation is above a threshold level. It operates on different principles from the radiometers and is also sensitive to radiation in a wave-band nearer the infra-red. However, the tracker often gave unexpected results and was sometimes not triggered when radiation, measured by the adjacent radiometer, should have been sufficient to do so.

At the range of 190 metres, with the lens used, the TV tracker could discriminate between each of the 4 flares, and the AGC record relates to the (apparently) brightest of these sources.

On occasions, the tracker continued to give a record well above threshold after the burning time. This is thought to be due to the hot slag remaining in the flare cases being viewed in the absence of smoke. An example of this is shown in Figure 19, the record of run 4005. This never occurred in firings of 0.75 inch SR 699 or of SR 697 flares when the burnt cases were found to be completely clear inside.

4.6 Results

4.6.1 Firing Sequence

In Table 1 all firings are listed in chronological order together with data on the tunnel operation conditions, ambient weather data, firing pulse times, the observed burning times of items under test and, for flares only, the rates of burning computed from observed burning times and known charge lengths.

4.6.2 Basic data

The data from the instrumentation channels was analysed and the basic information so derived is given in Table 2. The basic data presented are:-

a. the flare outputs in watts per steradian per micron (minimum, maximum and average values) as measured by the radiometers and the particular values of flare outputs from both stations at selected, specified times. From the latter, percentage transmissions of light through the smoke tunnel length were computed and are given.

b. for all optical smoke measurement channels, the percentage transmission of light was taken at the specified times as in (a).

CONFIDENTIAL

c. for the selected times chosen for (a), the flare outputs, in watts per steradian per square metre per micron as recorded by the TV tracker were also computed and are presented.

d. the mean velocity of flow of the smoke-laden gases through the system during each experiment.

e. the optical path lengths for each smoke measurement channel.

All records were analysed. Some of the derived data were later eliminated from further consideration. (See Section 4.5). The light transmission data presented in Table 2 for each of the various measurement systems are not comparable, one system with another, as the optical path lengths are different.

4.6.3 Reduction of smoke measurement data to common path length

Using the method described in Appendix II, all the acceptable data on light attenuation by smoke were used to compute the percentage transmission which would have been recorded by each information channel had the optical path length been 7 metres instead of the various actual values. The values so computed are presented in Table 3.

4.6.4 Reduction of smoke measurement data to common path length and common flow velocity

The next step in data reduction was to correct the light transmission data from Table 3 for differences in rates of flow of the smoke-laden gases through the measurement system in the individual experiments. The common velocity chosen was 190 metres per second. The results are given in Table 4. This allows a direct comparison of the different systems for measurement. In Table 5 the averages of the light transmission values (given in Table 4) are presented for each type or combination of types of store burned. It is worth emphasising at this point that the attenuation factors given in Table 5 for the smoke produced under each condition are those which apply if all the smoke generated by the store(s) under test at simulated $M=1.17$ flight conditions, is restrained to be uniformly distributed within a cylinder 0.61 metres in diameter and of a length which is increasing at the rate of 190 metres per second.

4.6.5 Theoretical extrapolation of smoke measurement data to missile flight conditions

The BAC model of the smoke trail produced by the Rapier missile in flight assumes that the smoke is contained within a column which, if the missile trajectory is a straight line, has the following properties:-

- a. is symmetrical about the flight axis.
- b. is equal in radius to the radius of the missile at the surface of attachment to the missile.
- c. initially expands conically (half angle 3°) with increasing

distance away from the missile until it attains a radius of 0.6 metres.

d. once the radius of 0.6 metres is attained, the radius remains constant. These geometrical properties are based on studies of photographic records of missile firings.

It is further assumed that any elements of the column which are of unit length, measured along the cylindrical axis, contain the same amount of smoke, uniformly distributed. If the missile velocity is constant and the rate of generation of smoke is constant, then from the data in Table 5, the average light attenuation factors, in db per metre of optical path through the smoke, can be computed for any particular path through the smoke (See Appendix II). This has been done, assuming a missile velocity of 650 metres per second in a straight trajectory, for a line of sight starting at the centre of the missile base and angled at 1° to the line of flight. The attenuation factors, and percentage transmission figures over the complete smoke path length of 34.2 metres, are presented in Table 6. The 1° value was chosen because BAC reported no difficulties with TV tracking if the missile flight direction was more than 1° off the line of sight from tracker to missile. The velocity of 650 metres per second approximates to the maximum missile velocity (when the smoke trail is least dense). SR 697 figures are included in this table purely for comparison of the smoke characteristics with SR 699. However, SR 697 was not required for use under the above conditions when the missile is travelling at 650 m/second and the output is viewed through 34.2 metres of smoke at 1° off end-on. SR 697 was intended for use during the gather phase only and at the end of this phase the beacon would be viewed end-on.

The missile velocity is continuously varying throughout flight, accelerating during boost and sustainer phases of the motor firing and decelerating during coast phase after motor burn-out. During this phase, the flares and the gas charges continue to burn and finally the flares burn alone. The figures can be corrected for these different speeds. As the figures in Table 6 are calculated for a velocity of Mach 2 all the components will appear worse at slower speeds. This is shown in Figure 20.

4.6.7 Windspeed measurements

The results of the windspeed measurements are shown in Figure 21. In the second half of the tube, the variations in flow velocity between stations at different distances along the tube are small for any one given set of firing conditions. Average values were used in all calculations involving the flow velocity.

The observed flow velocities are considered to substantiate the prediction that pipe flow would have been established when the gases reached the mid point of the tube.

4.6.8 General observations on instrument recordings

a. As the electrical firing circuits were actuated slightly in advance of the start of tunnel operation, the windspeed round the flares was

> well below maximum when the igniters and primers were burning. These produced smoke which was not dispersed by high wind-speed and which formed a relatively dense cloud of smoke. The smoke measurement systems all recorded this section of high density smoke as it travelled down the tube. This transient high attenuation recorded at the beginning of each light transmission record was discounted in subsequent analysis.

b. The radiometers recorded a periodic fluctuation in the radiant output from the flares. This is discussed further in Section 4.7

c. A condensation cloud is produced in the wind tunnel at 'wind off' and this was recorded by the smoke measuring systems as it travelled down the smoke collection tube.

d. The accuracy of reading of the outputs from the smoke measurement channels is better than plus or minus 2 per cent of the full-scale readings. The spread of results given in Table 5 is considered to be real and due to variations between rounds.

4.7 Discussion of Results

4.7.1 Flare Performance

The results show that the flares generated a significant amount of smoke but that this was much less than that produced by the rocket motor. The 'standard' flare produced the least smoke. Variants on this flare, filled with SR 699, which had been shown to produce less smoke when fired under static conditions, proved to be measurably worse in this respect when fired under the Warton trial conditions. The four fast burning flares filled with SR 697, generated a very much greater amount of smoke (attenuation factor 0.53 dB/m (Warton condition) as compared with 0.07 dB/m for the four standard flares) which was not compensated for by the higher intrinsic light output over long path lengths through the smoke trail.

The average measured values for the smoke and radiation generated by sets of four flares when fired alone in the Warton wind tunnel are as follows:

Table A

4 Flares	Light output watts/steradian/ micron (1)(3)	Smoke attenuation factor dB/metre (2)(3)
SR 699/0.88"/Lantex	905	0.07
SR 699/0.88"/Kemetal	510	0.09
SR 699/0.75"/Kemetal	460	0.10
SR 697/0.88"/Lantex	2680	0.53

(1) Radiometers 19° off axis, spectral response as in Figure 10.
 (2) Normalised to 'Warton' condition - See section 4.6.4
 (3) Mach 1.17 windstream over store
 See Table 5

CONFIDENTIAL

The fast burning flare composition, SR 697 may not be completely suitable for use during the gather phase of the flight. The radiant output is much higher than that of SR 699 but the smoke produced when SR 697 burns is, comparatively, much denser. The velocity of the missile towards the end of gather is about 365 metres/second and under these conditions 36 metres of smoke from SR 697 or 275 metres of smoke from SR 699 will transmit 10% of the radiation. A less smoky, less bright flare may meet the requirements more fully. Consideration should be given to the minimum output required side-on for gathering and also to the minimum output necessary through the smoke when the missile is first gathered. A flare could then be designed to fulfil these requirements as far as possible. For example, consider a flare of 10 seconds/inch burning rate with output 1,000 watts/st/ μ m, at source. Viewed over a path through its smoke which has a transmission of 50% an apparent output of 500 watts/st/ μ m is measured. If more output is required side-on this may be achieved by speeding up the burning and theoretically 2,000 watts/st/ μ m will be obtained from a similar flare with a 5 sec./in. burning rate. However this means that twice the weight of material is burnt per second, producing twice the mass of smoke per second. Hence the transmission through the same path length of smoke will be 25% and the apparent output is still 500/watts/st/ μ m.

In practice speeding up the burning rate can give less output than expected from the simplified example above and more smoke than expected so that output through smoke is very low. Applying this to fast burning compositions, although higher output will be obtained side-on, it is possible that less output will be obtained through the smoke. Assuming the velocity of 365 metres/second at the end of the missile gather phase and an end-on view of the beacon, both compositions will have the same apparent brightness when viewed through about 19 metres of flare smoke trail. At any greater path length through the flare smoke, SR 699 will appear brighter than SR 697. The missile takes about 1/20 second to travel 19 metres.

When flares only were fired, the two radiometers recorded regular fluctuations, in phase with one another, and the number of these agreed with the number of filling increments used when pressing the flares. This was probably due to variations in density through each increment. Simultaneous electrical ignition of the four similarly pressed flares aggravated this effect. This variation was much reduced when flares were burnt with a rocket motor.

Very interesting results were obtained when motor, flares, and gas generator were fired together and these warrant close examination. A record of some of the measurements obtained on run 4020 is shown in Figure 22. The boost phase lasted about 2 seconds and, discounting the ignition phase, the record was best examined at about 1½ seconds. The on-axis radiometer measured much less radiation through the smoke than the radiometer at 19 degrees and the smoke measurement over 4.1 metres showed 50% transmission. During sustainer phase, at say 6 seconds, both radiometers measured more radiation. The percentage reduction due to smoke, between on-axis and off-axis measurement was much less than during the boost. This was confirmed by the smoke measurement. At completion of the sustainer burning, at 8.5 seconds, the on-axis radiometer registered a large decrease in signal for approximately ½ second. This is characteristic of motor burn-out.

CONFIDENTIAL

While flares, motor, and gas generator were burning together, the level of radiation registered on the off-axis radiometer was higher than when only flares and gas generator remained burning. However, when motors only were burnt, extremely low levels of radiation were recorded. Possibly this enhanced radiation was due to spreading of the flare flame by the motor efflux without excessive cooling so that the off-axis radiometer viewed a larger flame area. Meanwhile the on-axis radiometer was viewing through smoke produced by all these components and hence registered low output. The cine films of the burning confirm this.

After 15 seconds when the gas generator was extinguished and the flares continued to burn alone, a further immediate smoke reduction was registered over the 4.1 metres path length. The decrease in smoke was also shown on the on-axis radiometer record.

4.7.2 Correlation of Free Flight Measurements with Extrapolated Warton Trial Data

There is no available data on the effects of missile smoke on the visibility of the tracking flare from firings of Rapier missiles. The tracking flare being used on Seawolf missiles is essentially identical to that used on Rapier, and radiometric measurements have been made of Seawolf flares, in flight, on Toc H rockets. One set of measurements (Reference 7) albeit using two radiometers which had spectral responses somewhat different from those used in the Warton Rapier trial and different from each other, gave peak measured outputs from 4 flares, of 800 watts/st/micron. These readings all occurred at times after motor burn-out when the missile was travelling at or about Mach 1 and with the missile direction at 3° or more to the line of sight when it may reasonably be assumed that there was little or no smoke obscuration. Visibility was excellent at the time of the firings (estimated 50 miles) so that discounting atmospheric attenuation would then not give rise to an error in excess of 20% in the radiometric results. The actual readings, 10 in number, ranged from 740 to 920 watts/steradian/micron. The corresponding Warton figures were 850 and 960 watts/steradian/micron from two experiments. This is considered very fair agreement.

Reference 7 makes no mention of loss of visibility of the flares. The minimum recorded flare output averaged 340 watts/steradian/micron (10 recorded values ranging from 320 to 380 watts/steradian/micron). These low values were all recorded at about 6 seconds after missile launch at a time when the missile was nominally travelling along the line of sight from the observation point. Motor burn-out occurred at 3.8 seconds and no measurements were taken before 4 seconds. The 340 watts/steradian/micron figure may be taken to be the observed flare output under conditions of maximum obscuration by flare smoke in these particular experiments. Unfortunately the length of that part of the line of sight which passed through the smoke was not known and it is not possible to make any comparison between observed smoke attenuation and the Warton trial results extrapolated to flight conditions.

The Warton results were the basic data for calculation to flight conditions using the mathematical model for the smoke trail as described previously (para. 4.6.5).

The assumptions made in using the model are:-

a. that each smoke source produces smoke at a constant mass rate which is independent of the environmental conditions surrounding the missile. This has not been experimentally verified. The best that can be said is that the Warton trials show that, for a given environmental condition, the rate is reasonably constant throughout the burning time of the component.

b. that the smoke in any cross-sectional element of the smoke trail is evenly distributed across that element. This also has not been verified but would seem a reasonable assumption to apply in the turbulent conditions which occur some distance from the motor exhaust when the motor is burning. When the motor is not burning good mixing of smoke with entrained air would be expected very close to the tail of the missile.

c. that Beer-Lambert's Law applies, i.e. the attenuation of light is directly proportional to the mass of smoke (of a given kind) in the sight path. This has been verified (Reference 8) for smoke produced by propellants burned in rocket motors.

A significant deficiency in the model is the failure to explain the BAC finding of a relatively sharp cut-off in the ability of the tracker to follow the missile as the line of sight from the tracker approached 1° to the line of missile flight. At an angle of 2° the calculated transmission along the line of sight is 42 per cent during the sustainer phase. Certainly for angles up to 3° no sudden change in transmission would be expected as, until this angle is exceeded, the line of sight must pass through the relatively dense diverging cone of smoke immediately behind the missile.

More recent work on other missile systems has indicated that the smoke trail may change in shape during the various stages of flight, particularly after motor burn-out. Films of other missiles show a much smaller angle of divergence when flares only were burning and this seems plausible, as the combustion products would expand as a direct result of their excess pressure above local atmospheric pressure. Thus the final diameter of the cylindrical portion of the smoke trail could be expected to be considerably smaller after motor burn-out than during the motor firing.

It is thought that the Rapier smoke model may be too simple and that a more elaborate model which varied during the different stages of the missile flight might be more appropriate. An extensive study of the films of Rapier smoke trails formed during flight might provide an improved model.

4.8 Conclusions

4.8.1 Smoke Measurement

a. The smoke emitted by various combinations of components of the Rapier missile has been quantitatively assessed in terms of attenuation of visible radiation. The data obtained are summarised below:

/Table B

Table B

Missile Condition	Smoke Attenuation Factor dB/metre (1)
(a) Boost Phase - flares motor and gas generator burning	1.34
(b) Sustainer Phase - flares motor and gas generator burning	0.49
(c) Coast Phase - flares and gas generator burning	0.16
(d) Coast Phase - flares only burning	0.06
(1) Calculated from Warton trial results assuming smoke velocity of 190 metres/second and a path length of 7 metres. Complete data given in Table 5	

b. The smoke emission of individual components has been quantitatively measured. Within the accuracy of measurement, the effect of two or more components is equal to the sum of the individual component effects. (See Table C below).

Table C

Components	Smoke Attenuation Factor dB/metre (1)
(a) Troy Motor - boost	1.43
(b) " " - sustainer	0.37
(c) 4 x SR 699/0.88"/Lantex Flares	0.07
(d) Gas Generator Mechanite 14	0.10
(e) (b + c + d) Motor (sustainer) + Flares + GG	0.54
(f) Sustainer Phase - Flares motor and gas generator burning	0.49
(1) Calculated Warton trial results assuming a smoke velocity of 190 metres/second and a path length of 7 metres. Complete data given in Table 5	

CONFIDENTIAL

o. The Troy rocket motor is the major source of smoke.

d. The BAC smoke model represents a reasonable first approximation of the true situation.

4.8.2 Flare Performance

a. Of three flares tested, all filled with composition SR 699, the 'standard' Rapier flare was clearly superior - highest light output with least smoke.

b. Composition SR 697 was intended to increase the radiant output during the gather phase of missile flight. In producing this high output it was found to be very smoky so that it is possible to obtain less 'apparent' output, end-on through the smoke. Although it could aid gathering of the missile it is likely to increase the possibility of losing the missile at the end of gather and is, therefore, considered unsuitable for use with Rapier.

o. The radiant output of the four SR 699 'standard' flares, under missile flight conditions as simulated by the Warton trial is 905 watts/steradian/micron (as measured by the radiometers described) with no smoke in the sight line and no other missile components burning.

d. There is a significant increase in the light output from the Rapier tracking flare if the flare is fired in close proximity to the exhaust from the burning Troy rocket motor.

4.9 Recommendations

a. Any effort directed towards reduction of total smoke emission from the missile should be concentrated on the Troy rocket motor.

b. The SR 699/0.88"/Lantex flare should be retained at present for the Rapier missile and no further effort should be deployed in attempting to improve flares based on this composition.

o. Further work is needed to refine the BAC model of the smoke trail generated by a missile.

d. In any future work on assessment of flare performance using the Warton facility (or any similar facility) it is essential that atmospheric attenuation along the lines of sight of the radiometers should be measured. It would also be useful if the missile tracker were deployed alongside the radiometer to correlate tracker signal with the radiometer reading.

e. All future missile beacons which consist of multiple flares should have staggered increments in each set of flares to reduce fluctuations in radiant output.

5. DISCUSSION ON SMOKE MEASUREMENT

5.1 Dynamic versus Static Firings

In the Rapier trial two 'improved' flares were tested - flares which, under static conditions, had been shown to produce less smoke than the standard Rapier flare. Both were shown to produce more smoke under dynamic conditions. No numerical data are available on the smoke generation by the 'standard' and 'modified' Swingfire motors. Subjective observation was that the modified version which gave more smoke on static test produced less smoke in free flight.

The outstanding value of the Warton/Rapier trial is the unequivocal conclusion that, if valid information on the amount of smoke generated by missile components is to be obtained, the components must be fired under conditions which reasonably simulate the free flight missile situation. The effect of motion relative to the ambient atmosphere is a factor of considerable importance.

5.2 Smoke Measurement Equipment

The experimental technique described in Section 4 gave reproducible results which are generally consistent with the very limited information available from free-flight firings. When a Troy motor was fired together with flares and the gas generator, then during the boost phase only, a small part of the total efflux did not enter the tube. The only significant deficiency which should be rectified in advance of further trials, if measurements of boost motors are required, is extension of the smoke collection tube further forward towards the end of the wind tunnel. Of the optical techniques used to measure the properties of the smoke, the sample tube method (see Section 4.3.3(b)) is suggested as the most suitable, subject to minor improvements as described in Section 4.5.2(b). A second method should be deployed as a back-up system. This could be provided by radiometers if flare output measurements are being made. However, these measurements are susceptible to atmospheric attenuation problems and open to some doubt, as the smoke entering the collection tube does not become uniformly mixed until some distance down the tube and smoke modification may be occurring in the regions close to the rocket motor, e.g. condensation of water vapour. A second optical system is preferable.

5.3 Extrapolation from Dynamic Trial Results to Free Flight Conditions

It must be noted that, in the recommended approach to obtaining valid smoke data, although simulated flight conditions must be produced in the region of the smoke generators, the smoke is measured while under conditions which do not simulate flight conditions. Numerical manipulation of the data will always be necessary to obtain information on the free flight smoke trail, and a model of the free flight smoke trail is essential. Implicit in the method is the assumption that the nature of the smoke does not change significantly with time once it is formed. This is probably the greatest weakness. Condensable materials are significant contributors to missile smoke trails and, at present, insufficient is known as to the rate at

CONFIDENTIAL

which missile exhaust vapours condense to form optically significant particles and how this condensation is affected by ambient relative humidity, temperature, and concentration of condensable material. A great deal remains unknown. However, the work reported here represents a significant advance towards resolution of this problem.

6. CONCLUSIONS

6.1 If useful measurements are to be made on the smoke generated by missile components, those components should be fired under simulated operational conditions. However, it is important to make measurements on the individual components of the missile system in order to assess the contribution to the problem from each of the components and also to verify any improvements made to a particular component.

6.2 A technique for the measurement of smoke produced by missile components (fired under simulated flight conditions) has been evolved and shown to function satisfactorily.

7. RECOMMENDATIONS

7.1 For the assessment of smoke generated by missile components the equipment of the type devised and used at BAC, Warton for tests on the Rapier missile is desirable and such a facility should be maintained in readiness for missile testing. The Warton-Rapier trial indicated various improvements which should be made to the facility used on that particular trial (See Section 5.2).

7.2 Further work is needed on the study of missile smoke trails (See Section 5.3) and in particular on the shape of the smoke trail after the motor has finished burning.

8. ACKNOWLEDGEMENTS

The authors wish to thank everyone attending the trial (See App.III) for their help and co-operation. In particular they fully appreciate the large part played by Mr. P. Wise and Mr. D.-Green of the British Aircraft Corporation in the planning of the trial.

CONFIDENTIAL

9. BIBLIOGRAPHY

1. A Mathematical Model for Rocket Exhaust Smoke Plumes, F R Wallis
Technical Report S.R.S. 69/21. Summerfield Research Station
IMI Ltd, Kidderminster
2. High-speed Wind Tunnels, English Electric Aviation Ltd
BAC Publication No. BAC.4
3. Users Guide to the Guided Weapons Division 18-inch Blow-down Wind
Tunnel Operating at Mach Numbers 1.5 to 6. C G Plane.
Wind Tunnel Note No.4, English Electric Aviation Ltd
4. BAC Report ST. 4359, Prediction of Smoke Plume Diffusion in
a pipe;
5. BAC Report No. SY. 5244, Pyrotechnic Flare Measurement
6. Wireless World Aug. '69 'Laser application in electronics
7. BAC Report No. ST. 3985 Seawolf Flare Trials
8. Martin, J. K. and Viles, J. M.
Smoke measurement facility
Rohm and Haas Company, Redstone Research Laboratories, Huntsville,
Alabama 35807
Technical Report S - 159 March 1968
(US Army Missile Command. Contract DAA H01-67-C-0655)

DESCRIPTION OF RARDE/E3 SMOKE-MEASURING SYSTEM

The system was required to give reproducible smoke attenuation results from a given type of flare, burnt statically, and to cope with a wide variation in smoke density. A further requirement was that the record obtained should be free from 'noise' and erratic fluctuations common to this type of measurement. Also a method was needed whereby any flare-smoke improvement could be assessed for missile flight conditions, so that realistic comparisons could be drawn between test flares. (See Appendix II). Therefore it was considered essential to constrain all the smoke produced by the flare into a closely controlled column of uniform density and known velocity.

The apparatus evolved to satisfy these requirements is known as the RARDE Smoke Chimney and consists of an 0.3m diameter 1.83m long cylinder, mounted vertically and provided with a conical entrance base so that all the smoke from a vertically burning flare is gathered into the standard column by natural convection. The flare is burnt centrally 3.05m below the cylindrical base, this distance being sufficient to avoid interference from sparks. Three attenuation measurements are made using Tungsten lamps and CdS detectors set diametrically across the cylinder at distances 0.46m, 0.92m and 1.37m. up the cylinder, the detectors being used on a linear response to intensity range. The lamps and detectors are set back in 0.05m. diameter tubes at right angles to the cylinder, and a 'Permatrace' diffusing screen is used to enlarge the area of the light beam so that small local variations in smoke density are not recorded. (It has been shown that the dead space in front of lamp and detector does not collect smoke and the light path through the smoke is 0.3m). Three attenuation measurements were provided so that uniformity of smoke density could be assessed by comparing the three results. Horizontally across the top of the 1.83m. cylinder is mounted a four-bladed fan on nylon bearings which interrupts a lamp-detector path so that the velocity of the smoke column can be measured. This fan has been calibrated using an anemometer. All measurements are made continuously through the burning of the flare, and it is found that the interval between the first drop in lamp intensity due to attenuation and the regaining of maximum signal agrees to within 1 second of the total burning time, i.e. the smoke measurements at any instant refer to the smoke produced at an instant.

Gas charges have been measured using the same apparatus but mounting the gas charges 1.22m. above the hearth floor. The charges were adapted to a single exit nozzle giving a vertical jet of smoke with the single nozzle vertical.

This system gives excellent reproducibility with flares and gas charges, and it has been possible to make convincing comparisons between flares, and also to compare flares with gas charges. The records show a minimum number of erratic fluctuations, good agreement is obtained between the three lamp-detector measurements for each run, and the level of attenuation for flares ranges from 70% to 50% which minimises variations from round to round due to base-line and maximum-signal setting errors.

CONFIDENTIAL

A series of flares burnt in this apparatus gave attenuation across an 0.3m. path, averaged from measurements in close agreement, and the smoke velocity. Calculation over a definite path length of the B.A.C. missile smoke model gives figures of attenuation which are directly comparable, and indicates the degree of improvement likely to be obtained from less smoky flares mounted on the missile.

CONFIDENTIAL

OBSCURATION BY SMOKE FROM A BURNING FLARE

1. Assumptions

- 1.1 The flare gives a mass of smoke M_1 in time t_1
- 1.2 The rate of smoke output is constant, whatever the conditions of air flow around the flare.
- 1.3 Every cross-section of a given smoke column contains the same quantity of smoke uniformly distributed across it, hence the mass per unit length of cross-section varies inversely with the area of cross-section.
- 1.4 Beer-Lambert's law applies to smokes and hence the attenuation of the light is proportional to the mass of smoke in the sight path.

2. Measurement under test conditions

Velocity of smoke stream averaged across the tube = m metres/sec.
 Therefore total length of smoke stream from flare = $m_1 t_1$ metres
 Therefore total volume of smoke = $m_1 t_1 \pi R^2$

Where R is the radius of the smoke column
 Therefore for any sight path of length L and unit cross-sectional area which lies entirely through the smoke, mass of smoke in path = $M_1 \frac{L}{m_1 t_1 \pi R^2}$

Therefore attenuation = $10 \log \frac{1}{B} \text{ dB} = \frac{KM_1 L}{m_1 t_1 \pi R^2} \dots \dots \dots (1)$

Where B is the fraction of light received from a source when viewed through the path of length L , and K is a constant.

3. Missile Viewing

3.1 B.A.C. have proposed a model of the smoke from a missile. The smoke column is assumed to start with radius r_1 , the radius of the missile and expand in conical form with half angle 3° to radius r_2 , then maintaining a uniform cylindrical form. By studying film of flights, r_2 is taken as 0.6 metres.

3.2 The mass of smoke M_1 now occupies $m_2 t_1$ metres where m_2 is the velocity of the missile in metres/sec.

3.3 If L_f is the length of the conical frustum, the mass in that frustum

$$M_f = \frac{L_f}{m_2 t_1} M_1$$

If $\Delta M_f =$ mass per unit length of frustum = $\frac{M_f}{L_f}$

Mass per unit volume = $\frac{\Delta M_f}{\pi r^2}$ where r is radius of cross-section

and mass per element of length dL = $\frac{\Delta M_f}{\pi r^2} dL$

But r = L tan θ where θ is the half angle (3°) of the cone of which the frustum is part

Therefore mass per unit area cross-section per length dL = $\frac{\Delta M_f}{\pi \tan^2 \theta L^2} dL$

and mass per unit area cross-section over whole length of frustum of cone =

$$= \int_{L_1}^{L_2} \frac{\Delta M_f}{\pi \tan^2 \theta L^2} dL$$

$$= \left[\frac{-\Delta M_f}{\pi \tan^2 \theta L} \right]_{L_1}^{L_2}$$

where L_1 and L_2 are the lengths of the cone corresponding with the radii r_1 and r_2 of the frustum

Therefore mass per unit area over whole length = $\frac{\Delta M_f}{\pi \tan^2 \theta} \left[\frac{L_2 - L_1}{L_1 L_2} \right]$

But $L_2 - L_1 = L_f$ and $L_1 L_2 \tan^2 \theta = r_1 r_2$

Therefore mass per unit area over whole length = $\frac{\Delta M_f L_f}{\pi r_1 r_2} = \frac{M_f}{\pi r_1 r_2}$

$$= \frac{L_f M_1}{m_2 t_1 \pi r_1 r_2}$$

3.4 Over a given length of the cylindrical column L_3 , the mass of smoke per unit area cross-section is: $\frac{M_1 L_3}{m_2 t_1} \frac{1}{\pi r_2^2}$

3.5 Therefore when viewing the flare when the sight line passes through the smoke:

Total mass in sight line is:

$$\frac{M_1 L_f}{\pi r_1 r_2 m_2 t_1} + \frac{M_1 L_3}{m_2 t_1} \frac{1}{\pi r_2^2}$$

$$= \frac{M_1}{m_2 t_1 \pi r_2} \left[\frac{L_f}{r_1} + \frac{L_3}{r_2} \right]$$

Therefore attenuation = $10 \log \frac{1}{C} \text{ dB} = K \frac{M_1}{m_2 t_1 \pi r_2} \left[\frac{L_f}{r_1} + \frac{L_3}{r_2} \right] \dots \dots \dots (2)$

where C is the fraction of light received.

4. Application of RARDE Smoke Chimney results to Warton trial

Suppose a flare burnt in the RARDE chimney gives the following results:

Velocity of smoke $m_1 = 6$ metres/seo.

Percentage of light received through smoke = 20% therefore $B = 0.2$
 Path length $L = 2R = 0.3$ metres

Then from equation (1)

$$K = \frac{m_1 t_1 \pi R^2}{M_1 L} \quad 10 \log \frac{1}{B}$$

$$= \frac{6 \pi t_1 (0.15)^2}{M_1 \times 0.3} \quad 10 \log \frac{1}{0.2}$$

If the same type of flare is burnt in the Warton tube

$$\text{Attenuation} = 10 \log \frac{1}{D_1} = \frac{K M_1 L_w}{m_w t_1 \pi R_w^2}$$

Where L_w is path length over which the measurement was taken, m_w the velocity of the smoke, averaged over that path and R_w the radius of the tube, and D_1 is the fraction of light received.

$$10 \log \frac{1}{D_1} = \frac{6 \pi t_1 (0.15)^2}{M_1 \cdot 0.3} \cdot \frac{M_1 L_w}{m_w t_1 \pi R_w^2} \quad 10 \log \frac{1}{0.2}$$

$$= \frac{6 (0.15)^2}{0.3} \cdot \frac{L_w}{m_w R_w^2} \quad 10 \log 5$$

But $R_w = 0.3$ metres and we can assume $m_w = 344$ m/seo.

Then over a path length of 8 feet = 2.44 metres

$$10 \log \frac{1}{D_1} = \frac{6 (0.15)^2}{0.3} \cdot \frac{2.44}{344 (0.3)^2} \quad 10 \log 5$$

$$\log \frac{1}{D_1} = 0.0248$$

$$\frac{1}{D_1} = 1.059 \quad D_1 = 0.945$$

Therefore obscuration due to 1 flare = 5.5%

Thus if 4 flares are burnt together in the Warton tube

$$10 \log \frac{1}{D_4} = 4 \times 6 \frac{(0.15)^2}{0.3} \frac{2.44}{3.44} (0.3)^2 \quad 10 \log 5$$

$$\log \frac{1}{D_4} = 0.0992$$

$$1/D_4 = 1.256 \quad D_4 = 0.795$$

Therefore obscuration due to 4 flares = 20.5%

Similar calculations were used to forecast the transmission to be expected for all types of flares in the Warton tube when burnt in sets of 4. Also the transmission to be expected from a gas charge was calculated. Obviously these calculations were only a guide, being based on the assumption that burning under static conditions is similar to burning in a windstream.

These predicted transmissions are given below:-

Transmission in RARDE ohimney from 1 flare	Transmission in RARDE ohimney from 1 gas generator 10% (after 8 secs.)				
	50%	40%	30%	20%	
Path length at Warton					
0.61 m.	97.5%	97%	96%	95.5%	97%
1.22 m.	95%	93.5%	92%	89%	94%
2.44 m.	90.5%	88%	84%	79.5%	89%
3.66 m.	86.5%	82.5%	77.5%	71%	83.5%
4.57 m.	83%	78.5%	72.5%	65%	80%
24.4 m.	37.5%	27%	18%	10%	30%

Measured smoke velocity through the Warton tube was 190 metres/secs. and not 344 metres/sec. as assumed for these calculations. This accounts for some of the differences between the predicted results and results actually obtained but the calculated transmissions served as a useful guide.

5. Motor Smoke estimation from static data

Little is known about the attenuating properties of motor smoke at present and it was difficult to estimate accurately values which were to be expected at Warton.

Some static measurements made by I.M.I. at their Summerfield Research Station indicated values of approximately 55% obscuration from motors and an extra 5% obscuration from a set of 4 flares.

$$\text{Therefore } \frac{\text{attenuation due to flare}}{\text{attenuation due to motor}} = \frac{\log \frac{1}{0.95}}{\log \frac{1}{2.22}} = \frac{\log 1.052}{\log 2.22} = 0.0635$$

$$\log \frac{1}{0.45}$$

Thus if 10% obscuration were to be expected from the present flare at Warton (as was possible over a short path length, see 4 above)

$$\frac{\text{Attenuation due to flare at Warton}}{\text{Attenuation due to motor at Warton}} = \text{Log} \frac{1}{0.9} = 0.0635$$

$$\text{Log} \frac{1}{M}$$

$$\text{Log} \frac{1}{M} = \text{Log} \frac{1.111}{0.0635} = \frac{0.0453}{0.0635} = 0.713$$

Therefore obscuration expected from motor at Warton over short path length = 80%

6. Application of Warton tube results to missile flight

The scant data available suggests that the effect of an air stream on the burning of a flare is increasing most rapidly between Mach 0 and 0.3. From Mach 0.3 to 2 the output from the flare is affected less noticeably. Thus an extrapolation of the data obtained from the Warton tube trial to the conditions of missile flight should be feasible. As the flares are to be mounted on either real motors and tail cones or dummy missiles and simulated tail cones in the Warton wind-tunnel the data may be meaningfully applied to in-flight conditions.

From eq (1)

$$10 \text{ Log} \frac{1}{D_4} = \frac{K M_1 L}{m_1 t_1 \pi R^2} \dots\dots\dots (1)$$

$$\text{Thus } K = \frac{m_1 t_1 \pi R^2}{M_1 L} \quad 10 \text{ Log} \frac{1}{D_4}$$

Values of m_1 , R , L and D_4 may be supplied from the Warton data

From eq (2)

Attenuation during missile flight

$$10 \text{ Log} \frac{1}{C} = K \frac{M_1}{m_2 t_1 \pi r_2} \left[\frac{L_f}{r_1} + \frac{L_3}{r_2} \right] \dots\dots\dots (2)$$

$$\text{Thus } 10 \text{ Log} \frac{1}{C} = \frac{m_1 t_1 \pi R^2}{M_1 L} \frac{M_1}{m_2 t_1 \pi r_2} \left[\frac{L_f}{r_1} + \frac{L}{r_2} \right] 10 \text{ Log} \frac{1}{D_4}$$

- Let angle between flight path and sight line be 1°
- r_1 is radius of missile tail cone = 0.063 metres
- r_2 is radius of smoke column of B.A.C. model = 0.6 metres
- m_2 is speed of missile, say 650 metres/sec.
- L_f = 10.24 metres
- L_3 = 24 metres

CONFIDENTIAL

$$\begin{aligned}
 10 \text{ Log } \frac{1}{C} &= \frac{m_1 (0.3)^2}{L \ 650 \times 0.6} \left[\frac{10.24}{0.063} + \frac{24}{0.6} \right] 10 \text{ Log } \frac{1}{D_4} \\
 \text{Log } \frac{1}{C} &= \frac{m_1}{L} 2.307 \times 10^{-4} [162.6 + 40] \text{ Log } \frac{1}{D_4} \\
 &= \frac{m_1}{L} 0.0467 \text{ Log } \frac{1}{D_4}
 \end{aligned}$$

Thus the fraction of the output from the flare seen through the smoke, C, can be found if the Warton value of m_1 , L and D_4 are substituted. A similar calculation can be used for any angle of sight line to missile flight path.

CONFIDENTIAL

APPENDIX III

LIST OF PERSONNEL ATTENDING THE TRIAL

Lt. Col. J. L. H. Tudor - RRE Malvern - Chairman Smoke Working Party
Mr. J. S. Bickerdike - RRE Malvern - Observer
Major G. D. Carter - GW(M)4 - Observer
Mr. B. Johnson - IMI Kidderminster - Motor adviser
Mr. J. Dewar - ICI Ardeer - Gas Generator adviser
Mr. C. G. Plane - BAC, Warton GW Wind Tunnel
Mr. J. Smith - BAC, Warton GW Tunnel operator
Mr. A. Archdale - BAC, Warton
Mr. G. Haynes - BAC, Warton
Mr. P. Hall - BAC, Warton
Mr. P. Wise - BAC, Stevenage, Systems Division
Mr. D. Green - BAC, Stevenage, Systems Division
Mr. R. Rotheroe - BAC, Stevenage, Systems Division
Mr. G. Callow - BAC, Stevenage, Systems Division
Mr. D. Izod - RARDE, Langhurst
Mr. N. Williams - RARDE, Langhurst
Mr. R. Awcock - RARDE, Langhurst
Mr. P. Kilby - RARDE, Langhurst
Mrs. M. Budgen - RARDE, Langhurst
Mrs. S. Buckle - RARDE, Langhurst
Mr. J. Gilmore - RARDE, Langhurst

RECORD OF FIRINGS

Run No.	Details of devices fired (Electrical Ignition)	Date Fired	Ambient Conditions (1)				Air-flow conditions X (Z) or Y	Time of firing pulse to each device (wind on at zero sec.)	Time of Burning for each device (secs.)	Rate of Burning of Flares (secs/in.)	Remarks
			Wind speed m.p.h.	Wind Director	Temp. °C	R.H. %					
4,000	4 Flares SR.699 0.88" I.D. Lantex Liner	15.10.69.	10-12	S	12.5	85	X			No air-flow by error	
4,002	4 Flares SR.699 0.88" I.D. Lantex Liner	16.10.69.	8-9	S	15	76	X				
4,003	4 Flares SR.699 0.88" I.D. Kemetal Liner	16.10.69.	8-9	S	14	76	X	-1.2	35	12.5	
4,004	4 Flares SR.699 0.75" I.D. Kemetal Liner	16.10.69.	8-9	S	14	76	X	-1.05	27.5	9.8	
4,005	4 Flares SR.699 0.88" I.D. Lantex Liner	16.10.69.	6-7	S	13	75	X	-1.1	25	8.9	
4,006	4 Flares SR.699 0.88" I.D. Kemetal Liner	16.10.69.	6-7	S	13	75	X	-1.15			
4,007	4 Flares SR.699 0.75" I.D. Kemetal Liner	16.10.69.	6-7	S	12.5	75	X	-0.7	28.5	10.2	
4,010	Troy Motor Serial No.5080 ex I.M.I. Evaluation	17.10.69.	NIL	-	15	72	Y	-0.25			
4,011	Gas Generator Mechanite 14	17.10.69.	NIL	-	15	72	Y	-0.25	8.7		
4,012	Troy Motor Serial No.5097 ex I.M.I. Evaluation	20.10.69.	NIL	-	13	85	Y	-0.3			
4,013	Gas Generator Mechanite 14	20.10.69.	NIL	-	12	85	Y	-0.3	15 (approx)		
4,014	Gas Generator Mechanite 14	20.10.69.	NIL	-	12	85	Y	-0.15	16.8		
4,016	Troy Motor Serial No.5103 ex Troop Trials	21.10.69.	NIL	-	13	85	Y	-0.25	7.5		
4,017	Troy Motor Serial No.5101 ex Bishopston + 4 Flares SR.699 0.88" I.D. Lantex Liner + Gas Generator	21.10.69.	3	-	12	85	Y	+0.2 -0.2	23	8.2	
								-0.2			Gas Generator did not fire

Run No.	Details of devices fired (Electrical Ignition)	Date Fired	Ambient Conditions (1)			Air-flow conditions X(2) or Y	Time of firing pulse to each device (wind on at zero sec.)	Time of Burning for each device (secs.)	Rate of Burning of Flares (secs/in.)	Remarks
			Wind speed m.p.h.	Wind Direction	Temp. °C					
4,018	Troy Motor Serial No.5158 ex Bishopston + 4 Flares SR.699 0.88" I.D. Lantex Liner + Gas Generator	22.10.69.	2-3	E	13.5	90	+0.25 -0.15			
4,020	Troy Motor Serial No.5151 ex Bishopston + 4 Flares SR.699 0.88" I.D. Lantex Liner + Gas Generator	22.10.69.	5	E	12	85	+0.2 -0.2			
4,022	Troy Motor Serial No.5033 ex I.M.I. Evaluation	22.10.69.	5	E	12	85	-0.2	8.8		Wind for 5 seconds only
4,023	Troy Motor Serial No.5160 ex Bishopston + 4 Flares SR.699 0.88" I.D. Lantex Liner + Gas Generator	22.10.69.	5-6	E	11	95	+0.2 -0.2	23	8.2	
4,024	4 Flares SR.699 0.75" I.D. Kemetal Liner	23.10.69.	12-14	SW	13	84	-0.2 -0.6	27.4	9.8	
4,025	4 Flares SR.699 0.88" I.D. Kemetal Liner	23.10.69.	12-14	SW	13	84	-0.6	33.6	12.0	
4,026	4 Flares SR.699 0.88" I.D. Lantex Liner	23.10.69.	16-20.	SW	12	70	-0.65	23.8	8.5	
4,027	4 Flares SR.697 0.88" I.D. Lantex Liner	23.10.69.	16-20	SW	12	70	-0.65	12	2.1	
4,028	4 Flares SR.697 0.88" I.D. Lantex Liner	23.10.69.	16-25 Gusty	SW	12	74	-0.65	11.5	2.0	
4,029	4 Flares SR.697 0.88" I.D. Lantex Liner	23.10.69.	16-25 Gusty	SW	12	74	-0.6	12.5	2.1	

(1) Ambient conditions were measured at the T.V. tracker position and may have varied near the wind tunnel building.

(2) Condition X involved a different body, for mounting the device being fired, from Condition Y. Measurement showed that air-flow over the bodies was similar. (see para.4.3.2.)

SMOKE MEASUREMENTS CORRECTED TO 7 METRES PATH LENGTH

Run No.	Details of devices fired	Mean smoke velocity in tube m/sec.	Sample tube system (laser) Transmission %	Diagonal light path method			Mirror method (Laser) Transmission % (1)		Ratio of Radiometer Signals Transmission %
				Detector facing Upstream * 1	Detector facing Downstream 2	Detector facing 3	Station 1	Station 3	
4,000	4 flares, 0.88" I.D. Lantex Liner SR.699	190	96	51	87				
4,005	-do-	190	90	31	95	92			91
4,026	-do-	190	85		82	91	88	88	84.5
4,003	4 flares 0.88" I.D. Kemetal Liner SR.699	190	85	35	35*				
4,006	-do-	190	90	42	89.5	82			82.5
4,025	-do-	190	80	57	92	89.5	88	80	85
4,004	4 flares 0.75" I.D. Kemetal Liner SR.699	190	90 80	36.5	87	77.5			
4,007	-do-	190	90	32.5	95	75			88.5
4,024	-do-	190	70		87	87	84.5	50 *	85.5
4,027	4 flares 0.88" I.D. Lantex Liner SR.697	190	45				41.5	36.5	52
4,028	-do-	190	40				38.5	34	49
4,029	-do-	190	45				44	34	49
4,011	Gas Generator Mechanite 14	188	89	51	89.5				
4,013	-do-	188	88		75	89.5			
4,014	-do-	188	90		77.5	59 *			

(1) Station 2 was inoperative for these runs

* Inconsistent results (see para.4.5.2.)

TABLE 3 (CONTD)

Run No.	Details of devices used	Mean Smoke velocity in tube m/sec.	Sample tube system (Laser) Transmission %	Diagonal light path method			Mirror method (Laser)			Ratio of Radiometer signals Transmission %	Firing Phase
				Detector facing Upstream *	Detector facing Downstream	Transmission %	Station 1	Station 2	Station 3		
4,010	Troy Motor Serial No.5080 ex I.M.I. Evaluation	232 232		17 39.5	71 80	27.5 59	32.5 67	1	2	3	Boost Sustain
4,012	Troy Motor Serial No.5097 ex I.M.I. Evaluation	232 232		52 27.5	19 28.5	3	4 44	18 53		11.5 44	Boost Sustain
4,016	Troy Motor Serial No.5103 ex Troop Trials	232 232	21	15 32.5	10 26	12 84.5	5 65		11.5 75	6 75	Boost Sustain
4,022	Troy Motor Serial No.5033 ex I.M.I. Evaluation	232 232	31 61	14 31	10 22	23 44	10 59	11.5		3.5	Boost Sustain
4,017	Troy Motor Serial No.5161 ex Bishoppton + 4 x SR.699 flares, 0.88" Lantex Liner. Gas generator did not fire	241 241	25.7 61 83.5	12.5 31	9 24	10 87	7 63		7.5 63	1 36.5	Boost Sustain Flares
4,018	Troy Motor Serial No.5158 ex Bishoppton + 4 x SR.699 flares, 0.88" Lantex Liner + Gas generator	241 241	31	11	9	2	6.5	18 63		7 50	Boost Sustain Flares + GG Flares
4,020	Troy Motor Serial No.5151 ex Bishoppton + 4 x SR.699 flares, 0.88" Lantex Liner, + Gas generator	241 241	23.5 54 76 89					7 47		1 50	Boost Sustain Flares + GG Flares
4,023	Troy Motor Serial No.5160, ex Bishoppton + 4 x SR.699 flares, 0.88" Lantex Liner, + Gas Generator	241 241	31 61 76 92	12 28.5	9.5 17	25 55	6 57	15.5		1	Boost Sustain Flares + GG Flares

* Inconsistent results

RUNS INVOLVING MOTORS
 SMOKE MEASUREMENTS CORRECTED TO 7 METRES PATH LENGTH AND
 190 m/sec. SMOKE VELOCITY

Run No.	Details of devices fired	System tube system (Laser) Transmission %	Diagonal light path method				Mirror method			Ratio of Radiometer signals Transmission %	Firing Phase
			Detector facing Upstream	Detector facing Downstream	Transmission %	Station 1	Station 2	Station 3			
4,010	Troy Motor Serial No.5080, ex I.M.I. Evaluation		11.5 32	21 52.5	25.5 61.5						Boost Sustain
4,012	Troy Motor Serial No.5097, ex I.M.I. Evaluation		45 21	1.5 37	2 37		12.5 46	7 37			Boost Sustain
4,016	Troy Motor Serial No.5103, ex Troop Trisls	15	10 25.5	7.5 81.5	3 59		7 70.5	3 70.5			Boost Sustain
4,022	Troy Motor Serial No.5033, ex I.M.I. Evaluation	24 55	9 24	16.5 37	6 52.5		7	2			Boost Sustain
4,017	Troy Motor, Serial No.5161, ex Bishopton + 4 SR.699 flares, 0.88" Lentex Liner Gas generator did not fire	18 53.5 83.5	6.5 23	4.5 16.5	3 55.5		3.5 55.5	0.5 28		30.5 40.5 83	Boost Sustain Flares
4,018	Troy Motors, Serial No.5158, ex Bishopton + 4 x SR.699 flares, 0.88" Lentex Liner, + Gas generator	23	5.5	4.5	3		11 55.5	3 41.5		25.5 39	Boost Sustain Flares + GG
4,020	Troy Motor, Serial No.5151, ex Bishopton + 4 x SR.699 flares, 0.88" Lentex Liner, + Gas generator	16 46 76 89					3 38.5	0.5 41.5		25.5 38.5 72.5 100	Boost Sustain Flares + GG
4,023	Troy Motor, Serial No.5160, ex Bishopton + 4 x SR.699 flares, 0.88" Lentex Liner, + Gas generator	23 53.5 76 92	6.5 20.5	4.5 10.5	2.5 49		9	0.5		30.5 48 83 100	Boost Sustain Flares + GG

* Inconsistent results

TABLE 5

AVERAGE SMOKE RESULTS FOR WARTON WIND TUNNEL/TUBE CONDITIONS

Details of devices fired	Firing phase	Average Transmission % over 7 metres	Number of results averaged	Spread of results	Attenuation per metre, dB (1) (Warton conditions)
4 flares 0.88" I.D. Lantex Liner SR.699		89	12	-7 + 7	0.07
4 flares 0.88" I.D. Kemetal Liner SR.699		86	11	-6 + 6	0.09
4 flares 0.75" I.D. Kemetal Liner SR.699		84	13	-14 + 11	0.10
4 flares 0.88" I.D. Lantex Liner SR.697		42	12	-8 + 10	0.53
Gas generator Mechanite 14		85	7	-10 + 5	0.10
Troy Motor	Boost	10	17	-9 + 15	1.43
	Sustain	55	12	-18 + 26	0.37
Troy Motor + 4 flares 0.88" I.D. Lantex Liner SR.699 + Gas generator	Boost	12	16	-11 + 19	1.34
	Sustain	45	11	-6 + 10	0.49
	Flares + GG	77	4	-4 + 6	0.16
	Flares	91	6	-8 + 9	0.06

(1) dB per metre = $\frac{1}{7} \times 10 \log (\text{Average transmission over 7 metres})^{-1}$

TABLE 6

AVERAGE SMOKE RESULTS CALCULATED TO MISSILE FLIGHT CONDITIONS

Details of devices fired	Firing phase	Transmission % through 34.2 metres smoke (1)	Attenuation/Metre (Flight conditions) DB x 10 ⁻² (1)
4 flares 0.88" I.D. Lantex Liner SR.699		86	1.9
4 flares 0.88" I.D. Kemetal Liner SR.699		82	2.5
4 flares 0.75" I.D. Kemetal Liner SR.699		80	2.7
4 flares 0.88" I.D. Lantex Liner SR.697		34	13.8
Gas Generator Mechancite 14		81	2.6
Troy Motor	Boost	5	37
	Sustain	47	9.6
Troy Motor + 4 flares 0.88" I.D. Lantex Liner SR.699 + Gas Generator	Boost	6	35
	Sustain	36	12.8
	Flares + GG	72	4.2
	Flares	89	1.5

(1) Angle between sight line and flight path is 1° according to B.A.C. flight model. Calculated as described in Appendix II, para.6.

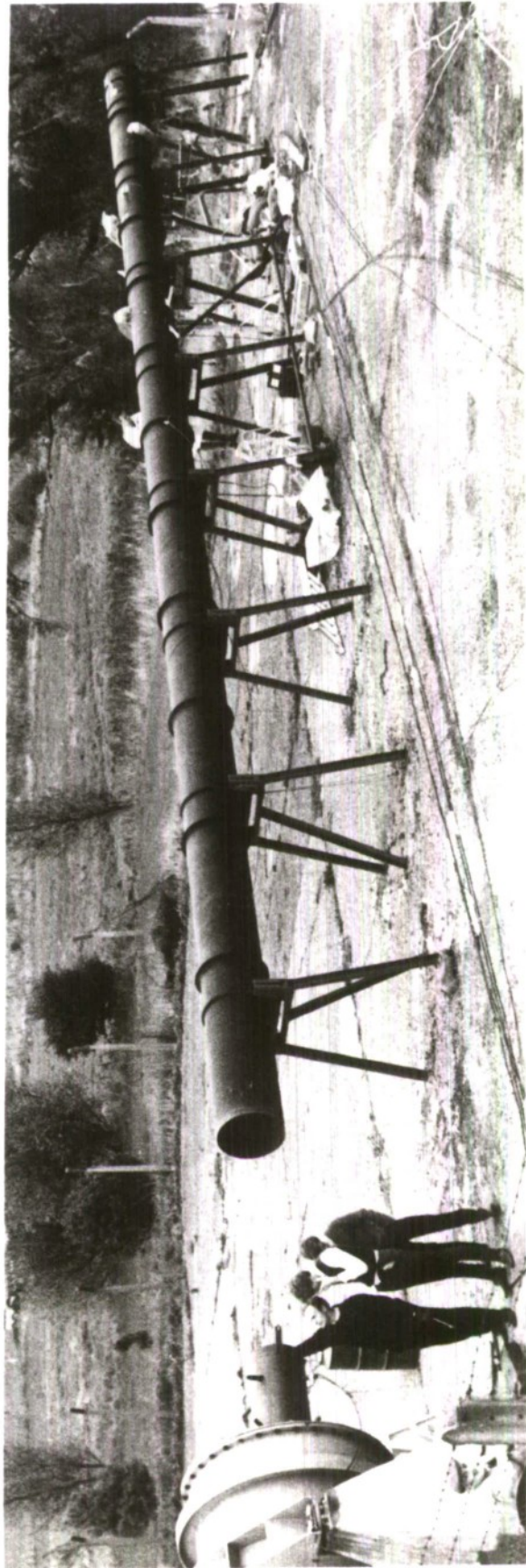
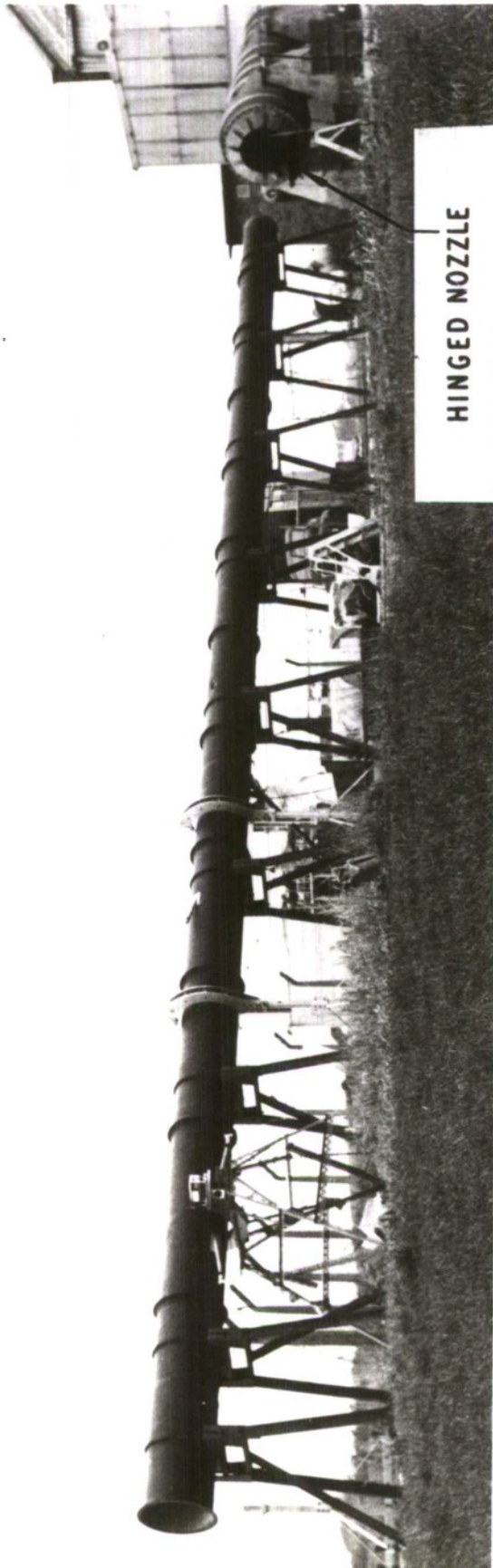

FIG. 1 GENERAL VIEWS OF THE TUBE AND WIND TUNNEL NOZZLE

CONFIDENTIAL

FIG. 2

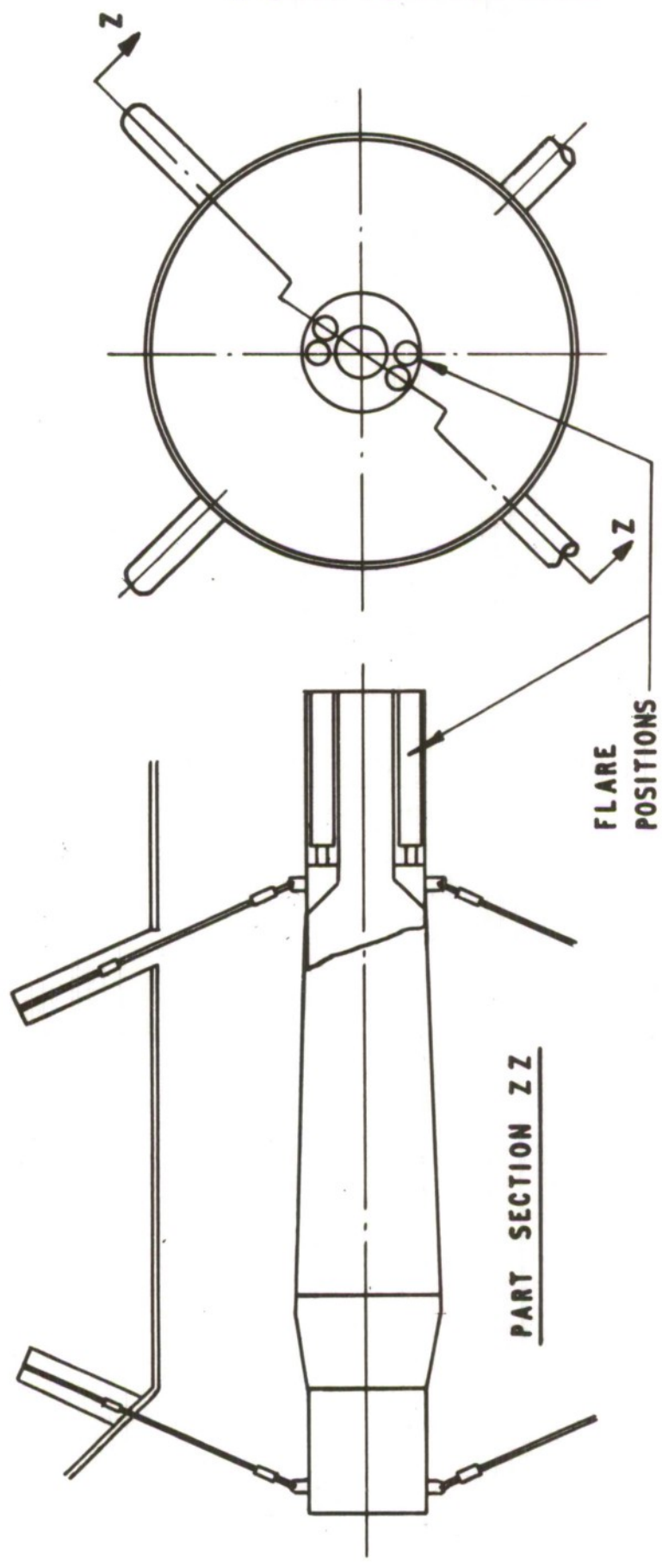

FIG. 2 FLARE MOUNTING IN WIND TUNNEL NOZZLE

CONFIDENTIAL

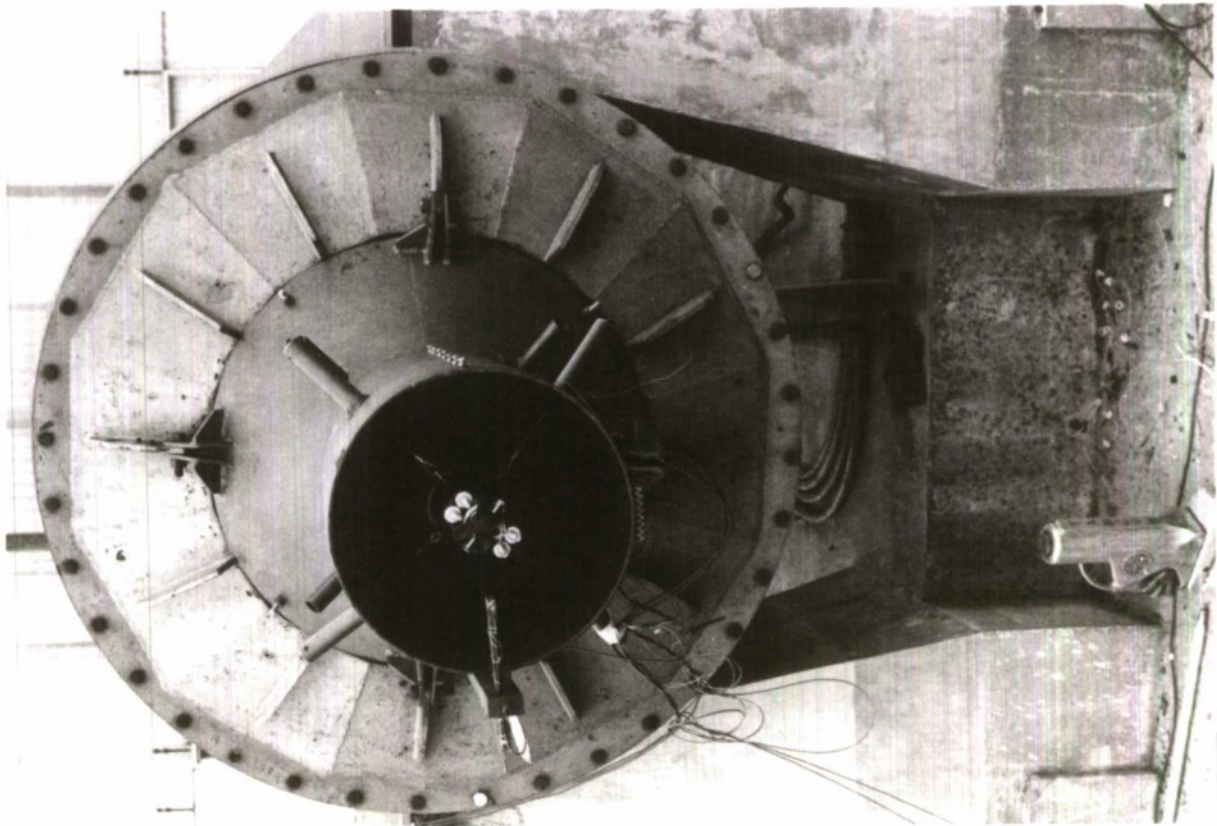
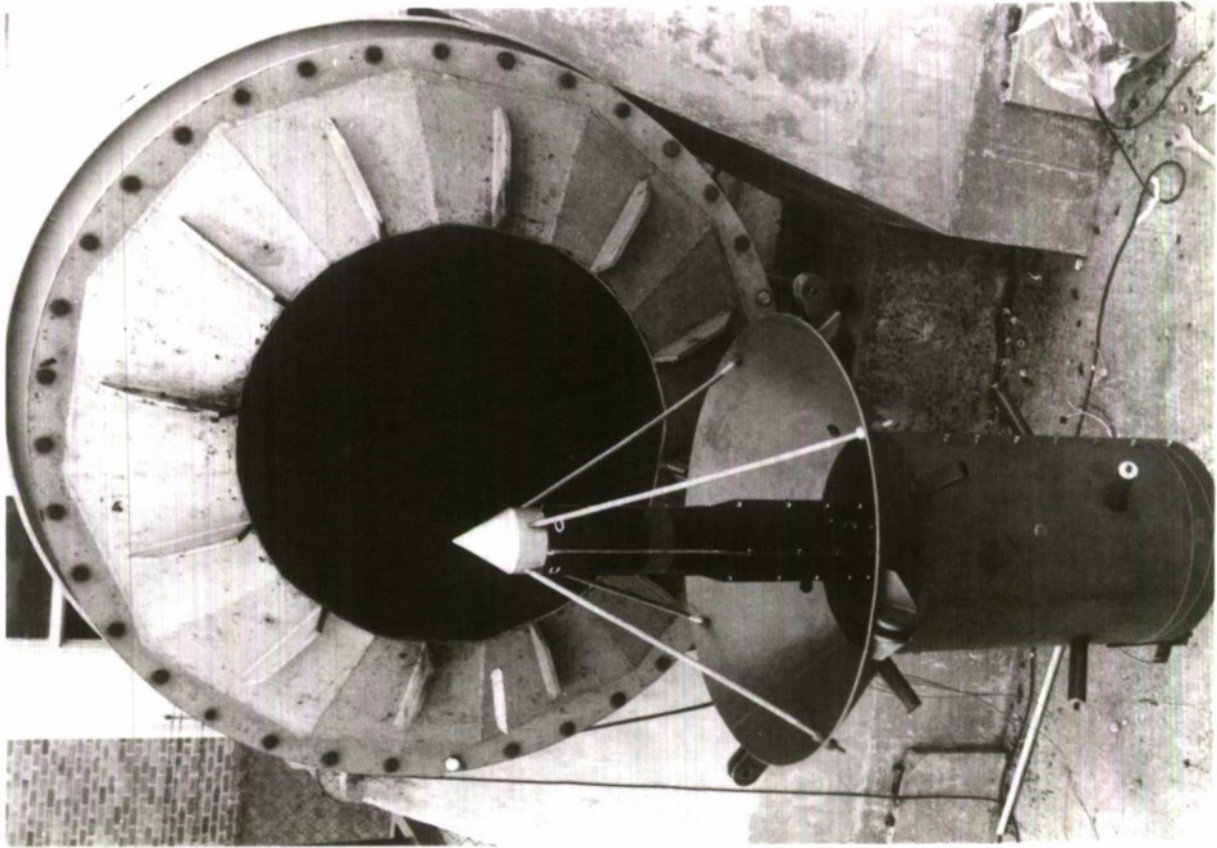
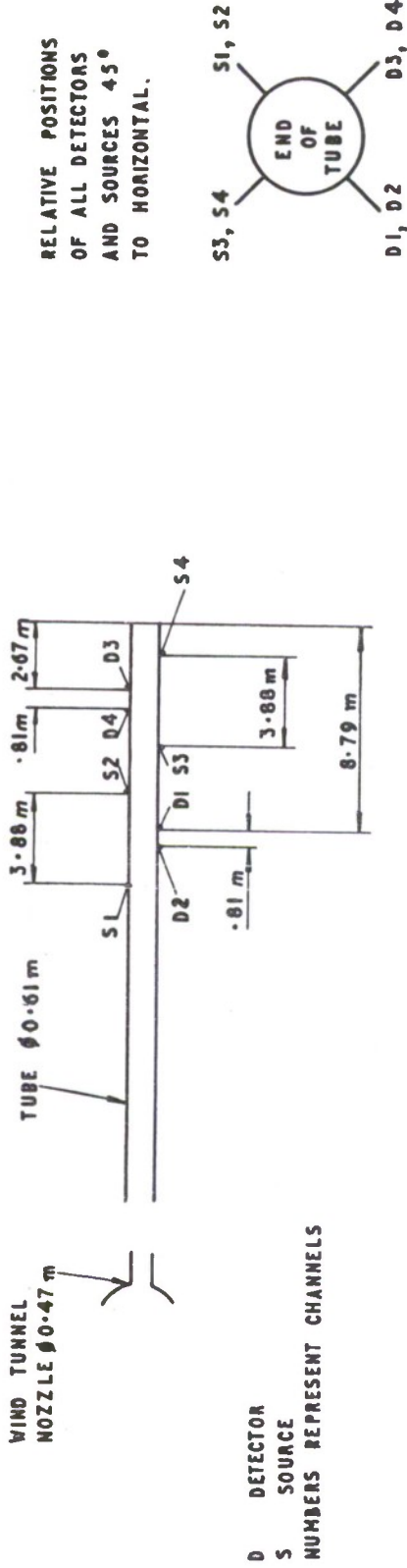

FIG. 3 (a) FLARES MOUNTED IN A TAIL CONE
(b) MOTOR MOUNTED READY FOR LIFTING
INTO A HORIZONTAL POSITION

CONFIDENTIAL

FIGS 4 (a)(b)



RELATIVE POSITIONS
OF ALL DETECTORS
AND SOURCES 45°
TO HORIZONTAL.

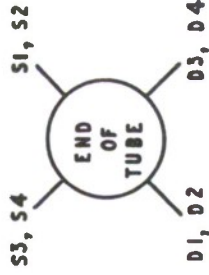

4 (a) LAYOUT OF DIAGONAL LIGHT PATH METHOD SYSTEMS

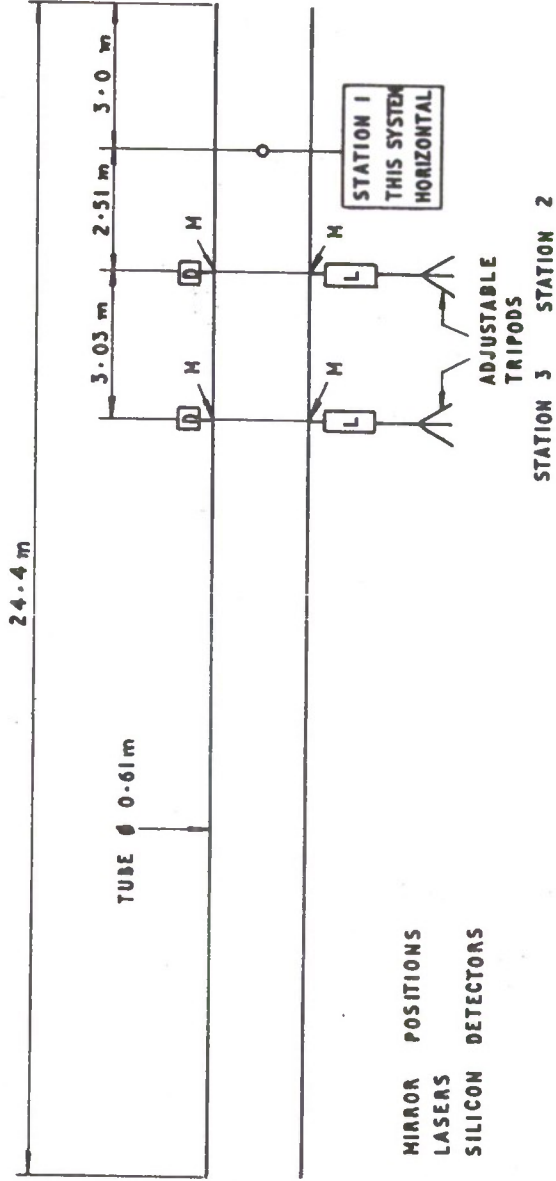

M MIRROR POSITIONS
L LASERS
D SILICON DETECTORS

ADJUSTABLE
TRIPODS

STATION 3 STATION 2
STATION 1
THIS SYSTEM
HORIZONTAL

4 (b) LAYOUT OF MIRROR METHOD SYSTEMS

CONFIDENTIAL

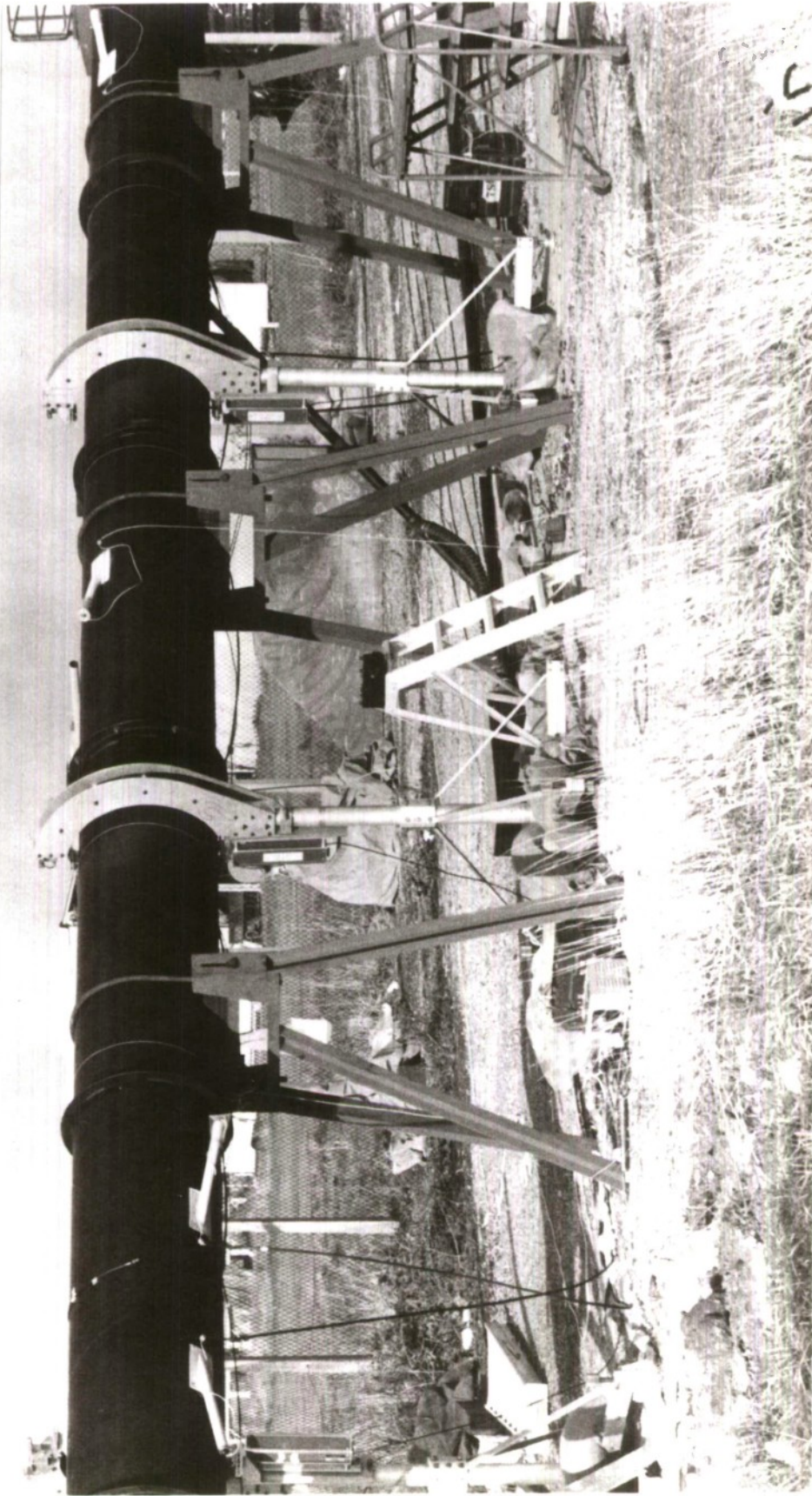

FIG. 5 VIEW SHOWING DIAGONAL LIGHT PATH METHOD
AND MIRROR METHOD SYSTEMS

FIG. 6

CONFIDENTIAL

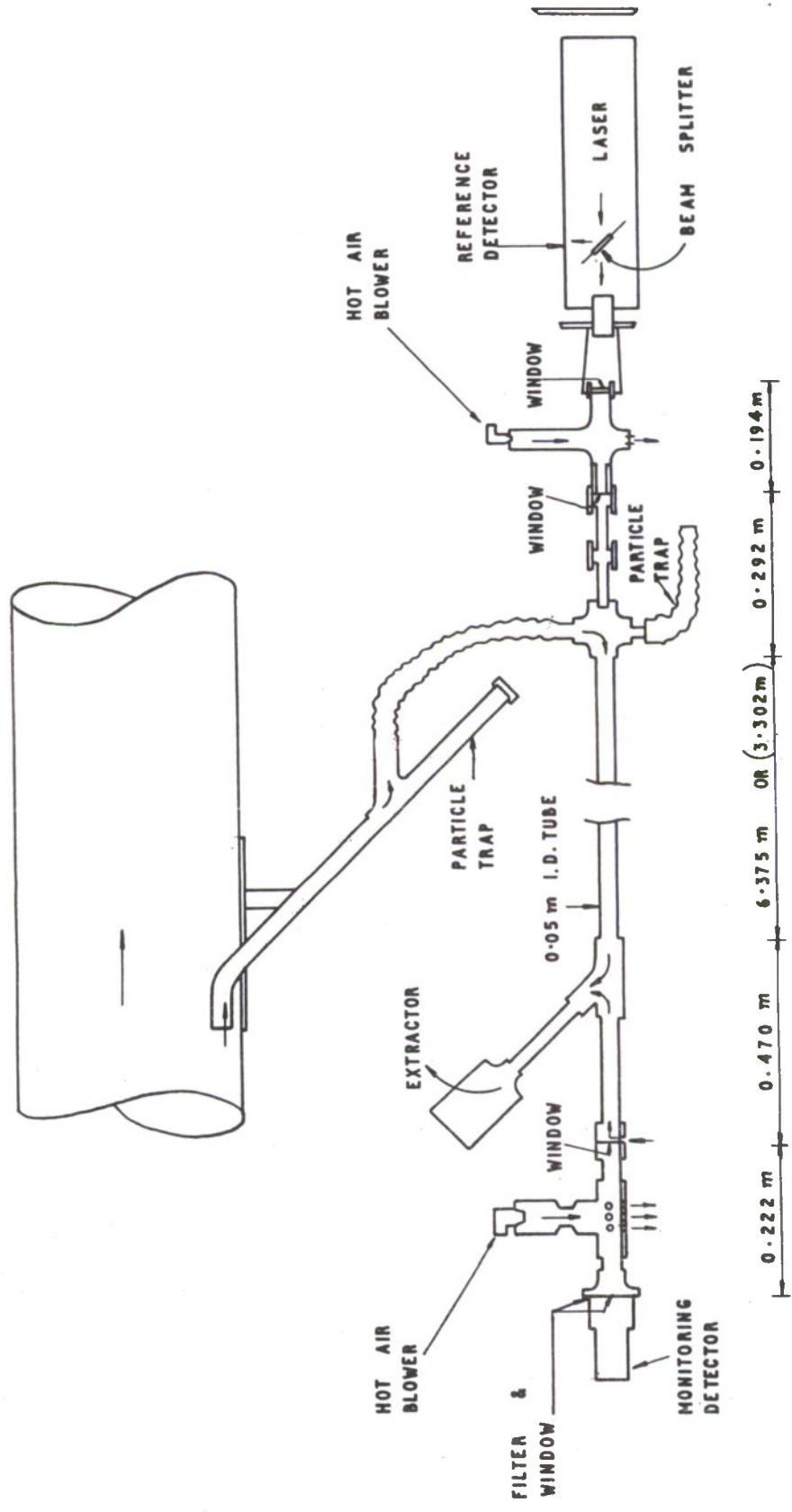

FIG. 6 LAYOUT OF SAMPLE TUBE

CONFIDENTIAL

CONFIDENTIAL

FI



FIG. 7 VIEW OF SAMPLE TUBE

CONFIDENTIAL



FIG. 8 VIEW SHOWING RADIOMETER POSITIONS

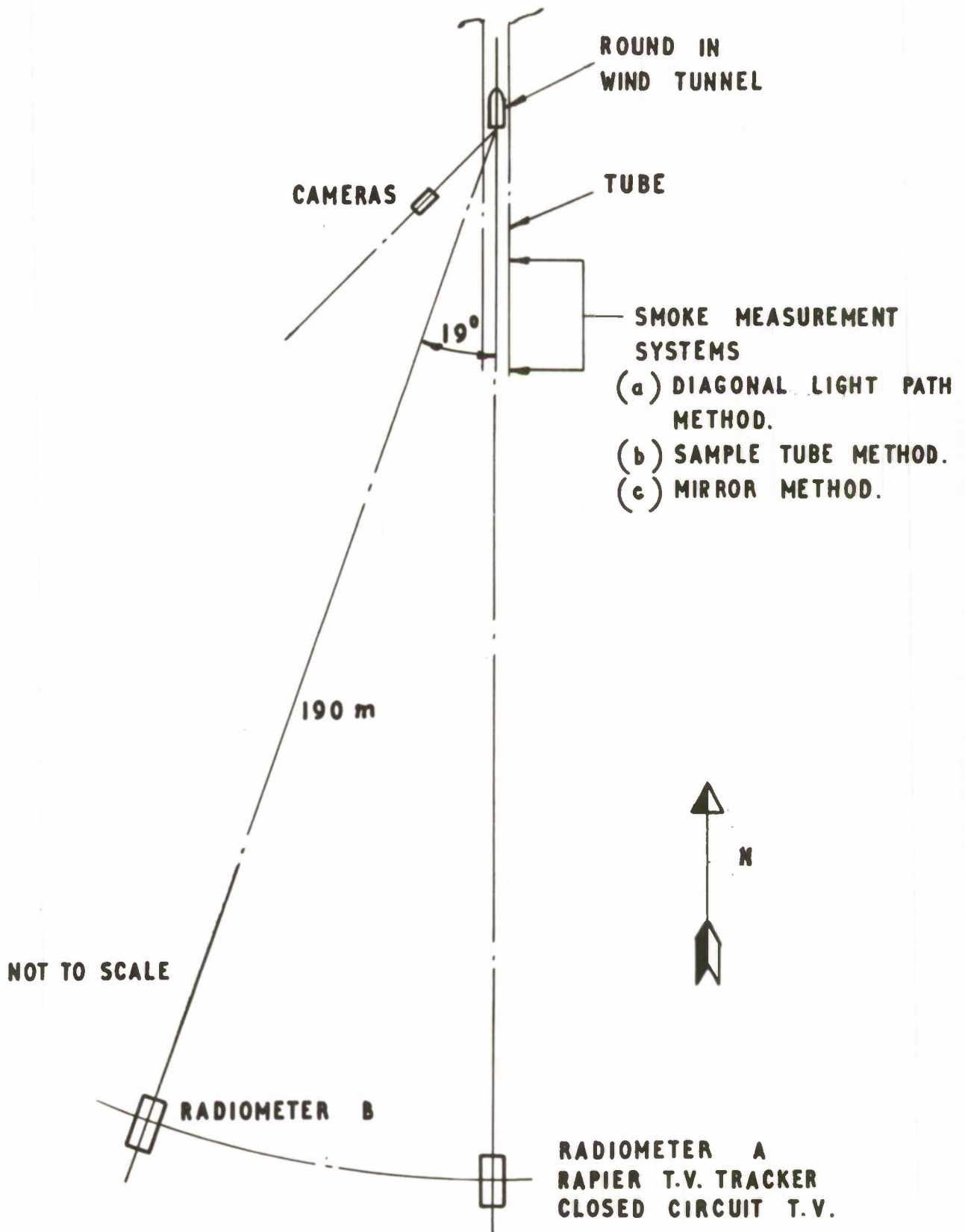

FIG. 9 DIAGRAM OF INSTRUMENTATION LAYOUT

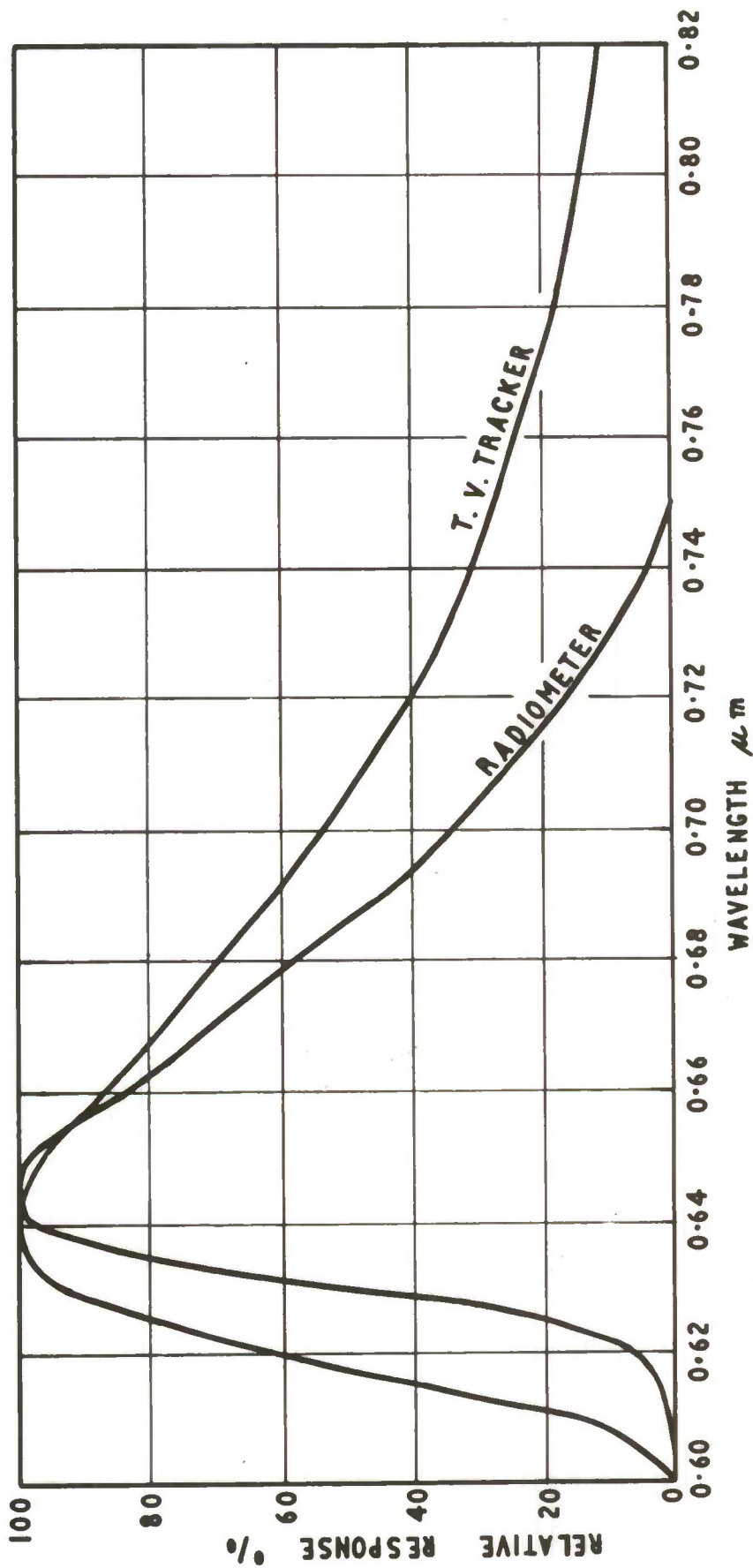
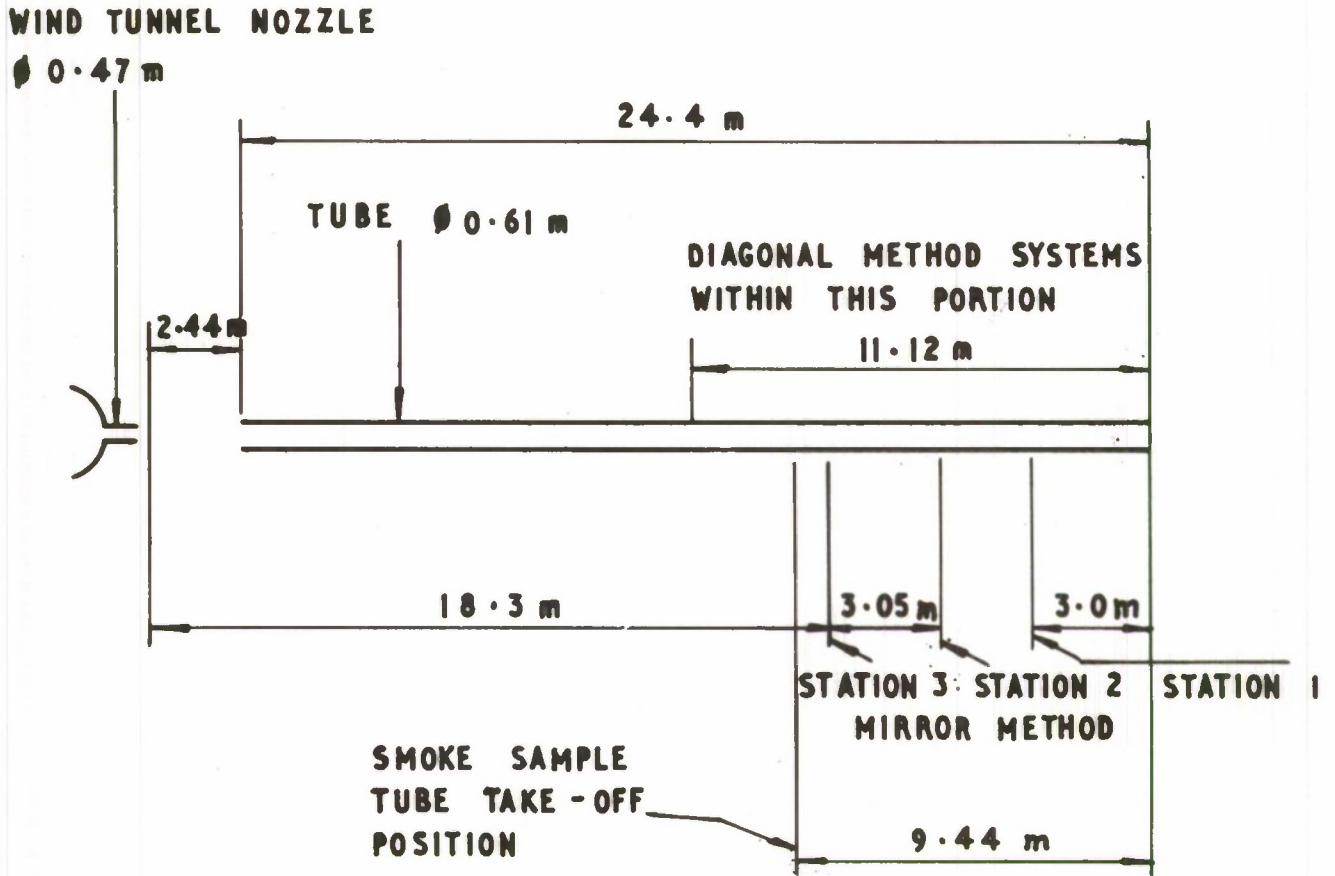
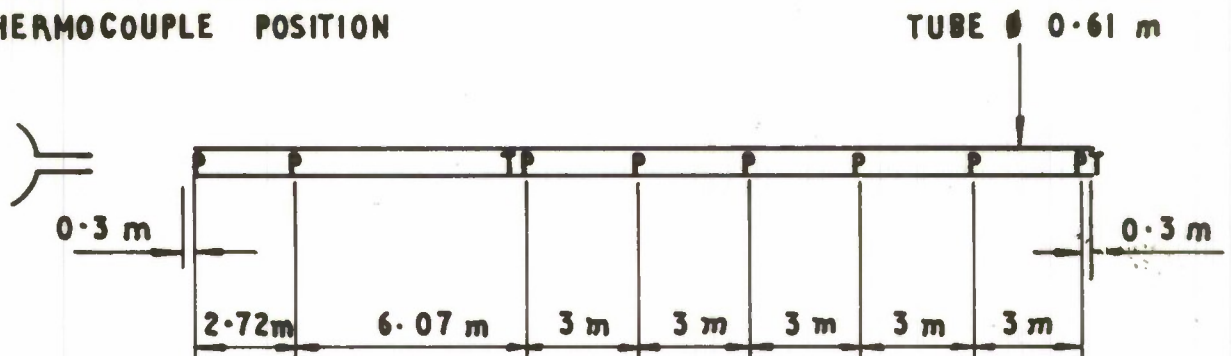

FIG. 10 RESPONSE CURVES FOR T.V. TRACKER AND RADIOMETERS



SMOKE ASSESSMENT SYSTEM POSITIONS

P-PITOT TUBE POSITION
T-THERMOCOUPLE POSITION



AIR VELOCITY MEASUREMENT SYSTEM POSITIONS

FIG. II DIAGRAM OF TUBE SHOWING SYSTEM POSITIONS

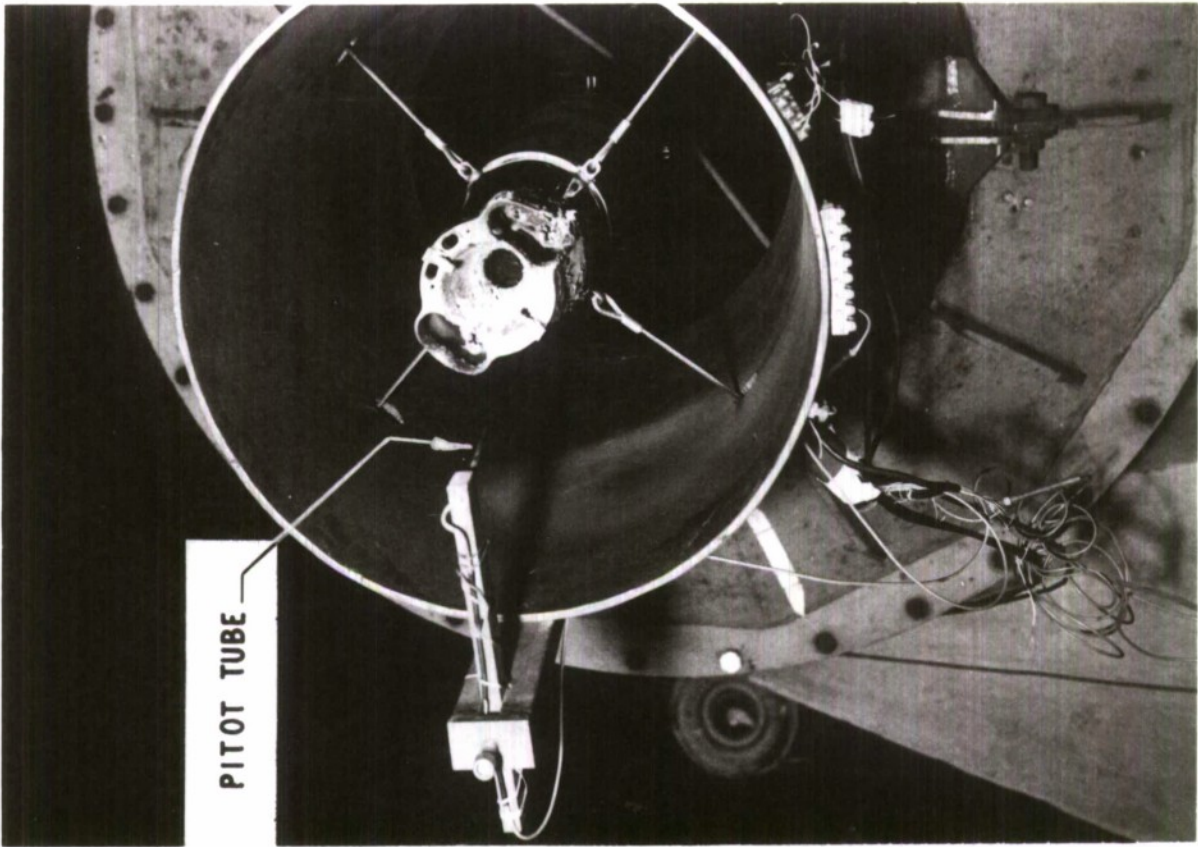

a

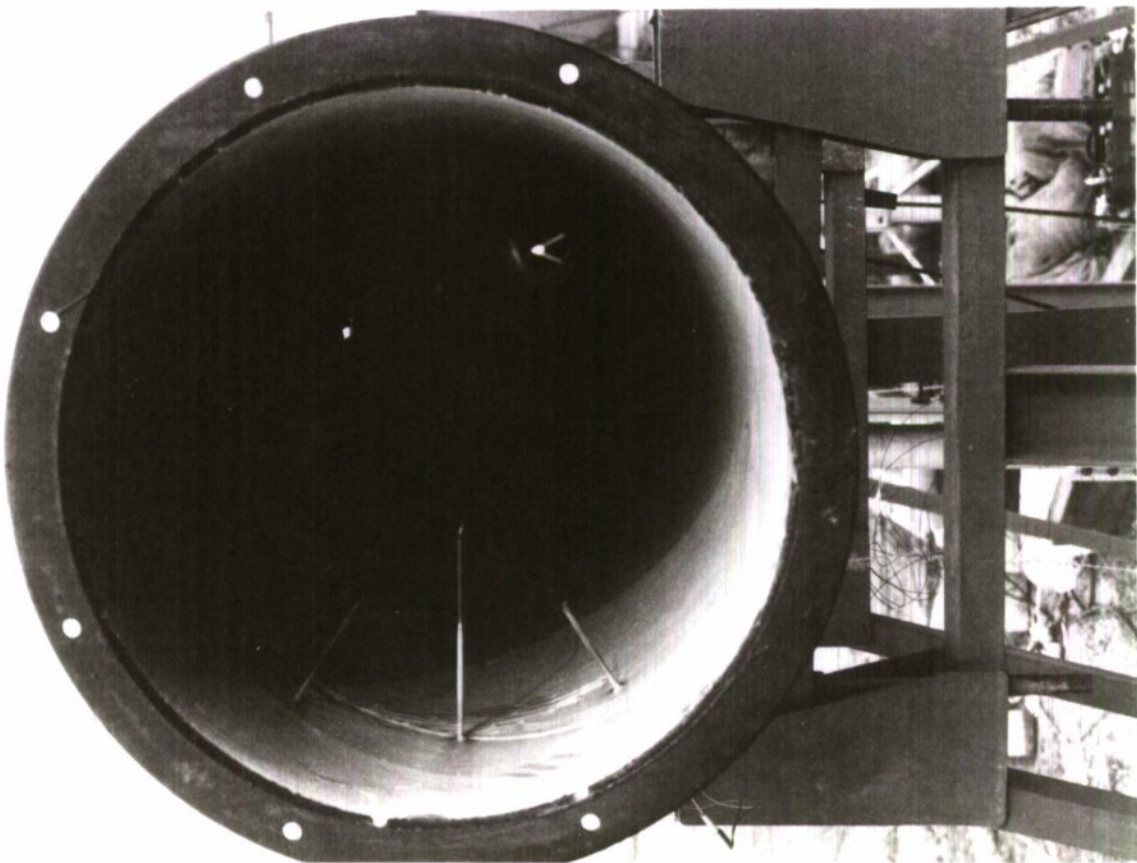

b

FIG. 12 (a) PITOT TUBES AT 0.3 METRES FROM TUBE EXIT.
(b) PITOT TUBE IN WIND TUNNEL.

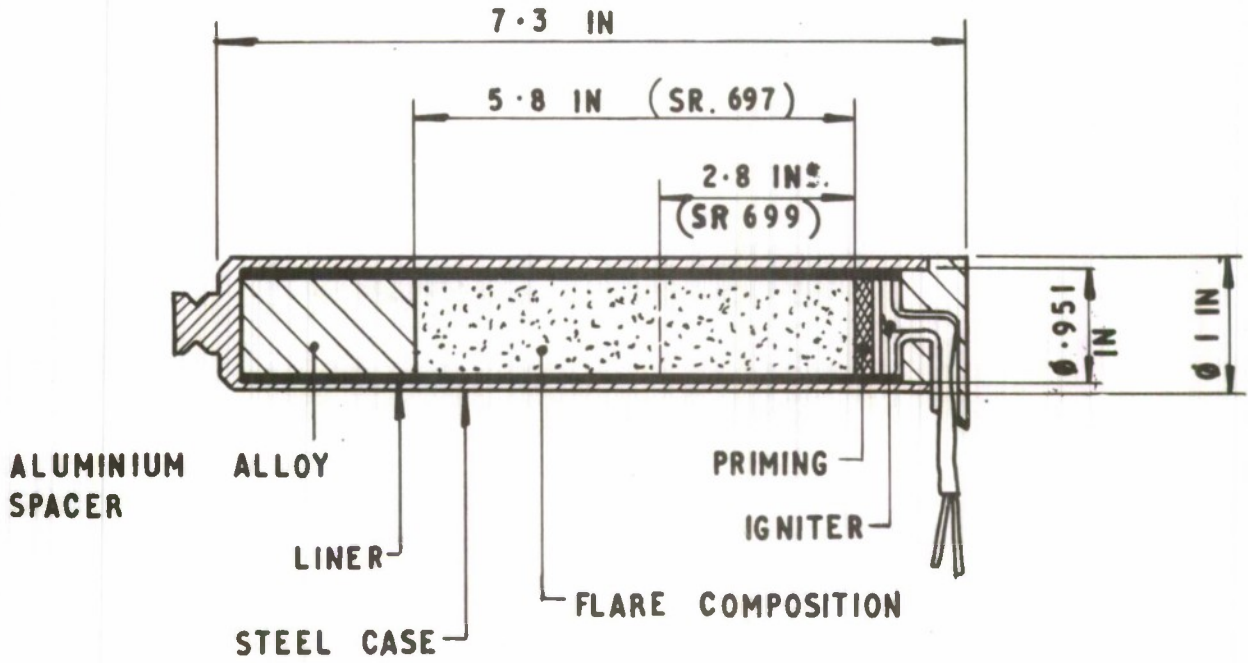

LINER DIMENSIONS (IN)

LINER MATERIAL	KEMETAL		LANTEX
INTERNAL DIAMETER	.88	.75	.88
EXTERNAL DIAMETER	.942	.942	.942

FLARE COMPOSITIONS

COMPOSITION	SR 699	SR 697
% TITANIUM	48	55
% STRONTIUM NITRATE	45	41
% ALLOPRENE	3	4
% BOILED LINSEED OIL	4	-
NUMBER OF INCREMENTS	7	14
WEIGHT OF COMPOSITION (gm)	71	144
LENGTH OF COMPOSITION (IN)	2.8	5.8

FIG. 13 RAPIER FLARE

CONFIDENTIAL

FIG. 14

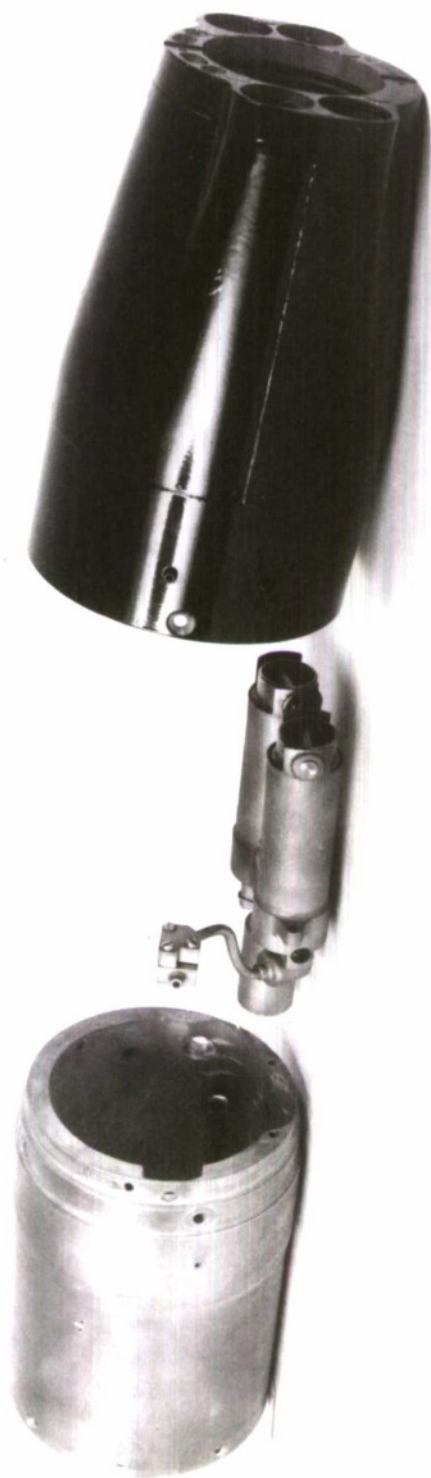

FIG. 14 GAS GENERATOR

CONFIDENTIAL



FIG. 15 GAS GENERATOR MOUNTING

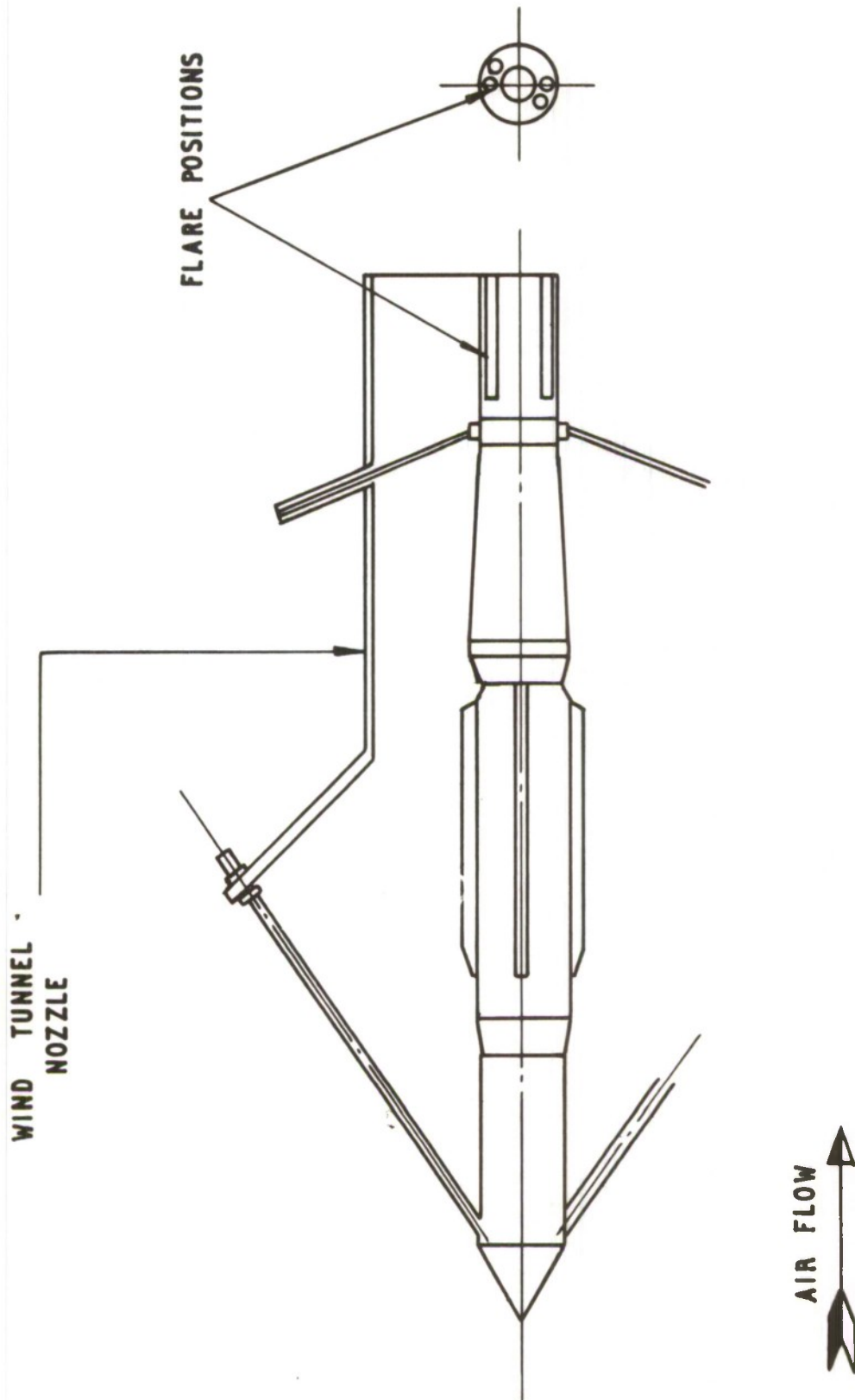
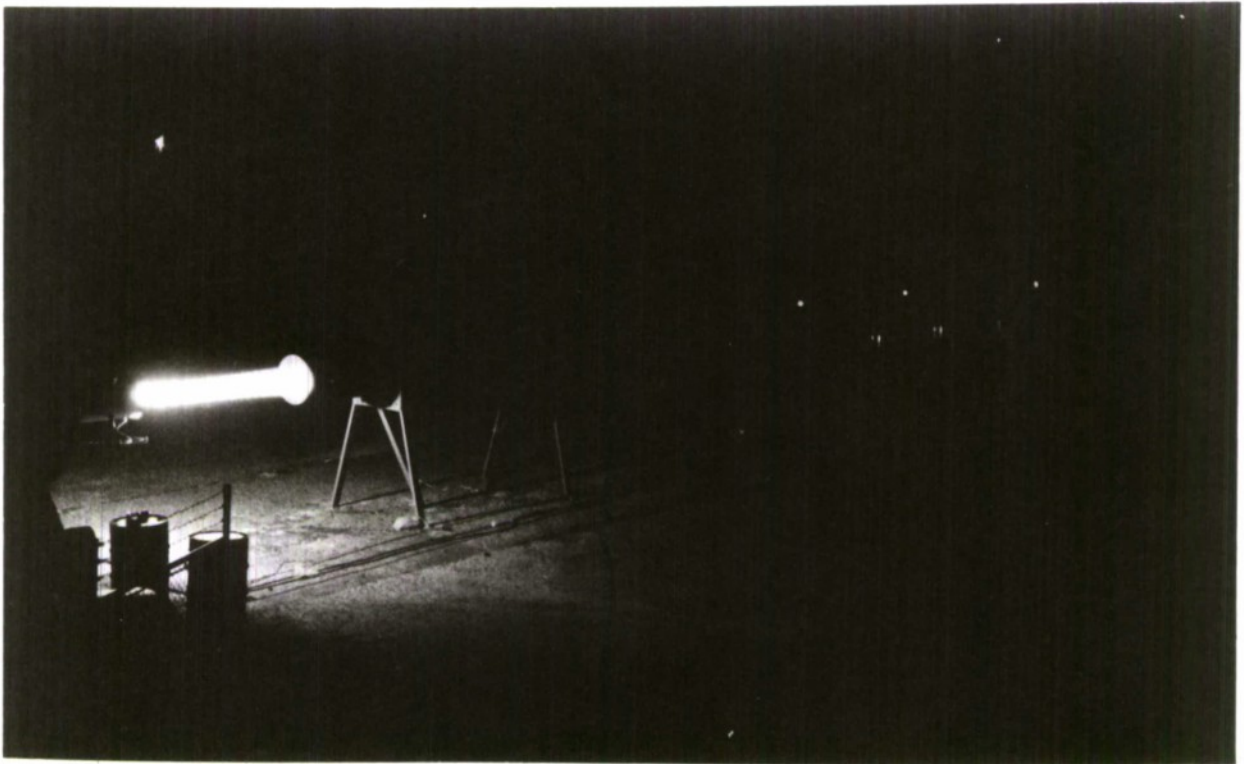
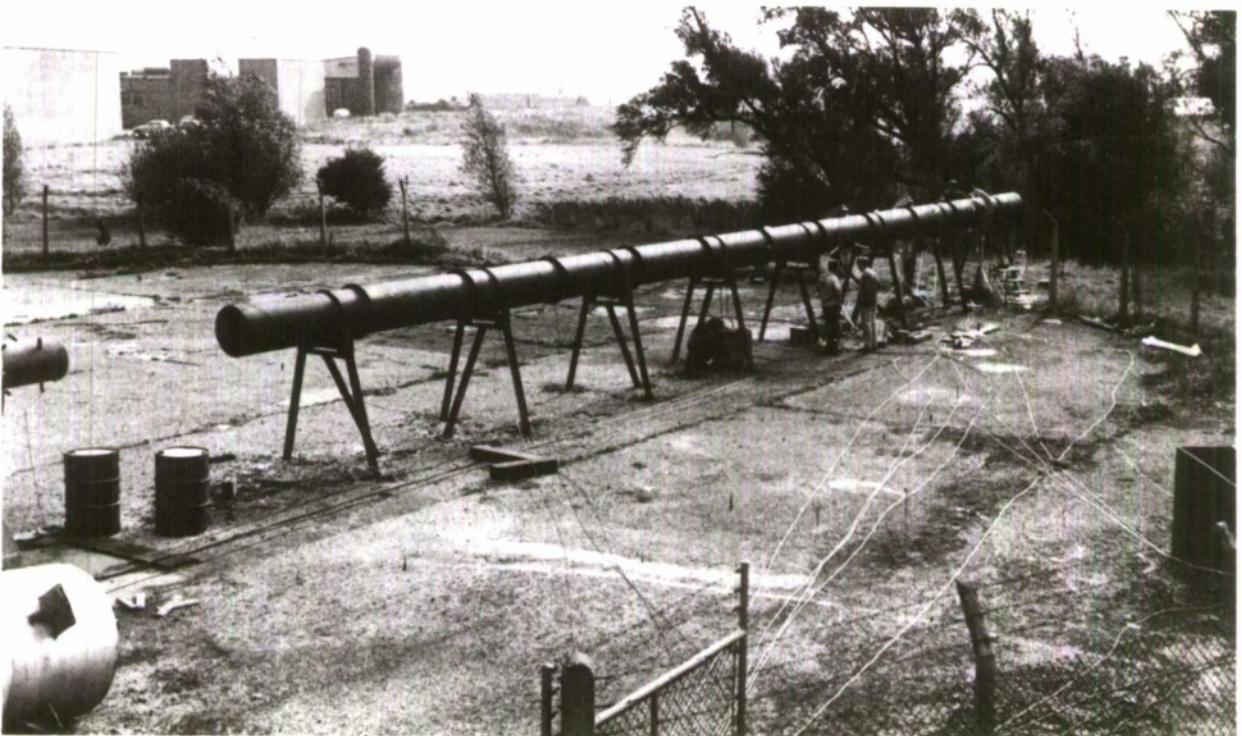

FIG. 16 MOTOR MOUNTING IN WIND TUNNEL NOZZLE



a



b

FIG. 17 (a) 4 FLARES BURNING IN 1.17 MACH WINDSTREAM
WITH EFFLUX ENTERING THE TUBE

(b) DAYLIGHT VIEW FROM SAME POSITION



a



b

FIG. 18 MOTOR BURNING IN (a) BOOST PHASE
(b) SUSTAINER PHASE

CONFIDENTIAL

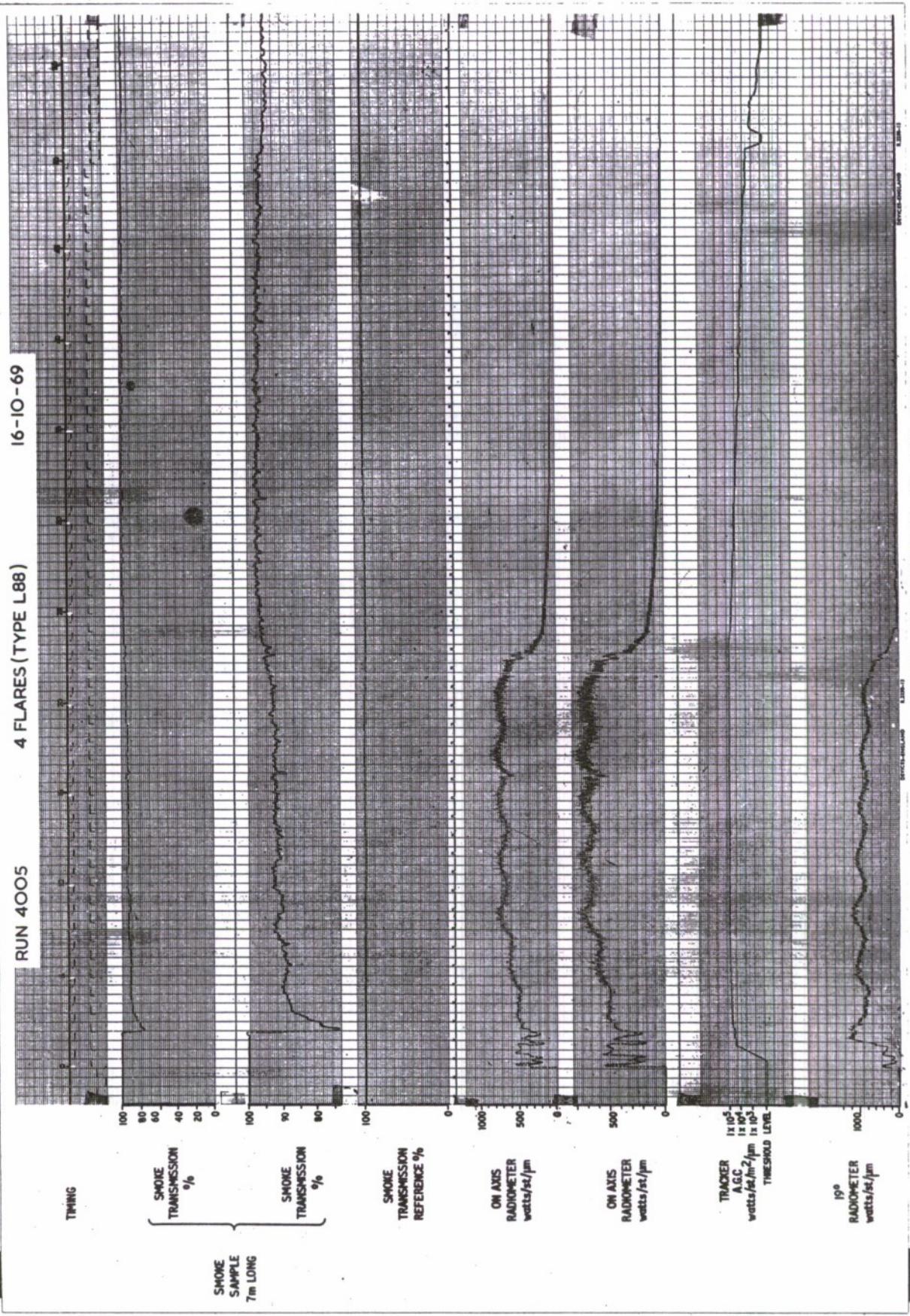

FIG. 19 RECORD OF SOME OF THE MEASUREMENTS OF RUN 4005

CONFIDENTIAL

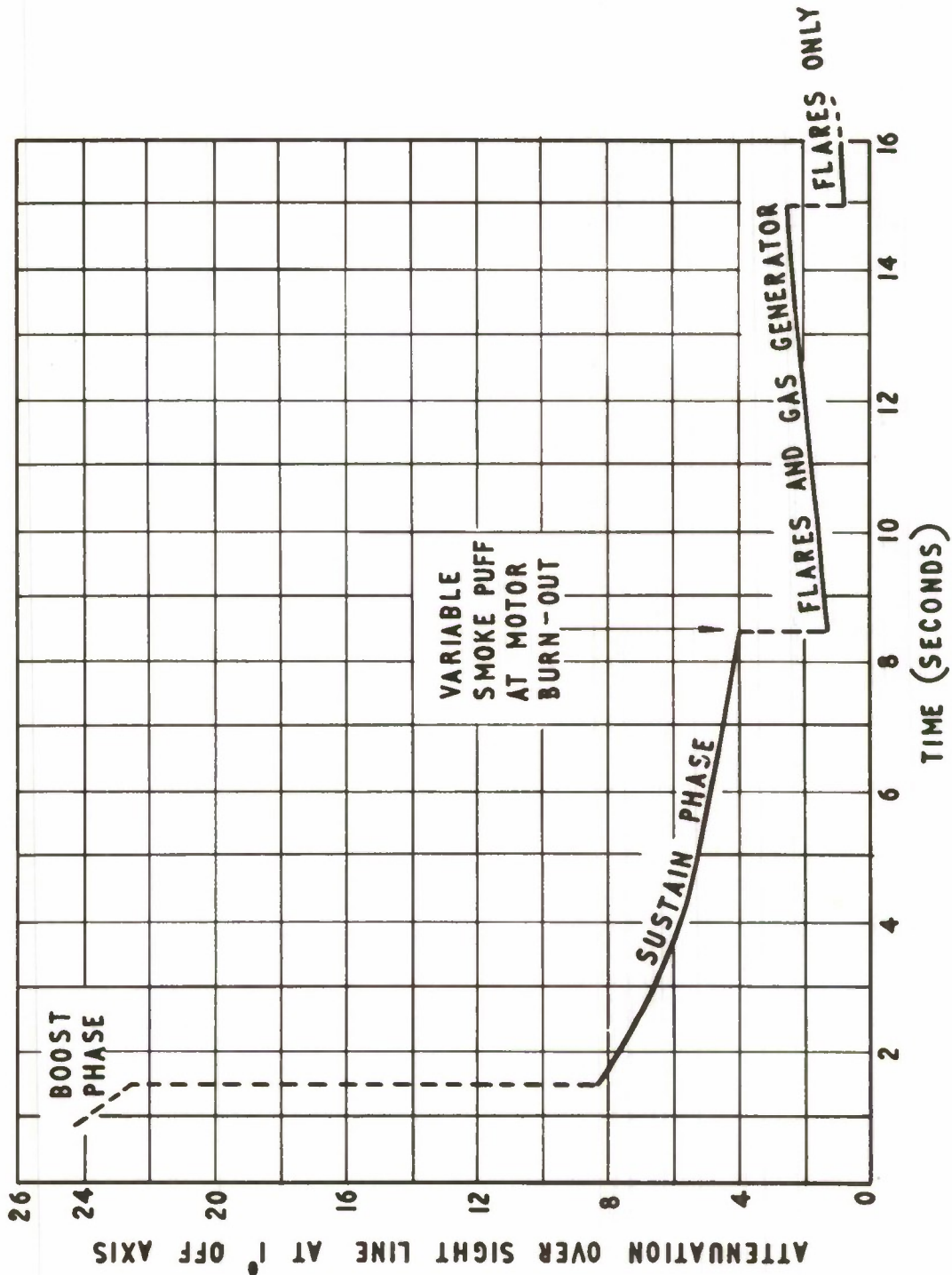

FIG. 20 PREDICTED ATTENUATION BY SMOKE THROUGHOUT FLIGHT

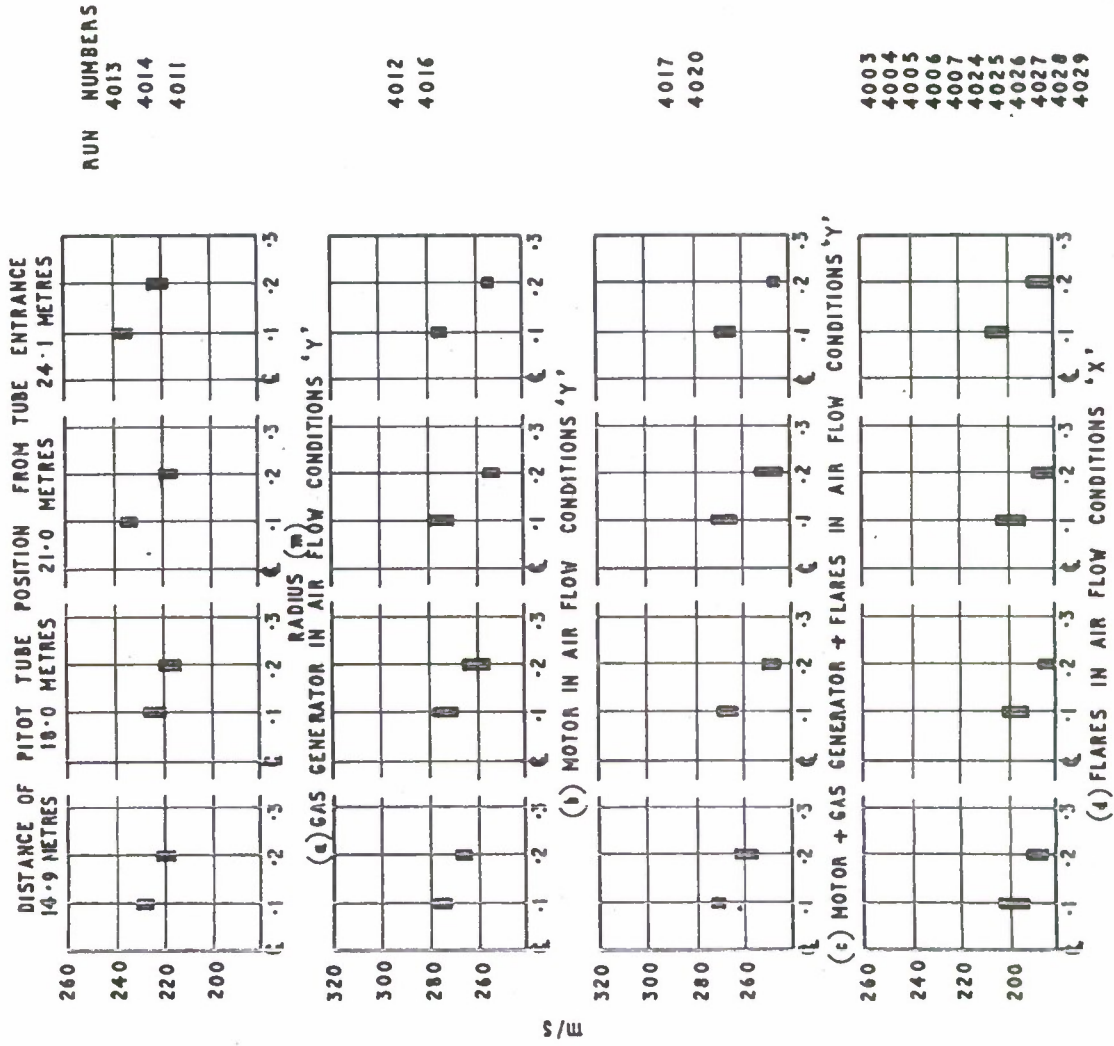

FIG. 21 VELOCITY DISTRIBUTIONS IN THE TUBE FOR THE VARIOUS STORES

FIG. 22

CONFIDENTIAL

1 GAS GENERATOR 4 FLARES (TYPE L88)
MOTOR No.5151

22 - 10 - 69

RUN 4020

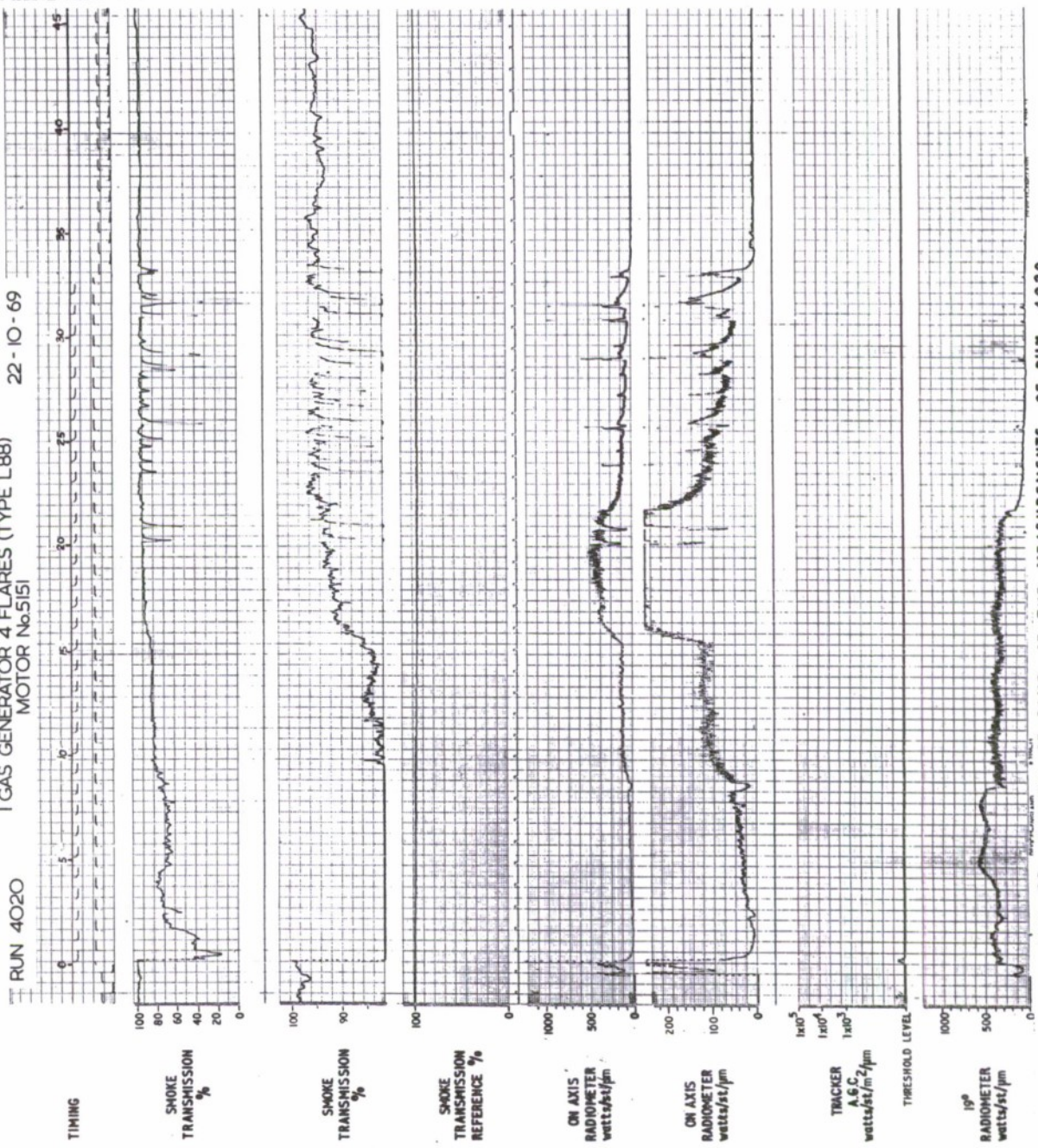

TIMING

SMOKE TRANSMISSION %

SMOKE TRANSMISSION %

SMOKE TRANSMISSION REFERENCE %

ON AXIS RADIO METER watts/ft²/μm

ON AXIS RADIO METER watts/ft²/μm

TRACKER A.G.C. watts/ft²/m²/μm

THRESHOLD LEVEL

19° RADIO METER watts/ft²/μm

SMOKE SAMPLE 4-1m LONG

FIG. 22 RECORD OF SOME OF THE MEASUREMENTS OF RUN 4020

CONFIDENTIAL

CONFIDENTIAL

Ministry of Defence

Royal Armament Research and Development Establishment

RARDE Memorandum 32/71

623.55.027:

623.451-519 Rapier:

621.455.019.9:

551.591

The assessment of smoke interference with the visibility of missile tracking beacons. Part I. General observations on the smoke problems and trials of Rapier missile components. (U)

Miriam Budgen, N.R. Williams

September 1971

A major problem with guided missiles which rely on visual or instrumental detection of light sources on the missile, in order to obtain information on the missile position relative to a target, is attenuation by missile smoke of the radiation emitted from such a source. Additionally smoke may obscure the target. A technique has been devised for measurement of the radiation attenuating properties of the smoke emitted by missile components, either separately or in combination, under simulated flight conditions. The values so obtained for a particular missile (Rapier) have been found comparable with the limited data available from free flight

CONFIDENTIAL

CONFIDENTIAL

Ministry of Defence

Royal Armament Research and Development Establishment

RARDE Memorandum 32/71

623.55.027:

623.451-519 Rapier:

621.455.019.9:

551.591

The assessment of smoke interference with the visibility of missile tracking beacons. Part I. General observations on the smoke problems and trials of Rapier missile components. (U)

Miriam Budgen, N.R. Williams

September 1971

A major problem with guided missiles which rely on visual or instrumental detection of light sources on the missile, in order to obtain information on the missile position relative to a target, is attenuation by missile smoke of the radiation emitted from such a source. Additionally smoke may obscure the target. A technique has been devised for measurement of the radiation attenuating properties of the smoke emitted by missile components, either separately or in combination, under simulated flight conditions. The values so obtained for a particular missile (Rapier) have been found comparable with the limited data available from free flight

CONFIDENTIAL

CONFIDENTIAL

Ministry of Defence

Royal Armament Research and Development Establishment

RARDE Memorandum 32/71

623.55.027:

623.451-519 Rapier:

621.455.019.9:

551.591

The assessment of smoke interference with the visibility of missile tracking beacons. Part I. General observations on the smoke problems and trials of Rapier missile components. (U)

Miriam Budgen, N.R. Williams

September 1971

A major problem with guided missiles which rely on visual or instrumental detection of light sources on the missile, in order to obtain information on the missile position relative to a target, is attenuation by missile smoke of the radiation emitted from such a source. Additionally smoke may obscure the target. A technique has been devised for measurement of the radiation attenuating properties of the smoke emitted by missile components, either separately or in combination, under simulated flight conditions. The values so obtained for a particular missile (Rapier) have been found comparable with the limited data available from free flight

CONFIDENTIAL

CONFIDENTIAL

Ministry of Defence

Royal Armament Research and Development Establishment

RARDE Memorandum 32/71

623.55.027:

623.451-519 Rapier:

621.455.019.9:

551.591

The assessment of smoke interference with the visibility of missile tracking beacons. Part I. General observations on the smoke problems and trials of Rapier missile components. (U)

Miriam Budgen, N.R. Williams

September 1971

A major problem with guided missiles which rely on visual or instrumental detection of light sources on the missile, in order to obtain information on the missile position relative to a target, is attenuation by missile smoke of the radiation emitted from such a source. Additionally smoke may obscure the target. A technique has been devised for measurement of the radiation attenuating properties of the smoke emitted by missile components, either separately or in combination, under simulated flight conditions. The values so obtained for a particular missile (Rapier) have been found comparable with the limited data available from free flight

CONFIDENTIAL

CONFIDENTIAL

firings, establishing reasonable confidence in the ability to use data obtained under these controlled conditions to predict effects in operational use. An important finding was that smoke measurements made under static conditions (no relative air flow) do not correlate with results obtained from dynamic firings (relative air flow - free flight or wind tunnel conditions).

50 pp 22 fig 9 tabs 8 refs

CONFIDENTIAL

CONFIDENTIAL

firings, establishing reasonable confidence in the ability to use data obtained under these controlled conditions to predict effects in operational use. An important finding was that smoke measurements made under static conditions (no relative air flow) do not correlate with results obtained from dynamic firings (relative air flow - free flight or wind tunnel conditions).

50 pp 22 fig 9 tabs 8 refs

CONFIDENTIAL

CONFIDENTIAL

firings, establishing reasonable confidence in the ability to use data obtained under these controlled conditions to predict effects in operational use. An important finding was that smoke measurements made under static conditions (no relative air flow) do not correlate with results obtained from dynamic firings (relative air flow - free flight or wind tunnel conditions).

50 pp 22 fig 9 tabs 8 refs

CONFIDENTIAL

CONFIDENTIAL

firings, establishing reasonable confidence in the ability to use data obtained under these controlled conditions to predict effects in operational use. An important finding was that smoke measurements made under static conditions (no relative air flow) do not correlate with results obtained from dynamic firings (relative air flow - free flight or wind tunnel conditions).

50 pp 22 fig 9 tabs 8 refs

CONFIDENTIAL

CONFIDENTIAL

THIS DOCUMENT IS THE PROPERTY OF HER BRITANNIC MAJESTY'S GOVERNMENT, and is issued for the information of such persons only as need to know its contents in the course of their official duties.

Any person finding this document will hand it in at a Military Unit or Police Station for its safe return to THE SECOND PERMANENT UNDER-SECRETARY OF STATE (ARMY), MINISTRY OF DEFENCE, LONDON, S.W.1, with particulars of how and where found. THE UNAUTHORISED RETENTION OR DESTRUCTION OF THE DOCUMENT IS AN OFFENCE UNDER THE OFFICIAL SECRETS ACTS OF 1911-1939.



CONFIDENTIAL



*Information Centre
Knowledge Services*
[dstl] *Defence Technical Information Centre*
11th Floor
11th Floor
22060-6218
Tel: +1 703 617 7233
Email: dstl@dstl.gov.uk

Defense Technical Information Center (DTIC)
8725 John J. Kingman Road, Suit 0944
Fort Belvoir, VA 22060-6218
U.S.A.

AD#: AD520062

Date of Search: 9 February 2009

Record Summary: DEFE 15/2105

Title: Assessment of smoke interference with visibility of missile tracking beacons: part 1
Former reference (Department): Memorandum 32/71
Held by The National Archives, Kew

This document is now available at the National Archives, Kew, Surrey, United Kingdom.

DTIC has checked the National Archives Catalogue website (<http://www.nationalarchives.gov.uk>) and found the document is available and releasable to the public.

Access to UK public records is governed by statute, namely the Public Records Act, 1958, and the Public Records Act, 1967.

The document has been released under the 30 year rule.

(The vast majority of records selected for permanent preservation are made available to the public when they are 30 years old. This is commonly referred to as the 30 year rule and was established by the Public Records Act of 1967).

This document may be treated as **UNLIMITED**.