

D-TDR-64-233

(FINAL REPORT)

A STUDY OF TACTICAL COMMUNICATIONS PROBLEMS

TECHNICAL DOCUMENTARY REPORT NO. ESD-TDR-64-233

MARCH 1964

Ralph C. Goodwin

482L/431L SYSTEMS PROGRAM OFFICE  
ELECTRONIC SYSTEMS DIVISION  
AIR FORCE SYSTEMS COMMAND  
UNITED STATES AIR FORCE  
L.G. Hanscom Field, Bedford, Massachusetts

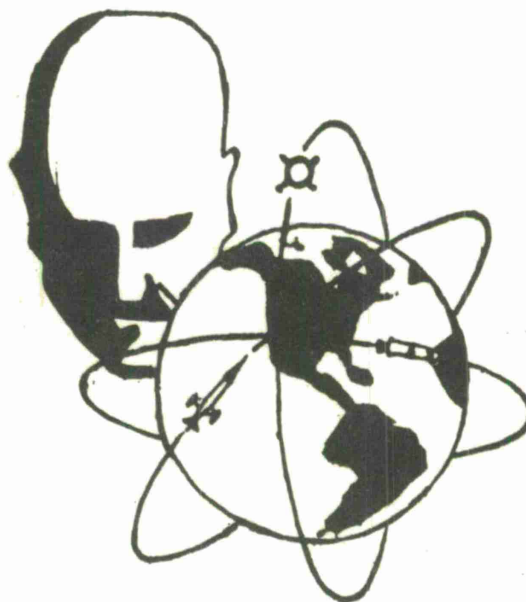

**ESTI PROCESSED**

DDC TAB  PROJ OFFICER

ACCESSION MASTER FILE

\_\_\_\_\_

DATE JUN 10 1964

ESTI CONTROL NR. AL 40662

CY NR 1 OF 1 CYS

System 482L

(Prepared under Contract No. AF 19 (628)-2915 by LFE Electronics, a division of Laboratory For Electronics, Inc., Boston 15, Massachusetts.)

**ESD RECORD COPY**

RETURN TO  
SCIENTIFIC & TECHNICAL INFORMATION DIVISION  
(ESTI), BUILDING 1211

AD601147

When US Government drawings, specifications or other data are used for any purpose other than a definitely related government procurement operation, the government thereby incurs no responsibility nor any obligation whatsoever; and the fact that the government may have formulated, furnished, or in any way supplied the said drawings, specifications, or other data is not to be regarded by implication or otherwise as in any manner licensing the holder or any other person or conveying any rights or permission to manufacture, use, or sell any patented invention that may in any way be related thereto.

Do not return this copy. Retain or destroy.

DDC AVAILABILITY NOTICES

Qualified requesters may obtain copies from Defense Documentation Center (DDC). Orders will be expedited if placed through the librarian or other person designated to request documents from DDC.

Copies available at Office of Technical Services, Department of Commerce.

## TABLE OF CONTENTS

	Page
FOREWORD	iii
ABSTRACT	iv
REVIEW AND APPROVAL STATEMENT	v
KEY WORD LIST	vi
LIST OF ILLUSTRATIONS	vii
LIST OF TABLES & CHARTS	viii
INTRODUCTION	1
I. AIR TRANSPORTABLE POINT-TO-POINT COMMUNICATIONS SUBSYSTEMS	3
A. BASIC CONCEPTS	3
B. COMMUNICATIONS REQUIREMENTS	8
C. ANALYSIS	10
D. SYSTEM DESIGN	20
E. CONCLUSIONS	25
F. RECOMMENDATIONS	25
II. TACTICAL HIGH FREQUENCY DIRECTIVE ANTENNA	27
A. STATEMENT OF WORK	27
B. MINIATURIZATION THROUGH RECONSTRUCTION OF PRESENT LOG PERIODIC	27
C. MINIATURIZATION THROUGH PURCHASE OF OFF-THE- SHELF HARDWARE	31
D. MINIATURIZATION THROUGH DEVELOPMENT OF STATE- OF-THE-ART TECHNIQUES	49
E. CONCLUSIONS	62
F. RECOMMENDATIONS	62

TABLE OF CONTENTS (Cont)

	Page
III. COMSEC PROBLEMS WITHIN THE EMS ENVIRONMENT	63
A. POINT-TO-POINT COMMUNICATIONS SYSTEMS	63
B. A/G/A COMMUNICATIONS	65
C. COMSEC HARDWARE INTEGRATION	65
D. CONCLUSIONS	65
E. RECOMMENDATIONS	66
IV. SUPPLEMENTARY MATTER	67
A. LIST OF REFERENCES	67
B. APPENDIX	73

## FOREWORD

The information contained herein is a result of technical study effort expended from March 3, 1963, to December 5, 1963. This study was sponsored by ESD under Contract AF19(628)-2915, LFE Project No. 971.

The authors of this report, R. C. Goodwin, A. L. Girard, and T. S. Narekian wish to acknowledge the assistance and aid received from:

- (1) Daniel F. DiFonzo of American Electronic Laboratories, Inc., for his suggestions on RF loading techniques of log-periodic antennas.
- (2) Professors Newell, Mayer, Howe, and Oyang of Worcester Polytechnic Institute for comments, suggestions, and references regarding the development of a theory of dielectric encased antennas.
- (3) Military and civilian personnel of the 482L Systems Program Office and in particular the Technical Support Division (ESSVM).

## TACTICAL COMMUNICATION STUDIES

### ABSTRACT

The study involved three technical problems.

1. Air transportable tactical communications subsystems that comply with pertinent security standards: A new set of security standards is in preparation and as yet is not available. Communications requirements were investigated and an overall communications plan presented which is compatible with existing and future tactical communications systems. This study shows that the alternate routed communications system plan (see Figure 2) is feasible and two communications vans at both the main field and the satellite field are desirable.

2. Short range communications for air traffic control: ATC voice coordinated circuits will be required between multiple base complexes and neither line of sight VHF nor HF/SSB is suitable. Communications requirements were established. Investigation of LF-MF and UHF/SHF troposcatter for short and intermediate ranges were accomplished. Results indicate that tropospheric scatter is most reliable for ranges of 15 to 200 miles and HF for ranges in excess of 200 miles.

3. Specifications of a tactical HF directional antenna: Current log monopole antennas are bulky and require too much set up time. Results indicate three approaches can alleviate the bulk, weight, erection problems.

Inductive loading techniques.

Purchase of off-the-shelf hardware.

Development of state-of-the-art designs.

REVIEW AND APPROVAL

Publication of this Technical Documentary Report ESD-TDR-64-233 does not constitute Air Force approval of the report's findings or conclusions. It is published only for the exchange and stimulation of ideas.

KEY WORD LIST

1. COMMAND & CONTROL SYSTEMS
2. COMMUNICATIONS SYSTEMS
3. AIR TRAFFIC CONTROL SYSTEMS
4. PORTABLE
5. AIR TRANSPORTABLE
6. MOBILE

## LIST OF ILLUSTRATIONS

Figure		Page
1	Third Degree Alternate Routed System	6
2	Recommended Alternate Routing System	7
3	Frequency Dependence of Troposcatter Paths Relative to Free Space	14
4	Troposcatter Path Response using 10 ft. Parabolic Antenna Over a 100 Mile Path	15
5	Diffraction Path Response Smooth Sphere 10 ft. Parabolic Antenna	16
6	Frequency Dependence of Gain and Beamwidth for 10 ft. Parabolic Antenna	17
7	Satellite Field Communications: Block Diagram	22
8	Main Airfield Communications: Block Diagram	23
9	Comcenter: Block Diagram	24
10	"Project Tobacco Can": Block Diagram	75
11	"Project Tabacco Can": Configuration	76

## LIST OF TABLES

Table		Page
1	Transportable Antenna Characteristics	33
2	Antenna Characteristics	34
3	Determining Range of Communications for Given Frequency of Transmission	52
4	Determining Range of Communications for Given Frequency of Transmission	53
5	Determining Range of Communications for Given Frequency of Transmission	55
6	Determining Range of Communications for Given Frequency of Transmission	57
7	Determining Range of Communications for Given Frequency of Transmission	58
8	Determining Range of Communications for Given Frequency of Transmission	60

## LIST OF CHARTS

Chart		Page
1	E and F Layers Electron Density	40
2	E and F Layers Virtual Height	41
3	MUF for Angle of Incidence	42
4	Frequency-Range for Log Periodic Ant.	43

## INTRODUCTION

Tactical Communications Problems involve a field of study that could be never ending. It encompasses such areas as who is to use the facilities, where it is to be used and how. What facilities it is to work with and what systems it is to be compatible with. What equipment should be supplied and how many channels of communication should be provided. What type of communications are available and the classification of traffic that may be handled. How the equipment is to be transported and set in operation after it is deployed. What will be the optimum frequencies to use for a certain range or what type of communication equipment should be used for the conditions. All these questions along with many more need answering for not only existing requirements but for future needs.

This study attempts to answer some of these questions with emphasis on particular areas specified by the work statement.

The specific areas are:

1. Design of an Air-Transportable Point-To-Point Tactical Communications Subsystem.
2. Design of a Tactical High Frequency Directional Antenna.
3. Investigate Short Range Point-To-Point Communications.
4. Investigate Security Requirements for EMS Point-To-Point Communications Equipment to meet current DOD COMSEC standards.

The contract started in March of 1963 and was supplemented in December of 1963. Termination was made in February of 1964, and it was requested at that time to complete a Final Report.

Because of the broad field to be covered and the many variables involved, it was expedient to set certain limitations of areas of investigation. It was also to our advantage to utilize the AN/TSQ-47 Air Traffic Control/Communication System as the basis for discussion and recommendations. Our past studies on

the AN/TSQ-47 System along with our present close working association with the Engineering Directorate of this system permitted us to evaluate and recommend changes on an existing system. It also permitted us to observe the results of our previous studies and determine the accuracies of our statements. To date we feel our past performance has been sufficiently accurate to give us confidence in the contents of this report.

The report is directed toward providing a suitable point-to-point communications capability working in an EMS environment. It includes tactical concepts for limited warfare, natural disasters or a show of force. It also includes discussions of communication requirements with regard to range, frequencies, type and number of channels and modulation systems. An analysis of LF-MF and troposcatter communications is provided. A thorough investigation of high frequency directional antennas has been conducted along with a complete analysis of a new concept such as a dielectric antenna. A study of propagation conditions for high frequency communications is also provided with charts and tables to permit evaluation of the best frequencies to be used for any time during a year. The sun spot cycle variation facts are not included but could be easily applied to these tables.

Short range point-to-point communication means one thing to one group and something else to another group. It was difficult to have any one say what "short range" was in terms of distance. We arbitrarily settled on 40 miles since it was stated in the work statement, yet we investigated from 15 to 200 or more miles. This area alone could cover a complete report, but again time and manpower do not permit.

The fourth item specifically outlined to study was added to the original contract in the last month. This gave us no opportunity to set up a preliminary evaluation of the situation even though we had been collecting bits of data regarding the security problem throughout the previous study. It is an area where a great deal of work is required and the ground rules have not even been set.

One example is the standards for secure communications. There are no standards that take into account the requirement for air-transportable equipment. The physical layout is restricted to the confines of vans that may be air lifted and this in turn is limited to the capabilities of available aircraft. Current standards and directives do not allow for restricted space, and whenever this condition arises, there is a waiver issued. This is not a suitable arrangement since the need for systems that are secure and air-transportable must be met. Ways and means for providing this type of system are needed now, and it is envisioned the need will become increasingly urgent as time goes by.

## I. AIR TRANSPORTABLE POINT-TO-POINT COMMUNICATIONS SUBSYSTEMS

### A. BASIC CONCEPTS

#### 1. The EMS Environment

In the study of tactical communications systems, the tactical environment must play a major role in the selection of design criteria. For this reason, before any analysis of actual systems can take place, an analysis of the EMS environment as it affects equipment needs and operation must be undergone.

The environment itself is highly variable. It ranges from limited warfare, where the probability of enemy action is high, to the natural disaster, where there is an almost complete lack of facilities for power or transportation.

Under tactical deployment conditions in limited warfare, several needs become apparent. The equipment must be highly mobile to meet the fluidity of modern tactics. It must be capable of being located in remote areas for periods of time up to 90 days with limited resupply, and it must be sufficiently easy to operate so that training of casualty replacements is minimized. Such equipment must perform in climatic conditions ranging from the dry heat of the desert to the moist, fungus nourishing heat of the tropics; from the dry cold of the Arctic to the wet cold of the temperate zones.

These requirements are still necessary to operations in a show of force situation. Here nothing has been changed except that there is no actual contact with the enemy. The mobility is still necessary, since situations of this type require extremely fast reaction in order to be effective.

The emergency requirements of natural disasters closely approximate the requirements of a remote combat zone. Here, self-sufficiency of the combat system is essential. Equipment usually must be airlifted into the area and must operate reliably under its own power for extended periods, often under severe climatic conditions.

Therefore, based on this operational environment, the following requirements must be met by every subsystem of an emergency mission system:

- Mobility
- Air Transportability
- Simplicity of Operation
- Self-Sufficiency
- Climatic Adaptability
- Reliability

## 2. Tactical Concepts

In an Emergency Mission System, a major criterion for point-to-point communications is the elimination of susceptibility to communications breakdown due to enemy action or equipment failure.

This susceptibility is reduced by careful design of a basic communication plan embodying varying degrees of alternate routing.

A first degree alternate routed system is defined for purposes of this report as a system in which lateral links are made at the lowest command level (satellite field to satellite field) and vertical links (following the chain of command) are made at all levels.

A second degree alternate routed system is defined for purposes of this report as a system in which lateral links are made at the two lowest command levels (satellite field to satellite field and main field to main field) vertical links being made to all higher levels.

A third degree alternate routed system is defined for purposes of this report as a system in which the lowest command levels in a second degree system are linked in an emergency network to headquarters thereby bypassing the next higher command level.

The most susceptible of these systems is the first degree system, for, using the EMS example, if communications to the main field are lost for any reason, the satellites are isolated and can only communicate with each other. The chain of command has been broken.

The second degree system does not totally solve this problem, since it merely allows lateral communications between main fields, giving alternate routing along other vertical communications axes. It is then, the third degree system which eliminates these difficulties, leaving an unbroken chain of command under all conditions. It is, however, costly in money, men, and equipment to implement a third degree system at this time. A diagram of a sample third degree system is shown in Figure 1.

A compromise solution to this problem involves elimination of direct lateral communication at the second command level, and the remaining links are unchanged. This compromise solution breaks down into three major areas, each defining a basic communication system. Refer to Figure 2.

- (1) Satellite fields communicate with each other and with main fields by tropospheric scatter.
- (2) Emergency communications, bypassing main air fields to higher headquarters or to Aircom gateway stations is by HF single sideband multiplex teletype and voice. This is a half-duplexed directed net which is to be used for back-up purposes only.

- Aircom Gateway or Headquarters
- △ Main Air Fields
- Satellite Fields
- - - HF SSB Emergency Net
- - - UHF Relay
- - - Tropo
- HF ISB

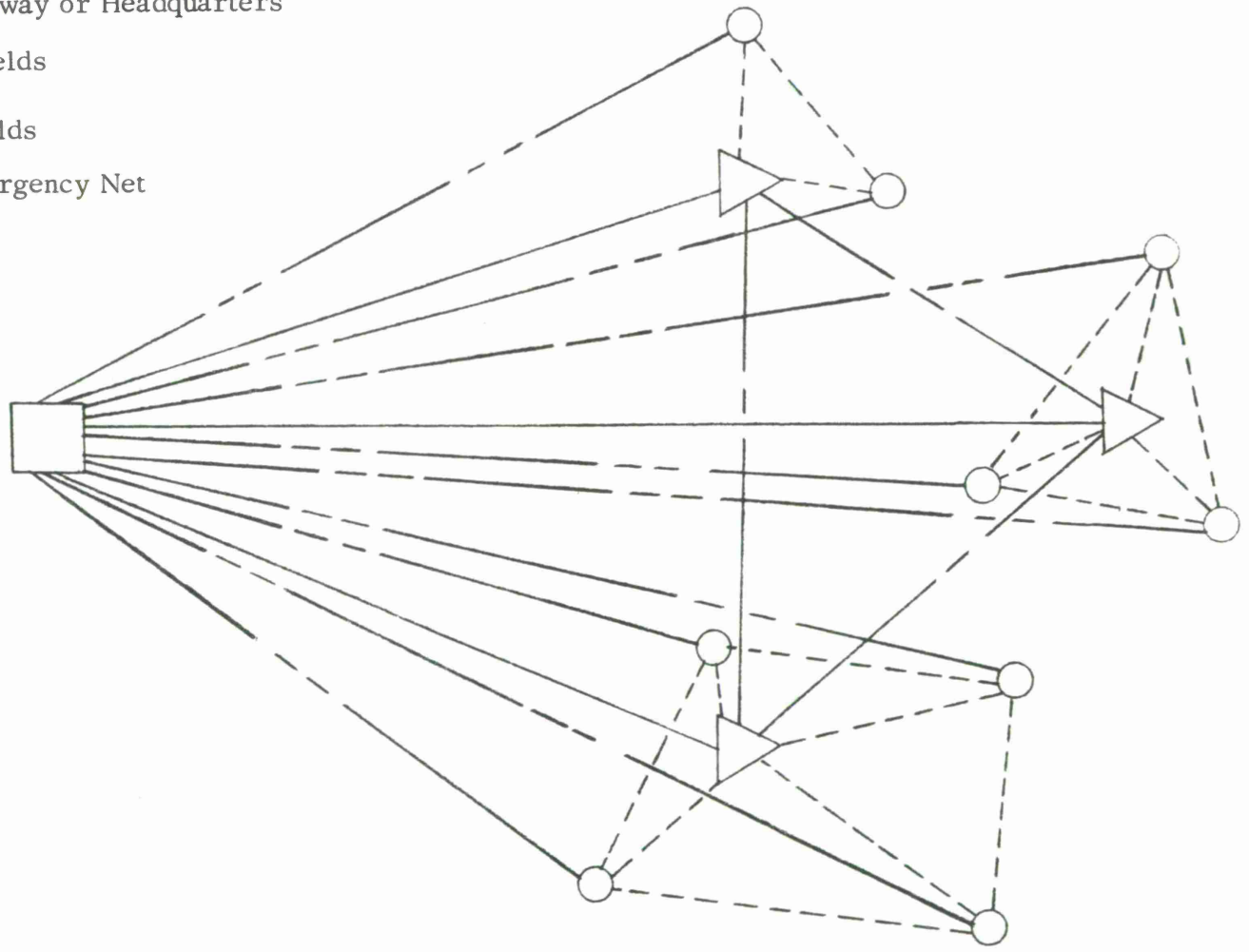
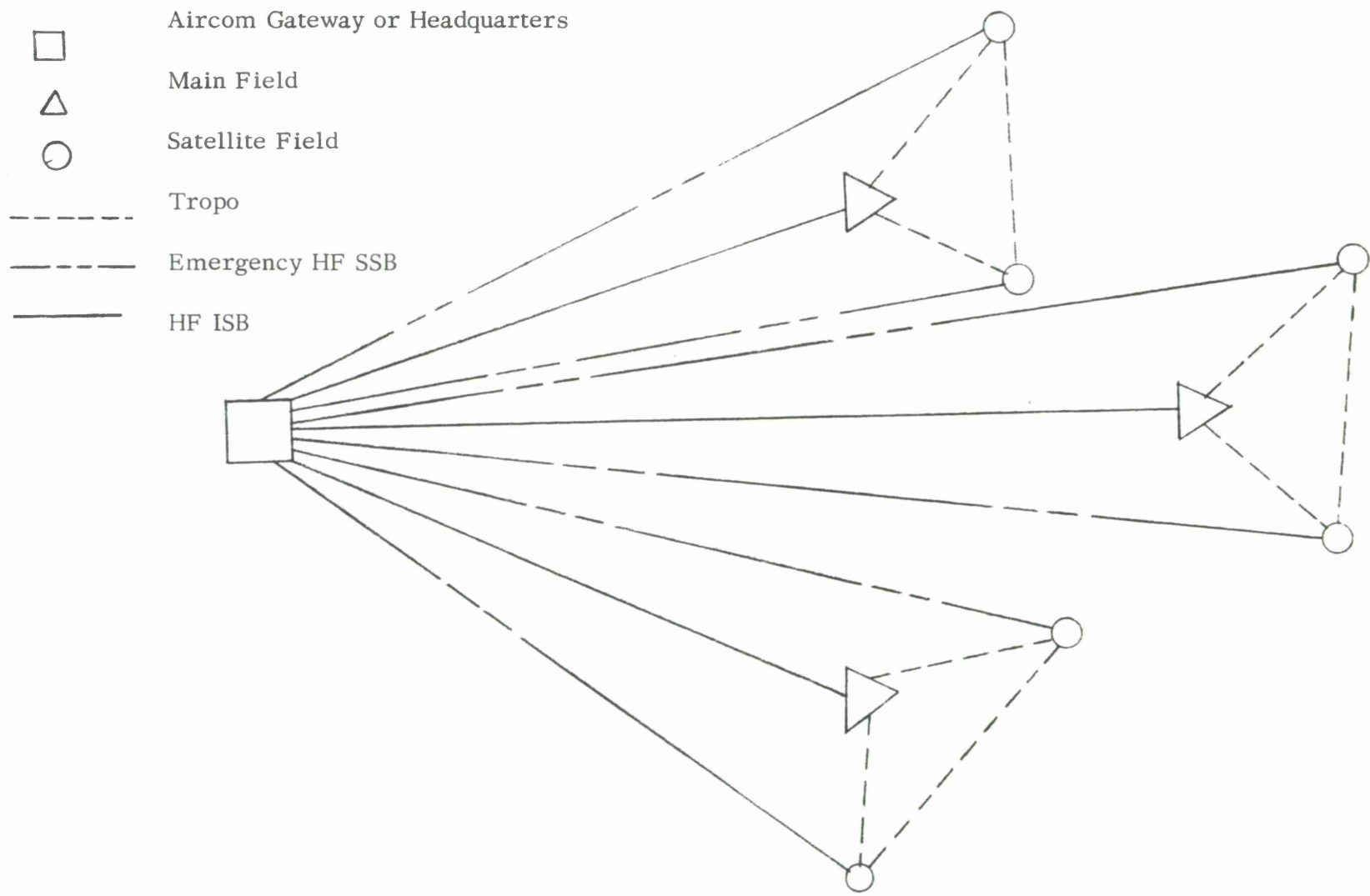

Figure 1. Third Degree Alternate Routed System



7

Figure 2. Recommended Alternate Routing System

- (3) Main field communications follow the same basic pattern except communications to Aircom gateway or headquarters is by HF ISB (Independent Single Sideband). Main airfields will not enter the emergency net, since the principle function of the emergency net is realized when communications with a main field is lost or the main field is destroyed.

#### B. COMMUNICATIONS REQUIREMENTS

The communications requirements of an EMS complex depend primarily on its structure. Present planning indicates a complex of main airfields, each having its own complex of satellite fields, thus adhering to the principle of dispersal of forces as it applies to modern limited warfare. The application of this principle to tactical airfield location indicates a communications complex applying principles of alternate routing through lateral links to assure continuity of communications.

Based on these principles and the expected deployment patterns of EMS systems as exemplified by the selection of equipment characteristics in the AN/TSQ-47 system now under procurement, expected ranges for communications are as follows:

Satellite to Satellite, Lateral	15-80 miles
Satellite to Main, Vertical	15-40 miles
Main to Main, Lateral (not recommended)	80-200 miles
Main to Main, Vertical Routing (Relayed)	400-2600 miles
Main to HQ or Aircom Gateway (as applicable)	200-2000 miles

The ranges involved can be correlated to frequency groups, provided that reliability, susceptibility to ECM, and vulnerability to enemy action is considered. On this foundation, high frequency equipment similar to the equipment of the current AN/TSC-23 provides the most reliable long hop coverage (2000 miles).

High frequency is neither reliable nor particularly ECM resistant between 30 and 200 miles. Below 30 miles, communication on high frequency is generally

reliable, but because of its brute force technique, it is susceptible to monitoring at extremely long distances, thus rendering it dangerous from an intelligence gathering point of view.

Microwave communications must also be ruled out, as well as any other relay type system because of the necessary repeaters (unmanned repeaters are partially practical but present a delivery and reliability problem). Refer to Appendix I, Project Tobacco Can.

Therefore, tactical and propagation considerations indicate the use of LF - MF surface wave propagation for short ranges and UHF/SHF troposcatter propagation for short and intermediate ranges. Refer to Page 12 for a theoretical analysis.

Two types of information transmission are required over these communications links: 100 WPM teletype and 250-3000 cps voice. The most practical and flexible system is to multiplex 42.5 cps FSK teletype into a voice band and multiplex these voice bands for transmission.

Therefore, only one type of channel is needed in the transmission system, teletype multiplexing being done previous to insertion in a transmission channel.

Working on the basis of what has been determined for the AN/TSC-23, and considering the increased load presented by satellite fields, the following channel allocation seems reasonable.

#### Long Range Communications

8 channels, normal; 6 voice, 2 TTY MUX<sup>1</sup>

4 channels, backup<sup>2</sup>; 3 voice, 1 TTY MUX

---

<sup>1</sup> 4 channel TTY MUX is anticipated.

<sup>2</sup> Short range backup is provided by alternate routing.

## Short/Intermediate Range Communications

4-8 channels, normal

3-6 voice, 1-2 TTY MUX

### C. ANALYSIS

#### 1. LF-MF Surface Wave Propagation

Because of its practicality in a tactical environment, horizontal polarization with antennas close to the earth's surface is considered. The transmission path is considered over good soil, (dielectric constant " $\epsilon$ " of 30, conductivity " $\sigma$ " of 0.02) thus leading to somewhat conservative results.

For a plane earth, the attenuation of the transmitted field is expressed by:

$$\frac{\epsilon}{\epsilon_0} = 1 + K e^{j\Delta} + (1-K) A e^{j\Delta} \quad (1)$$

where:

$$\Delta = \frac{4\pi h_o h_a}{XS} \quad (2)$$

$$A = - \frac{1}{1 + j \frac{2\pi S}{\lambda} (\sin \theta + Z)^2} \quad (3)$$

$$Z = \sqrt{\epsilon_0 - \cos^2 \theta} \quad (4)$$

$$\epsilon = \epsilon_{\text{gnd}} - j 60\lambda \sigma_{\text{gnd}} \quad (5)$$

$$K = \frac{\sin \theta - Z}{\sin \theta + Z} \quad (6)$$

At LF and MF,  $\theta$  and  $\Delta$  both approach zero.

Therefore:

$$(1 - K)A \approx \left( \frac{4\pi h_o}{\lambda S} \right)^2 \quad (7)$$

and:

$$h_o = \frac{\lambda}{2\pi Z} \quad (8)$$

Leading to:

$$\frac{\epsilon}{\epsilon_o} = \frac{\lambda}{\pi S [(\epsilon_{\text{gnd}} - 1) - j 60 \lambda \sigma_{\text{gnd}}]} \quad (9)$$

Insertion of the path conditions into (9) yields:

$$\frac{\epsilon}{\epsilon_o} = \frac{\lambda}{\pi S (29 - j 1.2 \lambda)} \quad (10)$$

When the receiving antenna is matched to a 50 ohm line, the input voltage to the receiver is given by:

$$V \Big|_{50 \text{ ohms}} = \frac{\lambda \epsilon}{3.11 \pi} \sqrt{G_A} \quad (11)$$

Over an isotropic path ( $G_A = 1$ ), substitution for " $\epsilon$ " yields:

$$V \Big|_{50 \text{ ohms}} = \frac{0.1783 \lambda^2 \sqrt{W_t}}{S^2 (29 - j 1.2 \lambda)} \quad (12)$$

Equation (12) is then evaluated for the following conditions:

$$W_t = 2 \text{ kilowatts}$$

$$\lambda = 1000 \text{ meters}$$

$$V = 1 \text{ microvolt}$$

(The selection of V yields a 6 db signal-to-noise ratio for a receiver noise figure of 18 db in a 20 kc bandwidth.)

Under these conditions, solving for S, the maximum range is found to be 50.2 statute miles.

## 2. UHF/VHF Tropospheric Propagation

Based on the work of Ortwein, Hopkins, and Pohl (Proc. IRE, April 1961) correlated to the work of Vogelmann, Ryerson, and Bickelhaupt (Proc. IRE, May 1959), an analysis of tropospheric scatter propagation has been developed which will serve for practical calculations in this area.

From Ortwein, et al:

$$Q_N = \frac{N_{mn} a^3 m+n+3 \lambda^{m-2}}{D^{m+2n+2}} \quad (13)$$

Based on an average of the Bolgiano spectrum over the buoyancy and inertial subranges, and assuming  $n = 0$ ,

$$m = 1.5 \quad (14)$$

leading to:

$$Q_n = \frac{N_{mn} a^3 \lambda^{4.5} \lambda^{-1/2}}{D^{3.5}} \quad (15)$$

$N_{mn}$  is evaluated by comparing  $Q_n$  to the computed values in the Vogelmann paper for the conditions cited, leading to:

$$N_{mn} = 2.33 \times 10^{-18}$$

Thus:

$$(Q_N)_{db} = -42.1 + 30 \log \alpha_{deg} + 5 \log f_{mc} - 35 \log D_{sm} \quad (16)$$

When  $Q_N$  is then computed for other conditions, a close agreement with the Vogelmann paper is noted.

#### Symbols

$Q_N$	-----narrowbeam attenuation factor defined by	$\frac{P_R}{P_{FS}} = Q_N$
$P_R$	----- actual received power	
$P_{FS}$	----- received power based only on free space	
$\alpha$	----- average antenna beamwidth	
$D_{SM}$	----- horizon-horizon distance (statute miles)	
$f_{mc}$	----- frequency in Megacycles	

A plot of this equation at constant path length with frequency varying using a 10 foot parabolic antenna has been made and is shown in Figure 3 and 4.

Tropospheric propagation as a result of diffraction over smooth earth has also been studied and is plotted in Figure 5. It is noted that the diffraction field is more highly attenuated than the scattered field by approximately 10 db at 300 Mc and approximately 170 db at 4 GC. This is due to flattening of the scatter slope with increasing frequency.

This effect takes place because of the stronger dependence of  $Q_N$  on the beamwidth,  $\alpha$ , than on frequency alone.

FIGURE 3  
 FREQUENCY DEPENDENCE  
 OF  
 TRANSMITTER PATTS  
 RELATIVE TO FREE SPACE  
 ANTENNA

$$Q_{fs} = -42.1 + 30 \log f + 5 \log f_c - 35 \log D_{fs} \quad (\text{DB})$$

$$Q_{fs} = \frac{N_{fs} \sigma^2 C_{fs} \cos^2 \theta}{D_{fs}^2 (4\pi f_c^2)^2}$$

(RATIO)

BASED ON  
 ASSUMED GALILEO POSITION

$$T_n = 1.5$$

$$T_n = 0$$

$$N_{fs} = 2.33 \times 10^{-18}$$

10 FT PARABOLIC ANTENNA  
 PATH LENGTH = 100 STAT MILES  
 DISTANCE HORIZON TO HORIZON TO STAT MILES  
 $Q_{fs} = \frac{1}{3}$  EARTH RADIUS

RESPONSE IN DB RELATIVE TO FREE SPACE

14

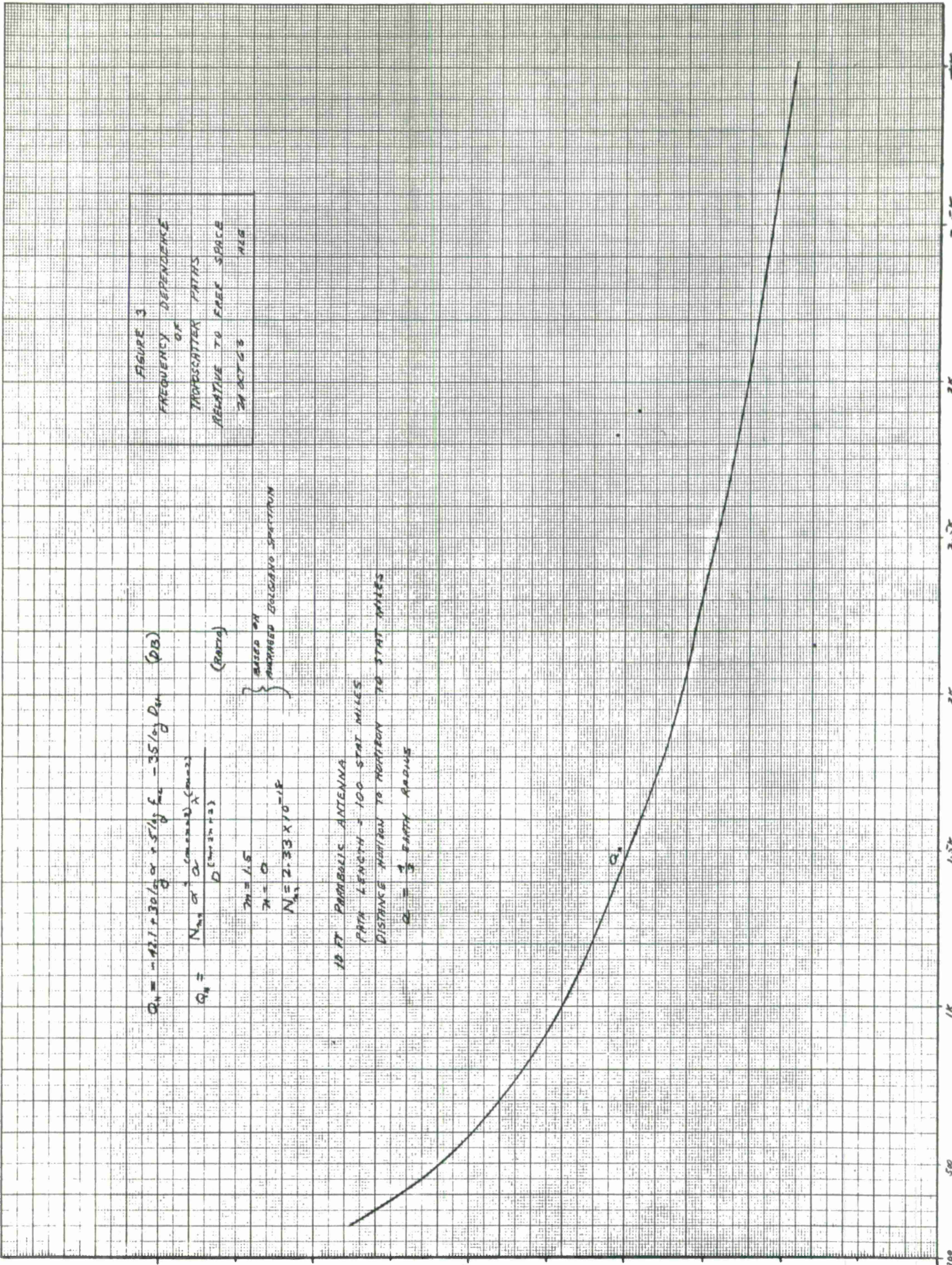

FREQUENCY IN MC

400

350

300

250

200

150

100

50

-90

FIGURE 4.  
 TRANSPONDER PATH RESPONSE  
 USING  
 10 FT PARABOLIC ANTENNAS  
 OVER A 100 MILE PATH  
 PA 07-58 MKG

$A = G_1 + G_2$   
 $G_1 = R + G_{fs}$

PATH RESPONSE IN DB RELATIVE TO TRANSMITTER OUTPUT

SCATTER RESPONSE IN DB RELATIVE TO FREE SPACE

FREE SPACE (G<sub>fs</sub>)

ANTENNA COMPUTED SCATTER RESPONSE (R)

TOTAL PATH RESPONSE (G<sub>T</sub>)

FREQUENCY IN MC

1000  
500

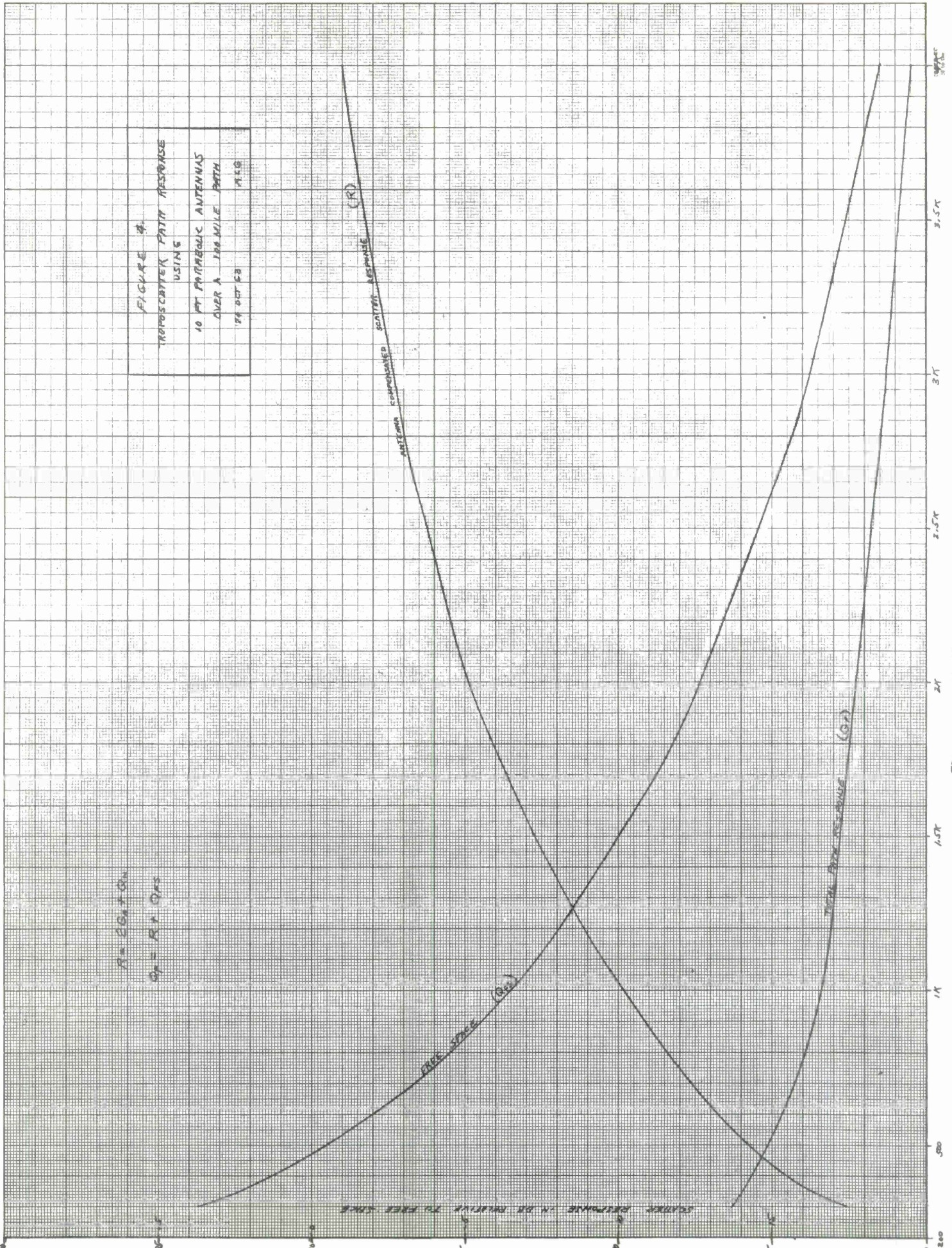
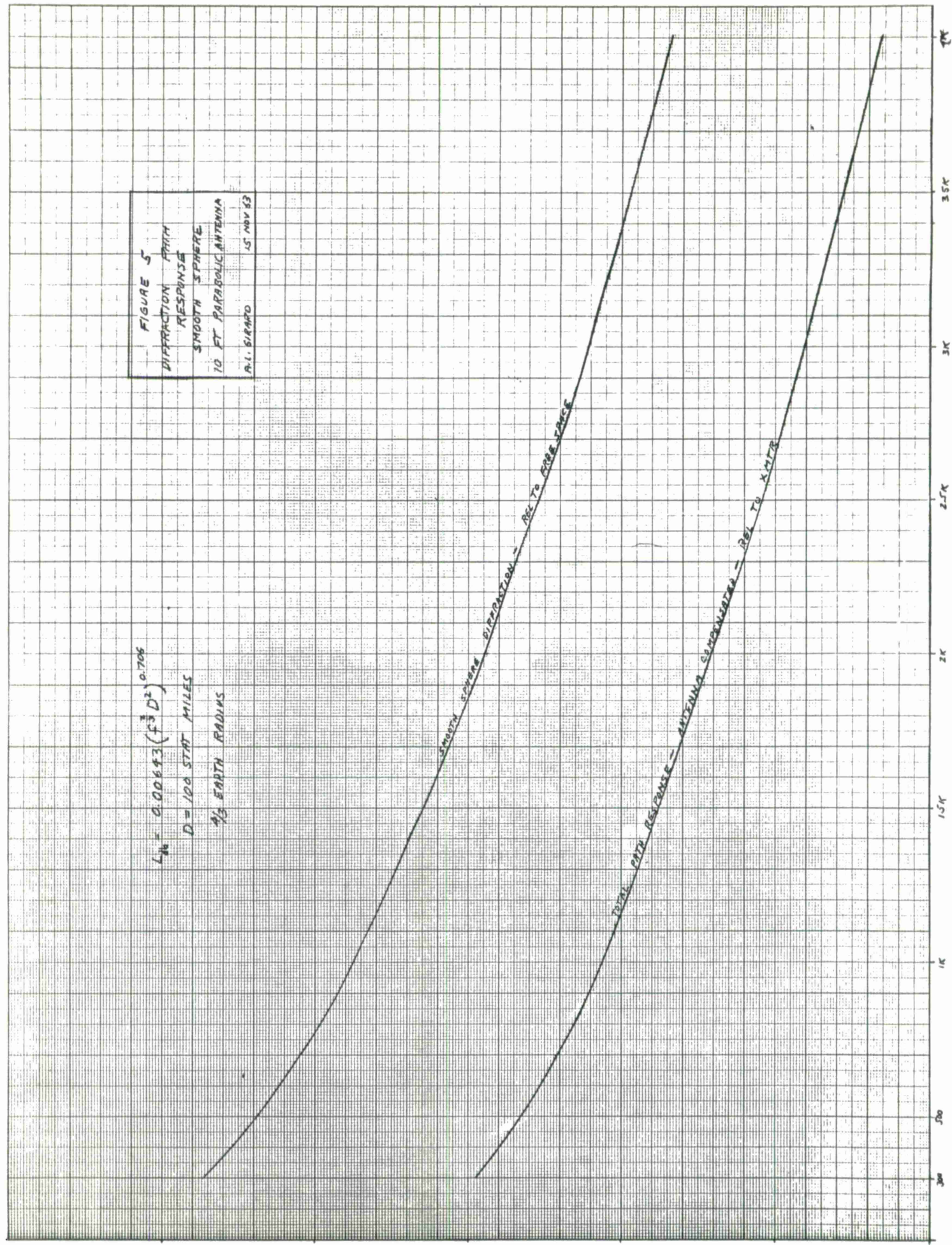

FIGURE 5  
 DIFFRACTION PATH  
 RESPONSE  
 SMOOTH SPHERE  
 10 FT PARABOLIC ANTENNA  
 P.I. SIRARD 15 NOV 63

$L_n = 0.00643 (f^3 D^2)^{0.706}$   
 $D = 100$  STAT MILES  
 $\frac{1}{3}$  EARTH RADIUS

SMOOTH SPHERE DIFFRACTION - REL TO FREE SPACE

TOTAL PATH RESPONSE - ANTENNA COMPONENTS - REL TO X MTR



GAIN IN DB RELATIVE TO FREE SPACE

UNCLASSIFIED

24 OCT 63 RUC

FIGURE 6  
 FREQUENCY DEPENDENCE  
 OF  
 GAIN & BEAMWIDTH  
 FOR  
 10 FT PARABOLIC ANTENNA

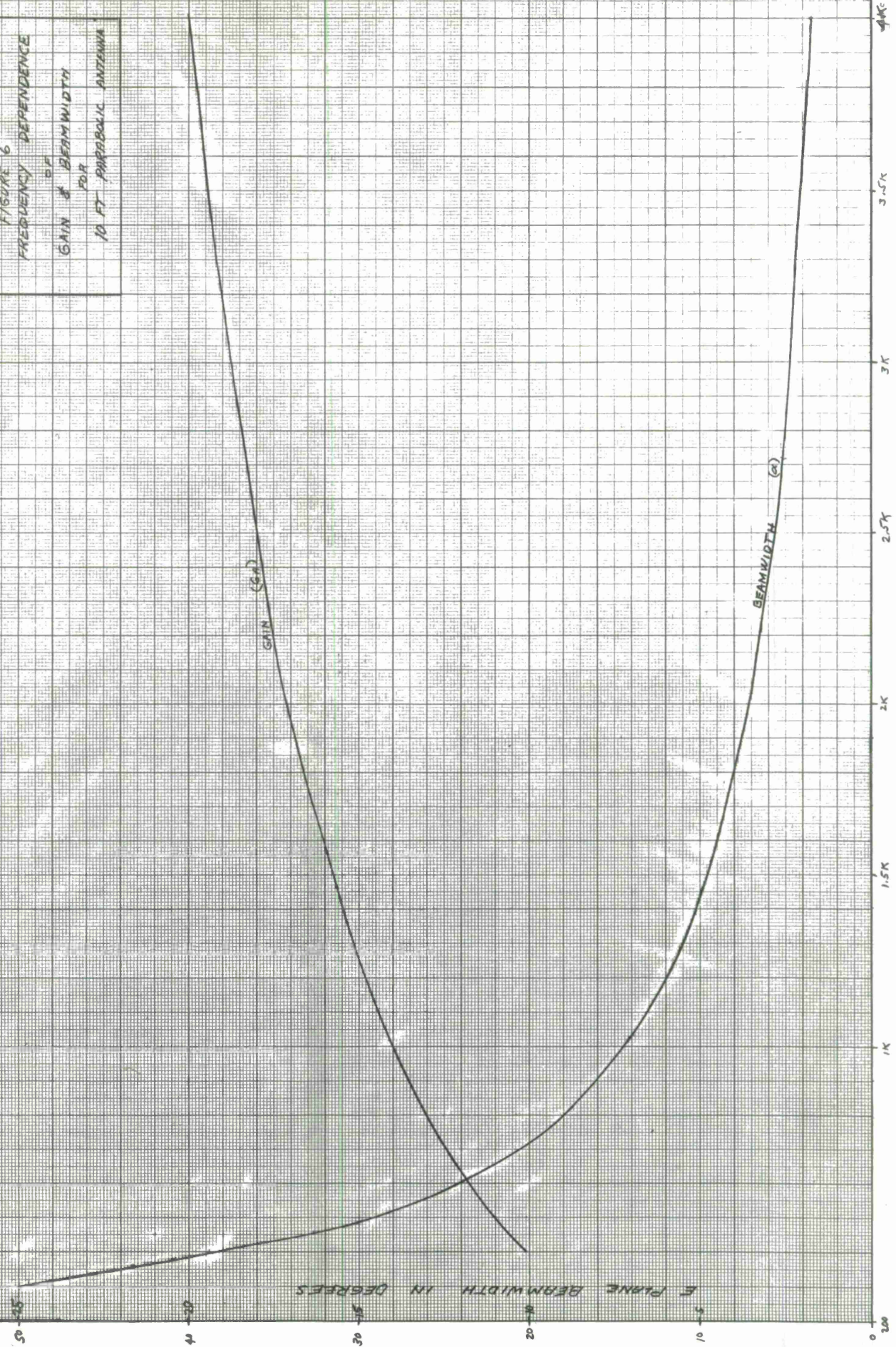

FREQUENCY IN MC

F PLANE BEAMWIDTH IN DEGREES

0.5

0.1

0.2

0.3

0.4

0.5

1K

1.5K

2K

2.5K

3K

3.5K

4K

On the basis of this, the following conclusions are apparent:

(1) The scattered field is more reliable for over-the-horizon transmission than fields diffracted over smooth spheres. Edge diffraction was not considered since it is a function of terrain.

(2) The scattered field strength flattens with frequency at constant path length, thus showing that frequencies from 300 Mc to 4 GC are usable for tropospheric scatter propagation.

(3) For a total path loss of 149.5 db over 100 statute miles at 4 GC, a 1 kw transmitter is needed to provide a 7 microvolt signal to a 50 ohm receiver (-90 dbm) thus resulting in  $\frac{S}{n} = 9$  db if the receiver has a bandwidth of 2 Mc and a noise figure of 12 db. There is no allowable fade margin under these conditions.

### 3. Basis for Recommended Tropo System Specifications

A troposcatter system operating at 4 GC (worst case) has a path loss of 149.5 db from Figure 3. If a 1 kw transmitter is used, and the bandwidth necessary for PPM transmissions on AM is 1 Mc (8 channels and sync, 2 microsecond pulse width, maximum displacement  $\pm 4.9$  microsecond), then, with a receiver noise figure of 3 db, the signal to noise ratio is 21 db.

FM transmission of this bandwidth requires 2 Mc of receiver bandwidth if the modulation index,  $\beta$ , is 2. This figure is chosen in order to maintain the threshold level where FM becomes advantageous at about 10 db signal-to-noise ratio.

Under these conditions, the equivalent AM signal-to-noise ratio is reduced to 18 db because of the increased bandwidth. However, from:

$$\left[ \frac{S_o}{N_o} \right]_{FM} = 3\beta^2 \left[ \frac{S_o}{N_o} \right]_{AM} \quad (17)$$

Then, the improvement is by a factor of 12, or 10.8 db, thus increasing the output signal-to-noise ratio to 28.8 db.

A frequency multiplexed system for 8 channels using the same low noise front end in the receiver and using FM with  $\beta = 2$  will require 200 kc of bandwidth and will have a total signal-to-noise ratio at the discriminator output of 38.8 db, a 10.8 db improvement over an AM system in the same bandwidth, or a 7.8 db improvement over an AM system in a 100 kc bandwidth.

However, PPM provides additional quieting over FM and this quieting is given by:

$$\left[ \frac{S_o}{N_o} \right] = \frac{1}{2} \left[ \frac{t_o}{T_R} \right]^2 \left[ \frac{S_c}{N_c} \right] \quad (18)$$

Thus, the improvement is given in db by:

$$Y = 10 \log \frac{1}{2} \left[ \frac{T_o}{T_R} \right]^2 \quad (19)$$

For the PPM system characteristics listed above, the improvement is by a factor of 12 leading to a total signal-to-noise ratio of 39.6 db.

When the multiplexer circuitry and linearity requirements are considered, noting the comparative output signal-to-noise ratios involved, the FM, PPM system presents the most practical system for the following reasons:

- (1) PPM/TDM circuitry requires simple light weight circuitry, as opposed to the more complex and heavy FDM circuitry.
- (2) PPM/TDM circuitry is repetitious, and therefore, less expensive.
- (3) PPM circuitry is highly stable under environmental conditions because of its primarily digital nature.

## D. SYSTEM DESIGN

### 1. Equipment Selection Criteria

The equipment selected and the configuration in which it is placed must follow closely the requirements of the alternately routed communications plan. In this manner, compatibility of the system with the tactical plan is assured. On this basis, then, equipment is selected against the following criteria:

Anticipated maximum and minimum path lengths.

Transportability requirements.

Anticipated traffic flow.

Interference.

The first of these criteria is used to determine the operating frequency bands and modulation systems most likely to give optimum service, while the second criterion places definite size and weight limits on the equipment under consideration.

The anticipated traffic flow provides a measure of channel requirements both in terms of number and of type, thus leading to a conception of multiplexer complexity.

Interference with other equipment or from other equipment is a serious problem in a tactical system, and therefore, analysis of frequency allocation and modulation techniques is mandatory in the selection of equipment.

### 2. System Description

On the basis of the criteria enumerated in the section above, a system design has been established. This system is divided into two complexes following the basic communications plan, one complex being particularly applicable to main field operations, the other being applicable to Satellite field operations.

Referring to Figure 2, it is seen that each satellite field comcenter requires a minimum of two short-intermediate range links if the number of satellite fields

is restricted to two per main field. If the number of satellite fields exceeds this, each satellite field requires a maximum of three links - one lateral to each of the two nearest satellite fields and one vertical to the main field.

On the basis of these requirements, the Satellite Field Radio Terminal Van must contain a minimum of three duplex radio terminal equipment backed up by a half-duplex 6 kc ISB HF transceiver. A block diagram of this van is shown in Figure 7.

The basic system for use at a main field currently associated with the AN/TSQ-47 system is the AN/TSC-23. This equipment provides a maximum of 12 voice channels (10 telephone, 2 multiplexed teletype) for use vertically to the rear. When satellite fields are used, this equipment at the main field must be supplemented by short-intermediate range link equipment for vertical use forward to the satellite fields, and must be compatible with the satellite field equipment.

Therefore, the main field radio terminal van must contain a minimum of three 12 kc ISB HF transmitters, three 12 kc ISB receivers, and two duplex radio terminal equipments. A block diagram of this van is shown in Figure 8.

The addition of a satellite field radio terminal van to the main field complex increases the communications capability from a maximum of two satellite fields to a maximum of five satellite fields.

The communications center van is common equipment either to satellite field or main field, and provides clear text and encrypted teletype facilities, as well as telephone switching on any outgoing trunk circuit. The design shown in Figure 9 will handle simultaneously one Main Field Radio Terminal Van and one Satellite Field Radio Terminal Van. The planned deployment is, then, one comcenter van per main field, and one comcenter van per satellite field.

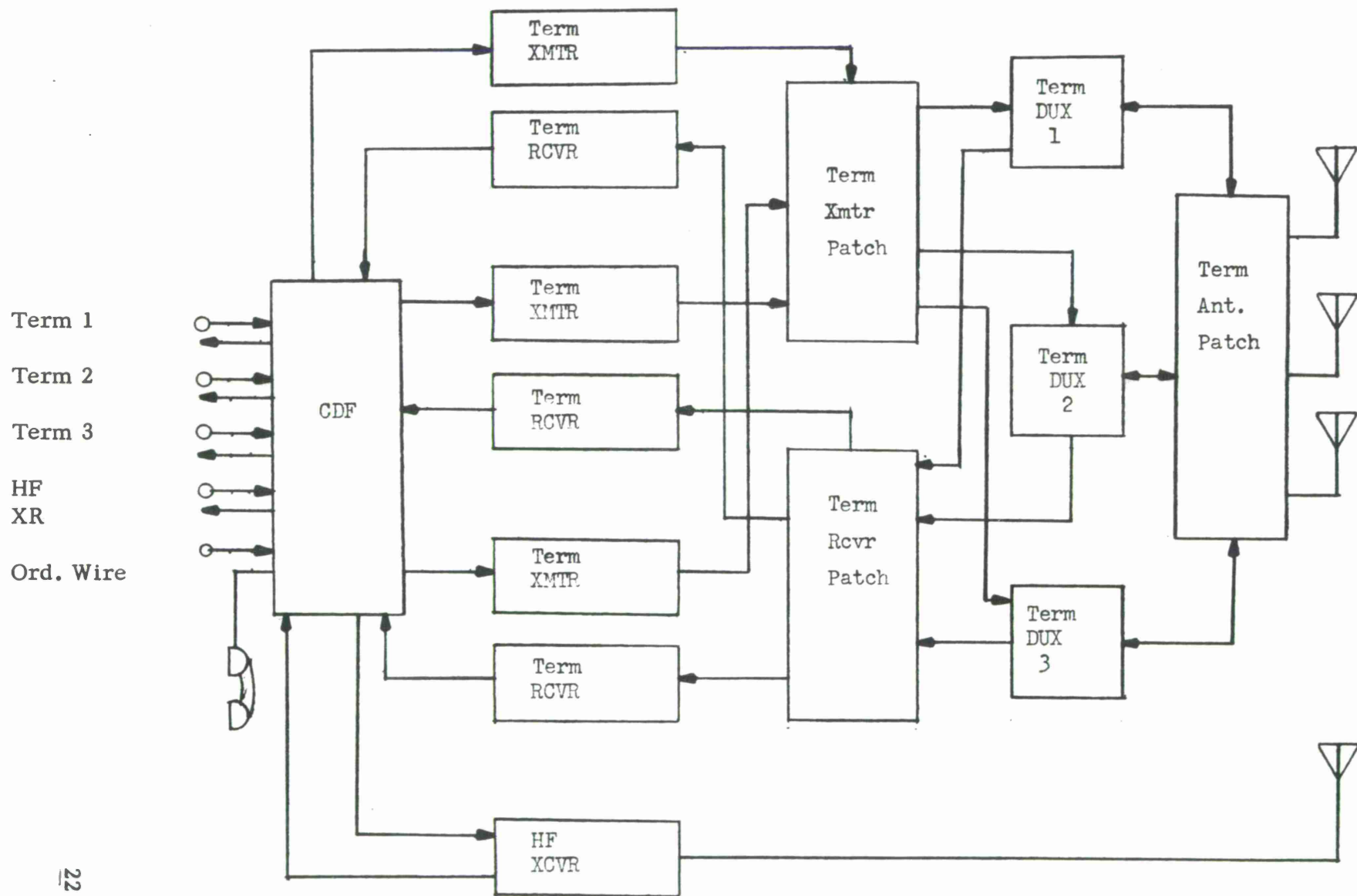

Figure 7. Block Diagram - Satellite Field Communications

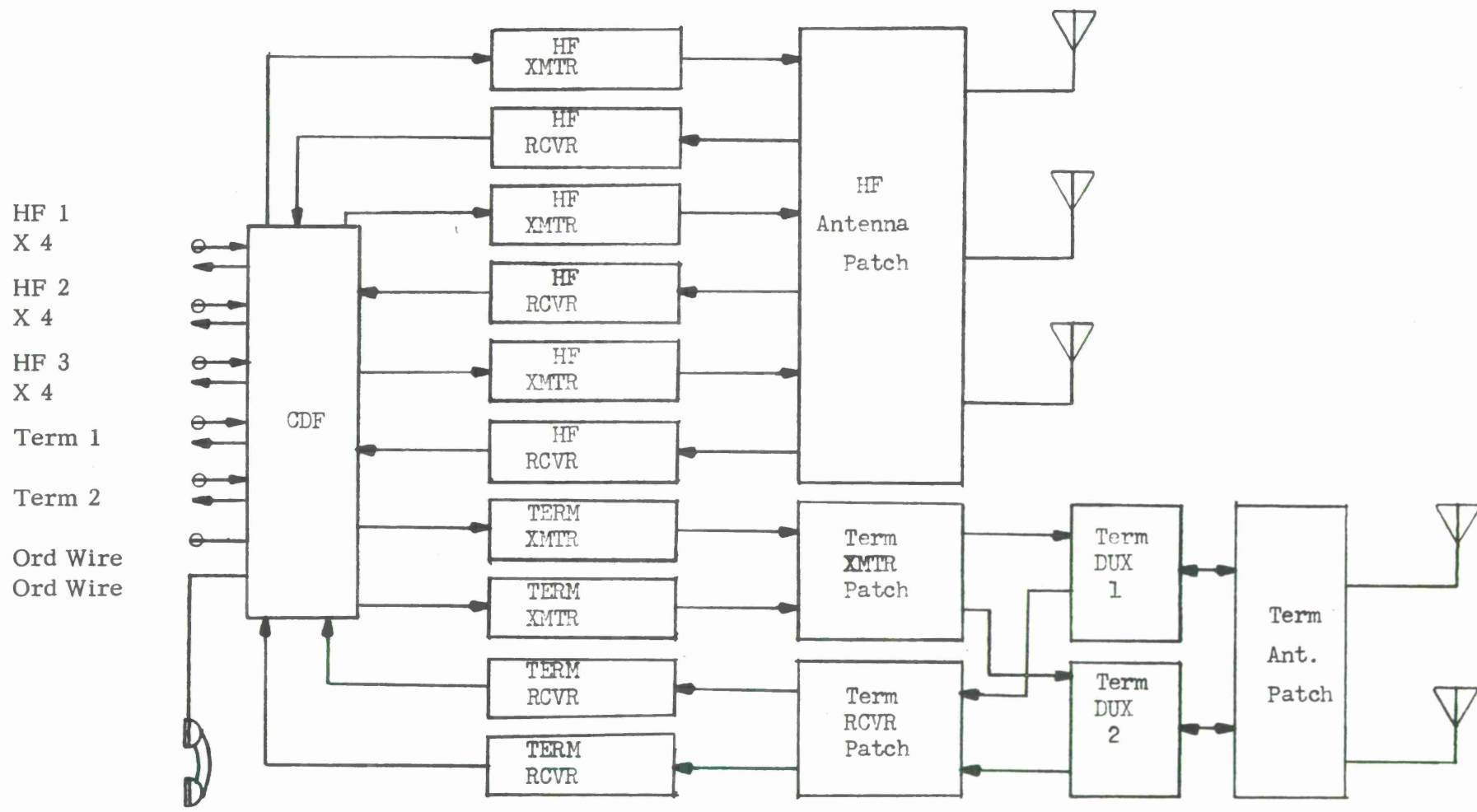

Figure 8. Block Diagram - Main Airfield Communications

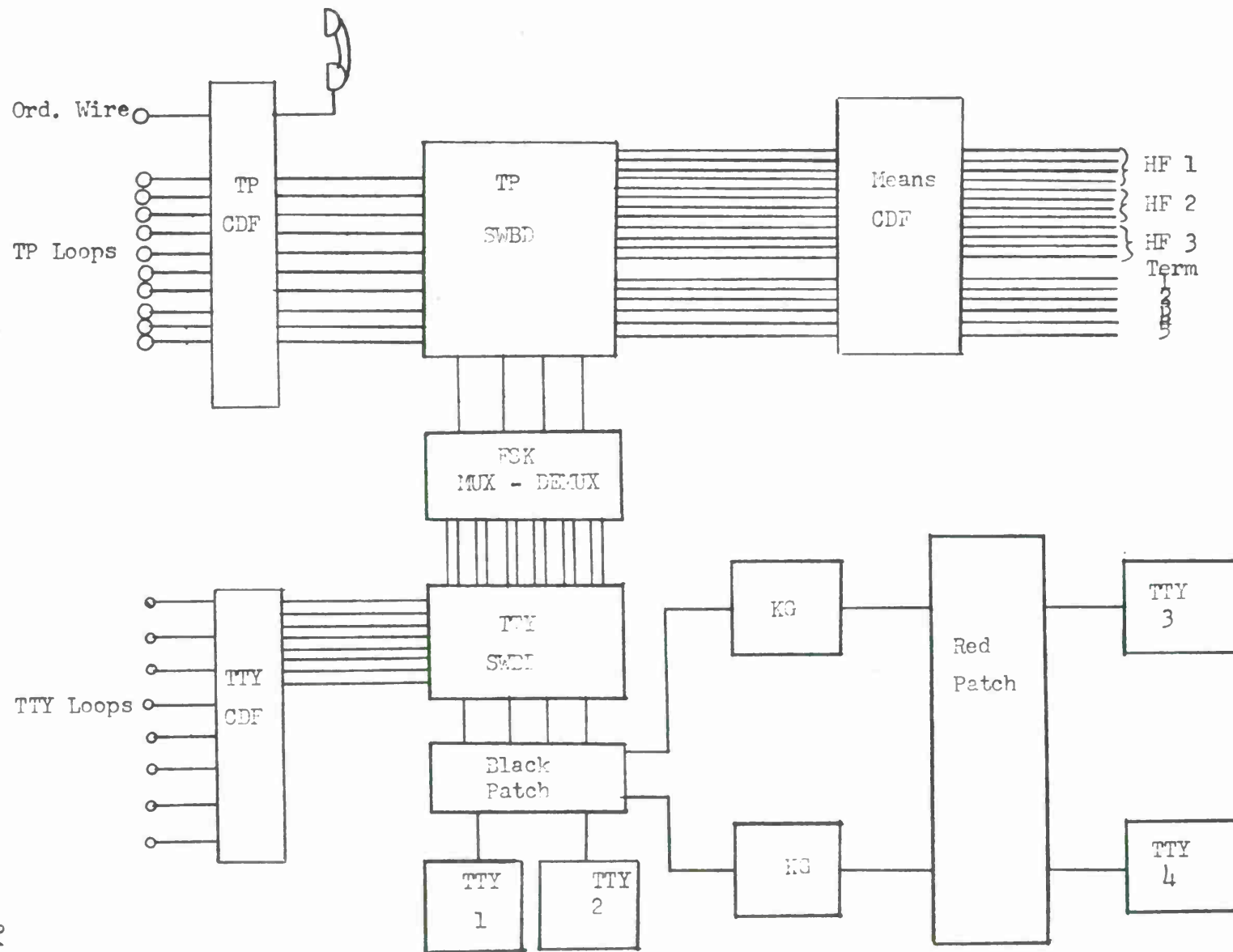

Figure 9. Block Diagram - Comcenter

## E. CONCLUSIONS

The alternate routed system illustrated in Figure 2 presents the best solution to the tactical communications problem from the standpoints of communication reliability and of economy of personnel and equipment.

Tropospheric scatter, on the basis of the above propagation studies, is the most reliable method for communicating over 15 to 200 mile path lengths. Below 15 miles over flat terrain the same equipment can be used as single hop radio relay. In hilly terrain selection of transmitter-receiver sites and use of smooth sphere and edge diffraction will extend this single hop range by as much as 5 to 10 miles.

When path lengths exceed 200 miles, the troposcatter technique is considered unreliable. The HF equipment provides better and more reliable propagation.

A two van configuration at each terminal is indicated both by the amount of equipment involved in a system of this type, and by the experience gathered in observing the AN/TSC-23.

## F. RECOMMENDATIONS

The following recommendations toward the design of a tactical communications center for generalized EMS application are made:

- (1) It is recommended that the communications system be built around the basic plan of Figure 2.
- (2) It is recommended that the main field communications complex consist of two vans conforming to the system designs of Figures 8 and 9.
- (3) It is recommended that the satellite field communications complex consist of two vans conforming to the system designs of Figures 7 and 9.
- (4) It is recommended that the terminal equipment of Figures 7 and 8 utilize tropospheric scatter equipment having the following specifications:

- (a) Frequency Range: 300-900 Mc
- (b) Receiver Bandwidth: 2 Mc Max @ 3 db point
- (c) Transmitter Output Power: 1 kw
- (d) Baseband Modulation: Frequency Modulation
- (e) Multiplexing: Synchronous Time Division Multiplex
- (f) Pre-Multiplex Modulation: Pulse Position Modulation
- (g) Multiplexed Voice Channels: 4-8
- (h) Receiver Noise Figure: 3 db
- (i) Receiver Sensitivity: 3 microvolts for 10 db  $\frac{S + N}{N}$
- (j) Antenna: 10 ft. Parabolic, Collapsible

(5) On the basis of these specifications, it is recommended that the receiver for the troposcatter system incorporate parametric amplifier techniques.

(6) It is recommended that the output of the exciter for the 1 kw transmitter be approximately 5 watts and incorporate provisions for direct coupling to the antenna by-passing the power amplifier in order to provide low power single hop radio relay links.

## II. TACTICAL HIGH FREQUENCY DIRECTIVE ANTENNA

### A. STATEMENT OF WORK

This portion of the work statement involves the HF log-periodic monopole antenna presently being utilized by the Air Force in conjunction with their communications central, AN/TSC-23, to provide long range, point-to-point communications. In compliance with the work statement, it has been the prime purpose of this report to come up with an HF broadband, unidirectional antenna that will have a minimum of bulk, weight, and erection time. This antenna will be the most advantageous choice with respect to cost, capability and availability. It has been the secondary purpose of this report to come up with techniques which might enhance the miniaturization and/or erection time, of course without compromising other portions of the antenna specification, through continued development efforts in the field of antenna design.

In arriving at a solution to the problem, these approaches were made:

(1) The miniaturization and decrease in erection time of the present log-periodic antenna through an investigation in the following areas:

- (a) The time consuming elements in the erection procedure.
- (b) The application of suitable loading techniques.
- (c) The redesign of certain log-periodic parameters.

(2) The miniaturization and decrease in erection time through purchase of less cumbersome, off-the-shelf hardware.

(3) The miniaturization and decrease in erection time, through further development of state-of-the-art techniques.

### B. MINIATURIZATION THROUGH RECONSTRUCTION OF PRESENT LOG-PERIODIC

#### 1. Erection Procedures

Discussing the first area of the first approach, a careful time log on the erection of the log-periodic antenna was taken during recent tests at Michell

AFB. This time log showed that the major time consuming portions of the erection was in the insertion of the anchors into the terrain and the fixing of the main mast, including guy wire tension adjustment. These two jobs consumed approximately 21 man hours each (7 men, 3 hours), totalling 42 man hours, while the entire antenna erection consumed 52.5 man hours (the specification calls for 6 men in 4 hours to erect fully the antenna). It appeared that these two activities would be the prime areas for cutting corners in the time of erection. First, types of masts were investigated, such as, telescoping pneumatic, telescoping elevator, elevator sectional and telescoping cable. In conclusion, none of these showed any decisive advantage in decreasing the erection time. The number of guy wires could not be decreased and it became apparent that the height of the mast was our main concern. This led, as will be discussed later, to an investigation of loading techniques for the lessening of the requirement for mast height.

Secondly, the problem of ground anchor insertion was investigated. Two considerations evolved here: the type of anchor and the driving of the anchor into the ground. An arrow head anchor is available that can be easily hammered into the ground instead of being tediously turned into the ground, as the present cork-screw arrangement now exists. Of course, a power auger may be obtained for the cork-screw ground anchor, but this arrangement would require a much heavier tool kit and ancillary power equipment. Therefore, if this antenna continues to be utilized, the quick communication capability desired by this system will be greatly enhanced by converting over to the arrow head ground anchor (at least the arrow head should warrant a trial run). A point worth mentioning is the operation of the arrow head. After it is driven into the ground, and a pulling force is exerted, it will assume a position that will place the plane of the arrow face perpendicular to the force, hence offering maximum resistance. For tactical, quick disassembly reaction, these arrowheads could be dispensed with and left in the ground, or using a wire, which is attached to the anchor during insertion, the arrow head may be adjusted to assume an angle for easy extraction.

## 2. Loading Techniques (RF)

A number of techniques for RF loading of antenna elements were investigated with the goal of reducing element size, weight, and moreover, mast height.

The use of corrugated lines or the compressing of more line length in the same package was considered. This was found to reduce the effectiveness of the radiation pattern. This wrinkling effect of a dipole element produced spurious radiation and established considerable diffraction nulls within the pattern.

Another loading technique is the use of a dielectric medium surrounding a dipole element. This technique would effectively reduce the velocity of the electromagnetic wave by the square root of the dielectric constant of the medium. With the frequency remaining constant, and the velocity of the wave decreased, the wavelength of the wave is effectively reduced and, hence, the length of the half-wave antenna required is also materially reduced by the square root of the dielectric constant. The problem with this technique is that the mass of the dielectric required for use in the HF band is too great (the diameter of each element becomes appreciatively larger although the element height is decreased).

A third technique will utilize the resonant frequency and wavelength of a dipole element. This technique provides loading coils to increase the effective inductance of a dipole element, and consequently reducing the resonant frequency of the element. This in turn increases the virtual height of the antenna and allows it to accept frequencies lower than that when unloaded.

This is a feasible and widely accepted technique for most applications, that is, if enough power is available to offset the loss in radiating efficiency produced by utilizing loading coils. The problem with our application is that we are utilizing a log periodic antenna and not a simple dipole element. Although the log periodic can be assumed to be made up of a number of monopole elements (utilizing the ground for its image), its operation, per se, does not readily lend itself to inductive loading. By inductively loading, the radiation resistance of an element

decreases, allowing an increase in the Q of the element. In a log-periodic antenna, the bandwidth (and the gain) of an active region is inversely proportional to the Q of the elements of the active region and consequently, as the Q is increased, the bandwidth of an active region will be decreased. If the bandwidth of each active region is subsequently decreased, there will be a number of discontinuities existing in the radiation pattern over the wide band of log periodic operation (4-30 Mc). Effectively, a wide band antenna would no longer exist and a degradation in gain would also appear. The impedance of the antenna would effectively remain the same. However, an important consideration is that more antenna elements may be added within an active region to smooth out the discontinuities in the radiation pattern and produce a wide band device once again. The drawback of this feature is, with the addition of more in-line elements, a longer antenna array will exist and a greater ground area will be required. In conclusion, this loading technique would be feasible with additional ground area.

Still another loading technique is the utilization of ferrites. This is very closely related to inductive loading in that a ferrite is just the addition of a suitable core element within the inductor, increasing flux concentration and inductance. A suitable ferrite material should be selected if the loading coil technique is utilized.

The last technique investigated is capacitive or top hat loading of the individual elements. This increases the capacitance of each element and like inductive loading, this too will decrease the resonant frequency of an element, and allow a lower frequency to be utilized for a given cut element. The problem with this technique is that there will be a definite mechanical disadvantage in erection and ice and wind loading.

### 3. Redesign of Log-Periodic Parameters

The third area of the first approach is the re-evaluation of various log-periodic design parameters. The highest element is an unloaded log-periodic antenna (without a ground plane) will have to be in the order of  $1/2$  of a wavelength.

It is around this lowest frequency element that the antenna is designed. Therefore, given a low frequency restriction, the nature of a log-periodic antenna does not lend itself to the trading off of parameters, to reduce the longest element. Although the beamwidth, gain, bandwidth of an active region, and impedance of the log periodic may be varied by reshuffling of the parameters, there will be no ultimate reduction in the height of the log periodic.

### C. MINIATURIZATION THROUGH PURCHASE OF OFF-THE-SHELF HARDWARE

#### 1. Areas Contacted

In discussing the second approach, or the miniaturization and decrease in erection time through purchase of off-the-shelf hardware, a number of contacts were made. Antenna manufacturers, government agencies at Fort Monmouth, New Jersey, and Bedford, Massachusetts, along with educational institutions, were either visited or corresponded with. A number of ASTIA documents and IRE publications were researched for applicable data. A list of all contacts are included in Section IV.

#### 2. Selection of Appropriate Antenna

A number of available antennas were first selected for their bandwidth characteristics. It was proposed to cover the bandwidth requirements of the log periodic with either one suitable antenna, or if the erection time could be enhanced, even two antennas, each covering a portion of the total bandwidth requirement. As this latter attempt did not prove successful, data on those antennas that could meet the requirements individually was tabulated and will be submitted as Table 1.

A number of those antennas presented in Table 1 were found to be not suitable for tactical EMS operation. The information is included only to provide a comprehensive and up to date listing. Some of the antennas have been in final development stages of testing and evaluation and after further discussions with the manufacturers, these too fail to meet the necessary requirements.

One case in particular is the Granger Model 770. This antenna appeared to be the most suitable design until late in the program deficiencies showed up during field tests. The manufacturer could not confirm the original specification, therefore, it is now considered not feasible for EMS use. The condition could, and most likely will, change as the manufacturer corrects deficiencies and improves the design, but this is not considered for this report.

Of the remaining antennas, two appear to be suitable and available for EMS application. These two are the Granger 747CA and the All Products Company (APC) LPH-3C. Considering cost, capability, and availability, both have the same availability, both will provide the communication link required, but although the Granger 747CA is lighter by 163 pounds, shorter in height by 11 feet, and less in the length of the area required by 110 feet, it has a higher VSWR and costs \$4,300 more than the LPH-3C. It will be the decision of the user as to whether the added miniaturization afforded by Granger will be worth the additional cost.

### 3. Justification of Promising Antenna Specifications

To justify the specifications of the proposed antennas, reference will be continually made to the data in Table 1. A comparison can readily be made with the applicable military specification.

The LPH-3C has a power handling capability of 3.5 kw average and the 747CA has a power handling capability of 5 kw average. Two HF transmitters may be used with each log-periodic antenna at any one time. Since each transmitter is capable of producing 500 watts average power, then a minimum power requirement for the antenna becomes 1000 watts average. This requirement is more than adequately covered by both antennas.

Referring to the list of antenna characteristics, the bandwidth, input impedance, VSWR, and minimum gain figures of both antennas meet the specifications. The antenna height, weight, volume and area required for erection provide an approach to miniaturization. These antennas do not meet the requirements for wind and ice loading, as specified.

TABLE 1. TRANSPORTABLE HF ANTENNA CHARACTERISTICS

Mfr. Char.	Spec.	Andrew	Granger	Granger	Andrew	Andrew	All Prod.	All Prod.	Collins	Collins
Model		LM 26969	770	747 CA	25151	3701	LPH-3	LPV 630-T	637E-1	637B-1A
Freq/mc	4-29.99	3-30	4-30	4-30	4-24	6.5-60	4-32	6-30	3-30	6.5-30
Z <sub>o</sub> /ohms	50	50	50/balun	50/300	75		50/70	50	50/balun	50
VSWR	2:1	2:1	2:1	2:1	2:1	2.25:1	1.6:1	2.5:1	2.5:1	2:1
Polariz.	Vert	Vert	Hor	Hor	Hor	Hor	Hor	Vert	Hor	Hor
Fr-Bk/db			14	14			14	15		
Directiv.	Cardioid	Cardioid		Lobe			Lobe		Lobe	Lobe
Gain/db	9	7	14	14			14	15	11	12
Pwr/kw	1 ave	2.5 pep	3 ave	5 ave	40 pep	40 pep	3.5 ave	5 pep	10 pep	10 pep
H/ft	100	100	60	75	100	100	86	55	70	53
L/ft	447		138	180			71		240	90
W/ft	355		257	303			59		250	135
Wt/lbs	2000	1420	115	535		1500	698	935	850	1200
Vol/ft <sup>3</sup>	270	23	75					52.5	60	100
Wind/kts	100		80	100	100	80	100	75	70	52
Ice/kts	1"/44	1"/44	1/4"/45	1"/50			1/2"/60	1/4"/30		
Az BW/deg	110	110	60	60	60	60	50-70	90-100	60	65
E1 BW/deg	39	Freq Dep	Freq Dep	Freq Dep	60		Freq Dep	30	Freq Dep	Freq Dep
Erection	6men 4hr	4men 2hr	2men 1hr	5men 2hr			6men 2hr	6men 2hr	5men 2hr w/o anch	2men 3hr

TABLE 2. HF ANTENNA CHARACTERISTICS

Mfr. Char.	Granger	Granger	Granger	Granger	Granger	Granger
Model	726-3.5	726-2.5	757-3	757-4	747 V	747-2.5
Freq/mc	3.5-32	2.5-32	3-32	4-32	3-32	2.5-30
Z <sub>0</sub> /ohms	50	50	50	50	50	50
VSWR	2:1	2:1	2:1	2:1	2.4:1	2:1
Polariz.	Vert	Vert	Vert	Vert	Vert	Hor
Fr-Bk/db			14	14	14	
Directiv.	Cardioid	Cardioid				Lobe
Gain/db	10	10	11	11	12	10.2
Pwr/kw	20 pep	20 pep	20 pep	20 pep	30 pep	10 pep
H/ft	100	140	140	100	220	140
L/ft	335	430	620	500	486	260
W/ft	300	420	620	500	320	171
Wt/lbs	4000	6000	12000	7600	8814	8000
Vol/ft <sup>3</sup>	380	450	1080	435	1730	1972
Wind/kts	120	120	120	120	120	120
Ice/kts	1-1/2"/50	1-1/2"/50	1-1/2"/50	1-1/2"/50	1/2"/100	1"/50
Az BW/deg	110	110	110	110	110	60
El BW/deg	30	30	30	30	22	50
Erection	5men 10day	5men 10day	5men 12day	5men 12day	5men 9day	5men 9day

SPECIAL COMMENTS REGARDING  
PARTICULAR HF ANTENNAS

Granger

726-3.5/32	Fixed Installation, Ground Screen Required
726-2.5/32	Fixed Installation, Ground Screen Required
757-3/32	Fixed Installation, Ground Screen Required
757-4/32	Fixed Installation, Ground Screen Required
747 V	Fixed Installation
747-2.5/30	Fixed Installation
770	Specification Preliminary, Tested, Not Feasible
747 CA	10 kw pep, Steerable, Mechanical Fuse for Ice Loading, Cost: \$9640, Availability: 90 Days, Kit for 2 mc in Development, Erection: 5 men 1-1/2 hours for specially trained crew

Andrew

25151	Three Towers to Erect
-------	-----------------------

All Products

LPH-3	Steerable, Cost: \$4950 (LPH-3A)- \$5338 (LPH-3C), Availability: 60-90 Days
-------	---

Collins

637E-1	Complete MIL Approved, Three Towers to Erect
637B-1A	Electrically Steerable, Electrically Raised

Some sort of environmental test will have to be performed to see if the materials of 6061 aluminum, phosphor bronze, synthetic fiber, fiberglass and reinforced plastic will meet the corrosion requirements of the mil. spec.

The directionality of the LPH-3C and 747CA radiation patterns differ from the mil. spec., but the increase in directionality, that is inherent with them, will cut down on interference even more so than the prescribed cardioid radiation pattern. The azimuth beamwidth also lends itself to this argument, in that it is narrower than the specification and remains relatively constant over the entire bandwidth.

As for justifying the reverse in polarization from vertical to horizontal, the following considerations should uphold the reversal. Initially, it was believed that a double boom construction for a horizontally polarized antenna would be physically more cumbersome and require more time for erection than the simple, single boom, vertically polarized antenna. This factor was the main argument against the possibility of using a horizontally polarized antenna configuration for the tactical point-to-point communications instead of using the recommended vertically polarized configuration. However, with single boom techniques utilized by APC and Granger on their horizontally polarized antennas, the argument no longer exists, and the horizontally polarized antenna now appears to be quite feasible for our tactical application of quick erection time with low bulk and weight.

Moreover, horizontal polarization is more advantageous in that it will suffer less attenuation than vertical polarization when antennas are located in fairly dense forest areas (in very dense forest areas transmission will not be good for either polarization). Small changes in antenna location or antenna position among trees (or even at the edge of forests) will cause relatively large changes in the field intensity and upset the standing wave ratio of vertically polarized waves while horizontally polarized waves are affected to a lesser degree.

Also, horizontally polarized antennas are less apt to pick up man made interference which is ordinarily vertically polarized.

On the other hand, vertical polarization is less subject than horizontal polarization to variations in received field intensity, caused by reflections from aircraft flying over the transmission path. This is of importance in locations where aircraft traffic density is heavy.

Beyond these advantages and disadvantages stated, there does not appear to be any other argument for utilization of one type of polarization over the other. Of course, there will be greater ground losses with a vertically polarized ground wave than with a horizontally polarized one, but this will not affect our polarization argument, in that we are not utilizing the ground wave for out point-to-point communications but are utilizing the sky wave, for which ground losses have little effect. Any ground wave transmission that may be necessary, of course, will be performed by the available and vertically polarized whip antennas.

Another point that should be mentioned is that no matter which polarization is utilized, the transmission losses will be the same and there will be polarization rotation for either type. For this sky wave, the free space attenuation and ionospheric absorption loss will be the same for either polarization. Free space attenuation will be dependent on the frequency of operation and transmission distance. Ionospheric absorption loss will be dependent on the electron density and angle of incidence in the various ionospheric layers of the atmosphere.

The density of the electrons in a layer is dependent on the time of day, day of the month, month of the year, and year of the sun spot cycle. Consequently, with the more or less random nature of the density of any ionized layer with time, then it can only be said that any wavefront entering the ionosphere with a specific polarization can only be refracted randomly and certainly leave the ionosphere with some rotation of polarization. An interesting point is that a horizontally polarized rhombic antenna is presently being utilized by most Air Force gateway stations.

It can be concluded that rotation of polarization will result during HF sky wave transmission. This rotation is an unpredictable quantity due to the random

electron densities of the ionosphere. In that the only time that is impossible to establish communications is when the polarization of the received wave is cross polarized (field intensity vectors  $90^\circ$  out of phase) with the polarization of the receiving antenna, and statistically the random rotation of the wave through the ionosphere will be  $90^\circ$  very infrequently, then it is safe to justify the substitution of a horizontally polarized antenna with a vertically polarized one. We will not suffer any greater degradation of received signal level than if the polarization at both ends of the transmission path started out complimentary to each other.

Returning to the justification of the difference in the specification of the LPH-3C, the 747CA and the system specification, it need only be mentioned that the proposed erection times, 12 man hours for the LPH-3C and 10 man hours for the 747CA, are far more desirable than the current antenna erection time of 52.5 man hours or the system specification erection time of 24 man hours.

Our next concern will be in justifying the elevation data presented by these antennas. In that the system specification appears ambiguous in its present form, it will be our purpose here to show that the frequency dependent beamwidths and take-off angles of the antennas proposed, will provide the range of communications required by the Air Force, effectively, 400-2000 miles.

HF propagation is unpredictable; that is, at a given latitude, at a given time, on a given day, of a given month, in a given year within a sun spot cycle, there is a random nature in both the electron densities and virtual heights of the ionospheric layers, and it is these random characteristics of the layers that determine the span of communications for any HF sky wave system. Along with the randomness of the ionosphere, we have the variations in antenna elevation angle and elevation beamwidth, dependent on the frequency selected for transmission, and this comprises a multitude of parameters from which some HF propagation prediction must arise.

A number of techniques are available for predicting sky wave propagation, one of which is presented herein.

Utilizing data made available by the National Bureau of Standards, Charts 1 and 2 were constructed. Test data had been taken by the Bureau, during periods of low sun spot activity, on the variation in electron density within the layers of the ionosphere. They have also determined the virtual heights of these layers as they change with time. With this data available, and by utilizing an equation, in part derived from Snell's Law, it was possible to first predict maximum usable frequencies, Chart 3, and then span of communications, Chart 4.

The formula, represented by Chart 3, takes into account the three parameters, Frequency "F", angle of incidence " $\alpha$ ", and electron density "N", that will determine the return to earth of an electromagnetic sky wave. Using theory developed by Snell's Law, the electromagnetic wave upon entrance into the ionosphere will undergo a series of successive refractions tending to bend the wave around and back to earth. If the wave utilizing a given frequency does not meet its complimentary ionospheric layer at the proper angle of incidence, then the wave will not be returned to earth but will be lost into space.

With the maximum usable frequencies (MUF), as a function of electron density and angle of incidence, the techniques for HF propagation prediction, then entails the location of the characteristic layer that will provide the electron density required in Chart 3 for returning the wave back to earth. The information represented in Charts 1 and 2 is used to determine the virtual height of this characteristic layer. Now, if the virtual height of the layer is known, and, by choice of a suitable frequency, the elevation beamwidth and take-off angle of the antenna becomes known, it then is a simple geometric problem to determine the span of communications that will be established by a single hop transmission path with at least 3 db of power transmitted.

EXPERIMENTAL DATA TAKEN ON THE AVERAGE  
ELECTRON DENSITY OF THE VARIOUS IONIZED LAYERS  
FOR QUIET SUN SPOT ACTIVITY

ELECTRONS PER CM<sup>3</sup>

KEY:  
 JUNE  
 DECEMBER  
 DATA NOT GIVEN  
 BUT ASSUMED COURSE  
 PRESENTED  
 DATA EXTRACTED  
 FROM NATIONAL BUREAU  
 OF STANDARDS

THOMAS S. NAREKIAN  
 NOV. 1968

CHART #1

TIME OF DAY

6 AM 12 6 P.M. 12 6 AM

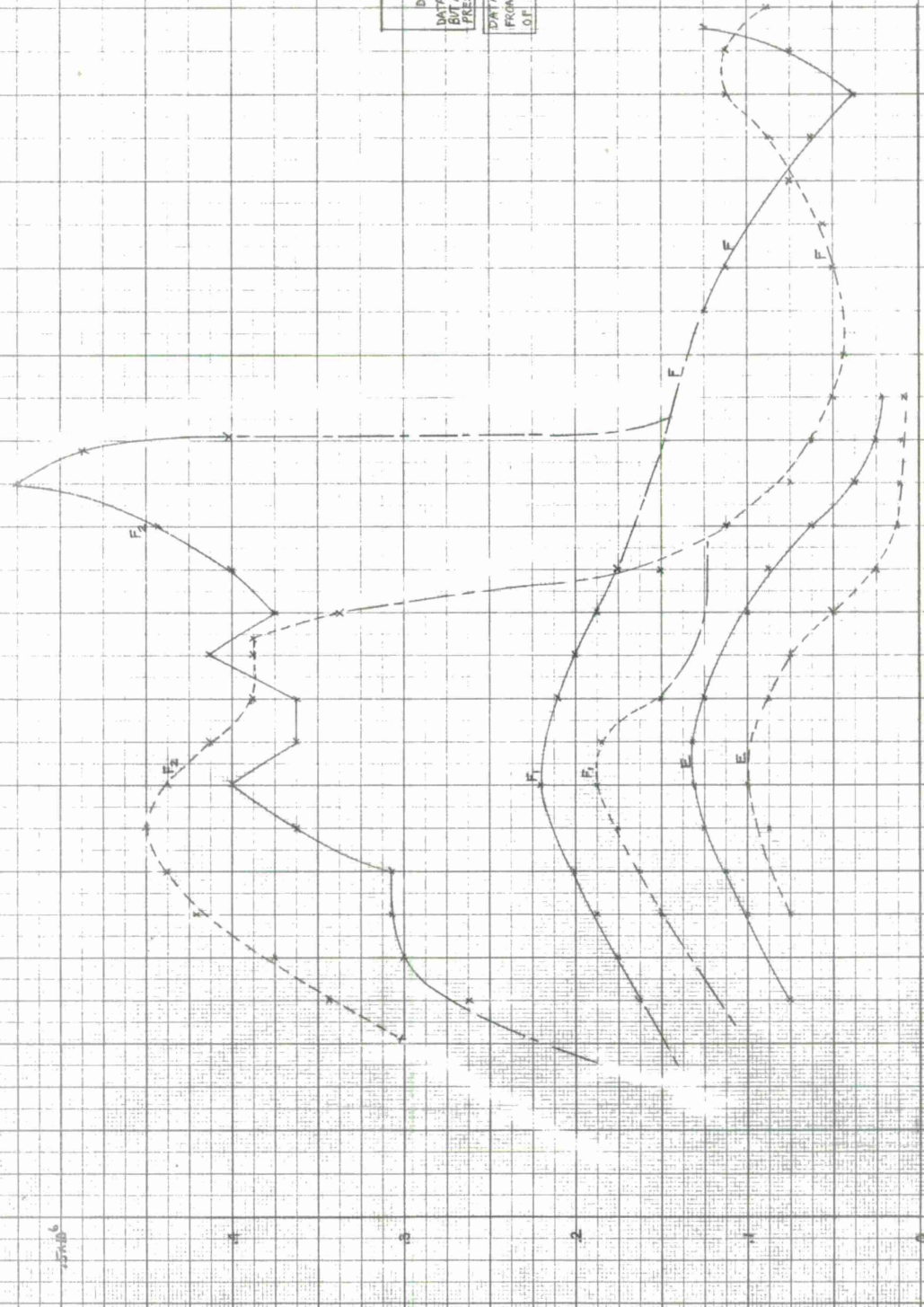

EXPERIMENTAL DATA FOR SEASONAL  
AND DIURNAL AVERAGES OF VIRTUAL  
HEIGHTS FOR VARIOUS IONOSPHERIC  
LAYERS. (SUNSPOT ACTIVITY EXCLUDED)

KEY:  
— TIME  
- - - DECEMBER

DATA EXTRACTED FROM  
NATIONAL BUREAU OF STANDARDS

THOMAS S. NABERNAN  
NOV. 1963

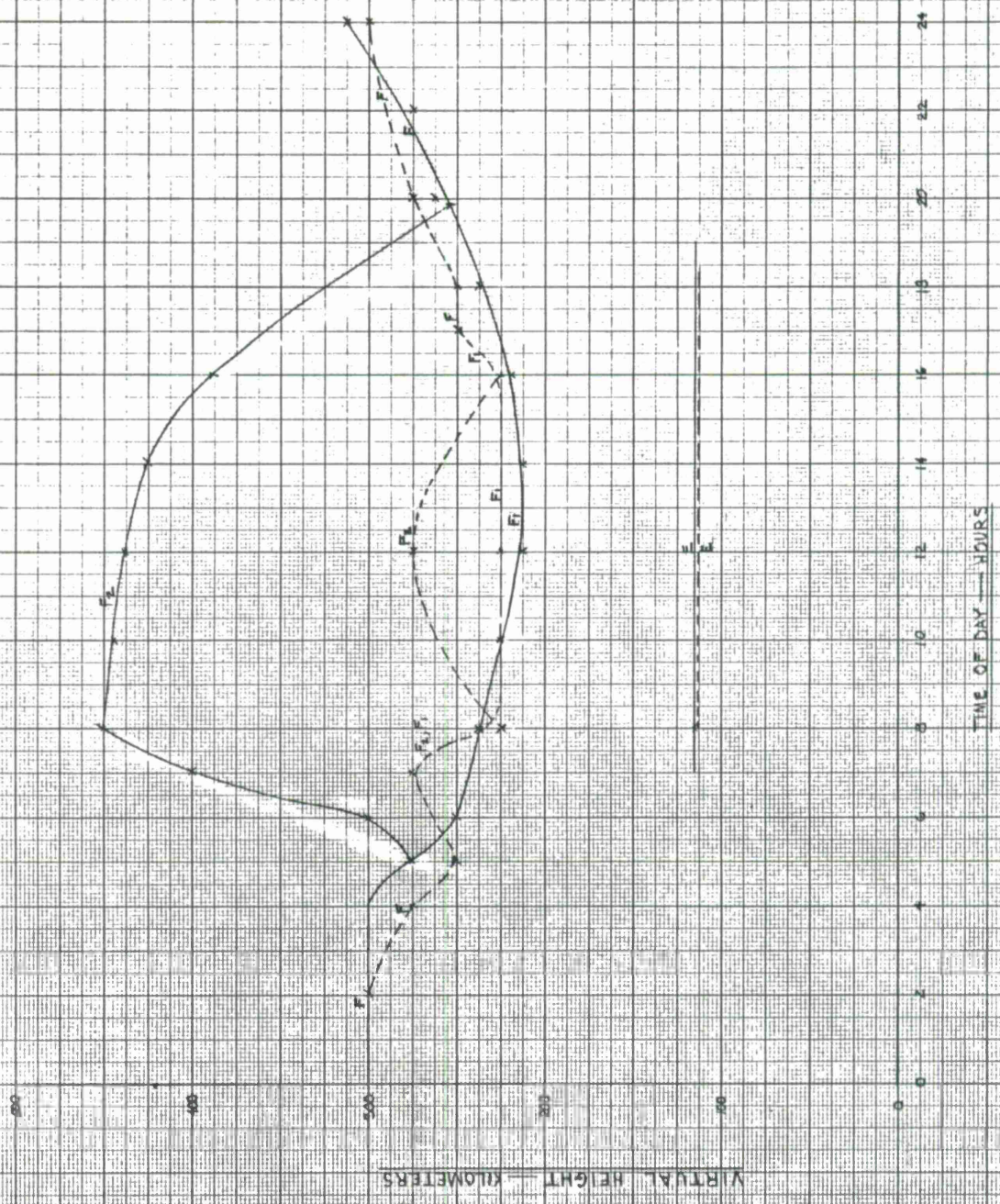
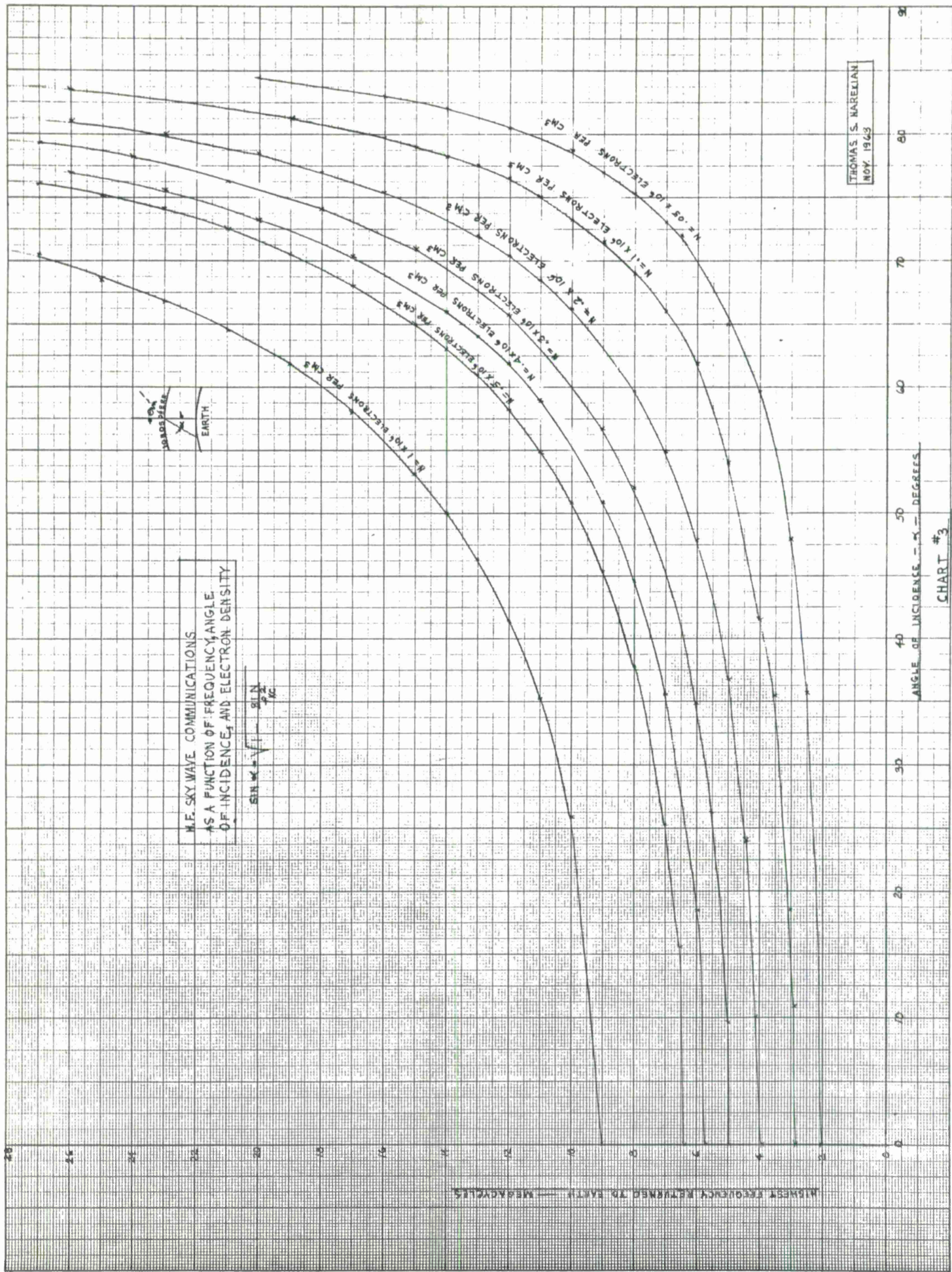

CHART #2



SINGLE HOP SPAN OF COMMUNICATIONS  
 WITH AT LEAST HALF POWER TRANSMITTED,  
 LOW SUN SPOT ACTIVITY, AND M.F. LOG  
 PERIODIC ANTENNA UTILIZED

NOTE:  
 DATA PRESENTED  
 FOR TWO EXTREME SEASONS  
 JUNE  
 DECEMBER

1 KM = 978 MILE

CRITICAL  
 TIME OF  
 DAY

CRITICAL  
 TIME OF  
 DAY

RANGE — KILOMETERS

FREQUENCY — MEGACYCLES

CHART #4

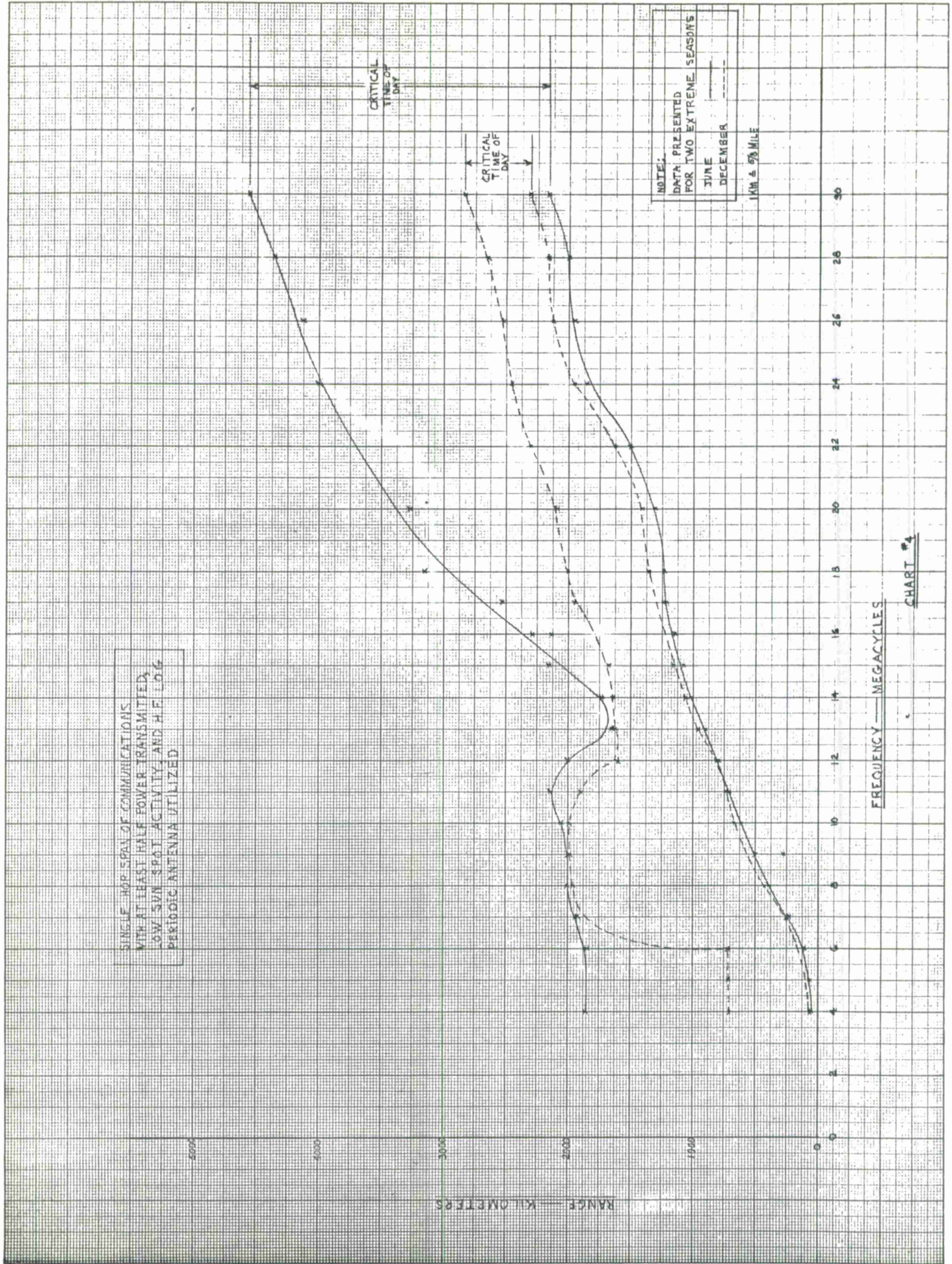

This span of communications as a function of frequency, is represented graphically in Chart 4 and two seasonal extremes, June and December, are presented to first depict the randomness of the ionosphere, and second the limits of transmission due to this randomness. Data for the construction of Chart 4 is presented in Tables 2 and 3.

Utilizing Chart 4, the propagation prediction now merely becomes a selection of operating frequency that will provide the desired range of communications.

In justifying the elevation pattern characteristics of the proposed antennas and referring to Chart 4, the 400 and 2000 mile requirements, corresponding to 640 and 3200 kilometers, are provided for by the antennas, marginally during the winter months and more conclusively during the summer months. The communications that would be established during winter months, are marginal only in that the graphs represent low sunspot activity, and any increase at all in this activity would definitely bring communications probability out of the marginal area (this low sun spot activity occurs very infrequently or on the average of one out of 11 years). Then too, it cannot be said that the 2000 mile capability will be degraded for even that one year out of eleven, for the graphs have been constructed on the assumption that at least half power is to be transmitted and, of course, communications can be established on a lot less effective power, as was evidenced recently by simple whip antenna transmission between Mitchell and Ramey (the log-periodic antenna transmission system can sacrifice 8 db of directive gain and still be as effective as the whip system).

In conclusion, it is readily apparent that the two proposed antennas will increase the effective transportability of the system without compromising the capability of the system.

Note: The following statements were added after original draft submission of this report.

In investigating the many designs and configurations of antennas for Tactical EMS use it was found that any antenna designed to meet all the military require-

ments had serious operational limitations. They are as follows.

1. Excessive space required for erection.
2. Too heavy for handling and transportation.
3. Too long an erection time.
4. Too bulky for storage.

It will be noted that none of these drawbacks are of an electrical nature. The first thought is that the only problem is one of a mechanical redesign. Unfortunately this is not true.

The electrical characteristics and frequency range specified set the basic ground rules for its physical size and to some extent its general configuration. This in turn reflects its weight and bulk along with the space necessary to erect the antenna. With a large and bulky antenna it will take more men to handle it.

Consideration shall be made as to methods to reduce or improve on some or all of these problem areas with respect to trade-offs of electrical specifications.

The present HF antenna requirements call for a 2 to 30 mc. frequency coverage. At 2 mc. a wavelength is approximately 492' while at 6 mc. it is approximately 164'. This is a 66% reduction in length for a 14% reduction in frequency. The high frequency end of the band is not considered because physical size is dependent only on the lowest frequency specified.

Another aspect of frequency is the "use factor" in long range point-to-point communications. Propagation factors and MUF (Maximum Useable Frequency) for annual and daily variations indicate a frequency range of about 6 to 17 mc. provides well over a 90% use factor. This means that if an antenna has a frequency range of only 6 to 17 mc., it would be capable of providing all the RF characteristics for reliable communications for greater than 90% of the time in the HF band under all propagation variations. The antenna size is reduced by at least 50% with a corresponding reduction in weight.

Some manufacturers have antennas built to a limited frequency range in the HF band. The major drawback of these antennas are the wind and ice loading characteristics. They are capable of withstanding only about 1/2 the wind and little or no iceloading required by most military specifications. It is possible that a stronger material and better guying of the structures could increase this capability. It may be that some form of heating of the antenna elements and support structure could eliminate the icing problem.

Another approach is to consider the advantages of having a very light and easily handled antenna that two men could raise or lower in a very short time. This would permit the antenna to be lowered if storms and high winds were approaching. The omnidirectional whip antenna is always erected and available for use whenever the directional antenna is lowered so there is never a complete loss of communication capability. The omnidirectional whip antenna is also capable of operating over the low end of the HF band which again insures some means of communication over the entire HF band of 2 to 30 mc.

The disadvantage of the omnidirectional antenna is of course its lack of gain and vulnerability to enemy intercept and ECM action. Actually this is somewhat true of any antenna in the HF band because of its inherent broad beamwidth and relatively poor front-to-back ratios.

With the previous discussion in mind it is possible to arrive at some practical considerations for a transportable directional HF antenna.

- |                     |                         |
|---------------------|-------------------------|
| 1. Frequency        | 6 to 30 mc.             |
| 2. Polarization     | Horizontal              |
| 3. Gain             | 8 db over isotropic     |
| 4. VSWR             | 2.0 : 1                 |
| 5. Impedance        | 50 ohms                 |
| 6. Az. Beamwidth    | 60°                     |
| 7. Vert. Beamwidth  | Change with frequency   |
| 8. Power Capability | As required with system |

- |                    |                                     |
|--------------------|-------------------------------------|
| 9. Volume (Stowed) | 200 cubic ft.                       |
| 10. Weight         | 2000 lbs.                           |
| 11. Area (Erected) | Within a 200' dia. circle           |
| 12. Erection time  | 2 men, 4 hours                      |
| 13. Wind loading   | 100 mph, operational                |
| 14. Ice loading    | 1/2" ice in 50 mph winds (survival) |

Along with a specification requirement there should be some statements as to the expected data to be supplied even though not specified.

A set of measured gain and beamwidth figures along with VSWR should be provided from the finished antenna.

Measurements or calculations of front-to-back ratio and side lobe pattern are helpful in determining the antennas effectiveness and use in certain system configurations.

Calculations of the wind and ice loading characteristics of the antenna support structure and elements should be available. These figures should include maximum operational capabilities and maximum survival.

If it is not practical to construct a tactical antenna to withstand high winds and ice loading conditions, it may be practical to have a "quick breakdown" procedure. If one or two men could set the antenna in a storm secure condition in 30 minutes or less, it would be advisable to accept this in place of rigid wind and ice loading requirements. The same condition for "quick breakdown" should hold for the erection time after the storm has passed.

A possible method of reducing ice loading on antenna elements and support structure could be the coating or covering of all solid surfaces with Teflon or other suitable material. Teflon resists adherence of moisture and foreign particles and is capable of withstanding extremes of temperature.

Another desirable feature of directional antennas is the capability of rotating it either electrically or mechanically.

For simplicity it may be feasible to provide a boom at or near the base of the support structure which could be rotated by one man in an arc to change the direction of the antenna. This aids in setting up the antenna since the signal is peaked for optimum performance with the station your operating with. The ability to change direction also permits rotating the antenna to eliminate or reduce interfering signal in a null of the antenna pattern. In many instances this can be done without seriously degrading the desired signal.

In conclusion lets compare the characteristics of a recently developed transportable HF antenna with desirable characteristics for Tactical EMS use.

Manufacturer: Collins Radio: Model 637B - 1A

	<u>Desired</u>	<u>637B - 1A</u>
Frequency	6 to 30 mc.	6.5 to 30 mc.
Polarization	Horizontal	Horizontal
Gain	8 db	12 db
VSWR	2.0 : 1	2.0:1 (Nom) 2.5:1 (Max.)
Impedance	50 ohms	50 ohms
Az. beamwidth	60°	65°
Vert. beamwidth	Vary with freq.	Vary with freq.
Power capabilities	As required	10 Kw. PEP or Avg.
Volume (Stowed)	200 cu. ft.	100 cu. ft.
Weight	2000 lbs.	1200 lbs.
Area (Erected)	Within 200' dia.	90' × 135'
Erection time	2 men, 4 hours	2 men, 3 hours
Wind loading	100 mph	60 mph
Ice loading	1/2" ice/50 mph	None

Note: The 637B - 1A also has remote control electric drive rotation over 180° and the drive motor is used as a power assist in erection of the antenna and driving anchors for guying.

D. MINIATURIZATION THROUGH DEVELOPMENT OF STATE-OF-THE-ART TECHNIQUES

For the third approach to the miniaturization problem, an extensive search and then a series of evaluations were performed in quest of promising, state-of-the-art antenna designs.

During the research phase, it became apparent that other armed services and government agencies were doing similar investigations in the area of tactical, HF, broadband antenna design. All applicable reports will be submitted for reference in Section IV of this report. Most of the antenna designs described in these reports were still in the development phase and only a small number of them will warrant further development time. Of course this third approach was more of a long term approach in that the experimental designs were to be investigated for concept at first, and then it was to be decided if increased development time and direction of effort would produce to choice design.

All those designs and concepts that have been investigated, again, are submitted for comprehensiveness. Remarks are stated for each concept or design to assist in the determination of its suitability.

1. Antenna Designs Investigated

(a) Fast Wave – Poor due to radial variations in the directivity of antenna pattern.

(b) Multi-Turn Loops – Poor efficiency and its inherent narrow band characteristics would require complex tuning and switching arrangements.

(c) Hula Hoop – Poor due to complex tuning and switching.

(d) Scimitar – Nonuniform radiation patterns (presently not a true frequency independent device); directionality poor.

(e) Log-Periodic Sinuous – "Extended" antenna directionality observed at high end of band only; nonuniform radiation pattern observed on "folded" antenna; erection problem would not be improved.

- (f) Log-Conical Spiral – Technically feasible and mechanically advantageous; warrants further investigation.
- (g) Backfire Helical – Poor bandwidth coverage.
- (h) Single or Double Wire Slot – Bi-directional; gain measurements not confirmed.
- (i) Bow Tie Slot – VSWR and bandwidth requirements cannot be met.
- (j) Fan Fed Wire Slot – Feasible if corner reflector utilized.
- (k) Log-Periodic Loops – Bi-directional; inefficient; narrow band and requires tuning.
- (l) Concentric Ring Circular Array – Severe mutual coupling causes wide variations in input impedance.
- (m) Double Arm Conical Spiral – Radiated lobe rotates about the cone axis with a change in frequency.
- (n) Archimedes Spiral – Looks promising for radiation pattern and input impedance remain relatively constant over required bandwidth; pattern is to be made directional, however.
- (o) Log-Periodic Planar Toothed – Nonuniform radiation pattern experienced and bi-directional.
- (p) Log-Periodic Vee – High directivity but economy in size sacrificed due to odd multiple wavelength operation.
- (q) Log-Periodic Trapezoid – Feasible design but erection problems are evident.
- (r) Spiral – Poor gain; interference high due to lack of directivity; and, pattern rotation observed over frequency bandwidth.

## 2. Applicable Antenna Designs

- (a) Fan-Fed Wire Slot with Corner Reflector – Wide band; moderate height; easy construction; small surface area required; simple feed; narrow beam-width or good directionality. For more bandwidth, a configuration utilizing a number of these antennas may be employed.

(b) Log-Conical Spiral – Size reduction in order of 35% if element loaded and new feeding method applied. Wind resistance might hamper performance and circular polarization must be utilized.

(c) Archimedes Spiral with Corner Reflector – Reflector required due to bi-directional radiation pattern. Antenna has radiation and impedance uniformity.

(d) Scimitar and Log-Periodic Sinuous – These antennas may prove feasible if more development time can be spared. Design parameters must be reworked for better broadband representation.

TABLE 3. DETERMINING RANGE OF COMMUNICATIONS FOR GIVEN FREQUENCY OF TRANSMISSION

(Month of June)

Freq.	L.H.P.	U.H.P	Max. Take	L.H.P.	U.H.P.
	Take Off Angle	Take Off Angle	Off Angle That Will Be Returned	$\alpha$	$\alpha$
4 Mc	18.0°	82°	82°	72°	8°
5	17.73	80.3	80.3	72.27	9.7
6	17.46	78.06	78	72.54	11.9
7	17.2	77	65	72.8	13
8	16.92	75.2	52	73.08	14.8
9	16.65	73.5	45	73.35	16.5
10	16.4	72	39	73.6	18
11	16.1	70	35	73.9	20
12	15.85	68	31.75	74.15	22
13	15.6	67	29	74.4	23
14	15.3	65	27	74.7	25
15	15.05	63	25	74.95	27
16	14.75	62	23.5	75.25	28
17	14.5	60	22	75.5	30
18	14.2	58	21	75.8	32
20	13.7	55	18.5	76.3	35
24	12.6	48	15.5	77.4	42
26	12.1	44.8	14.25	77.9	45.2
28	11.5	41.3	14	78.5	48.7
30	11	38	13	79	52

- NOTES: 1. For at least half power transmitted.  
 2. Analysis made with quiet sun spot activity (SSA)  
 3.  $\alpha$  = Optical Angle of Incidence

TABLE 4. DETERMINING RANGE OF COMMUNICATIONS FOR GIVEN FREQUENCY OF TRANSMISSION

(Month of June)

Freq.	E for L.H.P. $\times 10^6$	E for Max. Angle $\alpha$ that will still return frequency	Layer Utilized		Time LHP
			LHP	MUP	
4 Mc	.045	.19	F	F <sub>1</sub>	4:00 a.m.
			E	F <sub>1</sub>	6:45 p.m.
5	0.47	.3	F		4:00 a.m.
			E	F <sub>2</sub>	6:45 p.m.
6	.0485	.425	F	F <sub>2</sub>	4:00 a.m.
			E	F <sub>2</sub>	6:45 p.m.
7	.05	13 R @ .60 .5 @ 25	E	F <sub>2</sub>	6:30 p.m.
			F		3:30 a.m. F 4:30 a.m.
8	.054	14.8 R @ .75 .5 @ 38	E		E 6:15 p.m.
			F	F <sub>2</sub>	3:15 a.m. F 4:30 a.m.
9	.07	16.5 R @ .95 .5 @ 45	E		5:45 p.m.
			F	F <sub>2</sub>	3:00 a.m. F 4:45 a.m.
10	.09	18 N.R. .5 @ 51	E		E 8:00 a.m., 4:45 p.m.
			F	F <sub>2</sub>	F 1:30 & 5:15 a.m.
11	.115	20 N.R. .5 @ 55	E		E 10:00 a.m., 3:00 p.m.
			F	F <sub>2</sub>	F 12:00 p.m., 5:30 p.m.
12	.135	22 N.R. .5 @ 58.25	F	F <sub>2</sub>	10:15 p.m.
13	.16	23 N.R. .5 @ 61	F <sub>1</sub>	F <sub>2</sub>	5:15 p.m.
14	.175	25 N.R. .5 @ 63	F <sub>1</sub>		8:00 a.m.
			F <sub>1</sub>	F <sub>2</sub>	5:00 p.m.
15	.19	27 N.R. .5 @ 65	F <sub>1</sub>		F 9:00 a.m., 4:00 p.m.
			F <sub>2</sub>	F <sub>2</sub>	F 5:30 a.m., 8:00 p.m.

TABLE 4 . DETERMINING RANGE OF COMMUNICATIONS FOR GIVEN FREQUENCY OF TRANSMISSION (Cont.)

(Month of June)

Freq.	E for L.H.P. $\times 10^6$	E for Max. Angle $\alpha$ that will still return frequency	Layer Utilized		Time LHP
			LHP	MUP	
16	.21	28 N.R. .5 @ 66.5	F <sub>1</sub>		10:45 p.m., 2 p.m.
			F <sub>2</sub>	F <sub>2</sub>	6:00 a.m., 8 p.m.
17	.23	30 N.R. .5 @ 68	F <sub>2</sub>	F <sub>2</sub>	6:15 a.m. 8:00 p.m.
18	.24	32 N.R. .5 @ 69	F <sub>2</sub>	F <sub>2</sub>	7:00 a.m. 8:00 p.m.
20	.275	35 N.R. .5 @ 71.5	F <sub>2</sub>	F <sub>2</sub>	7:00 a.m. 8:00 p.m.
24	.34	42 N.R. .5 @ 74.5	F <sub>2</sub>	F <sub>2</sub>	10:30 a.m.
26	.35	45.2 N.R. .5 @ 75.75	F <sub>2</sub>	F <sub>2</sub>	10:45 a.m.
28	.35	48.7 N.R. .5 @ 76	F <sub>2</sub>	F <sub>2</sub>	10:45 a.m.
30	.34	52 N.R. .5 @ 77	F <sub>2</sub>	F <sub>2</sub>	10:30 a.m.

- NOTES:
1. For at least half power transmitted.
  2. N.R. = Not Returned (Electron density not to be found).
  3.  $\alpha$  = Optical Angle of Incidence
  4. E = Electron Density
  5. Analysis made with quiet sun spot activity (SSA)

TABLE 5. DETERMINING RANGE OF COMMUNICATIONS FOR GIVEN FREQUENCY OF TRANSMISSION

(Month of June)

Freq.	Time	Virtual Height		Single Hop Span Range		
		MUP	LHP	MUP	LHP	MUP
4 Mc	9 a.m.		300	230	1848	65
	4 p.m.		115 Km	220 Km	710 Km	62 Km
5	8 a.m.		300	450	1848	154
			115		710	
6	5:30 p.m.		300	325	1848	136
	8:45 p.m.		115	250	710	104
7	7 p.m.		115		740	
			300	250	1936	230
8	7 p.m.		115		760	
			300	250	2000	390
9	7 p.m.		115		770	
			300	250	2000	500
10	7 p.m.		287	250	1920	
			115, 115		780, 780	
11	7 p.m.		300, 270	250	2040, 1840	620
			115, 115		800, 800	
12	7 p.m.		310, 230	250	2140, 1600	710
			285	250	2000	810
13	7 p.m.		230	250	1650	900
			237		1730	
14	7 p.m.		225	250	1640	1020
			230		1710	
15	7 p.m.		220		1630	
			287, 250	250	2140, 1860	1080
16	7 p.m.		220		1670	
			215	250	1625	
			300, 250	250	2280, 1900	1150

TABLE 5. DETERMINING RANGE OF COMMUNICATIONS FOR GIVEN FREQUENCY OF TRANSMISSION (Cont.)

(Month of June)

Freq.	Time	Virtual Height		Single Hop Span Range	
		LHP	MUP	LHP	MUP
17	7 p.m.	325		2520	
		250	250	1940	1240
18	7 p.m.	400		3160	
		250	250	1980	1300
20	7 p.m.	400		3280	
		250	250	2040	1500
24	7 p.m.	445	250	4000	1860
26	7 p.m.	443	250	4130	1970
28	7 p.m.	443	250	4360	2000
30	7 p.m.	445	250	4560	2165

- NOTES: 1. For at least half power transmitted.  
 2. Analysis made with quiet sun spot activity (SSA)

TABLE 6. DETERMINING RANGE OF COMMUNICATIONS FOR GIVEN FREQUENCY OF TRANSMISSION

(Month of December)

Freq.	L.H.P. Take Off Angle	U.H.P. Take Off Angle	Maximum Angle Utilized	$\alpha$ L.H.P.	$\alpha$ U.H.P.
4 Mc	18.0°	82°	82°	72°	8°
5	17.73	80.3	80.3	72.27	9.7
6	17.46	78.1	78.1	72.54	11.9
7	17.2	77	65	72.8	13
8	16.92	75.2	52	73.08	14.8
9	16.65	73.5	45	73.35	16.5
10	16.4	72	39	73.6	18
11	16.1	70	35	73.9	20
12	15.85	68	31.75	74.15	22
13	15.6	67	29	74.4	23
14	15.3	65	27	74.7	25
15	15.05	63	25	74.95	27
16	14.75	62	25	75.25	28
17	14.5	60	23.5	75.5	30
18	14.2	58	22	75.8	32
20	13.7	55	21	76.3	35
22	13.2	51.5	18.5	76.8	38.5
24	12.6	48	15.5	77.4	42
26	12.1	44.8	14.25	77.9	45.2
28	11.5	41.3	14	78.5	48.7
30	11	38	13	79	52

- NOTES: 1. For at least half power transmitted.  
 2. Analysis made with quite sun spot activity (SSA).  
 3.  $\alpha$  = Optical Angle of Incidence.

TABLE 7. DETERMINING RANGE OF COMMUNICATIONS FOR GIVEN FREQUENCY OF TRANSMISSION

(Month of December)

Freq.	E for L.H.P. $\times 10^6$	E for Maximum a That Will Still Return Frequency	Layer Utilized		Time LHP
			LHP	MUP	
4 Mc	.045	.19	E	F <sub>1</sub> F <sub>2</sub>	4:15 p.m.
5	.047	.3	E	F <sub>2</sub>	4:15 p.m.
6	.0485	.425	E	F <sub>2</sub>	4:30 p.m.
7	.05	13 R @ .60	E		6:30 a.m., 4:00 p.m.
		.45 @ 30	F	F <sub>2</sub>	9:00 p.m., 12:00 mid.
8	.054	14.8 R @ .75	E		7:00 a.m., 3:45 p.m.
		.45 @ 41.25	F	F <sub>2</sub>	8:45 p.m., 12:30 a.m.
9	.07	16.5 R @ .95	E		8:30 a.m., 3:15 p.m.
		.45 @ 48.25	F	F <sub>2</sub>	7:30 p.m., 2:00 a.m.
10	.09	18 N.R.	E		10:30 a.m., 2:00 p.m.
		.45 @ 53	F	F <sub>2</sub>	6:45 p.m., 3:00 a.m.
11	.115	20 N.R.	E		6:00 p.m.
		.45 @ 57	F <sub>1</sub>	F <sub>2</sub>	7:00 a.m., 3:15 p.m.
12	.135	22 N.R.	E		5:30 p.m.
		.45 @ 60	F <sub>1</sub>	F <sub>2</sub>	8:00 a.m., 2:30 p.m.
13	.16	23 N.R.			9:45 a.m.
		.45 @ 62.5	F <sub>1</sub>	F <sub>2</sub>	1:45 p.m.
14	.175	25 N.R.			11:00 a.m.
		.45 @ 64.6	F <sub>1</sub>	F <sub>2</sub>	1:30 p.m.
15	.19	27 N.R.			
		.45 @ 66.25	F <sub>1</sub>	F <sub>2</sub>	12:30 p.m.
16	.21	28 N.R.			3:45 a.m.
		.45 @ 68	F <sub>2</sub>	F <sub>2</sub>	5:30 p.m.
17	.23	30 N.R.			5:15 a.m.
		.45 @ 69.3	F <sub>2</sub>	F <sub>2</sub>	5:00 p.m.

TABLE 7. DETERMINING RANGE OF COMMUNICATIONS FOR GIVEN FREQUENCY OF TRANSMISSION (Cont.)

(Month of December)

Freq.	E for L.H.P. $\times 10^6$	E for Maximum $\alpha$ That Will Still Return Frequency	Layer Utilized		Time LHP
			LHP	MUP	
18	.24	32 N.R.			5:30 a.m.
		.45 @ 70.3	F <sub>2</sub>	F <sub>2</sub>	4:45 p.m.
20	.275	35 N.R.			5:30 a.m.
		.45 @ 72.5	F <sub>2</sub>	F <sub>2</sub>	4:45 p.m.
22	.315	38.5 N.R.			6:30 a.m.
		.45 @ 74.0	F <sub>2</sub>	F <sub>2</sub>	6:30 a.m.
24	.34	42 N.R.			7:00 a.m.
		.45 @ 75.3	F <sub>2</sub>	F <sub>2</sub>	4:00 p.m.
26	.35	45.2 N.R.			7:15 a.m.
		.45 @ 76.25	F <sub>2</sub>	F <sub>2</sub>	3:50 p.m.
28	.35	48.7 N.R.			7:15 a.m.
		.45 @ 76.8	F <sub>2</sub>	F <sub>2</sub>	3:50 p.m.
30	.34	52 $\times 10^6$ N.R.			7:00 a.m.
		.45 @ 77	F <sub>2</sub>	F <sub>2</sub>	4:00 p.m.

- NOTES:
1. For at least half power transmitted.
  2. N.R. = Not returned (Electron density not to be found).
  3. Analysis made with quiet sun spot activity (SSA).
  4. E = Electron Density.
  5.  $\alpha$  = Optical Angle of Incidence.

TABLE 8. DETERMINING RANGE OF COMMUNICATIONS FOR GIVEN FREQUENCY OF TRANSMISSION

(Month of December)

Freq.	Time	Virtual Height		Single Hop Span Range	
		LHP	MUP	LHP	MUP
4 Mc	12 noon				
	6:00 a.m., 4:30 p.m.	110	225 265, 235	680	62 74, 65
5	6:00 a.m. 4:00 p.m.	110	265, 225	690	90, 76
6	9:15 a.m. 12:30 p.m.	110	250 275	700	106, 116
7	11:00 a.m.	110, 110 285, 300	270	710, 710 1840, 1930	250
8	11:00 a.m.	110, 110 280, 300	270	725, 725 1840, 1980	425
9	11:00 a.m.	110, 110 250, 300	270	740, 740 1670, 2000	270
10	11:00 a.m.	110, 110 260, 290	270	750, 750 1770, 2000	670
11	11:00 a.m.	250 275, 225	270	1670 1900, 1560	770
12	11:00 a.m.	110 225, 225	270	780 1600, 1600	870
13	11:00 a.m.	225, 225	270	1620	980
14	11:00 a.m.	225, 225	270	1640	1060
15	11:00 a.m.	225	270	1670	1160
16	11:00 a.m.	280, 250	270	2130, 1900	1160
17	11:00 a.m.	252, 250	270	1950, 1940	1240
18	11:00 a.m.	255, 245	270	2000, 1940	1340
20	11:00 a.m.	255, 245	270	2090, 2000	1410
22	11:00 a.m.	270	270	2300	1620
24	11:00 a.m.	275, 225	270	2460, 2000	1950

TABLE 8. DETERMINING RANGE OF COMMUNICATIONS FOR GIVEN FREQUENCY OF TRANSMISSION (Cont.)

(Month of December)

Freq.	Time	Virtual Height		Single Hop Span Range	
	MUP	LHP	MUP	LHP	MUP
26	11:00 a.m.	270, 230	270	2520, 2150	2120
28	11:00 a.m.	270, 230	270	2650, 2260	2170
30	11:00 a.m.	275, 225	270	2830, 2310	2340

- NOTES: 1. For at least half power transmitted.  
 2. Analysis made with quiet sun spot activity (SSA).

## E. CONCLUSIONS

If the present antenna system continues to be utilized, then the arrow head ground anchor should undergo tests to determine the decrease in antenna erection time it will afford.

Although greater length is a characteristic of RF loading of log-periodic antennas, a shortening of mast height will also result. Herein, the erection time will be decreased. Inductive loading is the most feasible loading technique and its effect may be enhanced by a suitable ferrite core.

Either of two antennas, the All Products Company LPH-3C or the Granger 747CA, can increase the capability of the present antenna system.

A number of new HF, broadband antenna concepts warrant more development time and direction of effort. These are as follows: the log-conical spiral, the scimitar, the log-periodic sinuous, the Archimedes spiral (with unidirectional arrangement), and the fan-fed wire slot (with unidirectional arrangement).

## F. RECOMMENDATIONS

For a quick reaction approach to the problems of bulk, weight, and erection time, the All Products horizontally polarized LPH-3C or the Granger horizontally polarized 747-CA is recommended. Both antennas will afford the same capability and availability, however, Granger's 747CA costs \$4,300 more than All Products' LPH-3C.

For an intermediate solution to the problem, it is recommended that the present log periodic antenna be redesigned to utilize inductive loading.

For a long term approach, it is recommended that state-of-the-art antenna designs, such as, the Log-Conical Spiral, Scimitar, Log-Periodic Sinuous, Archimedes Spiral, and Fan-Fed Wire Slot, be further investigated with more specific goals and direction of effort.

It is also recommended that whatever approach or antenna is utilized, the arrow head ground anchor should be used in place of the present screw anchor.

### III. COMSEC PROBLEMS WITHIN THE EMS ENVIRONMENT

#### A. POINT-TO-POINT COMMUNICATIONS SYSTEMS

Any point-to-point communications system can be divided into a number of sub-groups. In general, the division is made by regarding transmission equipment, multiplex equipment and baseband equipment separately with respect to the unique security problems inherent in each grouping.

##### 1. Transmission Equipment

The transmission equipment involved in the system design of Section I of this report falls into three types: UHF/SHF Troposcatter equipment, HF/ISB equipment, and RACEP.

The troposcatter system operates in a bandwidth of 2 Mc with a power output of 1 kw as a wideband FM system. The lowest frequency used in the troposcatter analysis is 300 Mc. When this frequency is transmitted using a 10 foot parabolic antenna, the half power beamwidth in the  $\Sigma$  plane is approximately  $25^\circ$ . This antenna provides 17.5 db of gain, thus making the effective power output of the transmitter approximately 50 kw.

At a distance of 5000 feet from the antenna, the beam covers about 2000 feet across the half power points.

A beam of such width is rather easy to locate and monitor from the ground or from the air, and the source is easily found by direction finder equipment.

Because of this, troposcatter equipment should be operated at a higher frequency in order to reduce the susceptibility of the system to ECM. A frequency of 2GC provides a beamwidth of  $3.6^\circ$ . This angle intercepts about 300 feet at a range of 5000 feet and is far less susceptible to detection and ECM.

HF/ISB systems are extremely susceptible to detection and ECM, because of the wide antenna beamwidths and the possibility of extremely long distance transmission. Since little can be done about these characteristics, the only remaining course of action is disciplined use of transmission time and routine frequency changes at random intervals.

The RACEP signal is basically a pulsed carrier system utilizing three carrier frequencies randomly pulsed. It can be located easily because of the omnidirectional antenna pattern and is susceptible to noise and barrage type jamming. Intermittent usage is its only protection since its carrier frequencies are fixed and once an enemy ascertains that RACEP is being used, he can jam the RACEP band at leisure from great distances if he uses airborne ECM equipment. The monitoring of RACEP traffic will be discussed later in this report.

## 2. Multiplexing Equipment

Voice multiplex equipment for this system falls into two categories. The voice multiplexer for the HF portion is integral to the HF/ISB subsystem and voice channels are frequency multiplexed as independent sidebands about a related suppressed carrier. Thus, the HF voice channels appear as a group of single sideband signals in a 12kc portion of the HF spectrum and have the same characteristics and vulnerability of a single sideband signal. Unless voice encryption equipment is used, these transmissions can be monitored with any single sideband receiver, or with any communications receiver with good selectivity and a stable BFO.

The troposcatter voice multiplexing is accomplished by time division. This method utilizes sampling and allocates a particular time slot with respect to a transmitted reference.

For this reason, similar equipment must be used to monitor effectively the multiplexed channels. Since it is transmitted as a binary FM signal, it presents some resistance to ECM.

RACEP is also time multiplexed, but in a random access system. It, therefore, is even more difficult to monitor, since exact coincidence of the information carried on the three carriers is necessary. Monitoring of traffic, therefore, can only be done if the demultiplex equipment exactly reproduces the RACEP signal processing.

Teletype is frequency division multiplexed at voice frequencies and is transmitted on voice channels. The signals appear as steady tones on the channel, shifting frequency according to the 5 level teletype code being transmitted.

Standard 42.5 cps shift VFTG equipment is all that is necessary to demodulate this signal. However, because it is an FM system and because the bandwidth is rather narrow, it is far more resistant to ECM than wideband SSB voice.

#### B. A/G/A COMMUNICATIONS

The A/G/A Communications Equipment used in EMS applications is amplitude modulated at both VHF and UHF. Because of its application, omnidirectional antenna patterns must be used. Therefore, when the method of modulation and the method of transmission are considered, it can be seen that A/G/A Communications are highly vulnerable to monitoring and ECM.

Since these transmissions are sporadic in nature, they contain a great deal of intelligence in the traffic rate alone. Because of the type of traffic handled in these systems, however, encryption does not at this time appear to give an advantage.

#### C. COMSEC HARDWARE INTEGRATION

The Cosmec hardware currently in use on teletype circuits in the AN/TSC-23 is the KW-26. New cryptosystems for both voice and teletype are under development at this time. Therefore, any advanced communications system must take account of this situation in order to insure compatibility.

#### D. CONCLUSIONS

It is concluded that the entire Comsec aspect of communications in Emergency Mission Systems requires considerable further study. This discussion, therefore, is grossly incomplete and simply outlines some of the problems involved.

E. RECOMMENDATIONS

It is recommended that study of Comsec problems in EMS applications be continued.

It is further recommended that the proposed solutions to the unique Comsec problems of the various subsystems be implemented either as operating procedure or as subsystem characteristics where they are applicable.

#### IV. SUPPLEMENTARY MATTER

##### A. LIST OF REFERENCES

###### 1. Articles, Papers, and Reports for Tactical Communications

A Study of Redesign of AN/TSQ-47 Subsystems (Final Report) (Unclassified Title) (Secret); Technical Documentary Report Number ESD-TDR-63-133, Contract Number AF19(628)-1612; LFE Electronics, January, 1963.

Properties of Tropospheric Scattered Fields; N.R. Ortwein, R.U.F. Hopkins, J.E. Pohl; Proc. IRE, April 1961.

Tropospheric Scatter System Using Angle Diversity; J.H. Vogelman, J.L. Ryerson, M.H. Bickelhaupt; Proc. IRE, May 1959.

Antenna-Beam Configuration in Scatter Communications; Alan T. Waterman, Jr., Correspondence, Proc. IRE, Sept. 1961.

Properties of 400 MCPS Long Distance Tropospheric Circuits; J.H. Chisholm, W.E. Morrow, Jr., B.E. Nichols, J.F. Roche, A.E. Teachman, Proc. IRE, Dec. 1962.

Apparent Correlation Between Tropopause Height and Long Distance Transmission Loss at 490 Mc; D.R. Hay; Correspondence, Proc. IRE, June 1959.

Simple Methods for Computing Tropospheric and Ionospheric Refractive Effects on Radio Waves; S. Weisbrod, L.J. Anderson; Proc. IRE, Oct. 1959.

Selective Fading Effects on UHF Tropospheric Scatter Paths; H.J. VonBaeyer; Correspondence, Proc. IRE; Nov. 1959.

Research on Electrically Small Antennas; Prof. Dr. H.H. Meinke; Summary Report 2, Contract AF61(052)-506, Institut fur Hochfrequenztechnik der Technischen Hochschule Munchen, April 1963.

###### 2. Texts for Tactical Communications

Networks, Lines and Fields; J.D. Ryder; Prentice-Hall, Inc., 1956.

University Physics; F.W. Sears and M.W. Zemansky; Addison-Wesley Pub. Co.; 1953.

Antenna Engineering Handbook; Henry Jasik, Editor; McGraw-Hill Book Co., Inc., 1961.

Advanced Engineering Mathematics; C.R. Wylie, Jr.; McGraw-Hill Book Co., Inc., 1951.

Handbook of Mathematical Tables and Formulas; R.S. Burington, Handbook Publishers, Inc., 1954.

Theoretical Physics; Georg Joos; Hafner Pub. Co., 1950.

Principles of Noise; J.J. Freeman; John Wiley and Sons, Inc., 1958.

Information Transmission, Modulation and Noise; M. Schwartz, McGraw-Hill Book Co., Inc., 1959.

3: Antenna Manufacturers Contacted for Tactical High-Frequency  
Directional Antenna

Aerojet General Corporation  
Space General Corporation  
9200 East Flair Drive  
El Monte, California

Ainslie Corporation\*  
531 Pond Street  
South Braintree, Mass.

Airtronics, Inc.  
5221 River Road  
Washington 16, D.C.

All Products Company\*  
Box 520  
Mineral Wells, Texas

Alpan Manufacturing Corporation  
220 Demeter Street  
Palo Alto, California

American Electronic Laboratories, Inc.  
1311 Richardson Road  
Colmar, Pennsylvania

Amicon Corporation  
5903 City Avenue  
Philadelphia 31, Pennsylvania

Andrews Antennas\*  
P.O. Box 296  
Westwood, Mass.

Antenna Kogyo Company, Ltd.  
1202 Nakamaruko, Kawasaki-shi  
Kanagawa-ken, Japan

Antenna Research Associates\*  
Beltsville, Maryland

Antenna Specialties Company\*  
12435 Euclid Avenue  
Cleveland 6, Ohio

Antenna Systems, Inc.  
349 Lincoln Street  
Hingham, Mass.

Atlantic Research Corporation  
Shirley Highway at Edsall Road  
Alexandria, Virginia

Chu Associates  
P.O. Box 387  
Whitcomb Avenue  
Littleton, Mass.

Collins Radio Company\*  
19700 San Jaquin Road  
Newport Beach, California

Cush Craft  
621 Hayward Street  
Manchester, New Hampshire

Defense Electronics, Inc.  
5455 Randolph Road  
Rockville, Maryland

Dome and Margolin, Inc.  
9730 Cozycroft Avenue  
Chatsworth, California

Dynatronics, Inc.\*  
P.O. Box 2566  
Orlando, Florida

Electrada Corporation  
Electronics Division  
11244 Playa Street  
Culver City, California

General Dynamics Electronics\*  
P.O. Box 127  
San Diego 12, California

General Electronic Laboratories, Inc.\*  
18 Ames Street  
Cambridge 42, Mass.

Granger Associates\*  
1601 California Avenue  
Palo Alto, California

Hy-Gain Antenna Products\*  
6 at Stevens Creek  
Lincoln, Nebraska

I-T-E Circuit Breaker Company\*  
1900 Hamilton Street  
Philadelphia 30, Pennsylvania

Mark Products Company  
Division of Dynascan Corporation  
Department IRE-10  
5439 West Fargo Avenue  
Skokie, Illinois

Mosley Electronics, Inc.\*  
4610 North Lindbergh Boulevard  
Bridgeton, Missouri

Philco, Inc.  
WDL Division  
Palo Alto, California

Sinclair Radio Laboratories, Ltd.  
21 Toro Road  
Downsview, Ontario, Canada

Sumitomo Electric Industries, Ltd.  
60 Okijima Minamino-sho  
Konohana-ku  
Osaka, Japan

Sylvania Electric Products, Inc.  
Sylvania Electronic Systems Division  
730 Third Avenue  
New York 17, New York

\*Company Returned Requested Information.

4. ASTIA Reports Utilized for Tactical High-Frequency Directional Antenna

AD-293-866	Parasitic Excitation of Concentric Ring Circular Antenna Arrays
AD-293-867	Circular Loop and Circular Dipole Arrays
AD-293-991	High Frequency Spiral Antenna
AD-293-968	Broadband Antenna Study I
AD-406-463	Broadband Antenna Study II
AD-294-805	Tepee Billboard Array and Antenna Switching
AD-333-933	High Gain Steerable Antenna (Secret)
AD-292-943	Radiation Pattern of Dipole Array in Dielectric Slab
AD-292-984	Vertical Heavy Duty Mast
AD-291-765	Applications for the Design of Frequency Independent Antennas
AD-291-656	High Frequency Antenna Techniques
AD-331-866L	Radiation Patterns of High Frequency Antenna on B-70 Air Frame (Secret)
AD-285-678	Balanced Wire-Arm Conical Log-Spiral Antennas
AD-332-465	Prototype Antenna Systems
AD-267-214	High Frequency Antenna Techniques
AD-268-027	R.F.D. Antenna Techniques
AD-267-022	Frequency Independent Antennas for ECM Applications
AD-288-200	Studies on Problems on Log Periodics
AD-288-291	Tactical Antenna Systems
AD-288-026L	High Frequency Antenna - Fibre Glass
AD-288-270	Helical Monopole High Frequency Antenna
AD-278-588	Near Field Measurements of LP Antenna
AD-267-767	Broadband Antenna Study
AD-266-784	Design Criteria for LP Antennas

5. Other Applicable Reports for Tactical High-Frequency Directional Antenna

Berry, D.G. and Ore, R.F., "Log Periodic Monopole Array", 1961 IRE International Convention Record, Vol. 9, Part 1, Antennas and Propagation, pp 75-85.

Boueckmann and Hagaman, "Horn Antennas for HF Long-Range Communications", IRE AP-8, pp 523-526.

Carrel, R., "Design of Log Periodic Dipole Antennas", 1961 IRE International Convention Record, Vol. 9, Part 1, Antennas and Propagation, pp 61-75.

Carter, Hansell, and Lindenblad, "Development of Directive Transmitting Antenna by RCA Communications", Oct. 1951, Proc. IRE 19, pp 1173-1842.

DuHamel, R.H. and Isbell, D.E., "Design of Broadband Log Periodic Antenna Structures", 1957 IRE National Convention Record, Vol. 5, Part 1, pp 119-128.

DuHamel, R.H. and Ore, F.R., "Log Periodic Antenna Designs", 1958 IRE National Convention Record, Vol. 6, Part 1, pp 139-151.

Dyson, J.D., "A Survey of the Very Wideband and Frequency Independent Antennas 1945 to Present", Journal of Research of the NBS, Vol. 660, No. 1, pp 1-6, Jan-Feb 1962.

Dyson, J.D., "The Unidirectional Equiangular Spiral Antenna", University of Illinois, Antenna Lab, TR No. 33, July 10, 1958.

Frank and Elfving, C.T., "Reflector Type Periodic Broadband Antennas", 1958 IRE Wescon, Part 1, pp 262-271.

Greiser and Mayes, "Vertical Polarized Log Periodic Zig-Zag Antennas", Proc. Nat. Elect. Conference, Vol. 17, 1961, pp 193-204.

Hickman, Neff, and Till, "Theory of Single Ring Circular Antenna Array", Trans. AIEE, Vol. 80, May 1961, p 110.

Isbell, D.E., "Log Periodic Dipole Arrays", IRE Trans. Antenna and Propagation, Vol. AP-8, May 1960, pp 260-267.

Mayes and Carrel, R., "High Gain Log Periodic Antennas", Proc. 10th Symp. USAF Antenna R&D Program, University of Illinois, Oct. 1960.

Mayes and Carrel, R., "Log Periodic Resonant V Arrays", Tech. Report No. 47, Antenna Lab, University of Illinois, July 15, 1960.

Ramsey, "Frequency Independent Antenna", 1957 IRE Nat. Convention Record, Part 1, pp 144-148.

Shimizu, Jones, and Honey, "A Sinuous Flush-Mounted Frequency Independent Antenna", Scientific Report No. 3, Stanford Research Institute, Oct. 1959.

Weeks, W.L., "Estimation of Ferrite Loop Antenna Impedance", 10 April 1957 for Wright Air Development Center by E.E. Research Engineering, University of Illinois.

6. Texts Utilized for Tactical High Frequency Directional Antenna Antennas; John D. Kraus; McGraw-Hill, 1950.

Antenna Engineering Handbook; Henry Jasik; McGraw-Hill, 1961.

Antennas: Theory and Practice; Serger, A. Schelkunoff, and H.T. Frus; John Wiley and Sons, 1952.

Radio Engineering; F. Terman; McGraw Hill.

Radio Engineers' Handbook; F. Terman, McGraw-Hill.

Radio Wave Propagation; C.R. Burrows and S.S. Attwood; Academic Press, 1949.

Reference Data for Radio Engineers; International Telephone and Telegraph, 1956.

Theoretical Physics; G. Joos; Hafner Publishing, 1950.

Transmission Line Circuit Analysis; J.L. Stewart; John Wiley and Sons, 1958.

## B. APPENDIX

### 1. Project Tobacco Can

Project Tobacco Can is a plan for implementing radio relay communications by strategic placement of small unmanned air droppable frequency translating repeaters. These repeaters should be simple in electronic design, have low battery drain, be contained within a plastic compound, be inexpensive and, therefore, expendable. These devices can be strategically located either by parachute drop or infantry patrols. A one shot ring pin activated device is planned to provide on-off switching. It is recommended that these repeaters be booby-trapped to discourage tampering.

The following system study shows the technical feasibility of Project Tobacco Can.

### Radio Relay Terminal

Power Output	40 watts
Bandwidth	1 Megacycle
Receiver Noise Figure	10 db
Carrier Frequency	600 Megacycles
Antenna	Monopole

At a distance of 15 statute miles with a repeater power output of 1 watt, the input level at the terminal receiver will be 12 microvolts across 50 ohms (-85 dbm). This gives a signal to noise ratio of 19 db. The input levels at the repeater for the terminal transmitter at 15 statute miles is 73 microvolts across 50 ohms (-69.5 dbm). This gives a minimum signal to noise ratio of 20 db and a maximum tolerable receiver noise figure of 24.8 db.

Since more than one repeater may be necessary, the following specifications must hold if the system is to be practical:

Power Output	1 watt
Repeater Gain	110 db minimum with AGC
Repeater Noise Figure	14 db
Repeater Bandwidth	1 Megacycle
Spacing Repeater to Repeater	8 Statute Miles (Max)
Spacing Terminal to Repeater	15 Statute Miles (Max)

These specifications will assure a minimum S/N ratio of 19 db throughout the system over isotropic paths. This S/N ratio should prove to be somewhat better in actual systems, since it is anticipated that corner reflectors will be employed at the terminals.

Implementation of "Tobacco Can" is not restricted to radio relay repeaters. Its size makes it readily adaptable to air-droppable beacon transponder service or as a countermeasures device.

A block diagram of this radio relay device is shown in Figure 10 and a proposed packaging scheme is shown in Figure 11.

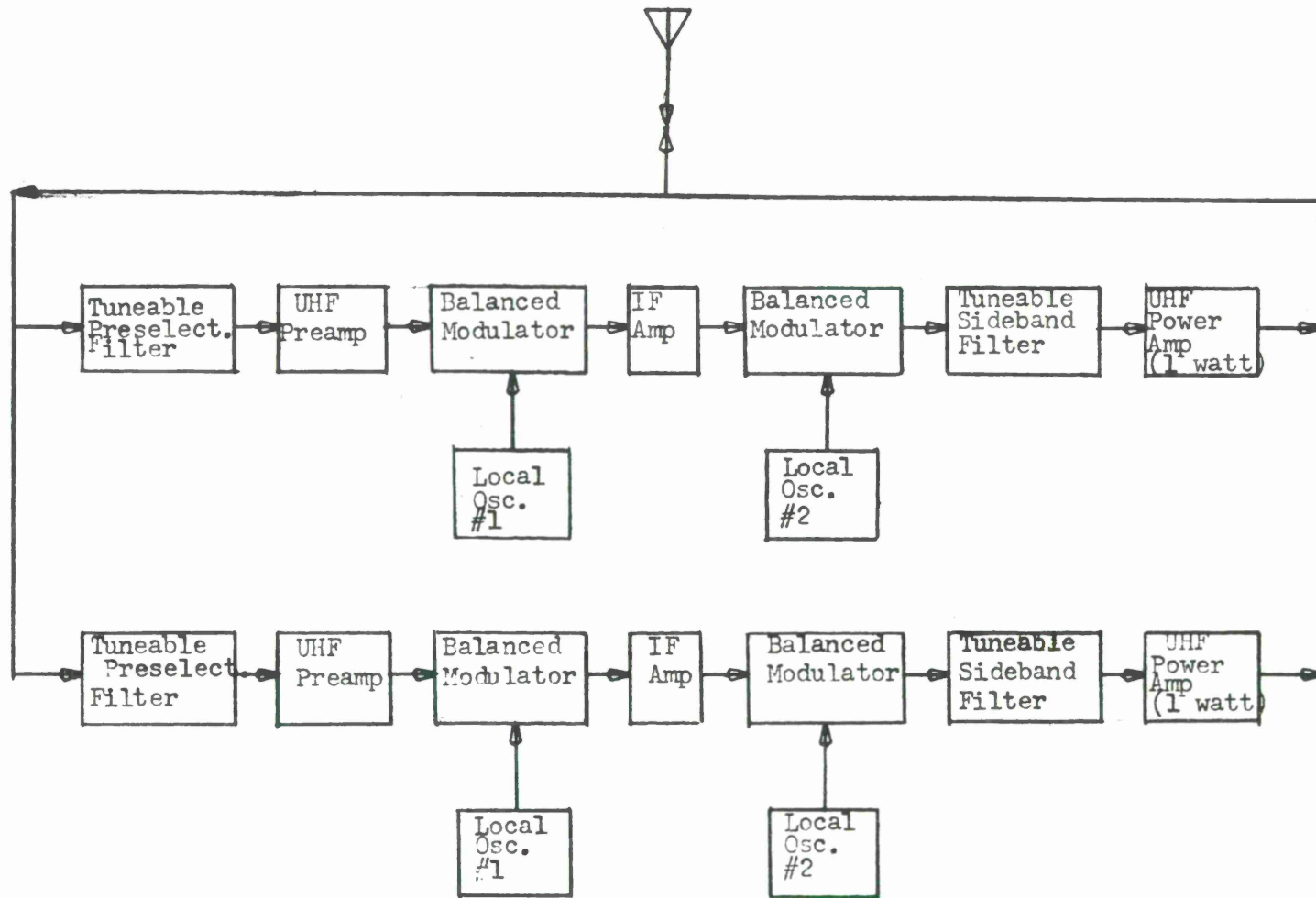

Figure 10. Project Tobacco Can Revised Signal Channel Block Diagram

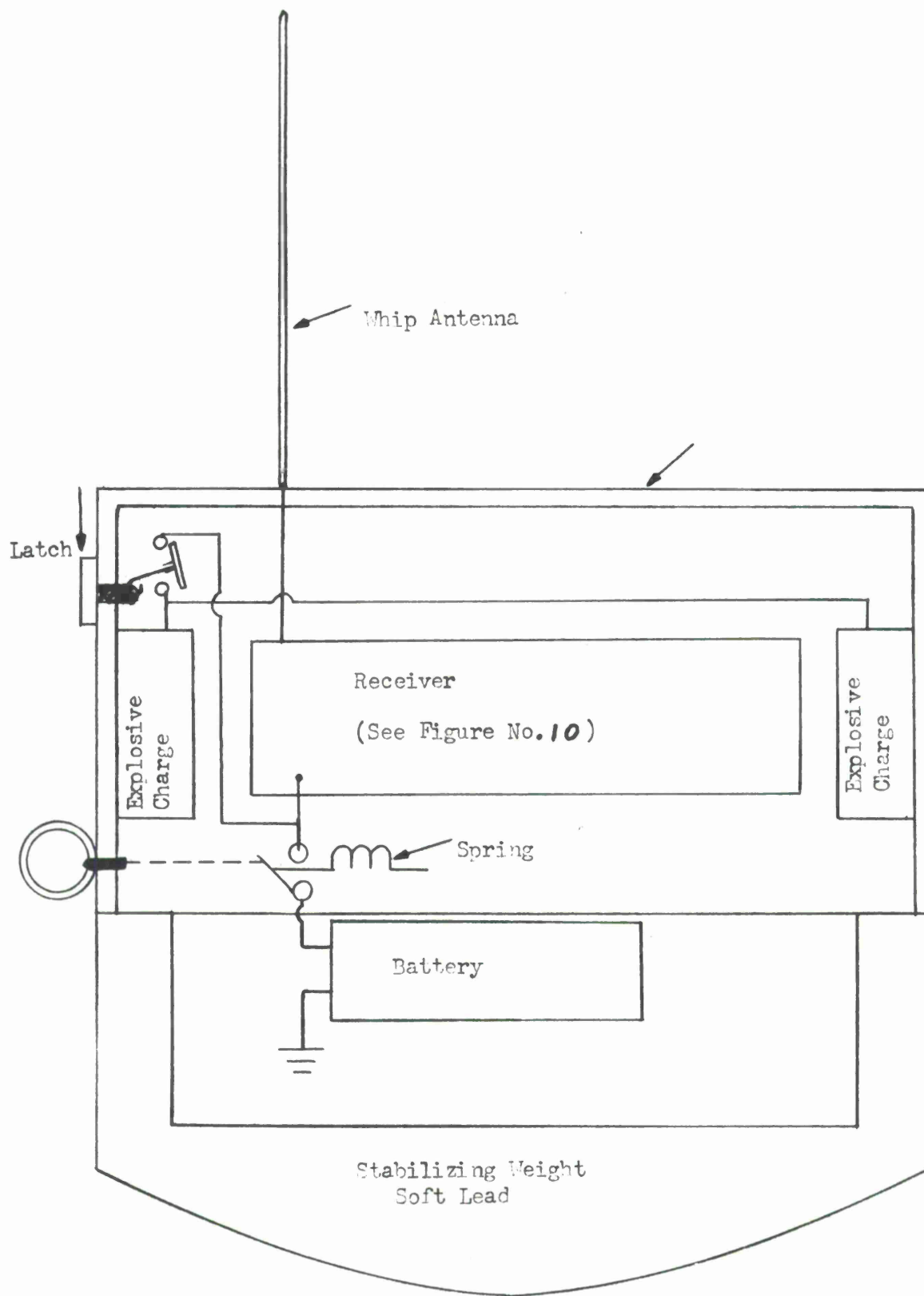

Figure 11. Proposed Configuration, Project Tobacco Can

## 2. Use of Dielectric Immersion to Reduce the Size of Antennas

The velocity of a wave in any medium is given by:

$$V = f\lambda \quad (1)$$

If the wave is electromagnetic and the medium is dielectric:

$$V = \sqrt{\frac{1}{\mu \epsilon}} = \sqrt{\frac{1}{\mu K \epsilon_0}} \quad (2)$$

If the two adjoining media having different dielectric constants are now considered, and if equations (1) and (2) are equated for each medium, the result is:

$$\lambda_1 \sqrt{K_1} = \lambda_2 \sqrt{K_2} \quad (3)$$

Where  $\lambda$  is the wavelength, and  $K$  is the dielectric constant for a particular medium.

If  $K_2$  in (3) is the dielectric constant for free space, the equation can be expressed by:

$$\lambda_1 = \frac{\lambda_2}{\sqrt{K_1}} \quad (4)$$

Thus showing that, for electromagnetic wave propagation in dielectric media, a shortening of the wavelength with respect to that existing in free space at the same frequency is experienced.

If it is now assumed that a radiating source is placed in a dielectric, Snell's Law is expressed:

$$V_2 \sin \theta_1 = V_1 \sin \theta_2 \quad (5)$$

Substituting (2) into (5) results in:

$$\frac{\sin \theta_1}{\sin \theta_2} = \sqrt{\frac{K_2}{K_1}} \quad (6)$$

Under the conditions leading to equation (4), (6) becomes:

$$\frac{\sin \theta_1}{\sin \theta_2} = \frac{1}{\sqrt{K_1}} \quad (7)$$

Total reflection within the source medium occurs when:

$$\sin \theta_2 = 1 \quad (8)$$

Leading to:

$$\theta_1 = \theta_c \quad (9)$$

Where  $\theta_c$  is the critical angle.

Thus:

$$\sin \theta_c = \frac{1}{\sqrt{K_1}} \quad (10)$$

The significance of (10) is based on the fact that, as  $K_1$  increases to values practical for antenna shortening, the critical angle consequently decreases, thus increasing the likelihood of internal reflection in the medium.

In free space:

$$W_R = W_T \frac{G_R G_T \lambda_o^2}{16\pi^2 S^2} \quad (11)$$

thus establishing that received power at an antenna in free space is dependent on the gains of the antennas.

Therefore, utilization of the consequence of equation (10) can be made by placing a  $\frac{\lambda}{2}$  dipole along the focal axis of a parabolic cylinder of dielectric material.

If "A" is the focal length of the parabola and D is the distance across the parabola perpendicular to the focal axis in the plane of the parabola and  $D_1$  is the length of the cylinder along the focal axis, the E and H plane beamwidths

are expressed by:

$$H = \frac{70 \lambda_0}{D \sqrt{K_1}} \quad (12)$$

$$E = \frac{70 \lambda_0}{D_1 \sqrt{K_1}} \quad (13)$$

$$\text{If } D = 4A \quad (14)$$

$$\text{and } D_1 = \frac{\lambda_0}{2 \sqrt{K_1}} \quad (15)$$

and if gain is related to beamwidth by:

$$G = \frac{27,000}{\theta_E \theta_H} \quad (16)$$

$$\text{Then: } G = \frac{11.02 A \sqrt{K_1}}{\lambda_0} \quad (17)$$

If the aperture at the dielectric interface is to be an effective antenna:

$$G \geq 1.64 \quad (18)$$

Equating (17) and (18) yields, then, the minimum focal length of the parabola:

$$A \geq 0.149 \frac{\lambda_0}{\sqrt{K_1}} \quad (19)$$

It is, however, also necessary to analyze the fields at a dielectric interface, in order to improve the efficiency of this configuration.

Maxwell's Equations describe a plane wave propagated along the Z axis by:

$$\text{curl } \epsilon = \frac{\partial \epsilon_x}{\partial Z} = - \mu \frac{\partial H_y}{\partial t} \quad (20)$$

$$\text{curl H} = -\frac{\partial H_y}{\partial Z} = \epsilon \frac{\partial \epsilon_x}{\partial t} \quad (21)$$

If  $H_y = H_0 \sin \omega t$ ,

Then:

$$\text{curl } \epsilon = -\mu \omega H_0 \cos \omega t \quad (22)$$

$$\text{curl H} = \omega \epsilon \eta_0 H_0 \cos \omega t \quad (23)$$

These equations correspond to the form of the differential equations of a transmission line where:

$$L = \mu \quad C = \epsilon$$

At the dielectric interface, a mismatch occurs, causing reflections back into the medium of incidence.

From transmission line theory, the transmitted fields are given by:

$$H_{y1} = \frac{2\sqrt{K_1}}{1+\sqrt{K_1}} H_0 e^{-\gamma_1 Z} \quad (24)$$

$$\epsilon_{y1} = \frac{2\eta_0}{1+\sqrt{K_1}} H_0 e^{-\gamma_1 Z} \quad (25)$$

Where:

$$\eta_0 = \sqrt{\frac{\mu_0}{\epsilon_0}} \quad (26)$$

and the reflected fields are given by:

$$H_{y2R} = -KH_0 e^{-\gamma_2 Z} \quad (27)$$

$$\epsilon_{x2R} = K\eta_0 H_0 e^{-\gamma_2 Z} \quad (28)$$

where:

$$K = \frac{1-\sqrt{K_1}}{1+\sqrt{K_1}} \quad (29)$$

To minimize the reflections, the line can be matched by utilizing an antiresonant matching section. This is expressed by:

$$\eta_o^2 = \frac{L \sqrt{K_1}}{C} \quad (30)$$

if:

$$\mu_1 = \mu_2 = \mu_o = \mu_m = L \quad (31)$$

Then:

$$C = \epsilon_o \sqrt{K_1} = \epsilon_o K_m \quad (32)$$

The meaning of these equations is essentially that, for a maximum energy transfer to the medium in which the antenna is immersed, a  $\frac{\lambda_o}{4\sqrt{K_m}}$  section whose dielectric constant  $K_m = \sqrt{K_1}$  must be inserted between the two media.

Moreover, the focal length of the cylindrical paraboloid shaped dielectric must be  $\frac{\lambda_o}{4\sqrt{K_1}}$  in order to present a match to both antenna and free space. The dielectrics to be used present some practical problems. Materials with sufficiently high dielectric constants seem to be either liquids or ceramics, and these are not directly applicable to the solution of this problem. However, ceramic suspensions in thermoplastic bases appear at this time to be promising.

DISTRIBUTION LIST, AF19(628)-2915 (FINAL REPORT)

ACTIVITY	NR. COPIES
Hq TAC (DCE/Col F. B. Morgan), Langley AFB, Va	1
Hq ESD (ESST-TACS CADRE) L G Hanscom Fld, Bedford, Mass	1
Hq ESD (ESRRG), L G Hanscom Fld, Bedford, Mass	6
Hq ESD (ESTI), L G Hanscom Fld, Bedford, Mass	22*
Hq ESD (ESRR), L G Hanscom Fld, Bedford, Mass	1
Hq AFCS (CSXPRT), Scott AFB, Illinois	2
Hq TAC (DOC), Langley AFB, Va	2
AFCS (FFAS) Southeast Comm Region, Robins AFB, Ga	2
Hq TAC (DORQ), Langley AFB, Va	2
Det 1, 1800 Supp Sq (AFCSRO), L G Hanscom Fld, Bedford, Mass	2
Hq USAF (AFSSA-ES-4), Washington 25, DC	1
Hq AFSC (SCRC/Lt Col Webb), Andrews AFB, Wash DC	2
USARDL (SIGRA/SL-ADT/Tech Dec Ctr) Ft Monmouth, New Jersey	1
USARDL (SIGRA/SL-SUC), Ft Monmouth, New Jersey	1
USN Electronics Lab (ATTN: E Kemp), San Diego, California	1
USA Elec Proving Ground (Tech Library), Fort Huschuca, Ariz	2
Hq USAF (AFMMP), Washington 25, DC	1
Hq USAF (AFOOP/Lt Col Meehan), Washington 25, DC	2
Hq USAF (AFORQ/Lt Col WW Smith), Washington DC	1
Dept of Navy, NATC (NANEP Sr Officer), Patuxent River, Md	1
Hq AFCS (FFRE/Maj Woodward), Scott AFB, Ill	2
AUL, The Air University, Maxwell AFB, Alabama	1
Dept of Army, Offic of Chf Signal Officer, SIGRD-4a-2, Wash DC	1
Dept of Navy, Director, Avionics Div (AW), BuAer, Wash 25, DC	1
Dept of Navy, BuShips, 9670/12, Ser 685B7A-299/Mr Loeb, Wash DC	1
The Rand Corp (USAF Liaison Off), 1700 Main St, Santa Montica Cal	1
USAF Missile Dev Center (MDGRT), Holloman AFB, New Mexico	1
AFCRL (CRIPA), OAR, USAF, L G Hanscom Fld, Bedford, Mass	3
Hq ESD (ESSV), AFSC, L G Hanscom Fld, Bedford, Mass	4
Director, USN Research Lab (Tech Library) Washington 25 DC	1
TOTAL:	70

\*Hq ESD (ESTI) will accomplish distribution of report of DDC.

