

**CLEARINGHOUSE FOR FEDERAL SCIENTIFIC AND TECHNICAL INFORMATION CFSTI  
DOCUMENT MANAGEMENT BRANCH 410.11**

**LIMITATIONS IN REPRODUCTION QUALITY**

ACCESSION #

*AD*  
*603763*

- 1. WE REGRET THAT LEGIBILITY OF THIS DOCUMENT IS IN PART UNSATISFACTORY. REPRODUCTION HAS BEEN MADE FROM BEST AVAILABLE COPY.
- 2. A PORTION OF THE ORIGINAL DOCUMENT CONTAINS FINE DETAIL WHICH MAY MAKE READING OF PHOTOCOPY DIFFICULT.
- 3. THE ORIGINAL DOCUMENT CONTAINS COLOR, BUT DISTRIBUTION COPIES ARE AVAILABLE IN BLACK-AND-WHITE REPRODUCTION ONLY.
- 4. THE INITIAL DISTRIBUTION COPIES CONTAIN COLOR WHICH WILL BE SHOWN IN BLACK-AND-WHITE WHEN IT IS NECESSARY TO REPRINT.
- 5. LIMITED SUPPLY ON HAND: WHEN EXHAUSTED, DOCUMENT WILL BE AVAILABLE IN MICROFICHE ONLY.
- 6. LIMITED SUPPLY ON HAND: WHEN EXHAUSTED DOCUMENT WILL NOT BE AVAILABLE.
- 7. DOCUMENT IS AVAILABLE IN MICROFICHE ONLY.
- 8. DOCUMENT AVAILABLE ON LOAN FROM CFSTI ( TT DOCUMENTS ONLY).
- 9.

PROCESSOR: *[Signature]*

603763

FACTORIAL ANALYSIS OF PRECISION, STEADINESS  
AND EQUILIBRIUM IN FINE MOTOR SKILLS.

ROBERT H. SEASHORE and FRANK J. DUDEK  
Dept. of Psychology, Northwestern University

FINAL REPORT —

O.N.R. Contract N6ori — 158  
Task Order II (N R 151-132)

41 p \$2.00 ea  
\$0.50 mf

**Best  
Available  
Copy**

## Summary

To provide a representative sample of fine motor psychomotor skills emphasizing precision, steadiness, and equilibrium, a battery of eleven laboratory instruments was devised, all having automatic scoring on electric counters. These tests provided a total of twenty-six measurements analyzing such factors as the effect of standing or sitting posture; sense modalities or vision, audition or equilibrium; and movements in two or three dimensions.

The instruments employed and the functions measured were as follows:

Instrument	Functions
Universal Photoelectric Ataxiameter	Control of body sway (static equilibrium), standing or sitting, with or without visual cues, forward-back vs right-left movements.
Arm-hand Ataxiameter	Control of arm-hand stationary position, horizontal and vortical movements.
Photoelectric Target Register	Arm-hand precision in aiming a beam of light at a stationary target.
Straight Tracing	Precision in moving a stylus through a gradually narrowing straight path, toward the body.
Curved Tracing	Precision in moving a stylus over a curved path from right to left.
Rods and Rings (3)	Precision in moving a metal ring over 3 types of rods (straight, sine curve, and tridimensional curve.)
Stylus Thrust	Precision in thrusting a stylus through progressively smaller metal holes at a fixed rate.
Miniature Airplane	Correcting tridimensional movements (turn, bank, climb) of a miniature airplane so as to maintain a straight, level position. (Observer stationary).
Tridimensional Balancing Chair	Similar to Miniature Airplane Test except observer controls turn, bank, and climb movements while in a moving cockpit chair.

The two studies on this project report correlations from three groups of psychology students (N = 39; 100; and 106 respectively) factorially analyzed by separate groups with quite consistent identification of seven group factors underlying precision of motor performances: These factors are identified as follows:

1. Control of body sway, standing position, eyes open or closed, front-back and right-left directions.
2. Control of body sway, sitting position eyes open or closed, especially front-back movements.
3. Control of arm-hand stationary steadiness and aiming, horizontal and vertical movements.
4. Precision of arm-hand movements at slow or medium speed in a restricted plane, e.g., stylus thrusting at a target, or tracing straight or curved paths.
5. Precision in control of a ring moved along the two or more dimensions of a curved rod.
6. Precision in coordination of both hands and right foot in controlling tridimensional movements of a miniature airplane with visual aids.
7. Precision of both hands and right foot in controlling, especially bank and climb movements of a balancing chair cockpit with visual or auditory localization cues.

The instruments were so designed that the tests having the highest loading on factors 1 to 6 could later be combined into a portable battery of six tests for use in military projects on ships, planes, shore stations, or laboratories. Circuits from the balancing chair have been modified to permit their use as auxiliary equipment on a standard Link Trainer so that they can be used to provide standardized tests of dynamic equilibrium as well as their normal uses as training devices.

Suggestions for further research outline the following possible uses of the instruments:

1. Selection of operators for training in the operation of complex

tools, weapons or machines calling for precision, steadiness or equilibrium. This battery should supplement psychomotor measures of speed and precision at high speed such as those employed by the A.A.F., in selection of air crew members. Selection of industrial personnel for complex manual skills should also be investigated.

2. Employment of these tests as one set of criteria in determining the effects upon human working efficiency of factors such as extremes of temperature, humidity, air conditioning, motivation, fatigue, age, drugs, and similar factors.
3. Varying the present tests for more detailed analysis of the effects of changing sense modalities and stimulus patterns; musculatures employed; and patterns of action or work methods.

FACTORIAL ANALYSES OF PRECISION, STEADINESS AND EQUILIBRIUM  
IN FINE MOTOR SKILLS\*

Robert H. Seashore and Frank J. Dudek  
Northwestern University

Psychomotor skills or sensorimotor coordinations may be classified with respect to their emphasis on three aspects, speed, strength, and precision. The analyses of motor skills emphasizing speed and precision at high speed are now quite numerous<sup>7, 8, 9</sup> and were of great importance in the Army Air Force Air Crew Selection Program.<sup>3, 5</sup> Measures emphasizing strength are usually gross motor performances such as athletic skills and have been studied very extensively by McCloy<sup>4</sup> and other specialists in physical education. Measures emphasizing precision such as those of tremor, arm or body sway, equilibrium and accuracy in slow-speed movements have received far less attention than skills emphasizing either speed or strength, but are summarized by Seashore and Adams<sup>6</sup> and Seashore, Dudek and Holtzman.<sup>10</sup>

---

\*This is the final report under ONR Contract 158-Task Order II (NR 151 132). The opinions expressed are those of the writers and not necessarily those of the Office of Naval Research.

Preliminary development of the tests was assisted by grants-in-aid from the Northwestern University Research Council and from President Emeritus Walter Dill Scott. Technical assistance in the design and construction of the instruments was given by Messrs. J.R. Zweizig, H. Coopmans, M. Astrahan, J. Brubaker, L.E. Nelson, Wm. Knowles, and by our faculty colleagues J.F. Calvert, L.T. Wyley, A.A. Bronwell and R.W. Jones in the Northwestern Institute of Technology. Mr. R.D. Malm of Clayton Mark & Co. Steel Mfg., (Evanston) and Mr. Fred Duer of Chicago were of great assistance in the tubular steel construction of the tridimensional balancing chair. Since the development of the instruments was carried on over a period of twenty years it is possible to acknowledge only in a general way the assistance of many other co-workers on earlier related projects.

Photographic cuts of the instruments used have been loaned by courtesy of the Editor of the Northwestern Engineer, from an article by J.R. Zweizig.<sup>13</sup>

In order to determine the nature and interrelations of factors in motor skills emphasizing precision the writers assembled a large battery of motor tests for the measurement of steadiness, equilibrium and precision in slow and medium speed movements, including a considerable number of new instruments designed to sample each of the principal types of precision found in practical motor skills. Since these tests were too numerous to be administered conveniently to a single group of subjects for factorial analysis they were divided into two batteries. The first of these batteries, consisting of seven tests measuring precision in arm-hand steadiness, arm-hand aiming, tracing a stylus through straight and curved pathways, and moving a ring along straight and curved rods, was analyzed factorially by Seashore, Dudek and Holtzman as the first study in this project<sup>10</sup> and found to be describable in terms of three factors typified by (1) arm-hand stationary steadiness, (2) precise movement in a single plane as in stylus tracing, and (3) precise movement in two or more planes as in moving a ring along an irregularly curved rod.

The present experiment includes each of the tests having the highest loading on one of the above-mentioned factors, namely arm-hand steadiness, straight path stylus tracing, and three dimensional rod and ring manipulation. In addition, representative samples of the remaining types of precise motor skills were included as follows, (1) control of body sway, eyes open and eyes closed, in both sitting and standing positions; (2) a tridimensional pursuit task, the Miniature Airplane Test, emphasizing the coordination of moderate speed movements (roughly comparable to those of piloting a plane in rough air, except that no standard type of airplane controls were used); and (3) the balancing chair tridimensional pursuit task comparable to the Miniature Airplane Test except that the observer was seated in a chair which moved like the cockpit of an airplane and was to

be kept as nearly as possible on a level plane and pointed straight ahead. This was done first with eyes open and then with eyes closed, substituting an auditory localization cue from a small loudspeaker directly in front of the chair.

The present battery thus included measures of controlling body sway both standing and sitting, and with and without visual cues; arm-hand steadiness in stationary position; arm-hand precision in relatively slow stylus and ring manipulations; moderate speed coordinations of both hands and the right foot in "piloting" the miniature plane, and the same type of piloting performance when changes in bodily equilibrium were superimposed.

In order to minimize fatigue and to fit in with the available time schedules of student subjects the tests were administered over a period of three days according to the following plan.

#### Administration of the Tests

- Session 1: The Universal Ataxiameter, the Arm-Hand Ataxiameter, the Straight Tracing Test, the Rod-and-Ring Test. For each test there was a practice trial followed by 6 trials which were recorded. The measures used for intercorrelations were the sum of the scores on these six trials. The length of each trial was:
- |                         |                |
|-------------------------|----------------|
| Universal Ataxiameter-- | <u>15 sec.</u> |
| Arm-Hand Ataxiameter--- | <u>15 sec.</u> |
| Straight Tracing Test-- | <u>12 sec.</u> |
| Rod-and-Ring Test-----  | <u>17 sec.</u> |
- Session 2: The Miniature Airplane Test. This measure consisted of a practice trial followed by sixteen test trials (or cycles). This was necessary because of learning apparent in the initial trials. Each cycle was 95 seconds long. The scores used for interrelations were the sum of the last three trials; (i.e., cycles 14, 15, and 16.)
- Session 3: The Balancing Chair Test. The order of administration for this test was to have a practice trial followed by 9 test trials with the eyes open. Following this there was a test trial with the eyes closed followed by 6 test runs with the eyes closed. The sum of the last three trials for each condition were the scores used for intercorrelations. Each trial was 60 seconds long.

## Description of Instruments

1. Universal Photoelectric Ataxiometer. This instrument was designed by Seashore to measure the total movement of either the body or hand in two dimensions simultaneously. As shown in Figure 1, when used to measure body sway in sitting position, the observer wears a light headgear to which threads are attached and run over small ball bearing pulleys at each end of the horizontal arm of the instrument to separate wheels inside the central box. Each of these wheels consists of a thin celluloid disc on which are inscribed radial lines at intervals of 4 degrees. The thread from the observer's head is coiled around a pulley on the shaft of the wheel so that any movement of the observer will rotate the wheel against a light spring tension. A beam of light focused through a slit in front of the wheel is interrupted whenever a dark radial line of the wheel passes in front of the slit, thus controlling impulses of light to a photoelectric cell which in turn controls electrical impulses going to an amplifier, and thence to a counter, as shown in the accompanying wiring diagram, (Fig. 7).

Since the threads are all arranged at right angles, one of them registers all forward-back movements while the other measures all right-left movements on the counters. The height of the telescoping vertical standard is adjustable for the various heights of either standing or sitting observers. Calibration of the accuracy of the recording system is easily checked by placing the ring to which the two threads are attached, on a pin inserted on a small crank wheel which is mounted on the central box and which can be moved through 360 degrees, thus providing a standard amount of movement for each thread to be checked against each counter.

The horizontal arm of the Universal Ataxiometer may also be moved 45 degrees and the ball bearing pulleys rotated 90 degrees so that the



1

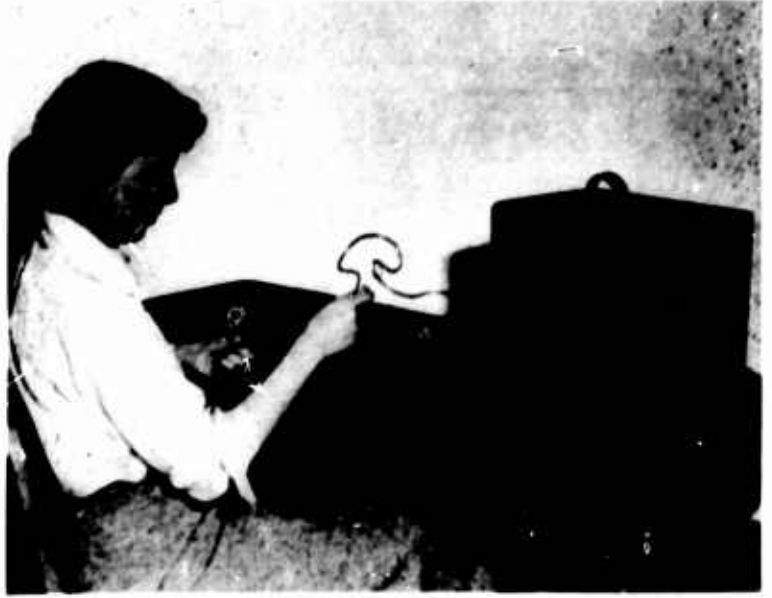

4



2

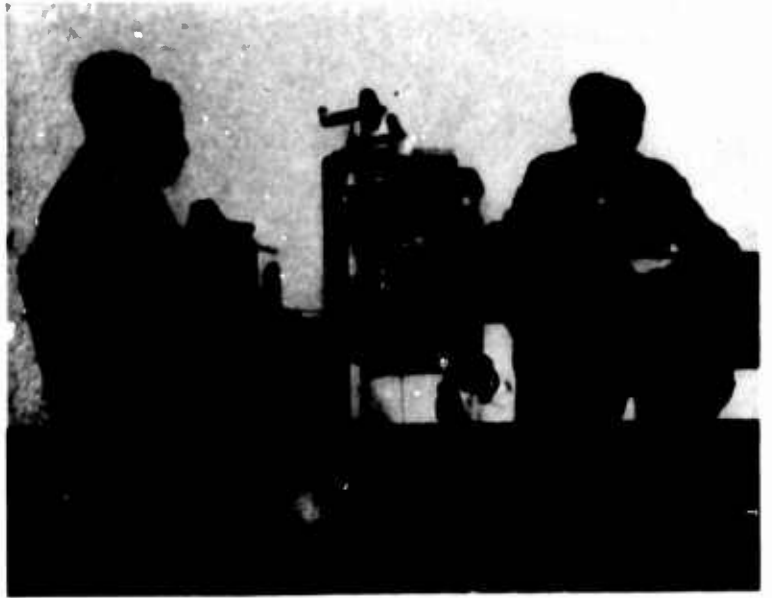

5



3



6

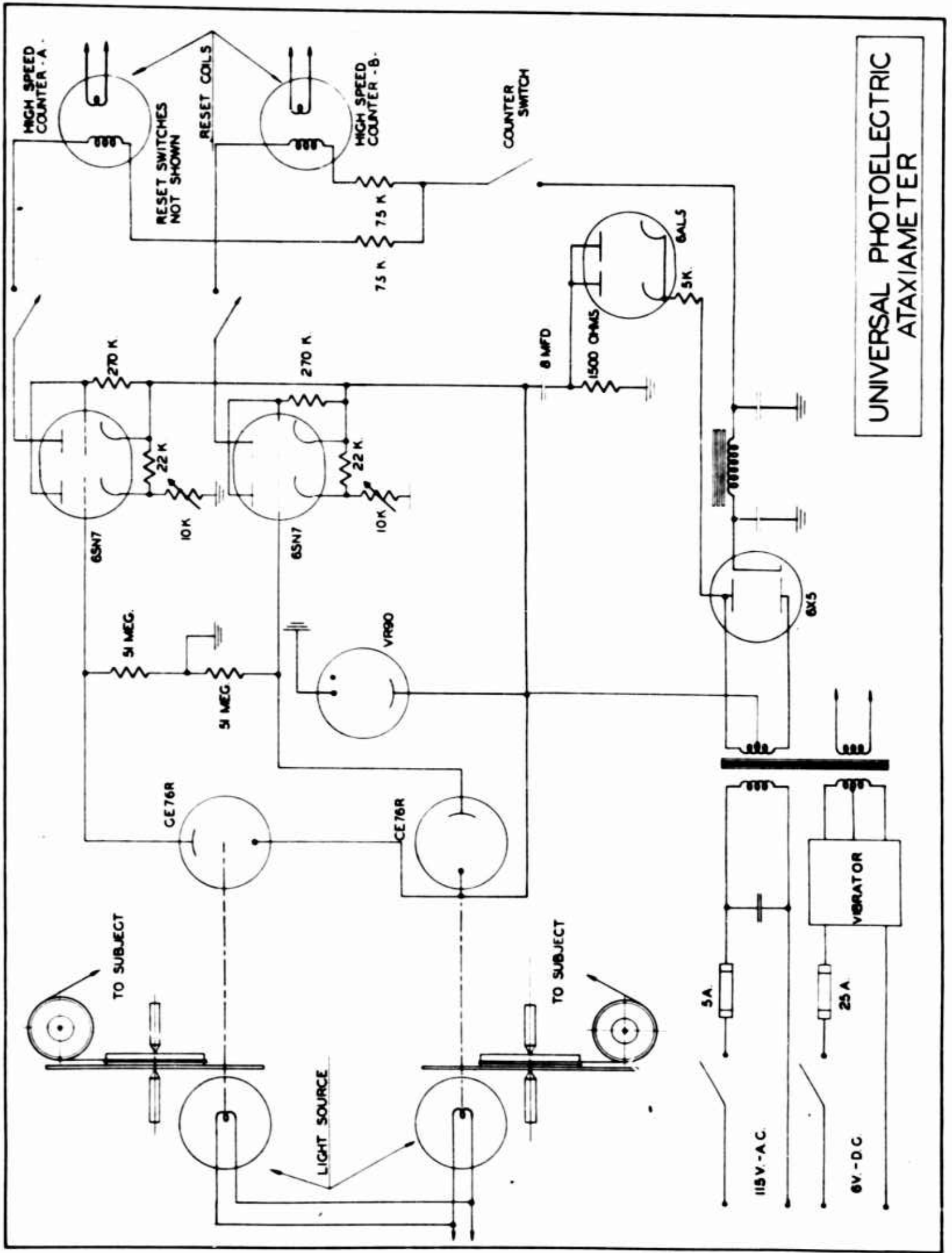

UNIVERSAL PHOTOELECTRIC  
ATAXIOMETER



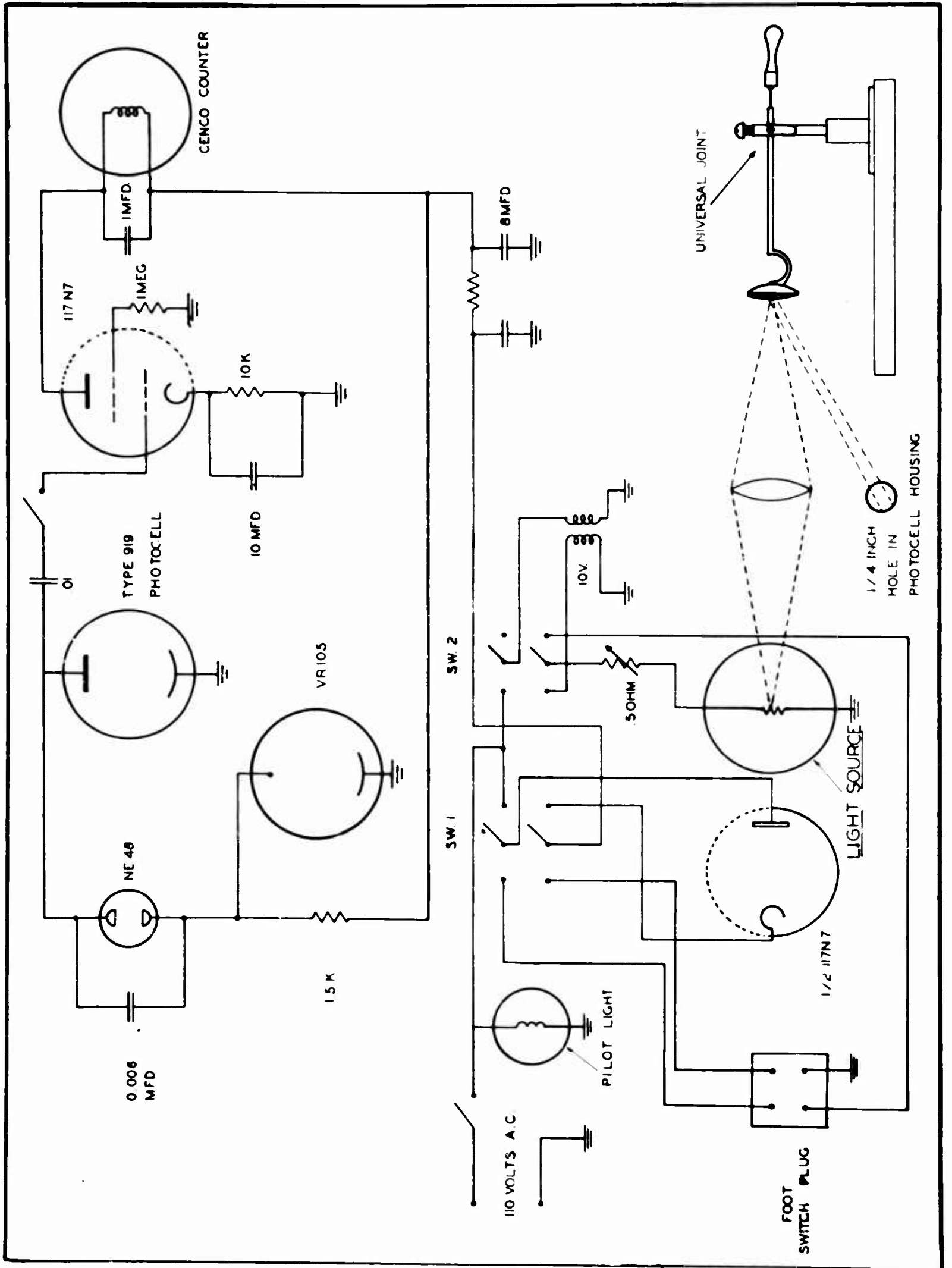

0.006  
MFD

NE 40

TYPE 919  
PHOTOCELL

117N7

CENCO COUNTER

10 MFD

10K

VR105

15 K

110 VOLTS A.C.

PILOT LIGHT

SW.1

SW.2

10V

50 OHM

LIGHT SOURCE

1/2 117N7

FOOT  
SWITCH  
PLUG

UNIVERSAL JOINT

1/4 INCH  
HOLE IN  
PHOTOCELL HOUSING



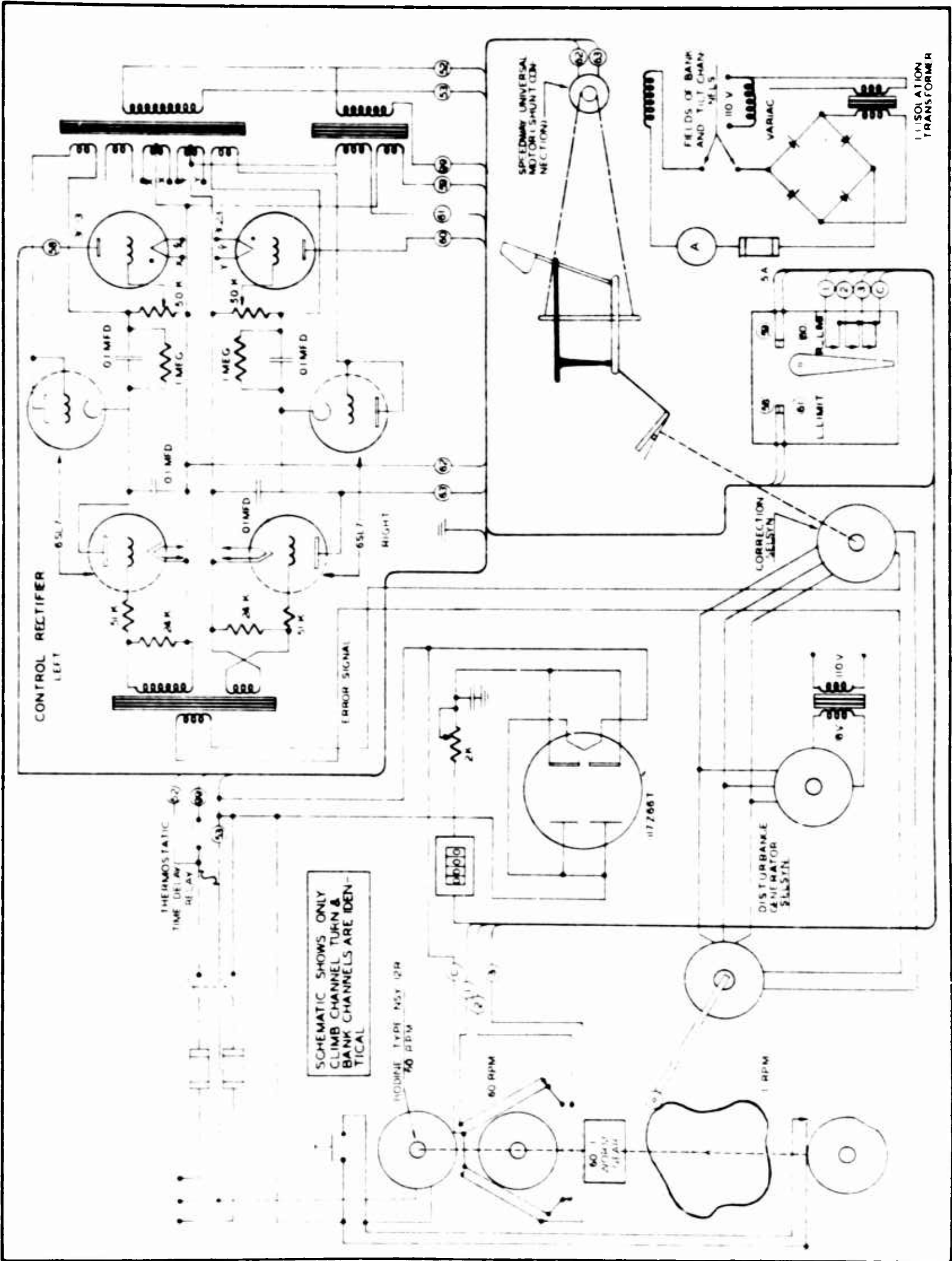

CONTROL RECTIFIER  
LEFT

6SL7

6X4

6X5

6X6

6X7

6X8

50K

1MEG

50K

1MEG

50K

1MEG

50K

1MEG

50K

1MEG

50K

1MEG

50K

1MEG

50K

1MEG

THERMOSTATIC  
TIME DELAY

62

60

53

60

60

SCHEMATIC SHOWS ONLY  
CLIMB CHANNEL TURN &  
BANK CHANNELS ARE IDENTICAL

INDUPE TYPE MSY (2H  
70 RPM

60 RPM

60 RPM

60 RPM

60 RPM

60 RPM

60 RPM

60 RPM

60 RPM

60 RPM

SPEEDWAY UNIVERSAL  
MOTOR (SPUN TORN)

62

63

64

65

66

67

68

69

70

71

72

73

74

75

76

77

78

79

80

81

82

83

84

85

86

87

88

89

90

91

92

93

94

95

96

97

98

99

100

101

102

103

104

105

106

107

108

109

110

111

112

113

114

115

116

117

118

119

120

121

122

123

124

125

126

127

128

129

130

131

132

133

134

135

136

137

138

139

140

141

142

143

144

145

146

147

148

149

150

151

152

153

154

155

156

157

158

159

160

161

162

163

164

165

166

167

168

169

170

171

172

173

174

175

FIELDS OF BATH  
AND TILT CHAN  
NELS

110 V

VARIAC

110 V

110 V

110 V

110 V

110 V

110 V

110 V

110 V

110 V

110 V

110 V

110 V

110 V

110 V

110 V

110 V

110 V

110 V

110 V

110 V

110 V

110 V

110 V

110 V

110 V

110 V

110 V

110 V

110 V

110 V

110 V

110 V

110 V

110 V

110 V

110 V

110 V

110 V

110 V

110 V

110 V

110 V

110 V

110 V

110 V

110 V

110 V

110 V

110 V

110 V

110 V

110 V

110 V

110 V

110 V

110 V

110 V

110 V

110 V

110 V

110 V

110 V

110 V

110 V

110 V

110 V

110 V

110 V

110 V

110 V

110 V

110 V

110 V

110 V

110 V

110 V

110 V

110 V

110 V

110 V

110 V

110 V

110 V

110 V

110 V

110 V

110 V

110 V

110 V

110 V

110 V

110 V

110 V

110 V

110 V

110 V

110 V

110 V

110 V

110 V

110 V

110 V

110 V

110 V

110 V

110 V

110 V

110 V

110 V

110 V

110 V

110 V

5A

50

100

150

200

250

300

350

400

450

500

550

600

650

700

750

800

850

900

950

1000

1050

1100

1150

1200

1250

1300

1350</

upper end of the rod registers all vertical movements of the hand while the lower end of the rod measures all horizontal movements simultaneously. These adjustable features of the instrument adapt it for a variety of purposes at practically no extra cost. The instrument is also designed for portability so that it can be taken to factories or military locations such as ships and planes. For use in the field, an alternative circuit employing a 6 volt battery may be substituted for the 110 volt alternating current source employed in the laboratory.\*

The spoked disc was so constructed that a movement of one centimeter on a thread gives 25 units on the counter. For finer movements a disc having a larger number of spokes could provide still finer units of measurement.

2. The Arm-Hand Ataxiometer (Sway Integrator). For extensive work in the laboratory where it might not be convenient to change the Universal Ataxiometer from the body sway to the hand sway positions for each cycle of tests, a specialized instrument designed to measure only arm-hand movements was provided. Instead of using a thread from the finger to the spoked wheel of the photoelectric mechanism, a lever mounted on a universal joint was attached to two other levers inside the instrument, one registering vertical and the other horizontal movements. These light-weight levers having spokes on photographic film at an angle of 0.33 degrees (between spokes) constitute sectors of a spoked wheel, but greatly reduce the weight as compared to a full circle. An amplifier and a 4-to-1 scaling circuit were employed to operate high speed electric counters. (See wiring diagram Fig. 8 of Sway Integrator.) An observer's hand movement of one centimeter produced a registration of 3 units on the counter. The small ball and socket joint near the observer's finger tip prevents him from steadying himself by -----

\* This instrument was constructed by the Nelson Instrument Company of Chicago from the general specifications supplied by Seashore.

placing pressure on the finger tab.

3. Photoelectric Target Register. This instrument, employed but not fully described in our first study<sup>10</sup> differs from the two staximeters previously described in that it cumulates the length of time at each degree of error from a central aiming point whereas the other two devices measure only distance moved. The basic mechanism shown in Fig. 3, consists of a light source projecting a beam of light to a mirror mounted on the end of a light tubular lever having a reduction of 2-to-1 and mounted in a universal joint so that it can move vertically and horizontally. The beam of light reflected from the mirror is approximately the same size as an opening at the left of the instrument which admits the light to a photoelectric cell inside the box. As shown in the wiring diagram of Fig. 10 the photoelectric cell is used as a resistance unit to control the rate of an oscillating circuit which varies from slightly above zero to ten per second, depending upon the amount of light entering the opening in front of the photocell. Calibration of the instrument was accomplished by varying the intensity of the light source (of wiring diagram fig. 10).

In addition to the universal joint mounting of the lever at the end nearest the instrument a pin is inserted in the end of the lever to permit slight forward and back movements and is attached to a ball and socket joint on the finger tab which prevents the observer from exerting pressure in any direction as an aid to steadiness. The length of the lever has also been varied in a study by Forsberg<sup>1</sup> on the effect of increased difficulty of a task in relation to the reliability of measurement of individual differences in the test. The actual sizes of the light beam and the lever were originally chosen so as to make the average score of observers produce approximately half the maximum rate of count.

4. Stylus Tracing Tests. As shown in Fig. 4 the straight path stylus tracing test is similar to the original device of Whipple in providing a slightly V-shaped slot 12 inches long, varying in width 6 millimeters at the finishing end. Small circular spaces are provided at each end to permit easy insertion and withdrawal of the stylus. The device differs from the original Whipple instrument in four important respects: (1) the slot is constructed as the top of a box so that the stylus does not rest on the bottom during movement, thus eliminating an aid to steadiness; (2) the all-metal stylus is not wired to the counter directly but instead employs a low magnitude current passing through the observer's body to the left hand which grasps another metal handle leading to the 6-V 60 cycle source; (3) instead of measuring the distance moved before the first contact, our procedure employed a circuit measuring the total time of contact during the approximately 12 seconds passage of the stylus through the slot. This was accomplished through the use of 60-cycle current which operated a Potter electronic counter as a timing device; (4) a series of five lights spaced at intervals along the slot are turned on in sequence to set the standard rate at which the stylus should move. However, this feature was developed after the conclusion of the experiment.

Another form of the test employed a curved pathway having a width of 0.4 centimeter. The width of this pathway is adjustable by means of screws in case it should be desirable to make the task easier for younger subjects. Although either the straight or curved pathways could be used in any dimension, in our experiment both were used for horizontal movements, the straight path for movements toward the body and the curved path for movements from left to right.

4. The Rod and Ring Manipulation Tests. Since Seashore, Buxton and McCollom<sup>9</sup> had previously found that measures of tapping in one plane represented one factor while measures of tapping in two planes represented another semi-independent factor of speed skills, it seemed desirable to investigate the importance of using one, two or three dimensions for measurement of precision in arm-hand movements. To accomplish this, three 3/8" diameter brass rods were employed, one straight, one having a vertical sine wave, and the third having curves in both horizontal and vertical planes as well as movements from left to right. The task consisted of manipulating a small knob on which was mounted a ring 5/8" in diameter so that it did not touch the rod while being moved at a standard speed from left to right. Scores were obtained from a Potter electronic counter operated from a 60-cycle, 110 volt, AC source so as to provide a cumulative time measure in units of 120 per second.

When it was shown by Seashore, Dudek and Holtzman<sup>10</sup> that scores on the three dimensions were moderately correlated and constituted a separate factor among steadiness tests, a new and smaller model of the tridimensional test was designed for use in a portable battery (cf. Fig. 4). In this, as in the stylus path tracing test, no encumbering wire is attached to the ring since the low magnitude passes through the observer's body to another metal handle held in the left hand.

5. The Tridimensional Pursuit Test. This instrument also known as the Miniature Airplane Test was originally designed by Seashore, Van Dusen and Brackett in order to combine the optimal features of an ideal test for the selection of airplane pilots. These specifications grew out of a conference at Maxwell Field in September 1941, at which John Flanagan, Arthur Melton, Robert Rock, Lawrence Shaffer and Seashore reviewed the available motor skills

tests which were later incorporated in the AAF Pilot Selection Program. These specifications included the following details: (1) stimulus cues should all come from a single source, in this case the miniature airplane, approximately 4 inches long, instead of from separate rows of lights as on the Mashburn test; (2) scoring should be in degrees of error, that is, duration multiplied by distance rather than an "all or none", or "on-off" criterion. (3) The movements called for should be in three dimensions but in order to minimize either positive or negative transfer from previous experience with airplanes, an entirely different type of controls was provided.

As shown in Fig. 5, the left hand horizontal lever steers the miniature airplane horizontally by means of a ball-chain connected to a pulley on the central shaft supporting the airplane. The right hand vertical lever similarly controls banking movements of the plane by a ball-chain which runs from a pulley directly underneath the center of the hollow shaft supporting the plane. The fact that the ball-chain can rotate as well as turn in any direction permits banking movements of the wings independently of and simultaneously with the horizontal turning movements and the elevation or dive-climb movements on the head-tail axis. These head-tail movements are in turn controlled by a pedal operated by the right foot. As originally constructed a substitute set of controls employing an airplane stick and rudder and bar could be attached to the main apparatus to study transfer from one type of controls to the other. Evidences for the validity of this instrument for the selection of pilots are to be published by Van Dusen. The original instrument was also used in a study directed by Ivy and Seashore for the measurement of the effectiveness of analeptic drugs in relieving fatigue from prolonged military operation, and give significant results in this situation.

The stimulus pattern is provided by the standardized cycle of movements of the plane which are produced by two irregular cams, one to control dive-climb movements and the other to control both turning and banking movements, since these are normally coordinated in flying a plane. Actually, the manual controls operated by the observer counteracted the disturbing movements induced by the cams so nearly that a perfect score would mean that as soon as any movement was induced by the cam it was corrected by the appropriate manual or foot control. Since most scores were in between random and perfect and improved with practice, the actual movements of the plane seen by the observer were never the same and hence did not become a routine series of responses which could be anticipated. The original cycle of the cams lasted one and one-half minutes before repeating while that of the revised model lasts 95 seconds.

In order to measure the durations of each degree of error in controlling one dimension of the plane's movement, a rotary switch plate was devised as shown in Fig. 10. Whenever the plate was rotated 6 degrees the first brush made contact with the brass plate and completed the circuit through a commutator which registered two units per second. If the switch plate rotated as far as 12 degrees from neutral, the center brush made contact and counted another two units per second on the counter while if the error increased as far as 18 degrees, the third brush completed its circuit to the commutator for another two counts per second. In this way it was possible to register four degrees of error, 0, 2, 4, or 6 counts per second for errors in either direction. By this means, an integrated time-error score was recorded on separate counters for each of the three dimensions of movement.

Calibration was provided by locking the chains from the control levers in neutral position and running the cams through the complete cycle. This

gave a score of maximum error without the use of manual controls as a check to insure the proper functioning of the entire instrument.

6. The Tridimensional Balancing Chair. In order to simulate more nearly the complex task of maintaining level straight flight in an airplane during rough weather conditions, a Tridimensional Balancing Chair was constructed (cf. Fig. 6). The rotational movements of this chair, in three dimensions, corresponded to turning, banking and diving or climbing movements in an airplane cockpit but, of course, could not simulate horizontal or vertical movements of the plane as a whole. This chair was designed to add the factor of changing equilibrium to the task of three-dimensional controls presented by the miniature airplane test.

Although the Link trainer provides a somewhat similar situation, except that it is designed for training in blind flying by the use of instruments, this trainer was not available to us during the war and also appeared to be a good deal more complicated than was necessary for possible use as an aptitude test for the selection of candidates for pilot training. As shown in Fig. 6, the chair is mounted on a central pedestal which is offset to the back in order to provide clearance for movements of the foot support. The horizontal support at the level of the chair arm was mounted so as to permit a banking movement while the axis on the chair arms permitted dive-climb movements. As in an airplane, all three dimensions of movement could be changed independently or simultaneously.

Because of the greater mass to be moved, including the observer's own body weight; electrical controls (cf. Fig. 11) were substituted for the mechanical controls employed on the miniature airplane test. This was done in order to minimize tactual and kinesthetic cues which would be provided by the feel of

the control levers if mechanical controls were employed. This point however is debatable and it would be interesting to compare scores with mechanical and electrical controls. The type of control employed was that of a Selsyn motor pair, one unit on each manual or pedal control and the other unit of the pair on the cams which controlled the reversible motors to tilt or turn the chair. The Selsyn operated by the manual control could either neutralize or reverse the direction of the motor which actually moves the chair. As in the miniature airplane task the instructions were to keep the instrument level and pointed straight. Under blindfold conditions, used to emphasize the importance of cues from the sense of equilibrium, a pure tone produced by an oscillator and speaker mounted directly in front of the observer provided horizontal orientation.

## Results

Twenty-one variables were measured utilizing the instruments previously described. These measures were then intercorrelated and Pearsonian product moment  $r$ 's were determined. The matrix of intercorrelations is presented in Table 1. The numbers identifying the variables are shown below.

No.	Type of Test	Instrument
Body Sway---		
1.	Standing, eyes open, right-left component	Universal Ataxiameter
2.	Standing, eyes open, front-back component	
3.	Standing, eyes closed, right-left component	
4.	Standing, eyes closed, front-back component	
5.	Sitting, eyes open, right-left component	
6.	Sitting eyes open, front-back component	
7.	Sitting, eyes closed, right-left component	
8.	Sitting, eyes closed, front-back component	
-----		
Arm-Hand Steadiness		
9.	Horizontal motion	Arm-Hand Ataxiameter
10.	Vertical motion	
-----		
Slow Movements		
11.	Straight-tracing	Straight Tracing Test
-----		
12.	Rod-and ring, three dimensional tracing	Rod and Ring Apparatus
-----		
Complex Motor Coordination		
13.	Eyes open, turn	Tridimensional Balancing Chair
14.	Eyes open, climb	
15.	Eyes open, bank	
16.	Eyes closed, turn	
17.	Eyes closed, climb	
18.	Eyes closed, bank	
-----		
19.	Turn	Miniature Airplane
20.	Climb	
21.	Bank	
-----		

The intercorrelations in this matrix are nearly all positive or zero. The few negative coefficients noted do not seem to differ appreciably from zero (the N's on which the intercorrelations are based vary from 103 to 106, college students in Psychology, 80 men and 27 women). This matrix of intercorrelations was factorially analyzed utilizing the centroid method as described by Guilford.<sup>2</sup> Table 2 presents the centroid and rotated factor loadings for the various variables, and the estimated and computed communalities. The communalities are estimates of the common factor variance associated with each variable. The fact that the communalities are, in general, fairly high tends to indicate that these measures can be considered as fairly reliable indices. Previous investigations<sup>10</sup> tend to support the conclusion that these measures have no more than about 20% "error variance", depending on the manner in which one chooses to interpret degree of error involved. Since the main problem of this study is not to demonstrate the intrinsic reliabilities of the various measures, most of this having been done elsewhere,<sup>12</sup> but rather to show the interrelationships and "communality" among the various measures, the reliabilities are not presented per se. However, there seems little doubt that most of the measures are sufficiently consistent indices from which to determine factorial patterns which might be present in these data.

Six factors were extracted from the matrix before the residuals and factor loadings were considered to show no more common factor variance. These six factors were then rotated with criteria of simple structure and positive manifold in mind. The rotations were carried out maintaining orthogonal axes and were done graphically utilizing the method described by Zimmerman.<sup>10</sup>

TABLE 1.

Intercorrelations Among the 21 Variables Comprising the Steadiness Battery.  
(N 106)

	1	2	3	4	5	6	7	8	9	10	11	12	13	14	15	16	17	18	19	20	21
1.																					
2.	609*																				
3.	710	471																			
4.	544	684	617																		
5.	619	409	537	391																	
6.	332	571	247	393	604																
7.	625	412	460	359	821	549															
8.	453	580	327	476	667	828	686														
9.	478	337	372	274	521	363	432	433													
10.	319	329	343	229	385	310	293	277	735												
11.	415	337	299	357	098	131	228	217	371	309											
12.	190	211	121	197	156	177	172	242	206	150	350										
13.	203	166	158	140	113	230	124	254	031	-052	-020	044									
14.	116	-007	013	032	-051	126	-029	074	-127	-174	-121	146	197								
15.	061	106	069	192	-012	166	-011	156	-096	-089	-021	191	184	566							
16.	252	196	274	169	169	281	163	238	140	-014	-065	183	231	351	294						
17.	176	193	142	180	134	151	000	120	101	000	-120	088	169	410	482	316					
18.	104	132	006	127	028	143	002	118	-044	-080	002	144	315	428	693	324	531				
19.	003	-242	-130	-239	121	043	046	090	021	-046	-010	118	325	275	201	174	110	255			
20.	-012	-160	099	-131	063	032	-052	-059	015	050	004	172	177	187	121	267	014	159	272		
21.	049	-044	-026	057	114	175	098	180	146	125	129	-005	245	238	224	053	188	290	420	129	

\* DECIMAL POINTS HAVE BEEN OMITTED.

TABLE 2.

Factor Loadings and Communalities of Variables in Steadiness Battery.

	Centroid Loadings						Rotated Loadings						$h^2$	$h^2 r$
	I	II	III	IV	V	VI	I	II	III	IV	V	VI		
Universal Attentiveness	712*	-339	238	-130	195	196	77	80	363	150	060	135	77	
rt-left eyes open 1.	610	-404	345	223	-189	-061	74	74	174	377	263	-197	74	
for-back eyes open 2.	582	-329	257	-117	286	248	67	65	290	060	-010	087	67	
rt-left eyes clos. 3.	576	-333	427	096	-178	052	67	65	110	417	220	-102	67	
for-back eyes clos. 4.	676	-395	-303	160	284	156	84	80	460	-230	-061	169	83	
rt-left eyes open 5.	668	-203	-243	428	-136	-060	75	75	232	-015	268	085	75	
for-back eyes open 6.	615	-427	-210	178	123	230	70	70	325	-080	-100	136	70	
rt-left eyes clos. 7.	727	-285	-234	397	-223	081	88	83	200	085	173	151	87	
for-back eyes clos. 8.														
Arm-Steadiness (horizontal)	548	-401	-229	-329	143	-311	74	71	810	116	000	070	73	
(vertical)	415	-402	-202	-361	054	-438	70	70	795	201	000	-030	68	
Straight Trace	355	-250	132	-469	-396	067	59	62	260	652	-095	228	59	
Three-dimensional Trace	349	044	107	-180	-120	114	20	20	077	236	110	255	19	
Eyes Open	352	256	-112	058	-101	158	24	25	-058	005	210	380	23	
Turn 13.	318	587	139	097	117	-031	49	49	-127	-165	562	299	47	
Climb 14.	417	579	280	172	-055	-175	65	65	-134	020	755	197	64	
Bank 15.	437	283	077	082	250	123	36	33	015	-212	340	281	35	
Turn 16.	384	383	223	186	188	-280	49	40	061	-150	654	025	48	
Climb 17.	438	612	175	147	-078	-150	65	65	-116	000	727	290	63	
Bank 18.														
Miniature Airplane	234	481	-445	-178	-084	184	56	51	010	-120	094	692	56	
Turn 19.	165	321	-165	-238	134	195	27	28	037	-136	025	468	26	
Climb 20.	314	288	-305	-084	-189	-124	33	32	164	047	250	395	30	
Bank 21.														

\* Decimal points have been omitted.

## Discussion

The results of this study tend to confirm, in general, previous results<sup>10</sup> which indicated that the intercorrelations among tests of "steadiness" cannot be explained adequately by postulating a single underlying "steadiness" factor. From the matrix of intercorrelations resulting for this battery of measures six factors were extracted. Examination of the rotated factor loadings suggests what these factors are and indicates further that the factors are correlated to some extent. Before discussing the relationships among the factors each will be considered separately in terms of the variables associated with it.

Factor I. The variables with the highest loadings in this factor are the measures of standing body sway, with or without visual cues, (Variables 1, 2, 3, and 4.) Somewhat smaller loadings are found for the measures of sitting body sway, and while the measures of sitting body sway have high communalities, their variance is associated with a separate factor (Factor II) to a great extent. Factor I, then, might tentatively be identified as associated with control of standing body sway.

Factor II. This factor includes the tests of body sway while seated, with or without visual cues, (Variables 5, 6, 7, and 8.) It is interesting to note that the two variables having the highest loadings in this factor are the ones concerned with the forward-backward components. The right-left components of sitting body sway emerge with substantial loadings on Factor III. Why only the right-left measures should have their variance so divided is not immediately apparent. However, there seems no doubt that Factors I and II are correlated to some extent. Factor II may be identified as control of sitting body sway.

Factor III. This factor has its major loadings in the horizontal and vertical measures of arm-hand steadiness, (Variables 9 and 10.) These vari-

ables were included in the present battery because they seemed to identify most clearly a factor of involuntary movements in a previous battery.<sup>10</sup> That they are relatively "pure" measures would tend to be confirmed here since the large proportion of their variance is accounted for by this factor. None of the other tests in the current battery have any but incidental loadings in this factor. Factor III may be identified with control of involuntary movements of the arm and hand. This measure is probably the type of thing most commonly associated with the term "steadiness".

Factor IV. This factor is not well defined in the present battery, the only major projection being that of the Straight Tracing Test (Variable 11). Variables 11 and 12 were included in this battery because they seemed the best measures of two factors found in the previous analysis, precision in one plane of slow movement, or several planes, respectively. In the previous study these variables seemed associated with steadiness during movement. Variable 12, as it turns out here, shows very little communality in this battery and one might infer that the spatial component it was hypothesized to measure does not appear in this present battery to any great extent. The fact that what small common factor variance it does have in this battery is associated with tests that have some spatial elements suggests that it is still measuring this factor, however. The minor loadings of variables 2 and 4 in this factor do not seem very meaningful and the significance, if any, of this fact is not immediately apparent. This factor may be considered as steadiness during movement, as in the previous analysis, largely because of the significant loading of variable 11, and the previously isolated factor of precision in multi-plane movement is shown to be largely independent of the newer factors isolated in this study.

Factor V. Factor V has high loadings in the measures associated with

the Balancing Chair (Variables 14, 15, 17, and 18). It is significant, however, that variables 13 and 16 (representing errors made in "Turn" i.e., keeping the chair pointing in the same horizontal direction) do not have any appreciable loadings on this factor. It also seems significant that measures from the Miniature Airplane Test, comparable to those on the chair, do not have appreciable loadings on this factor, but come out as a separate factor (Factor VI). It is with the measures determined from the Miniature Airplane Test that variables 13 and 16 are associated. A reasonable hypothesis would seem to be that this factor V is one which depends upon the static senses, i.e., equilibrium as the key to responses rather than visual cues as the key. Thus, the operation of the airplane was dependent upon primarily visual cues; whereas in the Balancing Chair Test the individual himself moved in space and the cues as to the proper operations to perform in order to maintain the chair in a level position were primarily static, rather than visual. This interpretation is given additional weight when it is noted that the variables which involve no visual cues (17 and 18) also have most of their variance accounted for by this factor. For this reason it seems reasonable to identify this factor as one associated with equilibrium and the static senses.

Factor VI. This factor has highest loadings on the variables derived from the Miniature Airplane Test. It will be recalled that in this test the subject had to maintain an airplane in level "flight" by making proper adjustments of three controls. As suggested above, a reasonable explanation with regard to this test is that it is primarily visual in nature so far as the spatial element is concerned. The fact that variable 13 has its highest loading in this factor would tend to confirm this hypothesis.

As stated above, the structure of the rotated factor loadings matrix suggests some correlation among the various factors. These intercorrelations

can be estimated from graphic plots of the factor loadings by determining the cosine of the angle between the vectors representing the factors. This was done for the factorial matrix of these data and the estimates of the correlations among factors are shown in Table 3.

TABLE 3.

Estimates of the intercorrelations among factors determined from cosines of angles between vectors representing factors.

	1	2	3	4	5	6
1.						
2.	.60					
3.	.41	.56				
4.	.21	-.09	.53			
5.	.19	.00	-.09	.27		
6.	-.22	.09	.09	-.03	.45	

While this matrix suggest appreciable intercorrelations among some of the factors there is still no suggestion that one single underlying factor would explain the obtained factor matrix. It is possible that there are fewer than six factors, and present indications suggest that there are at least three underlying factors which would appear to be relatively independent. The first of these underlying broader group factors is related to the body sway measures; another is one associated with the arm-hand steadiness and tracing tests, and finally a third factor might underly the three-dimensional tests (Balancing Chair and Airplane). A knowledge of both the narrower group factors and the broader underlying factors should be of considerable assistance in selecting tests most promising for further investigation.

### Suggestions for Further Research

From experience with previous factorial analyses of tests emphasizing speed or strength factors it is fairly certain that several subsequent steps, such as the following, are likely to be significant for the advancement of both pure and applied science in the area of psychomotor precision:

1. Redesigning each test having the highest loading on each of six factors isolated in this study so as to provide a portable unit of psychomotor precision tests for experiments in other laboratories and in military ship, air and shore locations. Since the tests were originally designed with portability as an eventual goal, the necessary modifications would be primarily for the purpose of reducing size and weight, and insuring ease of calibration and maintenance outside of laboratories;
2. The Selsyn circuits developed for the three dimensions of movement on the tridimensional Balancing Chair have now been adapted for use as auxiliary equipment on a standard Link Trainer. This would provide a standardized stimulus pattern of movements together with automatic scoring in using the Link Trainer as a selection device as well as in its present function as a trainer. It is the intention of the project director to apply for a follow-up project on both the portable battery and the auxiliary Link Trainer developments in the relatively near future;
3. Testing such a battery of psychomotor precision tests for possible use, in the selection of military and industrial trainees for the operation of complex tools, machines, and weapons calling primarily for precision in slow to medium speed coordinations rather than for high speed or strength;

4. Tests for a number of the principal factors of mechanical abilities isolated by L.L. Thurstone have kindly been supplied by him in order to determine their interrelations with our own battery. Funds for this supplementary experimental work were supplied under a grant from the J. McKeon Cattell Fund of the Psychological Corporation. The experimental and preliminary statistical work on 50 additional subjects has now been completed and are being factorially analyzed by the writers.
5. Using a battery such as our portable psychomotor tests as one set of criteria, for measuring the effect on human efficiency, of various environmental and physiological variables such as changes in temperature, humidity, pressure, air conditioning, drugs, age, motivation, fatigue, and many similar factors. Such uses of the tests are independent of their usefulness as selection devices and have been shown to be significant with other psychomotor tests;
6. Devising batteries of sub-tests differing from each of the present factor tests as to sense modality or cues employed, musculatures involved, and work methods or patterns of action called for, as has been done by Seashore, on speed skills<sup>7</sup>. Such further analysis would permit still more accurate identification of the nature and significance of those variables underlying each present factor, both as to individual differences at the same stage of learning, and the changes within an individual at successive stages of learning;
7. The training of engineers and psychologists in design and construction of psychological instruments could itself be made a project of great importance to both the science of psychology and our military forces. It would be readily possible to set up a training course and practicum facilities to train specialists in instrumentation so as to remove one of the major "bottlenecks" which existed all through World War II and still exists at the present time.

## REFERENCES

1. Forsberg, C. T. The relationship of difficulty of a motor task to computed reliability with special reference to the Spearman-Brown prophecy formula. M. S. dissertation in Psychology, Northwestern University, Evanston, Ill., 1949.
2. Guilford, J. P. Psychometric Methods. McGraw Hill Co., 1936, Ch. XIV.
3. Guilford, J. P. and Lacey, J. I. (Editors) Army Air Forces, Aviation Psychology Program, Research Reports, Apparatus Tests, Classification Tests, Report No. 5, 1947. U. S. Govt. Printing Office, Wash., D. C.
4. McCloy, E. Factor analysis methods in the measurement of motor abilities. Res. Quart. Amer. Phys. Educ. Assn., 1935, 6, 81-85.
5. Melton, A. W. (Editor) Army Air Force, Aviation Psychology Program, Research Reports Apparatus Tests, Report No. 4, 1947, U. S. Govt. Printing Office, Wash., D. C.
6. Seashore, R. H. and Adams, R. D. The measurement of steadiness: a new apparatus and results in marksmanship, Science, 1933, 78, 285-287.
7. Seashore, R. H. Work methods: an often neglected factor underlying individual differences. Psychol. Rev., 1939, 46, 123-141.
8. Seashore, R. H. An experimental and theoretical analysis of fine motor skills. Amer. J. Psychol., 1940, 53, 86-96.
9. Seashore, R. H., Buxton, C. E. and McCollom, I. N. Multiple factorial analysis of fine motor skills, Amer. J. Psychol., 1940, 53, 251-259.
10. Seashore, R. H., Dudek, F. J., and Holtzman, W. A factorial analysis of arm hand precision tests. J. Appl. Psychol., 1949, 33, 579-584.
11. Seashore, R. H. Work and motor performance (Chap. in Steven's and Boring Handbook of Experimental Psychology, Wiley--in press).
12. Zimmerman, W. A simple graphical method for orthogonal rotation of axes, Psychometrika, 1946, 11, 51-55.
13. Zweizig, J. R. Instrumentation in psychomotor testing, Northwestern Engineer, Sept. 1949, 8, p. 9-11 and 34.

Distribution List for Technical Reports Contract N6ori-158, Task Order II,  
(NR 151 132)

	<u>Copies</u>		<u>Copies</u>
Chief of Naval Research Navy Department Washington 25, D. C. (Physiology Branch Code 445)	30	Dr. T. G. Andrews Research & Development Board General Staff, U. S. Army 4D827, Pentagon Building Washington, D. C.	1
Chief of the Bureau of Medicine & Surgery Navy Department Washington 25, D. C.	3	Dr. Arnold Small Naval Electronics Laboratory San Diego, California	1
Commanding Officer Office of Naval Research 844 N. Rush Street Chicago 11, Illinois	1	Dr. Morris S. Viteles University of Pennsylvania Philadelphia, Pennsylvania	1
Commanding Officer Office of Naval Research 495 Summer Street Boston 10, Massachusetts	1	Dr. E. Wight Bakke Institute of Human Relations Yale University 333 Cedar Street New Haven 11, Connecticut	1
Commanding Officer Office of Naval Research Building 9, 10th Floor New York Naval Shipyard Brooklyn 1, New York	1	Dr. Ruth Benedict Department of Anthropology Columbia University New York, New York	1
Commanding Officer Office of Naval Research 1030 E. Green Street Pasadena 1, California	1	Dr. John G. Darley Department of Psychology University of Minnesota Minneapolis, Minnesota	1
Chief of Naval Research Navy Department Washington 25, D. C. (SE Area Contract Administrator Code 269)	1	Dr. Pendleton Herring Carnegie Corporation 522 Fifth Avenue New York 13, New York	1
Office of the Assistant Naval Attache for Research American Embassy Navy 100 c/o Postmaster New York, New York	2	Dr. Dexter Keezer McGraw-Hill Book Company New York, New York	1
Office of the Assistant Naval Attache for Research American Embassy (Med. Representative) Navy 100 c/o Postmaster New York, New York	1	Dr. B. Lowell Kelly Department of Psychology University of Michigan Ann Arbor, Michigan	1
Office of the Assistant Naval Attache for Research American Embassy (Med. Representative) Navy 100 c/o Postmaster New York, New York	1	Mrs. Mary Gushing Niles Federal Personnel Council 1625 K Street, N. W. Washington, D. C.	6

Dr. Alexander Leighton Department of Sociology Cornell University Ithaca, New York	1	Dr. K. E. Clark University of Minnesota Minneapolis, Minnesota	1
Dr. Rensis Likert Survey Research Center University of Michigan Ann Arbor, Michigan	1	Dr. C. N. Cofer University of Maryland College Park, Maryland	1
Dr. George Lombard Graduate School of Business Adm. Harvard University Boston, Massachusetts	1	Dr. D. C. McClelland Psychological Laboratory Wesleyan University Middletown, Connecticut	1
Dr. F. F. Stephan Department of Sociology Princeton University Princeton, New Jersey	1	Dr. John C. Flanagan American Institute for Research Pittsburgh 13, Pennsylvania	1
Dr. Dael Wolfle American Psychological Assoc. 1515 Massachusetts Avenue Washington, D. C.	1	Dr. Albert D. Freiberg Psychological Corporation 522 Fifth Avenue New York 18, New York	1
Dr. L. L. Thurstone Department of Psychology University of Chicago Chicago, Illinois	1	Dr. Henry Odbert Box 871 Hanover, New Hampshire	1
Dr. T. A. Ryan Department of Psychology Cornell University Ithaca, New York	1	ONR, Chicago Branch 844 North Rush Street Chicago 11, Illinois	2
Dr. G. R. Wendt Department of Psychology University of Rochester Rochester, New York	1	Chief of Naval Research Navy Department Washington 25, D. C. Attn: Planning Division	3
Dr. W. A. Hunt Department of Psychology Northwestern University Evanston, Illinois	1	Dr. John P. Flynn Naval Medical Research Center Washington, D. C.	1
Dr. Clements C. Fry Yale University New Haven, Connecticut	1	Dr. Paul E. Klopsteg Director of Research Technological Institute Northwestern University Evanston, Illinois	1
Dr. Neil Warren Univ. of Southern Calif. Los Angeles, California	1	Dr. Leonard C. Mead Department of Psychology Tufts College Medford 55, Massachusetts	1
Dr. H. A. Mitkin Brooklyn College Brooklyn, New York	1	Dr. C. P. Seitz Head, Research Section Human Engineering Branch Special Devices Center Sands Point, Port Washington Long Island, New York	1

William Exton, Jr.  
101 West 57 Street  
New York 19, New York

1 Army Medical Library  
7th & Independence Avenue  
Washington, D. C.

1

The Air University Libraries  
Maxwell Air Force Base, Alabama  
(Requisition No. CR-2535)

1