

VAULT #
9-4360

GM-TR-0165-00583

604507

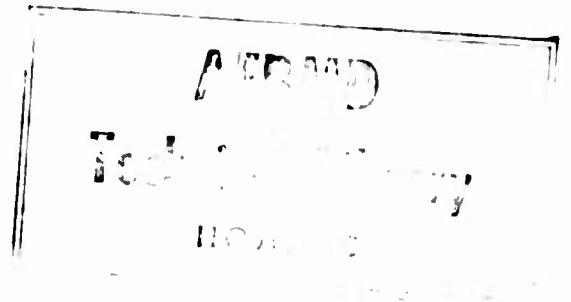

SEMIANNUAL REPORT
ON
PRESSURE VESSEL DESIGN CRITERIA

1 July 1958 to 31 December 1958

Prepared for the Air Force Ballistic Missile Division
Headquarters, Air Research and Development Command
Under Contract AF 04(647)-165

COPY	<u>1</u>	OF	<u>1</u>	<u>copy</u>
HARD COPY				\$. 1.00
MICROFICHE				\$. 0.50

24 p

Prepared by Don Fitzgerald
Donald E. Fitzgerald

Approved M. V. Barton
M. V. Barton

SPACE TECHNOLOGY LABORATORIES, INC
P. O. Box 95001
Los Angeles 45, California

ABSTRACT

The purpose of the work being performed in this program is to provide experimental data to assist in establishing material selection and design and fabrication criteria for reliable, highly efficient pressure vessels. Preliminary values of ductility of 4340 steel ~~have been~~ obtained from fracture strain measurements of narrow-bend and wide-bend specimens, and reductions of useful strength of offset tensile specimens ~~have been~~ measured at several nominal strengths. Correlation of the reduction of wide bend fracture strains with the reduction of useful strength of offset tensile specimens at increasing nominal uniaxial strength levels ~~is~~ indicated. The 4340 steel under consideration ~~has~~ exhibited higher ductility, both in the uniaxial and biaxial stress states, than had been anticipated from previous tests.



CONTENTS

	<u>Page</u>
I. INTRODUCTION	1
II. THEORY AND DESCRIPTION OF TESTS	3
A. Introduction	3
B. Bend Tests	3
C. Tensile Tests	6
D. Pressure Vessel Tests	6
III. RESULTS OF TESTS TO DATE	14
A. Bend Tests	14
B. Tensile Tests	14
C. Pressure Vessel Tests	15
IV. DISCUSSION OF RESULTS	16
V. CONCLUSIONS	18
VI. TECHNICAL PLANS	19
VII. BIBLIOGRAPHY	20

ILLUSTRATIONS

<u>Figure</u>		<u>Page</u>
1 (a) (b)	Narrow Bend Test Specimen	4
2.	Free Bend Test Specimen	5
3 (a) (b)	Wide Bend Test Specimen	7
4.	Tapered Die Press Brake	8
5.	Tensile Test Specimen	9
6.	Pressure Vessel Test Specimen	10
7 (a)	Hardware for Pressure Vessel Test Specimen	12
7 (b)	A Tested Pressure Vessel Specimen	12
8.	Pressure Vessel Testing Apparatus	13

I. INTRODUCTION

The purpose of the work being performed in this program is to provide experimental data to assist in establishing material selection and design and fabrication criteria for reliable, highly efficient pressure vessels. Such vessels are needed for all ballistic missiles, but the need is especially critical in solid-propellant applications such as the Minuteman because the weight of the pressure vessels (engine cases) is a large portion of the missile structural weight. Programs to develop high-strength, high-efficiency pressure vessels have experienced a number of premature failures, some at only a small fraction of the design pressures. The evidence suggests that the failures may be related to the inability of the high-strength material in the biaxial stress state to plastically redistribute local high stresses caused by geometrical discontinuities. This program will provide an evaluation of various materials under these stress conditions and establish the validity of a simple method of material evaluation for pressure-vessel applications.

The effects of local high stresses and stress gradients due to discontinuities typical of manufacturing imperfections are being investigated. Strength, based on material performance in small-scale pressure vessels, will be correlated with biaxial fracture strains observed in tensile and bend tests of simple specimens. The effects of certain discontinuities, surface conditions, and environmental factors will be included. This program will establish the validity of biaxial fracture strain measurements in simple specimens as a material selection criterion and a fabrication quality control inspection technique, and will lead to establishing design and fabrication control criteria for reliable, highly efficient pressure vessels needed for high-performance ballistic missiles and space vehicles.

Approval was obtained on 1 August 1958 to proceed on phases IA, IB, and IIA as outlined in Program Plan 165-13. The work in these phases is limited to 4130 and 4340 steel. Material characteristic uniaxial and biaxial ductility, including the effects of local superimposed high stresses and stress gradients, is being determined in IA by testing simple specimens, and Phase IB will extend the parametric examination of IA. In Phase IIA, the effective strengths of these same materials in small scale pressure-vessel specimens with machined offsets to simulate weld mismatch are being determined. The other three phases

of the program plan, which extend the investigation to other materials and to several environmental conditions, will be implemented, provided that useful correlations can be found among the data of Phases IA, IB, and IIA which will permit material evaluations with respect to pressure-vessel applications from the test results of simple specimens.

The work of Phase IA is being undertaken by Titanium Metals Corporation in Henderson, Nevada, monitored by STL. The starting date of this phase was delayed until about 15 October by late deliveries of special specimen materials. This work includes the testing of narrow bend, wide bend, and offset tensile specimens which are described in the next section.

Phase IB, which was to be undertaken at STL after Phase IA results became available, has not yet started.

The first pressure-vessel tests under Phase IIA are being performed in the Engineering Mechanics Laboratory at STL.

II. THEORY AND DESCRIPTION OF TESTS

A. Introduction

Two types of high-strength steels are under consideration in Phases IA, IB, and IIA of this program. The specimens being investigated are made from 4130 steel heat-treated to a nominal 180-ksi ultimate tensile strength and 4340 steel heat-treated to nominal levels of 180, 220, and 260 ksi ultimate tensile strength. All specimens, excluding the small-scale pressure vessels, were cut from sheet stock both parallel and perpendicular to the rolling direction in order that the directional properties of the material could be evaluated.

In all of the tests to be described, fracture strain measurements were made on each specimen with a measuring microscope from an orthogonal grid pattern which was photographically applied to the specimens prior to the tests. This technique has the distinct advantage of permitting plastic strain determinations to be made over very short gage lengths, 0.01 inch for these specimens. Three types of tests are being conducted.

B. Bend Tests

The bend tests were designed so that the basic ductility of the material in both biaxial and uniaxial stress fields could be determined. When the width of the bend specimen is large compared to its thickness, the stress field resulting from bending is biaxial because of the lateral constraint offered by the excess width. However, as the width of the specimen is reduced, the lateral constraint is reduced and the stress field approaches the uniaxial.

1. Narrow Bend Tests. The critical section of the narrow bend specimen had a width equal to its thickness as shown in Figure 1. The materials in these specimens were subjected to an essentially uniaxial stress field during testing. The specimens were tested in the free bend tester shown in Figure 2. They were placed between the upper and lower anvils and an axial load was applied with the hydraulic ram. Bending was initiated with the pusher which is pivoted on the upper anvil, and was increased by moving the anvils toward each other. Careful inspection of the specimen was made during the test with the aid of the microscope so that bending could be stopped when the first surface fracture was observed. The specimen was then removed and strains were determined adjacent to fracture lines.

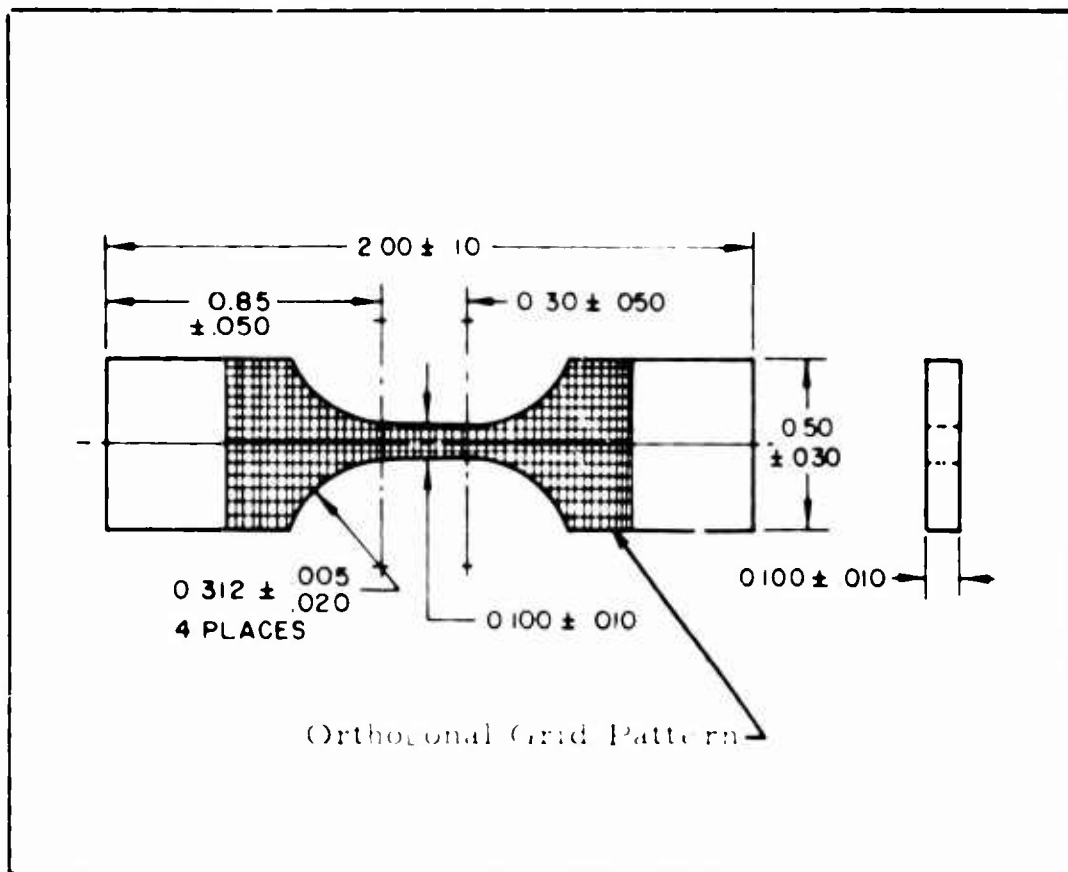

Figure 1a Narrow Bend-Test Specimen Configuration.

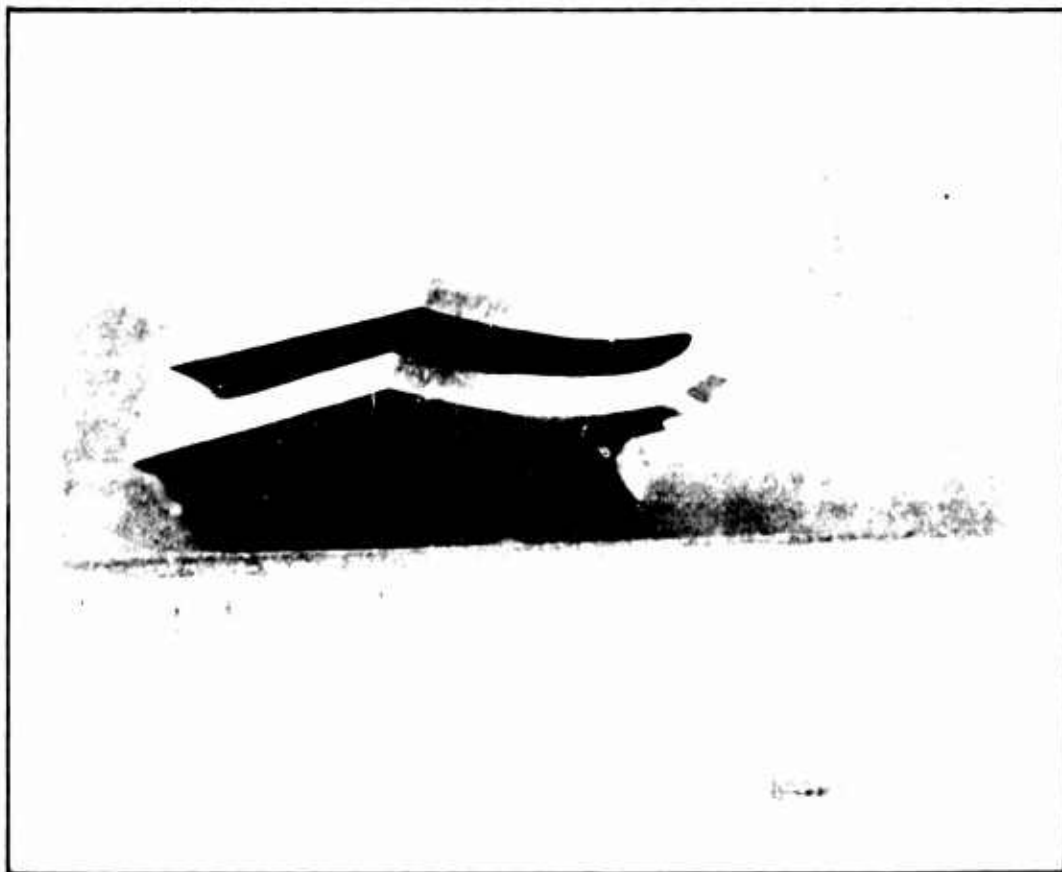

Figure 1b. Narrow Bend-Test Specimen After Test.

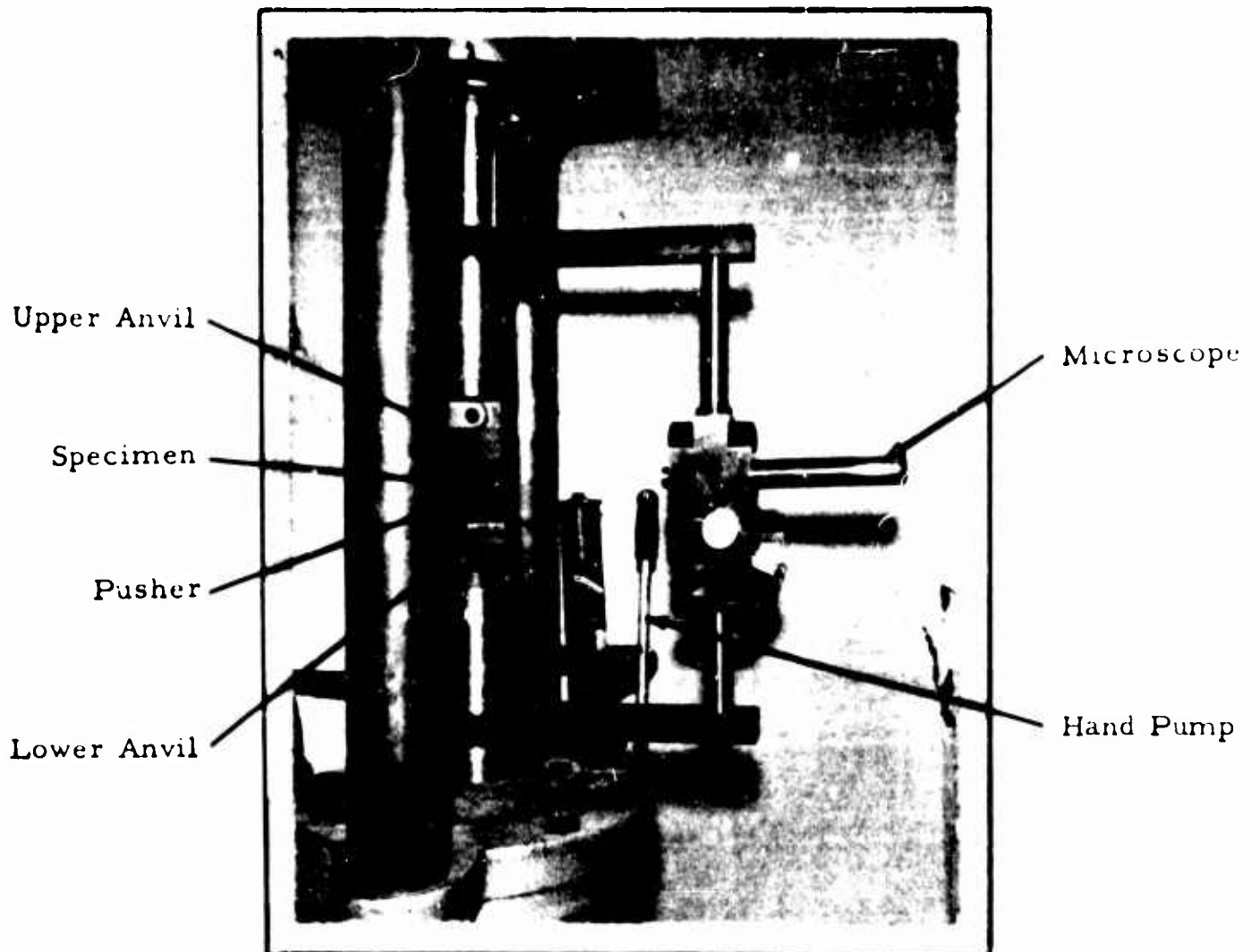

Figure 2. The Free Bend Tester.

2. Wide Bend Tests. The wide bend specimens had a width equal to 10 times the thickness as shown in Figure 3. The material in these specimens was subjected to a biaxial stress. The wide bend specimens were tested in the conically tapered die press brake shown in Figure 4. The conical surface of the die provides a continuously variable radius around which the specimens may be bent. Since the strains in the outside fibers increase with decreasing bend radius, a continuous distribution of strain is developed in each specimen. The specimen is placed in the tapered die at a location which provides the desired range of strains. This location, at which surface fracture lines form without complete specimen failure, is found by trial and error. Upon completion of each test, fracture strain measurements were made.

C. Tensile Tests

The tensile tests were designed to determine the effect of a geometrical discontinuity similar in shape to that of a typical weld mismatch commonly found in pressure vessels. The discontinuity produces a high local bending stress which is superimposed on the basic tensile field. The effective strength of the specimens is a measure of the ability of the material to redistribute plastically these high local stresses without fracture initiation. The actual shape of the specimen's offset is shown in Figure 5. The magnitude of the stress is determined by the offset, overlap length, and fillet radius. Specimens with no offset were tested to obtain the ultimate tensile strength, yield strength, and elongations over 4 inches. The tensile specimens were tested in a 60,000-pound Riehle universal testing machine and fracture strains were measured from photogrids.

D. Pressure Vessel Tests

These vessels were designed with an offset as shown in Figure 6. This offset is a simulated weld mismatch which appears as a circumferential joint on the specimen, but, by applying proper end loads and simultaneous internal pressures to the specimen, the stress conditions typical of a longitudinal joint can be approximated. The inside and outside shoulders on the specimen are for attachment of pressure-sealing end connectors through which the end loads are applied to the specimen. The lower end connector was enlarged to take up most of the internal volume of the specimen in order to minimize the amount of

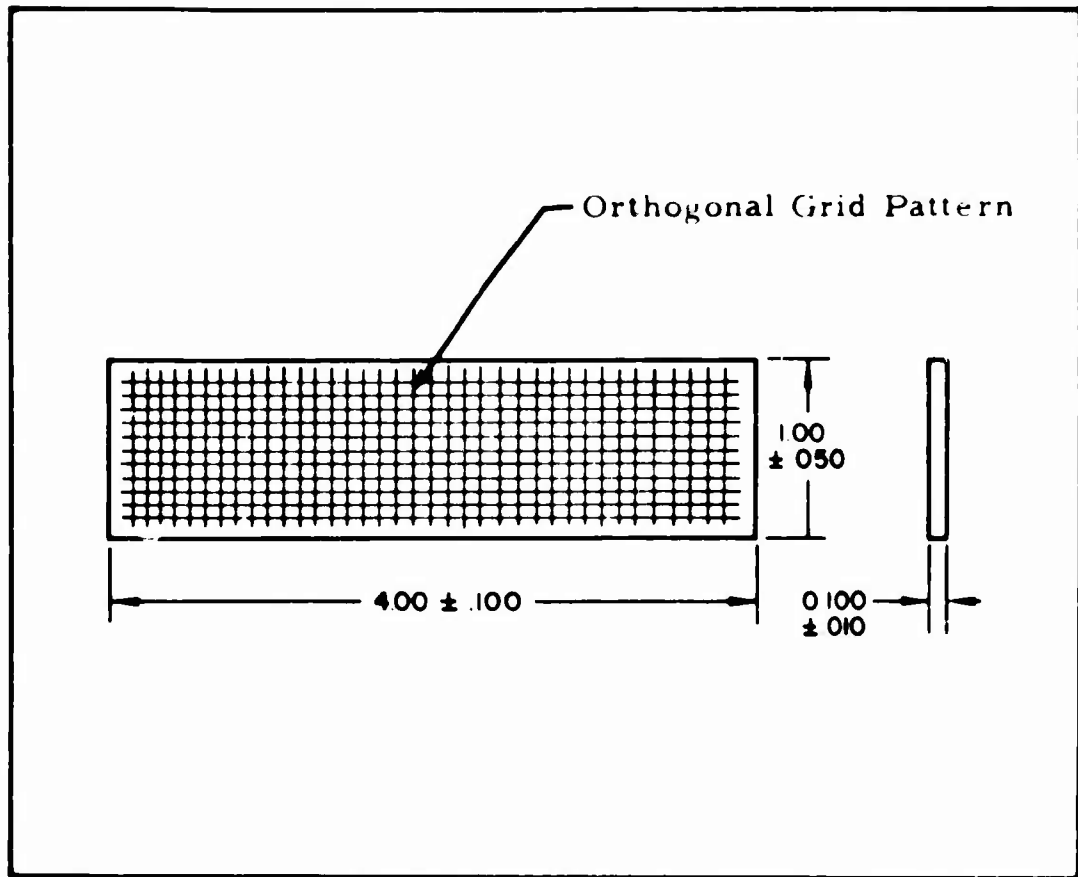

Figure 3a. Wide Bend-Test Specimen Configuration.

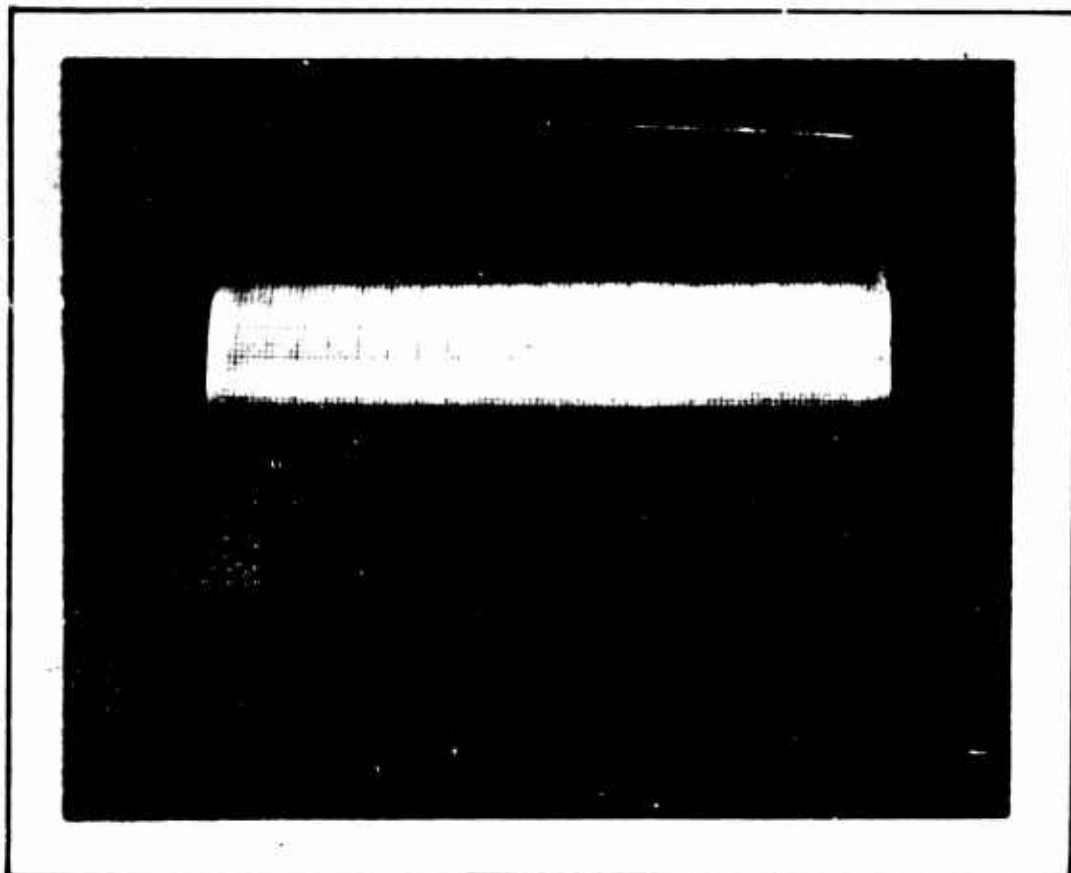

Figure 3b. Wide Bend-Test Specimen After Test.

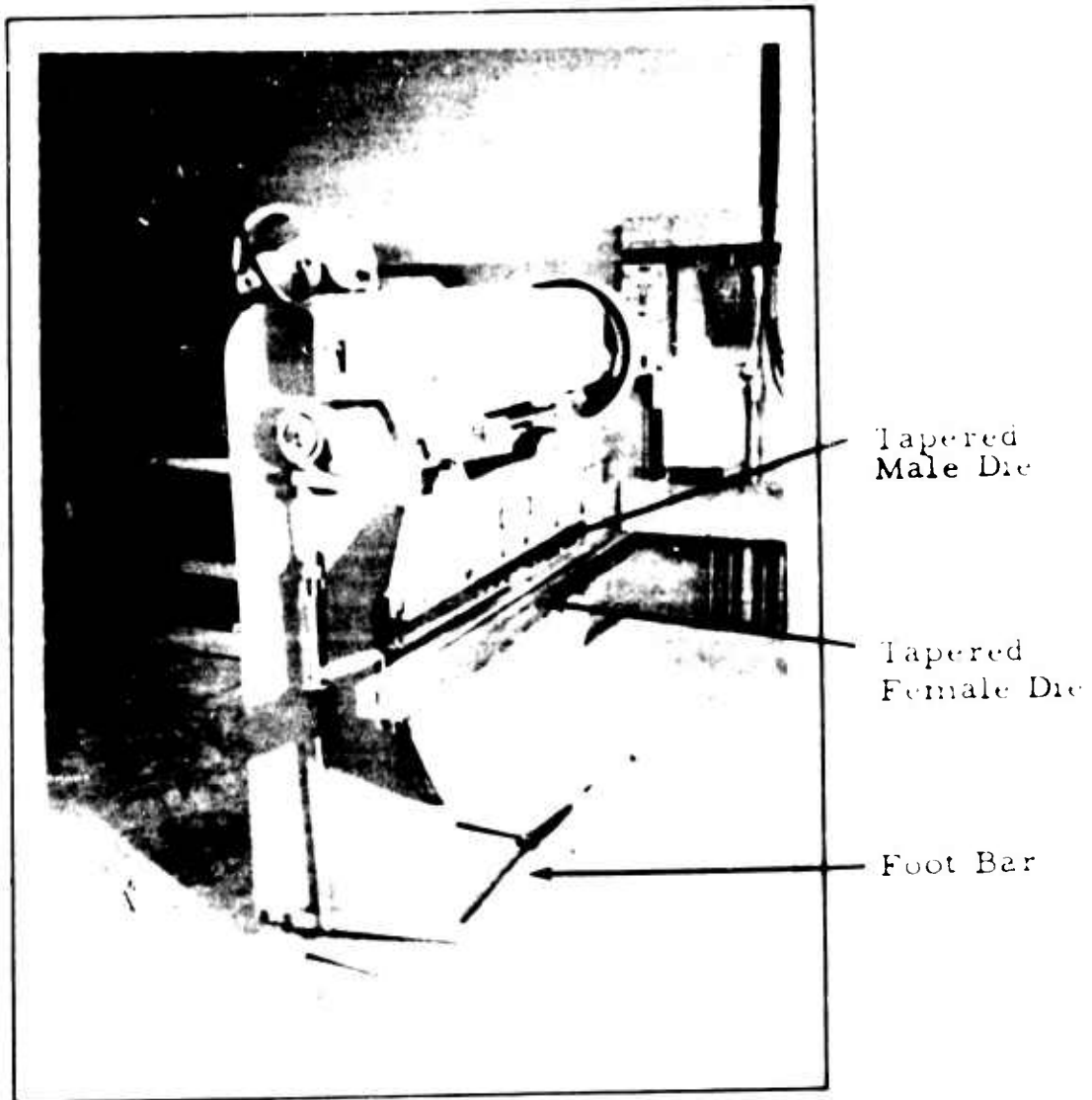

Figure 4. Tapered Dies in the Verson 16-48 Press Brake.

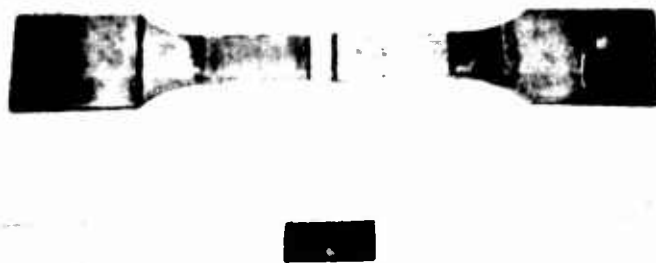
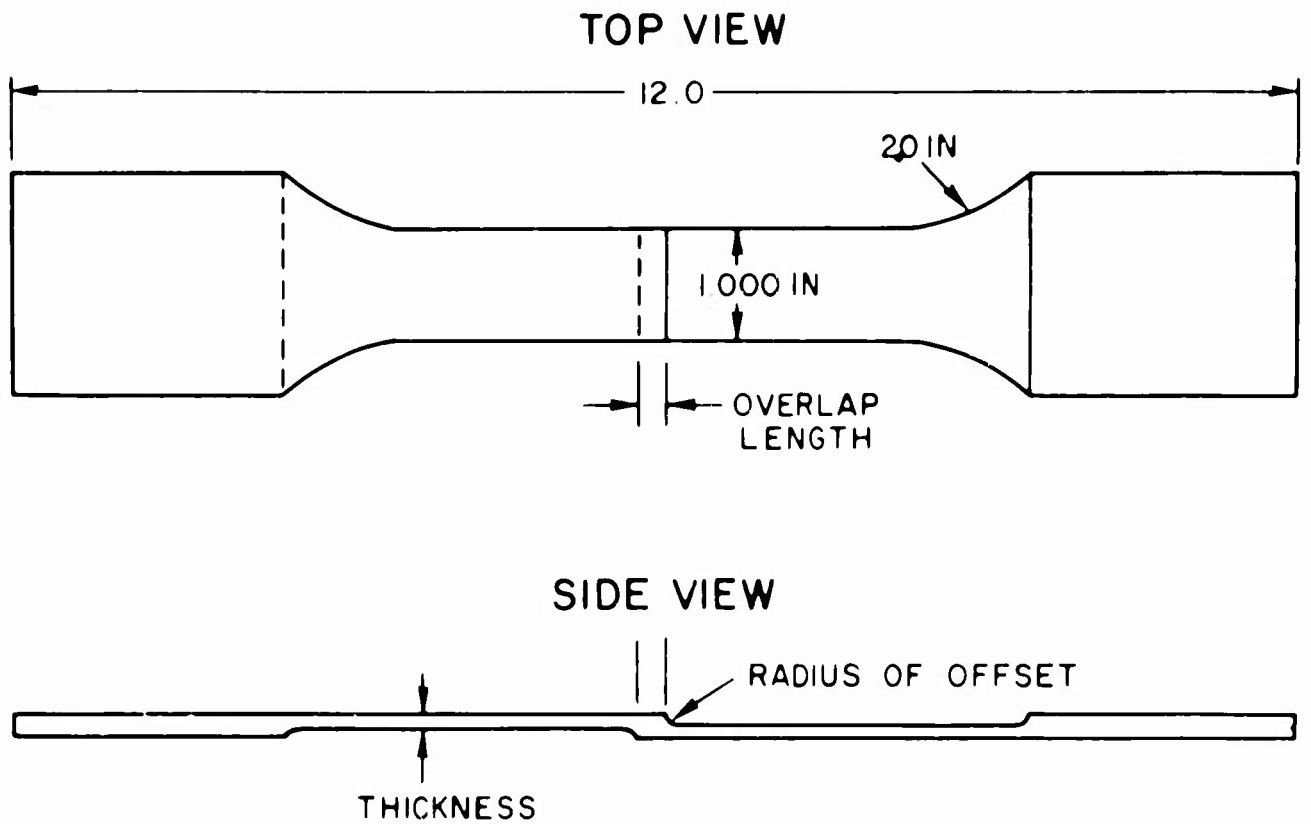

Figure 5. Offset Tensile Test Specimen.

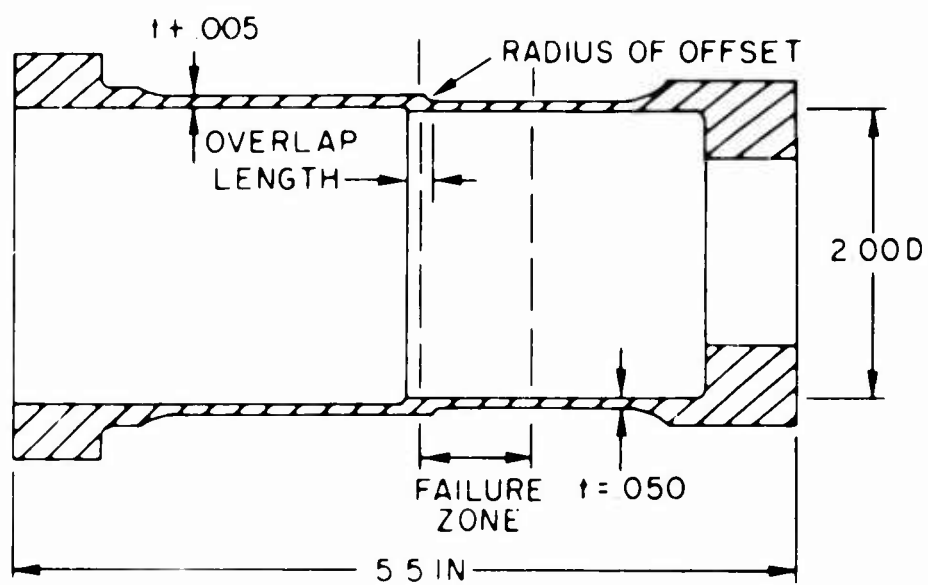

Figure 6. Pressure Vessel Test Specimen.

oil released when fracture occurs. The upper end connector contains access ports for the purpose of admitting oil and for bleeding the system. Figure 7a shows the two end connectors, the pressure vessel, and the protective safety cover which is installed around the specimen prior to burst. The tested specimen is shown in Figure 7b.

The complete experimental setup is shown in Figure 8.

End loads were applied to the specimen through spherical seats in a 120,000-pound Baldwin universal testing machine. An air-driven, high-pressure hydraulic pump was used to pressurize the specimen. Load as a function of pressure was plotted in an x-y plotter throughout loading until fracture. A given ratio of end load to internal pressure was maintained during stressing by increasing the load and adjusting the pressure so that a prescribed path was retraced on the x-y plotter as both of these parameters were increased. The internal pressure and applied end loads acting on the specimen up to and including fracture are presented on the plotter record. Strain measurements were made at discrete points on the specimen during the tests using electric strain gages and the instrumentation shown in Figure 8. Fracture strain measurements were made from photogrids which were photographically applied to the specimen prior to the tests.

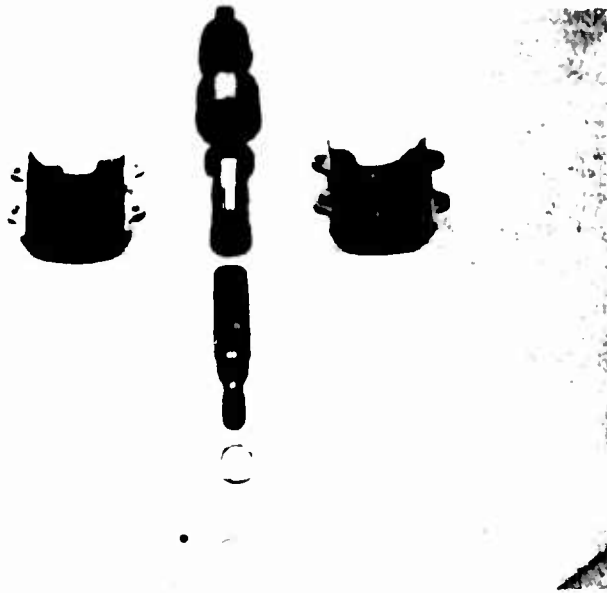

Figure 7a. Hardware for Pressure Vessel Test.

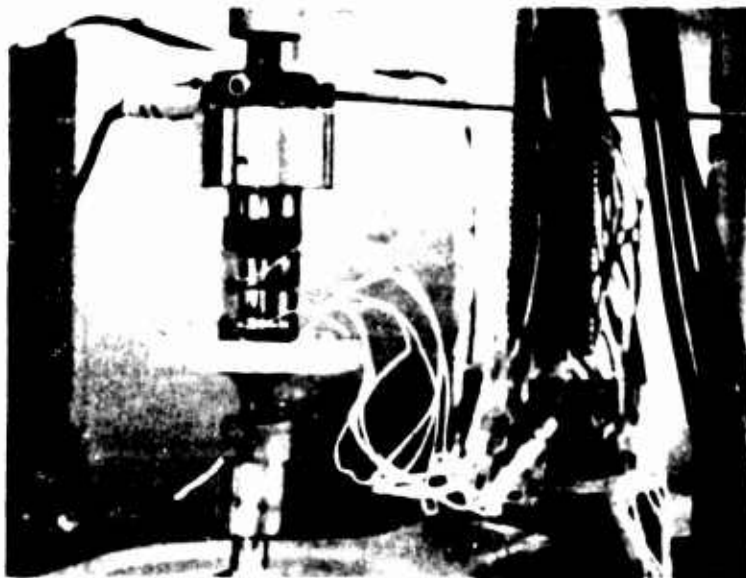

Figure 7b. Tested Pressure Vessel Specimen

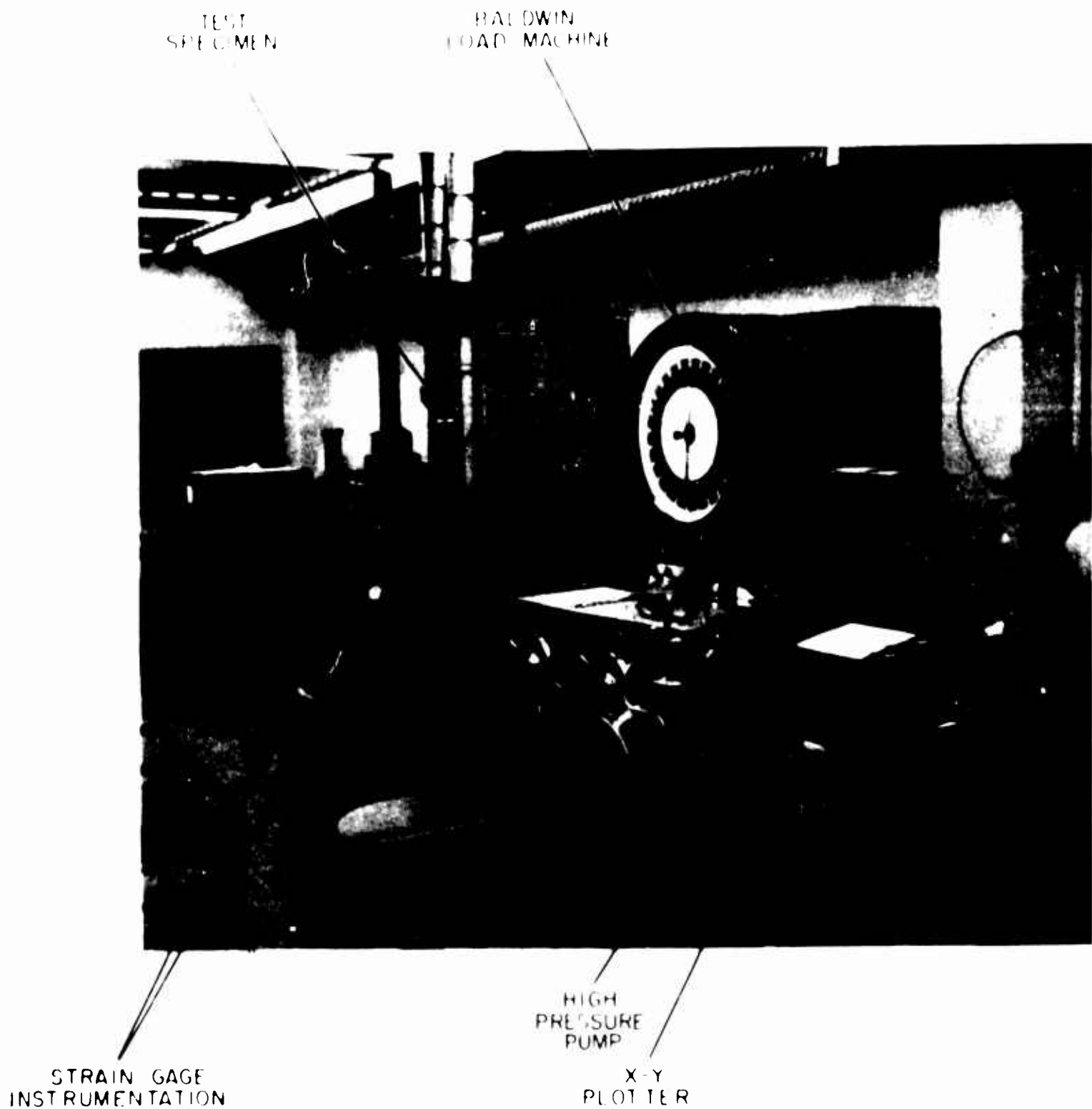

Figure 8 Pressure Vessel Testing Apparatus

III RESULTS OF TESTS TO DATE

A complete qualitative analysis of the material behavior cannot be presented at this time because all of the tests have not been completed, but the trends which have been observed will be discussed. The numbers quoted in the following discussions should be considered somewhat preliminary in nature since statistical scatter is always present in this type of work and since multiple testing to determine the scatter has not been completed in many instances.

A. Bend Tests

In the narrow bend tests, fracture strains as high as 200 per cent have been observed for the 4340 steel heat-treated to the 260-ksi ultimate tensile strength range. For the lower heat-treated levels, many of the specimens were bent double without fracture occurring. Results from the wide bend tests (biaxial stress field) show the expected trend of decreasing fracture strains with increasing degrees of heat-treatment. The fracture strains are in the 40 to 50 per cent range for the 180-ksi level and they drop to the 20 to 30 per cent range for the 260-ksi level. The fracture strains in the essentially uniaxial stress field of the narrow bend specimen were much higher than those in the biaxial stress field of the wide bend specimen. There is some evidence that the strain at which fracture occurs may be dependent upon the surface finish and tests on specimens with smooth and rough grind marks both parallel and perpendicular to the axis of bend are being made.

B. Tensile Tests

In the offset tensile tests, the first specimens tested were made of 4130 steel heat-treated to 180-ksi with 10, 20, and 50 per cent offsets, 0.315-inch fillet radii, and 0.30-inch overlap. All of the specimens failed in a region away from the zone of the offset with no loss in strength based on the tensile load at failure for similar specimens with zero offset. This demonstrated that the material had sufficient ductility to redistribute plastically the stress concentration produced by the offset. Specimens of 4340 steel, heat-treated to the 260-ksi level with 10 per cent offsets, were then tested and they failed in the same ductile manner. Recognizing that the materials had a much higher ductility than was expected, tests were conducted on the most severe case, i.e., the 50 per cent offset and 260-ksi heat-treat level, this specimen also attained full strength.

On account of the unexpected ductility at the high-strength levels, it was necessary to determine the effects of variations in the length of the offset overlap section and the radius of the offset transitions, since these factors also contribute to the magnitude of the local stresses. Some very recent test results on specimens with a 50 per cent offset, a 0.015-inch fillet radius, and nominal heat-treatments of 180, 220, and 260 ksi show reductions in strength of approximately 8, 14, and 35 per cent, respectively.

C. Pressure Vessel Tests

Three preliminary tests have been conducted on small-scale pressure vessels. In each case, the computed bursting stresses were higher than would be predicted for the uniaxial ultimate tensile strength based on Rockwell hardness values. However, the Rockwell readings were taken on the end of the specimen instead of on the cylindrical wall where failure occurred and the walls may have had a higher hardness than the ends of the specimen. It also may be noted that, since the biaxial stress field inhibits necking in the thickness direction, failure may be expected to occur at higher nominal stress levels than in uniaxial tensile tests.

One of the tested specimens with a 50 per cent offset and heat-treated to the 220-ksi level was internally pressurized and end-loaded so that the axial stress was twice the circumferential stress. As in many of the offset tensile tests, the specimen failed in a region away from the offset, indicating that the material had sufficient ductility to redistribute plastically the high local biaxial stresses in the offset region.

IV. DISCUSSION OF RESULTS

The material under consideration has exhibited uniaxial tensile properties (ultimate strength vs. Rockwell hardness, yield point vs. ultimate and elongation in 4-inch gage length) which agree with published values. However, fracture strains from wide and narrow bend specimens are much higher than those obtained on similar specimens prior to the initiation of this program. These previously measured fracture strains were measured on bend and tensile specimens fabricated from an undamaged portion of a developmental solid-propellant case which had failed at a very small fraction of the design pressure. The uniaxial tensile properties of the case material also agreed with published values but the limiting strains before fracture in bend tests were much lower than those which are now being measured from specimens made of the same type of material at the same nominal heat-treat level of 260 ksi as shown below.

	<u>Narrow Bend Fracture Strains</u>	<u>Wide Bend Fracture Strains</u>
4340 steel from solid-propellant case	30-35%	4-7%
4340 steel in present tests	150-200%	20-30%

The exact reasons for these large differences cannot be determined from present data but they may result from different surface conditions for the two specimens and even from differences in the basic metallurgical structure in the two materials which could result from different fabrication and heat-treatment practices.

One surface condition different in the two tests was the initial stress state at the surface before test. For both tests, specimen material was removed by grinding to produce the desired net thicknesses. But specimens from the propellant case were ground after heat treatment while the specimens presently being tested were ground before heat treatment. Grinding produces residual surface tensions which would be eliminated by subsequent heat-treatment. Therefore, surface fractures in the stress-relieved specimens would appear at higher measured fracture strains. A second surface condition which may have made a difference is surface smoothness. Some results to date indicate that the measured fracture strains on bend specimens are dependent upon this factor. The magnitude of this effect cannot be determined from existing data.

The observed decreases in nominal strengths of the offset tensile specimens and decreases in measured fracture strains of the wide bend specimens both with increasing levels of heat-treatment tend to affirm that there is a correlation between these two measurements. However, because of the limited data, relatively large scatter and the presently unknown effects of other factors such as surface conditions, the quantitative correlation cannot be determined at this time.

Fracture strains in both the tensile and pressure vessel specimens were highly localized. In most instances, the strain readings from the first two grid lines adjacent to the fractures were of about the same magnitude as the uniform elongations elsewhere on the specimen. However, by making measurements across a fracture and subtracting the width of the fracture, strains in the order of those obtained from the wide bend tests were determined. This indicates that the fracture elongations have a very high gradient and are concentrated in lengths less than the distance between grid lines which were initially 0.01 inch apart.

V. CONCLUSIONS

1. Based on the limited data obtained so far, it appears that there is indeed a positive correlation between the reduction of wide bend (biaxial) fracture strains with increasing heat-treatment level, and the reduction of effective strength of offset tensile specimens with increasing heat-treatment level. The quantitative correlation may be strongly influenced by certain factors not yet evaluated, such as surface conditions and metallurgical differences.

2. Since the fracture strains measured so far appear to be strongly related to specimen conditions, such as residual stresses and smoothness, it may develop that fracture strain may not be truly definable as an inherent material property at any given uniaxial strength level. Whether this contingency should affect the usefulness of the concept has yet to be determined.

3. The high biaxial ductility that homogeneous 4340 steel has demonstrated in tests to date makes it clear that the effects of metallurgical discontinuities, such as those near welds (which include reduction of biaxial ductility in these regions) and the interactions of these discontinuities with the geometrical discontinuities (causing local stress concentrations) may be of even greater importance in limiting the useful strength of pressure vessels than basic parent metal biaxial ductility.

VI. TECHNICAL PLANS

1. Wide bend tests will be completed so that the effects of surface conditions on fracture strains can be determined. Multiple testing to define the statistical scatter in these data will be continued.

2. The range of parameters such as overlap length, fillet radius, percentage of offset, and degree of heat-treatment, which are detrimental to the strength of the offset tensile specimen, will be determined. Once the critical values of these parameters are determined, the small-scale pressure vessel tests will be resumed, incorporating these critical values.

3. Efforts will be made to correlate the fracture strain measurements from the wide bend specimens with the bursting strength of the small-scale pressure vessels for 4340 steel at various strength levels.

VII. BIBLIOGRAPHY

- GM 13 3-2532 Program Plan 165-13, Pressure Vessel Design Criteria Development, 1 June 1958, Planned for Performance Under Contract AF 04(647)-165. Space Technology Laboratories, Inc.
- GM 61.0-205 Quarterly Status Report on Pressure Vessel Design Criteria, 1 July 1958 - 30 September 1958, Space Technology Laboratories, Inc.
- GM 598021.5-2 Quarterly Status Report on Pressure Vessel Design Criteria, 1 October - 30 December 1958, Space Technology Laboratories, Inc.