



When government drawings, specifications, or other data are used for any purpose other than in connection with a definitely related Government procurement operation, the United States Government thereby incurs no responsibility nor any obligation whatsoever and the fact that the Government may have formulated, furnished, or in any way supplied the said drawings, specifications, or other data is not to be regarded by implication or otherwise as conveying any rights or permission, to manufacture, use, or sell any patented invention that may in any way be related thereto.

The findings in this report are not to be construed as an official Department of the Army position.

DELCO-REMY DIVISION  
OF  
GENERAL MOTORS CORPORATION

FINAL REPORT PART II

FEASIBILITY STUDIES OF THE ELECTROTHERMALLY  
REGENERATIVE TRANSDUCER

Written by:

Robert D. Weaver

Approved by:

John J. Lander

30 June 1964

PERFORMED UNDER THE TECHNICAL SUPERVISION OF RESEARCH  
AND ENGINEERING DIRECTORATE ARMY TANK AND AUTOMOTIVE CENTER

CONTRACT DA 33-008-ORD-2335 (T)

CINCINNATI ORDNANCE DISTRICT

ORDNANCE MANAGEMENT STRUCTURE CODE NO. 5521.12.27540.31

DEPARTMENT OF THE ARMY PROJECT NO. 518-01-001

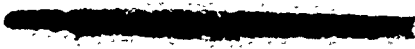

ABSTRACT

Laboratory cells, utilizing sodium and chlorine as reactants, have been assembled and tested. They were shown to produce theoretical voltages over a temperature range of 825°C to 1219°C and were capable of being discharged at more than 20 amperes per square inch of electrode area. They were charged and discharged and exhibited electrochemical reversibility. Studies of protective coatings for cell container materials were made. A cell of more advanced design leading toward a prototype cell was engineered and assembled and tested. This work is evaluated in terms of practical feasibility of the Electrothermally Regenerative Transducer and a fuel cell battery based on the alkali metals and the halogens as reactants. Recommendations for future work are made.

Signed:

Robert D. Weiser

Approved:

JJ Lander

TABLE OF CONTENTS

	Page
ABSTRACT	
TABLE OF CONTENTS . . . . .	ii
LIST OF FIGURES . . . . .	iii
LIST OF TABLES . . . . .	iv
INTRODUCTION, PART I . . . . .	1
INTRODUCTION, PART II . . . . .	5
OBJECT . . . . .	7
SUMMARY . . . . .	8
CONCLUSIONS . . . . .	9
RECOMMENDATIONS . . . . .	12
DATA . . . . .	15
<u>Cell Case Materials</u> . . . . .	15
<u>Case Materials, Protective Coatings</u> . . . . .	18
<u>Materials, Bonding Techniques</u> . . . . .	37
<u>Electrode and Laboratory Cell Studies</u> . . . . .	43
Sodium Chlorine Cells . . . . .	44
Other Alkali-Metal Halogen Cells . . . . .	56
Voltage Change with Temperature . . . . .	59
CELL STUDIES (PARALLEL, CLOSE-SPACED PLATES). . . . .	70
<u>Designs</u> . . . . .	70
<u>Pressure-Seal Cell Runs</u> . . . . .	82
REFERENCES CITED . . . . .	85
ABSTRACT CARDS	
TECHNICAL REPORT DISTRIBUTION	

LIST OF FIGURES

Nr.	Title	Page
1	Photograph of Ceramic-Coated Tungsten Disk as Received . . .	22
2	Photograph of Ceramic-Coated Tungsten Disk After Heat Treatment at 800°C. . . . .	23
3	Photograph of Ceramic-Coated Disks After Exposure to Cl <sub>2</sub> at 800°C. . . . .	24
4	Photograph of Ceramic-Coated Dumbell . . . . .	25
5	Photograph of Dumbell After Exposure to Helium at 825°C. Top View . . . . .	27
6	Photograph of Dumbell After Exposure to Helium at 825°C. Bottom View . . . . .	28
7	Photograph of Dumbell After Exposure to Cl <sub>2</sub> at 825°C. Top View . . . . .	29
8	Photograph of Dumbell After Exposure to Cl <sub>2</sub> at 825°C. Bottom View . . . . .	30
9	Section of Dumbell After Treatment . . . . .	31
10	Photomicrograph of Dumbell-Glaze Interface . . . . .	33
11	Photomicrograph of Dumbell-Glaze Interface Polarized Light .	34
12	Photomicrograph of Dumbell-Glaze Interface Polarized Light, Chemical Etch . . . . .	35
13	Photograph of Ceramic-Coated Bar . . . . .	36
14	Photograph of Ceramic-Coated Bar After Exposure to Cl <sub>2</sub> at 825°C. . . . .	38
15	Photograph of Parts Employed in Bonding and Expansion Studies . . . . .	40
16	Drawing of Alumina "U" Cell . . . . .	45
17	Drawing of Sodium Electrode Assembly . . . . .	47
18	Photograph of "U" Cell Components . . . . .	48
19	Photograph of "U" Cell Assembly . . . . .	51
20	Variation of Na   Cl <sub>2</sub> Cell Voltage with Current . . . . .	55
21	Photograph of Alumina "U" Cell Showing Failure Points . . .	61

LIST OF FIGURES (CONTINUED)

Nr.	Title	Page
22	Photograph of $\Delta E/\Delta T$ Cell Prior to Addition of NaCl . . . . .	63
23	Photograph of $\Delta E/\Delta T$ Cell with Chlorine Electrode . . . . .	64
24	Plot of Cell Voltage Against Temperature . . . . .	67
25	Cross Section of Welded Cell . . . . .	71
26	Cross Section of Pressure-Seal Cell . . . . .	73
27	Photograph of Pressure-Seal Vice . . . . .	75
28	Photograph of Pressure-Seal Cell Components . . . . .	76
29	Photograph of Sodium Electrode for Pressure-Seal Cell . . . . .	77
30	Experimental Set-Up of Pressure-Seal Cell . . . . .	81

LIST OF TABLES

Nr.	Title	Page
1	Results of Corrosion Tests . . . . .	17
2	Coefficient of Expansion Data . . . . .	42
3	Sodium Electrode Materials . . . . .	49
4	Record of "U" Cell Runs . . . . .	52
5	Utilization Efficiency of Grid Materials . . . . .	57
6	Cell Voltage Versus Temperature Data . . . . .	66
7	Design of Coefficient Adjustments for Cell . . . . .	80

## INTRODUCTION

### PART I

On 30 May 1962, research contract DA 33-008-ORD-2335 was awarded to Delco-Remy Division, General Motors Corporation, by the Cincinnati Ordnance District, U. S. Army, with the Army Ordnance Tank Center as contract monitor. This contract, providing for an initial evaluation of a new convertor which has been named the Electrothermally Regenerative Transducer, came as a result of a study by Delco-Remy of the many various methods currently being considered as possible means to convert thermal energy to electricity. During this study, it was recognized that little work was being done with electrochemical approaches to the problem; the principal electrochemical area being studied was that of thermal regeneration of compounds in electrochemical systems which are commonly referred to as thermally regenerative fuel cells. It was also recognized that those electrochemical systems employing compounds which provide for high energy, high voltage, and high reaction rates, all properties which are desirable in a practical device, can be shown to be thermodynamically unsuited to thermal regeneration because higher-than-practical temperatures are required to effect thermal decomposition. Thus it was that the concept of electrothermal regeneration came to be, for this concept embodies the desirable properties just described, while allowing operation at temperatures not considered to be unattainable.

An initial evaluation of the concept of electrothermal transducer, as studied for an application as a power source for satellite vehicles, yielded results that promised a competitive position with the other systems being studied. Because of this potential capability for transforming heat to electricity, in a manner competitive on the basis of efficiency, specific power ratings and reliability, and because of the current and future need of ATAC for such transducing systems, this contract was awarded. The purpose of the contract was to continue the evaluation of the electrothermally regenerative transducer, and to orient the evaluation to the needs of ATAC.

In this, the final report of that contract, will be presented the results of that investigation, as performed with laboratory research and with

system studies. Although the description of the concept and the need for the studies called for in the contract were described in reports prepared prior to the contract award date, in order to save the reader's time in locating and reading these prior communications, and to preserve the continuity of the material presented in body of the text, a brief description of the concept of electrothermally regenerative transducers, and the areas of research necessary to the proof of principle, will be included in this introduction.

As already stated, the class of reactants chosen for this transducing system is that to which high cell voltages and excellent current-density behavior are to be expected. As an example of such a system, consider a battery, or cell, in which the anodic fuel is metallic sodium and the cathodic fuel is chlorine. Both of these reactants are known to possess kinetic characteristics which would promise that current densities would be many times those usually encountered in conventional batteries. Such a cell would provide approximately 4 volts as the open-circuit potential at room temperature. Systems such as these are of interest to this study.

If we further consider this sodium|chlorine cell, it will be recognized that the product of the electrochemical reaction is sodium chloride, which is a solid at room temperature. If the usual techniques were employed in this cell, an electrolyte, compatible with both sodium and chlorine, would be chosen, and the sodium chloride that would be formed, as current was drawn, would increase in concentration in the vicinity of the electrode. This build-up of reaction product would cause a decrease in cell voltage and a decrease in available current density, and is called concentration polarization. Concentration polarization is largely responsible for the limited performance of batteries.

If, on the other hand, the electrolyte chosen were sodium chloride itself, then no concentration polarization would be expected, for the product would not increase the concentration of the electrolyte. If this electrolyte were employed, the conductivity for the cell would be increased by a factor of four or more as compared with conventional systems. This would result in less than one-fourth as much loss in voltage for any given current density. In order to obtain such performance, it would be necessary to operate the

cell at a temperature above the melting point of the electrolyte, in this case, about 800°C (1475°F). At this temperature, the voltage of the cell would still be above 3 volts.

A cell has thus been described which affords the characteristics of low voltage losses at high current densities and high cell voltage. A battery of such cells will be referred to in subsequent pages as a Cold-Cell battery. If such a cell were produced, it would excel in performance over all other cells currently available today. But, such a cell will not transform heat to electricity. If, however, the product, sodium chloride, were raised to a sufficiently high temperature, the voltage of the cell would vanish, and the sodium chloride would decompose into sodium and chlorine which could then be separated, cooled, and used again in the cell to produce electrical power. However, the temperature at which this occurs to an appreciable extent is about 4000°C (7200°F) which is not a practical temperature. Thus, if it were desired to operate such a thermally regenerative cell, it would be necessary to employ less energetic reactants to enable regeneration at lower temperatures. This is the approach that has been taken with thermally regenerative systems now being investigated, and this lower temperature of operation has resulted in system voltages which are usually less than 0.5 volts.

Thus, if we wish to retain the advantages of reactant systems which require dissociation temperatures which are higher than practical, we must develop some method different from thermal regeneration. To do this, as is done with electrothermal regeneration, advantage is taken of the fact that the cell voltage decreases with increasing temperature. In the example of the sodium chlorine cell, it was stated that the cell voltage decreases from a voltage of 4 volts at room temperature to a voltage of more than 3 volts at 800°C, the temperature at which sodium chloride melts. This trend continues, and at the higher temperature of 1500°C, the temperature at which sodium chloride boils, the cell voltage is decreased to about 2 volts. These facts provide the basis for electrothermal regeneration.

The conversion of heat to electricity using this principle is accomplished by the simple combination of two sodium chlorine cells whose temperatures of operation differ. These cells are electrically connected so that the 3 volts of the cold cell are employed to electrically charge the hot cell

whose voltage is 2 volts. Since one cell is being charged and the other is being discharged at the same time, no net change in quantities of reactants occurs. Exactly as much sodium and chlorine are consumed in the cold cell as are produced in the hot cell; thus, no chemicals are consumed, and only heat energy is employed in producing electricity. The net difference in voltage, approximately 1 volt, is available to do work in an external electrical load. This energy is available as a result of the transfer of heat through the temperature gradient associated with the hot and the cold cells of the transducer. The efficiency of conversion is limited to Carnot efficiencies. This approach provides for a new electrochemical convertor of heat to electricity.

The prospect of transforming heat to electrical energy, in a silent and efficient manner with a transducer that can operate from a chemical flame, is of potential advantage to the present and expected needs of ATAC. If a transducer were installed in a tank vehicle to supply starting and auxiliary electrical power, significant savings in engine wear and fuel consumption might be realized, for it would no longer be necessary to idle the engine when only electrical power were needed. The tasks chosen for evaluation for this contract are based upon these possible advantages. Chosen for initial evaluation were the study of the replacement of the generator, voltage regulator, and batteries of a tank vehicle, and the study of the expected characteristics of a transducer to supply sufficient electrical power for vehicular propulsion. These problems are those which are considered in the System Studies section which follows. The evaluation of the application of the Electrothermally Regenerative Transducer, as presented in that section, is made on the basis of calculated weights, sizes and efficiencies.

Because no electrochemical device has been operated at the temperatures and conditions contemplated for this transducer, it was necessary to conduct a laboratory research investigation of representative electrodes which are operated under those conditions. Such experimentation would thus justify the fundamental assumptions associated with the concept. The results of these studies are presented in the Laboratory Studies section of the text.

INTRODUCTION  
PART II

The results of the studies performed under Part I of this program showed the theoretical basis for Electrothermal Transducers and "Cold-Cell" batteries to be sound. Experimental substantiation of the concepts was needed, however, if the feasibility evaluation were to be put on a more practical basis, especially because the concepts involve utilization of such extremely reactive and corrosive chemicals as the alkali metals and the halogens, as well as the fused salts, at high temperatures.

During the work of Part I, studies of chlorine single electrodes had been made with excellent results, but these had not been examined for behavior in a complete cell. On the other hand, the sodium electrode had scarcely been touched experimentally even as a single electrode; information about electrode materials, porosity, and electrochemical behavior was lacking. Data from complete cells, made with materials which could provide a suitable test bed for the accumulation of electrochemical data, were needed.

Given an adequate cell, the following data were considered necessary to enable evaluation of feasibility on a more practical basis:

- one, open-circuit values of cell voltage as a function of temperature - to provide a check on theoretical values and to describe the limiting useful voltage obtainable from the electrothermally regenerative transducer system;
- two, values of cell voltage as a function of electrode current density both on charge and discharge - to provide information basic to design and to allow practical estimates to be made of attainable energy densities, either for the transducer or the "Cold-Cell" battery;
- three, measurements of Faradaic efficiency on discharge - to further define the problem of solubility of the alkali metal in the electrolyte, and the extent to which this might affect evaluation of feasibility of both the "Cold-Cell" battery and the transducer;

four, estimation of internal electronic short-circuits, or lack thereof - also, to determine possible effects on operational efficiencies.

The experimental work done in obtaining data in the several problem areas is described in this report.

It is pointed out that the emphasis in this work was placed on the construction and test of cells based on the low-temperature portion of the total transducer system. This approach was taken due to limitations of time and funds and because study of the "Cold-Cell" portion would, by itself, produce data potentially useful in a fuel-cell type battery.

OBJECT

The objectives of this second year's work under the contract were to provide additional demonstration of the validity of the principles of the Electrothermal Transducer concept and to provide information leading to design and performance evaluation of "Cold-Cell" batteries on a unit cell basis. A "Cold Cell" is defined as the low-temperature half of a total transducer in which alkali metals and halogens could be used as the active materials in a molten salt electrolyte fuel cell.

## SUMMARY

Complete "Cold Cells" based on the use of sodium as the alkali metal and chlorine as the halogen were operated in a "U-tube" cell with sodium chloride as the molten salt electrolyte.

Successful operation of the simple "U-tube" design was enabled by: one, fabrication of high purity aluminum oxide cell cases in the "U" configuration; two, provision of a satisfactory porous metal sodium electrode; three, the use of techniques to exclude oxygen and water vapor from the reactants and electrolyte of an operating cell and the development of the necessary high temperature techniques. Additionally, new information on the carbon materials for the chlorine electrode was obtained.

The change in open-cell voltage was measured over the range 82°C to 1219°C and was found to decrease from 3.24 volts to 2.55 volts, in agreement with theory.

Cells were charged and discharged at temperatures both below and above that for the boiling point of sodium at several current densities. Discharge currents above 20 amperes per square inch were attained at 82°C. Electrochemically reversible behavior was observed. Faradaic efficiencies were measured. The data are believed to allow interpretation in terms of electronic short-circuiting through the electrolyte.

Additional problems which might arise from more sophistication in design were considered. Corrosion measurements on various metals and protective coatings exposed to chlorine gas at cell operating temperatures were made. A laboratory prototype design involving parallel electrodes and a thin electrolyte gap was generated, fabricated, and tested at temperature in preparation for obtaining electrochemical data. Preliminary results from two test runs were obtained.

The data obtained are evaluated in terms of feasibility of ultimate attainment of practical transducers and in terms of the "Cold-Cell" battery portion of the total system.

## CONCLUSIONS

This phase of the study of feasibility of the Electrothermal Transducer and "Cold-Cell" batteries based on the alkali metals and the halogens as reactants yields the following general conclusions. First, practical feasibility of operational transducers would need considerably more work to enable demonstration, if "practical" feasibility is defined as a working laboratory model. The possibility of achievement of such a device is enhanced by this work to an extent explained below. Second, the practical feasibility of operational "Cold-Cell" batteries with very high energy density yields is considerably enhanced by the work described herein, even under the above definition of practical feasibility.

Conclusions drawn which bear directly on transducer feasibility are:

- one, the voltage of a transducer which might be based on the principles elaborated in the Introduction, Part I, would have an open-circuit voltage of 0.79 volts for a  $392^{\circ}\text{C}$  temperature difference. Therefore, theoretical calculations of transducer voltage made in Part I, which predicted 1 volt for a  $700^{\circ}\text{C}$  temperature difference, have been experimentally substantiated;
- two, cells have been successfully recharged at temperatures as high as  $1057^{\circ}\text{C}$ ; it seems probable that recharge capability will be possible at higher temperatures; therefore, electrochemical reaction required at the "Hot Cell" of a transducer has been experimentally demonstrated to some extent;
- three, the electrode materials used withstood temperatures as high as  $1219^{\circ}\text{C}$  for the times involved without obvious degradation, therefore the electrode materials problems have been partially solved.

Conclusions drawn which bear directly on "Cold-Cell" performance but which may reflect on transducer feasibility are these:

- one, the open-circuit voltage value of the sodium | chlorine cell at  $825^{\circ}\text{C}$  was measured to be 3.2 volts, in agreement with theory

- therefore fewer cells would be necessary to make up a battery pack of any given voltage than would be necessary for other types of fuel cells currently under investigation;
- two, current densities attainable in sodium | chlorine cells are in excess of 20 amperes per square inch and behavior of both electrodes is electrochemically reversible; therefore, the performance of such batteries is likely to be limited by the electrolyte resistance;
- three, electrolyte resistances of fused salt electrolytes are considerably lower than those used for conventional battery systems and fuel cells;
- four, the combination of the above three experimentally demonstrated performance factors will allow very high energy density cells and batteries to become operational, if they can be successfully engineered;
- five, the electrodes used are easily fabricated in the laboratory to yield the performances quoted; therefore, successful production techniques are likely; furthermore, scale-up problems may be reduced due to the high current density capability which should result in considerably reduced electrode area in comparison to other cell types;
- six, the Faradaic efficiencies measured are too low to be acceptable and the inefficiency arises from a fundamental chemical cause, therefore means of obtaining much-improved efficiencies are needed. Some inefficiency could be allowed in the operation of "Cold-Cell" batteries, but very high efficiencies would be necessary in operational transducers;
- seven, a protective coating for a case metal has been made, using existing industrial technology, which gave excellent resistance to chlorine attack; it is likely that protective coatings can be made for operational batteries;
- eight, another alkali metal-halogen cell (Li | Cl<sub>2</sub>) was run, using the same cell materials, equipment, and techniques as for the sodium | chlorine cell. It yielded an open-circuit value of 3.52 volts and

good load voltages at currents as high as about 12 amperes per square inch. The impact of this result is primarily on the "Cold-Cell" battery considerations and it means that even better energy densities might be capable of achievement due to the higher open-circuit voltage, the better electrolyte conductivity, and the lower atomic weight of lithium compared to sodium.

Furthermore, a lower operating temperature could be used, i.e., about  $650^{\circ}\text{C}$  versus about  $825^{\circ}\text{C}$  for the sodium | chlorine cell.

nine, the component parts of these cells were made with readily available, low-cost materials, consequently, material costs for operational batteries would be expected to be small. Furthermore, no catalyst of any kind is necessary to achieve excellent kinetic behavior.

## RECOMMENDATIONS

The theoretical studies undertaken and reported in Part I showed the total transducer and the "Cold-Cell" battery concepts to have inherently significant advantages in their respective areas of application, if they could be engineered successfully. Furthermore, successful development of "Cold-Cell" batteries, based on the alkali metals and the halogens as reactants, should represent a major advance in the packaging of electrochemical power. The laboratory work done and reported in Parts I and II has demonstrated, to the extent possible, that the very high electrochemical energy yields anticipated for "Cold-Cell" batteries should be capable of realization in practical devices, and no fundamental obstacle to successful development has been found. For these reasons, continued work is recommended, with work on the "Cold-Cell" battery portion of the system taking precedence as being worthy in its own right and as providing a necessary step in the development of the total system. Also, of course, experimentation would be easier at the lower temperatures.

Three areas are specifically recommended for early attention:  
one, continued study of laboratory cell performance;  
two, continuation of container materials studies;  
three, battery design studies.

Item one would utilize the best available laboratory cell designs to enable accumulation of the following information: limiting Faradaic and voltage efficiencies of the cells and electrodes as a function of current density and electrode spacing, suitability of other materials for electrodes, better design of pore size and total pore area, and life of electrode materials.

Container materials studies would be directed at obtaining better ceramic insulating materials to serve as spacers for the electrodes, better protective coatings for metallic cell case materials, as well as the materials themselves, and means of obtaining satisfactory carbon-to-metal and ceramic-to-metal seals at the necessary junctures. These studies should include life

testing of the materials and seals in the appropriate reactant or reactant-electrolyte environment.

Items one and two would be directed at providing the best possible basic cell designs for electrical performance and life.

Battery design studies, while presupposing adequate unit cell designs as a result of the other areas of investigation, are recommended for study in parallel. This would enable anticipation of problems which might arise from multi-cell design and scale-up, and which might arise in manufacturing parts and cells, such as molding and machining of metals and ceramics, sealing of component parts, application of protective coatings, design of inter-cell connections to provide high current carrying capability, introduction of reactants and removal of products, battery insulation, packaging, and so forth.

Work in these three areas, if done concurrently, would allow most rapid development of these new battery systems and would provide a firmer basis for continued work leading toward total transducers.

## DATA

Areas of experimental investigation are divided into: materials, the sodium electrode, "U" tube cell studies, and design and test of a cell of more sophisticated design which could lead to laboratory prototype "Cold Cells". The materials studies were concerned with providing cell cases not subject to attack by chlorine and achieving bonds between carbon and metals to enable fabrication of cells of advanced design. The sodium electrode work consisted in a search for materials and methods of fabrication of porous electrodes to enable electrochemical kinetic performance data to be obtained. The "U"-tube cell studies were made preliminary to laboratory cell studies of more advanced design, because the "U"-tube design allowed satisfactory measurement of open-circuit voltages, variation of e.m.f. with temperature, information on kinetic behavior, and advance information on some materials, without the necessity for waiting on solutions to sealing problems and others which would be of concern in prototype designs. The final cell design tested represented a compromise. It was desired to obtain electrochemical performance data on cells with porous electrodes of larger area and with a narrow electrolyte spacing which would be more representative of practical flat plate designs than the "U"-tube. Sealing problems were not solved, however, so it was attempted to achieve the same result by constructing a cell in which the component parts were pressure-sealed by clamping in a vise-like device.

### Cell Case Materials

In Part I of this report (Reference 1) it was shown that containing materials exist for these reactive elements. It was also shown that further studies of materials were necessary to allow construction of an operating cell. The objective of these studies was discovery of an electronic conductor which would be suitable for the end of the cell case containing halogen gas. A further objective was the investigation of means to bond carbon to this metallic conductor.

The need for a metallic case end was based on design considerations in which advantage was taken of the ease of fabrication, and the high electrical conductivity of metals. These characteristics were to be compared with those of carbon, which is not malleable nor highly conducting. Although carbon will remain the best material for the halogen electrode proper, because of its non-wetting characteristic in contact with fused halide salts, an increase in cell voltage and a decrease in cell volume should result from the use of a metal battery case. Thus, a metal was needed which would not be attacked.

Therefore, a program of corrosion studies of likely metals and alloys was undertaken. The halogen gas chosen for these corrosion tests was chlorine. based upon the conclusions reached in Part I of this report and also because, of the usable halogens, chlorine gas at 825°C represents the most corrosive environment likely to be experienced. Therefore a solution to the containment problem for chlorine would probably represent also a solution for bromine and iodine.

The test applied consisted of passing dried chlorine gas through a high-silica content glass tube (Supplier Code 4) in which was placed the sample metal. The sample was usually in the form of a cylindrical bar, 1 inch in length and  $\frac{1}{4}$  inch in diameter. The glass tube was heated in an electric furnace and provision for maintaining an inert atmosphere was made. The inert atmosphere was maintained until the test temperature of 825° - 850°C, as measured by a chromel-alumel thermocouple, was reached at which time the atmosphere was changed to chlorine. The chlorine was allowed to remain in contact with the sample at a pressure of one atmosphere for a measured length of time, usually 15 minutes. After this period the chlorine was displaced with the inert gas, either argon or helium, and the sample was cooled to room temperature. The extent of attack was measured by observing the change in weight of the sample.

The results of these tests are presented in Table 1. The corrosion rate reported is based upon the observed change in weight, which was then divided by the product of the original area of the sample multiplied by the time of

Table 1 Results of Corrosion Tests

Corrosion Test Data - 350°C

Supplier Code	Composition	Initial Weight gm	Final Weight gm	Weight Loss gm	Area in <sup>2</sup>	Reaction Time min	Corrosion Rate
1	Wc + Ag	2.4152	2.4239	+0.0087		30	+
1	Wc + Ni	16.7870	15.8007	0.9863	0.965	8	-7.76 gm/in <sup>2</sup> hr
1	Wc + 10% Pt	1.8653	0.8354	1.0299	0.326	10	-19.0 "
1	W + Ag	3.1771	1.8088	1.3683	0.284	30	-9.63 "
1	W + Wc 0.002	3.9701	3.4036	0.5665	0.294	60	-1.86 "
1	W + Wc, 0.001-.002	3.9368	2.9688	0.9680	0.294	55	-3.58 "
1	W - mk grade	4.2688	4.0694	0.2039	0.405	20	-1.51 "
1	W - ha grade	20.1907	19.5985	0.5922	1.726	20	-1.02 "
1	Pd	2.1779	1.5195	0.6584	0.69	15	-3.82 "
1	Pd-95%, Ra-5%	1.3981	0.5565	0.8416	0.694	15	-4.85 "
1	Ta	0.1458	0.0	0.1458	0.125	3	-23.3 "
1	W-4 powder	1.1765	0.7379	0.4386	-	15	-1.75 gm/hr
1	W-1 powder	0.7974	0.4163	0.3811	-	15	-1.52 "
1	Wc-1 powder	0.9205	0.6138	0.3067	-	15	-1.23 "
1	Wc-3 powder	1.0911	0.8531	0.2380	-	15	-0.952 "
1	W <sub>2</sub> C 10-20 mesh	3.6233	2.1722	1.4511	-	15	-5.81 "
2	W + Ni + Cu(W-2)	9.9590	8.9891	0.9699	0.669	15	-5.78 gm/in <sup>2</sup> hr
2	Wc (K601)	7.7495	7.4415	0.3080	0.736	15	-1.67 "
2	TiC + Ni (K151A)	11.3166	10.8605	0.4561	1.774	15	-1.02 "
2	TiC + Ni + Mo(Sp-114)	1.4010	1.1922	0.2088	0.446	30	-0.937 "
3	W	15.4902	14.2290	1.2612	0.885	180	-0.476 "
3	Mo	8.2402	6.5346	1.7056	0.883	10	-11.6 "
Stainless Steel (304)		2.4749	3.3778	+0.9029	-	5	+
	Pt	0.8765	0.8719	0.0046	0.50	180	-0.0034 "
	Ni	-	-	0.4858	0.805	5	-6.95 "
	Au	1.2196	1.1985	0.211	0.328	30	-0.129 "

the corrosion test. In all but two cases, a weight loss was observed due to the formation of volatile chlorides. In the case of the tungsten carbide alloy containing silver, the weight gain resulted from the formation of AgCl, which was molten at the test temperature and adhered to the sample. The stainless steel was attacked at a high rate and not all the chlorides of iron volatilized. The rate of attack for the tungsten powder is reported on the basis of weight loss alone, since the area was not determined. In the series of tests of tungsten powder, it was the object to correlate the rate with particle size. The expected correlation was observed: the smaller the particle size, the greater the weight loss for equivalent conditions.

The results reported in Table 1 show that platinum and gold exhibit the lowest corrosion rates. None of the remaining metals and alloys tested showed satisfactory resistance to chlorine attack. The use of platinum or gold was rejected because of previous experience which showed that these metals form soluble complexes in the presence of the alkali metal salts. Because the interior of the cell may be expected to be coated with such salts, due to volatilization, the use of gold and platinum was precluded. Had this complex formation not been found to be the case, the use of these precious metals might still have been excluded on the basis of cost.

#### Case Materials, Protective Coatings

These results indicated that another approach to the use of a metal case end was necessary. Because glass utensils have repeatedly been employed in these tests with no observable attack, it was decided to investigate the use of a silaceous coating on a metal. By this approach the advantages of a metal end could still be retained while avoiding further search for corrosion resistant metals, if a successful coating were found.

Because the bonding of glass to tungsten is a well-known glassblower's art, it was decided to study the feasibility of this approach to achieving a protective coating for a metal case. Samples of pure tungsten (Supplier Code 1) were coated with borosilicate glass (Supplier Code 4). The technique

employed was that common to the glassblower's art and the resulting bond was vacuum-tight and withstood extremes of temperature change. The color of the bond was a golden tan. Five samples were prepared as follows:

1. Coated Bar 2.214 cm long, 0.380 cm diameter, coated completely
2. Coated Bar 2.214 cm long, 0.380 cm diameter, coated except for ends
3. Coated Bar 2.214 cm long, 0.380 cm diameter, coated completely and then glass cut through in center.
4. Uncoated Bar 2.214 cm long, 0.380 cm diameter.
5. Coated Wire 6 cm long, 0.1 cm diameter, coated except for cut ends.

These were exposed to chlorine gas for 15 minutes at 825°C with the following results:

1. Initial weight 5.8096 gms, final weight 5.8096 gms. No detectable weight loss.
2. End attacked. Color of bond no longer present for a length of 0.35 cm. Rest of surface still bonded.
3. Center attacked. Bond destroyed over a circular area of 0.29 cm radius.
4. Initial Weight = 4.0752, final weight = 3.8108 gm. Loss = 0.2644 gms. The major attack occurred on the ends yielding a cavity of at least 0.1 cm depth. The corrosion rate, based on end-only attack corresponds to 30.2 gms/(in<sup>2</sup>hr). If entire area considered, the rate corresponds to 0.269 gms/(in<sup>2</sup>hr).
5. Weight loss = 0.0057 gms. Penetration occurred from ends for a length of 0.39 cm.

These results are in agreement with other observations which indicated that grain orientation influences corrosion rate. Thus the ends of these power-metallurgy bars were attacked at a greater rate than the surface. Most significant, however, was the absolute lack of attack on the completely coated bar. No visible or measurable change was noted. Thus, it was concluded that a protective coating for tungsten had been found and that further investigation was in order.

Tungsten disks, 0.5 inches diameter, 0.040 inches thick, were obtained

(Code 1, a). These were placed in borosilicate tubes, heated under vacuum to 400°C, treated with hydrogen gas at 1 atmosphere pressure, re-evacuated, and cooled. Each disk was then raised to a temperature between 400 and 500°C under vacuum. After a constant temperature had been attained, oxygen at one atmosphere was introduced for 5 minutes to 30 minutes, after which the tube was again evacuated and the disk cooled. The oxide coatings thus formed varied in thickness and color. The film formed at 400°C after 30 minutes oxygen exposure most resembled that obtained using the usual glassblower's art.

The tungsten disks, treated in this fashion, were then covered with glass powder. This powder was made by grinding borosilicate glass with a mortar and pestle, followed by screening. The size of the powder was such that it passed through a 100 mesh screen and would not pass through 150 mesh. After laying a film of glass powder on one surface, the disk was placed in a muffle furnace at 1000°C. After 15 minutes exposure, the disk was removed from the furnace.

The conditions employed were varied somewhat in attempts to obtain a smooth, clear, and adherent surface of glass. None of these attempts provided satisfactory results, however. The best coatings obtained had the appearance of a foamed glass. Examination with a microscope disclosed that a uniform wetting of the tungsten surface had occurred in some cases, and that the bond color was correct. The character of the coating was not satisfactory for protective coating surfaces however. Forming these glazes in a vacuum muffle might have yielded more satisfactory results.

The use of glazes for protective and decorative coatings on metals is a wide-spread industrial practice, and manufacturers of these products were contacted. The objective, i.e., a borosilicate glaze on tungsten metal, was explained to these suppliers (Codes 5 through 11). After sufficient exchange of information, it was learned that none had the facilities for producing such a glaze. However, several suppliers (Codes 5, 6, 9, 10 and 11) were willing to try proprietary formulations to achieve a protective glaze. Samples of tungsten (Code 1, a) were sent to these suppliers. Of these attempts, suppliers (Code 5 and 9) reported that initial attempts had been promising and that such a

glaze was possible. Development, however, could not be undertaken unless production interests were involved.

Suppliers (Code 6 and 11) returned the tungsten disks with coatings. Neither of these coatings were found to be satisfactory. Both coatings behaved in a similar manner; the results of tests on the disks received from Supplier (Code 6) are shown in Figures 1, 2, and 3. The dime-sized tungsten disk was completely covered on both sides and edges with a fire-polished surface as shown in Figure 1. These disks were then heated in an argon atmosphere to 800°C for 15 minutes, after which treatment the glaze had bubbled and had tended to ball, as shown in Figure 2. The disks were then re-heated and exposed to a chlorine atmosphere for 15 minutes. After this treatment, the glaze was found to have been completely separated from the disk, as shown in the top row of Figure 3. The other disk had suffered less attack, but the tungsten surface was exposed with consequent corrosion, as shown in the bottom photograph of Figure 3.

These results indicated that, although a protective and adherent coating for tungsten can be made, present industrial glaze formulations will not suffice. The reason that tungsten had been chosen is that this metal has a coefficient of thermal expansion which matches that of the aluminum oxide parts of the cell, and that it was known that a glaze could be applied. However, other metals can be used as the case end for a "Cold Cell", and a further search for a protected metal was made. A sample of a recently developed ceramic glaze was obtained from a Supplier (Code 12). This glaze is an adherent coating applied to a base metal, which, in the case of the sample supplied, was nonferrous. The configuration of the test sample, as received, is shown in Figure 4. This sample was treated as the others were, being first heated to 825°C in helium for one hour, cooled, weighed, then reheated and exposed to chlorine for 15 minutes. A carbon collar was used as a support during the treatment to prevent adhesion of the sample to the glass tube. Suitable carbon supports were also employed in all other glaze-testing runs.

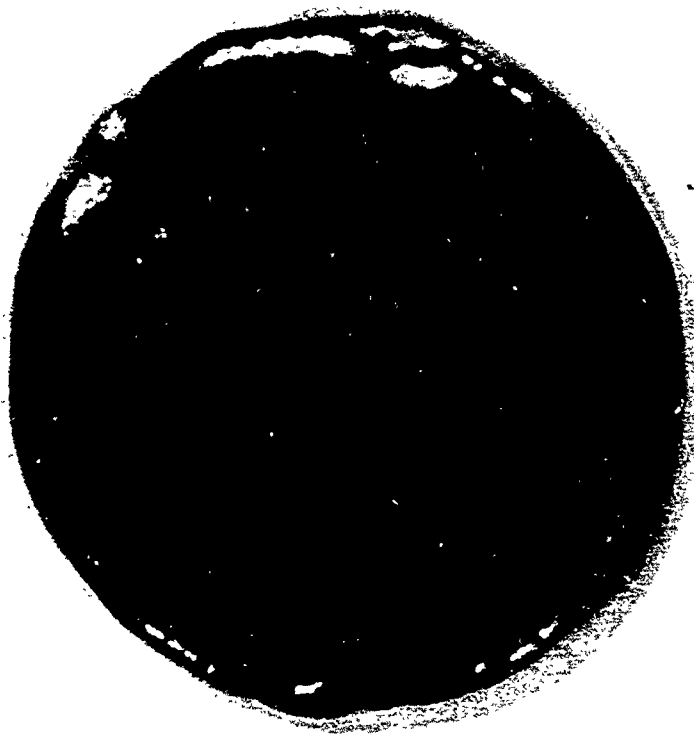

Figure 1 Photograph of Ceramic-Coated Tungsten Disk as Received

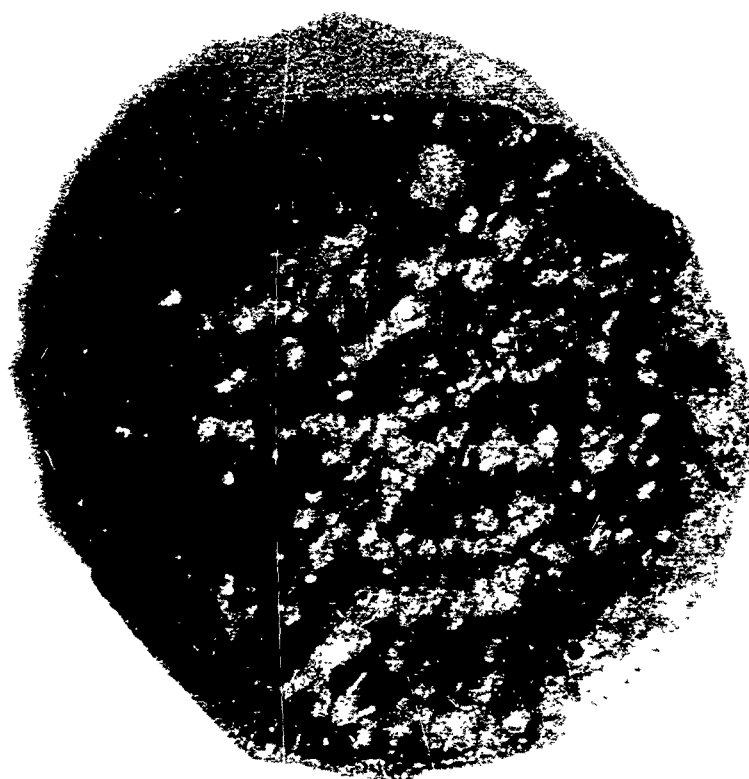

Figure 2 Photograph of Ceramic-Coated Tungsten Disk After Heat Treatment at 800°C

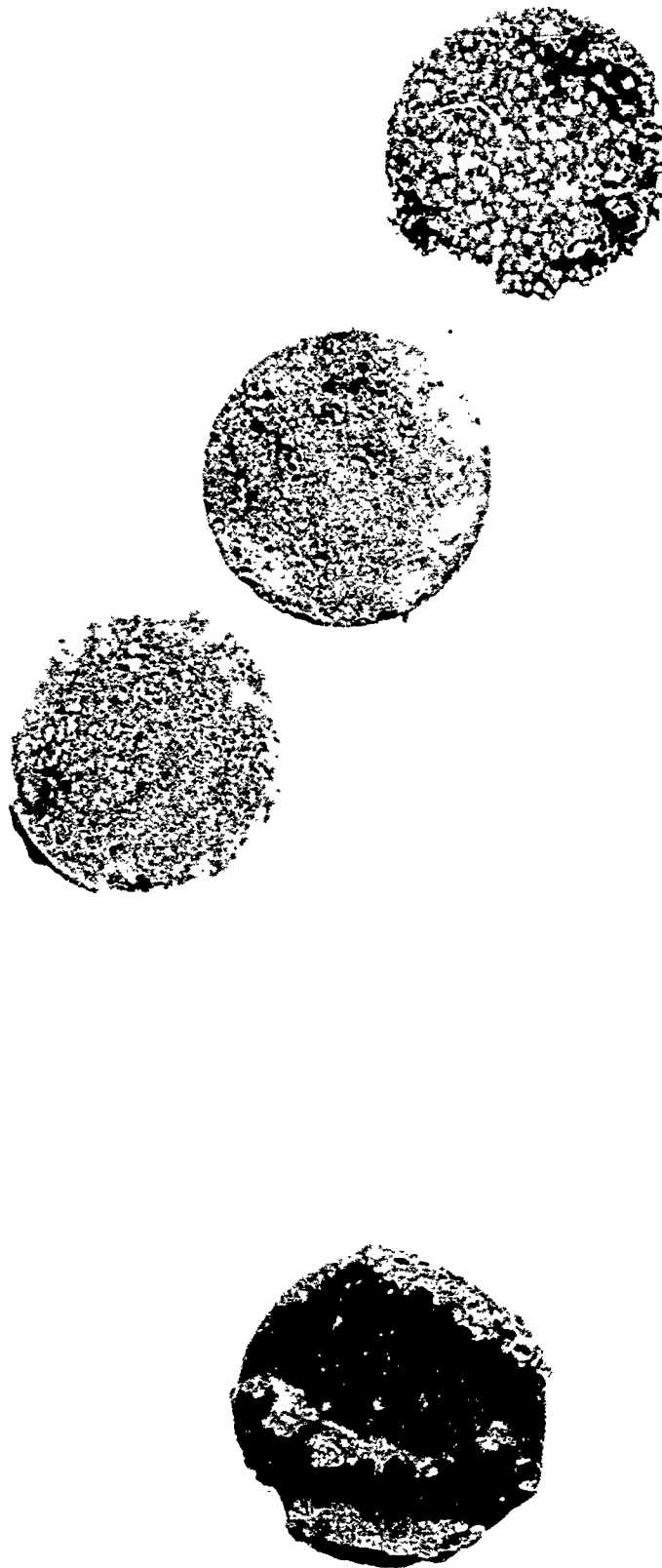

Figure 3 Photograph of Ceramic-Coated Disks After Exposure to  $\text{Cl}_2$  at  $800^\circ\text{C}$

(Top: Photograph showing separation of glaze from W disk  
bottom: Photograph showing agglomeration of glaze.)

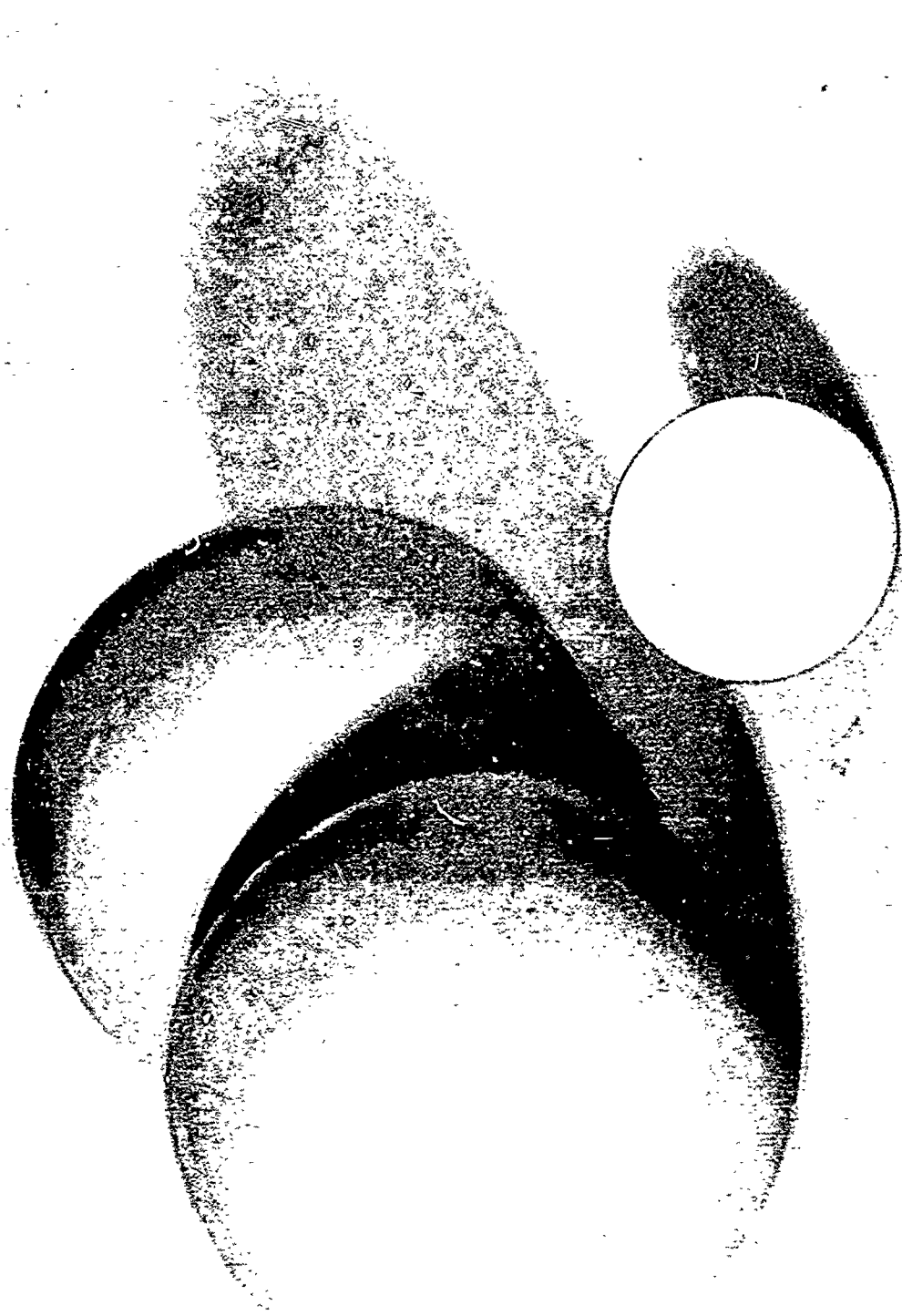

Figure 4 Photograph of Ceramic-Coated Dumbbell

Figures 5 and 6 are photographs of this dumbbell-shaped sample after exposure to helium. It is apparent that no bubbling occurred in the glaze. The dark areas in the upper half which look like cracks (Fig. 5) were not cracks at all but deposits of carbon which were readily wiped away with tissue paper. Such deposits are generally observed if carbon parts are not heated and purified before being put in test vessels. The bottom of the dumbbell (Fig. 6) shows the deformation of the glaze due to pressure exerted on the glaze by the weight of the dumbbell on the carbon collar. It is apparent that the glaze becomes sufficiently plastic at 825°C to allow deformation. The metal substrate was exposed by this flow.

After testing the behavior of the glaze under helium, the dumbbell was reheated to 825°C and exposed to chlorine gas at one atmosphere pressure for 15 minutes. The effect of the chlorine is shown in Figures 7 and 8. The top of the dumbbell remained unaffected except for a few shallow pin holes. The surface was no longer smooth, showing evidence of interior bubbles (Fig. 7). The bottom of the dumbbell was attacked, as expected, in the region of the carbon collar. The attack, however, did not seem to penetrate beneath the interface of the glaze and the metal, except where the carbon touched the dumbbell. The glaze had fractured in conchoidal chips, characteristic of silaceous materials, but the base metal was relatively free of corrosion pits. The coefficient of expansion of the glaze is lower than that of the base metal, so that stresses are established when the dumbbell cools. The uniform ring of attack corresponds to what might be expected from such an object if stress were uniformly relieved as was done by the carbon ring.

The weight of the dumbbell before testing was  $416.2 \pm 0.1$  grams. After testing in helium it was 416.1 grams and after testing in chlorine, it was 413.1 grams. The weight loss appeared to be due to loss of the glaze, as determined by visual examination.

Microscopic studies of the bond were made. The dumbbell was sectioned along the axis of rotation as shown in Figure 9. The diameter of the dumbbell was 3.8 cm. and the thickness of the glaze was no more than 0.08 cm. It was colored dark brown to black at the metal interface and brown at the surface.



Figure 5 Photograph of Dumbell After Exposure to Helium at 825°C. Top View



Figure 6 Photograph of Dumbbell After Exposure to Helium at 825°C.  
Bottom View

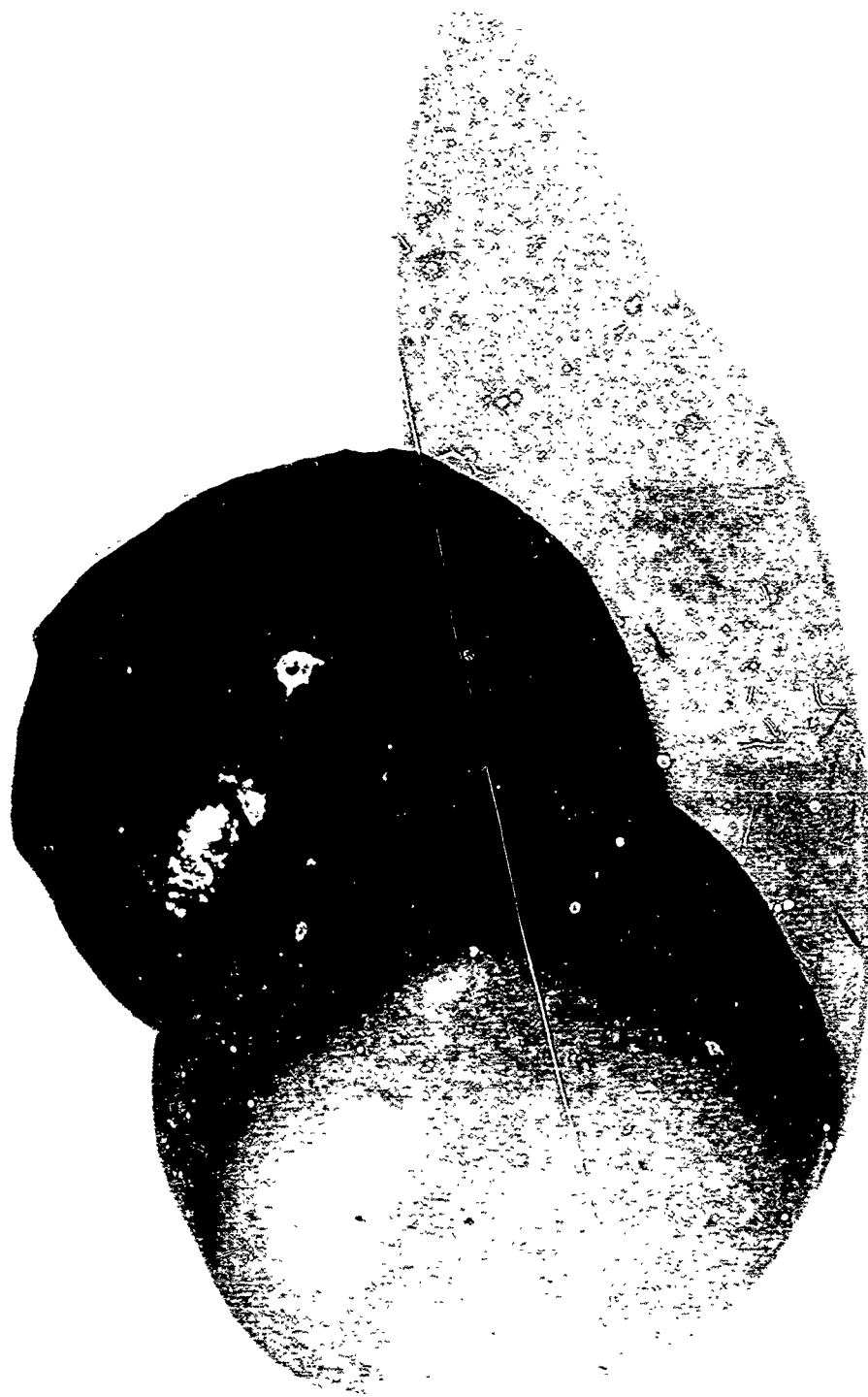

Figure 7 Photograph of Dumbell After Exposure to  $\text{Cl}_2$  at  $825^\circ\text{C}$ . Top View



Figure 8 Photograph of Dumbell After Exposure to Cl<sub>2</sub> at 825°C  
Bottom View

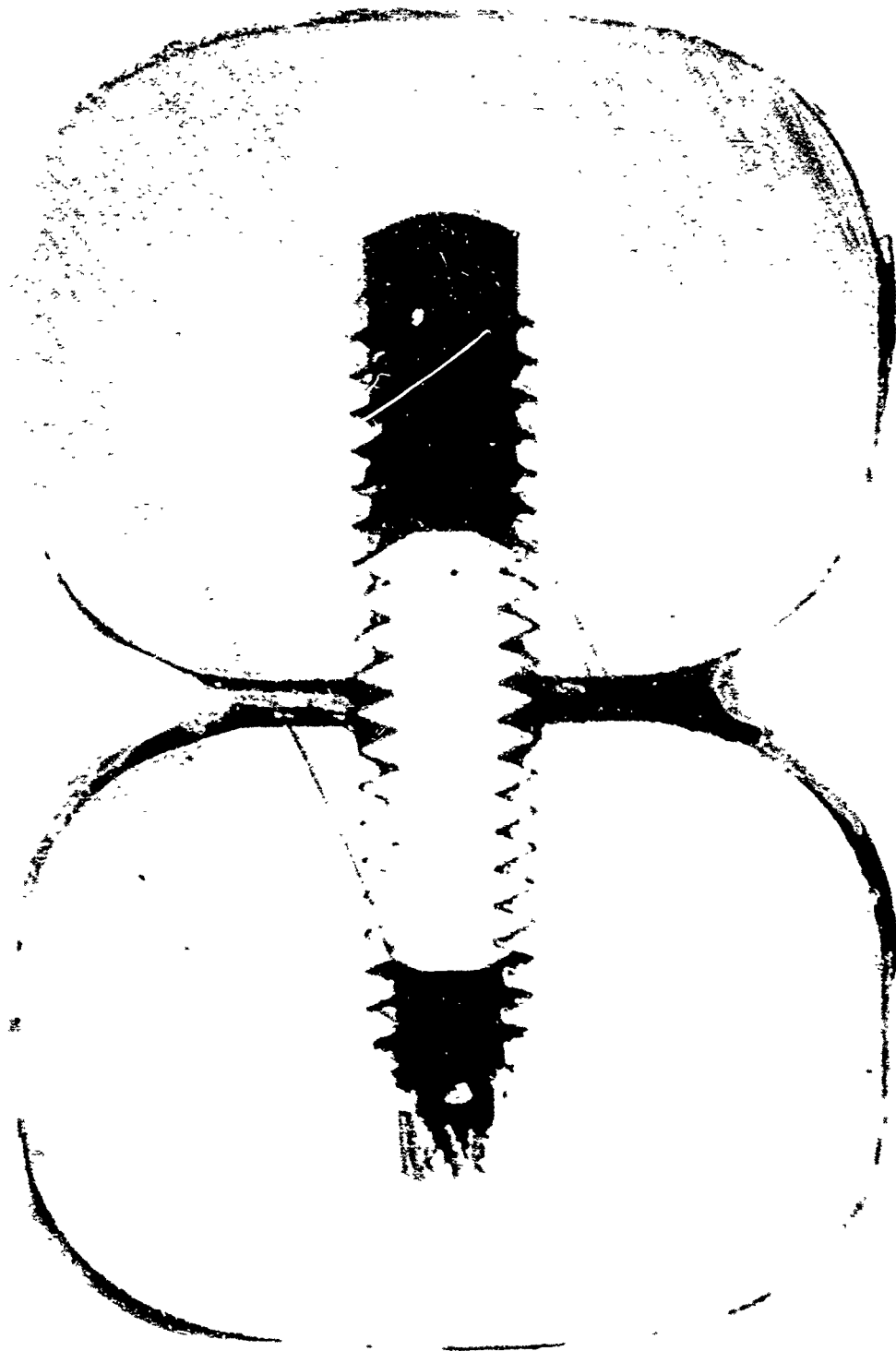

Figure 9 Section of Dumbbell After Treatment

Surface examination indicated bubbles (Figure 7) and the bubbles were found to exist to the metal surface (Figures 10-12). No continuous capillaries were found, however.

A section of the base metal to glaze interface was examined using metallographic techniques. The photographs shown in Figures 10, 11 and 12 show this region at an approximate magnification of 180 times. Figure 10 shows the bond region with the base metal (C) to the right of the figure and the glaze (B) in the center. The plastic (A) used to mount the specimen is shown on the left. The bubbles are quite evident in this photograph, and no continuous path is apparent. Figure 11 shows the same region displayed with polarized light. Here the bonding between the ceramic and the base metal is more apparent. The dark band (D) may correspond to a diffusion of base metal oxides into the ceramic body. If so, this bond is quite similar in nature to the tungsten-glass bond. Figure 12 shows the same area as before, but after the base metal had been chemically etched. Although not conclusive, there appears to be a layer of oxide diffusion to the base metal. If so, this bond would be expected to be of the most mechanically strong variety.

The glaze just described (Supplier Code 12) shows promise as an effective protective coating for metals to be used in battery construction. This first examination yielded results which warrant further study in this application.

A sample of another glaze was obtained from supplier (Code 13). This sample consisted of a metal bar 31 cm. in length and 0.322 cm. in diameter with a very thin ceramic coating. The glaze was very smooth, with a lustrous fire-polished finish. It was green in color. A photograph of a portion of the bar, as received, is shown in Figure 13. This bar was treated in the same sequence as previously described. Because of the length of the bar, it was necessary to enclose the bar in a glass tube which was heated in the center only. The length of the heated tube was 12 cm; thus, about 5 cm. of the bar protruded from the hot zone to a zone at about room temperature. This subjected the bar to a stress, resulting from temperature gradients, to which the other glaze samples had not been subjected. Such thermal gradients would not normally be expected to be present in an operating cell of adequate design. Therefore, this test did not represent as valid a set of conditions as pertained

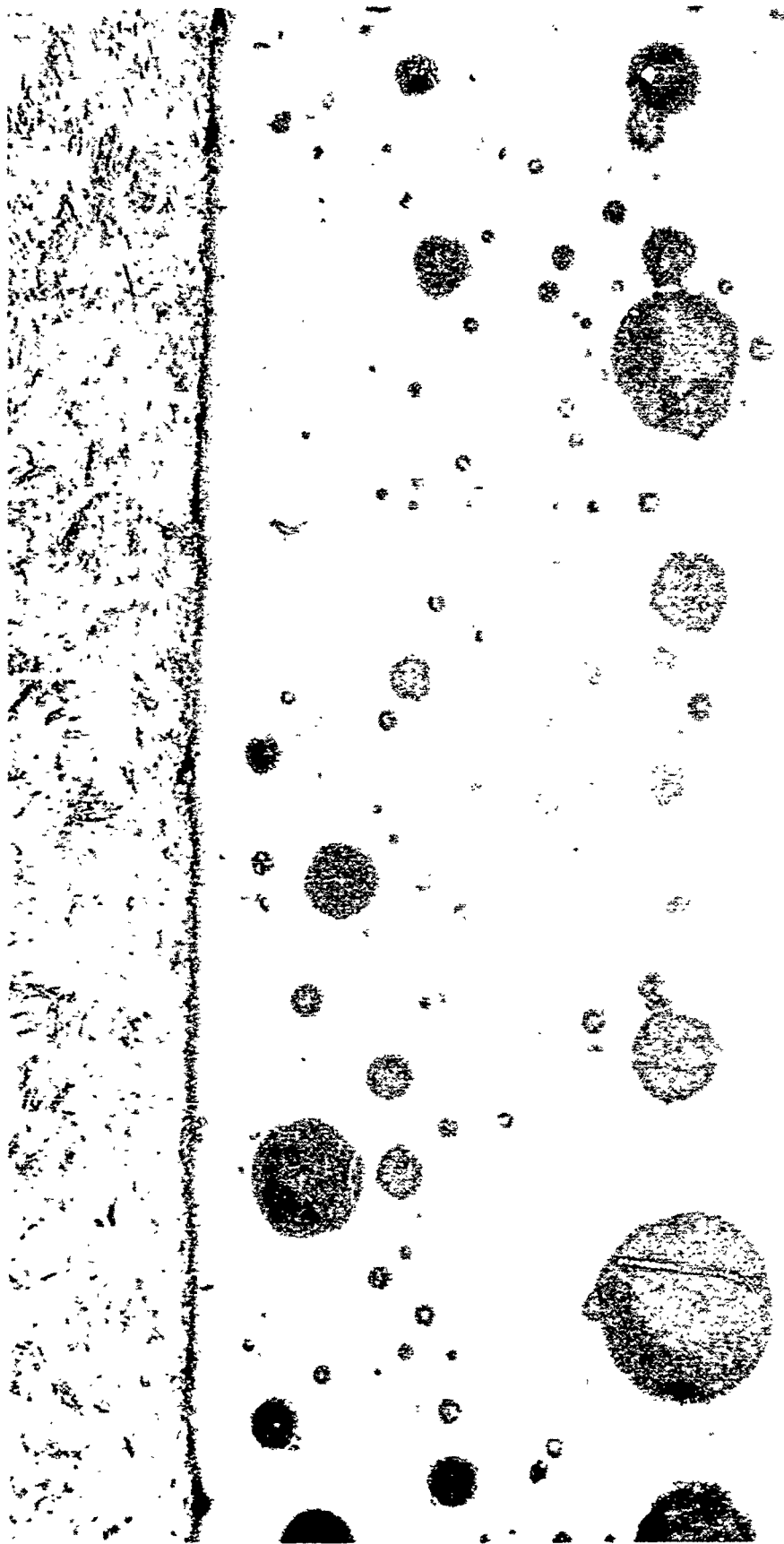

Figure 10 Photomicrograph of Dumbbell-Glaze Interface

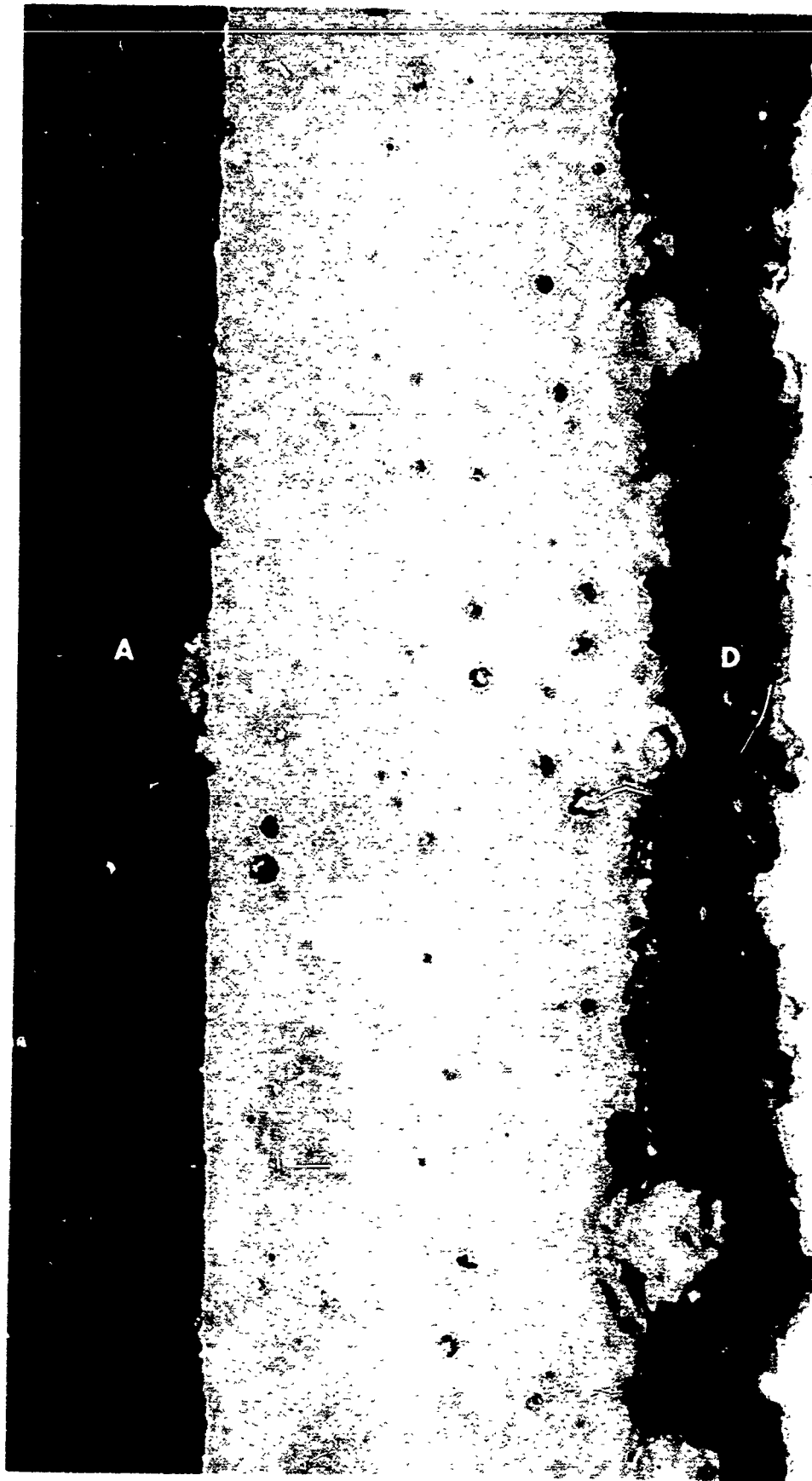

Figure 11 Photomicrograph of Dumbbell-Glaze Interface Polarized Light



Figure 12 Photomicrograph of Dumbbell-Glaze Interface Polarized Light  
Chemical Etch



Figure 13 Photograph of Ceramic-Coated Bar

to the dumbbell and the other samples. No change in appearance or weight occurred after subjecting the bar to an argon environment at 825°C. The glaze failed, however, to protect the bar from Cl<sub>2</sub> attack during a 15-minute exposure, as shown in Figure 14. The weight loss of the bar was quite small, only 0.04 gms., and the glaze itself was not visually attacked. When removed from the furnace, the glaze, still green in color, was separated from the rod and had cracked in many places. The cracked glaze was removed and the photograph of Figure 14 taken.

While the glaze failed to adhere to the metal in this case, it is considered that the test technique itself may have induced failure.

Some other material tests performed deserve brief mention here. One of these concerns a fluorine-containing elastomer (Supplier Code 14), which was obtained in the form of "rubber" tubing. This tubing was found to be unattacked by chlorine and sulfuric acid at room temperature. It was useful in making short connections between glass tubing and for making similar connections to sulfuric acid bubblers used in the gas purification train. This same elastomer was also found to be unattacked by metallic sodium at 145°C.; however, this test was performed out of curiosity and with great caution, since the explosive reaction of halogen-containing organics with the alkali metals is well known, and the reader is advised that this brief test is considered inconclusive. This elastomer also withstood a temperature of 350°C. in argon without noticeable decomposition during the test exposure.

#### Materials, Bonding Techniques

The development of an integral cell requires a study of combining cell parts into a whole, so studies of coefficients of expansion and bonding techniques were made toward this end.

A diffusion bond between alumina and niobium was developed and reported in Part I (pps 122-125). This bond could be useful in cell construction and was actually tested in cells made for conductivity measurements.



Figure 14 Photograph of Ceramic-Coated Bar After Exposure to Cl<sub>2</sub> at 825°C

Experimental equipment and procedures have been described in the above pages of reference 1.

The conductivity cell assembly was fabricated by "heliarc" welding of the diffusion-bonded seal to the rest of the solubility assembly. The seal and related assembly was then heated to 800°C and then increased in temperature to 1080°C. High leak rates were observed at the higher temperatures and the run was concluded. Examination of the seal after the run showed that several radial cracks had developed in the ceramic body. No cracks had developed in the bond between the niobium metal and the alumina, however. The failure of the part is believed to have been due to stresses established in the heliarc process. If so, this bonding technique may be considered to be available for the construction of "Cold-Cell" batteries.

Considerations of the coefficients of thermal expansion are necessary because the completed cell must be heated from room temperature to the operating temperature. Furthermore, because carbon is likely to be employed as the chlorine electrode material, it is necessary to devise a method of sealing the carbon to an electronically conducting member of the cell case in simplest designs. United States Patents 2,431,975 and 2,158,845 and British Patent 504,078 describe the formation of a tungsten carbide bond between tungsten and carbon. These bonds, which are diffusion-type bonds, are made at temperatures above 1200°C. It is claimed in these patents that the bond is both stronger and more electrically conducting than the parent carbon. The following study was conducted to determine relative coefficients of expansion and bond formation between tungsten and carbon.

Figure 15 shows a photograph of the parts used in the study of expansion and bonding. The parts are, from left to right, an aluminum oxide plug, a carbon plug, a tungsten ring, and a complete assembly, consisting of a carbon plug inserted into a tungsten ring. The plugs were made from one-inch diameter stock, and a five-degree taper was machined along half the one-inch height. The tungsten rings were made as shown with an internal taper which was ground to match the taper of the plug.

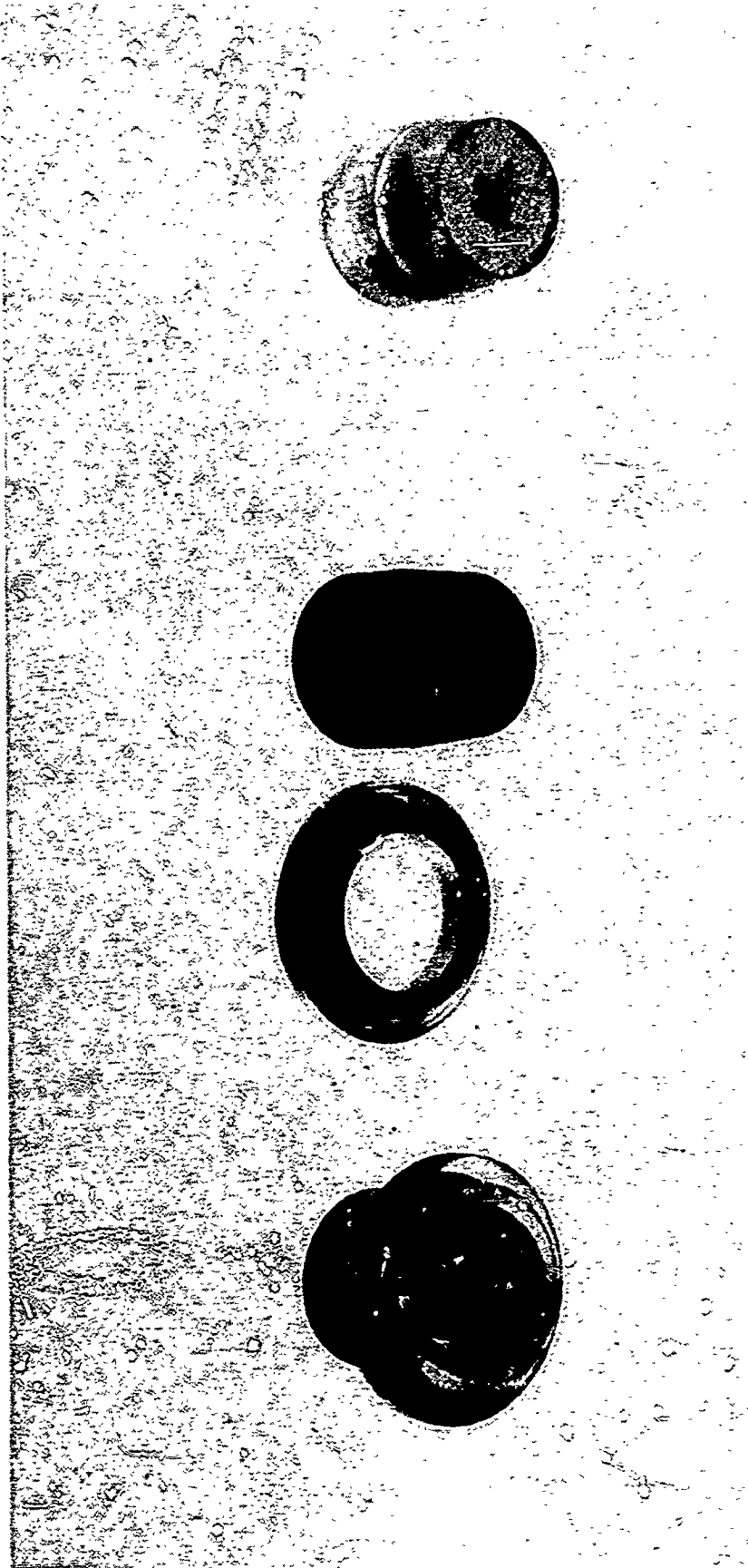

Figure 15 Photograph of Parts Employed in Bonding and Expansion Studies

-----  
-----  
-----  
-----  
-----  
-----  
-----  
-----  
-----  
-----

The test consisted of pressing a plug firmly into a tungsten ring. The assembly was then heated to test temperature, left at temperature for a measured length of time, and then cooled. Two measured values were then available: the difference in heights between the plug and the ring measured before and after heating gave a measure of the relative coefficients of expansion, and a study of the bond between the ring and the carbon plug yielded bonding data.

The coefficients of linear expansion of materials at elevated temperatures are uncertain. The coefficient used in design studies (both Part I and II) have been: tungsten,  $4.5 \times 10^{-6} / ^\circ\text{C}$ ; carbon,  $3.96 \times 10^{-6} / ^\circ\text{C}$ ; and alumina,  $4.5 \times 10^{-6} / ^\circ\text{C}$ , averaged over the range of room temperature to  $800^\circ\text{C}$ . The match between alumina and tungsten is one of the reasons tungsten has been of interest in these studies. In the experiment just described, the tungsten ring would have slipped down on the plug when heated, if the coefficient of expansion of the plug were less than that of the ring. From the above data it would be expected that the ring would not move on the alumina plug but would move on the carbon plug. The diameter of the plug, at the upper point of contact, was 0.9135 inches. The diameter of either the plug or the ring at the maximum temperature may then be expressed as

$$D = 0.9135 \alpha (T - 25^\circ\text{C}) + 0.9135$$

where  $\alpha$  is the average coefficient of linear expansion. If the difference in the diameters, hot, between the plug and the ring is  $\Delta D$ , then the ring will slip down the plug by a change in height  $\Delta h$ , given by

$$\Delta h = \Delta D (2 \tan 5^\circ)^{-1}$$

From these equations, knowing the distance the ring slipped on the plug, it is possible to calculate the difference in coefficient of expansion between tungsten and the plug. The results, using a value of  $\alpha$  of  $4.5 \times 10^{-6} / ^\circ\text{C}$  for tungsten, are reported in Table 2. The difference between these values and those quoted previously in the text is probably due to lack of precision in the technique in measuring  $\Delta h$ . Discrepancies

Plug	Maximum Temperature °C	Time at Maximum Temperature min.	Height Change in.	Coefficient of Expansion Relative to Tungsten at $4.5 \times 10^{-6} / ^\circ\text{C}$
Al <sub>2</sub> O <sub>3</sub>	800	32	0.0041	$3.5 \times 10^{-6} / ^\circ\text{C}$
C	800	32	0.0061	$3.0 \times 10^{-6} / ^\circ\text{C}$
Al <sub>2</sub> O <sub>3</sub>	1500	30	0.022	$1.6 \times 10^{-6} / ^\circ\text{C}$
C	1500	30	0.003 *	$4.1 \times 10^{-6} / ^\circ\text{C}$

\* no bond formed

Table 2 Coefficient of Expansion Data

between the data at 800°C and that at 1500°C might also be due to a relative difference in rate of change in coefficients of expansion between carbon and tungsten and between alumina and tungsten. More precision could be gained by use of larger diameter rings and a smaller angle of contact.

As mentioned, bonds between carbon and tungsten, due to formation of tungsten carbide, have been observed to form at temperatures above 1200°C. Examination of the interface between the carbon plugs and the tungsten rings, after treatment at either 800° or 1500°C, showed no evidence of bond formation. The techniques employed in the literature used a paste cement of carbonaceous materials, usually sugar, in a water solution to effect the bond. It may well be that such a cement is necessary, and this remains to be investigated.

#### Electrode and Laboratory Cell Studies

The preliminary studies reported in Part I showed that short-circuiting of cells, due to solubility of sodium in the electrolyte at temperatures above the melting point, was not probable and also demonstrated the high-current capabilities of chlorine electrodes. The next logical objective for a laboratory program was the construction and testing of complete cells made with both sodium and chlorine electrodes. From these studies, an experimental demonstration of the open-circuit voltages, the current-yielding capabilities of the cell, and voltage change with temperature to the extent and manner called for in the theoretical considerations involved with the concept of the Electrothermally Regenerative Transducer would be provided. After these studies, the laboratory study of cells could be extended to alkali metals and halogens likely to be more suited to batteries, or fuel cells, than to the transducer. This program has been followed and is reported below.

## Sodium|Chlorine Cells

A series of tests were performed on cells using a sodium anode and a chlorine cathode. These studies were made using an alumina "U" cell. A total of six runs were made. The cell required a blanketing gas of either argon or helium and purification of the sodium chloride, which was "reagent grade" purity; this was necessary to remove oxides, hydroxides and water. A description of the gas train and a photograph of the laboratory equipment has been shown in Part I (p. 101). Not included in that description was the hydrogen chloride purification technique. Commercial cylinder hydrogen chloride gas was passed through a gas train of activated carbon and then through magnesium perchlorate. This dry gas was then bubbled through molten sodium chloride for one hour. This was followed by flushing the melt with argon, and evacuating the melt prior to freezing. Sodium chloride, prepared in this manner, which is similar to the method of Reference 2, was clear, colorless and did not adhere to nor etch the high-silica glass tube used as the container. The purified NaCl was transferred to a dry box filled with argon, ground to a powder and stored for use. Approximately 50 grams were prepared with each fusion.

Reagent grade sodium metal was used. It was handled in the dry box and no further purification was made. The experimental techniques for the measurement and control of temperature and for the measurement of cell voltage and current have been described in Part I of this report.

The alumina "U" cells were obtained from a supplier (Code 15) and were constructed as shown in Figure 16. The design of this cell was dictated by several requirements. The first of these was the diameter of the furnace available for this work. This diameter placed limit on the overall width of the cell. The chlorine

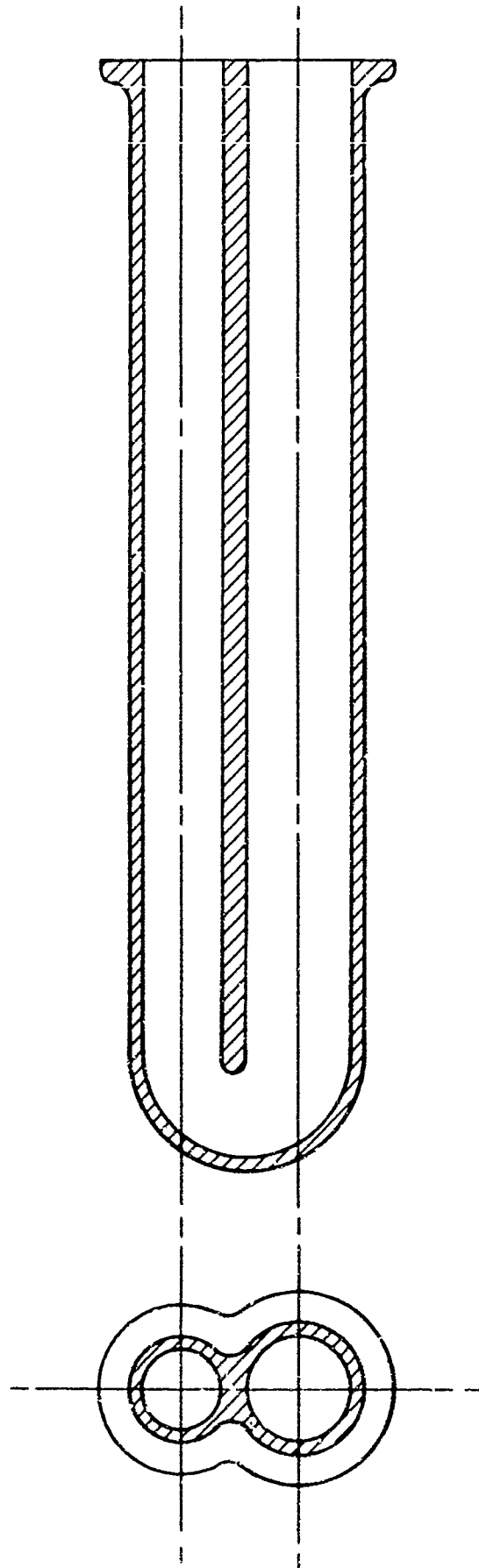

Figure 16 Drawing of Alumina "U" Cell

electrodes employed were those previously reported in Part I (pps. 98-99) and were obtained from a Supplier (Code 16). The diameter of these electrodes was 1 inch; this placed a minimum limit on the diameter of the cathode compartment. The smaller diameter was required to allow the cell to fit the furnace.

The second requirement involved in the design of the cell was that both anode and cathode compartments be at the same temperature. Thus the cell was designed with a single wall between the two compartments. This was a mistake. The thermal conductivity of the two compartments differed because of the differences in wall cross-sectional area and because of the differences in thermal conductivity of the electrodes employed. The two compartments could not be maintained at identical temperatures and the resulting stress caused eventual rupture. Further studies should be restricted to the use of "U" cells made of two parallel tubes of equal diameters (or other provision for maintaining equivalent temperature gradients).

The sodium electrodes employed were as shown in Figures 17 and 18. A nickel or iron tube was fabricated as shown. A disk of a porous-metal electrode, either nickel or iron, was placed against the flared end of the tube, a washer placed over the porous disk, and the circumference was heliarc welded (Supplier Code 17). The electrode thus formed allowed sodium to be introduced down the tube to the electrolyte. Studies of the effectiveness of the porous grid in retaining the sodium were thus possible. The rolled internal collar on the tube served as a valve seat for a ball valve which was put in place after the sodium was introduced. This valve prevented volatilization of the sodium to a cooler region in the tube. The chlorine electrode, the alumina "U" cell, and the parts for a sodium electrode are also shown in Figure 18.

The porous metal disks were obtained with different pore sizes and different materials. The particulars of these electrode materials are presented in Table 3.

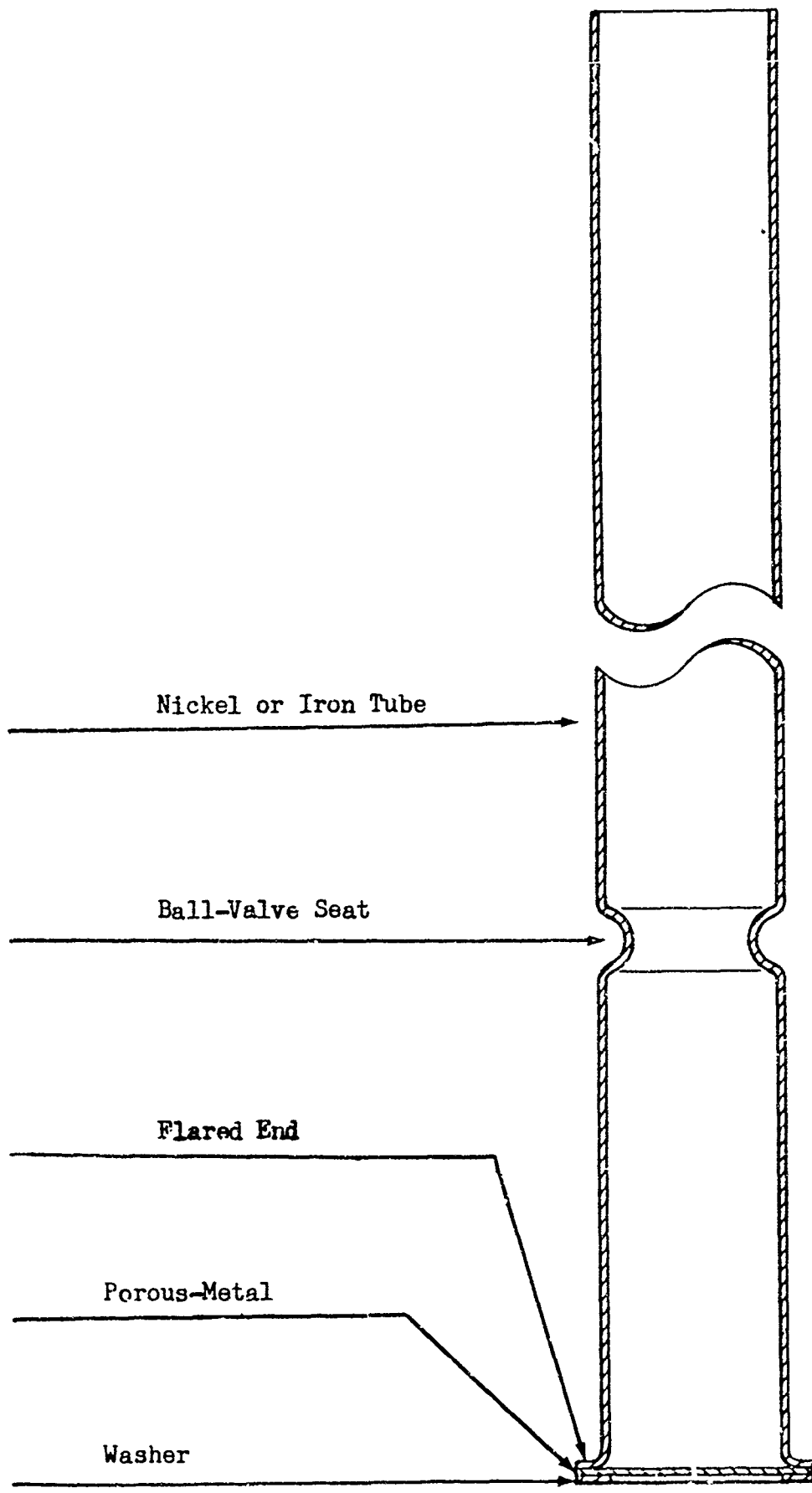

Figure 17 Drawing of Sodium Electrode Assembly

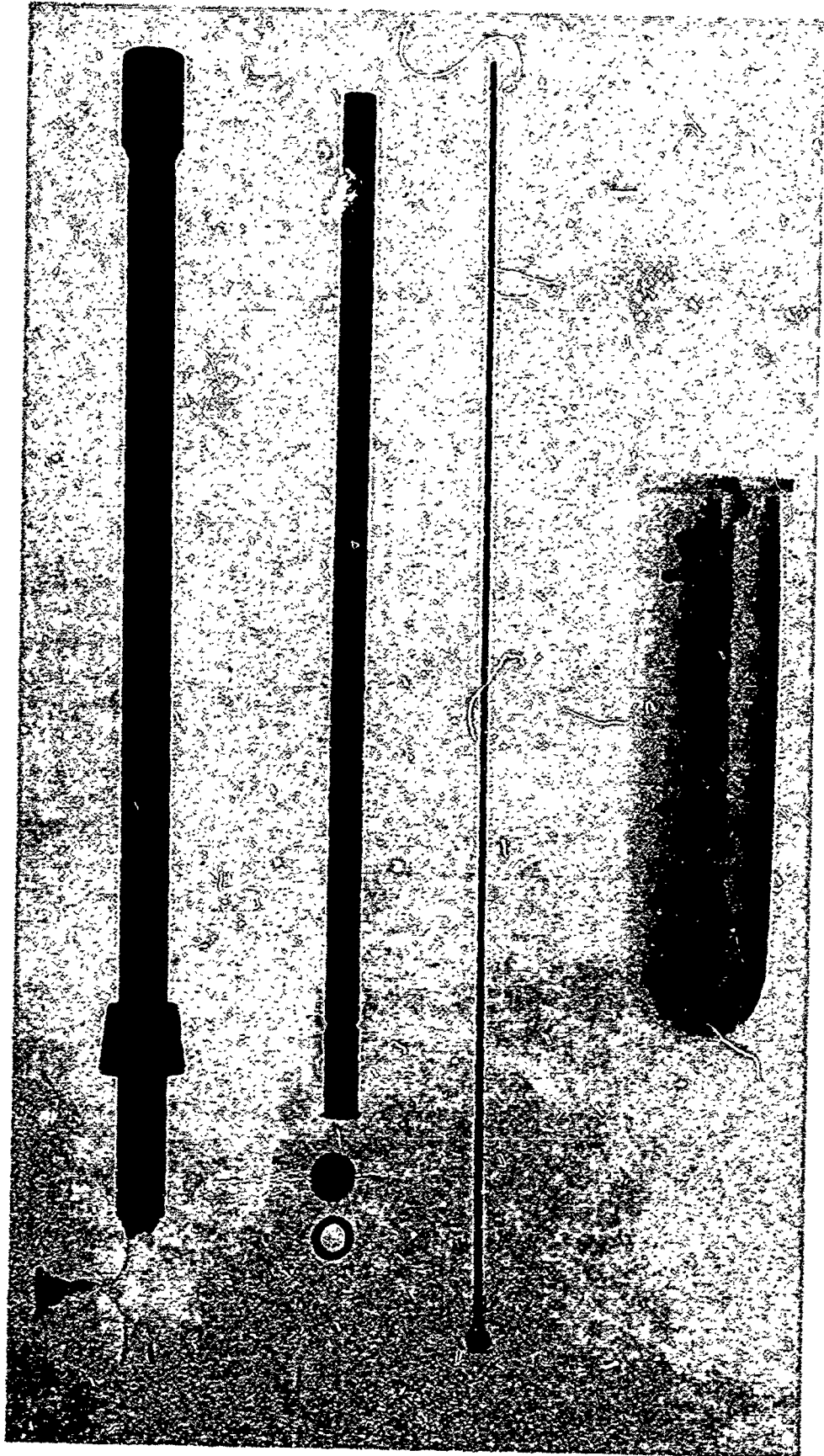

Figure 18 Photograph of "U" Cell Components

Grid Nr.	Grid Material	Tube Material	Pore Size	Thickness	Supplier Code
1	Iron	Iron	25 micron	-	18 a
2	Nickel	Nickel	25 micron	0.015 in.	19 b
3	Nickel	Iron	5 micron	0.007 in.	19 a
4	Nickel	Nickel	10 micron	0.020 in.	20
5	Nickel	Nickel	5 micron	0.007 in.	29 a

Table 3 Sodium Electrode Materials

The "U" cell runs were set up as shown in Figure 19. The sodium and chlorine electrodes were inserted in the cell as shown; a glass tube surrounding the chlorine electrode was placed at the top of the cell and both electrodes were clamped in place with the clamp shown. Silicone rubber was used to seal the top of the cell. The gas connections were all of glass tubing wherever possible; a short length of the fluorine elastomer, mentioned in the materials section, was sometimes used to connect the chlorine supply to the carbon tube. Inerting gas flow into the cell was monitored by use of the bubblers shown. The bubblers also served to regulate cell internal pressure to less than that of one-half inch concentrated sulfuric acid pressure. The electrical connections and thermocouple wires, etc., are also shown in this figure. The six runs performed used this arrangement with exceptions which will be noted.

The results of the first six runs using the "U" cell are presented in Table 4. With the exceptions of runs 2 and 5, which failed for the reasons stated, all cells showed voltages greater than 3 volts. The open-circuit voltage, after steady state conditions had been reached, was repeatedly observed to be 3.22 to 3.24 volts. The voltage of the cell is dependent upon temperature, and in these runs the uncertainty of temperature is believed to be plus or minus 25°C. It was found that the carbon electrode conducted heat at a higher rate than the nickel electrode, and for this reason, the cathode was at a lower temperature than the anode. The error in reported voltages due to this cause is less than 10 mv. The voltage of the cell was also dependent upon attaining stable conditions within the cell. The initial voltage was found to be greater than 3 volts in all cases, but a few minutes were required to reach stable voltages of 3.2 volts. This time lag is presumed to have been caused by the presence of argon in the chlorine (the chlorine supply was not turned on until the sodium was about to be introduced)

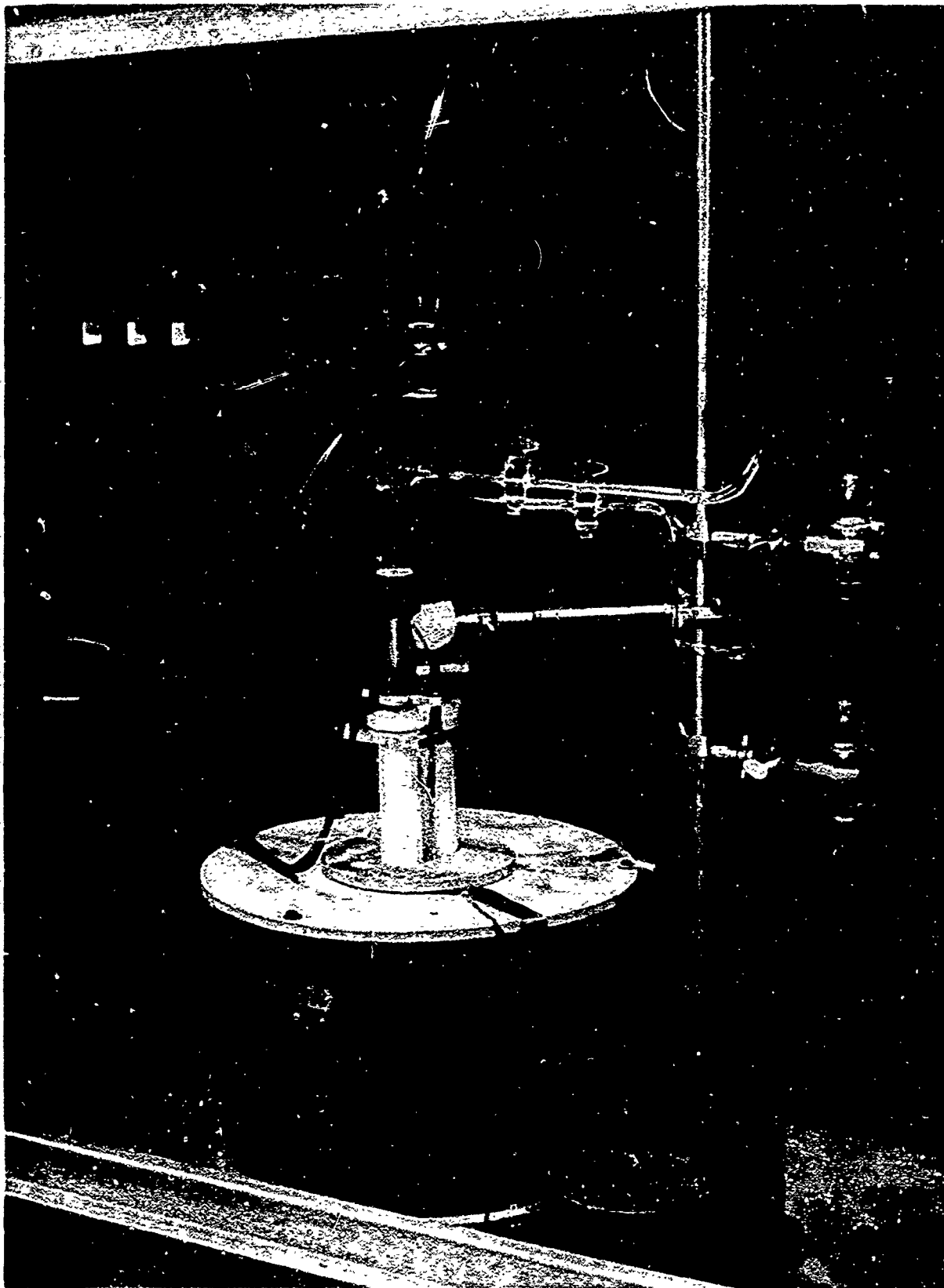

Figure 19 Photograph of "U" Cell Assembly

Run	Objective	Temperature °C	Open-Circuit Voltage Observed Volts	Remarks
1	Cell Voltage	821	3.22	No sodium electrode used. Na floated on melt Connections via iron wire.
2	Cell Voltage	825	---	Run unsuccessful due to too high a melt level; cell cracked.
3	Cell Voltage Electrode Performance	825	3.15	Studied different disks as sodium electrodes. Obtained charge-discharge data. Discharged at 22 amp/in <sup>2</sup> .
4	Cell Voltage Electrode Performance	825	3.18	Studied different disks as sodium electrodes. Obtained charge-discharge data; discharged at constant current for 28 minutes.
5	Electrode Efficiency	825	---	Run unsuccessful due to too low an electrolyte level; cell cracked.
6	Electrode Efficiency	825	3.22	Studied 5 different disks as Na electrodes; obtained coulombic efficiency data.

Table 4 Record of "U" Cell Runs

and due to the time required for the sodium to wet and thus make continuous contact with the nickel or iron electrode.

In run 1 no sodium grid was used. The sodium was allowed to float on the electrolyte. Electrical contact was made by an iron wire. This technique of making electrical contact to sodium was not satisfactory and erratic cell voltage was observed because of poor and intermittent electrical contact between the sodium and the iron. Experiments were made in the inert-atmosphere dry box to observe the relative wetting between iron and sodium and between nickel and sodium. The results showed that sodium tends to wet nickel much more quickly and completely than it wets iron. For these reasons, a large area of contact between the sodium and the grid or containing tube, preferably made of nickel, is recommended.

Run 2 failed because the electrolyte level was made too high. With this cell design, it was necessary to add sufficient salt to cover the bottom part between the two sides of the cell and to also cover the porous carbon of the chlorine electrode. On the other hand, if the salt level were too high, the top level of the salt would freeze, due to thermal gradients along the cell. If the cell temperature were then raised to melt the entire quantity of salt, as was done in Run 2, the cell was subjected to a thermal gradient of such an extent as to cause fracture. This occurred and the run was terminated.

In both run 3 and 4, a study of the effect of the sodium electrode grid material was made. These studies were made by placing sodium in the electrode, and then discharging the cell. A plot of cell voltage versus current was then made. These plots were all linear, with the exception of one test in which the supply of sodium was depleted. The cell resistance, as determined by the

slope of the plot, was the same for each electrode within experimental precision, and it was concluded that none of the grid materials chosen exhibited a limiting effect upon the performance of the sodium electrode. A typical plot is presented in Figure 20. The area of the sodium electrode was 0.196 square inches (1.27 cm<sup>2</sup>), and the maximum current drawn from any of the sodium electrodes was 4.5 amperes, although all were discharged at more than 3.5 amperes. Thus the maximum current density studied was 23 amperes/in<sup>2</sup> or 3.54 amperes/cm<sup>2</sup>.

This study of the performance of the electrodes, in which each of the electrodes of Table 3 were tested and a total of eight discharge studies was made, did not serve to distinguish between the performance of the grid materials. Although differences were noted in the slope of the discharge curves, they were not significant and were not repeatable. Thus, on the basis of these tests, electrode materials may be considered as being identical in performance up to the current densities studied. The performance was as high as was expected. The voltage of the cell was limited by the resistance of the cell electrolyte only. Electrode 5 of Table 3 was discharged for 27 minutes at a voltage of 2.5 which varied by only  $\pm 0.15$  volts during this time. After the 27 minute period, the voltage dropped to 1 volt in less than one minute as the sodium supply was depleted.

The fifth run was set up to study utilization efficiency of the sodium, but the run failed due to a low electrolyte level. The low level of the electrolyte caused the chlorine electrode to behave erratically. It was caused by a crack in the "U" cell which allowed the electrolyte to drain out.

The study of the utilization efficiency of the electrodes was repeated in the sixth run. The electrodes listed in Table 3 were employed in the study. Weight quantities of sodium were added to the electrode after reaching 825°C, and current was

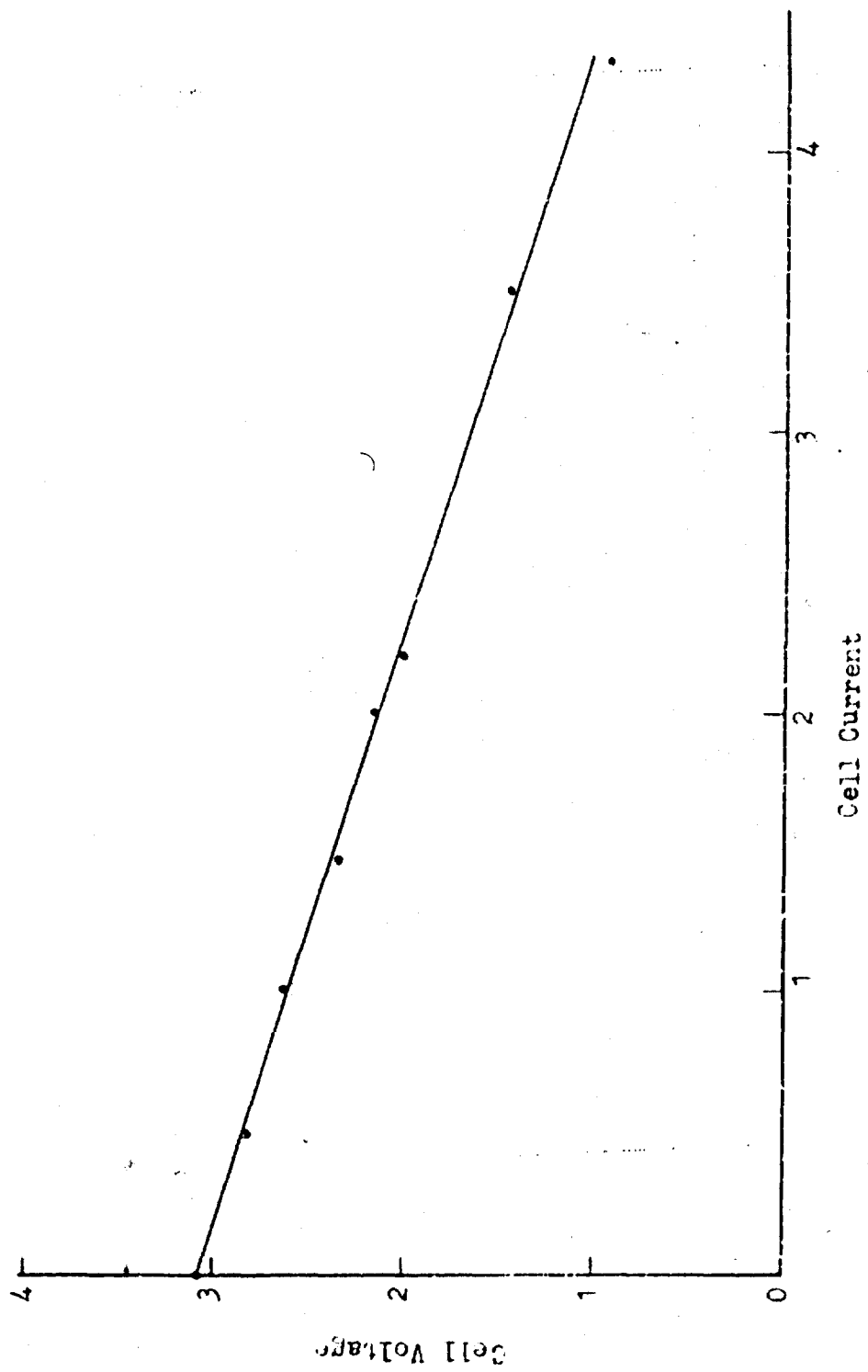

Figure 20 Variation of Na | Cl<sub>2</sub> Cell Voltage with Current

drawn at a constant rate of one ampere. The current flow was stopped when the cell voltage decreased from a voltage of about 2.8 abruptly to 2.5 volts. The results are presented in Table 5. These results indicate that smaller pore sizes reduce the rate at which sodium dissolves in the electrolyte and that iron electrodes may further reduce the sodium loss. This is consistent with expectations and with the observation that iron is less well wetted by sodium than is nickel. The relatively low efficiencies are due to a low rate of discharge and the high volume of electrolyte surrounding the sodium electrode.

These cell studies served to demonstrate the validity of the open-circuit voltage (which was 3.34 volts with a known uncertainty of -0.3 volts) employed in Part I of this report. They further served to demonstrate the reversible behavior of actual cells up to current densities of 23 amperes per square inch. Reversibility is a factor of considerable importance in the Transducer concept.

#### Other Alkali Metal | Halogen Cells

The investigation of the low-temperature portion of the transducer, i.e., the "Cold Cell", was based on sodium and chlorine as reactants because of the studies of the transducer concept made in Part I, which showed that variation of voltage with temperature was highest for the sodium-chlorine system. However, the "Cold-Cell" battery is a type of a fuel cell and other of the alkali metal | halogen combinations could be advantageous when emphasis is placed on minimum weight and maximum power for the fuel cell battery. This was pointed out in references 222 and 223 of the Part I report. On this account two experimental cells, one utilizing the  $\text{Li} + \frac{1}{2}\text{Cl}_2 \rightarrow \text{LiCl}$  reaction and the other utilizing the  $\text{Li} + \frac{1}{2}\text{I}_2 \rightarrow \text{LiI}$  were investigated.

These cells were set up with a round-bottom alumina tube as the cell case. A carbon tube plugged at the bottom with a porous

Electrode	Weight of Na grams	Time of Discharge minutes	Percent Utilization
4	1.7022	38.5	32.3
2	2.1938	44.0	28.7
3	2.1195	69.0	46.55
5	2.0593	52.0	36.11
1	2.3071	54.5	33.8

Table 5 Utilization Efficiency of Grid Materials

carbon disk was used, as usual, for the chlorine or iodine electrode. The lithium was contained in an alumina or beryllium oxide tube (Supplier Code 21) plugged at the bottom with a porous alumina disk. Both tubes were inserted into the large alumina tube containing molten LiCl or LiI at the bottom. In the case of the lithium tube the electrolyte was allowed to come up through the porous alumina plug at the bottom and molten lithium floated on the LiCl or LiI melt inside the tube. Contact to the molten lithium was made by a nickel mesh attached to a nickel wire. This arrangement prevented rapid attack of the porous alumina plug by the lithium. The effective electrode area was, then, that of the porous plug. The alumina tube was attacked by the lithium but the beryllium oxide tube was not.

The electrolytes were dried and purified, the lithium chloride in the same manner as sodium chloride. The lithium iodide was purified by passing iodine vapor through the melt, followed by filtration through activated carbon.

Inerting gases were passed over the electrolyte and the lithium. A thermocouple, jacketed in a borosilicate tube, was immersed in the electrolyte.

The lithium chlorine cell produced a voltage of 3.52 volts at 650°C. The literature value (Reference 4) for this cell is 3.53 volts at the melting point, 613°C. The cell was charged and discharged at different current levels and the cell voltage was observed. After presetting the resistor controlling cell current and then closing the circuit, the cell voltage immediately changed to a new value, dependent upon the current, and remained constant. Concentration polarization was not evident. During one period, the cell was discharged at 0.25 ampere load for 1.3 minutes, during which time the voltage changed during the load period by only 0.02 volts. This small change is interpreted as resulting from a change in working area of one or both of the electrodes rather

than being due to concentration polarization, because on opening the circuit, the voltage returned immediately to the open-circuit value. A similar check of voltage stability on open circuit for 15 minutes showed no detectable decrease in cell voltage.

The resistance of the cell under charge corresponded to 0.86 ohms and under discharge to 1.2 ohms. The difference in values is due to the difference in electrolyte path between the two operations. The distance between the two electrodes corresponds to that between the end of the Cl<sub>2</sub> electrode and the Li-electrolyte interface under discharge, and between the end of the chlorine electrode and the bottom of the Ni mesh under charge. The specific conductivity of LiCl at 614°C is 5.81 mho (Reference 3), so the observed change in resistance of 0.34 ohms corresponds to a change in path length of 0.62 cm in the 0.63 cm I.D. BeO tube. This calculated change in length is in agreement with the cell design. Since charge and discharge curves were linear and passed through the open circuit voltage value for the cell, reversible behavior with current densities limited only by the resistance of the electrolyte was confirmed. The maximum current employed was 0.6 amperes, and, taking the bore of the BeO<sub>2</sub> as the limiting electrode area, the current density corresponds to 1.95 amperes/cm<sup>2</sup> (12.5 amperes/sq.in.).

The lithium|iodine cell produced a voltage of 2.42 volts at 473°C. The literature value (Reference 4) is 2.87 volts. This cell was not studied as intensively as the chlorine electrode because the alumina tube cracked, and also because of the low cell voltage. This low voltage is believed to have been due to dissolved iodine which remained as a result of the drying treatment.

#### Voltage Change with Temperature

The concept of the Electrothermally Regenerative Transducer is based on the decrease in cell voltage with increasing temperatures. One of the objectives for this work was measurement of

voltage change. Four experiments were run to determine the  $\Delta E/\Delta T$  value.

The first three runs used the alumina "U" cell employed in the cell studies. The cell was raised to operating temperature, sodium and chlorine were fed to the electrodes and, in each case, an observed voltage of 3.2 volts was obtained. The temperature of the cell was then raised to approximately 900°C, whereupon, in each of the first three attempts, the cell cracked and the run was terminated. The suspected reasons for this mode of failure have been discussed in the Materials Section. A photograph of a fractured cell is shown in Figure 21. The crack occurred in the middle of the cell at the zone of greatest thermal gradient. In the cell shown, two cracks occurred and the cell was separated at one of these by striking a sharp blow. This region was the point of failure in the run with this type of cell.

Shown also in Figure 21 is an unexpected flaw in the cell fabrication. As shown, two saw cuts were made in the bottom of the cell and the portion of the bend removed. This disclosed that the wall separating the anode and the cathode compartments failed to extend to the bottom as far as the outside line of junction between the compartments indicated. Since the level of the electrolyte was determined by measurement of this exterior line, it is probable that the anode and cathode were not separated in this cell. Two other cells which had not been used were checked and similar flaws were observed. It is thus possible that some of the tubes employed also had a similar flaw, but the effect, if any, is not known.

Because these cells failed to withstand the temperature gradients involved, a cell was set up as described previously for the lithium/chlorine cell. A uniform cross-section circular tube was used, consequently the stresses were much more uniform. This cell was heated to 1219°C without failure.

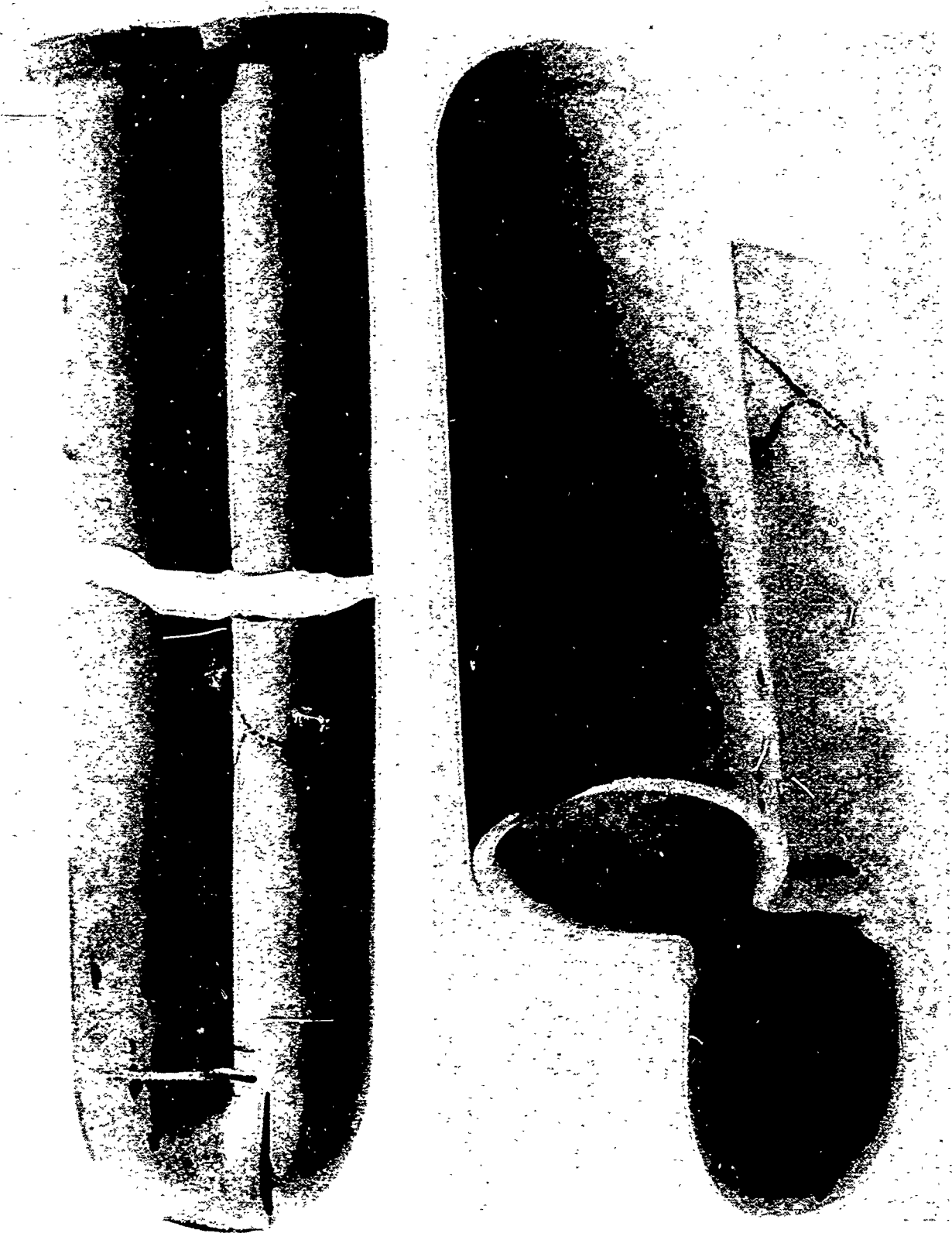

Figure 21 Photograph of Alumina "U" Cell Showing Failure Points

The experimental arrangement is shown in Figures 22 and 23. The top of the alumina cell is shown protruding from the furnace. A copper-tubing cooling coil was wound around the top of the cell. The photograph of Figure 22 was taken before the chlorine electrode had been placed in the cell. In its place was a glass apparatus which allowed the pre-purified salt to be added in small increments. This technique was used throughout most of the runs previously described. The salt, which was contained in the reservoir shown, was allowed to enter the horizontal side tube by pulling up on the steel rod, to which was attached a steel ball which acted as a valve. The ball is covered with salt in the photograph. The small quantity thus introduced to the horizontal tube was then pushed into the vertical glass tube, through which it fell into the already hot cell. The pushing was accomplished with the steel rod shown in the horizontal tube. Since the entire assembly was attached to the cell, which was filled with dry and inert gas, the salt could thus be kept dry during the addition period. It was necessary to add the salt in small increments to avoid thermal shock and also to avoid the formation of a plug of frozen salt within the cell. Rapid addition of salt was found to lead to formation of a solid plug, well above the temperature zone at which the salt was molten. When this occurred, it was necessary to raise the temperature of the cell to melt the plug, which then usually resulted in a fractured cell.

The sodium electrode is shown in Figures 22 and 23 with a similar glass side arm and push rod. This side arm served as a reservoir for small spheres of sodium metal. These were introduced, individually and when needed, by pushing the rod shown. By this technique, it was possible to replenish the supply of sodium whenever needed due to losses by solubility or volatilization. After addition of the sodium, a nickel wire, to which



Figure 22 Photograph of  $\Delta E/\Delta T$  Cell Prior to Addition of NaCl

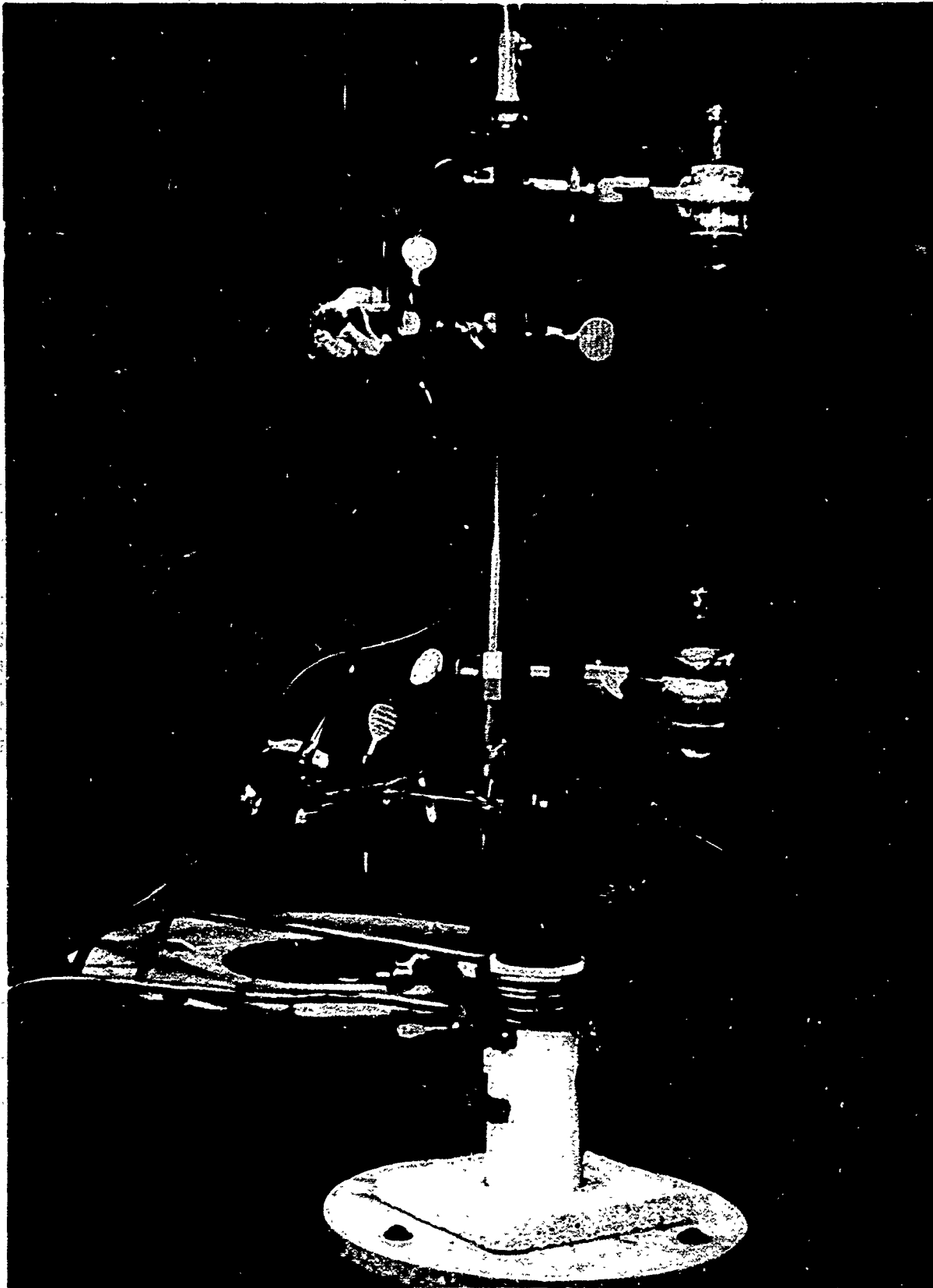

Figure 23 Photograph of  $\Delta E/\Delta T$  Cell With Chlorine Electrode

was attached a rolled cylinder of nickel sponge, was introduced down the tube to act as the sodium grid.

The entire cell was blanketed with inert gas and was tested for leaks by vacuum pumping. Provision was made to insure equal pressures between the sodium electrode tube and the cell by means of the glass manifold shown.

The chlorine electrode was placed in position after addition of the electrolyte, as shown in Figure 23. At this time, the cell was at 825°C and all the electrolyte needed had been added and was molten. The figure shows the chlorine electrode prior to being slowly (to avoid thermal shock) lowered into the melt. The chlorine feed lines were glass, and ball joints were used to make connections. The chlorine electrode was fabricated with a high-silica glass tube coaxially down its length. This tube was open to the atmosphere through a bubbler and allowed excess chlorine to escape. The pressure within the chlorine electrode was, therefore, maintained at one atmosphere. A high-silica content glass tube, closed at one end, served as a sheath for the thermocouple which was placed in the melt. In this run, a layer of 99% Al<sub>2</sub>O<sub>3</sub> sand had been placed in the bottom of the cell, sufficient in depth to cover the end of the sodium electrode, so as to avoid thermal convection, with consequent stirring, of the electrolyte.

The voltages observed in this run were recorded only after temperature equilibrium had been attained at each level of temperature. The strip-chart recorder was calibrated against a precise and accurate (0.01% error) standard, and voltages reported were read from the strip chart. The temperature-voltage data are shown in Table 6, and plotted in Figure 24.

The cell voltage became erratic as the temperature of the cell reached the boiling point of sodium. The average of the excursions showed no discontinuity, however; the erratic behavior was due to droplets of cool sodium returning to the electrode area after condensing on

Temperature °C	Cell Voltage	
	Strip-Chart Recorder Volts	Meter Volts
827	3.242	
842	3.210	
856	3.179	
861	3.158	
872	3.1475	
882	3.137	
896	3.1265	
898.5	3.116	
943		3.06
962		3.04
987		3.02
1017		2.97
1025		2.93
1057		2.88
1198		2.53
1219		2.55

Table 6 Cell Voltage Versus Temperature Data

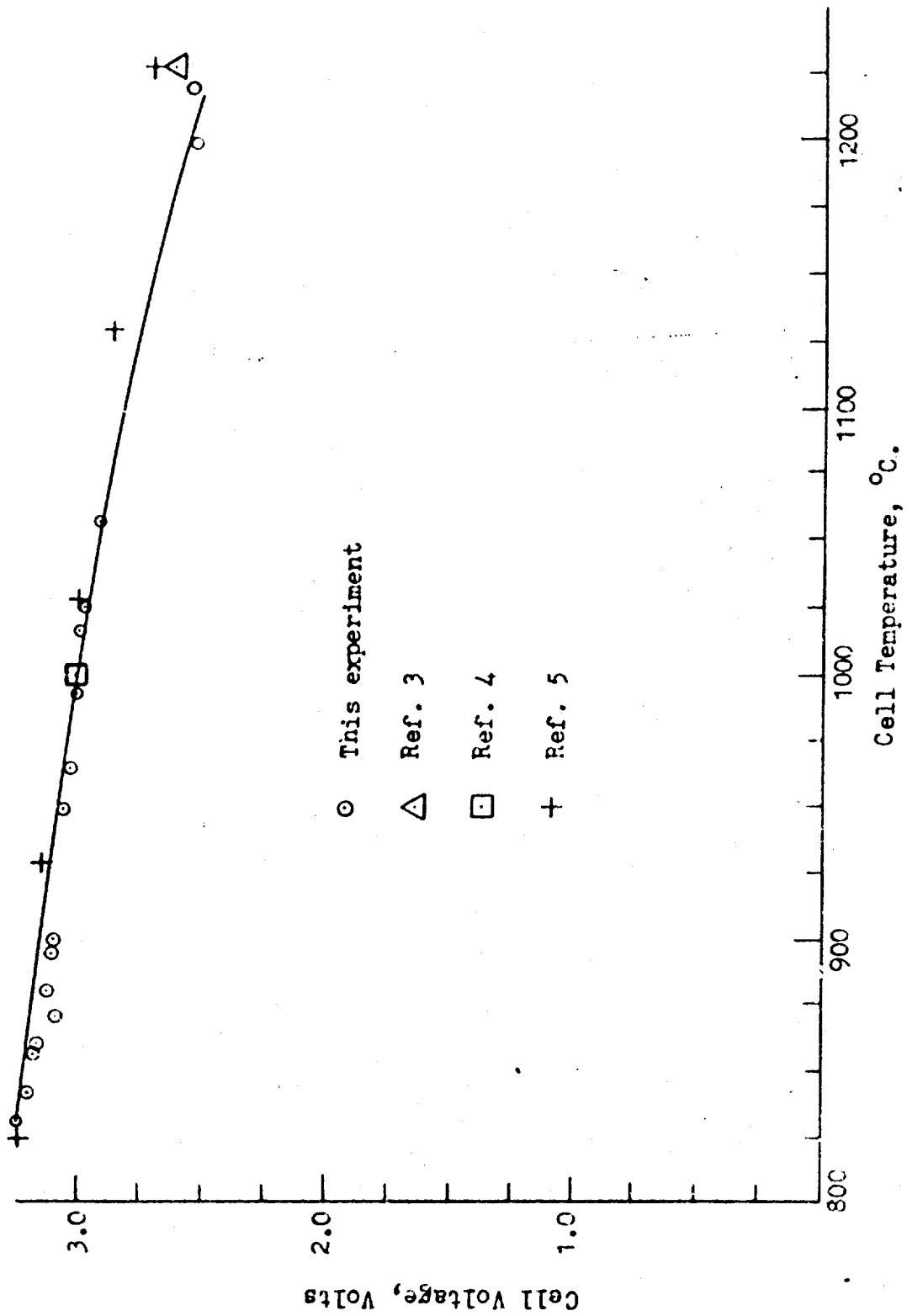

Figure 24 Plot of Cell Voltage Against Temperature

the cooler, upper portion of the sodium tube. This effect ceased after high enough temperatures (ca. 1050°C) were reached so that returning droplets re-vaporized before striking the electrode. When this effect occurred (ca. 890°C), a precise (0.5% error) galvanometer-type voltmeter was used to damp out the excursions and indicate average voltages. The data collected with this meter are noted as such in Table 6.

The degree of agreement between literature values and experimental data is also shown in Figure 24. These data tend to be lower in value than the values of the literature, and show a greater decrease in cell voltage than given by the literature, especially as temperature increases above the boiling point of sodium. The slope of the curve between 800 and 900°C. corresponds to minus 1.37 millivolts per degree Centigrade, in good agreement with theory and even at elevated temperatures the agreement is not bad. One of the basic principles of the Electrothermally Regenerative Transducer concept is demonstrated by these data.

During the acquisition of the voltage data, the opportunity to charge and discharge the cell was taken. This was done at 1017°C and 1057°C. The charge-discharge curves were linear as at 825°C, showing reversible behavior at these elevated temperatures also. The cell resistance at 1017 was 4.6 ohms and at 1057°C, it was 3.8 ohm. The decrease in resistance is typical of electrolytic conductors and the fact that the resistance is not zero supports the data obtained in Part I (pp. 107). The possibility of electronic short circuiting still exists; these data do not refute the possibility. But massive short-circuiting, resulting from high electronic conductivity, is probably absent.

The extent of sodium solubility in this experiment was shown to be low by another observation. The high-silica glass sheath around the thermocouple, which was submerged in the electrolyte,

showed a minimum of attack due to sodium. Had sodium been present to a concentration of even one weight percent, the glass would have been severely attacked. However, it should be said that the upper, cooler portions of the sodium tube could act like a cold-finger, so the actual sodium vapor pressure at the electrode was unknown.

## CELL STUDIES (PARALLEL, CLOSE-SPACED PLATES)

### Designs

In addition to constructing and testing of laboratory cells as described in the preceding sections, it was also desired to fabricate a cell of larger electrode area which would be capable of supplying higher current levels. Such a cell was to be an integrated unit, exhibiting evidence of successful engineering of the materials problems involved. Two designs were made to achieve these goals, and after discussions with suppliers, one of these was chosen for experimental investigation. Both will be discussed.

The first and more sophisticated design is presented in Figure 25. This drawing is a cross-section through the diameter of a circular cell. The drawing was used for discussion purposes only, so no dimensions will be detailed. The figure is drawn to scale for a 2 inch diameter electrode. This design represents a possible method of fabricating a cell which would exist as an integrated whole. On the left are shown two sodium feed tubes, in the center are two electrolyte feed tubes, and on the right are two chlorine feed tubes. Two tubes are necessary for laboratory purposes, one to feed the reactant, the other to remove excess and enable pressure regulation.

The salient points have been denoted with lettered call-outs and will be briefly discussed.

- A: The electrolyte feed tube. Made of niobium and diffusion bonded to the ceramic body F.
- B: Electron-beam or heliarc weld of three metal parts
- C: Diffusion bond between ceramic insulator F and niobium attachment rings
- D: Niobium attachment rings
- E: Tungsten or tungsten carbide compression ring. This ring would be used to constrict the expansion of metal parts, as was done in fabricating the ceramic-to-niobium seal reported in Part I.

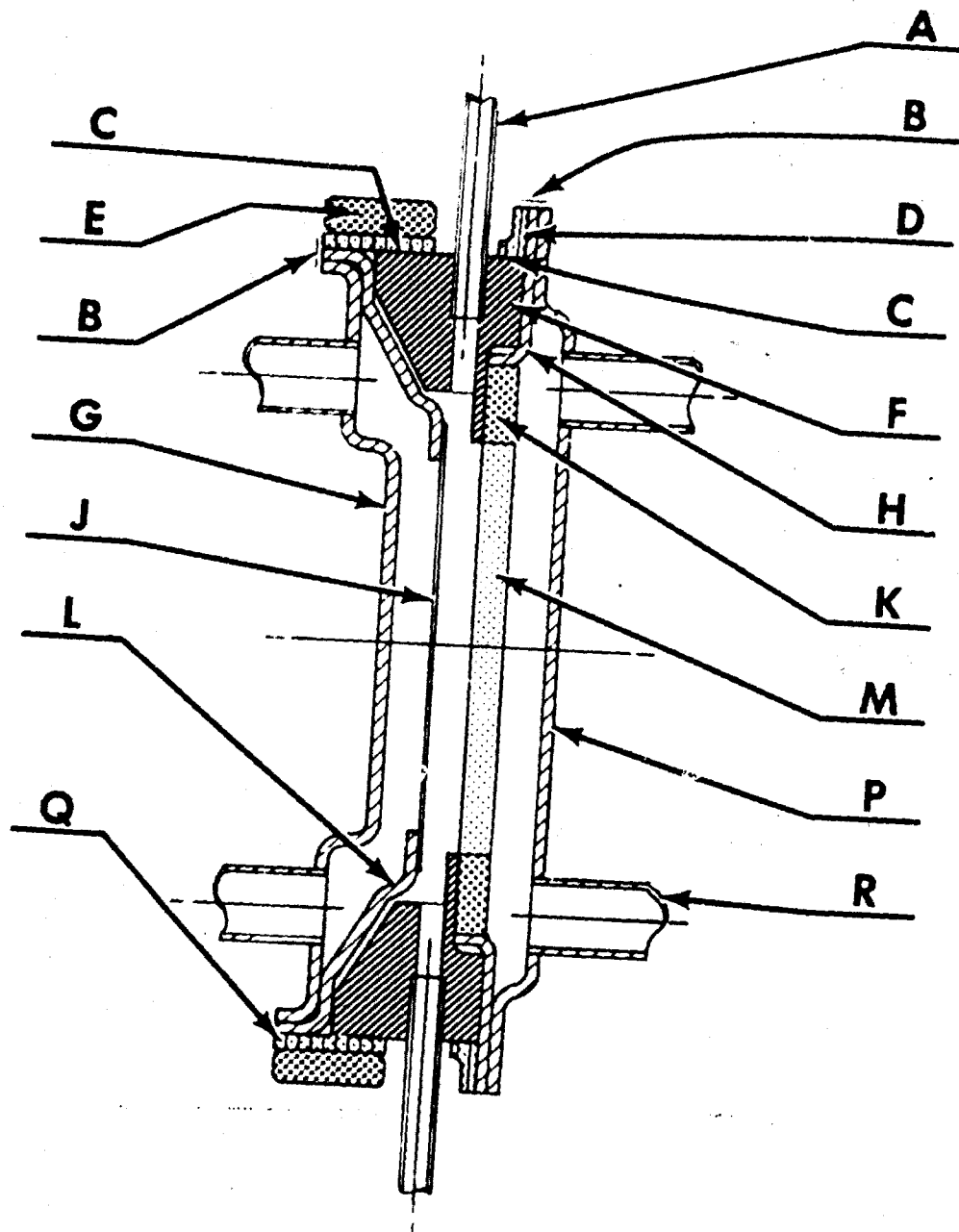

Figure 25 Cross Section of Welded Cell

- F: The aluminum oxide ceramic body used as electronic insulation between anode and cathode
- G: Sodium case end. Pure iron or tungsten
- H: Cathode ring. Tungsten ring to support the chlorine electrode. This would be carbide cemented to the carbon ring, part K
- J: Sodium electrode. Porous iron or nickel
- K: Cathode holder ring. Impervious carbon acting as retaining ring for porous carbon electrode
- L: Anode ring. Tungsten or iron supporting ring for sodium electrode
- M: Porous carbon electrode
- P: Cathode case end. Tungsten or other metal protected inside and out with ceramic glaze
- R: Chlorine feed tube. Same metals and techniques as part P.

At the time of writing, such a cell seems quite possible of fabrication. In the early phases of this study, however, the techniques required, the materials demanded, and the lack of general knowledge all acted to dissuade attempting to develop such a cell within the time period available. The design did, however, serve to stimulate discussions and redesigns, which resulted in the pressure-seal cell to be described.

The pressure-seal cell is so named because the need for welds between dissimilar materials is avoided by the use of pressure to effect a seal. Such was the concept involved in this design. A cross-section of the cell in its vice is shown in Figure 26. This is a cross-section of a circular cell having a two inch O.D. and a 1.4 inch diameter working electrode surface. The O.D. of the vice is 3.5 inches. Each part has been identified by call-outs and will be described.

- A: Vice, outer member. Made of machinable tungsten by Supplier (Code 1). Wall thickness =  $\frac{1}{4}$  inch.
- B: Aluminum oxide ring (Supplier Code 15); 2 inch O.D. and 1.4 inch I.D., 0.125 inches thick. Both sides polished, flat and parallel. These same dimensions except for thickness, and specifications apply to all of the parts C through H, and will not be repeated.

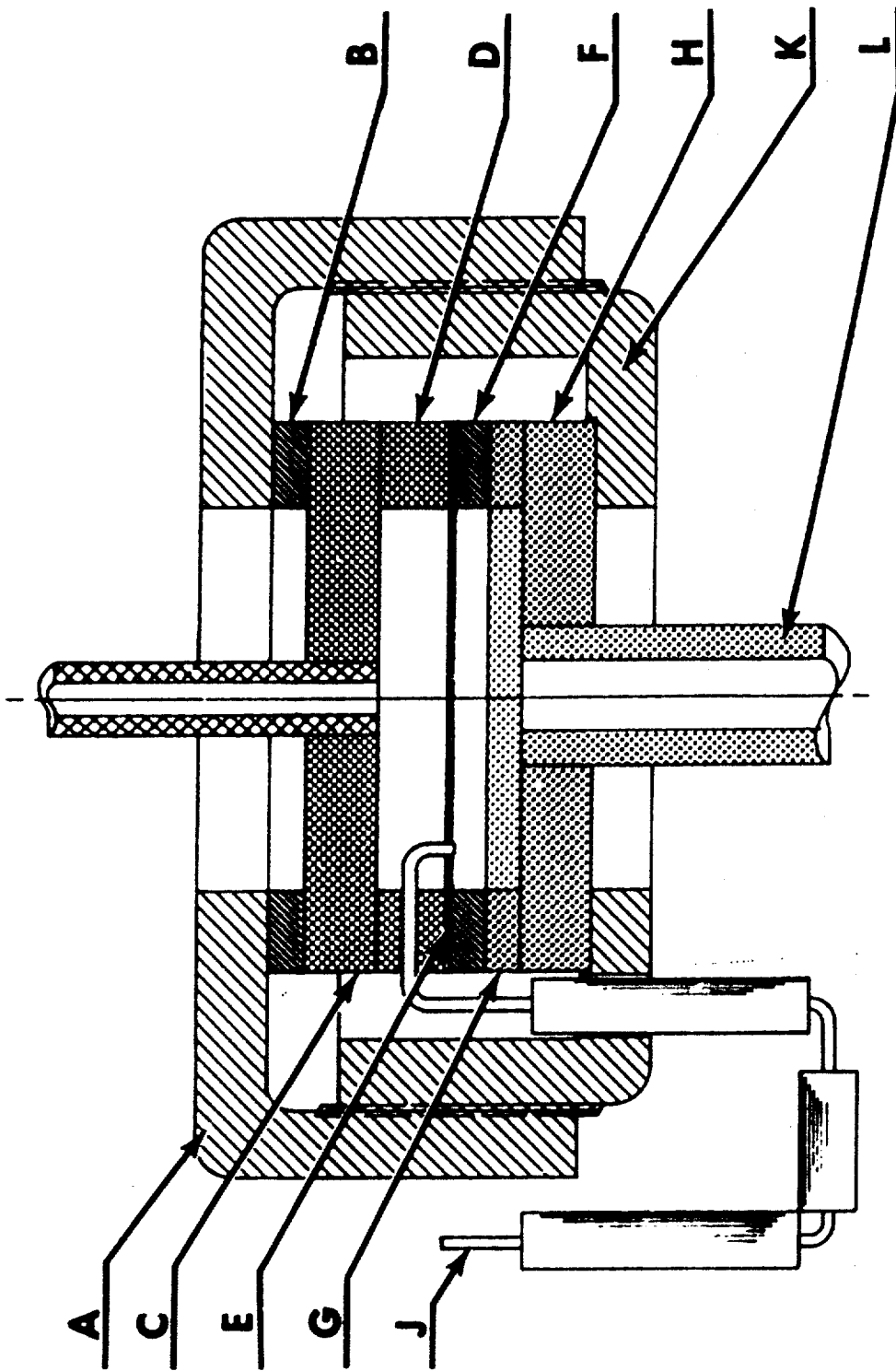

Figure 26 Cross Section of Pressure-Seal Cell

- C: Sodium electrode case end. Pure tungsten, 0.250 inch thick, with welded and brazed nickel tube (Supplier Code 1)
- D: Sodium compartment ring. Pure tungsten, 0.250 inch thick, (Supplier Code 1)
- E: Sodium electrode. Details in Figure
- F: Electrolyte Ring. Same as part B
- G: Chlorine electrode. Made of an impervious carbon ring fixed to a porous carbon insert, 0.125 inches thick. (Supplier Code 16)
- H: Chlorine electrode case end. Impervious carbon 0.250 inches thick. The 1.4 inch diameter portion of the face is grooved and channeled to provide for chlorine feed to porous carbon.
- J: Electrolyte drain tube. Hypodermic needle tubing, stainless steel, 0.059 inches O.D. Alumina insulating tubes are shown in positions required in later fixture.
- K: Vice, inner member. Same as part A.

Further description of these parts is presented in the photographs of Figures 27, 28 and 29. The details of construction of the vice are clearly shown in Figure 27. The two holes, 0.1875 inch in diameter, diametrically opposed in each vice member, are wrench attachment holes to allow the vice to be closed to a known torque. The parts shown in Figure 28 are two sodium case ends with long nickel tubes, a tungsten disk, a tungsten ring, a carbon ring, a carbon electrode, an alumina ring, a tungsten disk, and an alumina ring. These parts were to be used in either the testing of the leak rate of the components or in the cell itself. Figure 29 is a photograph of a completed sodium electrode. The outer ring is of 0.015 inch thick nickel, and to it has been welded a porous nickel disk of the same type as grid 5 in Table 3.

The pressure-seal cell concept involves the pressing together of flat cell parts with sufficient force so as to prevent leaks. This would be tested at room temperature. In order to avoid leaks at the operating temperature of 825°C, the lengths of the cell and of the vice must change by

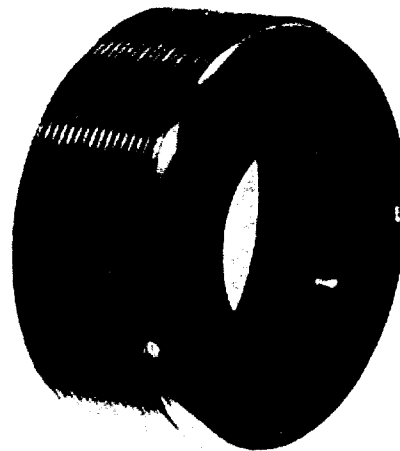

Figure 27 Photograph of Pressure-Seal Vice

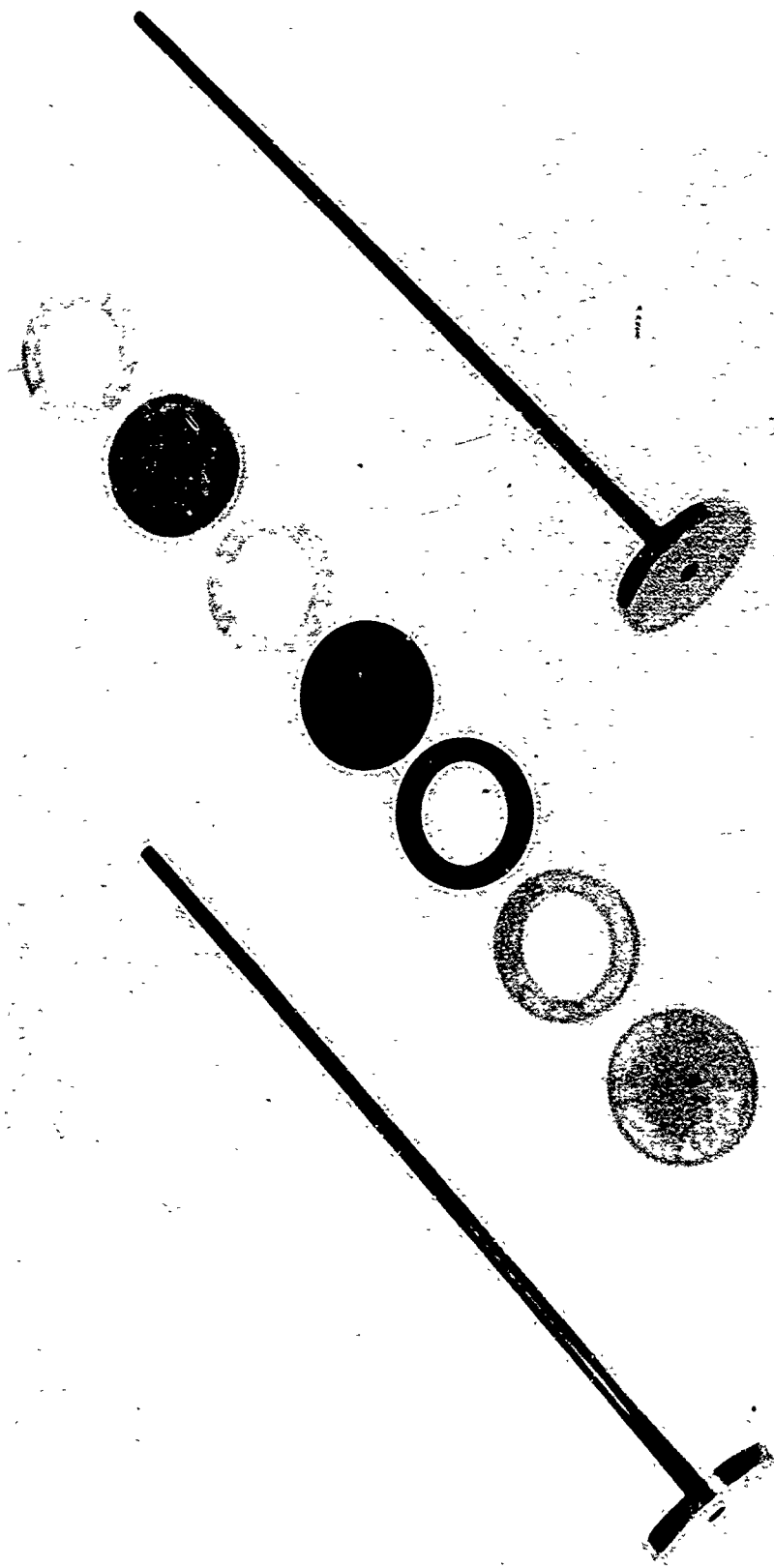

Figure 28 Photograph of Pressure-Seal Cell Components

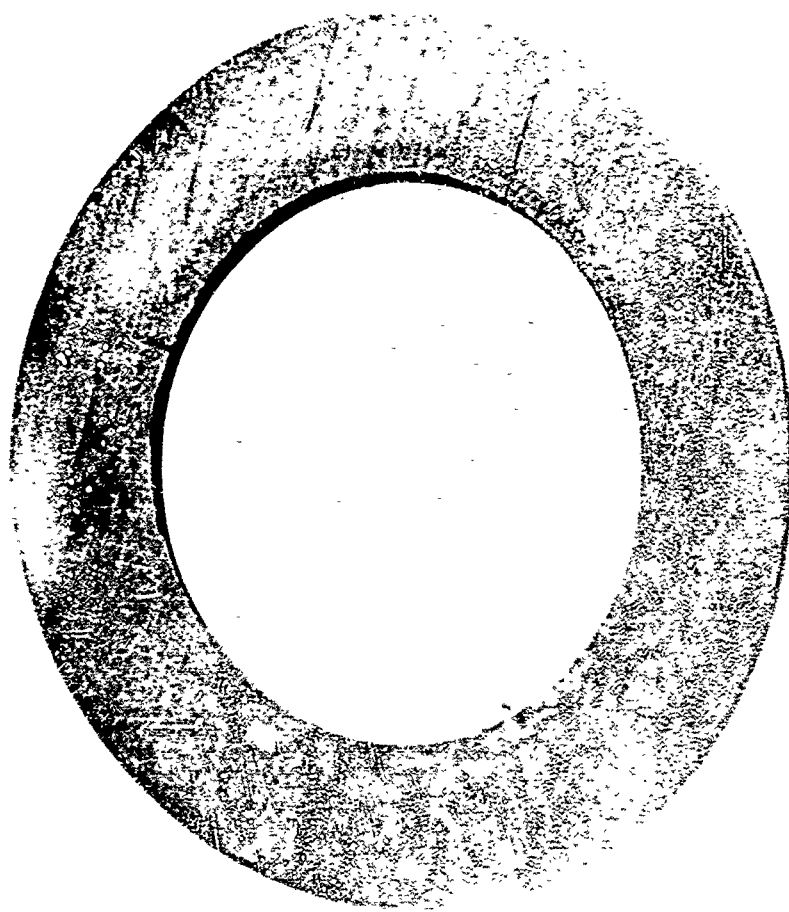

Figure 29 Photograph of Sodium Electrode for Pressure-Seal Cell

exactly the same amounts. However, because the parts are made of materials having different coefficients of expansion, it is necessary to include a means of matching the expansions.

The adjustment for differences in coefficients of expansion was first done mathematically and then tested by experiment. A unit cell consisting of a tungsten ring, a carbon ring, an alumina ring, a tungsten ring, and an alumina ring, each having the dimensions previously quoted, and the whole having a total length of 0.875 inches, was assumed. The coefficients of expansion for these materials, as used in the calculations, were:

Pure Tungsten	$4.5 \times 10^{-6} / ^\circ\text{C}$
Al <sub>2</sub> O <sub>3</sub>	4.5
Carbon	4.0
Tungsten Vice	4.81
Pure Nickel	16.3

These values were the best estimates of average coefficients of linear expansion from room temperature to 325°C that could be obtained. From these values, an average coefficient of expansion for a unit cell was calculated to be  $4.4286 \times 10^{-6} / ^\circ\text{C}$ . Using this value, it was possible to calculate the number of 0.015 inch thick nickel washers, the number of 0.250 inch thick tungsten rings, and the number of 0.125 inch thick carbon rings required to obtain a near-perfect match. A unique solution to a given assumption did not exist, of course, (v.g., it is possible to remove the carbon rings and add more nickel rings with the same end result) and the number of calculations was further increased by the boundary condition that the cell length not be increased by more than 0.5 inches by any solution.

However acceptable solutions were found and the next phase of the problem was considered. The coefficients of expansion are not known exactly, and an error resulting from an uncertainty in the coefficient could result in rupture of the cell. A calculation, based on the moduli of elasticity of the materials, showed that a cumulative error of 2.5% in the coefficients could result in a force of 11,300 pounds. Thus it was necessary to recalculate the design on the various estimates of uncertainties in coefficients.

The results of these calculations are shown in Table 7. The ratios shown correspond to ratios of assumed true coefficients of the cell to those of the vice. Thus the ratio of 109.8 percent represents the assumption that the coefficient of the cell is 9.8 percent higher than that of the vice. The assumption that the average coefficients for the vice and the cell were 20% too low would correspond to a ratio of unity, or 100 percent.

These solutions thus afforded a guide to the testing of the cell. The vice would be tightened to a leak-free condition at room temperature when assembled as shown in the 109.8 percent row. The assembly would then be heated to 825°C and the leak rate determined. If a leak occurred, the cell would be reassembled as in the 105.92 percent row and retested at 825°C. This would be continued until the leak rate remained constant or decreased by a small amount when heated. By this method, calculations of stress indicated that the cell would not be subjected to more than 2,300 pounds of force due to uncertainties in coefficients.

The correct number of spacers for leak-tight performance thus could be determined. It then would remain to assemble the cell and operate it as a fuel cell. The apparatus required for this is shown in Figure 30. The cell of Figure 26 is shown in a laboratory fixture to allow operation. The entire assembly is enclosed in a steel jacket which fits an electrical furnace. The cell is shown supported on an iron ring. The carbon electrode protrudes from the bottom of the jacket, and is electrically insulated from the jacket. The carbon tube serves to supply chlorine and also serves as an electrical lead. The cell vice, at the potential of the carbon electrode, is connected by a gold brazed copper strap, not shown, and the jacket thus serves as the positive lead of the cell. The sodium electrode, insulated from the case and the steel jacket, is the negative electrode. A nickel wire, not shown, welded to the nickel tube of the sodium electrode, serves as the negative lead. A thermocouple inserted through the steel jacket into the interior of the vice serves to allow temperature measurement. Provision for adding sodium, in the manner described in the  $\Delta E/\Delta T$  run, is shown. The entire assembly is protected by an inert atmosphere of argon introduced through the tubes shown.

<u>Ratio of Coefficients Percent</u>	<u>Number of Washers Required for Match</u>			<u>Total Cell Length inches</u>
	<u>Nickel 0.015 in</u>	<u>Carbon 0.125 in</u>	<u>Tungsten 0.250 in</u>	
109.8	0	0	1	1.125
105.92	1	1	1	1.265
104.55	1	0	1	1.140
102.8	2	1	1	1.280
101.21	2	0	1	1.155
99.93	3	1	1	1.295
98.15	3	0	1	1.170
97.27	4	1	1	1.310
95.35	4	0	1	1.185
92.76	5	0	1	1.200
90.37	6	0	1	1.215

**Table 7 Design of Coefficient Adjustments for Cell**

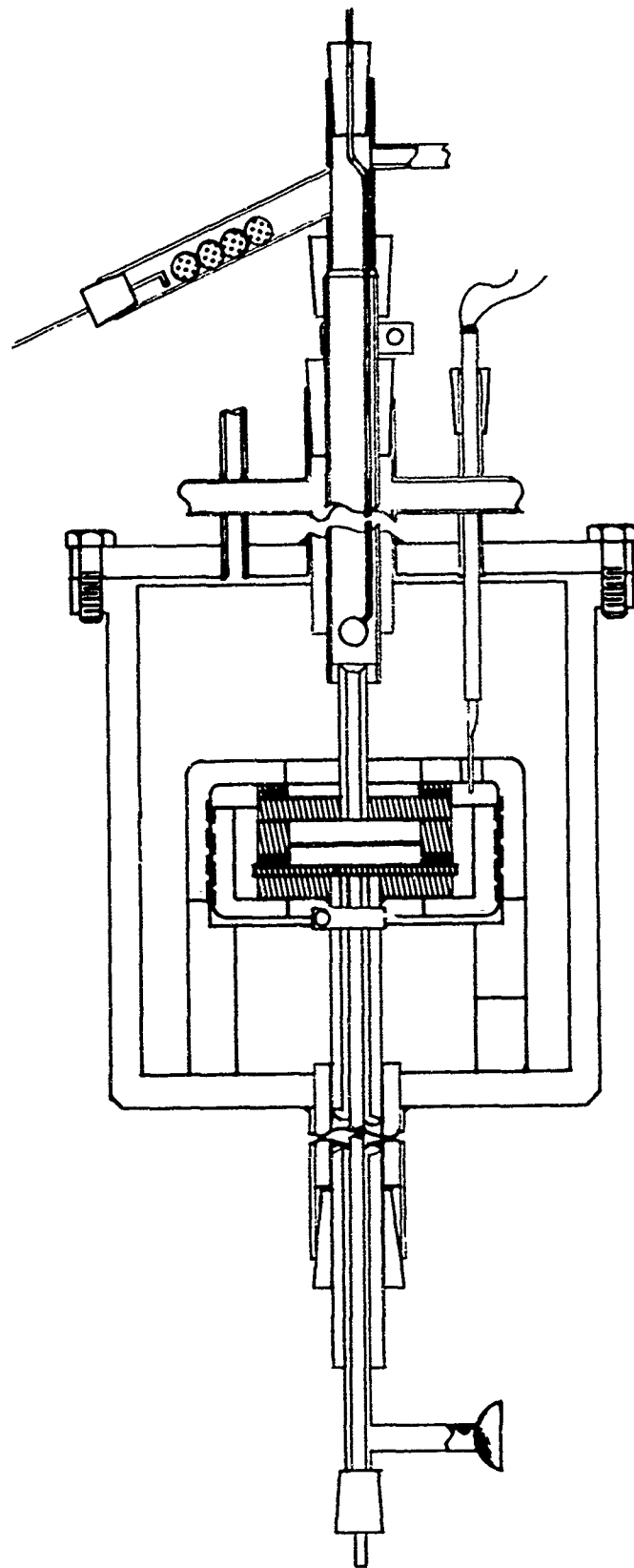

Figure 30 Experimental Set-Up of Pressure-Seal Cell

The ceramic tubes shown on the electrolyte drain tube in Figure 26 serve to insulate the tube from the cell vice and the supporting iron ring. The function of the drain tube is to remove the electrolyte as it is formed during discharge. To allow this, it is necessary for the electrolyte to rise 0.140 inches by capillary action. Calculations of the rise to be expected show that it should rise 1.14 inches, and measurements showed a rise of 1.03 inches.

The resistance of the electrolyte in the cell may be calculated to be 0.009 ohms. At maximum power, the cell itself could deliver 185 amperes. If the resistance of the carbon and nickel tubes are added, the total cell resistance becomes  $0.009 + 0.006 + 0.001$  or 0.016 ohms. At short circuit then this cell could deliver 101 amperes.

The above calculations are based on the assumption that the electrolyte could be removed quickly enough and that the chlorine could be fed fast enough to sustain such currents. A more realistic estimate of the current capability can be based on the electrode area of  $9.87 \text{ cm}^2$  or  $1.51 \text{ in}^2$ . A discharge at  $20 \text{ amperes/in}^2$ , which has been attained for both electrodes in the "U"-cell experiments, would result in a current of 30 amperes.

#### Pressure-Seal Cell Runs

Two runs were attempted with the pressure-seal cell design. Neither was satisfactory, however, the failure modes are recounted here as a guide to future work.

In run No. 1 the cell of Figure 30 was assembled containing solid electrolyte. An overnight heat-up period was programmed to bring the cell to  $700^\circ\text{C}$  by morning. During the heat-up period the furnace elements short-circuited partially and in the morning the cell was found to be at a steady temperature of  $840^\circ\text{C}$ ., which is above the melting point of the NaCl electrolyte. The addition of sodium and chlorine produced no open-circuit voltage and the cell was torn down for post-mortem.

Examination revealed the following. The electrolyte had run out of its

compartment, apparently by capillary action, through the capillary tube, consequently the cell contained little electrolyte when the reactants were admitted. The sodium, free to contact the carbon electrode, reacted with it and degraded the carbon parts. This expanded the carbon and brought it in contact with the sodium electrode, producing a short circuit. The presence of the sodium may have contributed to short-circuiting also.

Another cause of short-circuiting was also observed. The nickel tube had been welded to the tungsten plate which formed the top of the sodium chamber. This joint had cracked during previous thermal testing and the crack had been subsequently sealed with a gold-alloy braze with a melting point of  $975^{\circ}\text{C}$ . However, when the sodium metal was introduced into the sodium electrode compartment, it must have contacted the braze and dissolved it, because gold deposits were found all over the inside of the cell, as well as on the outside in the area of the braze.

In addition the stainless steel hypodermic needle tubing which was incorporated to allow overflow of electrolyte was severely corroded due to entry of chlorine into the electrolyte chamber.

The remaining parts of the cell and the vice were unaffected, and the vice was reusable after clean up.

With this experience as a guide, the cell was reassembled for the second run. Minor changes were made. The nickel tube for admission of sodium was affixed to the tungsten plate by machining threads in the tube and plate and by providing for a tight seat. The electrolyte overflow tube was omitted to avoid failure from electrolyte loss, even though it meant that the total time current could be drawn would be small. The carbon feed tube for the chlorine was fabricated as previously by cementing it to the carbon bottom plate. During cell assembly this joint separated which allowed subsequent leakage of the chlorine feed gas.

The cell was brought to operating temperature and exhibited a resistance of less than 10 ohms. (Before fusion of the electrolyte the resistance was more than 10,000 ohms). During heating the cell displayed a

voltage of about 20 mv. which is assumed to be the thermopotential of the nickel-carbon thermocouple provided by the electrode components.

When the reactants were admitted, the cell voltage rose to 2.8 volts. A load was applied and at 2 amperes the cell voltage was measured to be 2.0 volts and it was decreasing rapidly. When the voltage reached 1 volt the run was stopped and the cell cooled for examination.

Inspection showed the carbon had been attacked again causing it to crack thus providing an electrolyte leak. This situation is conjectured to have occurred due to the leak at the carbon tube-to-back plate junction. Thus, the argon gas present in the chlorine electrode chamber and in the porous carbon electrode may not have been swept out by the chlorine. If so, insufficient chlorine may have been present in the electrode to prevent attack to the electrode by sodium dissolved in the electrolyte.

The sodium grid was unattacked and all other parts of the cell and the vice were reusable. Further study of this design would have included fabrication of a mechanically strong, leak-proof seal of the carbon tube to the carbon back-up plate. Arrival of the end of the contract period prevented additional work; however, the pressure-seal design is probably capable of providing a suitable test bed for studying compact cell design performance until suitable fabrication techniques for an integrated cell can be worked out.

TECHNICAL REPORT DISTRIBUTION (CONTINUED)

Commanding Officer Diamond Ordnance Fuze Laboratories Washington 25, D.C. Attn: Technical Reference Section	(1)
Commander Armed Services Technical Information Agency Arlington Hall Station Arlington 12, Virginia Attn: TIPCA	(10)
Commanding Officer Rock Island Arsenal Rock Island, Illinois Attn: ORDOW-TX	(1)
Commanding Officer Engineering Research & Development Laboratories Fort Belvoir, Virginia Attn: Radiation Laboratories	(1)
Signal Corps Liaison Office	(1)
Ordnance Materials Research Office Watertown Arsenal Watertown 72, Massachusetts Attn: ORDBE-Z	(1)
Commanding Officer Frankford Arsenal Bridesburg Station Philadelphia 37, Pennsylvania	(1)
Commanding General HQ, U.S. Army Materiel Command Attn: AMCOR(TW)	(1)
Attn: AMCOR (TB) Department of the Army Washington 25, D. C.	(1)
Delco-Remy Division General Motors Corporation Anderson, Indiana Attn: Dr. J. J. Lander	(5)
Mr. H. L. Hartzell	(1)
Mr. L. R. Hetzler	(1)
Mr. Rine Kruger	(1)

<p>AD _____ ACCESSION NO _____</p> <p>Delco-Remy Division of General Motors Corporation, Anderson, Indiana</p> <p>FEASIBILITY STUDIES OF THE ELECTROTHERMALLY REGENERATIVE TRANSDUCER, PART II - Robert D. Weaver</p> <p>Final Report, 30 June 1964, 89 pp 30 illus 7 tables (Contract DA33-008-ORD-2335(T) DA Proj 518-01-001 ORD Proj 5521.12.27540.31 Unclassified Report</p> <p>Laboratory cells, utilizing sodium and chlorine as re- actants, have been assembled and tested. They were shown to produce theoretical voltages over a temperature range of 8.5°C. to 1219°C. and were capable of being reversibly dis- charged at more than 20 amperes per square inch of electrode area. Studies of advanced designs cells were made.</p> <p>This work is evaluated in terms of practical feasibility of the Electrothermally Regenerative Transducer and a fuel cell battery based on the alkali metals and the halogens as reactants. Recommendations for future work are made.</p> <p>This report is the second part of the Final Report. Part I, dated 30 March 1963, was performed under Contract DA33-008-ORD-2335.</p>	<p>UNCLASSIFIED</p> <p>1) Electrothermal Transducers 2) Power Conversion 3) Contract DA33-008-ORD-2335(T)</p>
<p>AD _____ ACCESSION NO _____</p> <p>Delco-Remy Division of General Motors Corporation, Anderson, Indiana</p> <p>FEASIBILITY STUDIES OF THE ELECTROTHERMALLY REGENERATIVE TRANSDUCER, PART II - Robert D. Weaver</p> <p>Final Report, 30 June 1964, 89 pp 30 illus 7 tables (Contract DA33-008-ORD-2335(T) DA Proj 518-01-001 ORD Proj 5521.12.27540.31 Unclassified Report</p> <p>Laboratory cells, utilizing sodium and chlorine as re- actants, have been assembled and tested. They were shown to produce theoretical voltages over a temperature range of 8.5°C. to 1219°C. and were capable of being reversibly dis- charged at more than 20 amperes per square inch of electrode area. Studies of advanced designs cells were made.</p> <p>This work is evaluated in terms of practical feasibility of the Electrothermally Regenerative Transducer and a fuel cell battery based on the alkali metals and the halogens as reactants. Recommendations for future work are made.</p> <p>This report is the second part of the Final Report. Part I, dated 30 March 1963, was performed under Contract DA33-008-ORD-2335.</p>	<p>UNCLASSIFIED</p> <p>1) Electrothermal Transducers 2) Power Conversion 3) Contract DA33-008-ORD-2335(T)</p>
<p>AD _____ ACCESSION NO _____</p> <p>Delco-Remy Division of General Motors Corporation, Anderson, Indiana</p> <p>FEASIBILITY STUDIES OF THE ELECTROTHERMALLY REGENERATIVE TRANSDUCER, PART II - Robert D. Weaver</p> <p>Final Report, 30 June 1964, 87 pp 30 illus 7 tables (Contract DA33-008-ORD-2335(T) DA Proj 518-01-001 ORD Proj 5521.12.27540.31 Unclassified Report</p> <p>Laboratory cells, utilizing sodium and chlorine as re- actants, have been assembled and tested. They were shown to produce theoretical voltages over a temperature range of 8.5°C. to 1219°C. and were capable of being reversibly dis- charged at more than 20 amperes per square inch of electrode area. Studies of advanced designs cells were made.</p> <p>This work is evaluated in terms of practical feasibility of the Electrothermally Regenerative Transducer and a fuel cell battery based on the alkali metals and the halogens as reactants. Recommendations for future work are made.</p> <p>This report is the second part of the Final Report. Part I, dated 30 March 1963, was performed under Contract DA33-008-ORD-2335.</p>	<p>UNCLASSIFIED</p> <p>1) Electrothermal Transducers 2) Power Conversion 3) Contract DA33-008-ORD-2335(T)</p>
<p>AD _____ ACCESSION NO _____</p> <p>Delco-Remy Division of General Motors Corporation, Anderson, Indiana</p> <p>FEASIBILITY STUDIES OF THE ELECTROTHERMALLY REGENERATIVE TRANSDUCER, PART II - Robert D. Weaver</p> <p>Final Report, 30 June 1964, 89 pp 30 illus 7 tables (Contract DA33-008-ORD-2335(T) DA Proj 518-01-001 ORD Proj 5521.12.27540.31 Unclassified Report</p> <p>Laboratory cells, utilizing sodium and chlorine as re- actants, have been assembled and tested. They were shown to produce theoretical voltages over a temperature range of 8.5°C. to 1219°C. and were capable of being reversibly dis- charged at more than 20 amperes per square inch of electrode area. Studies of advanced designs cells were made.</p> <p>This work is evaluated in terms of practical feasibility of the Electrothermally Regenerative Transducer and a fuel cell battery based on the alkali metals and the halogens as reactants. Recommendations for future work are made.</p> <p>This report is the second part of the Final Report. Part I, dated 30 March 1963, was performed under Contract DA33-008-ORD-2335.</p>	<p>UNCLASSIFIED</p> <p>1) Electrothermal Transducers 2) Power Conversion 3) Contract DA33-008-ORD-2335(T)</p>
<p>AD _____ ACCESSION NO _____</p> <p>Delco-Remy Division of General Motors Corporation, Anderson, Indiana</p> <p>FEASIBILITY STUDIES OF THE ELECTROTHERMALLY REGENERATIVE TRANSDUCER, PART II - Robert D. Weaver</p> <p>Final Report, 30 June 1964, 87 pp 30 illus 7 tables (Contract DA33-008-ORD-2335(T) DA Proj 518-01-001 ORD Proj 5521.12.27540.31 Unclassified Report</p> <p>Laboratory cells, utilizing sodium and chlorine as re- actants, have been assembled and tested. They were shown to produce theoretical voltages over a temperature range of 8.5°C. to 1219°C. and were capable of being reversibly dis- charged at more than 20 amperes per square inch of electrode area. Studies of advanced designs cells were made.</p> <p>This work is evaluated in terms of practical feasibility of the Electrothermally Regenerative Transducer and a fuel cell battery based on the alkali metals and the halogens as reactants. Recommendations for future work are made.</p> <p>This report is the second part of the Final Report. Part I, dated 30 March 1963, was performed under Contract DA33-008-ORD-2335.</p>	<p>UNCLASSIFIED</p> <p>1) Electrothermal Transducers 2) Power Conversion 3) Contract DA33-008-ORD-2335(T)</p>
<p>AD _____ ACCESSION NO _____</p> <p>Delco-Remy Division of General Motors Corporation, Anderson, Indiana</p> <p>FEASIBILITY STUDIES OF THE ELECTROTHERMALLY REGENERATIVE TRANSDUCER, PART II - Robert D. Weaver</p> <p>Final Report, 30 June 1964, 87 pp 30 illus 7 tables (Contract DA33-008-ORD-2335(T) DA Proj 518-01-001 ORD Proj 5521.12.27540.31 Unclassified Report</p> <p>Laboratory cells, utilizing sodium and chlorine as re- actants, have been assembled and tested. They were shown to produce theoretical voltages over a temperature range of 8.5°C. to 1219°C. and were capable of being reversibly dis- charged at more than 20 amperes per square inch of electrode area. Studies of advanced designs cells were made.</p> <p>This work is evaluated in terms of practical feasibility of the Electrothermally Regenerative Transducer and a fuel cell battery based on the alkali metals and the halogens as reactants. Recommendations for future work are made.</p> <p>This report is the second part of the Final Report. Part I, dated 30 March 1963, was performed under Contract DA33-008-ORD-2335.</p>	<p>UNCLASSIFIED</p> <p>1) Electrothermal Transducers 2) Power Conversion 3) Contract DA33-008-ORD-2335(T)</p>