

AD 608718

NRL Report 6173

The NRL Air Resistance Meter, Model II

K. D. LAWRENCE AND J. A. YOUNG

*Protective Chemistry Branch
Chemistry Division*

and

R. H. COLLINS

Engineering Services Division

COPY	2	OF	3	ms
HARD COPY	\$ 6.50			
MICROFICHE	\$ 6.50			

Sp

October 30, 1964

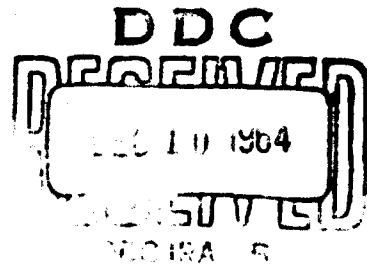

ARCHIVE COPY

U.S. NAVAL RESEARCH LABORATORY
Washington, D.C.

Best Available Copy

ABSTRACT

The resistance to airflow is one of the basic characteristics of aerosol filtration materials. With the relatively recent study and development of new low-resistance filters and canisters, there was a need for an improved air resistance meter. In response to this need, NRL designed a new air resistance meter which provides accuracy, versatility, and rapidity of measurement. It utilizes a system of three parallel air lines, each designed to accommodate a specific range of airflows and each with its own separate control valve. These serve to furnish a more accurately calibrated span of airflows up to 100 liters/minute. The instrument is mounted on a table making a convenient semiportable laboratory device.

This device has a pneumatically operated chuck to hold the filter sample. The chuck provides uniformity and rapidity of operation and is designed to allow inserts and other alterations to be made easily.

The new air resistance meter can be used in conjunction with other equipment to measure airflow resistance and aerosol penetration simultaneously.

PROBLEM STATUS

This is a final report on this phase of the problem; work on other phases of the problem is continuing.

AUTHORIZATION

NRL Problem C05-17
RR 001-01-43-4701

Manuscript submitted September 8, 1964.

THE NRL AIR RESISTANCE METER, MODEL II

INTRODUCTION

Equipment and techniques for measuring the resistance to airflow of aerosol filter materials and canisters have been utilized at this Laboratory since 1941 (1). The method involves drawing air at a known rate of flow through a canister or through a disk of filter paper masked to a known area. A manometer attached across the canister or paper gives the pressure differential or air resistance in millimeters of water.

Although the Air Resistance Meter, Model I is still useable, the new low-resistance filters developed by this Laboratory have led to a need for an improved machine. The older unit is satisfactory for air resistances of about 100 mm of water but accuracy is poor at lower resistances. Another drawback is that the canister holder was designed for the old B-2 canister (2) which has been replaced by the C-2 canister (3) of an entirely different design. The operation of the paper holder is also unsatisfactory. When the holding chuck is set for single sheets of filter paper, readjustment is required for measuring resistances of fiber pads. Moreover, sealing pressure exerted on samples cannot be standardized and varies with each operator.

An air resistance instrument was required which would provide not only a series of standard airflows but also any desired airflow up to 100 liters/min. A holding chuck was needed which would accommodate the new types of Navy canisters as well as filter papers and fiber pads. A new instrument (Air Resistance Meter, Model II) has been developed by NRL to satisfy these needs (Figs. 1 and 2). This instrument fulfills all of these requirements and can be modified quickly and easily to accommodate a large variety of experimental samples. One of the most useful features of the new meter is the ability to measure air resistance and smoke penetration simultaneously at the lower flow rates.

DESIGN CHARACTERISTICS

While the basic principles of the Model I are still used in the Model II meter, a number of improvements have been made. The original, single system with its orifice and control valve has been replaced with three parallel air systems. The manually operated clamping chuck has been replaced with a precision, timesaving pneumatic chuck, and the new equipment has been mounted to provide a convenient, semiportable device.

One of the principal features of the new resistance meter is its three parallel air systems, each with its own orifice, control valve, and flow manometer (Fig. 3). Air is drawn through the sample held in the clamping chuck and is routed through one of three paths. A different sized orifice in each system provides a low, medium, or high range of airflow. The low range provides airflows to 17 liters/min, the medium range provides flows to 45 liters/min, and the high range to 100 liters/min. In actual practice, however, flow ranges are generally limited to 13 to 18, 20 to 50, and 40 to 100 liters/min respectively to take full advantage of the steep portions of the calibration curves and to provide maximum sensitivity and accuracy.

The three orifice plates have openings of 0.125, 0.194, and 0.270 inch with their arrangement in the holders shown in Fig. 4. The holders have been designed so that they may be easily disconnected for cleaning or replacement of the orifice plates. If desired,

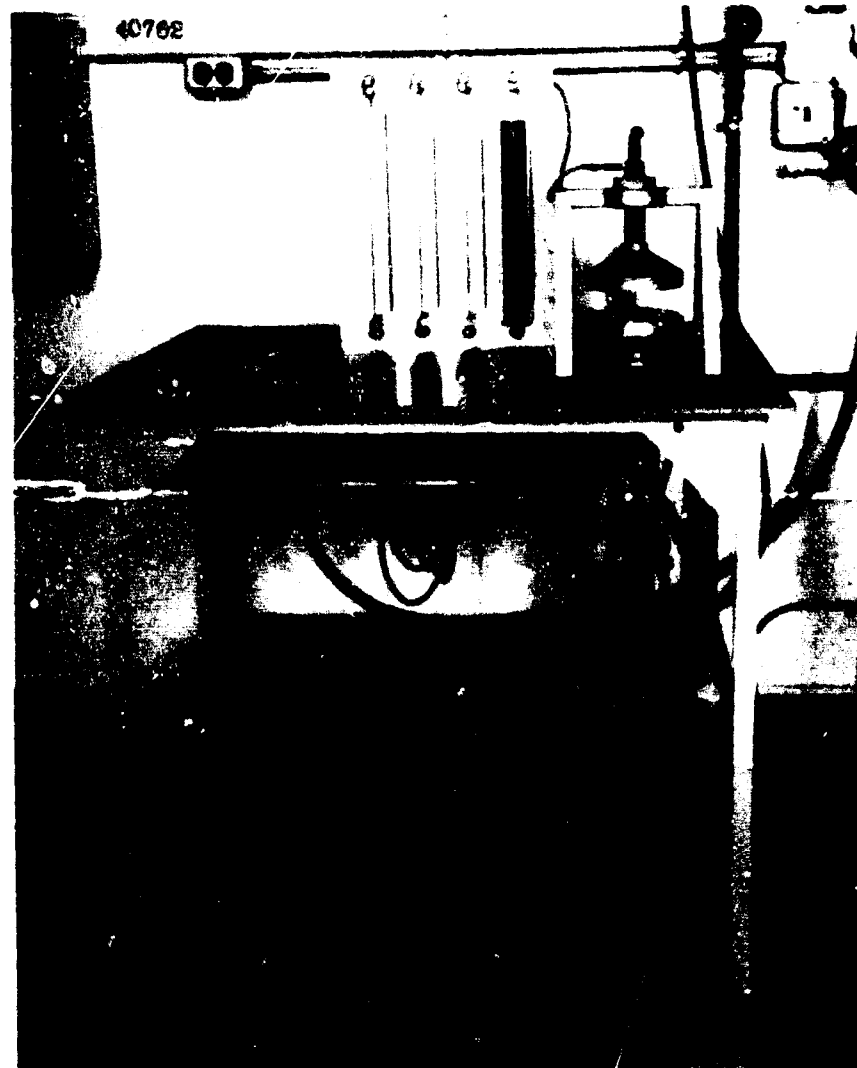

Fig. 1 - Front view of the NRL Air Resistance Meter, Model II

larger orifices could be used to increase the flow capacity of the equipment. Taps for the flow manometer are located on each side of the orifice plate at a distance of one inch from the orifice. This arrangement of pressure taps is designated "flange tap." Since flange-tap positions are independent of orifice diameter or the pipe diameter, different orifices could be inserted to provide high airflow rates with minimum change in the system.

The pneumatic holding chuck is another prominent feature of the improved equipment (Fig. 5). It consists of two conical jaws; the top jaw is held rigidly while the lower is attached to a movable air piston. The movable jaw is controlled by a 6-volt solenoid in the air line. A three-position switch (up, off, down as seen in Fig. 3) controls the action of the solenoid. By means of flow and pressure regulators in the air line, closure rate and clamping pressure may be adjusted over a wide range. Normally, air pressure of 20 psig is used which is adequate to effect sealing without excessive pressure on the sample material. The actual clamping area is reduced by use of mating ridges on the clamping jaws. The flow regulator is set to give a satisfactory closure rate of the clamping chuck.

Although the upper jaw is held rigidly, it may be raised or lowered several inches by rotating the screw thread and retightening the clamping nut. This may be done to

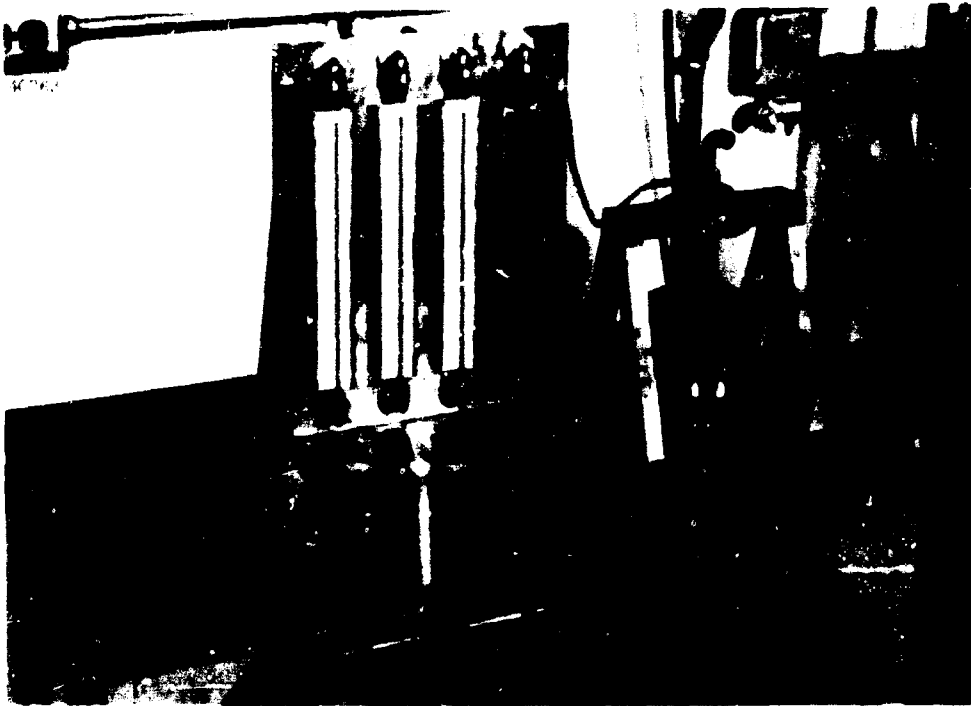

Fig. 2 - Top view of apparatus showing the clamping chuck and controls

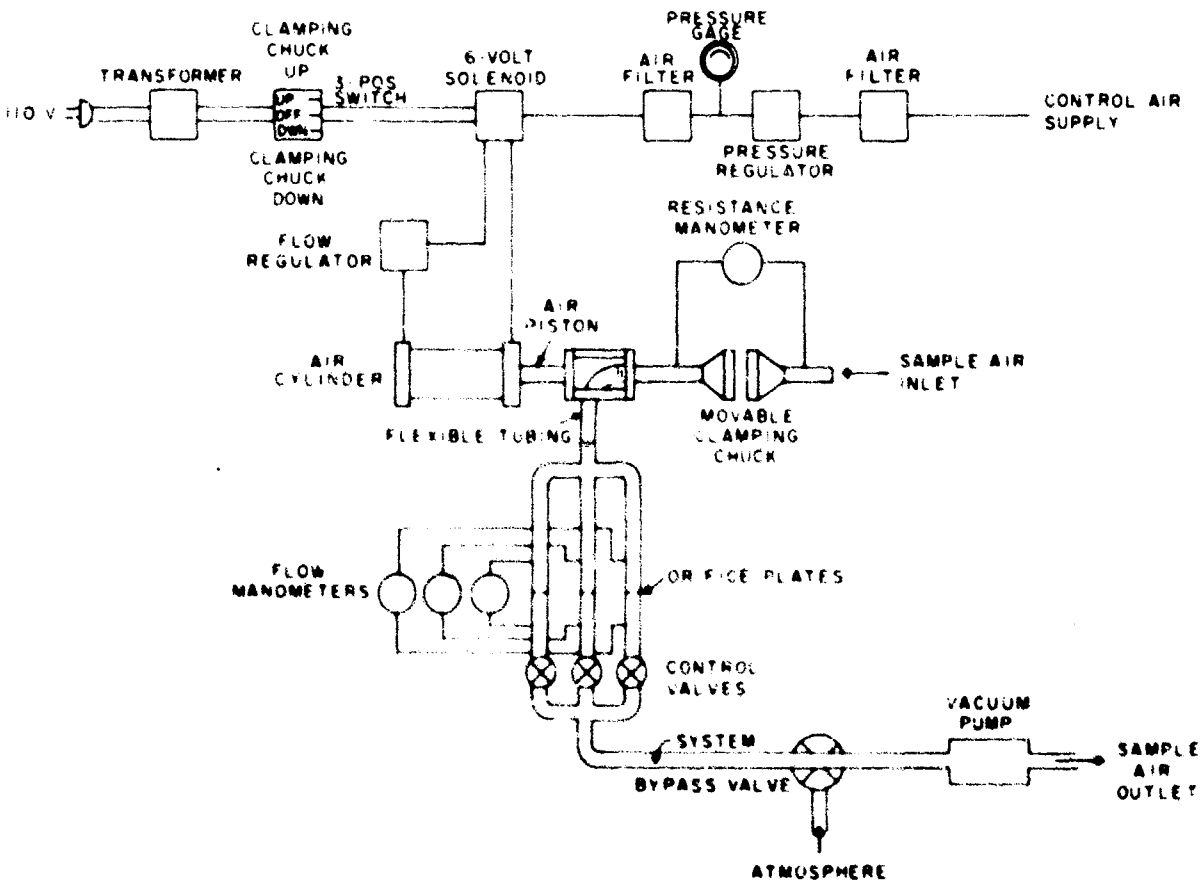

Fig. 3 - Flow diagram of the Air Resistance Meter, Model II

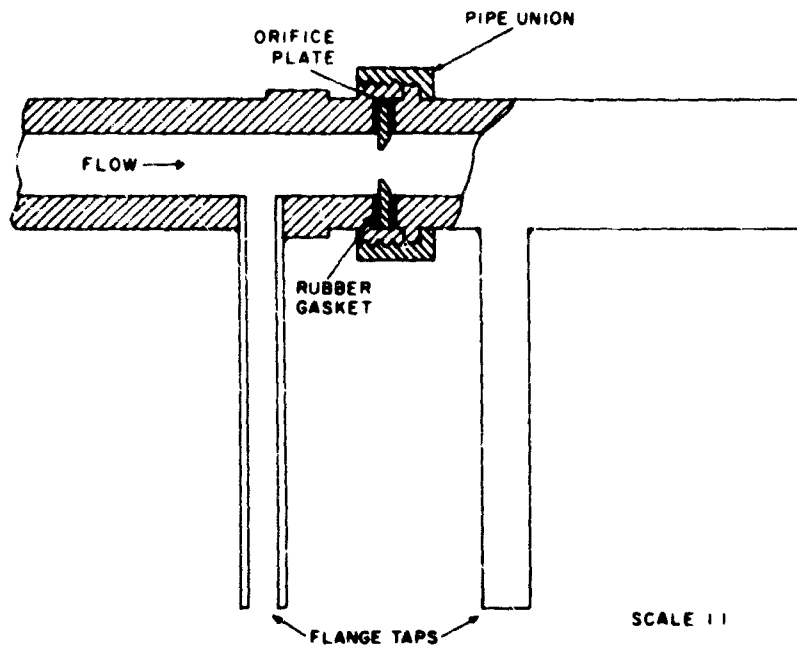

Fig. 4 - Diagram of orifice plate, holder, and flange taps

accommodate special inserts or canisters. The shaft of the lower chuck passes through a bushing which keeps all movement in a vertical line. Vertical alignment is such that a paper as thin as cigarette paper (1.5 mil) can be clamped and held firmly between the jaws. The large screen of the lower jaw acts as a support for the filter material being checked. A second screen acts as a lint trap to prevent loose fibers from entering the system. Both screens may be removed and cleaned readily.

The new clamping chuck has other advantages over the older one. It is much simpler to operate than the manual chuck in that filter papers or fiber mats of various thicknesses may be run consecutively without changing the chuck in any way. Pressure applied to the filter material is not only uniform but also measurable and controllable.

Oil with a specific gravity of 0.834 is used in all the manometers. By means of the proper scale, however, the resistance manometer reads directly in millimeters of water.

CALIBRATION

The calibration of the resistance meter is accomplished by use of a wet test meter of one cfm capacity. Each orifice is placed in series with the wet test meter and the pressure drop across the orifice determined as a function of air flow rate. This procedure is repeated for at least 12 values of airflow within the desired range with triplicate measurements taken at each setting. Calibration curves are then plotted for each of the three orifice plates. From these curves, "standard" flow rates of 16, 32, 42.5, and 85 liters/min are marked on the flow manometer scales.

The calibration of the resistance meter is accomplished without samples in the chuck. One source of error in the calibration is that the absolute pressure upstream of the orifice plate depends on the resistance of the filter material being measured. Since the maximum filter resistance which can be measured with the meter is 250 mm of water and since the

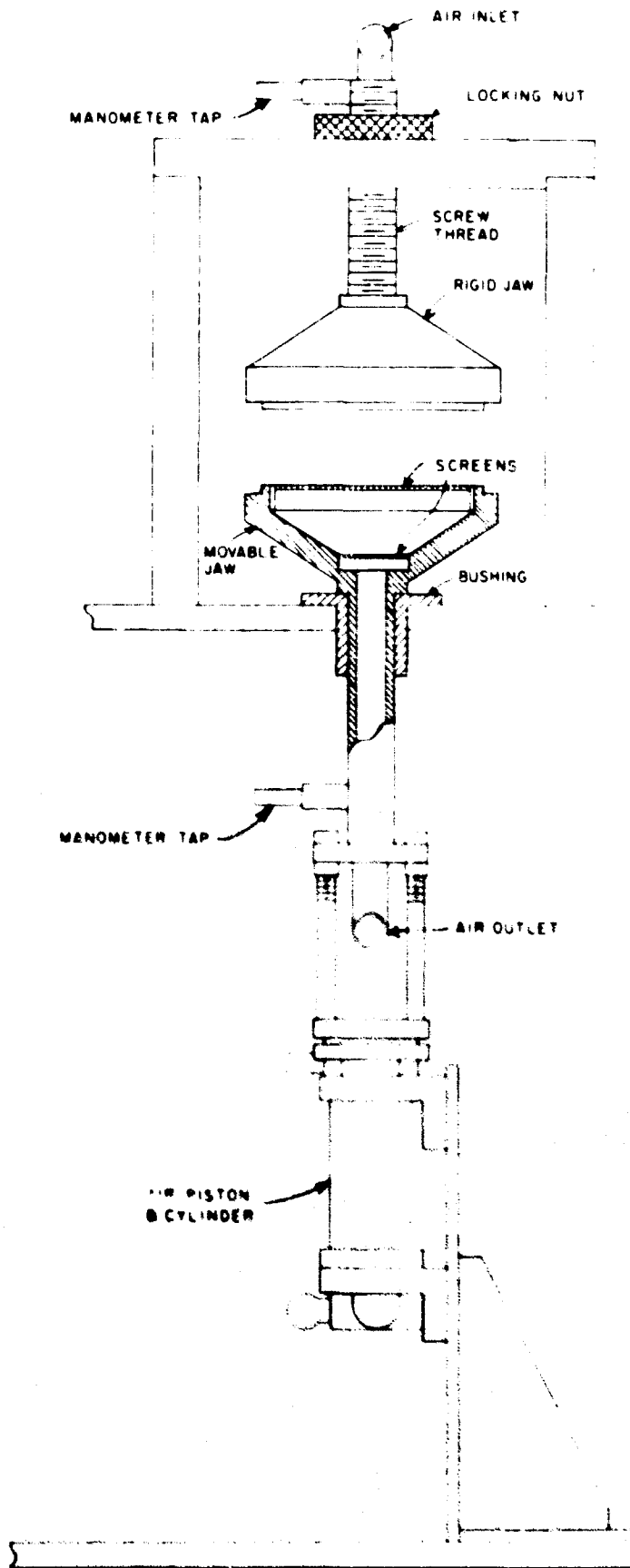

Fig. 5 - Sketch of clamping chuck and air piston.

pressure effect would diminish with decreasing resistance, a filter with a resistance of 243 mm of water at 85 liters/min airflow was selected to measure the magnitude of this effect. With the same differential pressure across the orifice plate, airflow as measured with the wet test meter decreased five parts per thousand with the filter in place as compared with the original calibration without the filter. It is thus evident that the calibration of the resistance meter is not significantly affected by the resistance of filter materials in the range for which the meter was designed.

The reproducibility obtainable with the meter is excellent in that replicate samples give values within 0.2%. The accuracy as determined by the use of auxiliary manometers, standard rotameters, and by comparison of standard filters with the original equipment is estimated to be less than the limitation of reading the resistance manometer, or approximately 0.5 millimeter.

OPERATION

To operate the machine, the bypass valve (Fig. 3) is set on "atmosphere" and the vacuum pump started. A rubber gasket is inserted to insure sealing of the clamping chuck. The control switch is moved to the "up" position to effect closure of the chuck. The control valve on one of the three systems is opened and the desired flow rate established by adjusting this valve. The resistance manometer is then adjusted to give a zero reading, thus compensating for the pressure drop across the empty chuck and the screens. Theoretically, a zero setting would be necessary for each flow used, but in actual practice, a zero setting for each flow channel is sufficiently accurate. After the zero adjustment, the switch is pushed to "down" position to open the chuck and the rubber gasket is removed.

After the sample is inserted in the clamping chuck, the chuck is closed and air is drawn through the sample at the desired rate of flow. Air resistance in mm of water is read directly from the resistance scale. The chuck is again opened, the sample removed, and another inserted. Special sizes or shapes of filter materials are accommodated by an adjustment of the semirigid jaw of the clamping chuck, or by fabricating auxiliary inserts.

Tests should be made periodically to determine leakage, if any, of the control valves in the unused flow channels. With full vacuum from the pump and all three control valves closed, a 200-cc-capacity rotameter connected to the atmosphere upstream of the valves showed no measurable leak after more than a year's operation of the equipment.

Simultaneous measurement of air resistance and smoke penetration is accomplished by attaching a connecting hose from the NRL E-3 Smoke Penetration Meter (1) to the "atmosphere" side of the bypass valve of the air resistance meter. The vacuum pump of the smoke meter draws air through both systems with resistances and penetrations being observed.

REFERENCES

1. Knudson, H.W., and White, L., "Development of Smoke Penetration Meters," NRL Report P2642, Sept. 14, 1945
2. Bogardus, H.F., "The Navy Diaphragm Gas Mask Canister, Type B-2," NRL Report P2876, May 15, 1946
3. Bogardus, H.F., "The Development of Low-Resistance Lightweight Gas Mask Canisters," NRL Report 5349 (Confidential Report, Unclassified Title), Oct. 1959

DOCUMENT CONTROL DATA - R&D		
<small>(Security classification of title, body of abstract and indexing annotation must be entered when the overall report is classified)</small>		
1 ORIGINATING ACTIVITY (Corporate author) U.S. Naval Research Laboratory Washington, D.C. - 20390		2a REPORT SECURITY CLASSIFICATION UNCLASSIFIED
		2b GROUP
3 REPORT TITLE THE NRL AIR RESISTANCE METER, MODEL II		
4 DESCRIPTIVE NOTES (Type of report and inclusive dates) A final report on one phase of the problem.		
5 AUTHOR(S) (Last name, first name, initial) Lawrence, K.D., Young, J.A., and Collins, R.H.		
6 REPORT DATE October 30, 1964	7a TOTAL NO OF PAGES 9	7b NO OF REFS 3
8a CONTRACT OR GRANT NO. NRL Problem C05-17	9a ORIGINATOR'S REPORT NUMBER(S) NRL Report 6173	
b PROJECT NO. RR 001-01-43-4701	9b OTHER REPORT NO(S) (Any other numbers that may be assigned this report)	
c		
d		
10 AVAILABILITY/LIMITATION NOTICES Unlimited availability - Copies available from OTS - \$.50		
11 SUPPLEMENTARY NOTES	12 SPONSORING MILITARY ACTIVITY Dept. of the Navy (Office of Naval Research)	
13 ABSTRACT <p>The resistance to airflow is one of the basic characteristics of aerosol filtration materials. With the relatively recent study and development of new low-resistance filters and canisters, there was a need for an improved air resistance meter. In response to this need, NRL designed a new air resistance meter which provides accuracy, versatility, and rapidity of measurement. It utilizes a system of three parallel air lines, each designed to accommodate a specific range of airflows and each with its own separate control valve. These serve to furnish a more accurately calibrated span of airflows up to 100 liters/minute. The instrument is mounted on a table making a convenient semiportable laboratory device.</p> <p>This device has a pneumatically operated chuck to hold the filter sample. The chuck provides uniformity and rapidity of operation and is designed to allow inserts and other alterations to be made easily.</p> <p>The new air resistance meter can be used in conjunction with other equipment to measure airflow resistance and aerosol penetration simultaneously.</p>		

Security Classification

14. KEY WORDS	LINK A		LINK B		LINK C	
	ROLE	WT	ROLE	WT	ROLE	WT
Airflow Air resistance meter Airflow calibration Aerosol filtration materials Aerosol penetration Canisters Orifices Filter papers Filter paper holder design Aerosols Airflow resistance						

INSTRUCTIONS

1. **ORIGINATING ACTIVITY:** Enter the name and address of the contractor, subcontractor, grantee, Department of Defense activity or other organization (*corporate author*) issuing the report.
- 2a. **REPORT SECURITY CLASSIFICATION:** Enter the overall security classification of the report. Indicate whether "Restricted Data" is included. Marking is to be in accordance with appropriate security regulations.
- 2b. **GROUP:** Automatic downgrading is specified in DoD Directive 5200.10 and Armed Forces Industrial Manual. Enter the group number. Also, when applicable, show that optional markings have been used for Group 3 and Group 4 as authorized.
3. **REPORT TITLE:** Enter the complete report title in all capital letters. Titles in all cases should be unclassified. If a meaningful title cannot be selected without classification, show title classification in all capitals in parenthesis immediately following the title.
4. **DESCRIPTIVE NOTES:** If appropriate, enter the type of report, e.g., interim, progress, summary, annual, or final. Give the inclusive dates when a specific reporting period is covered.
5. **AUTHOR(S):** Enter the name(s) of author(s) as shown on or in the report. Enter last name, first name, middle initial. If military, show rank and branch of service. The name of the principal author is an absolute minimum requirement.
6. **REPORT DATE:** Enter the date of the report as day, month, year, or month, year. If more than one date appears on the report, use date of publication.
- 7a. **TOTAL NUMBER OF PAGES:** The total page count should follow normal pagination procedures, i.e., enter the number of pages containing information.
- 7b. **NUMBER OF REFERENCES:** Enter the total number of references cited in the report.
- 8a. **CONTRACT OR GRANT NUMBER:** If appropriate, enter the applicable number of the contract or grant under which the report was written.
- 8b, c, & 8d. **PROJECT NUMBER:** Enter the appropriate military department identification, such as project number, subproject number, system numbers, task number, etc.
- 9a. **ORIGINATOR'S REPORT NUMBER(S):** Enter the official report number by which the document will be identified and controlled by the originating activity. This number must be unique to this report.
- 9b. **OTHER REPORT NUMBER(S):** If the report has been assigned any other report numbers (*either by the originator or by the sponsor*), also enter this number(s).
10. **AVAILABILITY/LIMITATION NOTICES:** Enter any limitations on further dissemination of the report, other than those

imposed by security classification, using standard statements such as:

- (1) "Qualified requesters may obtain copies of this report from DDC."
- (2) "Foreign announcement and dissemination of this report by DDC is not authorized."
- (3) "U. S. Government agencies may obtain copies of this report directly from DDC. Other qualified DDC users shall request through _____."
- (4) "U. S. military agencies may obtain copies of this report directly from DDC. Other qualified users shall request through _____."
- (5) "All distribution of this report is controlled. Qualified DDC users shall request through _____."

If the report has been furnished to the Office of Technical Services, Department of Commerce, for sale to the public, indicate this fact and enter the price, if known.

11. **SUPPLEMENTARY NOTES:** Use for additional explanatory notes.

12. **SPONSORING MILITARY ACTIVITY:** Enter the name of the departmental project office or laboratory sponsoring (*paying for*) the research and development. Include address.

13. **ABSTRACT:** Enter an abstract giving a brief and factual summary of the document indicative of the report, even though it may also appear elsewhere in the body of the technical report. If additional space is required, a continuation sheet shall be attached.

It is highly desirable that the abstract of classified reports be unclassified. Each paragraph of the abstract shall end with an indication of the military security classification of the information in the paragraph, represented as (TS) (S) (C) or (U)

There is no limitation on the length of the abstract. However, the suggested length is from 150 to 225 words.

14. **KEY WORDS:** Key words are technically meaningful terms or short phrases that characterize a report and may be used as index entries for cataloging the report. Key words must be selected so that no security classification is required. Identifiers, such as equipment model designation, trade name, military project code name, geographic location, may be used as key words but will be followed by an indication of technical context. The assignment of links, roles, and weights is optional.

UNCLASSIFIED

Naval Research Laboratory. Report 6173.
THE NRL AIR RESISTANCE METER, MODEL II, by
R.H. Collins, K.D. Lawrence, and J.A. Young, 8 pp. and
figs., October 30, 1964.

The resistance to airflow is one of the basic characteristics of aerosol filtration materials. With the relatively recent study and development of new low-resistance filters and canisters, there was a need for an improved air resistance meter. In response to this need, NRL designed a new air resistance meter which provides accuracy, versatility, and rapidity of measurement. It utilizes a system of three parallel air lines, each designed to accommodate a specific range of airflows and each with its own separate

UNCLASSIFIED (over)

1. Air - Resistance - Meas.
2. Gas flow - Resistance - Meas.
- I. Collins, R.H.
- II. Lawrence, K.D.
- III. Young, J.A.

UNCLASSIFIED

Naval Research Laboratory. Report 6173.
THE NRL AIR RESISTANCE METER, MODEL II, by
R.H. Collins, K.D. Lawrence, and J.A. Young, 8 pp. and
figs., October 30, 1964.

The resistance to airflow is one of the basic characteristics of aerosol filtration materials. With the relatively recent study and development of new low-resistance filters and canisters, there was a need for an improved air resistance meter. In response to this need, NRL designed a new air resistance meter which provides accuracy, versatility, and rapidity of measurement. It utilizes a system of three parallel air lines, each designed to accommodate a specific range of airflows and each with its own separate

UNCLASSIFIED (over)

1. Air - Resistance - Meas.
2. Gas flow - Resistance - Meas.
- I. Collins, R.H.
- II. Lawrence, K.D.
- III. Young, J.A.

UNCLASSIFIED

Naval Research Laboratory. Report 6173.
THE NRL AIR RESISTANCE METER, MODEL II, by
R.H. Collins, K.D. Lawrence, and J.A. Young, 8 pp. and
figs., October 30, 1964.

The resistance to airflow is one of the basic characteristics of aerosol filtration materials. With the relatively recent study and development of new low-resistance filters and canisters, there was a need for an improved air resistance meter. In response to this need, NRL designed a new air resistance meter which provides accuracy, versatility, and rapidity of measurement. It utilizes a system of three parallel air lines, each designed to accommodate a specific range of airflows and each with its own separate

UNCLASSIFIED (over)

1. Air - Resistance - Meas.
2. Gas flow - Resistance - Meas.
- I. Collins, R.H.
- II. Lawrence, K.D.
- III. Young, J.A.

UNCLASSIFIED

Naval Research Laboratory. Report 6173.
THE NRL AIR RESISTANCE METER, MODEL II, by
R.H. Collins, K.D. Lawrence, and J.A. Young, 8 pp. and
figs., October 30, 1964.

The resistance to airflow is one of the basic characteristics of aerosol filtration materials. With the relatively recent study and development of new low-resistance filters and canisters, there was a need for an improved air resistance meter. In response to this need, NRL designed a new air resistance meter which provides accuracy, versatility, and rapidity of measurement. It utilizes a system of three parallel air lines, each designed to accommodate a specific range of airflows and each with its own separate

UNCLASSIFIED (over)

1. Air - Resistance - Meas.
2. Gas flow - Resistance - Meas.
- I. Collins, R.H.
- II. Lawrence, K.D.
- III. Young, J.A.

UNCLASSIFIED

control valve. These serve to furnish a more accurately calibrated span of airflows up to 100 liters/minute. The instrument is mounted on a table making a convenient semiportable laboratory device.

This device has a pneumatically operated chuck to hold the filter sample. The chuck provides uniformity and rapidity of operation and is designed to allow inserts and other alterations to be made easily.

The new air resistance meter can be used in conjunction with other equipment to measure airflow resistance and aerosol penetration simultaneously.

UNCLASSIFIED

UNCLASSIFIED

control valve. These serve to furnish a more accurately calibrated span of airflows up to 100 liters/minute. The instrument is mounted on a table making a convenient semiportable laboratory device.

This device has a pneumatically operated chuck to hold the filter sample. The chuck provides uniformity and rapidity of operation and is designed to allow inserts and other alterations to be made easily.

The new air resistance meter can be used in conjunction with other equipment to measure airflow resistance and aerosol penetration simultaneously.

UNCLASSIFIED

UNCLASSIFIED

control valve. These serve to furnish a more accurately calibrated span of airflows up to 100 liters/minute. The instrument is mounted on a table making a convenient semiportable laboratory device.

This device has a pneumatically operated chuck to hold the filter sample. The chuck provides uniformity and rapidity of operation and is designed to allow inserts and other alterations to be made easily.

The new air resistance meter can be used in conjunction with other equipment to measure airflow resistance and aerosol penetration simultaneously.

UNCLASSIFIED

control valve. These serve to furnish a more accurately calibrated span of airflows up to 100 liters/minute. The instrument is mounted on a table making a convenient semiportable laboratory device.

This device has a pneumatically operated chuck to hold the filter sample. The chuck provides uniformity and rapidity of operation and is designed to allow inserts and other alterations to be made easily.

The new air resistance meter can be used in conjunction with other equipment to measure airflow resistance and aerosol penetration simultaneously.

UNCLASSIFIED

UNCLASSIFIED