

AD 609049

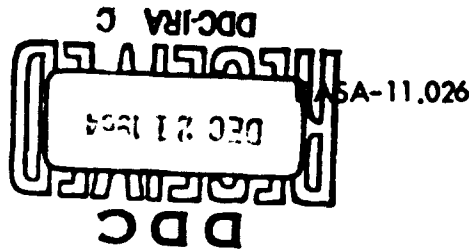

R 349

Technical Report

AN EMPIRICAL FORMULA
 FOR CALCULATING GAMMA-RAY
 DOSE ATTENUATION IN CONCRETE
 DUCTS

25 November 1964

COPY	2	OF	3	901
HARD COPY	\$. 2.00			
MICROFICHE	\$. 6.75			

64 p



U. S. NAVAL CIVIL ENGINEERING LABORATORY
 Port Hueneme, California

Best Available Copy

ARCHIVE COPY

AN EMPIRICAL FORMULA FOR CALCULATING GAMMA-RAY DOSE ATTENUATION IN CONCRETE DUCTS

Y-F008-08-05-201, DASA-11.026

Type C

by

W. C. Ingold and C. M. Huddleston

ABSTRACT

A survey is presented of the current status of the calculation of gamma-ray dose-rate attenuation in air ducts through concrete. A simple empirical formula is exhibited which shows satisfactory agreement with the results of more complicated computational techniques and with experimental results. This simple formula represents a large saving in computation time — 2 seconds per case compared to 400 seconds by IBM-1620 computer. Its validity is established for a wide range of duct geometries and for gamma-ray energies up to 3 Mev.

Copies available at OTS \$2.00

Qualified requesters may obtain copies of this report from DDC.
The Laboratory invites comment on this report, particularly on the
results obtained by those who have applied the information.
This work sponsored by the Defense Atomic Support Agency

CONTENTS

	Page
INTRODUCTION	1
THEORY OF DUCT STREAMING	1
AN EMPIRICAL FORMULA FOR DOSE ATTENUATION CALCULATIONS	7
SAMPLE PROBLEMS	15
CONCLUSIONS	20
ACKNOWLEDGMENTS	20
REFERENCES	21
APPENDIXES	
A — Chapman's Computer Code for Computing Gamma-Ray Dose Rates in Two-legged Concrete Ducts	23
B — Comparison of the Empirical Formula with Other Computational Techniques	47
DISTRIBUTION LIST	62

INTRODUCTION

In the shielding of personnel against gamma radiation from nuclear weapons, an important aspect of the problem is consideration of the hazard caused by radiation which is scattered off interior surfaces of entranceways and air ducts into the shelter area. The duct streaming problem has been investigated both experimentally and theoretically at several laboratories. In this report a brief review will be given of some theoretical approaches to the problem of gamma-ray streaming through ducts. The calculational methods up to the present time, although quite accurate, have been very complicated and time consuming.

The method of Chapman¹ will be discussed in some detail, since the object of the present effort was to duplicate Chapman's results by less laborious means.

An empirical formula will be developed to relate dose attenuation factors to gamma-ray energy and duct geometry. A comparison will be made between predictions of the empirical formula and the results of other computational techniques. Also, comparisons will be drawn between results of the formula and experimental results. It will be demonstrated that the formula gives satisfactory results over a wide region of interest.

Some sample problems will be worked to demonstrate the practical usefulness of the empirical formula, and the accuracy and reliability of the formula will be discussed, and its limitations will be delineated.

THEORY OF DUCT STREAMING

In the past, several investigators have attacked the theoretical problem of gamma-ray streaming through air ducts in concrete. In order to discuss their work as well as the empirical formula to be developed, a standard terminology is adopted as follows:

D = Measured dose rate in mr/hr at some distance along the axis of the duct

D_0 = Dose rate in mr/hr at unit distance from source in air

Preceding Page Blank

D_1 = Dose rate in mr/hr in center of first corner of duct

L_1 = Length of first leg, measured from the source to the center of the first corner

l_1 = Distance from source to detector in first leg

L_2 = Length of second leg, of a two-legged duct measured from the center of the first corner to the end of the duct

l_2 = Distance from center of first corner to detector in second leg of a two-legged duct

H = Height of duct

W_1 = Width of first leg of duct

W_2 = Width of second leg of duct

W = Width of duct if $W_1 = W_2$

One of the earliest investigators was Eisenhauer,² who developed a theoretical model to account for the results of his experimental findings with a Co^{60} point source in two-legged and three-legged rectangular air ducts in concrete. He observed that dose fell off in the second leg of a duct according to the relationship

$$\frac{D}{D_1} \propto \frac{1}{l_2^3}$$

Seeking another relationship, Eisenhauer found

$$\frac{D}{D_1} \propto \frac{1}{l_2'^2}$$

where $l_2' = l_2 - (W/2) - (1/\mu)$

μ = the absorption coefficient of Co^{60} gamma rays in concrete.

Eisenhauer was thus able to show that dose rates along the axis of his ducts were proportional to the solid angle subtended by the detector, provided the proper origin was selected. In the second leg, then, Eisenhauer had

$$\frac{D}{D_0} = \frac{K_1}{t_2^2}$$

where K_1 is an empirical constant which can be justified approximately from theoretical arguments.

Most treatments of the streaming of gamma radiation through air ducts in concrete are based on the method of LeDoux and Chilton.³ Their method can be explained by reference to Figure 1. The Areas A_1 , A_2 , A_3 , and A_4 are called primary scattering areas because they are visible from both the source and detector positions. It is reasonable, therefore, to suppose that most radiation reaching the detector should be scattered from the primary scattering areas. Using approximate values for differential dose albedo and invoking solid-angle arguments, LeDoux and Chilton were able to calculate the primary scattering effects. Not having available to them accurate values for differential dose albedo, they used total albedo values, assuming isotropic scattering. LeDoux and Chilton also developed an analytical method for treating corner-lip transmission effects and corner-lip in-scattering effects. Their results generally gave good qualitative agreement with experiment, but theoretical predictions were low because of neglect of multiple-scatter contributions.

Chilton⁴ subsequently extended the analytical method to cases where the source and/or detector are located off the axis of the duct.

Terrell⁵ used the best values then available for differential dose albedo. He numerically integrated dose scattering contributions from the various interior surfaces of a duct. Multiple scattering was accounted for by the use of a build-up factor.

Subsequently, Terrell⁶ described a computerized method for performing numerical integrations of backscattered dose, still using a build-up factor to account for multiple scatter. The method appeared to give good results but remains subject to question because reliable values for differential dose albedo were not then available.

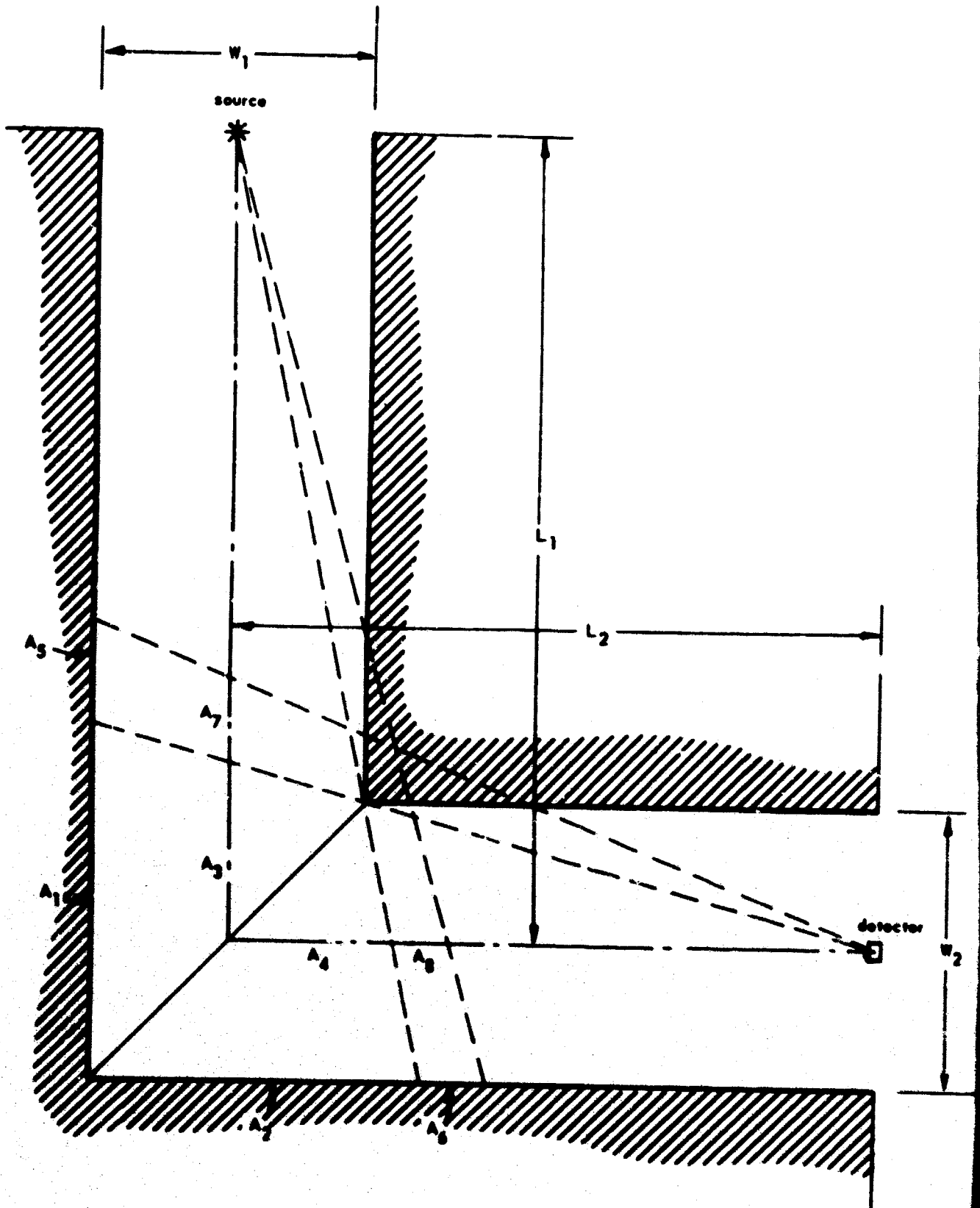

Figure 1. Duct geometry showing scattering areas.

Another computer code for performing numerical integrations of dose backscatter of gamma rays from interior walls of ducts was written by Silverman and his co-workers.⁷ The computer code treated only single scattering, although a method was outlined for treating second reflections, because the spectral distribution of gamma rays backscattered from concrete was not well known.

Ingold¹¹ made calculations on Co⁶⁰ and Cs¹³⁷ gamma-ray penetration through straight air ducts in concrete. Using the single-scatter approximation and using the semiempirical albedo formula of Chilton and Huddleston,¹² Ingold, using a computerized numerical integration, showed that a square duct and a round one of the same cross-sectional area have almost identical attenuation properties for all duct lengths and for each energy studied. This computational result is in agreement with the experimental findings of Fowler and Dorn.¹³

Ingold also wrote a computer program to treat second reflections within a straight cylindrical duct. A difficulty arose because the albedo value for second reflection depends on the energy of the once-scattered photon incident at the second reflection surface. Even if backscattered gamma-ray energy spectra were well known, an integration over the spectra would be required for an exact calculation. As an approximation, Ingold assumed that the gamma-ray energy incident to the second reflection was single-valued. The value taken was that computed for the emergent ray of the first reflection, assuming a single Compton scatter.

Chapman¹ devised a computer program (Appendix A) to extend the LeDoux-Chilton technique for two-legged ducts to include double-scatter effects, using the method of Ingold.¹¹ The first-order effects (Figure 1) described by LeDoux³ are included as one part of the four-part program. Second-order scatterings are handled in the manner described by Ingold.¹¹ In addition, Chapman treats other second-order effects such as a wall backscatter followed by a corner-lip inscatter. Chapman's method also gives relative dose contributions of the various first- and second-order effects. Table A-VI of Appendix A illustrates the ratio of the contribution of each part of the problem to the entire dose rate for selected theoretical

* Measurements of the energy spectra of gamma rays from Co⁶⁰ and Cs¹³⁷ back-scattered from semi-infinite slabs of paraffin, aluminum, iron, tin, and lead have been performed by Hyodo.⁸ Also, Monte Carlo calculations of the albedo of 1-Mev gamma rays reflected from semi-infinite slabs of water, aluminum, copper, tin, and lead at various angles of incidence have been performed by Hayward and Hubbell.⁹ Another description of a gamma-ray backscattering experiment is given by Hayward and Hubbell.¹⁰

cases. It is to be noted that the ratios of the lip effect to the total dose rate fall off sharply as L_1 and L_2 become increasingly long in comparison to the width, as was predicted by Eisenhauer.²

The results of calculations (Table A-VII) are compared with experimental data^{2, 5, 6, 14, 15, 16} for ducts whose widths vary from 11 inches to 6 feet, using Co^{60} , Cs^{137} , Au^{198} , and Na^{24} gamma-ray sources. The calculated dose rates agree to within ± 30 percent for all ducts and all sources, except for small ducts with Cs^{137} sources, ducts with very short first legs ($L_1/W \leq 1.33$), and for Au^{198} sources. The worst disagreement is for the Au^{198} case. Experiments for this case should be repeated.

Since agreement between Chapman's calculations and experiment is excellent in most cases, it seems reasonable to believe that his calculations can be trusted to be accurate anywhere within the domain of energy and duct geometry where it has been tested. Thus, for the argument to follow, it will be assumed that Chapman's calculations can be accepted as true, even in cases where the calculations disagree with experiment. There are two strong reasons justifying this confidence in the Chapman Code. They are:

1. Recent experiments¹⁷ have been conducted to study the energy spectra of gamma radiation within a duct. Some shadow-shield experiments were also made to determine the relative importance of various internal scattering areas. The results of this experimental study confirmed very closely the predictions of the Chapman Code for individual dose-rate contributions.

2. It is clear that attenuation factors must increase as the energy of the gamma-ray source decreases. Therefore, among the various sources experimentally investigated, the smallest attenuation factor should obtain for Na^{24} while the attenuation factor for Au^{198} should be the largest, provided the duct geometry is the same. However, experimental results⁶ indicate a smaller attenuation factor for Au^{198} radiation than for Cs^{137} radiation. On the other hand, the Chapman Code gives monotonically decreasing dose attenuation factors as the gamma-ray source energy increases.

For the two reasons stated above, it is believed to be justified to use the results of Chapman's calculations rather than actual experimental results when attempting to develop a quick way to calculate approximate gamma-ray dose attenuation factors for air ducts in concrete.

AN EMPIRICAL FORMULA FOR DOSE ATTENUATION CALCULATIONS

In light of the general consistency of the Chapman Code with experimental work and the illustrated inconsistencies in some of the experimental measurements, a formula to fit Chapman's calculations rather than experimental results was sought.

In an attempt to discover relationships, a group of 54 ducts was chosen for a preliminary study for three selected energies (0.662 Mev, 1.25 Mev, and 6 Mev). The ducts had 1-foot and 6-foot square cross sections with ratios of L_1/W , L_2/W equal to the integers 4, 5, and 6. These longer ducts were chosen to minimize the contribution of the comer-lip effect.

The array of dose attenuation factors of the 162 cases is shown in Table B-1 of Appendix B. The four contributions to the total dose are:

1. Comer-lip inscatter (LC). This calculation accounts for two effects:
 - a. The scattering of photons at the interior comer lip in such a way that radiation from the source is deflected so as to reach the detector.
 - b. A combination, in either order, of a penetration through the comer lip and a backscatter at an interior surface of the duct. Comer-lip inscatter is illustrated by Figure 2.

2. Multiple comer inscatter (MC). This calculation takes care of the case where there is a combination, in either order, of an interior surface backscatter and a comer-lip inscatter. The four possible cases representing multiple comer inscatter are shown in Figure 3.

3. Primary comer areas incremented (CI). This calculation is concerned with scattering from those "primary scattering areas" which are within a direct line of vision from both the source and the detector. The primary scattering areas are A_1 , A_2 , A_3 , and A_4 . These areas are incremented by areas A_5 and A_6 which can see the detector or the source, respectively, through the comer lip by uncollided penetration, as shown in Figure 1.

4. Multiple surface scatter (MS). This final computer calculation treats two consecutive interior surface backscatters which cause a photon from the source to reach the detector. A typical case of this type is shown in Figure 4.

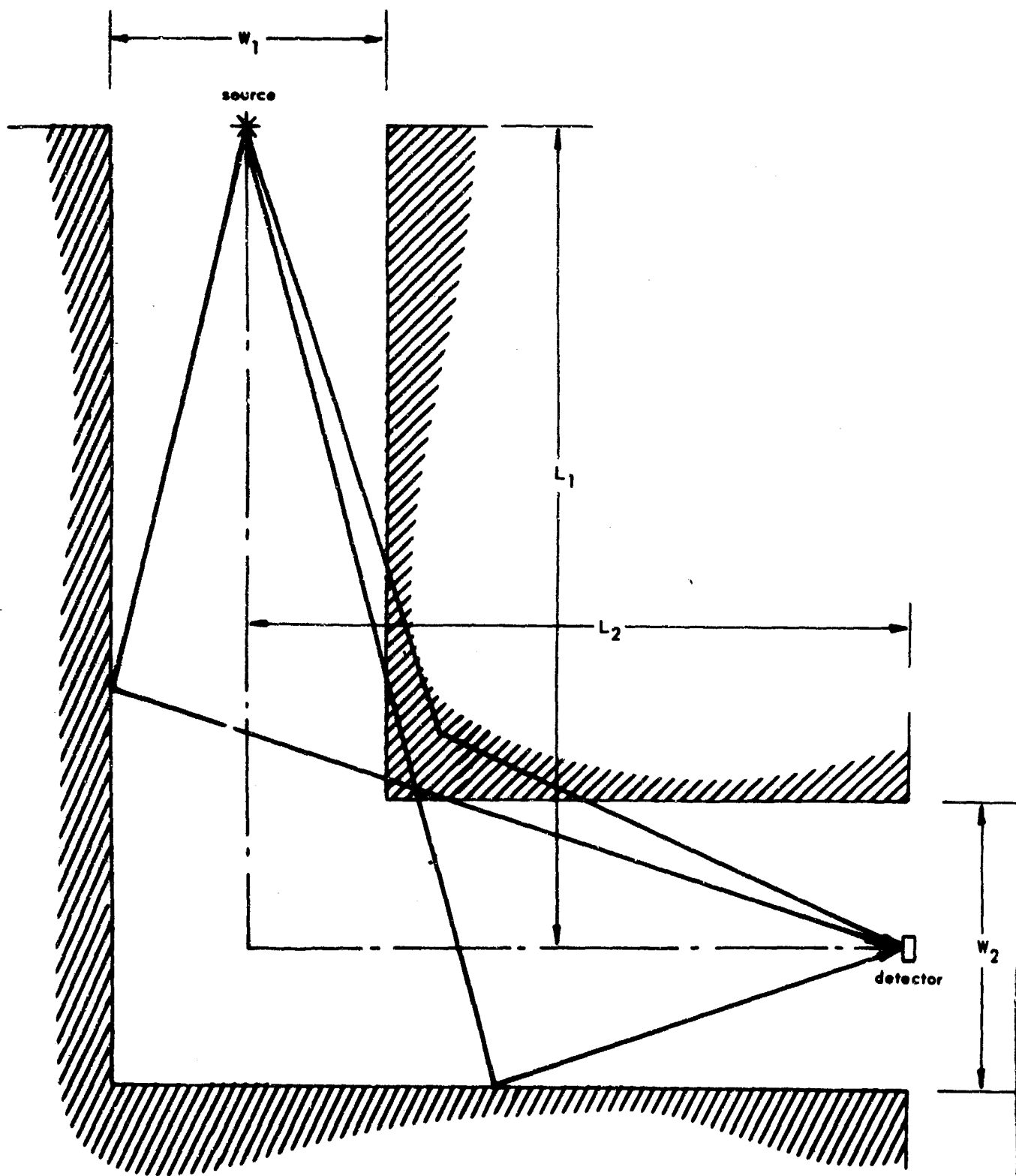

Figure 2. Illustration of corner-lip inscatter.

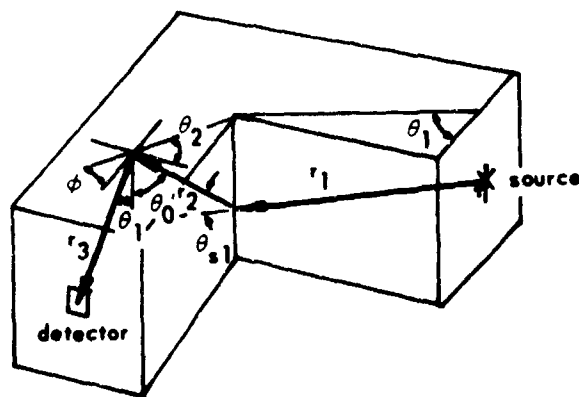
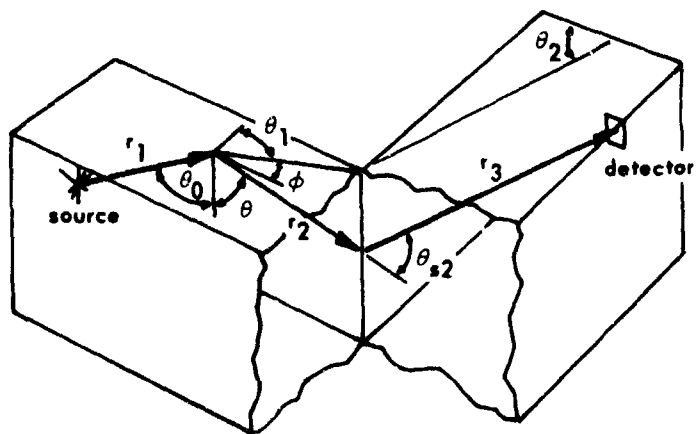
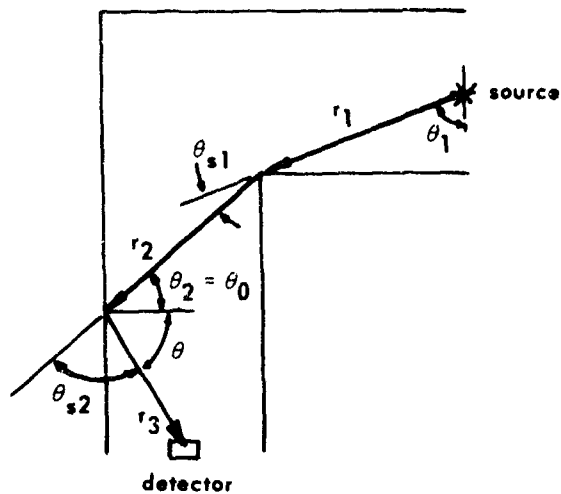
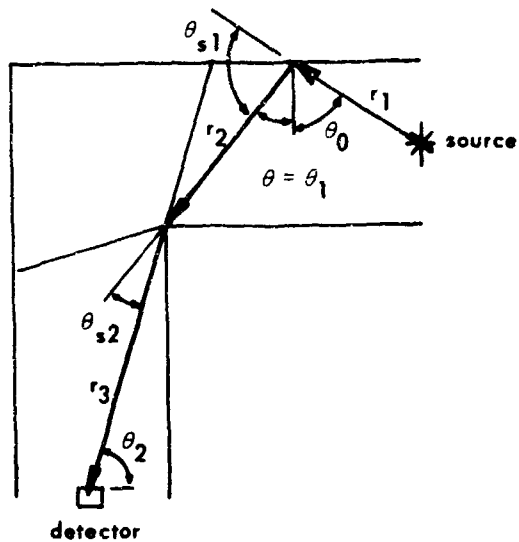

Figure 3. Geometry for multiple corner inscattering with scattering surfaces in the first and second legs.

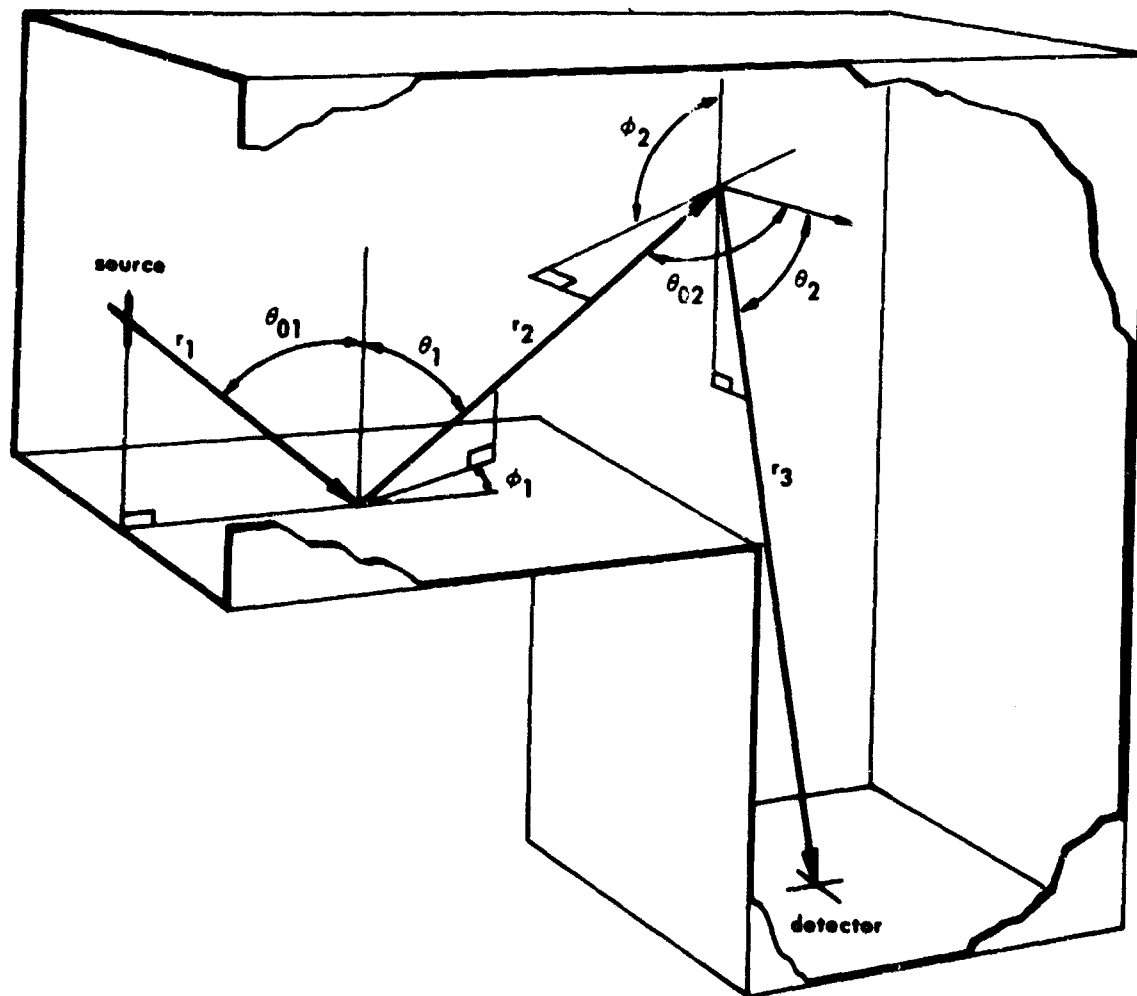

Figure 4. Typical geometry for multiple scattering.

The array of attenuation factors of the 162 cases of Table B-1, computed with the Chapman Code, displayed certain apparent tendencies:

1. The contributions based on the geometry of a duct (CI and MS) varied inversely with the square of the width. In Table B-1, $D_0 = 36$ was inserted in the 6-foot cases to compensate for the size effect relative to its 1-foot counterpart.
2. The addition of one duct width, W , to L_1 or L_2 reduced the output to roughly one-half that of the preceding case. When plotted, attenuation factors seemed to fall off approximately as the inverse cube of the product of L_1/W and L_2/W .
3. Most striking was the observation that the influence of initial energy was such that attenuation factors fell off with increasing energy in a manner approximately proportional to $E_0^{-2/3}$.
4. Eccentricity of cross-sectional area (H/W) indicated an influence not accounted for by other factors.

These observations indicated a possibility that a dose attenuation formula might be expressed as a product of the various factors involved. Tentatively this was assumed to be

$$\frac{D}{D_0} = A \frac{\left(\frac{H}{W}\right)^{a_1} W^{a_2}}{L_1^{a_3} L_2^{a_4} E_0^{a_5}} \quad (1)$$

In order to test the hypothesis stated by Equation 1, 60 cases in the region of interest were randomly selected. The 60 cases were chosen so as to satisfy all of the following inequalities:

$$0.662 \leq E_0 \leq 6.000 \text{ Mev}$$

$$1.0 \leq H \leq 6.0 \text{ feet}$$

$$1.0 \leq W \leq 6.0 \text{ feet}$$

$$2 \leq L_1 \leq 36 \text{ feet}$$

$$1 \leq \frac{H}{W} \leq 2$$

$$\frac{L_1}{H} \leq 6$$

$$\frac{L_2}{H} \leq 6$$

$$\frac{L_1}{W} \leq 2$$

$$\frac{L_2}{W} \leq 2$$

Chapman's Code was used to compute the attenuation factor for each of these randomly chosen ducts. Formula 1 was then converted to linear form by taking the natural logarithm of each member, producing an equation of the form

$$\ln \frac{D}{D_0} = \ln A + a_1 \ln \frac{H}{W} + a_2 \ln W \\ + a_3 \ln L_1 + a_4 \ln L_2 + a_5 \ln E_0$$

in order that a regression analysis might be performed to fit the exponents to the 60 case solutions. An IBM-1620 computer program, "Stepwise Regression Analysis Program" (STRAP) Revised,¹⁸ was used to perform this analysis. The parameters were found to be

$$A = 0.155$$

$$a_3 = -2.498$$

$$a_1 = 0.982$$

$$a_4 = -2.626$$

$$a_2 = 2.858$$

$$a_5 = -0.637$$

When the formula of Equation 1 with these parameters was used to compute the test cases, very close agreement (standard deviation, $\sigma \approx 5\%$) was found with Chapman's solutions. When applied to the different, though slightly overlapping, domain of experimental ducts and energies of Table 1, it was found that, in general, results were 30 to 40 percent low.

A regression analysis was then done on the 60 cases in Table 1, again using Chapman's solutions as the dependent variable in the analysis. The parameters found for this problem were:

$$\begin{array}{ll}
 A = 0.248 & a_3 = -2.672 \\
 a_1 = 1.000 & a_4 = -2.611 \\
 a_2 = 2.893 & a_5 = -0.739
 \end{array}$$

Since all these were square ducts, the eccentricity factor (H/W) did not enter in; hence $a_1 = 1.000$. It is to be noted that the greatest difference between the two sets of parameters lies in the multiplicative constant. The second set of parameters gave quite accurate results in the experimental domain, with the exception of cases where the first leg was very short ($L_1 \leq 1.33 W$). However, agreement was erratic when the second set of parameters was used to calculate the attenuation factors for the 60 randomly selected hypothetical cases.

Nevertheless, inspection shows that the two sets of parameters are not greatly different. Therefore, it seemed reasonable to combine all 120 cases and to perform still another regression analysis. Before doing this, however, four cases from the experimental domain were eliminated because the first legs were very short. The formula was then found to be

$$\frac{D}{D_0} = 0.214 \frac{\left(\frac{H}{W}\right)^{0.907} W^{2.864}}{L_1^{2.534} L_2^{2.667} E_0^{0.710}} \quad (2)$$

Table I. Comparison of Calculated and Measured Dose Rates

Data Source	Gamma-Ray Source	W	L_1/W	L_2/W	Dose Rates (mr/hr)		% Difference ^{1/}				
					Calculated	Measured					
Green ¹⁴	0.34c Co-60	11 in.	1.90	1.65	87.3	125	-30				
				2.06	44.5	61	-27				
				2.46	27.1	30.5	-11				
			3.58	3.68	8.46	7.31	+16				
				2.06	6.17	7.3	-15				
				2.86	2.61	2.7	-3				
				3.68	1.30	1.3	0				
				Eisenhower ²	0.6c Co-60	11.1 in.	3.54	1.73	17.4	15.6	+11
								2.79	4.94	3.7	-33
3.51	2.65	2.02	+31								
Terrell ¹⁵	55c Co-60	12 in.	3.50	2.0	916	852	+8				
				3.0	317	243	+30				
				4.0	140	110	+28				
Chapman ¹⁶	2.4c Co-60	3 ft	2.0	1.67	20.6	17.5	+18				
				2.0	12.6	12.1	+4				
				2.34	8.35	7.1	+18				
			2.5	1.50	14.5	13.5	+7				
				1.83	8.42	9.1	-8				
				2.0	6.70	6.4	-5				
Terrell ⁵	3.67c Co-60	6 ft	1.33	2.5	3.79	3.7	-2				
				1.83	15.4	11.8	+31				
				2.50	6.56	4.75	+38				
			1.66	3.17	3.47	2.24	+43				
				1.83	7.85	7.30	-8				
				2.50	3.46	2.73	+27				
				3.17	1.85	1.39	+33				
				2.0	1.83	4.71	4.56	+3			
					2.50	2.12	1.79	+18			
3.17	1.14	0.935	+21								
Terrell ¹⁵	80c Cs-137	12 in.	3.5	2.0	606	430	+41				
				3.0	208	132	+58				
				4.0	90	90	+41				
		6 ft	2.17	1.83	36.5	35.5	+3				
			2.33	19.7	19.6	0					
			Terrell ⁵	1.52c Cs-137	6 ft	2.0	1.82	0.858	0.714	+20	
3.17	0.207	0.186					+11				
Terrell ⁶	8.1c Au-198	6 ft					1.66	1.83	6.90	3.22	+114
			2.50	3.09	1.37	+126					
			3.17	1.60	0.738	+121					
		2.17	1.83	3.41	1.66	+105					
			2.50	1.54	0.714	+116					
			3.17	0.818	0.370	+126					
4.2c Na-24	6 ft	1.66	1.83	8.77 ^{2/}	6.78	+29					
			2.50	3.84	2.80	+37					
			3.17	2.05	1.50	+37					
		2.17	1.83	4.17	3.64	+15					
			2.50	1.88	1.67	+13					
			3.17	1.02	0.912	+11					
		2.84	1.83	2.02	1.94	+9					
			2.50	0.931	0.826	+12					
			3.17	0.475	0.462	+3					

^{1/} % Difference = (measured-calculated/measured) 100.

^{2/} The values for Na-24 are the sum of the values obtained using initial gamma-ray energies of 1.37 Mev and 2.75 Mev.

Table B-II of Appendix B shows the results of this formula applied to all 120 of the cases. The Chapman Code required about 6-1/2 minutes of 1620 computer time per case, while less than 2 seconds per case are required using the empirical formula.

A histogram (Figure 5) displays the ratios of the formula solution to the Chapman solution. In the cases plotted, the standard deviation is ≈ 0.07 . Approximately 95 percent of the cases lie within ± 0.14 of the Chapman solution, and approximately two-thirds are within ± 0.07 . If in the design of shelter entranceways a confidence level of 95 percent is desired, the value computed by the formula should be multiplied by 1.15.

Since experimental confirmation is nonexistent above 3 Mev, the validity of the output of this empirical formula, or of Chapman's Code, cannot be checked above that energy. Since fallout radiation has an effective mean energy of approximately 1 Mev, this formula should be quite reliable for fallout shielding calculations. It is uncertain, however, whether the formula is valid for high-energy initial gamma radiation.

To further test the formula, the original 162 cases studied were calculated by formula (R1) and compared with the Chapman solution (RC). The comparison is shown in Table B-III of Appendix B. These 162 cases were not used in the regression analysis to develop the parameters used in the formula, so were an independent group. Inspection of Table B-III shows agreement to be strikingly good.

SAMPLE PROBLEMS

The empirical formula will now be used to calculate dose rates within four sample ducts.

Case 1

Consider a 6-foot square duct with $L_1 = 12$ feet and $L_2 = 11$ feet. The source energy is 1.25 Mev, corresponding to Co^{60} .

Equation 2 is now used:

$$\frac{D}{D_0} = 0.214 \frac{\left(\frac{6}{6}\right)^{0.907} (6^{2.864})}{12^{2.534} (11^{2.667}) (1.25^{0.710})} = 0.976 \times 10^{-4}$$

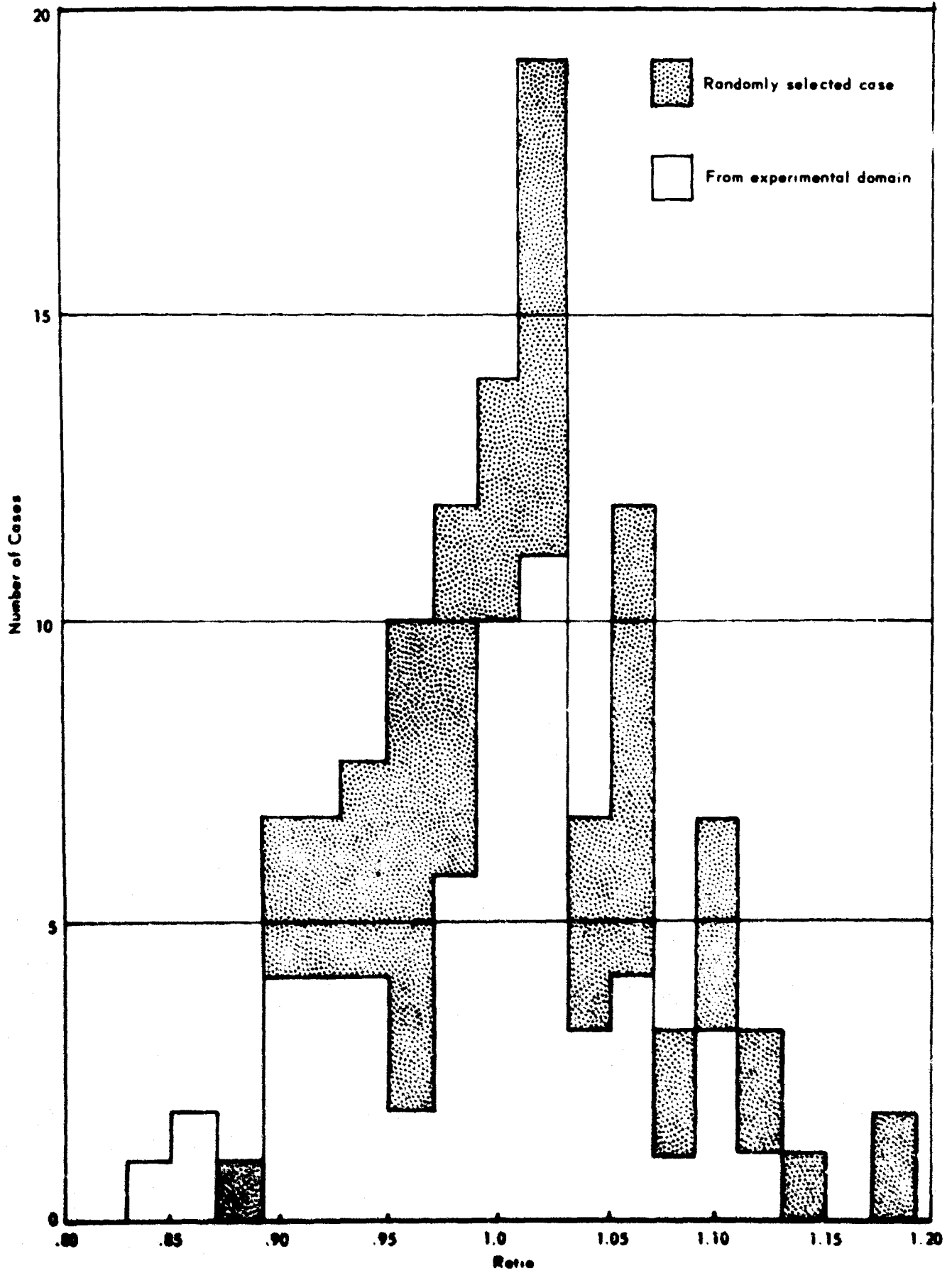

Figure 5. Histogram of 116 Cases showing the ratio of the empirical formula solution to the computer solution.

The above result can be obtained by computer calculation, or by slide rule, or by logarithms.

When the same case is solved using the Chapman computer code, the answer is found to be

$$\frac{D}{D_0} = 0.9038 \times 10^{-4}$$

This case corresponds to an actual experiment performed by Terrell and his co-workers.⁵ The experiment value was found to be

$$\frac{D}{D_0} = 0.8755 \times 10^{-4}$$

It is clearly seen that the results obtained by the empirical formula are sufficiently accurate for shielding calculations.

Case 2

Next, take the case of a 3-foot square duct with $L_1 = 6$ feet and $L_2 = 6$ feet where the gamma-ray source is again Co^{60} (1.25 Mev).

The formula of Equation 2 now gives

$$\frac{D}{D_0} = 0.214 \frac{\left(\frac{3}{3}\right)^{0.707} (3^{2.864})}{6^{2.534} (6^{2.667}) (1.25^{0.710})}$$

Slide-rule solution gives

$$\frac{D}{D_0} = 0.381 \times 10^{-3}$$

The Chapman Code gives

$$\frac{D}{D_0} = 0.3688 \times 10^{-3}$$

The experimental result for this case, obtained by Chapman,¹⁶ is

$$\frac{D}{D_0} = 0.354 \times 10^{-3}$$

Here again, agreement is good between experiment, computer code, and empirical formula.

Case 3

Next consider a smaller duct. Choose an 11-inch (0.917-foot) square duct with $L_1 = 3.28$ feet, and $L_2 = 2.62$ feet. The energy is again taken to be 1.25 Mev. The formula gives

$$\frac{D}{D_0} = 0.214 \frac{\left(\frac{0.917}{0.917}\right)^{0.907} (0.917^{2.864})}{3.28^{2.534} (2.62^{2.667}) (1.25^{0.710})}$$

From the formula,

$$\frac{D}{D_0} = 0.538 \times 10^{-3}$$

The Chapman Code gives

$$\frac{D}{D_0} = 0.5406 \times 10^{-3}$$

The experimental result for this case was found by Green¹⁴ to be

$$\frac{D}{D_0} = 0.559 \times 10^{-3}$$

Case 4

In order to test the formula for a different initial energy, select a 6 x 6-foot square duct with $L_1 = 13$ feet and $L_2 = 11$ feet. For the gamma-ray source, choose Cs^{137} with an energy $E_0 = 0.662$ Mev.

Apply the formula as follows:

$$\frac{D}{D_0} = 0.214 \frac{\left(\frac{6}{6}\right)^{0.907} (6^{2.864})}{13^{2.534} (11^{2.667}) (0.662^{0.710})} = 0.124 \times 10^{-3}$$

The Chapman Code gives

$$\frac{D}{D_0} = 0.1326 \times 10^{-3}$$

The experimental result for this case was found by Terrell¹⁵ to be

$$\frac{D}{D_0} = 0.1289 \times 10^{-3}$$

In all of the above cases excellent agreement is found between experiment and the two methods of calculation.

CONCLUSIONS

An empirical formula has been developed which can be used for hand calculation of attenuation factors of dose rates of gamma-ray streaming through concrete ducts. It provides a vast saving of time — 2 seconds against 400 seconds of computation by IBM-1620 computer — and will handle a wide range of energies and duct geometries. Further refinement of the formula might be made to discover exponents less complicated or to find an additional factor treating the corner-lip effect separately. The latter would be quite useful in working with ducts having first legs $L_1 < 2W$.

A hand calculator such as a nomograph or a slide rule should be developed for use in civil defense work.

This formula might be simplified somewhat for strictly fallout radiation, since most residual radiation has a mean effective energy of approximately 1 Mev, making the E_0 factor drop out as a 1. Log-log graphs might be drawn to handle unwieldy exponents.

Using slide-rule calculations, the formula can be directly solved in its present form:

$$\frac{D}{D_0} = 0.214 \frac{\left(\frac{H}{W}\right)^{0.907} W^{2.864}}{L_1^{2.534} L_2^{2.667} E_0^{0.710}}$$

ACKNOWLEDGMENTS

The authors wish to express their appreciation to Mr. J. M. Chapman of the U. S. Naval Civil Engineering Laboratory (NCEL) for the use of his valuable computer code and for his many helpful suggestions and criticisms during the progress of this work. Mr. W. L. Wilcoxson of NCEL and Mr. J. S. Wohlever of Iowa College kindly assisted in the use of the revised formulation of the "Stepwise Regression Analysis Program" (STRAP). Several useful and stimulating conversations were held with CDR J. C. LeDoux of the Office of Civil Defense, who is vitally interested in this problem.

REFERENCES

1. U. S. Naval Civil Engineering Laboratory. Technical Report R-264: Computer calculation of dose rates in two-legged ducts using the albedo concept, by J. M. Chapman. Port Hueneme, Calif., Oct. 1963.
2. U. S. National Bureau of Standards. Technical Note 74: Scattering of cobalt-60 gamma radiation in air ducts, by C. Eisenhauer. Washington, D. C., Oct. 1960.
3. U. S. Naval Civil Engineering Laboratory. Technical Note N-383: Attenuation of gamma radiation through two-legged rectangular ducts and shelter entranceways; an analytical approach, by J. C. LeDoux and A. B. Chilton. Port Hueneme, Calif., Jan. 1961.
4. _____. Technical Note N-412: Further analysis of gamma-ray attenuation in two-legged rectangular ducts, by A. B. Chilton. Port Hueneme, Calif., May 1961.
5. Armour Research Foundation. Report ARF 1158-12: Radiation streaming in shelter entranceways, by C. W. Terrell et al. Chicago, Ill., Oct. 1960. Contract NBy-3185.
6. _____. Report ARF 1158A01-5: Radiation streaming in shelter entranceways, by C. W. Terrell and A. J. Jerri. Chicago, Ill., July 1961. Contract NBy-3185.
7. University of Maryland, Department of Chemical Engineering. Report UMNE-2: Interim report on scattering of gammas through ducts, by C. M. Park et al. College Park, Md., June 1962.
8. T. Hyodo. Backscattering of gamma rays, Nuclear Science and Engineering, vol. 12, no. 2, Feb., 1962, pp. 178-184.
9. U. S. National Bureau of Standards. Report 2264: An experiment on gamma-ray backscattering, by E. Hayward and J. H. Hubbell. Washington, D. C., Feb., 1953.
10. E. Hayward and J. H. Hubbell. The backscattering of the Co^{60} gamma rays from infinite media, Journal of Applied Physics, vol. 25, no. 4, April 1954, pp. 506-509.
11. U. S. Naval Civil Engineering Laboratory. Technical Note N-469: Some applications of a semiempirical formula for differential dose albedo for gamma rays on concrete, L. _____. Ingold. Port Hueneme, Calif., Nov. 1962.

12. _____. Technical Report R-228: A semiempirical formula for differential dose albedo for gamma rays on concrete, by A. B. Chilton and C. M. Huddleston. Port Hueneme, Calif., Nov. 1962.
13. _____. Technical Note N-465: Gamma-ray attenuation in a 12-inch-diameter round concrete duct, by T. R. Fowler and C. H. Dom. Port Hueneme, Calif., Nov. 1962.
14. _____. Technical Report R-195: Attenuation of gamma radiation in a two-legged 11-inch rectangular duct, by D. W. Green. Port Hueneme, Calif., May 1962.
15. Armour Research Foundation. Report ARF 1158A02-7: Radiation streaming in ducts and shelter entranceways, by C. W. Terrell et al. Chicago, Ill., April 1962.
16. U. S. Naval Civil Engineering Laboratory. Technical Note N-443: Gamma dose rates and energy spectra in a 3-foot square duct, by J. M. Chapman. Port Hueneme, Calif., June 1962.
17. _____. Technical Report R-325: Gamma-ray dose rates and energy spectra in a 3-foot square duct, by J. M. Chapman. Port Hueneme, Calif., 1964.
18. International Business Machines Corporation. IBM report 6.0.066: Stepwise regression analysis program (STRAP), an IBM-1620 computer program, by A. R. Colville and L. S. Holmes. White Plains, N. Y., Jan. 1962.

Appendix A

CHAPMAN'S COMPUTER CODE FOR COMPUTING GAMMA-RAY DOSE RATES IN TWO-LEGGED CONCRETE DUCTS

The computer code, written by J. M. Chapman,¹ which is used for numerous calculations in this report will now be briefly described. Because of the complexity of the problem and the limitations of the IBM-1620 computer, Chapman chose to divide his code into four separate programs. Each of these parts calculates one of the contributions to the total dose rate at the detector.

Early investigators found that when measuring dose rates in straight ducts, their readings were always 30 to 40 percent higher than could be explained by the inverse square law of dispersion of gamma particles from a point-isotropic source. This indicated that the photons were being backscattered from the walls of the duct. When this was studied analytically, it was determined that a single backscatter could not account for all of the build-up. This led to a realization that a second scatter contributed to the total dose.

In moving to a duct with a right-angle bend, another factor was found to materially affect attenuation. The lip at the inside corner of the bend was shown to produce an inscatter and to allow some radiation to pass through it uncollided, proceeding in a straight line until it reached the detector or a surface where it would undergo a backscatter. The albedo concept was developed to aid in the calculation of these scattering effects. Chapman incorporated differential dose albedo into his program, using the method of Chilton and Huddleston¹² to calculate each of the contributions to the total dose rate.

In the "corner-lip inscatter" (LC), the radiation which undergoes a backscatter and an uncollided penetration of the lip, in either order, is calculated, as well as that which reaches the detector as a result of a single inscatter through the corner lip. The contribution resulting from a backscatter and a lip inscatter, in either order, is calculated in the part, "multiple corner inscatter" (MC). That part of the total dose undergoing a single backscatter before reaching the detector, "primary corner areas incremented" (CI), is calculated by subdividing the scattering areas into smaller reflecting unit areas. The remainder of the total dose rate is handled in "multiple surface scatter" (MS), which treats all radiation that undergoes two backscatters.

For details concerning the physics of the computer code, the interested reader is referred to Reference 1.

The complete code, in five parts, is written for the IBM-1620 computer in Fortran I with format. The first four parts are used to calculate the different contributions of the problem while the fifth is merely a simple program to sum the output of the first four parts. Table A-I is a listing of the program which calculates the corner-lip inscatter (LC); Table A-II, the multiple corner inscatter (MC); Table A-III, the corner scattering areas incremented (CI); Table A-IV, the multiple surface scatter (MS); Table A-V, the summing program; Table A-VI, the ratio of each part to the total; Table A-VII, a sample problem showing input and output by parts.

The input format is in the form (F7.3, F6.0, 2F5.0, 3F5.1). The output identifies each case in the format (4 x F7.3, F6.0, 2F5.0, 3F5.1, 10H TOTAL (), 1 x E 12.4). If individual parts of any contribution are desired, sense switch 1 should be on. All dimensions are in inches.

TABLE A-1. CHAPMAN CODE LEDOUX-CHILTON LIP EFFECT

```

50 READ 100,EO,DO,EL1,EL2,W1,W2,H
100 FORMAT(F7.3,F6.0,F5.0,F5.0,F5.1,F5.1,F5.1)
    B1=W1/2.
    B2=W2/2.
    B3=H/2.
    X1=W1*W2/(2.*EL2-W1)
    X2=W1*W2/(2.*EL1-W2)
    IF(EO-.3)40,40,41
40 RLO=4.65/EO**.240
    GO TO 44
41 IF(EO-1.0)42,42,43
42 RLO=5.98
    GO TO 44
43 RLO=5.98*EO**.240
44 Y2=B1*(EL1+B2)/(EL1-B2-RLO)
    S2=B1*RLO/(EL1-B2-RLO)
    Z2=(Y2+B1+X2)/2.
    SQ3=EL1+B2
    SQ2=EL2+B1
    SQ1=(EL1*EL1+B1*B1)**.5
    SQ4=(EL2*EL2+B2*B2)**.5
    D=0.0
    J=4
    E=EO
    ANE=LOG(E)
    ANC=-2.921+.6805*ANE+.0111*ANE*ANE-.04131*ANE*ANE*ANE
    C=EXP(ANC)
    IF(E-1.)200,200,201
200 ANCP=-5.89+.275*(E-3.25)**2
    GO TO 204
201 IF(E-2.)202,203,203
202 ANCP=-4.86+.36*(E-2.)**2
    GO TO 204
203 ANCP=-4.83-.013*E
204 CP=EXP(ANCP)
    7 IF(J-4)8,8,9
    8 R1=(SQ3*SQ3+Z2*Z2)**.5
    R2=((EL2-Z2)**2+B2*B2)**.5
    CSTHO=(EL1+B2)/R1
    Csth=B2/R2
    CSPH=1.0
    AK=H*(Y2-X2-B1)
    GO TO 14

```

CONTINUED

```

9 IF(J-5)10,10,11
10 R1=(EL1*EL1+(B1+X2)**2+B3*B3)**.5
R2=((EL2-X2-B1)**2+B3*B3)**.5
CSTHO=B3/R1
CSTH=B3/R2
CSPH=(B1+X2)/((B1+X2)**2+EL1*EL1)**.5
AK=(Y2-B2)*(W2+RLO)-X2*W2-S2*RLO
GO TO 14
11 IF(J-6)12,12,13
12 R1=((EL1-B2-X1)**2+B1*B1)**.5
R2=((EL2+B1)**2+(B2+X1)**2)**.5
CSTHO=B1/R1
CSTH=(EL2+B2)/R2
CSPH=1.0
GO TO 14
16 IF(ES-.3)46,46,47
46 RLS=4.65/ES**.240
GO TO 51
47 IF(ES-1.0)48,48,49
48 RLS=5.98
GO TO 51
49 RLS=5.98*ES**.269
51 Y1=B2*(EL2+B1)/(EL2-B1-RLS)
AK=H*(Y1-X1-B2)
GO TO 23
13 IF(J-7)17,17,30
17 R1=((EL1-X1-B2)**2+B3*B3)**.5
R2=(EL2*EL2+(B2+X1)**2+B3*B3)**.5
CSTHO=B3/R1
CSTH=B3/R2
CSPH=(B2+X1)/((B2+X1)**2+EL2*EL2)**.5
GO TO 14
18 RLS=2.66*ES**.436
Y1=B2*(EL2+B1)/(EL2-B1-RLS)
S1=B2*RLS/(EL2-B1-RLS)
AK=(Y1-B1)*(W1+RLS)-X1*W1-S1*RLS
GO TO 23
14 STHO=(1.-CSTHO*CSTHO)**.5
STH=(1.-CSTH*CSTH)**.5
CSTHS=STHO*STH*CSPH-CSTHO*CSTH
29 ES=EO/(1.+EO/.511*(1.-CSTHS))
15 P=ES/EO
UK=3.9705*P*P*(1.+P*P-P*(1.-CSTHS**2))
IF(J-7)22,22,32
22 IF(J-6)23,16,18
23 AL=(C*UK+CP)/(1.+CSTHO/CSTH)
DK=DO*AK*AL*CSTHO/(R1*R2)**2
IF(SENSE SWITCH 1)6 .62

```

CONTINUED

```

61 IF(J-5)1000,1001,1002
1000 PUNCH 103,DK
103 FORMAT(E12.4,2X6HAREA 6)
GO TO 62
1001 PUNCH 105,DK
105 FORMAT(E12.4,2X6HAREA 8)
GO TO 62
1002 IF(J-6)1003,1003,1004
1003 PUNCH 106,DK
106 FORMAT(E12.4,2X6HAREA 5)
GO TO 62
1004 PUNCH 104,DK
104 FORMAT(E12.4,2X6HAREA 7)
GO TO 62
62 D=D+DK
J=J+1
GO TO 7
30 R1=((EL1-B2)**2+B1*B1)**.5
R2=((EL2-B1)**2+B2*B2)**.5
CSA1=B1/R1
CSA2=B2/R2
CSTHS=CSA1*(1.-CSA2*CSA2)**.5+CSA2*(1.-CSA1*CSA1)**.5
GO TO 29
32 DK=.01785*UK*H*CSA1*CSA2*RLO*RLO*DO/(R1*R2)**2
D=D+DK
IF (SENSE SWITCH 1)33,34
33 PUNCH 107,DK
107 FORMAT(E12.4,2X13HLIP INSCATTER)
34 PUNCH 102,E0,DO,EL1,EL2,W1,W2,H,D
102 FORMAT(4XF7.3,F6.0,2F5.0,3F5.1,10H TOTAL(LC),1XE12.4)
IF (SENSE SWITCH 2)77,88
77 PAUSE
88 GO TO 50
END

```

TABLE A-11. CHAPMAN CODE MULTIPLE CORNER INSCATTER

```

50 READ 100,E0,D0,EL1,EL2,W1,W2,H
100 FORMAT(F7.3,F6.0,F5.0,F5.0,F5.1,F5.1,F5.1)
    B1=W1/2.
    B2=W2/2.
    B3=H/2.
    EX1=W1*W2/(2.*EL2-W1)
    EX2=W1*W2/(2.*EL1-W2)
    DS=0.
    X0=EL1+B2
    Y0=B1
    Z0=0.
    X3=B2
    Y3=EL2+B1
    Z3=0.
    DO 99 I=1,3
    GO TO(1,2,3),I
1  X1=(EL1-B2)/2.+W2
    Y1=0.
    Z1=0.
    A=H*(EL1-B2)
    GO TO 4
2  X1=(EL1-B2)/2.+W2
    Y1=B1
    Z1=B3
    A=W1*(EL1-B2)*2.
    GO TO 4
3  X1=W2
    Y1=W1
    Z1=0.
4  DO 98 J=3,5
    J1=J-2
    GO TO(5,6,6),J1
5  IF(I-3)7,98,98
6  IF(I-3)98,7,98
7  GO TO(8,9,10),J1
8  X2=W2
    Y2=W1
    Z2=0.
    GO TO 12
9  X2=0.
    Y2=(EL2-B1)/2.+W1
    Z2=0.
    GO TO 12

```

CONTINUED

```

10 X2=B2
   Y2=(EL2-B1)/2.+W1
   Z2=B3
12 R1=SQRT((X0-X1)**2+(Y0-Y1)**2+(Z0-Z1)**2)
   R2=SQRT((X1-X2)**2+(Y1-Y2)**2+(Z1-Z2)**2)
   R3=SQRT((X3-X2)**2+(Y3-Y2)**2+(Z3-Z2)**2)
   GO TO(13,14,15),I
13 CS0=(Y0-Y1)/R1
   CS1=(Y1-Y2)/R2
   CSPH1=1.
   GO TO 16
14 CS0=(Z0-Z1)/R1
   CS1=(Z1-Z2)/R2
   CSPH1=(X1-X2)/SQRT((X1-X2)**2+(Y1-Y2)**2)
   GO TO 16
15 CS0=(X0-X1)/R1
   R=SQRT((X2-X1)**2+(Y2-Y1)**2)
   CS1=(Y2-Y1)/R
   CSPH1=R/R2
16 GO TO(17,18,19),J1
17 R=SQRT((X2-X1)**2+(Y2-Y1)**2)
   CS2=(Y2-Y1)/R
   CS3=(X3-X2)/R3
   CSPH2=R/R2
   GO TO 20
18 CS2=(X1-X2)/R2
   CS3=(X3-X2)/R3
   CSPH2=1.
   A=H*(EL2-B1)
   GO TO 20
19 CS2=(Z2-Z3)/R2
   CS3=(Z3-Z2)/R3
   CSPH2=(Y2-Y1)/SQRT((Y2-Y1)**2+(X1-X2)**2)
   A=W2*(EL2-B1)*2.
20 CS0=SQRT(CS0*CS0)
   CS1=SQRT(CS1*CS1)
   CS2=SQRT(CS2*CS2)
   CS3=SQRT(CS3*CS3)
   D1=D0
   K=1
   E1=E0
21 GO TO(22,23),K
22 IF(I-3)24,25,25
23 IF(J-3)25,25,24
25 CSTHS=CS0*SQRT(1.-CS1*CS1)+CS1*SQRT(1.-CS0*CS0)
   CSTHS=CSTHS*CSPH1
   GO TO 26

```

CONTINUED

```

24  STH0=SQRT(1.-CS0*CS0)
    STH=SQRT(1.-CS1*CS1)
    CSTHS=STH0*STH*CSPH1-CS0*CS1
26  ES1=E1/(1.+E1/.511*(1.-CSTHS))
    P=ES1/E1
    UK=3.9705*P*P*(1.+P*P-P*(1.-CSTHS**2))
    GO TO(27,28),K
27  IF(I-3)29,30,30
28  IF(J-3)30,30,29
30  IF(E1-.3)34,34,35
34  RLS=4.65/E1**.24
    GO TO 38
35  IF(E1-1.)36,36,37
36  RLS=5.98
    GO TO 38
37  RLS=5.98*E1**.24
38  D2=.01785*UK*H*CS0*CS1*RLS*RLS*D1/(R1*R2)**2
    GO TO 44
29  E=E1
    ANE=LOG(E)
    ANC=-2.921+.6805*ANE+.0111*ANE*ANE-.04131*ANE*ANE*ANE
    C=EXP(ANC)
    IF(E-1.)200,200,201
200 ANCP=-5.89+.275*(E-3.25)**2
    GO TO 204
201 IF(E-2.)202,203,203
202 ANCP=-4.86+.36*(E-2.)**2
    GO TO 204
203 ANCP=-4.83-.013*E
204 CP=EXP(ANCP)
43  AL=(C*UK+CP)/(1.+CS0/CS1)
    D2=D1*AL*A*CS0/(R1*R2)**2
44  IF(K-2)45,46,46
45  E1=ES1
    D1=D2*R2*R2
    R1=R2
    R2=R3
    CS0=CS2
    CS1=CS3
    CSPH1=CSPH2
    K=2
    GO TO 21
46  DS=DS+D2
    IF(SENSE SWITCH 1)47,98
47  PUNCH 101,I,J,D2
101 FORMAT(6X14,I4,E12.4)
98  CONTINUE

```

CONTINUED

```
99 CONTINUE
   PUNCH 102,E0,D0,EL1,EL2,W1,W2,H,DS
102 FORMAT(4XF7.3,F6.0,2F5.0,3F5.1,10H TOTAL(MC),1XE12.4)
   IF (SENSE SWITCH 2)77,88
77 PAUSE
88 GO TO 50
   END
```

TABLE A-III. PRIMARY CORNER AREAS INCREMENTED

```

READ 105, M
105 FORMAT (I2)
100 FORMAT(F7.3,F6.0,F5.0,F5.0,F5.1,F5.1,F5.1)
50 READ 100,E0,D0,EL1,EL2,W1,W2,H
   B1=W1/2.
   B2=W2/2.
   B3=H/2.
   EX1=W1*W2/(2.*EL2-W1)
   EX2=W1*W2/(2.*EL1-W2)
   E=E0
   ANE=LOG(E)
   ANC=-2.921+.6805*ANE+.0111*ANE*ANE-.04131*ANE*ANE*ANE
   C=EXP(ANC)
   IF(E-1.)200,200,201
200 ANCP=-5.89+.275*(E-3.25)**2
   GO TO 204
201 IF(E-2.)202,203,203
202 ANCP=-4.86+.36*(E-2.)**2
   GO TO 204
203 ANCP=-4.83-.013*E
204 CP=EXP(ANCP)
32 EM=M
   DZ=H/EM
   X1=EL1+B2
   Y1=B1
   Z1=B3
   X2=B2
   Y2=EL2+B1
   Z2=B3
   DC=0.
   DI=0.
   DO 40 K=1,5
   D=0.
   IF(K-1)20,20,21
20 DX=(W2+EX1)/EM
   X=-DX/2.
   DA=DX*DZ
   Y=0.
   GO TO 28
21 IF(K-2)22,22,23

```

CONTINUED

```

22 DY=(W1+EX2)/EM
    Y=-DY/2.
    DA=DY*DZ
    X=0.
    GO TO 28
23 IF(K-3)24,24,25
24 DX=W2/EM
    DY=W1/EM
    Y=-DY/2.
    Z=0.
    GO TO 28
25 IF(K-4)26,26,27
26 DX=EX1/EM
    DY=W1/EM
    Y=-DY/2.
    Z=0.
    GO TO 28
27 DX=W2/EM
    DY=EX2/EM
    X=-DX/2.
    Y=W1-DY/2.
    Z=0.
28 DO 39 I=1,M
    IF(K-1)1,1,2
    1 X=X+DX
      Z=-DZ/2.
      GO TO 5
    2 Y=Y+DY
      IF(K-2)3,3,4
    3 Z=-DZ/2.
      GO TO 5
    4 DA=DX*DY*2.
      IF(K-4)41,42,41
    41 X=-DX/2.
      GO TO 5
    42 X=W2-DX/2.
    5 DO 38 J=1,M
      IF(K-2)6,6,7
    6 Z=Z+DZ
      GO TO 8
    7 X=X+DX
      IF(K-3)8,8,13
    13 IF(J-M+I-1)8,15,38
    15 DA=DA/2.
    8 R1=SQRT((X1-X)**2+(Y1-Y)**2+(Z1-Z)**2)
      R2=SQRT((X2-X)**2+(Y2-Y)**2+(Z2-Z)**2)
      IF(K-1)9,9,10

```

CONTINUED

```

9  CSTH1=Y1/R1
   CSTH=Y2/R2
   A=SQRT((X1-X)**2+(Z1-Z)**2)
   B=SQRT((X2-X)**2+(Z2-Z)**2)
   CE=X1-X2
   GO TO 14
10 IF(K-2)11,11,12
11 CSTH1=X1/R1
   CSTH=X2/R2
   A=SQRT((Y1-Y)**2+(Z1-Z)**2)
   B=SQRT((Y2-Y)**2+(Z2-Z)**2)
   CE=Y2-Y1
   GO TO 14
12 CSTH1=Z1/R1
   CSTH=Z2/R2
   A=SQRT((X1-X)**2+(Y1-Y)**2)
   B=SQRT((X2-X)**2+(Y2-Y)**2)
   CE=SQRT((X1-X2)**2+(Y1-Y2)**2)
14 CSPH=(CE*CE-A*A-B*B)/(2.*A*B)
   STH1=SQRT(1.-CSTH1*CSTH1)
   STH=SQRT(1.-CSTH*CSTH)
   CSTHS=STH1*STH*CSPH-CSTH1*CSTH
   ES=E/(1.+E/.511*(1.-CSTHS))
   P=ES/E
   UK=3.9705*P*P*(1.+P*P-P*(1.-CSTHS**2))
   AL=(C*UK+CP)/(1.+CSTH1/CSTH)
   DK=DO*AL*DA*CSTH1/(R1*R2)**2
37 D=D+DK
38 CONTINUE
39 CONTINUE
   DI=DI+D
   IF(K-3)45,70,70
70 DC=DC+D
45 IF (SENSE SWITCH 1) 44,40
44 PUNCH 103,K,D
103 FORMAT(6X14,E12.4)
40 CONTINUE
   IF (SENSE SWITCH 1) 106,107
106 PUNCH 101,K,DC
101 FORMAT(6X14,E12.4,2X23H(TOTAL FOR AREAS 3,4,5))
107 PUNCH 102,E0,DO,EL1,EL2,W1,W2,H,DI
102 FORMAT(4XF7.3,F6.0,2F5.0,3F5.1,10H TOTAL(CI),1XE12.4)
   IF (SENSE SWITCH 2)77,88
77 PAUSE
88 GO TO 50
   END

```

TABLE A-IV. CHAPMAN CODE MULTIPLE SURFACE SCATTER

```

DIMENSION X(9),Y(9),Z(9),A(9),EM(9)
100 FORMAT(F7.3,F6.0,F5.0,F5.0,F5.1,F5.1,F5.1)
50 READ 100,E0,D0,EL1,EL2,W1,W2,H
    B1=W1/2.
    B2=W2/2.
    B3=H/2.
    EX1=W1*W2/(2.*EL2-W1)
    EX2=W1*W2/(2.*EL1-W2)
    S1=(EL1-EX1-B2)/2.+EX1+B2
    S2=(EL2-EX2-B1)/2.+EX2+B1
    PL1=(EL1-B2)/2.
    PL2=(EL2-B1)/2.
    S=W1/2.*W2/PL2
111 DM=0.
    X0=EL1+B2
    Y0=B1
    Z0=0.
    X3=B2
    Y3=EL2+B1
    Z3=0.
    X(1)=B2+S1
    X(2)=B2+S1
    X(3)=B2+PL1
    X(4)=B2
    X(5)=B2
    X(6)=0.
    X(7)=0.
    X(8)=B2
    X(9)=W2
    Y(1)=0.
    Y(2)=B1
    Y(3)=W1
    Y(4)=0.
    Y(5)=B1
    Y(6)=B1
    Y(7)=B1+S2
    Y(8)=B1+S2
    Y(9)=B1+PL2
    Z(1)=0.
    Z(2)=B3
    Z(3)=0.
    Z(4)=0.
    Z(5)=B3
    Z(6)=0.
    Z(7)=0.
    Z(8)=B3
    Z(9)=0.

```

CONTINUED

```

A(1)=2.*H*PL1-H*EX1
A(2)=4.*W1*PL1-W1*EX1
A(3)=2.*H*PL1
A(4)=H*(W2+EX1)
A(5)=2.*W1*W2+W1*EX1+W2*EX2
A(6)=H*(W1+EX2)
A(7)=2.*PL2*H-EX2*H
A(8)=4.*PL2*W2-EX2*W2
A(9)=2.*PL2*H
EM(1)=2.
EM(2)=3.
EM(3)=2.
EM(4)=2.
EM(5)=3.
EM(6)=1.
EM(7)=1.
EM(8)=3.
EM(9)=1.
DO 90 I=1,6
X1=X(I)
Y1=Y(I)
Z1=Z(I)
EM1=EM(I)
A1=A(I)
DO 89 J=4,9
IF(I-5)54,60,54
54 IF(I-J)55,89,60
55 IF(I-3)56,56,60
56 IF(J-7)60,114,89
114 IF(I-1)60,60,89
60 X2=X(J)
Y2=Y(J)
Z2=Z(J)
EM2=EM(J)
A2=A(J)
IF(I-1)115,115,112
115 IF(J-7)112,92,112
112 IF(J-5)66,62,61
92 X1=W2+S
A1=H*H
A2=(S-EX1)+W1*W2*LOG((EL1-B2)/S)
GO TO 66
61 IF(J-8)66,63,66
62 IF(I-2)66,64,63
63 IF(I-5)66,64,66
64 Z2=-Z2
A2=.5*A2

```

CONTINUED

```

66 R1=SQRT((X0-X1)**2+(Y0-Y1)**2+(Z0-Z1)**2)
R2=SQRT((X1-X2)**2+(Y1-Y2)**2+(Z1-Z2)**2)
R3=SQRT((X2-X3)**2+(Y2-Y3)**2+(Z2-Z3)**2)
IF(EM1-1.)67,67,68
67 CS0=(X0-X1)/R1
CS1=(X1-X2)/R2
CSPH1=0.
GO TO 71
68 IF(EM1-2.)69,69,70
69 CS0=(Y0-Y1)/R1
CS1=(Y1-Y2)/R2
CSPH1=(X1-X2)/((X1-X2)**2+(Z1-Z2)**2)**.5
GO TO 71
70 CS0=(Z0-Z1)/R1
CS1=(Z1-Z2)/R2
CSPH1=(X1-X2)/SQRT((X1-X2)**2+(Y1-Y2)**2)
71 IF(EM2-1.)72,72,73
72 CS2=(X1-X2)/R2
CS3=(X2-X3)/R3
CSPH2=(Y2-Y1)/SQRT((Y2-Y1)**2+(Z2-Z1)**2)
GO TO 76
73 IF(EM2-2.)74,74,75
74 CS2=(Y1-Y2)/R2
CS3=(Y2-Y3)/R3
CSPH2=0.
GO TO 76
75 CS2=(Z1-Z2)/R2
CS3=(Z2-Z3)/R3
CSPH2=(Y2-Y1)/SQRT((X1-X2)**2+(Y1-Y2)**2)
76 CS0=SQRT(CS0*CS0)
CS1=SQRT(CS1*CS1)
CS2=SQRT(CS2*CS2)
CS3=SQRT(CS3*CS3)
103 AA=A1
D1=D0
K=1
E1=E0
82 STH0=SQRT(1.-CS0*CS0)
STH=SQRT(1.-CS1*CS1)
CSTHS=STH0*STH*CSPH1-CS0*CS1
ES1=E1/(1.+E1/.511*(1.-CSTHS))
P=ES1/E1
UK=3.9705*P*P*(1.+P*P-P*(1.-CSTHS**2))
E=E1
ANE=LOG(E)
ANC=-2.921+.6805*ANE+.0111*ANE*ANE-.04131*ANE*ANE*ANE
C=EXP(ANC)
IF(E-1.)200,200,201

```

CONTINUED

```

200 ANCP=-5.89+.275*(E-3.25)**2
    GO TO 204
201 IF(E-2.)202,203,203
202 ANCP=-4.86+.36*(E-2.)**2
    GO TO 204
203 ANCP=-4.83-.013*E
204 CP=EXP(ANCP)
    79 AL=(C*UK+CP)/(1.+CS0/CS1)
      D2=D1*AL*AA*CS0/(R1*R2)**2
105 IF(K-2)80,81,81
    80 E1=ES1
      AA=A2
      D1=D2*R2*R2
      R1=R2
      R2=R3
      CS0=CS2
      CS1=CS3
      CSPH1=CSPH2
      K=2
      GO TO 82
    81 DM=DM+D2
      IF (SENSE SWITCH 1)83,89
    83 PUNCH 104,I,J,D2
104 FORMAT (6X14,I4,E12.4)
    89 CONTINUE
    90 CONTINUE
    91 PUNCH 102,E0,D0,EL1,EL2,W1,W2,H,DM
102 FORMAT(4XF7.3,F6.0,2F5.0,3F5.1,10H TOTAL(MS),1XE12.4)
      IF (SENSE SWITCH 2)77,88
    77 PAUSE
    88 GO TO 50
      END

```

TABLE A-V. PROGRAM TO TOTAL OUTPUT OF FOUR PARTS OF CHAPMAN CODE

```
READ 2,M,N
  2 FORMAT(I3,I2)
  PUNCH 500
500 FORMAT(15X40H CALCULATED DOSE RATES IN 2-LEGGED DUCTS/)
  PUNCH 600
600 FORMAT(2X28HLC=LEDOUX-CHILTON LIP EFFECT)
  PUNCH 700
700 FORMAT(2X28HMC=MULTIPLE CORNER INSCATTER)
  PUNCH 800
800 FORMAT(2X35HCI=PRIMARY CORNER AREAS INCREMENTED)
  PUNCH 900
900 FCRMAT(2X27HMS=MULTIPLE SURFACE SCATTER)
  PUNCH 400
400 FORMAT(6X,4H EO=,4X,4H DO=,20X13HCONTRIBUTIONS)
  PUNCH 1
  1 FORMAT(9X8HEL1 EL2,6X2HLC,9X2HMC,9X2HCI,9X2HMS,5X5HTOTAL)
  DO 55 I=1,M
  READ 300,W1,W2,H
300 FORMAT(I3,I3,I3)
  PUNCH 350,W1,W2,H
350 FORMAT(2X13,2H X,I3,2H X,I3)
  DO 44 J=1,N
  44 CONTINUE
  55 CONTINUE/
  PAUSE
  END
```

TABLE A-VI. RATIO OF EACH PART OF CHAPMAN CODE TO TOTAL

.662 MEV		LC	MC	CI	MS	CI+MS	LC+MC
EL1	EL2	12 X 12 CROSS SECTION					
48.	48.	.068	.471	.265	.194	.460	.339
48.	60.	.065	.421	.303	.210	.513	.486
48.	72.	.063	.370	.341	.224	.565	.433
60.	48.	.056	.477	.274	.192	.466	.539
60.	60.	.053	.426	.313	.206	.520	.479
60.	72.	.052	.374	.357	.220	.573	.426
72.	48.	.047	.487	.279	.185	.464	.535
72.	60.	.045	.435	.319	.198	.518	.481
72.	72.	.044	.383	.360	.211	.571	.428
12 X 24							
48.	48.	.059	.511	.222	.205	.427	.571
48.	60.	.053	.464	.243	.218	.462	.538
48.	72.	.051	.449	.268	.231	.499	.500
60.	48.	.048	.510	.229	.211	.440	.559
60.	60.	.043	.482	.250	.223	.474	.525
60.	72.	.048	.523	.322	.105	.427	.572
72.	48.	.041	.516	.233	.209	.442	.557
72.	60.	.036	.487	.254	.221	.475	.524
72.	72.	.035	.452	.278	.233	.512	.487
24 X 12							
48.	48.	.181	.390	.269	.159	.428	.571
48.	60.	.147	.380	.293	.178	.472	.527
48.	72.	.131	.353	.321	.193	.515	.485
60.	48.	.138	.388	.292	.180	.473	.526
60.	60.	.112	.369	.318	.199	.518	.482
60.	72.	.100	.337	.348	.213	.562	.437
72.	48.	.113	.386	.308	.190	.499	.500
72.	60.	.092	.363	.336	.207	.544	.456
72.	72.	.082	.328	.367	.221	.588	.411

CONTINUED

.662 MEV

	LC	MC	CI	MS	CI+MS	LC+MC
72 X 72						
288. 288.	.019	.142	.483	.353	.837	.162
288. 360.	.016	.118	.511	.352	.864	.135
288. 432.	.015	.096	.535	.352	.887	.112
360. 288.	.015	.143	.494	.346	.841	.159
360. 360.	.013	.118	.522	.344	.867	.132
360. 432.	.012	.096	.548	.342	.890	.109
432. 288.	.013	.146	.504	.334	.839	.160
432. 360.	.012	.121	.534	.332	.867	.133
432. 432.	.011	.099	.561	.328	.889	.110
72 X 144						
288. 288.	.017	.163	.425	.393	.819	.181
288. 360.	.015	.146	.442	.396	.838	.161
288. 432.	.013	.128	.460	.397	.857	.142
360. 288.	.014	.159	.430	.395	.826	.173
360. 360.	.012	.143	.446	.398	.844	.155
360. 432.	.014	.157	.617	.201	.818	.181
432. 288.	.012	.160	.436	.390	.827	.172
432. 360.	.010	.144	.452	.393	.845	.154
432. 432.	.009	.127	.470	.393	.863	.136
144 X 72						
288. 288.	.053	.124	.516	.305	.822	.178
288. 360.	.040	.113	.526	.319	.846	.154
288. 432.	.034	.099	.540	.326	.867	.133
360. 288.	.038	.115	.522	.323	.845	.154
360. 360.	.029	.103	.533	.333	.867	.132
360. 432.	.024	.088	.549	.337	.886	.113
432. 288.	.030	.110	.530	.327	.858	.141
432. 360.	.023	.097	.543	.335	.878	.121
432. 432.	.019	.083	.559	.337	.896	.103

CONTINUED

1.25 MEV		LC	MC	CI	MS	CI+MS	LC+MC
12 X 12							
48.	48.	.070	.444	.277	.207	.484	.515
48.	60.	.065	.401	.311	.221	.533	.466
48.	72.	.063	.354	.347	.234	.582	.417
60.	48.	.057	.447	.286	.209	.495	.504
60.	60.	.053	.402	.321	.222	.544	.455
60.	72.	.051	.354	.358	.235	.593	.406
72.	48.	.048	.455	.291	.203	.495	.504
72.	60.	.045	.410	.328	.216	.544	.455
72.	72.	.044	.361	.365	.228	.594	.405
12 X 24							
48.	48.	.062	.481	.237	.218	.455	.544
48.	60.	.055	.458	.256	.229	.485	.514
48.	72.	.052	.428	.279	.240	.519	.480
60.	48.	.050	.475	.245	.228	.473	.526
60.	60.	.044	.452	.263	.238	.502	.497
60.	72.	.042	.421	.286	.250	.536	.463
72.	48.	.042	.478	.249	.228	.478	.521
72.	60.	.037	.455	.267	.239	.506	.493
72.	72.	.035	.424	.290	.250	.540	.460
24 X 12							
48.	48.	.186	.383	.274	.156	.430	.569
48.	60.	.150	.375	.296	.177	.473	.526
48.	72.	.133	.350	.322	.193	.516	.483
60.	48.	.140	.375	.299	.184	.483	.516
60.	60.	.112	.359	.323	.204	.528	.472
60.	72.	.100	.328	.351	.220	.571	.428
72.	48.	.115	.368	.316	.199	.515	.484
72.	60.	.092	.348	.341	.217	.559	.440
72.	72.	.081	.315	.370	.232	.602	.397

CONTINUED

1.25 MEV

	LC	MC	CI	MS	CI+MS	LC+MC
72 X 72						
288. 288.	.018	.130	.487	.364	.851	.148
288. 360.	.016	.109	.510	.363	.874	.126
288. 432.	.015	.090	.533	.361	.894	.105
360. 288.	.015	.128	.494	.361	.856	.144
360. 360.	.013	.108	.519	.359	.878	.121
360. 432.	.012	.089	.542	.356	.898	.101
432. 288.	.013	.131	.503	.351	.855	.144
432. 360.	.011	.110	.528	.349	.878	.121
432. 432.	.010	.091	.553	.345	.898	.101
72 X 144						
288. 288.	.017	.147	.435	.400	.836	.164
288. 360.	.014	.133	.449	.402	.851	.148
288. 432.	.013	.119	.466	.401	.867	.132
360. 288.	.014	.141	.437	.406	.844	.155
360. 360.	.011	.128	.450	.408	.859	.140
360. 432.	.010	.114	.466	.407	.874	.125
432. 288.	.011	.141	.442	.404	.846	.153
432. 360.	.010	.129	.454	.406	.861	.139
432. 432.	.009	.114	.470	.405	.876	.123
144 X 72						
288. 288.	.054	.122	.524	.299	.823	.176
288. 360.	.040	.112	.530	.317	.847	.152
288. 432.	.034	.098	.542	.325	.867	.132
360. 288.	.038	.110	.526	.324	.851	.148
360. 360.	.028	.098	.534	.338	.872	.127
360. 432.	.024	.085	.547	.343	.890	.109
432. 288.	.030	.103	.531	.334	.866	.133
432. 360.	.023	.091	.540	.344	.885	.114
432. 432.	.019	.078	.553	.348	.902	.097

CONTINUED

6 MEV		LC	MC	CI	MS	CI+MS	LC+MC
12 X 12							
48.	48.	.097	.311	.363	.227	.591	.408
48.	60.	.089	.281	.394	.234	.628	.371
48.	72.	.086	.247	.428	.238	.666	.333
60.	48.	.076	.307	.372	.244	.616	.383
60.	60.	.070	.276	.402	.250	.653	.346
60.	72.	.067	.241	.435	.255	.691	.308
72.	48.	.063	.307	.375	.253	.628	.371
72.	60.	.058	.276	.405	.259	.665	.334
72.	72.	.055	.240	.438	.265	.703	.296
12 X 24							
48.	48.	.089	.336	.326	.247	.573	.426
48.	60.	.079	.324	.343	.253	.596	.403
48.	72.	.073	.302	.365	.258	.623	.376
60.	48.	.070	.327	.336	.266	.602	.397
60.	60.	.061	.314	.350	.272	.623	.376
60.	72.	.057	.293	.371	.277	.649	.350
72.	48.	.058	.324	.339	.278	.617	.382
72.	60.	.051	.312	.352	.284	.636	.363
72.	72.	.047	.289	.372	.289	.662	.337
24 X 12							
48.	48.	.231	.294	.323	.150	.473	.526
48.	60.	.189	.286	.352	.172	.524	.475
48.	72.	.167	.265	.380	.185	.566	.433
60.	48.	.170	.278	.363	.187	.551	.448
60.	60.	.138	.262	.390	.208	.598	.401
60.	72.	.122	.238	.418	.220	.639	.361
72.	48.	.137	.263	.386	.212	.599	.400
72.	60.	.110	.245	.411	.231	.643	.356
72.	72.	.097	.220	.438	.243	.681	.318

CONTINUED

6 MEV

	LC	MC	CI	MS	CI+MS	LC+MC
72 X 72						
288. 288.	.021	.078	.553	.346	.900	.099
288. 360.	.018	.068	.573	.340	.913	.086
288. 432.	.016	.057	.594	.331	.925	.074
360. 288.	.016	.075	.547	.360	.908	.091
360. 360.	.014	.064	.566	.353	.920	.079
360. 432.	.013	.054	.587	.345	.932	.067
432. 288.	.013	.074	.544	.267	.911	.088
432. 360.	.012	.064	.563	.360	.923	.076
432. 432.	.011	.053	.583	.352	.935	.064
72 X 144						
288. 288.	.019	.087	.508	.384	.893	.106
288. 360.	.016	.081	.518	.383	.901	.098
288. 432.	.015	.073	.533	.377	.911	.089
360. 288.	.015	.081	.503	.399	.903	.097
360. 360.	.013	.076	.512	.397	.910	.089
360. 432.	.012	.069	.526	.392	.918	.081
432. 288.	.012	.079	.499	.408	.908	.092
432. 360.	.011	.074	.506	.407	.914	.085
432. 432.	.010	.067	.519	.403	.922	.077
144 X 72						
288. 288.	.057	.088	.583	.271	.854	.145
288. 360.	.043	.079	.588	.288	.876	.123
288. 432.	.036	.069	.600	.293	.894	.106
360. 288.	.039	.074	.584	.301	.885	.114
360. 360.	.030	.066	.589	.314	.903	.096
360. 432.	.025	.057	.600	.317	.917	.082
432. 288.	.030	.066	.582	.320	.903	.096
432. 360.	.023	.058	.587	.330	.917	.082
432. 432.	.019	.050	.598	.331	.929	.070

CONTINUED

TABLE A-VII. SAMPLE PROBLEM SHOWING OUTPUT BY PARTS

.8046E-03	AREA 6								
.8094E-03	AREA 8								
.5162E-02	AREA 5								
.2719E-02	AREA 7								
.1783E-01	LIP INSCATTER								
1.250	4910.	90.	36.	36.0	36.0	36.0	TOTAL (LC)		.2732E-01
1	3	.4383E-02							
2	3	.5254E-02							
3	4	.4135E-03							
3	5	.7849E-03							
1.250	4910.	90.	36.	36.0	36.0	36.0	TOTAL (MC)		.1083E-01
1	4	.0000E-50							
1	5	.3058E-03							
1	6	.1288E-03							
1	7	.2378E-04							
2	4	.3266E-03							
2	5	.6258E-03							
2	6	.3686E-03							
3	4	.2223E-03							
3	5	.5204E-03							
3	6	.2199E-03							
4	5	.4408E-03							
4	6	.3397E-03							
4	7	.3267E-04							
4	8	.8328E-04							
4	9	.6107E-04							
5	4	.2674E-03							
5	5	.1545E-03							
5	6	.3675E-03							
5	7	.1031E-03							
5	8	.1246E-03							
5	9	.1119E-03							
6	4	.1840E-03							
6	5	.3550E-03							
6	7	.0000E-50							
6	8	.1318E-03							
6	9	.5919E-04							
1.250	4910.	90.	36.	36.0	36.0	36.0	TOTAL (MS)		.5559E-02
1	.4421E-02								
2	.3943E-02								
3	.4062E-02								
4	.3897E-02								
5	.9817E-03								
6	.8941E-02	(TOTAL FOR AREAS 3,4,5)							
1.250	4910.	90.	36.	36.0	36.0	36.0	TOTAL (CI)		.1730E-01

Appendix B

COMPARISON OF THE EMPIRICAL FORMULA WITH OTHER COMPUTATIONAL TECHNIQUES

LC = LeDoux-Chilton lip inscatter

MC = Multiple comer inscatter

CI = Primary comer areas incremented

MS = Multiple surface scatter

RI = Dose attenuation factor as computed by the empirical formula

RC = Dose attenuation factor as computed by the Chapman Code

R = RI/RC

TABLE B-I. CALCULATED DOSE RATES IN TWO-LEGGED DUCTS

E0=.662		D0=1		(AT 1 INCH)		ALL DIMENSIONS IN INCHES				
EL1	EL2	LC	MC	CI	MS	TOTAL				
12 X 12		CROSS SECTION								
48.	48.	.9940E-07	.6798E-06	.3838E-06	.2807E-06	.1443E-05				
48.	60.	.4704E-07	.3045E-06	.2194E-06	.1519E-06	.7228E-06				
48.	72.	.2595E-07	.1509E-06	.1392E-06	.9147E-07	.4076E-06				
60.	48.	.4484E-07	.3812E-06	.2194E-06	.1535E-06	.7989E-06				
60.	60.	.2128E-07	.1707E-06	.1256E-06	.8285E-07	.4004E-06				
60.	72.	.1176E-07	.8458E-07	.7981E-07	.4973E-07	.2258E-06				
72.	48.	.2387E-07	.2430E-06	.1392E-06	.9238E-07	.4985E-06				
72.	60.	.1134E-07	.1088E-06	.7981E-07	.4964E-07	.2496E-06				
72.	72.	.6277E-08	.5392E-07	.5069E-07	.2967E-07	.1405E-06				
12 X 24										
48.	48.	.1902E-06	.1624E-05	.7051E-06	.6523E-06	.3172E-05				
48.	60.	.9064E-07	.8144E-06	.4098E-06	.3676E-06	.1682E-05				
48.	72.	.5020E-07	.4400E-06	.2626E-06	.2265E-06	.9793E-06				
60.	48.	.8671E-07	.9113E-06	.4098E-06	.3765E-06	.1784E-05				
60.	60.	.4138E-07	.4583E-06	.2382E-06	.2126E-06	.9505E-06				
60.	72.	.2296E-07	.2479E-06	.1526E-06	.1311E-06	.5546E-06				
72.	48.	.4643E-07	.5803E-06	.2626E-06	.2350E-06	.1124E-05				
72.	60.	.2218E-07	.2926E-06	.1526E-06	.1327E-06	.6001E-06				
72.	72.	.1231E-07	.1584E-06	.9772E-07	.8181E-07	.3503E-06				
24 X 12										
48.	48.	.1310E-05	.2825E-05	.1950E-05	.1151E-05	.7236E-05				
48.	60.	.5228E-06	.1348E-05	.1041E-05	.6329E-06	.3545E-05				
48.	72.	.2589E-06	.6951E-06	.6324E-06	.3815E-06	.1967E-05				
60.	48.	.4918E-06	.1383E-05	.1041E-05	.6433E-06	.3559E-05				
60.	60.	.1993E-06	.6560E-06	.5658E-06	.3538E-06	.1774E-05				
60.	72.	.9991E-07	.3364E-06	.3478E-06	.2135E-06	.9977E-06				
72.	48.	.2325E-06	.7921E-06	.6324E-06	.3904E-06	.2047E-05				
72.	60.	.9576E-07	.3758E-06	.3478E-06	.2149E-06	.1034E-05				
72.	72.	.4832E-07	.1926E-06	.2153E-05	.1297E-06	.5859E-06				

CONTINUED

EO=.662 DO=36

	EL1	EL2	LC	MC	CI	MS	TOTAL
72 X 72	DO=36						
	288.	288.	.1531E-07	.1133E-06	.3838E-06	.2807E-06	.7931E-06
	288.	360.	.7275E-08	.5075E-07	.2194E-06	.1519E-06	.4293E-06
	288.	432.	.4020E-08	.2516E-07	.1392E-06	.9147E-07	.2598E-06
	360.	288.	.7002E-08	.6353E-07	.2194E-06	.1535E-06	.4434E-06
	360.	360.	.3338E-08	.2845E-07	.1256E-06	.8285E-07	.2402E-06
	360.	432.	.1849E-08	.1409E-07	.7981E-07	.4973E-07	.1454E-06
	432.	288.	.3756E-08	.4051E-07	.1392E-06	.9238E-07	.2758E-06
	432.	360.	.1793E-08	.1814E-07	.7981E-07	.4264E-07	.1493E-06
	432.	432.	.9955E-09	.8986E-08	.5069E-07	.2967E-07	.9034E-07
72 X 144							
	288.	288.	.2935E-07	.2707E-06	.7051E-06	.6523E-06	.1657E-05
	288.	360.	.1403E-07	.1357E-06	.4098E-06	.3676E-06	.9271E-06
	288.	432.	.7788E-08	.7334E-07	.2626E-06	.2265E-06	.5702E-06
	360.	288.	.1354E-07	.1518E-06	.4098E-06	.3765E-06	.9517E-06
	360.	360.	.6495E-08	.7639E-07	.2382E-06	.2126E-06	.5336E-06
	360.	432.	.3612E-08	.4133E-07	.1526E-06	.1311E-06	.3286E-06
	432.	288.	.7307E-08	.9672E-07	.2626E-06	.2350E-06	.6016E-06
	432.	360.	.3508E-08	.4877E-07	.1526E-06	.1327E-06	.3375E-06
	432.	432.	.1953E-08	.2641E-07	.9772E-07	.8181E-07	.2078E-06
144 X 72							
	288.	288.	.2009E-06	.4708E-06	.1950E-05	.1151E-05	.3772E-05
	288.	360.	.8029E-07	.2247E-06	.1041E-05	.6329E-06	.1978E-05
	288.	432.	.5979E-07	.1158E-06	.6324E-06	.3815E-06	.1169E-05
	360.	288.	.7680E-07	.2306E-06	.1041E-05	.6433E-06	.1991E-05
	360.	360.	.3122E-07	.1093E-06	.5658E-06	.3538E-06	.1060E-05
	360.	432.	.1566E-07	.5608E-07	.3478E-06	.2135E-06	.6330E-06
	432.	288.	.3668E-07	.1320E-06	.6324E-06	.3904E-06	.1191E-05
	432.	360.	.1514E-07	.6264E-07	.3478E-06	.2149E-06	.6404E-06
	432.	432.	.7659E-08	.3210E-07	.2153E-06	.1297E-06	.3847E-06

CONTINUED

EO=1.25		DO=1.		(AT 1 INCH)		ALL DIMENSIONS IN INCHES				
EL1	EL2	LC	MC	CI	MS	TOTAL				
12 X 12		CROSS SECTION								
48.	48.	.6210E-07	.3915E-06	.2443E-06	.1826E-06	.8805E-06				
48.	60.	.2946E-07	.1798E-06	.1396E-06	.9945E-07	.4483E-06				
48.	72.	.1628E-07	.9042E-07	.8862E-07	.5999E-07	.2553E-06				
60.	48.	.2787E-07	.2179E-06	.1396E-06	.1019E-06	.4873E-06				
60.	60.	.1324E-07	.1001E-06	.8004E-07	.5543E-07	.2488E-06				
60.	72.	.7333E-08	.5032E-07	.5084E-07	.3338E-07	.1418E-06				
72.	48.	.1479E-07	.1383E-06	.8862E-07	.6191E-07	.3036E-06				
72.	60.	.7035E-08	.6361E-07	.5084E-07	.3358E-07	.1550E-06				
72.	72.	.3898E-08	.3193E-07	.3231E-07	.2016E-07	.8830E-07				
12 X 24										
48.	48.	.1176E-06	.9043E-06	.4459E-06	.4103E-06	.1878E-05				
48.	60.	.5629E-07	.4643E-06	.2595E-06	.2323E-06	.1012E-05				
48.	72.	.3127E-07	.2552E-06	.1664E-06	.1433E-06	.5962E-06				
60.	48.	.5347E-07	.5031E-06	.2595E-06	.2412E-06	.1057E-05				
60.	60.	.2560E-07	.2594E-06	.1511E-06	.1369E-06	.5730E-06				
60.	72.	.1423E-07	.1428E-06	.9690E-07	.8470E-07	.3386E-06				
72.	48.	.2859E-07	.3187E-06	.1664E-06	.1522E-06	.6659E-06				
72.	60.	.1368E-07	.1649E-06	.9690E-07	.8656E-07	.3620E-06				
72.	72.	.7615E-08	.9091E-07	.6211E-07	.5354E-07	.2141E-06				
24 X 12										
48.	48.	.8555E-06	.1760E-05	.1259E-05	.7197E-06	.4594E-05				
48.	60.	.3388E-06	.8486E-06	.6693E-06	.4005E-06	.2257E-05				
48.	72.	.1676E-06	.4402E-06	.4054E-06	.2432E-06	.1256E-05				
60.	48.	.3146E-06	.8409E-06	.6693E-06	.4128E-06	.2237E-05				
60.	60.	.1266E-06	.4027E-06	.3627E-06	.2296E-06	.1121E-05				
60.	72.	.6338E-07	.2080E-06	.2225E-06	.1396E-06	.6335E-06				
72.	48.	.1483E-06	.4721E-06	.4054E-06	.2550E-06	.1280E-05				
72.	60.	.6028E-07	.2268E-06	.2225E-06	.1420E-06	.6515E-06				
72.	72.	.3037E-07	.1171E-06	.1375E-06	.8644E-07	.3714E-06				

CONTINUED

EO=1.25 DO=36

EL1	EL2	LC	MC	CI	MS	TOTAL
72 X 72	DO=36					
288.	288.	.9484E-08	.6525E-07	.2443E-06	.1826E-06	.5016E-06
288.	360.	.4512E-08	.2997E-07	.1396E-06	.9944E-07	.2735E-06
288.	432.	.2497E-08	.1507E-07	.8862E-07	.5999E-07	.1661E-06
360.	288.	.4324E-08	.3633E-07	.1396E-06	.1019E-06	.2821E-06
360.	360.	.2063E-08	.1669E-07	.8004E-07	.5542E-07	.1542E-06
360.	432.	.1145E-08	.8387E-08	.5084E-07	.3338E-07	.9375E-07
432.	288.	.2315E-08	.2306E-07	.8862E-07	.6191E-07	.1759E-06
432.	360.	.1106E-08	.1060E-07	.5084E-07	.3357E-07	.9611E-07
432.	432.	.6149E-09	.5322E-08	.3231E-07	.2016E-07	.5840E-07
72 X 144						
288.	288.	.1800E-07	.1507E-06	.4459E-06	.4102E-06	.1024E-05
288.	360.	.8635E-08	.7739E-07	.2595E-06	.2323E-06	.5778E-06
288.	432.	.4804E-08	.4253E-07	.1664E-06	.1433E-06	.3570E-06
360.	288.	.8302E-08	.8385E-07	.2595E-06	.2412E-06	.5928E-06
360.	360.	.3991E-08	.4324E-07	.1511E-06	.1369E-06	.3352E-06
360.	432.	.2224E-08	.2381E-07	.9690E-07	.8469E-07	.2076E-06
432.	288.	.4477E-08	.5312E-07	.1664E-06	.1522E-06	.3762E-06
432.	360.	.2154E-08	.2748E-07	.9690E-07	.8655E-07	.2130E-06
432.	432.	.1201E-08	.1515E-07	.6211E-07	.5353E-07	.1319E-06
144 X 72						
288.	288.	.1300E-06	.2933E-06	.1259E-05	.7194E-06	.2401E-05
288.	360.	.5145E-07	.1414E-06	.6693E-06	.4004E-06	.1262E-05
288.	432.	.2543E-07	.7336E-07	.4054E-06	.2431E-06	.7472E-06
360.	288.	.4884E-07	.1401E-06	.6693E-06	.4127E-06	.1271E-05
360.	360.	.1968E-07	.6712E-07	.3627E-06	.2296E-06	.6791E-06
360.	432.	.9858E-08	.3467E-07	.2225E-06	.1396E-06	.4066E-06
432.	288.	.2326E-07	.7868E-07	.4054E-06	.2549E-06	.7622E-06
432.	360.	.9482E-08	.3780E-07	.2225E-06	.1420E-06	.4117E-06
432.	432.	.4784E-08	.1953E-07	.1375E-06	.8643E-07	.2482E-06

CONTINUED

EO=6		DO=1. (AT 1 INCH)		ALL DIMENSIONS IN INCHES			
EL1	EL2	LC	MC	CI	MS	TOTAL	
12 X 12		CROSS SECTION					
48.	48.	.2743E-07	.8712E-07	.1018E-06	.6375E-07	.2801E-06	
48.	60.	.1325E-07	.4159E-07	.5819E-07	.3452E-07	.1475E-06	
48.	72.	.7418E-08	.2131E-07	.3693E-07	.2058E-07	.8624E-07	
60.	48.	.1198E-07	.4802E-07	.5819E-07	.3827E-07	.1564E-06	
60.	60.	.5810E-08	.2291E-07	.3332E-07	.2078E-07	.8282E-07	
60.	72.	.3262E-08	.1171E-07	.2116E-07	.1243E-07	.4856E-07	
72.	48.	.6248E-08	.3028E-07	.3693E-07	.2493E-07	.9839E-07	
72.	60.	.3034E-08	.1444E-07	.2116E-07	.1356E-07	.5219E-07	
72.	72.	.1706E-08	.7374E-08	.1344E-07	.8124E-08	.3064E-07	
12 X 24							
48.	48.	.5131E-07	.1928E-06	.1873E-06	.1416E-06	.5730E-06	
48.	60.	.2506E-07	.1028E-06	.1088E-06	.8045E-07	.3171E-06	
48.	72.	.1412E-07	.5786E-07	.6974E-07	.4935E-07	.1910E-06	
60.	48.	.2275E-07	.1058E-06	.1088E-06	.8621E-07	.3235E-06	
60.	60.	.1114E-07	.5672E-07	.6324E-07	.4910E-07	.1807E-06	
60.	72.	.6292E-08	.3192E-07	.4050E-07	.3021E-07	.1089E-06	
72.	48.	.1197E-07	.6666E-07	.6974E-07	.5714E-07	.2055E-06	
72.	60.	.5866E-08	.3582E-07	.4050E-07	.3262E-07	.1148E-06	
72.	72.	.3316E-08	.2016E-07	.2593E-07	.2012E-07	.6952E-07	
24 X 12							
48.	48.	.3687E-06	.4700E-06	.5155E-06	.2400E-06	.1594E-05	
48.	60.	.1478E-06	.2240E-06	.2752E-06	.1347E-06	.7117E-06	
48.	72.	.7385E-07	.1169E-06	.1673E-06	.8180E-07	.4398E-06	
60.	48.	.1292E-06	.2106E-06	.2752E-06	.1418E-06	.7568E-06	
60.	60.	.5317E-07	.1007E-06	.1497E-06	.7974E-07	.3833E-06	
60.	72.	.2703E-07	.5248E-07	.9207E-07	.4860E-07	.2201E-06	
72.	48.	.5934E-07	.1139E-06	.1673E-06	.9203E-07	.4326E-06	
72.	60.	.2476E-07	.5496E-07	.9207E-07	.5179E-07	.2205E-06	
72.	72.	.1271E-07	.2875E-07	.5703E-07	.3163E-07	.1301E-06	

CONTINUED

EO=6 DO=0

	EL1	EL2	LC	MC	CI	MS	TOTAL
72 X 72	DO=0						
	288.	288.	.3869E-08	.1452E-07	.1018E-06	.6374E-07	.1839E-06
	288.	360.	.1876E-08	.6932E-08	.5819E-07	.3452E-07	.1015E-06
	288.	432.	.1051E-08	.3553E-08	.3693E-07	.2058E-07	.6211E-07
	360.	288.	.1756E-08	.8004E-08	.5819E-07	.3827E-07	.1062E-06
	360.	360.	.8552E-09	.3818E-08	.3332E-07	.2078E-07	.5877E-07
	360.	432.	.4812E-09	.1952E-08	.2116E-07	.1243E-07	.3602E-07
	432.	288.	.9358E-09	.5048E-08	.3693E-07	.2493E-07	.6784E-07
	432.	360.	.4568E-09	.2406E-08	.2116E-07	.1356E-07	.3758E-07
	432.	432.	.2575E-09	.1229E-08	.1344E-07	.8124E-08	.2305E-07
72 X 144							
	288.	288.	.7245E-08	.3213E-07	.1873E-06	.1416E-06	.3682E-06
	288.	360.	.3552E-08	.1713E-07	.1088E-06	.8044E-07	.2099E-06
	288.	432.	.2005E-08	.9643E-08	.6974E-07	.4935E-07	.1307E-06
	360.	288.	.3336E-08	.1763E-07	.1088E-06	.8620E-07	.2159E-06
	360.	360.	.1640E-08	.9454E-08	.6324E-07	.4909E-07	.1234E-06
	360.	432.	.9288E-09	.5320E-08	.4050E-07	.3021E-07	.7695E-07
	432.	288.	.1793E-08	.1111E-07	.6974E-07	.5713E-07	.1397E-06
	432.	360.	.8832E-09	.5970E-08	.4050E-07	.3262E-07	.7997E-07
	432.	432.	.5007E-09	.3360E-08	.2593E-07	.2012E-07	.4991E-07
144 X 72							
	288.	288.	.5055E-07	.7833E-07	.5155E-06	.2399E-06	.8842E-06
	288.	360.	.2024E-07	.3733E-07	.2752E-06	.1347E-06	.4674E-06
	288.	432.	.1011E-07	.1948E-07	.1673E-06	.8179E-07	.2786E-06
	360.	288.	.1871E-07	.3511E-07	.2752E-06	.1417E-06	.4707E-06
	360.	360.	.7705E-08	.1679E-07	.1497E-06	.7070E-07	.2539E-06
	360.	432.	.3920E-08	.8747E-08	.9207E-07	.4860E-07	.1533E-06
	432.	288.	.8830E-08	.1899E-07	.1673E-06	.9204E-07	.2871E-06
	432.	360.	.3695E-08	.9160E-08	.9207E-07	.5178E-07	.1567E-06
	432.	432.	.1900E-08	.4792E-08	.5703E-07	.3162E-07	.9534E-07

TABLE B-11. FORMULA SOLUTIONS IN 120 CASES

A. SIXTY EXPERIMENTAL CASES

E0	L1	L2	H	W	RI	RC	R
1.250	1.740	1.510	.917	.917	.1166E-01	.1829E-01	.637
1.250	1.740	1.890	.917	.917	.6411E-02	.9216E-02	.695
1.250	1.740	2.250	.917	.917	.4027E-02	.5613E-02	.717
1.250	1.740	3.370	.917	.917	.1371E-02	.1752E-02	.782
1.250	3.280	1.890	.917	.917	.1286E-02	.1278E-02	1.006
1.250	3.280	2.620	.917	.917	.5382E-03	.5406E-03	.995
1.250	3.280	3.370	.917	.917	.2750E-03	.2693E-03	1.021
1.250	3.270	1.600	.925	.925	.2071E-02	.2042E-02	1.014
1.250	3.270	2.580	.925	.925	.5794E-03	.5798E-03	.999
1.250	3.270	3.250	.925	.925	.3130E-03	.3110E-03	1.006
1.250	8.000	11.000	6.000	6.000	.2657E-03	.2955E-03	.899
1.250	8.000	15.000	6.000	6.000	.1161E-03	.1259E-03	.922
1.250	8.000	19.000	6.000	6.000	.6185E-04	.6658E-04	.929
1.250	6.000	5.000	3.000	3.000	.6195E-03	.6029E-03	1.027
1.250	6.000	6.000	3.000	3.000	.3809E-03	.3688E-03	1.033
1.250	6.000	7.000	3.000	3.000	.2525E-03	.2444E-03	1.033
1.250	7.500	4.500	3.000	3.000	.4661E-03	.4244E-03	1.098
1.250	7.500	5.500	3.000	3.000	.2729E-03	.2464E-03	1.107
1.250	7.500	6.000	3.000	3.000	.2164E-03	.1961E-03	1.103
1.250	7.500	7.500	3.000	3.000	.1193E-03	.1109E-03	1.076
1.250	10.000	11.000	6.000	6.000	.1509E-03	.1506E-03	1.002
1.250	10.000	15.000	6.000	6.000	.6600E-04	.6639E-04	.994
1.250	10.000	19.000	6.000	6.000	.3513E-04	.3550E-04	.989
1.250	12.000	11.000	6.000	6.000	.9510E-04	.9038E-04	1.052
1.250	12.000	15.000	6.000	6.000	.4158E-04	.4068E-04	1.022
1.250	12.000	19.000	6.000	6.000	.2213E-04	.2188E-04	1.011
1.250	3.500	2.000	1.000	1.000	.1202E-02	.1290E-02	.932
1.250	3.500	3.000	1.000	1.000	.4078E-03	.4465E-03	.913
1.250	3.500	4.000	1.000	1.000	.1893E-03	.1972E-03	.960
.662	3.500	2.000	1.000	1.000	.1888E-02	.2202E-02	.857
.662	3.500	3.000	1.000	1.000	.6404E-03	.7588E-03	.843
.662	3.500	4.000	1.000	1.000	.2973E-03	.3270E-03	.909
.662	13.000	11.000	6.000	6.000	.1219E-03	.1326E-03	.919
.662	13.000	14.000	6.000	6.000	.6408E-04	.7158E-04	.895
.662	12.000	11.000	6.000	6.000	.1493E-03	.1663E-03	.898
.662	12.000	19.000	6.000	6.000	.3476E-04	.4012E-04	.866
.412	10.000	11.000	6.000	6.000	.3319E-03	.3367E-03	.985
.412	10.000	15.000	6.000	6.000	.1451E-03	.1512E-03	.960
.412	10.000	19.000	6.000	6.000	.7727E-04	.7808E-04	.989
.412	13.000	11.000	6.000	6.000	.1707E-03	.1664E-03	1.026
.412	13.000	15.000	6.000	6.000	.7466E-04	.7515E-04	.993
.412	13.000	19.000	6.000	6.000	.3974E-04	.3992E-04	.995

CONTINUED

E0	L1	L2	H	W	RI	RC	R
1.370	10.000	11.000	6.000	6.000	.1414E-03	.1419E-03	.996
2.750	10.000	11.000	6.000	6.000	.8624E-04	.9269E-04	.930
1.370	10.000	15.000	6.000	6.000	.6184E-04	.6270E-04	.986
2.750	10.000	15.000	6.000	6.000	.3771E-04	.4020E-04	.938
1.370	10.000	19.000	6.000	6.000	.3292E-04	.3337E-04	.986
2.750	10.000	19.000	6.000	6.000	.2007E-04	.2153E-04	.932
1.370	13.000	11.000	6.000	6.000	.7275E-04	.6832E-04	1.064
2.750	13.000	11.000	6.000	6.000	.4435E-04	.4349E-04	1.019
1.370	13.000	15.000	6.000	6.000	.3181E-04	.3082E-04	1.032
2.750	13.000	15.000	6.000	6.000	.1939E-04	.1955E-04	.992
1.370	13.000	19.000	6.000	6.000	.1693E-04	.1663E-04	1.018
2.750	13.000	19.000	6.000	6.000	.1032E-04	.1061E-04	.973
1.370	17.000	11.000	6.000	6.000	.3686E-04	.3307E-04	1.114
2.750	17.000	11.000	6.000	6.000	.2247E-04	.2109E-04	1.065
1.370	17.000	15.000	6.000	6.000	.1612E-04	.1532E-04	1.052
2.750	17.000	15.000	6.000	6.000	.9829E-05	.9664E-05	1.017
1.370	17.000	19.000	6.000	6.000	.8581E-05	.8363E-05	1.026
2.750	17.000	19.000	6.000	6.000	.5232E-05	.4547E-05	1.150

CONTINUED

B. SIXTY RANDOM CASES

EO	L1	L2	H	W	RI	RC	R
1.234	11.000	18.000	5.200	4.800	.1825E-04	.1761E-04	1.036
1.995	21.000	15.000	6.000	3.200	.2111E-05	.2183E-05	.967
.732	30.000	20.000	5.900	4.300	.1421E-05	.1388E-05	1.023
1.035	22.000	25.000	4.800	4.500	.1219E-05	.1099E-05	1.109
.977	16.000	17.000	4.100	3.000	.3120E-05	.2818E-05	1.107
2.519	17.000	15.000	5.500	4.600	.5747E-05	.5663E-05	1.014
4.323	23.000	17.000	6.000	3.400	.7810E-06	.8593E-06	.908
5.057	7.000	7.000	5.000	2.900	.9422E-04	.8941E-04	1.053
1.962	17.000	17.000	5.000	3.100	.2082E-05	.2058E-05	1.011
3.252	20.000	20.000	3.700	2.900	.4172E-06	.2997E-06	1.043
5.972	31.000	10.000	6.000	4.800	.2356E-05	.2215E-05	1.063
2.275	23.000	31.000	5.200	5.100	.4819E-06	.4700E-06	1.025
4.702	22.000	32.000	5.900	3.100	.1252E-06	.1381E-06	.907
3.676	17.000	25.000	4.700	4.300	.8551E-06	.8442E-06	1.012
4.384	19.000	8.000	4.200	2.200	.2891E-05	.2966E-05	.975
5.523	18.000	19.000	4.300	4.300	.1062E-05	.1076E-05	.987
3.809	6.000	5.000	4.000	2.100	.1814E-03	.1668E-03	1.087
3.633	13.000	8.000	4.300	3.600	.2315E-04	.1946E-04	1.189
2.992	30.000	24.000	5.900	4.000	.2791E-06	.2975E-06	.938
2.990	29.000	25.000	5.100	2.600	.1029E-06	.1078E-06	.954
4.411	29.000	31.000	5.400	4.400	.1297E-06	.1380E-06	.940
3.701	7.000	22.000	4.000	3.000	.4841E-05	.4464E-05	1.084
5.299	10.000	6.000	1.700	1.100	.3139E-05	.3077E-05	1.020
4.308	33.000	27.000	5.700	5.100	.1927E-06	.2090E-06	.922
4.715	25.000	15.000	5.200	4.000	.1002E-05	.1047E-05	.957
2.305	16.000	12.000	5.100	3.900	.8749E-05	.8292E-05	1.055
5.859	22.000	23.000	4.800	4.600	.4642E-06	.4859E-06	.955
3.408	12.000	7.000	2.400	1.900	.7148E-05	.6714E-05	1.064
3.531	9.000	11.000	2.800	1.700	.4004E-05	.3808E-05	1.051
4.323	14.000	12.000	2.900	2.900	.2635E-05	.2485E-05	1.060
4.707	16.000	13.000	5.400	3.600	.3833E-05	.3848E-05	.996
2.381	22.000	20.000	6.000	4.600	.1563E-05	.1600E-05	.977
5.960	2.000	6.000	1.100	1.000	.9536E-04	.1049E-03	.909
5.142	5.000	4.000	2.300	1.200	.8544E-04	.8117E-04	1.052
2.712	30.000	16.000	5.700	4.100	.8977E-06	.9265E-06	.968
.715	30.000	19.000	5.200	3.700	.1100E-05	.1052E-05	1.046
5.971	25.000	16.000	4.200	2.400	.2175E-06	.2372E-06	.917
3.171	22.000	17.000	5.900	4.900	.2193E-05	.2238E-05	.980
.845	28.000	30.000	5.000	3.300	.2657E-06	.2370E-06	1.121
3.780	24.000	14.000	5.100	3.000	.8743E-06	.9374E-06	.932
2.269	7.000	14.000	2.400	2.000	.6509E-05	.5495E-05	1.184
4.891	17.000	33.000	5.700	4.100	.3613E-06	.3715E-06	.972
4.783	13.000	13.000	5.600	3.200	.5264E-05	.5331E-05	.987
4.958	18.000	24.000	4.500	3.600	.4529E-06	.4554E-06	.994

CONTINUED

EO	L1	L2	H	W	RI	RC	R
1.523	8.000	9.000	3.400	2.100	.3019E-04	.2870E-04	1.052
3.993	3.000	7.000	1.200	1.200	.4649E-04	.4218E-04	1.102
5.759	32.000	19.000	5.000	3.800	.2549E-06	.2915E-06	.874
4.622	8.000	14.000	3.300	3.000	.8265E-05	.7919E-05	1.043
4.010	16.000	34.000	6.000	3.500	.3443E-06	.3554E-06	.968
3.044	19.000	22.000	4.300	3.200	.5366E-06	.5294E-06	1.013
5.138	29.000	17.000	5.800	4.300	.5895E-06	.6406E-06	.920
.844	15.000	26.000	4.600	2.400	.9417E-06	.8609E-06	1.093
1.730	9.000	17.000	3.600	3.100	.8470E-05	.7575E-05	1.118
5.508	17.000	21.000	5.800	5.000	.1660E-05	.1746E-05	.951
4.438	15.000	19.000	4.600	4.500	.2289E-05	.2295E-05	.997
5.500	22.000	15.000	3.700	2.200	.2830E-06	.2973E-06	.952
1.736	25.000	24.000	5.900	5.800	.1349E-05	.1334E-05	1.011
2.639	16.000	27.000	6.000	5.200	.1859E-05	.1867E-05	.996
1.732	17.000	18.000	3.400	2.700	.1050E-05	.9233E-06	1.138
4.411	18.000	20.000	5.700	3.500	.9384E-06	.9945E-06	.943

TABLE B-III. SOLUTIONS TO 162 PRELIMINARY CASES

EO	L1	L2	H	W	RI	RC	R
.662	4.	4.	1.	1.	.2119E-03	.2077E-03	1.020
.662	4.	5.	1.	1.	.1169E-03	.1040E-03	1.123
.662	4.	6.	1.	1.	.7188E-04	.5869E-04	1.224
.662	5.	4.	1.	1.	.1204E-03	.1150E-03	1.046
.662	5.	5.	1.	1.	.6641E-04	.5765E-04	1.151
.662	5.	6.	1.	1.	.4093E-04	.3251E-04	1.256
.662	6.	4.	1.	1.	.7587E-04	.7178E-04	1.056
.662	6.	5.	1.	1.	.4184E-04	.3594E-04	1.164
.662	6.	6.	1.	1.	.2573E-04	.2023E-04	1.271
.662	4.	4.	2.	1.	.3574E-03	.4567E-03	.870
.662	4.	5.	2.	1.	.2192E-03	.2422E-03	.905
.662	4.	6.	2.	1.	.1347E-03	.1410E-03	.955
.662	5.	4.	2.	1.	.2258E-03	.2568E-03	.879
.662	5.	5.	2.	1.	.1245E-03	.1368E-03	1.011
.662	5.	6.	2.	1.	.7658E-04	.7986E-04	.912
.662	6.	4.	2.	1.	.1422E-03	.1618E-03	.878
.662	6.	5.	2.	1.	.7846E-04	.8641E-04	.907
.662	6.	6.	2.	1.	.4824E-04	.5044E-04	.956
.662	4.	4.	1.	2.	.8230E-03	.1041E-02	.789
.662	4.	5.	1.	2.	.4538E-03	.5104E-03	.889
.662	4.	6.	1.	2.	.2791E-03	.2832E-03	.985
.662	5.	4.	1.	2.	.4675E-03	.5124E-03	.912
.662	5.	5.	1.	2.	.2578E-03	.2554E-03	1.009
.662	5.	6.	1.	2.	.1585E-03	.1436E-03	1.103
.662	6.	4.	1.	2.	.2945E-03	.2947E-03	.999
.662	6.	5.	1.	2.	.1624E-03	.1488E-03	1.091
.662	6.	6.	1.	2.	.9989E-04	.8436E-04	1.184
.662	24.	24.	6.	6.	.3219E-05	.3172E-05	1.014
.662	24.	30.	6.	6.	.1775E-05	.1717E-05	1.033
.662	24.	36.	6.	6.	.1091E-05	.1039E-05	1.050
.662	30.	24.	6.	6.	.1828E-05	.1773E-05	1.031
.662	30.	30.	6.	6.	.1008E-05	.9608E-06	1.049
.662	30.	36.	6.	6.	.6202E-06	.5803E-06	1.068
.662	36.	24.	6.	6.	.1152E-05	.1103E-05	1.044
.662	36.	30.	6.	6.	.6354E-06	.5972E-06	1.064
.662	36.	36.	6.	6.	.3907E-06	.3613E-06	1.081
.662	24.	24.	12.	6.	.6036E-05	.6628E-05	.910
.662	24.	30.	12.	6.	.3329E-05	.3708E-05	.897
.662	24.	36.	12.	6.	.2047E-05	.2280E-05	.897
.662	30.	24.	12.	6.	.3429E-05	.3806E-05	.900
.662	30.	30.	12.	6.	.1891E-05	.2134E-05	.886
.662	30.	36.	12.	6.	.1163E-05	.1314E-05	.884
.662	36.	24.	12.	6.	.2160E-05	.2406E-05	.897

CONTINUED

E0	L1	L2	H	W	RI	RC	R
.662	36.	30.	12.	6.	.1191E-05	.1350E-05	.882
.662	36.	36.	12.	6.	.7327E-06	.8312E-06	.881
.662	24.	24.	6.	12.	.1249E-04	.1508E-04	.828
.662	24.	30.	6.	12.	.6892E-05	.7911E-05	.871
.662	24.	36.	6.	12.	.4238E-05	.4676E-05	.906
.662	30.	24.	6.	12.	.7100E-05	.7963E-05	.891
.662	30.	30.	6.	12.	.3915E-05	.4239E-05	.923
.662	30.	36.	6.	12.	.2408E-05	.2532E-05	.951
.662	36.	24.	6.	12.	.4473E-05	.4764E-05	.939
.662	36.	30.	6.	12.	.2467E-05	.2561E-05	.963
.662	36.	36.	6.	12.	.1517E-05	.1538E-05	.985
1.250	4.	4.	1.	1.	.1349E-03	.1267E-03	1.064
1.250	4.	5.	1.	1.	.7444E-04	.6455E-04	1.153
1.250	4.	6.	1.	1.	.4577E-04	.3676E-04	1.245
1.250	5.	4.	1.	1.	.7668E-04	.7017E-04	1.092
1.250	5.	5.	1.	1.	.4229E-04	.3582E-04	1.180
1.250	5.	6.	1.	1.	.2600E-04	.2041E-04	1.273
1.250	6.	4.	1.	1.	.4831E-04	.4371E-04	1.105
1.250	6.	5.	1.	1.	.2664E-04	.2232E-04	1.193
1.250	6.	6.	1.	1.	.1638E-04	.1271E-04	1.288
1.250	4.	4.	2.	1.	.2531E-03	.2704E-03	.935
1.250	4.	5.	2.	1.	.1395E-03	.1457E-03	.957
1.250	4.	6.	2.	1.	.8584E-04	.8585E-04	.999
1.250	5.	4.	2.	1.	.1437E-03	.1522E-03	.944
1.250	5.	5.	2.	1.	.7930E-04	.8251E-04	.961
1.250	5.	6.	2.	1.	.4876E-04	.4875E-04	1.000
1.250	6.	4.	2.	1.	.9059E-04	.9588E-04	.944
1.250	6.	5.	2.	1.	.4996E-04	.5212E-04	.958
1.250	6.	6.	2.	1.	.3072E-04	.3083E-04	.996
1.250	4.	4.	1.	2.	.5240E-03	.6615E-03	.792
1.250	4.	5.	1.	2.	.2890E-03	.3250E-03	.889
1.250	4.	6.	1.	2.	.1777E-03	.1808E-03	.982
1.250	5.	4.	1.	2.	.2477E-03	.3221E-03	.924
1.250	5.	5.	1.	2.	.1642E-03	.1614E-03	1.017
1.250	5.	6.	1.	2.	.1009E-03	.9122E-04	1.106
1.250	6.	4.	1.	2.	.1875E-03	.1843E-03	1.017
1.250	6.	5.	1.	2.	.1034E-03	.9381E-04	1.102
1.250	6.	6.	1.	2.	.6361E-04	.5348E-04	1.189
1.250	24.	24.	6.	6.	.2050E-05	.2006E-05	1.021
1.250	24.	30.	6.	6.	.1130E-05	.1094E-05	1.033
1.250	24.	36.	6.	6.	.6952E-06	.6644E-06	1.046
1.250	30.	24.	6.	6.	.1164E-05	.1128E-05	1.032
1.250	30.	30.	6.	6.	.6422E-06	.6168E-06	1.041
1.250	30.	36.	6.	6.	.3949E-06	.3749E-06	1.053
1.250	36.	24.	6.	6.	.7337E-06	.7036E-06	1.042
1.250	36.	30.	6.	6.	.4046E-06	.3844E-06	1.052

CONTINUED

FO	L1	L2	H	W	RI	RC	R
1.250	36.	36.	6.	6.	.2488E-06	.2336E-06	1.065
1.250	24.	24.	12.	6.	.3844E-05	.4095E-05	.938
1.250	24.	30.	12.	6.	.2119E-05	.2311E-05	.917
1.250	24.	36.	12.	6.	.1303E-05	.1428E-05	.912
1.250	30.	24.	12.	6.	.2183E-05	.2371E-05	.920
1.250	30.	30.	12.	6.	.1204E-05	.1340E-05	.898
1.250	30.	36.	12.	6.	.7405E-06	.8303E-06	.891
1.250	36.	24.	12.	6.	.1375E-05	.1504E-05	.914
1.250	36.	30.	12.	6.	.7587E-06	.8519E-06	.890
1.250	36.	36.	12.	6.	.4665E-06	.5276E-06	.884
1.250	24.	24.	6.	12.	.7959E-05	.9603E-05	.828
1.250	24.	30.	6.	12.	.4389E-05	.5047E-05	.869
1.250	24.	36.	6.	12.	.2699E-05	.2988E-05	.903
1.250	30.	24.	6.	12.	.4521E-05	.5083E-05	.889
1.250	30.	30.	6.	12.	.2493E-05	.2716E-05	.918
1.250	30.	36.	6.	12.	.1533E-05	.1626E-05	.942
1.250	36.	24.	6.	12.	.2848E-05	.3048E-05	.934
1.250	36.	30.	6.	12.	.1571E-05	.1690E-05	.929
1.250	36.	36.	6.	12.	.9660E-06	.9927E-06	.973
6.000	4.	4.	1.	1.	.4432E-04	.4033E-04	1.098
6.000	4.	5.	1.	1.	.2444E-04	.2124E-04	1.150
6.000	4.	6.	1.	1.	.1503E-04	.1241E-04	1.210
6.000	5.	4.	1.	1.	.2517E-04	.2252E-04	1.118
6.000	5.	5.	1.	1.	.1388E-04	.1192E-04	1.164
6.000	5.	6.	1.	1.	.8538E-05	.6992E-05	1.221
6.000	6.	4.	1.	1.	.1586E-04	.1416E-04	1.119
6.000	6.	5.	1.	1.	.8748E-05	.7515E-05	1.164
6.000	6.	6.	1.	1.	.5379E-05	.4412E-05	1.219
6.000	4.	4.	2.	1.	.8310E-04	.8251E-04	1.007
6.000	4.	5.	2.	1.	.4583E-04	.4566E-04	1.003
6.000	4.	6.	2.	1.	.2818E-04	.2750E-04	1.024
6.000	5.	4.	2.	1.	.4721E-04	.4658E-04	1.013
6.000	5.	5.	2.	1.	.2603E-04	.2594E-04	1.003
6.000	5.	6.	2.	1.	.1601E-04	.1568E-04	1.021
6.000	6.	4.	2.	1.	.2974E-04	.2959E-04	1.005
6.000	6.	5.	2.	1.	.1640E-04	.1653E-04	.992
6.000	6.	6.	2.	1.	.1008E-04	.1001E-04	1.007
6.000	4.	4.	1.	2.	.1720E-03	.2295E-03	.749
6.000	4.	5.	1.	2.	.9490E-04	.1125E-03	.843
6.000	4.	6.	1.	2.	.5835E-04	.6333E-04	.921
6.000	5.	4.	1.	2.	.9775E-04	.1089E-03	.897
6.000	5.	5.	1.	2.	.5391E-04	.5519E-04	.976
6.000	5.	6.	1.	2.	.3315E-04	.3169E-04	1.046
6.000	6.	4.	1.	2.	.6159E-04	.6229E-04	.988
6.000	6.	5.	1.	2.	.3396E-04	.3218E-04	1.055

CONTINUED

EQ	L1		H	W	RI	RC	R
6.000	6.	6.	1.	2.	.2088E-04	.1873E-04	1.114
6.000	24.	24.	5.	5.	.6730E-06	.7356E-06	.915
6.000	24.	30.	6.	6.	.3712E-06	.4059E-06	.914
6.000	24.	36.	6.	6.	.2282E-06	.2484E-06	.918
6.000	30.	24.	6.	6.	.3823E-06	.4248E-06	.900
6.000	30.	30.	6.	6.	.2108E-06	.2350E-06	.897
6.000	30.	36.	6.	6.	.1296E-06	.1440E-06	.900
6.000	36.	24.	5.	6.	.2409E-06	.2713E-06	.887
6.000	36.	30.	5.	6.	.1328E-06	.1503E-06	.883
6.000	36.	36.	6.	6.	.8170E-07	.9220E-07	.886
6.000	24.	24.	12.	6.	.1262E-05	.1472E-05	.856
6.000	24.	30.	12.	6.	.6960E-06	.8395E-06	.829
6.000	24.	36.	12.	6.	.4280E-06	.5227E-06	.818
6.000	30.	24.	12.	6.	.7170E-06	.8636E-06	.830
6.000	30.	30.	12.	6.	.3954E-06	.4936E-06	.801
6.000	30.	36.	12.	6.	.2431E-06	.3078E-06	.790
6.000	36.	24.	12.	6.	.4517E-06	.5587E-06	.808
6.000	36.	30.	12.	6.	.2491E-06	.3198E-06	.778
6.000	36.	36.	12.	6.	.1531E-06	.1996E-06	.767
6.000	24.	24.	6.	12.	.2613E-05	.3536E-05	.738
6.000	24.	30.	6.	12.	.1441E-05	.1869E-05	.770
6.000	24.	36.	6.	12.	.8862E-06	.1114E-05	.795
6.000	30.	24.	6.	12.	.1484E-05	.1882E-05	.788
6.000	30.	30.	6.	12.	.8187E-06	.1015E-05	.806
6.000	30.	36.	6.	12.	.5034E-06	.6132E-06	.821
6.000	36.	24.	6.	12.	.9353E-06	.1148E-05	.814
6.000	36.	30.	6.	12.	.5158E-06	.6268E-06	.822
6.000	36.	36.	6.	12.	.3172E-06	.3813E-06	.831

DISTRIBUTION LIST

SNDL Code	No. of Activities	Total Copies	
	1	25	Chief, Defense Atomic Support Agency, Washington, D. C.
	1	10	Chief, Bureau of Yards and Docks (Code 42)
23A	1	1	Naval Forces Commanders (Taiwan only)
39B	2	2	Construction Battalions
39D	5	5	Mobile Construction Battalions
39E	3	3	Amphibious Construction Battalions
39F	1	2	Construction Battalion Base Units
A2A	1	1	Chief of Naval Research - Only
A3	2	2	Chief of Naval Operation (OP-07, OP-04)
A5	5	5	Bureaus
B3	2	2	Colleges
E4	1	2	Laboratory ONR (Washington, D. C. only)
E5	1	1	Research Office ONR (Pasadena only)
E16	1	1	Training Device Center
F9	7	7	Station - CNO (Boston; Key West; San Juan; Long Beach; San Diego; Treasure Island; and Rodman, C. Z. only)
F17	6	6	Communication Station (San Juan; San Francisco; Pearl Harbor; Adak, Alaska; and Guam only)
F41	1	1	Security Station
F42	1	1	Radio Station (Osc and Cheltenham only)
F48	1	1	Security Group Activities (Winter Harbor only)
F61	2	2	Naval Support Activities (London and Naples only)
F77	1	1	Submarine Base (Groton, Conn. only)
F81	2	2	Amphibious Bases
H3	7	7	Hospital (Chelsea; St. Albans, Portsmouth, Va.; Beaufort; Great Lakes; San Diego; and Camp Pendleton only)
H6	1	1	Medical Center
J1	2	2	Administration Command and Unit - BuPers (Great Lakes and San Diego only)
J3	1	1	U. S. Fleet Anti-Air Warfare Training Center (Virginia Beach only)
J19	1	1	Receiving Station (Brooklyn only)
J34	1	1	Station - BuPers (Washington, D. C. only)

DISTRIBUTION LIST (Cont'd)

SNDL Code	No. of Activities	Total Copies	
J46	1	1	Personnel Center
J48	1	1	Construction Training Unit
J60	1	1	School Academy
J65	1	1	School CEC Officers
J84	1	1	School Postgraduate
J90	1	1	School Supply Corps
J95	1	1	School War College
J99	1	1	Communication Training Center
L1	11	11	Shipyards
L7	4	4	Laboratory - BuShips (New London; Panama City; Carderock; and Annapolis only)
L26	5	5	Naval Facilities - BuShips (Antigua; Turks Island; Barbados; San Salvador; and Eleuthera only)
L42	2	2	Fleet Activities - BuShips
M27	4	4	Supply Center
M28	6	6	Supply Depot (except Guantanamo Bay; Subic Bay; and Yokosuka)
M61	2	2	Aviation Supply Office
N1	6	18	BuDocks Director, Overseas Division
N2	9	27	Public Works Offices
N5	3	9	Construction Battalion Center
N6	5	5	Construction Officer-in-Charge
N7	1	1	Construction Resident-Officer-in-Charge
N9	6	12	Public Works Center
N14	1	1	Housing Activity
R9	2	2	Recruit Depots
R10	2	2	Supply Installations (Albany and Barstow only)
R20	1	1	Marine Corps Schools (Quantico)
R64	3	3	Marine Corps Base
R66	1	1	Marine Corps Camp Detachment (Tengan only)
W1A1	6	6	Air Station
W1A2	35	35	Air Station
W1B	8	8	Air Station Auxiliary

DISTRIBUTION LIST (Cont'd)

SNDL Code	No. of Activities	Total Copies	
WIC	3	3	Air Facility (Phoenix; Naha; and Naples only)
WIE	6	6	Marine Corps Air Station (except Quantico)
WIH	9	9	Station - BuWeps (except Rota)
	1	1	Deputy Chief of Staff, Research and Development, Headquarters, U. S. Marine Corps, Washington, D. C.
	1	1	President, Marine Corps Equipment Board, Marine Corps School, Quantico, Va.
	1	1	Chief of Staff, U. S. Army, Chief of Research and Development, Department of the Army, Washington, D. C.
	1	1	Office of the Chief of Engineers, Assistant Chief of Engineering for Civil Works, Department of the Army, Washington, D. C.
	1	1	Chief of Engineers, Department of the Army, Washington, D. C., Attn: Engineering Research and Development Division
	1	1	Chief of Engineers, Department of the Army, Washington, D. C., Attn: ENGCW-OE
	1	3	Headquarters, U. S. Air Force, Directorate of Civil Engineering, Washington, D. C., Attn: AFOCE-ES
	1	1	Commanding Officer, U. S. Naval Construction Battalion Center, Port Huachuca, Calif., Attn: Materiel Dept., Code 140
	1	1	Deputy Chief of Staff, Development, Director of Research and Development, Department of the Air Force, Washington, D. C.
	1	1	Director, National Bureau of Standards, Department of Commerce, Connecticut Avenue, Washington, D. C.
	1	2	Office of the Director, U. S. Coast and Geodetic Survey, Washington, D. C.
	1	20	Defense Documentation Center, Building 5, Cameron Station, Alexandria, Va.
	1	2	Director of Defense Research and Engineering, Department of Defense, Washington, D. C.
	1	2	Director, Bureau of Reclamation, Washington, D. C.
	1	1	Facilities Officer, Code 108, Office of Naval Research, Washington, D. C.
	1	1	Federal Aviation Agency, Office of Management Services, Administrative Services Division, Washington, D. C., Attn: Library Branch

DISTRIBUTION LIST (Cont'd)

No. of Activities	Total Copies	
1	2	Commander Naval Beach Group Two, U. S. Naval Amphibious Base, Little Creek, Norfolk, Va.
1	1	Commander, Pacific Missile Range, Technical Documentation Section, P. O. Box 10, Point Mugu, Calif., Attn: Code 4332
1	2	U. S. Army Engineer Research and Development Laboratories, Attn: STINFO Branch, Fort Belvoir, Va.
1	1	Director, U. S. Naval Ordnance Laboratory, White Oak, Silver Springs, Md.
1	1	Office of Naval Research, Branch Office, Navy No. 100, Box 39, FPO, New York
1	1	U. S. Naval Radiological Defense Laboratory, San Francisco
1	1	Officer in Charge, CECOS, Port Hueneme, Calif., Attn: ADCE Course
1	1	U. S. Air Force, Asst. Chief of Staff, Intelligence, Building B, AHS, Washington, D. C., Attn: Mr. Sargent White
1	1	Commander, Air Force Ballistic Missile Division, Air Research and Development Command, P. O. Box 262, Inglewood, Calif.
1	1	Directorate of Research, Air Force Weapons Laboratory, Kirtland Air Force Base, N. M.
1	1	Office of the Chief of Engineers, Department of the Army, T-7, Gravelly Point, Washington, D. C., Attn: ENGNB
1	1	Commanding Officer, Engineer Research and Development Laboratories, Fort Belvoir, Va.
1	1	Office of the Chief of Engineers, Department of the Army, T-7, Gravelly Point, Washington, D. C., Attn: ENG MC-EB
1	1	Director, U. S. Army Engineer Waterways Experiment Station, P. O. Box 631, Vicksburg, Miss., Attn: Mr. G. L. Arbuthnot, Jr.
1	1	U. S. Army Chemical Center, Nuclear Defense Laboratory, Edgewood, Md.
1	1	Director, Ballistic Research Laboratories, Aberdeen, Md.
1	2	Chief, Defense Atomic Support Agency, Washington, D. C.
1	1	Headquarters, Field Command, Defense Atomic Support Agency, Sandia Base, Albuquerque, N. M.
1	1	U. S. Atomic Energy Commission, Technical Information Service, P. O. Box 62, Oak Ridge, Tenn.
1	1	Director, Civil Effects Test Group, Atomic Energy Commission, Washington, D. C.
1	1	Formulation and Analysis Branch, Mathematics and Computation Laboratory, National Resource Evaluation Center, Office of Emergency Planning, Washington, D. C.
1	2	Library of Congress, Washington, D. C.
1	30	Director, Office of Technical Services, Department of Commerce, Washington, D. C.

DISTRIBUTION LIST (Cont'd)

No. of Activities	Total Copies	
1	1	Disaster Recovery Training Officer, Code 450, Construction Battalion Center, Davisville, R. I.
1	1	Mr. William J. Taylor, Terminal Ballistics Laboratory, Aberdeen Proving Ground, Md.
1	1	LCDR Charles W. Gulick, Jr., CEC, USN, Navy No. 926, FPO, San Francisco
1	1	CDR J. C. LeDoux, Office of Civil Defense, Department of Defense, Washington, D. C.
1	1	CAPT W. M. McLellan, CEC, USN, Ret., 468 1st Street, Albany, N. Y.
1	1	LT Edward S. Perry, U. S. Naval Reserve Officers Training Corps Unit, University of Illinois, Urbana, Ill.
1	1	CAPT L. N. Saunders, CEC, USN, Code C10, U. S. Naval Construction Battalion Center, Port Hueneme, Calif.
1	1	CDR E. M. Saunders, CEC, USN, Chief of Naval Materiel, Department of the Navy, Washington, D. C.
1	1	CDR H. E. Stephens, CEC, USN, Bureau of Yards and Docks, Code 41.101, Washington, D. C.
1	1	LCDR R. C. Vance, CEC, USN, Logistics Director, U. S. Naval Civil Engineering Laboratory, Port Hueneme, Calif.
1	1	CDR W. A. Wells, CEC, USN, Disaster Control Division, Bureau of Yards and Docks, Washington, D. C.
1	1	LT COL Charles D. Daniel, USA, Defense Atomic Support Agency, Washington, D. C.
1	1	Mr. L. Neal FitzSimons, Office of Civil Defense, Department of Defense, Washington, D. C.
1	1	Mr. Ben Taylor, Office of Civil Defense, Department of Defense, Washington, D. C.
1	1	Mr. Charles M. Eisenhauer, Radiation Physics Laboratory, National Bureau of Standards, Washington, D. C.
1	1	Mr. O. H. Hill, Building 12, Room 505, Radiation Physics Division, National Bureau of Standards, Washington, D. C.
1	1	CDR J. D. Andrews, CEC, USN, SHAPE Headquarters, APO 55, New York
1	1	CAPT W. J. Christensen, CEC, USN, U. S. Naval Civil Engineering Laboratory, Port Hueneme, Calif.
1	1	CDR J. F. Deben, CEC, USN, U. S. Naval School, CEC Officers, Port Hueneme, Calif.
1	1	LCDR O. L. Drzen, CEC, USN, U. S. Naval School, CEC Officers, Port Hueneme, Calif.
1	1	LCDR N. W. Clements, CEC, USN, Navy Nuclear Power Unit, Fort Belvoir, Va.
1	1	CDR C. Curione, CEC, USN, Resident Officer-In-Charge-Of-Construction, Long Beach Area, P. O. Box XX, Seal Beach, Calif.

DISTRIBUTION LIST (Cont'd)

No. of Activities	Total Copies	
1	1	LT L. K. Donovan, CEC, USN, U. S. Naval Communication Station, Navy No. 85, FPO, San Francisco
1	1	LCDR Walter J. Eager, Jr., CEC, USN, AFRR-NNMC, Bethesda, Md.
1	1	LTJG Clinton W. Kelly, III, CEC, USN, Bureau of Yards and Docks, Program Officer, U. S. Naval Radiological Defense Laboratory, San Francisco
1	1	CDR W. J. Franey, CEC, USN, Bureau of Yards and Docks, Director, Southeast Division, U. S. Naval Base, Charleston, S. C.
1	1	CDR C. F. Krickenberger, CEC, USN, Bureau of Yards and Docks, Code 50.200, Washington, D. C.
1	1	Dr. Lauriston S. Taylor, Chief, Radiation Physics Division, National Bureau of Standards, Washington, D. C.
1	1	Dr. James O. Buchanan, Research Directorate, Office of Civil Defense, Washington, D. C.
1	1	LT S. H. Mathes, CEC, USN, U. S. Naval Construction Battalion Center, Port Hueneme, Calif.
1	1	Mr. Jack C. Greene, Office of Civil Defense, Department of Defense, Washington, D. C.
1	1	Dr. Harold A. Knapp, Fallout Studies Branch, Division of Biology and Medicine, U. S. Atomic Energy Commission, Washington, D. C.
1	1	Dr. Karl Z. Morgan, Director, Health Physics Division, Oak Ridge National Laboratory, Oak Ridge, Tenn.
1	1	Dr. Joseph D. Coker, National Resource Evaluation Center, Executive Office Building, Washington, D. C.
1	1	Dr. Charles F. Ksando, Military Evaluation Division, U. S. Naval Radiological Defense Laboratory, San Francisco
1	1	Mr. John Auxier, Oak Ridge National Laboratory, Oak Ridge, Tenn.
1	1	Dr. William Kreger, Naval Radiological Defense Laboratory, San Francisco
1	1	Dr. Hans Tiller, Nuclear Defense Laboratory, Army Chemical Center, Md.
1	1	Mr. Irving Gaskill, National Resource Evaluation Center, Executive Office Building, Washington, D. C.
1	1	Mr. George Sisson, Office of Civil Defense, Department of Defense, Washington, D. C.
1	1	Mr. James C. Pettee, National Resource Evaluation Center, Executive Office Building, Washington, D. C.
1	1	LTCOL Russell J. Hutchinson, 052921, Office of the Engineer, Camp Walters, Mineral Wells, Tex.
1	1	LCDR I. D. Crowley, CEC, USN, Blast and Shock Division, Defense Atomic Support Agency, Washington, D. C.
1	1	CDR H. L. Murphy, Room 211, Federal Office Building, San Francisco

DISTRIBUTION LIST (Cont'd)

No. of Activities	Total Copies	
1	1	LCDR W. H. Bannister, CEC, USN, Field Command, Defense Atomic Support Agency, Sandia Base, Albuquerque, N. M.
1	1	Major Robert Crawford, USAF, Air Force Weapons Laboratory, Kirtland Air Force Base, Albuquerque, N. M.
1	1	Dr. John Ballech, Director, Operations Analysis, 26th Air Division, SAGE, Hancock Field, Syracuse, N. Y.
1	1	Mr. J. F. Tamonini, A & E Development Division, Office of Civil Defense, Department of Defense, Washington, D. C.
1	1	LCDR C. R. Whipple, CEC, USN, U. S. Naval Ordnance Laboratory, White Oak, Md.
1	1	Dr. W. E. Fisher, Air Force Weapons Laboratory, Kirtland Air Force Base, Albuquerque, N. M.
1	1	Mr. Everitt P. Blizard, Director, Neutron Physics, Oak Ridge National Laboratory, P. O. Box X, Oak Ridge, Tenn.
1	1	LT M. MacDonald, CEC, USN, U. S. Naval School, CEC Officers, Port Hueneme, Calif.
1	1	Library, Engineering Department, University of California, 405 Hilgard Avenue, Los Angeles
1	1	Sandia Corporation, Box 5800, Albuquerque, N. M.
1	1	Rivers and Harbor Library, Princeton University, Princeton, N. J.
1	1	Head, Civil Engineering Department, Carnegie Institute of Technology, Schenley Park, Pittsburgh, Pa.
1	1	Mr. G. H. Albright, Head, Department of Architectural Engineering, 101 Engineering "A" Bldg., The Pennsylvania State University, University Park, Pa.
1	1	Dr. A. F. Dill, Civil Engineering Hall, University of Illinois, Urbana, Ill.
1	1	Dr. N. M. Newmark, Civil Engineering Hall, University of Illinois, Urbana, Ill.
1	1	Professor J. Neils Thompson, Civil Engineering Department, University of Texas, Austin, Tex.
1	1	Mr. Fred Sauer, Physics Department, Stanford Research Institute, Menlo Park, Calif.
1	1	Dr. T. H. Schiffman, Armour Research Foundation of Illinois, Institute of Technology, Technology Center, Chicago, Ill.
1	1	Dr. Robert V. Whitman, Massachusetts Institute of Technology, Cambridge, Mass.
1	1	Dr. Lewis V. Spencer, Ottawa University, Physics Department, Ottawa, Ken.
1	1	Mr. E. E. Shelowitz, Protective Construction, GSA Building, 19th and F Streets, N. W., Washington, D. C.

DISTRIBUTION LIST (Cont'd)

No. of Activities	Total Copies	
1	1	Mr. Werner Weber, Nuclear Engineering Consultant, N. Y. State Civil Defense Commission, P. O. Box 7007, State Office Building, Albany, N. Y.
1	1	Dr. Harold Brode, The Rand Corporation, 1700 Main Street, Santa Monica, Calif.
1	1	Mr. R. D. Cavanaugh, Barry Controls, Inc., 700 Pleasant Street, Watertown, Mass.
1	1	Mr. Kenneth Kaplan, Broadview Research Corporation, 1811 Trousdale Drive, Burlingame, Calif.
1	1	Mr. Thomas Morrison, American Machine and Foundry Company, 7501 North Natchez Avenue, Niles, Ill.
1	1	Mr. Walter Gunther, The Mitre Corporation, P. O. Box 208, Lexington, Mass.
1	1	Mr. W. R. Perret - 5112, Applied Experiments Division, Sandia Corporation, Albuquerque, N. M.
1	1	Mr. Lyndon Welch, Eberle M. Smith Associates, Inc., 153 East Elizabeth Street, Detroit, Mich.
1	1	Professor Herbert M. Bosch, Public Health Engineering, School of Public Health, University of Minnesota, Minneapolis, Minn.
1	1	Dr. Merit P. White, Civil Engineering Department, School of Engineering, University of Massachusetts, Amherst, Mass.
1	1	Dr. Robert J. Hansen, Department of Civil & Sanitary Engineering, Massachusetts Institute of Technology, Cambridge, Mass.
1	1	Mr. Harold Horowitz, Building Research Institute, National Academy of Sciences, 2101 Constitution Avenue, N. W., Washington, D. C.
1	1	Mr. Luke Vortman - 5112, Applied Experiments Division, Sandia Corporation, Albuquerque, N. M.
1	1	Mr. Richard Park, National Academy of Sciences, 2101 Constitution Avenue, N. W., Washington, D. C.
1	1	Mr. Frederick A. Pawley, AIA Research Secretary, American Institute of Architects, 1735 New York Avenue, N. W., Washington, D. C.
1	1	Dr. E. E. Massey, Defense Research Board, Department of National Defense, Ottawa, Canada
1	1	Dr. Robert Repp, The Rand Corporation, 1700 Main Street, Santa Monica, Calif.
1	1	Dr. Stephen B. Withey, Program Director, Survey Research Center, University of Michigan, Ann Arbor, Mich.
1	1	Dr. Eric T. Clarke, Technical Operations, Inc., Burlington, Mass.
1	1	Dr. A. B. Chilton, Civil Engineering Hall, University of Illinois, Urbana, Ill.
1	1	Mrs. Shee Valley, CRTZS, A. F. Cambridge Research Center, L. G. Hanscom Field, Bedford, Mass.
1	1	Dr. J. T. Henley, Department of Civil Engineering, University of Minnesota, Minneapolis, Minn.

DISTRIBUTION LIST (Cont'd)

No. of Activities	Total Copies	
1	1	Chief, Bureau of Ships, Attn: Chief of Research and Development Division, Navy Department, Washington, D. C.
1	1	Officer in Charge, U. S. Naval Biological Laboratory, Naval Supply Center, Oakland, Calif.
1	1	Officer in Charge, U. S. Navy Unit, Rensselaer Polytechnic Institute, Troy, N. Y.
1	1	Chief, Bureau of Medicine and Surgery, Attn: Research Division, Navy Department, Washington, D. C.
1	1	Officer in Charge, U. S. Naval Supply Research and Development Facility Naval Supply Center, Attn: Library, Bayonne, N. J.
1	1	Director, Marine Physical Laboratory, U. S. Navy Electronics Laboratory, San Diego, Calif.
1	1	Chief, Bureau of Naval Weapons, Attn: Research Division, Navy Department, Washington, D. C.
1	1	Commander, Pacific Missile Range, Attn: Technical Director, Point Mugu, Calif.
1	1	Officer in Charge, U. S. Naval Supply Research and Development Facility, Naval Supply Center, Bayonne, N. J.
1	1	Commander, Norfolk Naval Shipyard, Attn: Chemical Laboratory, Portsmouth, Va.
1	1	Commanding Officer, Fleet Training Center, Navy No. 128, FPO, San Francisco, Calif.
1	1	Commander, U. S. Naval Shipyard, Attn: Rubber Laboratory, Mare Island, Vallejo, Calif.
1	1	Commander, U. S. Naval Shipyard, Attn: Material Laboratory, Brooklyn 1, N. Y.
1	1	Office of Naval Research, Branch Office, Navy No. 100, Box 39, FPO, N. Y.
1	1	Commanding Officer, Naval Electronics Laboratory, Attn: Technical Director, San Diego, Calif.
1	1	Commanding Officer, U. S. Naval Unit, U. S. Army Chemical Corps School, Fort McClellan, Ala.
1	1	U. S. Naval Research Laboratory, Chemistry Division, Washington, D. C.
1	1	Commanding Officer, Field Research Laboratory, Bureau of Medicine and Surgery, Camp Lejeune, N. C.
1	1	Deputy Chief of Staff, Research & Development Headquarters, U. S. Marine Corps, Washington, D. C.
1	1	Commanding Officer, Signal Corps Engineering Labs, Fort Monmouth, N. J.
1	1	Directorate of Medical Research, Chemical Warfare Laboratory, Army Chemical Center, Md.
1	1	U. S. Army Cold Regions Research and Engineering Laboratory, Corps of Engineers, P. O. Box 282, Hanover, N. H.

DISTRIBUTION LIST (Cont'd)

No. of Activities	Total Copies	
1	1	Coles Signal Laboratory, Red Bank, N. J.
1	1	Air Force Cambridge Research Center, Hanscom Field, Mass.
1	1	Directorate of Research, Air Force Special Weapons Center, Kirtland Air Force Base, N. M.
1	1	Arctic Aeromedical Laboratory, United States Air Force, APO 731, Seattle, Wash.
1	1	Commanding Officer, Biological Warfare Laboratories, Fort Detrick, Frederick, Md.
1	1	Sandia Corporation, Attn: Classified Document Division, Box 5800, Albuquerque, N. M.
1	1	Chief, Physical Research Branch, Research Division, U. S. Department of Commerce, Bureau of Public Roads, Washington, D. C.
1	1	Department of Zoology, Duke University, Durham, N. Car.
1	1	Director, Engineering Research Institute, University of Michigan, Ann Arbor, Mich.
1	1	Director, Marine Laboratory, University of Miami, Coral Gables, Fla.
1	1	Director, Soil Physics Laboratory, Department of Engineering, Princeton University, Princeton University, Princeton, N. J.
1	1	Director, The Technological Institution, Northwestern University, Evanston, Ill.
1	1	John F. Batter, CONESCO, Inc., 205 Sixth Street, Cambridge, Mass.
1	1	Prof. D. W. Green, 1668 Maple Avenue, Galesburg, Ill.
1	1	John H. Hubbell, National Bureau of Standards, Washington, D. C.
1	1	Robert M. Kinkaid, Edgerton, Germeshausen, and Greer, Inc., P. O. Box 1912, Las Vegas, Nev.
1	1	Dr. R. L. Ashley, Atomics International, P. O. Box 309, Canoga Park, Calif.
1	1	Ballistic Research Laboratories, Director, Aberdeen, Md.
1	1	Civil Effects Test Group, Director, Atomic Energy Commission, Washington, D. C.
1	1	Library, University of Alaska, Fairbanks, Alaska
1	1	Library, Battelle Institute, Columbus, Ohio
1	1	Library, University of Southern California, University Park, Los Angeles, Calif.
1	1	Library, Institute of Technology, University of Minnesota, Minneapolis, Minn.
1	1	Library, California Institute of Technology, Pasadena, Calif.
1	1	Dr. H. E. Stanton, Physics Division, Argonne National Laboratory, Argonne, Ill.
1	1	Dr. C. W. Terrell, Armour Research Foundation, 10 West 35th Street, Chicago, Ill.
1	1	S. K. Penny, Radiation Shielding Information Center, Oak Ridge National Laboratory, P. O. Box X, Oak Ridge, Tenn.

DISTRIBUTION LIST (Cont'd)

No. of Activities	Total Copies	
1	1	Professor J. Silverman, Department of Chemical Engineering, University of Maryland, College Park, Md.
1	1	Dr. F. T. Mevis, Dean, College of Engineering, University of Maryland, College Park, Md.
1	1	Dr. Raymond R. Fox, Associate Professor and Director, Protective Construction Courses, The George Washington University, Washington, D. C.
1	1	Professor M. L. P. Go, Civil Engineering Department, University of Hawaii, Honolulu, Hawaii
1	1	Dr. James P. Remaldi, Department of Civil Engineering, Carnegie Institute of Technology, Pittsburg, Pa.
1	1	Dr. Nicholas Ferrone, Structural Mechanics Branch, Office of Naval Research, Department of the Navy, Washington, D. C.
1	1	Dr. Aleksandar Sedmak Vesić, Associate Professor, Georgia Institute of Technology, Atlanta, Georgia
1	1	Mr. C. C. Mow, The Rand Corporation, 1700 Main Street, Santa Monica, Calif.
1	1	Systems Engineering Group, Deputy for Systems Engineering, Directorate of Technical Publications and Specifications, Wright-Patterson AFB, Ohio
1	1	Dr. William L. White, Stanford Research Institute, Menlo Park, Calif.
1	1	Mr. H. R. Dvorak, Director, Nuclear Research and Development, P. O. Box 748, Fort Worth, Tex.
1	1	Dr. R. C. Doherty, Southwest Research Institute, San Antonio, Tex.

U. S. Naval Civil Engineering Laboratory
Technical Report R-349
AN EMPIRICAL FORMULA FOR CALCULATING
GAMMA-RAY DOSE ATTENUATION IN
CONCRETE DUCTS, by W. C. Ingold and
C. M. Huddleston
72 p. illus 25 Nov 64 UNCLASSIFIED

A survey is presented of the current status of the calculation of gamma-ray dose-rate attenuation in air ducts through concrete. A simple empirical formula is exhibited which shows satisfactory agreement with the results of more complicated computational techniques and with experimental results. This simple formula represents a large saving in computation time — 2 seconds per case compared to 400 seconds by IBM-1620 computer. Its validity is established for a wide range of duct geometries and for gamma-ray energies up to 3 Mev.

1. Shelters — Dose rates
2. Radiation streaming
- I. Ingold, W. C.
- II. Huddleston, C. M.
- III. Y-F008-08-05-201
- IV. DASA-11.026

U. S. Naval Civil Engineering Laboratory
Technical Report R-349
AN EMPIRICAL FORMULA FOR CALCULATING
GAMMA-RAY DOSE ATTENUATION IN
CONCRETE DUCTS, by W. C. Ingold and
C. M. Huddleston
72 p. illus 25 Nov 64 UNCLASSIFIED

A survey is presented of the current status of the calculation of gamma-ray dose-rate attenuation in air ducts through concrete. A simple empirical formula is exhibited which shows satisfactory agreement with the results of more complicated computational techniques and with experimental results. This simple formula represents a large saving in computation time — 2 seconds per case compared to 400 seconds by IBM-1620 computer. Its validity is established for a wide range of duct geometries and for gamma-ray energies up to 3 Mev.

U. S. Naval Civil Engineering Laboratory
Technical Report R-349
AN EMPIRICAL FORMULA FOR CALCULATING
GAMMA-RAY DOSE ATTENUATION IN
CONCRETE DUCTS, by W. C. Ingold and
C. M. Huddleston
72 p. illus 25 Nov 64 UNCLASSIFIED

A survey is presented of the current status of the calculation of gamma-ray dose-rate attenuation in air ducts through concrete. A simple empirical formula is exhibited which shows satisfactory agreement with the results of more complicated computational techniques and with experimental results. This simple formula represents a large saving in computation time — 2 seconds per case compared to 400 seconds by IBM-1620 computer. Its validity is established for a wide range of duct geometries and for gamma-ray energies up to 3 Mev.

1. Shelters — Dose rates
2. Radiation streaming
- I. Ingold, W. C.
- II. Huddleston, C. M.
- III. Y-F008-08-05-201
- IV. DASA-11.026

U. S. Naval Civil Engineering Laboratory
Technical Report R-349
AN EMPIRICAL FORMULA FOR CALCULATING
GAMMA-RAY DOSE ATTENUATION IN
CONCRETE DUCTS, by W. C. Ingold and
C. M. Huddleston
72 p. illus 25 Nov 64 UNCLASSIFIED

A survey is presented of the current status of the calculation of gamma-ray dose-rate attenuation in air ducts through concrete. A simple empirical formula is exhibited which shows satisfactory agreement with the results of more complicated computational techniques and with experimental results. This simple formula represents a large saving in computation time — 2 seconds per case compared to 400 seconds by IBM-1620 computer. Its validity is established for a wide range of duct geometries and for gamma-ray energies up to 3 Mev.

1. Shelters — Dose rates
2. Radiation streaming
- I. Ingold, W. C.
- II. Huddleston, C. M.
- III. Y-F008-08-05-201
- IV. DASA-11.026

Unclassified

Security Classification

DOCUMENT CONTROL DATA - R&D		
<small>(Security classification of title, body of abstract and indexing annotation must be entered when the overall report is classified)</small>		
1. ORIGINATING ACTIVITY (Corporate author) U. S. Naval Civil Engineering Laboratory Port Hueneme, California 93041		2a. REPORT SECURITY CLASSIFICATION Unclassified
		2b. GROUP
3. REPORT TITLE An Empirical Formula for Calculating Gamma-Ray Dose Attenuation in Concrete Ducts		
4. DESCRIPTIVE NOTES (Type of report and inclusive dates) Task phase (10/63 - 9/64)		
5. AUTHOR(S) (Last name, first name, initial) Ingold, W. C. Huddleston, C. M.		
6. REPORT DATE 25 November 1964	7a. TOTAL NO. OF PAGES 72	7b. NO. OF REFS 18
8a. CONTRACT OR GRANT NO. DASA 11.026	8b. ORIGINATOR'S REPORT NUMBER(S) TR-349	
a. PROJECT NO. Y-F008-08-05-201		
c.		
d.	8c. OTHER REPORT NO(S) (Any other numbers that may be assigned this report)	
10. AVAILABILITY/LIMITATION NOTICES Copies available at OTS \$2.00 Qualified requesters may obtain copies of this report from DDC		
11. SUPPLEMENTARY NOTES	12. SPONSORING MILITARY ACTIVITY BuDocks - DASA	
13. ABSTRACT <p>A survey is presented of the current status of the calculation of gamma-ray dose-rate attenuation in air ducts through concrete. A simple empirical formula is exhibited which shows satisfactory agreement with the results of more complicated computational techniques and with experimental results. This simple formula which may be used for hand computation, represents a vast saving in computation time - 2 seconds per case compared to 400 seconds by IBM-1620.</p>		

DD FORM 1473 0101-807-6800

Unclassified

Security Classification

Preceding Page Blank

14. KEY WORDS	LINK A		LINK B		LINK C	
	ROLE	WT	ROLE	WT	ROLE	WT
Empirical equations	8		9			
Formulas	8		9			
Computation	4		4			
Radiation	9		9			
Gamma rays	9		9			
Dosage	9		9			
Ducts	5		5			
Shelters	5		5			
Subsurface structures	5		5			
Surveys (data collection)			8			

INSTRUCTIONS

1. ORIGINATING ACTIVITY: Enter the name and address of the contractor, subcontractor, grantee, Department of Defense activity or other organization (corporate author) issuing the report.

2a. REPORT SECURITY CLASSIFICATION: Enter the overall security classification of the report. Indicate whether "Restricted Data" is included. Marking is to be in accordance with appropriate security regulations.

2b. GROUP: Automatic downgrading is specified in DoD Directive 5200.10 and Armed Forces Industrial Manual. Enter the group number. Also, when applicable, show that optional markings have been used for Group 3 and Group 4 as authorized.

3. REPORT TITLE: Enter the complete report title in all capital letters. Titles in all cases should be unclassified. If a meaningful title cannot be selected without classification, show title classification in all capitals in parenthesis immediately following the title.

4. DESCRIPTIVE NOTES: If appropriate, enter the type of report, e.g., interim, progress, summary, annual, or final. Give the inclusive dates when a specific reporting period is covered.

5. AUTHOR(S): Enter the name(s) of author(s) as shown on or in the report. Enter last name, first name, middle initial. If military, show rank and branch of service. The name of the principal author is an absolute minimum requirement.

6. REPORT DATE: Enter the date of the report as day, month, year, or month, year. If more than one date appears on the report, use date of publication.

7a. TOTAL NUMBER OF PAGES: The total page count should follow normal pagination procedures, i.e., enter the number of pages containing information.

7b. NUMBER OF REFERENCES: Enter the total number of references cited in the report.

8a. CONTRACT OR GRANT NUMBER: If appropriate, enter the applicable number of the contract or grant under which the report was written.

8b, 8c, & 8d. PROJECT NUMBER: Enter the appropriate military department identification, such as project number, subproject number, system numbers, task number, etc.

9a. ORIGINATOR'S REPORT NUMBER(S): Enter the official report number by which the document will be identified and controlled by the originating activity. This number must be unique to this report.

9b. OTHER REPORT NUMBER(S): If the report has been assigned any other report numbers (either by the originator or by the sponsor), also enter this number(s).

10. AVAILABILITY/LIMITATION NOTICES: Enter any limitations on further dissemination of the report, other than those

imposed by security classification, using standard statements such as:

- (1) "Qualified requesters may obtain copies of this report from DDC."
- (2) "Foreign announcement and dissemination of this report by DDC is not authorized."
- (3) "U. S. Government agencies may obtain copies of this report directly from DDC. Other qualified DDC users shall request through _____."
- (4) "U. S. military agencies may obtain copies of this report directly from DDC. Other qualified users shall request through _____."
- (5) "All distribution of this report is controlled. Qualified DDC users shall request through _____."

If the report has been furnished to the Office of Technical Services, Department of Commerce, for sale to the public, indicate this fact and enter the price, if known.

11. SUPPLEMENTARY NOTES: Use for additional explanatory notes.

12. SPONSORING MILITARY ACTIVITY: Enter the name of the departmental project office or laboratory sponsoring (paying for) the research and development. Include address.

13. ABSTRACT: Enter an abstract giving a brief and factual summary of the document indicative of the report, even though it may also appear elsewhere in the body of the technical report. If additional space is required, a continuation sheet shall be attached.

It is highly desirable that the abstract of classified reports be unclassified. Each paragraph of the abstract shall end with an indication of the military security classification of the information in the paragraph, represented as (TS), (S), (C), or (U).

There is no limitation on the length of the abstract. However, the suggested length is from 150 to 225 words.

14. KEY WORDS: Key words are technically meaningful terms or short phrases that characterize a report and may be used as index entries for cataloging the report. Key words must be selected so that no security classification is required. Identifiers, such as equipment model designation, trade name, military project code name, geographic location, may be used as key words but will be followed by an indication of technical context. The assignment of links, roles, and weights is optional.