

AD610286

AMRL-TR-64-116

A SIMPLE CAPACITIVE DISPLACEMENT MEASURING SYSTEM

LOTHAR O. HOEFT, CAPTAIN, USAF

COPY	<u>2</u>	OF	<u>3</u>	<u>elj</u>
HARD COPY				\$. 1.00
MICROFICHE				\$. 0.50

DECEMBER 1964

23 P

DDC
RECEIVED
FEB 1 1965
DDC-IRA C

BIOPHYSICS LABORATORY
AEROSPACE MEDICAL RESEARCH LABORATORIES
AEROSPACE MEDICAL DIVISION
AIR FORCE SYSTEMS COMMAND
WRIGHT-PATTERSON AIR FORCE BASE, OHIO

ARCHIVE COPY

NOTICES

When US Government drawings, specifications, or other data are used for any purpose other than a definitely related Government procurement operation, the Government thereby incurs no responsibility nor any obligation whatsoever, and the fact that the Government may have formulated, furnished, or in any way supplied the said drawings, specifications, or other data, is not to be regarded by implication or otherwise, as in any manner licensing the holder or any other person or corporation, or conveying any rights or permission to manufacture, use, or sell any patented invention that may in any way be related thereto.

Qualified requesters may obtain copies from the Defense Documentation Center (DDC), Cameron Station, Alexandria, Virginia 22314. Orders will be expedited if placed through the librarian or other person designated to request documents from DDC (formerly ASTIA).

Stock quantities available, for sale to the public, from:

Chief, Input Section
Clearinghouse for Federal Scientific and Technical Information, CFSTI
Sills Building
5285 Port Royal Road
Springfield, Virginia 22151

Change of Address

Organizations and individuals receiving reports via the Aerospace Medical Research Laboratories' automatic mailing lists should submit the addressograph plate stamp on the report envelope or refer to the code number when corresponding about change of address or cancellation.

Do not return this copy. Retain or destroy.

The experiments reported herein were conducted according to the "Principles of Laboratory Animal Care" established by the National Society for Medical Research.

A SIMPLE CAPACITIVE DISPLACEMENT MEASURING SYSTEM

LOTHAR O. HOEFT, CAPTAIN, USAF

0

FOREWORD

The capacitive displacement detector described in this report was developed to enable the author to measure the displacement of the guinea pig tympanum as a part of a PhD thesis at the Pennsylvania State University (1961). It has since been used with a condenser microphone to measure the pressure changes produced by the intra-aural acoustic reflex. The latter research was performed in the Neurophysiology Branch, Biodynamics & Bionics Division, Biophysics Laboratory, Aerospace Medical Research Laboratories, Aerospace Medical Division, under Project No. 7232, "Research on the Logical Structure and Function of the Nervous System," and Task No. 723204, "Bionic Neurophysiology." This report covers research performed between March 1962 and July 1964.

The author gratefully acknowledges the comments and encouragement of Drs Eugene Ackerman and Adam Anthony, his advisors at Pennsylvania State University. Acknowledgement is also made to Drs J. R. Mundie and Howard Weiss, of the Aerospace Medical Research Laboratories, for their comments and suggestions made while adapting the detector for use in their research.

This technical report has been reviewed and is approved.

J. W. HEIM, PhD
Technical Director
Biophysics Laboratory

ABSTRACT

This report presents the theory, development and performance of a capacitive displacement detector. The detector senses the displacement changes as changes in the capacitance of a probe located near the body whose displacement is being measured. These capacitance changes are converted into frequency changes by placing the capacitance probe in the tank circuit of an oscillator. The frequency changes are converted into voltage changes by standard FM techniques. The capacitance detector has a sensitivity of 30 volts/φfd. When used with a 0.2 cm diameter probe, the displacement sensitivity was 4.78 volts/cm when the probe to surface distance was 0.1 cm. The noise level was low enough so that the system was able to measure displacements of the order of 10^{-5} cm at frequencies below 1000 cps and displacements of the order of 5×10^{-6} cm at frequencies above 1000 cps. The main advantages of this type of displacement detector over others is the ease of construction and adjustment.

SECTION I

INTRODUCTION

The capacitive displacement detector described in this report was developed to measure the displacements of the tympanic membrane of a guinea pig produced by sound pressure levels of approximately 100 db. These measurements were made as part of an investigation of the transfer function relating tympanum displacement to the sound pressure at the tympanic membrane. The results of this investigation are reported in reference 1. Estimates based on acoustical impedance measurements indicated that the displacement detector should have high enough sensitivity and low enough noise so that displacements of the order of 10^{-5} cm could be measured at frequencies below 1000 cps and displacements of the order of 5×10^{-6} cm could be measured at frequencies above 1000 cps. The size of the external auditory meatus required that the probe be less than 0.23 cm in diameter.

GENERAL CONSIDERATIONS

Before building the displacement detector various alternative displacement measuring methods were considered. The capacitive displacement detector was selected since the tympanum was to be disturbed as little as possible, thus eliminating the use of mirrors or magnets attached to the eardrum, such as were used by Wilska (ref 2) and Kobrak (ref 3). Three types of capacitive displacement detectors were considered: (1) The impedance detector of von Békésy, (2) the capacity bridge of Van Zelst, and (3) an FM detector. These capacitive displacement detectors are described herein.

Von Békésy (ref 4) was the first to report the use of capacitive probe to measure the displacement of the tympanic membrane. He measured the change in the electrical impedance of a capacitive probe by measuring the voltage changes across a resistor in series with the probe, the condenser-resistor combination being fed by a 100 kc constant-voltage generator. A diagrammatic representation of von Békésy's system is shown in figure 1. A major advantage of this system is that the distance between the electrode and the vibrating body can be measured by measuring the average current through the resistor.

Von Békésy reported that with a probe diameter of 1 mm and an interelectrode spacing of 0.5 mm, it was possible to measure displacements of the order of 10^{-6} cm. The noise floor, below which it was impossible to measure, was set by tube noise, resistor noise, and irregularities in the output of the 100-kc oscillator. This detector does not have a tuned circuit at the input; therefore, operation would be quite simple. A disadvantage of this type of capacitive displacement detector is that a double shield is required around the sides of the probe and around the first tube to obtain the high sensitivity. This double shield is complicated to construct. The capacitor displacement described by Hull (ref 5) is similar to that of Békésy, except that Hull used an inductance instead of a resistance, which increased the sensitivity but also made the detector sensitive to frequency modulation.

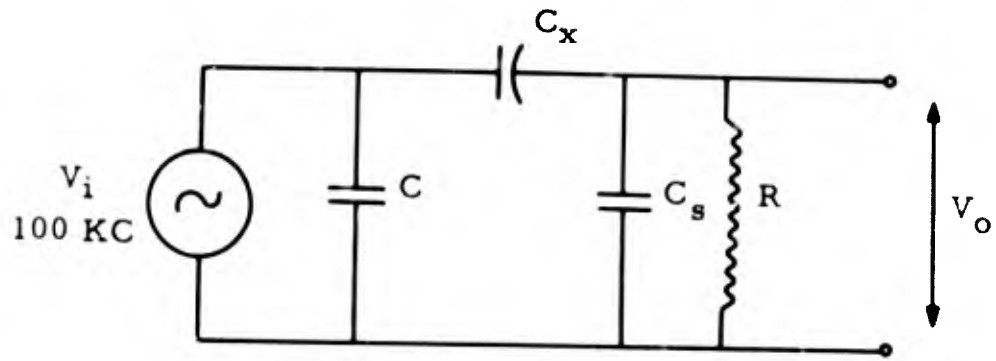

Figure 1: Diagrammatic Representation of Békésy's Displacement Measuring System.

C is the capacity in parallel with the voltage generator V_i , C_x is the active capacity of the probe, C_s is the stray or nonactive capacity of the probe, R is the input resistance of the amplifier used with the probe and V_o is the output voltage of the probe.

Several capacitive displacement detectors have been described which measure capacitive changes by means of a bridge circuit. Such a detector has been reported by von Zelst (ref 6) and later by Fox (ref 7). The capacitive bridge has the advantage that it can be made frequency independent, thus small changes in the carrier frequency would not give rise to changes in the output. The capacitive bridge is also quite sensitive, probably the most sensitive of the capacitive displacement detectors, however, it is generally difficult to tune because several legs of the bridge must be adjusted for balance.

Few frequency modulated capacitive displacement detectors have been described in the literature. These detectors have the varying capacitance in a tank circuit of an oscillator. The capacitive changes are thus transformed into frequency changes. After the FM signal is amplified, the frequency is converted into voltage by a discriminator. This type of detector has the advantage of simple circuitry and, if the sensitivity is not too great, the circuit is easy to tune, having only one adjustment. From the practical standpoint, the transformers and discriminators are readily available if a carrier frequency of 4.5 or 10.7 mc is used.

The sensitivity of the frequency modulated capacitive displacement detector was sufficient for the measurements described earlier. Therefore, this type of detector was chosen over the other two types because of its simpler circuitry and better availability of components.

SECTION II

DERIVATION OF SENSITIVITY

The theoretical sensitivity of the frequency modulated capacitive displacement

detector may be derived by noting that the sensitivity S is equal to

$$S = \frac{dv}{dx} = \left(\frac{\partial v}{\partial c}\right)\left(\frac{\partial c}{\partial x}\right) = \left(\frac{\partial v}{\partial f}\right)\left(\frac{\partial f}{\partial c}\right)\left(\frac{\partial c}{\partial x}\right) \quad (1)$$

where v is the voltage out of the detector, x is the distance between the probe and the body whose displacement is being measured, c is the total capacitance in the tank circuit and f is the resonant frequency of the tank circuit.

The differential $\frac{\partial f}{\partial c}$ may be derived by considering the condition for resonance in a circuit consisting of a capacitance c and an inductance L.

$$f = \frac{(Lc)^{-\frac{1}{2}}}{2\pi} \quad (2)$$

Differentiating both sides with respect to c and substituting equation 2 we get

$$\frac{\partial f}{\partial c} = \frac{-f}{2c} \text{ cps/farad} \quad (3)$$

The term $\frac{\partial c}{\partial x}$ may be derived by first noting that the capacitance of the tank circuit (c) may be divided into two parts, c_x the capacitance which is changing and c_o , the rest of the capacitance is the circuit. Thus,

$$c = c_o + c_x \quad (4)$$

Differentiating equation (4) with respect to x we get:

$$\frac{\partial c}{\partial x} = \frac{\partial c_x}{\partial x} \quad (5)$$

The differential $\frac{\partial v}{\partial f}$ is a function of the detector circuit. The standard FM discriminator characteristic is shown in figure 2. $\frac{\partial v}{\partial f}$ depends on the slope of the discriminator curve and the voltage which is fed to it. For

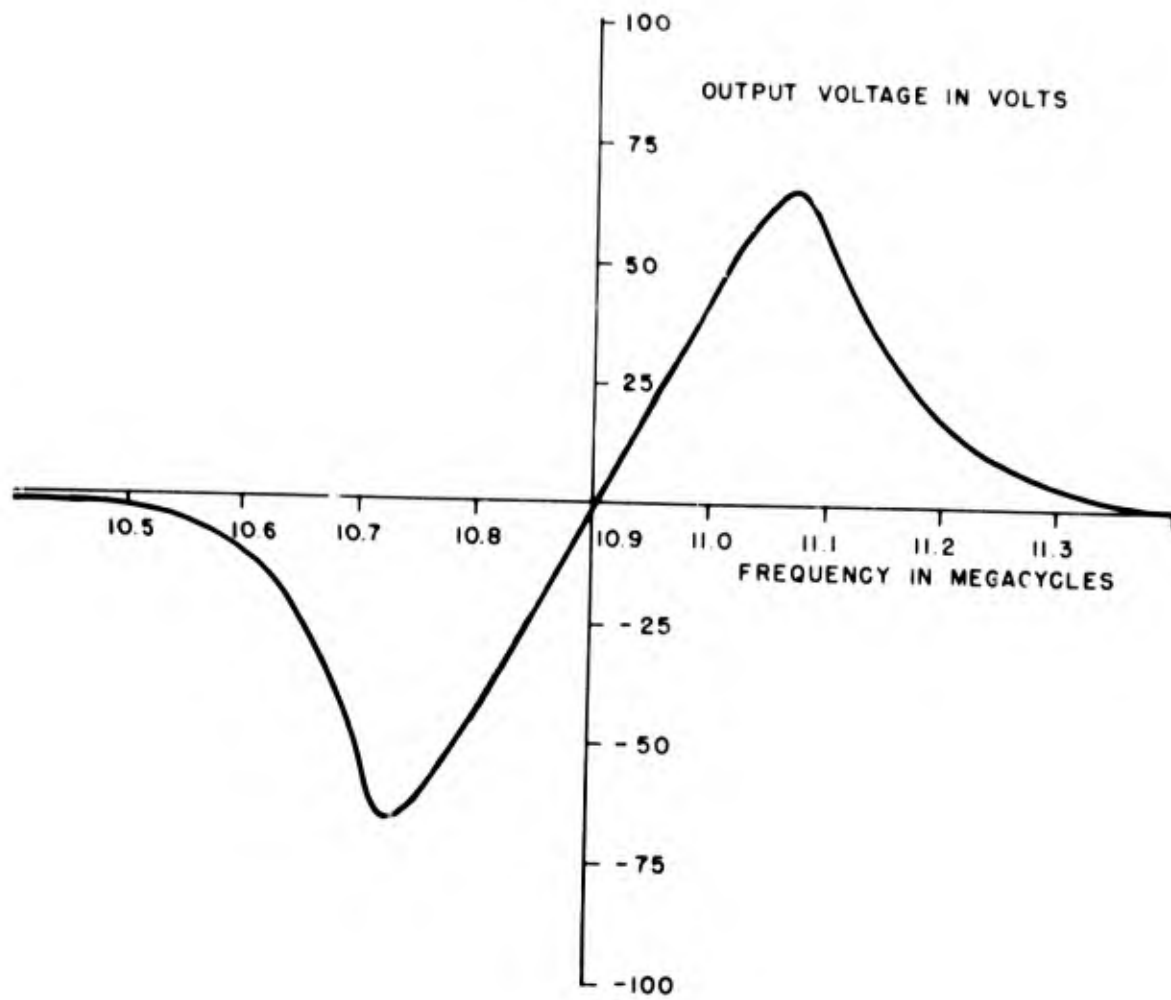

Figure 2: Output Voltage - Frequency Relationship for FM Discriminator

the standard 10.7 mc discriminator fed by a voltage of about 150 volts,

$$\frac{\partial v}{\partial f} = 4.25 \times 10^{-4} \text{ volts/cps} \quad (6)$$

was measured.

Substituting equations (3), (4), (5), and (6) into equation (1) we obtain

$$S = \left[\frac{(4.25 \times 10^{-4})f}{2(c_o + c_x)} \right] \left(\frac{\partial c_x}{\partial x} \right) \quad (7)$$

When the displacement detector is used with a probe, $\frac{\partial c}{\partial x}$ may be approximately calculated by considering the end of the probe to be a parallel plate condenser with a capacitance

$$c_x = \left(\frac{kA}{36\pi x} \right) \times 10^{-11} \text{ farads} \quad (8)$$

Where A is the area of the plate and k is the dielectric constant of the media between the plates,

Then differentiating equation (8) with respect to x, we get

$$\begin{aligned} \frac{\partial c_x}{\partial x} &= -\frac{kA}{36\pi x^2} \times 10^{-11} \\ &= \frac{-c_x}{x} \text{ farads/cm} \end{aligned} \quad (9)$$

Then equation (7) becomes

$$S = \frac{dv}{dx} = \frac{(4.25 \times 10^{-4})f c_x}{2(c_o + c_x)x} \text{ volts/cm} \quad (10)$$

In the case of a probe, c_o is much greater than c_x , therefore, c_x in the denominator can be neglected and we have approximately

$$S \approx \frac{dv}{dx} = \frac{(4.25 \times 10^{-4}) f c_x}{2 c_o x} \quad (11)$$

If equation (8) is substituted into equation (11) and the area A is assumed to be that of a circle of radius r, then

$$S = \frac{(4.25 \times 10^{-4}) f k}{72 c_o} \left(\frac{r}{x}\right)^2 \times 10^{-11} \text{ volts/cm} \quad (12)$$

Equation 10 shows that the sensitivity increases with frequency and active capacitance and decreases with total capacitance and increasing interelectrode distance. Therefore, for best sensitivity, as much of the capacitance as possible should be active, ie, c_x should be large compared to c_o . Unfortunately, this situation is difficult to accomplish in the case of a small probe. However, in the case of a condenser microphone when the active area is large relative to the inactive area, this desirable condition can be approached.

SECTION III

ELECTRONIC CIRCUIT

Figure 3 shows the circuit diagram of the displacement detector in its final form. This circuit was derived from one described by Hannah et al (ref 8) for measuring pressure in a catalytic vessel.

The capacitive probe was made part of the capacity of the tank circuit of a Hartley oscillator which used the triode section of a 6U8A. The pentode section of the 6U8A served as a buffer amplifier between the oscillator and the limiter. The signal was transformer coupled to the 6SQ7 which acted as a limiter, removing amplitude modulation from the signal. Frequency changes were detected by the discriminator and a low output impedance was attained by using a cathode follower output for the a-c signal. This circuit was tuned by adjusting the tank capacitor until the discriminator output was zero. The discriminator output was read on a high impedance d-c vacuum tube voltmeter. The center frequency of the circuit was 10.9 mc and commercial 10.7 mc components were used. Power for the circuit was supplied by a regulated power supply.

Early in the development of the displacement detector, the circuit was excessively microphonic, that is, it was sensitive to vibrations and to airborne sound. Three modifications helped to alleviate this: (1) the use of a triode oscillator instead of the pentode originally used, (2) the use of a tuning condenser of very rigid construction, and (3) the use of a rigid,

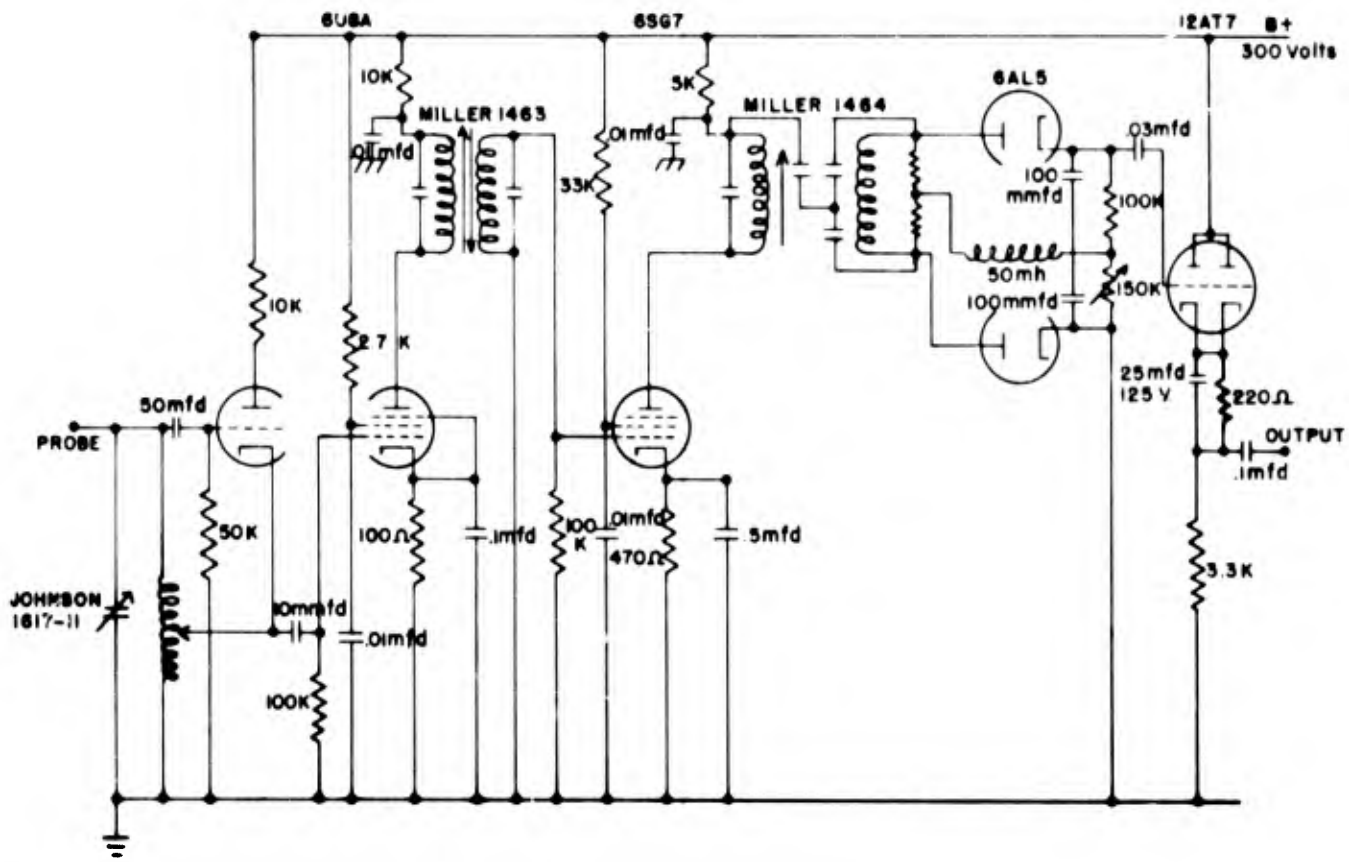

Figure 3: Circuit Diagram of the Displacement Detector

massive construction to eliminate vibrations. The tuning condenser was mounted on a 4 by 4 by 1/2 inch steel plate and the panel of the displacement detector was constructed out of 1/4-inch-steel plate. The entire circuit was mounted in a fiberglass-filled chamber of a concrete box with walls about 3 inches thick. The panel was sealed to the box by a rubber gasket and all holes were sealed. All of these precautions were necessary to reduce the microphonics of the circuit below those of the probe.

If the circuit were used in an application where the capacitive changes were greater, or where the ratio of active capacitance (C_x) to shunt capacitance (C_0) was greater, the microphonic problems would decrease.

THE CAPACITIVE PROBE

During the development of the displacement detector, many different types of capacitive probes were built. Originally, the measurements were to be made with a combination probe tube microphone-displacement probe. In this case the probe tube microphone would measure the sound pressure at its tip and the displacement probe, which would be a tube rather than a flat plate, would measure the displacement of the surface in its vicinity. After testing, this idea was discarded because the probe could not be made small enough and because it was excessively microphonic. Instead, the simpler displacement probe shown in figure 4 was developed, the pressure being measured by a probe tube microphone separate from the displacement probe. This probe was constructed by melting a drop of solder on the end of a length of #20 enameled copper wire. The end of this drop was filed flat and the sides were filed to

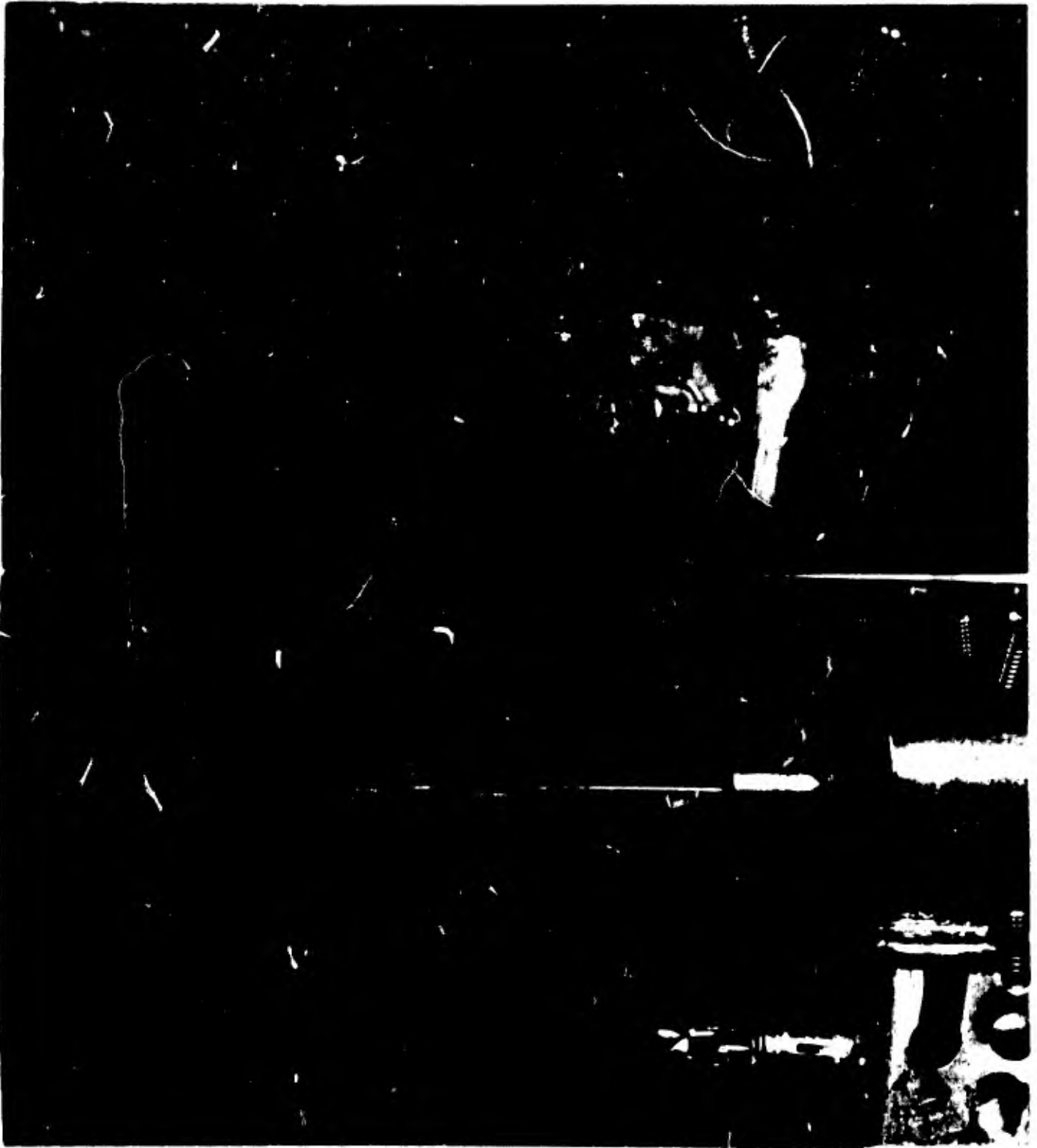

Figure 4: Photograph of Displacement Probe #203B

an approximate conical shape with a tip diameter approximately 0.180 cm. The end was repeatedly dipped in epoxy resin and allowed to set until a suitable thickness was built up on the wire. A piece of shielding from #30 phono wire was placed over the insulated wire and the unit dipped in epoxy resin. The end was filed flat and the sides trimmed until they were of suitable dimensions. A piece of shielded phono wire was soldered to the probe and the shields soldered to a piece of #16 bus bar wire which was used to attach the probe to a micromanipulator. The micromanipulator permitted precise positioning of the probe in the external auditory meatus. The attachment of the probe to the bus bar wire was strengthened with epoxy resin.

SECTION IV

PERFORMANCE

The capacitance detector had a sensitivity of 30 volts/ ρ fd when the total shunt capacitance (C_o) was 70 ρ fd. This compares favorably with the theoretical value of 33 volts/ ρ fd calculated by means of equation 7. A 0.17 X 0.20 cm elliptical probe with a probe/surface distance of 0.1 cm had a sensitivity of 4.74 volts/cm. This compares favorably with the theoretical sensitivity of 9.2 volts/cm calculated using equation(12) considering the errors introduced by the shape of the probe and its beveled surface. In this case, the active capacitance (C_x) was less than 2×10^{-2} ρ fd, thus negligible compared to the shunt capacitance. Figure 5 shows the noise spectrum as measured with a wave analyzer. Below 500 cps, the noise is probably due to 60 cps harmonics. Above 500 cps, the noise is probably due to thermal noise in the tank circuit. Figure 5 also shows the output of the detector when the probe was positioned in the speculum and exposed to a sound pressure level (SPL) of 100 db re 0.0002 microbar.

The operating characteristics and sensitivities of the probes used in this study were measured by means of a displacement calibration system consisting of a brass plate attached to a 5-inch loudspeaker whose displacement was measured with a microscope. This calibration system was used to measure the effect of angle of the probe with respect to the vibrating surface, probe-tip diameter, probe-tip shape, vibrating surface shape and probe surface distance.

The effect of the angle of the probe on the sensitivity is shown in table I. For angles less than 30° , the sensitivity can be assumed to be independent of angle within the error of these experiments.

Several probes were constructed, differing only in tip diameter. The performance and dimensions of these probes are tabulated in table II. A comparison of the sensitivities is not very meaningful, since the probes were not exactly circular and the probe area was hard to calculate. Also, modifications of the circuit changed the sensitivity of the detector between probe calibrations. The data are consistent with the statement that the sensitivity is proportional to the probe-tip area.

Probe 203B seemed to be the best compromise between sensitivity and size, that is, it was large enough to have a respectable sensitivity and small enough to easily fit into a guinea pig ear.

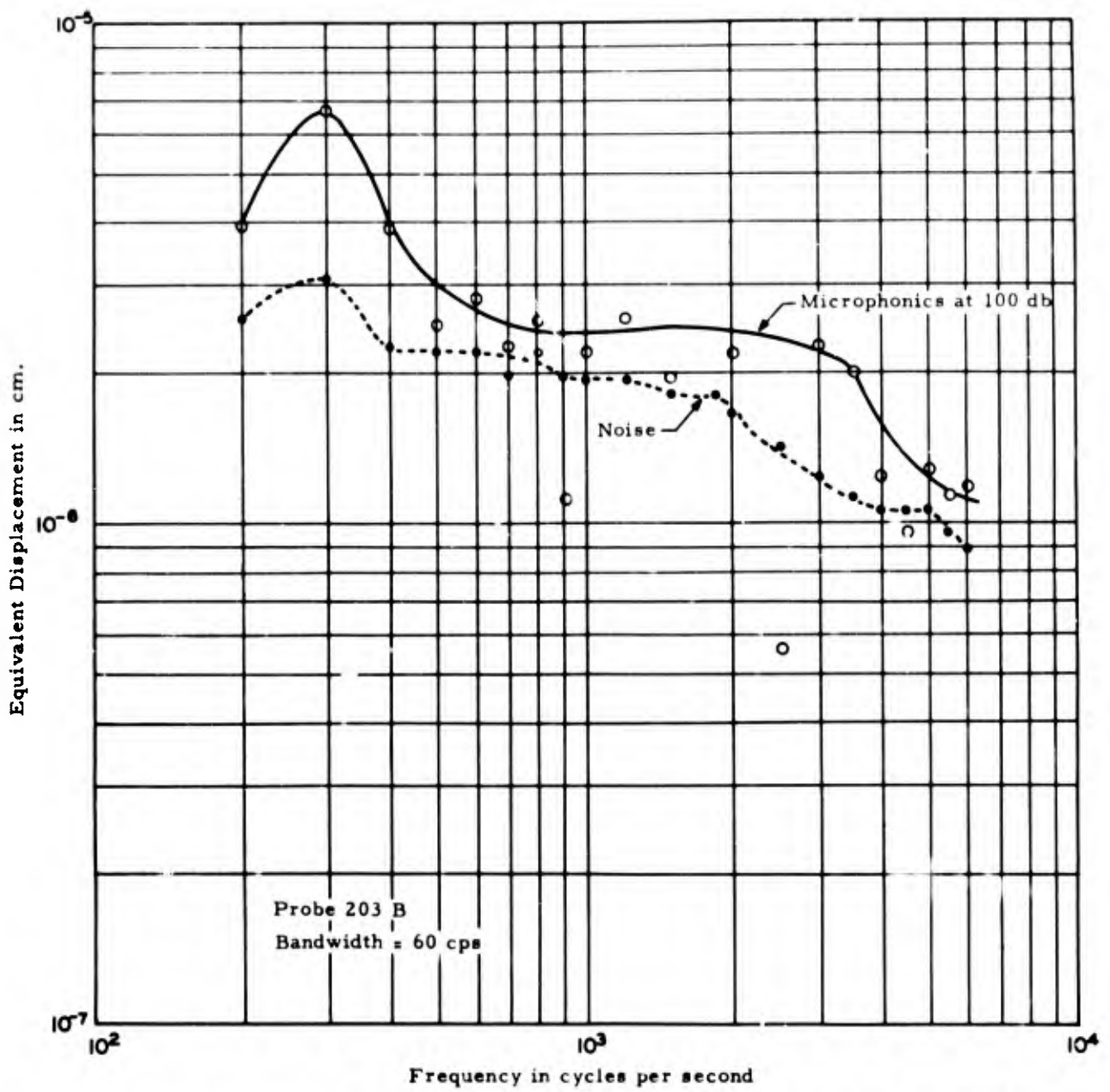

Figure 5: Noise Equivalent Displacement and Microphonic Equivalent Displacement for Probe #203B.

Since the original probe used the end of a tube as one plate of the condenser, a rod of the same diameter was also calibrated. The results, shown in table III, may be interpreted as indicating that the hole in the tube does not alter its sensitivity. The effect of the shield was also investigated. Table III shows that shielding the entire side of the probe reduces the effective area of the probe when compared to a probe with the end left unshielded for about a millimeter of its length. The ends of the probes used in the measurements were left unshielded for about a millimeter of their length to take advantage of this effect.

The effect of distance between the probe and the vibrating surface is shown in figure 6 for several probe-surface conditions. The theoretical $1/x^2$ curve is also plotted on this figure. The curves are normalized by dividing

TABLE I
SENSITIVITY VERSUS PROBE ANGLE

Angle of Probe with Respect to Calibration Surface	Sensitivity Normalized to 0°	
	Flat Plate Calibration Surface	Conical Calibration Surface
0°	1.00	1.00
15°	0.78	0.83
30°	0.96	0.70
45°	1.48	2.01

TABLE II
PERFORMANCE AND DIMENSIONS OF CAPACITANCE PROBES

Probe Number	Probe Diameter (cm)	Sensitivity* (volts/cm)	Remarks
102	0.180	2.31	Tube
102A	0.180	2.79	Beveled
103	0.180	3.6	Tube
203	0.236	2.71	
203A	0.17 x 0.20	4.74	
203B	0.17 x 0.20	4.92	Beveled
205	0.182 x 0.210	1.79	
205A	0.182 x 0.210	2.56	Beveled
206	0.223	2.76	

*Sensitivity measured with a 0.1 cm probe/surface distance

NOTE: The sensitivity measurements cannot be correlated from these measurements since the electronic circuitry was modified between probe calibrations.

TABLE III
PERFORMANCE OF VARIOUS TYPES OF PROBES

Description of Probe	Sensitivity at a probe-surface distance of 0.1 cm.
Tube, 0.180 cm diameter, 0.0071 cm ² area	11.75 volts/cm
Rod, 0.180 cm diameter, 0.0255 cm ² area	23.3 volts/cm
Rod, 0.222 cm diameter, Sides completely shielded	4.73 volts/cm
Rod, 0.222 cm diameter, 0.2 cm of side unshielded	7.94 volts/cm

the sensitivity by the sensitivity at a probe-surface distance of 0.1 cm. The agreement between experiment and theory is not too good. This is interpreted as indicating that the assumption that the probe surface acts like one plate of a parallel plate condenser is a rough approximation. Since the measurement of the probe-membrane distance proved quite difficult, it was desirable to establish the distance where the sensitivity did not change too rapidly with distance. From figure 6 it can be seen that the range 0.05 to 0.1 cm fulfilled this requirement and still maintained an adequate sensitivity.

As mentioned previously, the displacement detector must measure the displacement of the tympanum without appreciably altering its mechanical behavior. Since the capacitive probe does not add mass to the tympanic membrane, mass loading of the tympanum is eliminated. However, the mere presence of the probe in the vicinity of the membrane will load the membrane at high frequencies by changing the radiation field seen by the membrane. This effect may be neglected for the frequencies used in the investigation, ie, below 6 kc.

The oscillator circuit places a 10.7 mc a-c voltage of less than 50 volts between the probe and the tympanum. This voltage produces a force on the tympanum proportional to the square of the voltage. The mass of the tympanum reduces the dynamic portion of this force so that it is insignificant. The static component of this force would displace the tympanum about 4×10^{-8} cm, an insignificant amount.

The frequency response of the displacement detector was not measured because the vibration table was not useful above several hundred cycles per second. However, the bandwidth of the electronic circuit should have the same response

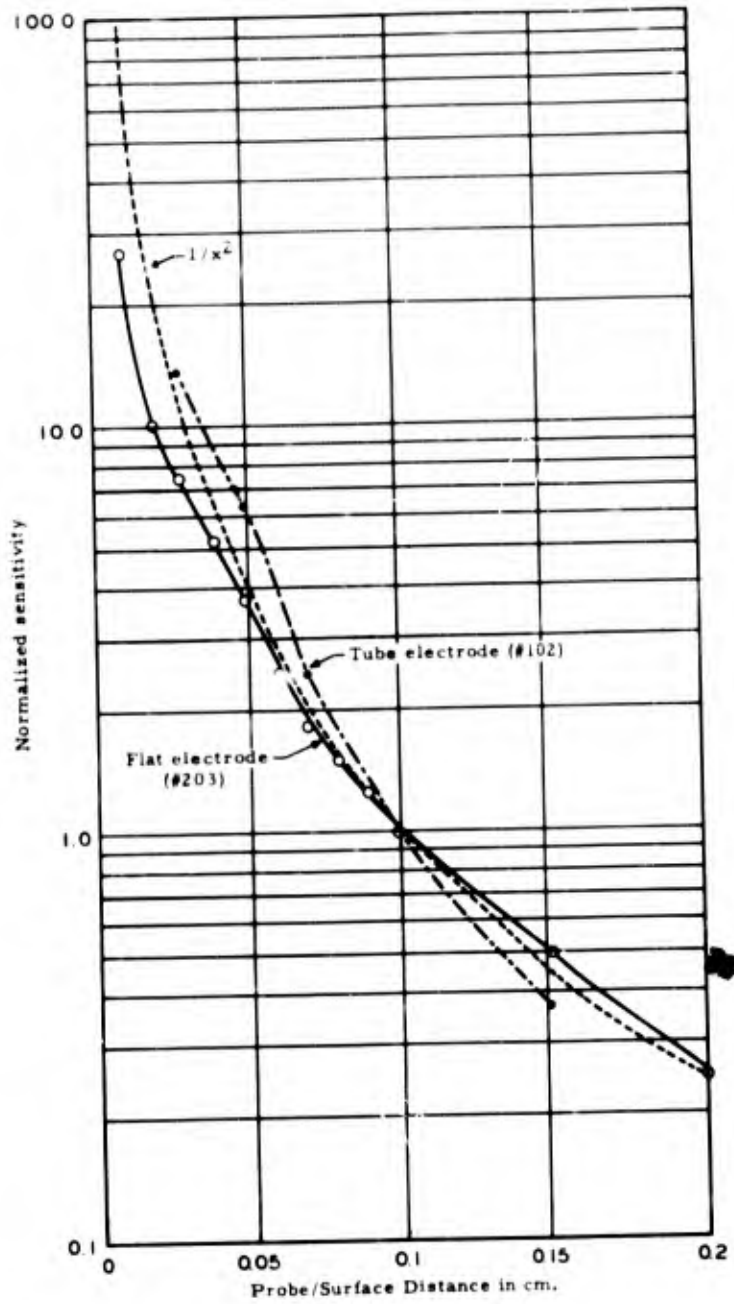

Figure 6: Sensitivity of Probe Versus Probe-Surface Distance

as an FM receiver, namely, 20 kc. The output impedance of the discriminator could also limit high cutoff frequency. This was measured and found to be approximately 45,000 ohms. If the discriminator were loaded by excessive capacitance, the frequency response would be limited.

SECTION V

CONCLUSIONS

The capacitive displacement detector described in this paper proved to be a useful tool for measuring small displacement of the tympanum. Since its original development, it has been used to detect the capacitive changes of a Western Electric 640AA condenser microphone, thus enabling this microphone to be used at very low frequencies. The sensitivity of the microphone using this detector was 15 db more sensitive than when the same microphone was used in a cathode follower preamplifier with 200 volts bias. This sensitivity could be increased by changing the tank inductance so that the dynamic capacitance (C_X) would be of the same order as or greater than the shunt capacitance (C_0).

The main advantages of this detector over others are that it is easy to use and simple construct, especially if commercial 4.5 or 10.7 mc transformers and discriminators are used. The main disadvantages of this detector are that it is not as sensitive and may have a higher noise level. The noise is a function of the oscillator circuit and is not amenable to simple analysis.

The capacitance probes described in this report were suitable for the desired measurement, however, they are not unique and other designs would probably work as well. The compromise necessitated by the requirements for small size, high sensitivity, shielded construction, and freedom from microphonics could be made in other ways than were made here.

REFERENCES

1. Hoefft, Lothar O., Eugene Ackerman and Adam Anthony, "Measurement of the Displacements and Nonlinearities of the Guinea-Pig Tympanum," J. Acoust. Soc. Amer., 36: 1836-1844, October, 1964.
2. Wilska, A., "Eine Methode zur Bestimmung der Hörschwellenamplituden des Trommelfells bei verschiedenen Frequenzen," Skand. Arch. Physiol., 72: 161-165, 1935.
3. Kobrak, H., "Construction Material of the Sound Conduction System of the Human Ear." J. Acoust. Soc. Amer., 20: 125-130, 1948.
4. Békésy, G. von, "Über die Messung der Schwingungsamplitude der Gehörknöchelchen mittels einer kapazitiven Sonde." Akust. Zeits., 6: 1-16, 1941.
5. Hull, G. F., "Resonant Circuit Modulator for Broad Band Acoustic Measurements." Jour. Appl. Phys., 17: 1066-1075, 1946.
6. van Zelst, J. J., "Circuit for Condenser Microphones with Low Noise Level." Philips Tech. Rev., 9: 357-363, 1947-1948.
7. Fox, H. L., "A Wide-Band Carrier System for Condenser Microphones," J. Acoust. Soc. Amer., 33: 853, 1961.
8. Hannah, K. W., M. J. Jancich and N. Hackerman, "An Automatic System for the Study of Catalytic Reactions Involving Gases," Rev. Sci. Inst., 20: 636-639, 1954.

DOCUMENT CONTROL DATA - R&D		
<i>(Security classification of title, body of abstract and indexing annotation must be entered when the overall report is classified)</i>		
1 ORIGINATING ACTIVITY (Corporate author) Aerospace Medical Research Laboratories, Aerospace Medical Division, Air Force Systems Command, Wright-Patterson Air Force Base, Ohio		2a REPORT SECURITY CLASSIFICATION UNCLASSIFIED
		2b GROUP N/A
3 REPORT TITLE A SIMPLE CAPACITIVE DISPLACEMENT MEASURING SYSTEM		
4 DESCRIPTIVE NOTES (Type of report and inclusive dates) Final report, March 1962 - July 1964		
5 AUTHOR(S) (Last name, first name, initial) Hoeft, Lothar O., Captain, USAF		
6 REPORT DATE December 1964	7a TOTAL NO OF PAGES 21	7b NO OF REFS 8
8a CONTRACT OR GRANT NO	9a ORIGINATOR'S REPORT NUMBER(S) AMRL-TR-64-116	
b PROJECT NO 7232		
c Task No. 723204		
d	9b OTHER REPORT NO(S) (Any other numbers that may be assigned this report)	
10 AVAILABILITY/LIMITATION NOTICES Qualified requesters may obtain copies of this report from DDC. Available, for sale to the public, from the Clearinghouse for Federal Scientific and Technical Information, CFSTI (formerly OTS), Sills Bldg, Springfield, Virginia 22151.		
11 SUPPLEMENTARY NOTES	12 SPONSORING MILITARY ACTIVITY Aerospace Medical Research Laboratories, Aerospace Medical Division, Air Force Systems Command, Wright-Patterson AFB, Ohio	
13 ABSTRACT This report presents the theory, development and performance of a capacitive displacement detector. The detector senses the displacement changes as changes in the capacitance of a probe located near the body whose displacement is being measured. These capacitance changes are converted into frequency changes by placing the capacitance probe in the tank circuit of an oscillator. The frequency changes are converted into voltage changes by standard FM techniques. The capacitance detector has a sensitivity of 30 volts/ ρ fd. When used with a 0.2 cm diameter probe, the displacement sensitivity was 4.78 volts/cm when the probe to surface distance was 0.1 cm. The noise level was low enough so that the system was able to measure displacements of the order of 10^{-5} cm at frequencies below 1000 cps and displacements of the order of 5×10^{-6} cm at frequencies above 1000 cps. The main advantages of this type of displacement detector over others is the ease of construction and adjustment.		

14 KEY WORDS Biophysics Guinea pigs Nervous system Physiology Acoustic properties Measuring devices Sensitivity Ear	LINK A		LINK B		LINK C	
	ROLE	WT	ROLE	WT	ROLE	WT

INSTRUCTIONS

1. **ORIGINATING ACTIVITY:** Enter the name and address of the contractor, subcontractor, grantee, Department of Defense activity or other organization (*corporate author*) issuing the report.
- 2a. **REPORT SECURITY CLASSIFICATION:** Enter the overall security classification of the report. Indicate whether "Restricted Data" is included. Marking is to be in accordance with appropriate security regulations.
- 2b. **GROUP:** Automatic downgrading is specified in DoD Directive 5200.10 and Armed Forces Industrial Manual. Enter the group number. Also, when applicable, show that optional markings have been used for Group 3 and Group 4 as authorized.
3. **REPORT TITLE:** Enter the complete report title in all capital letters. Titles in all cases should be unclassified. If a meaningful title cannot be selected without classification, show title classification in all capitals in parenthesis immediately following the title.
4. **DESCRIPTIVE NOTES:** If appropriate, enter the type of report, e.g., interim, progress, summary, annual, or final. Give the inclusive dates when a specific reporting period is covered.
5. **AUTHOR(S):** Enter the name(s) of author(s) as shown on or in the report. Enter last name, first name, middle initial. If military, show rank and branch of service. The name of the principal author is an absolute minimum requirement.
6. **REPORT DATE:** Enter the date of the report as day, month, year; or month, year. If more than one date appears on the report, use date of publication.
- 7a. **TOTAL NUMBER OF PAGES:** The total page count should follow normal pagination procedures, i.e., enter the number of pages containing information.
- 7b. **NUMBER OF REFERENCES:** Enter the total number of references cited in the report.
- 8a. **CONTRACT OR GRANT NUMBER:** If appropriate, enter the applicable number of the contract or grant under which the report was written.
- 8b, 8c, & 8d. **PROJECT NUMBER:** Enter the appropriate military department identification, such as project number, subproject number, system numbers, task number, etc.
- 9a. **ORIGINATOR'S REPORT NUMBER(S):** Enter the official report number by which the document will be identified and controlled by the originating activity. This number must be unique to this report.
- 9b. **OTHER REPORT NUMBER(S):** If the report has been assigned any other report numbers (*either by the originator or by the sponsor*), also enter this number(s).
10. **AVAILABILITY/LIMITATION NOTICES:** Enter any limitations on further dissemination of the report, other than those

imposed by security classification, using standard statements such as:

- (1) "Qualified requesters may obtain copies of this report from DDC."
- (2) "Foreign announcement and dissemination of this report by DDC is not authorized."
- (3) "U. S. Government agencies may obtain copies of this report directly from DDC. Other qualified DDC users shall request through _____."
- (4) "U. S. military agencies may obtain copies of this report directly from DDC. Other qualified users shall request through _____."
- (5) "All distribution of this report is controlled. Qualified DDC users shall request through _____."

If the report has been furnished to the Office of Technical Services, Department of Commerce, for sale to the public, indicate this fact and enter the price, if known.

11. **SUPPLEMENTARY NOTES:** Use for additional explanatory notes.
12. **SPONSORING MILITARY ACTIVITY:** Enter the name of the departmental project office or laboratory sponsoring (*paying for*) the research and development. Include address.
13. **ABSTRACT:** Enter an abstract giving a brief and factual summary of the document indicative of the report, even though it may also appear elsewhere in the body of the technical report. If additional space is required, a continuation sheet shall be attached.

It is highly desirable that the abstract of classified reports be unclassified. Each paragraph of the abstract shall end with an indication of the military security classification of the information in the paragraph, represented as (TS), (S), (C), or (U).

There is no limitation on the length of the abstract. However, the suggested length is from 150 to 225 words.

14. **KEY WORDS:** Key words are technically meaningful terms or short phrases that characterize a report and may be used as index entries for cataloging the report. Key words must be selected so that no security classification is required. Identifiers, such as equipment model designation, trade name, military project code name, geographic location, may be used as key words but will be followed by an indication of technical context. The assignment of links, rules, and weights is optional.