

①

AD610587

AD

USATRECOM TECHNICAL REPORT 64-73 ✓

B

ARMOR PROTECTION FOR PILOT/COPILOT SEAT
WITH CRASH SAFETY FEATURES FOR CH-47A HELICOPTER

BY

DAVID F. THOMPSON

PHILIP HARPER

DECEMBER 1964

COPY	1	OF	1	TR.
HARD COPY				\$. 5.00
MICROFICHE				\$. 1.00

158P

U. S. ARMY TRANSPORTATION RESEARCH COMMAND
FORT EUSTIS, VIRGINIA

CONTRACT DA 44-177-AMC-94(T)
THE BOEING COMPANY
VERTOL DIVISION



DDC
FEB 8 1965
DDC-IRA - C

PROCESSING COPY
ARCHIVE COPY

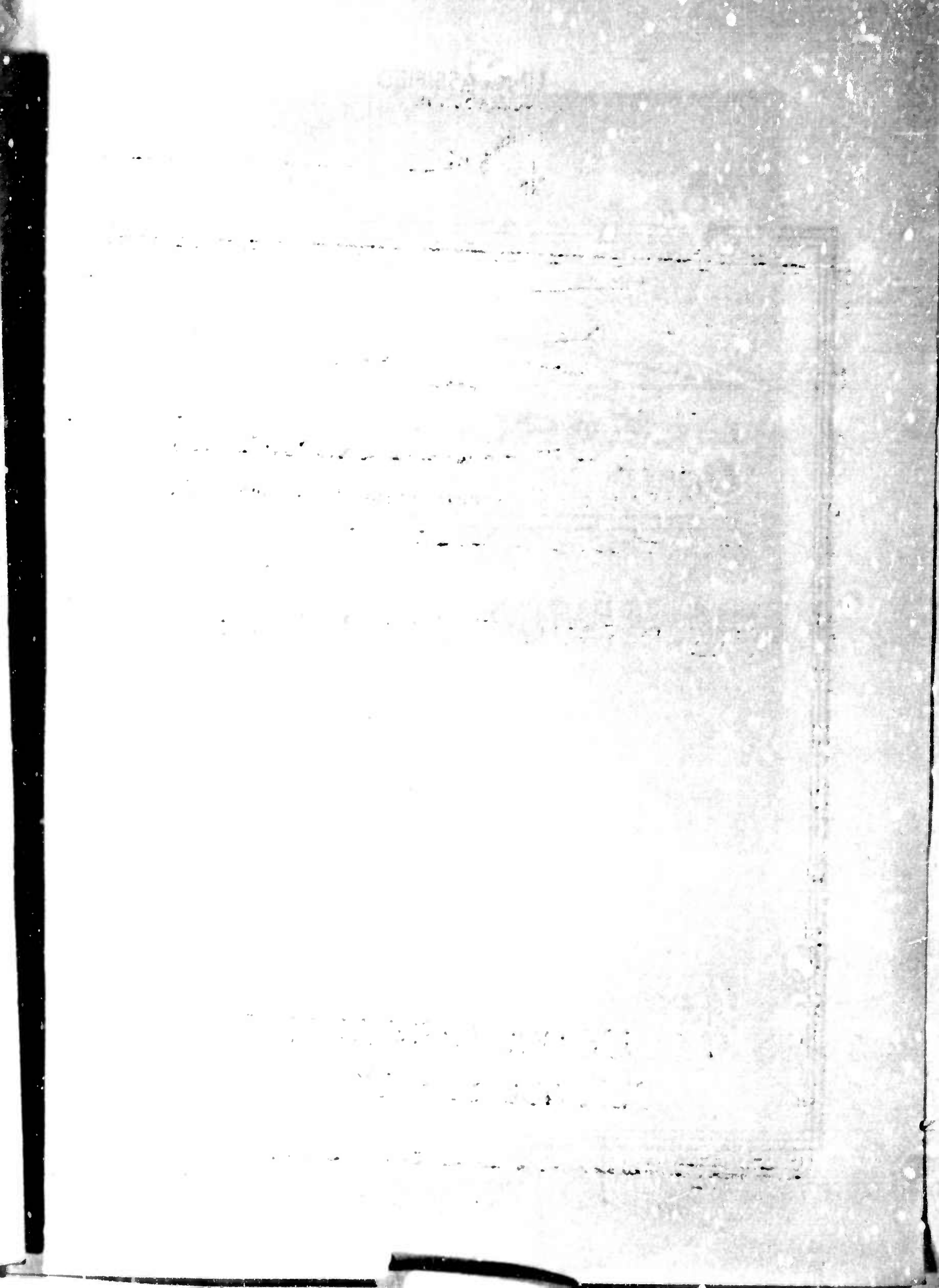

DDC Availability Notice

Qualified requesters may obtain copies of this report from DDC.

This report has been furnished to the Department of Commerce for sale to the general public.

* * *

Reproduction Limitations

Reproduction of this document in whole or in part is prohibited except with permission of the Commanding Officer, USATRECOM. However, DDC is authorized to reproduce the document for United States Government purposes.

* * *

Disclaimer

The findings in this report are not to be construed as an official Department of the Army position, unless so designated by other authorized documents.

When Government drawings, specifications, or other data are used for any purpose other than in connection with a definitely related Government procurement operation, the United States Government thereby incurs no responsibility nor any obligation whatsoever; and the fact that the Government may have formulated, furnished, or in any way supplied the said drawings, specifications, or other data is not to be regarded by implication or otherwise as in any manner licensing the holder or any other person or corporation, or conveying any rights or permission, to manufacture, use, or sell any patented invention that may in any way be related thereto.

* * *

Disposition Instructions

Destroy this report when it is no longer needed. Do not return it to the originator.

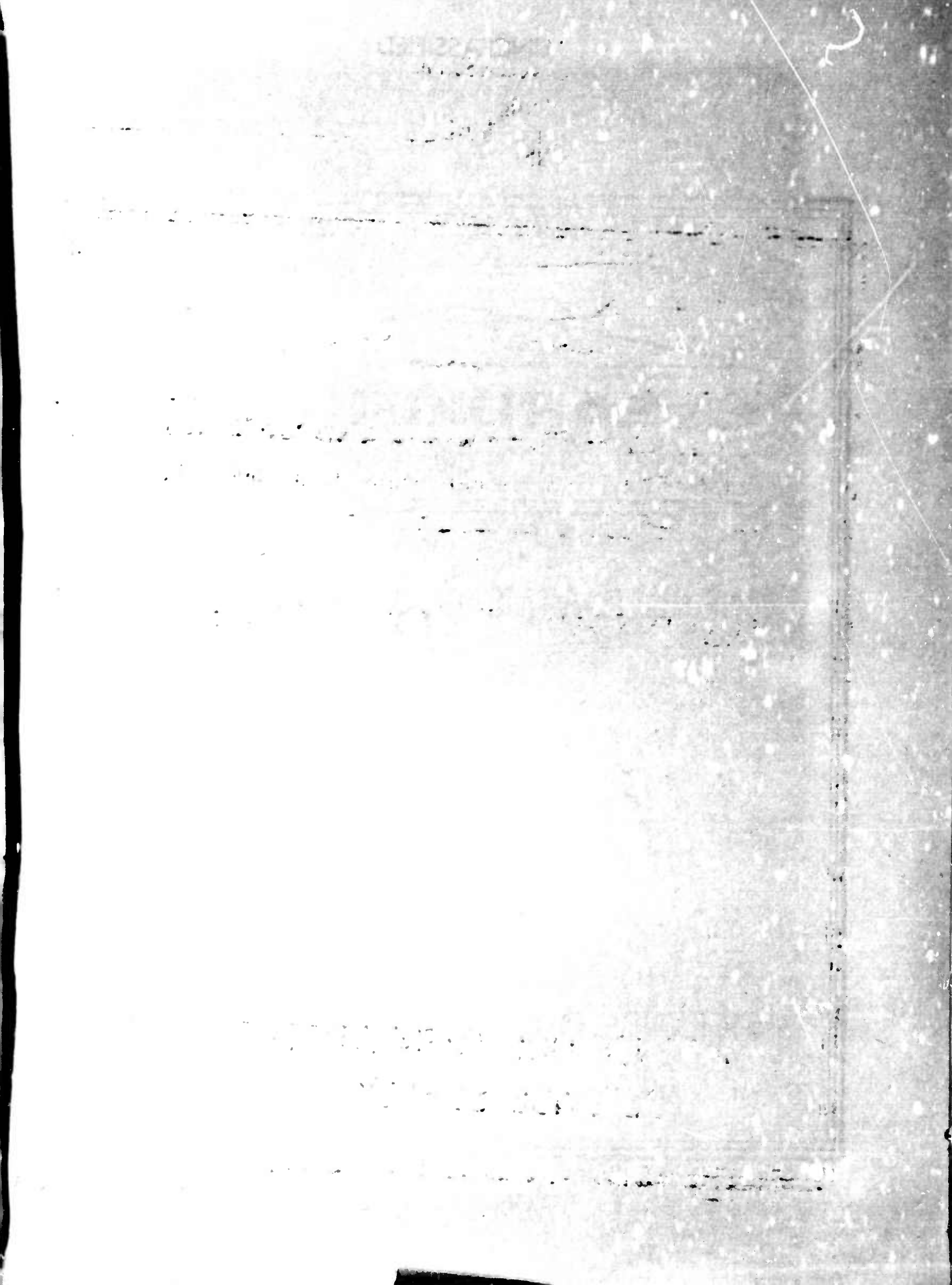

**HEADQUARTERS
U S ARMY TRANSPORTATION RESEARCH COMMAND
PORT EUSTIS, VIRGINIA 23904**

This report has been prepared by the Boeing-Vertol Division under the terms of Contract DA 44-177-AMC-94(T). The technical objectives of this contract called for the design and development of experimental crew seats incorporating composite lightweight armor materials integrated with the seat structure and meeting the design load as herein described.

Conclusions and recommendations contained herein are concurred in by this Command.

Project 1A121401A150
Contract DA 44-177-AMC-94(T)
USATRECOM Technical Report 64-73
December 1964

**ARMOR PROTECTION FOR PILOT/COPILOT
SEAT WITH CRASH SAFETY FEATURES
FOR CH-47A HELICOPTER**

R-361 ✓

Prepared by

THE BOEING COMPANY
Vertol Division
Morton, Pennsylvania

for

U.S. ARMY TRANSPORTATION RESEARCH COMMAND
FORT EUSTIS, VIRGINIA

ABSTRACT

Pilot/copilot protected crash-safety seat was designed and manufactured. Optimum seat and torso protection was attempted. Detail load and stress analysis for accelerations of 20 g vertically and 45 g longitudinally and laterally was made. By using crushable honeycomb type material, an improved torso restraint system and a variable attenuation mechanism were adopted. The feasibility of using protection media as a load bearing structure was demonstrated.

PREFACE

This final technical report is prepared for the U. S. Army Transportation Research Command under Contract DA 44-177-AMC-94(T). It describes the effort of The Boeing Company, Vertol Division in the design and subcontract manufacture of a pilot and copilot armored seat with crash safety features for the CH-47A helicopter.

R. Fama, Project Engineer, was designated as authorized representative of the Contracting Officer, R. P. McKinnon, for the U. S. Army Transportation Research Command.

For the Vertol Division, the investigation and design were conducted by D. F. Thompson, Project Manager, assisted by P. Harper, Design Engineer, under the supervision of L. Kingston, Chief Development Engineer, and R. Wesson, Supervisory Engineer.

Ballistic test samples were evaluated at the Ballistics Research Laboratories, Aberdeen Proving Ground by R. Bernier and D. Mower.

CONTENTS

	<u>Page</u>
ABSTRACT	iii
PREFACE	v
LIST OF ILLUSTRATIONS	ix
SUMMARY	1
CONCLUSIONS	3
RECOMMENDATIONS	4
INTRODUCTION	5
DESIGN LAYOUT STUDY	5
DETAIL DESIGN	11
CRASHWORTHINESS CRITERIA	38
FIELD REPLACEMENT OF ARMOR PANELS	42
REFERENCES	43
DISTRIBUTION	45
APPENDIX I - Installation Changes	47
APPENDIX II - Estimated Weight Breakdown	50
APPENDIX III - Approved Engineering Drawings	51
APPENDIX IV - Loads and Stress Report	52

ILLUSTRATIONS

<u>Figure</u>		<u>Page</u>
1	Armored Pilot Seat - Hardware	x
2	Inboard Profile	7
3	Diagram of Secondary Armor Placement	9
4	Armored Seat Bucket	
	a. Curved Tiles	13
	b. Flat Tiles	15
5	Initial Seat Mock-up in CH-47A Helicopter . .	18
6	Seat Mock-up	
	a. Front View	19
	b. Back View	20
	c. Plan View	21
	d. Side View	22
7	Tube and Die Floor Mounting Seat Support . . .	25
8	Tube and Die Hanging Seat Support.	27
9	"A" Frame Seat Support	29
10	Trussgrid Honeycomb Seat Base Mock-Up	
	a. Forward Side	32
	b. Rear Side	33
11	Load Limiting Behavior	35
12	Load - Stroke Curve	37
13	Side Crash Diagram	39

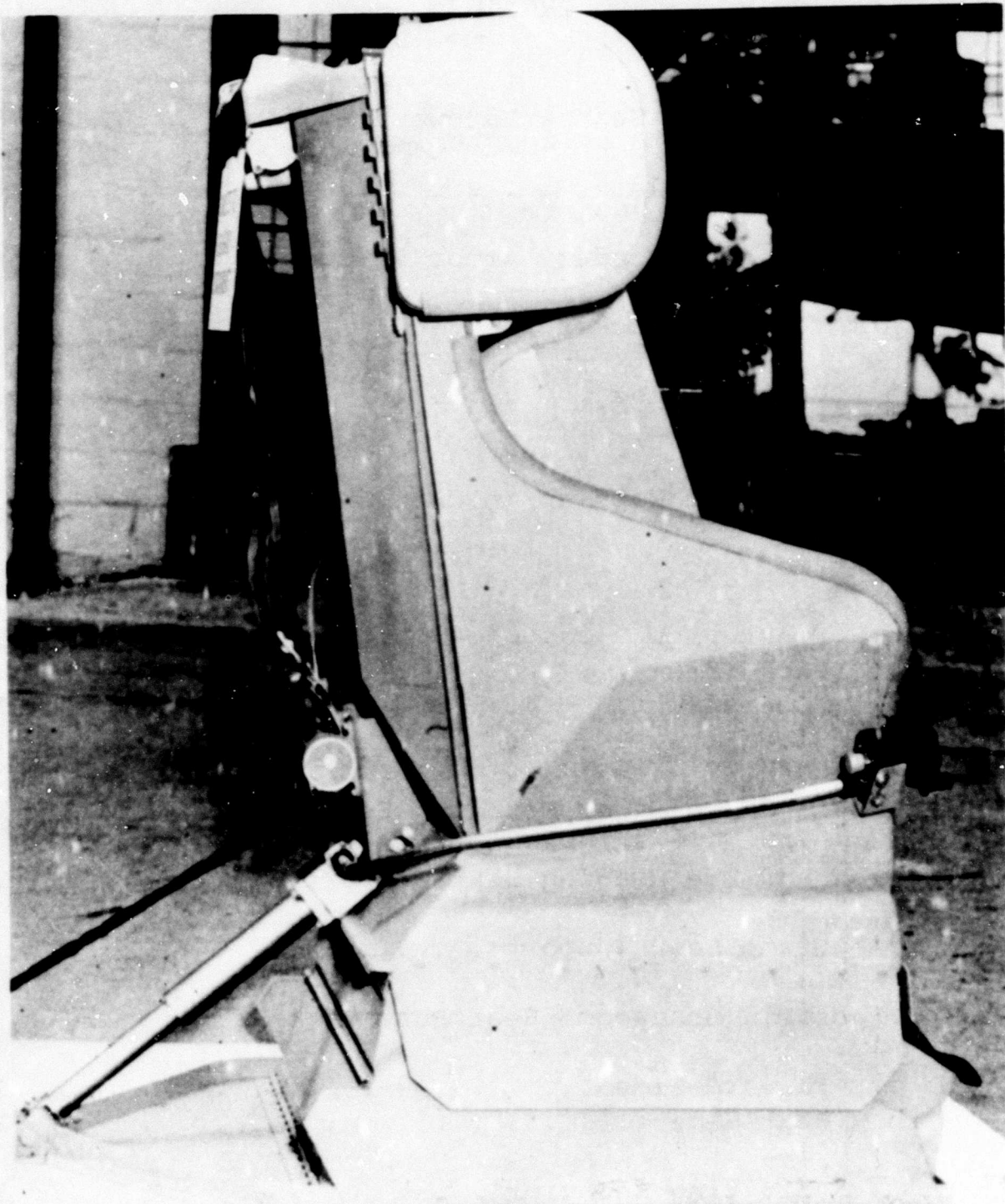

FIGURE 1 ARMORED PILOT SEAT - HARDWARE

SUMMARY

An armored crash pilot/copilot seat was designed and manufactured for the CH-47A helicopter.

The milestones of the program were as follows:

1. GOALS:

- a. The optimum torso armor protection and seat comfort.
 - b. The optimum restraint and attenuation throughout a survivable crash impact up to the human tolerance limit.
2. A design study was performed to achieve an optimum seat configuration. Several basic approaches were investigated and rejected.
 3. The chosen design embodied a wraparound seat bucket and torso protector mounted upon a crushable seat base.
 4. A detail load and stress analysis was performed.
 5. Mock-up seat configurations were constructed.
 6. A mock-up evaluation was performed by ten Vertol test pilots with the seat mounted in a CH-47A helicopter.
 7. Mock-up reviews were conducted at Goodyear Aerospace and at USATRECOM. Inputs from these agencies were incorporated as design changes.
 8. A ballistic armor/seat structure panel evaluation was conducted at the Ballistics Research Laboratories, Aberdeen Proving Ground.
 9. An improved restraint system was developed which uses the armored torso protector as a restraint element. Also, it provides full restraint if the torso protector is not used.

10. Combined seat adjustment and load limit behavior to accommodate the 5th percentile through the 95th percentile man was conceptually achieved in the design.
11. Detail manufacturing drawings were prepared.
12. One aircraft set of seats were manufactured and delivered to USATRECOM.

CONCLUSIONS

1. Armor is most effective when placed as close as possible to the man.
2. Some hampering of the seat occupant is unavoidable if effective ballistic torso protection is to be provided. However, adequate pilot freedom of action is obtained in this seat.
3. Dual use of the armor material as a load bearing structure appears feasible and is employed in this seat design.
4. Provision of high crash-load seat/man retention strength (45 g) is feasible with a moderate weight penalty. Some cockpit structure modification is required for this seat.
5. The articulated crushable toggle block seat chassis can provide seat adjustment and energy-absorbing stroke from any initial adjustment height.

RECOMMENDATIONS

1. Detail design for structural modifications should be made either as permanent structure or as kits to enable the seat to be fitted into the CH-47A cockpit.
(Ref. Appendix B)
2. An immediate test and modification program should be started for development of the crushable seat chassis. This will permit refinement of the assumptions used to predict the energy-absorbing behavior of the design. A series of seat chassis should be fabricated and tested with a "boiler plate" simulated armor seat bucket. These seat chassis should be dynamically tested by AvSER, Phoenix, or Aerospace Aero Equipment Laboratory, Naval Air Material Center (ACEL-NAMC), Philadelphia, with Vertol Division liaison.
3. A test program should be initiated to determine whether a ventilated cushion will be necessary for the torso area when this system is used in elevated ambient temperatures.
4. The advantages of speeding up the seat adjustment by motorizing the seat adjustment screw jack should be investigated.

INTRODUCTION

Operation of Army aircraft in forward areas of a combat environment has proven their need for protection from enemy small-arms fire. To improve the survivability of the crew under hazardous combat conditions, an armored crash-protective pilot seat was designed and fabricated. This was accomplished by Vertol Division of The Boeing Company under USATRECOM Contract DA 44-177-AMC-94(T).

This report describes the approach to the study, design and layout problems involved in using Goodyear Corporation hard-face ceramic armor in a pilot/copilot seat with crash-safety features, shown in Figure 2.

DESIGN LAYOUT STUDY

METHOD OF APPROACH

This armored pilot seat development is an effort to integrate the latest development in armored protection with recent developments in seat design for crash protection of the occupants.

ARMOR PLACEMENT

The primary aim of the placement of armor on the pilot seat is to protect the pilot/copilot. This protection is achieved by providing:

1. A seat bucket composed of four shaped armored panels which attach by screws to a light aluminum-alloy frame. The armor panels serve a dual purpose of carrying seat structural loads. This permits replacement of damaged panels in the field.
2. An armored torso protector which is keyed into the forward edge of the seat bucket. The torso protector is height-adjustable for pilots of various sizes. It is designed to give frontal protection and wraps

around the sides of the torso. Also, it is overlapped by the seat sides and back.

3. Adjustable side panels which are mounted to the upper edges of the seat back for shoulder protection.
4. Optional secondary armor placement to protect arms and legs, as shown in Figure 3.

CRASH-SAFETY FEATURES

The seat is designed structurally to provide a high degree of crash impact protection for the pilot. Design crash load factors, with deformations permitted, are 45 g longitudinally and laterally for a .1-second pulse and 25 g for a .2-second pulse. A special inertia reel and strap carry crash loads from the seat top into the cabin bulkhead, and a high-strength adjustment screw-jack provides retention to the bulkhead/floor intersection.

Vertical crash loads are attenuated by a crushable seat chassis containing structural elements of Trussgrid type aluminum-alloy honeycomb. These structural elements act as seat adjustment links. A minimum of 5½ and a maximum of 9½ inches of vertical crushing is available at a nominal acceleration level of 20 g.

Torso restraint loads from the shoulder harness are fed into the torso protector. This gives area support to the body during forward decelerations. During normal flight the pilot may lean forward because the self-locking inertia reel on the shoulder harness allows forward motion unless 3 g is exceeded. The conventional seat belt and shoulder harness system may be used normally when the torso protector is not used. The seat belt is worn inside the torso protector and directly against the thighs. A thin comfort pad (1 inch thick) mounts in the seat bucket. This thin pad prevents "submarining" under the seat belt. A thick seat pad would usually re-

BLANK PAGE

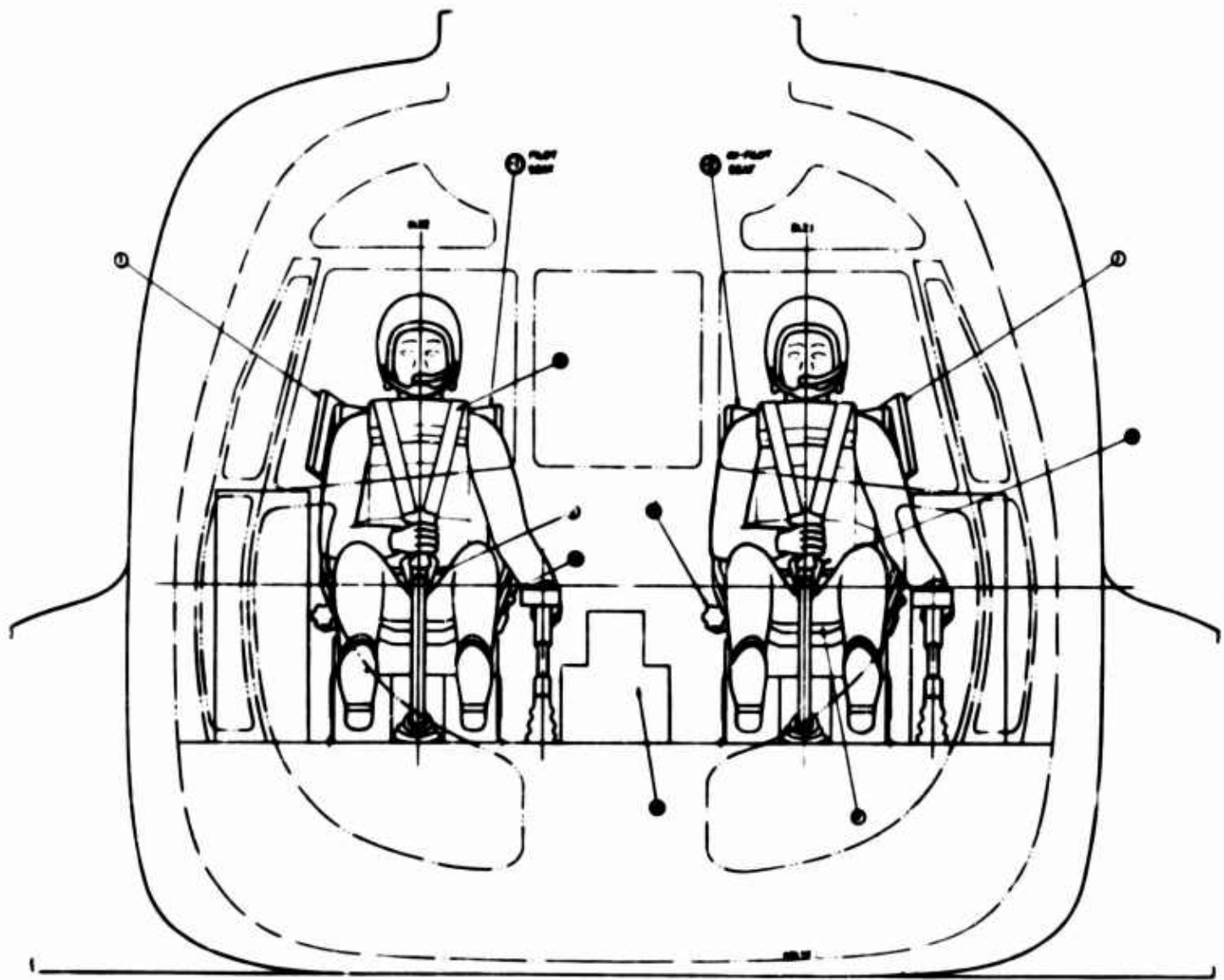

24



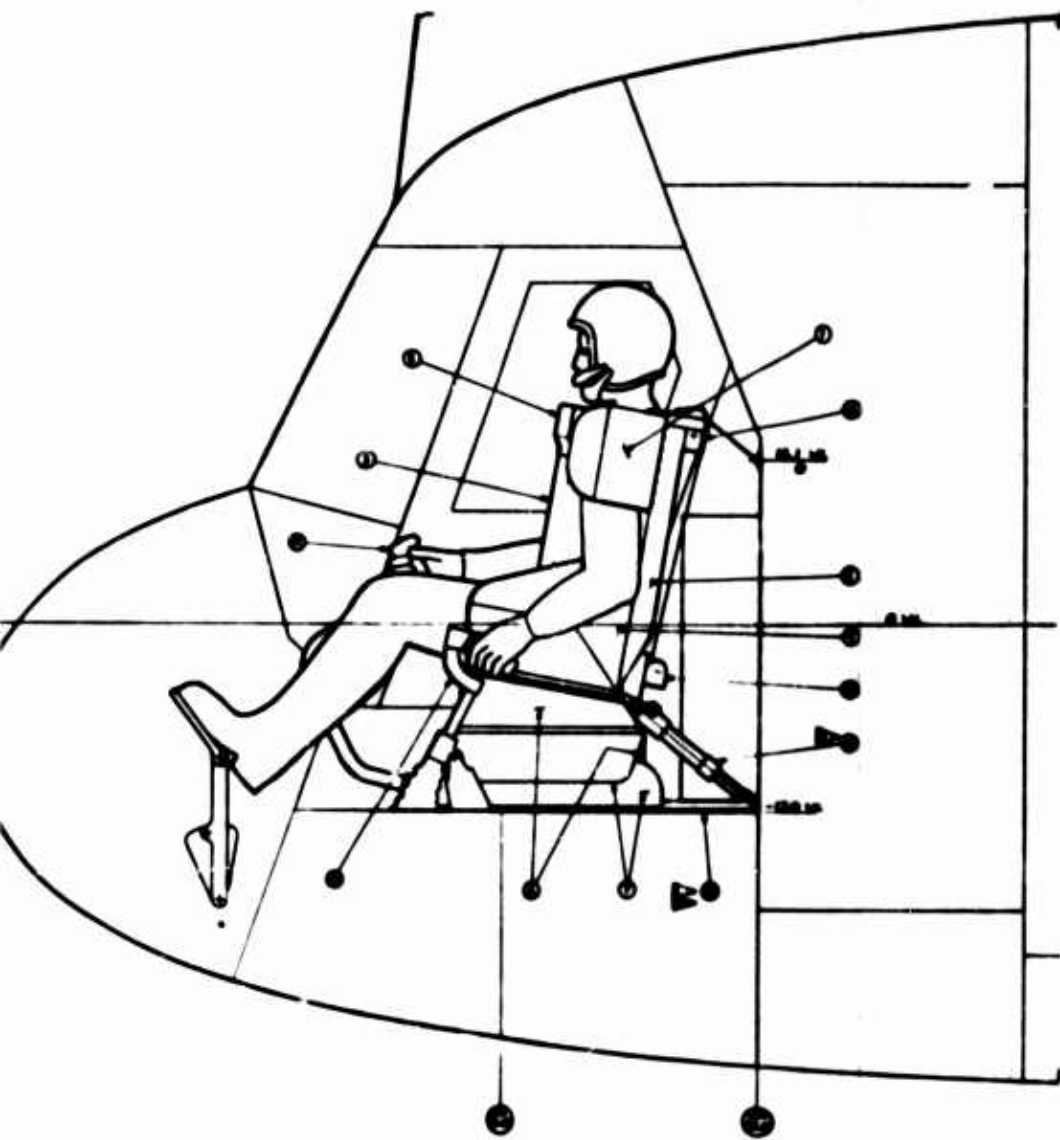

- IDENTIFICATION CODE**
- ① ADJUSTABLE SHOULDER REST, ATTACHED TO THE SEAT
 - ② ADJUSTABLE SEAT BACKREST
 - ③ ADJUSTABLE SEAT RESTRICTION
 - ④ ADJUSTABLE SEAT RESTRICTION UPPER RAIL
 - ⑤ ADJUSTABLE SEAT RESTRICTION LOWER RAIL
 - ⑥ ADJUSTABLE SEAT RESTRICTION LOWER RAIL
 - ⑦ ADJUSTABLE SEAT RESTRICTION LOWER RAIL
 - ⑧ ADJUSTABLE SEAT RESTRICTION LOWER RAIL
 - ⑨ ADJUSTABLE SEAT RESTRICTION LOWER RAIL
 - ⑩ ADJUSTABLE SEAT RESTRICTION LOWER RAIL
 - ⑪ ADJUSTABLE SEAT RESTRICTION LOWER RAIL
 - ⑫ ADJUSTABLE SEAT RESTRICTION LOWER RAIL
 - ⑬ ADJUSTABLE SEAT RESTRICTION LOWER RAIL
 - ⑭ ADJUSTABLE SEAT RESTRICTION LOWER RAIL
 - ⑮ ADJUSTABLE SEAT RESTRICTION LOWER RAIL
 - ⑯ ADJUSTABLE SEAT RESTRICTION LOWER RAIL
 - ⑰ ADJUSTABLE SEAT RESTRICTION LOWER RAIL
 - ⑱ ADJUSTABLE SEAT RESTRICTION LOWER RAIL

- NOTES -**
- ▷ THESE SEATS ARE DESIGNED TO BE PERMANENTLY ATTACHED TO THE AIRCRAFT FLOOR AND CONTROL AT AN ANGLE OF 20° TO SEATS.
 - ▷ POSITIONING OF THESE SEATS IN THE COCKPIT REQUIRES A MODIFICATION TO THE AIRCRAFT FLOOR STRUCTURE AND POSITIONING OF THE SEAT RESTRICTION ON THE BACK OF THE SEAT AT (A) THROUGH (B) OF THE FLOOR/SHOULDER RESTRICTION ATTACHED TO THE SEAT.
 - ▷ THE SEAT RESTRICTION IS BASED ON THE 20° ANGLE OF THE SEAT THROUGH THE SEAT RESTRICTION AT 20° TO SEATS.
 - ▷ THE SEAT RESTRICTION POSITION SHALL APPROXIMATELY THAT SHOWN IN A SEAT ON THE AIRCRAFT FLOOR IS DESIGNED FOR ALTERNATE ATTACHMENT TO THE LAP SEAT IN THE NORMAL USE OF THE SEAT IS USED WITHOUT THE SEAT RESTRICTION.

FIGURE 2 INBOARD PROFILE

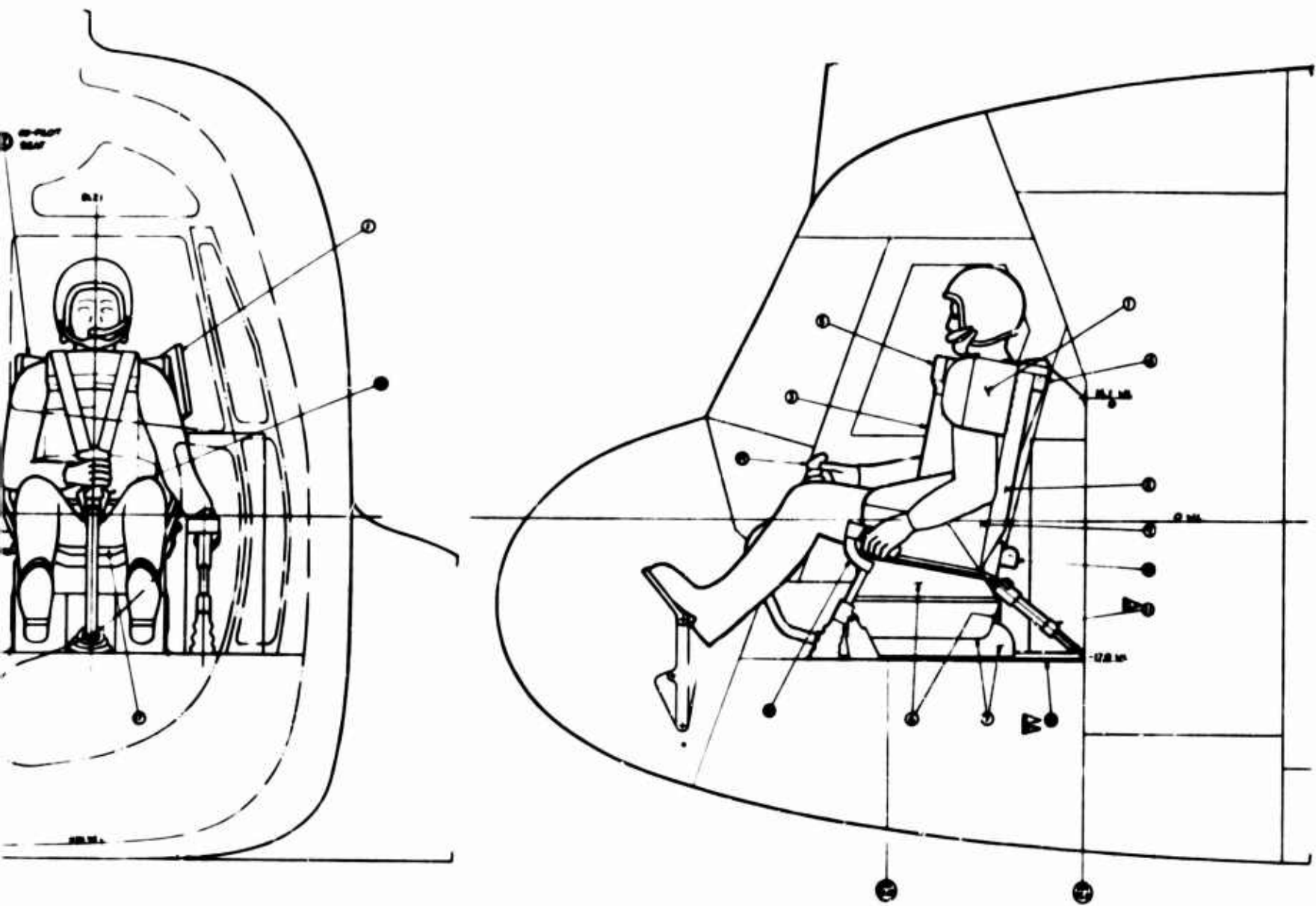
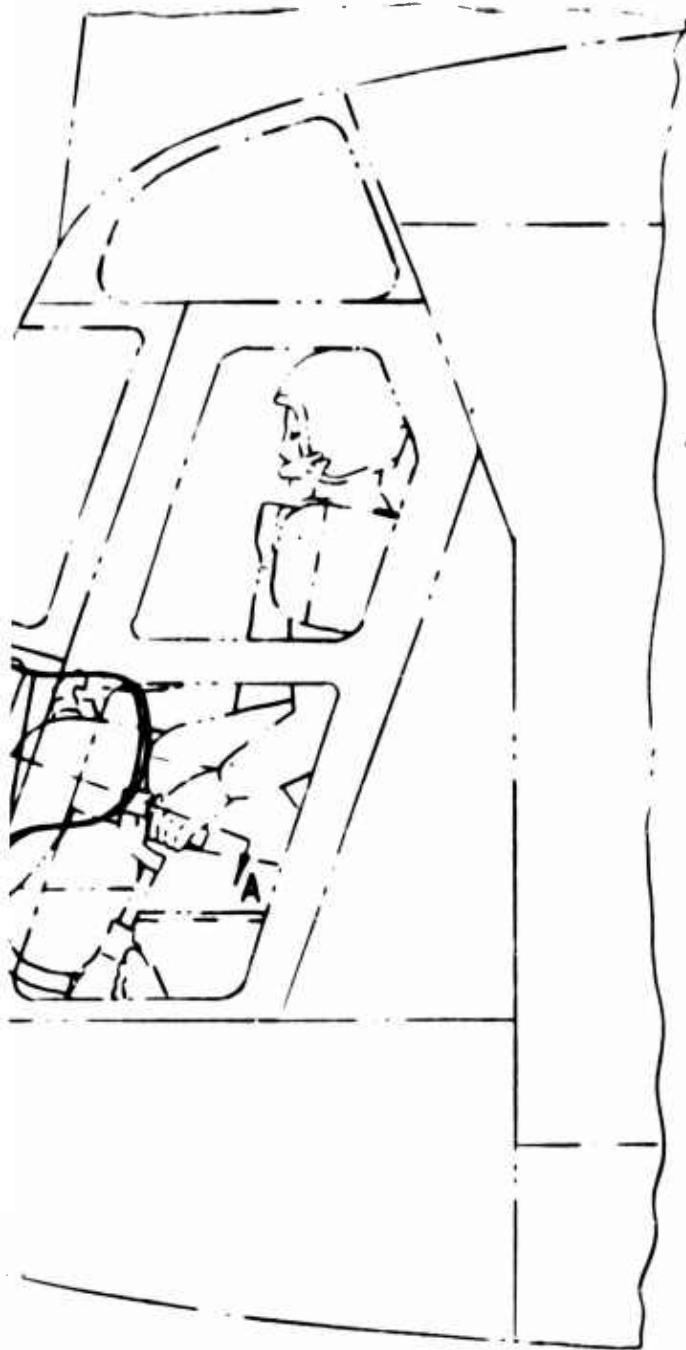

FIGURE 2 INBOARD PROFILE





REVISIONS					
BY	ZONE	LET	DESCRIPTION	DATE	APPROVAL

NOTES

- ① APPROXIMATE AREA SHOWN 2.25 SQ. FT./SIDE, AND IS CONSIDERED THE OPTIMUM PLACEMENT TO PROTECT THE LEGS AND HANDS.
- ② THE REAR PORTION OF THE PANEL MUST FOLD OUTWARDS DURING EMERGENCY EXIT.

**PRINT REDUCED
ONE HALF
INDICATED SCALE**

ART NO.	DESCRIPTION	STOCK SIZE	MAT'L	MAT'L SPEC.	U.T.S.	FINISH	TEMP. RANGE	CALC.	ACT.	CODE NO. FOR NEXT ASSEMBLY BLOCK	NOTE	REV. SYMB.
					1000			UNIT WT.				

LIST OF MATERIAL

SECURITY CLASSIFICATION

F - MPD HEAD FAR SIDE
 N - MPD HEAD NEAR SIDE
 DASH NO. FOR DIA.
 I - DRIVE AT INSTL.
 BASIC CODE
 D - DIMPLE
 NO. OF SHEETS DIMPLED
 C - CSINK
 DASH NO. FOR LENGTH
 RIVET CODE HAS 523

DRAWN BY	CHECKED	GROUP	STRESS	PROJ. ENGR.	CURT.
PHIL HANSEN					
		WEIGHTS	MAT'L & PROC.		F.A.A.

UNLESS OTHERWISE SPECIFIED
 DIMENSIONS ARE IN INCHES
 TOLERANCES ON
 DECIMALS ANGLES

X = .1 JX = .05 JXX = .010 J* = .5°

MAT'L	GOV. SPEC.	VEHIC. SPEC.
STEEL	ML-M-6878	13-4
ALUM.	ML-M-6889	13-9
MAG. CAST.	ML-M-6887	

HEAT TREAT

**DIAGRAM OF
SECONDARY ARMOR
PLACEMENT FOR
CH47A COCKPIT**

SCALE $\frac{1}{2}$

SK13796

CODE IDENT. NO. 81205 SHEET 1 OF 1

BLANK PAGE

sult in a deep compression of the cushion, causing a slack restraint system and permitting the undesirable "submarining" under the seat belt. A quick-release handle allows instant pop-out release of the shoulder harness and torso protector. The top of the torso protector is capped by a thick styrofoam pad that protects the face and chin. This pad has a thin (.010 inch) fiberglass shell for handling serviceability. The seat belt is released conventionally.

DETAIL DESIGN

SEAT ARMOR PROTECTION

Hard-face ceramic armor material and spall shield were used by Goodyear Corporation on the seat side panels, torso protector, and shoulder panels to minimize injury from fragments.

EVOLUTION OF SEAT CONFIGURATION

Maximum ballistic protection to the torso area of the seat occupant was achieved by an armored seat bucket and torso protector. The first approach to this problem was an attempt to take a conventional seat and apply the armor as an "add-on kit". Early effort to do this showed that there was a large weight penalty for this approach. In addition, there were control interference and seat strength problems.

The masking effectiveness of the CH-47A helicopter equipment and structure around the pilot was evaluated with the help of the Ballistics Research Laboratories personnel at Aberdeen Proving Ground, Maryland. The following opinions were formulated:

1. The electronics gear behind the copilot provides effective masking, permitting a slight reduction of copilot seat-back armor.

2. The controls behind the pilot are not dense enough to justify pilot-back armor reduction.
3. The under-floor controls and structure for both pilot and copilot could only be counted upon to give some ballistic tipping.

It became obvious that only varying amounts of tipping could be expected from the aircraft structure, but that the main protection would have to be accomplished by armor placement. Much effort was expended in an endeavor to achieve the maximum protection for a given area of armor. It was found necessary to place armor as close as possible to the torso for maximum efficiency.

Early layouts proposed the use of curved tiles mounted on curved backing, similar to those produced by Goodyear, shown in Figure 4a. This material had approximately 7 inches of radius on the inner face of the backing material. Two tiles 5.8 inches long having an arc of 5.8 inches each were used to accomplish a 90-degree bend for joints between adjacent flat panels. This concept was developed into a "wraparound" seat bucket and a matching "wraparound" torso protector. The latter was to be constructed from four curved tiles which would make up 180 degrees of arc. This arrangement would cover the torso from left arm to right arm horizontally, and from seat to chin vertically.

This arrangement gave greater efficiency than previously explored arrangements. The net saving in area for a curved corner from a square corner was 20 percent between adjacent flat panels. This concept was abandoned when the cost to manufacture was determined to be prohibitive.

Further investigation revealed that the same general configuration could be achieved by using flat bevel-edged tiles, shown in Figure 4b, mounted on kinked backing. Where a curved tile was used previously, it was replaced by a flat bevel-edged tile. The resultant effect was

BLANK PAGE

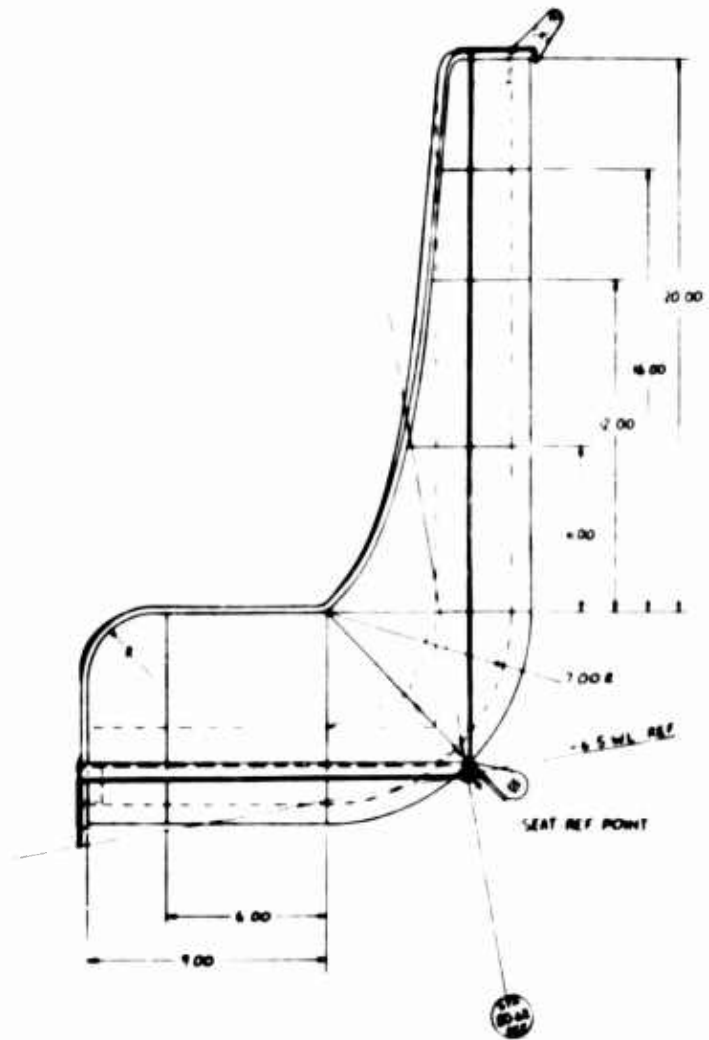
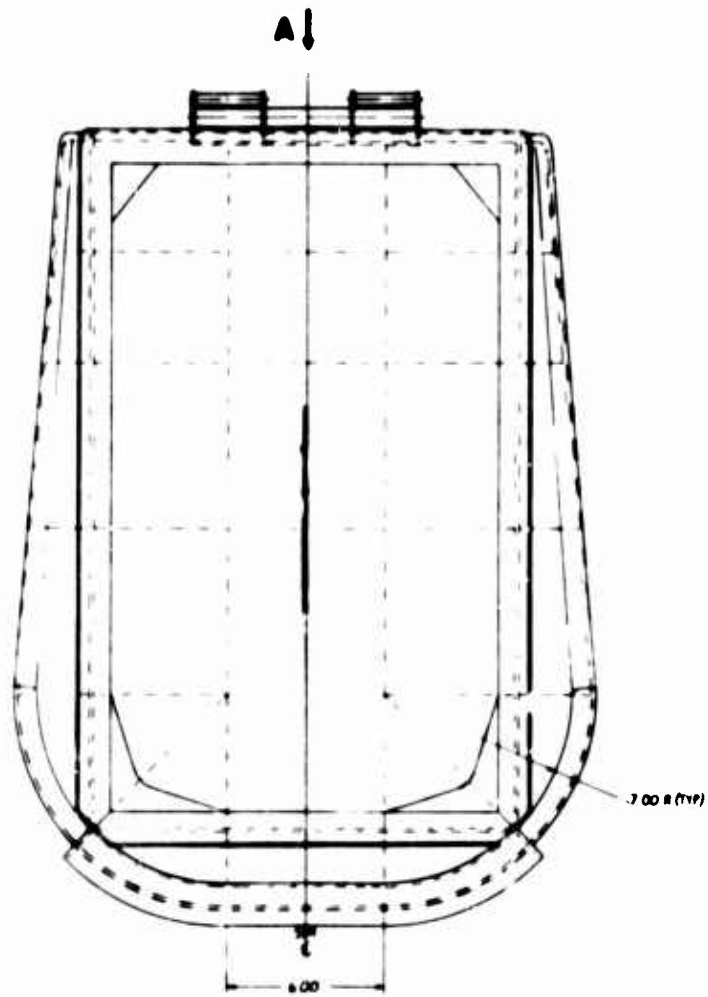

LEFT SIDE

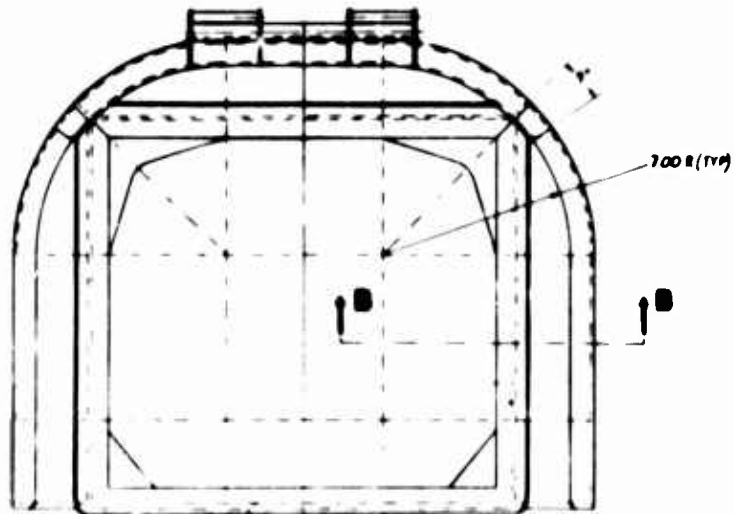

VIEW ON A

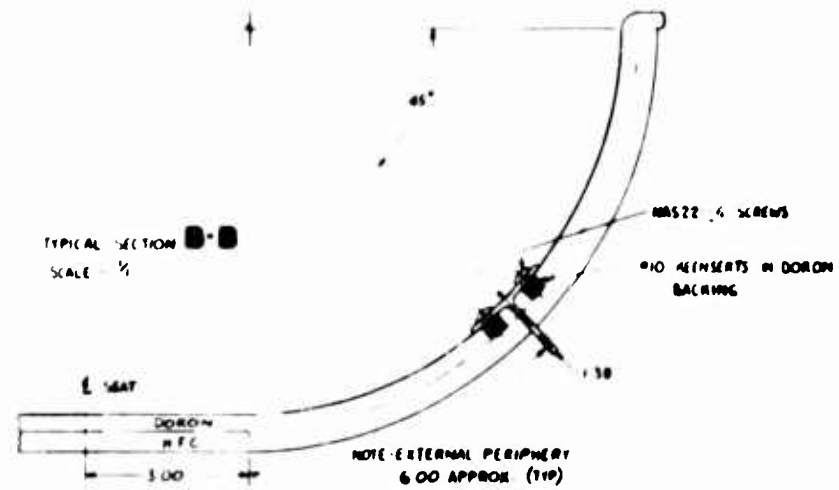

FIGURE 4a ARMORED SEAT BUCKET

REV	DATE	BY	CHKD	APP'D

EXPLANATORY DESIGN NOTES:-

- 3.1 THE SEAT TO CONSIST OF FOUR MODULAR PANELS WHICH ARE BOLTED TO A WELDED FRAME
- 3.2 THE MAIN PANELS ARE THE BUTT PROTECTOR AND THE BACK PROTECTOR AND ARE SIMILAR, DIFFERING ONLY IN LENGTH.
- 3.3 THE SIDE PANELS ARE GEOMETRICALLY SIMILAR TO THE MAIN PANELS AND HAVE ONLY TWO ATTACHMENT EDGES, THE THIRD EDGE BEING FREE.
- 3.4 THE PANEL ATTACHMENT BOLTS WILL BE PITCHED EQUALLY AND CONTINUOUSLY ALONG ALL FLANGES AND WILL NOT BE CLOSER THAN 1.00.
- 3.5 THE BASIC PITCH DISTANCE BETWEEN ADJACENT THE JOINTS WILL BE 6.00.
- 3.6 THE CURVED TILES WILL BE CURVED IN ONE PLANE ONLY AND WILL MATCH A LORON BACKING WITH AN INSIDE RADIUS OF 7.00. THERE WILL BE ONLY ONE HANDED DIAGONAL CURVED TILE TO SUIT ALL CORNERS. THE DORON BACKING WILL BE MITERED FROM 90° TO APPROXIMATELY 120° ALONG THE BUTT JOINT BETWEEN ADJACENT DIAGONAL CURVED TILES ON ALL THREE PANELS
- 3.7 ATTACHMENT OF THE ARMORED SEAT BUCKET ASSEMBLY WILL BE BY ADHESIVE BOND TO THE HONEYCOMB PEDESTAL AND CONTINUOUS PASTERING OF THE EXTENSION FLANGES TO THE OUTER CASING OF THE HONEYCOMB BLOCK.
- 3.8 A CONTINUOUS DORON LIP WILL BE PROVIDED AROUND ALL UNSUPPORTED PANEL EDGES.
- 3.9 THE TORSO PROTECTOR WILL BE SUPPORTED ON THE INSIDE CENTRE OF THE BUTT PROTECTOR AND SECURED BY A SUITABLE CLOSED EXTRUSION.
- 3.10 SEAT BELT ATTACHMENT POINT.
- 3.11 THE APPROXIMATE AREAS OF THE ARMORED PANELS IN SQ FT. ARE AS FOLLOWS:-

BACK PROTECTOR	3.30
BUTT PROTECTOR	1.93
LEFT SIDE PROTECTOR	1.08
RIGHT SIDE PROTECTOR	<u>1.03</u>
TOTAL	7.34 SQ FT.
- 3.12 SHOULDER HARNESS GUIDE BRACKET
- 3.13 SEAT ADJUSTMENT SCREW JACK PICK UP LUGS

WELDED FRAME ASSEMBLY

RIGHT SIDE PROTECTOR

SIDE PROTECTOR

BACK PROTECTOR

BUTT PROTECTOR

EXPLODED VIEW SHOWING PROPOSED
MANUFACTURING BREAKDOWN
SCALE 1/8

**PRINT REDUCED
ONE-QUARTER
INDICATED SCALE**

REV	DATE	BY	CHKD	APP'D	PROPOSED ARMORED SEAT BUCKET ASSY FOR LORON ATTENUATED PILOT & CO-PILOT SEAT FOR CH-67B HELICOPTER

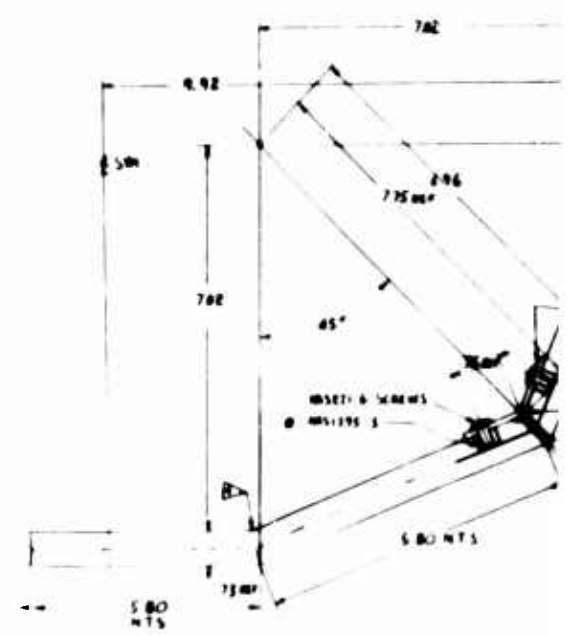
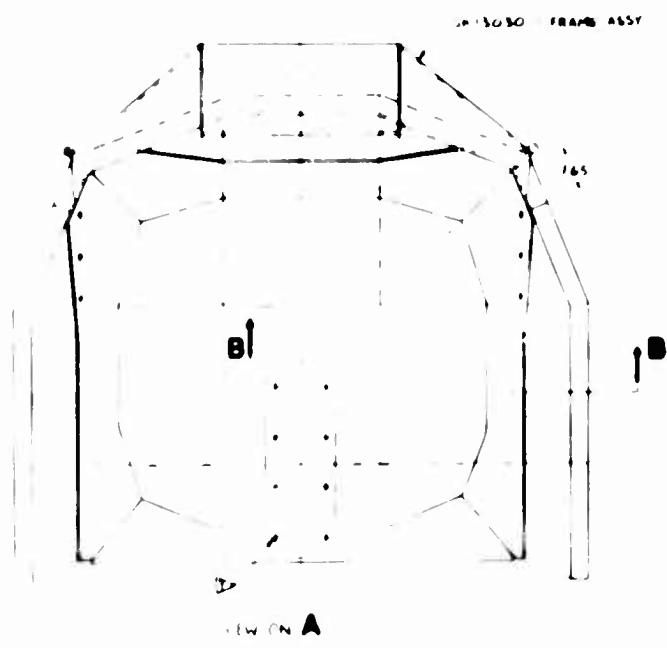
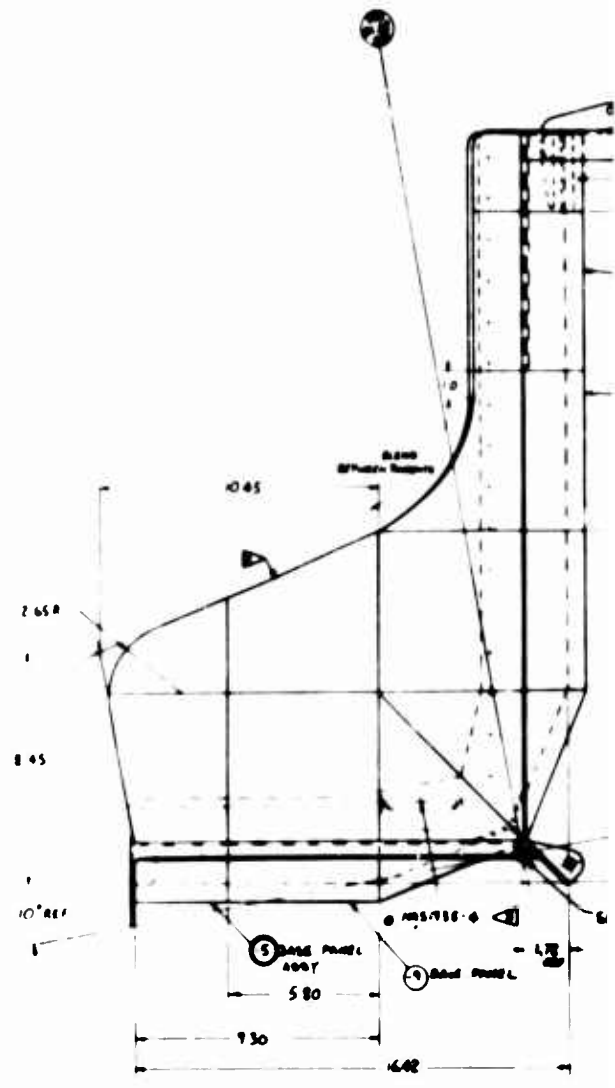
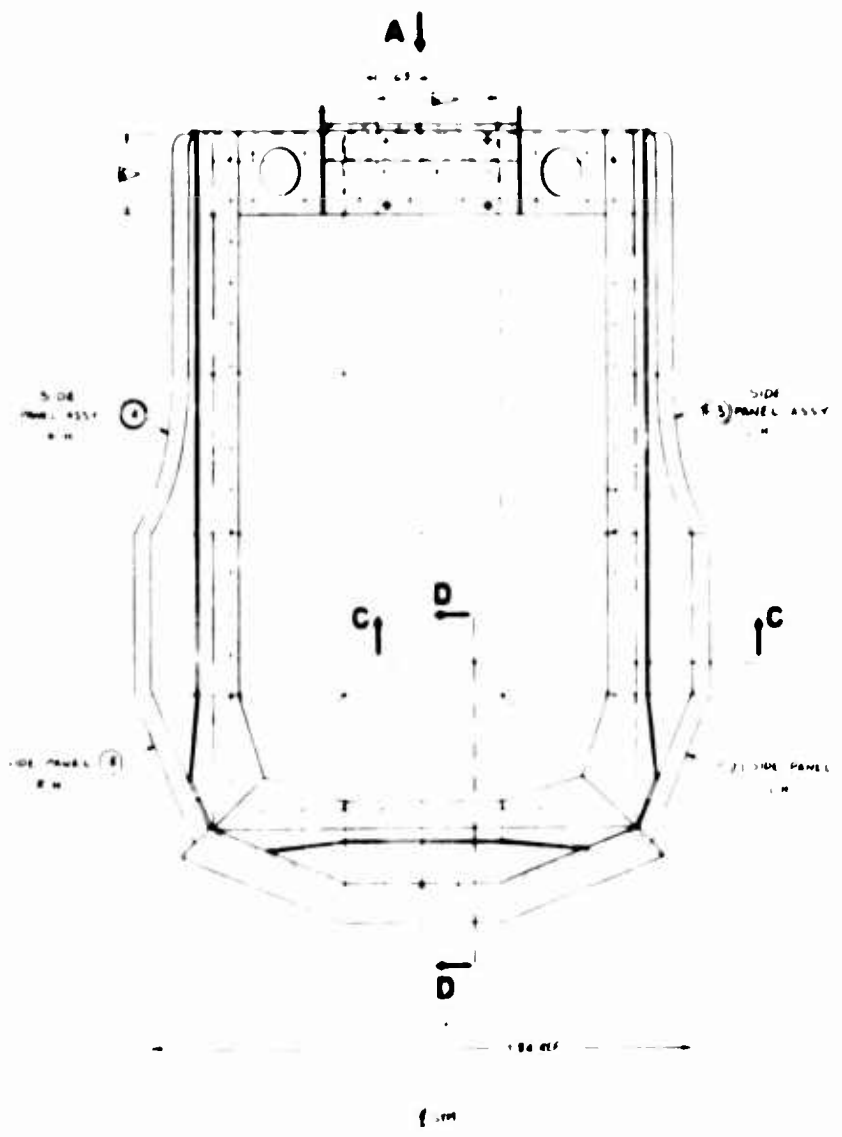
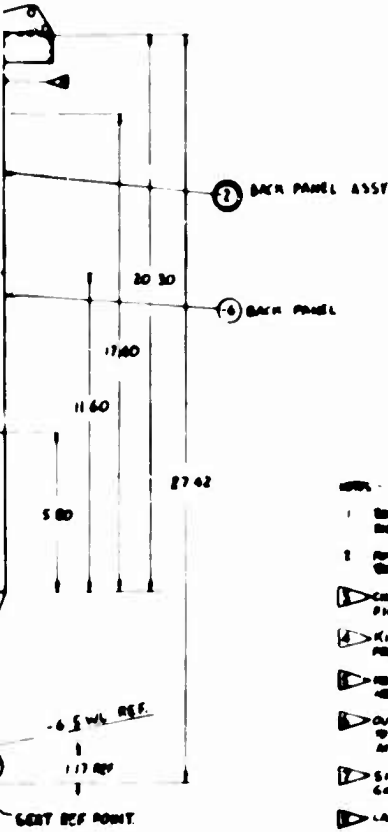

FIGURE 4b ARMORED SEA
15

REV		DATE	BY	CHKD	DESCRIPTION
1					ISSUED FOR PRODUCTION
2					
3					
4					
5					
6					
7					
8					
9					
10					



- NOTES:
- SEE DIMENSIONS TO BE READ IN CONJUNCTION WITH THE SEAT FRAME DIMENSIONS SK13020
 - POSITION OF HOLES TO BE LOCATED FROM THE SEAT FRAME SK13020
 - CHECKED SURFACES MATERIAL TO HAVE THE WELD FILLET IN FRAME
 - KNIFE EDGES IN ENTIRE PANEL TO BE FINISHED WITH THE SAME TYPE OF MATERIAL
 - HOLES MAY BE PURCHASED FROM THE SEAT FRAME OR FROM ANOTHER SOURCE - A 3 CAL
 - OVERS HOLES TO BE CHECKED IN THIS AREA TO ASSURE ACCURACY OF SEAT FOR ASSEMBLY IN SEAT ASSEMBLY
 - SIDE PANELS ONLY TO BE FITTED WITH CONCAVED SPALL BUILT
 - LAP BOLT ATTACHMENT FITTING LOCATION
 - THIRD POSITION ATTACHMENT FITTING LOCATION
 - MS13953 & MS13954 NUTS MAY BE USED IN PLACE OF MS13953 & MS13954
 - TOLERANCE ON APRON PERIPHERY 1/16

**PRINT REDUCED
ONE-QUARTER
INDICATED SCALE**

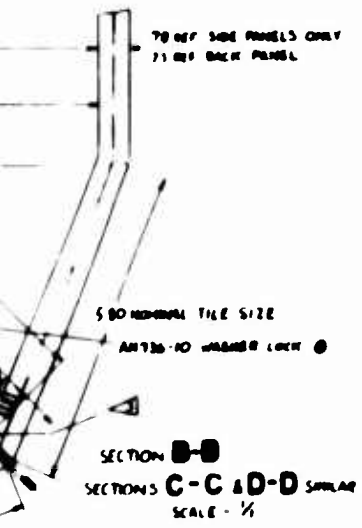

QTY	DESCRIPTION	UNIT	REMARKS
1	SK13020 FRAME ASSY		
3	MS13954 NUTS		
33	MS13953 NUTS		
41	MS13954 NUTS		
1	SK13020 SEAT PANEL		

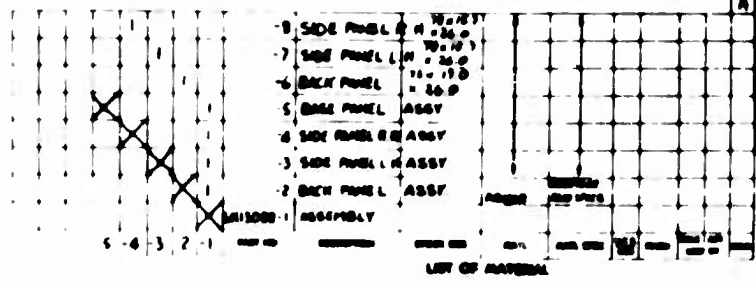

SK 13020	SEAT BUCKET ASSEMBLY	SEAT BUCKET ASSEMBLY	SK13020A
----------	----------------------	----------------------	----------

BLANK PAGE

to place a chord across each previously used 45-degree curved tile. Thus, two bevel-edged tiles would now produce a 90 degree bend between adjacent flat panels. A further saving in area of approximately 2 percent per corner was made with this concept.

A series of tiles, similarly beveled on kinked backing, were assembled to make up a torso protector. This achieved commonality in basic tile shapes, minimizing manufacturing costs. The height of the torso protector was designed to a maximum for a man in the 5th percentile. The "wraparound" chest contour was made a minimum for a man in the 95th percentile. These concepts were adopted to reduce cost because a mock-up study indicated that, ultimately, a series of torso protectors would be necessary to fit the man in the 5th, 50th and 95th percentiles. It was possible that three sizes would accomplish the torso protection task. A crewman would then select his torso protector in the same manner that he now selects his flying helmet.

A mock-up seat bucket and torso protector were fabricated to check the armor panel geometry for complete torso coverage, as shown in Figure 5. The original mock-up was evaluated by Vertol Division of The Boeing Company and by TRECOM.

As a result of the evaluation, the area of side armor was increased by raising the side panels until they were under the arms of the man in the 5th percentile. Originally, the mock-up was fitted with fixed shoulder armor. This was increased in size and made adjustable to the shoulder height of the occupants. Subsequent mock-up modifications indicated that complete overlapping of armor elements was possible for 100 percent side protection of the torso, shown in Figures 6a, 6b, 6c, and 6d.

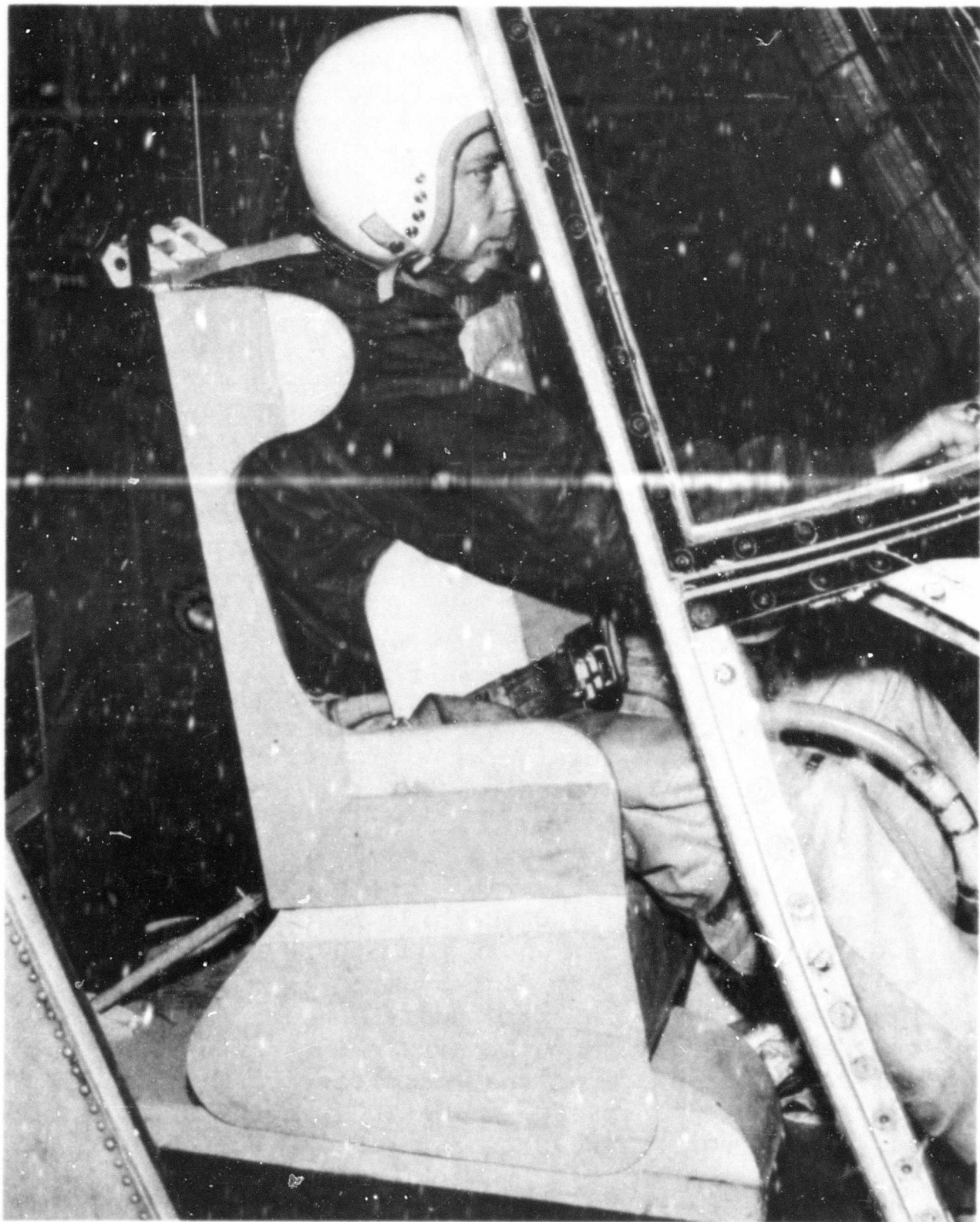

FIGURE 5. INITIAL SEAT MOCK-UP IN CH-47A HELICOPTER

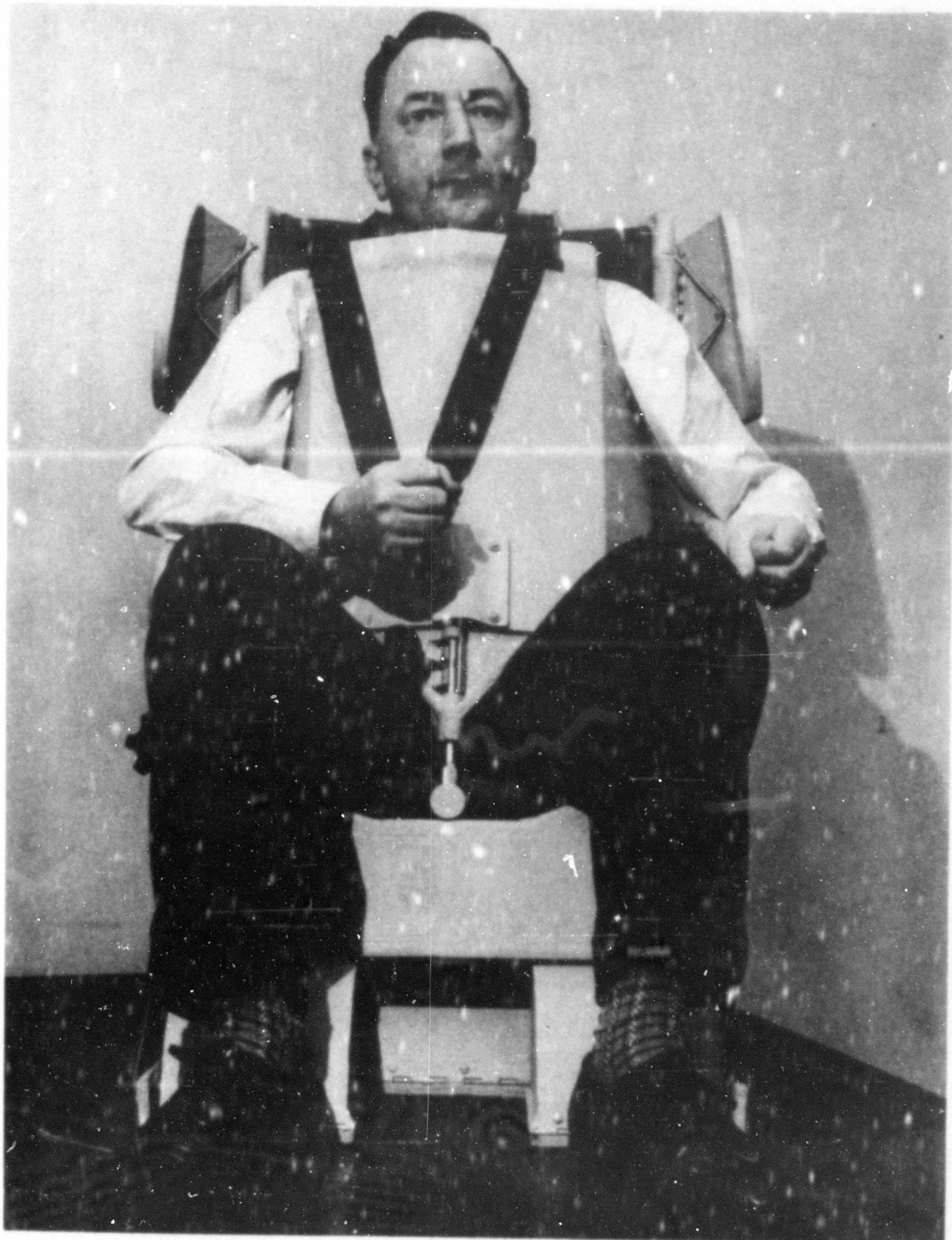

FIGURE 6a. SEAT MOCK-UP - FRONT VIEW

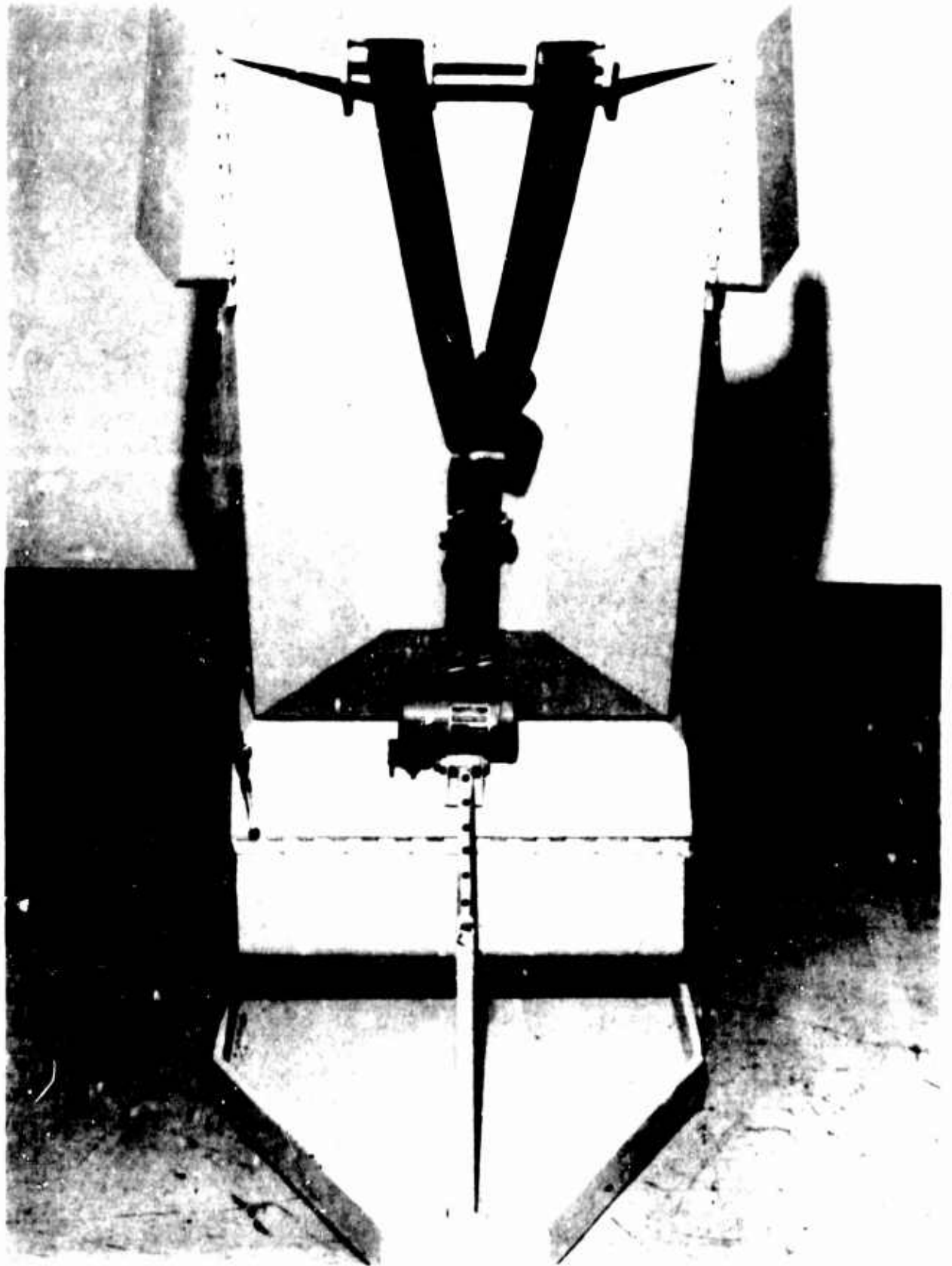

FIGURE 6b. SEAT MOCK-UP - BACK VIEW

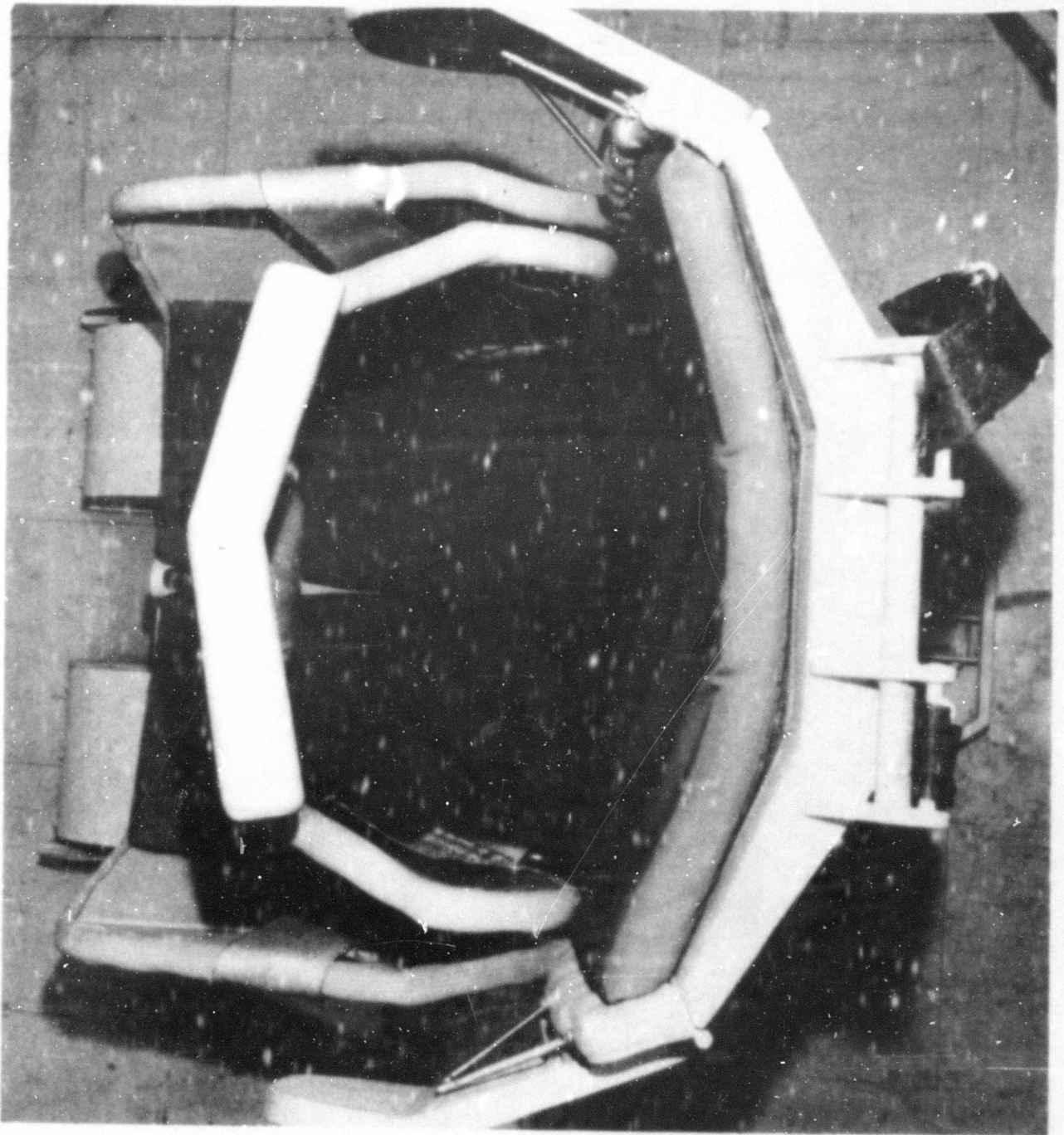

FIGURE 6c. SEAT MOCK-UP - PLAN VIEW

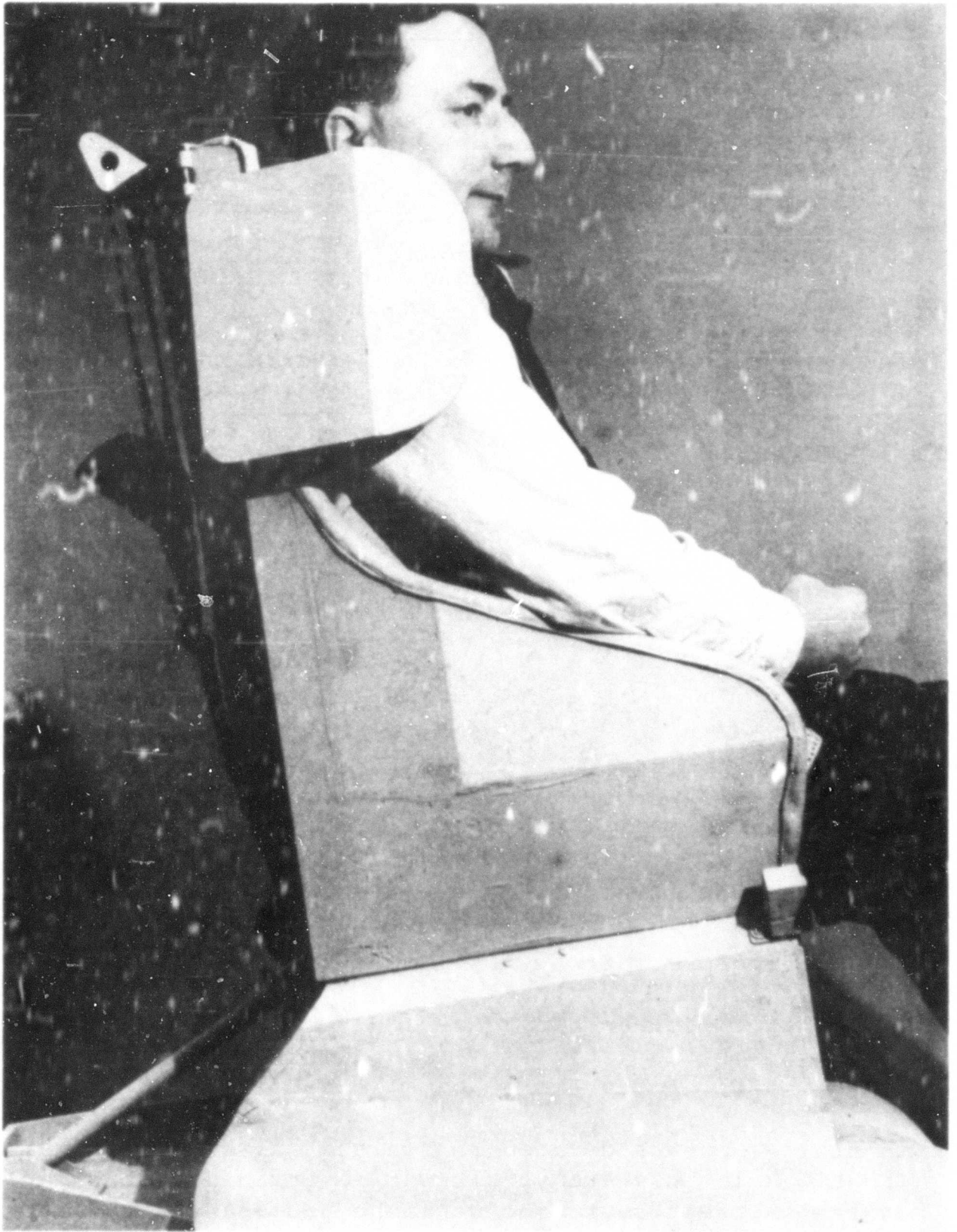

FIGURE 6d. SEAT MOCK-UP - SIDE VIEW

INTEGRATION OF ARMOR MATERIAL AS SEAT STRUCTURE

A lightweight seat frame was developed which could be placed on the inside of the armor panels. Structural integrity was obtained by placing a stabilizing flange between adjacent armored panels; this flange protruded to the outside, providing attachment to the external seat support structure. This system produced the minimum number of panels — back, seat, left side, and right side.

Fastening of the armor to the frame was accomplished by placing standard screw inserts into the backing material, thus keeping all securing items on the inside of the seat bucket. The seat cushion, which was designed to cover the inside of the frame, prevented the screw heads from causing discomfort to the seat occupant. This concept gave a high degree of structural integrity, particularly for side and rearward crashes.

MECHANICAL AND KINEMATIC ENERGY ABSORPTION STUDIES

Figure 7 shows a design using tube and die load limiters combined with seat-adjust kinematics that would approximate the requirements shown in MS33575 (Dimensions, Basic, Cockpit, Helicopter). This sketch shows spring-loaded counterweight struts used to compensate for the seat and armor weight based on a parallel link system.

This system could have been made dynamically optimum only for one seat position and for the weight of one man. Raising or lowering the seat from its mid-position would have had an adverse effect on the dynamic loading induced on the seat occupant in a vertical crash. Adjusted to the high position, the seat occupant would experience approximately twice the g loads felt at the mid-position.

Initially, it was decided to use the existing seat rail locations in this study. It was determined that some additional seat restraint would be necessary to prevent forward pitching of the seat and occupant. Figure 8

shows the attempt to overcome the undesirable features found in the study shown in Figure 7. This study followed the same general concept but included a self-compensating linkage to adjust vertical attenuated crash load levels in a favorable sense based on the probability that the smaller man will tend to adjust his seat up and forward. Also, it added a tie strap on the bulkhead behind the seat to reduce forward pitching. The studies shown in Figures 7 and 8 used a deep, crushable, energy-absorbing cushion on the seat pan to provide part of the energy absorption stroke. However, the seat pan caused a severe interference problem with the pitch/roll control. Both studies necessitated a detrimental cutaway in the seat pan armor and a tunnel to cover the control mount for maximum seat stroke. It was assumed that the side loads would be taken out through large pads which were in contact with the side armor panels. These in turn would pass the loads into the support structure mounted on the cockpit floor. Efforts were then made to reduce the seat width so that it would attach to existing mounting rails. This design was found to be impractical due to the complex load paths with resulting excessive weight.

Attempts were then made to incorporate some of the desirable features shown in Figures 7 and 8 by using an "A" frame mounted seat. This design is shown in Figure 9. An effort to approximate a parallel link system was made using a link with an arc tangential to the rear leg of a floor-mounted "A" frame. The forward leg of the "A" frame contained a tube and die load limiter; the rear leg supported the seat adjustment frame. Counterbalance was achieved by tension springs. The upper link and the adjustment tube on the "A" frame provided an approximation to a parallel link system minimizing the seat-back tilt during seat adjustment. The seat-back link attached to the bulkhead at the seat center because of the gangway between the pilot and copilot stations. This design presented the difficult problem of making seat attachment to the armored back panel. Armored

BLANK PAGE

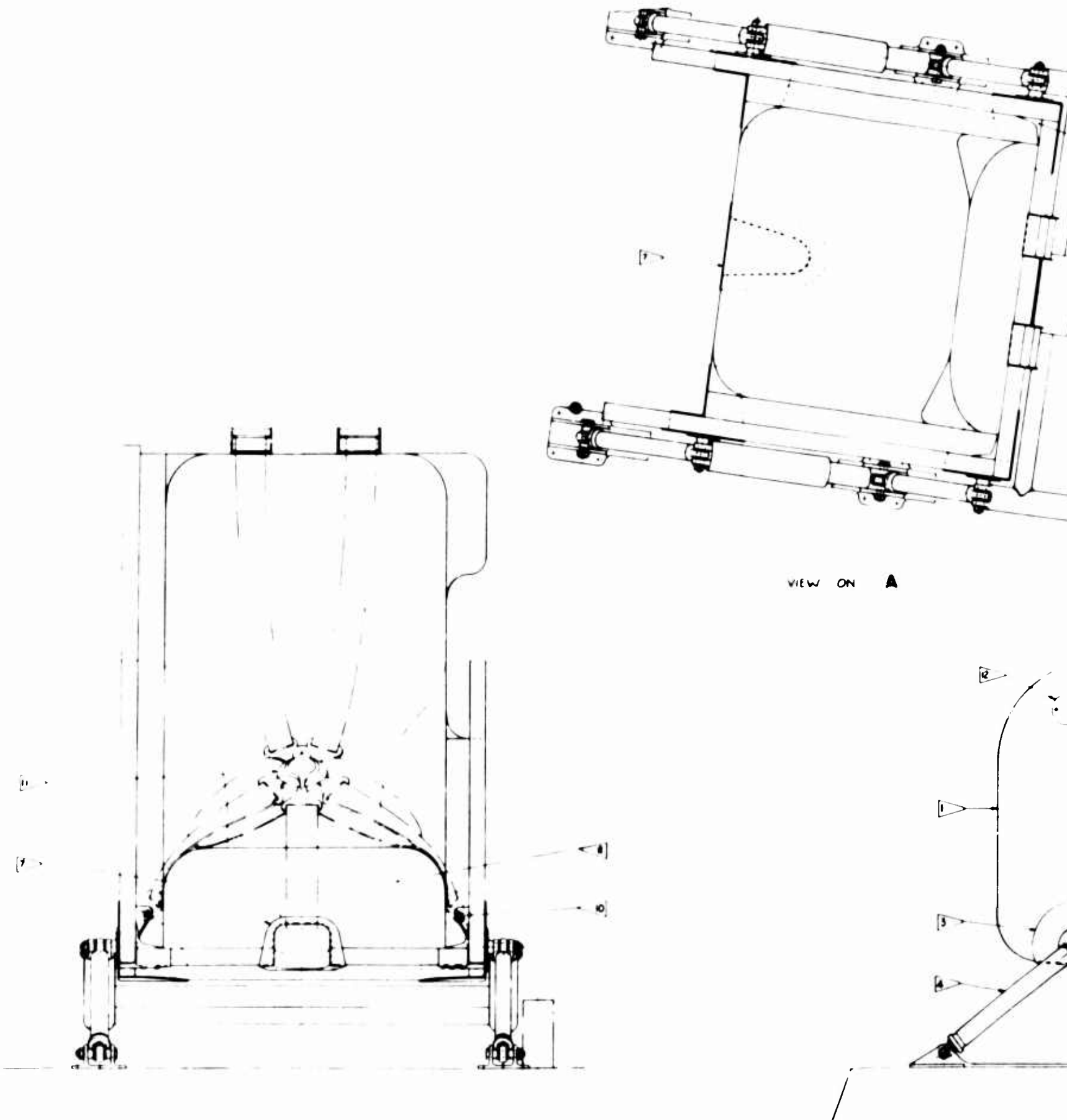

VIEW ON A

FIGURE 7 TUBE AND DIE FLOOR

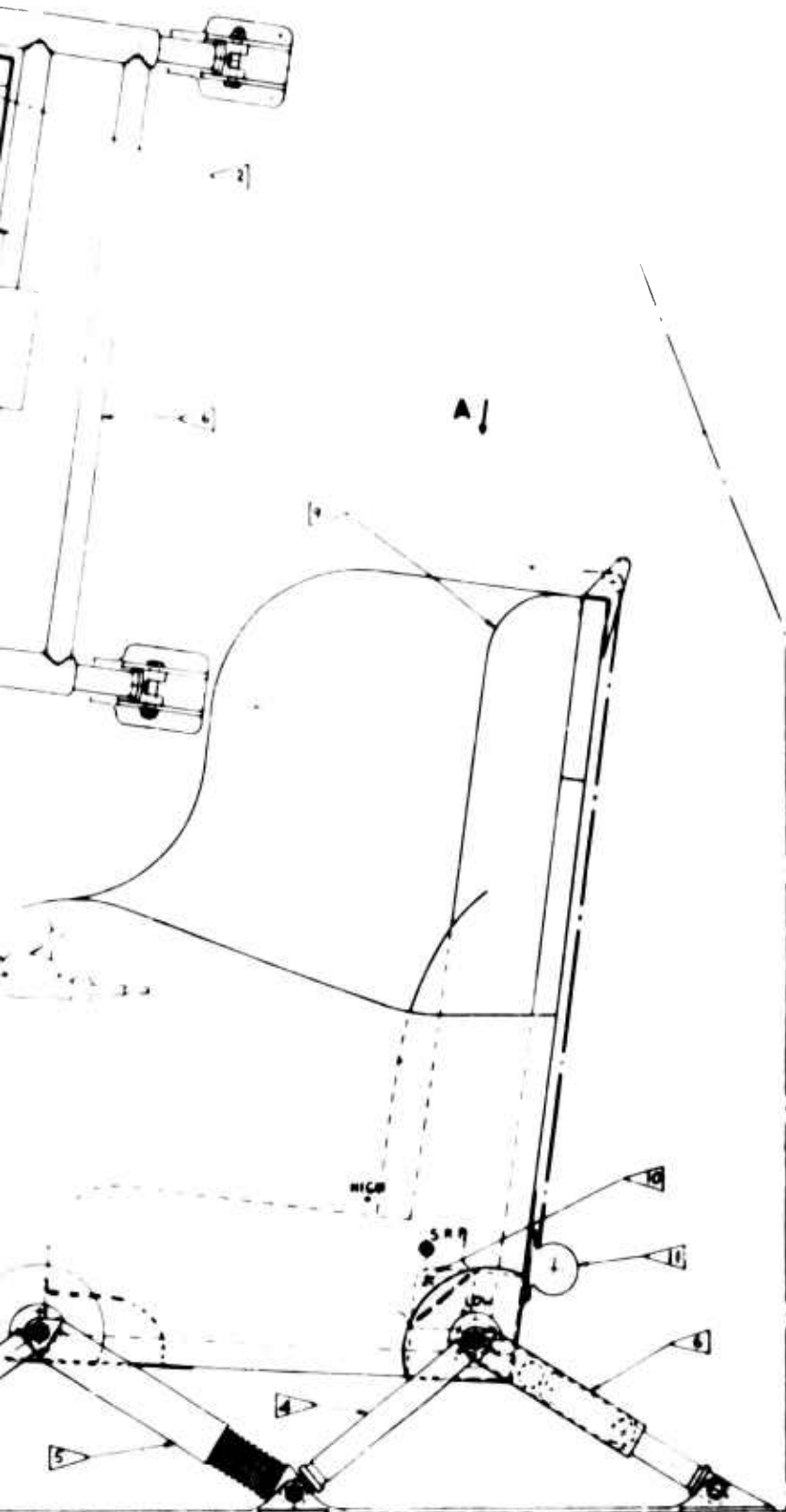

DESIGN NOTES:-

- 1 THE SEAT STRUCTURE TO CONSIST OF H.F.C ARMOR MATERIAL.
- 2 THE ARMORED PANELS TO BE BONDED TOGETHER WITH WEDGED SHAPED (DIAGON) ANGLES OR EQUIVALENT SUITABLE MATERIAL.
- 3 ALL SEAT SUPPORT FITTINGS TO BE ATTACHED TO LARGE AREA GUSSET PLATES SUITABLE FOR BONDING TO THE ARMORED FACE OF THE H.F.C MATERIAL.
- 4 THE AFT SLOPING SUPPORT LINKS ARE TO BE FITTED WITH COMPRESSION CRASH ATTENUATORS AND SELF ALIGNING END FITTINGS TO ENSURE THAT THE TUBES DO NOT BUCKLE WHEN THE CRASH ATTENUATORS ARE OPERATED.
- 5 THE SEAT COUNTERBALANCE SPRING STRUT IS TO BALANCE OUT THE SEAT WEIGHT ONLY; THIS BEING DICTATED BY LACK OF SPACE IN THIS AREA THE UPPER AND LOWER FORKS AND SLIDING TUBES TO BE DESIGNED TO TAKE A TOTAL OF 30% OF THE MAXIMUM SIDE LOAD WITHOUT FAILURE ALL PARTS OF THIS STRUT TO BE COATED WITH DRY FILM LUBRICANT TO REDUCE FRICTION IN NORMAL OPERATION.
- 6 THE SEAT ADJUSTMENT BRACE AT THE REAR OF THE SEAT TO BE DESIGNED TO TAKE 70% SIDE LOAD AND PROVIDE SEVEN (7) ADJUSTMENT POSITIONS THE LOWER PORTION OF THIS MECHANISM TO INCLUDE A TENSION ATTENUATOR WHO'S STROKE WILL EQUAL THE MAXIMUM SEAT ADJUSTMENT A STOP TO BE FITTED TO ENSURE THAT THE MEMBERS DO NOT PART AT THE END OF THE STROKE THUS CONTAINING THE SEAT.
- 7 A CAVITY TO BE PROVIDED AT THE FRONT OF THE SEAT PAN TO FIT OVER THE PITCH ROLL CONTROL IN THE EVENT OF A CRASH WHEN THE SEAT PAN IS FLAT ON THE FLOOR. THIS ENSURES THAT THE FULL AVAILABLE SEAT STROKE IS UTILIZED. THE CAVITY FITTING TO BE DESIGNED TO TERMINATE THE CROTCH STRAP.
- 8 THE SEAT PAN CUSHION TO BE MADE FROM ENERGY ABBORBANT MATERIAL AND DESIGNED TO PROVIDE AT LEAST 5 INCHES OF CRASH ATTENUATION THE CUSHION TO BE ATTACHED WITH VELCRO HOOD & PLE TAPE; ONE ELEMENT TO BE BONDED TO THE DOWN.
- 9 THE SEAT BACK CUSHION TO BE SIMILAR TO THE SEAT PAN CUSHION WITH RESPECT TO MATERIAL AND ATTACHMENT, AND PROVIDE AT LEAST 2.5 INCHES CRASH ATTENUATION. THE UPPER PORTION OF THE CUSHION TO BE CONTOURED AFT TO ALLOW FREEDOM FOR THE ELBOW AND UPPER ARM WHEN PULLING BACK ON THE R.H PITCH ROLL CONTROL & L.H THRUST CONTROL THE LOWER PORTION OF THE CUSHION TO BE CONTOURED FORWARD TO CENTRE THE OCCUPANT WITHIN THE SEAT.
- 10 THE SEAT BELT ATTACHMENT FITTINGS TO BE MADE INTEGRAL WITH THE REAR SEAT SUPPORT FITTINGS THIS FITTINGS TO BE INSERTED BETWEEN THE JOINT OF THE THREE ADJACENT H.F.C PANELS AND CORNER JOINT ANGLES AND BONDED.
- 11 THE SAFETY BELT ASSEMBLY AND SHOULDER HARNESS TO INCLUDE A TYPE MA-5 OR MA-6 INERTIA REEL SUITABLY MOUNTED ON A LARGE AREA BONDED PLATE.
- 12 THE INERTIA REEL RELEASE AND SEAT ADJUSTMENT LEVERS ARE TO BE FITTED ON THE OUTSIDE OF THE R.H ARMORED PANEL.
- 13 THE AREAS OF THE ARMORED PANELS SHOWN ARE AS FOLLOWS:-
L.H PANEL 5.20 FT², R.H PANEL 5.21 FT², PAN PANEL 3.03 FT²,
BACK PANEL 4.02 FT² TOTAL = 15.46 FT².
- 14 TARGET SEAT WEIGHT

ARMOR	= 135 LBS
SUPPORT MECHANISM, CUSHIONS, AND ACCESSORIES	= 25 LBS
TOTAL	<u>= 160 LBS</u>

DESIGN NOTE: CONTINUED ON SHEET

**PRINT REDUCED
ONE-QUARTER
INDICATED SCALE**

LAYOUT OF ARMORED CRASH ATTENUATED PILOT/CO PILOT SEAT FOR CH-53 HELICOPTER		
DATE: _____ DRAWN BY: _____ CHECKED BY: _____	PART NO: _____ REV: _____	5-592773

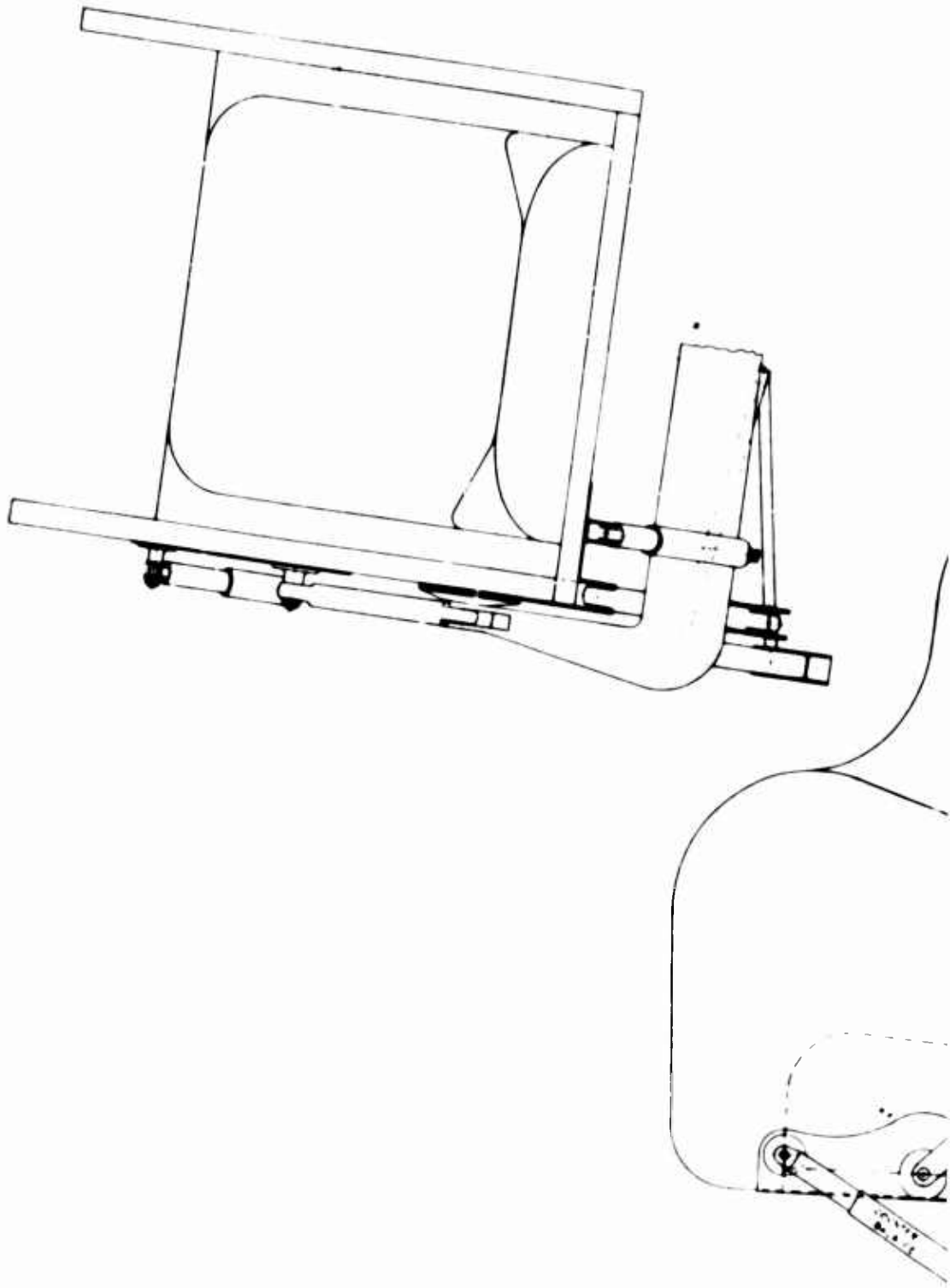
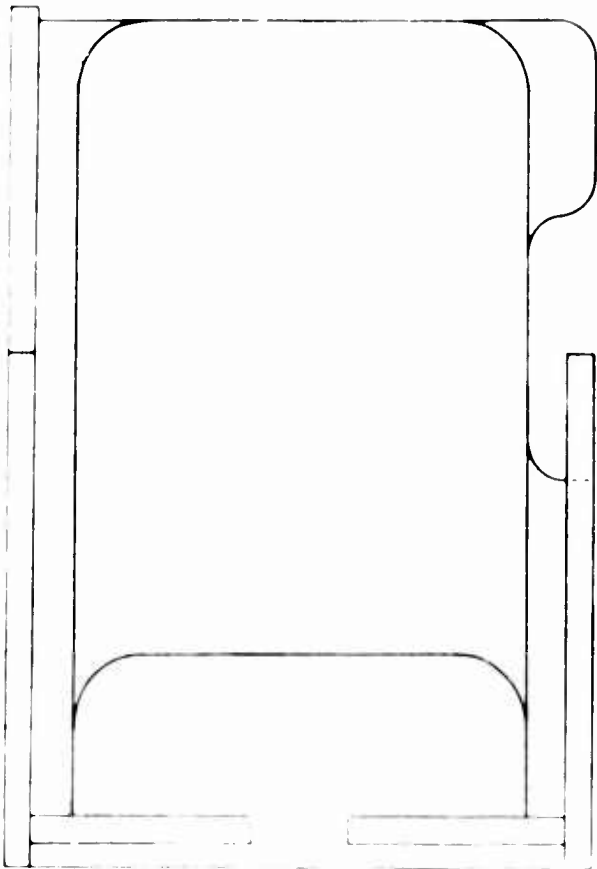
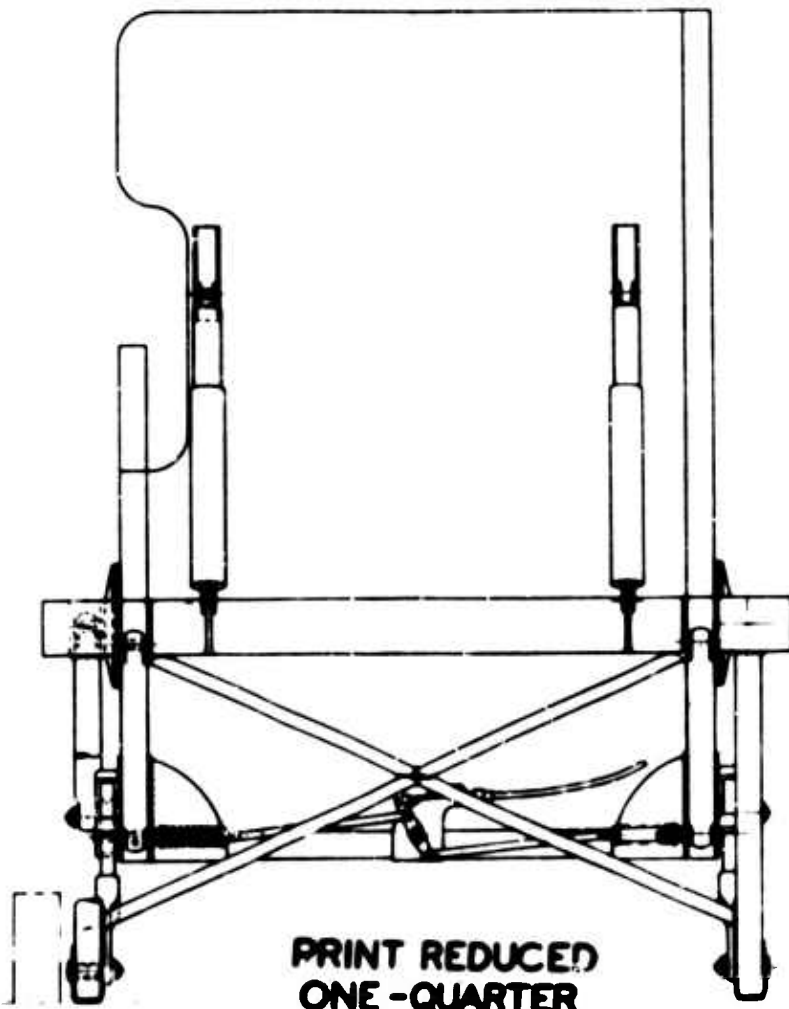
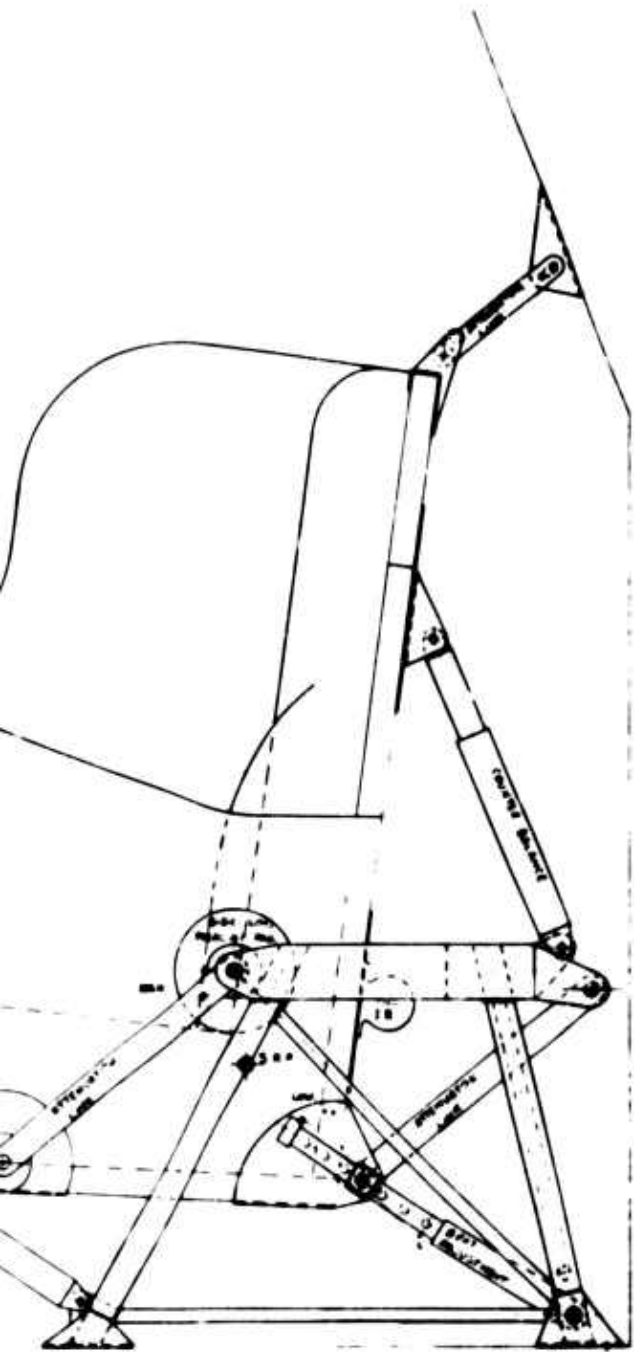

FIGURE 8 TUBE AND DIE HANGING SEAT S



PRINT REDUCED
ONE-QUARTER
INDICATED SCALE

TITLE TUBE AND DIE MACHINING SEAT SUPPORT.	DATE 11/1/54	DRAWN BY J. W. BROWN	CHECKED BY J. W. BROWN
---	-----------------	-------------------------	---------------------------

SUPPORT

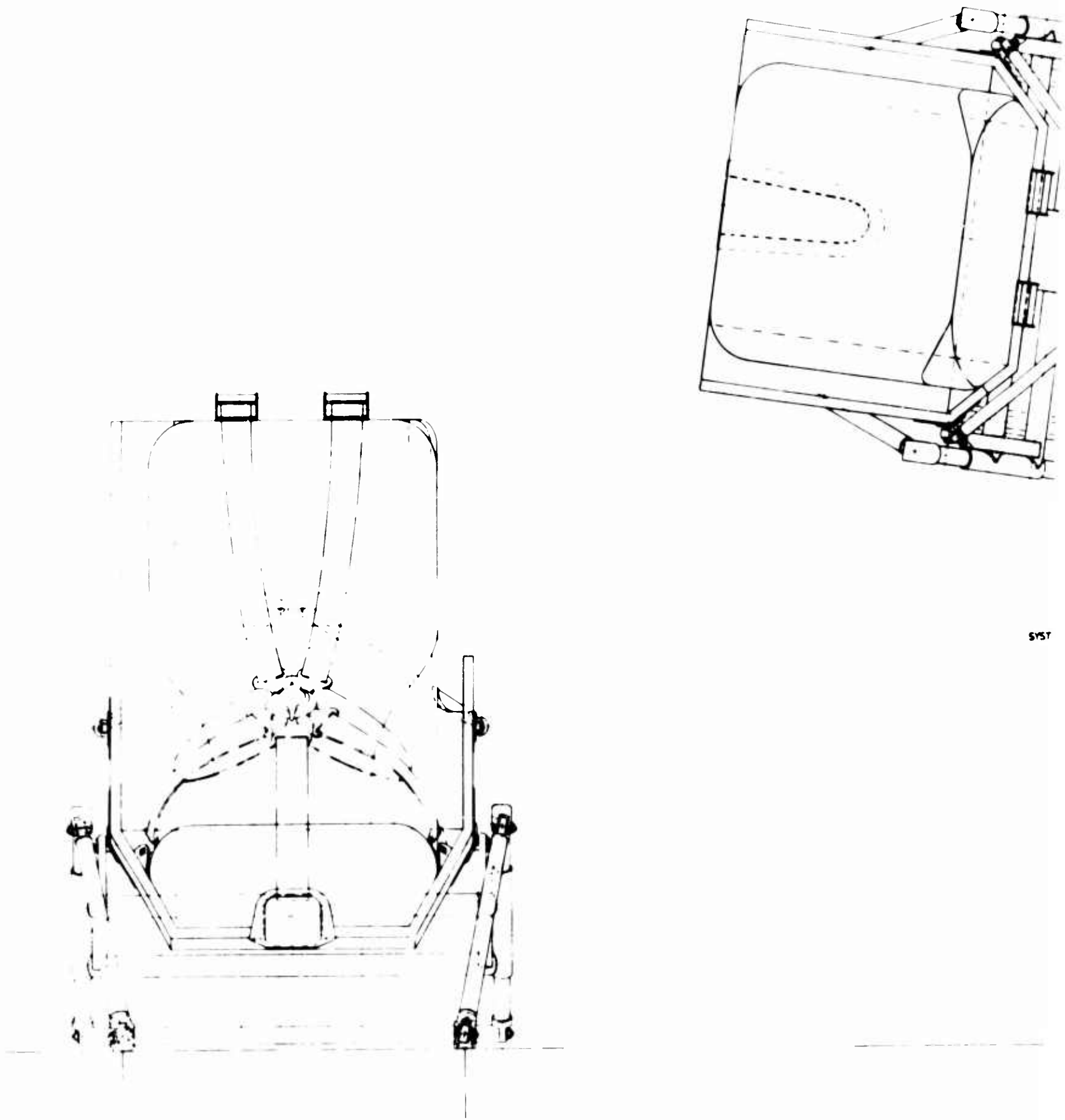

5757

FIGURE 9 "

BLANK PAGE

facets were introduced at the corners of the seat pan and back to reduce the overall seat width. This made it possible to mount the seat back links to the side facets just under the pilot's armpits. This concept had greater advantages than previous concepts. Attempts were made to show that this concept was compatible to all the minimum design parameters.

The dynamic analysis showed this concept to be unstable in the forward and side 45 g crash cases. Also, it showed that a large load would be introduced into the upper forward restraint strap. The vertical crash analysis indicated that the load limiters were sensitive to forward accelerations. The armor shape shown in Figure 9 used sloping facets at the corners of the panels, which led to the final adoption of the close-fitting seat bucket described in the "Armor Placement" section.

Previous seat support studies had one weakness in common, namely, that of concentration of the retention loads. In attempting to overcome this problem, the use of Trussgrid honeycomb support structures was investigated, as shown in Figures 10a and 10b. Early investigations showed that it was difficult to make seat adjustments with this type of support.

The design adopted used three diagonally loaded blocks that formed a parallel link system driven by a control floor-mounted screw jack. Figure 11 shows the predicted load-limiting behavior of this concept for seat occupants of various sizes with the seat at various adjustment positions. The basic load-stroke curve is shown in Figure 12 and is derived from AVSER crash test data for the H-25 and H-21A helicopters. This curve expresses seat vertical energy requirements in excess of fuselage crushing energy absorption. The superimposed points represent predicted crash behavior of the armored seat with various weights of men with the seat adjusted to all possible extremes. The points fall on, or to the right of, the curves, which indicates that the man/seat mass would be brought

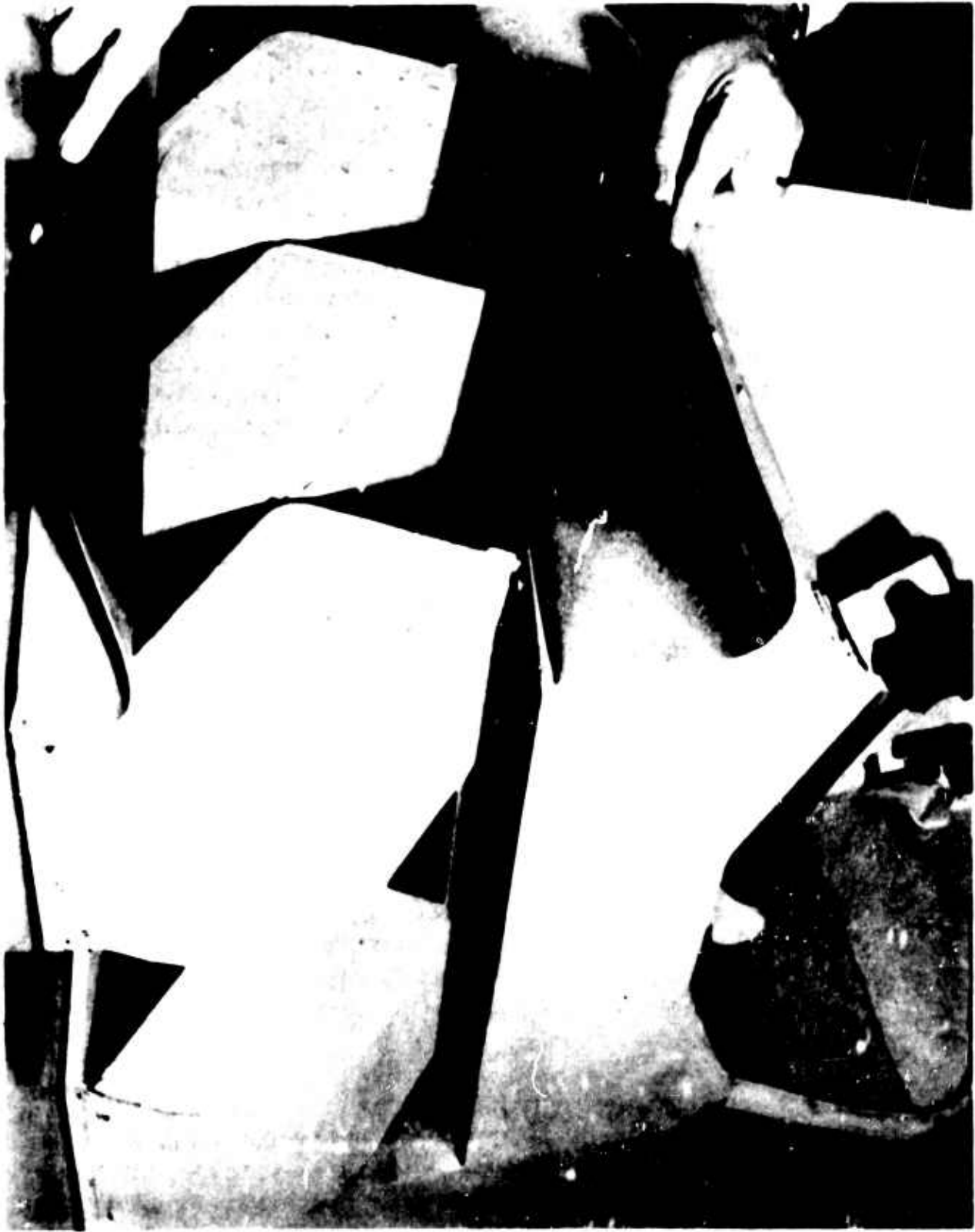

FIGURE 10a. SEAT BASE MOCK-UP - FORWARD SIDE

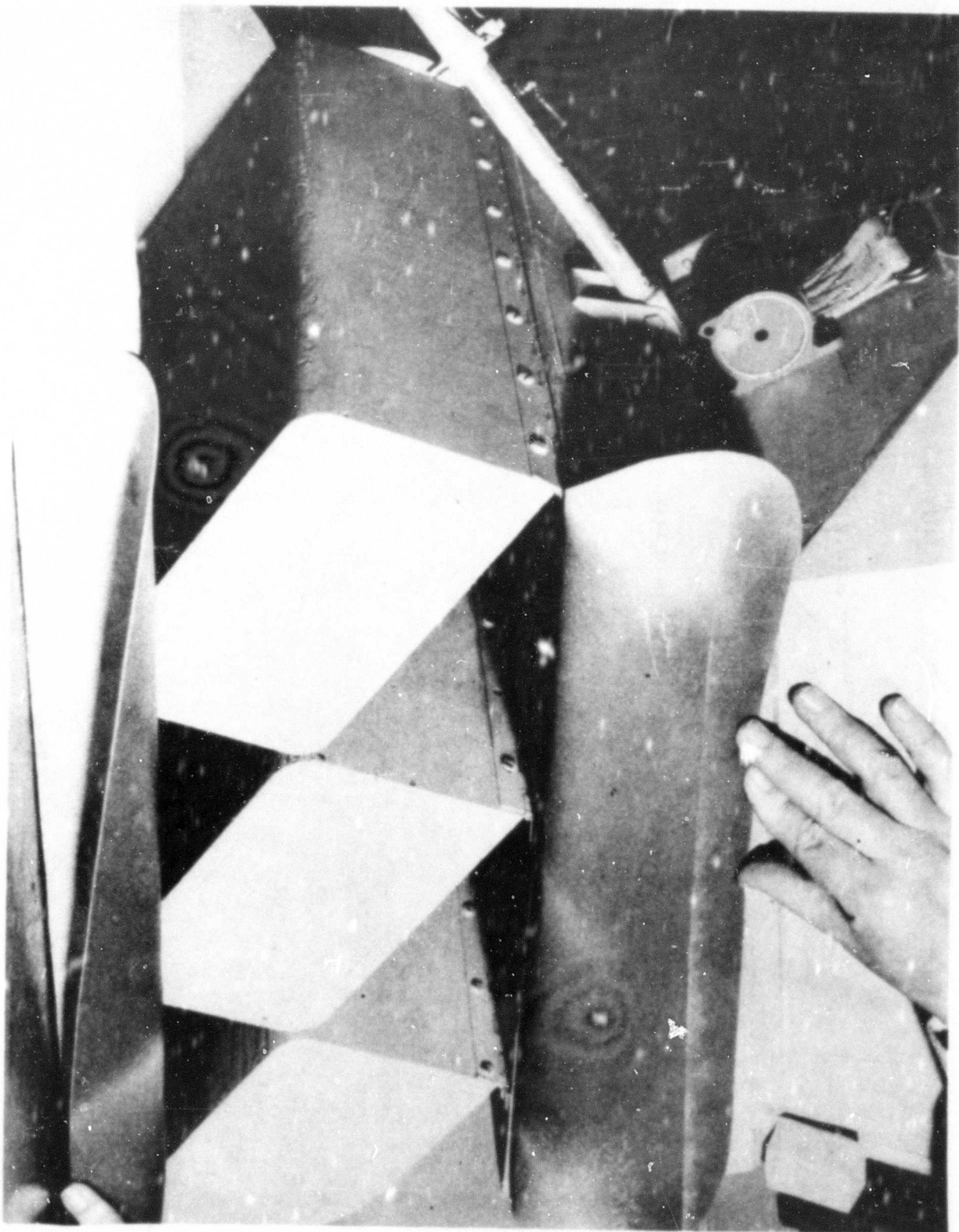
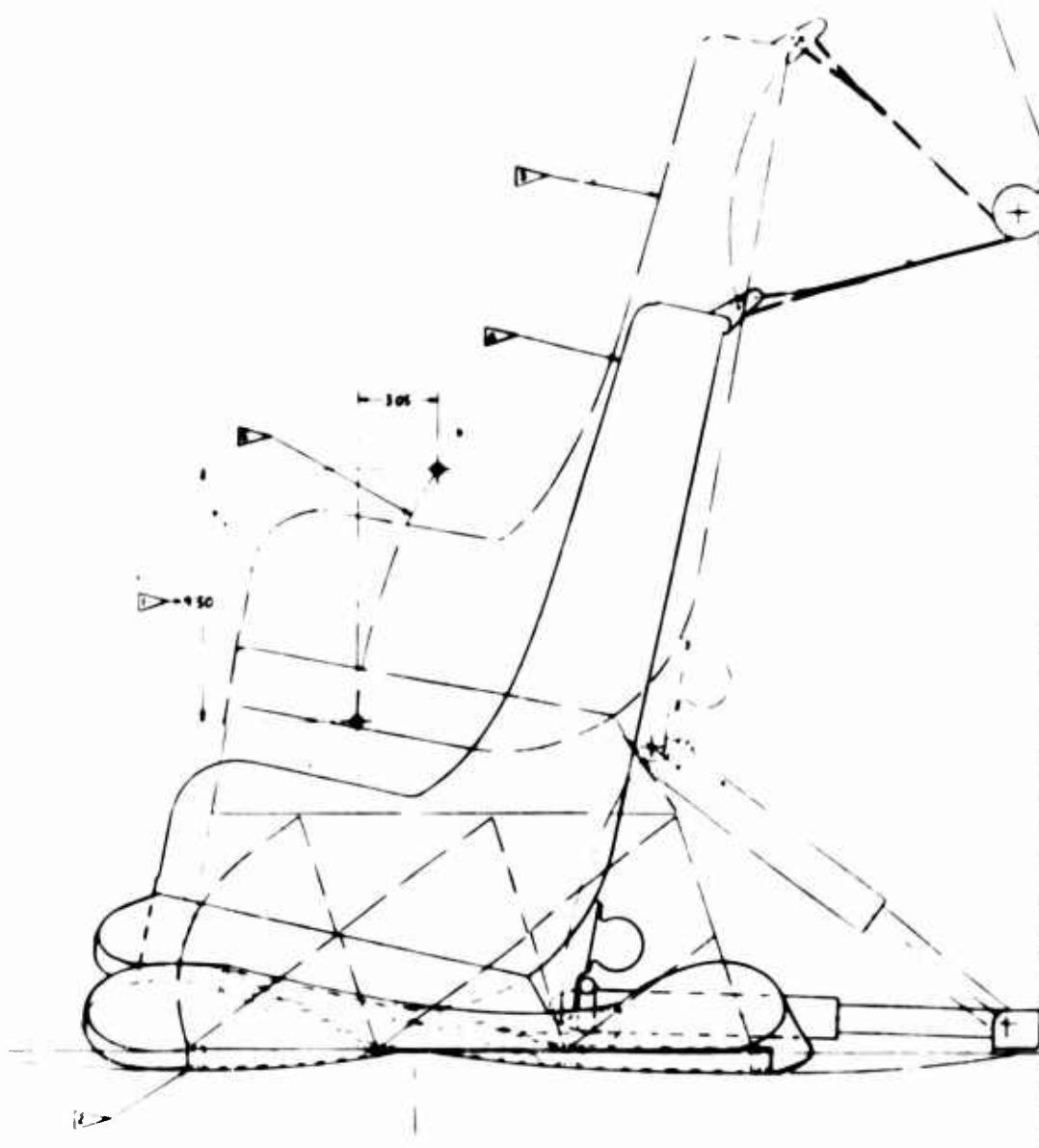
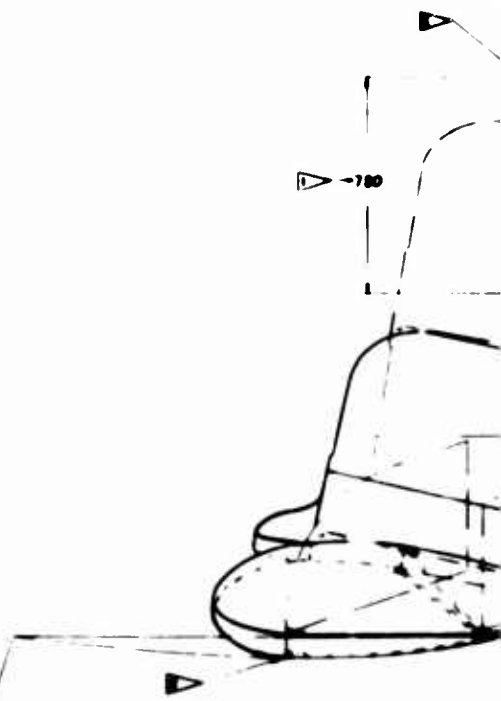

FIGURE 10b. SEAT BASE MOCK-UP - REAR SIDE



SEAT ADJUSTED FOR 5% MALE MAN AT 135 LBS



SEAT ADJUSTED FOR 5% FEMALE MAN AT 120 LBS



FIGURE 11

EXPLANATORY DESIGN NOTES :-

- 4 ▽ THESE DIMENSIONS ASSUME 80% CRUSHING OF THE TRUSSOID HONEYCOMB MATERIAL, BUT DYNAMIC TEST RESULTS INDICATE THAT 90% CRUSHING CAN BE OBTAINED. THE LOWER FIGURE IS USED TO MAKE ALLOWANCE FOR THE CRUSHING OF THE SECONDARY PEDESTAL STRUCTURE.
- 4 ▽ IT IS ASSUMED THAT THE UNSUPPORTED FLOOR PANELS WILL DEFLECT SOMEWHAT AS SHOWN THIS PERMITTING A REALISTIC SEAT MOVEMENT.
- 4 ▽ SEAT POSITION PRIOR TO VERTICAL CRASH LOAD
- 4 ▽ PROBABLE POSITION OF SEAT AFTER 30 G'S HAS BEEN CONTINUOUSLY APPLIED.
- 4 ▽ SYSTEM C.G. MOVEMENT.

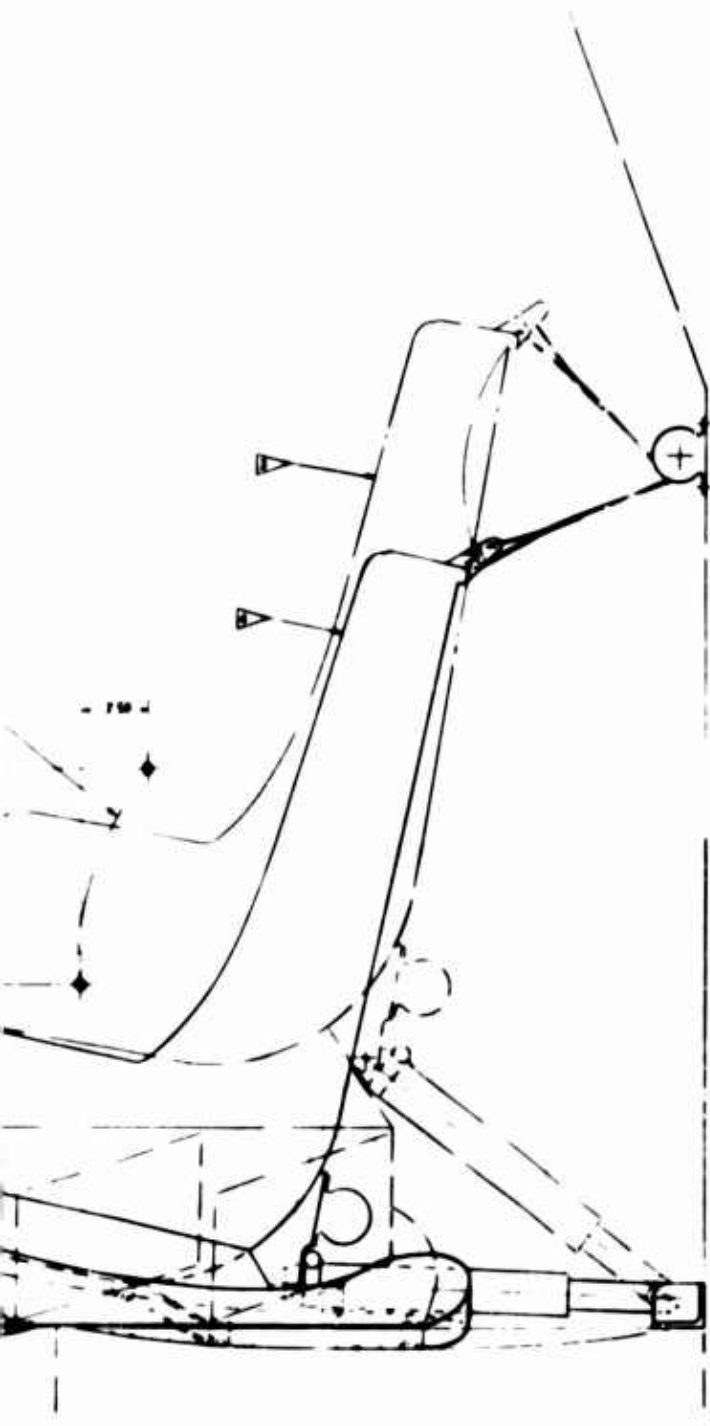

SEAT POSITION PRIOR TO VERTICAL CRASH LOAD

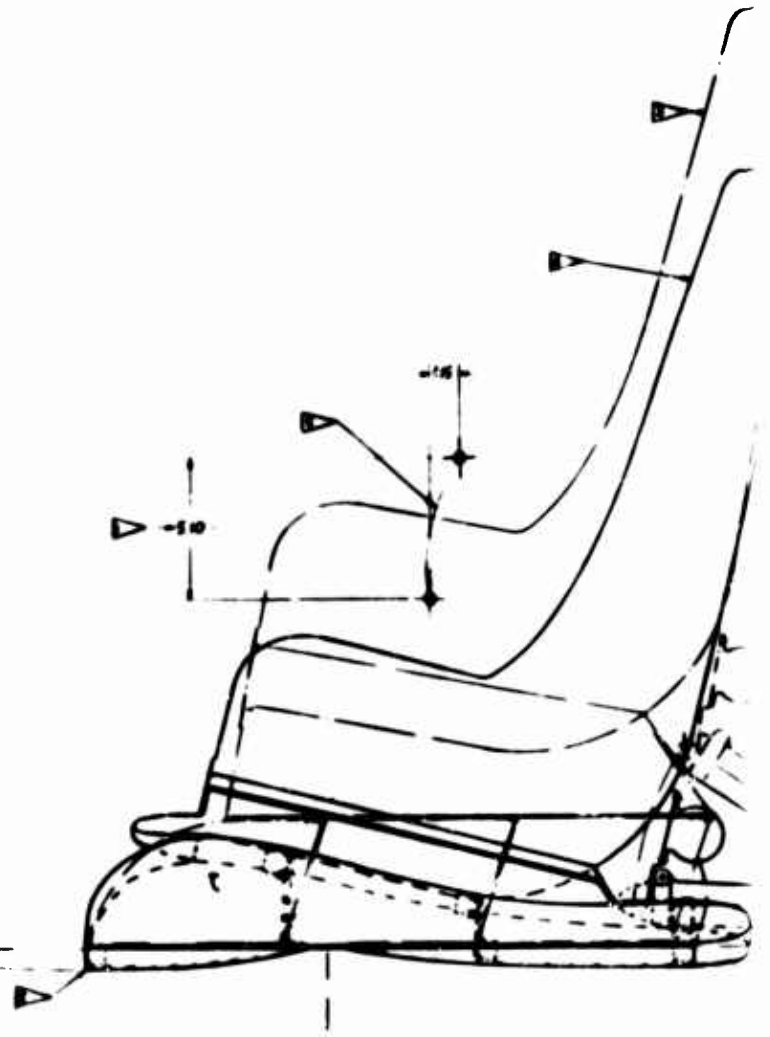

SEAT ADJUSTED FOR 95% TILE MAN AT 199 S LBS.

**PRIN
ONE
INDIC**

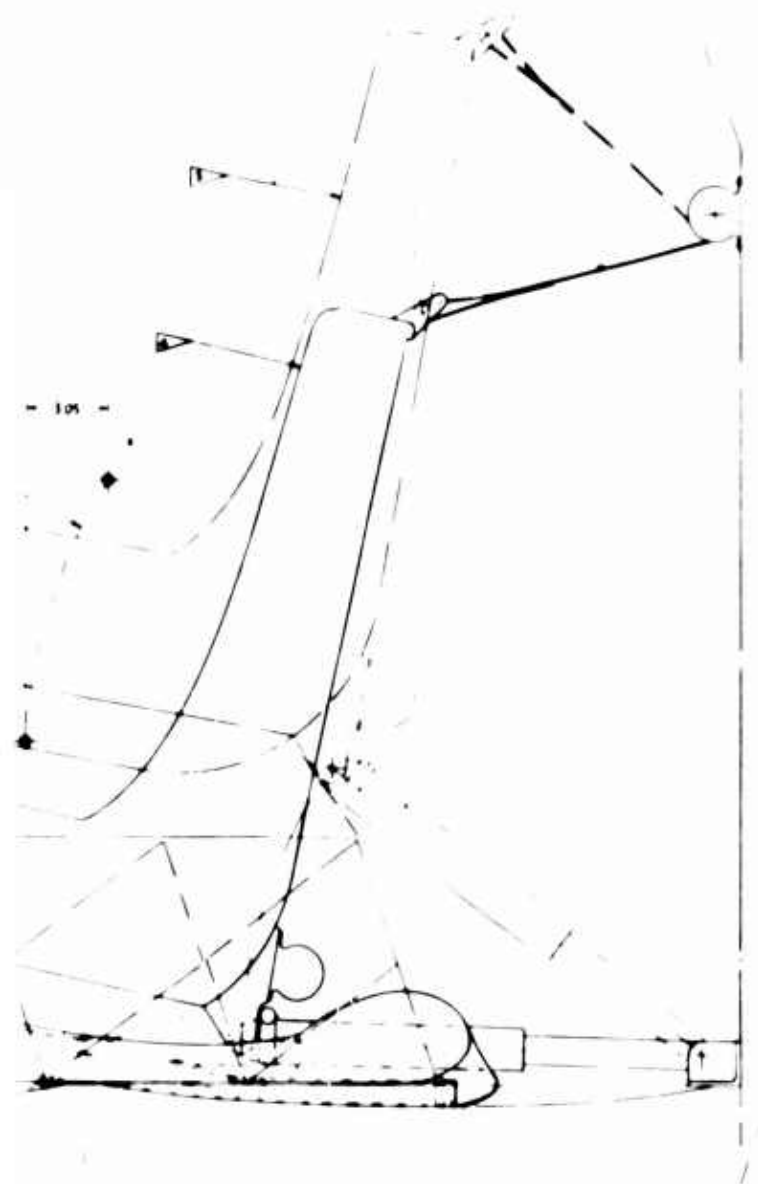

SEAT ADJUSTED FOR 5% TILE MAN AT 135 LBS

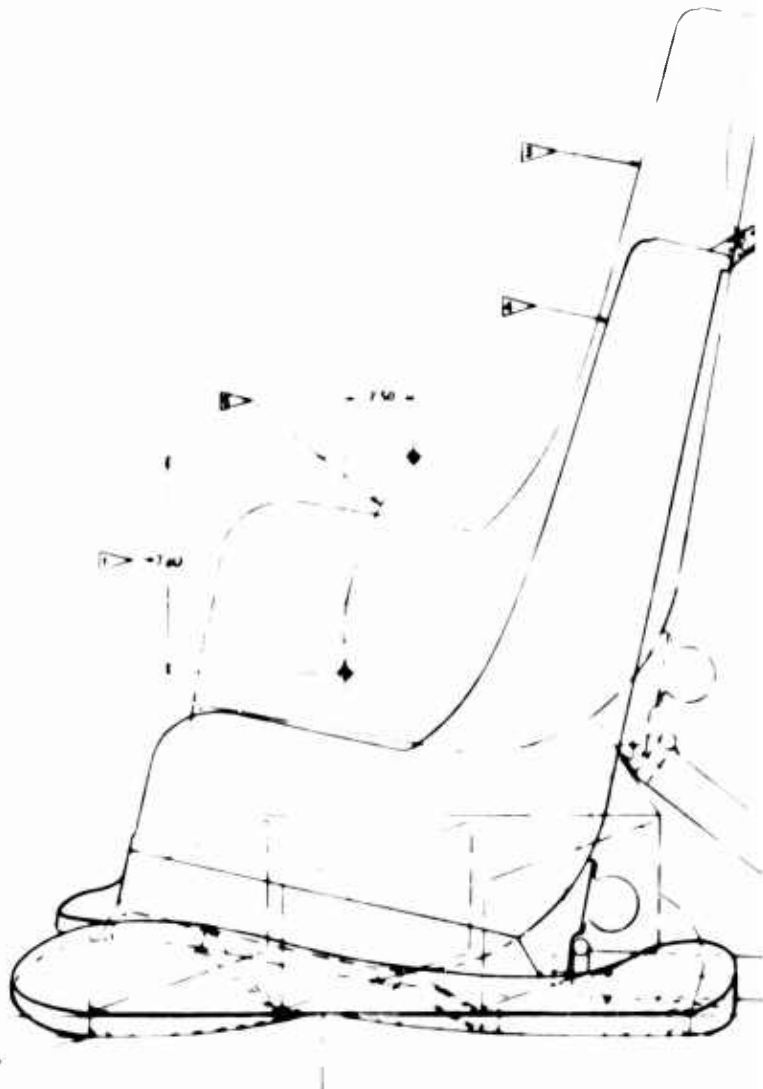

SEAT ADJUSTED FOR 50% TILE MAN AT 166.5 LBS

8

FIGURE 11 LOAD LIMITING BEHAVIOR
35

EXPLANATORY DESIGN NOTES

- 4 ▷ THESE DIMENSIONS ASSUME 80% CRUSHING OF THE TRUSSGRID HONEYCOMB MATERIAL, BUT DYNAMIC TEST RESULTS INDICATE THAT 90% CRUSHING CAN BE OBTAINED THE LOWER FIGURE IS USED TO MAKE ALLOWANCE FOR THE CRUSHING OF THE SECONDARY PEDESTAL STRUCTURE
- 4 ▷ IT IS ASSUMED THAT THE UNSUPPORTED FLOOR PANELS WILL DEFLECT SOMEWHAT AS SHOWN THUS PERMITTING A REALISTIC SEAT MOVEMENT
- 4 ▷ SEAT POSITION PRIOR TO VERTICAL CRASH LOAD
- 4 ▷ PROBABLE POSITION OF SEAT AFTER 20G : 5G HAS BEEN CONTINUOUSLY APPLIED
- 4 ▷ SYSTEM C.G. MOVEMENT

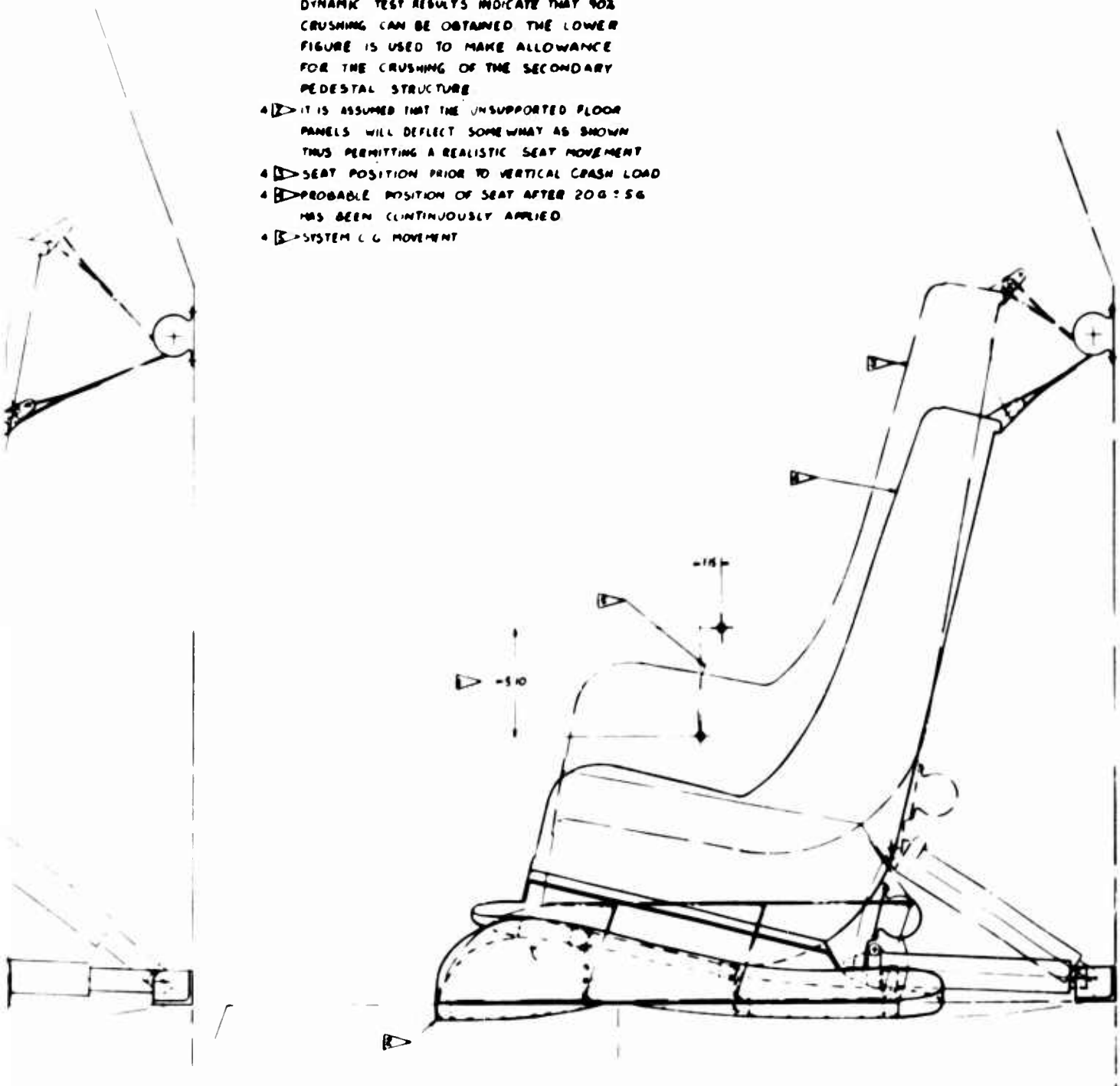

SEAT ADJUSTED FOR 95% TYLE MAN AT 199.5 LBS

**PRINT REDUCED
ONE-QUARTER
INDICATED SCALE**

<p>REVISIONS</p> <table border="1"> <tr> <th>NO.</th> <th>DESCRIPTION</th> <th>DATE</th> </tr> <tr> <td> </td> <td> </td> <td> </td> </tr> </table>		NO.	DESCRIPTION	DATE				<p>LAYOUT OF ARMORED CRASH ATTENUATED PILOT & CO-PILOT SEAT FOR OH-47A HELICOPTER</p>	<p>FIG. 277</p>
NO.	DESCRIPTION	DATE							

OR

LOAD LIMIT VS. STROKE REQUIRED SEAT VERTICAL ENERGY

**H-21A • $V_v = 40$ FT/SEC, $V_h = 48$ FT/SEC, $V_{LAT} = 0.0$ FT/SEC
ACCELEROMETER LOCATED AT
STA. 259.5 ON PASSENGER CABIN FLOOR**

**H-25 • $V_v = 44$ FT/SEC, $V_h = 44$ FT/SEC, $V_{LAT} = 0.0$ FT/SEC
ACCELEROMETER LOCATED ON
PASSENGER CABIN FLOOR**

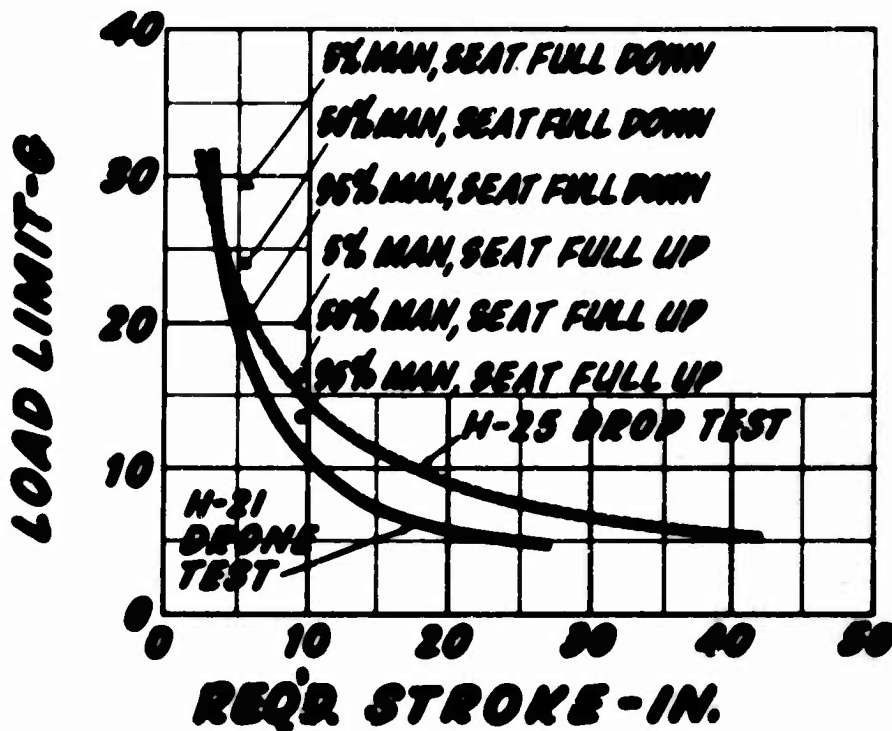

FIGURE 12. LOAD - STROKE CURVE

to rest without bottoming against the floor. The load levels shown represent the mean effective load during crushing of the seat chassis. The deep cockpit belly structure of the CH-47 would probably shift the "stroke required" curve to the left, showing a more favorable seat performance for a 40 ft/sec. sink-rate crash.

The adjustment provided by the subject seat system is a compromise with that called for in Reference 2A. This system gives 40 percent more fore and aft adjustment and 16 percent less vertical adjustment than specified. The adjustment path is an arc struck from a 9.5-inch radius.

The armored seat panel of the seat bucket assembly is face bonded to a pedestal which consists of a solid block of Trussgrid honeycomb material. This block has glass cloth epoxy facings to which the hinges of the diagonal blocks are attached. The lower hinges of the diagonal blocks are attached to a base plate. The hinges and the base plate are bolted to the floor structure at approximately 3½-inch intervals. This arrangement adequately disperses the tie-down loads into the structure.

The introduction of an automatic seat-mounted inertia reel and strap at the top of the seat back was adopted to restrain the seat and occupant in forward and side crash accelerations. The strap end was attached to the bulkhead behind the seat center line. It approximated a parallel link system with the seat adjustment screw jack to keep the seat in the upright position during all specified crash accelerations, as shown in Figure 13.

CRASH WORTHINESS CRITERIA

The design goal was for vertical (headward) loads to be attenuated to $20\text{ g} \pm 5\text{ g}$ continuously maintained in the pelvic region through crushable blocks and through a crushable pedestal attached directly to the seat-pan armor.

BLANK PAGE

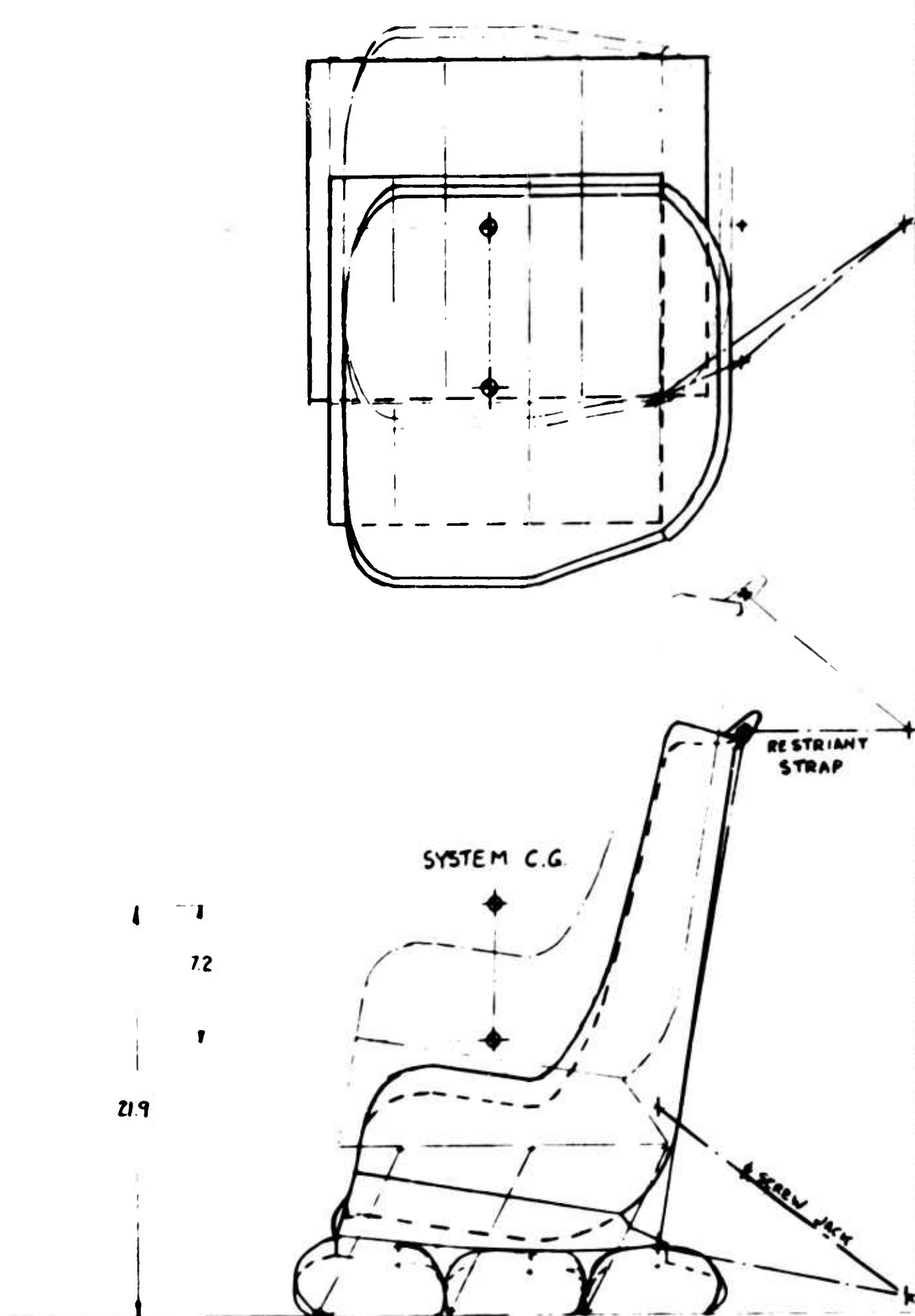
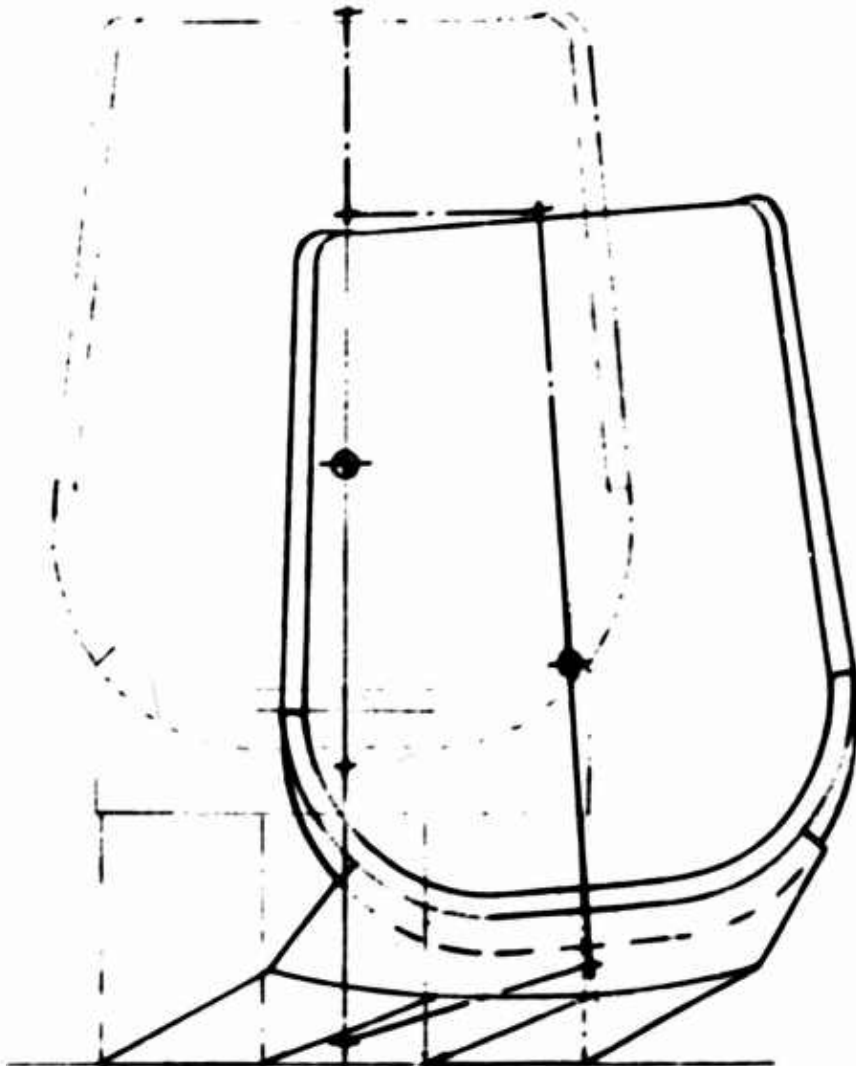

FIGURE 13 SIDE CRASH DIAGRAM

← 8.5 →



**PRINT REDUCED
ONE HALF
INDICATED SCALE**

**PROBABLE LATERAL CRASH
KINEMATICS OF SEAT IN
THE HIGH POSITION WITH
THE 5% TILT 135.9 LBS MAN
BEFORE AND AFTER 45G FOR
.10 SECOND.**

DESIGNER []		DATE []		SCALE 1/2" = 1"		PROJECT []		REV. []			
UNLESS OTHERWISE SPECIFIED DIMENSIONS ARE IN INCHES DECIMALS ON ANGLES				HEAT TREAT Q&L Q&L Q&L Q&L Q&L Q&L Q&L Q&L Q&L Q&L Q&L Q&L Q&L Q&L Q&L Q&L Q&L Q&L				LAYOUT OF ARMORED CRASH ATTENUATED PILOT & CO-PILOT SEAT FOR CH-47A HELICOPTER			
DATE []		BY []		CHKD BY []		APP'D BY []		NO. 77875			
REV. []		DATE []		BY []		CHKD BY []		NO. 6 of 6			

BLANK PAGE

The adjustable blocks are arranged to vary the load limiting action to adjust to man weights from 135.9 pounds to 199.7 pounds. This is automatically obtained when the occupant adjusts the seat for his optimum height and reach. This system assumes that the 5th percentile man at 135.9 pounds will adjust his seat to the highest position, and that the 95th percentile man at 199.7 pounds will adjust to the lowest position. Also, it assumes that those men who fall between this range will have a height and weight proportional to their percentile. This system does not make allowance for the extremes such as a 5 percentile height man weighing 199.7 pounds or a 95th percentile height man weighing 135.9 pounds. Therefore, the seat occupant must consider his weight when making a seat adjustment to obtain optimum vertical crash protection. Since this may not always be done, a non-optimum load limit may sometimes occur.

The longitudinal and lateral design loads of 25 g for 0.20 second and 45 g for 0.10 second are accommodated by allowing the crushable seat pedestal and adjustable blocks to deform. This allows the restraining members to act in tension. In a forward crash, restraint is accomplished by distributing the loads in three locations:

1. At the seat top-center, by a strap which is attached to the bulkhead behind the seat. The strap acts through an inertia-sensitive reel on the back of the seat.
2. At the back of the seat, at the intersection of the bucket and pan by tension on the adjustable screw jack. The jack is attached to the seat base at the floor bulkhead intersectio.
3. At the adjustable blocks, by partial crushing of the combined pedestal and support structure. This provides some attenuation at the load onset, and it provides position retention thereafter.

The side load retention assumes that a considerable deformation of the combined crushable base will take place before the main restraint members (strap and screw jack) take up the load. This is shown in Figure 13. The amount of travel to either side will vary from 5 to 8 inches, depending on the initial seat adjustment.

FIELD REPLACEMENT OF ARMORED PANELS

Replacement of the left- and right-hand armor panels and the back panel can be made by removing the cushions and removing the screws which attach the panels to the frame. It is intended that the production armored panels and frames will be made interchangeable by close tolerance control of all the mating parts.

Replacement of the seat-pan armored panel is considered impractical due to (1) integration with the seat pedestal required by the high crash criteria, and (2) ballistic damage to the seat-pan panel can occur only when a round has passed through the seat base. This will probably cause sufficient damage to impair the seat adjustment function and crash protection. Therefore, damage to the seat base would require complete replacement of the seat. Complete replacement of the torso protector and shoulder armor is recommended after ballistic damage. Undamaged hardware can be retained for subsequent reassembly in new units.

REFERENCES

1. Anthropometry of Army Aviators, Natick Q.R.E.C. Technical Report, EP-150.
2. Crew Seat Design Criteria for Army Aircraft, TRECOM Technical Report 63-4, February 1963.
3. Energy Absorbing Characteristics Trussgrid and Spiralgrid, General Grid Corporation, Edgewood Arsenal, Maryland.
4. The Boeing Company, Wichita, Kansas, Human Engineering Design Data, Glen W. Allen, 1962, September, D3-4700.
5. Lunar Landing Problems, General Grid Corporation, Edgewood Arsenal, Maryland.
6. Personnel Restraint Systems Study HC-1B Vertol Chinook, Aviation Crash Injury Research, Phoenix, Arizona, AVCIR 62-26, November 1962.
7. Swearingen, John J., E. B. McFadden, J. D. Garner and J. G. Blethrow, Human Voluntary Tolerance to Vertical Impact, Aerospace Medicine, December 1960.
8. Personnel Restraint Systems Study, Basic Concepts, TCREC Technical Report 62-94, U. S. Army Transportation Research Command, Fort Eustis, Virginia, December 1964.

9. Preliminary Information on Results of U. S. Army/FSF Helicopter Crash Test Number 7, conducted at Deer Valley Airport, Phoenix, Arizona, Flight Safety Foundation, Inc., September 1962.
10. Trussgrid Landing Test Results, General Grid Corporation, Army Chemical Center, Maryland.
11. Seats, Pilots, Adjustable, Short Range Aircraft, MIL-S-7832A.
12. Seat, Pilot's Adjustable, Short Range Aircraft, MIL-S-5822.
13. Reels Shoulder Harness Takeup, Inertia Lock, MIL-R-8236B.
14. Dimensions, Basic, Cockpit Helicopter, MS 33575.

DISTRIBUTION

US Army Materiel Command	4
US Army Mobility Command	2
US Army Aviation Materiel Command	5
Chief of R&D, D/A	2
US Army Transportation Research Command	33
USATRECOM Liaison Officer, US Army R&D Group (Europe)	1
US Army Natick Laboratories	1
US Army Engineer R&D Laboratories	2
US Army Signal R&D Laboratory Liaison Office, USACDC	1
US Army Limited War Laboratory	1
US Army Human Engineering Laboratories	1
Army Research Office-Du-ham	2
US Army Test and Evaluation Command	1
US Army Research Support Group	1
US Army Medical Research Laboratory	1
US Army Combat Developments Command Aviation Agency	1
US Army Combat Developments Command Armor Agency	1
US Army Combat Developments Command Transportation Agency	1
US Army War College	1
US Army Command and General Staff College	1
US Army Transportation School	3
US Army Aviation School	1
US Army Armor Board	1
US Army Aviation Test Board	1
TC Liaison Officer, US Army Airborne, Electronics and Special Warfare Board	1
US Army Aviation Test Activity	1
Air Force Systems Command, Wright-Patterson AFB	2
US Naval Air Station, Patuxent River	1
US Naval Ordnance Test Station	1
Marine Corps Landing Force Development Center	1
Marine Corps Liaison Officer, US Army Transportation School	1
Ames Research Center, NASA	1
NASA-LRC, Langley Station	1
NASA Representative, Scientific and Technical Information Facility	2
US Army Standardization Group, Canada	1
Canadian Liaison Officer, US Army Transportation School	1
British Army Staff, British Embassy, Washington	1
US Army Standardization Group, U. K.	1
Defense Documentation Center	20

BLANK PAGE

APPENDIX I

SUGGESTED STRUCTURAL CHANGES REQUIRED TO FIT ARMORED PILOT/COPILOT SEAT INTO THE CH-47A COCKPIT

DESCRIPTION OF RETENTION REQUIRED

The seat base (SK13558) is bolted directly to the floor and bulkhead at Sta. 95 by 36 $\frac{1}{4}$ -inch diameter bolts; 16 of these bolts attach the toggle block piano hinges to the floor. The upper restraint strap is attached to Sta. 95 on the seat centerline (BL 22.0 pilot and BL 23.0 copilot) with 4 $\frac{1}{4}$ -inch diameter bolts.

SUGGESTED STRUCTURAL CHANGES

Efforts have been made in this seat design to pick up a maximum of existing structure. The middle and rear crushable block hinges and the seat base frame will pick up on existing structural locations. The forward crushable block hinges will, however, require additional structural support. These forward hinges will take approximately 33% of the vertical crash loads and about 60% of the maneuver loads.

1. Forward Hinge Support (Sta. 59.5 Approx.)

Redesign the control support assembly 114C1102 and 1103, leaving all bellcranks and bearings in their present locations to allow the seat support beams 114S1108 to be extended forward of the frame at Sta. 70.62 (114S1402) to approx. Sta. 59.5. Add two box beams at approx. 3.0 inches on either side of the pitch roll control centerline and close with a transverse beam at Sta. 59.5 to coincide with and include the forward pitch roll control bearing. Add the bolt pattern shown on SK13558, using floating anchor nuts in place of the present panel

fasteners. It is thought that the present concept of a removable control assembly can still be retained by making it "Tee" shaped. Some compromise may be necessary with the collective pitch thrust control mount. The removable floor panel would have to be reduced to span between Sta. 59.5 and Sta. 51.75.

2. Middle Hinge Support (Sta. 70.62)

This hinge is designed to pick up on frame Sta. 70.62 (114S1402); substitute floating anchor nuts to suit SK13558 for the present panel fasteners.

3. Rear Hinge Support (Sta. 77.35)

Add a beam between the seat support beams 114S1108 at approx. Sta. 77.35; add floating anchor nuts to suit SK13558.

4. Seat Support Beams (BL 11.93 & 32.07 Pilot and BL 10.93 & 31.07 Copilot)

Redesign the seat support beams 114S1108 to suit SK13558 by replacing existing fasteners with floating anchor nuts. Add diagonal support members to suit the last eight bolt holes on the seat base SK13558 between the seat support beam and the lower frame 114S1403 floor support angle at Sta. 95.0.

5. Reinforcement at WL 10.0 & Sta. 95.0 on Seat Centerlines

This reinforcement could take the form of a "Tee" extrusion on the back face of the bulkhead and an angle extrusion under the floor support angle. The width and taper of these members are to be determined by the best load dispersal path into the adjacent structure.

6. Reinforcement of Bulkhead at Sta. 95 at WL 16.1 on Seat Centerlines

This could take the form of a local spreader plate backed up by a vertical channel placed between the structure at WL 17 and WL 13.

REFERENCE DRAWINGS USED IN THIS STUDY

114C1100	Controls Cockpit	114S1101	Frame Sta. 95.00
114C1102	Support Assy. Pilot	114S1108	Beam Seat Support
114C1103	Support Assy. Co-pilot	114S1401	Canted Beam Sta. 51.75
		114S1402	Frame Sta. 70.62
		114S1403	Lower Frame Sta. 95.00
		114S1551	Cockpit Floor

APPENDIX II

ESTIMATED WEIGHT BREAKDOWN PER SEAT

Armor

Seat Bucket	7.41 ft ²	@ 10 lb/ft ²	=	74.10	
Torso Panel	2.3 ft ²	@ 10 lb/ft ²	=	23.00	
Shoulder Panel	1.2 ft ²	@ 10 lb/ft ²	=	12.00	
					Total
					109.10

Seat Chassis

Base	=	5.83	
Adjustment Blocks	=	11.50	
Pedestal	=	8.00	
Frame	=	5.26	
Screw Jack	=	3.30	
Torso Protector Support and Harness Lock	=	2.75	
			Total
			36.64

Standard Hardware

Lap Belt	=	5.68	
Inertia Reel (Harness)	=	1.75	
Inertia Reel (Seat Frame)	=	1.75	
Hand Crank	=	.70	
Flexible Drive	=	.40	
Inertia Release Handle	=	1.50	
Shoulder Harness	=	1.18	
			Total
			12.96

Assembled Seat Total		<u>158.70</u>
System Weight		317.40

APPENDIX III

LIST OF APPROVED ENGINEERING DRAWINGS USED FOR
THE MANUFACTURE OF SEAT HARDWARE

<u>Drawing Number</u>	<u>Title</u>
SK13025	Inboard Profile Pilot/Copilot Armored Crash Seats
SK13026	Seat Cushions
SK13027	Assembly of Pilot/Copilot Seat
SK13028	Armored Seat Bucket Assembly
SK13029 (1 & 2)	Seat Details
SK13030	Seat Frame
*SK13031	Pedestal Assembly
*SK13032 (1 & 2)	Adjustment Block Details
SK13033	S.C.D. Adjustment Screw Jack
SK13034	Side Panel Assembly
SK13035	Armored Torso Protector Assembly
*SK13036	Seat Base Assembly
SK13037	S.C.D. Torso Protector Support and Harness Lock
SK13038	Shoulder Harness Assembly
SK13148	Armored Panels, Side and Torso Protector

*The following drawings were used in place of those indicated to
simplify manufacture:

SK13039	Pedestal Assembly
SK13040	Seat Adjustment Blocks
SK13558	Seat Base

APPENDIX IV

LOADS AND STRESS REPORT

This report is a kinematic, loads and stress analysis of the Armor Protection Pilot/Copilot Seat for the CH-47A Helicopter With Crash-Safety Features.

1 SIGN CONVENTION

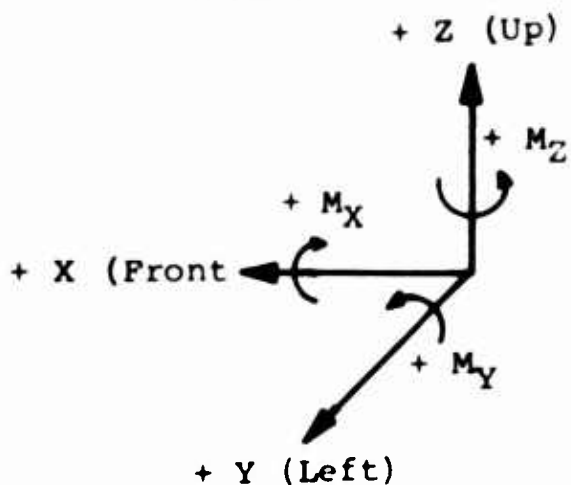

2 DESIGN CRITERIA

Design Loads

- 2.1 Limit load: $\pm 5g$, vertical maneuver, static load
- 2.2 Ultimate load with attenuation: 25g downward
- 2.3 Ultimate load without attenuation: 45g forward, backward and sideward
- 2.4 The calculations must be done separately for the 5th percentile man and 95th percentile man, in order to determine the worst possible combination of loads.

3 **WEIGHTS**

- 3.1 5th percentile man, 136 pounds (stripped).
- 3.2 50th percentile man, 166.5 pounds (stripped).
- 3.3 95th percentile man, 200 pounds (stripped).
- 3.4 In accordance with information received from USATRECCM Contracting Officer's Representative, R. Fama, the total weight of battle gear, including normal clothing, flight suit, gloves, helmet, goggles, pistol-holster-ammunition, but no parachute nor survival kit - 5th percentile man, 15 pounds; 95th percentile man, 20 pounds.
- 3.5 Total weight, 5th percentile man, 151 pounds.
- 3.6 Total weight, 50th percentile man, 184 pounds.
- 3.7 Total weight, 95th percentile man, 220 pounds.
- 3.8 The application of total weight of the pilot (copilot) to the structure of the seat is assumed to be at the navel point of a sitting person.



FIGURE 14

- 3.9 For calculating maneuver loads, a reduced total weight is assumed due to the distribution of part of the weight (legs and boots) on the controls.

- 3.10 Reduced total weight, 5th percentile man, 130 pounds.
- 3.11 Reduced total weight, 95th percentile man, 200 pounds.
- 3.12 To calculate attenuation (dynamic) loads the same reduced weight is applicable, since the legs and feet react directly against the floor.



FIGURE 15

- 3.13 The weight of the seat (movable part) is 83 pounds
 To this must be added 75% of the weight of the 3.3-pound screw jack. 2.5 pounds
 The weight of the restraint straps is 2.5 pounds
 The total seat weight is 88 pounds

- 3.14 The weight of the frontal armor plate is 26 pounds.

4 LOAD DISTRIBUTION

- 4.1 The weight of the pilot has a high degree of distribution; moreover, the chair itself. The frontal armor plate acts in a vertical g case as a pointed load; however, due to the Truss-grid blocks, the weight of the frontal armor is also a distributed load because of the high rigidity of the chair.
- 4.2 Therefore, the use of the involved weights as vectors is proper only if the structure of the chair is regarded as a rigid body.

5 GEOMETRY

- 5.1 Figure 16 indicates all dimensional data necessary for stress calculations pertaining to the geometry of the seat. In addition, the positions of the centers-of-gravity of the pilot, seat, and frontal armor plate are shown. The middle position of adjustment of the seat is illustrated, corresponding to that for a 50th percentile man.
- 5.2 The dimensions of every point of the seat in the up position (corresponding to that for a 5th percentile man) may be obtained through the following translation formulas:

$$X_{up} = X_{middle} + 2.00 \text{ inches.}$$

$$Y_{up} = Y_{middle}$$

$$Z_{up} = Z_{middle} + 1.50 \text{ inches.}$$

- 5.3 The dimensions of every point of the seat in the down position (corresponding to that for a 95th percentile man) may be obtained through the following translation formulas:

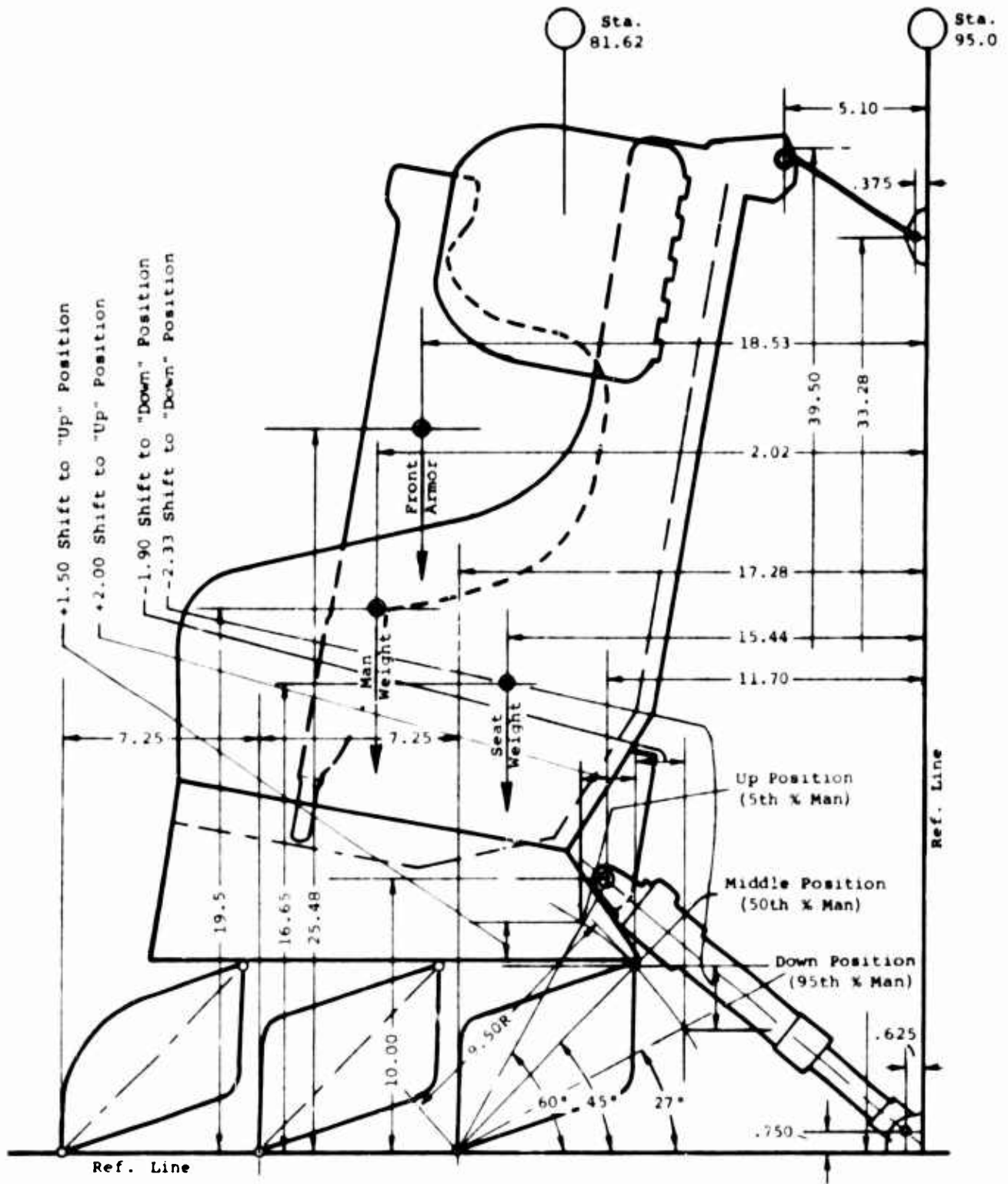

FIGURE 16

$$X_{\text{down}} = X_{\text{middle}} - 1.90 \text{ inches.}$$

$$Y_{\text{down}} = Y_{\text{middle}}$$

$$Z_{\text{down}} = Z_{\text{middle}} - 2.33 \text{ inches.}$$

6 MOVEMENTS OF THE SEAT

6.1 Movement of the Seat, Due to Seat Adjustment -

Being rigidly fastened to the floor, the seat together with the Trussgrid blocks form a parallelogram. Thus motion of the seat in plane X, Z could be only parallel to the original seat position. This motion occurs when the pilot actuates the adjusting screw.

The restraint straps do not produce any appreciable force on the seat, since reel release is at small acceleration.

6.2 Movement of the Seat at Maneuver g Loads -

During flight, the seat, supporting the pilot, has quite a different motion at g load down, due to the fact that the flexibility of the screw jack and Trussgrid blocks are not comparable. It will be proper to disregard any change in the length of the adjusting screw jack and to thus regard it as completely rigid. On the other hand, the restraint straps do not produce any appreciable load, since the g load could build itself up slowly enough to permit a strap release. Due to these conditions, the chair will only move along the arc described by the motion of the screw jack and will rotate only about the juncture of the screw jack and seat.

6.3 At a sudden change in g loading (crash impact) forward or down, the inertial reel will operate, locking the straps and thus limiting the motion of the chair to the motion of a member of a parallelogram (see Figure 17). Due to the fact

that the restraining straps and adjusting screw jack are parallel, the motion of the chair body



FIGURE 17

may be regarded as parallel to its original position, within small deflection. Thus, initial crushing loads on the Trussgrid blocks may be regarded as equal to one another, since the Trussgrid blocks are identical and are similarly situated. With any further downward motion, the chair is not moving parallel to its original position, due to a difference in the lengths of the restraint straps and adjusting screw jack; but the Trussgrid blocks are fully engaged and the difference in their loading is irrelevant.

7 MANEUVER G LOADS

7.1 The 5th Percentile Man -

Man's weight (see Section 3.10) is 130 pounds, W_m .
Seat weight (see Section 3.13) is 88 pounds, W_s .
Frontal armor plate weight (see Section 3.14) is 26 pounds, W_p .

7.2 Assumptions -

- a. The base and seat are regarded as a rigid body.
- b. Trussgrid blocks act as a strut (until crushing force is applied).

- c. The force in the restraint straps is $T_{rs} = 0$.
- d. The screw jack is regarded as a perfectly rigid body.
- e. The seat is in the up position.

7.3 The Loads at 5g (Up) -

$$W_m = 130 \times 5 = 650 \text{ pounds}$$

$$W_s = 88 \times 5 = 440 \text{ pounds}$$

$$W_p = 26 \times 5 = 130 \text{ pounds}$$

7.4 Resulting Force -

$$R = W_m + W_s + W_p = 1220 \text{ pounds.}$$

7.5 The Location of the Resulting Force -

$$650(20.2 + 2.00) + 440(15.44 + 2.00) + 130(18.53 + 2.00) = R_x$$

$$X = \frac{14420 + 7670 + 2760}{1220} = 20.26$$

and

$$650(19.5 + 1.50) + 440(16.65 + 1.50) + 130(25.48 + 1.5) = R_z$$

and

$$Z = \frac{13650 + 7550 + 3500}{1220} = 20.22$$

- 7.6 The system is statically indeterminate. The body of the seat acts as a rigid body; thus, the translations of each point of the body are

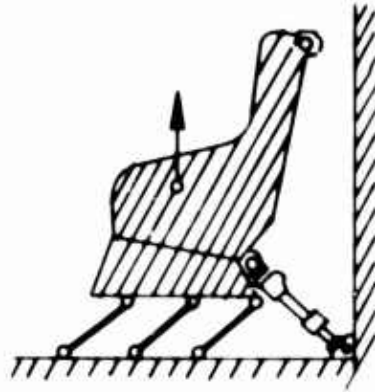

FIGURE 18

interdependent. This will be used to solve the problem for reactions.

- 7.7 The actual scheme may be exchanged through the intermediate scheme as follows (see Figure 20).

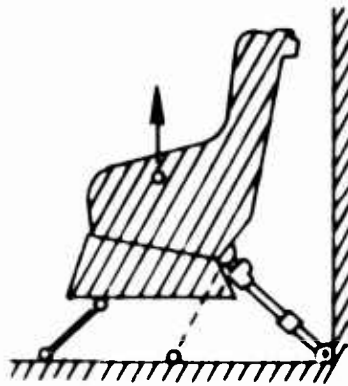

FIGURE 19

7.8 Calculations -

Taking the sum of forces on X and Z,

$$\Sigma Z; +1220 + R_1 \cos 30^\circ + Z = 0$$

$$\Sigma X; -R_1 \sin 30^\circ + X = 0$$

$$\Sigma M_4; R_1 10.11 + 1220 \times 6.64 = 0$$

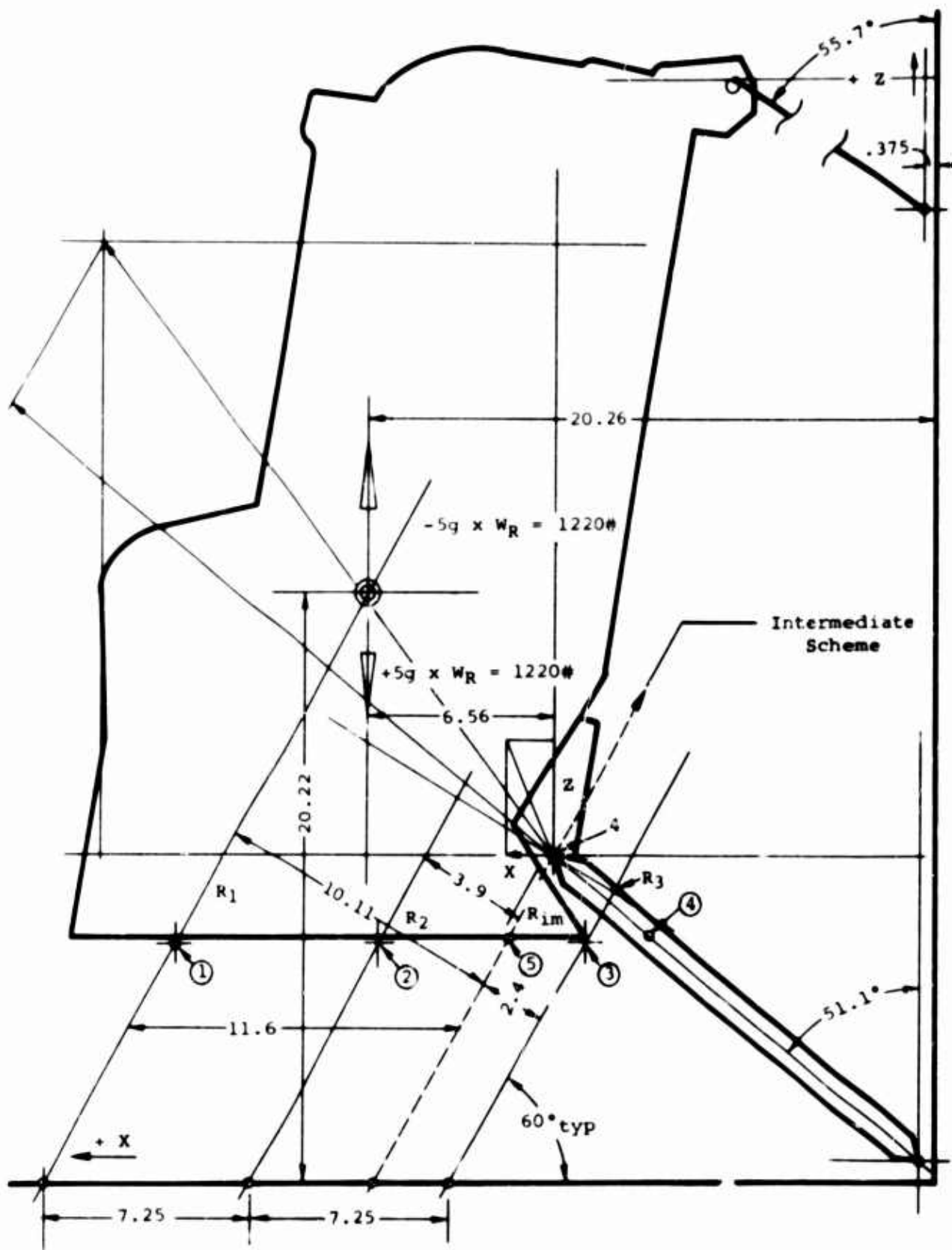

FIGURE 20

and

$$R_1 = -8.00 \text{ pounds.}$$

The minus sign indicates that the direction of force R_1 was selected erroneously. In relation to the seat body, R_1 is directed downward. In strut (1) (Trussgrid block) on Figure 20, this will be tension.

$$\cos 30^\circ = 0.866$$

$$\sin 30^\circ = 0.500$$

and

$$+1220 - 800 \times 0.866 + Z = 0$$

$$Z = -1220 + 692 = -528 \text{ pounds}$$

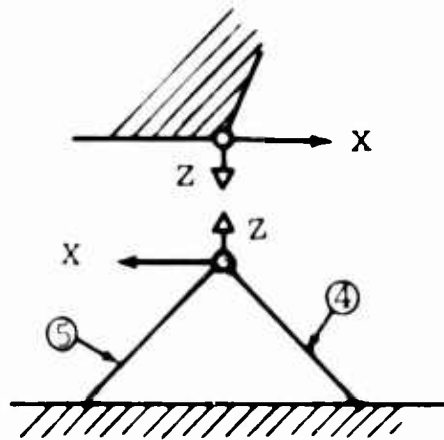

FIGURE 21

and

$$-(-800) 0.5 + X = 0$$

$$X = -400 \text{ pounds}$$

Considering two struts (4) and (5) as a truss, the resultant force may be determined.

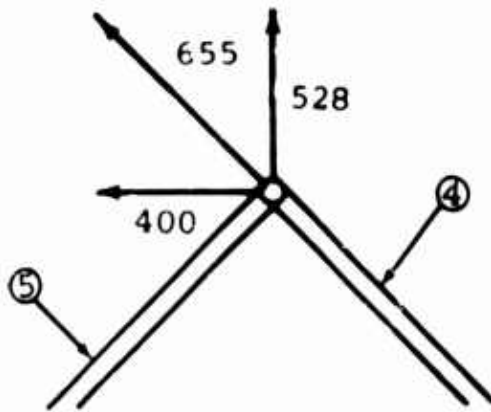

FIGURE 22

Resolving this force on struts ④ and ⑤ , it is determined that:

In strut ④ , it is tension $P_4 = 620$ pounds.

In strut ⑤ , it is tension $P_5 = 163$ pounds.

The struts ① , ② and ③ are identical bodies. The imaginary strut ⑤ is longer (12.8 to 9.5 inches) but accepted to have the same physical properties as the struts ① , ② and ③ . Thus, each strut will elongate, according to the force applied to this strut.

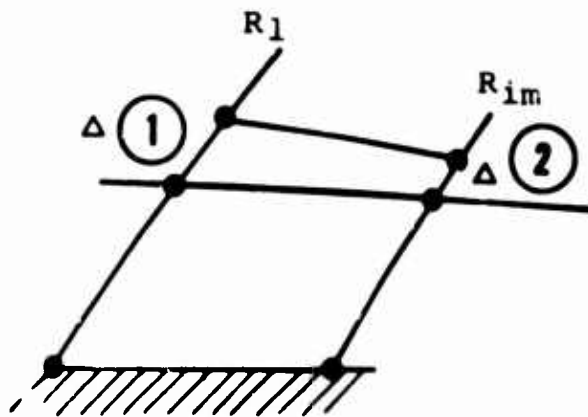

FIGURE 23

Inasmuch as strut (4) (the screw jack) is accepted as perfectly rigid, only the translations of the Trussgrid blocks need be considered. Since strut (4) is nearly perpendicular to struts (1), (2) and (3), the translation of the bottom frame of the seat along the strut line is considered. The body is regarded as rigid, so these translations do determine the motion of the whole body.

Translation at strut (1) is selected as unit translation.

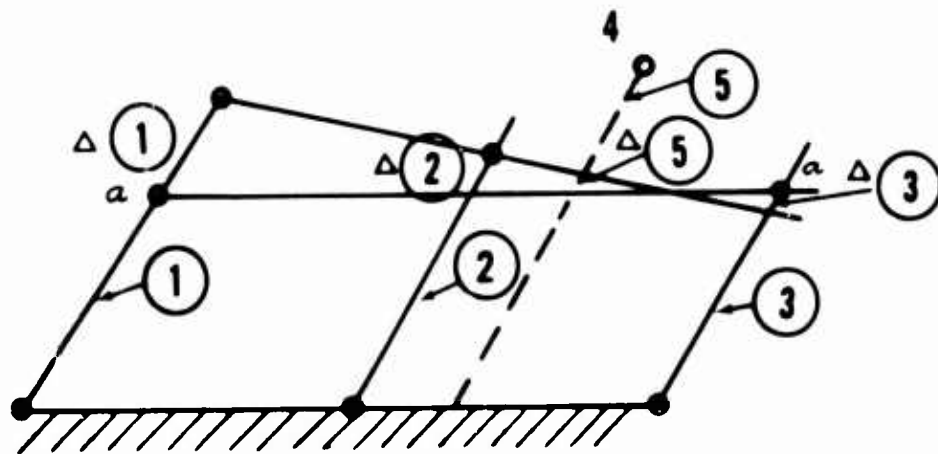

FIGURE 24

Translation of strut (5) at common line a-a is less than that at point (4). The equivalent force (actually, a translation having the numerical value of the force) at the common line is:

$$P_{eq} = \frac{9.5}{12.8} \times 163 = 121 \text{ pounds}$$

thus,

$$\Delta(5) = \frac{121}{163} \Delta(4) = 0.151 \Delta(4)$$

Accepting $\Delta(1)$ as 100 per cent,

$$\Delta(2) = 0.49 \Delta(1)$$

$$\Delta(3) = -0.06 \Delta(1)$$

Now, the imaginary strut ⑤ is exchanged with struts ② and ③ in such a manner that the

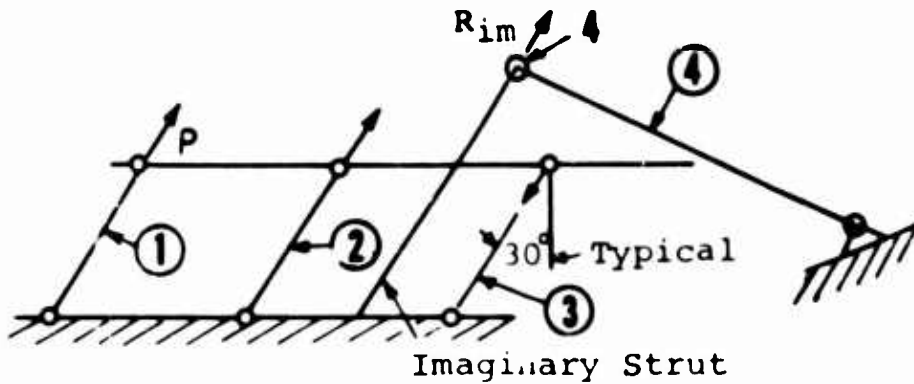

FIGURE 25

sum of all three components of forces P_1 , P_2 and P_3 will be the same as the sum of component $R_1 \cos a + R_{im} \cos a$ thus,

$$\cos a (P_1 + 0.49 P_1 - 0.06 P_1) = \cos a (R_1 + R_{im})$$

and

$$1.43 P_1 = 300 + 163 = 963$$

$$P_1 = \frac{963}{1.43} = 674 \text{ pounds}$$

and

$$P_2 = 0.49 \times 674 = 331 \text{ pounds}$$

$$P_3 = -0.06 \times 674 = -40.5 \text{ pounds}$$

tension forces in struts ① and ②

compression force in strut ③

This method is an approximation. It regards the seat as a rigid body which does not have its own local deflections. The method is more accurate however, than to assume flexibilities in the complicated and very rigid body.

7.9 The Loads -5g (Down), 5th Percentile Man -

The outside forces remain the same in numerical value but are directed downward in this case. Inasmuch as no ordinates along the Z axis were used in calculating forces acting on the Truss-grid blocks, the same procedure is followed and the results are of same numerical value although of different sign. Thus, the total loads (for both sides) in the Trussgrid blocks are:

$$\begin{array}{l} P_1 = -674 \text{ pounds} \\ P_2 = -331 \text{ pounds} \\ P_3 = +40.5 \text{ pounds} \end{array} \left. \vphantom{\begin{array}{l} P_1 \\ P_2 \\ P_3 \end{array}} \right\} \begin{array}{l} \text{compression loads} \\ \text{compression loads} \\ \text{tension loads} \end{array}$$

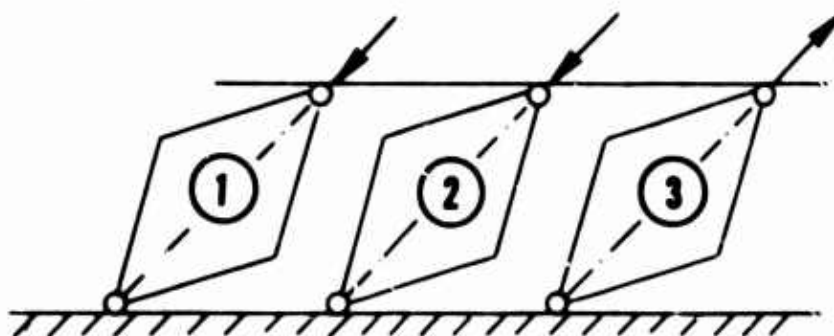

FIGURE 26

7.10 The 95th Percentile Man -

Man's weight (see Section 3.10), 200 pounds, W_m .
Seat weight (see Section 3.13), 88 pounds, W_s .
Frontal armor plate weight (see Section 3.14),
26 pounds, W_p .

7.11 Assumptions - The assumptions of Section 7.2 above remain valid for the case of the 95th percentile man except that assumption (e) changes as follows:

- e. Seat is in down position.

7.12 The Loads + 5g (Up) -

$$W_m = 200 \times 5 = 1000 \text{ pounds}$$

$$W_s = 88 \times 5 = 440 \text{ pounds}$$

$$W_p = 26 \times 5 = 130 \text{ pounds}$$

7.13 Resultant Force -

$$R = W_m + W_s + W_p = 1570 \text{ pounds}$$

7.14 The Location of the Resulting Force (see Figure 16) -

$$1000(20.2 - 1.90) + 440(15.44 - 1.90) +$$

$$130(18.53 - 1.90) = R_x$$

$$x = \frac{18,300 + 5,950 + 2,160}{1,570} = 16.82$$

and

$$1000(19.5 - 2.33) + 440(16.65 - 2.33) +$$

$$130(25.48 - 2.33) = R_z$$

$$z = \frac{17,170 + 6,300 + 3,010}{1,570} = 16.87$$

7.15 The system is statically indeterminate. The same method is employed here as was used in Section 7.6:

FIGURE 27

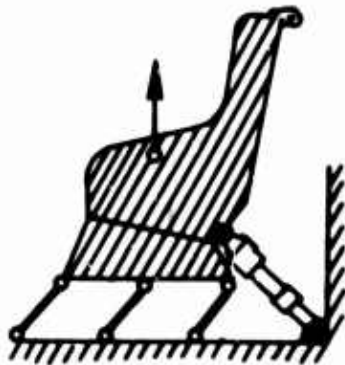

7.16 The actual scheme is readily solved through the intermediate scheme (see Figure 29).

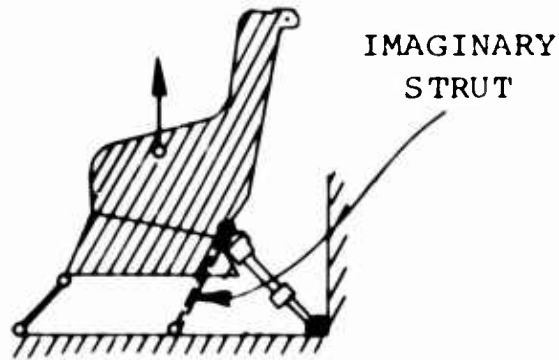

FIGURE 28

7.17 Calculations -
Taking the sum of forces on X and Z

$$a = 90 - 27 = 63^\circ$$

$$\Sigma Z \quad + 1570 + R_1 \cos 63^\circ + Z = 0$$

$$\Sigma X \quad + R_1 \sin 63^\circ + X = 0$$

$$\Sigma M_4 \quad + R_1 \cdot 3.63 + 1570 \times 7.02 = 0$$

and

$$R_1 = -3034 \text{ pounds}$$

The minus sign indicates that the originally selected direction was incorrect. In relation to the seat body, the force R_1 is directed downward. On strut (1) (Trussgrid block), this force is a tension.

$$\cos 63^\circ = 0.4540$$

$$\sin 63^\circ = 0.8910$$

and

$$\Sigma Z \quad + 1570 - 3034 \times 0.4540 + Z = 0$$

$$Z = -1570 + 1376 = 194 \text{ pounds}$$

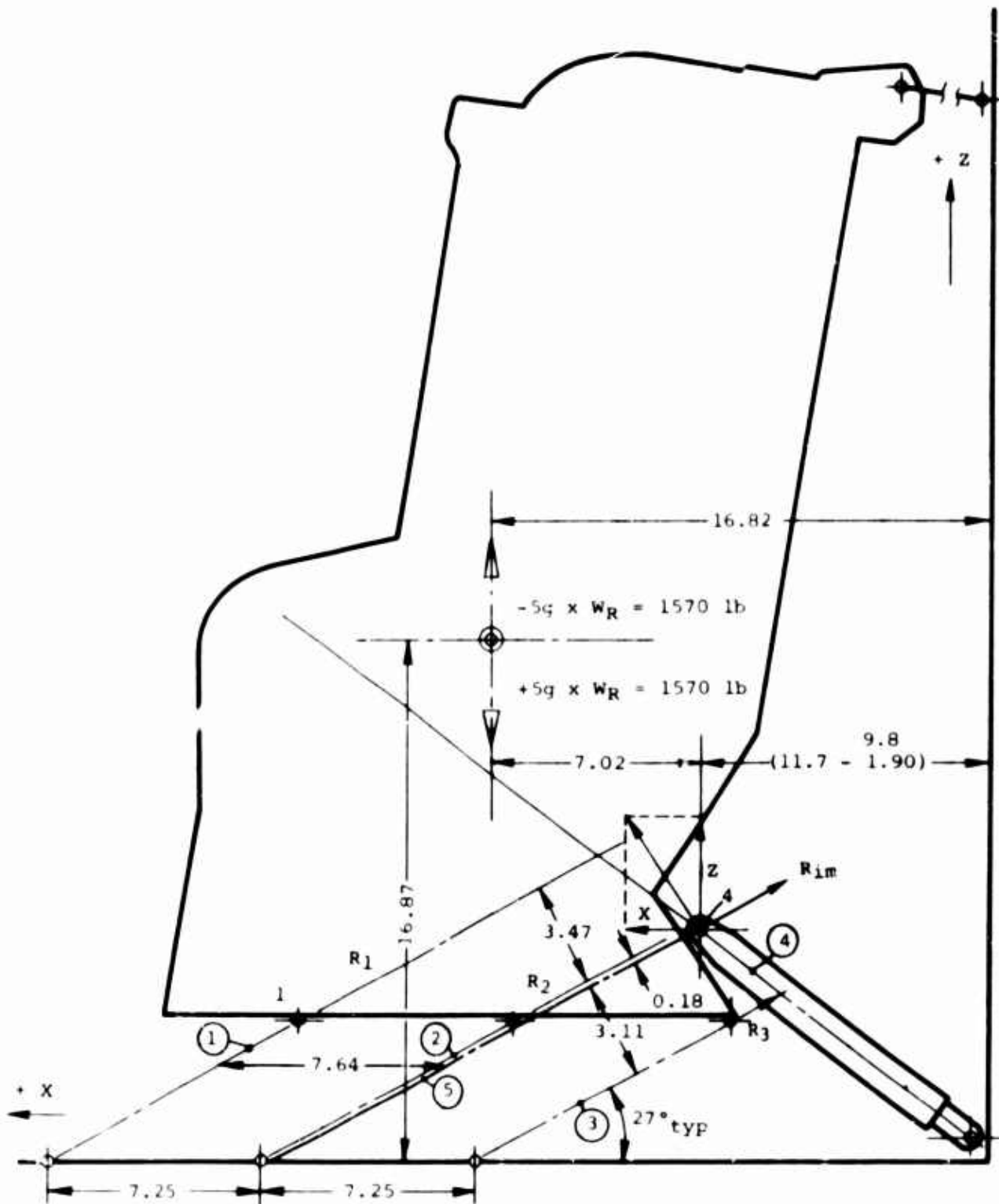

FIGURE 29

In relation to the seat body, the direction of the force Z is incorrectly selected (minus sign). Therefore, it will be directed downward. Then on the Trussgrid blocks ④ and ⑤, it will be

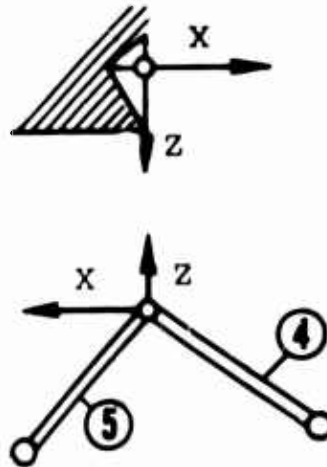

FIGURE 30

directed in the opposite manner.

On the X axis,

$$-(-3034) \cdot 0.8910 + X = 0$$

$$X = -2700 \text{ pounds.}$$

Considering the two struts ④ and ⑤ as a truss, the resultant force may be determined. Resolving this resultant force (2705 pounds) on strut ④ and

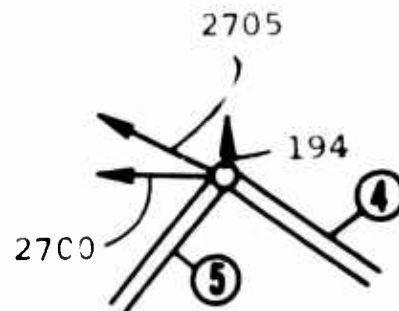

FIGURE 31

⑤, it is found that:

In strut ④, it is tension, $P_4 = 1585$ pounds.

In strut ⑤, it is compression, $P_5 = 1600$ pounds.

The actual motion of the chair body is not as obvious here as it is in case described in Section 7.8; however, since all translations can be assumed to be linear, the body will have a common center of rotation (the body of the chair is rigid). Further, it is known that the translations of points 1, 2 and 3 (upper ends of struts ①, ② and ③) will be in the direction of the struts for small movements such as deflections within the elasticity limit. Thus a chart of the relative motions of points 1, 2 and 3 may be constructed.

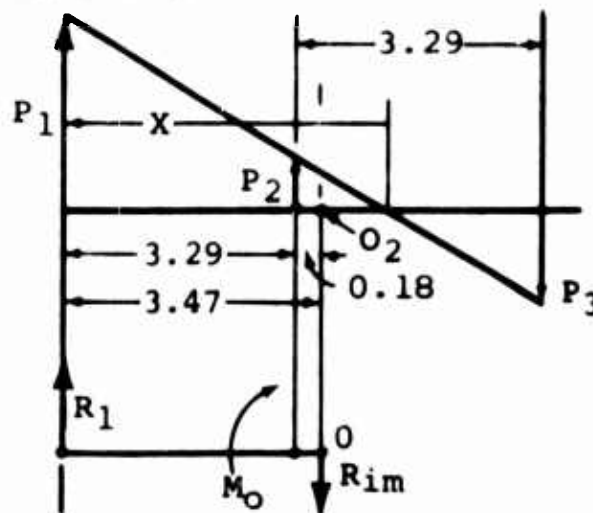

FIGURE 32

R_1 and R_{1M} are oppositely directed. By exchanging R_{im} with forces P_2 and P_3 , it can be seen that P_3 is much less than R_{im} because P_3 acts on a larger arm. Thus the rotation point of the chair body is accepted further to the right of the center in order to retain the original condition of equilibrium.

$$\Sigma Z \quad R_1 - R_{im} = P_1 + P_2 - P_3$$

and

$$\Sigma M_{O_2} R_1 \cdot 3.47 + R_{im} \cdot 0 = P_1 \cdot 3.47 + P_2 \cdot 0.18 + P_3 \cdot 3.11$$

(ΣM_{O_2} is point 4 in Figure 29).

Introducing x ,

$$\frac{P_2}{P_1} = \frac{x}{x - 3.29} \text{ and } \frac{P_3}{P_1} = \frac{6.58 - x}{x}$$

and

$$P_2 = \frac{x}{x - 3.29} P_1 \quad P_3 = \frac{6.58 - x}{x} P_1$$

and

$$R_1 = -3034$$

$$R_{im} = +1600$$

$$R_1 - R_{im} = -1434 \text{ pounds (the sign is unimportant).}$$

$$1434 = P_1 \left(1 + \frac{x}{x - 3.29} - \frac{6.58 - x}{x} \right)$$

and

$$1.053 \times 10^4 = P_1 \left(3.47 + \frac{x}{x - 3.29} 0.18 + \right.$$

$$\left. \frac{6.58 - x}{x} 3.11 \right)$$

A grapho-analytical method is used as follows:

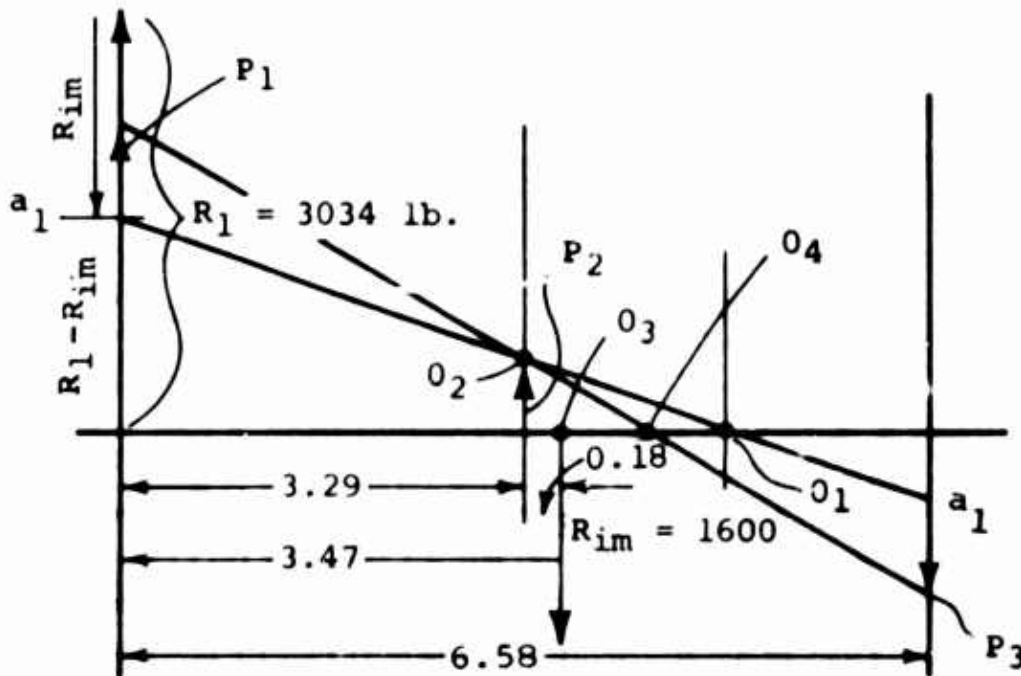

FIGURE 33

The R_1 and R_{im} forces are exchanged through P_1 , P_2 and P_3 . The first solution is that $P_1 = R_1 - R_{im}$. Remaining forces must cancel one another, as far as

$$P_1 + P_2 + P_3 = R_1 - R_{im}$$

This cancellation may be performed graphically with reference to Figure 33 above. A line is drawn through the middle of the half span (point O_1).

Then,

$$P_2 = P_3 = \frac{R_1 - R_{im}}{3} = \frac{3034 - 1600}{3} =$$

478 pounds.

This satisfies the first condition $\sum Z = 0$. Taking half of the moments around point O_3 , it is seen that

$$1434 \times 3.47 + 478 \times 0.18 + 478 \times 3.11 = 6550 \text{ lb}$$

which is too small to satisfy the condition
 $M = R_1 \cdot 3.47$.

$$6550 < 3034 \times 3.47$$

$$6550 < 10,500$$

The difference, $10,500 - 6,500 = 3,944$.

Now, rotating line a_1-a_1 , the moment is increased, introducing Δ which is found to be

$$\Delta = \frac{M_1 - M_2}{6.58} = \frac{3944}{6.58} = 600$$

then,

$$P_1 = 1434 + \Delta$$

$$P_2 = 478$$

$$P_3 = -(478 + \Delta)$$

thus

$$\begin{array}{l} P_1 = 2034 \text{ pounds} \\ P_2 = 478 \text{ pounds} \\ P_3 = 1078 \text{ pounds} \end{array} \left. \begin{array}{l} \\ \\ \end{array} \right\} \begin{array}{l} \text{tension in struts} \\ \text{\textcircled{1}} \text{ and } \text{\textcircled{2}} \\ \text{compression in} \\ \text{strut } \text{\textcircled{3}} \end{array}$$

Inasmuch as these values of P_1 , P_2 and P_3 satisfy both equations, the P_1 , P_2 and P_3 are true forces of the system.

7.18 The Loads -5q(Down), 95th Percentile Man - By analogy with Section 7.9,

$$\begin{array}{l} P_1 = -2034 \text{ pounds} \\ P_2 = -478 \text{ pounds} \\ P_3 = +1078 \text{ pounds} \end{array} \left. \begin{array}{l} \\ \\ \end{array} \right\} \begin{array}{l} \text{compression in} \\ \text{struts } \text{\textcircled{1}} \text{ and } \text{\textcircled{2}} \\ \text{tension in strut } \text{\textcircled{3}} \end{array}$$

- 7.19 The loads given in 7.8, 7.9, 7.17, 7.18 are total loads on Trussgrid blocks and, since the blocks are used in pairs, the load per block is half of the given values for P_1 , P_2 and P_3 .

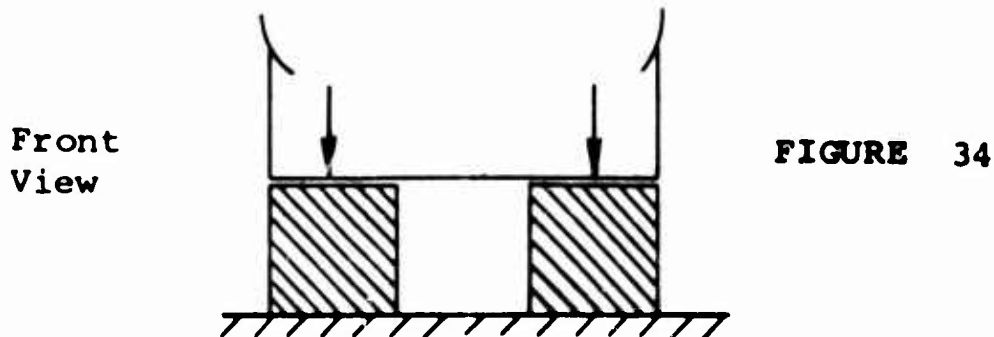

- 7.20 The comparison between 5th percentile man loading and 95th percentile man loading indicates that the latter case is much more severe, not as much due to the heavier weight of the man (200 pounds as opposed to 136 pounds) as to the less favorable force distribution in the system.

8. CRASH IMPACT LOADS

General Considerations

Case as described in Section 2.2 above, 25g, load downward, attenuation due to destruction of the Trussgrid blocks. Previous analyses indicated that the pair of front blocks carry the largest load. Thus the destruction of the Trussgrid blocks starts with the front blocks. Evidently, just as the crash load occurs, the loads on the front blocks exceed the crushing loads and the front block gives away, thus causing the chair to rotate around the screw jack attachment point, its pivot point, or both. In any case, the top of the chair moves violently away from the restraint straps anchor points, thus immediately engaging the inertial reels which will lock the restraint straps (see Section 6.3). This circumstance changes entirely the motion of the chair. The chair becomes part of a 4-link mechanism and moves so as to remain parallel to its original position

until the difference in radii of rotation of the restraint straps and adjusting screw jack introduces slant to the back of the chair.

The initial crushing loads must be determined, in order to design the Trussgrid blocks accordingly. Calculations will be performed for both the 5th and 95th percentile men, in order to prevent design of the Trussgrid blocks to too great a strength.

8.1 The 5th Percentile Man - The weights remain the same as those shown in Section 7.1.

8.2 The Loads at -25G (Down) -

$$W_m = 130 \times 25 = 3250 \text{ pounds}$$

$$W_s = 88 \times 25 = 2200 \text{ pounds}$$

$$W_p = 26 \times 25 = 650 \text{ pounds}$$

8.3 Resulting Force -

$$W_R = W_m + W_s + W_p = 6100 \text{ pounds}$$

8.4 The location of the resulting force is the same as that indicated in 7.5.

8.5 Assumptions - The assumptions of Section 7.2 above remain valid except for assumption c. As indicated in Sections 8, 6.2 and 6.3 above, the condition of load distribution changes entirely in the instant just prior to deformation and after the front Trussgrid blocks begin to deform. Therefore, four cases must be considered:

1. The instant just prior to attenuation
2. The instant just after attenuation has started

3. The instant just prior to total engagement of the Trussgrid blocks with adjacent surfaces.
4. The last stage of attenuation.

In the first case, the assumption c of Section 7.2 is valid; the restraint straps exercise no appreciable load on the seat. In the second, third and fourth cases, the assumption c is invalid, and these cases will be investigated separately.

8.6 The Condition Just Prior to Attenuation (see Figure 35) - Following the principle of proportionality of loads and reactions within limit of proportionality, using the method of calculation shown in Sections 7.6, 7.7, 7.8 and 7.9, loads distribution for the Trussgrid block are determined.

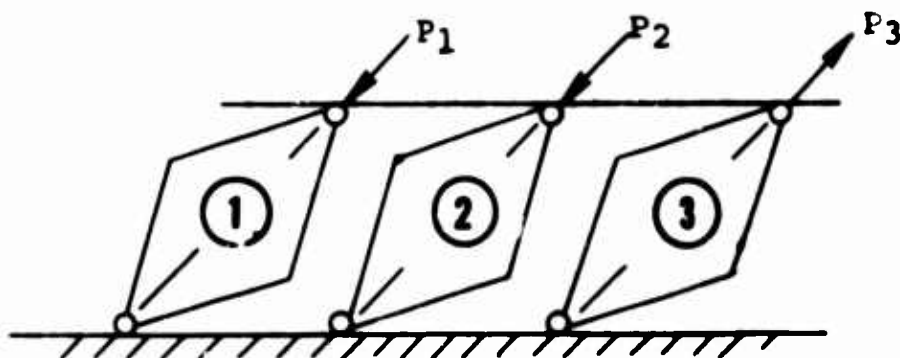

FIGURE 36

$$\begin{array}{rcl}
 P_1 = 674 \times 5 = -3370 \text{ pounds} & \left. \vphantom{P_1} \right\} & \text{compression} \\
 P_2 = 331 \times 5 = -1650 \text{ pounds} & \left. \vphantom{P_2} \right\} & \text{load} \\
 P_3 = +40.5 \times 5 = +200 \text{ pounds} & \left. \vphantom{P_3} \right\} & \text{tension load}
 \end{array}$$

8.7 The Condition After Attenuation has Started (The Trussgrid Blocks Started to be Deformed) - The locked restraint straps, adjusting screw jack, structure of the aircraft and seat itself form a 4-member mechanism. Inasmuch as at the beginning

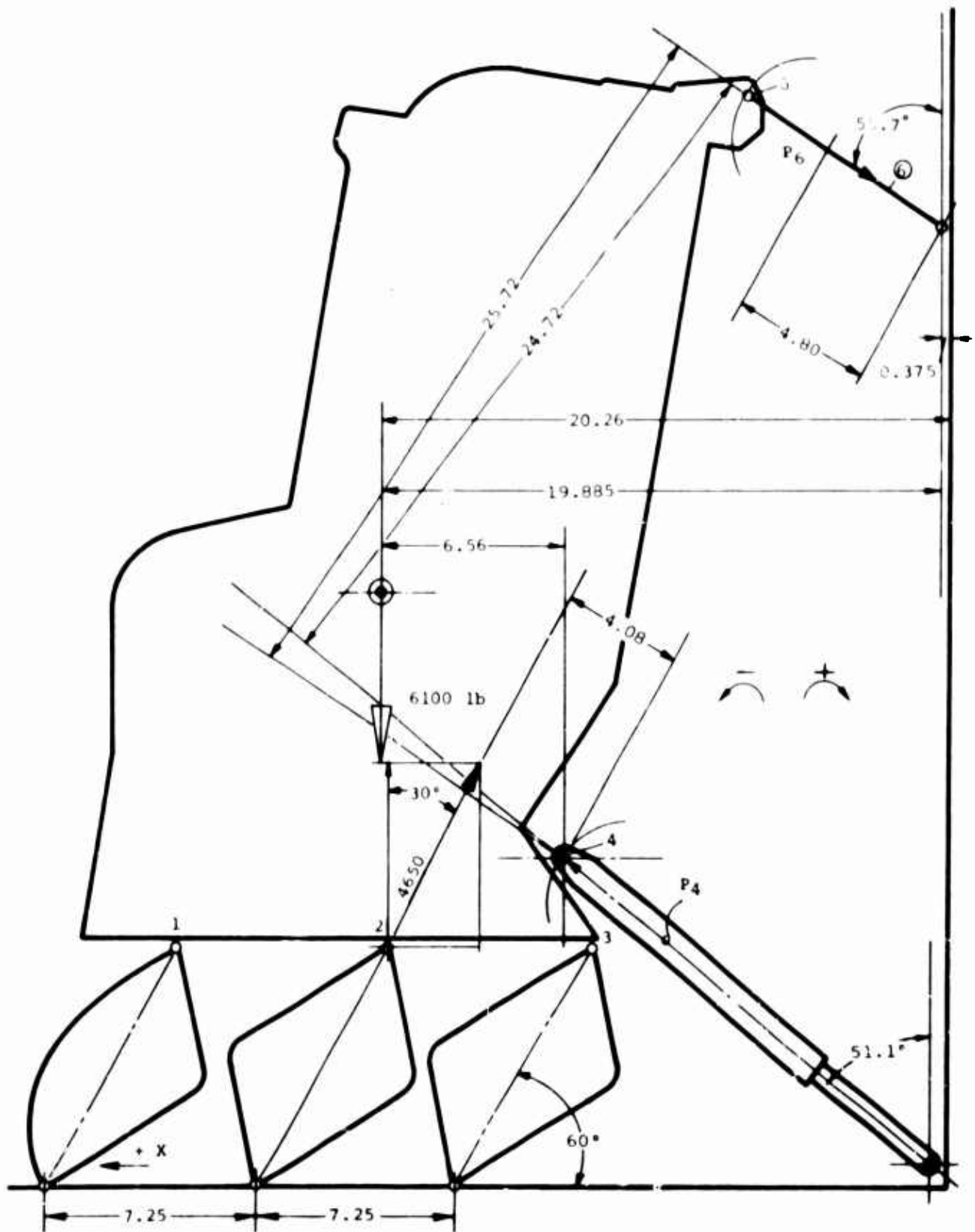

FIGURE 35

of the motion down, only motion parallel to the original seat position is possible, the Trussgrid blocks will be loaded evenly; thus the position

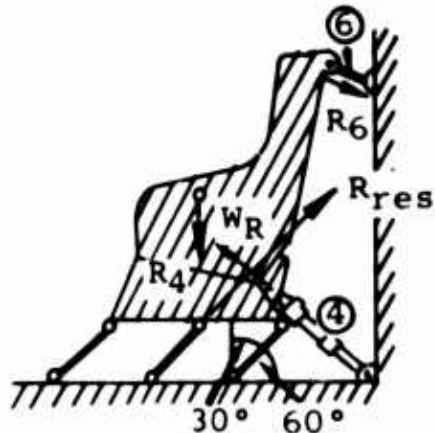

FIGURE 37

and direction of the reaction is known. This will be true, assuming that the elongations of the restraint straps are negligible in comparison with the deflections of the Trussgrid blocks.

$$\Sigma X = 0,$$

$$-6100 + R_{res} \cos 30 + P_4 \cos 51.1 - P_6 \cos 55.7^\circ = 0 \quad (1)$$

$$\Sigma Z = 0,$$

$$0 - R_{res} \sin 30 + P_4 \sin 51.1 - P_6 \sin 55.7^\circ = 0 \quad (2)$$

$$\Sigma M_4 = 0,$$

$$-6100 \cdot 6.56 + R_{res} 4.08 + P_6 24.72 = 0 \quad (3)$$

From eq. (1),

$$R_{res} \cos 30 = 6100 - P_4 \cos 51.1 + P_6 \cos 55.7, \text{ and}$$

$$R_{res} = \frac{6100}{\cos 30} - P_4 \frac{\cos 51.1}{\cos 30} + P_6 \frac{\cos 55.7}{\cos 30} \quad (4)$$

From eq. (2),

$$-R_{res} \sin 30 = +P_6 \sin 55.7 - P_4 \sin 51.1, \text{ or}$$

$$R_{res} = +P_4 \frac{\sin 51.1}{\sin 30} - P_6 \frac{\sin 55.7}{\sin 30} \quad (5)$$

From eq. (3)

$$-R_{res} \cdot 4.08 = 40,000 - P_6 \cdot 24.72$$

$$R_{res} = \frac{40,000}{4.08} - P_6 \frac{24.72}{4.08} \quad (6)$$

Then

$$R_{res} = 7030 - P_4 \frac{0.628}{0.866} + P_6 \frac{0.5638}{0.866}$$

$$R_{res} = 7030 - 0.725 P_4 + 0.651 P_6 \quad (7)$$

and,

$$R_{res} = +P_4 \frac{0.778}{0.50} - P_6 \frac{0.826}{0.50}$$

$$R_{res} = 1.56 P_4 - 1.652 P_6 \quad (8)$$

and,

$$R_{res} = 9,800 - P_6 6.06 \quad (9)$$

Combining eqs (7) and (8),

$$7030 - 0.725 P_4 + 0.651 P_6 = 1.56 P_4 - 1.652 P_6$$

$$P_6(0.651 + 1.652) = P_4(1.56 + 0.725) - 7030$$

$$P_6 2.303 = P_4 2.285 - 7030$$

$$P_6 = P_4 \frac{2.285}{2.303} - \frac{7030}{2.303}$$

$$P_6 = 0.993 P_4 - 3050 \quad (10)$$

Combining eqs (7) and (9),

$$7030 - 0.725 P_4 + 0.651 P_6 = 9,800 - P_6 6.06$$

$$P_6(0.651 + 6.06) = 9,800 - 7,030 + 0.725 P_4$$

$$P_6 = \frac{2770 + 0.725 P_4}{6.711} = 413 + 0.108 P_4 \quad (11)$$

Comparing eqs (10) and (11),

$$0.993 P_4 - 3050 = 413 + 0.108 P_4$$

$$P_4(0.993 - 0.108) = 413 + 3050$$

$$P_4 = \frac{3463}{0.885} = 3920 \text{ pounds} \quad (12)$$

$$P_6 = 0.993 \times 3920 - 3050 = 850 \text{ pounds} \quad (13)$$

And from eq. (10),

$$R_{res} = 9,800 - 6.06 \times 850 = 4650 \text{ pounds} \quad (14)$$

After the original tilt forward, the chair will assume a parallel motion, being restrained by the locked restraint straps. The translations of point 1, 2 and 3 will thus become identical, consequently, causing identical forces. Therefore, the resulting force $R_{res} = 4650$ pounds will be evenly distributed between 3 blocks along the chair side. This redistribution of the resulting force will be very rapid and irrevocable. Should the load in the restraint straps lessen, due to the reaction of the Trussgrid blocks, the immediate redistribution of the crushing load on the front blocks will follow, causing forward tilt of the chair, immediate engagement of the locks of the restraint straps, and return to parallel motion again. The load on one block (acting actually on a pair of blocks) will then be

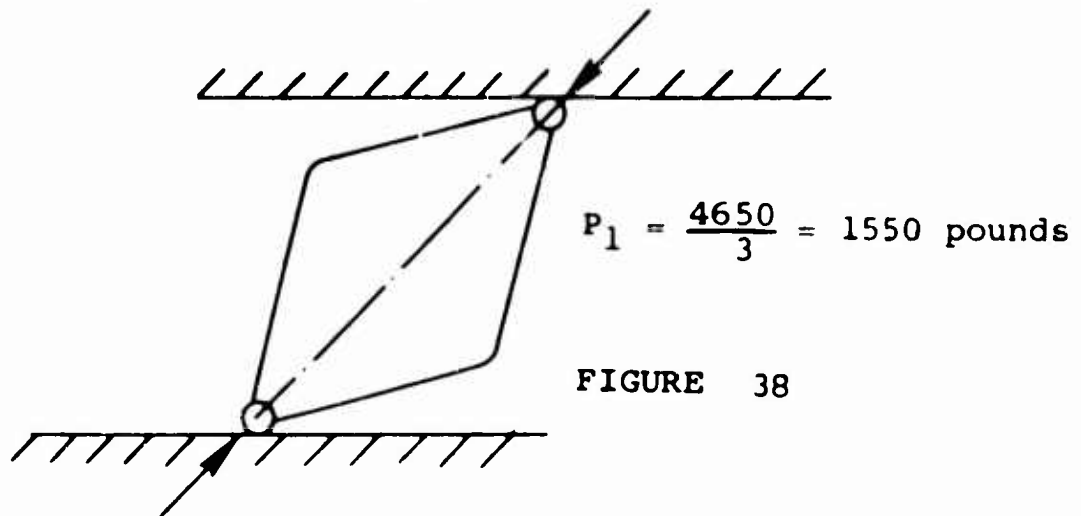

FIGURE 38

This load is less than the design load for the case of maneuver loads with a 95th percentile man occupying the chair. According to section 7.17, the load which the Trussgrid blocks must be able to withstand without deforming is almost 2000 pounds.

This is, however only a seeming inconsistency. At impact, a 3000-pound transient load is exerted on the front Trussgrid blocks. This load will begin to crush the front blocks inasmuch as the blocks will be designed to withstand a load of approximately 2000 pounds. In the next moment, the restraint straps will be engaged and will pull the chair backwards, shifting the load onto the middle and rear Trussgrid blocks. Inasmuch as the front blocks already received deformation, it would be proper to divide the full load onto 2 blocks (middle and rear). Then,

$$P_2 + P_3 = 4650 \text{ pounds, or}$$

$$P_2 = 2325 \text{ pounds}$$

This 2325 pounds represents that load under which the Trussgrid block must begin to collapse. Thus, the load limitation for the design of the Trussgrid blocks is established.

Design Load for Trussgrid Block (One Side Only) -

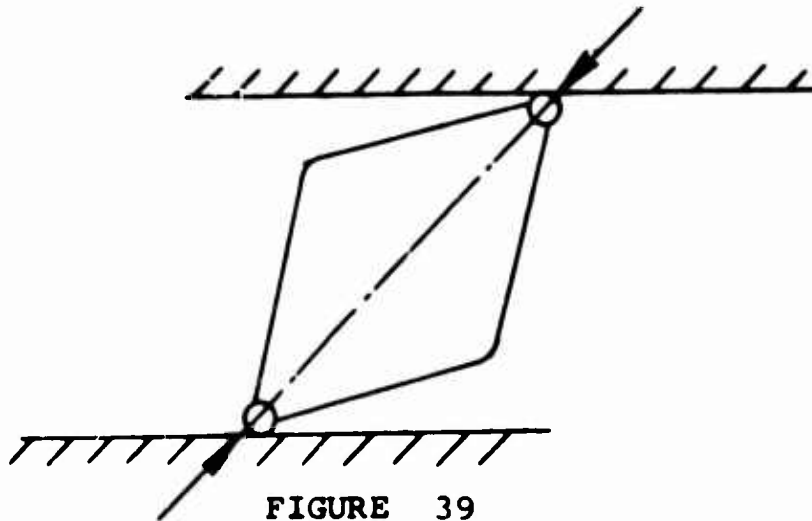

FIGURE 39

Limit load - 1000 pounds

Ultimate load - 1050 to 1100 pounds

The properties of honeycomb structures in general are quite suitable to satisfying rigid strength requirements of shock absorbing elements. The honeycomb structures, including Trussgrid, being structures whose strengths are based upon local buckling strength, have an increased strength prior to a first collapse of the local web somewhere in the structure. The typical stress-strain diagram for honeycomb materials is shown below:

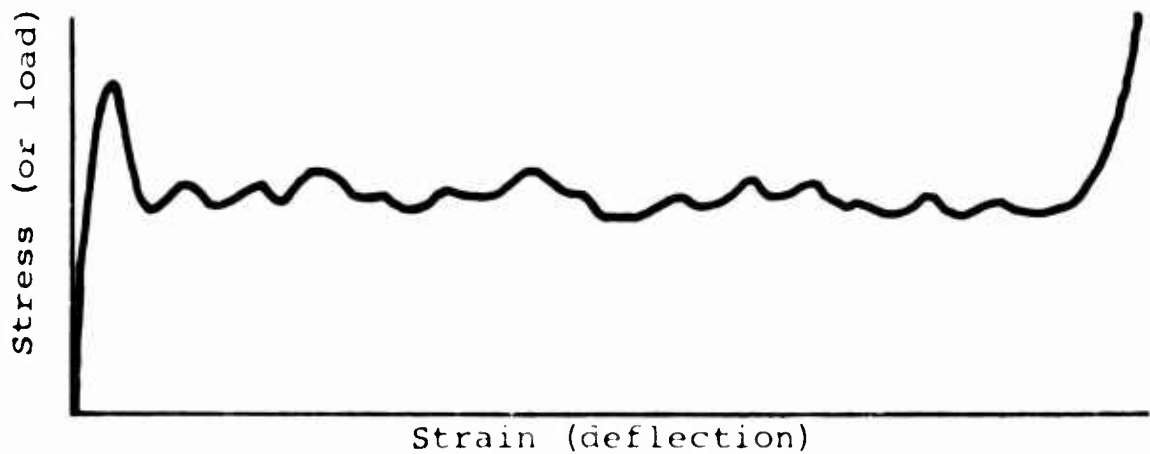

FIGURE 40

- 8.8 The Condition Just Prior to Total Engagement of the Trussgrid Blocks - The next condition to be investigated is the position of the chair just prior to total engagement of the Trussgrid blocks. The vertical travel of the chair is 4 inches, and this position is shown in Figure 41. The Trussgrid blocks are largely deformed. The direction of the resultant force from the Trussgrid blocks on the chair is unknown. However, by definition, the forces shall act through the pivot points of the blocks. It is reasonable to assume that the resultant of each block still goes through these points. The downward travel of the chair is nearly parallel to the original position of the chair. The maximum deviation from parallel travel is about 0.2 inch for 4 inches of total travel or

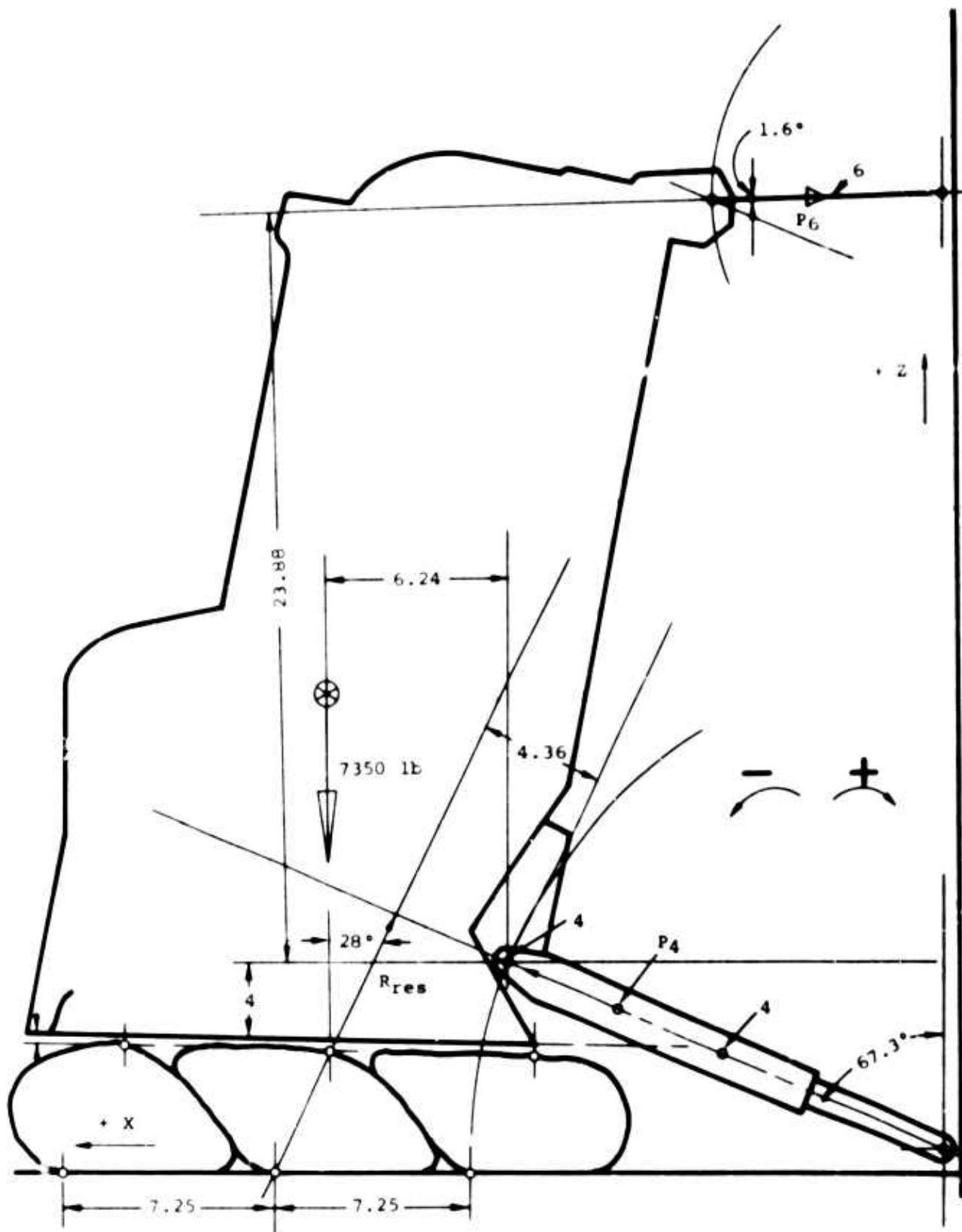

FIGURE 41

about 5 percent; this deviation may be ignored.

It is proper to assume that the reactions of each block are approximately equal. The forces acting on the chair from the Trussgrid block may thus be exchanged with one resultant force. Such a system of forces can readily be solved as follows:

Assuming $\sum Z = 0$

$$-6100 + R_{res} \cos 28 + P_4 \cos 67.3 + P_6 \cos 88.4 = 0 \quad (1)$$

Assuming $\sum X = 0$

$$0 - R_{res} \sin 28 + P_4 \sin 67.3 - P_6 \sin 88.4 = 0 \quad (2)$$

Assuming $\sum M_4 = 0$

$$-6100 \times 6.24 + R_{res} 4.36 + P_6 23.88 = 0 \quad (3)$$

From eq. (1)

$$R_{res} \cos 28 = 6100 - P_4 \cos 67.3 - P_6 \cos 88.4$$

and

$$R_{res} = \frac{6100}{\cos 28} - P_4 \frac{\cos 67.3}{\cos 28} - P_6 \frac{\cos 88.4}{\cos 28} \quad (4)$$

From eq. (2)

$$-R_{res} \sin 28 = + P_6 \sin 88.4 - P_4 \sin 67.3$$

and

$$R_{res} = +P_4 \frac{\sin 67.3}{\sin 28} - P_6 \frac{\sin 88.4}{\sin 28} \quad (5)$$

From eq. (3)

$$R_{res} \times 4.36 = 38100 - P_6 \ 23.88$$

$$R_{res} = \frac{38100}{4.36} - P_6 \frac{23.88}{4.36} \quad (6)$$

Then,

$$R_{res} = \frac{6100}{0.8829} - P_4 \frac{0.386}{0.883} - P_6 \frac{0.028}{0.883}$$

and,

$$R_{res} = 6920 - P_4 \ 0.437 - P_6 \ 0.0317 \quad (7)$$

and,

$$R_{res} = + P_4 \frac{0.9225}{0.4695} - P_6 \frac{0.9996}{0.4695}$$

$$R_{res} = + 1.965 P_4 - 2.126 P_6 \quad (8)$$

and,

$$R_{res} = 8730 - 5.48 P_6 \quad (9)$$

Combining eqs. (7) and (8),

$$6920 - 0.437 P_4 - 0.0317 P_6 = 1.965 P_4 - 2.126 P_6$$

$$+ P_6 (2.126 - 0.0317) = P_4 (1.965 + 0.437) - 6920$$

$$P_6 \ 2.094 = 2.4 P_4 - 6920$$

$$P_6 = P_4 \frac{2.4}{2.1} - \frac{6920}{2.1}$$

and,

$$P_6 = 1.14 P_4 - 3290 \quad (10)$$

Combining eqs. (7) and (9),

$$10920 - 0.437 P_4 - 0.0317 P_6 = 8730 - 5.48 P_6$$

$$P_6 (5.48 - 0.0317) = 8730 - 6920 + 0.437 P_4$$

$$5.45 P_6 = 1810 + 0.437 P_4$$

and,

$$P_6 = \frac{1810}{5.45} + \frac{0.437}{5.45} P_4 = 332 + 0.0803 P_4 \quad (11)$$

Comparing eqs. (10) and (11),

$$1.14 P_4 - 3290 = 332 + 0.0803 P_4$$

$$P_4 (1.14 - 0.0803) = 332 + 3290$$

$$P_4 = \frac{3622}{1.06} = 3420 \text{ pounds} \quad (12)$$

$$P_6 = 1.14 \times 3420 - 3290 = 610 \text{ pounds} \quad (13)$$

And from eq. (9),

$$R_{res} = 8730 - 5.48 \times 610 = 5390 \text{ pounds} \quad (14)$$

Loads are less at the beginning of attenuation, as expected.

- 8.9 The Last Stage of Attenuation - The ultimate down position of the chair is determined by the collapsing properties of the Trussgrid blocks and the honeycomb base of the chair, which in the last stage of impact is crushed. Accepting data derived from tests of Trussgrid that indicate 85 percent collapsibility, the position of the chair is determined, as indicated in Figure 42.

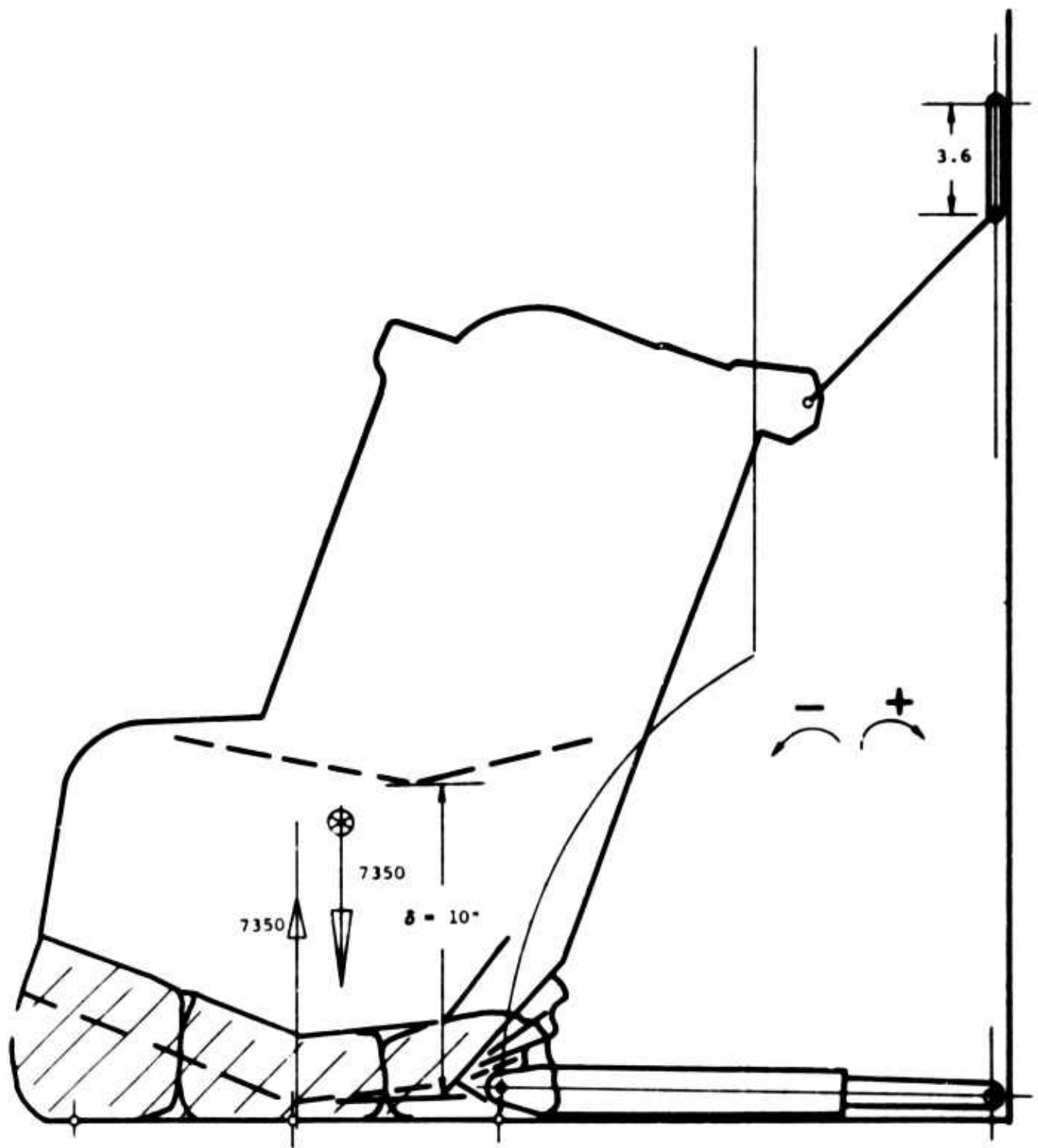

FIGURE 42

- 8.10 The movement of the chair completely down is possible due to the slotted hole at the anchor bracket of the restraint straps. This vertical slot, of course, alters the direction of reactions P_6 (the component of P_6 on axis Z will be 0).

The reaction of the Trussgrid blocks and honeycomb base of the chair will take a more or less vertical direction, and thus will produce very small (if any) moment with g force, and consequently very small forces in the restraint straps and adjusting screw jack.

- 8.11 The total travel during impact for the case of the 5th percentile man is

$$\delta = 10 \text{ inches}$$

- 8.12 If the resultant reaction force produces negative moment (see Figure 42), the restraint straps will immediately develop a tension force and will retain the chair in somewhat of a deflected position from that illustrated in Figure 42.

- 8.13 If the resultant force produces a positive moment (see Figure 42), the restraint strap will slacken momentarily, and will then tighten as the seat top nears the bulkhead. The strap then provides a restraining force to stabilize the seat.

- 8.14 The load on the Trussgrid blocks is equal to the full g load downward, and numerically is

$$W_r = 6100 \text{ pounds.}$$

- 8.15 The force in the adjusting screw jack in the last moment of impact is approaching zero (from the inertial forces). However, there could be a significant addition to the varying inertial forces, due to shear of the whole Trussgrid block system. The magnitude of shear resistance during

crushing is not known and requires additional experimental investigation.

8.16 The 95th Percentile Man - The weights remain the same as those shown in section 7.10.

8.17 The Loads at -25 (Down) -

$$W_m = 200 \times 25 = 5000 \text{ pounds}$$

$$W_s = 88 \times 25 = 2200 \text{ pounds}$$

$$W_p = 26 \times 25 = 650 \text{ pounds}$$

8.18 Resulting Force -

$$W_R = W_m + W_s + W_p = 7850$$

8.19 The location of the resulting force is the same as that indicated in section 7.14.

8.20 Assumptions - The assumptions of section 7.2 above remain valid except for assumption c. As discussed in section 8.5, four cases must be considered, since the condition of load distribution changes. For the instant prior to attenuation, assumption c is valid; for the other cases, the assumption is invalid and reasoning as discussed in sections 8.7, 8.8 and 8.9 must be employed.

8.21 The Condition Just Prior to Attenuation - Through analogy with section 8.6, loads P_1 , P_2 , and P_3 (see section 7.18) may be multiplied by 5 to yield loads due to inertia in the case of 25 g down forces for the 95th percentile man.

$$P_1 = 2034 \times 5 = 10650 \text{ pounds}$$

$$P_2 = 478 \times 5 = 2400 \text{ pounds}$$

$$P_3 = -1078 \times 5 = -5400 \text{ pounds}$$

Evidently, the Trussgrid blocks start to collapse immediately, since they are not designed to withstand such a heavy load.

8.22 The Condition After Attenuation Has Started - As was shown in section 8.7, the restraint straps are immediately engaged (see Figure 30). The resultant force from the side of the Trussgrid blocks is applied at the middle of the blocks, and due to the geometry, passes very close to the adjusting screw jack pivot point. In order to simplify calculation, the R_{res} is assumed to pass exactly through point 4. This simplification permits P_6 to be readily determined.

$$7850 \times 6.88 = P_6 \times 27.04$$

$$P_6 = \frac{54,000}{27.04} = 2000 \text{ pounds}$$

$$\Sigma Z = 0$$

$$-7850 - P_6 \cos 78.7 + Z = 0$$

$$Z = 7850 + 2000 \quad 0.1959 = 8242 \text{ pounds}$$

$$\Sigma X = 0$$

$$0 - P_6 \sin 78.7 + X = 0$$

$$X = +2000 \quad 0.9810 = 1962 \text{ pounds}$$

In relation to the chair body, Z is upward and X is toward the left (both systems positive). The trusses (4) and (2) are loaded oppositely.

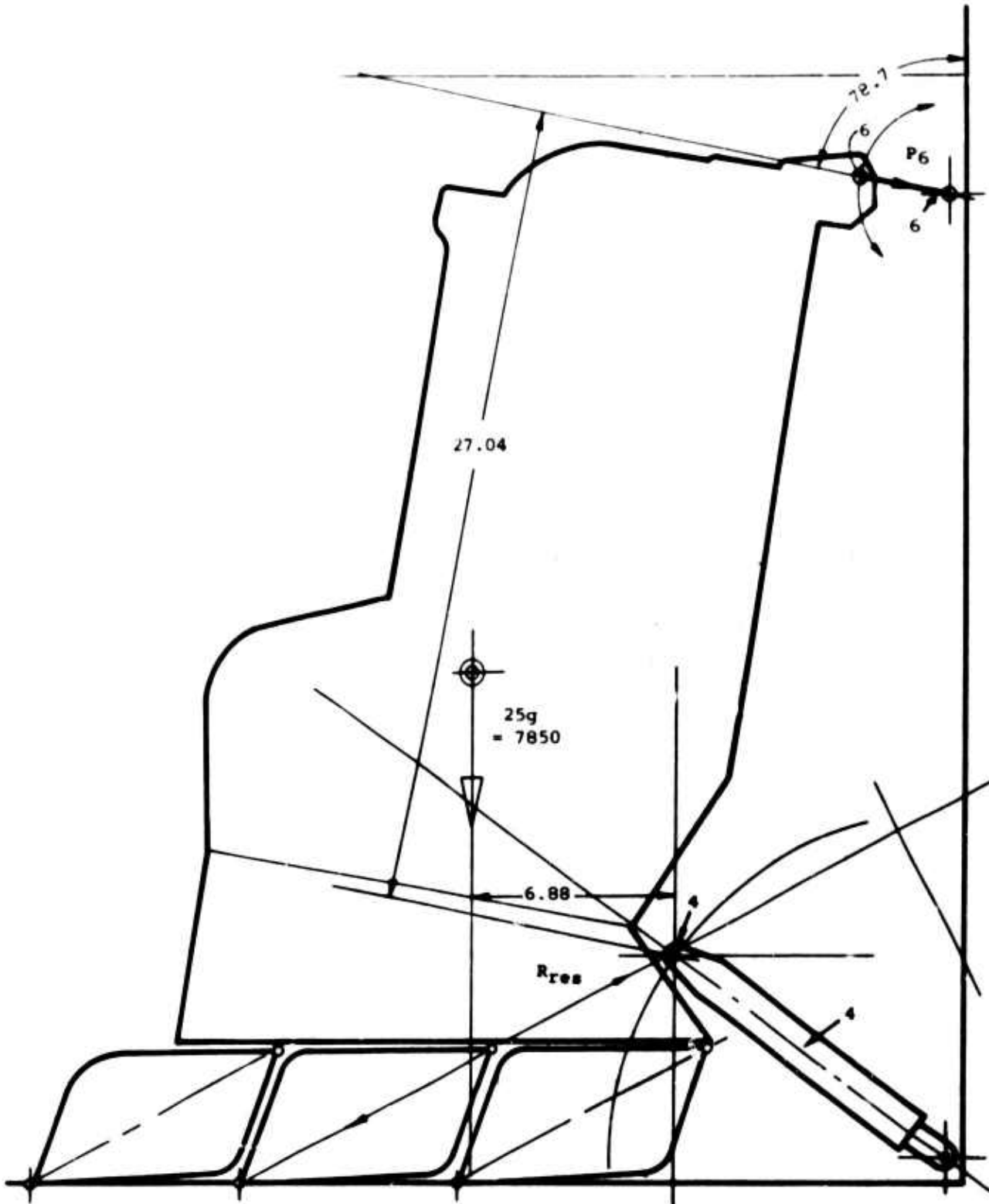

FIGURE 43

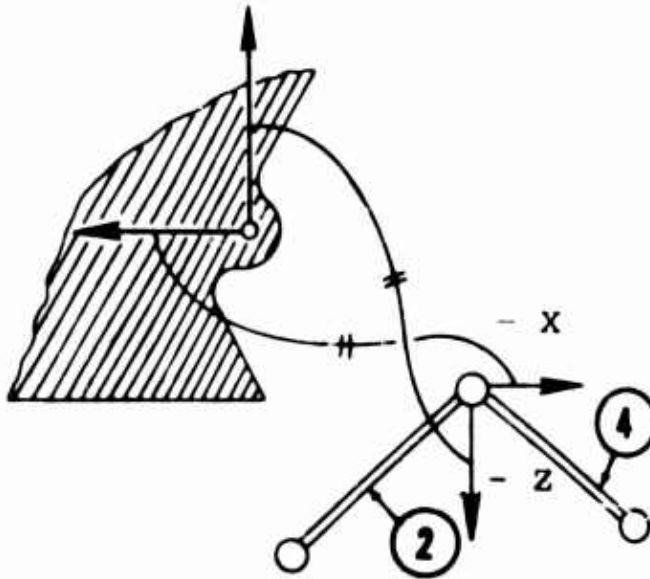

FIGURE 44

Resolving on the struts,

in strut ④ (adjusting screw jack), resultant = 9200 pounds, compression in strut ②, resultant = 6200 pounds, compression or for each pair of blocks,

$$P_1 = P_2 = P_3 = \frac{6220}{3} = 2070 \text{ pounds}$$

In comparison with section 8.7 (5th percentile man), the average load is greater here. The considerations discussed in section 8.7 for selection of design loads for Trussgrid blocks therefore remain unaltered.

8.23 Condition Just Prior to Total Engagemnt of the Trussgrid Blocks - Due to the geometry of the chair at adjustment for the 95th percentile man, this condition is very similar to that discussed above for the 5th percentile man. There is no necessity, therefore, to analyze this case separately (see section 8.8).

8.24 The Last Stage of Attenuation - By analogy to sections 8.9 and 8.10, the chair assumes the position illustrated in Figure 45.

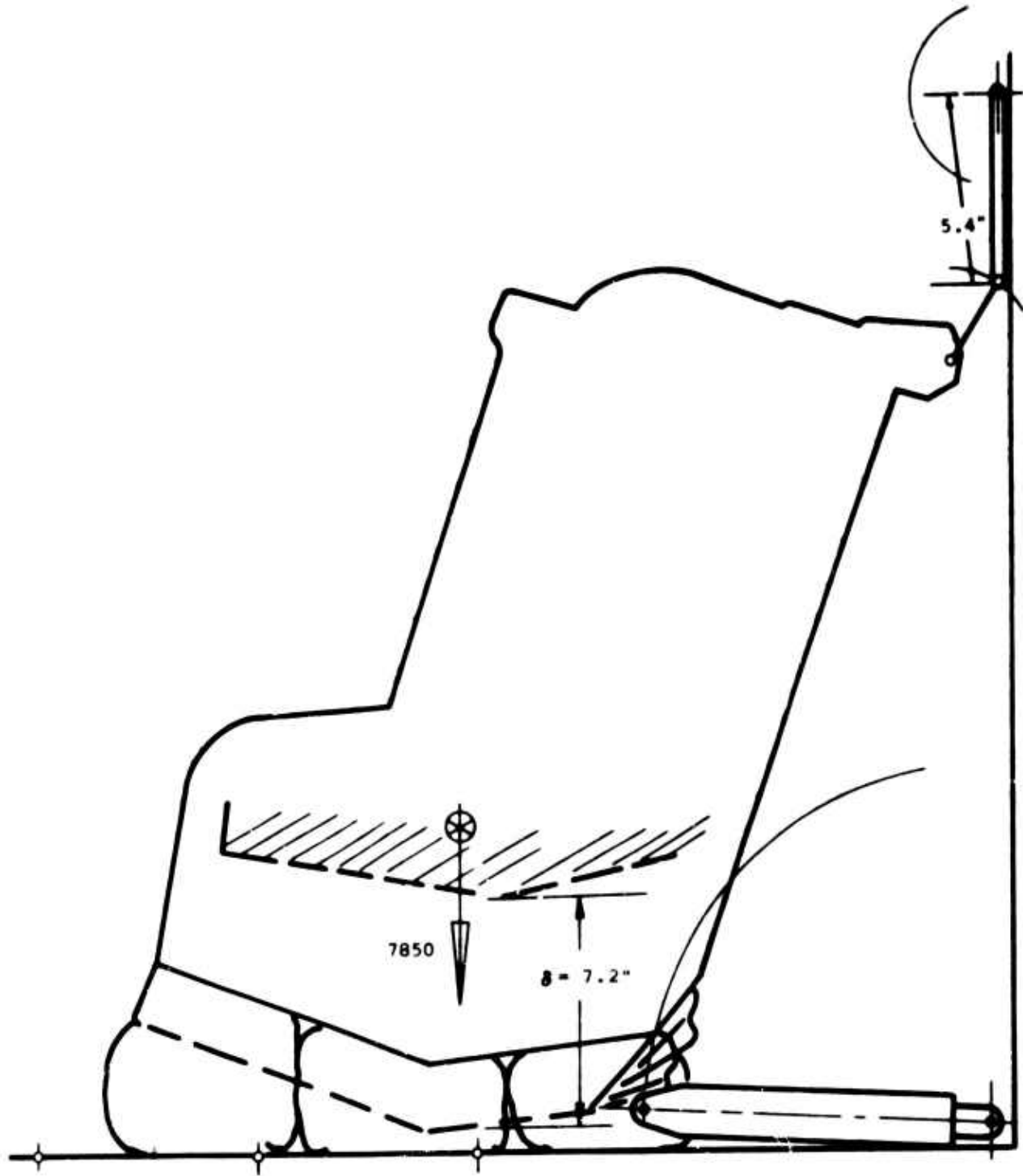

Figure 45

8.25 The total travel during impact for the case of the 95th percentile man is

$$\delta = 7.2 \text{ inches}$$

8.26 The considerations expressed in Section 8.13 for the case of 5th percentile man are valid in the case of the 95th percentile man.

8.27 The load on the Trussgrid blocks is equal to full g load downward, and numerically is

$$W_r = 7850 \text{ pounds}$$

8.28 The considerations expressed in Section 8.15 are valid for the case of the 95th percentile man.

9. ENERGY ABSORPTION DURING IMPACT

The deformation of the adjusting screw jack and restraint straps has been neglected; therefore, the strain energy absorbed by these members may be neglected also. Thus, the total energy absorption during attenuation may be attributed to deformation of the Trussgrid blocks.

9.1 To consider the total energy absorption due to vertical movement of the chair during attenuation, a rough approximation is required. The chair not only moves vertically, but also follows a path of motion determined by the adjusting screw jack.

In calculating the energy absorption along the path of motion, shear will be taken into account.

$$s = S$$

$$\text{Energy absorption} = \sum W_r \Delta s$$

$$s = 0$$

To compute this sum, the change of resultant W_r versus the path of motion must be known.

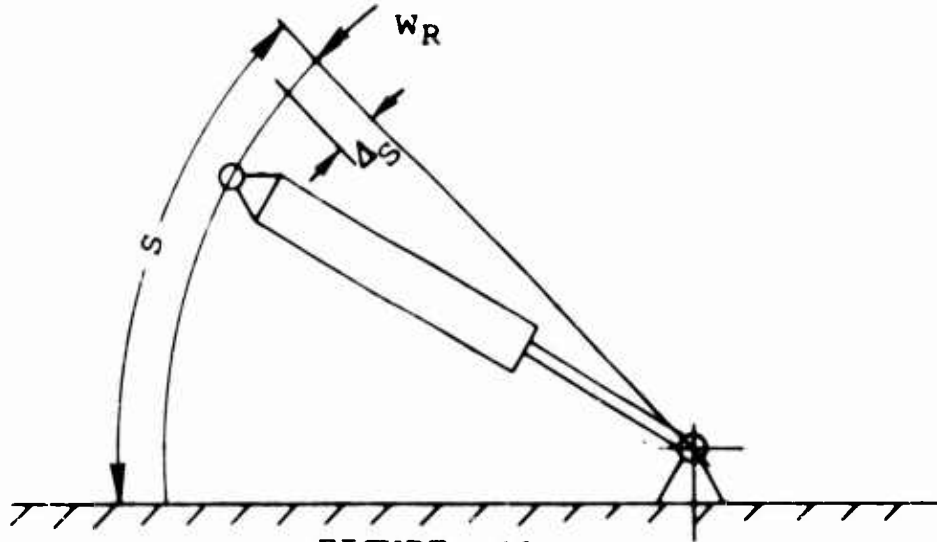

FIGURE 46

- 9.2 Energy Absorbed in Impact, 5th Percentile Man in Seat - The trajectory of motion is shown in Figure 47. Figure 48 is a diagram of the change in reaction force versus the deformation path.
- 9.3 The change of forces P_1 , P_2 and P_3 versus the deformation path is shown in Figure 48. From this diagram, the total energy absorption by the Trussgrid blocks and honeycomb structure of the seat base may be calculated.

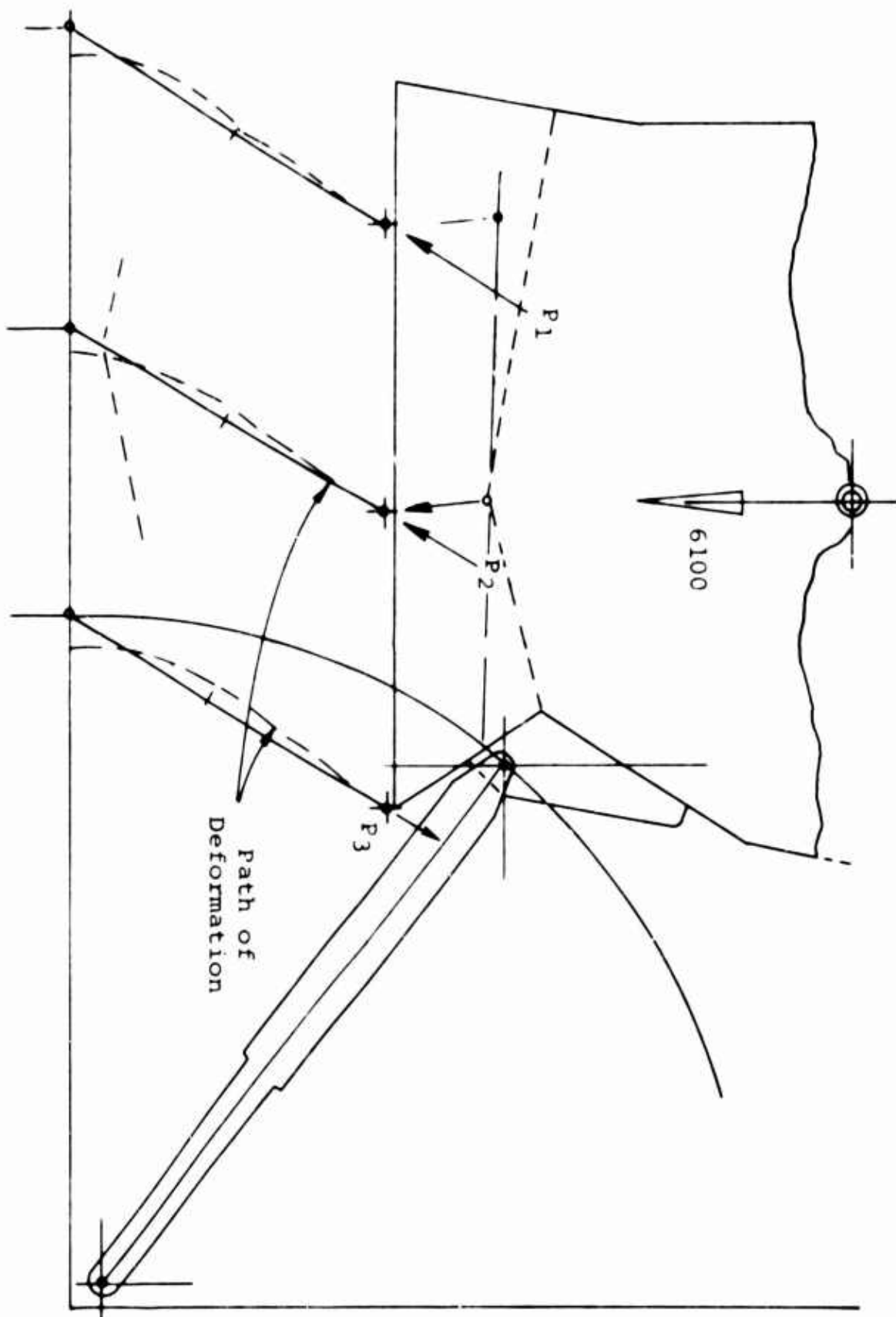

FIGURE 47

Force In Blocks vs Deformation

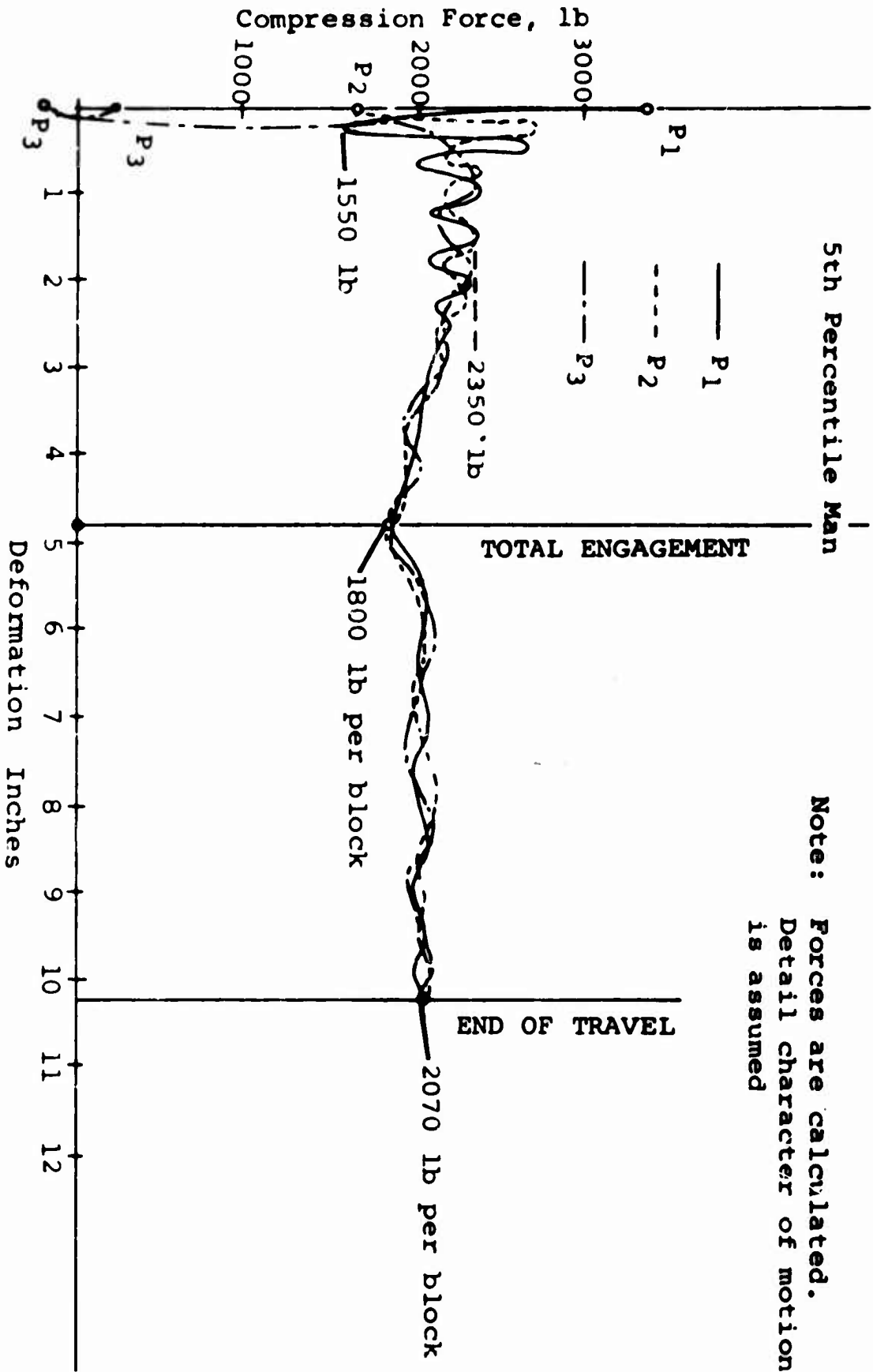

FIGURE 48

Path, in.	P ₁	P ₂	P ₃
1	2200	2050	1600
2	2350	2350	2300
3	2180	2180	2150
4	1900	1900	1900
5	1860	1860	1860
6	2000	2000	2000
7	2070	2070	2070
8	2070	2070	2070
9	2070	2070	2070
10	2070	2070	2070
0.2	414	414	414
ΣE	21,184	21,034	20,504
$\Sigma Total$	62,722 lb.- in.		

9.4 Considering the entire system from the viewpoint of the pilot during crash impact, the system must provide a resisting force of not more than 6100 pounds upwards to cause 25 g load on the pilot. The total energy absorbed by a vertical movement only will then be

$$E_{t_z} = 6100 \times 10 = 61,000 \text{ lb.-in.}$$

The actual energy absorbed (see section 9.3) is

$$E_{total} = 63,000 \text{ lb.-in.}$$

The difference in this case is slight:

$$\frac{2000}{61000} = 3.2\%$$

This percentage of difference must be kept as small as possible, since each cubic inch of Trussgrid structure could absorb a certain amount of energy. The volume and loading factor must be selected in such a manner that the total energy absorption capability of the system is not much greater than required. Otherwise, the system could not be guaranteed to produce a desired g load on the seat occupant, nor could it be ensured that the g load would remain constant during impact.

9.5 Calculation of the Average Sink Speed During Impact, G Load Constant - The total energy of vertical motion,

$$E_{t_z} = 61,000 = Wh + 1/2mV^2$$

Therefore,

$$v^2 = \frac{(61,000 - Wh)2}{W/g}$$

Where

$$W = 244 \text{ pounds}$$

$$g = 32.3 \text{ ft/sec}^2 \text{ or } 386 \text{ in/sec}^2$$

$$h = 10 \text{ inches (vertical travel)}$$

Thus,

$$v^2 = \frac{58,560 \times 2 \times 386}{244}$$

$$V = 18,500$$

$$V = 430 \text{ in./sec.}$$

$$V = 35.8 \text{ ft./sec.}$$

9.6 Load Diagram - The load diagram in the case of the 5th percentile man, is presented in Figure 49.

9.7 Energy Absorbed in Impact, 95th Percentile Man in Seat - The trajectory of motion is shown in Figure 50. Figure 51 is a diagram of the change in reaction force versus the deformation path.

9.8 The change of forces P_1 , P_2 and P_3 versus the deformation path is shown in Figure 51. From this diagram, the total energy absorption by the Trussgrid blocks and honeycomb structure of the seat base may be calculated.

The forces of P_1 , P_2 and P_3 change quite evidently at the start of attenuation, but due to the fact that the Trussgrid blocks will be totally engaged a moment later, the forces stabilize themselves at an average value.

9.9 The actual energy absorbed differs from the total energy absorbed by a vertical movement more slightly than in the case of the 5th percentile man (section 9.4), due to early total engagement of Trussgrid blocks.

The actual energy absorbed by a vertical movement is

$$E_{t_2} = 7850 \times 7.2 = 56,500 \text{ lb./in.}$$

BLANK PAGE

Load Diagram, 5th Percentile Man

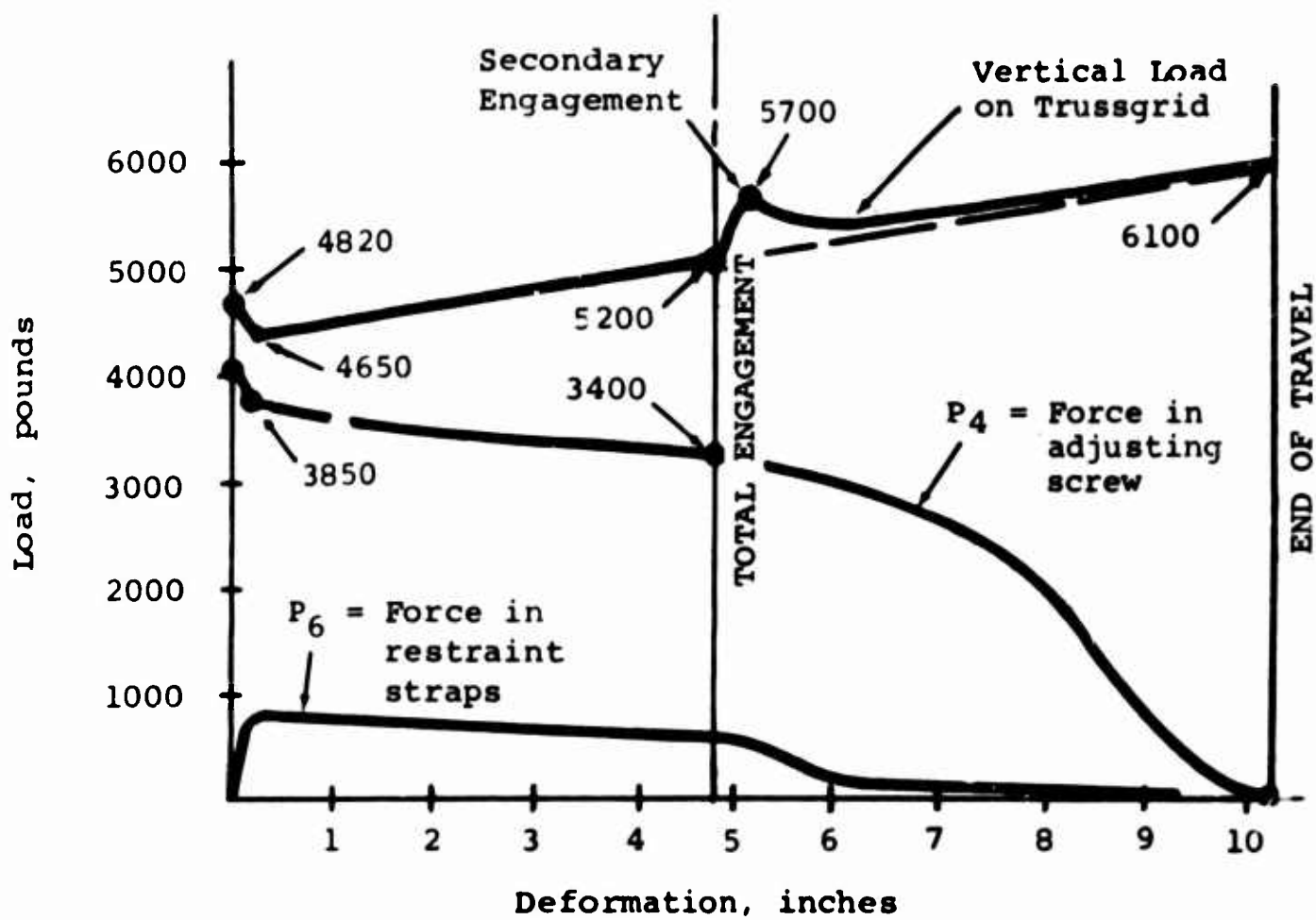

FIGURE 49

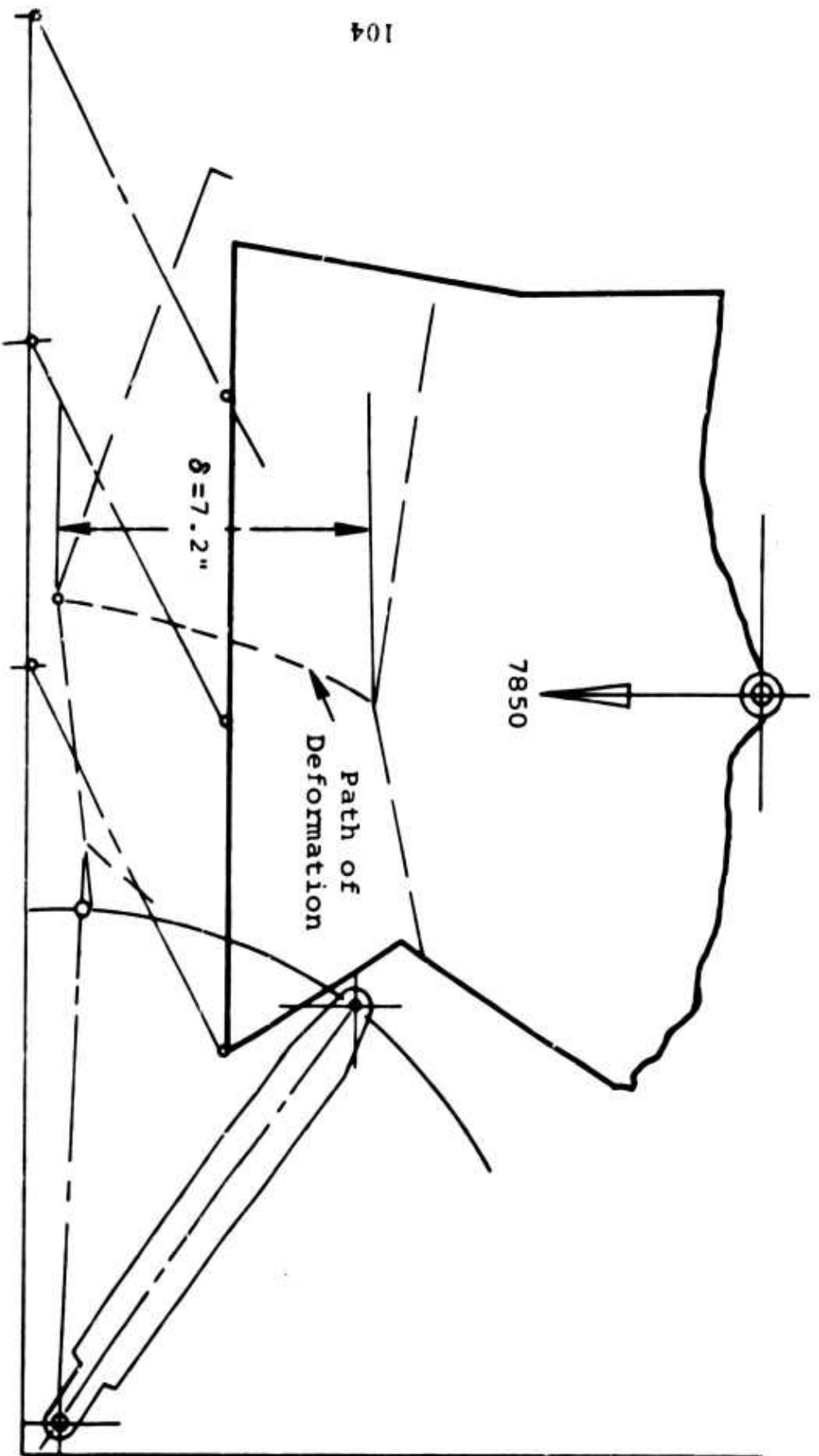

FIGURE 50

Force in Block vs Deformation

95th Percentile Man

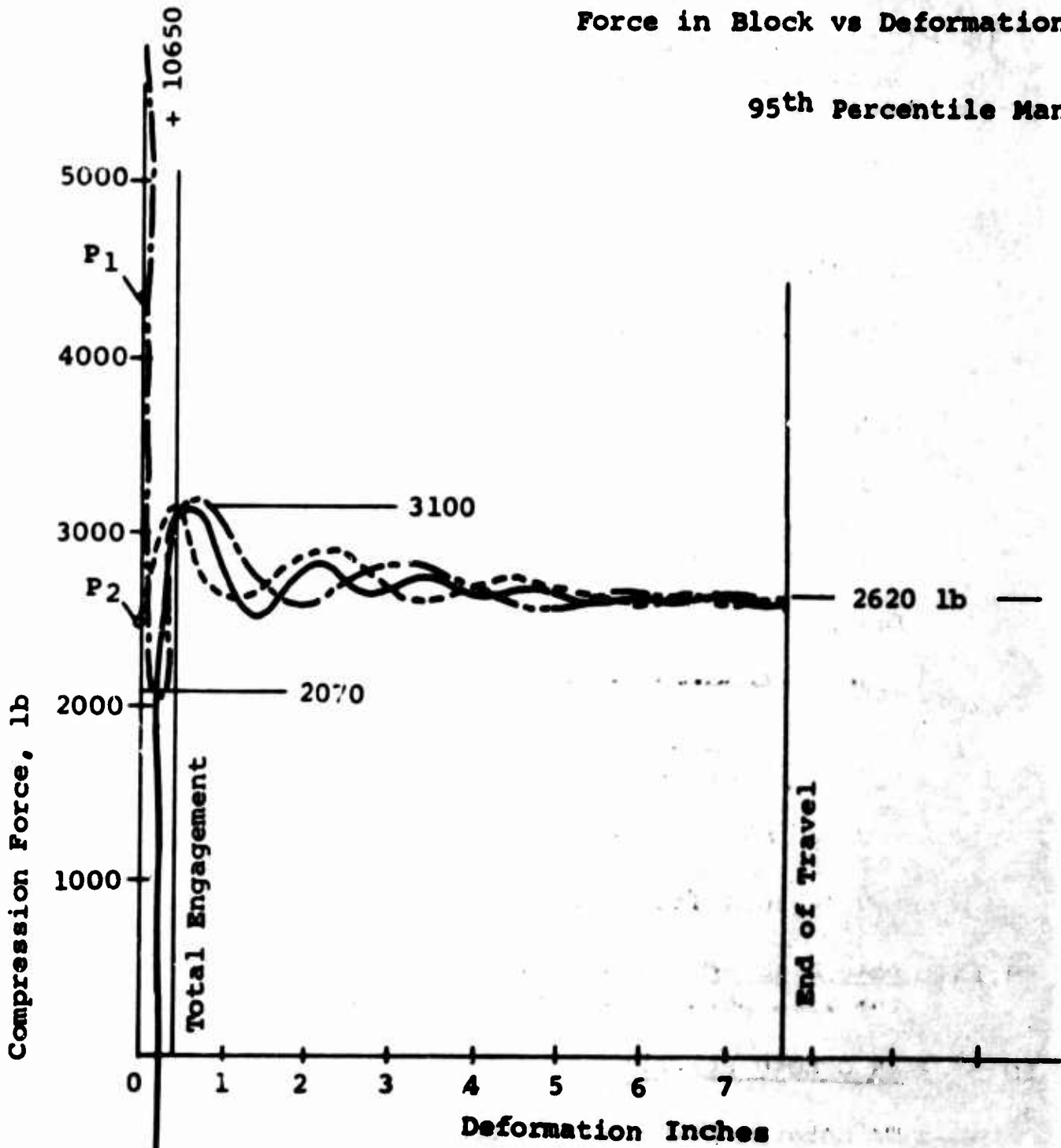

FIGURE 51

- 9.10 Calculation of the Average Sink Speed During Impact, G Load Constant - The total energy of vertical motion,

$$E_{t_z} = 56,500 = Wh + 1/2mV^2$$

Therefore,

$$v^2 = \frac{(56,500 - Wh)^2}{W/g}$$

Where

$$W = 314 \text{ pounds}$$

$$g = 32.3 \text{ ft./sec.}^2 \text{ or } 386 \text{ in./sec.}^2$$

$$h = 7.2 \text{ inches (vertical travel)}$$

Thus,

$$v^2 = \frac{54,240 \times 2 \times 386}{314}$$

$$v = \sqrt{133,000}$$

$$v = 365 \text{ in./sec.}$$

$$v = 30.4 \text{ ft./sec.}$$

- 9.11 Load Diagram - The load diagram, in the case of the 95th percentile man, is shown in Figure 52.

10 45 G LOAD FORWARD

To determine the magnitude and direction of the reactions or inertial load forward, the cases of the 5th percentile man and 95th percentile man will be analyzed separately, due to the entirely different

Load Diagram, 95th Percentile Man

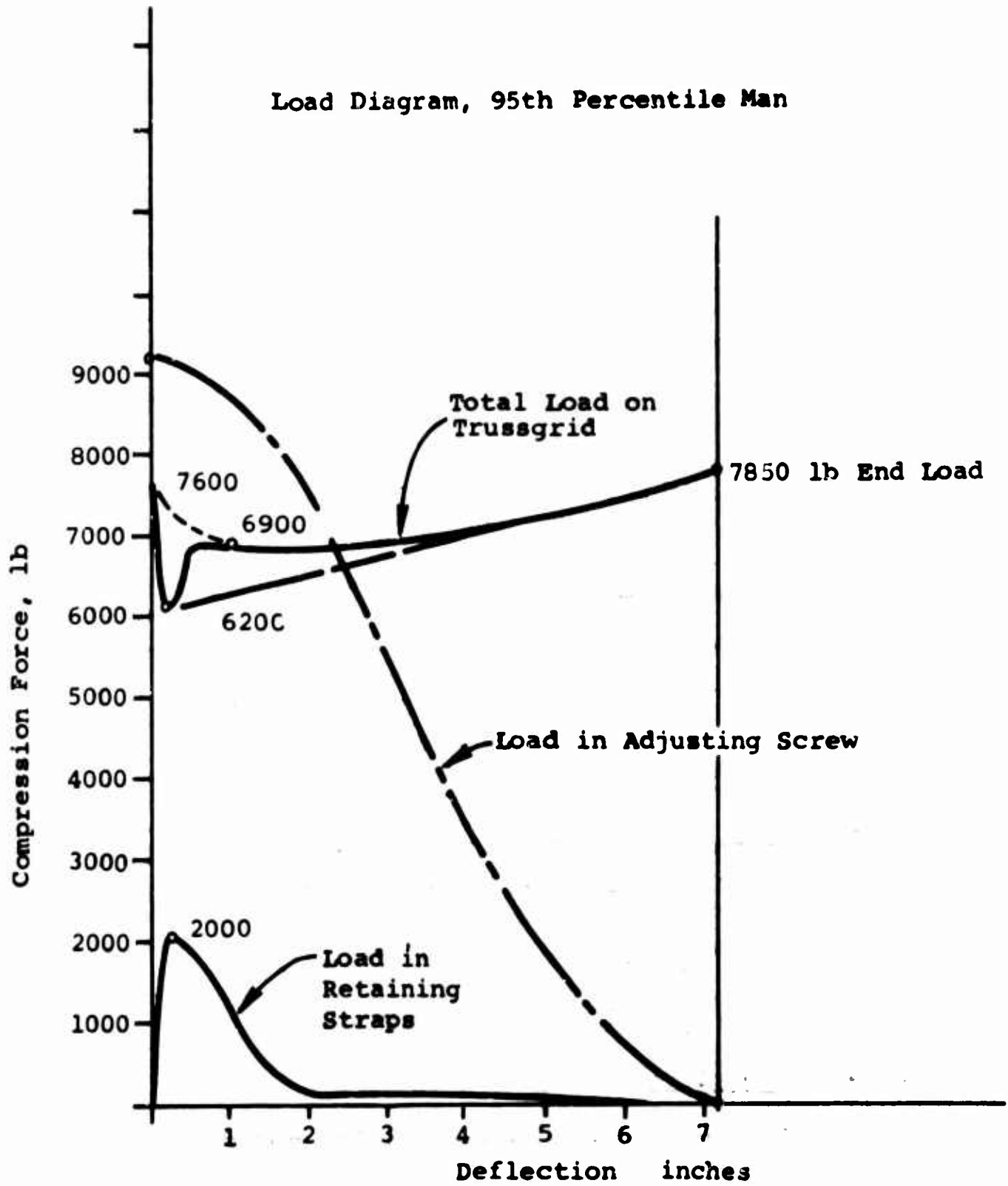

FIGURE 52

geometry that exists for each case.

- 10.1 The 5th Percentile Man - The weights differ in this case from in section 8.1 and must be calculated per section 3.5. A total weight must be applied, since the weight of the seat occupant's legs and boots will be assumed by the chair structure at g load forward.

Man's weight (see section 3.5) is 151 pounds, W_m .

Seat weight (see section 3.13) is 88 pounds, W_s .

Frontal armor plate weight (see section 3.14) is 26 pounds, W_p .

- 10.2 Assumptions - All assumptions stated in section 7.2 are valid except for assumption c, which becomes:

c. The inertial reel engages the restraint straps immediately thus creating a force P_6 .

- 10.3 The Loads at 45 G (Forward) -

$$W_m = 151 \times 45 = 6800 \text{ pounds}$$

$$W_s = 88 \times 45 = 3960 \text{ pounds}$$

$$W_p = 26 \times 45 = 1170 \text{ pounds}$$

- 10.4 Resulting Force -

$$R = W_m + W_s + W_p = 11,930 \text{ pounds}$$

10.5 Only the location of the resulting force axis is required.

$$R_z = 6800(19.5 + 1.50) + 3960(16.65 + 1.50) + 1170(25.48 + 1.50)$$

$$z = \frac{143,000 + 71,800 + 31,600}{11,930} = 20.62 \text{ inches}$$

10.6 The system is statically determinate, since the chair can only move parallel to its original position, due to the immediate engagement of the restraint straps. Due to

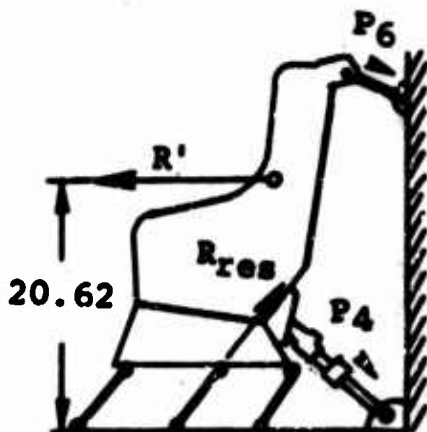

some translations at the Trussgrid blocks pivot points, the same forces will be generated. Thus, they can be exchanged by one strut in the middle. Figure 20 can be used as a source of required dimensional data.

The force P_6 (restraint strap force) is assumed to act oppositely to R . Likewise, the R_{res} of the Trussgrid blocks. Direction of the force P_4 in the adjusting screw jack is not as obvious. This force

is accepted to act oppositely to R (the sign of the result is significant here).

10.7 Calculations -

$$\Sigma X = 0$$

$$+ 11930 - R_{res} \sin 30 - P_4 \sin 51.1 - P_6 \sin 55.7 = 0 \quad (1)$$

$$\Sigma Z = 0$$

$$0 + R_{res} \cos 30 - P_4 \cos 51.1 - P_6 \cos 55.7 = 0 \quad (2)$$

$$-11930 \times 9.15 + R_{res} \times 3.9 + P_6 \times 25.72 = 0 \quad (3)$$

From eq. (1),

$$-R_{res} = - \frac{11930}{\sin 30} + P_4 \frac{\sin 51.1}{\sin 30} + P_6 \frac{\sin 55.7}{\sin 30}$$

$$R_{res} = + \frac{11930}{0.5} - P_4 \frac{0.778}{0.5} - P_6 \frac{0.826}{0.5}$$

$$R_{res} = 23860 - 1.56 P_4 - 1.852 P_6 \quad (4)$$

From eq. (2),

$$R_{res} = P_4 \frac{\cos 51.1}{\cos 30} + P_6 \frac{\cos 55.7}{\cos 30}$$

$$R_{res} = + 0.725 P_4 + 0.651 P_6 \quad (5)$$

From eq. (3),

$$R_{res} \times 3.9 = 11930 \times 9.15 - P_6 \cdot 25.62$$

$$R_{res} = \frac{11930 \times 9.15}{3.9} - \frac{25.62}{3.9} P_6$$

$$R_{res} = 28,000 - 6.62 P_6 \quad (6)$$

Combining eqs. (4) and (5),

$$0.725 P_4 + 0.657 P_6 = 23860 - 156 P_4 - 1.852 P_6$$

$$P_4 = \frac{23860}{2285} - \frac{2507}{2285} P_6 \quad (7)$$

Combining eqs. (4) and (6),

$$28,000 - 6.62 P_6 = 23860 - 1.56 P_4 - 1.852 P_6$$

$$+ 1.56 P_4 = 23860 - 28000 + (6.62 - 1.852) P_6$$

$$P_4 = \frac{4,768}{1.56} P_6 - \frac{4140}{1.56}$$

$$P_4 = 3060 P_6 - 2654 \quad (8)$$

Combining eqs. (7) and (8),

$$10,480 - 1096 P_6 = 3060 P_6 - 2654$$

$$(3060 + 1096) P_6 = 10480 + 2654$$

$$4.156 P_6 = 13134$$

$$P_6 = \frac{13134}{4.156} = 3160 \text{ pounds} \quad (9)$$

$$P_4 = 3.06 \times 3160 - 2654 = 9660 - 2654 = 7000 \quad (10)$$

The direction for P_4 , shown in Figure 53 is selected correctly; it represents tension in the adjusting screw jack.

$$R_{res} = 0.725 \times 7000 + 0.651 \times 3160 = \\ 5070 + 2058$$

$$R_{res} = 7128 \text{ pounds} \quad (11)$$

10.8 The Loads on the Trussgrid Blocks - The total force on the block is

$$R_{res} = 7128$$

The load for one block (pair sidewise)

$$P_1 = P_2 = P_3 = \frac{7128}{3} = 2380 \text{ pounds}$$

The Trussgrid blocks will begin to crush at the start of impact. This crushing will continue until the chair bottoms itself. Motion of the chair will remain fairly parallel to the original chair position, since the restraint strap and adjusting screw jack will be engaged.

10.9 The 95th Percentile Man - According to the considerations expressed in section 10.1,

Man's weight (see section 3.5) = 220 pounds, W_m .

Seat weight (see section 3.13) = 88 pounds, W_s .

Frontal armor plate weight (see section 3.14) = 26 pounds, W_p .

10.10 Assumptions - The assumptions stated in section 10.2 apply here.

10.11 The Loads at 45G (Forward) -

$$W_m = 220 \times 45 = 9900 \text{ pounds}$$

$$W_s = 88 \times 45 = 3960 \text{ pounds}$$

$$W_p = 26 \times 45 = 1170 \text{ pounds.}$$

10.12 Resulting Force -

$$R = W_m + W_s + W_p = 15,030 \text{ pounds}$$

10.13 Only the Z coordinate of the resulting force is required.

$$R_z = 9900(19.5 - 2.33) + 3960(16.65 - 2.33) + 1170(25.48 - 2.33)$$

$$z = \frac{170,000 + 56,600 + 27,100}{15,030} = 16.83 \text{ inches}$$

10.14 The system is statically determinate as far as the considerations expressed in section 10.6 are valid.

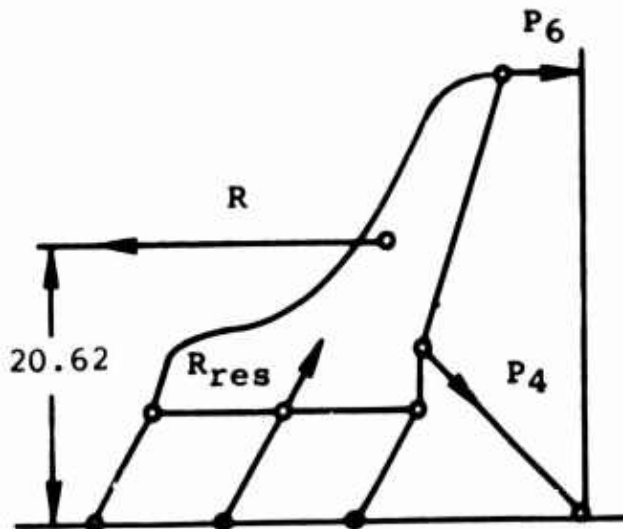

FIGURE 53

Figure 53 may be used to illustrate the system, with the exception that the ordinate of the resulting force R is now 16.83 inches. The direction of the forces is considered to be similar to that expressed in section 10.6. Additional dimensional data are derived from Figure 16. The resultant force, R_{res} , according to section 8.22 goes through the middle strut (2).

10.15 Calculations - The above simplification permits direct calculation of force P_6 .

$$\begin{aligned}\Sigma M_4 &= 0 \\ -15,030 \times 9.16 + P_6 \times 27.04 &= 0 \\ P_6 &= \frac{138,000}{27.04} = 5100 \text{ pounds}\end{aligned}$$

and

$$\begin{aligned}X &= 0 \\ +15,030 - P_6 \sin 78.7 - X &= 0 \\ \Sigma X &= 15,030 - 5100 \times 0.981 = 10,030 \text{ pounds}\end{aligned}$$

and

$$\begin{aligned}\Sigma Z &= 0 \\ 0 - P_6 \cos 78.7 - Z &= 0 \\ Z &= -5100 \times 0.1959 = -1000 \text{ pounds}\end{aligned}$$

The sign was incorrectly selected for Z; actually the force Z is upward

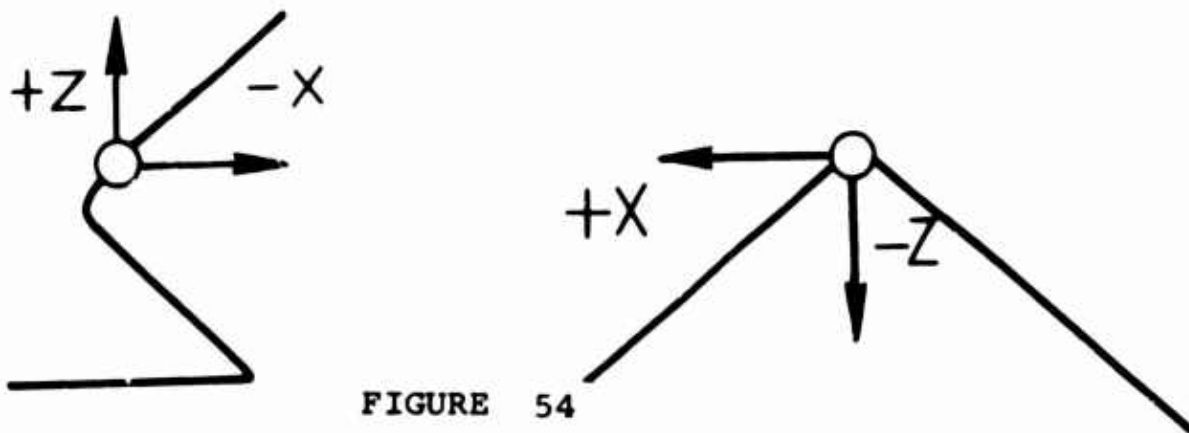

FIGURE 54

On struts (2) and (4), the forces will oppose one another. Resolving the resultant = $\bar{Z} + \bar{X}$ on struts (2) and (4),

in strut (4) (adjusting screw jack), $P_4 = 4000$ pound tension

in strut (2), $R_{res} = 7500$ pounds

10.16 The load on one Trussgrid block (pair sidewise) is

$$P_1 = P_2 = P_3 = \frac{7500}{3} = 2500 \text{ pounds}$$

The blocks are crushed at the instant the impact force 45 g forward applies, but just after motion forward, the g force abruptly diminishes, and the blocks are not completely crushed.

11 45 G LOAD SIDEWISE (see Figure 55)

Considering the motions of the chair under load sidewise, within proportional limits, the adjusting screw jack and restraint strap do not contribute appreciably to the resisting forces. Therefore, the Trussgrid blocks are the only bodies which act to retain the structural integrity of the entire structure in case of side loading. The reactions which could occur in the adjusting screw jack and restraint straps, occur only under the condition that the Trussgrid blocks will be partly or completely sheared under this load.

The Trussgrid blocks' fiberglass skin, being epoxy glued to the honeycomb, greatly increases the rigidity of the blocks in side loading. It is necessary to determine those conditions which

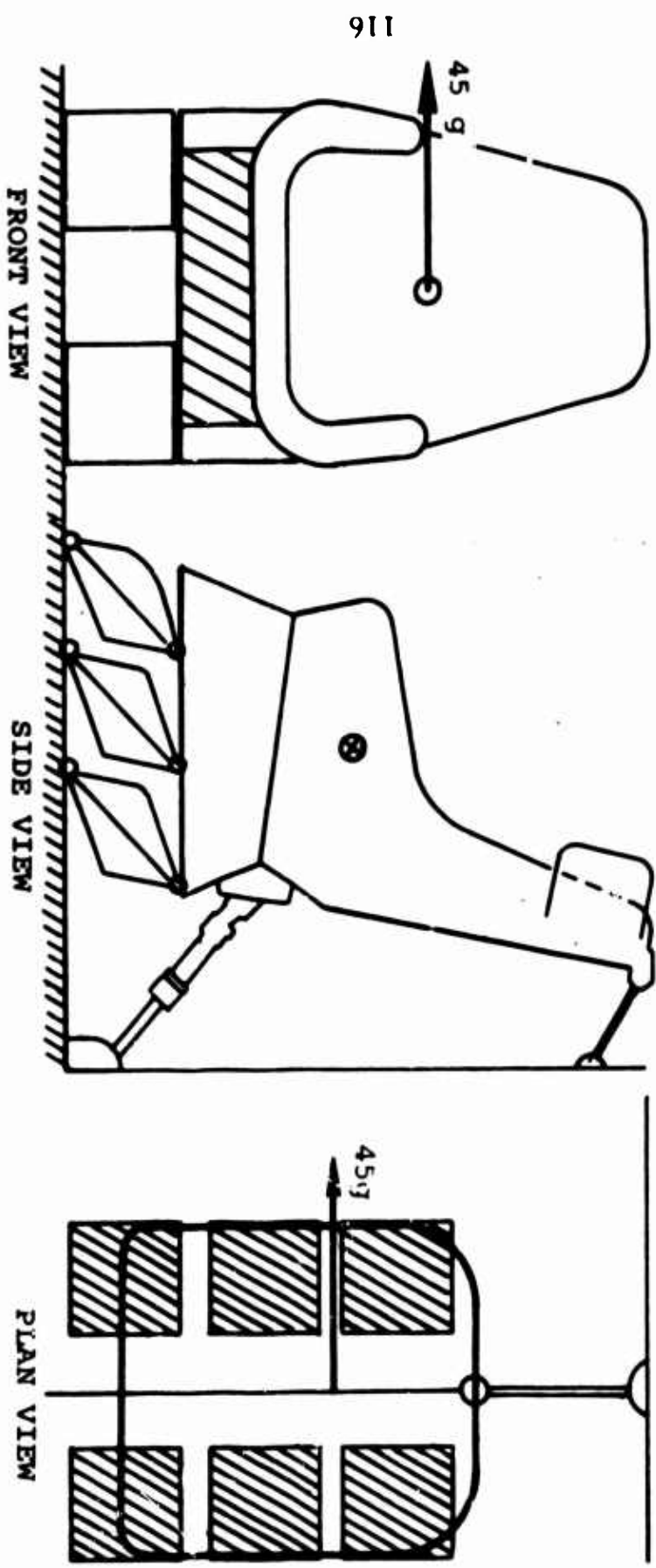

FIGURE 55

will permit the Trussgrid blocks to retain the structural integrity of the entire chair. In the following sections, the loads for the cases of the 5th percentile man and 95th percentile man are analyzed and compared.

11.1 The 5th Percentile Man - The weights included in section 10.1 are accepted here.

11.2 Assumptions -

- a. The base and seat are regarded as a rigid body.
- b. The Trussgrid blocks react to the side load as a rigid structure, with the skin reacting according to the Wagnerian stressed skin principle.
- c. The forces on the restraint straps are neglected within the small deformation of the Trussgrid blocks.
- d. The forces acting on the adjusting screw jack are neglected within small deformation of the Trussgrid blocks.
- e. The seat is in the up position.

11.3 The Loads at +45 G (Sidewise) -

$$W_m = 151 \times 45 = 6800 \text{ pounds}$$

$$W_s = 88 \times 45 = 3960 \text{ pounds}$$

$$W_p = 26 \times 45 = 1170 \text{ pounds}$$

11.4 Resulting Force -

$$R = W_m + W_s + W_p = 11,930 \text{ pounds}$$

11.5 The Location of the Resulting Force -

Axis X:

$$6800(20.2 + 2.00) + 3960(15.44 + 2.00) + 1170$$

$$(18.53 + 2.00) = R_x$$

$$x = \frac{151,000 + 69,000 + 24,060}{11,930} = 20.4$$

Axis Z:

$$z = 20.62$$

11.6 From Figure 20, it is seen that the inertial side force comes very close to the hinge line of the central pair of Trussgrid blocks. For simplicity of calculation, the side force is assumed to be applied exactly at the hinge line of the central blocks (see Figure 56).

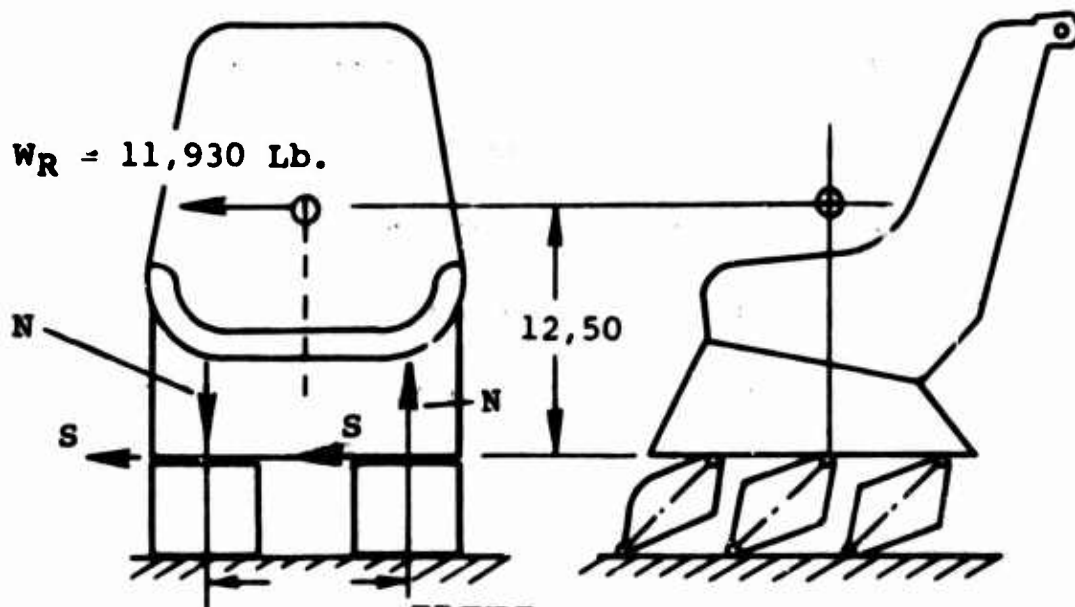

Resolving the side force on the hinge plane of the Trussgrid blocks, it is seen that the shear force, S , acting parallel to floor is

$$S = 11930 \text{ pounds}$$

Moment $M = 11930 \times 12.50 = 149,000 \text{ lb./in.}$, which produces forces N on the blocks.

$$N = \frac{149,000}{12.2} = 12,200 \text{ pounds}$$

A reasonable assumption is that within the elastic deformation of the Trussgrid blocks, the forces N and S do not interfere. (The Trussgrid blocks resistance to normal forces N do not change appreciably due to shear and vice versa.) Thus the shear force, S , is equal in all six Trussgrid blocks.

Then,

$$S_1 = \frac{S}{6} = \frac{11930}{6} = 1980 \text{ pounds}$$

And

$$N_1 = \frac{12200}{3} = 4070 \text{ pounds}$$

The compression force T in the block (see Figure 57)

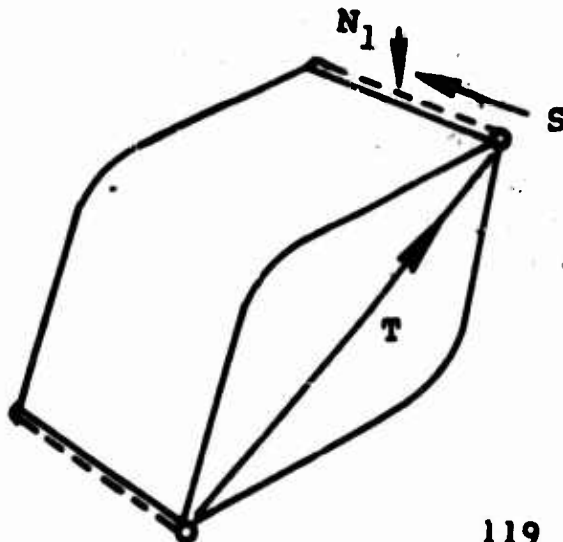

FIGURE 57

will be

$$T = \frac{N}{\cos 30} = \frac{4070}{0.866} = 4600 \text{ pounds.}$$

The Trussgrid blocks will be unable to withstand so great a force in compression, since they are designed for an 1000-pound compression force only. Calculation indicates however that the Trussgrid block in tension could withstand such a load. This circumstance will determine the behavior of the chair an instant after the side impact. The chair will immediately crush the blocks on the side at which the impact force is directed, and while leaning toward that side and engaging the restraint strap will create a force P_6 in the strap. The adjusting screw jack

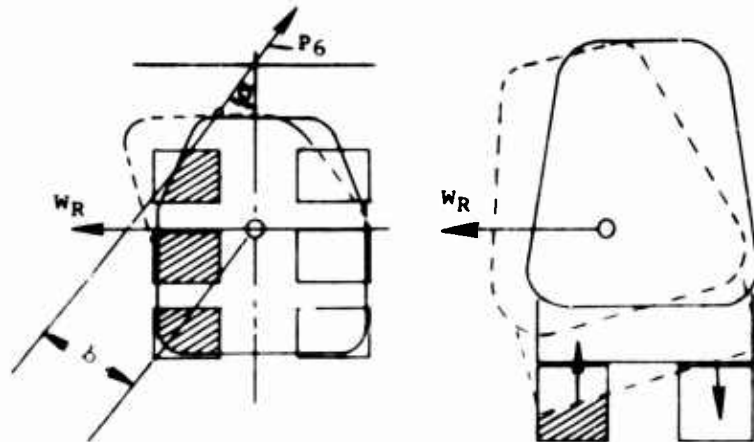

FIGURE 58

will probably be engaged in this 3-dimensional motion, further complicating the situation. However, examining the front-view drawing in Figure 58, it may be concluded that the chair will rotate around a point very close to the anchor point of the adjusting screw jack. Thus, it is a logical assumption to ignore the effect of the adjusting screw jack.

The force P_6 is transferred the distance b to line $a-a$. For the first approximation the effect of the moment $P_6 \times b$ on the structure is neglected. Considering the chair as a rigid body, Figure 59 is derived.

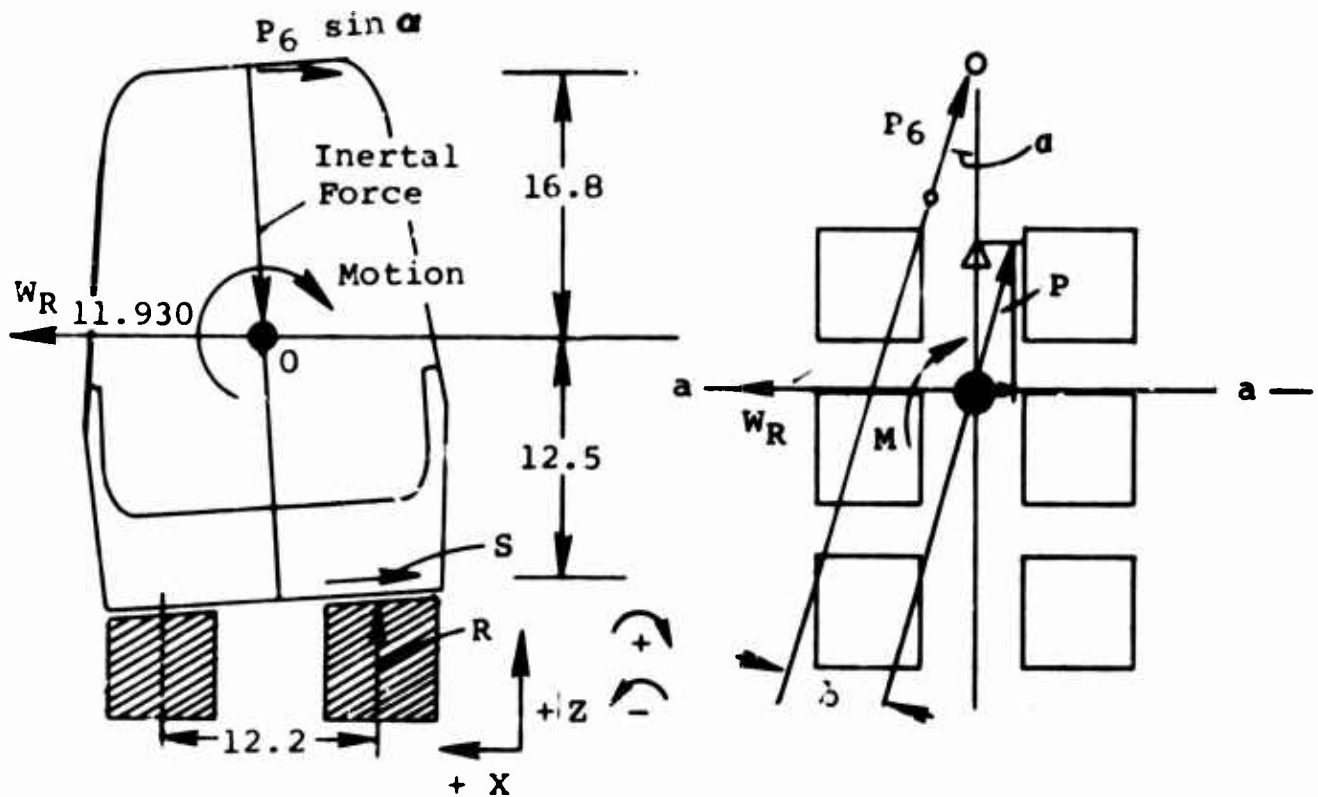

FIGURE 59

It is assumed that the blocks crushed on the side of compression will create a constant force acting upon the chair upward and equal to the crushing strength on the three Trussgrid blocks.

$$T_{cr} = 1100 \text{ pounds per one block (Section 8.9)}$$

$$R = 3T_{cr} = 3300 \text{ pounds}$$

The behavior of the chair will be as follows: In the first moment of impact, the chair will immediately crush three blocks on one side, but due to

its leaning toward the same side, the restraint strap will be engaged and will pull the chair backwards, compressing the blocks on the other side of the chair. Since the crushing force on the blocks is known, the shear stress and component of the restraint strap force P_6 may be determined.

$$\sum X = 0$$

$$11930 - P_6 \sin \alpha - S = 0$$

$$\sum M_O = 0$$

$$+P_6 \sin \alpha \cdot 16.8 - R \cdot 6.1 - S \cdot 12.5 = 0$$

$$S = 11930 - P_6 \sin \alpha$$

$$S = \frac{P_6 \sin \alpha \cdot 16.8 - 3300 \cdot 6.1}{12.5}$$

and,

$$11930 - P_6 \sin \alpha = 1.4 P_6 \sin \alpha - 1600$$

$$1.4 P_6 \sin \alpha + P_6 \sin \alpha = 11930 - 1600$$

$$P_6 \sin \alpha = \frac{10330}{2.4} = 4300 \text{ pounds}$$

and,

$$S = 11930 - 4300 = 7630$$

The area of these blocks are $6 \times 4 \times 3 = 72$ square inches.

According to test data published by General Grid Corp., Army Chemical Center, Maryland, the shear strength of the Trussgrid structure is approximately 130 psi for a density used in the case of the subject Trussgrid blocks (3.2 pounds per cubic foot). This shear strength will be reinforced by the fiberglass plate facing. The exact strength of the Trussgrid blocks designed for the armor seat can be determined only by test. Therefore, the following calculations of shear strength serve only as an approximation.

Assuming that the fiberglass facing preserves its flat form by being glued to the Trussgrid core

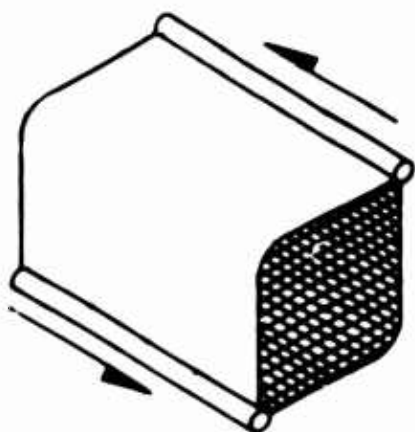
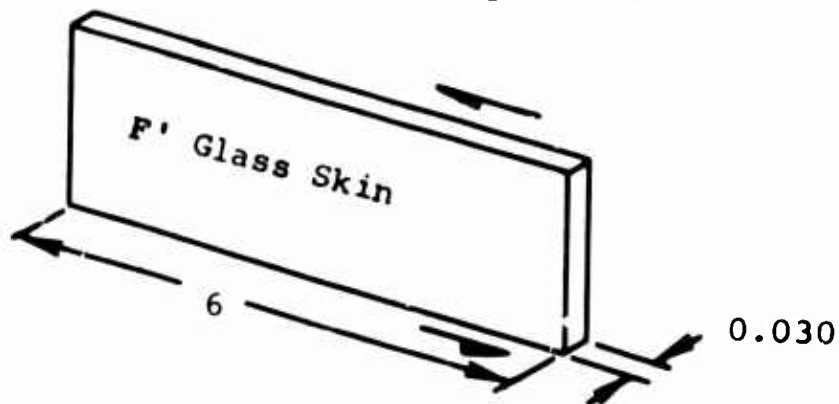

FIGURE 60

(see Figure 60), the maximum shear strength of the panel may be calculated.

The shear area is

$$A = 6 \times 0.030 = 0.18 \text{ square inches.}$$



Assuming a shear strength of 20,000 psi for fiber-glass laminate, the maximum load that can be carried is

$$p = 20,000 \times 0.18 = 3600 \text{ pounds.}$$

For both sides of the Trussgrid blocks, the load will be

$$P = 7000 \text{ pounds.}$$

The Trussgrid itself is able to carry

$$6 \times 3 \times 130 = 2300 \text{ pounds}$$

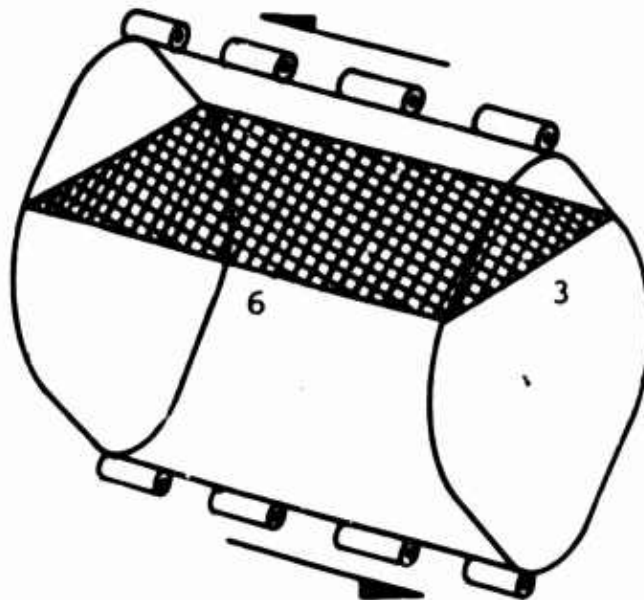

Therefore, the total maximum shear load that a Trussgrid block can sustain is

$$S = 7000 + 2300 = 9300 \text{ pounds.}$$

Therefore, the capacity of three blocks is approximately

$$S_t = 25,000 \text{ pounds}$$

(Reduction of the S_t is due to unequal loading).

The maximum shear force possible to occur is 11,930 pounds. Therefore, the blocks will not be sheared. The longitudinal component of force P_6 ($P_6 \cos \alpha$) will not affect the envisioned arrangement, since the adjusting screw jack can absorb the compression load.

The moment of force P_6 on the arm b (Figure 59) will affect the scheme of forces very little due to the Trussgrid block's large shear capacity.

At $\alpha = 30^\circ$,

$$P_6 = \frac{4300}{0.5} = 8600 \text{ pounds}$$

$$M = 8600 \times 10 = 86,000 \text{ lb-in.}$$

$$M_1 = \frac{M}{6} = \frac{86000}{6} = 14,300 \text{ lb-in.}$$

The average radius is 15 inches. The shear force on each block is

$$S_1 = \frac{14300}{15} = 950 \text{ pounds}$$

The shear capacity of one block is approximately 9000 pounds. The effect of moment $P_6 \times b$ is insignificant.

- 11.7 The case with the 95th percentile man as occupant of the seat at 45g side load does not change considerably the loads on the elements of the structure, due to the fact that the height of the chair base from the floor has no significance on loads on the blocks. The angle of the Trussgrid blocks to the floor line has no significance either, since the blocks are nearly in a condition of total engagement in the chairs position of lowest adjustment.

SUMMARY OF DESIGN LOADS ON TRUSSGRID BLOCKS

Figures 61, 62, and 63 summarize the design loads at the beginning of attenuation, at the instant prior to total engagement of the Trussgrid blocks, and at total engagement.

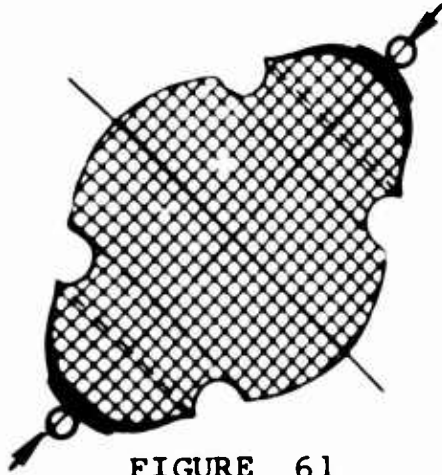

FIGURE 61

Block Intact

$$P_{lim} = 1000 \text{ pounds}$$

$$P_{ult} = 1050 \text{ to } 1100 \text{ pounds}$$

$$P_{destr} = 1160 \text{ pounds}$$

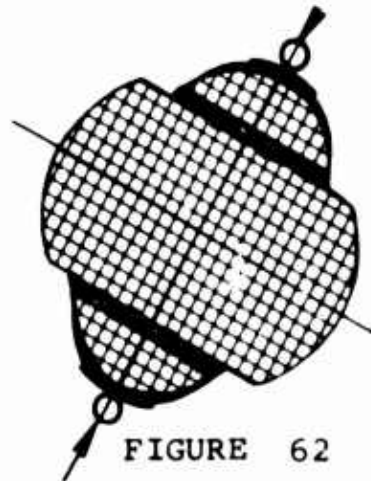

FIGURE 62

Instant Before Total Engagement

$$P_{destr} = 960 \text{ pounds}$$

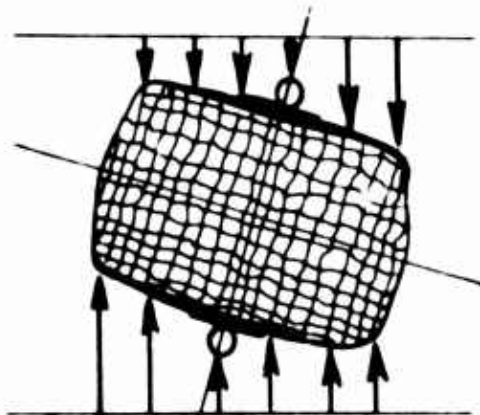

FIGURE 63

Total Engagement

$$P_{destr} = 1035 \text{ pounds}$$

SELECTION OF TRUSSGRID BLOCK DATA

From sections 8.14 and 8.27, the following crushing loads are noted:

For the 5th percentile man, 6100 pounds

For the 95th percentile man, 7850 pounds

It is evident that the selection of density of the Trussgrid must be in accordance with the load occupied by deceleration of the 5th percentile man. If the crushing strength of the Trussgrid blocks is selected according to loads generated by the 95th percentile man, the blocks might not get crushed in the case of the 5th percentile man, causing unacceptable peaks in the g load.

13.1 The crushing load in the flat position is

$P = 6100$ pounds, per square inch of area

$A = 18 \times 6 \times 2 = 216$ square inches

$$p = \frac{6100}{216} = 28 \text{ psi}$$

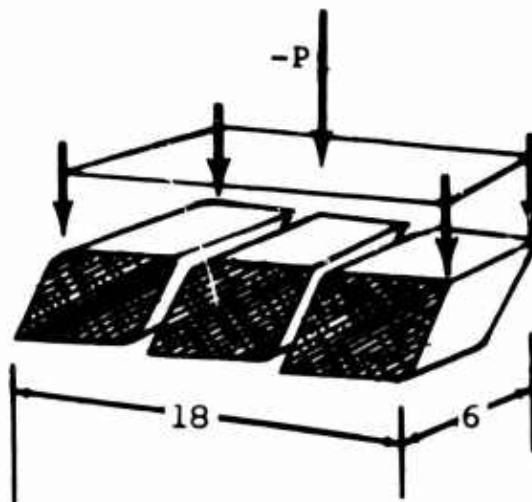

FIGURE 64

13.2 According to data from General Grid Corporation, accepting bare core data,

Density = 2.3 pounds per cubic foot

13.3 According to additional General Grid Corporation specifications, the following Trussgrid core data apply in the case of the subject chair:

Density = 2.3 lb/cu.ft. - Aluminum Alloy
5052, H-39 cond.

Foil Thickness = 0.0015 inch; corrugation
height = 3/16 inch

Company designation is Trussgrid - 3/16 -
0.0015(5052) - 2.3

13.4 Stress Analysis of the Trussgrid Block - The fastening of the hinge must be calculated for worst-case conditions, tension force in the 45g case applied sidewise.

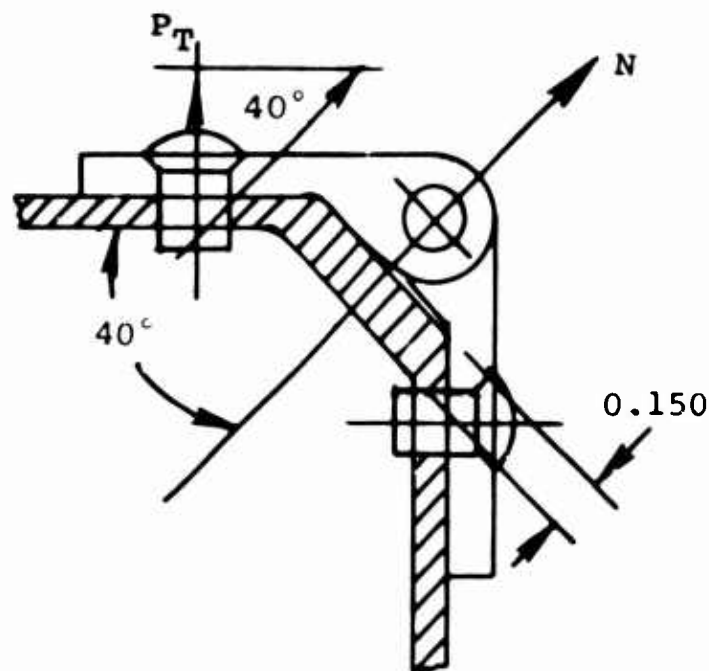

FIGURE 65

According to section 11.6,

$$N = 12,200 \text{ pounds on one side of the chair}$$

The load on each block will be

$$N_1 = \frac{12,200}{3} = 4070 \text{ pounds.}$$

This load must be increased, due to the possibility of uneven loading.

Thus,

$$N_1' = 1.2 \times 4070 \approx 5000 \text{ pounds}$$

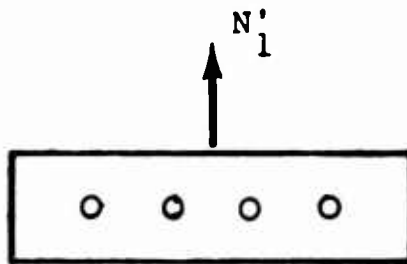

FIGURE 66

Since there are 7 fastening points, the load per each point is

$$P = \frac{N_1'}{7} = \frac{5000}{7} \approx 700 \text{ pounds}$$

From Figure 52, the force pulling the screw from the fiberglass plate is

$$P_N = P \sin 40 = 700 \times 0.643 = 450 \text{ pounds.}$$

The allowable load is obtained from

$$P_N = S_s \frac{\pi d}{1.5} t$$

where

P_N = allowable load

t = 0.150 inch

S_s = allowable shear stress for fiber-glass $\approx 10,000$ psi min.

1.5 = safety factor

d = outside diameter of screw thread

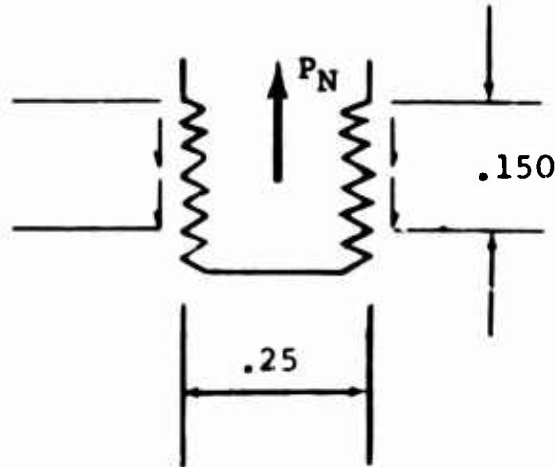

FIGURE 67

$$P_N = \frac{(10,000)(\pi)(.250)(.150)}{1.5} = 790 \text{ lb}$$

$$\text{M.S.} = \frac{790}{450} - 1 = .75$$

The calculation of bearing stresses in the aluminum hinge,

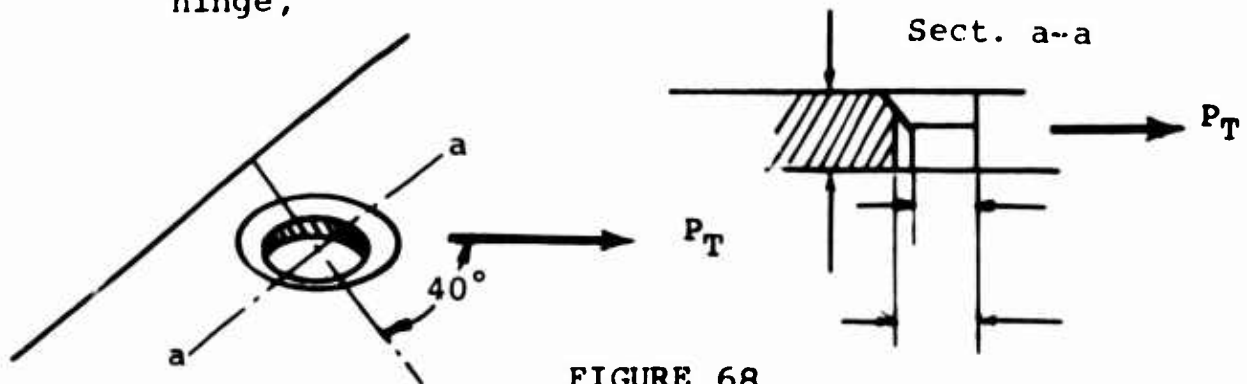

FIGURE 68

Section A-A Ultimate Bearing Analysis

From Figure 65,

$$P_T = P \cos 40 = 700 \times 0.766 = 540 \text{ pounds.}$$

The bearing area

$$A = 2 r \times .060 = 2 \times .140 \times .060$$
$$A = .0168 \text{ square inch}$$

where

$$r = .140 \text{ inch}$$

Therefore,

$$f_{br} = \frac{P_T}{A} = \frac{540}{.0168} = 20,000 \text{ psi}$$

$$F_{bru} = 50,000 \text{ (MIL-HDBK-5 value reduced due to Section A-A proximity to weld)}$$

$$M.S. = \frac{50,000}{32,000} - 1 = .56$$

14 STRESS CALCULATION OF THE SEAT BODY

Analyzing the loads on the seat body, the most severe load case must be considered. The requirement for the seat body will be then to remain intact during all possible load cases and to not be injurious to the occupant under any circumstances.
occupant

14.1 The Case of Maneuver Loads - It is obvious that the loads generated by impact forces are much greater than maneuver loads. Therefore, the stresses occurring during flight g conditions need not be considered.

14.2 The Case of 25G (Down) Loads - The load from the occupant is well distributed on the bucket of the seat and is just as well distributed on the Trussgrid blocks. Thus, the loads taken by the seat itself are negligible. However, forces in the adjusting screw jack

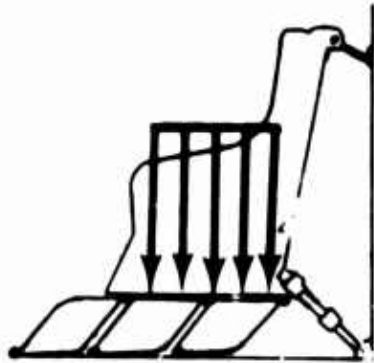

FIGURE 69

are quite high (compression = 9200 pounds in the 95th percentile man case). Therefore, it is necessary to check the anchor point of the adjusting screw jack.

14.3 Calculations - Reference Boeing-Vertol drawings SK13030 and SK13027.

$$P = 9200 \text{ lb}$$

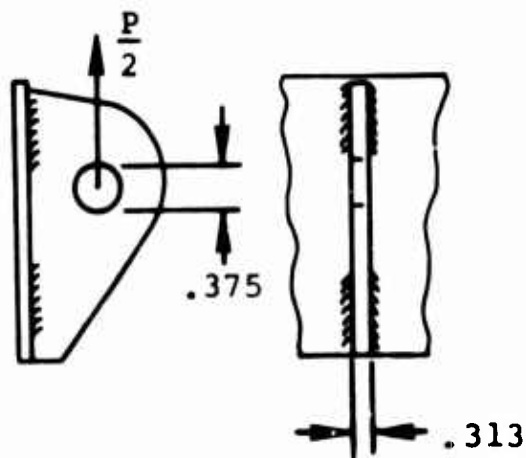

FIGURE 70

Lug Analysis

The limit design load P_D

$$P_D = \frac{1}{1.5} dtF_{bru}$$

$$F_{bru} = 63,000 \text{ psi}$$

$$P_D = \frac{.375 \times .313}{1.5} \times 63,000 = 4910 \text{ pounds.}$$

The load for two lugs

$$P_{D_{total}} = 2 \times 4910 = 9820 \text{ pounds}$$

$$\text{M.S.} = \frac{9820}{9200} - 1 = .07$$

Weldment in shear:

Shear area:

$$A_s = 1.3 \times 2 \times 0.2 + 0.7 \times 2 \times 0.2$$

$$= 0.8 \text{ square inch}$$

$$P = \frac{1}{1.5} A_s \times F_s$$

$$P = \frac{1}{1.5} 0.8 \times 19,000 = 10,000 \text{ pounds}$$

where

$$F_s = 19,000 \text{ psi (weld allowable)}$$

The total ultimate design load

$$2P = 20,000 \text{ pounds}$$

$$\text{M.S.} = \frac{20,000}{9,200} - 1 = 1.15$$

Therefore, lugs have sufficient strength.

To check the buckling stress for the gussets, according to Roark, Formulas for Stress and Strain, Table XVI, Case C; the critical compressive stress,

$$S' = k \frac{E}{1 - \nu^2} \left(\frac{t}{b} \right)^2 \quad a = \frac{S_v}{S_o - S_v}$$

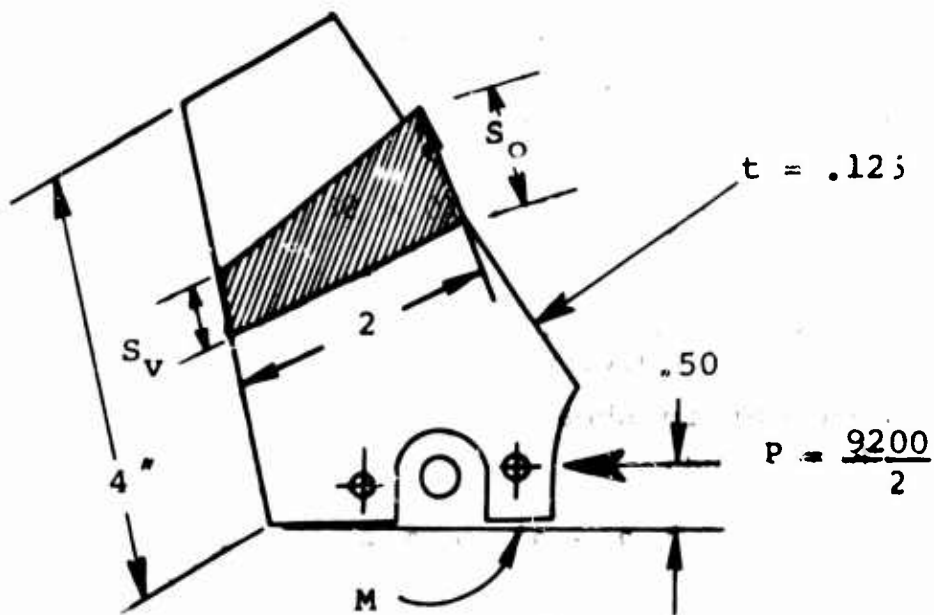

FIGURE 71

$$M = 0.5 \times \frac{9200}{2} = 2300 \text{ lb-in.}$$

Conservatively assume $a = 1.5$

$$a = \frac{3x}{5x - 3x} = 1.5 \quad \frac{a}{b} = \frac{3}{4} = .75$$

$$S_o = 5x \quad S_v = 3x \quad k = 5$$

$$M = \frac{(5x) + (3x)}{2} \cdot .2 \cdot \frac{2t}{3} = \frac{2x}{3}$$

$$x = M \cdot \frac{3}{2}$$

$$S_o = \frac{5M \cdot 3}{2} = 17,000 \text{ psi}$$

$$\begin{aligned} \text{and } S' &= 5 \times \frac{10.5 \times 10^6}{1-.36^2} \times \left(\frac{125}{4}\right)^2 \\ &= 5 \times 12 \times 10^6 \times .00098 = 59,000 \text{ psi} \\ 59,000 \text{ psi} &> 17,000 \text{ psi} \end{aligned}$$

The gussets are safe as far as buckling is concerned.

For the bearing of the frontal armor plate, this joint must withstand the 25g load of the frontal armor plate as well as the head and arms of the seat occupant under crash condition. The failure of this joint could be injurious to the occupant due to the guillotine action of the edges of the frontal plate.

Assuming the weight of the head (with helmet), arms, and part of the shoulders as 35 pounds, the total weight is $P = 26 + 31 = 61$ pounds.

$$\begin{aligned} \text{Load} &= P \times g \\ \text{Load} &= 61 \times 25 \\ \text{Load} &= 1500 \text{ pounds} \end{aligned}$$

Torso Protector

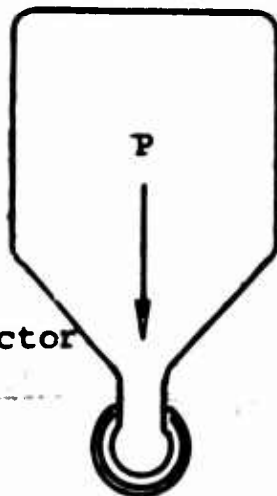

This 1500-pound load, which includes the weight of the frontal armor plate plus a portion of the human weight is distributed over the mounting plate (see Figure 59), which is bolted to the Doron armor plate. The latter rests on the Trussgrid block.

The worst-case condition may be calculated as follows, neglecting the ceramic armor plate and the resistance of the Trussgrid structure. The g force from the armor plate and part of the human weight is regarded as a distributed load on the mounting plate. These approximations are realistic enough, since the ceramic armor plate is extremely fragile in tension.

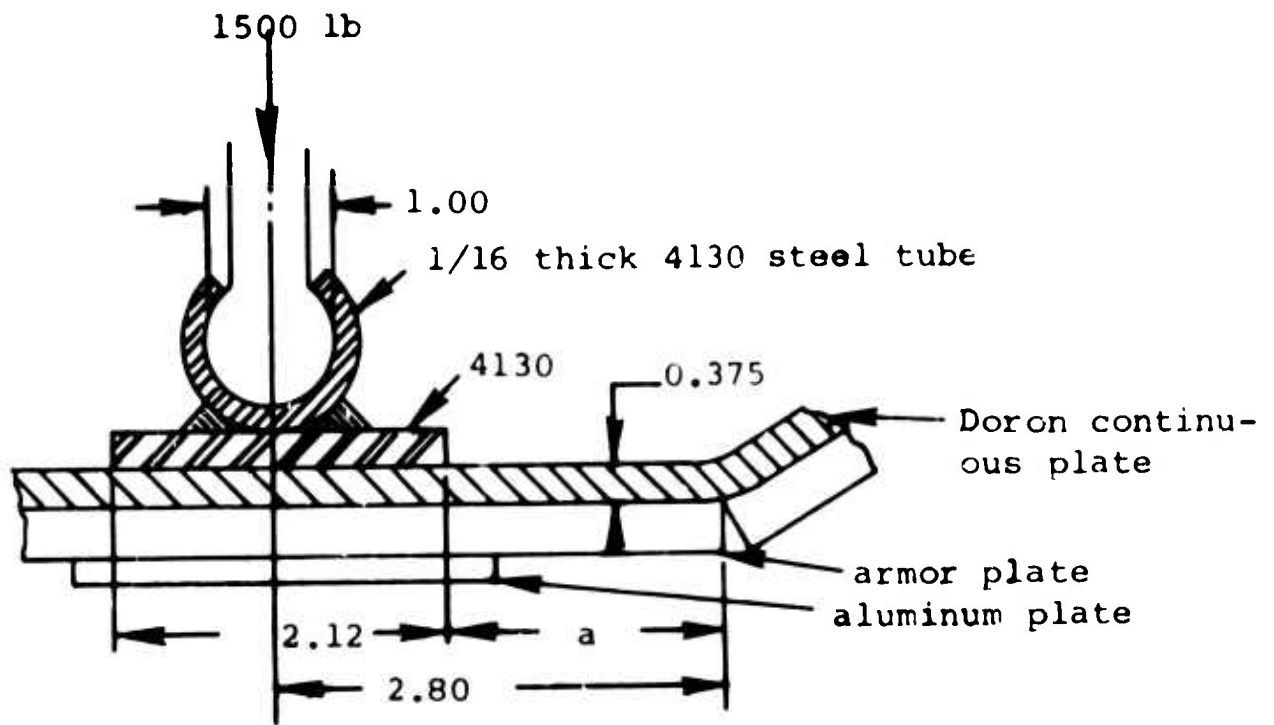

FIGURE 72

Trussgrid deflections are, of course, much greater than any deflection of the Doron plate in limits of elasticity, and the aluminum plate contributes very little if the Doron plate breaks.

Then

$$R_1 = \frac{P \times 10^2}{123} (3 \times 2 + 10)$$

$$R_1 = 0.93 \times 1500 = 1390 \text{ pounds}$$

The maximum bending moment

$$-1500 \times \frac{2 \times 10^2}{12^2} + 1390 \times 2 = -2080 + 2780$$

$$M_{\max} = 700 \text{ lb-in.}$$

Now, accepting a strip of Doron of 2.5 inch width (see Figure 60), the condition worsens considerably, neglecting the diaphragm action of the severed edges which relieves the stresses.

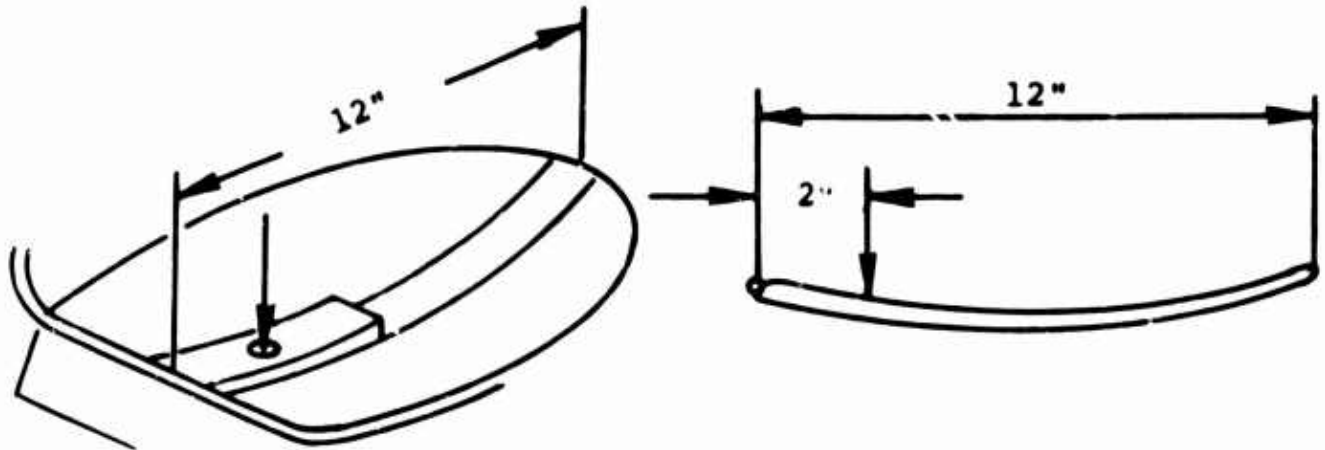

FIGURE 73

The section modulus for this strip will be

$$s = \frac{bh^2}{6} = 2.5 \times \frac{0.375^2}{6} = 0.059$$

and bending stress at that point of the Doron plate supporting the frontal armor plate is

$$f_b = \frac{M}{s} = \frac{700}{0.059} = 11,800 \text{ psi}$$

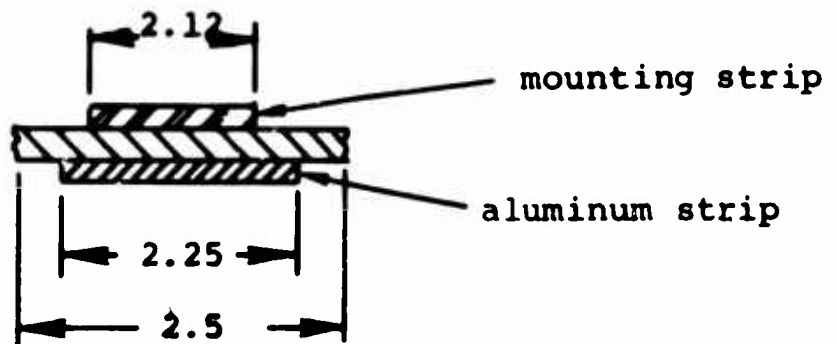

FIGURE 74

Doron stress data:

$$\begin{aligned} E &= 2.97 \times 10^6 \text{ psi} & \text{M.S.} &= \frac{29,190}{11,800} - 1 = 1.45 \\ F_{Tu} &= 73,340 \text{ psi} \\ F_{Cu} &= 18,980 \text{ psi} \\ F_b &= 29,190 \text{ psi} \end{aligned}$$

Therefore, in the worst case (compression), the allowable stress is much higher than the stress which could occur under the 1500 pound load in the structure. Thus, the design is safe for 25g down.

14.4 The Case of 45G (Forward) -

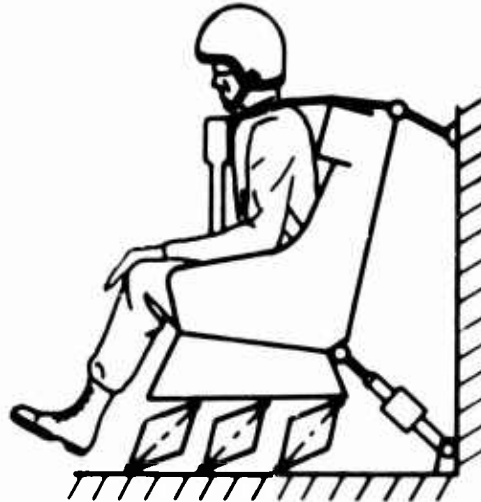

FIGURE 75

The weight of the man and the frontal armor plate forward and is restrained by the shoulder straps which are connected to the bridge at the chair back. The chair itself is restrained by the restraint straps; thus the main forces are acting through the bridge, bypassing the rest of the chair structure.

The frontal armor is restrained by the shoulder straps, but the bottom point is held by slotted pipe, the ends of which are closed by welded plates.

The greater part of the force will be taken by the shoulder straps. The force acting on the bottom pin of the armor plate is approximately 12 percent of the total force applied to the frontal armor plate.

$$\text{Total force} = (200 + 26)45 = 11,000 \text{ lbs}$$

14.5 Calculations -

The 95th Percentile Man - The forces shown in Figure 76 are applied to the chair and occupant as a rigid body. However, to consider forces on the elements of chair following this assumption would be wrong.



FIGURE 76

In this case, the 45g forward internal force, the pilot and frontal armor plate are moving forward independent of the chair and are loading the connecting bridge on the top of the back of the chair, bypassing the rest of the structure. These "internal forces," (considering the pilot and chair as a unit) must be determined in order to obtain the loads on the structure of the chair itself.

Considering Figure below, the internal load of the main weight - the pilot and frontal armor plate - is distributed between the shoulder strap attachment and seat belt which is connected directly to the frame of the seat. According to section 10.11, the internal force of the man in the case of 45g forward force is

$$W_m = 9900 \text{ pounds}$$



The frontal armor plate adds to that $W_p = 1170$ pounds, or

$$P_i = 9900 + 1170 = 11,070 \text{ pounds.}$$

The shoulder straps and seat belt are connected to the solid structure which immediately translates these forces to the restraint strap and adjusting screw jack.

Considering the man and frontal armor plate as a body defined by the points a, b and c, (Figure 77) the following forces acting on the shoulder straps can be determined.

1. The forces acting in the shoulder strap (R_{str})
2. The tension force in the seat belt (R_{belt})
3. The normal force, N , acting upward on the pilot body.

The location of the c.g of the pilot and frontal armor plate is derived from Figure 3, 28, and the following calculation.

$$1170 \times (25.48 - 2.33) + 9900(19.5 - 2.33) = 11070 (Z)$$

$$Z = \frac{27,100 + 170,000}{11,070} = 17.8 \text{ in.}$$

and

$$1170(18.53 - 1.90) + 9900(20.2 - 1.90) = 11070(X)$$

$$X = 19500 + \frac{181,000}{11,070} = 18.1 \text{ in.}$$

Knowing the ordinate of the resultant inertial force, all of the necessary dimensions are obtained from Figure 3 and are included in Figure 77.

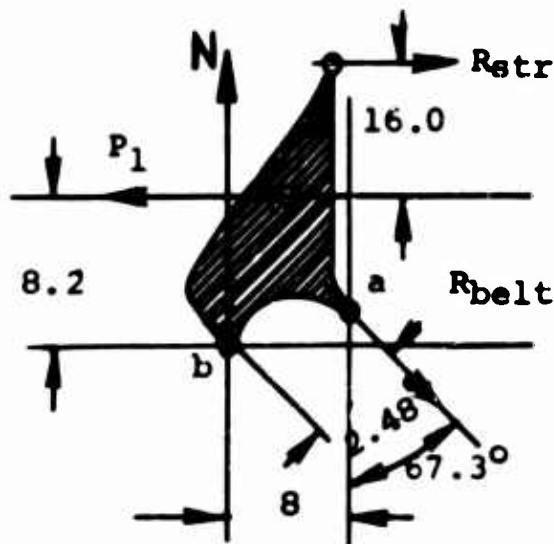

FIGURE 77

Taking point b as the center of the coordinates,

$$\sum X = 0$$

$$R_{str} - P_1 + R_{belt} \sin 67.3 = 0$$

$$\sum Z = 0$$

$$N - R_{belt} \cos 67.3 = 0$$

$$\Sigma M_b = 0$$

$$+R_{\text{belt}} \times 2.48 - P_i \ 8.2 + R_{\text{str}} \ (16.0 + 8.2) = 0$$

$$R_{\text{str}} = P - R_{\text{belt}} \sin 67.3$$

$$R_{\text{str}} = \frac{P_i \ 8.2 - R_{\text{belt}} 2.48}{24.2}$$

and

$$24.2 P_i - 24.2 R_{\text{belt}} \sin 67.3 = P_i \ 8.2 - R_{\text{belt}} \ 2.48$$

$$P_i (24.2 - 8.2) = R_{\text{belt}} (24.2 \sin 67.3 - 2.48)$$

$$R_{\text{belt}} = \frac{16}{19.82} \ 11070 = 8920 \text{ pounds}$$

then,

$$N = 0.386 \times 8920 = 3450 \text{ pounds}$$

and

$$R_{\text{str}} = 11070 - 8920 \times 0.922 = 2870 \text{ pounds}$$

Having determined the forces acting on the chair body from the man's body with the armor, the forces acting on the chair body alone may be determined as shown in Figure 65.

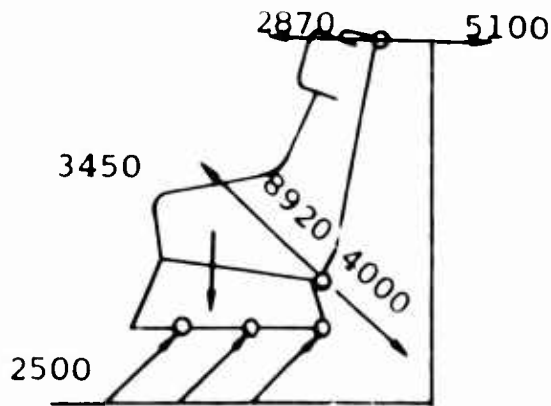

FIGURE 78

Combining these forces, the loads acting on the body of the chair above may be determined (see Figure 79).

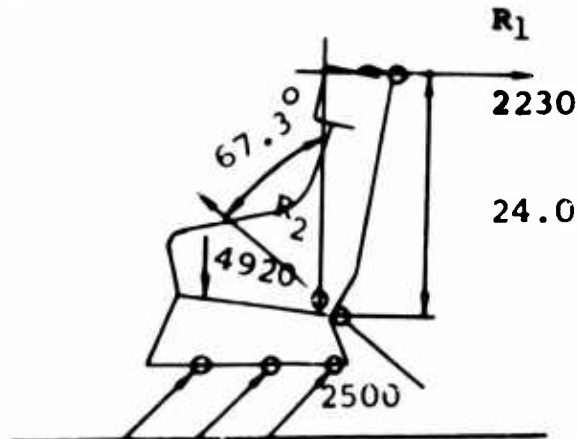

FIGURE 79

$$R_1 = 5100 - 2870 = 2230 \text{ pounds}$$

$$R_2 = 8920 - 4000 = 4920 \text{ pounds}$$

The force R_2 is applied to the seat bucket through the aluminum welded frame which is represented in Boeing-Vertol drawing SK13030. The aluminum frame distributes the load on the seat bucket through 32 rivets.

In this case, the frame acts upon the bucket of the chair as a compression force. Thus the load may be regarded as being completely distributed.

The area of contact is approximately 80 square inches, resulting in a load of approximately 60 psi. This type of load can cause no damage to the Doron bucket.

The force R_1 bends the back of the chair with a moment:

$$M_B = 2230 \cos 30 \times 16.0 = 31,000 \text{ in. - lbs}$$

The bucket of the chair is constructed of Doron, an extremely strong fiberglass laminate.

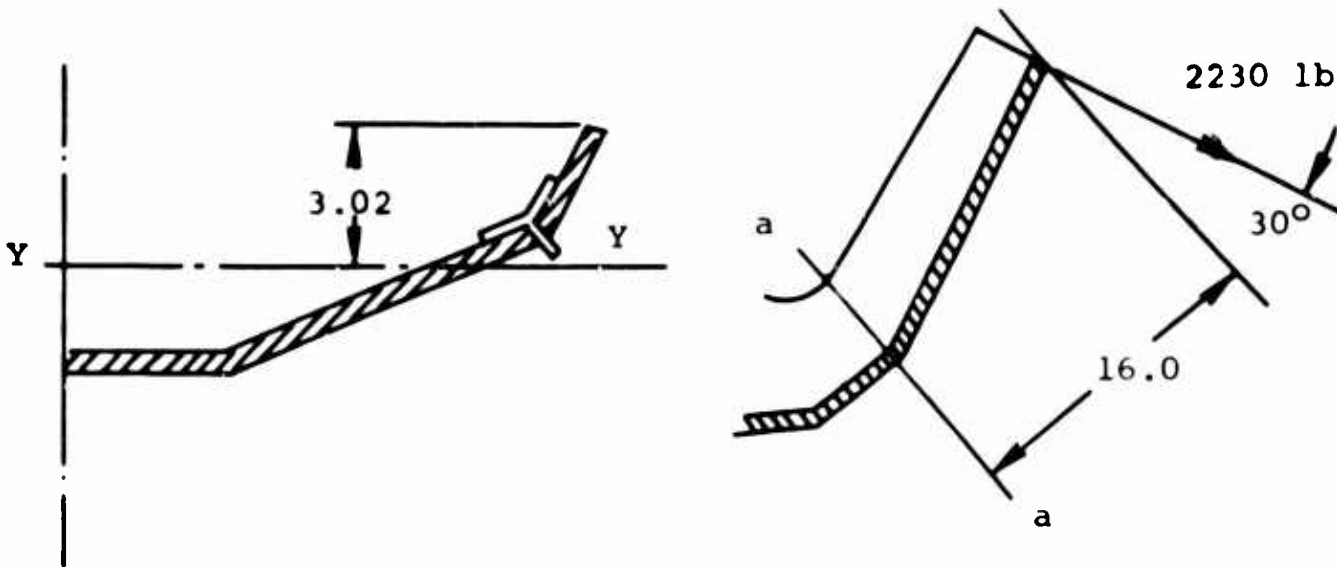

FIGURE 80

The moment of inertia around axis Y-Y:

$$I_{Y-Y} = 8.68 \text{ in.}^4$$

The maximum stress (neglecting the ceramic armor plate and aluminum frame):

$$\bar{\sigma}_b = \frac{M_z}{I} = \frac{31000 \times 3.02}{8.68} = 10,300 \text{ psi}$$

This stress is much less than the material allows in tension ($F_{tu} = 70000 \text{ psi}$). As the compression side is reinforced with ceramic armor plate which provides additional compressive strength, additional analysis is not required.

Analysis of Strength of the Bridge at the Top of
Chair Back - 95th Percentile Man, 45 G Forward

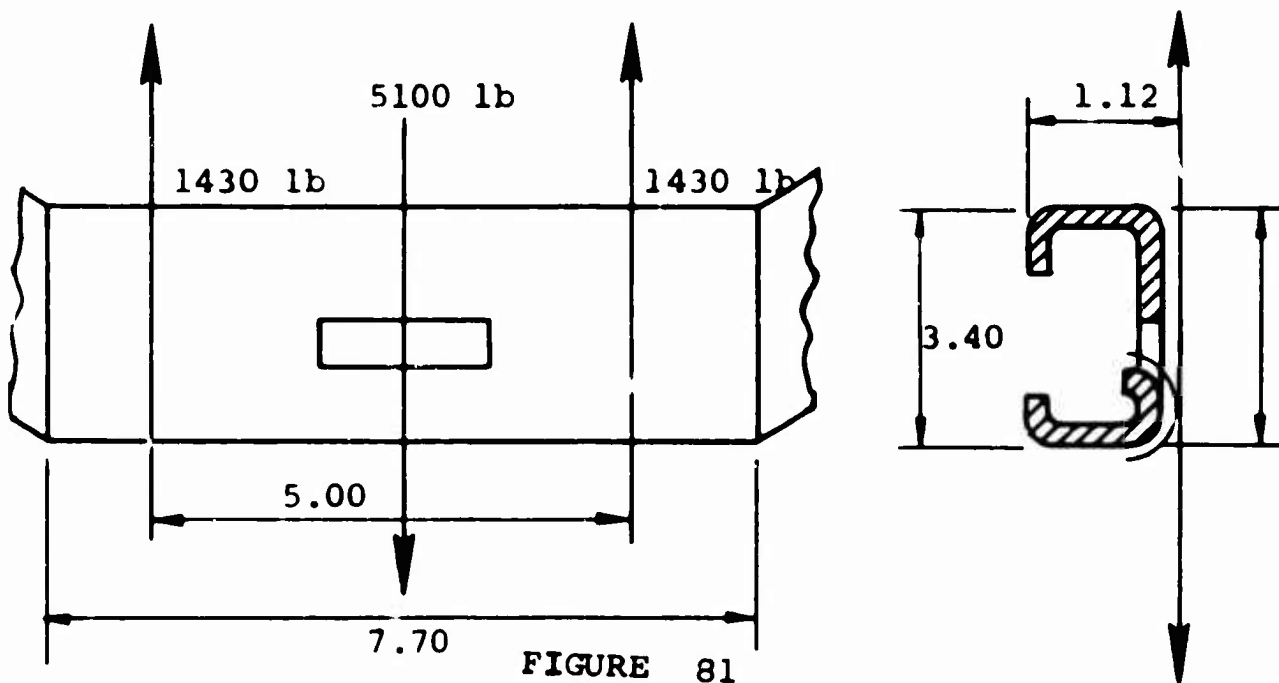

The strap force $P_6 = 5100$ pounds is carried by the channel which is loaded in the opposite direction by the shoulder straps. Part of the load is taken as a uniform distributed load on the structure.

Taking the worst case, wherein the entire 5100 pounds load is balanced by the straps,

$$M_B = \frac{Pl}{4} = \frac{5100 \times 5.00}{4} = 6400 \text{ lb-in.}$$

The moment of inertia at the channel is calculated as indicated below.

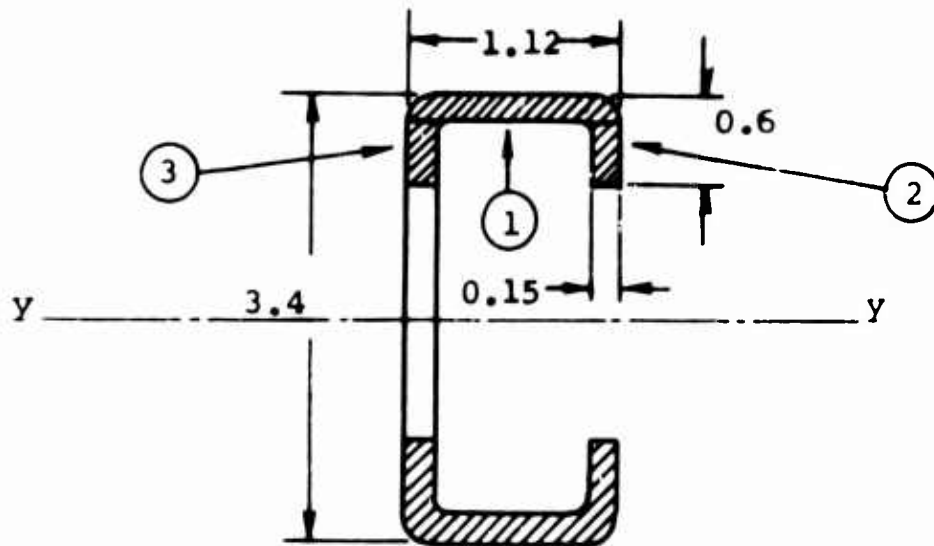

FIGURE 82

Element	A	x	Ax^2
①	0.140	1.64	0.375
②	0.063	1.23	0.095
③	0.063	1.23	0.095
			$\Sigma = 0.562$

$$I = 2 \times 0.562 = 1.12 \text{ in.}^4$$

The bending stress:

$$S_b = \frac{Mxr}{I} = \frac{6400 \times 1.7}{1.12} = 10000 \text{ psi}$$

The allowable bending stress for 61ST is $F_{bu} = 30,000 \text{ psi}$ thus the bridge is completely safe in the case of most severe crash condition.

15. THE CASE OF 45G (BACKWARDS)

This case essentially produces the same or lesser stresses than the case of 45g forward. The chair is restrained by the adjusting screw jack and the Trussgrid blocks. It is highly improbable that both elements will fail, since both can support the load necessary to preserve the integrity of design. Should this failure occur, however, the backward motion of the chair would be stopped by the bulkhead. Thus the case of 45g backwards will not be injurious to the pilot.

16. SUBCONTRACTOR COMPONENTS DATA

- 16.1 The armor seat employs an adjusting screw jack produced by Airborne Accessories Corporation, Hillside 5, New Jersey. The unit has been tested up to a static load of 4350 pounds with satisfactory results. Since, according to this report, the forces acting upon this adjusting screw jack are not higher than those to which the screw jack has been tested, formal stress analysis of the adjusting screw is unnecessary.
- 16.2 The armor seat employs the SK-861 Rev. A Torso Protector Support and Harness Lock, produced by Aircraft Mechanics, Inc. This unit has been tested and certified by Aircraft Mechanics, Inc. for ultimate tension load of 4000 pounds and ultimate compression load of 2000 pounds. The unit functioned normally after conduct of the tests. Therefore, stress analysis of this component need not be included in this report.

BLANK PAGE

Unclassified

Security Classification

DOCUMENT CONTROL DATA - R&D		
<i>(Security classification of title, body of abstract and indexing annotation must be entered when the overall report is classified)</i>		
1 ORIGINATING ACTIVITY (Corporate author) The Boeing Company Vertol Division Morton, Pennsylvania		2a REPORT SECURITY CLASSIFICATION Unclassified
		2b GROUP N/A
3 REPORT TITLE ARMOR PROTECTION FOR PILOT/COPILOT SEAT WITH CRASH SAFETY FEATURES FOR CH-47A HELICOPTER		
4 DESCRIPTIVE NOTES (Type of report and inclusive dates) N/A		
5 AUTHOR(S) (Last name, first name, initial) Thompson, David F., and Harper, Philp		
6 REPORT DATE December 1964	7a TOTAL NO OF PAGES 147	7b NO OF REFS 8
8a CONTRACT OR GRANT NO DA 44-177-AMC-94(T)	9a ORIGINATOR'S REPORT NUMBER(S) USATRECOM 64-73	
b PROJECT NO 1A121401A150	9b OTHER REPORT NO(S) (Any other numbers that may be assigned this report) R-361	
10 AVAILABILITY/LIMITATION NOTICES Qualified requesters may obtain copies of this report from DDC. This report has been furnished the Department of Commerce for sale to the public.		
11 SUPPLEMENTARY NOTES None	12 SPONSORING MILITARY ACTIVITY U. S. Army Transportation Research Command Fort Eustis, Va.	
13 ABSTRACT Pilot/copilot protected crash-safety seat was designed and manufactured. Optimum seat and torso protection was attempted. Detail load and stress analysis for accelerations of 20 g vertically and 45 g longitudinally and laterally was made. By using crushable honeycomb type material, an improved torso restraint system and a variable attenuation mechanism were adopted. The feasibility of using protection media as a load bearing structure was demon- strated.		

DD FORM 1473
1 JAN 64

Unclassified

Security Classification

14 KEY WORDS	LINK A RULE WT	LINK B RULE WT	LINK C RULE WT
INSTRUCTIONS			
<p>1. ORIGINATING ACTIVITY Enter the name and address of the contractor, subcontractor, grantee, Department of Defense activity or other organization (<i>Corporate Authority</i>) issuing the report.</p>	<p>10. AVAILABILITY LIMITATION NOTICES Enter any limitations on further dissemination of the report, other than those imposed by security classification, using standard statements such as:</p>		
<p>2a. REPORT SECURITY CLASSIFICATION Enter the overall security classification of the report. Indicate whether "Restricted Data" is included. Marking is to be in accordance with appropriate security regulations.</p>	<p>(1) "Qualified requesters may obtain copies of this report from DDC." (2) "Foreign announcement and dissemination of this report by DDC is not authorized." (3) "U. S. Government agencies may obtain copies of this report directly from DDC. Other qualified DDC users shall request through _____."</p>		
<p>2b. GROUP Automatic downgrading is specified in DoD Directive 5200.10 and Armed Forces Industrial Manual. Enter the group number. Also, when applicable, show that optional markings have been used for Group 3 and Group 4 as authorized.</p>	<p>(4) "U. S. military agencies may obtain copies of this report directly from DDC. Other qualified users shall request through _____." (5) "All distribution of this report is controlled. Qualified DDC users shall request through _____."</p>		
<p>3. REPORT TITLE Enter the complete report title in all capital letters. Titles in all cases should be unclassified. If a meaningful title cannot be selected without classification, show title classification in all capitals in parenthesis immediately following the title.</p>			
<p>4. DESCRIPTIVE NOTES If appropriate, enter the type of (e.g., interim, progress, summary, annual, or final) inclusive dates when a specific reporting period is involved.</p>			
<p>5. AUTHOR(S) Enter the name(s) of author(s) as shown on the report. Enter last name, first name, middle initial. If military, show rank and branch of service. The name of the principal author is an absolute minimum requirement.</p>	<p>If the report has been furnished to the Office of Technical Services, Department of Commerce, for sale to the public, indicate this fact and enter the price, if known.</p>		
<p>6. REPORT DATE Enter the date of the report as day, month, year, or month, year. If more than one date appears on the report, use date of publication.</p>	<p>11. SUPPLEMENTARY NOTES Use for additional explanatory notes.</p>		
<p>7a. TOTAL NUMBER OF PAGES The total page count should follow normal pagination procedures, i.e., enter the number of pages containing information.</p>	<p>12. SPONSORING MILITARY ACTIVITY Enter the name of the departmental project office or laboratory sponsoring (<i>paying for</i>) the research and development. Include address.</p>		
<p>7b. NUMBER OF REFERENCES Enter the total number of references cited in the report.</p>	<p>13. ABSTRACT Enter an abstract giving a brief and factual summary of the document indicative of the report, even though it may also appear elsewhere in the body of the technical report. If additional space is required, a continuation sheet shall be attached.</p>		
<p>8a. CONTRACT OR GRANT NUMBER If appropriate, enter the applicable number of the contract or grant under which the report was written.</p>	<p>It is highly desirable that the abstract of classified reports be unclassified. Each paragraph of the abstract shall end with an indication of the military security classification of the information in the paragraph, represented as (TS) (S) (C) or (U).</p>		
<p>8b, 8c, & 8d. PROJECT NUMBER Enter the appropriate military department identification, such as project number, subproject number, system numbers, task number, etc.</p>	<p>There is no limitation on the length of the abstract. However, the suggested length is from 150 to 225 words.</p>		
<p>9a. ORIGINATOR'S REPORT NUMBER(S) Enter the official report number by which the document will be identified and controlled by the originating activity. This number must be unique to this report.</p>	<p>14. KEY WORDS Key words are technically meaningful terms or short phrases that characterize a report and may be used as index entries for cataloging the report. Key words must be selected so that no security classification is required. Identifiers, such as equipment model designation, trade name, military project code name, geographic location, may be used as key words but will be followed by an indication of technical context. The assignment of links, rules, and weights is optional.</p>		
<p>9b. OTHER REPORT NUMBER(S) If the report has been assigned any other report numbers (<i>either by the originator or by the sponsor</i>), also enter this number(s).</p>			

BLANK PAGE