

AD61079

SRDS REPORT
NO. RD-64-110

FINAL REPORT

SMALL, LIGHTWEIGHT ALTITUDE
TRANSMISSION EQUIPMENT
(SLATE)

COPY <u>2</u> OF <u>3</u>	<u>221</u>
HARD COPY	\$.3.00
MICROFICHE	\$.0.75

CONTRACT ARDS-476
PROJECT NO. 242-006-01

54P

JULY 1964

DDC
RECEIVED
FEB 12 1965
DDC-IRA E

PREPARED FOR THE
FEDERAL AVIATION AGENCY
SYSTEMS RESEARCH AND DEVELOPMENT SERVICE

BY
TRANSCO PRODUCTS, INC.
VENICE, CALIFORNIA

ARCHIVE COPY

FINAL REPORT

**SMALL, LIGHTWEIGHT ALTITUDE
TRANSMISSION EQUIPMENT**

(S L A T E)

CONTRACT ARDS-476

Project No. 242-006-01

Report No. RD-64-110

SYSTEM RESEARCH & DEVELOPMENT SERVICE

FEDERAL AVIATION AGENCY

JULY, 1964

This report has been prepared by Transco Products, Inc. for the FAA on the above contract. The contents of this report reflect the views of the contractor, who is responsible for the facts and accuracy of the data presented herein, and do not necessarily reflect the official views or policy of the FAA.

TRANSCO PRODUCTS, INC.

Venice, California

Transco Products, Inc.
4241 Glencoe Ave., Venice, California
SMALL, LIGHTWEIGHT ALTITUDE TRANSMISSION EQUIPMENT
Final Report
(Contract FAA/ARDS-476, Project No. 242-006-01, Report No. RD-64-110)

ABSTRACT

This Final Report describes the development of experimental SLATE Transponders, airborne equipment designed primarily for use by General Aviation Aircraft in the Air Traffic Control Radar Beacon (ATCRBS) environment. Four types of transponders were developed, each containing progressive increases in sophistication so that the effectiveness of each type in air traffic control could be separately evaluated.

The Type I reported altitude only (Mode C) in 500 foot increments to 14,500 ft. MSL with a single SPI pulse for identification purposes. The Type II had the added capability of 64 codes or Mode 3/A, with the SPI pulse changed over to Mode 3/A from Mode C. The Type III transponder contained 64 codes and SPI on Mode 3/A, but changed the altitude increments from 500 feet to 100 feet. The Mark I version of the SLATE III increased the code content on Mode 3/A from 64 to 4096.

The altitude encoder which was developed for use with the transponders has two versions; an altitude digitizer for 500 foot increments to 14,500 ft. MSL, and an altimeter-digitizer with normal three-pointer display for 100 foot pressure altitude encoding.

During the development program, several basic designs of transponder circuitry were investigated in an attempt to reduce size, weight, power consumption and cost. This included a magnetic recording encoder/decoder, TRF receiver, digital clock-matrix encoder and various transmitter, I. F. amplifier and SLS circuit configurations.

The final design resulted in a family of SLATE transponders, each weighing under four pounds, with dimensions approximately 3-1/4 x 3-1/4 x 12 inches, all panel mounted units with power consumption under 25 watts.

A cost analysis indicates that the simplest version, the SLATE I, complete with antenna and digitizer, could sell for \$688.00 in lots of 10,000, and the SLATE III (Mark I), the most sophisticated, could sell for \$917.00 each, with antenna and three-pointer display digitizer, in the same quantities.

The SLATE transponders are necessarily complex due to sensitivity, suppression and reply pulse position tolerances which substantially account for the higher than \$500.00 selling price, which was the original target.

This final report includes a brief description of each SLATE type, a discussion of the developmental problem areas, and conclusions and recommendations derived from the program.

TABLE OF CONTENTS

		<u>Page</u>
1.0	General Description	1
1.1	SLATE Type I	1
1.2	SLATE TYPE II	12
1.3	SLATE TYPE III and SLATE TYPE III (Mark I)	20
1.4	Operating Characteristics	32
2.0	Development Problem Areas	33
2.1	TRF Receiver Design	33
2.2	Various Types of Encoders and Decoders	33
2.3	Side Lobe Suppression	46
2.4	Remote Code Selection	46
3.0	Conclusions and Recommendations	48

1.0 GENERAL DESCRIPTION

The SLATE Transponders are experimental units which automatically report digital altitude information in reply to a Mode C interrogation, as well as identification coded replies to a Mode 3/A interrogation on all units except SLATE I.

The SLATE I Transponders only reply with 500 foot increment altitude data; the SLATE II units supplement this with 64 identification codes. SLATE III Transponders contain 64 identification codes and altitude reporting in 100 foot increments; the Mark I version expands the identification codes to 4096.

All SLATE Transponder Sets include digitizer, antenna and interconnecting cabling. The transponders are panel mounted, as are the altimeter-digitizers used with SLATE III's.

1.1 SLATE TYPE I

This section contains pertinent information concerning the physical, mechanical and electrical characteristics of Transco's SLATE Type I, shown in Figure 1, including the antenna and associated altitude-digitizer.

1.1.1 Description, General

The SLATE Type I transponder equipment consists of a transponder, an antenna and an altitude digitizer, as well as necessary interconnecting cables and power cable to utilize either 13.75 volts or 27.5 VDC. The antenna, Transco AT-741/A, is a vertically polarized L-band blade designed to mount on and protrude from the external surface of the aircraft. The altitude digitizer is a sealed unit designed to be mounted in any convenient location where the unit can be interposed in the static line of the

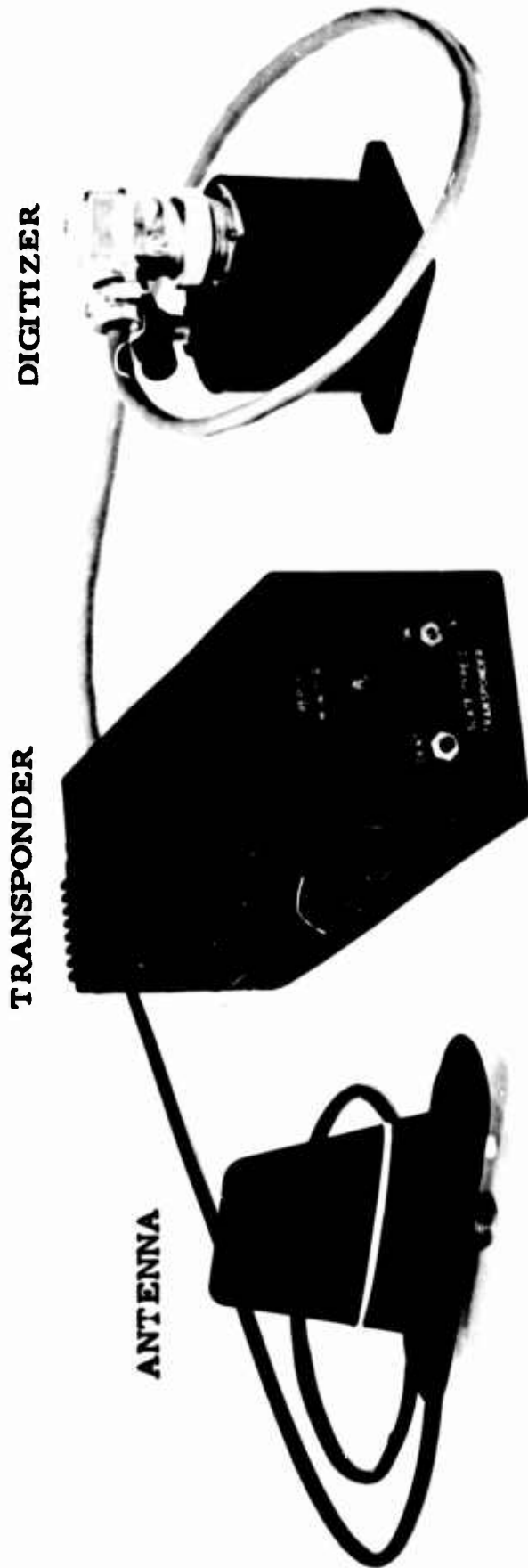

FIGURE 1. SLATE I TRANSPONDER EQUIPMENT

aircraft and interconnected by means of the proper cable to the main transponder unit. The main transponder unit is designed to mount behind the instrument panel in a nominal 3-inch diameter hole. The transponder unit, which weighs four (4) pounds, is 3-1/4 x 3-1/4 x 11-1/4 inches long overall. Necessary connectors to accept cables from the antenna, the altitude - digitizer and the power supply are provided on the rear of the unit. Also mounted on the rear panel is a heat sink for the power supply transistors. The front panel, the round portion of which protrudes from the instrument panel, contains an on-off switch, an identification push-button, and a small glow lamp to indicate transmitter replies. All front and back panel parts are black anodized aluminum except the connectors. Removable top and bottom aluminum covers are perforated to provide ventilation, and finished in a flat black to permit optimum radiation of heat generated by the unit. The top and bottom covers also provide portions of the covering for the sides of the unit. Figures 2 and 3 are photos of the transponder unit with the cover removed showing the construction and framework of the unit, as well as the position and arrangement of the various subassemblies which comprise the transponder. Iridited aluminum side plates integrated into one piece with the rear part of the bottom tie the front and back panels together. A fiberglass circuit board ("mother" board) occupies the forward 4-3/4" of the bottom of the unit. This provides diagonal rigidity to the forward part of the unit and is a means for support and interconnection of the various transistor circuitry subassemblies. Slotted Teflon members are attached to the inside of both side plates above the mother board to guide the individual circuit boards into their proper position when being inserted, as well as to supply rigid, vertical support. Mating spaded pins on the individual circuit boards and the mother board make connections to the individual circuit board when inserted. Wiring under the mother board makes the necessary interconnections between

aircraft and interconnected by means of the proper cable to the main transponder unit. The main transponder unit is designed to mount behind the instrument panel in a nominal 3-inch diameter hole. The transponder unit, which weighs four (4) pounds, is 3-1/4 x 3-1/4 x 11-1/4 inches long overall. Necessary connectors to accept cables from the antenna, the altitude-digitizer and the power supply are provided on the rear of the unit. Also mounted on the rear panel is a heat sink for the power supply transistors. The front panel, the round portion of which protrudes from the instrument panel, contains an on-off switch, an Ident pushbutton, and a small glow lamp to indicate transmitter replies. All front and back panel parts are black anodized aluminum except the connectors. Removable top and bottom aluminum covers are perforated to provide ventilation, and finished in a flat black to permit optimum radiation of heat generated by the unit. The top and bottom covers also provide portions of the covering for the sides of the unit. Figures 2 and 3 are photos of the transponder unit with the cover removed showing the construction and framework of the unit, as well as the position and arrangement of the various sub-assemblies which comprise the transponder. Iridited aluminum side plates integrated into one piece with the rear part of the bottom tie the front and back panels together. A fiberglass circuit board ("mother" board) occupies the forward 4-3/4" of the bottom of the unit. This provides diagonal rigidity to the forward part of the unit and is a means for support and interconnection of the various transistor circuitry subassemblies. Slotted Teflon members are attached to the inside of both side plates above the mother board to guide the individual circuit boards into their proper position when being inserted, as well as to supply rigid, vertical support. Mating spaded pins on the individual circuit board and the mother board make connections to the individual circuit board when inserted. Wiring under the mother board makes the necessary interconnections between

1. 1. 3 DECODER

The decoder consists of the ditch digger, the pulse width decoder and the pulse position decoder. The ditch digger is on the same circuit board as the video amplifier. The ditch digger accepts pulses from the video amplifier and prevents any pulse from reaching the rest of the decoder when closely preceded by a pulse which is only slightly larger in magnitude. In this manner, all echo pulses are suppressed and a means is provided for discriminating between the amplitudes of P_1 and P_2 for sidelobe suppression. All pulses which come through the ditch digger because of proper relative amplitudes are passed on to the pulse width decoder, which is located on circuit board 600. The pulse width decoder, in turn, eliminates all pulses which are not of a duration between 0.5 to 1.0 μ sec. All pulses which are passed by the ditch digger and, in turn, by the pulse width decoder are fed to the pulse position decoder. Pulse position decoder action is initiated by any first pulse, or P_1 . The pulse position decoder performs two main functions. One portion of the decoder allows a P_2 to come through and suppress all further action. Another portion of the pulse position decoder allows P_3 to go through when not inhibited by P_2 , to actuate the encoder, the rate limiter and dead time circuitry, to prevent further reception of interrogations until a proper reply has been made by the transponder. The pulse position decoder is located on circuit board 700. The dead time circuitry, when actuated by an output caused from P_3 in the decoder, gates off the video amplifier so that there is no output from the receiver during the transmission of a reply code. The rate limiter, accepting legitimate P_3 output actuations from the decoder, counts or integrates the actuations and generates a bias which is fed back to the r-f amplifier in the receiver to decrease the receiver's sensitivity, so that only the stronger interrogations come through the receiver to the decoder with sufficient amplitude to be accepted. Dead time circuitry and rate limiter

circuitry are located on the video circuit board 500. The decoder has an output which furnishes an initiating signal to the encoder portion of the transponder.

1. 1. 4 Encoder

All of the circuitry for encoding is contained on three circuit boards. The cope generator occupies board 900, the flip-flops occupy board 851, and the cope matrix occupies board 800. These three sections of the encoder generate all of the necessary framing and altitude code pulses, plus the special position identification (SPI) pulse. The two framing pulses are fed directly to the cope matrix output gate for each reply. The altitude-digitizer selects appropriate A and B pulses to be included in the encoder gate output. When the Ident button on the front panel is pressed momentarily, the SPI timer, which is located on the cope generator circuit board, causes the altitude code pulses to be dropped and SPI to be selected for inclusion with the two framing pulses in the output.

1. 1. 5 Modulator-Transmitter

Output pulses from the encoder are fed to a modulator-driver and a lamp-driver, both of which convert the signal out of the encoder to proper outputs in order to drive the modulator and the monitor lamp. The modulator-driver and the lamp-driver are located on video circuit board 500. The monitor lamp is flashed for each reply to give indication of proper response by the transponder. The modulator keys the transmitter for each reply pulse, providing the necessary r-f output to the diplexer and the antenna.

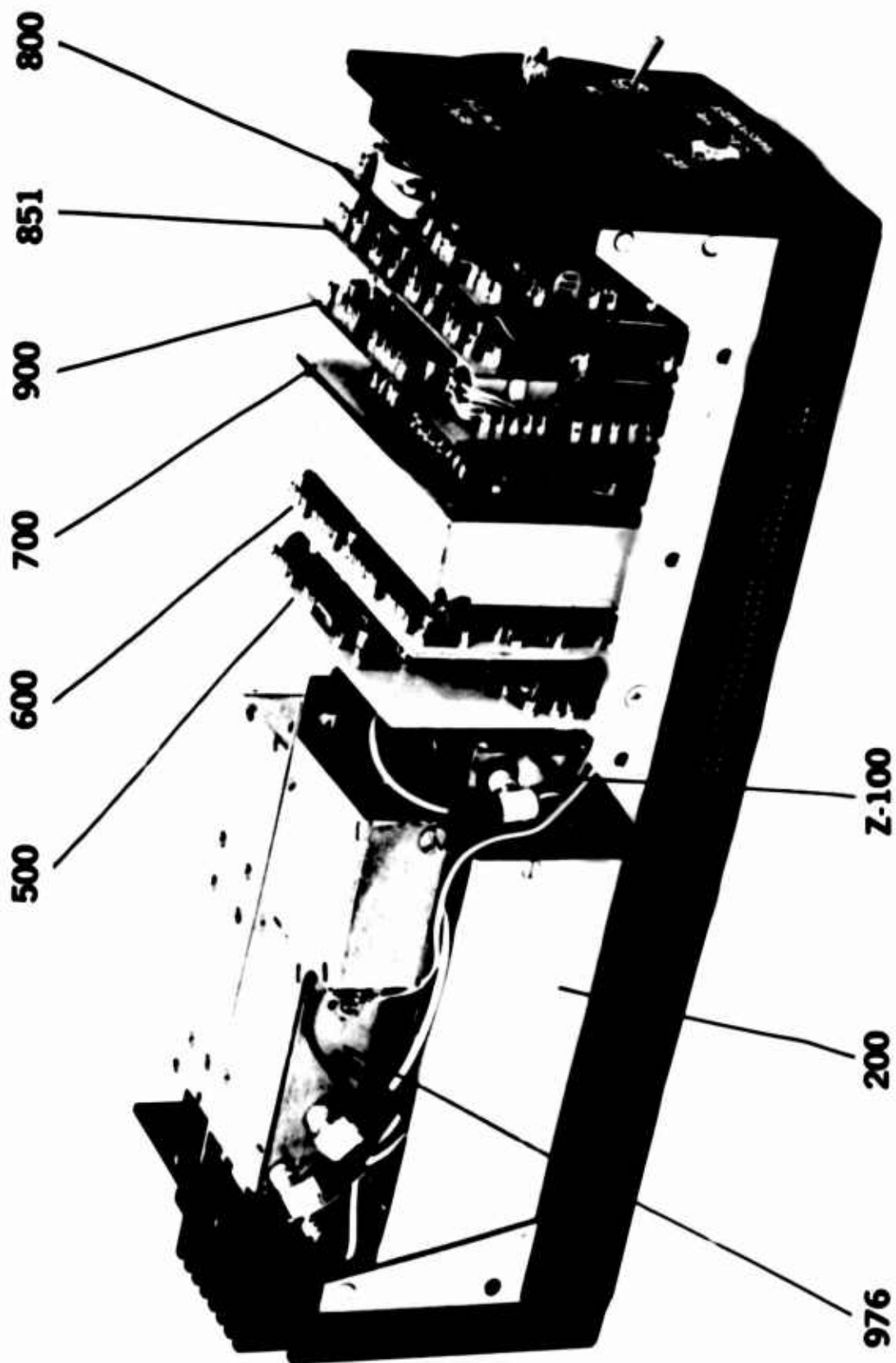

FIGURE 2

FIGURE 2. SLATE I TRANSPONDER UNIT (LEFT VIEW)

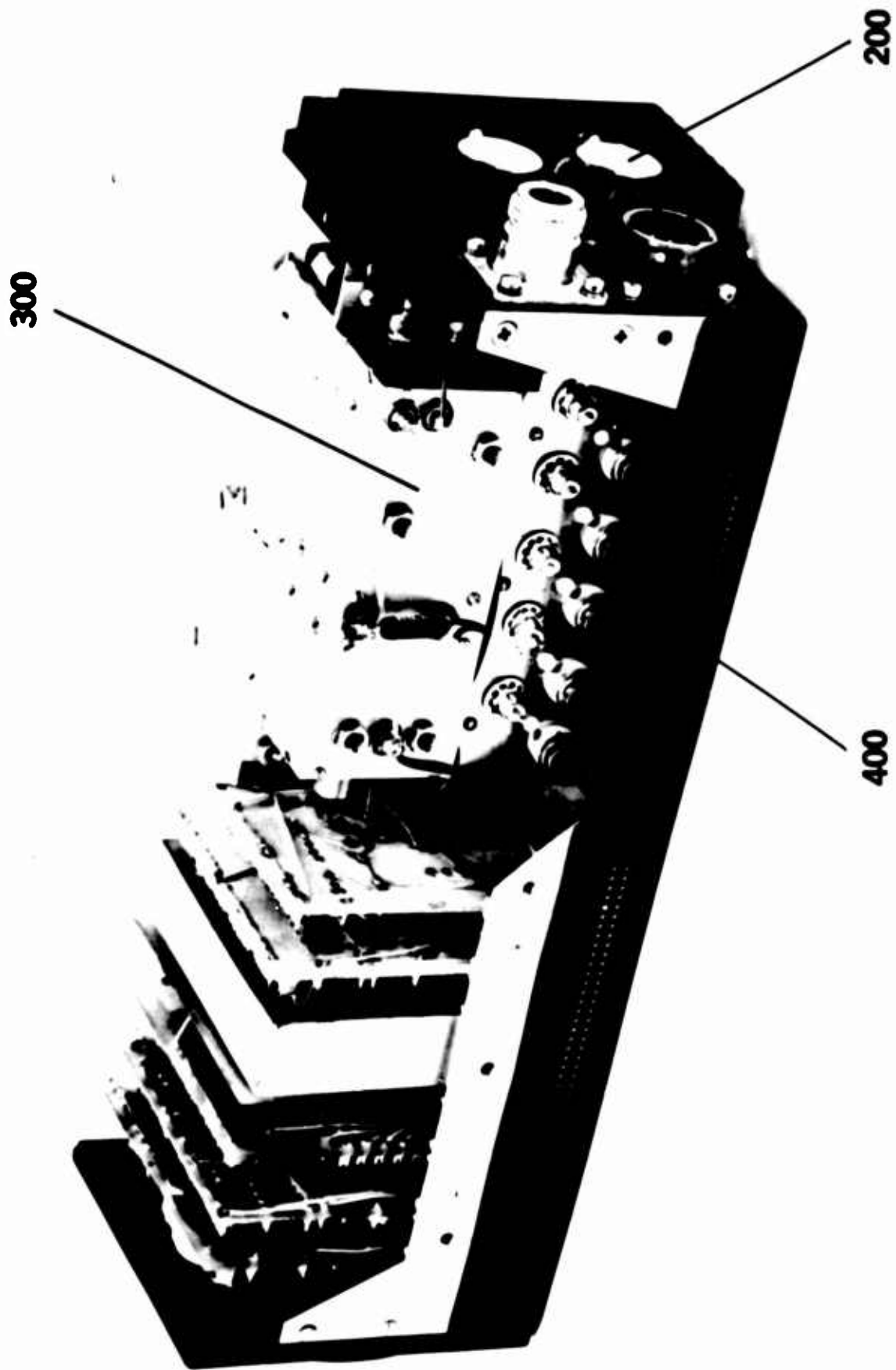

FIGURE 3

FIGURE 3. SLATE I TRANSPONDER UNIT (RIGHT VIEW)

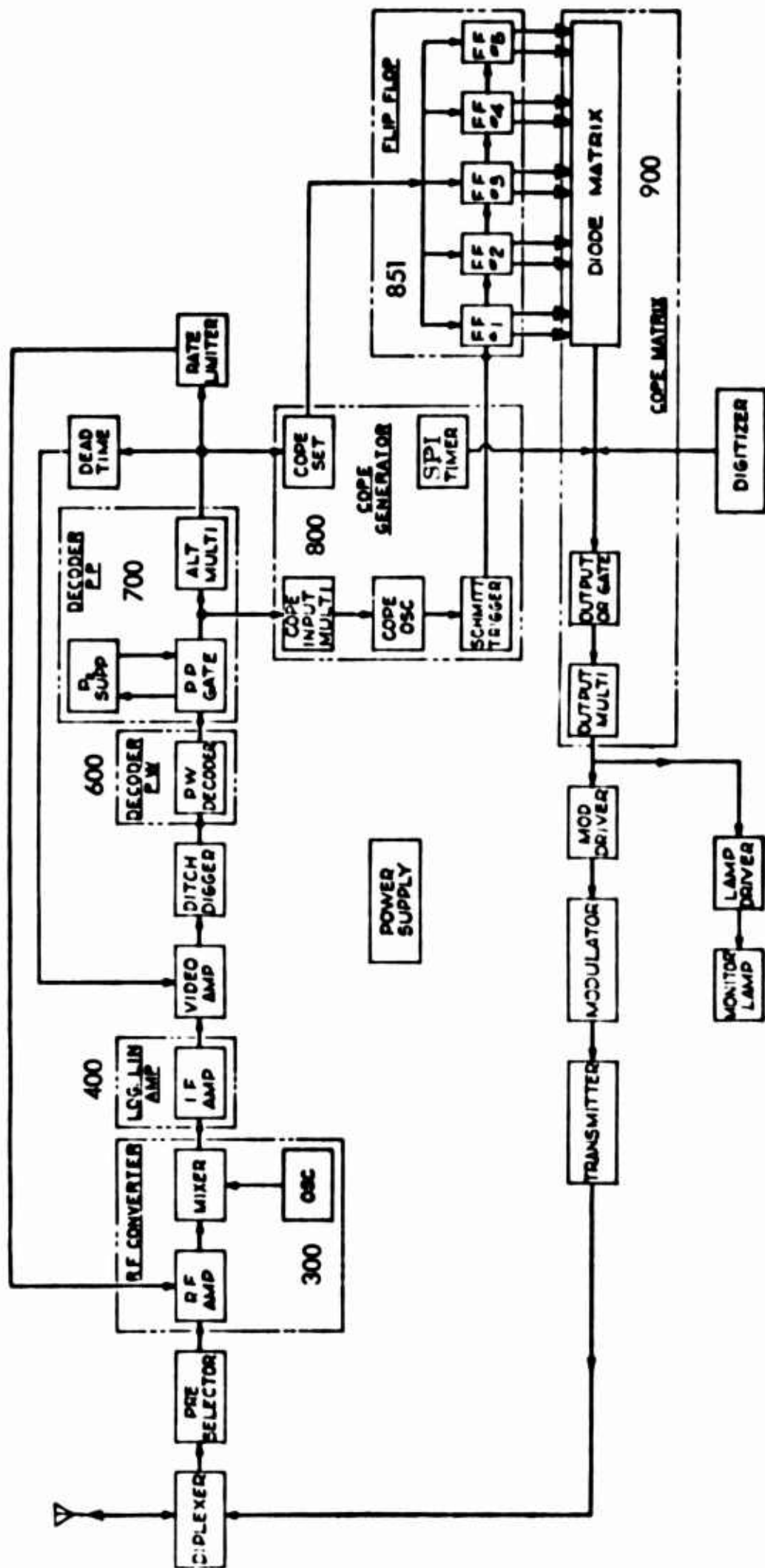

Figure 4. Block Diagram, SLATE I

1.1.6 Power Supply

The power supply converts either 13.75 volts or 27.5 volts to the transponder for all necessary voltages of the circuitry. Supply voltages required by the transponder from the power supply are 1000 VDC to the transmitter, 125 VDC to the modulator and the r-f converter, regulated 10 VDC to the transistor circuitry and 6.3 VAC for filaments in the r-f converter and the transmitter.

1.1.7 Altitude Digitizer

The altitude digitizer is a pressure sensitive device which encodes the reply to a Mode C interrogation. The unit is shown pictorially in Figure 5. The digitizer contains a series of aneroid capsules connected to a shaft via a special linear to rotary converter. The case is connected to the aircraft static pressure system which feeds the altimeter. As the aircraft climbs, the static pressure is reduced and the sealed aneroid capsules expand, causing the shaft to rotate. A shaft encoder is included, consisting of a disc on which the ICAO altitude code is plated in metallic segments, with five brush contacts and a common return. The electrical contacts are brought to a sealed multipin connector on the front of the unit where an interconnecting cable feeds the switch contacts to the transponder for reply pulse selection. The altitude coding employs the A₂, A₄, B₁, B₂ and B₄ pulses which are selected through the or gates at the outputs of the diode matrix in the transponder. The reply code is in increments of 500 feet from -1000 to +14,500 with respect to a fixed MSL datum of 29.92" Hg. The altitude mechanism of the altitude digitizer meets the requirements of TSO C-10b.



ALTITUDE-DIGITIZER

FIGURE 5.

1.2 SLATE TYPE II

1.2.1 Description, General

The SLATE Type II transponder equipment consists of a transponder, an antenna and an altitude - digitizer, as well as necessary interconnecting cables and power cable to the 13.75 volts DC supply. The antenna, Transco AT-741/A, is a vertically polarized L-band blade designed to mount on and protrude from the external surface of the aircraft. The altimeter digitizer is a sealed unit designed to be mounted in any convenient location where the unit can be interposed in the static line of the aircraft, and interconnected by means of the proper cable to the main transponder unit. The main transponder unit is designed to mount behind the instrument panel in a nominal 3-inch diameter hole. The transponder unit, which weighs four (4) pounds, is 3-1/4 x 3-1/4 x 11-1/4 inches long overall. Necessary connectors to accept cables from the antenna, the altimeter digitizer and the power supply are provided on the rear of the unit. Also mounted on the rear panel is a heat sink for the power supply transistors. The front panel, the round portion of which protrudes from the instrument panel, contains code selector switches, an on-off switch, a spring loaded IDENT/Standby switch and a small glow lamp to indicate transmitter replies. Figures 7 and 8 are photos of the transponder unit with the cover removed showing the construction and framework of the unit, as well as the position and arrangement of the various subassemblies which comprise the transponder. This particular arrangement allows removal and reinsertion of transistor circuit boards for ease of repair or replacement by new circuit boards. All boards can be removed individually except boards 851 and 900 which plug together before being inserted and must be removed together. Six fiberglass circuit boards in this group contain all of the transistor circuitry with the exception of the i-f amplifier and the final modulator transistor. The power supply with a completely enclosed shield box is fastened to the inside of the heat sink held by the rear panel.



FIGURE 6. SLATE II TRANSPONDER EQUIPMENT

1.2.2 Receiver

Referring to the overall block diagram of Figure 9, the receiver consists of the antenna, a portion of the diplexer, the pre-selector, the rf converter, the log linear i-f amplifier and the video amplifier. Signals from the antenna pass through the diplexer, which is a system of special cable lengths providing isolation between the receiver and the transmitter to reach the pre-selector, which is shown as Z100 in the photographs. The pre-selector provides additional rejection of the transmitted signals and also adds to skirt selectivity and image rejection. The r-f converter, designated as Package 300 in the photographs and consisting of the r-f amplifier, mixer and oscillator, accepts signals from the pre-selector and converts them to 60 mc i-f. The log-linear i-f amplifier, designated as Package 400 in the photographs, amplifies the weak signals and passes them on, with sufficient amplitude, to the video amplifier. The transistor circuit board, designated in the photographs as 500, contains the video amplifier, which is only a small portion of the circuitry on that board. The video amplifier adds enough additional amplification to the receiver's output to drive all of the decoder processes. The video amplifier provides a gain of ten through its emitter output stage to provide a low impedance source which prevents loss due to loading by the decoder input.

1.2.3 Decoder

The decoder consists of the ditch digger, the pulse width decoder and the pulse position decoder. The ditch digger is on the same circuit board as the video amplifier. The ditch digger accepts pulses from the video amplifier and prevents any pulse from reaching the rest of the decoder when closely preceded by a pulse which is only slightly larger in magnitude. In this manner all echo pulses are suppressed and a means is provided for discriminating between the amplitudes of P₁ and P₂ for sidelobe suppression. All pulses which come through the ditch digger because of proper relative amplitudes are passed on to the pulse width decoder, which is located on

circuit board 600. The pulse width decoder, in turn, eliminates all pulses which are not of a duration between 0.5 and 1.1 μ sec. All pulses which are passed by the ditch digger and, in turn, by the pulse width decoder are fed to the pulse position decoder. Pulse position decoder action is initiated by any first pulse, or P_1 . The pulse position decoder performs two main functions. One portion of the decoder allows a P_2 to come through and suppress all further action. Other portions of the pulse position decoder allow P_3 to go through when not inhibited by P_2 , to actuate the encoder, the rate limiter and dead time circuitry, to prevent further reception of interrogations until a proper reply has been made by the transponder. The pulse position decoder is located on circuit board 700. The dead time circuitry, when actuated by an output caused from P_3 in the decoder, gates off the video amplifier so that there is no output from the receiver during the transmission of a reply code. The rate limiter, accepting legitimate P_3 output actuations from the decoder, counts or integrates the actuations and generates a bias which is fed back to the r-f amplifier in the receiver to decrease the receiver's sensitivity so that only the stronger interrogations come through the receiver to the decoder with sufficient amplitude to be accepted. Dead time circuitry and rate limiter circuitry are located on the video circuit board 500. The decoder has an output which furnishes an initiating signal to the encoder portion of the transponder.

1.2.4 Encoder

All of the circuitry for encoding is contained on three circuit boards. The COPE generator occupies board 800, the flip-flops occupy board 851 and the COPE matrix occupies board 900. These three sub-assemblies of the encoder generate all of the triggers properly spaced with respect to any P_3 to generate framing, altitude code and identification

code pulses, plus the special identification pulse. Triggers for the two framing pulses are fed directly to two separate "or" gates for each reply, one of which is for identification and the other for altitude replies. The altitude-digitizer selects appropriate triggers for the A and B pulses to be included in the encoder output while the selector switches on the front panel of the unit select appropriate trigger pulses to generate the required code for identification. When the spring loaded IDENT button on the front panel is pressed momentarily, the special identification pulse timer passes the appropriate trigger for SPI to the identification "or" gate. Fixed and selected triggers from the altitude "or" gate or from the identification "or" gate are further gated to a code pulse output multivibrator by either the identification multivibrator or the altitude multivibrator in the decoder as actuated alternately by P_3 from Modes A and C. This code pulse output multivibrator generates a uniform pulse for each trigger pulse that is passed on to it. The train of code pulses thus generated is passed on to the modulator.

1.2.5 Modulator-Transmitter

Output pulses from the encoder are fed to a modulator-driver and a lamp-driver, both of which convert the signal out of the encoder to proper outputs in order to drive the modulator and the monitor lamp. The modulator-driver and the lamp-driver are located on video circuit board 500. The monitor lamp is flashed for each reply to give indication of proper response by the transponder. The modulator keys the transmitter for each reply pulse, providing the necessary r-f output to the diplexer and the antenna.

1.2.6 Power Supply

The power supply converts 13.75 volts to all necessary voltages for the transponder circuitry. Supply voltages required by the transponder

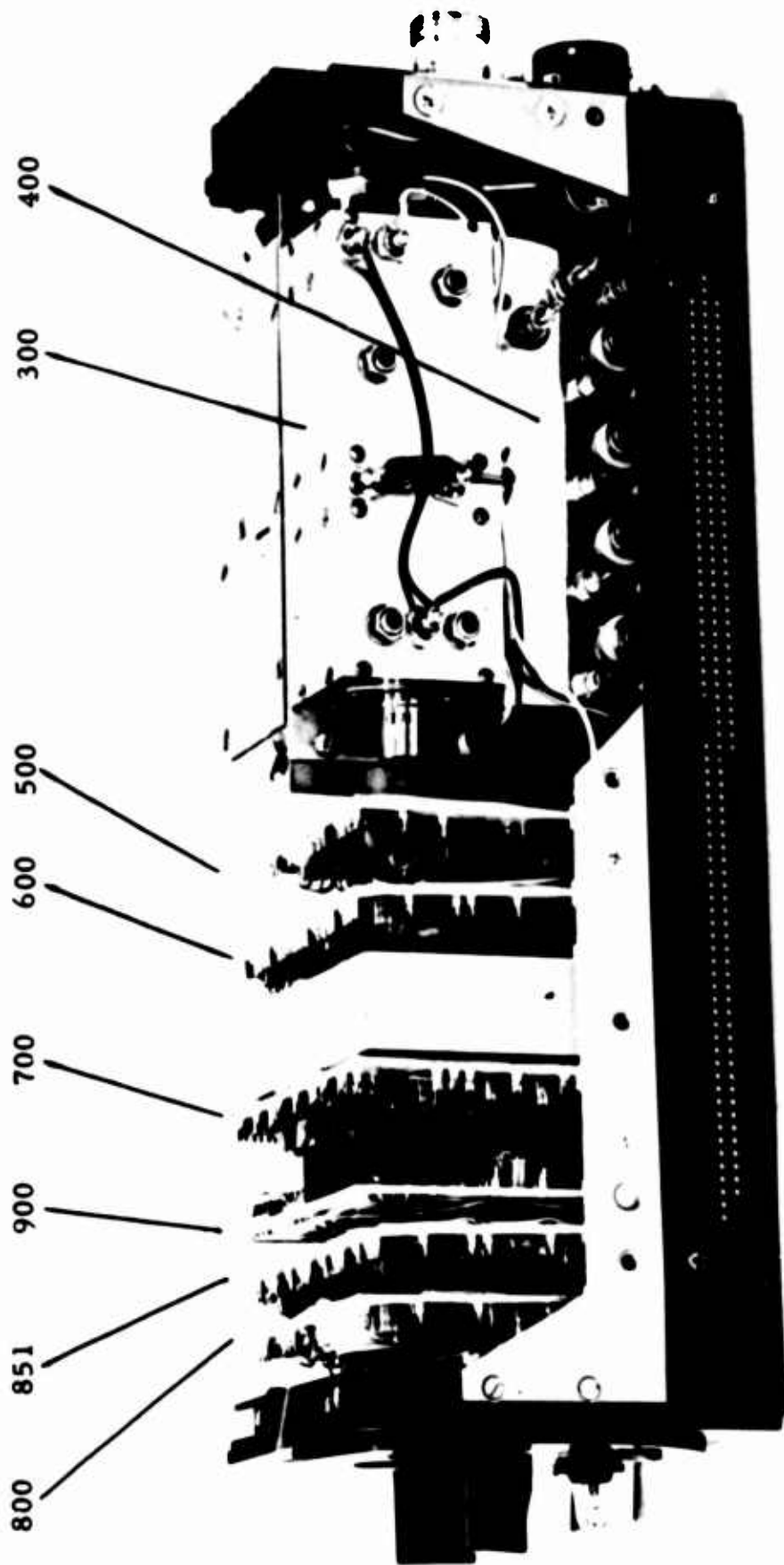

FIGURE 7. SLATE II TRANSPONDER UNIT (RIGHT VIEW)

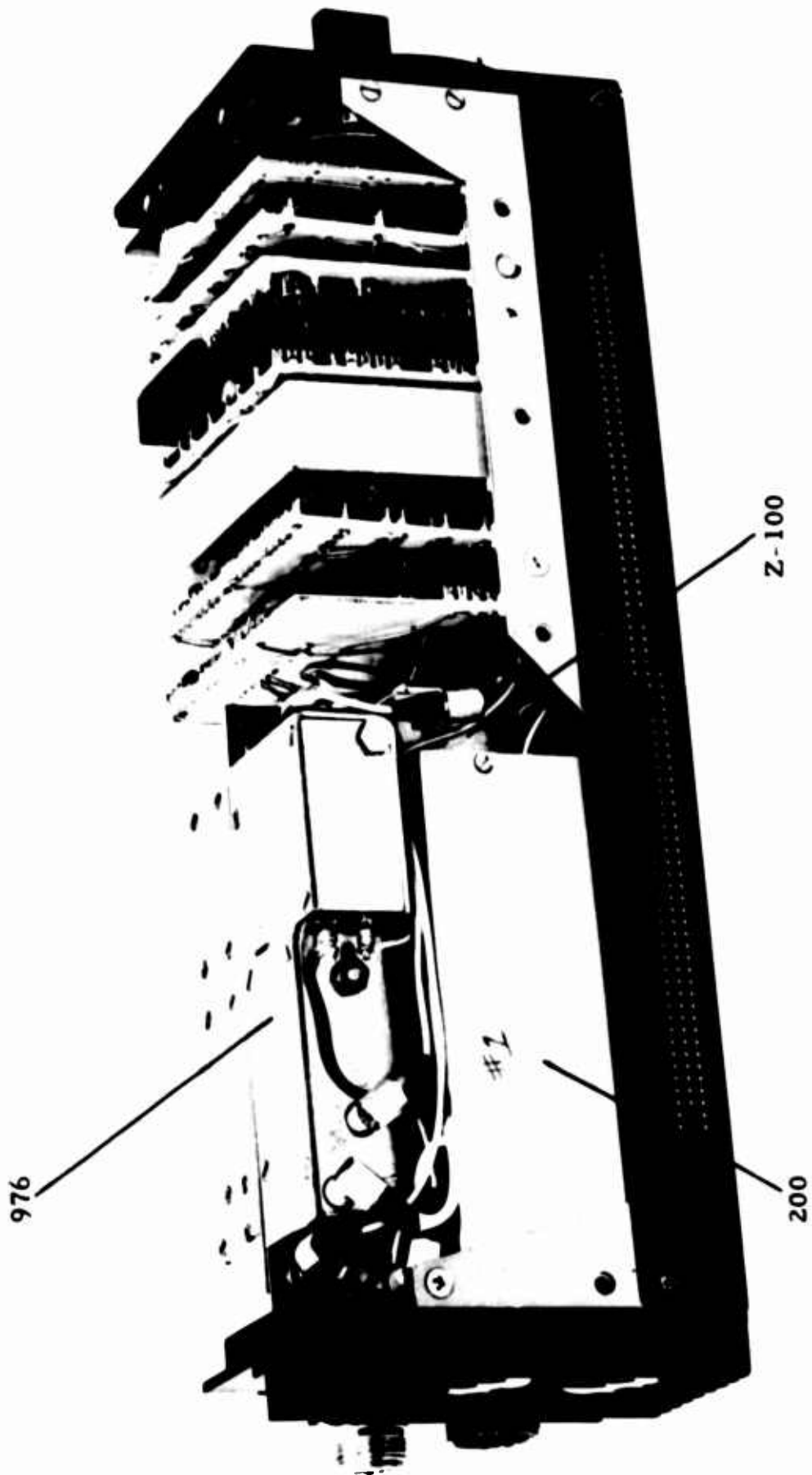

FIGURE 8. SLATE II TRANSPONDER (LEFT VIEW)

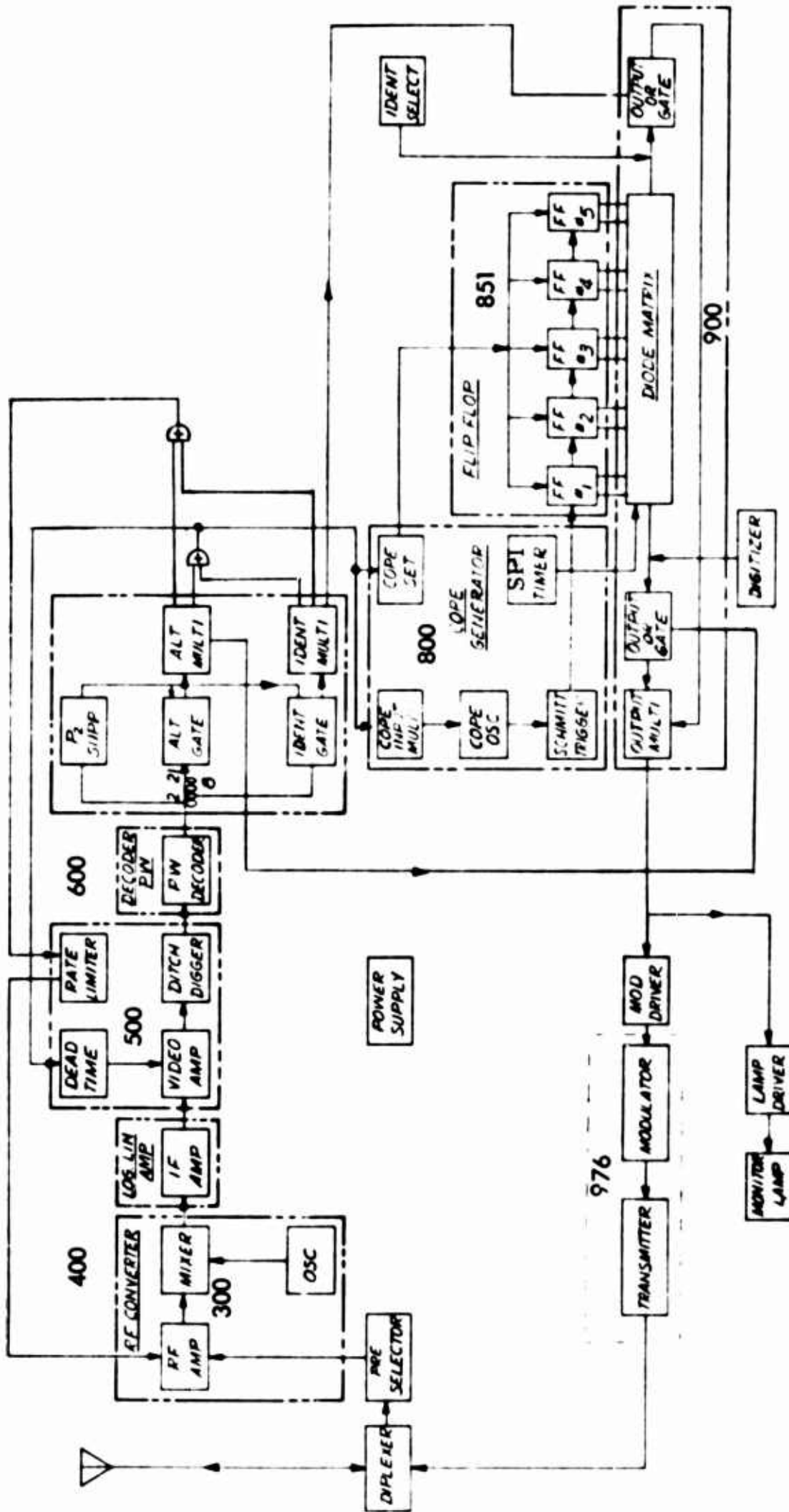

Figure 9. Block Diagram, SLATE II

from the power supply are 1000 VDC to the transmitter, 125 VDC to the modulator and the r-f converter, regulated 10 VDC to the transistor circuitry and 6.3 VAC for filaments in the r-f converter and the transmitter.

1.3 SLATE TYPE III AND SLATE III (MARK I)

1.3.1 Description, General

The Transco SLATE Type III employs semiconductors in all circuitry except for local oscillator, r-f amplifier and transmitter. The SLATE transponder is a self-contained package minus antenna and digitizer which may be operated from a standard 13.75 VDC aircraft electrical system. No AC power is required.

The transponder contains eleven basic subassemblies (see Figure 12). The chassis, power supply, r-f assembly, i-f strip, video processor, pulse-width discriminator, pulse position discriminator, cope generator, matrix driver, cope matrix and the code selector. These eleven subassemblies are all contained in a 4 lb. package.

1.3.2 R. F. Assembly

The r-f assembly (300 series) not only contains the front end or converter, but also the transmitter section. The converter stage consists of a preselector, r-f amplifier, local oscillator and mixer.

The converter is shown pictorially in Figure 12. The preselector is a double-tuned circuit with an input loop and an output coupled to a transmission line in a cavity. Incoming r-f signals from the preselector are coupled to the low impedance cathode of a grounded grid amplifier. This is a nuvistor r-f amplifier with a resonant plate cavity tuned to 1030 mc. Signals from the plate line are iris-coupled to the mixer tuned circuit.

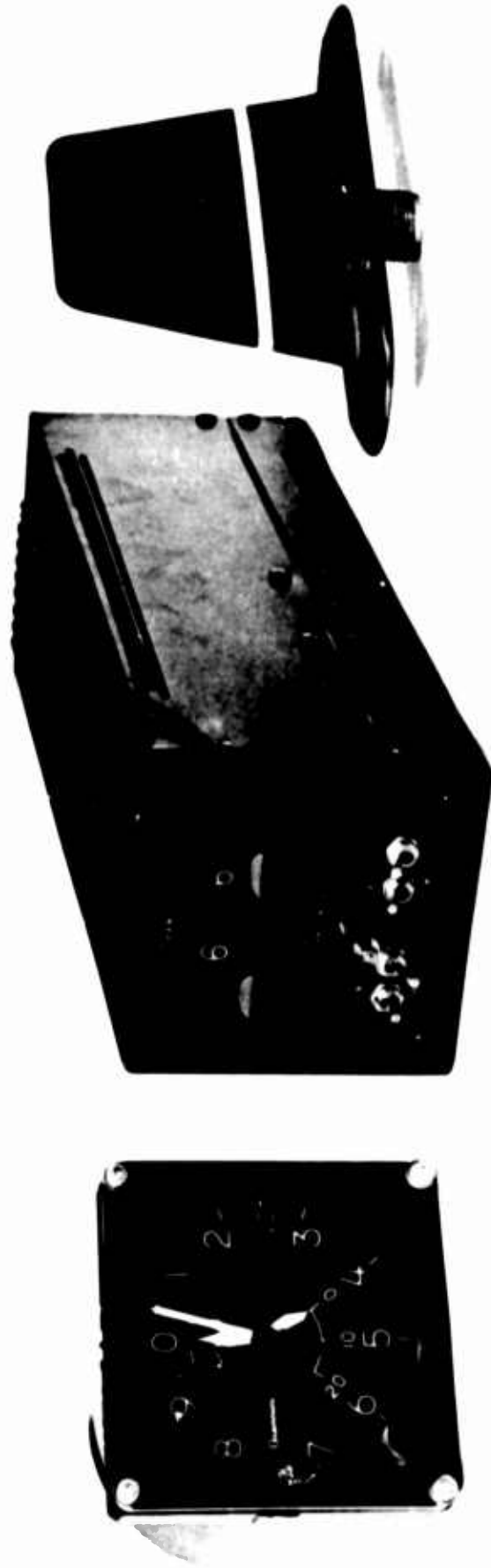

FIGURE 10.
SLATE TYPE III
TRANSPONDER EQUIPMENT

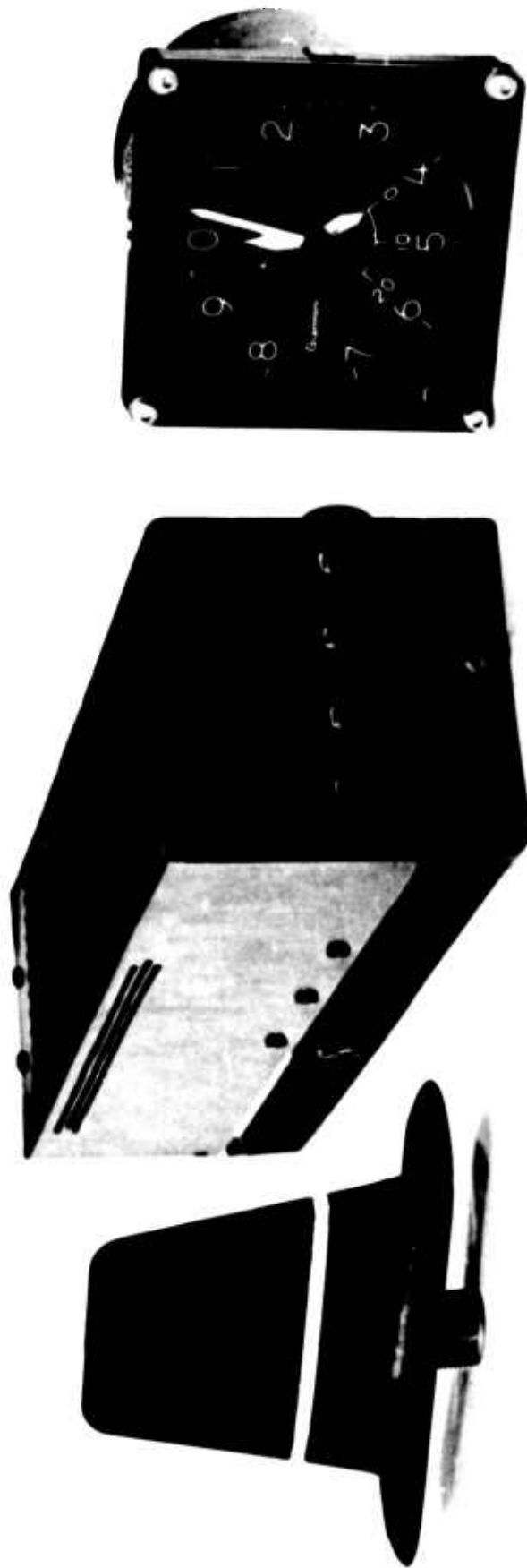

FIGURE 11.
SLATE TYPE III (MARK I)
TRANSPONDER EQUIPMENT

The local oscillator is a nuvistor triode operated at 970 mc/s. Iris coupling is used along with inner-electrode capacitance to maintain oscillation. Both plate and grid circuits are individually tuned. Signals from the local oscillator are iris-coupled to the mixer section. The mixer tuned line is resonated at 1030 mc.

1.3.3 Intermediate Frequency Amplifier

The i-f strip, consisting of low impedance bandpass input filter and four transistor amplifier stages, delivers in excess of 80 db gain. Selectivity and adequate rejection is provided by four synchronously tuned inductors in the collector stages of the transistors, as well as the bandpass of the input filter, all operating at a center frequency of 60 mc/s. The overall 3 db bandwidth is 8.0 mc/s.

The input filter for the i-f strip is a triple tuned bandpass filter which is made up of fixed capacitors and variable inductances. The four neutralized i-f stages employ transistors with a common emitter configuration. The transistors used have a typical matched neutralized available power gain of 28 db at 60 mc/s. There is an intentional loss and mismatch, however, to enhance the gain and bandwidth stability.

Video is detected from each of the collectors in the four i-f stages by diodes and summed across a resistor through individual successive delays to the adder bus, then presented at the output. The effect of this progressive system is to produce a video output signal whose amplitude is logarithmically related to the applied input signal. The increase of input i-f pulses from -74 dbm to -24 dbm causes a linear increase of video impulses from 0.10 volts to just under 0.5 volts, representing a compression of the 50 db input range to approximately 14 db output range. This compression, without loss of relative amplitude, allows subsequent circuitry to

discriminate between pulses on the basis of amplitude over a large dynamic range of input signals.

1.3.4 Video Processor

The video processor board (500 series) contains the video processor section, dead time, rate limiter circuits and lamp driver. The video amplifier is a two-stage direct coupled amplifier stabilized at ten times gain.

In operation, a pulse from the video amplifier is applied to the ditch digger and the differential comparator. This charges a timing capacitor and provides an output which turns on the hybrid trigger for the width of the pulse. The trigger output is inverted and fed to the pulse-width discriminator and simultaneously to the three μ sec monostable (on code selector board). The monostable turns off and prevents discharge for three μ sec. A closely following pulse must be larger than the initial pulse to cause an output from the differential comparator, thus providing the required side lobe suppression gain characteristic. After three μ sec, the charge on the capacitor decreases at the proper rate to provide the required echo gain characteristic.

1.3.5 Dead Time Circuit

The dead time circuit consists of an NPN silicon transistor operated as a switch to disable the video amplifier. The output from either reply monostable consists of a positive pulse approximately 35 μ sec duration. This pulse is coupled into the base of the transistor to suppress further signals from the receiver until after the reply.

1.3.6 Rate Limiter Circuit

The rate limiter circuit consists of an RC transistor integrator with a counter and two amplifiers. Should the number of pulses placed on its input exceed a preset number, the common emitter amplifier will begin to conduct, thus lowering the voltage applied to the first stage of the i-f, thereby lowering the gain of the overall system.

1.3.7 Pulse Width Discrimination

The primary purpose of the pulse width discriminator (PWD) is to determine whether the transponder is to reply or suppress with regard to a given pulse width. This is accomplished by means of gates, delay lines and monostables. The proper mode of operation is between the limits of 0.45 and 1.1 μ sec (nominally). All of the component parts are on the 600 series circuit board.

1.3.8 Pulse Position Discriminator

The pulse position decoder on the 700 series circuit board (Figure 12) has a purpose that is twofold; first, the PPD must ascertain whether the P₂ pulse is present and, if so, it must suppress the P₃ gates, thereby causing side lobe suppression; secondly, the PPD must determine the position and tolerance of the P₃ pulse. The proper pulse position and tolerance must be $2 \pm 1 \mu$ sec for P₂ and 8 ± 1 or $21 \pm 1 \mu$ sec for P₃.

1.3.9 Cope Generator and SPI Timer

The 800 series circuit card consists of the cope generator, input multivibrator, oscillator, Schmitt trigger and an inverter. Also on this card is the SPI timer.

The input multivibrator, when triggered from the decoder, generates a pulse with a duration longer than the reply period (25 to 30 μ sec). This pulse keys the shock excited oscillator for its duration to produce a train of sine waves. The train of uniform frequency sine waves are then applied to the Schmitt trigger to produce clock pulses.

The SPI timer circuit provides one pulse for each reply train, following F_2 by 4.35 μ sec for a duration of approximately 20 seconds, when the Ident switch is activated.

1.3.10 Flip-Flops

Five identical flip-flops on circuit board 851, shown in Figure 12 are connected in series to provide a binary counter. A train of pulses from the inverter on the cope generator card, when applied to these flip-flops cause ten separate voltage states to assume a different combination for each successive pulse. With a logical selection of these voltage states, plus the A inputs, the cope matrix is capable of generating triggers for each of the reply pulses. The required number of combinations of states needed to generate a full reply code, including SPI, is 18. The number of triggering pulses are 21 to 22, slightly in excess of the number required.

1.3.11 Cope Matrix

The circuit board (900) is shown in Figure 12. It contains a "and" logic diode matrix, isolating diodes for each matrix output, two "or" gates to pass triggers selected (by identity or altitude means) and a monostable multivibrator to generate uniform reply pulses for each trigger.

The diode matrix consists of 12 inputs and 15 output buses with diodes connecting a particular output bus to certain inputs. Any output bus cannot have high voltage (near 10 volts) on it unless every diode connected to it has a high voltage impressed on its input. The momentary rise in voltage on a bus for one particular binary count is a trigger pulse of one count duration at that matrix output.

1.3.12 Code Selector

The code selector board (Series 951) contains the reply code selection circuitry, the suppression circuitry and the three μ sec monostable for the video processor.

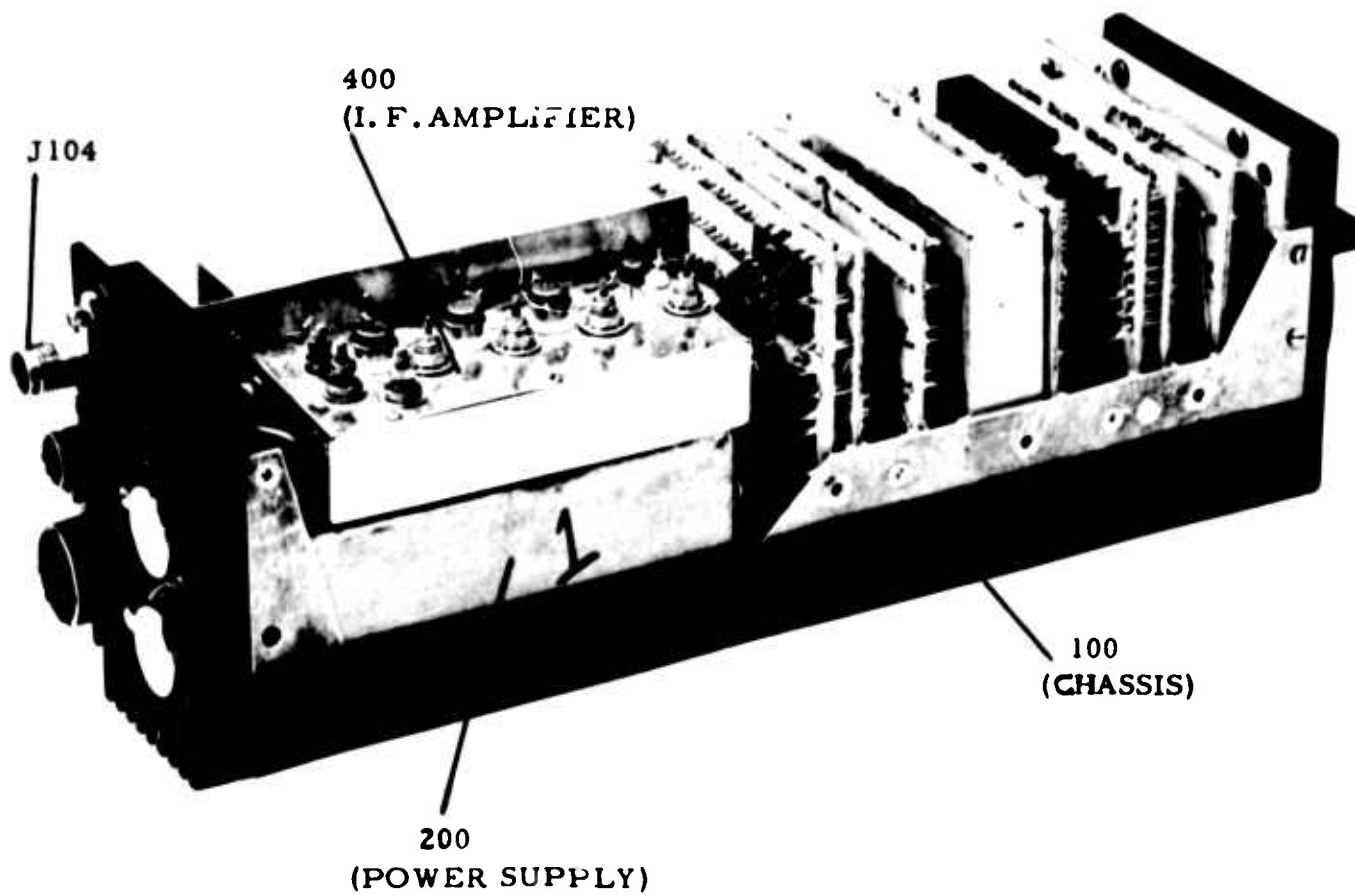
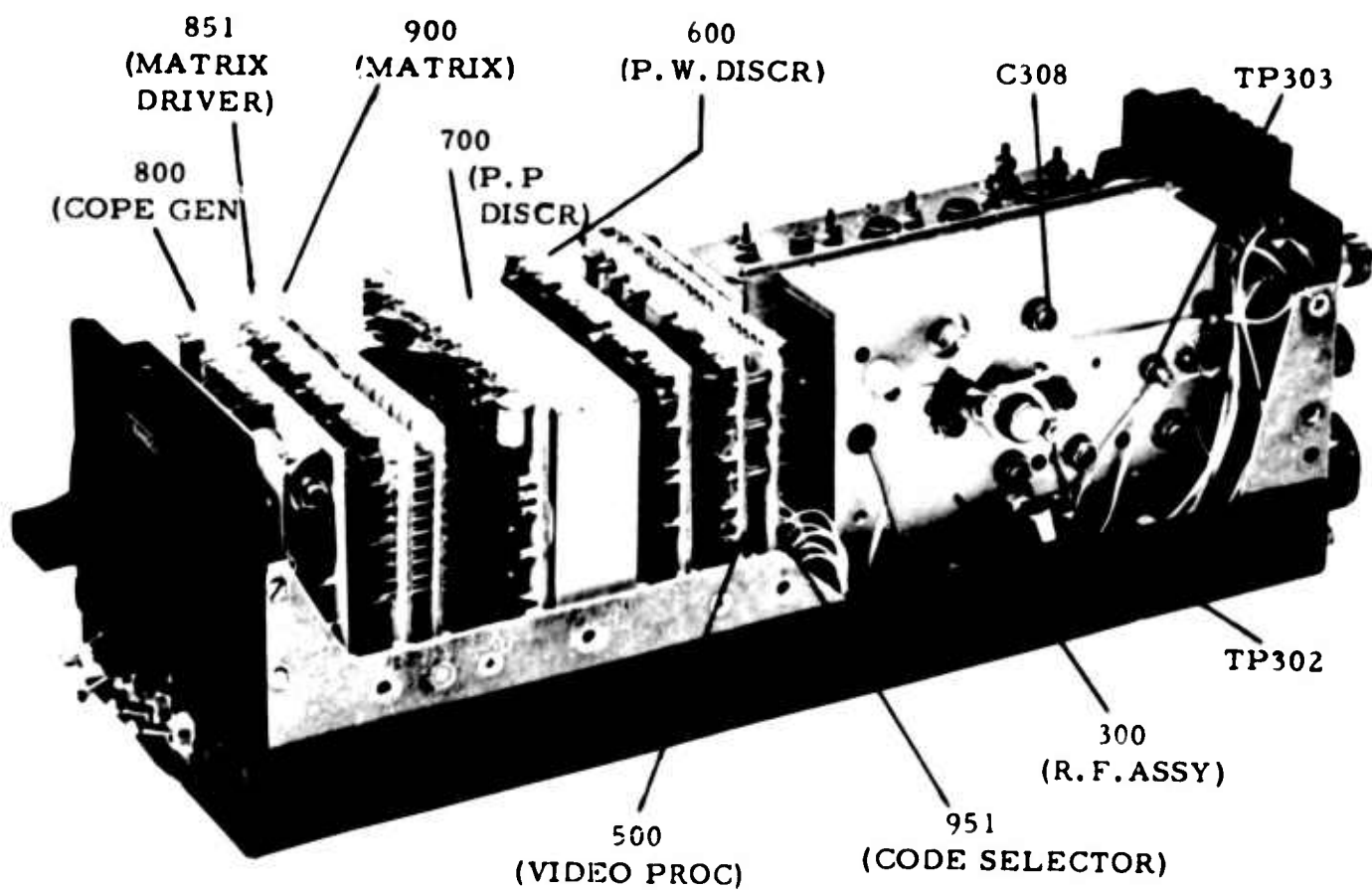

FIGURE 12.
 SLATE III TRANSPONDER

102D10005

REV	DESCRIPTION	DATE	APPROVAL

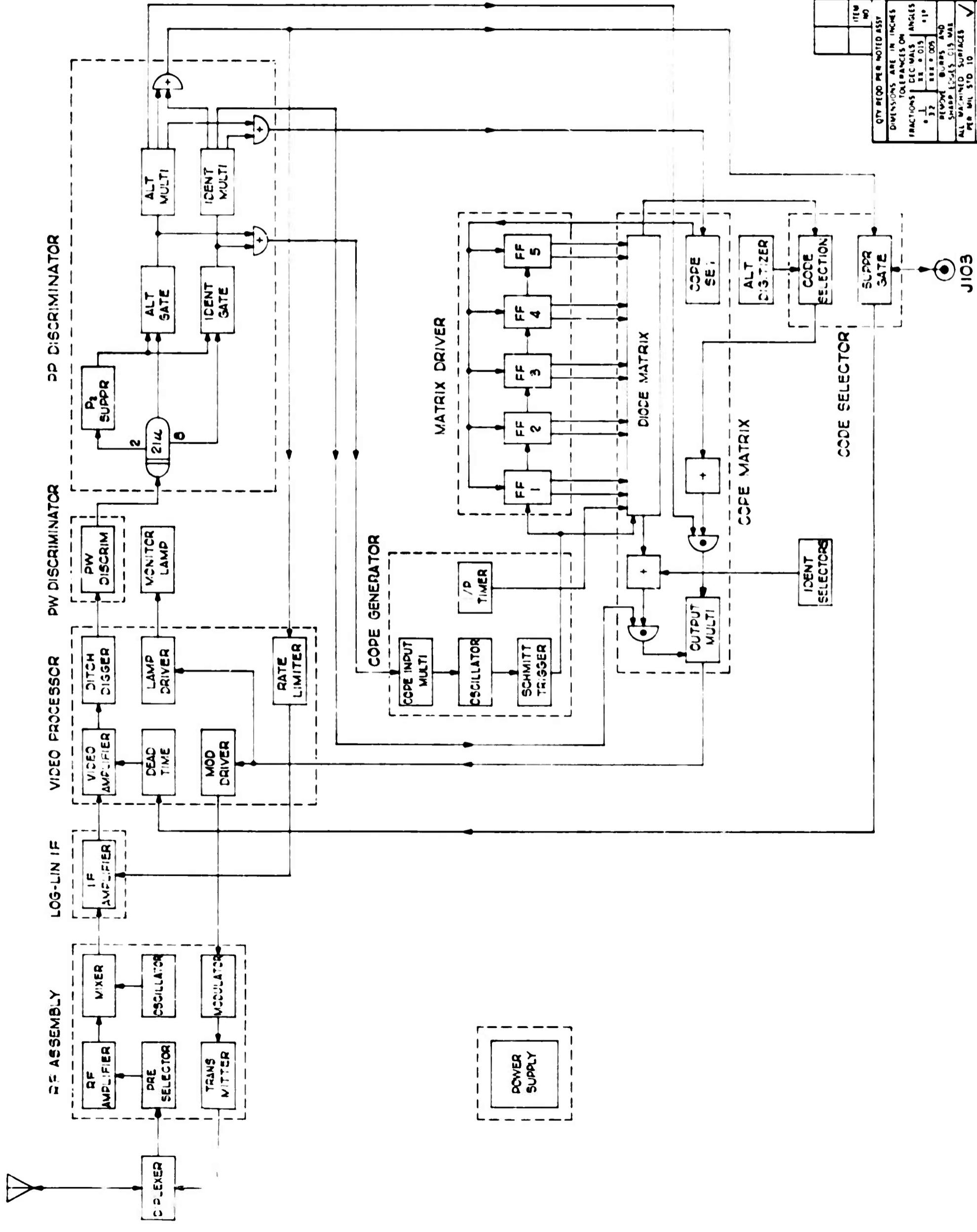

FIGURE 13.

ITEM NO	PART NO	PART DESCRIPTION	MATL SIZE	MATERIAL	MATL SPEC

LIST OF MATERIALS

DATE	2 JAN 50				
DPTSM	2 3 3 5 1 1				
CHECK					
ENGR					
APPR					

QTY REQD PER NOTED ASSY

DIMENSIONS ARE IN INCHES
TOLERANCES ON FRACTIONS DECIMALS ANGLES
 1/16 ±0.015 1/16 ±0.015 1/16 ±0.015

REMOVE BURRS AND SHARP EDGES 0.015 WAVE PER MIL STD 10 ALL MACHINED SURFACES MEET C.M. BEFORE PLATING

FINISH: HEAT TREAT:

CODE IDENT NO 8132 SCALE: D 102D10005

BLOCK DIAGRAM — SLATE III

APPLICATION:

MEAT ASSY NEXT ASSY FINAL ASSY

The outputs from the code matrix are brought out and are connected through individual switching diodes and resistor networks to the +10 VDC source. Connections are brought out from the individual resistor networks to pins on the rear plug. The remote altimeter-digitizer switches the individual resistor networks in such a manner as to remove the bias voltage applied to the switching diodes corresponding to the code selected. These diodes then conduct to provide the pulse at specific time intervals. At the selected time intervals, the pulse appears on a common collector bus from where it is fed through an inverter-amplifier stage in the encoder section to the output monostable. The suppression amplifier provides an approximate 35 μ sec pulse with an amplitude of at least 25 volts. This pulse appears at the microdot connector on the rear panel. The output of the decode monostables also is allied to the dead time circuit to disable the video amplifier during reply transmission.

1.3.13 Altimeter-Digitizer

The altimeter-digitizer is a pressure sensitive device which encodes the reply to the Mode C interrogation. The unit is shown on a drawing, Figure 14. The digitizer contains a series of aneroid capsules connected to a shaft via a special linear to rotary converter. The case is connected to the aircraft static pressure system which feeds the altimeter. As the aircraft climbs, the static pressure is reduced and the sealed aneroid capsules expand, causing the shaft to rotate. A shaft encoder utilizes a disc on which the ICAO altitude code is plated in metallic segments, with nine brush contacts and a common return, plus a dither input. The electrical contacts are brought to a sealed multi-pin connector on the outside of the unit where an interconnecting cable conducts the switch contacts to the transponder for reply pulse selection. The altitude coding employs the A₁, A₂, A₄, B₁, B₂, B₄, C₁, C₂ and C₄ pulses which are selected to feed the "or" gates at the outputs of the diode matrix in the transponder. The reply code is in increments

of 100 feet from -1,000 to +20,000 feet, with respect to a fixed MSL datum of 29.92 in. Hg. The altitude mechanism of the digitizer meets the requirements of TSO C-10b. The barometric adjustment knob affects the pointer display only, not the code.

1.3.14 Modulator and Transmitter

The SLATE transponder transmitter and modulator are shown in Figure 12. The transmitter is a pulsed oscillator operating at 1090 mc/s. Cathode modulation using a single transistor is employed.

The transmitter oscillator is a 5876 pencil triode operating grounded grid in a coaxial cavity. Feedback leads from the cathode cavity to the plate cavity produce sufficient capacitive coupling to sustain oscillations. Loop coupling is used for the output. The modulating transistor is connected in series with the cathode. Positive pulses of approximately 2.0 volts amplitude from the modulator driver turn the transistor modulator on, causing the pencil triode to oscillate. Output pulse power is approximately 300 watts peak.

1.3.15 Power Supply

A power supply is subassembly 200 (Figure 28). All components and wiring on the power supply, except for the power transistors, are contained in a cubicle completely covered by a sealed box for protection. The power supply package is attached to a finned heat sink two inches wide by 3-1/4 inches high which provides adequate dissipation for the power transistors located thereon. The heat sink attaches to the rear panel of the transponder. Utilizing solid state components and a saturable toroid transformer, the unit converts 13.75 VDC to the requirements of the transponder voltages. Power consumption at 13.75 volts is less than 25 watts.

1.4 SLATE TRANSPONDERS - OPERATING CHARACTERISTICS

Data	Weight	Size	Power Input 13.75 vdc	Receiver Frequency	Transmitter Frequency	MTL	Power Output	Mode 3/A Codes	Mode C Codes	Altitude Increments	Altitude Reprtg. Range	Dynamic Range	SLS	Echo Supp'n	Reply Delay	Rate Limiter	Pulse Width Discrim.
SLATE I	3 lb. 15 oz.	3-1/4 x 3-1/4 x 10-1/2	25 W Max.	1030 mc	1090 mc	-65 dbm	20 dbw ±3 db	None	32	500 ft.	-1000' to +14,700'	41 db	3 pulse SLS	Incl.	3.85 µsec	1200	0.8 µs ±0.3
SLATE II	4 lb.	3-1/4 x 3-1/4 x 10-1/2	25 W Max.	1030 mc	1090 mc	-71 dbm	20 dbw ± 3 db	64	32	500 ft.	-1000' to +14,700'	47 db	3 pulse SLS	Incl.	2.5(A) 3.0(C) µsec.	1200	0.8 µs ±0.3
SLATE III	4 lb.	3-1/4 x 3-1/4 x 10-1/2	20 W Max.	1030 mc	1090 mc	-73 dbm	24.8dbw ±3 db	64	512	100 ft.	-1000' to +20,000'	54 db	3 pulse SLS	Incl.	2.6(A) 2.5(C) µsec	1200	0.8 µs ±0.4
SLATE III (MK I)	4 lb.	3-1/4 x 3-1/4 x 12	20 W Max.	1030 mc	1090 mc	-73 dbm	27 dbw ±3 db	4096	512	100 ft.	-1000' to +20,000'	56 db	3 pulse SLS	Incl.	2.7(A) 2.7(A) µsec	1200	0.8 µs ±0.4

2.0 DEVELOPMENT PROBLEM AREAS

2.1 T. R. F. RECEIVER DESIGN

During early stages of development of the SLATE Transponder, experimentation was carried out in the area of multi-stage RF amplifier design using the RCA 8058 nuvistor triode. A four stage amplifier, each stage operating grounded grid, with tuned plate lines, was constructed. This assembly produced 40 db gain, had excellent AGC characteristics and exhibited the required over all selectivity.

A crystal diode detector was then designed, which had a small amount of pulse stretching over the dynamic range, but considered to be within limits. The next development effort was made in the video amplifier design. A five stage amplifier with 60 db gain was constructed. This unit could only handle a 20 db dynamic range without excessive pulse stretching. Several other designs were attempted with little success. (Figure 15).

The TRF approach was abandoned in favor of the superheterodyne, and a log-lin IF amplifier was designed to compress the 50 db dynamic range to a 10:1 output change, with very little pulse stretching.

2.2 VARIOUS TYPES OF ENCODERS AND DECODERS

Decoding methods considered were delay lines, motor magnetics, a series electronic sampling system, and a parallel electronic system to provide multiple decode search pulses. The encoding methods considered were delay lines, motor magnetics, and COPE.

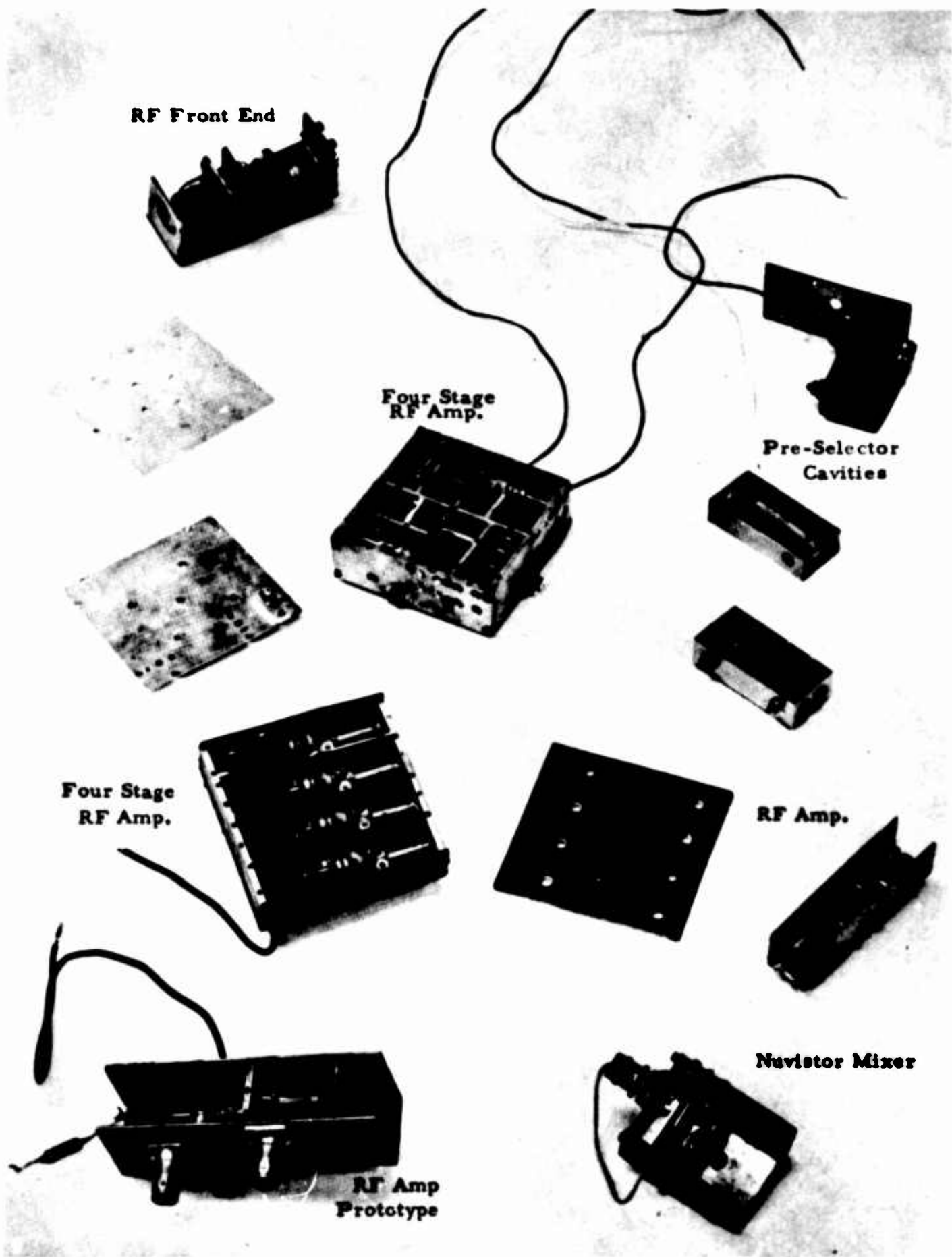

FIG. 15 TRF and FRONT END PROTOTYPES

2.2.1 Decode Search Pulse System

Following is a description of the parallel search pulse means for decoding: (Block Diagram, Figure 16).

Only pulses of proper duration ($0.8 \pm 0.2 \mu\text{sec}$) from pulse discrimination cause this system to function, eliminating the necessity of generating more than a few decode search pulses. Proper pulses trigger flip-flops in counter fashion. The various states of the flip-flops pass through a diode matrix to create isolated triggers corresponding to each proper signal. Each of these segregated triggers fire a pair of monostable multivibrators, one generating 8 and the other 21 μsec duration pulses. Pulses from all the 8 μsec multivibrators are differentiated and added so that their trailing edges can successively trigger a gating multivibrator for coincidence gating in the "identity keyer". The same process with the 21 μsec multivibrators provides successive gating pulses to the "altitude keyer".

Tests proved that incoming proper pulses slightly closer than 2 μsec apart could be handled by this means. The photograph of Figure A shows two signals 2 μsec apart on the bottom trace and the resulting flip-flop action on the top trace. Figures B and C show two separate 21 μsec monostables being triggered one by the downward excursion of the flip-flops and the other by the upward excursion.

Figure D shows the differentiated and added signals from the monostables with the two delayed triggers created at 21 μsec behind each of the two input signals. On a time expanded scale, Fig. E shows the resulting decode search pulses (triggers on the top trace, and decode search pulses on the bottom trace). Figure F shows the two input signals (top trace) and the resulting decode search pulses, each 21 μsec later.

Figures G and H show both the 8 and 21 μ sec delaying pulses being triggered by one state of the flip-flops. Three successive decode search pulses at both the 8 and 21 μ sec delays behind three successive signals are shown in Figures I and J.

Provision could be made for a number of 8 and 21 μ sec search pulses, but with none being wasted on unwanted signals. Four of each would be adequate because they could take care of all three pulses of an unwanted mode mixed in with, or preceding, a wanted mode first pulse and still decode the wanted mode.

2.2.2 Series Decode System

Referring to the block diagram of Figure 17, the series decode system can be seen as a chain of monostable multivibrators. Proper duration pulses from the pulse discrimination circuitry trigger the first monostable repeatedly. The first monostable when triggered is turned on for 1.6 μ sec and then turns off, triggering the second one on for 1.6 μ sec. The second triggers the third, and so on.

Every incoming impulse thus causes the fifth stage to put out a pulse 8.0 to 9.6 μ sec later and the fourteenth stage to put out a pulse 20.8 to 22.4 μ sec later. These two pulses could be fed to the keyers to gate or decode the respective P_3 interrogation pulses coinciding.

2.2.3 Motor Magnetic Delay

Figure 18 shows the associated circuitry required for the decode function of the magnetic delay.

Pulses with acceptable duration would have to be amplified in a record amplifier to feed the first record head or gap. The two impulses,

read out at 8 and 21 μ sec, are individually amplified and trigger two multivibrators which would gate the keyers. Impulses from either the identity or altitude multivibrators, as triggered by either keyer, would be amplified in a mixer amplifier to be recorded on the disc for encoding the corresponding reply at positions on the disc which have had any decoding impulses erased.

2.2.4 Standard Delay Line

Delay lines require very little active circuitry. However, the taps of the line have to be isolated. Figure 19 shows the delay line with its necessary diode gates. These diode gates isolate the taps from being shorted by the video input which is common to all keyers.

2.2.5 Comparisons

There is no question about the reliability and performance of a delay line. Their only minor disadvantages are size and weight. Even these two factors, plus cost, are not serious for a line sufficient to do an adequate job of decoding. A delay line is the lowest cost means for decoding and requires the least power drain for required circuitry, as well as involving the least complexity. Only the more precise line required for encoding is objectionable with regard to size, weight and particularly cost.

The motor magnetics is not the least expensive combination for both decoding and encoding. It has some complexity and would provide poor reliability and life with increased maintenance and objectionable power drain. Its size and weight would be acceptable since it provides both decoding and encoding.

Together with unwanted pulse elimination, the search pulse system provides a unique decoding means that has less weight and size than a delay line, providing acceptable life and reliability with a medium complexity and cost. Similarly, COPE provides the same for encoding.

as well as being the lowest cost means at low power drain.

For ease of comparison, the tabulation below provides a summary of the above.

<u>DECODE</u>	<u>Weight</u>	<u>Size</u>	<u>Power Drain</u>	<u>Life</u>	<u>Reliability</u>	<u>Complexity</u>	<u>Cost</u>
Delay L.	Med.	Med.	Very Low	Excellent	Excellent	Very little	\$ 36.00 (Lowest)
Motor Mag.	Med.	Large	Extreme	Poor	Poor	Med.	150.00 (Med. High)
Search Sys.	Low	Small	Low	Med.	Med.	Med.	62.00 (Med.)
<u>ENCODE</u>							
Delay L.	Very High	Very Large	Very Low	Excellent	Excellent	Very little	\$220.00
Motor Mag.	Med.	Large	Extreme	Poor	Poor	Med.	150.00 (Med. High)
COPE	Low	Small	Low	Med.	Med.	Med.	60.00 (Lowest)

2.2.10 Conclusions

As complete decoding and encoding means, all delay lines would be the most expensive with objectionable weight and size. The motor and magnetics would be acceptable for cost, but life and power drain are objectionable. The very acceptable COPE and Search System provides the least size and weight at lower cost. However, a simple delay line for decoding and COPE for encoding would provide the ideal combination of all features at the lowest possible unit cost in production.

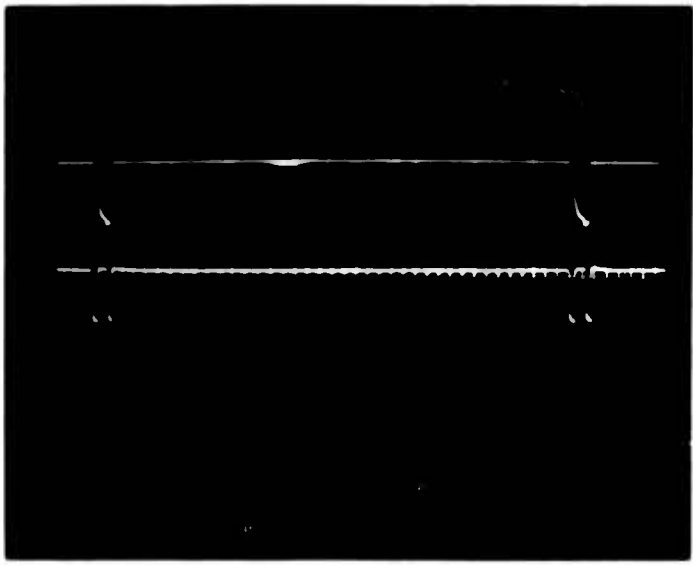

FIG. A

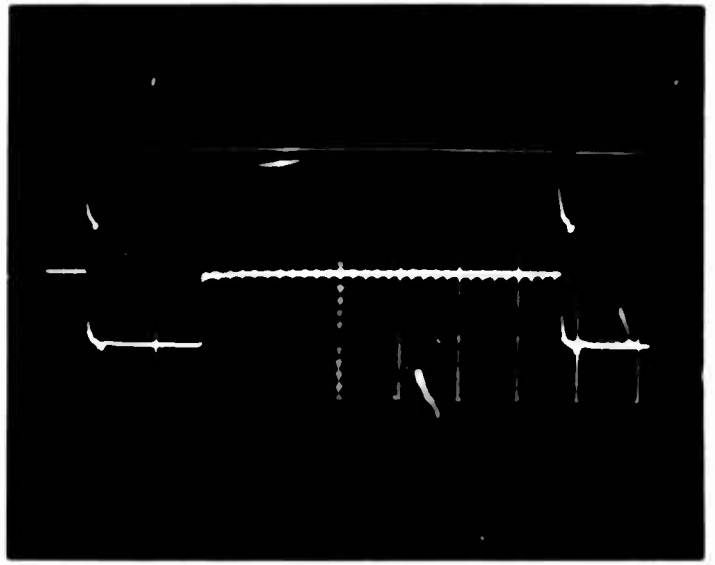

FIG. B

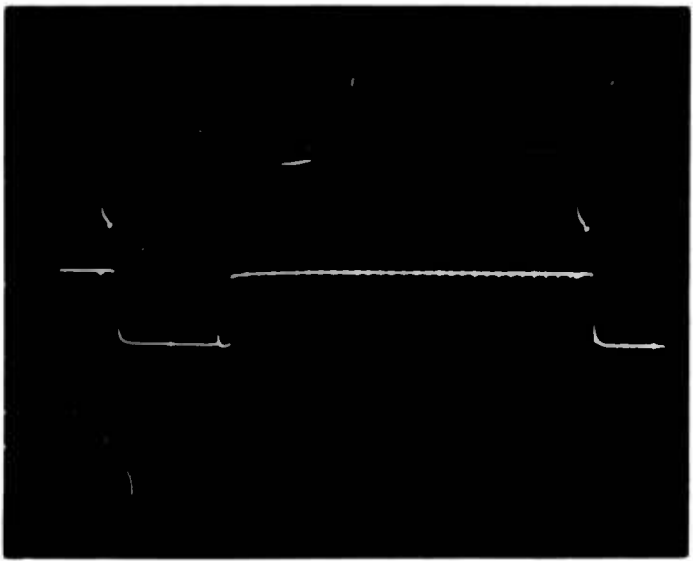

FIG. C

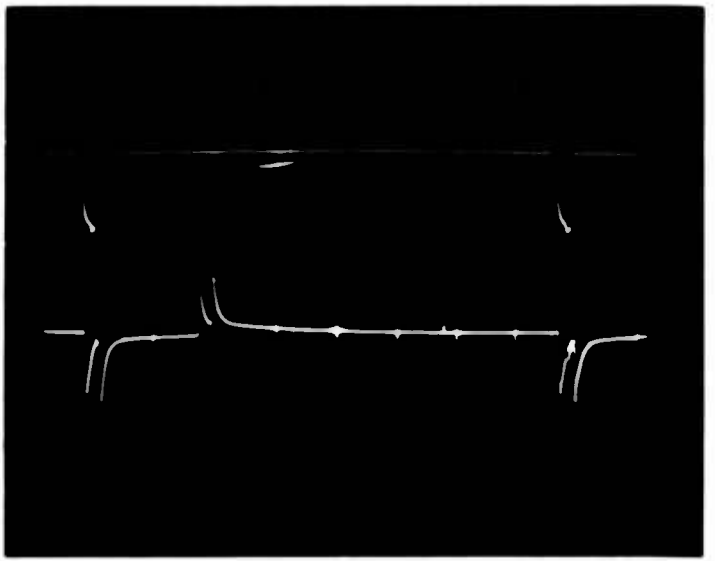

FIG. D

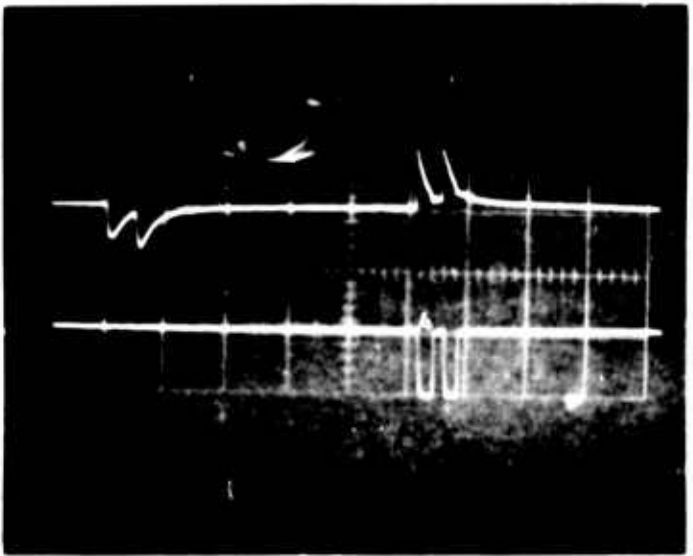

FIG. E

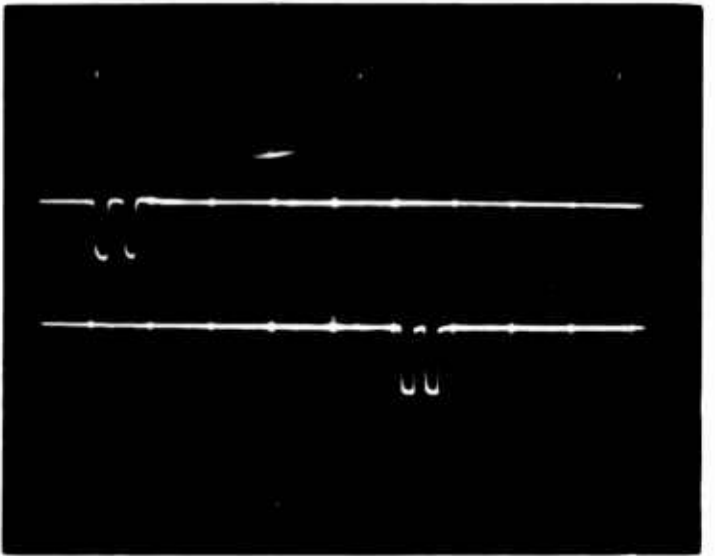

FIG. F

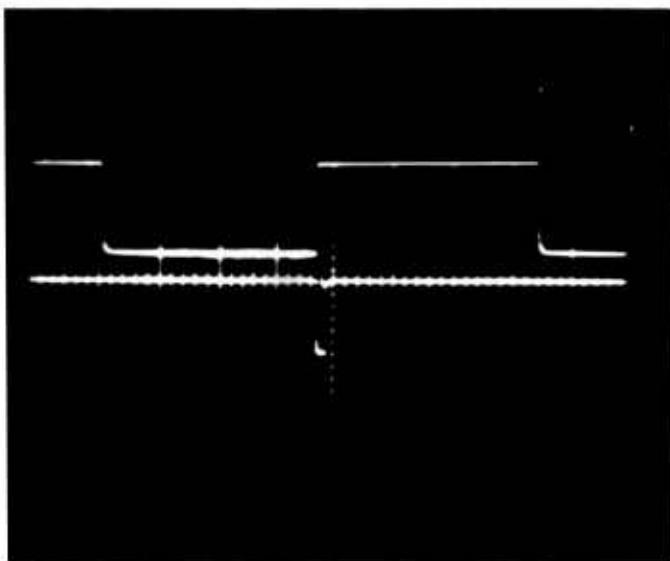

FIG. G

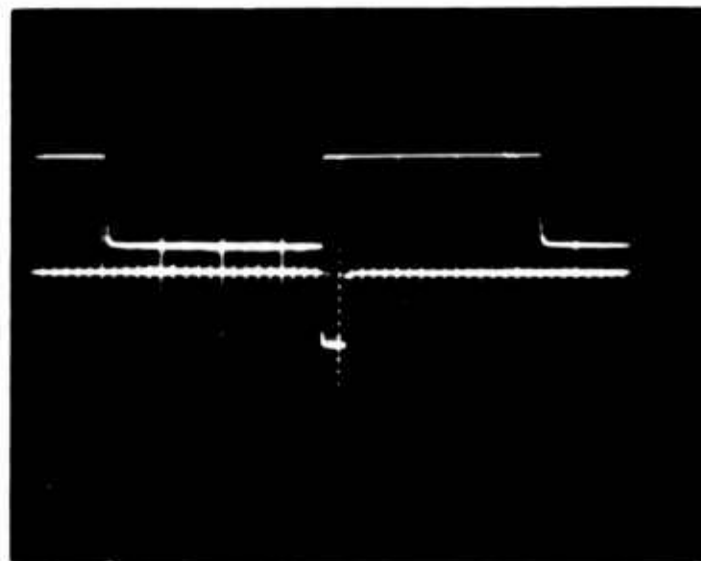

FIG. H

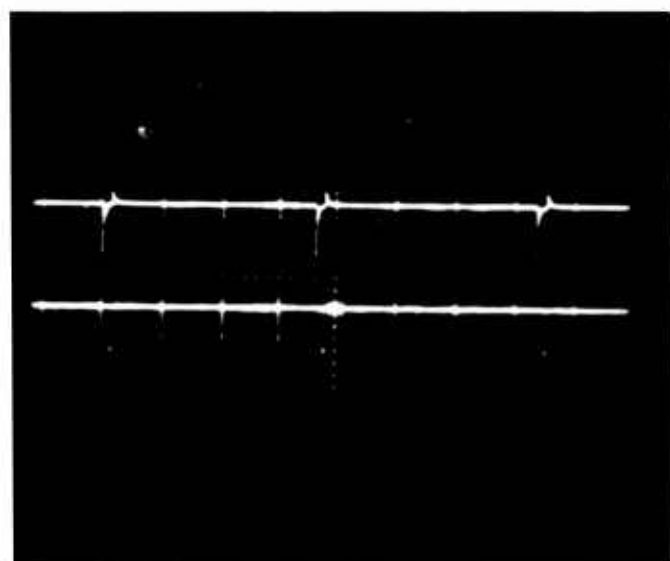

FIG. I

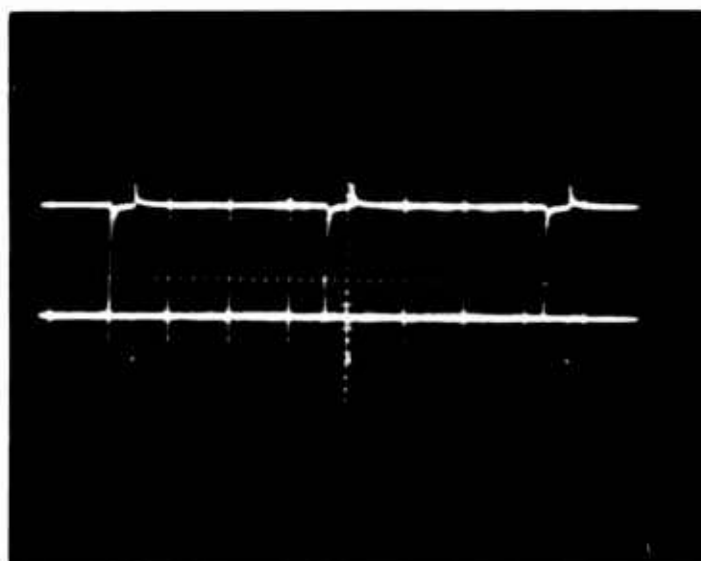
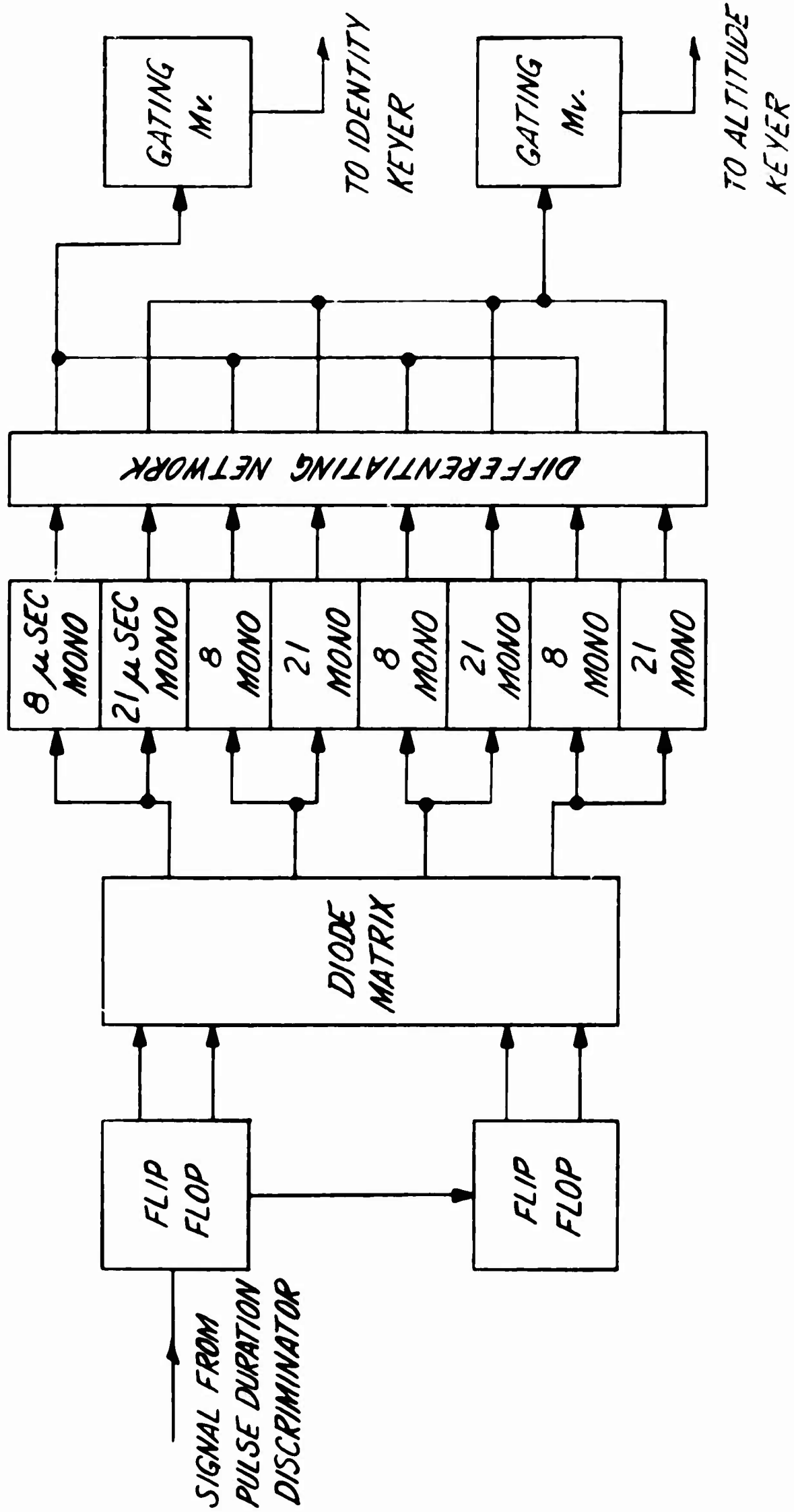

FIG. J

FIGURE 17.



BLOCK DIAGRAM
DECODE SEARCH PULSE SYSTEM

FIGURE 16

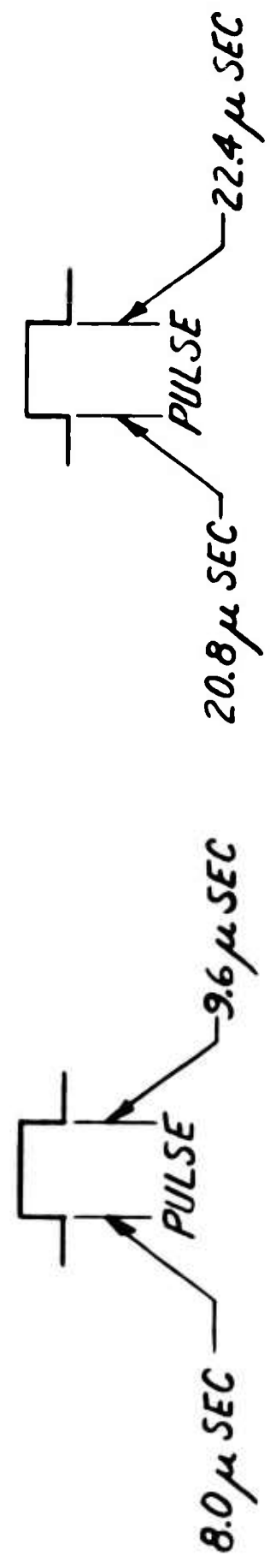
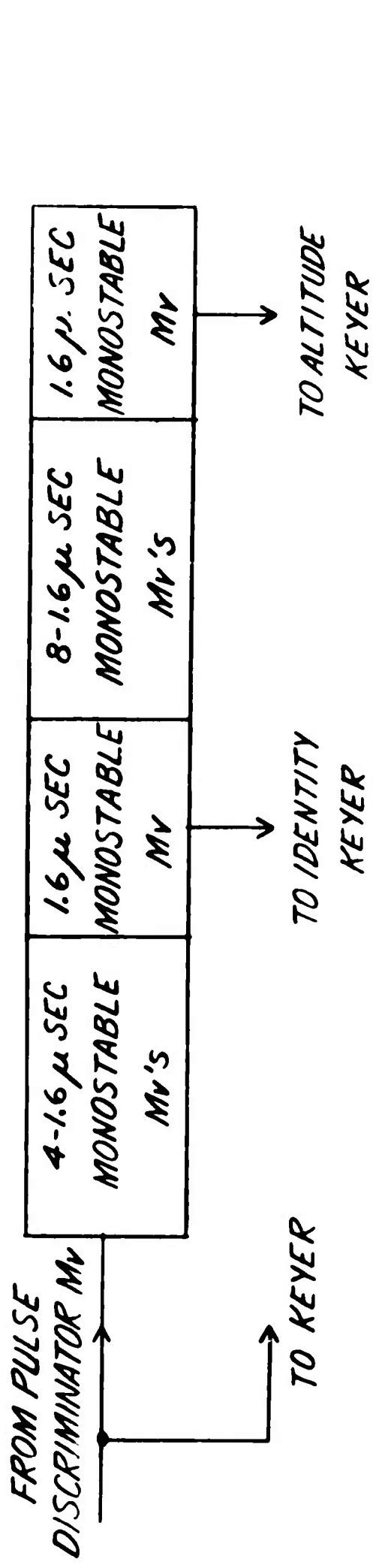
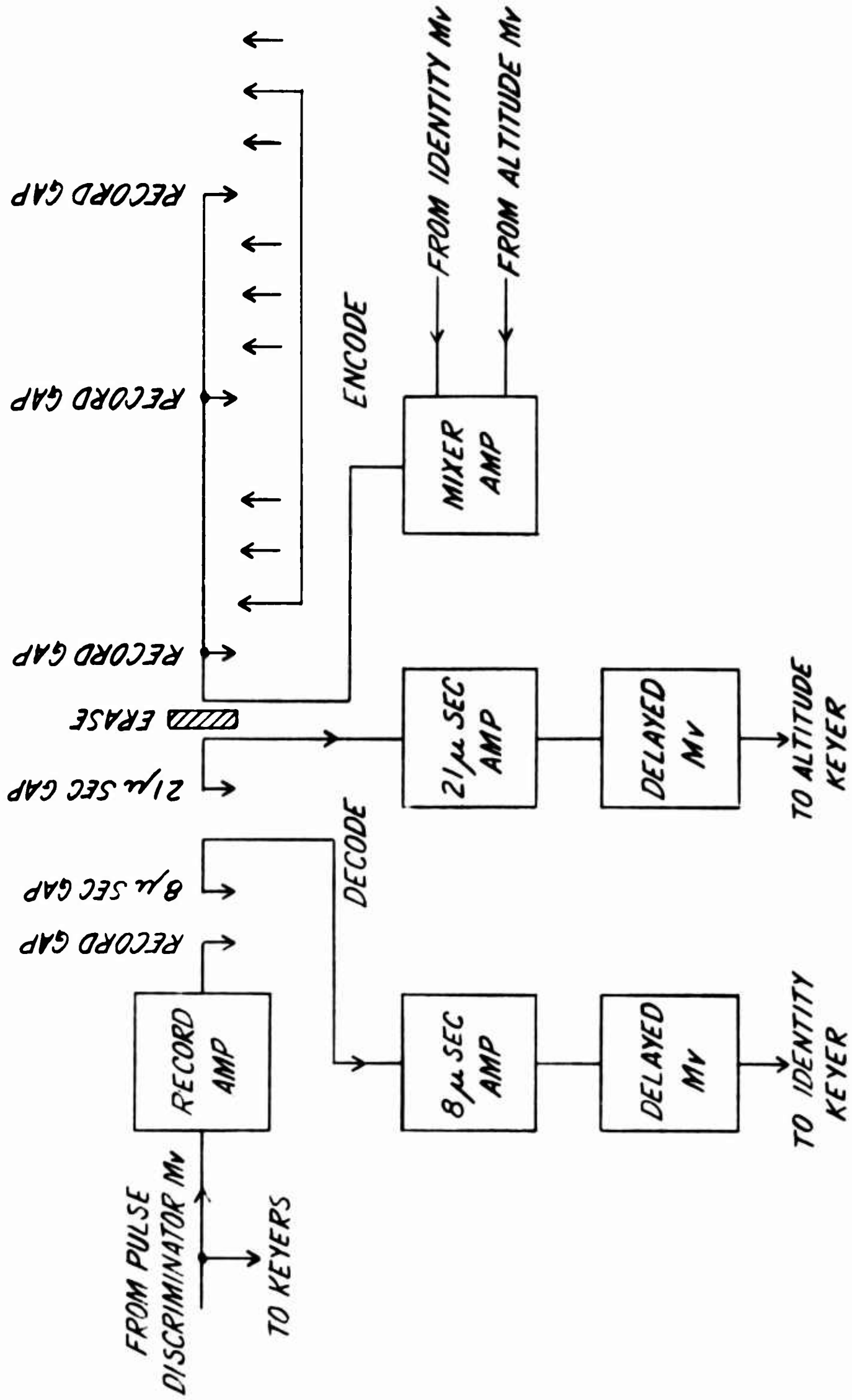
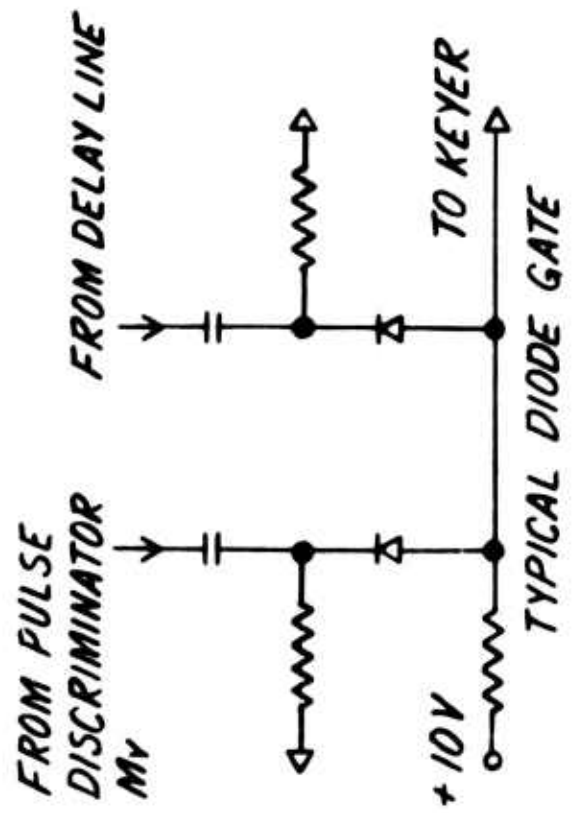
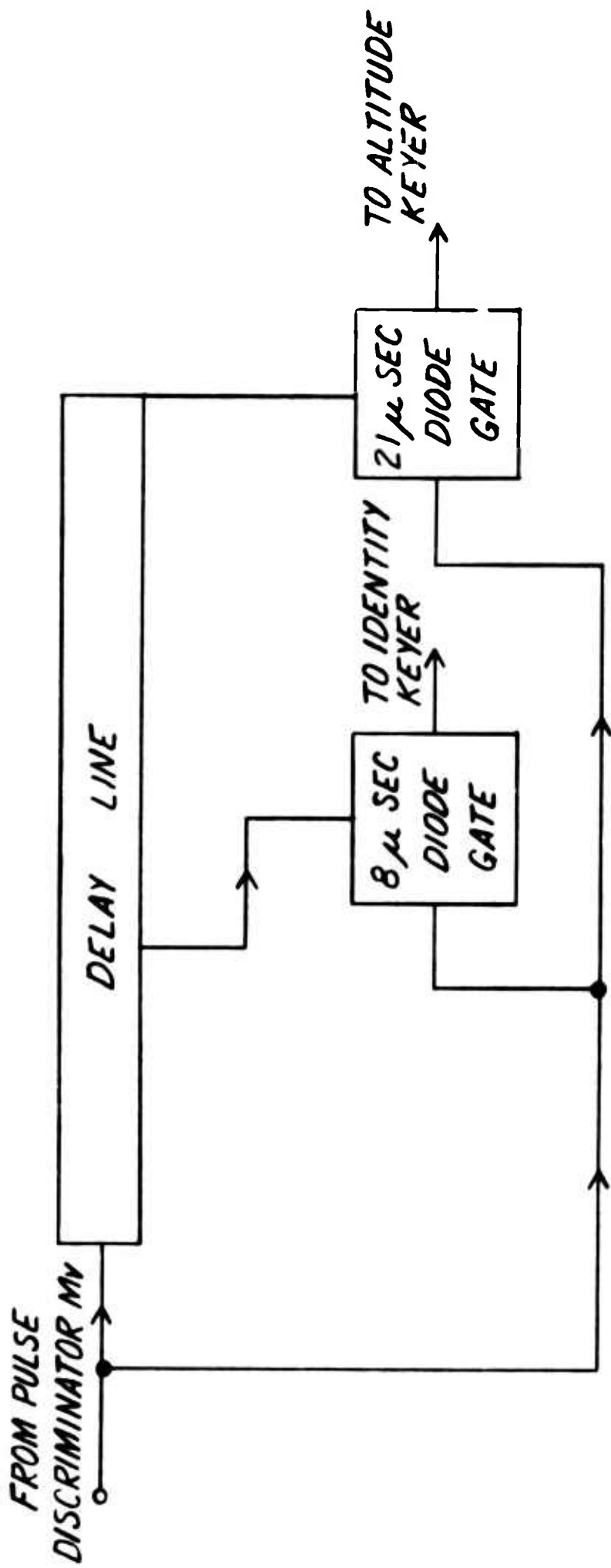

FIGURE 19.



DECODE PORTION OF MOTOR MAGNETICS

FIGURE 18.



DELAY LINE DECODE

2.2.11 Magnetic Drum Encoder/Decoder

The initially proposed method for decoding interrogations and coherently generating replies utilized a motor-driven disc of magnetic material with various record and pickup heads spaced around the periphery.

The motor RPM was to be closely controlled and the heads were spaced in such a manner that a pulse recorded on the disc would be picked up by a particular head delayed by an amount equal to Mode A pulse spacing and on another head for Mode C. This would provide a simple means of mode decoding.

Pulses would be picked up by other heads also, which were arranged at reply pulse spacing for encoding. This system had several disadvantages that were discovered as hardware was fabricated. These were -

1. The motor was very inefficient at 100,000 RPM and required almost 30 watts of drive power.
2. The disc had to be operated in a vacuum to reduce windage.
3. Gyroscopic effect was excessive.
4. Bearing life was very limited.
5. Mylar tape disc was unsatisfactory for recording.
6. Nickel-cobalt coating on the rim of a thin drum produced good recordings but needed more HP.
7. The cost of the precise design was prohibitive.

Transco fabricated nine different motors, over fifty different record/pickup heads, and eight different types of discs before the decision was made to examine another method.

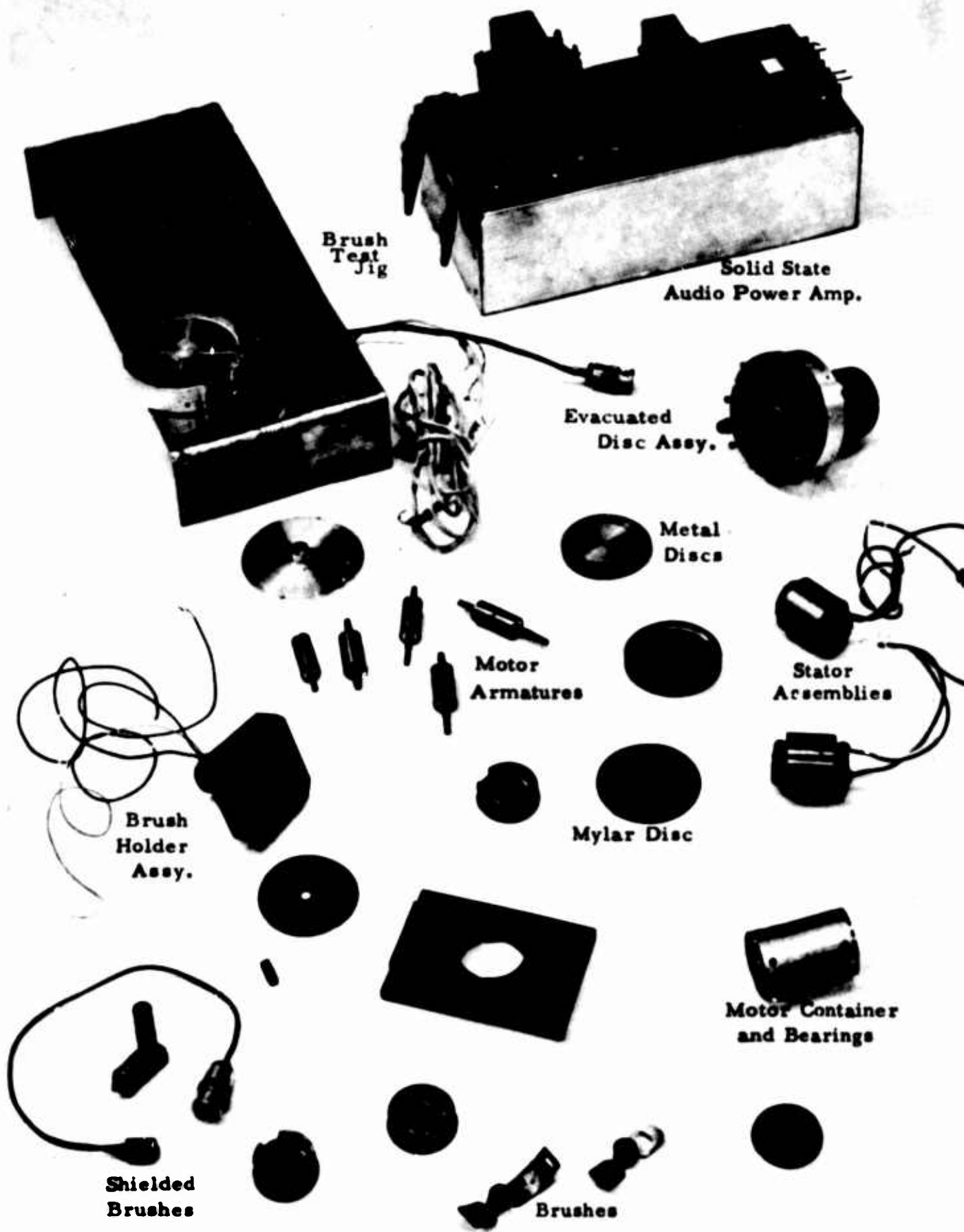

FIG. 20 - MOTOR/MAGNETIC HARDWARE

2.3 SIDE LOBE SUPPRESSION

Two basic problems arose with the video processor and ditch digger sections while the development of SLATE was in progress. Among these was the problem of maintaining a relatively flat top pulse through the video processor in order that the pulse width discriminator might function properly with the interdependence of echo recovery and sidelobe suppression ever present in a series decode system, such as the Transco SLATE incorporates. This then raises a basic problem of differentiation of video pulses.

To obtain a ditch digger action for echo recovery, the pulses, because of a finite rise time, look as though they are much narrower coming out of the squaring circuit. To solve this problem, Transco has developed a delay type ditch digger which does not differentiate the video pulses to any great extent.

The second problem was one of compression in the I. F. amplifier, due to the log-lin characteristics, thereby not allowing enough of a differential in pulse amplitude for the P₂ suppression circuits to operate properly. In order to retain a dynamic range necessary for the transponder, it was deemed necessary to develop a circuit that could distinguish differences in amplitude regardless of the input signal level. This was accomplished in Transco's unique differential comparator which consists of a tunnel diode and a few transistors.

2.4 REMOTE CODE SELECTION

Early in the SLATE III development program, it was necessary to correct a problem of pulse shifting due to the long lead length to the digitizer. To eliminate this problem, a different form of code selecting for Mode C was incorporated. It was found to be completely unwarranted

on the Mode A because of the close proximity of the selector switches. The remote altitude digitizer switches individual resistor networks in such a manner as to remove the bias voltage applied to the switching diodes corresponding to the code selected. These diodes then conduct to provide the pulse of specific time intervals. At the selected time intervals, the pulse appears on a common collector bus from where it is fed through an inverter-amplifier stage in the encoding section to the output monostable.

3.0 CONCLUSIONS AND RECOMMENDATIONS

One primary objective of Contract ARDS-476 was to develop lightweight, low cost transponders suitable for General Aviation aircraft which would be capable of operation in various degrees of reply code capability and altitude reporting increments, so that they could be evaluated operationally in an ATRBS system.

The different versions of the equipment, from the simplest SLATE I up through the sophisticated SLATE III (MK I), have been thoroughly evaluated from a production cost standpoint, and in spite of the significant spread of operational features, the various types exhibit relatively small differences in cost.

Transponders are necessarily complex due to the stringent performance criteria imposed on them by the ATRBS requirements. Whether this degree of complexity is over-severe or not can only be evaluated by those with system responsibility; as the manufacturer of the airborne portion of the data link, we can only speak for the transponder, which is a costly item of airborne equipment.

The SLATE Transponders developed by Transco on this contract are the smallest, lightest and consume less power than any transponders currently available.

Production equipment will cost the consumer approximately five times the figure referred to in the Hough Committee report. A preliminary cost breakdown might appear as follows:

Cost of manufacture	39%
Warranty, profit, sales support	11%
Marketing	50%
Total	100%

It is estimated that the cost of manufacture could be reduced by 20% from 39% to 31% if the specification tolerances were loosened; this, however, is small compared to the cost of marketing, which faces every equipment manufacturer.