

AD610853⁵

STABILITY OF HIGH STRENGTH H₂O₂

QUARTERLY REPORT FOR PERIOD ENDING DEC. 31, 1964

ELECTROCHEMICALS DEPARTMENT
E. I. DU PONT DE NEMOURS & CO.
WILMINGTON, DEL.

COPY <u>2</u> OF <u>3</u>	edj
HARD COPY	\$. 2 . 00
MICROFICHE	\$. 0 . 50

290

CONTRACT NO. AF 04(611)-10216

SPONSORED BY

ADVANCED RESEARCH PROJECTS AGENCY
WASHINGTON 25, D.C.
ARPA ORDER NO. 24

ARCHIVE COPY

DDC
RECEIVED
FEB 10 1965
TISIA E

**BEST
AVAILABLE COPY**

INTRODUCTION

This is the first quarterly report on this program. The experimental work is being carried out in two locations: the Niagara Falls Research Laboratories of the Electrochemicals Department, and the Radiation Physics Laboratory of the Engineering Department, of E. I. du Pont de Nemours and Co. The report is therefore divided into two sections, based on location of the work.

The objectives of this program are stated in the contract as follows:

1. The Contractor shall conduct a research program consisting of the following phases:

a. Determine the inherent bulk stability of pure 90 to 100% hydrogen peroxide at temperatures ranging from -60°F. to $+160^{\circ}\text{F.}$ in the absence of catalyzing surfaces by using solid hydrogen peroxide as the wall.

b. Determine the effect of wall surfaces on the bulk stability as secured above by electron spin resonance and infrared attenuated total reflectance techniques employed on the interface.

c. To subject the pure hydrogen peroxide in contact with a stable surface, if one is found, to radiation to induce instability and thus generate radicals whose interactions with the surface can be determined. The choice and use of the stable surface, if found, will be mutually agreed upon by the procuring activity and the contractor before this phase of study commences.

2. This program shall be directed toward the gathering of information affecting the storability of hydrogen peroxide. Emphasis will lie on the reliability and reproducibility of the data attained.

While "pure" 90-100% hydrogen peroxide was being prepared from commercial 90% material, low temperature storage tests of commercially available (stabilized) 50 and 98% hydrogen peroxide were set up for later comparison with "pure" material. Various methods of heating the central portion of a mass of solid 90-100% hydrogen peroxide are under study by both Departments, and will be reported in the next quarterly report.

Results to date may be summarized as follows:

1. Commercial 90 and 98% hydrogen peroxide, maintained at -60°C . in the solid state, decomposes at a rate of less than 1 ppm per day. As this is the order of magnitude of detection of decomposition in our equipment, we believe that under these conditions high strength hydrogen peroxide can be considered STABLE and STORABLE (less than 0.1% decomposition in 3 years).

2. "Teflon" TFE fluorocarbon film was INERT to 90% hydrogen peroxide for 900 hours at 70°C . There was no evidence of chemical attack on the film, nor any change in its physical properties.

3. The mechanism of chemical attack of 90% hydrogen peroxide on polyethylene films between 50° and 70°C . has been identified, and found to vary, depending upon the structure of the polyethylene.

4. Direct experimental techniques for observation of the decomposition products of hydrogen peroxide ($\cdot\text{OH}$ and $\text{HO}_2\cdot$) have been developed.

Detailed discussion of the experimental program follows.

Section A - Work at Niagara Falls Research Laboratories - A. M. Stock

I. Preparation of Pure Hydrogen Peroxide

Essentially anhydrous hydrogen peroxide was prepared from commercial (Du Pont) 90% hydrogen peroxide by fractional crystallization followed by distillation under reduced pressure. Initial crystallization experiments (3657-6, 3657-7 and 3657-10, Table I) indicated that two or three crystallizations might be necessary to increase the hydrogen peroxide concentration from 90% to 99% or more. However, improvement of the crystallization technique made it possible in most cases to obtain 98-99% H_2O_2 by a single crystallization of the 90% material. (See experiments 3657-12 through 3657-27, Table 1.) In the improved technique, crystallization was carried out in a commercial model freezer at -30°C . instead of in a solid CO_2 ("Dry Ice")-trichloroethylene (Du Pont "Triclene"D) bath (approx. -80°C .). During the filtration step the crystals were blanketed with dry nitrogen and allowed to melt slightly to remove the surface film of mother liquor. Using this technique, large, well-formed crystals were obtained; in one case, the crystals attained a length of approximately 3 inches (See Figure 5).

Distillation was conducted first on a small scale in the apparatus shown schematically in Figure 6. The pressure and water bath temperature were adjusted so that the liquid distilled without ebullition. (See experiment 3657-32, Table 2.) A second distillation (Experiment 3657-64, Table 2) was conducted on a larger scale using the procedure and a modification of the

TABLE I
CRYSTALLIZATION EXPERIMENTS

<u>Experiment Number</u>	<u>Crystallization Procedure</u>	<u>Assay, % H₂O₂</u>		
		<u>Starting Material</u>	<u>After First Crystallization</u>	<u>After Second Crystallization</u>
3657-6	A	90.5	93.6	
3657-7	A	90.5	93.1	
3657-11	A	90.5	93.0	
3657-12	B	90.5	98.2	99.6 ^a
3657-14	B	90.5	99.0	
3657-17A	B	90.5	95.7	99.6 ^a
3657-17B	B	90.5	99.2	
3657-20	B	90.5	98.8	
3657-22	B	90.5	98.2	
3657-23	B	90.5	98.9	
3657-24	B	90.5	98.4	
3657-25	B	90.5	99.8	
3657-26	B	90.5	96.6	
3657-27	B	90.5	96.9	99.6 ^a

^aA composite sample prepared from the indicated lots was recrystallized.

TABLE 2

DISTILLATION EXPERIMENTS

<u>Experiment</u> <u>Number</u>	<u>Sample</u> <u>Weight</u> <u>(g.)</u>	<u>Weights of Fractions, g.</u>			<u>Assay of Fractions, % H₂O₂</u>		
		<u>Forerun</u>	<u>Main</u> <u>Fraction</u>	<u>Residue</u>	<u>Forerun</u>	<u>Main</u> <u>Fraction</u>	<u>Residue</u>
3657-32	178	30	46	97	98.73	99.26	99.86
3657-64	733	-	-	-	97.89	99.27	99.50

apparatus described by Gross and Taylor¹. (See Figure 7 for a schematic drawing of the apparatus.) Both distillations were conducted without the addition of NaOH recommended in the literature^{1,2}; in both cases, a slight increase in H₂O₂ concentration was effected. The conductivity of the distillates will be determined in order to determine the presence of ionic impurities.

II. Rate of Decomposition of Commercial High Strength H₂O₂

The rate of decomposition of commercial high strength hydrogen peroxide (90% H₂O₂ from three manufacturers and 98% H₂O₂ from one manufacturer) was studied at -60°C. The H₂O₂ samples were placed in specially cleaned round bottom "Pyrex" flasks in a modified Revco Model ULT-903 low temperature refrigerator. The flasks were connected to a manometer bank; connections at the mouths of the flask were made with standard taper ground glass joints, each with a narrow ring of silicone lubricant near the top of the joint. Manometers were constructed of 2 mm. "Pyrex" capillary tubing; connecting lines were constructed of 2 mm. "Pyrex" or 4 mm. "Teflon" capillary tubing. Both types of tubing proved satisfactory with "Teflon" offering the advantage of greater flexibility. The manometric fluid was colored kerosene (density = 0.800 g./ml. at 23°C.). A schematic drawing of the apparatus is given in Figure 8. Figure 9 is a detailed drawing of a flask with its outlet assembly.

A leakage problem was encountered during the early stages of the work. At -60°C., the silicone lubricant failed to seal the ground glass joints, even though they were spring-loaded. Satisfactory seals were obtained by "doping" the outside of the joints with sodium silicate solution. When the sodium silicate had thoroughly dried, the joints were tested under both internal and external pressure. All systems except one (which therefore was not used) withstood 59 mm. Hg internal pressure (1000 mm. kerosene, full scale on manometer) and 30 mm. Hg external pressure. During the course of the experiment, the differential between internal and external pressure remained within these limits.

The decomposition rate apparatus was extremely sensitive. A barely detectable pressure change (2 mm. kerosene = 0.12 mm. Hg) was calculated to correspond to decomposition of from 0.10 to 0.14 ppm of the H₂O₂ samples. Theoretically, then, a decomposition of well under 1 ppm over the entire test period should have been detectable. Unfortunately, this small amount of decomposition falls well within the error imposed principally by temperature fluctuations within the refrigerator. At the -60°C. setting, the indicated refrigerator temperature varied from -57.8 to -60.0°C. Since the decomposition flasks are, in effect, immersed in a fluid of low heat capacity (air) with no provision for forced circulation, actual temperature inside the decomposition flasks may vary considerably from the indicated temperature. We have indeed noted that fluctuations in pressure lag considerably behind the corresponding changes in temperature. We estimate the possible error from this source alone to be of the order of 10 ppm.

The decomposition rate data at -60°C . are represented graphically in Figure 10. In this figure the fraction of H_2O_2 decomposed (in ppm) is plotted versus time in days. For each sample, there are two plots; an "incremental" or "rate" plot (broken line) representing the fraction decomposed during each period of 1 or 2 days, and a "cumulative" plot (solid line) representing the fraction decomposed during the entire period of observation to date. In all cases, the "incremental" plots indicated both positive and "negative" decomposition "rates". At the end of the experiment, some samples showed a net positive decomposition, others a net "negative" decomposition. (See "cumulative" plots, Figure 10.) Furthermore, none of the "cumulative" plots gave a clear-cut indication of accumulating decomposition products. We would expect a decomposition rate greater than 1 ppm/day to produce a noticeable upward trend in the cumulative plots. Having observed no such trend, we conclude that at -60°C . all of the commercial high strength H_2O_2 samples tested decompose at this rate or less, if indeed they decompose at all under these conditions.

III. Future Program

After commercial 90 and 98% hydrogen peroxide samples have been tested at -30°C . and 0°C ., tests on "pure" 90 and 99.5% hydrogen peroxide will be repeated at -60°C . and -30°C . in the same type apparatus. Meanwhile, study of methods of securing a "liquid center" in a mass of frozen high strength peroxides will continue, to allow tests to be made under these conditions at 0° , 30° , and 60°C .

EXPERIMENTAL

All glassware used in contact with H_2O_2 was cleaned by the procedure of Shanley and Roth³ which consists of soaking the glassware for 24 hours in 10% NaOH, rinsing with distilled water, soaking for 24 hours in 10% HNO_3 , then for 48-72 hours in concentrated HNO_3 , rinsing thoroughly with distilled water, then with "deionized" water and finally drying in a forced draft oven at 125°C .

Crystallization of H_2O_2

Procedure A

The sample to be crystallized was placed in a beaker of appropriate size, which was then immersed in a solid CO_2 ("Dry Ice") trichloroethylene (Du Pont "Triclene" D) bath until the H_2O_2 froze. The solid H_2O_2 was collected on a sintered glass funnel (a clean stainless steel spatula was used to remove the crystals from the beaker) and allowed to melt slightly. The melted H_2O_2 was drawn off and the crystals transferred to a clean glass bottle with a vented aluminum screw cap. The bottle was covered loosely with a polyethylene bag to exclude moisture and stored in a freezer maintained at ca. -30°C .

Procedure B

The H₂O₂ sample was cooled in a freezer kept at about -30°C. If crystallization had not set in by the time the sample reached thermal equilibrium, the liquid was seeded with a few H₂O₂ crystals. After the onset of crystallization, the sample was left in the freezer overnight. The crystals were collected as in Procedure A except that a stream of dry nitrogen was blown over the funnel during filtration.

Small Scale Distillation

The apparatus was assembled as shown in Figure 6, and 178 g. of ca. 98% H₂O₂ placed in the still pot. Distillation was carried out at a pressure of ca. 1 mm. Hg. The water bath was maintained at 35-43°C. so that the H₂O₂ distilled without ebullition. The temperature at the still head was 26-28°C. Initially, both receivers were cooled in solid CO₂-trichloroethylene baths. However, the forerun receiver became plugged with solid H₂O₂, making it necessary to interrupt the distillation and allow the distillate to melt. When distillation was resumed, collection of the second fraction was begun with the receiver immersed in an ice-NaCl bath (-10°C.). The receiver containing the previously collected forerun was immersed in a solid CO₂-trichloroethylene bath. The results of the distillation are given in Table 2.

Large-Scale Distillation

The apparatus was assembled as in Figure 7 and 733 g. of approx. 98% H₂O₂ charged to the still pot (A). A small quantity of ice was placed in the first trap (D) to dilute any H₂O₂ reaching this point. The still pot (A) and first receiver (B) were immersed in water baths kept at 35-40°C.; the second receiver (C) and traps (D and E) were immersed in solid CO₂-trichloroethylene baths. Distillation was carried out under the same conditions as in the small-scale operation, the forerun being collected in the second receiver (C). The first receiver (B) was then cooled to -5° to -10°C. with an ice-NaCl bath and the second fraction collected in it. Results of the distillation are summarized in Table 2.

Assay of H₂O₂ Samples

Hydrogen peroxide samples were assayed by titration with standard KMnO₄ in the presence of excess H₂SO₄.

Decomposition Rates

The total volume of each decomposition flask and head assembly (Figure 9) was determined by weighing the contained water, taking into account the overlap of the ground glass joint. (Density of water was taken to be 1.00 g./ml.) The volume of the connecting tubing was calculated from the weight of water contained in a known length of the tubing. The total volume of

each assembly (V_a) was obtained by summation of the volumes of its components. Approximately 500 ml. of H_2O_2 was placed in each flask and weighed by difference. The flasks were placed in the refrigerator, fitted with their head assemblies, connected to the differential manometers, and (after considerable difficulty) sealed. The refrigerator was set to the desired temperature and started; the manometer stopcocks were left open until the refrigerator commenced cyclic operation. The manometer stopcocks were closed, the refrigerator stopped and opened, allowing the temperature to rise. The pressure in each assembly was allowed to rise until the manometer reached full scale, then the assembly was vented. All assemblies except #9 survived this pressure test. The systems were again closed and the refrigerator started until the manometers indicated a vacuum of at least 500 mm. kerosene (ca 30 mm. Hg); all assemblies (except the unused #9) also passed the vacuum test. The systems were again vented, then closed again after several hours. A pressure reading was taken shortly after the system was closed and at approximately daily intervals thereafter for the duration of the experiment. Data recorded were (1) date and time of reading, (2) room temperature in $^{\circ}K$, (3) refrigerator temperature (T) in $^{\circ}K$, (4) barometric pressure (P_e) in mm. Hg, (5) height of kerosene in left arm of manometer (h_l) in mm., and (6) height of kerosene in right arm of manometer (h_r) in mm. (The left arm of each manometer was open to the atmosphere and the right arm connected to the appropriate decomposition flask.) From these data were calculated the total pressure (P_1) in each decomposition assembly (equation 2), the apparent partial pressure of oxygen evolved by decomposition of H_2O_2 (equation 4) and the apparent fraction of H_2O_2 decomposed (equation 9 or 10).

Method of Calculation

Let P_e = barometric pressure in mm. Hg

" h_l = height of kerosene in left (atmosphere) arm of manometer

h_r = height of kerosene in right (assembly) arm of manometer

ΔP = difference in pressure (mm. Hg) between exterior and interior of assembly

P_1 = pressure (mm. Hg) inside assembly

(Equation 1) $P_1 = P_e + \Delta P$

(If $P_1 > P_e$, ΔP is positive; if $P_1 < P_e$, ΔP is negative.)

Taking density of kerosene = 0.800 and density of Hg. = 13.546,

$$\Delta P = \frac{0.800}{13.546} (h_l - h_r) = 0.059 (h_l - h_r)$$

Therefore,

$$(Equation 2) \quad P_i = P_e + 0.059 (h_l - h_r)$$

Let P_o = partial pressure (mm. Hg) of evolved oxygen at standard temperature (273.2°K.)

P_t^* = pressure (mm. Hg) inside assembly at time t, corrected to standard temperature

P_o^* = pressure (mm. Hg) inside assembly at time o (arbitrarily chosen) corrected to standard temperature.

T_t = refrigerator temperature at time t.

T_o = " " " " o.

$$(Equation 3) \quad P_o = P_t^* - P_o^*$$

$$\text{where } P_t^* = P_i(t) \frac{273.2}{T_t}$$

$$\text{and } P_o^* = P_i(o) \frac{273.2}{T_o}$$

Therefore,

$$(Equation 4) \quad P_o = P_i(t) \left(\frac{273.2}{T_t} \right) - P_i(o) \left(\frac{273.2}{T_o} \right)$$

Let V_f = free volume of assembly in ml.

V_t = total " " " " "

V_s = volume of H_2O_2 sample (ml.) under experimental conditions

$$(Equation 5) \quad V_f = V_t - V_s$$

$V_s = W_s/d_s$ where W_s is the sample weight (g.) and d_s is the density (g./ml.) of the sample

Therefore,

$$(Equation 6) \quad V_f = V_t - W_s/d_s$$

Assuming $d_s = n_h d_h + n_w d_w = 1.71 n_h + 0.915 n_w$

where n_h and n_w are the weight fractions of H_2O_2 and water, respectively

d_h and d_w are the densities (g./ml.) of solid H_2O_2 and ice, respectively

Then

$$\text{(Equation 7)} \quad V_f = V_t - W_s / (1.71 n_h + 0.915 n_w)$$

Let F = fraction (in ppm) of H₂O₂ sample decomposed

M_o = moles O₂ evolved

" M_h = " H₂O₂ in original sample

" V_{stp} = volume of O₂ evolved at standard temperature (273.2°K) and pressure (760 mm. Hg)



$$\text{(Equation 8)} \quad F = \frac{2M_o}{M_h} \times 10^6$$

Since M_h = n_hW_s/34.02 (34.02 = gram molecular weight of H₂O₂)

and M_o = V_{stp}/22,400 (22,400 = gram molar volume of O₂ in ml.,

where V_{stp} = V_f (P_o / 760.C) = V_fP_o / 760.0

$$M_o = V_f P_o / (760.0)(22,400) = V_f P_o / 1.702 \times 10^7$$

By substitution

$$\text{(Equation 9)} \quad F = \frac{2(34.02)(10^6)V_f P_o}{(1.702)(10^7)n_h W_s} = \frac{68.04 V_f P_o}{17.02 n_h W_s} = \frac{3.997 V_f P_o}{n_h W_s}$$

By collecting constants

$$\text{(Equation 10)} \quad F = K_{P_o}$$

where

$$K = \frac{3.997 P_o}{n_h W_s}$$

- NOTES:
1. Equation 8 assumes that the decomposition rate is so small that the H₂O₂ concentration remains constant, i.e., the decomposition reaction is pseudo zero order in H₂O₂.
 2. The entire volume of gas was assumed to be at refrigerator temperature, although the gas in the capillary tubing (ca. 3% of the total) was at room temperature (293.7-297.7°K) during the experiment. We would expect only a relatively small error in oxygen partial pressure from this assumption.
 3. No correction for oxygen solubility in solid H₂O₂.

REFERENCES

1. P. M. Gross, Jr. and R. C. Taylor, J. Am. Chem. Soc., 72, 2075 (1950).
2. R. C. Young, "Specific Conductivity of Hydrogen Peroxide Solutions", Report No. 4, Navy Bureau of Ordnance, Contract No. NOrd-9107, Task C, Massachusetts Institute of Technology, Division of Industrial Cooperation, Feb. 28, 1946.
3. E. M. Roth, Jr. and E. S. Shanley, Ind. Eng. Chem 45, 2343 (1953).

Section B - Work at Radiation Physics Laboratory,
Wilmington, Del.

- J. P. Paris

I. Polymer Surface Studies

In many applications, such as vents, filters, and even containers, "inert" polymeric materials are often in contact with high-strength hydrogen peroxide. The purpose of this part of our work is to investigate the application of attenuated total reflectance spectroscopy to the determination of the stability of various polymers in the presence of high-strength hydrogen peroxide.

a. Experimental Technique

A Wilks Model 12 double-beam attenuated total reflectance (ATR) attachment (shown in Figure 1) for the Perkin-Elmer 221 infrared spectrophotometer was used for all ATR spectra taken. The internal reflector plates used are made of 2-mm thick KRS-5, which have about 25 reflections along the sample path. Each surface reflection penetrates the sample a few microns, providing a very sensitive sampling technique for changes in surface structure.

The samples used were 1-5 mils thick and 20 x 50 mm. in area to match the size of the KRS-5 plate. As shown in Figure 2, these samples are sandwiched between stainless-steel pressure plates and the KRS-5 plate to ensure intimate contact of the sample surfaces with those of the KRS-5.

b. Results

The rate of oxidation of polyethylene films by 90% hydrogen peroxide has been studied at 50 and 70°C. by following the growth of the C-O bands (1050 and 1000 cm^{-1}), C=O bands (1710 and 1640 cm^{-1}) and O-H bands (broad absorption at 3300 and 3400 cm^{-1}). The "Teflon" holders for the

polymer samples and constant temperature baths are shown in Figure 3. It was found that the rate of surface oxidation at 70°C. was approximately twice that found at 50°C. After 500 hours exposure at 70°C., a scale formed on the surface of the polyethylene which transferred to the KRS-5 reflector plate on contact thus restricting further analysis.

A similar study was performed on "Teflon" TFE fluorocarbon film which is known to be very stable toward hydrogen peroxide but has been reported to "bleach". Intermittent analysis of the surface of "Teflon" up to 900 hours at 70°C. showed no indication of chemical attack or change in physical properties.

II. Aluminum Surface Studies

Aluminum has attained a prominence in the high-strength peroxide container due to its "passive" surface structure. Ultimate stability of hydrogen peroxide may depend on ultimate passivation.

a. Results

Numerous studies have been reported in the literature concerning the structure of the oxidized and hydrated amorphous and/or crystalline regions found on aluminum surfaces. However, there appears to be no definitive analysis of the normally "passivated" aluminum surfaces using nitric acid and steam treatments followed by exposure to hydrogen peroxide.

It was expected that the passivation process formed a continuous protective oxide coating which could easily be studied by electron microscopy. The technique for stripping the film consists of dissolving away the unoxidized portion of the aluminum with a solution of bromine in methanol. When the procedure was applied to a sample of aluminum 1060 which was exposed to 35% nitric acid for 1 hour followed by a steam treatment for 1/2 hour, only small discontinuous oxide fragments were isolated.

The behavior of the passivated aluminum surface differs markedly from that for an untreated sample which has a continuous 100-200 Å oxide coating which can be conveniently stripped. The porous, discontinuous nature of the passivated surface suggests that pitting of certain aluminum containers may start in the weak regions in the oxide coating.

Single crystals of 99.995 Al and 99.5% Al doped with 0.5% Cr were exposed to 90% hydrogen peroxide for 40 hours at 80°C. to form an oxide coating. Stripping the aluminum resulted in no observable surface layer. It is possible that the oxide surface is dissolved at about the same rate it is formed and that those pores formed are automatically sealed by the hot peroxide solution.

III. EPR Studies

Chain reactions involving transition metal ions and hydrogen peroxide are responsible for the catalytic decomposition reactions. The free radical carriers of this chain can be followed by their electron paramagnetic resonance spectra.

a. Experimental Technique

A flow system, shown in Figure 4, has been constructed for rapid mixing (~ 1 msec) of two solutions at the entrance to the EPR cavity. The reactants are pressurized at 10 psi using Argon which gives a resultant flow of about 1 liter per minute of solution through the mixing chamber. A commercially available mixing chamber constructed out of "Lucite" acrylic resin provided efficient mixing but was attacked by the hydrogen peroxide after a few runs.

The flow system employs two reactant entry ports through "Teflon" capillary tubes into a "Teflon" mixing chamber. Although the system constructed of "Teflon" is inert to the reactants, the cylindrical design causes the signal-to-noise ratio to be about an order of magnitude lower than that for a flat cell construction. Negotiations are under way to obtain a quartz reaction cell to maximize both the stability and sensitivity of the instrument.

b. Results of EPR Transients from Hydrogen Peroxide

The general reaction steps in the catalytic decomposition of hydrogen peroxide are well known but each individual rate constant is difficult to determine because of competitive reactions. Part of this problem is being avoided by independently generating hydroxyl and perhydroxyl radicals using the reaction between titanous chloride and hydrogen peroxide:

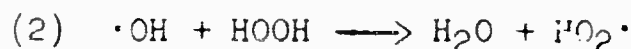

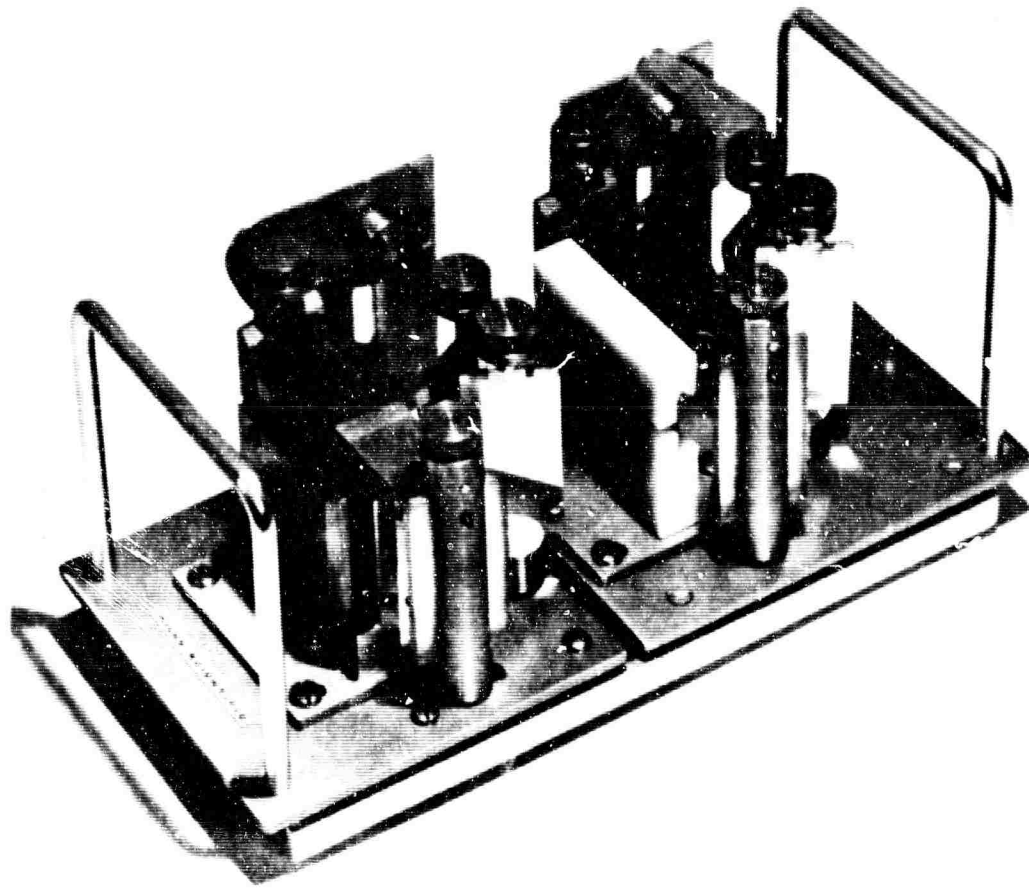

FIGURE 1

ATTENUATED TOTAL REFLECTANCE OPTICAL SYSTEM

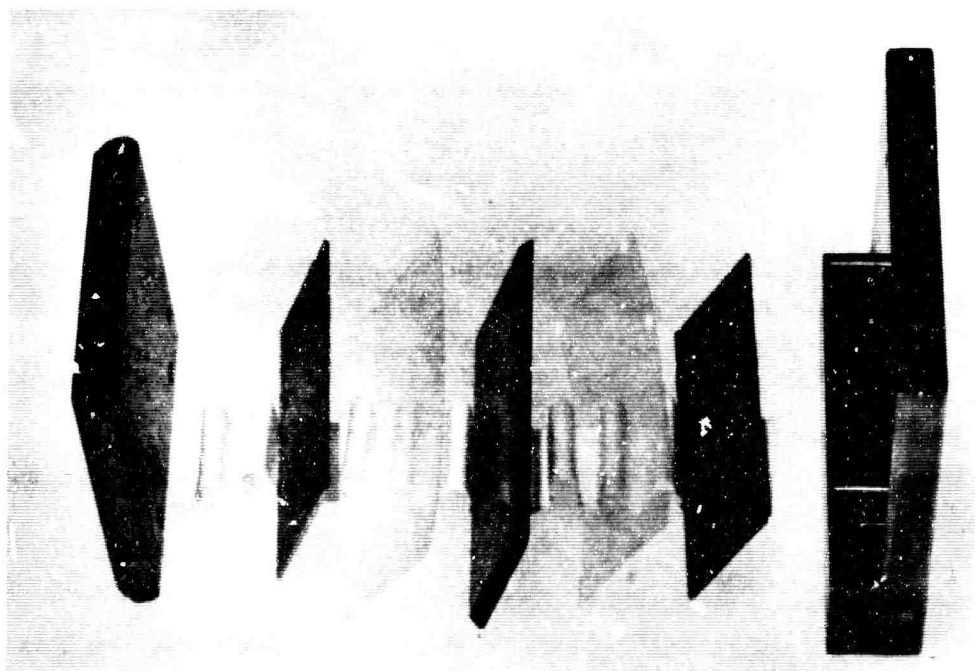

FIGURE 2

EXPLODED VIEW OF SAMPLE HOLDER FOR ATR

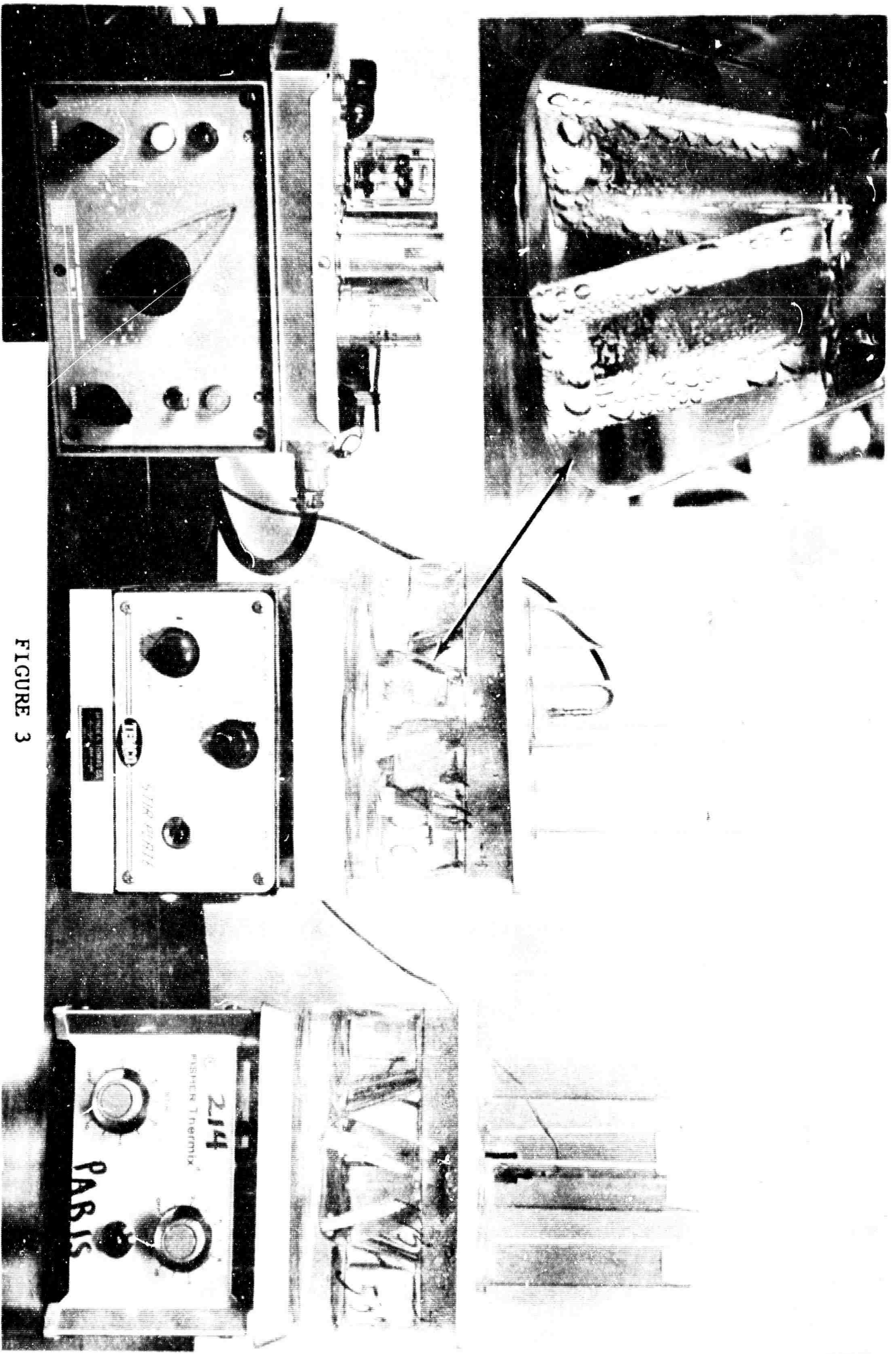

FIGURE 3

CONSTANT TEMPERATURE BATHS FOR HYDROGEN PEROXIDE
ATTACK ON POLYMERS FILMS

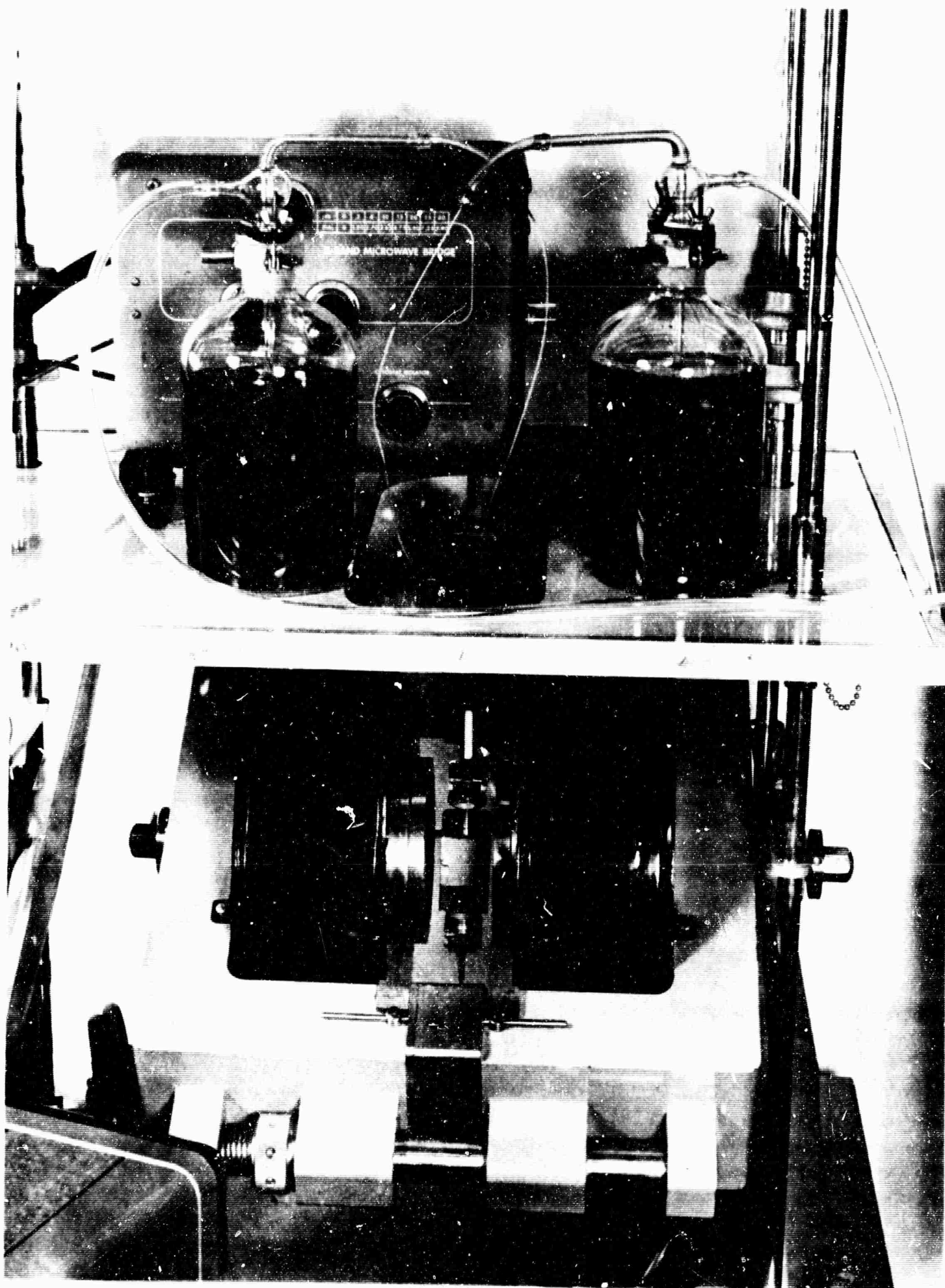
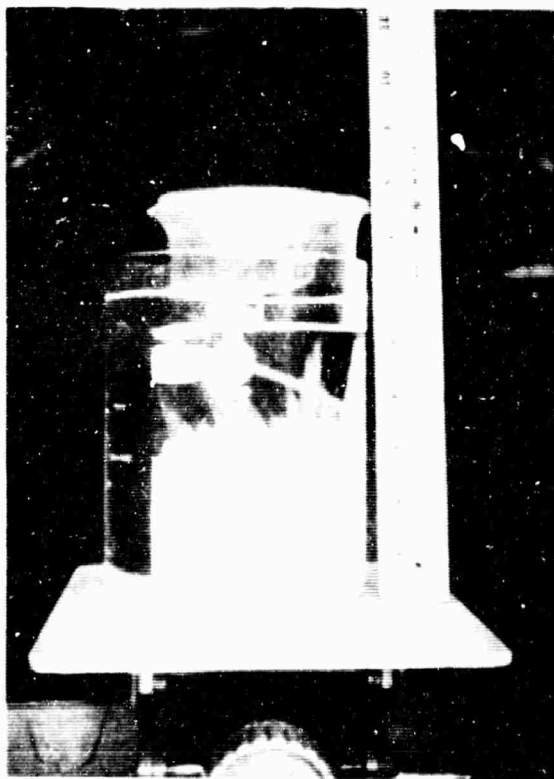

FIGURE 4

"TEFLON" FLOW SYSTEM THROUGH AN EPR CAVITY

FIGURE 5



HYDROGEN PEROXIDE CRYSTALS

FIGURE 6
SMALL SCALE DISTILLATION APPARATUS

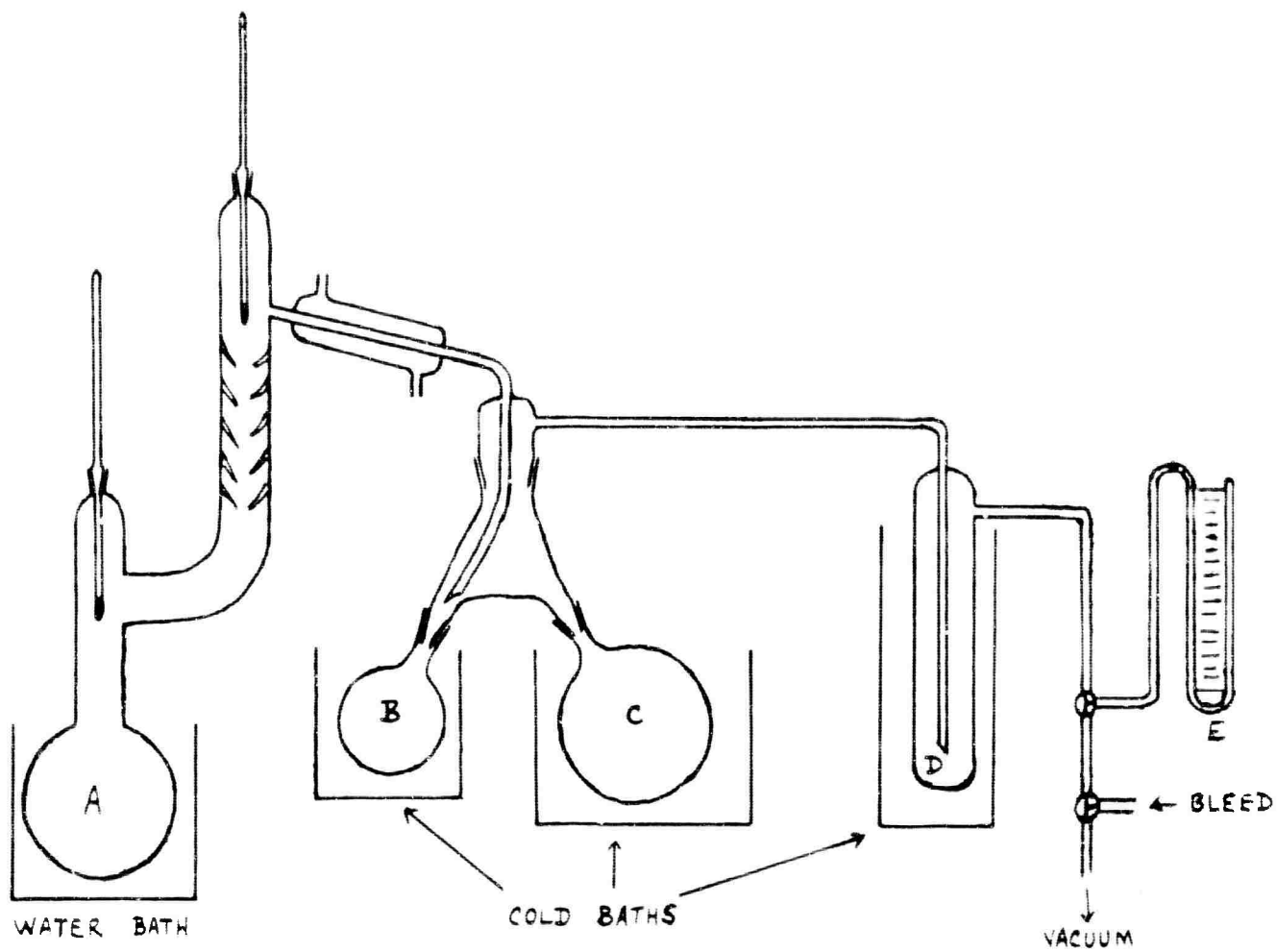

A - POT
B - FORERUN RECEIVER
C - MAIN PRODUCT RECEIVER

D - TRAP
E - MANOMETER

FIGURE 7
LARGE SCALE DISTILLATION APPARATUS

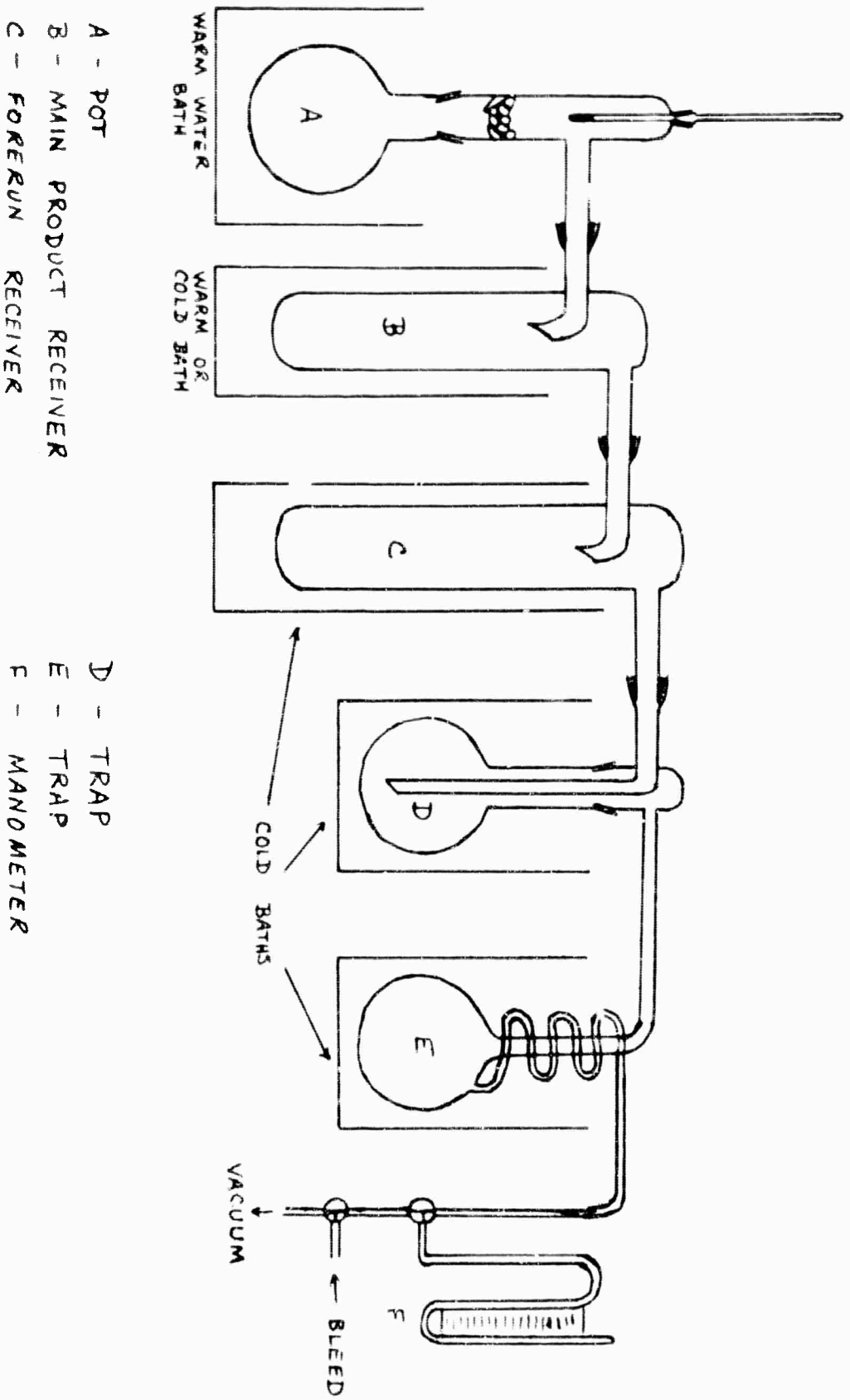

A - POT
B - MAIN PRODUCT RECEIVER
C - FORERUN RECEIVER

D - TRAP
E - TRAP
F - MANDOMETER

FIGURE 8
DECOMPOSITION RATE APPARATUS
(SCHEMATIC)

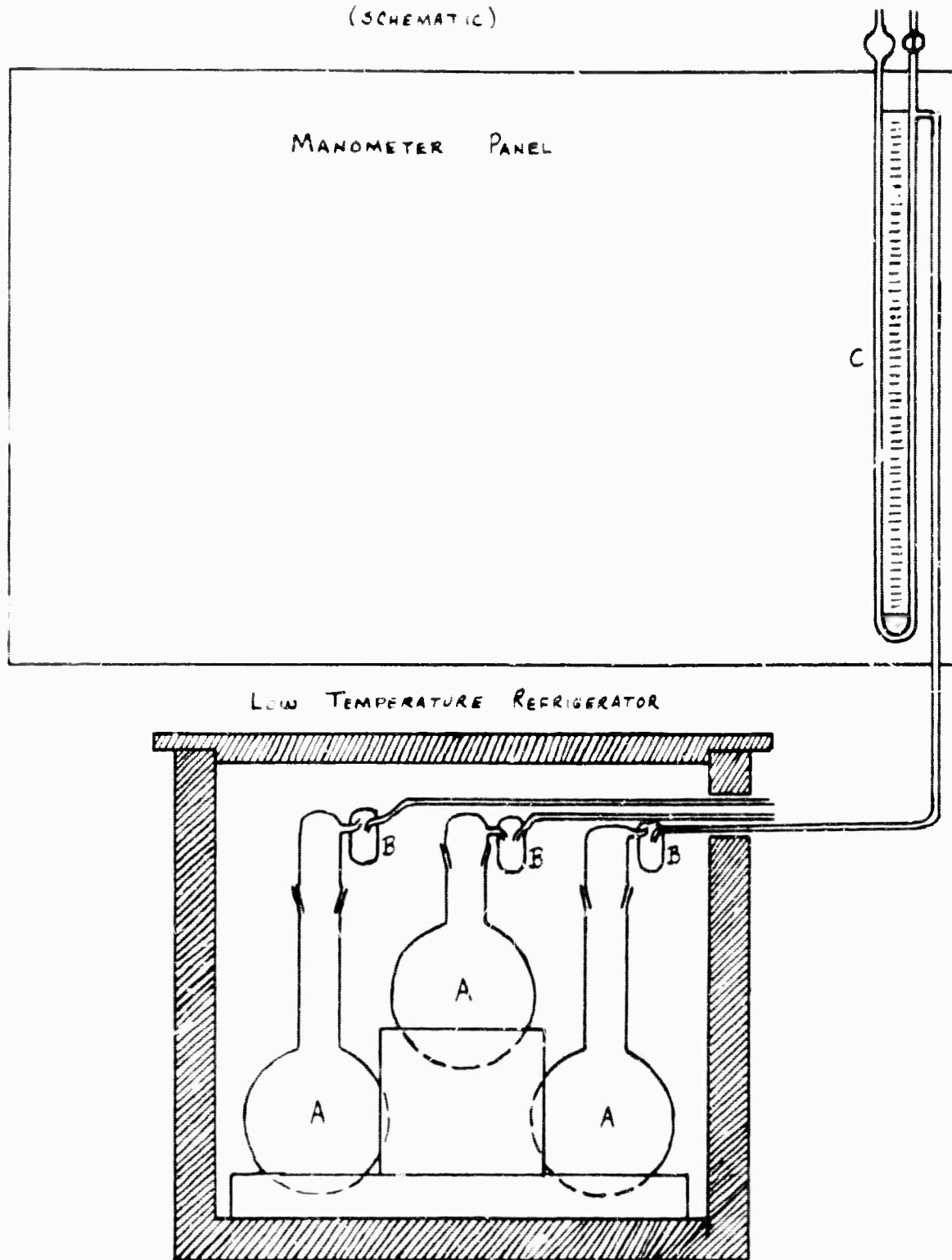

A- DECOMPOSITION FLASKS (3 OF 12 SHOWN) B- KEROSENE TRAPS (3 OF 12 SHOWN)
C- KEROSENE DIFFERENTIAL MANOMETER (1 OF 12 SHOWN)

FIGURE 9
DECOMPOSITION FLASK AND HEAD ASSEMBLY

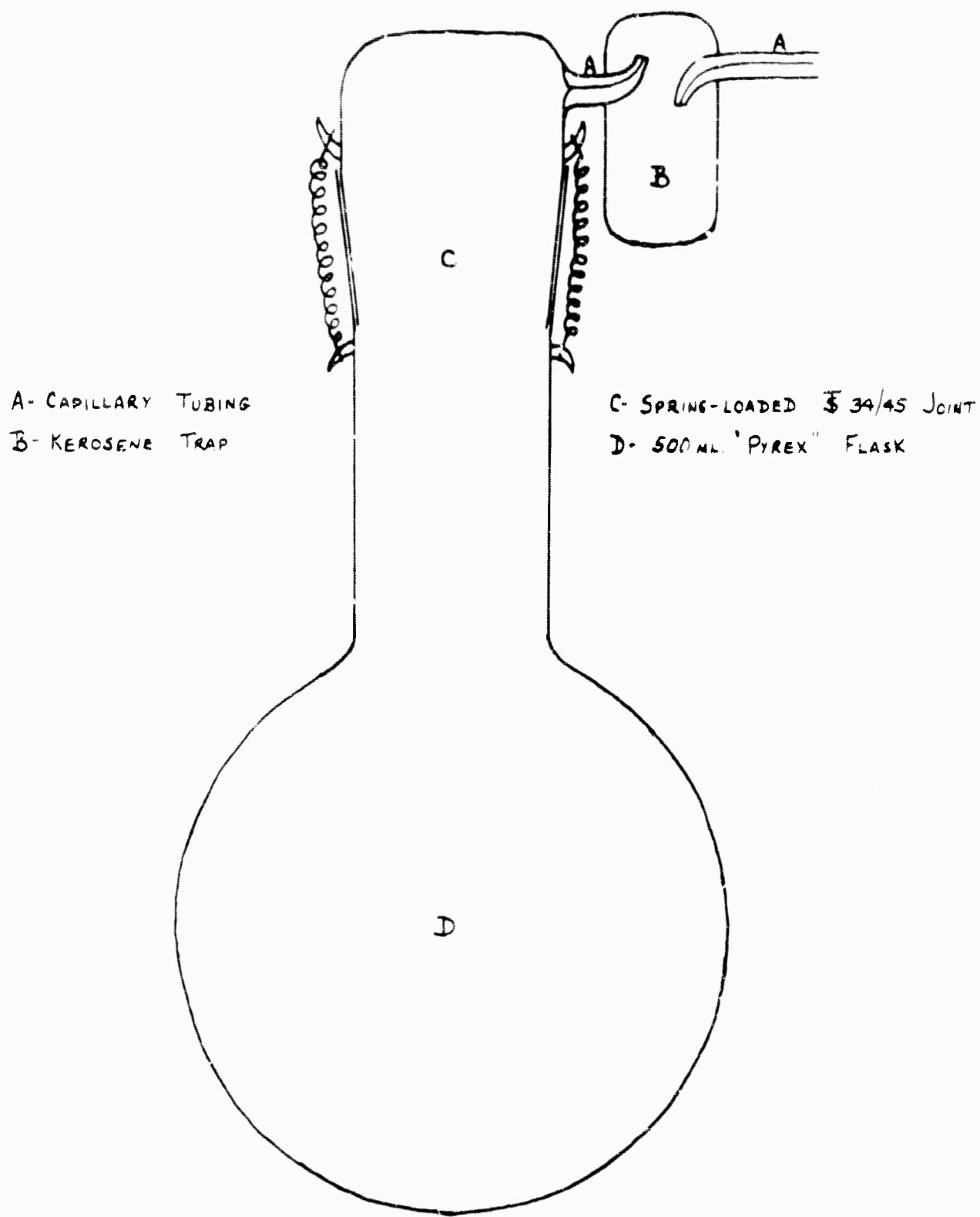

FIGURE 10

RATES OF DECOMPOSITION AT -60°C.
COMMERCIAL HIGH STRENGTH H₂O₂

NOTES

1. This Figure consists of 11 parts, which follow.
2. The 98% H₂O₂ was obtained from a single manufacturer.
3. The 90% H₂O₂ was obtained from three manufacturers, designated A, B, and C.
4. The two types of curves plotted are:
 - a. "Incremental" or "rate" curves (broken lines) show the apparent fraction (in ppm) of the H₂O₂ sample decomposed per day.
 - b. "Cumulative" curves (solid lines) show the apparent total amount (in ppm of original sample) decomposed at any given time.

SAMPLE 1
(90% H₂O₂ - A)

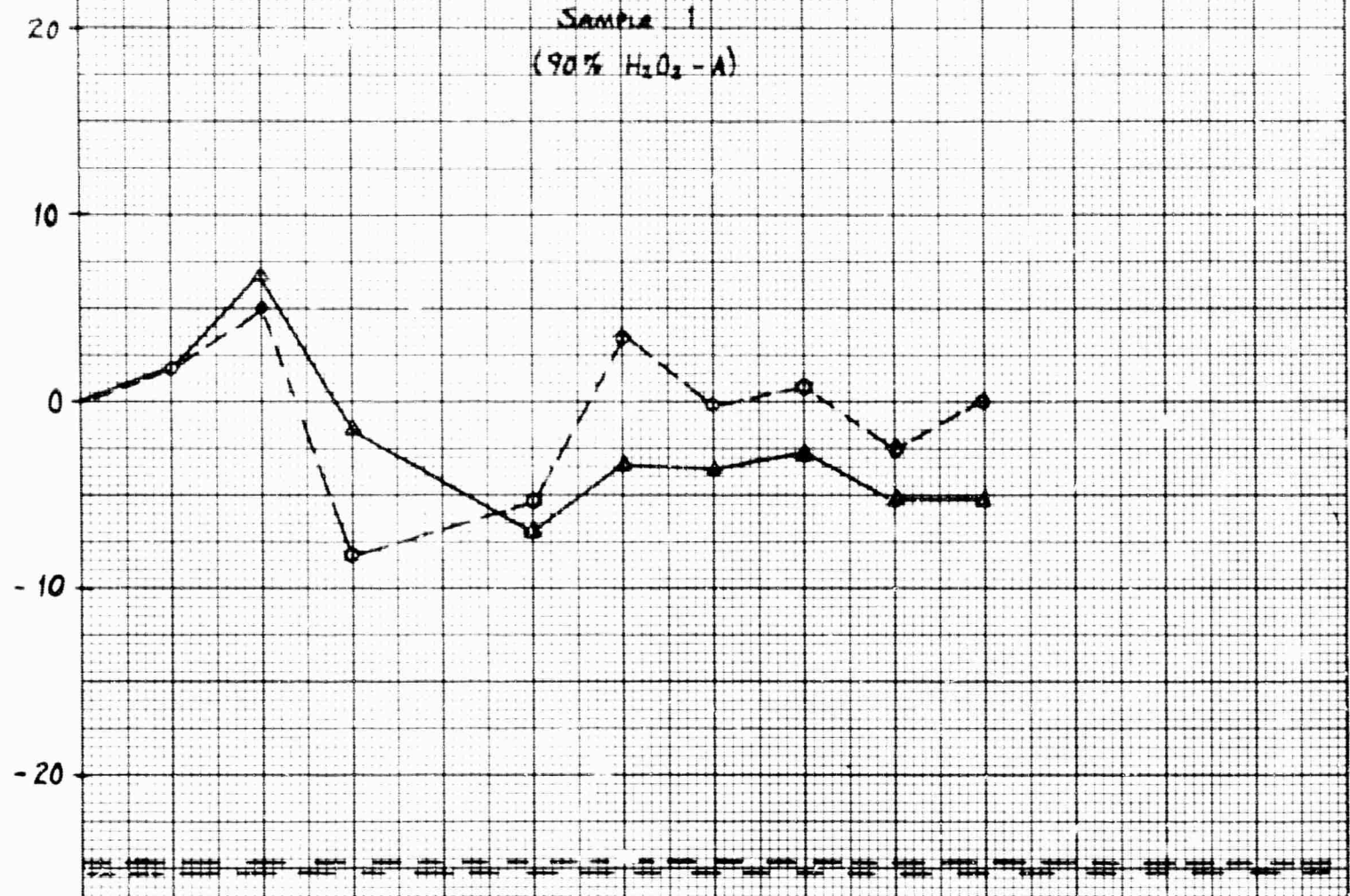

SAMPLE 2
(90% H₂O₂ - A)

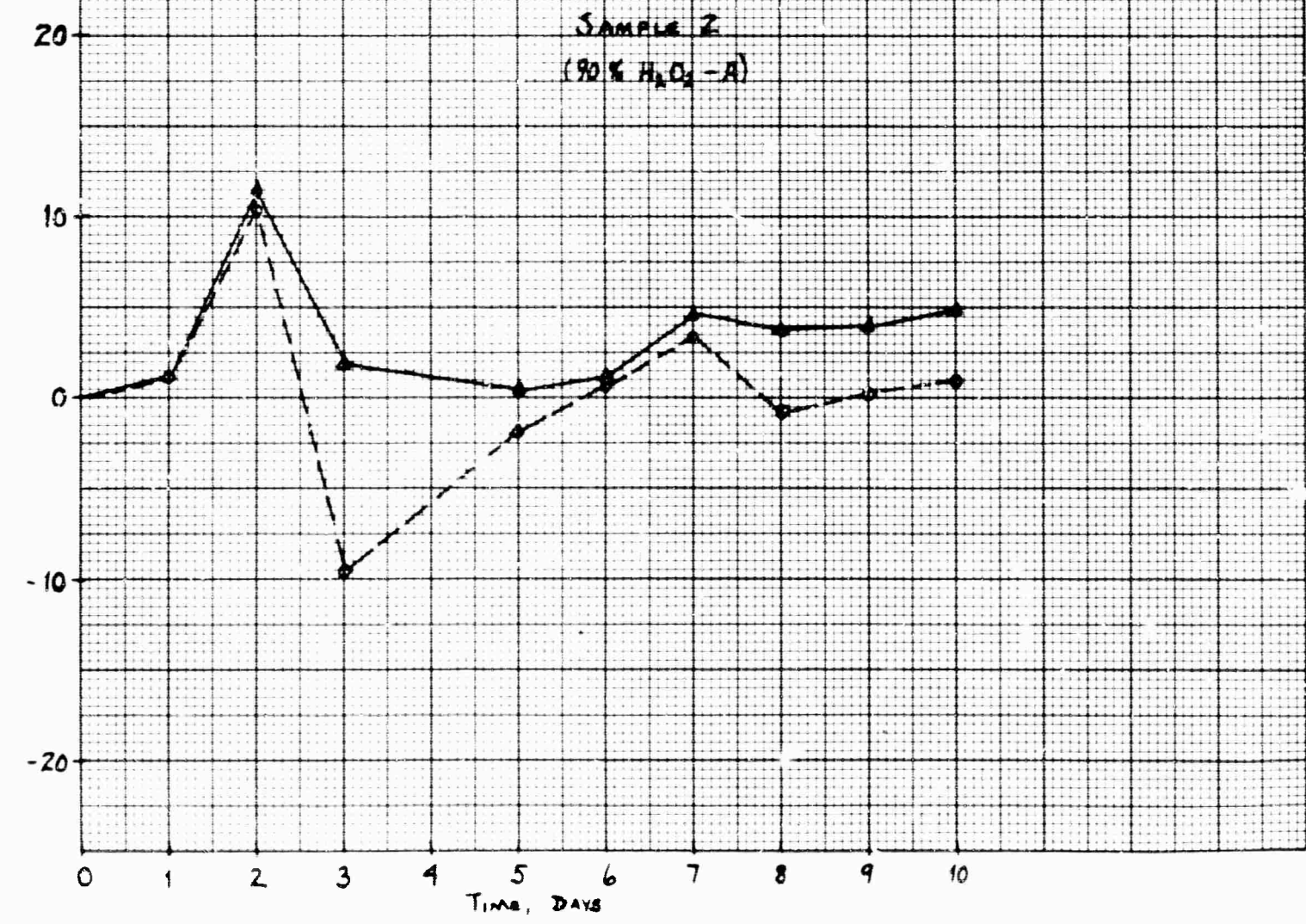

Time, DAYS

DECOMPOSED

SAMPLE 3
(90% H_2O_2 - A)

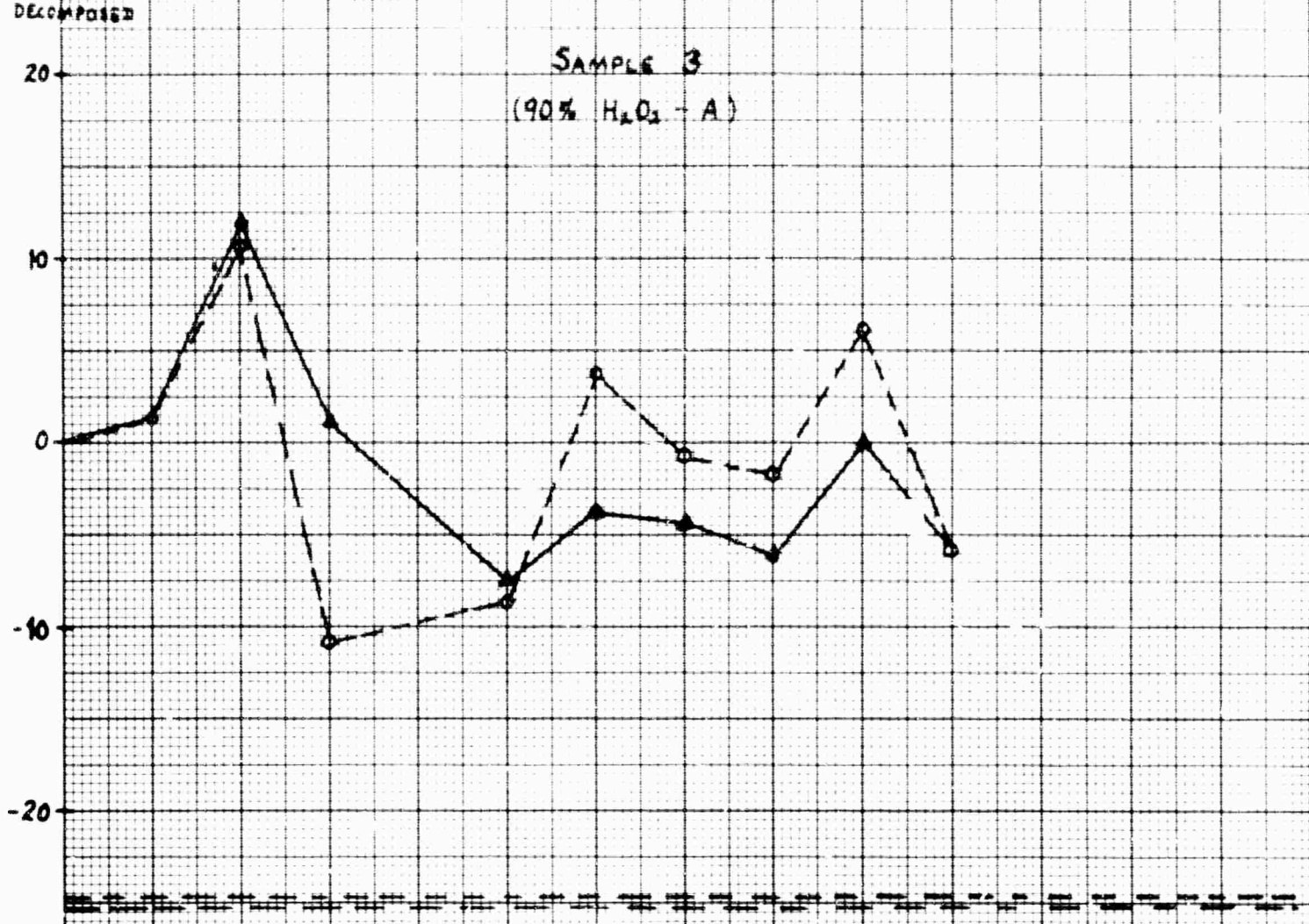

SAMPLE 4
(98% H_2O_2)

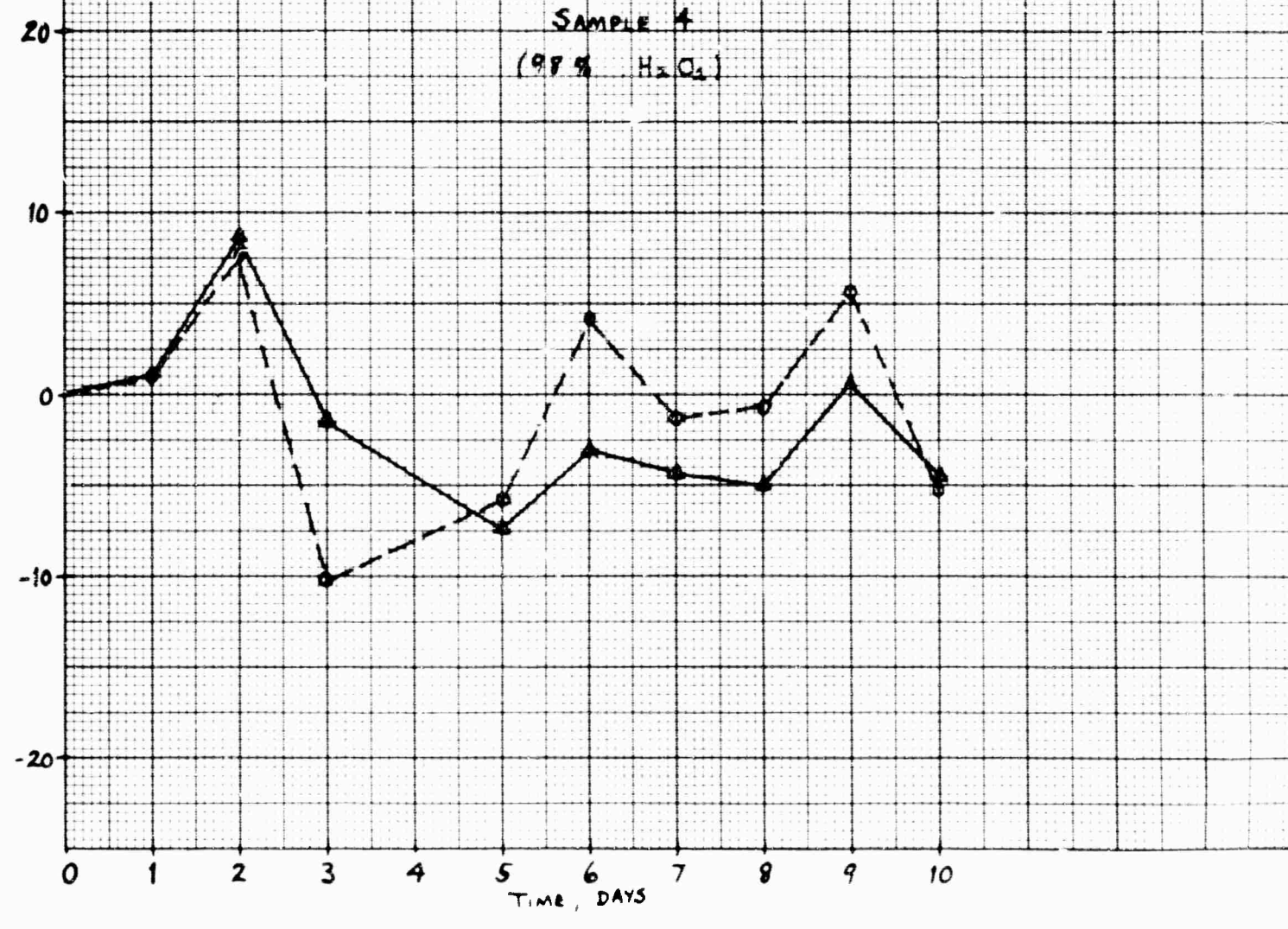

TIME, DAYS

DECOMPOSED

SAMPLE 5
(97% H₂O₂)

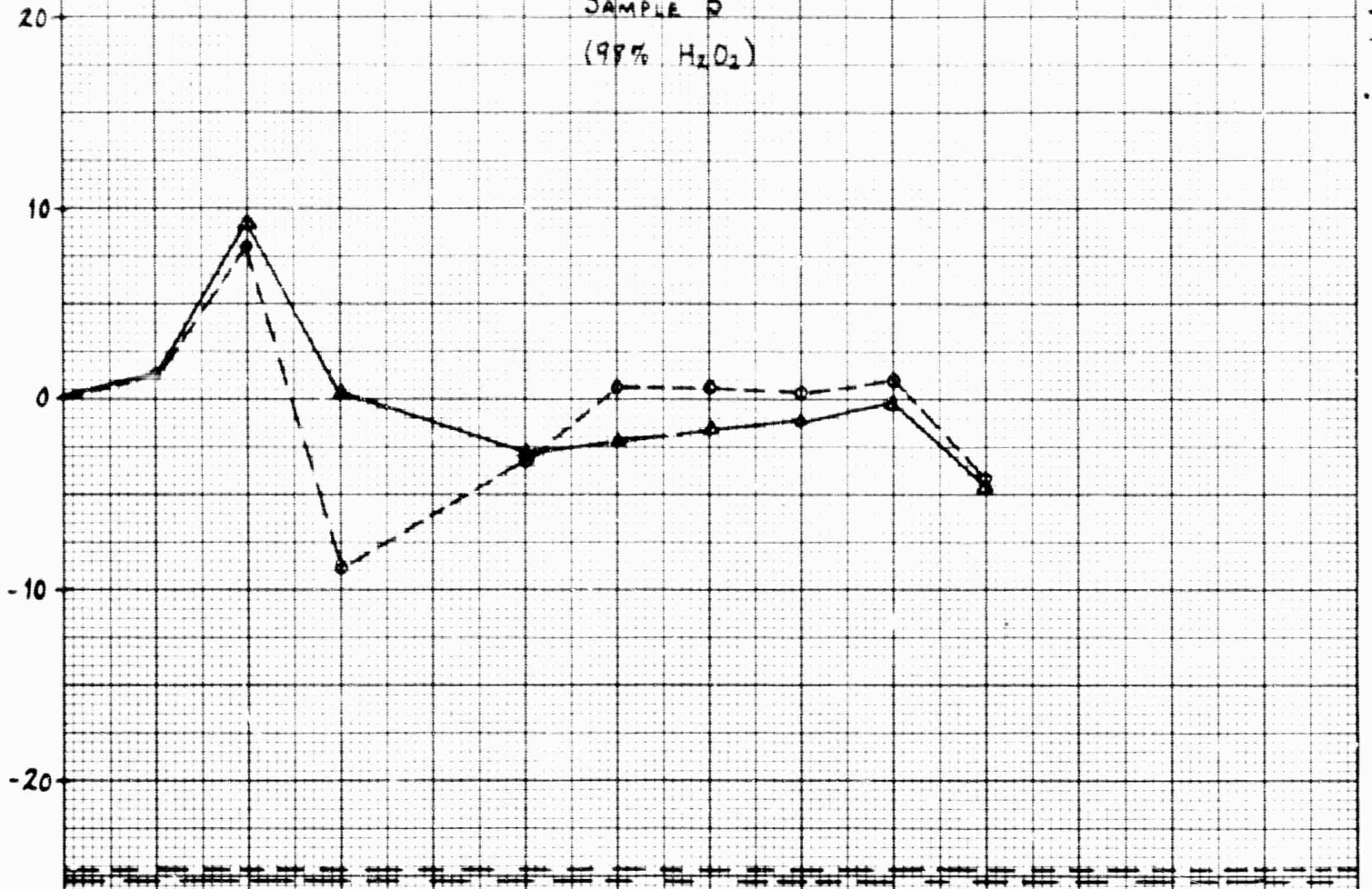

SAMPLE 6
(98% H₂O₂)

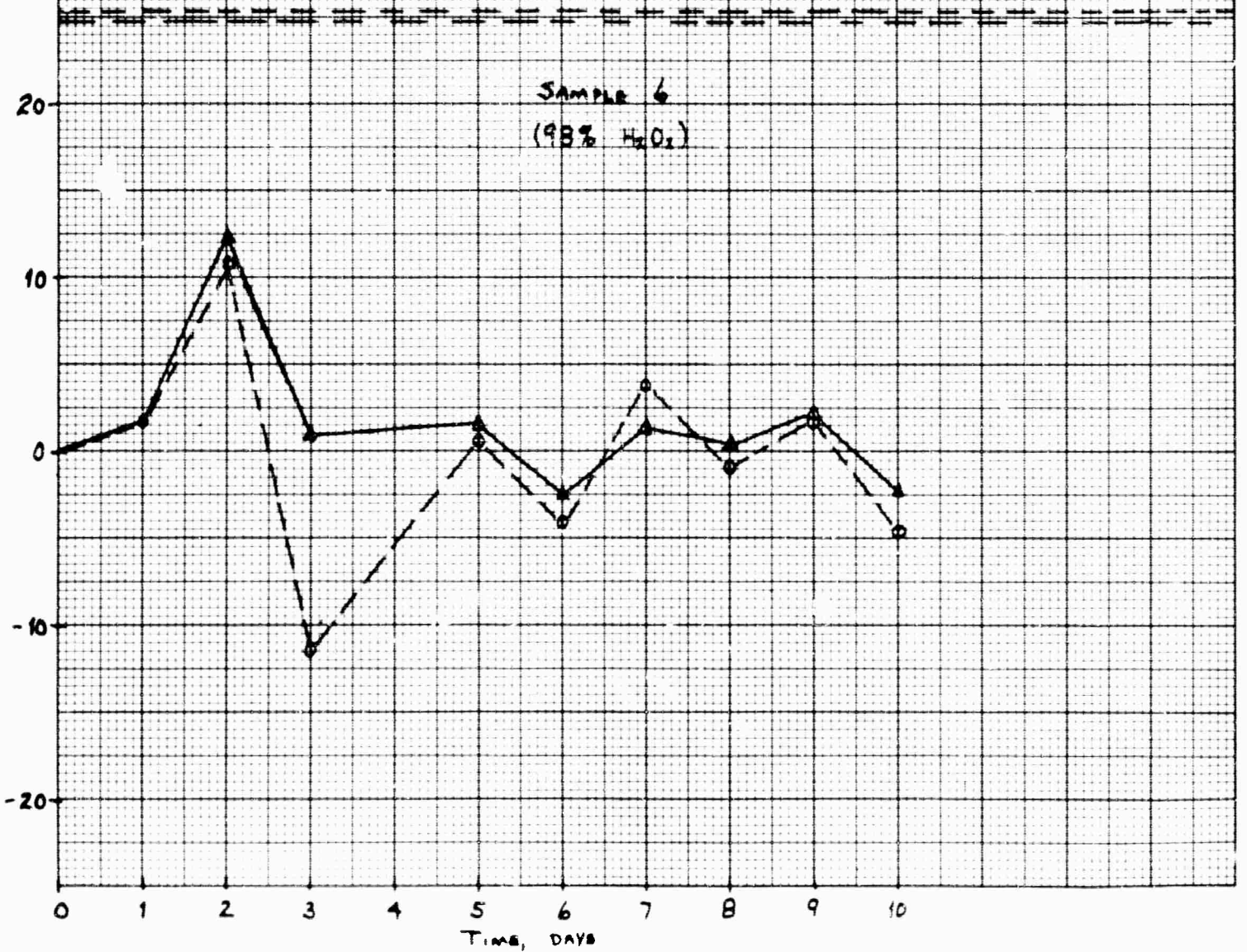

Time, DAYS

Decomposed

SAMPLE 7
(90% H₂O₂ B)

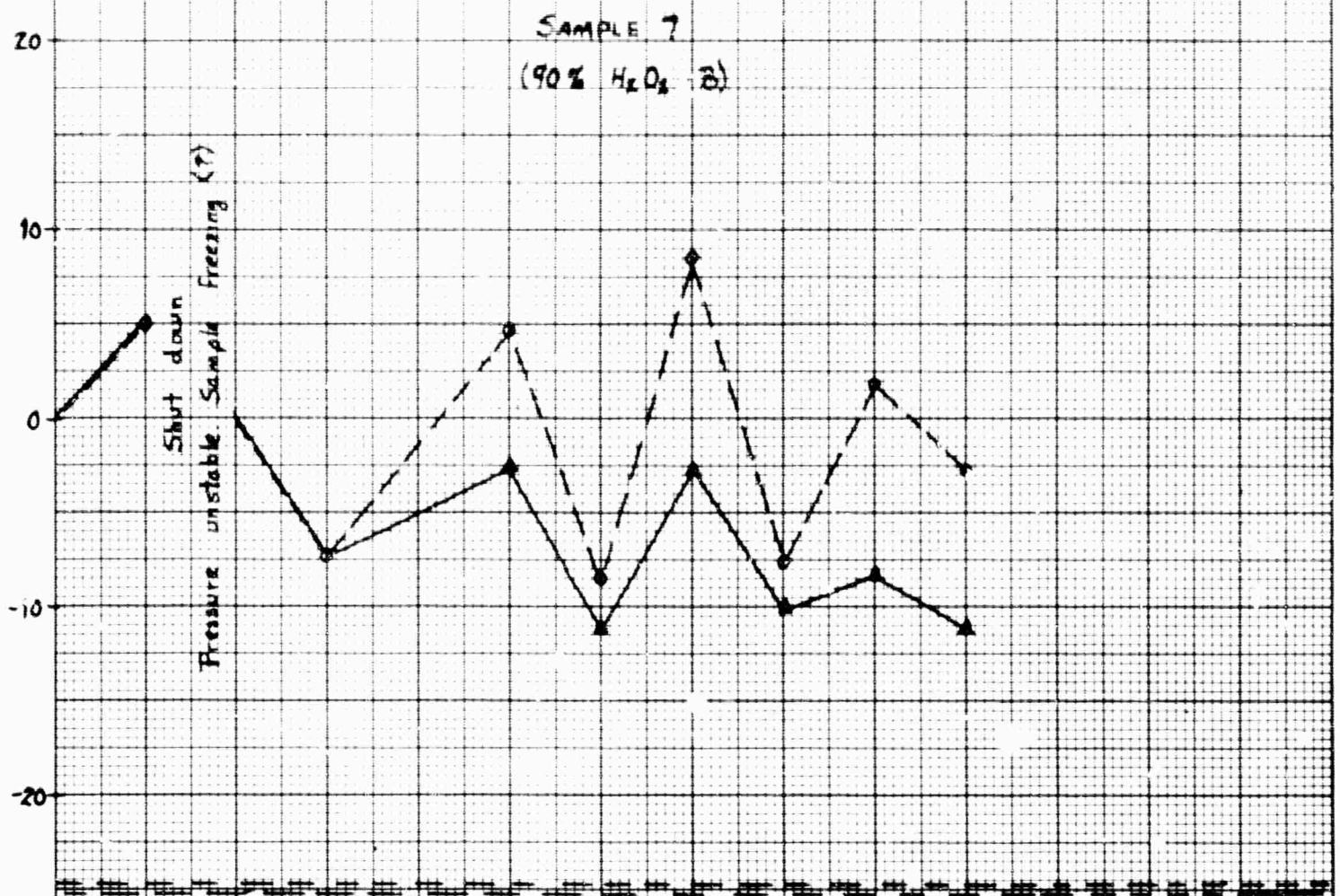

SAMPLE 8
(90% H₂O₂ B)

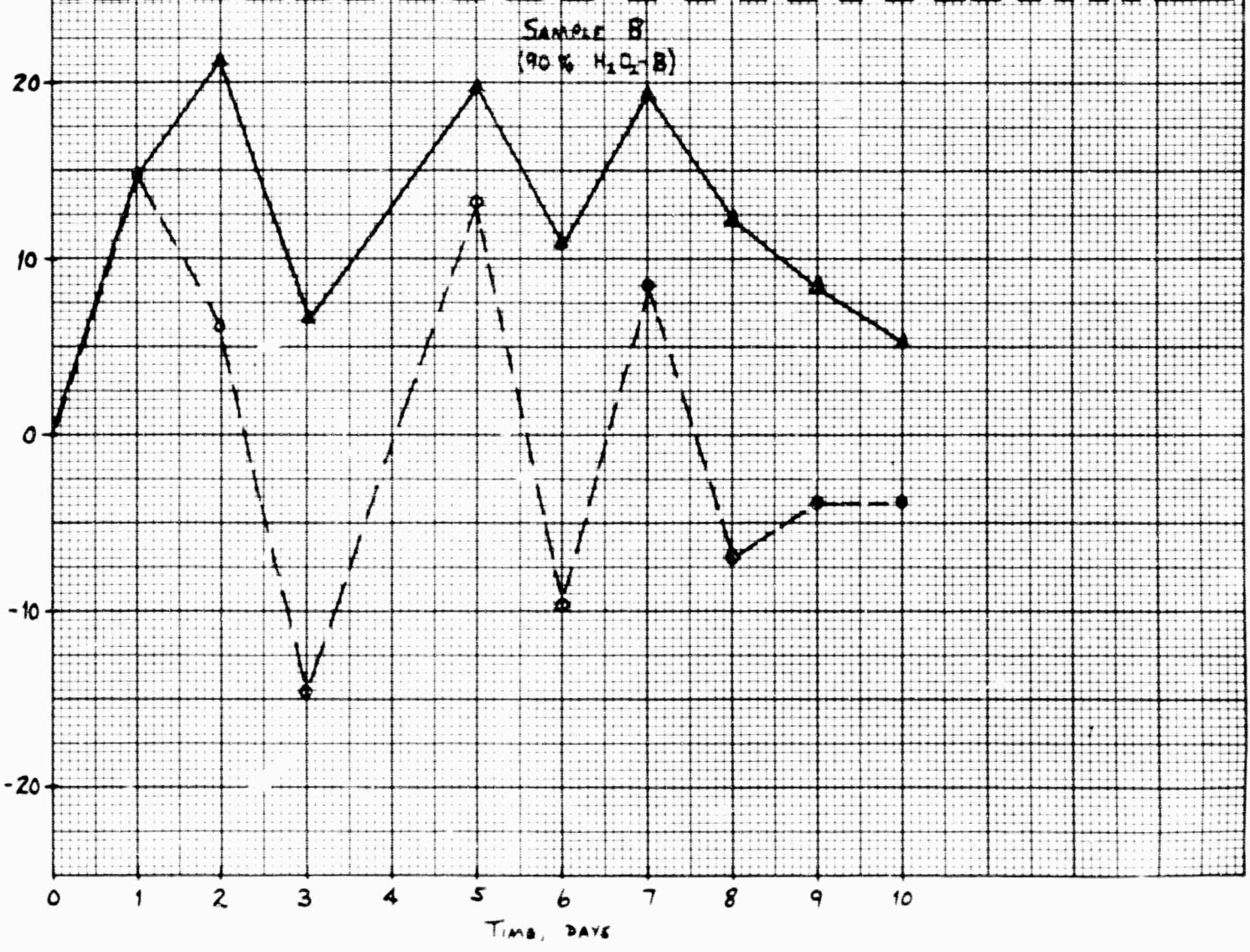

Time, DAYS

DECOMPOSED

SAMPLE 10
(90% H₂O₂ - C)

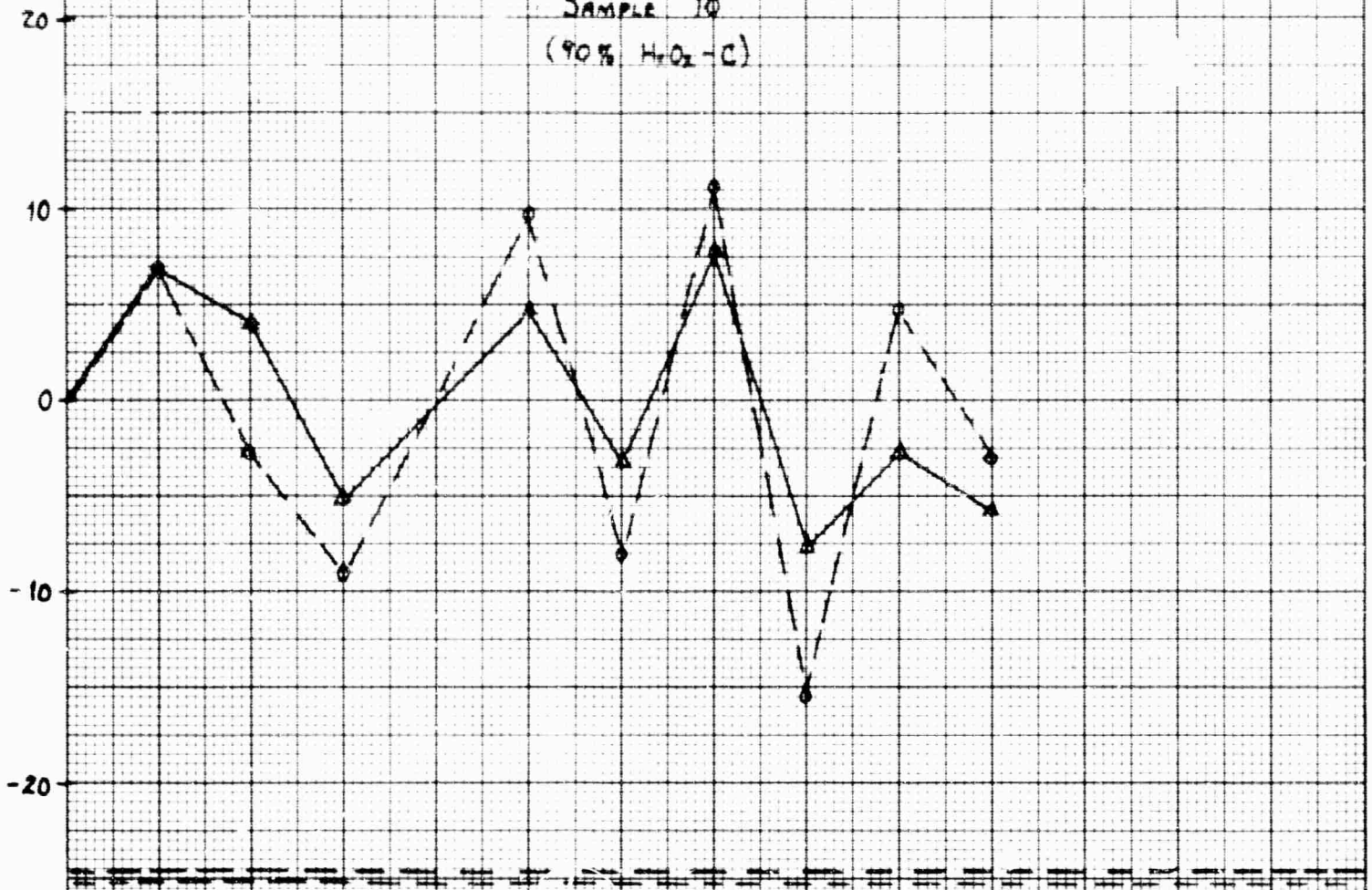

SAMPLE 11
(90% H₂O₂ - C)

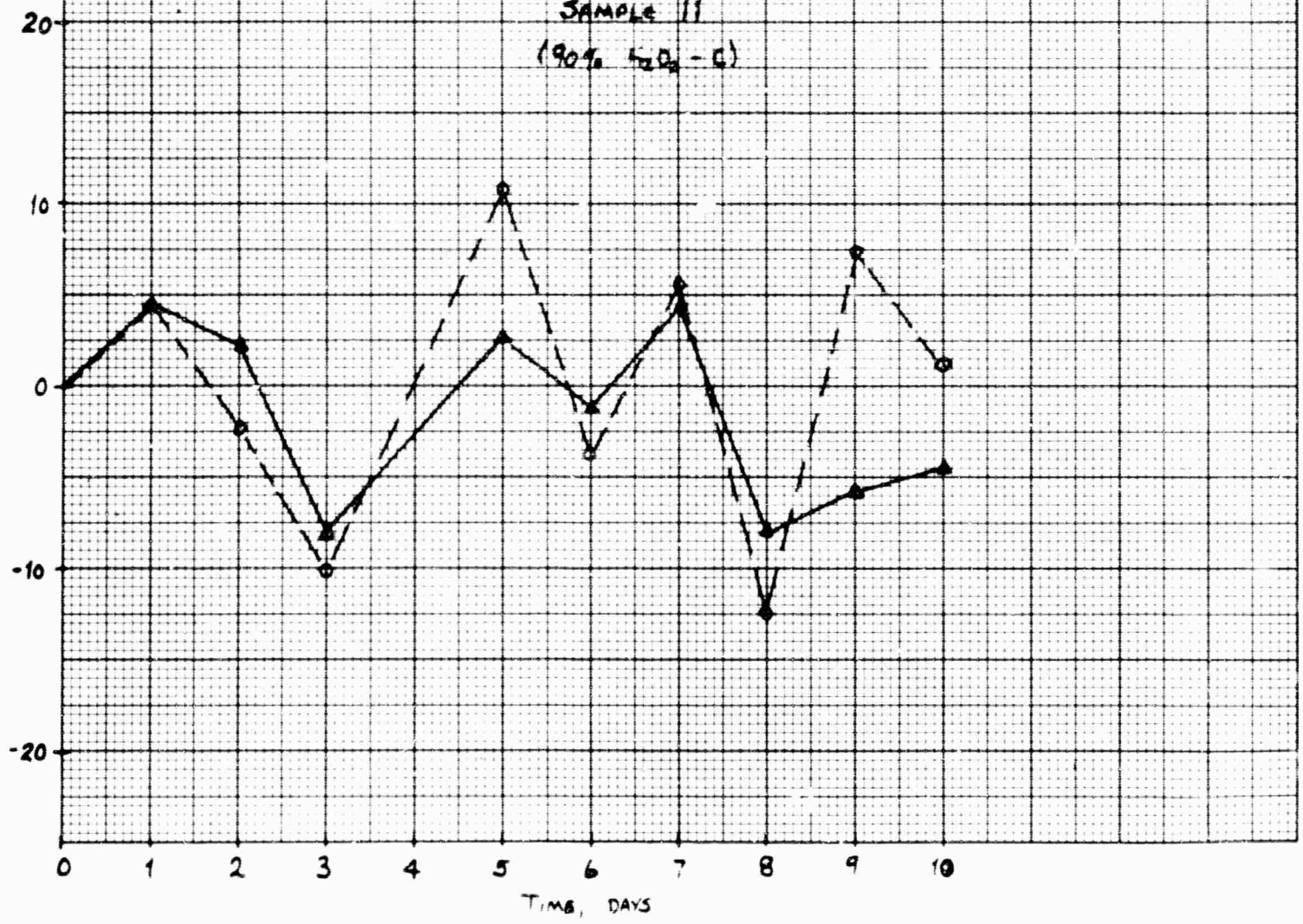

Time, DAYS

SAMPLE 1E
(90% H₂O₂ - C)

