

AD 612053

MEMORANDUM

RM-4431-PR

JANUARY 1965

COPY	<u>2</u>	OF	<u>3</u>	<u>R</u>
HARD COPY	\$. 2.00			
MICROFICHE	\$. 0.50			

27P

DIGITAL COMMUNICATIONS
AND EDP FOR AN ADVANCED
TACTICAL AIR CONTROL SYSTEM:
A PRELIMINARY STUDY

G. M. Northrop

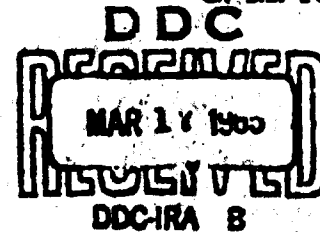

PREPARED FOR:

UNITED STATES AIR FORCE PROJECT RAND

The **RAND** Corporation
SANTA MONICA • CALIFORNIA

ARCHIVE COPY

MEMORANDUM

RM-4431-PR

JANUARY 1965

DIGITAL COMMUNICATIONS
AND EDP FOR AN ADVANCED
TACTICAL AIR CONTROL SYSTEM:
A PRELIMINARY STUDY

G. M. Northrop

This research is sponsored by the United States Air Force under Project RAND—Contract No. AF 49(638)-700 monitored by the Directorate of Development Plans, Deputy Chief of Staff, Research and Development, Hq USAF. Views or conclusions contained in this Memorandum should not be interpreted as representing the official opinion or policy of the United States Air Force.

DDC AVAILABILITY NOTICE

Qualified requesters may obtain copies of this report from the Defense Documentation Center (DDC).

Approved for OTS release

The RAND Corporation

1700 MAIN ST • SANTA MONICA • CALIFORNIA • 90406

PREFACE

This Memorandum was prepared as part of The RAND Corporation's continuing investigation of command, control, and communications pertinent to Air Force operations. The brief study described herein focuses on some of the communication and data processing characteristics of an Advanced Tactical Air Control System.

The author's interest in this area was stimulated by RAND colleague G. F. Good's investigation of an electronic device to permit a forward air controller and an attacking aircraft pilot to communicate via digitally coded messages, thus transcending any potential language barrier. Attendance at the Air Ground Operations School, Eglin Air Force Base, gave the author added insight into present modes of tactical operations. Further stimulus came from assisting the Electronic Systems Division in the course of its study of an Advanced Tactical Air Control System (Post-1972).

This preliminary study examines some characteristics of the present Tactical Air Control System, points out some difficulties that could arise with the introduction of automatic digital data processing, and suggests means of avoiding these difficulties. A three-phase program of equipment acquisition is outlined. With modest cost, Phase I of this program could begin immediately, if desired. Present system capability would thus be enhanced while acquiring data and experience leading in an evolutionary manner to specific operational requirements for more complex and expensive system elements.

SUMMARY

The present Tactical Air Control System does not take advantage of the myriad advances during the past decade in the fields of digital communications and electronic data processing. This Memorandum may act as a vehicle of discussion for a possible three-phase program for acquiring digital communication and data processing equipment for an Advanced Tactical Air Control System (Post-1972). The program is predicated on the basis of an evolutionary growth schedule that calls for the acquisition of the least expensive (but conceptually most important) items first: The Coding/Decoding/Acknowledging (CDA) devices to be used at the points of message origin and destination. It is suggested that these devices could be made available within two years or less and that they could improve markedly the present TACS capability, as well as provide a firm base for developing requirements for more sophisticated elements.

Later phases of the proposed program would include the introduction of field-service hard-copy printers, format message composers, digital computers of varying capacities and capabilities, displays having various levels of automation, and so forth.

Future changes in weapon systems and ground warfare tactics will doubtless call for modifications of the present TACS structure. But the fundamental need for rapid and accurate transmission and reception of messages and performance of data processing also will doubtless remain and probably will continue to grow in importance. Digital techniques are being widely applied in the fields of communications and data processing. It now remains to apply these techniques to the tactical air control task in a suitable evolutionary fashion to gain continuing improvements at reasonable cost.

ACKNOWLEDGMENTS

The author acknowledges with gratitude the helpful comments of many RAND colleagues, particularly P. Baran, G. F. Good, J. P. Haverly, C. R. Lindholm and A. E. Wessel. Of course, the author remains solely responsible for the views expressed in this Memorandum.

Preceding Page Blank

CONTENTS

PREFACE	iii
SUMMARY	v
ACKNOWLEDGMENTS	vii
Section	
I. INTRODUCTION	1
II. ELEMENTS OF THE PRESENT SYSTEM	4
Command and Control	4
Messages	6
Current Communications	6
III. ELECTRONIC DATA PROCESSING FOR POST-1972	10
IV. A CODED-MESSAGE CONCEPT FOR A TACTICAL AIR CONTROL SYSTEM (PPOST-1972)	12
Phase I	13
Phase II	14
Phase III	14
V. OTHER FACETS OF THE PROBLEM	19
Applicability	19
Inter-service Compatibility	19
Security	20
VI. CONCLUSIONS	21

Preceding Page Blank

I. INTRODUCTION

One of the more marked differences between the present Tactical Air Control System and the Advanced Tactical Air Control System (Post-1972) presently under consideration in various Air Force agencies and elsewhere is likely to be the introduction of digital communications and electronic data processing. The present system reflects essentially none of the myriad advances over the past decade in these fields, although a large body of knowledge, experience, and hardware has accrued from studies and developments by all the armed services.

In today's Tactical Air Control System, the more urgent messages are usually transmitted in voice form and must be hand-copied for further action. Less urgent messages may be transmitted by teletype, but here, too, time delays are often encountered before the information can be processed. It is generally acknowledged that electronic data processing could reduce these time delays, and in addition could provide such benefits as greater accuracy for certain staff actions requiring computations and/or sorting, searching, comparing, and correlating certain data prior to making basic decisions. Of course, a question arises concerning the degree that digital data transmission and processing would be useful in the command, control, and communication structure. For example, should digital data processing exist only at the higher echelons of command, or should most messages flow in coded digital form from the point of message origin (which may be the lowest level of command and control) throughout all parts of the system?

This Memorandum presents a brief treatment of this and other questions that are apt to arise in the event that digital communications and data processing are introduced in the Advanced Tactical Air Control System. The concepts suggested are intended to serve primarily as a vehicle for discussion and are not the result of an extensive study of great depth and detail. Indeed, in this short work it has been possible only to outline what are considered to be some of the more important facets of the problem.

It appears that introducing digital data processing at only the higher echelons of command in the field is apt to prove impractical, due to intolerable saturation levels imposed by the time-consuming task of converting voice or teletype messages into a form suitable for digital data processing. This Memorandum suggests a program that may help to circumvent this difficulty by requiring that all "standard" messages be transmitted in a suitable digital form from the point of message origin. This mode of operation would necessitate a Coding/Decoding/Acknowledging (CDA) device at the sending and receiving ends of the communication link. With information in appropriate digital form throughout the lower echelons, it would be feasible to perform extensive data processing at the various higher command echelons.

To hold costs to a minimum, the CDA device might operate as a plug-in unit with present voice transceiving equipment. In any event, voice-channel information bandwidth would be desirable to assure a backup voice capability in the event of CDA failure, or the need for voice communications between the points of message origin and receipt. Early versions of such CDA devices are available today.

The following discussion outlines some characteristics of the present Tactical Air Control System, highlights some difficulties that might occur with the introduction of digital data processing into the system, and suggests means of avoiding these difficulties. A three-phase program of equipment acquisition is outlined. With modest cost, Phase I of this program probably could begin immediately, if desired. Present system capability would thus be enhanced while acquiring data and experience leading to specific operational requirements for more complex and expensive system elements.

The concept described in this Memorandum has potential for very broad application. Possible areas of utility include air traffic control, ground control of attack aircraft (forward air controller to aircraft), request nets for all aspects of preplanned and immediate air support, and so forth. In this Memorandum the coded message concept for an Advanced Tactical Air Control System has been illustrated by discussing its application in the context of immediate requests

for close air support. However, this concentration is not intended to imply any limitation of the application of the concept. The close air support mission was selected as a vehicle of discussion only because of the considerable interest presently being devoted to it by the services and various agencies of the DOD.

II. ELEMENTS OF THE PRESENT SYSTEM

COMMAND AND CONTROL

To outline more fully the problem of an Advanced Tactical Air Control System, we will first look at the present system. Figure 1 is an outline map showing a typical Army corps area of responsibility in a joint task force operation. The corps front, or Forward Edge of the Battle Area (FEBA), might be 20 to 60 miles in width. The corps consists of at least two divisions; in Fig. 1, two divisions are on the FEBA and a third is in reserve in the rear. Each division contains three brigades and each brigade, three battalions. The Air Force probably would provide air defense and air control elements such as the Control and Reporting Center (CRC), Control and Reporting Post (CRP), etc., as shown in the lower left of Fig. 1. Other Air Force elements would likely be the Tactical Air Control Center (TACC) associated with the Air Force Forces Command Post (AFFCP) and a Direct Air Support Center (DASC) operating in conjunction with the Army's Tactical Air Support Element (TASE). Other Army command elements include the Corps Tactical Operation Center (CTOC) and the Army Forces Command Post (ARFCP). (The ARFCP, CTOC, DASC, and TASE essentially form the Corps Headquarters.)

The Air Force would also supply Tactical Air Control Parties (TACPs) at battalion, brigade, and division level. In Fig. 1, the TACPs that consist of an Air Liaison Officer (ALO) and a Forward Air Controller (FAC) plus requisite communication personnel are designated by the subscript "1." The subscript "2" indicates a TACP of only an ALO and necessary communication personnel. A TACP₁ is attached to each battalion, while a TACP₂ is attached to each brigade and division headquarters.

Figure 1 also shows a joint task force (JTF) command element and the associated joint operation center (JOC), (lower left corner) as well as tactical fighter elements, and tactical reconnaissance elements (lower right corner). Tactical airlift elements are not shown, but their use when required is implied.

FEBA

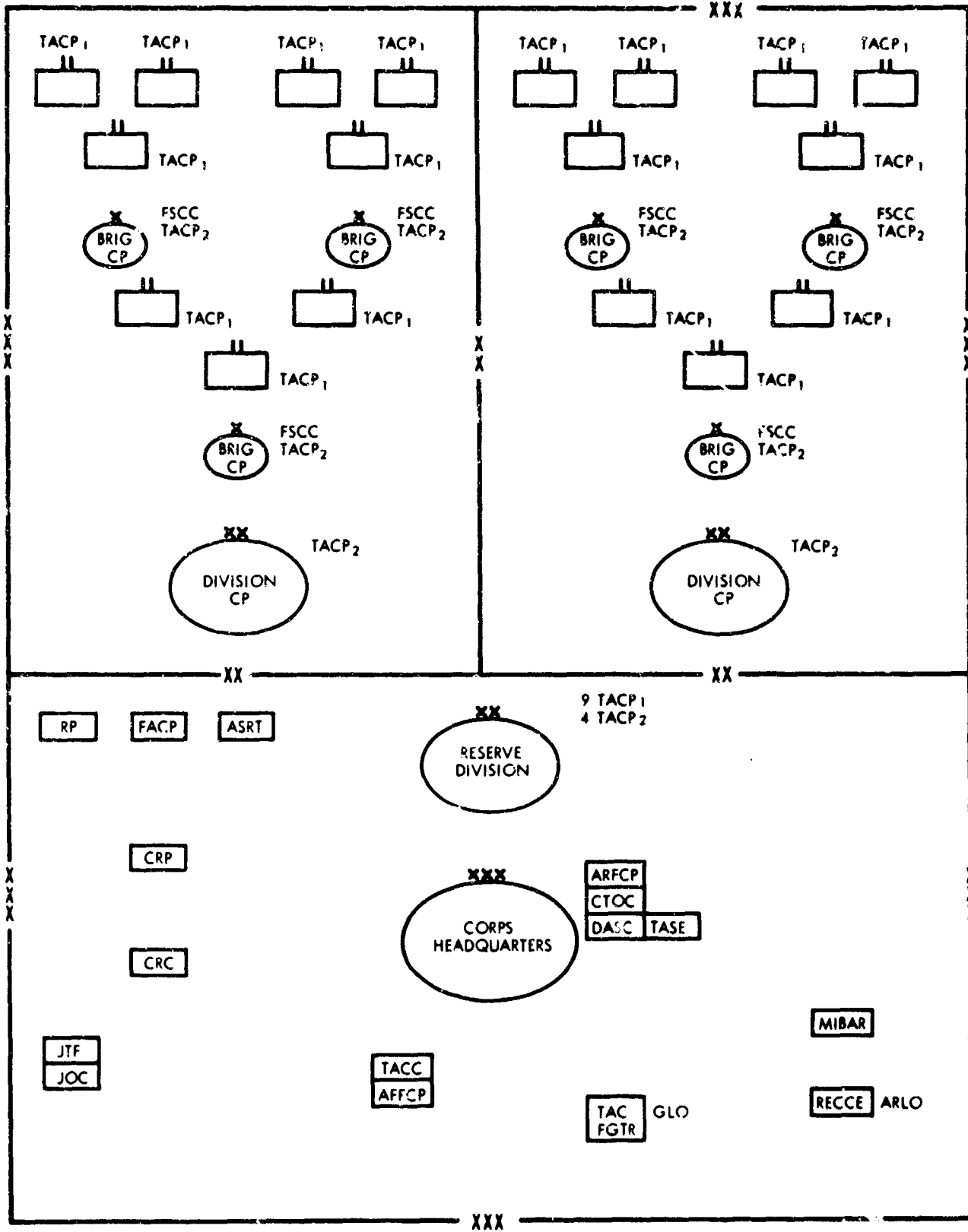

- | | | | |
|-------|---|-------|---|
| JTF | Joint Task Force | FACP | Forward Air Control Post |
| JOC | Joint Operations Center | ASRT | Air Support Radar Team |
| AFFCP | Air Force Forces Command Post | RP | Reporting Post |
| ARFCP | Army Forces Command Post | CRP | Control & Reporting Post |
| TACC | Tactical Air Control Center | CRC | Control & Reporting Center |
| CTOC | Corps Tactical Operations Center | GLO | Ground Liaison Officer |
| DASC | Direct Air Support Center | ARLO | Airborne Reconnaissance Liaison Officer |
| TASE | Tactical Air Support Element | TACP1 | ALO + FAC + Communication Personnel |
| MIBAR | Military Intelligence Battalion (Airborne Reconnaissance) | TACP2 | ALO + Communication Personnel |
| FSCC | Fire Support Control Center | | |

Fig. 1—Present Tactical Air Control System

MESSAGES

Today's tactical air elements generally respond to both "immediate requests" and "preplanned requests" for air support. Immediate requests may be for close air support (CAS), airlift, reconnaissance, and possibly air defense. Preplanned requests are likely to be for close air support, airlift, reconnaissance, air defense, and interdiction. At present, requests for air support are transmitted by teletype or voice. Standard message formats are used to keep the task of hand-copying at a minimum.

We assume for this discussion that in the post-1972 era the TAC air elements will be required to respond to immediate and preplanned requests much as they do today.

CURRENT COMMUNICATIONS

Figure 2 outlines some of the communication links of today's Tactical Air Control System. Figure 3 shows some of the communication links for the present Army system. The command and control elements shown in Figs. 2 and 3 correspond to those in Fig. 1. (The communication links were omitted from Fig. 1 for clarity of presentation.)

In today's system, preplanned requests for missions are apt to come from the air liaison officers (ALOs) at battalion, brigade, and division command posts. These requests reflect cooperative and coordinated planning between Army commanders and their Air Force advisors (ALOs) at these various levels of field command. Usually a period of about 8 to 24 hours, or more, may elapse between the time of a preplanned request and execution of the mission. Immediate requests for air support can be made by the forward air controllers (FACs) and ALOs at battalion level and the ALOs at brigade and division headquarters.

For a "conventional" division there will be about nine FACs and thirteen ALOs. Thus, it is possible that requests for immediate air support could come from about twenty-two different message sources in a "conventional" division. Carried one step further, this

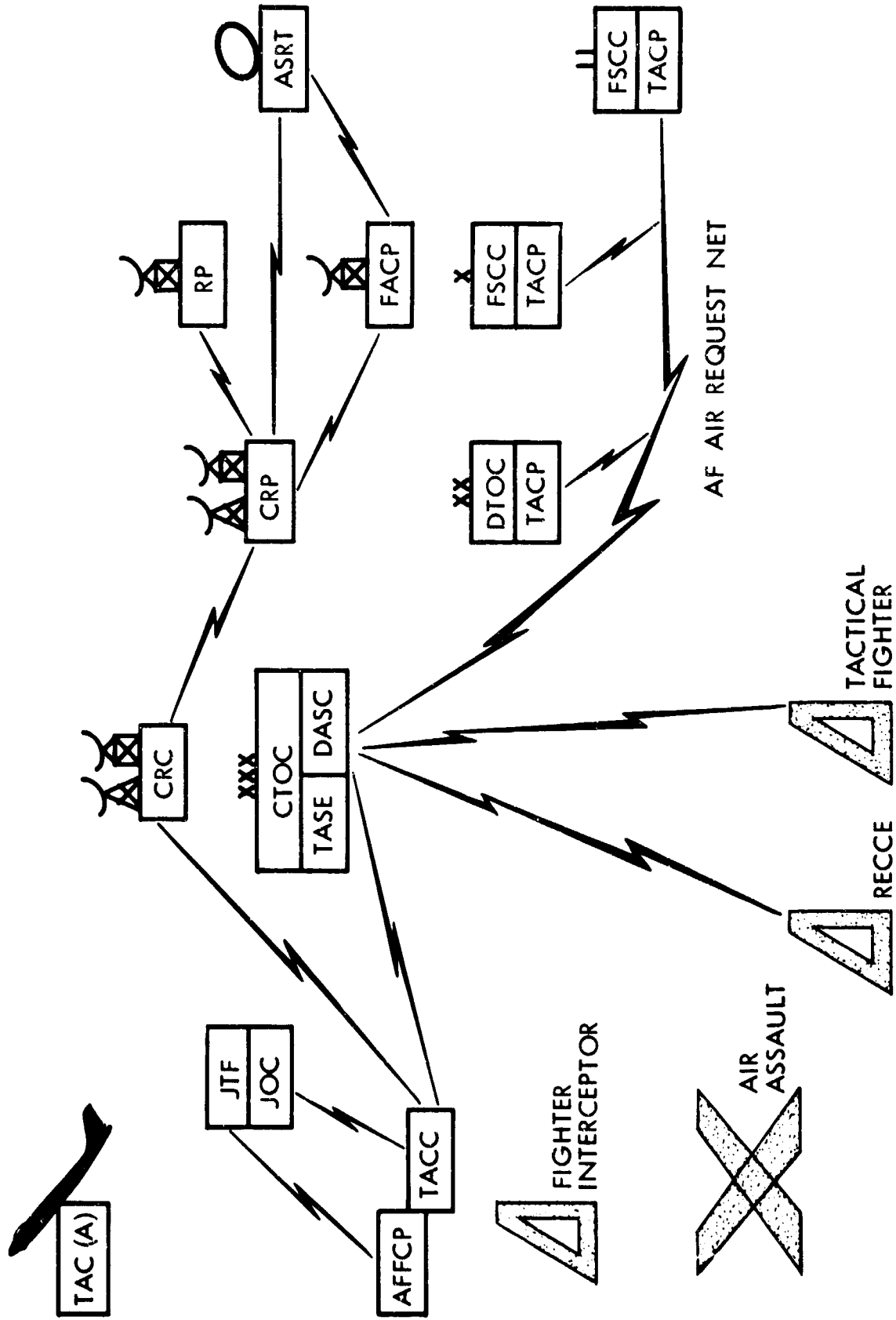

Fig. 2 - Tactical air control system (TACS)

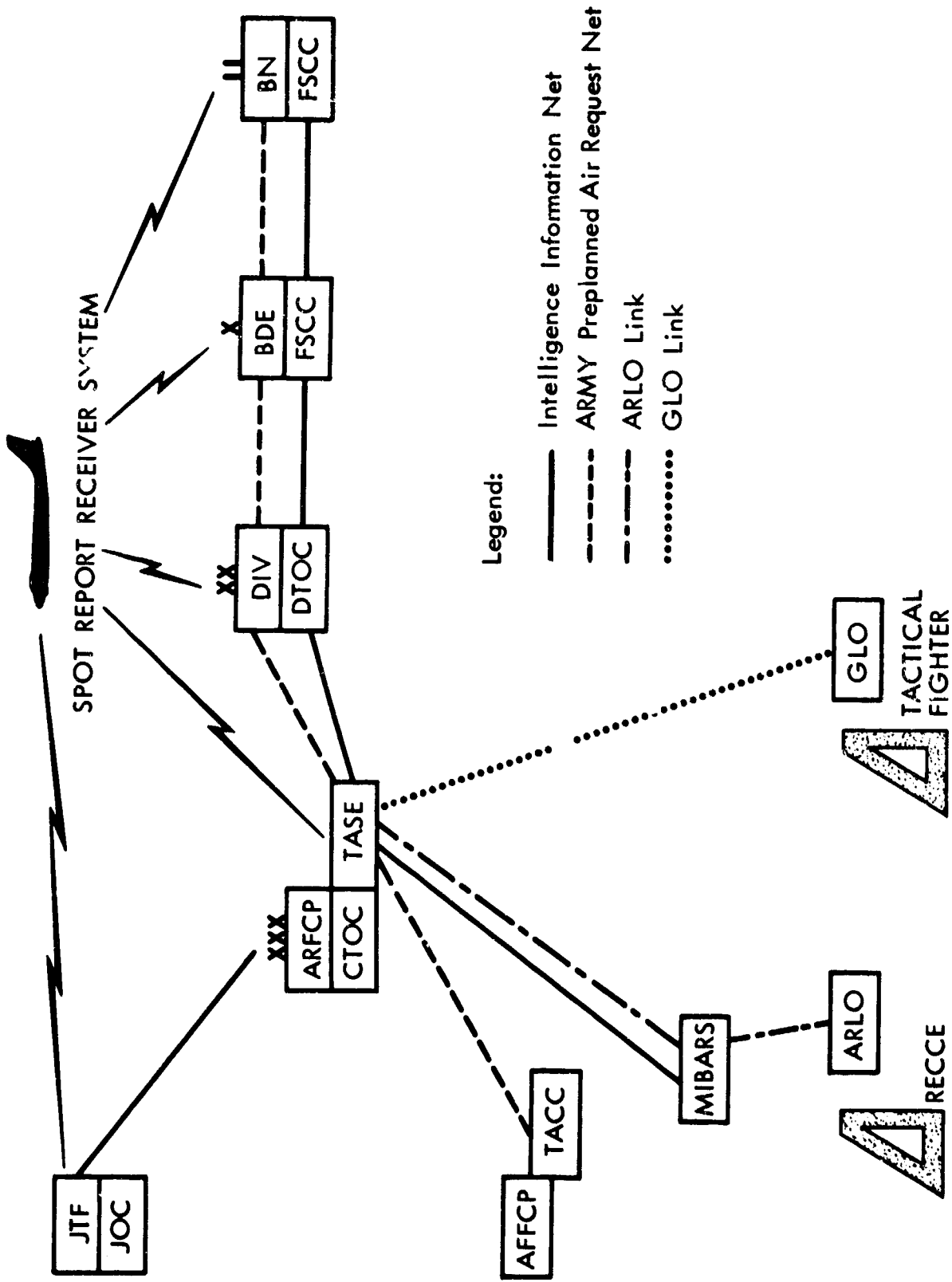

Fig. 3—Army air ground system (AAGS)

implies that for a corps consisting of three divisions on the line, as many as sixty-six different sources could conceivably be generating requests for close air support, reconnaissance, air defense and airlift.

In the present system these requests for immediate support--especially close air support--would be transmitted by voice between (typically) an FAC and the Direct Air Support Center (DASC) via HF SSB. The message would be monitored at the brigade and division CPs. Message acknowledgment (by voice) at the DASC is required from brigade and division CPs indicating that they are aware that a request has been transmitted from an FAC to the DASC.* If brigade considers the request to be valid, it so indicates by silence after message acknowledgment; similarly, if division considers that the request for support cannot be met through use of division fire support, it also indicates the message to be a valid request by silence after acknowledgment; otherwise division informs the DASC that the request for air support is not valid.

At the DASC, the message from the FAC is copied by hand (an original and one carbon copy) on a standard format. The carbon copy is physically handed to someone in the TASE if the TASE and DASC are adjacent, or it is physically carried to the TASE if they are separated.

In the DASC, decisions are made as to how to meet the request for immediate support, while in the TASE, similar decisions are made as to whether or not the request can be met by use of corps fire support (including missiles). If it is decided in the TASE that the request cannot be met by corps support, the DASC is so informed via the intercom system that operates between DASC and TASE. The DASC notifies the TACC, the CRC, and the appropriate TAC fighter or TAC reconnaissance organization concerning the request for immediate support. The request may be satisfied by aircraft in the air on patrol, by aircraft in the air on another mission, or by aircraft on strip alert.

*During the recent "Indian River" exercises, the step of acknowledgment by brigade and division CPs was sometimes omitted.

III. ELECTRONIC DATA PROCESSING FOR POST-1972

Since we are considering a potential system for a time period possibly seven years from now, it is reasonable to assume that some of the data processing task described or implied in Sec. II will be performed in that time period by means of electronic data processing (EDP), i.e., digital computers probably will be in use at various field levels of command.

We indicated earlier that certain decisions must be made at brigade, division, and corps command levels. For example, it must be determined whether or not a request for immediate air support is to be met by use of Army resources such as brigade, division, or corps artillery, or is, indeed, to be fulfilled by use of Air Force resources. Previously, it was shown that for a military organization as shown in Fig. 1, as many as 27 FACs and 27 ALOs might be making requests for immediate support from only battalion level and below in each division. Thus, at each brigade CP, requests may be coming from as many as six individual sources, at the division CP from as many as 18 to 21 separate sources, and at the corps CP from up to 66 individual sources (for a three-division corps).

The prime problem arising in the use of EDP to assist staff decision-making at various command levels is that of converting voice messages into suitable digital form for data processing.

In order to avoid saturation during this process, the system should be capable of handling the maximum expected number of messages coming from the separate sources. As a rough guide, let it be assumed that a maximum of five requests for air support may come from an FAC or ALO during a period of thirty minutes.* As indicated earlier, this implies that at a brigade CP about 30 reports per half hour might be the maximum; at the division CP a maximum of about 105 requests might have to be processed per half hour; and at corps CP (DASC/TASE) a maximum of 330 requests might have to be processed in one-half hour. Obviously, this average rate of 11 messages per minute during peak periods is probably in excess of the message rate

* These message rates might typically occur when an Army unit is on the attack and meeting stubborn resistance, or when the unit is under heavy attack, or during a retrograde action.

that might be experienced in practice, but it does represent a useful upper bound.* Table 1 summarizes the data developed.

Table 1

IMMEDIATE REQUEST MESSAGE RATES (POSTULATED)

Unit	Subordinate Message Sources		Immediate Request Messages Received per 30 minutes ^a	Immediate Request Messages Received per minute ^a
	ALOs	FACs		
Brigade	3	3	30	1
Division	12	9	105	3.5
Corps (three divisions)	39	27	330	11

^aBased on an assumed generation rate of 5 messages per half hour from each ALO and FAC.

It is apparent that converting up to 330 messages in one-half hour from a handwritten or voice form into suitable digital form would require many additional people at each level of command in order to avoid saturation problems. These personnel would be in addition to the number required for handling the information after it has been processed. Thus, it becomes obvious that the application of EDP only at the higher command levels would tend to make the communication process founder at the outset because of the difficulties of converting voice or written messages into suitable digital form at these higher command levels.

*As a bench mark, it is noted that during the Korean war the Air Force, Navy and Marine Corps together often carried out as many as 1000 air support missions with fighters and fighter-bombers per day.

IV. A CODED-MESSAGE CONCEPT FOR A TACTICAL AIR CONTROL SYSTEM (POST-1972)

To alleviate the problem of converting messages into digital form for suitable data processing as described in Sec. III, it is suggested that the points of message origin (ALOs and FACs) be equipped with small devices enabling the message sender to code the message by means of setting numbered dials or by use of a coding device such as a telephone dial.* The coded message in a form suitable for electronic data processing would then be sent in some appropriate form of digital transmission.

At this point it is desirable to avoid a possible pitfall by emphasizing that the coding device would be compatible with current and projected voice communication systems. This would ensure that, in the event of failure of the coding device, a voice communications capability would still be available as a backup mode of communication.

It may appear superficially that this would be wasteful of bandwidth because message information content would be a few hundred bits at most. However, not only does the use of voice bandwidth permit a voice backup mode of communication, but it also makes possible powerful techniques for error detecting and error correcting codes needed to provide high confidence in the accuracy of the received message. The additional margin of bandwidth could also be useful in overcoming enemy jamming and other forms of noise and/or propagation anomalies.

The desired message would be composed by the FAC or ALO at the point of message origin and might be sent in the form of a burst of information over a period of perhaps one to possibly ten seconds, depending on the available signal-to-noise ratio. The choice of

* Such devices are presently being investigated at RAND. ITT Federal Laboratories (San Fernando, California) has built and is testing such devices. The Stromberg-Carlson Division of General Dynamics and other electronic manufacturers have built similar prototype devices.

transmission time (whether it be a burst of one second or ten seconds) might be varied automatically, depending on the acknowledgment signals received in return at the message source, or it could be controlled manually by the sender. (This suggests the varying levels of sophistication that the Coding/Decoding/Acknowledging device might have.)

PHASE I

Assuming that a command structure comparable to that of today is used in the post-1972 period, then, typically, coded digital messages would go from an FAC to the DASC, with monitoring at brigade, division, and corps CPs. Messages would be converted manually by the same communication operators who today laboriously hand-copy voice messages.

It appears that the use of CDA devices would require no additional personnel, nor would it initially necessitate appreciable change from the present mode of message handling.

Introducing CDA devices throughout the entire command control and communication structure would yield several improvements, among them at least the following:

- a) reduction of errors in message transmission
- b) increase in total information rate
- c) acquisition of valuable field experience in working with digital communications.

Any deleterious effects that might be encountered in converting from the present system to the Phase I system would be mitigated by the requirement that all digital transmissions use communication channels capable of handling voice traffic as a backup mode. Thus, continuity of operations would not be lost in the event of malfunction of CDA equipment.

Cost of acquiring CDA devices has been estimated to be as little as \$1000 per unit for relatively simple devices. Added sophistication could easily double or triple this cost, but the added complexity could buy improvements in accuracy, security, and flexibility of

operation. As a very rough rule of thumb, the cost of acquiring about 25-30 CDA devices to support a division in the field might range from about \$30,000 to \$100,000.

PHASE II

An improved Phase II system might employ a device to automatically buffer and decode the message and generate a hard-copy printed output. Thus, a lightweight, reliable, rugged printer suitable for field use would be required at higher levels of command such as corps and division, and possibly at brigade.

It might be desirable to have associated with the printer a format message composer.* The received message would automatically select the proper stored message format so that the hard-copy output would include both "message" information and "format" information. Since the message rate handled at brigade level would be relatively small, it remains to be determined whether a format message composer is needed there.

PHASE III

A Phase III system would include electronic data processing of the received message; the computers involved might have the additional task of controlling output displays. In the early stage of the Phase III system, simple displays making use of computer-generated hard copy information might be used. For example, hard copy in the form of typed symbols on clear plastic might be generated by the computer and displayed with some form of VU-Graph projector. Of course, for simplicity there could be human intervention between hard-copy generation and the display device. Even this relatively unsophisticated system would be better than the present "manned grease pencil" in use today.

* A format message composer, with a capacity of 200 separate formats, is employed in the 465L system today.

"Small" computers to process message information might be introduced at the division command level. The computer suggested for division CP use is intended primarily to assist the division commander (or an appropriate staff member) in deciding whether an air support request is a valid one or whether the request should be satisfied by organic Army resources. This computer may be provided by the Air Force or furnished as part of the Army command control system, since most of the data would pertain to the division's organic fire support capability.*

At corps command level, a "medium" capability computer could be used to assist some of the Air Force staff planning and decision-making performed in the DASC. Obviously, it would be wise to have a comparable capability to assist Army operations in the TASE.

Similar medium capability computers would probably be in use at the TACC/AFFCP. In the CRC and CRP at least a small computer would probably be required; possibly a medium capability computer would be necessary. A medium capability computer probably would be required in the joint operation center.

Displays of varying degrees of complexity and capability are required in all these command elements. Further improvements in computer-driven display capability obviously will dictate the degree of sophistication warranted here. However, early acquisition of simple computer-driven displays should not be delayed by the requirement for field-service multi-color displays.

It is emphasized that the computers discussed above are assumed to be relatively small (micro-miniaturized), solid-state, rugged computers probably similar to those used in today's ICBMs. Such computers might weigh about 50 to 100 lb and have a volume of approximately 1 to 3 cu ft. Power requirements are likely to be no more than 200-300 watts. The Nortronics NDC-1000 and the Autonetics Monica-C are examples of some of the presently available computers fitting this description.

*We assume that prior to 1972, Army, Navy, and Air Force command, control, and communication digital equipment in the field will be highly compatible. Furthermore, it is not germane to this discussion which armed service provides computer capability at the division level.

We would expect the computer "software" to be essentially "cast in concrete," i.e., typically it might consist of a secure, wired drawer that can be inserted into the basic computer structure, thus converting that computer for use at a particular command level, such as division or corps. The wired drawer concept would provide an opportunity to take advantage of the reduced cost, increased speed, and increased reliability that accrue through the use of "read-only stores."* By the use of interchangeable read-only store sections (software drawers) computers could be converted for use in various functional areas such as air traffic control, close air support, etc., as well as serving at various levels of command in other roles. Probably, drawers should not be modified in the field, although it should be possible to exchange them.

We also suggest that it might be useful to have a communications satellite terminal at the joint task force level of command. This would facilitate coordination of data processing at the joint task force level with that occurring in the ZI, such as at STRICOM, TAC Headquarters, and other appropriate command levels. If these ZI-based organizations are kept apprised of pertinent major events as they transpire, these commands can then be prepared to carry out important staff planning and control actions in anticipation of requests from the joint task force commander or by higher elements of command such as the Joint Chiefs of Staff.

To give a more succinct overview, Table 2 indicates the progressive phases of the outlined program. Figure 4 shows the additional equipment suggested by the end of Phase III for the situation as outlined in Fig. 1, p. 5. (The dashed-line boxes in Fig. 4 indicate uncertainty with regard to which service provides the computer capability.)

*The read-only store section of a computer may include some permanently wired subroutines, programs, and program constants. It provides non-destructive readout, in addition to higher speed and reliability. Some computers are capable of accepting punched metal cards as inputs to the read-only store.

Table 2

A PROGRAM OUTLINE FOR THE CODED MESSAGE CONCEPT OF AN ADVANCED
TACTICAL AIR CONTROL SYSTEM

Command Level	System Components				
	Digital Communications (Voice backup)	Message Converter; Printer	Format Message Composer	Computer, Displays	Comsat Terminal
Battalion (TACP ₁)	Phase I				
Brigade (TACP ₂)	Phase I	Phase II			
Division (TACP ₂)	Phase I	Phase II	Phase II	Phase III	
Corps (DASC)	Phase I	Phase II	Phase II	Phase III	
JTF (AFFCP) (TACC) (CRC) (CRP) (FACP) (ASRT) (RP)	Phase I	Phase II	Phase II	Phase III	Phase III

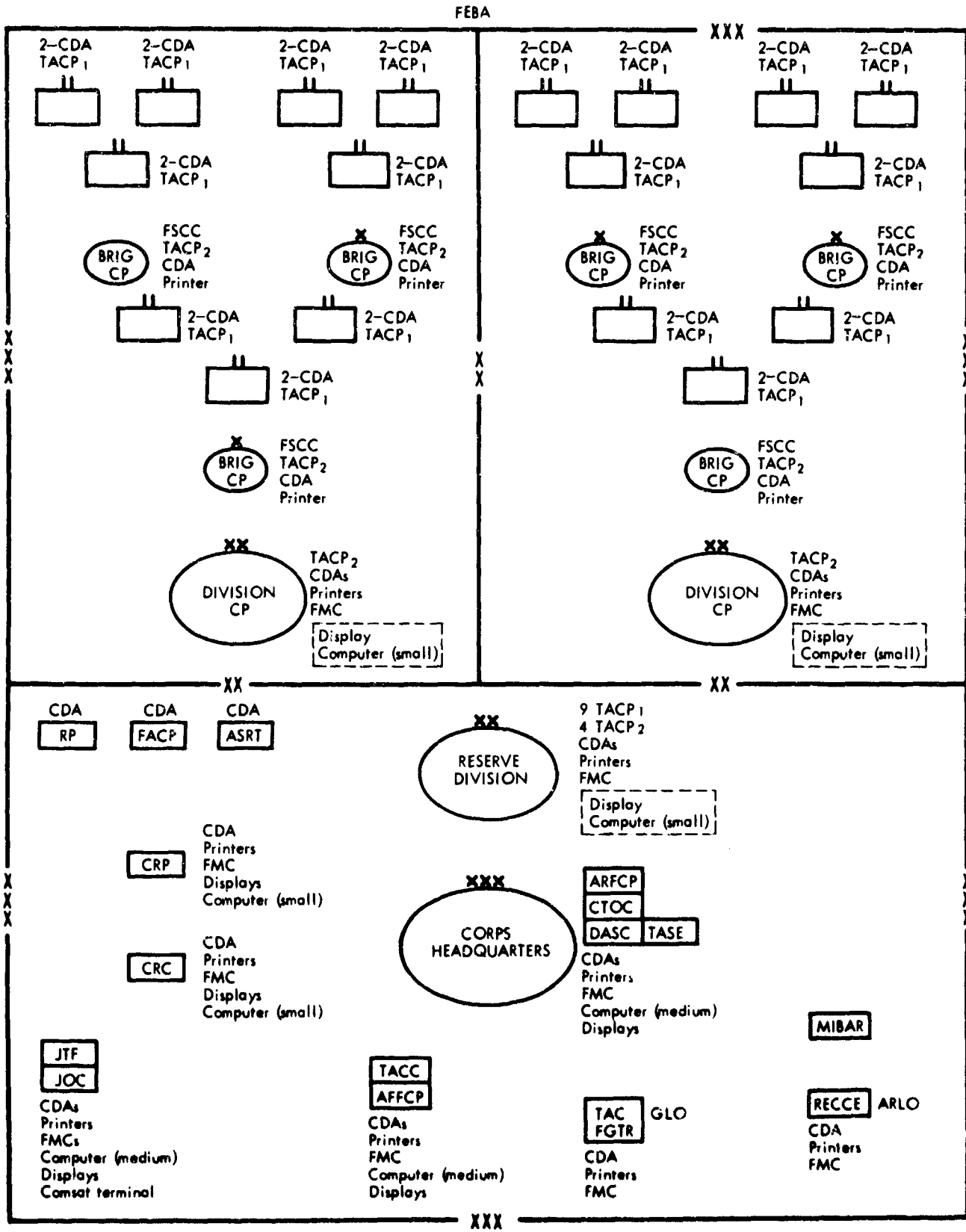

- JTF : Joint Task Force
- JOC : Joint Operations Center
- AFFCP : Air Force Forces Command Post
- ARFCP : Army Forces Command Post
- TACC : Tactical Air Control Center
- CTOC : Corps Tactical Operations Center
- DASC : Direct Air Support Center
- TASE : Tactical Air Support Element
- MIBAR : Military Intelligence Battalion (Airborne Reconnaissance)
- FSCC : Fire Support Control Center

- FACP : Forward Air Control Post
- ASRT : Air Support Radar Team
- RP : Reporting Post
- CRP : Control & Reporting Post
- CRC : Control & Reporting Center
- GLO : Ground Liaison Officer
- ARLO : Airborne Reconnaissance Liaison Officer
- TACP₁ : ALO + FAC + Communication Personnel
- TACP₂ : ALO + Communication Personnel
- CDA : Coding/Decoding/Acknowledging
- FMC : Format Message Composer

Fig. 4—Coded message concept for an Advanced Tactical Air Control System

V. OTHER FACETS OF THE PROBLEM

APPLICABILITY

The discussion presented thus far has centered primarily about the task of transmitting, receiving, and processing immediate requests for close air support. This one application of such a method of generating, transmitting, and processing messages in coded digital form is by no means the limit of applicability of either the equipment or the techniques. The same process can be applied to the task of interchanging information concerning preplanned requests; it can be used in the exchange of messages among the TACC, the DASC, and the CRC and CRP, with the AFFCP "capping" the entire Air Force tactical operation. The concept is applicable to other functional areas, as noted elsewhere in the Memorandum.

A system employing Coding/Decoding/Acknowledging devices could be applied to the task of information exchange between pilots in aircraft and the forward air controllers.* The display equipment in the aircraft--probably in the form of "Nixie" tubes or mechanical, numbered dials--could also be used in conjunction with a ground beacon transponder system, affording an element of air control in drop zones, etc.

We wish to stress again that this Memorandum's description of a suggested mode of operation is intended only as a vehicle of discussion, placed in the context of a pressing problem of the present. A wide variety of applications of the concept are readily apparent.

INTER-SERVICE COMPATIBILITY

The coded message concept of an Advanced Tactical Air Control System for the post-1972 period as outlined should obviously be implemented only with close cooperation among the Air Force, Army,

* A portion of RAND's interest in CDA devices has been directed to this end.

Navy, and Marine Corps. Cooperation and (equipment) compatibility are essential because of the highly probable occasions when all services would operate together under a single joint task force command. Compatibility of message format, digital word structure, communications equipment, staff planning techniques, and so forth would be of prime importance.

SECURITY

Message security is always important in any command control system. By converting the message into digital form at the point of origin, vast improvements can be made in message security with respect to today's voice communications methods. Cryptographic keys can be designed for the CDA devices used throughout the suggested command, control, and communication system discussed herein. These keys could be changed periodically in order to combat an enemy's ability to break the code and make timely use of message information.

VI. CONCLUSIONS

This three-phase program for acquiring an Advanced Tactical Air Control System for post-1972 operations is predicated on the basis of an evolutionary growth schedule that calls for the acquisition of the least expensive (but conceptually most important) items first: the CDA devices to be used at the points of message origin and destination. We suggest that these devices could be made available within two years or less and that their introduction into the present TACS could markedly improve system operation, in addition to providing a firm base upon which to develop requirements for the more sophisticated elements of the proposed system.

Future changes in weapons systems and ground warfare tactics will doubtless call for modifications in the present TACS structure. But the fundamental need to rapidly and accurately transmit and receive messages and perform data processing also will doubtless remain, and probably will continue to grow in importance. Use of digital techniques has already been established in the fields of communication and data processing. It now remains to apply these techniques to the tactical air control task in a suitable evolutionary fashion to gain continuing improvements.