

AD615737

WT-14

OPERATION PLUMBBOB



NEVADA TEST SITE
MAY-OCTOBER 1957

Chic. 26
TECHNICAL LIBRARY
884/6
27 MAY 1965
DEFENSE ATOMIC
SUPPORT AGENCY

Project 3.3

EVALUATION OF BURIED CORRUGATED-STEEL ARCH
STRUCTURES AND ASSOCIATED COMPONENTS

Issuance Date: February 22, 1961

HEADQUARTERS FIELD COMMAND
DEFENSE ATOMIC SUPPORT AGENCY
SANDIA BASE, ALBUQUERQUE, NEW MEXICO

COPY 2 OF 3
HARD COPY \$.40
MICROFICHE \$.07

DDC
JUN 7 1965
DDC-RA E

ARCHIVE COPY

WT-1422

OPERATION PLUMBBOB—PROJECT 3.3

**EVALUATION OF BURIED CORRUGATED-STEEL ARCH
STRUCTURES AND ASSOCIATED COMPONENTS**

**G. H. Albright, LTJG, CEC, USNR
Project Officer**

E. J. Beck

J. C. LeDoux, LCDR, CEC, USN

R. A. Mitchell, LTJG, CEC, USNR

**Bureau of Yards and Docks
Navy Department
Washington 25, D. C.**

**U. S. Naval Civil Engineering Laboratory
Port Hueneme, California**

THIS REPORT HAS BEEN APPROVED FOR OPEN PUBLICATION.

DISCLAIMER NOTICE

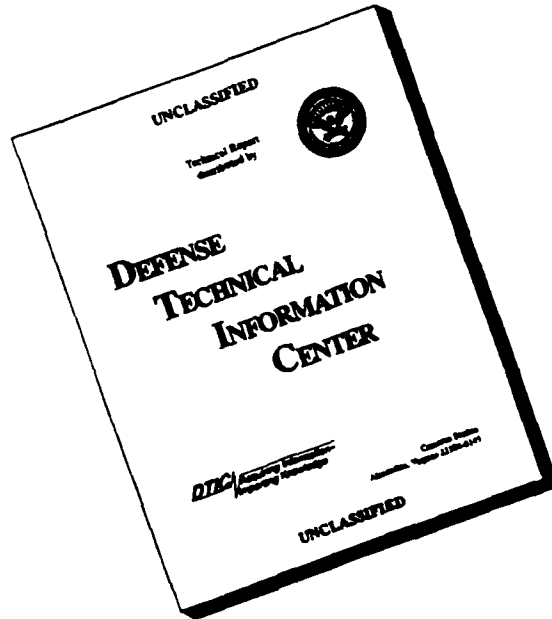

**THIS DOCUMENT IS BEST
QUALITY AVAILABLE. THE
COPY FURNISHED TO DTIC
CONTAINED A SIGNIFICANT
NUMBER OF PAGES WHICH DO
NOT REPRODUCE LEGIBLY.**

BLANK PAGE

ABSTRACT

Three underground corrugated-steel arch structures covered with 5 feet of earth were subjected to peak overpressures of 60 and 100 psi during Shot Priscilla at the Nevada Test Site. Essentially, it was desired to assure that Department of Defense Class II (50-psi overpressure and comparable radiations) protection is afforded by two types of 25-foot diameter, 180-degree corrugated-metal arches.

Free-field overpressure was measured at the ground surface above the structures, along with pressure inside each structure, acceleration of the floor slab, arch deflection relative to the floor slab, and gamma and neutron radiation dose inside each structure. Dust was measured inside one structure.

All arch structures provided adequate Class II protection for the conditions of the test. One arch structure, reinforced with steel arch ribs, withstood 100-psi overpressure (333-msec positive-phase duration) with no significant damage other than a cracked floor slab.

A blast closure valve was tested in the ventilating system of one structure. Operation was satisfactory during the positive-pressure phase, but the valve leaked excessively during the negative-pressure phase.

Prototype pits designed to partially shield emergency power generator sets against blast, missiles, and thermal radiation damage were tested to determine their adequacy. Damage assessment indicated significant but inadequate protection at the overpressures to which the generator sets were exposed.

FOREWORD

This report presents the final results of one of the projects comprising the military-effect programs of Operation Plumbbob, which included 24 test detonations at the Nevada Test Site in 1957.

For overall Plumbbob military-effects information, the reader is referred to the "Summary Report of the Director, DOD Test Group (Programs 1-9)," ITR-1445, which includes: (1) a description of each detonation, including yield, zero-point location and environment, type of device, ambient atmospheric conditions, etc.; (2) a discussion of project results; (3) a summary of the objectives and results of each project; and (4) a listing of project reports for the military-effect programs.

PREFACE

The pretest planning, field test, and completion of the interim test report was accomplished by the Bureau of Yards and Docks (BUDOCKS) with assistance in the field by the research staff of the U. S. Naval Civil Engineering Laboratory (NCEL). The project was conceived, planned, and executed under the guidance of CAPT A. B. Chilton, Jr., CEC, USN, who was then Manager of the Atomic Energy Branch of BUDOCKS. LTJG G. H. Albright, CEC, USNR, was Project Officer and Writer of the interim test report. W. A. Shaw was Project Engineer for the NCEL participation at the test site.

This report was prepared by the research staff of NCEL.

The following agencies and projects made essential contributions to the total success of this project:

Chemical Warfare Laboratories, Project 2.4, Radiation Shielding
Ballistic Research Laboratories, Project 3.7, Structural Instrumentation
Waterways Experiment Station, Project 3.8, Soils Survey
Lookout Mountain Laboratory, Project 9.1, Photography
Lovelace Foundation for Medical Education and Research, Project 33.5, Dust Investigation

CONTENTS

ABSTRACT	5
FOREWORD	6
PREFACE	6
CHAPTER 1 INTRODUCTION	11
1.1 Objectives	11
1.2 Relationship of Project Objectives	11
CHAPTER 2 TEST OF CORRUGATED-STEEL ARCH STRUCTURES	13
2.1 Objectives	13
2.2 Background and Theory	13
2.3 Procedure	14
2.3.1 Description of Structures	14
2.3.2 Structural Data Requirements	15
2.3.3 Environmental Data Requirements	15
2.3.4 Radiation Data Requirements	15
2.4 Results	16
2.4.1 Structural Measurements	16
2.4.2 Environmental Observations	17
2.4.3 Radiation Measurements	17
2.5 Discussion	17
2.5.1 Structural Adequacy of Arches	17
2.5.2 Suitability of Internal Environment	19
2.5.3 Nuclear Radiation Shielding Effectiveness	20
2.6 Conclusions	20
2.7 Recommendations	21
CHAPTER 3 TESTS OF BLAST CLOSURE VALVE	26
3.1 Background	26
3.2 Procedure	26
3.3 Results	26
3.4 Discussion	26
3.5 Conclusions	26
3.6 Recommendations	26
CHAPTER 4 PIT ENCLOSURES FOR EMERGENCY POWER GENERATORS	24
4.1 Background	24
4.2 Procedure	24
4.3 Results	24
4.4 Discussion	25
4.5 Conclusions	25
4.6 Recommendations	25

APPENDIX A CONSTRUCTION	71
A.1 Responsibilities	71
A.2 Construction Details	71
A.2.1 Structures	71
A.2.2 Equipment	76
A.3 Soil-Survey Program	76
A.3.1 Soil Data	76
A.3.2 Backfill Operations	77
APPENDIX B STRUCTURE INSTRUMENTATION	89
B.1 Deflection Gage	89
B.2 Self-Recording Pressure-Time Gage	89
B.3 Peak-Pressure Gage	90
B.4 Dynamic Accelerometers	90
B.4.1 Electronic Accelerometer	90
B.4.2 Self-Recording Accelerometers	91
B.5 Peak Accelerometer	91
B.6 Dust Collectors	92
APPENDIX C RADIATION INSTRUMENTATION	100
C.1 Background and Theory	100
C.2 Description of Instrumentation	100
C.2.1 Gamma Film Packets	100
C.2.2 Chemical Dosimeters	101
C.2.3 Neutron-Threshold Devices	101
C.3 Instrumentation Layout	102
C.4 Results and Discussion	102
C.5 Conclusions	103
REFERENCES	107
TABLES	
1.1 Arrangement of Structures, Shot Priscilla	12
2.1 Summary of Corrugated-Steel Structure Tests	22
2.2 Properties of Corrugated-Steel Plates	22
2.3 Structural Instrumentation	23
2.4 Structural Measurements	23
2.5 Survey Measurements	24
2.6 Radiation Measurements	25
4.1 Tabulation of generator damage	67
A.1 Sand Density Tests	79
A.2 Chemical and Spectrographic Analysis of Backfill	79
C.1 Free-Field Gamma and Neutron Measurements	103
C.2 Gamma Shielding Characteristics of Project 3.3 Structures, Frenchman Flat, Shot Priscilla	103
C.3 Neutron Shielding Characteristics of Project 3.3 Structures, Frenchman Flat, Shot Priscilla	104
FIGURES	
1.1 Plot plan	12
2.1 Earth configuration for Structure 3.15, Operation Upshot-Knothole	26

2.2 Earth configuration for Structure 3.6, Operation Teapot	27
2.3 Modified earth configuration for Structure 3.15, Operation Teapot	28
2.4 Earth configuration for Structure 3.3, Operation Plumbbob	29
2.5 End bulkhead	30
2.6 Shelter entrance	31
2.7 Submarine-type hatch cover (open)	32
2.8 Submarine-type hatch cover (closed)	32
2.9 Plan of entrance trunk at tunnel	33
2.10 Plan and section of Structure 3.2a	33
2.11 Erection of corrugated plate on steel arch rib, Structure 3.3a	34
2.12 Front view prior to backfilling, Structure 3.3a	34
2.13 Rear view prior to backfilling, Structure 3.3a	35
2.14 Interior view, Structure 3.3a	35
2.15 Plan and section of Structure 3.3b	36
2.16 Top view prior to backfilling, Structure 3.3b	36
2.17 Access entrance during construction, Structure 3.3b	37
2.18 Completed earth cover, Structure 3.3b	37
2.19 Interior view, Structure 3.3b	38
2.20 Plan and section of Structure 3.3c	38
2.21 Steel arch ribs, Structure 3.3c	39
2.22 Overall view prior to backfilling, Structure 3.3c	39
2.23 Access entrance during construction, Structure 3.3c	40
2.24 Interior view, Structure 3.3c	40
2.25 Gage location	41
2.26 Recovery tube prior to backfilling	41
2.27 Flexible hose in recovery tube	42
2.28 Deflection records at rib, Structure 3.3a	42
2.29 Deflection records at crown, Structure 3.3a	43
2.30 Deflection records, Structure 3.3b	43
2.31 Deflection records at rib, Structure 3.3c	44
2.32 Deflection records at crown, Structure 3.3c	44
2.33 Footing position on blast side of Structure 3.3a (preshot)	45
2.34 Footing position on blast side of Structure 3.3a (postshot)	45
2.35 Footing position on leeward side of Structure 3.3a (preshot)	46
2.36 Footing position on leeward side of Structure 3.3a (postshot)	46
2.37 Blast side of Structure 3.3a showing crack in floor slab (postshot)	47
2.38 Crack pattern of floor, Structure 3.3a	47
2.39 Corner view of Structure 3.3a (preshot)	48
2.40 Corner view of Structure 3.3a (postshot)	48
2.41 Earth-cover configuration of Structure 3.3a (preshot)	49
2.42 Earth-cover configuration of Structure 3.3a (postshot)	49
2.43 Footing position on blast side of Structure 3.3b (preshot)	50
2.44 Footing position on blast side of Structure 3.3b (postshot)	50
2.45 Corner view of Structure 3.3b (preshot)	51
2.46 Corner view of Structure 3.3b (postshot)	51
2.47 Footing position on blast side of Structure 3.3c (preshot)	52
2.48 Footing position on blast side of Structure 3.3c (postshot)	52
2.49 Footing position on leeward side of Structure 3.3c (preshot)	53
2.50 Footing position on leeward side of Structure 3.3c (postshot)	53
2.51 Earth-cover configuration of Structure 3.3c (preshot)	54
2.52 Earth-cover configuration of Structure 3.3c (postshot)	54
2.53 Metal closure at equipment-room concrete bulkhead, Structure 3.3c (preshot)	56

2.54 Metal closure at equipment-room concrete bulkhead, Structure 3.3c (postshot) - - - - -	55
2.55 Metal closure at equipment-room concrete bulkhead, Structure 3.3c (preshot) - - - - -	56
2.56 Metal closure at equipment-room concrete bulkhead, Structure 3.3c (postshot) - - - - -	56
2.57 Ventilation pipe and lighting fixture, Structure 3.3c (preshot) - - - - -	57
2.58 Ventilation pipe and lighting fixture, Structure 3.3c (postshot) - - - - -	57
2.59 Water and ventilation pipes above Structure 3.3c (preshot)- - - - -	58
2.60 Water and ventilation pipes above Structure 3.3c (postshot) - - - - -	58
3.1 Pressure plenum for blast closure valve test - - - - -	61
3.2 Blast closure valve installed in test plenum - - - - -	62
3.3 Blast closure valve test plenum air intake and access hatch after backfilling - - -	62
3.4 Schematic representation of blast closure valve - - - - -	63
4.1 Test pit, 15-kva generator set - - - - -	68
4.2 Test pit, 5-kva generator set- - - - -	68
4.3 Generator protective pit with grating in place - - - - -	69
4.4 Postshot view of generator pit - - - - -	69
4.5 Postshot view of generator in pit, with pit grating removed - - - - -	69
4.6 Postshot view of generator without sheet-metal shrouding, with pit grating removed - - - - -	70
A.1 Arch rib and entrance details - - - - -	80
A.2 Ventilation details - - - - -	81
A.3 Structural and architectural details - - - - -	82
A.4 Entrance-hatch details - - - - -	83
A.5 Mechanical and electrical details - - - - -	84
A.6 Details of recovery tube for neutron-threshold device - - - - -	85
A.7 Assembly of steel ribs, Structure 3.3c - - - - -	86
A.8 Form work for interior concrete bulkhead, Structure 3.3c - - - - -	86
A.9 Soil-survey compaction test report- - - - -	87
A.10 Tamper compaction pattern - - - - -	88
A.11 Compacting backfill with vibrating roller - - - - -	88
B.1 Scratch-type deflection gage attached to arch ribs - - - - -	93
B.2 Scratch-type deflection gage attached to corrugated-steel plate - - - - -	93
B.3 Model P-3.3 scratch gage - - - - -	94
B.4 Scratch-gage platform (rear view) - - - - -	94
B.5 Self-recording pressure-time gage- - - - -	95
B.6 Self-recording pressure-time gage mounted in concrete base - - - - -	95
B.7 Self-recording pressure-time gage mounted inside blast closure valve plenum- - - - -	96
B.8 Recorded overpressure versus time on ground surface at Structure 3.3b- - - - -	96
B.9 Peak-pressure gage- - - - -	97
B.10 Calibration of electronic accelerometers - - - - -	97
B.11 Electronic accelerometer in place - - - - -	98
B.12 Self-recording accelerometer (right)- - - - -	98
B.13 Peak accelerometer attached to crown of structure - - - - -	99
B.14 Dust collector - - - - -	99
C.1 Location of radiation detectors in Structure 3.3c- - - - -	105
C.2 Location of radiation detectors in Structures 3.3a and 3.3b- - - - -	106

Chapter 1

INTRODUCTION

1.1 OBJECTIVES

The test effort was concentrated on three basic components of a personnel shelter—the shelter structure, the blast closure valve, and the electric power source. The objectives were to: (1) determine the degree of protection from blast and radiation afforded by earth-covered, corrugated-steel arch structures, (2) determine the blast capabilities of a blast closure valve, and (3) determine the suitability of open pits for blast protection of power generators.

Two types of 25-foot-diameter, 180-degree arch structures, the E19R1 blast closure valve, and two types of pit enclosures for power generators were tested during Shot Priscilla at the Nevada Test Site (NTS). Figure 1.1 shows the layout of structures, blast closure valve plenum, and generator pits at the test site. Table 1.1 gives the range of structures from ground zero and the predicted theoretical overpressure at the structures.

1.2 RELATIONSHIP OF PROJECT OBJECTIVES

A shelter satisfactory for personnel occupancy for several days or weeks must perform several basic functions. It must provide a volume of space free from blast overpressure, missiles, prompt radiation, and residual or fallout radiation. It must also provide a suitable air supply, water supply, waste disposal, lighting, and storage space for food and other items.

A blast closure valve in the entrance and exhaust of the ventilating system is necessary to prevent damage to the system and other shelter contents.

Electric power is required for the ventilating or air-conditioning equipment, lighting, and possibly for heating, cooking, pumping, and communications.

TABLE 1.1 ARRANGEMENT OF STRUCTURES, SHOT PRISCILLA

Yield: 36.6 kt. Height of burst: 700 ft.

Structure	3.3a	3.3c	3.3b
Station number	9019.01	9019.02	9019.03
Range from ground zero to center of structure, ft	1,150	1,363	1,360
Slant range, yds	449	510	510
Angle of sight, deg	31	27	27
Topographic coordinates	N 746,877.74 E 715,037.10	N 746,881.72 E 714,796.31	N 747,111.67 E 714,948.56
Predicted theoretical overpressure at earth surface, psi	75	50	50

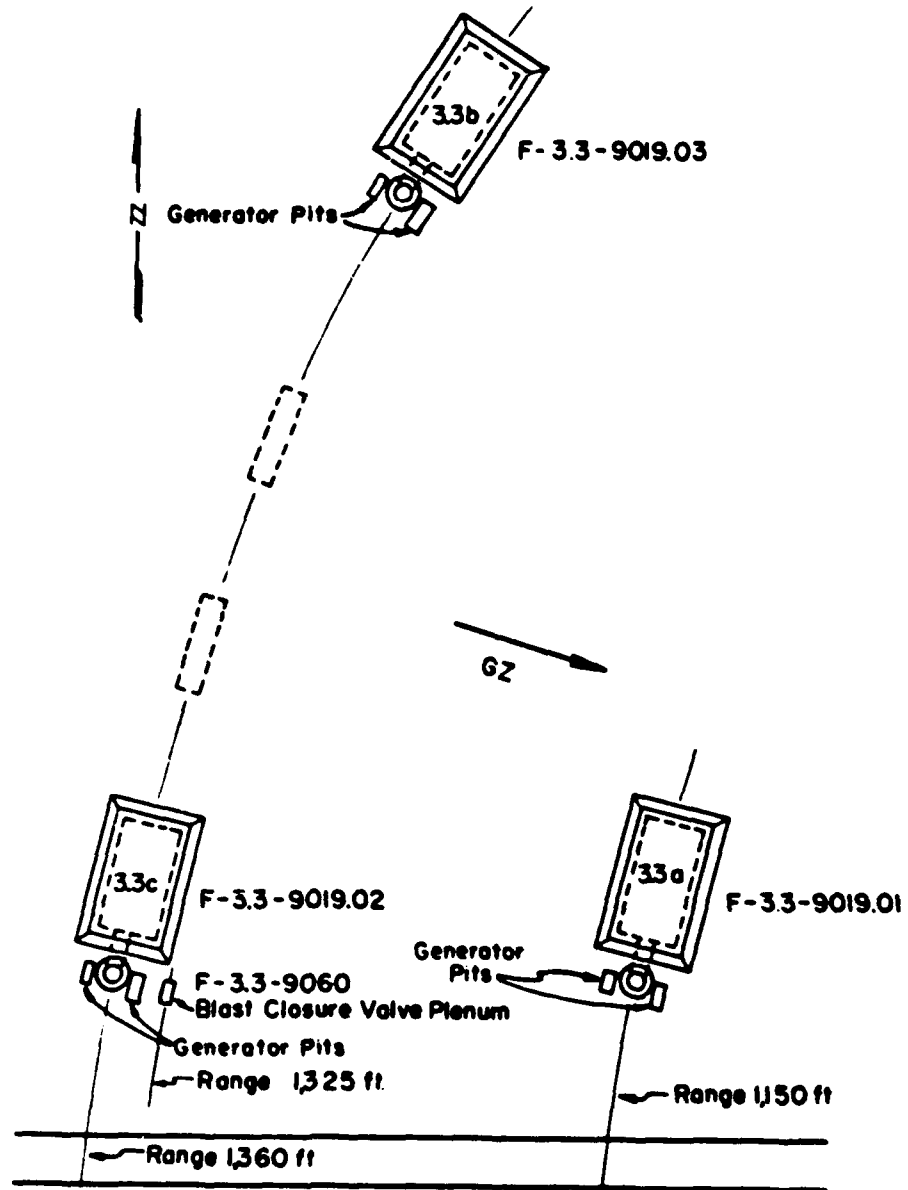

Figure 1.1 Plot plan.

Chapter 2

TEST OF CORRUGATED-STEEL ARCH STRUCTURES

2.1 OBJECTIVES

The general purpose of this test was to determine the protection from blast and nuclear radiation afforded by 25- by 48-foot earth-covered corrugated-steel arch structures used as personnel shelters. The structures were modified prefabricated ammunition-storage magazines.

The specific objectives were to: (1) assure that Department of Defense (DOD) Class II (50-psi) protection is afforded by such shelters, and (2) determine the increased protection afforded by the addition of strengthening members (steel-arch ribs).

2.2 BACKGROUND AND THEORY

Past tests and studies have indicated that the use of earth-covered prefabricated ammunition-storage magazines is a relatively inexpensive and adequate method of providing personnel shelters. The corrugated-steel magazines tested in Operations Upshot-Knothole and Teapot were similar to those tested in Operation Plumbbob and are, therefore, of particular interest here.

The earth configuration used for Structure 3.15 in Operation Upshot-Knothole is shown in Figure 2.1. Analysis showed this type of surface structure was very sensitive to asymmetrical loading (Reference 1). The dynamic pressure acting on the structure during Operation Upshot-Knothole has been roughly estimated at 5 psi. A dynamic pressure of 50 to 80 psi was predicted for Operation Teapot. A different earth-cover configuration was, therefore, used for Structure 3.6 in Operation Teapot (Figure 2.2). During Operation Teapot, Structure 3.15 was retested with the earth configuration changed from that shown in Figure 2.1 to that shown in Figure 2.3. Results of Operations Upshot-Knothole and Teapot are summarized in Table 2.1.

The following conclusion is quoted from Reference 1: "The structure and configuration tested (Building 3.6) would serve as an adequate shelter under conditions in the open not exceeding any of the following conditions: average side-on pressure, 30 psi; average dynamic pressure, 80 psi; and total flux prompt radiation, 10,000 r. Actually, the structure would probably withstand a still larger side-on pressure if the coincidental dynamic pressure were sufficiently small." Reference 1 recommends, "To obtain maximum blast protection with a given thickness of earth cover and at a minimum cost, the shelter should be partially buried so that the volume of the cut approximates the volume of the fill."

Based upon the Upshot-Knothole and Teapot results, the earth configuration was further modified to reduce the dynamic pressure sensitivity for this test (Figure 2.4). This configuration was based upon a balanced cut-and-cover procedure, with the berm extending along the earth surface to the intersection of an approximate 45-degree line from the base of the structure. On the basis of the modified earth cover, it was estimated that the structure would withstand approximately a 50-psi side-on overpressure at the earth surface.

Reference 2 indicates that the theoretical collapsing pressure computed by a rigorous analysis is an underestimate by a wide margin of the capacity of the structure. It was also estimated that the collapsing pressure for this structure would be not less than 50 psi.

It was planned that the evaluation of the three structures as personnel shelters would be based on the results of instrumentation, including maximum dynamic deflections, internal peak pressures, vertical accelerations of the floor, neutron- and gamma-radiation levels, and post-shot surveys and examinations.

2.3 PROCEDURE

2.3.1 Description of Structures. Three earth-covered, (balanced cut-and-cover) prefabricated ammunition-storage magazines, with the earth configuration shown in Figure 2.4, were located for Shot Priscilla as indicated in Table 1.1 and Figure 1.1.

All three structures basically consisted of Navy stock 25- by 48-foot ammunition-storage magazines (Navy Yards and Docks Supply No. C-59-M-50) with certain modifications. Those modifications common to all three structures are described first, and those unique to each structure will be described in subsequent paragraphs of this section.

The curved sections consisted of 10-gage corrugated-steel plates having the properties (Reference 3) described in Table 2.2. Other gages are listed in Table 2.2, because they were used for certain end bulkheads.

The stock access-end bulkheads were not used in any of the three test structures but were replaced with corrugated end-bulkheads of a gage equal to that used on the rear end-bulkheads.

The end bulkheads on all structures were additionally reinforced by a tickback and deadman arrangement (Figures 2.5 and 2.6). The standard, 8-gage rear bulkhead was used in Structure 3.3b, but 3-gage end bulkheads were used for Structures 3.3a and 3.3c.

The backfilling operations followed conventional construction practices. The soil used for backfill was hauled to the site from a gravel pit located 4 miles from the lakebed area of the test site. A gravelly, silty sand was used, rather than the silt of the dry lakebed of Frenchman Flat, in order to more typically represent an installation such as may be found at continental United States and oversea base locations. Descriptions of the soil used, analyses performed, and backfilling procedure are presented in Appendix A.

The same entrance configuration was used for each of the three test shelters. This consisted of a horizontal, corrugated 8-gage steel tube 7 feet in diameter, with a vertical access trunk of 8-gage corrugated steel, 3 feet 6 inches in diameter, resting on a concrete pad (Figure 2.6). At the ground surface, a submarine-type circular hatch (Figures 2.7 and 2.8) served as a blast door. A detailed description is given in Appendix A. These entrances were designed primarily to facilitate testing operations and were not intended as a prototype of an operational personnel shelter. In the entrance, sandbags were placed against the vertical tube (in the horizontal passage) to provide greater shielding against nuclear radiation entering through the closed steel hatch cover (Figure 2.9).

The deck of all three structures consisted of a 4-inch concrete slab separated from the foundation walls by a $\frac{1}{2}$ -inch, impregnated, expansion-joint filler. This joint was intended to serve three purposes: (1) Acceleration forces transmitted to the structural shell ribs and footings would not be transmitted to personnel standing on the floor slab. (2) A relatively economical (thin) floor slab could be used, inasmuch as all vertical earth-pressure reactions to the structure proper are independent of the floor slab. (3) A significant displacement of the footings relative to the floor could be permitted without considerable cracking of the floor slab and without affecting the dead-load capacity of the structure.

Construction details for all three structures are included in Appendix A.

Structure 3.3a was a stock magazine modified as follows: the rear and access-end bulkheads were 3-gage corrugated plate additionally supported by tiebacks and deadmen, and steel curved-arch ribs were placed at 4-foot intervals. The basic plan and a sectional view are shown in Figure 2.10. Photographs showing details of the assembly of the structure are presented in Figures 2.11 through 2.14.

Structure 3.3b was a stock magazine modified as follows: the access-end bulkhead was an 8-gage corrugated-steel plate additionally supported by tiebacks and deadmen, and the rear bulkhead was a stock end-bulkhead of 3-gage corrugated-steel plate additionally supported by tiebacks and deadmen. The basic plan and a sectional view are shown in Figure 2.15. Photographs showing details of the assembly of the structure are presented in Figures 2.16 through 2.19.

Structure 3.3c was a stock magazine modified as follows: the rear and access-end bulkheads were 3-gage corrugated plate additionally supported by tiebacks and deadmen, and steel curved-

arch ribs were placed at intervals of 4 feet. The basic plan and a sectional view are shown in Figure 2.20. Photographs showing details of the assembly of the structure are presented in Figures 2.21 through 2.24.

The interior of Structure 3.3c was completely arranged as a personnel shelter to permit a valid evaluation with respect to radiation shielding. This consisted of a typical partition arrangement that would normally be installed in a shelter requiring protection against atomic, biological, or chemical attack. Airlocks and provision for a collective protector and blast closure valves were included. An 8-inch and a 22-inch ventilation stack were installed to permit prompt radiation to enter the structure, a situation occurring in an actual installation. However, for this test case, the stacks were sealed with a steel plate to prevent blast pressure from entering; this plate simulated the radiation penetrability of a blast closure valve, so that typical radiation levels could still be approximated.

Miscellaneous typical sections of water piping, fittings, and valves were also included in Structure 3.3c to determine what structural damage would occur to such items by vertical movement of the structure and by shock transmitted to them. Typical electric wiring and lighting fixtures were installed to establish an index of damage to such equipment. Detailed drawings are included in Appendix A.

2.3.2 Structural Data Requirements. The structural instrumentation consisted of the measurement of transient air pressures, peak internal pressures, maximum and dynamic accelerations—all by Ballistic Research Laboratories (BRL) Project 3.7—and measurement of deflections (utilizing scratch gages) by the U. S. Naval Civil Engineering Laboratory (NCEL). A summary of structural instrumentation is given in Table 2.3, and the locations of the gages are shown in Figure 2.25. Data reliability, description of instruments, and conclusions regarding instrumentation are presented in Appendix B.

In order to determine the deformations that the structures experienced because of the dead load (soil backfill) and the displacement of the footings because of dynamic loads, measurements were taken at time of backfilling, at 11 days preshot, and at 8 days postshot. Measurements included the cross-section shape of the structure and earth cover. The specific locations and magnitudes of such measurements are indicated in Section 2.4.1.

2.3.3 Environmental Data Requirements. Particular attention was given to those items defined as personnel environmental hazards inside closed underground structures: acceleration effects, internal-pressure effects, missile hazards, and dust hazards. Accelerometers were mounted on the floor slabs to provide both peak-acceleration and dynamic-acceleration records. Peak-pressure gages were installed in each structure to serve not only as a check for structural behavior due to leakage but also as a check for pressure hazard to personnel. Photographs served as documentation in connection with potential missile hazards (bolts, hardware, lighting fixtures, and the like).

Inasmuch as dust is a known environmental personnel hazard and because of the lack of data on closed underground structures subject to shock from nuclear devices, the Lovelace Foundation for Medical Education and Research conducted a field investigation during Operation Plumbob (Reference 4). The purposes of their study were to document the particle sizes of preshot and postshot dust and to differentiate, if possible, the sources of the postshot dust, e.g., whether particles arose from existing dirt on the floor of shelters or actually spalled from the floor or bulkheads as a result of the detonation. Two types of dust collectors were installed in Structure 3.3c (Appendix B).

2.3.4 Radiation Data Requirements. The radiation-shielding measurements were provided by the Chemical Warfare Laboratory (CWL) (Reference 5) and consisted of gamma film packets (all three structures), chemical neutron dosimeters (all three structures), and neutron threshold devices (two in 3.3c, and one in 3.3a).

The locations of the radiation-measuring devices within the structures are indicated in Table

2.6, and details of the measuring devices are furnished in Appendix C. The neutron-threshold devices, attached to a $\frac{3}{8}$ -inch steel cable, rested in aluminum pipe sections inside the structures. The cable passed from the aluminum section through the 8-inch steel pipe extending from the end of the structure, making a 45-degree turn away from ground zero and a second 45-degree turn toward the surface to approximately 1 foot below the ground level. The $\frac{3}{8}$ -inch cable terminated in a cap covering the end of the steel pipe. To the opposite end of the cap was attached a $\frac{3}{4}$ -inch steel cable which in turn was attached to the Project 2.4 master cable. The recovery tube for the neutron-threshold measuring devices was provided to permit extraction, at approximately H+45 minutes.

The recovery tube is shown in Figure 2.26, and the flexible hose used to prevent shearing of the pipe at the bulkhead of the structure is shown in Figure 2.27. Additional details are included in Appendix A.

In order to completely define the shielding material, an elemental analysis of the soil used for backfill has been included in Appendix A.

2.4 RESULTS

2.4.1 Structural Measurements. The more significant structural measurements are tabulated in Table 2.4. The peak-overpressure values tabulated were arrived at by considering the values indicated by self-recording gages located at each Project 3.3 structure, and the values recorded by other Plumbbob projects at the same range. A further discussion of this is given in Appendix B.

The acceleration results given in Table 2.4 were obtained using electronic accelerometers of 0-to-100 g range. An apparently good electronic record with no apparent acceleration value was obtained for all gages. It may be concluded that the acceleration of the floor slab was less than 3 g in all cases. Self-recording accelerometers placed in the same structures yielded quite different and questionable results. This is further discussed in Appendix B.

Table 2.4 indicates internal pressures of up to 2.7 psi. By use of the approximate formula reported in Reference 6, the total area of all openings to the atmosphere required to permit 2.7-psi internal pressure buildup has been calculated to be about 1.5 ft². There were no known significant openings in the structure at the time of test; therefore, it is considered doubtful that internal pressures as high as 2.7 psi actually existed. The cause of the suspected error is not known.

The dynamic pressure values indicated in Table 2.4 are based on data recorded by Project 1.1 and reported in Reference 7. The measurements were made at a height of 3 feet above ground surface and at the same range from ground zero but not in the immediate vicinity of the Project 3.3 structures.

The average footing displacements given in Table 2.4 are the average of the displacements of the blast-side and leeward-side footings relative to the floor slab. The measurements were taken on D-11 days and D+8 days. Other preshot and postshot survey measurements are given in Table 2.5. Included are measurements taken at various stages of the backfilling process.

The arch-deflection data given in Table 2.4 has been taken from scratch-gage records. Full-scale scratch-gage traces are given in Figures 2.28 through 2.32.

The scratch plates, on which the deflection traces were scribed, were attached to a supporting wood framework solidly attached to the floor slab. The scribing assemblies were attached either to the corrugated arch plating or to the arch ribs at either the crown or a 45-degree point on the arch. Thus, if the errors due to slight rotation and deflection of the scribing assembly and the scratch plate support are not taken into account, the recorded trace indicates the deflection of a point on a structure relative to the floor slab. The absolute motion of the floor slab was not measured, but, based on the acceleration record, it is reasonable to assume that it was small compared to the arch displacement. If the floor slab movement were zero, then the approximate displacement of the point on the arch would be indicated by the scratch trace.

To facilitate further interpretation of the scratch-gage traces, several construction lines

are shown in Figures 2.28 through 2.32. A horizontal and a vertical line are drawn through the initial point. Another horizontal line is drawn a distance below the initial scribe point equal to the correction for residual footing displacement. The heavy dashed line indicates approximately the residual deflection of the point on the arch due only to arch flexure, arch compression, and arch-joint slippage.

Figures 2.33 through 2.52 present an evaluation of the three structures before and after Shot Priscilla. Miscellaneous architectural, mechanical, and electrical details of Structure 3.3c are shown in Figures 2.53 through 2.60.

Only in Structure 3.3a was cracking of the floor evident. A sketch of the crack pattern is shown in Figure 2.38.

In all structures, there was a tendency for the circumferential length of the structure to reduce because of slipping of corrugated plates at the horizontal seams. In no case, however, was a sheared bolt observed. Structure 3.3a experienced the greatest amount: approximately $\frac{1}{8}$ - to $\frac{3}{8}$ -inch movement at each seam (particularly near the springing line). The slipping of joints in Structures 3.3b and 3.3c was approximately 0 to $\frac{1}{8}$ inch.

Minor physical damage occurred to interior partitions, airlocks, and doors by slight racking; however, all interior doors were opened without forcing on initial postshot entry. No noticeable physical damage occurred to the plumbing and electrical systems in Structure 3.3c. The lights in Structure 3.3c were operated postshot, using power from one of the pit-enclosed generators, without any repairs to the system.

The end walls in all three structures were in excellent condition postshot. Entrances and hatch arrangements suffered no significant damage except for a slight buckling of the ladder uprights, which were compressed by the entrance trunk as it deformed slightly.

2.4.2 Environmental Observations. A small amount of dust accumulated on the trays and microscopic slides placed in Structure 3.3c. The data is contained in Reference 4.

Those structural measurements that pertain to environmental hazards—acceleration and internal pressure—are presented in Section 2.4.1. Their significance is discussed in Section 2.5.2.

2.4.3 Radiation Measurements. For this project, thermal radiation was not of significance. The residual nuclear radiation was very small compared to the initial nuclear radiation; consequently, the radiation of interest consisted of prompt gamma and neutron radiation. Results are presented in detail in Appendix C. The gamma and neutron doses are summarized in Table 2.6. Free-field neutron-flux data is included in Reference 8.

2.5 DISCUSSION

All scratch gages, external- and internal-pressure gages, and electronic and self-recording accelerometers functioned; however, the reliability of the internal-pressure records and the self-recording accelerometer records is questionable, as discussed in Section 2.4.1 and Appendix B. All neutron-threshold devices were recovered; a few gamma film records were lost in processing, but sufficient data for test purposes was obtained from similar positions in other structures.

2.5.1 Structural Adequacy of Arches. The structural measurements have been presented in Section 2.4. The criterion for structural adequacy in this case is that the structure maintain its general form and stability; that is, that the structure does not collapse, and that deflections are not great enough to preclude use of the structure as a protective shelter. None of the arches collapsed, and deflections were not great enough to interfere significantly with the use of the structures as a shelter. Thus, the test results indicate the structural suitability of the arch structures for use as personnel shelters, if used under conditions identical to those of this test.

The structures tested had a certain inherent strength due to their form and material charac-

teristics. But a significant part of their strength was due to the passive resistance of the soil, developed by deformation of the flexible arch into the soil backfill.

The relatively large average residual footing displacements ($1\frac{1}{2}$ and $2\frac{7}{16}$ inches) indicates a general downward movement of the arch. It is likely that this movement caused a reduction in the peak soil pressure acting on the arch.

The residual footing displacements and the scratch-gage arch deflection records indicate an asymmetrical blast loading. Three things may have contributed to this: (1) the greater blast overpressure acting on the blast side of the structure, (2) the directional nature of the air-induced earth-stress wave, and (3) the reflected pressure and dynamic pressure acting on the sloping blast side of the covering earth berm. The reflected-pressure and dynamic-pressure effects would likely be reduced by streamlining the earth berm. The same amount of cover material could be placed with a flat 14:1 slope extending out from a crest over the arch crown.

If present knowledge will permit, it is very desirable to use these test results as a basis for more general conclusions regarding the structural suitability of these arches under various soil and loading conditions. To do this, it is necessary to have an understanding of the reaction of the various soils to air-blast loading, the reaction of the structure to the resultant soil loading, and the interaction of the structure response and the soil reaction. The remaining paragraphs of this section discuss this in more detail.

An air-blast load induces a ground shock wave which is propagated through the soil to the structure. This wave interacts with the buried structure, causing the structure to deform. The deformation has a major effect on the contact pressure at the soil-structure interface.

In this test, the free-field overpressures were 60 and 100 psi, and the durations were 361 and 333 msec. But the earth pressures acting at the structure-soil interface were not measured and are not known.

There was probably some attenuation of earth stress as a function of depth, due to the non-elastic nature of the soil and due to the finite velocity and duration of the soil-stress wave. Reference 9 states, "It is known that the dynamic stress-strain curve in earth presents a considerable hysteresis loop, representing a dissipation of energy. This loss probably results largely in the eating away of the shock front, increasing the rise time with increasing depth." Reference 10 states, "In the real case, the finite velocity and duration of the blast wave cause an attenuation of peak stress with depth. This attenuation is obviously a function of duration and should be less with longer durations, but the nature and magnitude of this function are not evident from presently available data. The peaked form of the input also permits reflections from layers of different acoustic impedance to affect the shape and magnitude of the stress wave."

The results of previous field tests indicate that, for blasts of relatively short duration over silty Frenchman Flat soil, there is some attenuation of free-field peak acceleration with increases in soil depth (References 9 and 11). For the same conditions, other investigators have observed an attenuation with depth of pressure acting on a buried stress gage or structure (References 12 through 15). The amount of reduction of pressure depends on the flexibility of the structure (References 13 and 15).

Free-field atomic test data does not agree as to the rate of attenuation of pressure with depth, particularly in the first few feet. Measurements made during Operation Upshot-Knothole (Reference 12), using Carlson-Wiancko earth stress gages at depths of 1, 5, and 15 feet, suggest an exponential or an inverse-power attenuation of vertical earth stress with depth. Some of the gages at depths of 1 and 5 feet indicated an apparent earth stress appreciably greater than the air overpressure at the ground surface. But, according to Reference 12, the near-surface data was erratic and less dependable than the data from the gages at the 15-foot level. In contrast, measurements made during Operation Plumbbob by Project 1.7 (Reference 15), using a calibrated 2-foot-diameter diaphragm as a gage, suggest that the rate of stress attenuation is greatest in the first few feet below ground surface.

Under other conditions at Eniwetok Proving Ground (EPG) the observed results were somewhat different. The two EPG detonations were at the ground surface; one produced a relatively long duration blast, the other a relatively short duration blast. The soil at EPG is predominantly coral sand with the water table only a few feet below ground surface.

Free-field data taken at EPG indicated greater attenuation with depth of local air-induced acceleration than at NTS (Reference 10). The same investigators observed that air-induced ground shock waves were refracted through the earth, from remote locations nearer ground zero, to contribute significantly to earth-acceleration readings. Beyond a certain range, the earth-transmitted wave front outran the air-blast wave, thus masking local air-induced effects.

Preliminary data obtained by another project prompted the following conclusions quoted from Reference 16: "The data suggests that there exists a considerable effect of structure flexibility on the pressures on structures buried both above and below the water table in this soil;" and "The data also suggests that a large-magnitude surface burst can produce very-large horizontal water-transmitted pressures, which will be greater than the air-induced pressures below the water table."

During Operation Hardtack, Project 3.2 tested two earth-covered, 25-foot-span, corrugated-steel, 180-degree arch structures, one subjected to 90-psi overpressure from a kiloton-range detonation and the other subjected to 78 psi from a megaton-range detonation. Reference 17 reports "Since the two arch shells were identical and the confining earthworks were almost identical, the fact that Structure 3.2b suffered complete collapse at 78 psi (long-duration loading), and Structure 3.2a sustained extensive localized damage without complete collapse at 90 psi (short-duration loading) is significant." These two Hardtack structures were similar to Plumbbob Structure 3.3b (which withstood 60-psi overpressure), but the soil type and soil-cover configurations were quite different. Therefore, a direct comparison of the Hardtack 3.2 and Plumbbob 3.3 results is not warranted.

With the exception of References 12 and 13, the test reports cited above are preliminary reports subject to further analysis, development, and possible revision. These reports point out some of the many variables that may affect the loading and response of a buried structure, for certain limited test conditions. They also suggest some of the hazards of extrapolating test data to predict results under other conditions.

A quantitative understanding of the effect of all significant variables is required before the data of this test can be used to predict accurately the results for other conditions.

2.5.2 Suitability of Internal Environment. Peak vertical acceleration of the floor slab of each structure was < 3 g. Had the floor slab not been isolated from the metal arch, the accelerations would likely have been greater.

Regarding acceleration criteria, Reference 16 states that, for humans, the limit of acceleration depends to a great extent upon the manner in which the forces arising act on the body. This reference reports studies made to determine the tolerable limits of acceleration on a human strapped into an aircraft-type seat. The investigator reports that a person so supported can tolerate 20 g's deceleration of a forward moving seat for a duration of a few hundred milliseconds without injury. The same studies report that a man so supported can withstand an upward acceleration of the seat up to about 20 g's for 100 msec without injury. But it cannot be assumed that shelter occupants will be so well supported. Nevertheless, if accelerations of < 3 g are thought to be excessive for certain shelter uses, their effect could be reduced by installing the necessary shock isolation mechanisms inside the structure.

Shelter displacement may, in some cases, be more important than shelter acceleration, depending on the design of the structure, soil conditions, loading, and perhaps other factors. A certain combination of conditions could result in a downward movement of the shelter floor, leaving unattached persons or objects falling freely above until they are met by the floor as it rebounds upward. Such was very likely not the case in this test. Even if other conditions had been compatible with such a response, the isolation of the floor slab from the arch foundation would likely have prevented it.

Peak-pressure gages indicated overpressures of up to 2.7 psi inside the structures, but the reliability of these measurements is questionable, as discussed in Section 2.4.1. Regarding pressure criteria, Reference 17 reports that the atomic explosions in Japan during World War II resulted in "no cases of direct damage to internal organs by the blast among survivors although

there were some ruptured eardrums." The reference later states, "The air-blast overpressure required to cause rupture of eardrums appears to be highly dependent upon circumstances. Several observations indicate that the minimum overpressure is in the range from 10 to 15 pounds per square inch, but both lower and higher values have been reported." Even if internal overpressures were as high as 2.7 psi in one of the test structures, it is very unlikely that such a condition would be hazardous to personnel.

Under the test conditions, it is unlikely that shelter occupants would have suffered any harm due to dust inside the shelter.

2.5.3 Nuclear Radiation Shielding Effectiveness. Because the maximum nuclear radiation dose that may be measured with a film pack is 70,000 r, no experimental method was available for direct measurement of the very high dose received at the free-field stations close to ground zero. The free-field gamma measurements listed in Table C.1 were obtained by extrapolation from data obtained for Project 2.4. It is recognized that the validity of the linear extrapolation to close ranges is open to question but no other procedure presented itself. Free-field neutron dosimeter readings are also listed in Table C.1.

All Project 3.3 structures gave adequate shielding for the conditions under which they were tested.

The radiation levels in the entrances were from 25 to 40 times as great as the radiation levels in the personnel areas. It is assumed however, that personnel would be in those areas and would not occupy the entrance at the time of detonation. The entrance way was only designed to allow for the entrance and exit of test personnel and equipment. Such an entranceway is not recommended for an operational shelter. A significant gamma dose was received at the bottom of the 24-inch ventilation duct (Structure 3.3c); however, a reverse bend in the pipe and sandbag baffle reduced this level to a tolerable value in the equipment room of that structure.

In the personnel areas, the maximum dose was recorded in Structure 3.3a. The gamma dose measured at Station F by chemical dosimeter was 36 r and by film badge was 7.4 r (Tables C.2 and C.3). The neutron dose for this location was lost in processing. At Station E the neutron dose by chemical dosimeter was 44 rep, and by foil method it was less than 25 rep. The gamma dose by chemical dosimeter at Station E was 10 r. This would yield a combined dose of 54 rem, assuming that the neutron RBE (relative biological effectiveness) was close to one. According to Reference 18, the probability is that this dose would produce no significant medical effects on human beings. This reference indicates that, for doses less than 75 r, no immediate sickness or late effects will result.

For the conditions of this test, if it is determined that the dose within this type of structure should be less than the atomic industry standard of 5 r per year, the amount of earth cover would have to be increased from 5 feet to 7 feet.

2.6 CONCLUSIONS

Based on the field test results, it is concluded that both types of corrugated-steel arch structures—ribbed and nonribbed—will provide adequate Class II (50-psi overpressure and comparable radiations) protection for the same conditions (loading, soil, dimensions, and so forth) as those of this test.

In addition, for the particular conditions of this test and within the accuracy of the overpressure measurements, it was observed that:

1. The steel arch structure without arch ribs withstood a peak overpressure of 60 psi.
2. The steel arch structure with arch ribs withstood a peak overpressure of 100 psi.
3. All three structures tested provided adequate protection against nuclear radiation.
4. No significant physical damage occurred to the plumbing and electrical fixtures installed in the ribbed arch structure at the 60-psi overpressure range.

Knowledge gained from this test does not justify making more general conclusions.

2.7 RECOMMENDATIONS

If future tests are made on similar structures it is recommended that the structures be instrumented to obtain the following data:

1. Soil pressure versus time at the structure-soil interface at several points on the arch.
2. Soil pressure versus time at points in the soil cover between the top of the earth berm and the structure.
3. The relative motion of the arch, footings, and floor slab with respect to an undisturbed point in the earth as a function of time.
4. The change in shape of the structure as a function of time.
5. Air overpressure versus time inside the structure.
6. Air overpressure versus time on the surface of the earth berm covering the structure.
7. A common zero reference for all time records.

There is a need for further study into the nature of shock propagation through soil. Many questions are as yet unanswered concerning: the attenuation, reflection, and refraction of shock energy; the partition of energy when a shock wave meets an air-soil boundary, a water-soil boundary, an unsaturated soil-saturated soil boundary, or a structure-soil boundary; and similitude. It is recommended that these questions be thoroughly studied, both analytically and experimentally, to obtain a rational solution to the underground structure problem.

TABLE 2.1 SUMMARY OF CORRUGATED-STEEL STRUCTURE TESTS

Operation and Shot	Surface Structure No.	Exposure Condition	Overpressure psi	Dynamic Pressure psi	Damage
Upshot-Knothole, Shot 5	3.15	3-ft earth cover on sides of arch (lakebed silt)	10.8	Not recorded	Elastic response; door projected into structure.
Upshot-Knothole, Shot 10	3.15	3-ft earth cover on sides of arch (lakebed silt)	8.1	Not recorded	Elastic response; no significant damage.
Teappt, Shot 12	3.15	3-ft earth cover on sides of arch (lakebed silt). Crown awash.	13.0	33.0	No significant damage.
Teappt, Shot 12	3.6	3-ft earth cover (granular material). Moderately wide earth berm.	30.0	150.0	Side of arch toward ground zero collapsed; not operational; 50 to 100 percent personnel casualties estimated.

TABLE 2.2 PROPERTIES OF CORRUGATED-STEEL PLATES

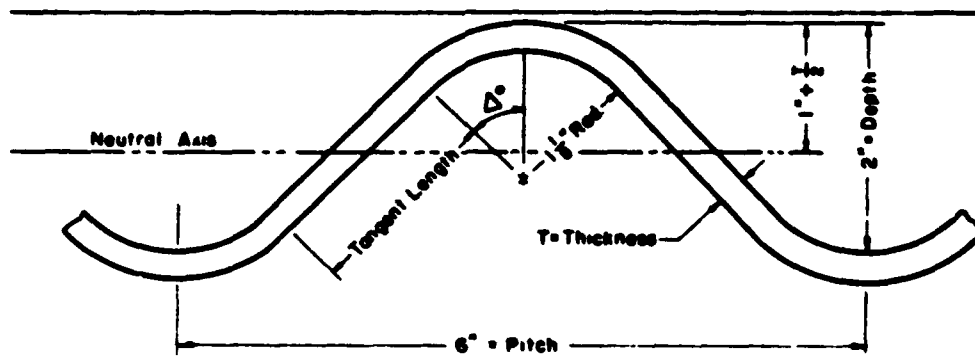

Properties	3 Gage	8 Gage	10 Gage
Thickness T, in	0.2451	0.1644	0.1345
Tangent length, in	1.7377	1.8283	1.8606
Angle Δ , deg	45 deg 47 min	45 deg 00 min	44 deg 44 min
Moment of inertia, in ⁴ *	1.756	1.153	0.937
Area of section, in ² *	3.658	2.449	2.003
Section modulus, in ³ *	1.564	1.066	0.878
Radius of gyration, in	0.693	0.696	0.684

* Per ft of horizontal protection.

TABLE 2.3 STRUCTURAL INSTRUMENTATION

Number	Type	Structure	Position in Structure
4	Deflection gages (scratch)	3.3a	Crown (steel plate) Crown (ribs) Quarter points (ribs) Quarter points (ribs)
4	Deflection gages (scratch)	3.3c	(Same as 3.3a)
3	Deflection gages (scratch)	3.3b	Crown (steel plate) Quarter points (steel plate) Quarter points (steel plate)
3	Self-recording pressure-time gages	3.3a, 3.3b 3.3c	Original earth surface Center of earth berm
3	Peak internal pressure gages	3.3a, 3.3b, 3.3c	Interior
2	Self-recording accelerometer (vertical component)	3.3a, 3.3c	Floor (center)
1	Peak accelerometer (vertical component)	3.3b	Crown (steel plate)
3	Electronic dynamic accelerometer (vertical component)	3.3a, 3.3b, 3.3c	Center of floor.

TABLE 2.4 STRUCTURAL MEASUREMENTS

	Structure		
	3.3a	3.3c	3.3b
Station number	9019.01	9019.02	9019.03
Type of structure	Ribbed	Ribbed	Not ribbed
Nominal depth of earth cover, ft	5	5	5
Peak overpressure at earth surface, psi	100	60	60
Positive duration of pressure pulse, msec	333	—	361
Dynamic pressure, psi *	310	200	200
Peak internal pressure, psi	2.7	0	1.0
Peak vertical acceleration of floor, g	< 3	< 3	< 3
Average displacement of footings at midlength relative to floor slab, in	2 ⁷ / ₁₆	1 ¹ / ₂	1 ¹ / ₂
Maximum deflection of arch rib at crown relative to floor slab, in	4 ¹ / ₈	3 ¹ / ₁₆	—
Residual deflection of arch rib at crown relative to floor slab, in	2	1 ¹³ / ₁₆	—
Maximum deflection of corrugated- steel arch at crown relative to floor slab, in	5 ⁵ / ₁₆	3 ⁵ / ₈	4
Residual deflection of corrugated- steel arch at crown relative to floor slab, in	3 ⁵ / ₁₆	2 ¹ / ₈	2 ⁵ / ₈
Ratio: Maximum deflection of corrugated arch at crown relative to floor span, pct	1.76	1.20	1.33
Ratio: Residual deflection of corrugated arch at crown relative to floor span, pct	1.10	0.71	0.92

* From preliminary composite dynamic pressure curve for height of 3 ft.

TABLE 2.5 SURVEY MEASUREMENTS

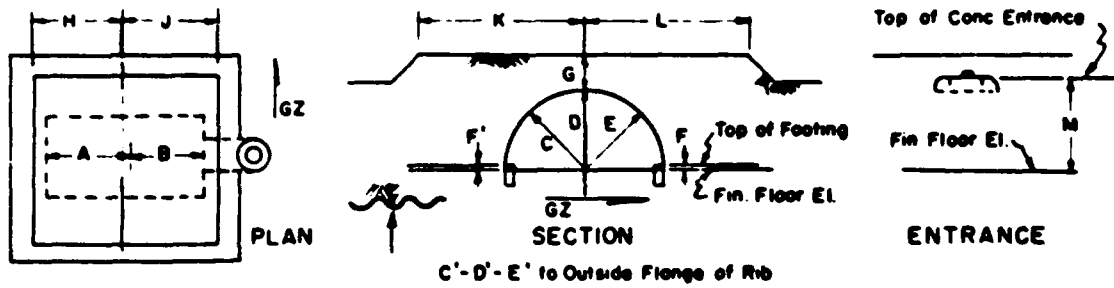

+ = top of footing below finish floor elevation. - = top of footing above finish floor elevation.

Structure	Location	No Fill		6 ft 6 in Fill		Crown Awash		Backfill Complete		11 Days Preshot		8 Days Postshot	
		ft	in	ft	in	ft	in	ft	in	ft	in	ft	in
3.3a	A	26	5 ³ / ₈	26	5 ³ / ₈	26	5 ³ / ₈	26	5 ³ / ₈	26	5 ³ / ₈	26	4
	B	21	5 ³ / ₈	21	5 ³ / ₈	21	5 ³ / ₈	21	5 ¹ / ₄	21	5 ¹ / ₄	21	4 ¹ / ₂
	C	11	10 ³ / ₈	11	10 ³ / ₈	11	10	11	9 ¹ / ₂	11	9 ¹ / ₂	11	8 ¹ / ₂
	C'	11	10 ¹ / ₄	11	10 ¹ / ₄	11	10	11	10	11	10	11	9
	D	11	8 ³ / ₈	11	8	11	9 ¹ / ₂	11	9 ¹ / ₂	11	9 ¹ / ₂	11	5 ³ / ₈
	D'	11	8	11	8 ³ / ₄	11	8 ¹ / ₂	11	8 ³ / ₄	11	8 ³ / ₄	11	5 ³ / ₈
	E	11	11 ¹ / ₄	11	11 ¹ / ₂	11	10 ¹ / ₄	11	10 ³ / ₈	11	10 ³ / ₈	11	6 ³ / ₈
	E'	11	11 ¹ / ₂	11	11 ¹ / ₄	11	11	11	10 ¹ / ₂	11	10 ³ / ₈	11	7 ¹ / ₂
	F	-0	1 ¹ / ₈	-0	1 ¹ / ₈	-0	1 ¹ / ₈	-0	1 ¹ / ₈	-0	1 ¹ / ₈	+0	1 ¹ / ₈
	F'	-0	2	-0	2	-0	2	-0	2	-0	2	-0	1 ¹ / ₈
	G	-	-	-	-	-	-	-	-	5	11 ¹¹ / ₁₆	4	11 ¹ / ₂
	H	-	-	-	-	-	-	-	-	26	4 ¹ / ₄	26	3
	J	-	-	-	-	-	-	-	-	26	4 ¹ / ₂	24	1
K	-	-	-	-	-	-	-	-	25	2 ¹ / ₂	24	8	
L	-	-	-	-	-	-	-	-	24	9 ³ / ₈	23	7	
M	-	-	-	-	-	-	-	-	13	5 ¹¹ / ₁₆	13	4 ¹ / ₄	
3.3b	A	24	5 ¹ / ₂	24	5 ³ / ₈	24	5 ¹ / ₄	24	5 ¹ / ₄	24	5 ¹ / ₄	24	4 ¹ / ₂
	B	23	5 ¹ / ₂	23	5 ³ / ₈	23	5 ³ / ₈	23	5 ³ / ₈	23	5 ³ / ₈	23	5 ³ / ₈
	C	11	10 ³ / ₈	11	9 ³ / ₈	11	8 ³ / ₈	11	8 ¹ / ₄	11	8 ¹ / ₄	11	7 ¹ / ₂
	D	11	8 ³ / ₄	11	10 ¹ / ₂	12	3 ¹ / ₂	12	3 ¹ / ₄	12	1 ¹ / ₂	11	9 ¹ / ₂
	E	11	11 ¹ / ₂	11	10 ¹ / ₄	11	10	11	9 ³ / ₄	11	9 ³ / ₄	11	7 ¹ / ₂
	F	0	0	0	0	0	0	0	0	0	0	+0	1 ¹ / ₂
	F'	0	0	0	0	0	0	0	0	0	0	+0	1 ¹ / ₂
	G	-	-	-	-	-	-	-	-	4	8 ¹ / ₂	4	8 ¹ / ₂
	H	-	-	-	-	-	-	-	-	27	10	27	5
	J	-	-	-	-	-	-	-	-	27	3 ³ / ₄	24	7
	K	-	-	-	-	-	-	-	-	23	7 ³ / ₄	23	9 ¹ / ₂
	L	-	-	-	-	-	-	-	-	26	11	25	3 ¹ / ₂
	M	-	-	-	-	-	-	-	13	7 ¹ / ₄	13	8	13
3.3c	A	21	1 ¹ / ₂	21	3 ¹ / ₈	21	3 ¹ / ₈	20	11 ³ / ₈	20	11 ³ / ₈	21	11 ¹ / ₂
	B	26	10 ³ / ₁₆	26	10 ¹ / ₄	26	10 ¹ / ₄	26	10 ¹ / ₄	26	10 ¹ / ₄	26	10 ¹ / ₄
	C	12	1 ¹ / ₄	11	11 ³ / ₈	11	11 ³ / ₈	11	11 ³ / ₈	11	11 ³ / ₈	11	10 ¹ / ₂
	C'	12	0	11	11 ¹ / ₈	11	11 ³ / ₈	11	11 ³ / ₈	11	11 ³ / ₈	11	11
	D	11	9 ¹ / ₄	11	9 ¹ / ₂	11	9 ³ / ₈	11	9 ³ / ₈	11	9 ³ / ₈	11	7 ¹ / ₂
	D'	11	9 ³ / ₈	11	9 ¹ / ₂	11	9 ³ / ₈	11	9 ³ / ₈	11	9 ³ / ₈	11	7 ¹ / ₂
	E	12	5 ¹ / ₈	12	1 ¹ / ₂	12	3 ¹ / ₈	12	1 ¹ / ₂	12	1 ¹ / ₂	11	9 ³ / ₈
	E'	11	11 ¹ / ₄	11	11 ³ / ₄	11	11 ³ / ₄	11	11 ³ / ₄	11	11 ³ / ₄	11	10 ³ / ₄
	F	-0	2	-0	2	-0	2	-0	2	-0	2	0	0
	F'	-0	2	-0	2	-0	2	-0	2	-0	2	-0	1
	G	-	-	-	-	-	-	-	-	4	11 ¹¹ / ₁₆	5	1 ¹ / ₂
	H	-	-	-	-	-	-	-	-	28	4 ¹ / ₂	28	5
	J	-	-	-	-	-	-	-	-	27	4 ¹ / ₂	25	6 ¹ / ₂
K	-	-	-	-	-	-	-	-	24	7 ¹ / ₄	24	4 ¹ / ₂	
L	-	-	-	-	-	-	-	-	25	7 ¹ / ₄	24	1	
M	-	-	-	-	-	-	-	-	13	8 ³ / ₁₆	13	9 ¹ / ₁₆	

TABLE 2.6 RADIATION MEASUREMENTS

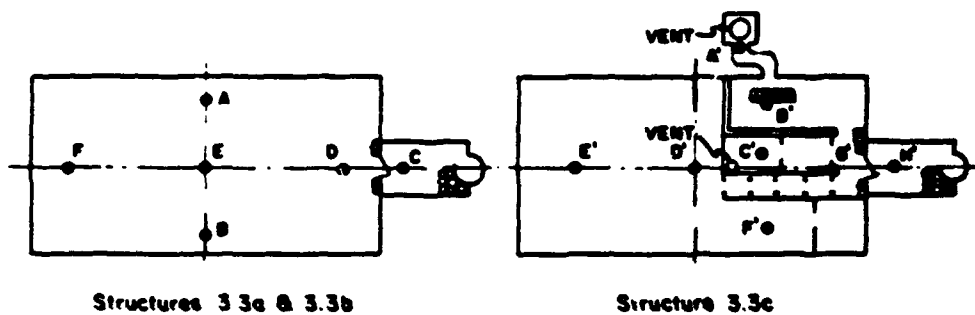

Structure	Location	Gamma Dose, r		Neutron Dose, rep	
		Foil Method	Chemical Dosimeter	Foil Method	Chemical Dosimeter
3.3a	A	•	<5	†	<10
	B	•	<5	†	<10
	C	•	64	†	64
	D	16.2	24	†	14
	E	•	10	<25	44
	F	7.4	36	†	•
3.3b	A	1.2	<5	†	<10
	B	2.3	<5	†	<10
	C	84	84	†	<10
3.3c	A'	90	88	†	140
	B'	1.05	<5	†	<10
	C'	5.0	<5	†	<10
	D'	4.5	<5	<25	<10
	E'	4.0	<5	<25	<10
	F'	3.0	<5	†	<10
	G'	15.0	27.5	†	30
	H'	97	117	†	<10

• Lost in processing. † Not instrumented.

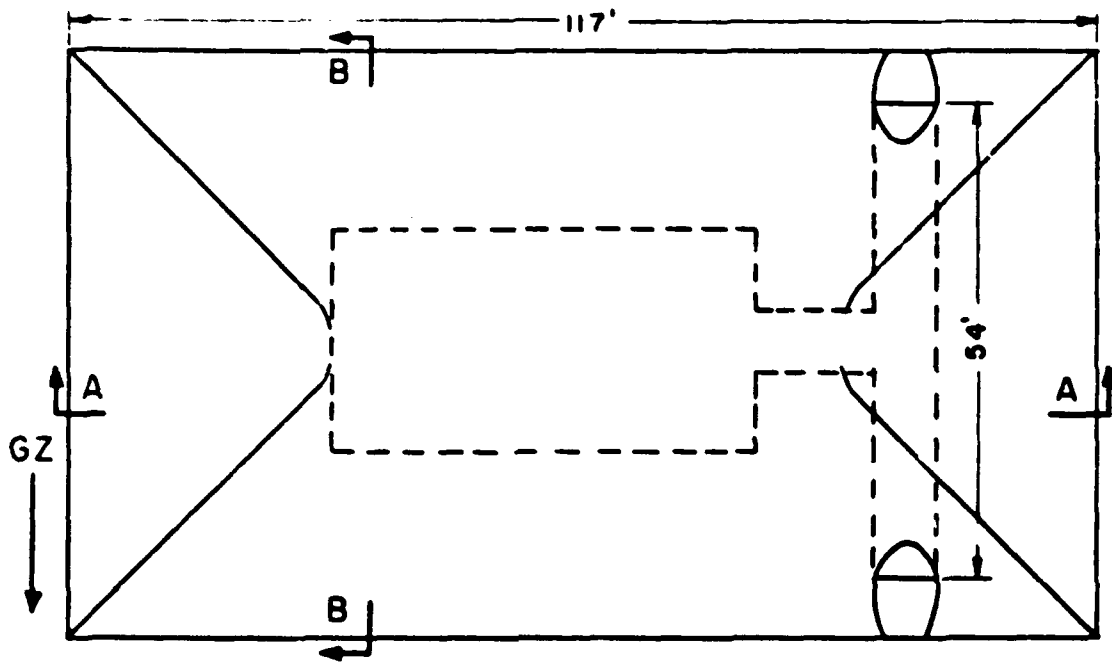

PLAN

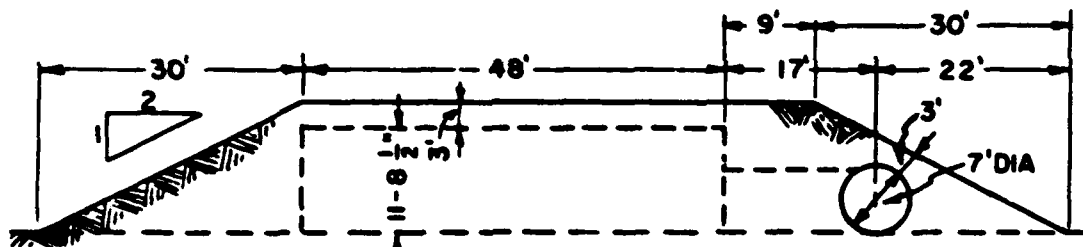

SECTION "A-A"

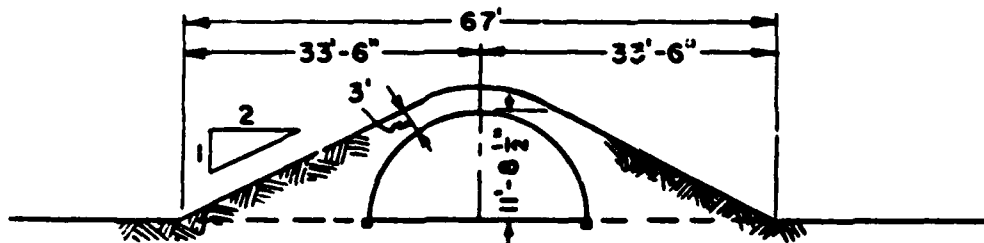

SECTION "B-B"

Figure 2.1 Earth configuration for Structure 3.15, Operation Upshot-Knothole.

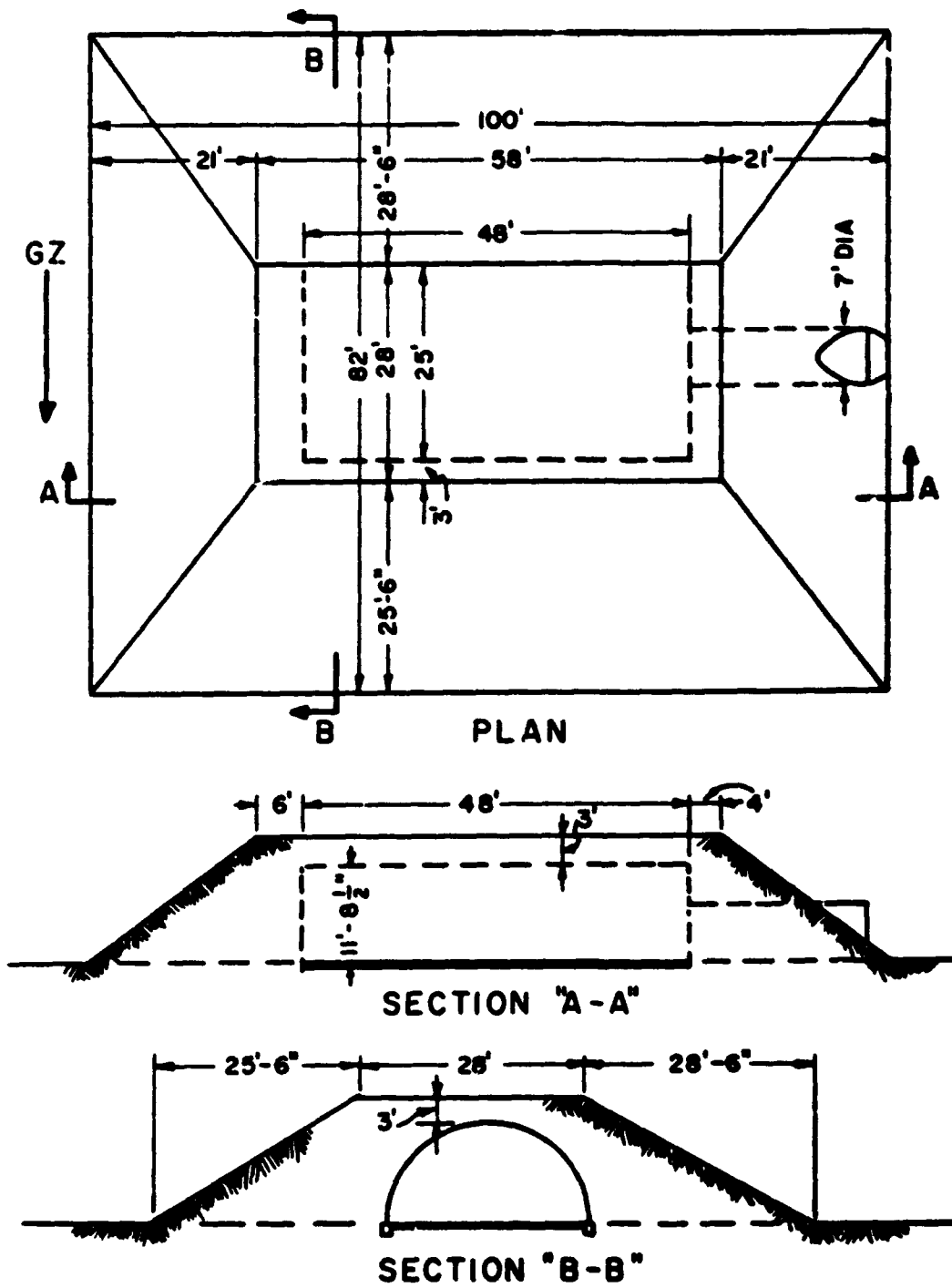
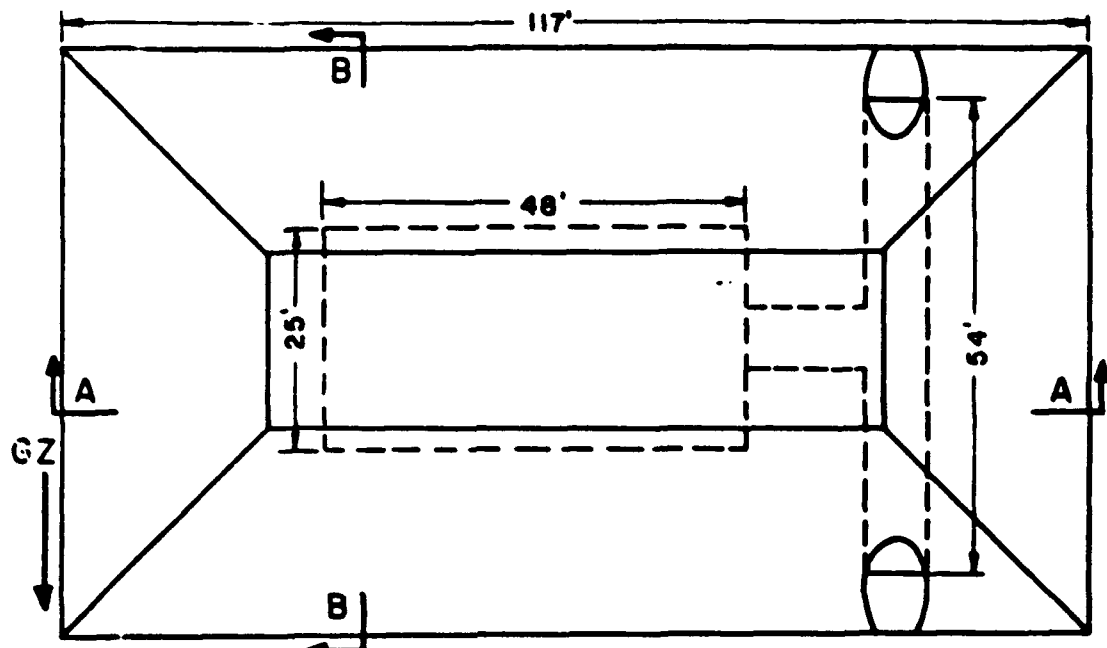
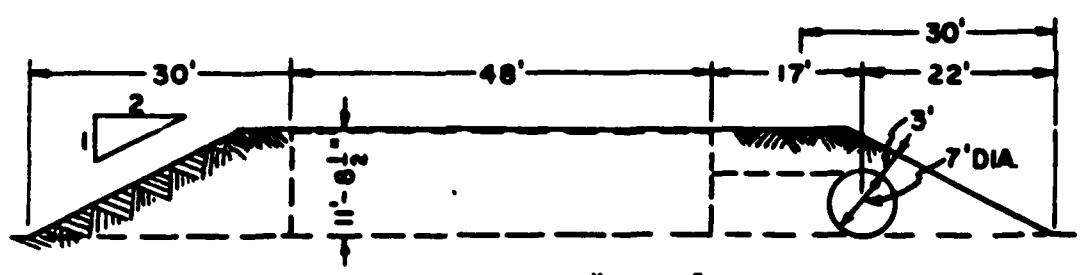

Figure 2.2 Earth configuration for Structure 3.6, Operation Teapot.



PLAN



SECTION "A - A"

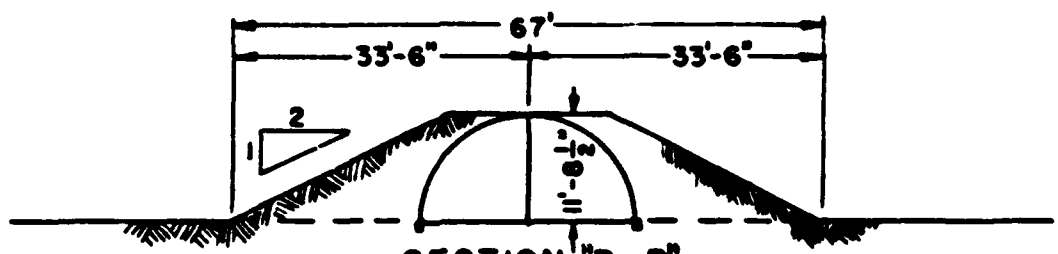

SECTION "B - B"

Figure 2.3 Modified earth configuration for Structure 3.15, Operation Teapot.

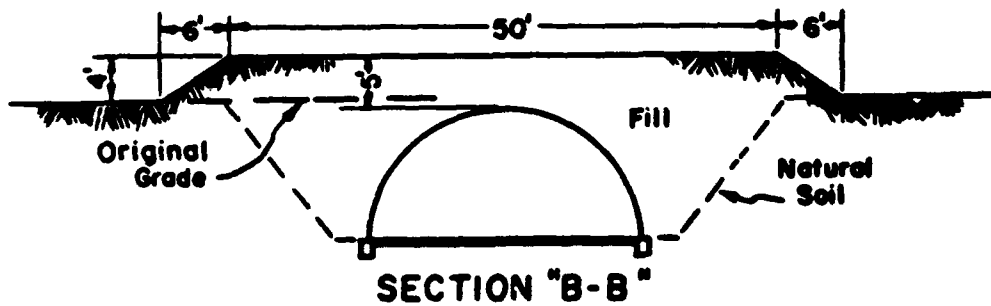
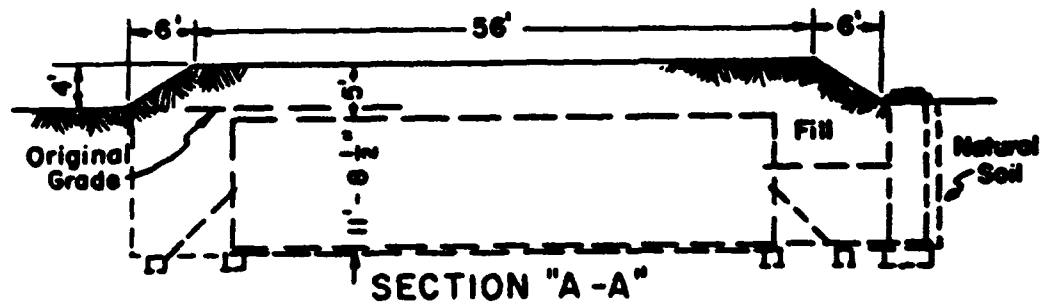
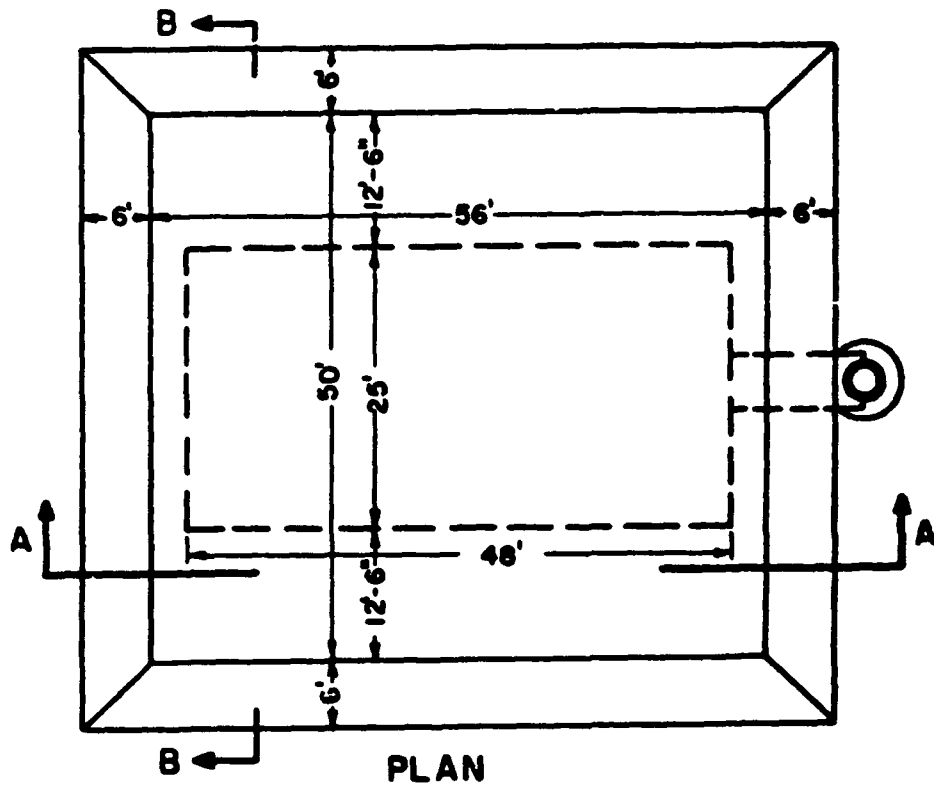

Figure 2.4 Earth configuration for Structure 3.3, Operation Plumbbob.

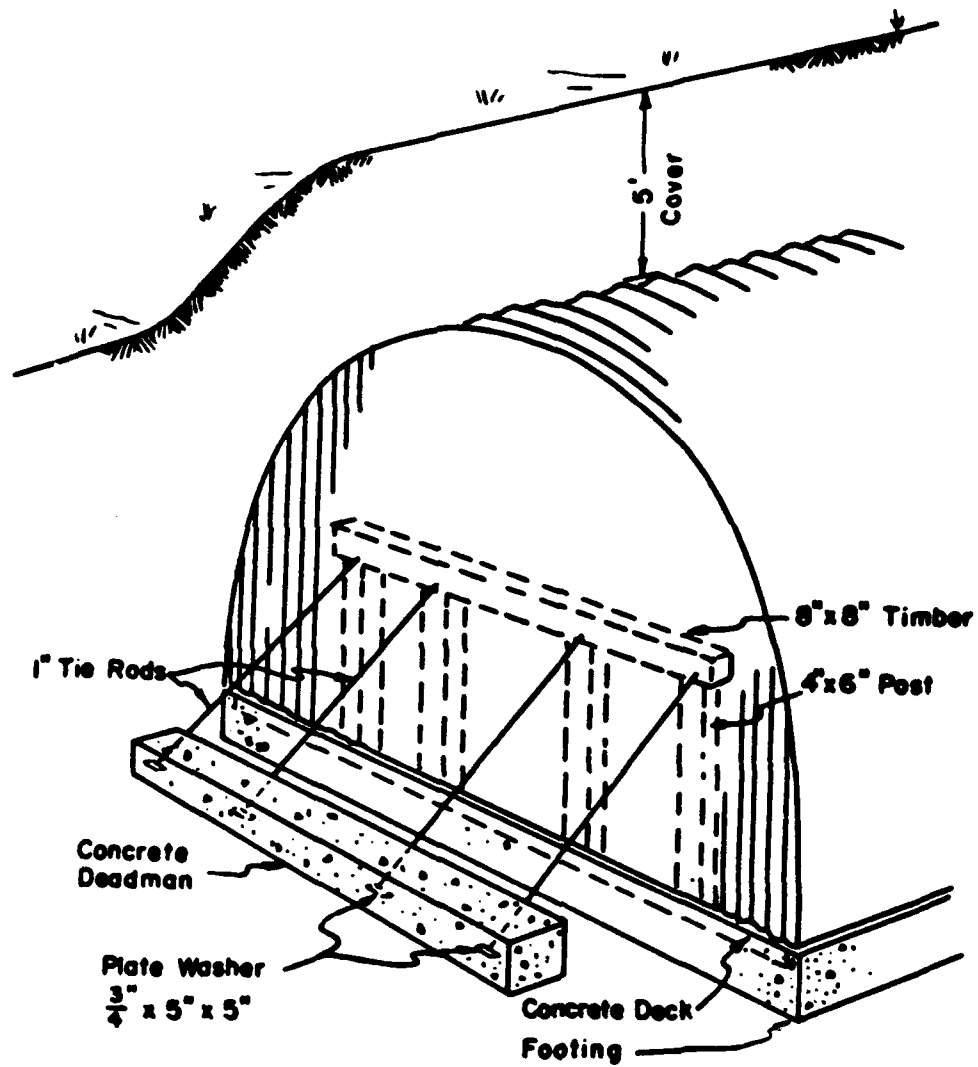

Figure 2.5 End bulkhead.

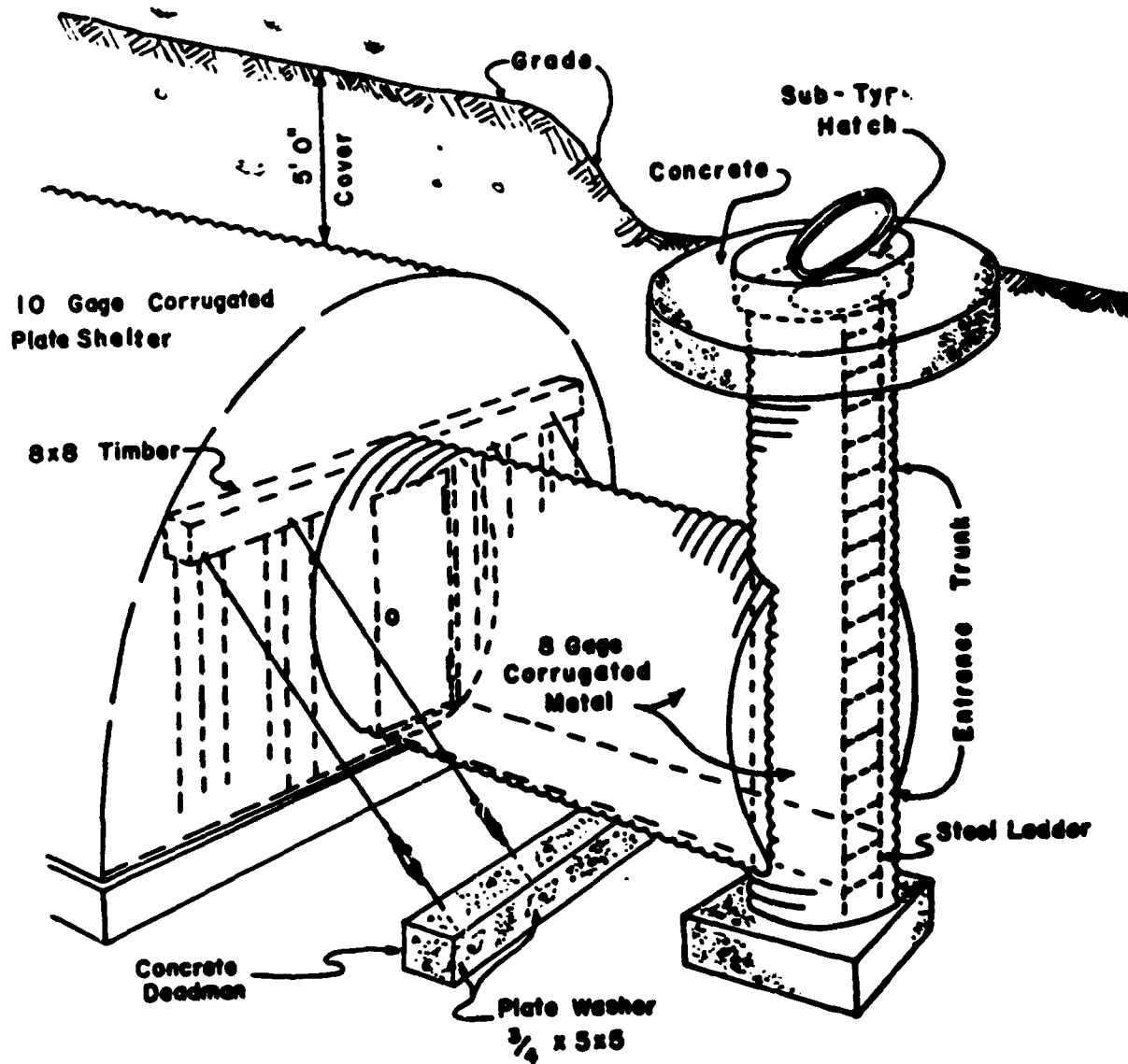

Figure 2.6 Shelter entrance.

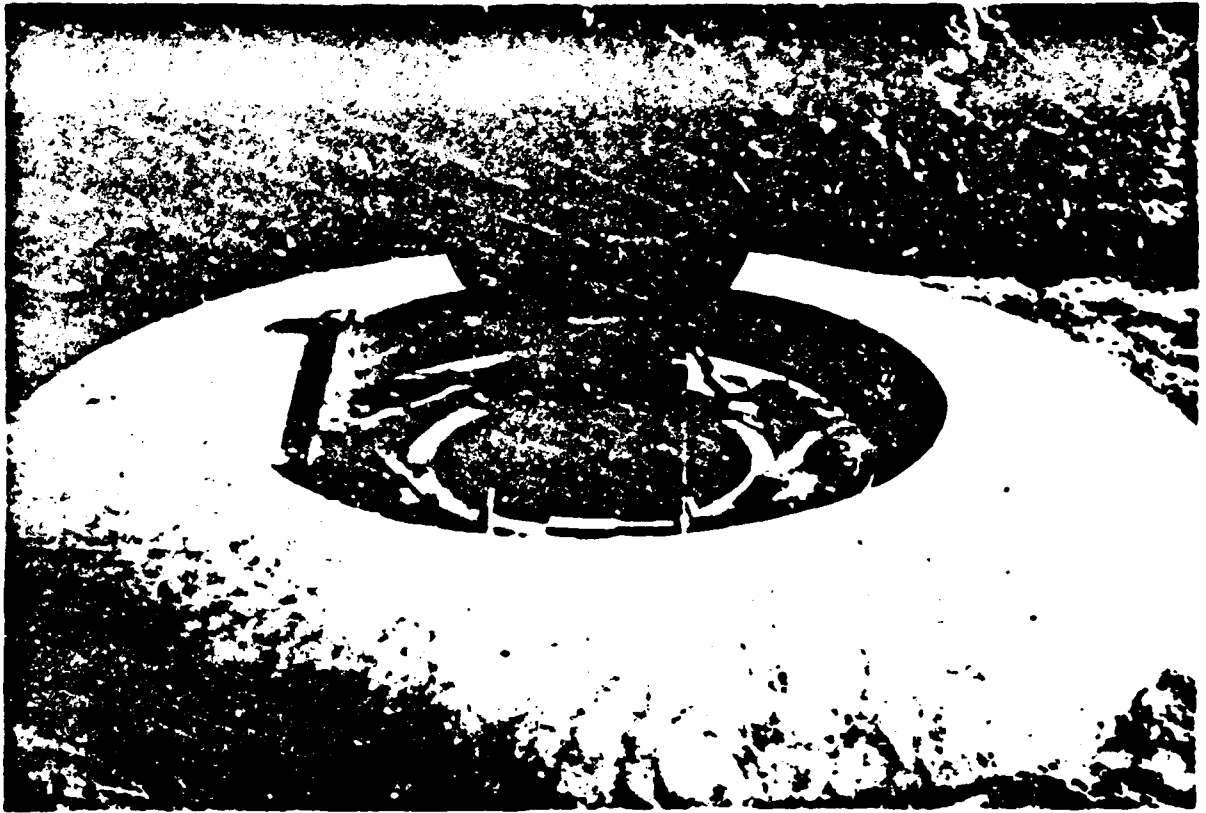

Figure 2.7 Submarine-type hatch cover (open).

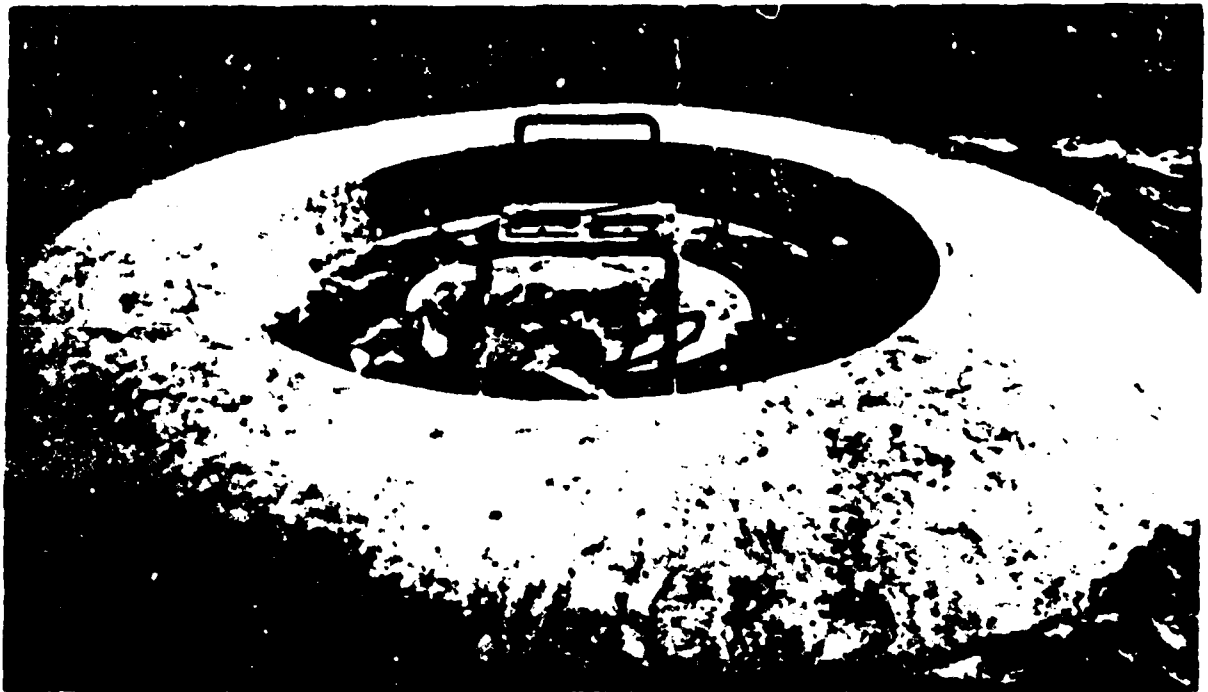

Figure 2.8 Submarine-type hatch cover (closed).

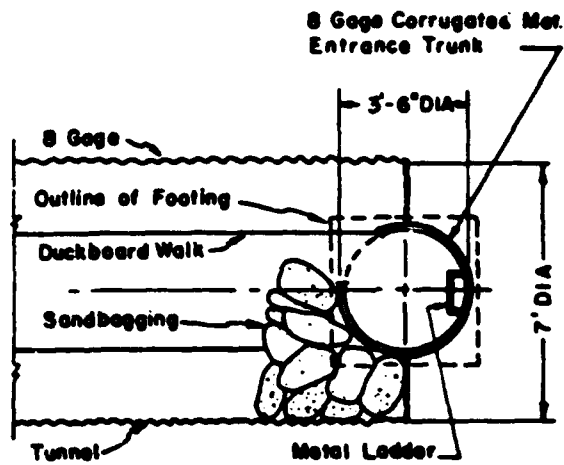

Figure 2.9 Plan of entrance trunk at tunnel.

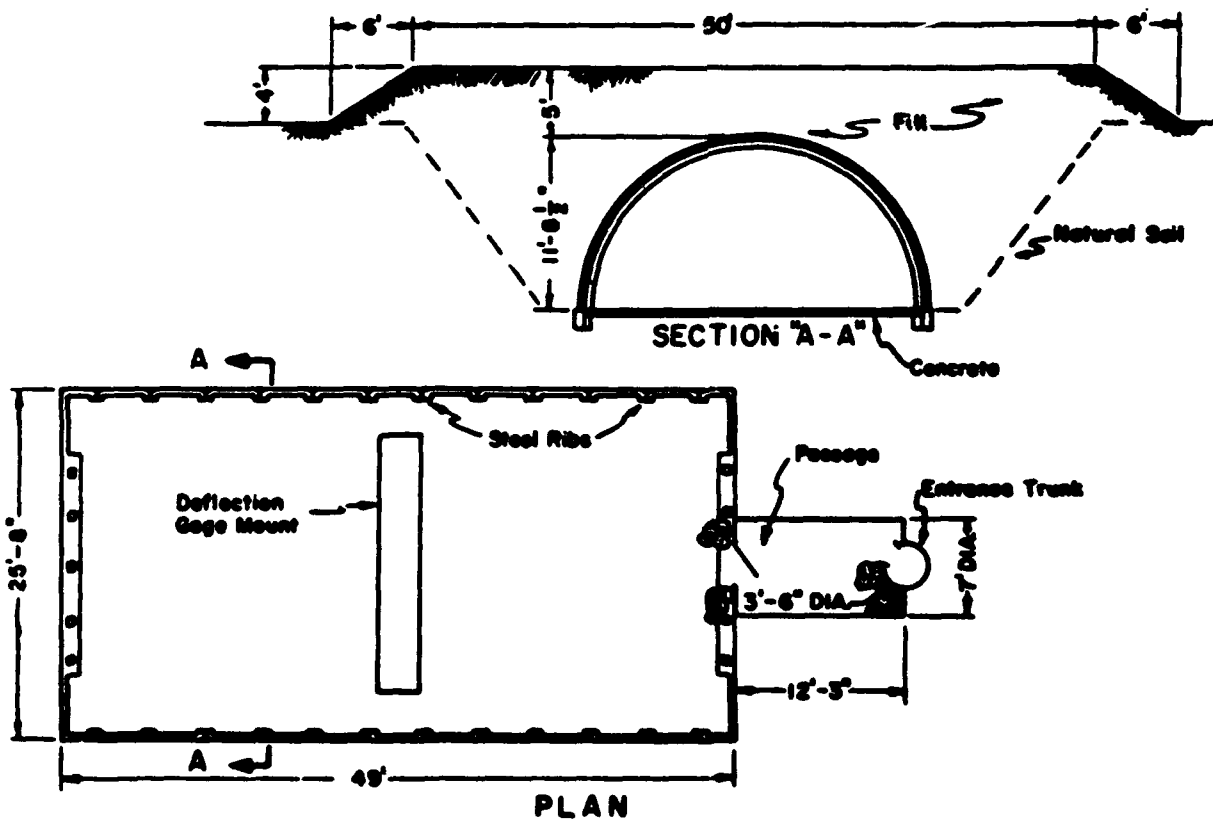
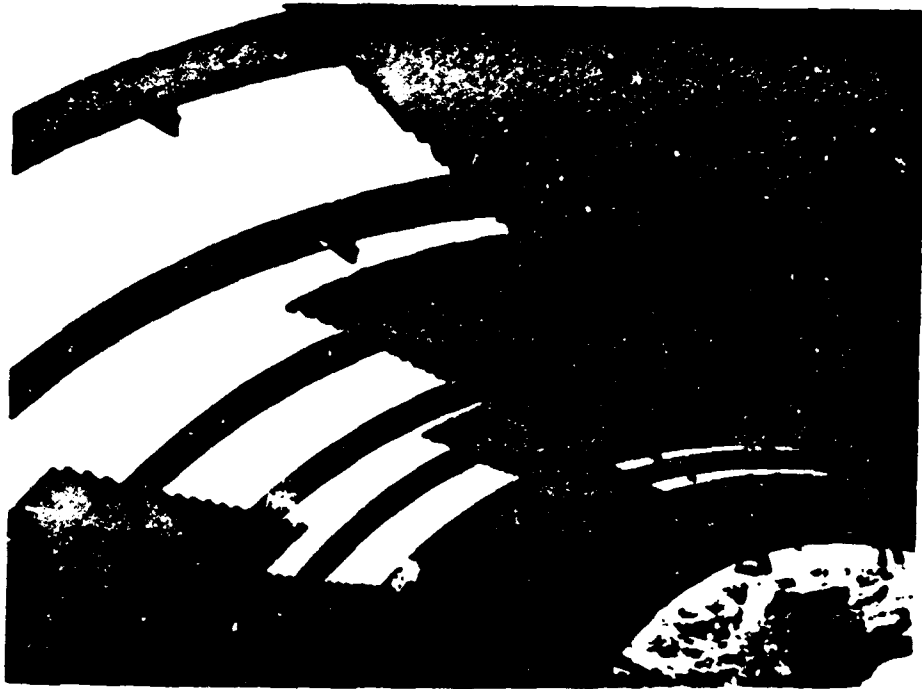

Figure 2.10 Plan and section of Structure 3.3a.



**Figure 2.11 Erection of corrugated plate
on steel arch rib, Structure 3.3a.**

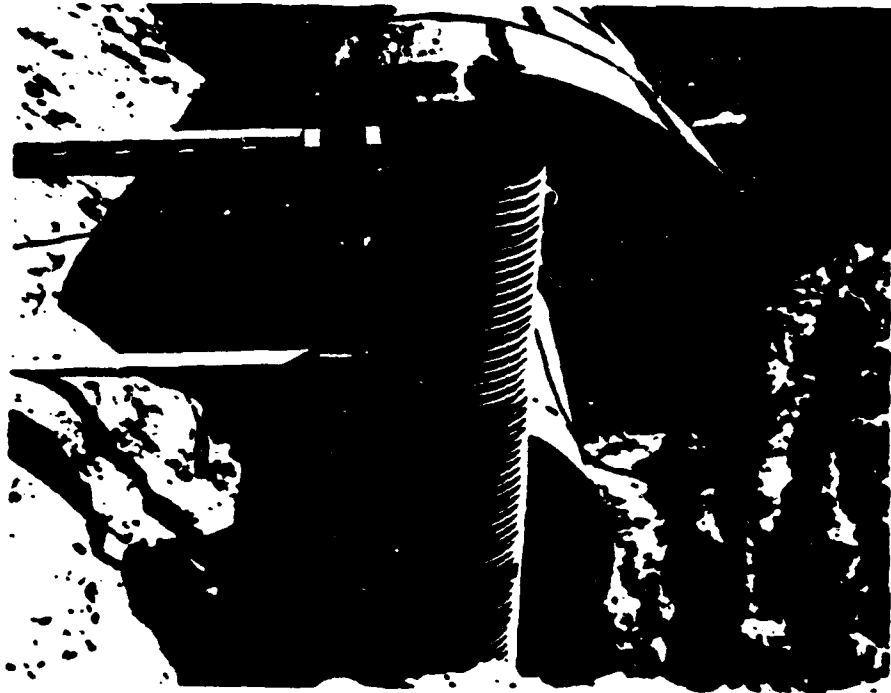

Figure 2.12 Front view prior to backfilling, Structure 3.3a.

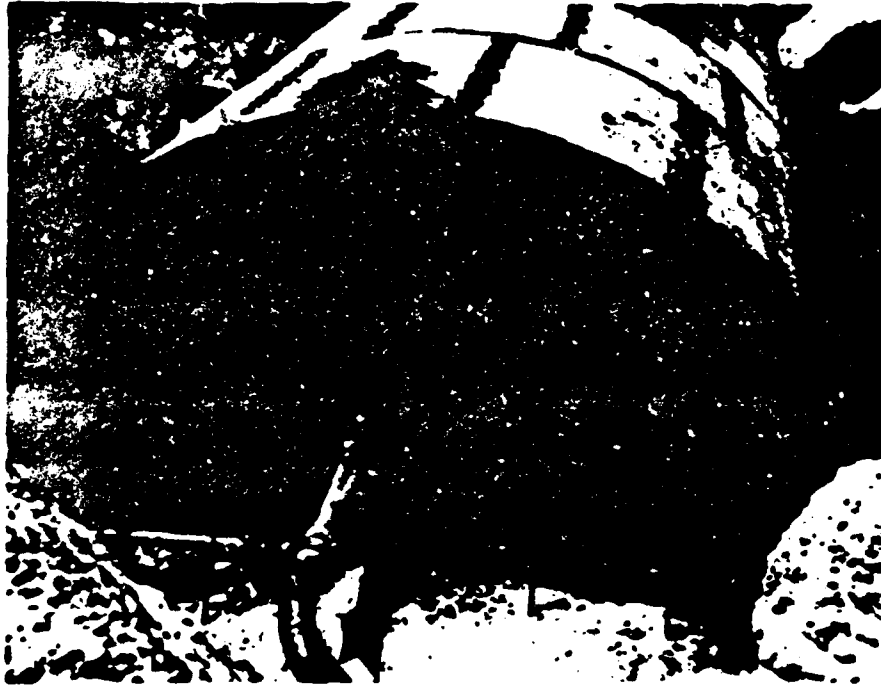

Figure 2.13 Rear view prior to backfilling, Structure 3.3a.

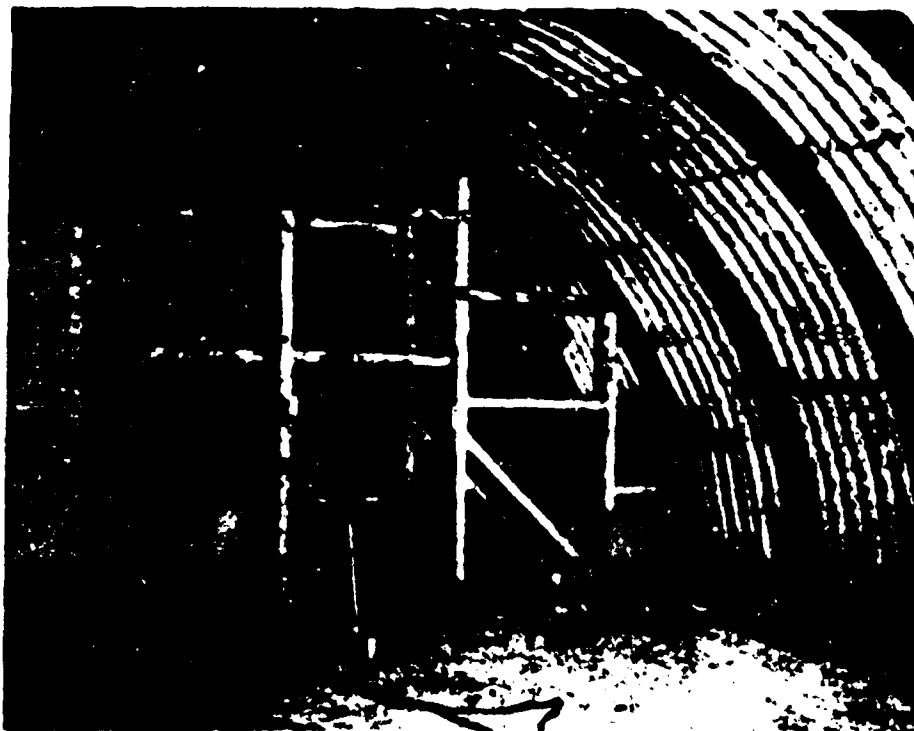

Figure 2.14 Interior view, Structure 3.3a.

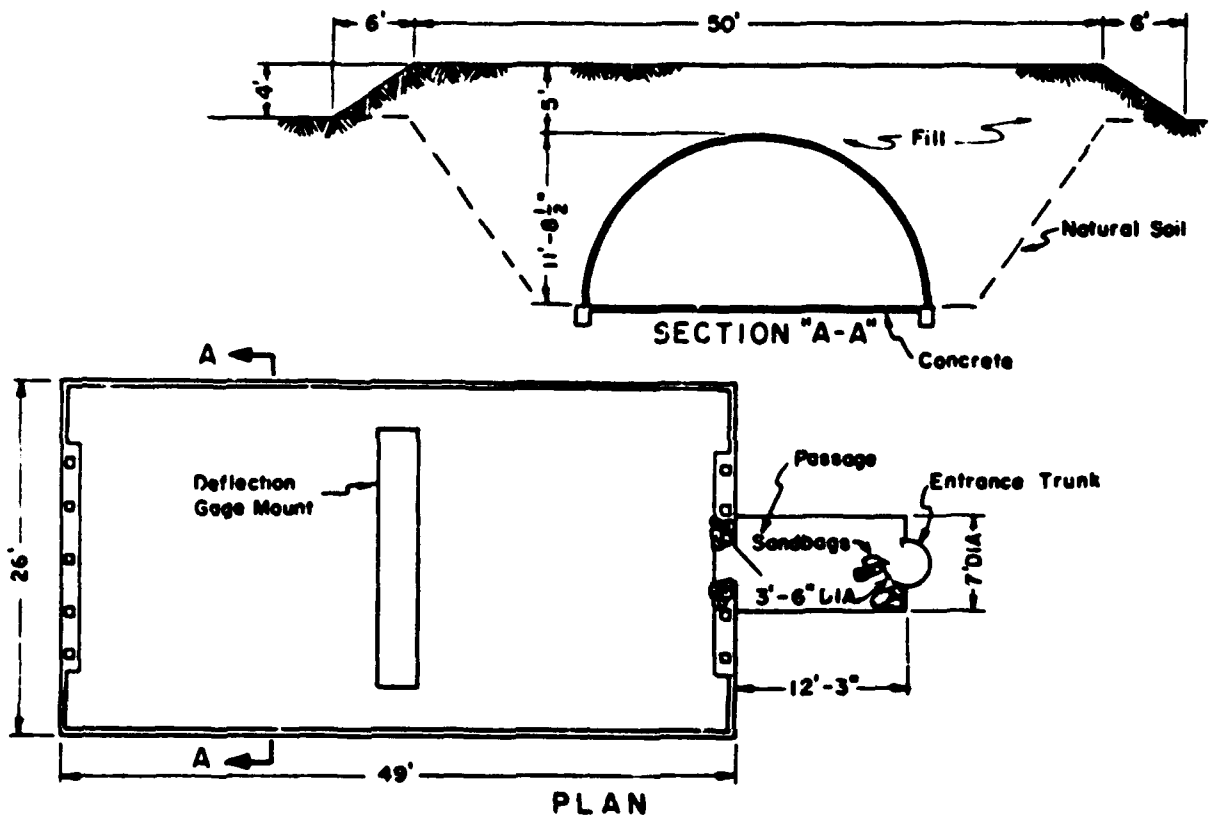

Figure 2.15 Plan and section of Structure 3.3b.



Figure 2.16 Top view prior to backfilling, Structure 3.3b.



Figure 2.17 Access entrance during construction, Structure 3.3b.



Figure 2.18 Completed earth cover, Structure 3.3b.

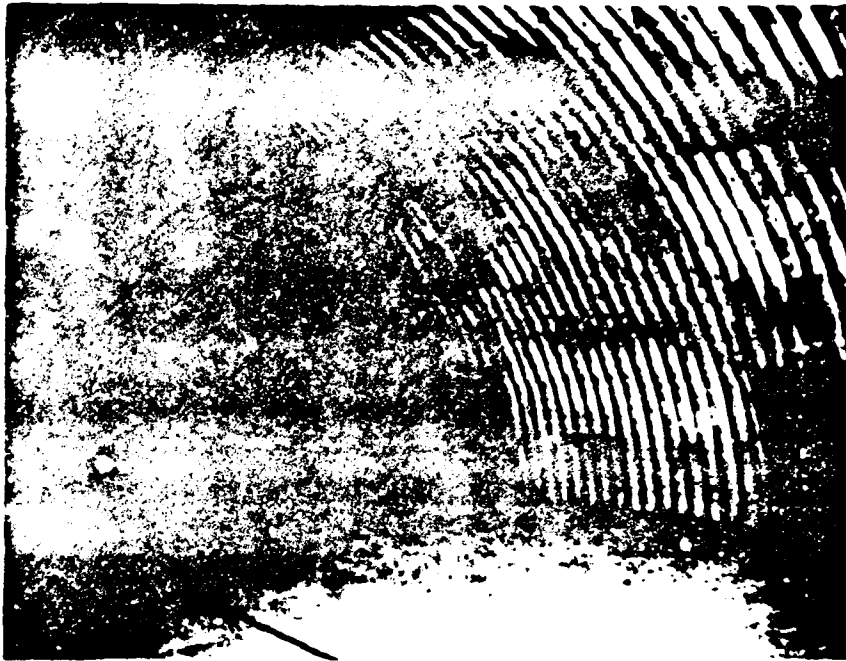

Figure 2.19 Interior view, Structure 3.3b.

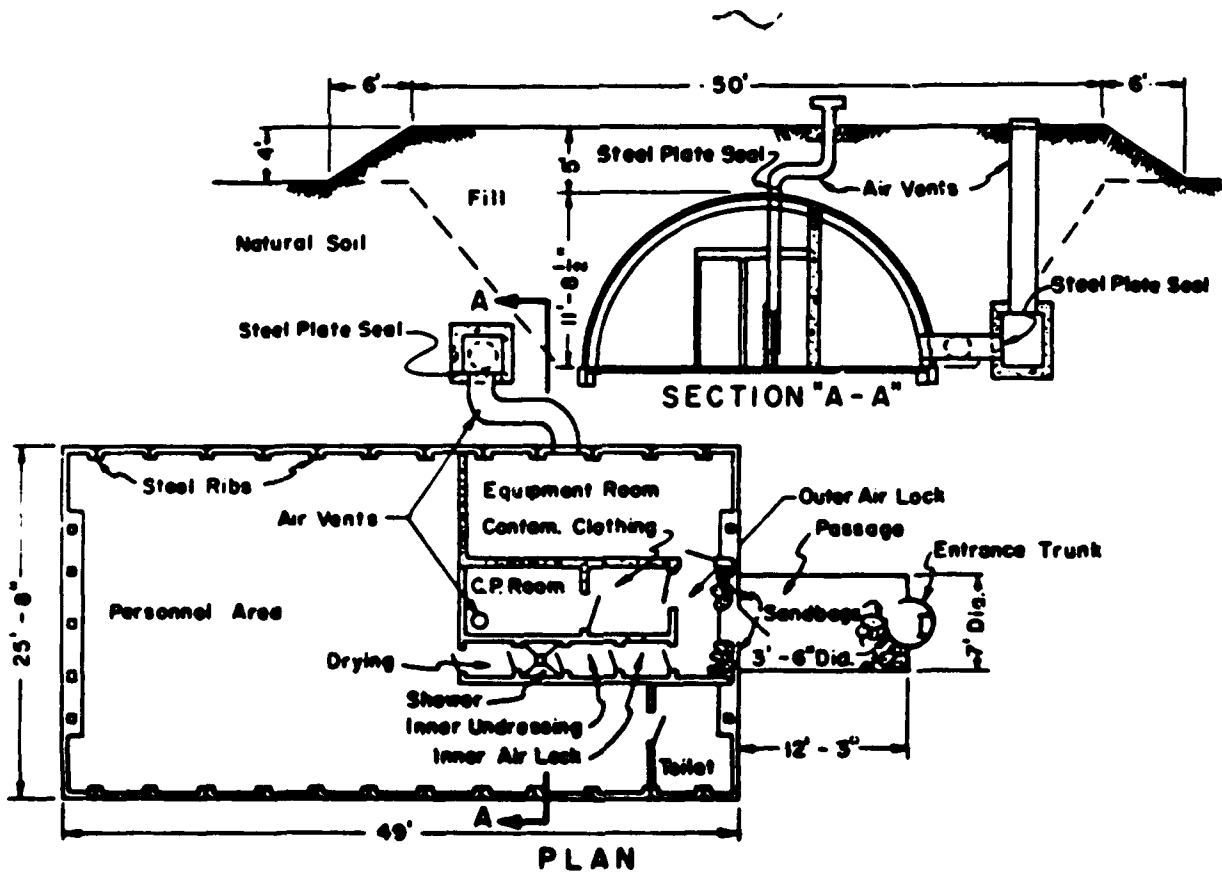

Figure 2.30 Plan and section of Structure 3.3c.

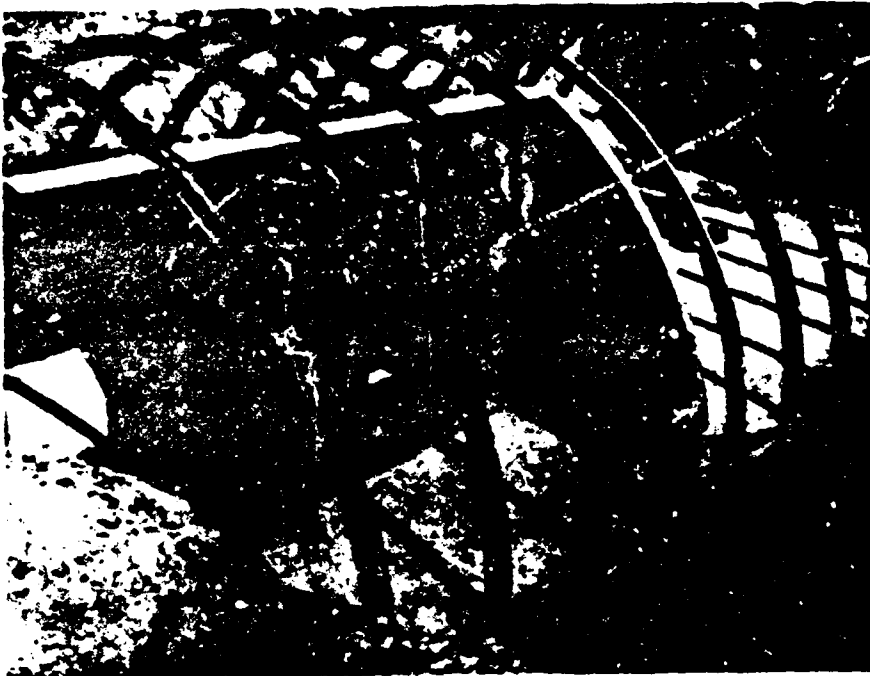

Figure 2.21 Steel arch ribs, Structure 3.3c. Provision for deflection of ribs was made at top of concrete bulkhead. Concrete bulkhead was used in this case to provide shielding of personnel area from radiation entering ventilation duct.

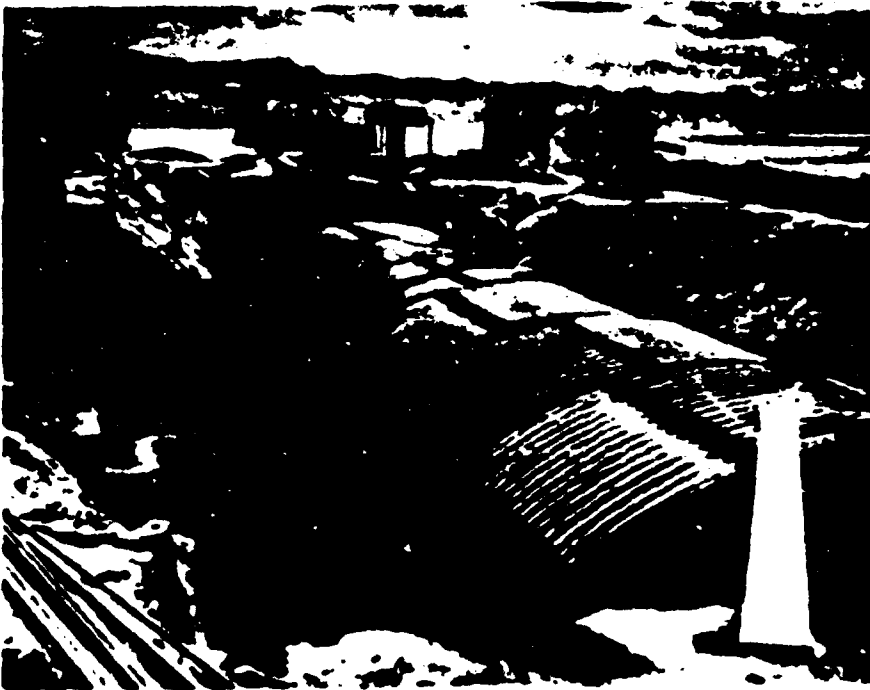

Figure 2.23 Overall view prior to backfilling, Structure 3.3c.



Figure 2.23 Access entrance during construction, Structure 3.3c.

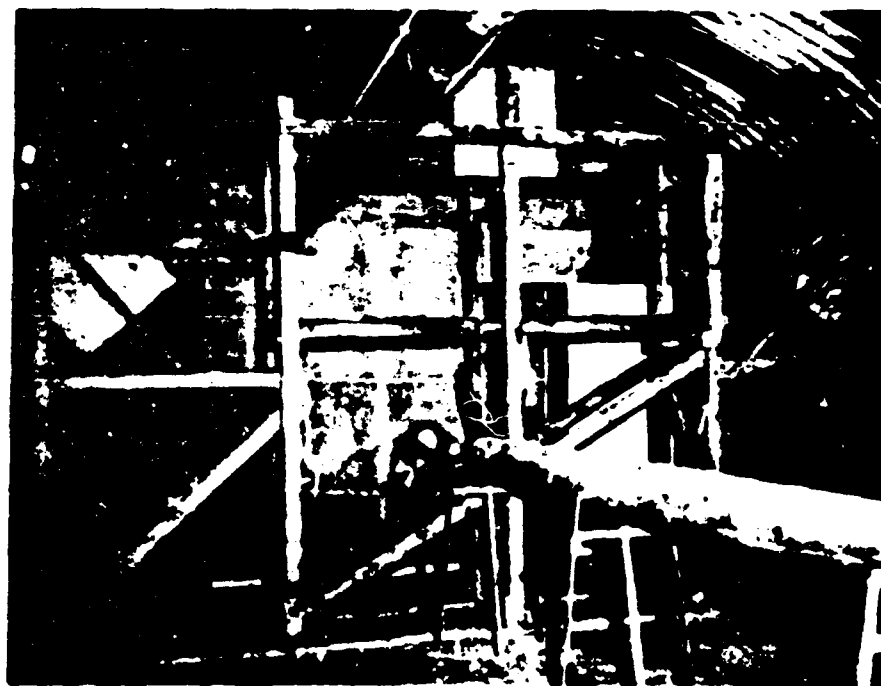

Figure 2.24 Interior view, Structure 3.3c.

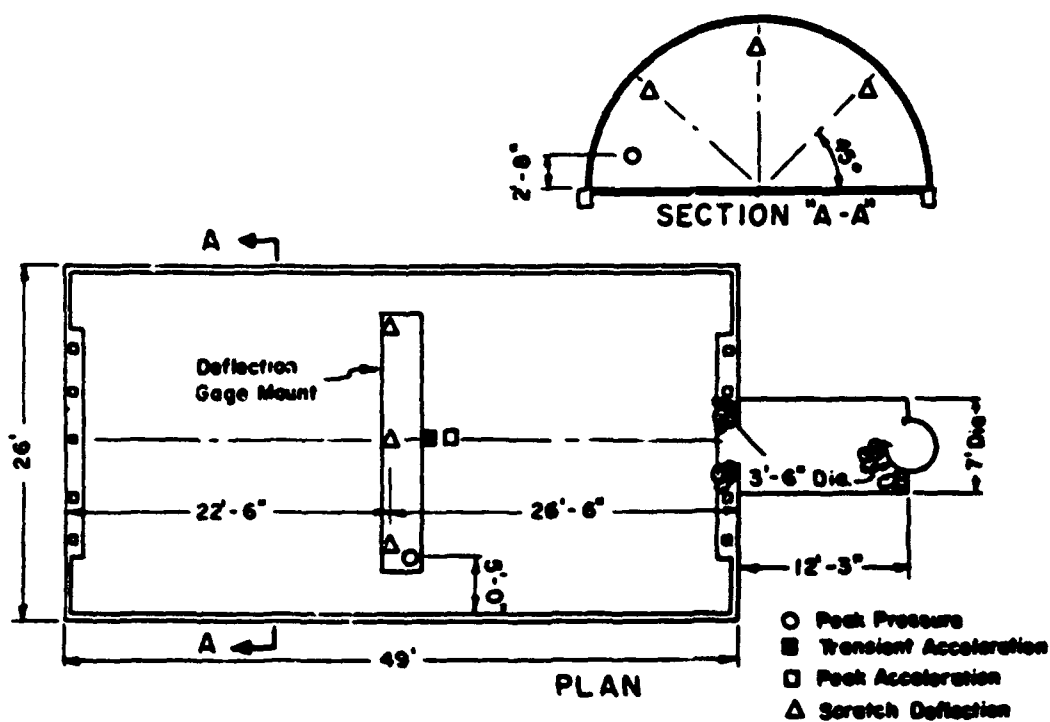

Figure 2.25 Gage location.



Figure 2.26 Recovery tube prior to backfilling.



Figure 2.27 Flexible hose in recovery tube.

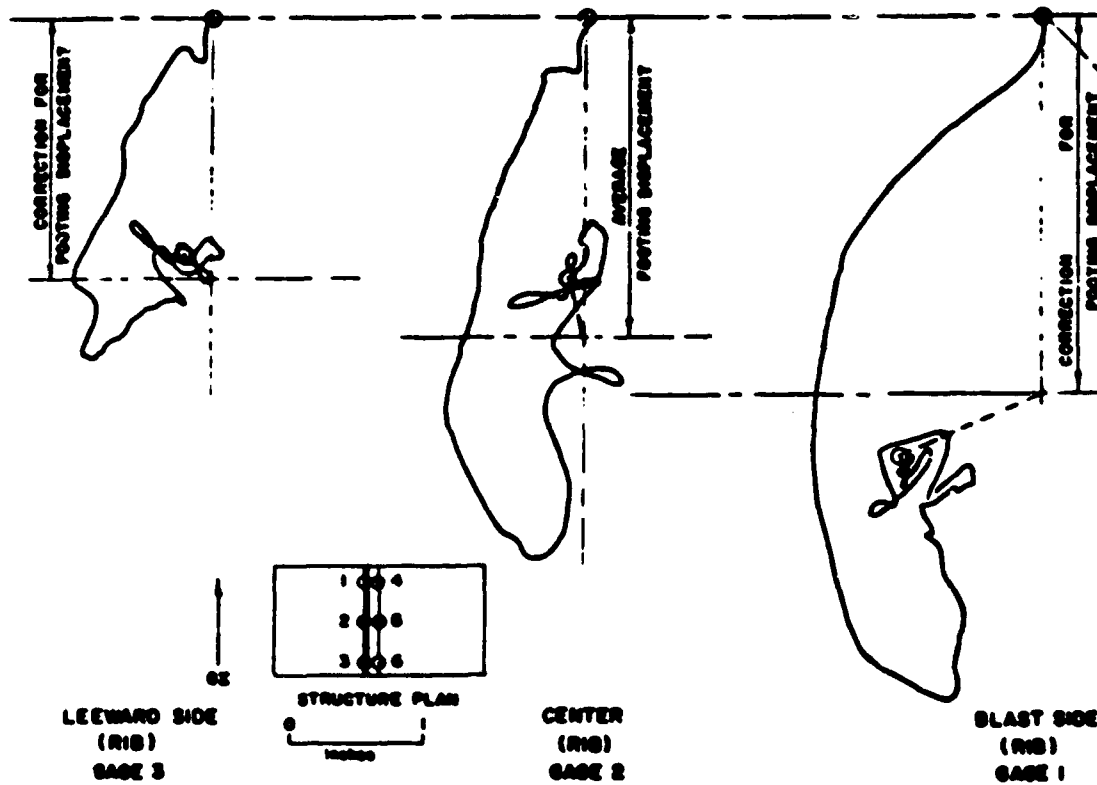

Figure 2.28 Deflection records at rib, Structure 3.3a.

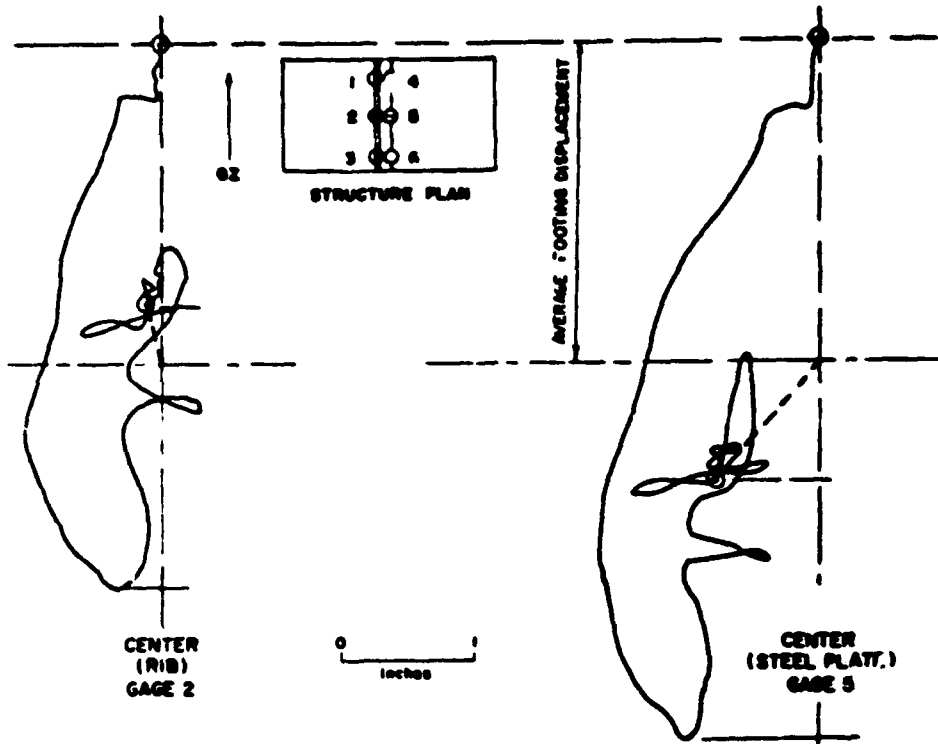

Figure 2.29 Deflection records at crown, Structure 3.3a.



Figure 2.30 Deflection records, Structure 3.3b.

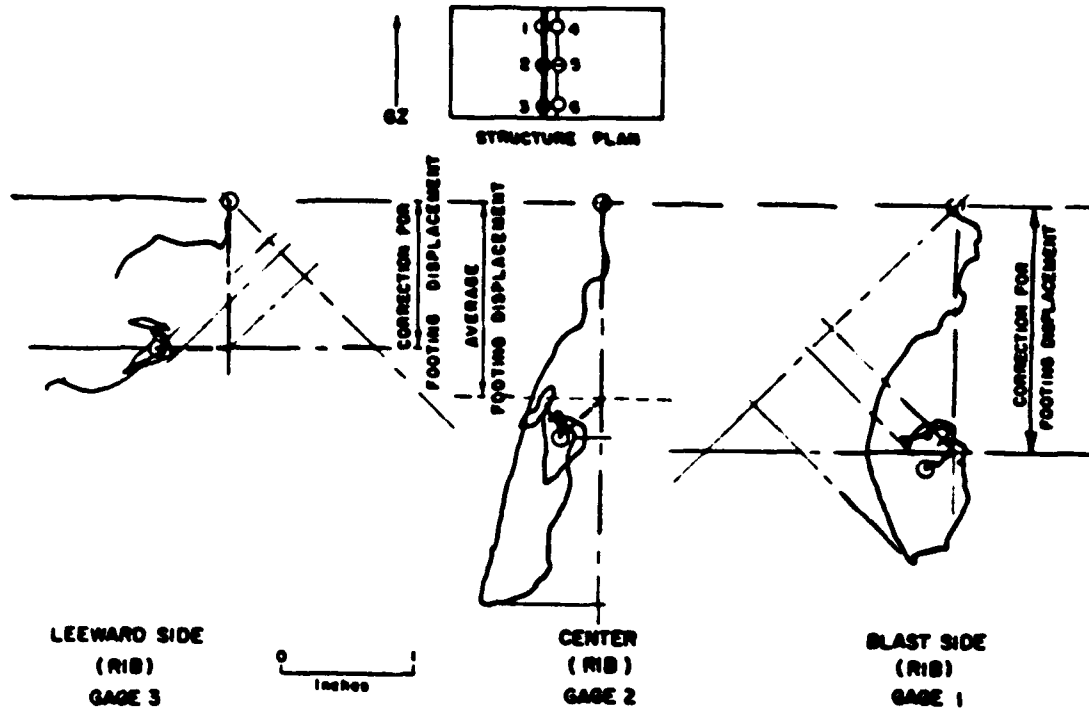

Figure 2.31 Deflection records at rib, Structure 3.3c.

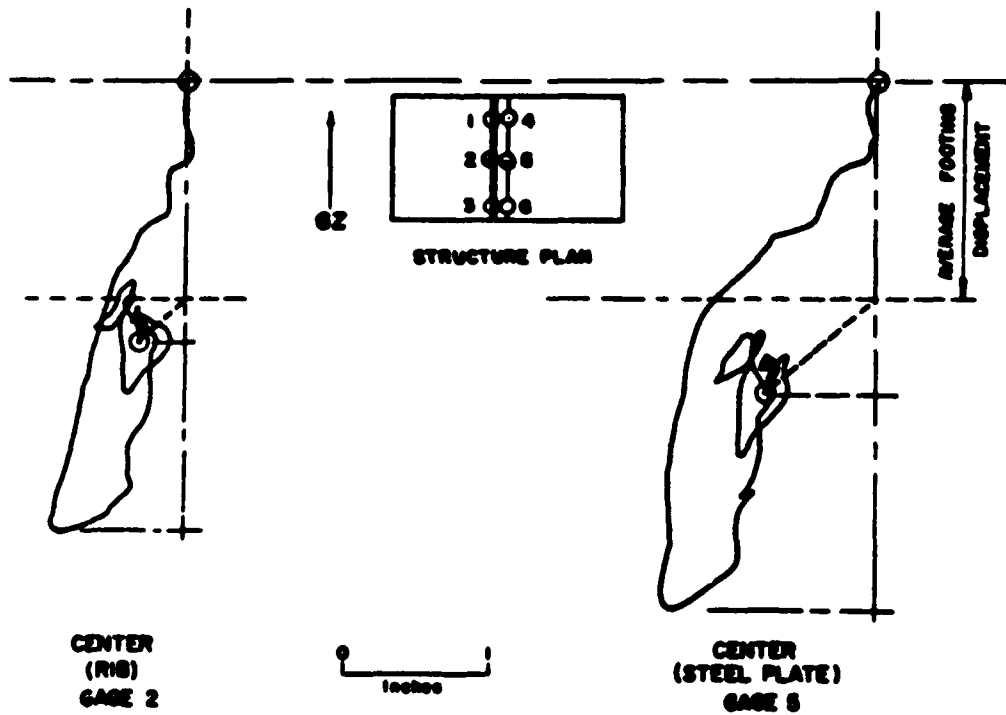

Figure 2.32 Deflection records at crown, Structure 3.3c.

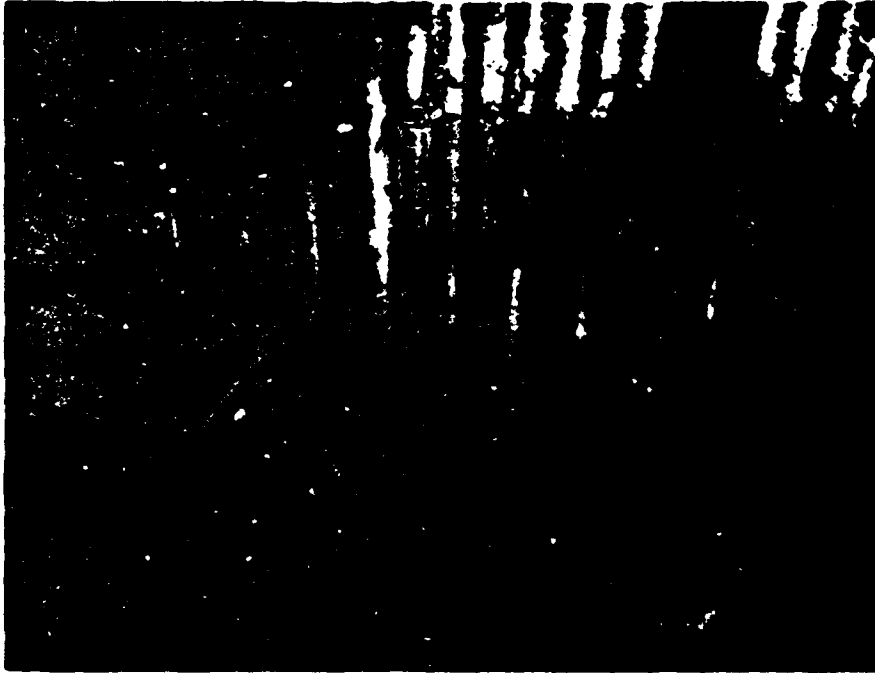

Figure 2.33 Footing position on blast side of Structure 3.3a (pre-shot).

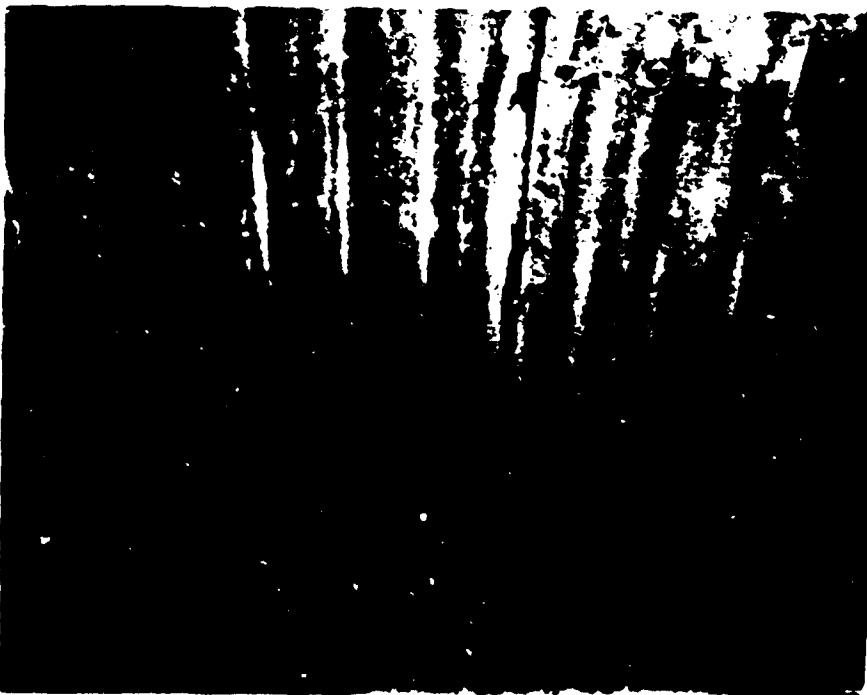

Figure 2.34 Footing position on blast side of Structure 3.3a (post-shot).

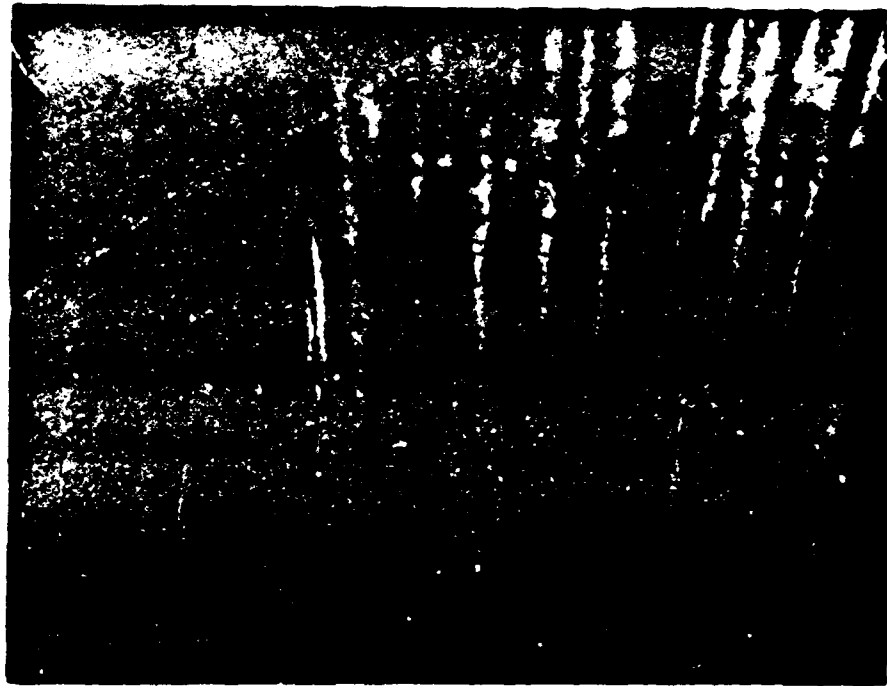

Figure 2.35 Footing position on leeward side of Structure 3.3a (preshot).



Figure 2.36 Footing position on leeward side of Structure 3.3a (postshot). Footing was displaced $1\frac{3}{4}$ inch relative to floor slab at this point.



Figure 2.37 Blast side of Structure 3.3a showing crack in floor slab (postshot).

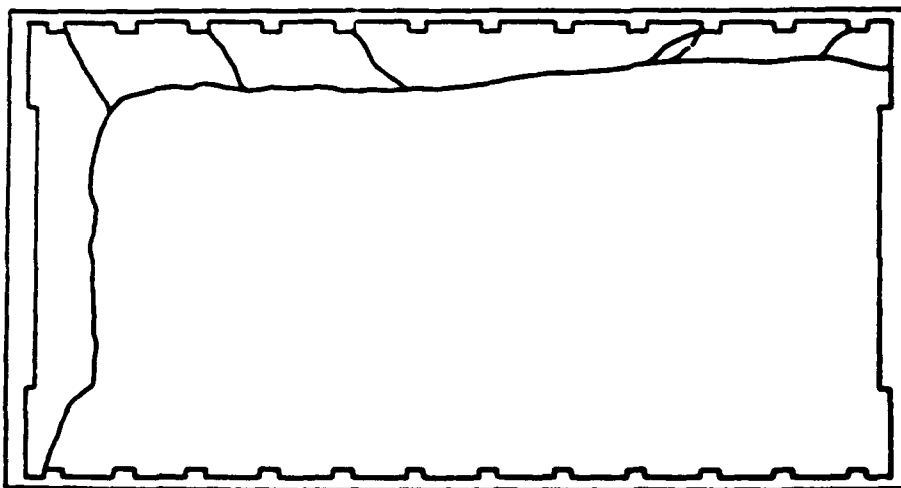

GZ

Figure 2.38 Crack pattern of floor, Structure 3.3a.

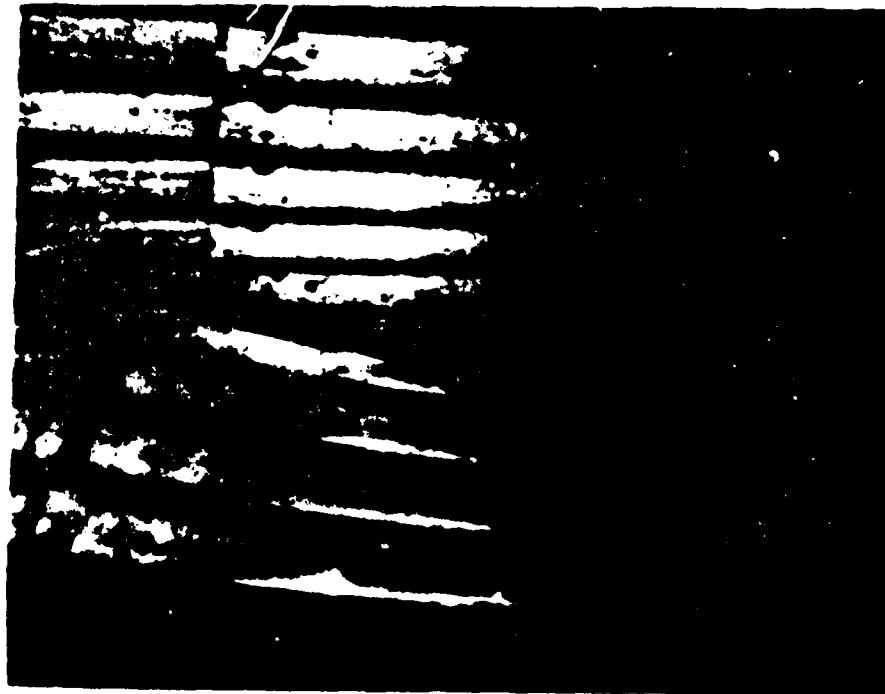

Figure 2.39 Corner view of Structure 3.3a (preshot).



Figure 2.40 Corner view of Structure 3.3a (postshot).
Footing displacement was less at ends of structure
than along sidewalls.



Figure 2.41 Earth-cover configuration of Structure 3.3a (preshot).



Figure 2.42 Earth-cover configuration of Structure 3.3a (postshot). Note slight streamlining of edges.



Figure 2.43 Footing position on blast side of Structure 3.3b (preshot).



Figure 2.44 Footing position on blast side of Structure 3.3b (Postshot). Footing was displaced $1\frac{1}{2}$ inches relative to floor slab at this point.



Figure 2.46 Corner view of Structure 3.3b (postshot). Note that the crack at corner of footing was widened from that shown in the preshot view.

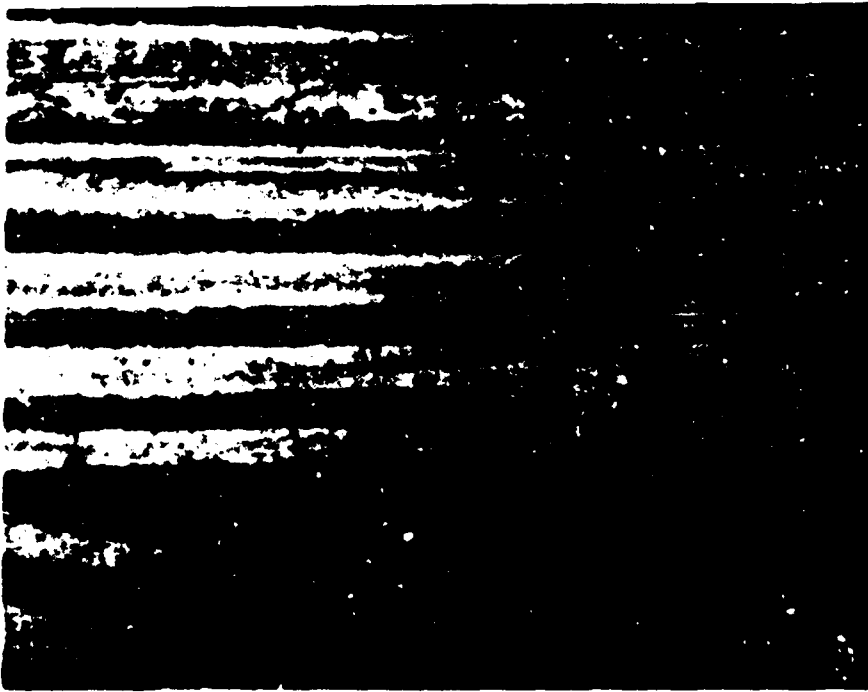

Figure 2.45 Corner view of Structure 3.3b (presbot).



Figure 2.47 Footing position on blast side of Structure 3.3c (preshot).

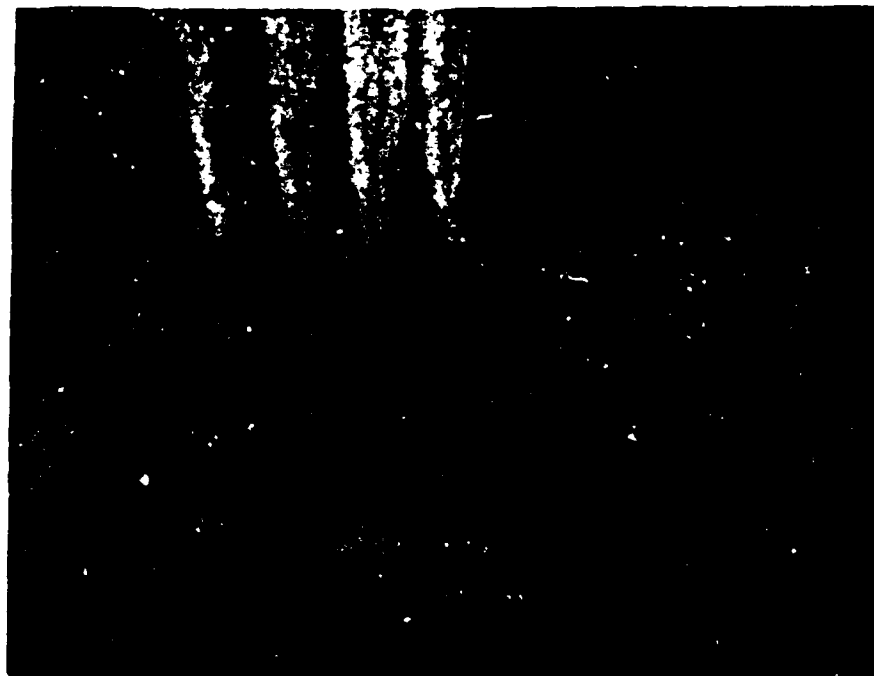

Figure 2.48 Footing position on blast side of Structure 3.3c (postshot).



Figure 2.49 Footing position on leeward side of Structure 3.3c (pretest).



Figure 2.50 Footing position on leeward side of Structure 3.3c (post-test). The footing was displaced 1 inch relative to floor slab at this point.



Figure 2.51 Earth-cover configuration of Structure 3.3c (preshot).



Figure 2.52 Earth-cover configuration of Structure 3.3c (postshot). Note streamlining of edges.

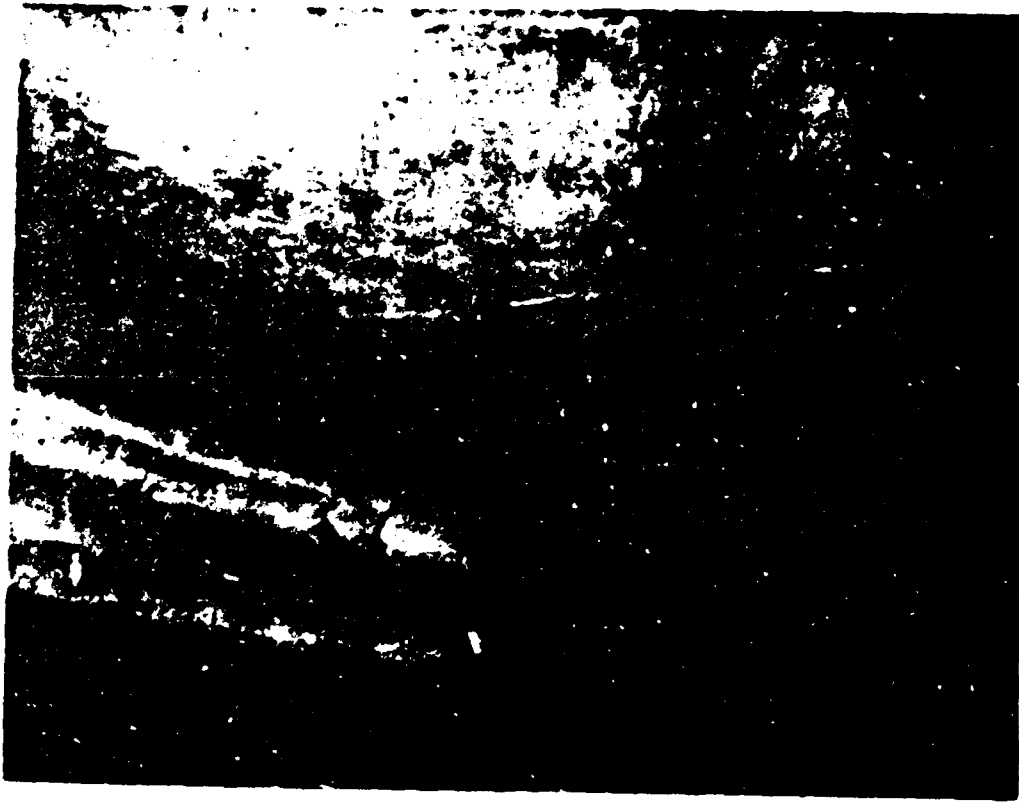

Figure 2.53 Metal closure at equipment-room concrete bulkhead, Structure 3.3c (pre-shot).



Figure 2.54 Metal closure at equipment-room concrete bulkhead, Structure 3.3c (post-shot).

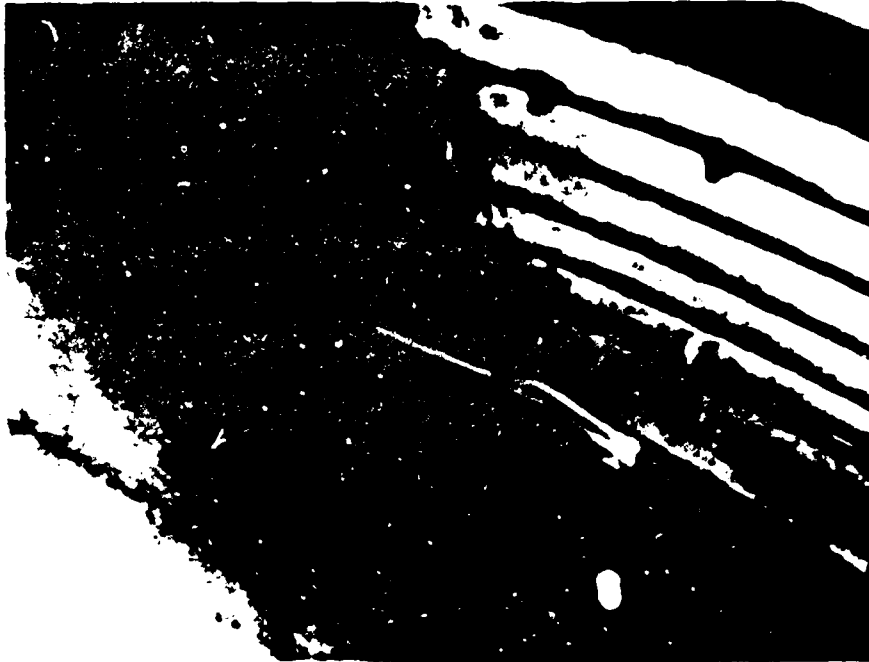

Figure 2.55 Metal closure at equipment-room concrete bulkhead, Structure 3.3c (preshot).

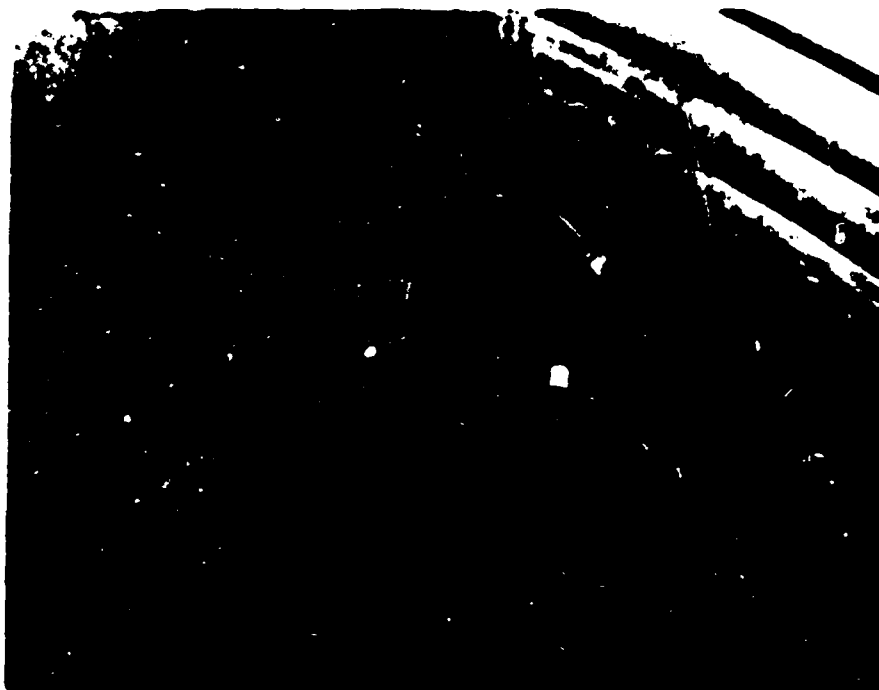

Figure 2.56 Metal closure at equipment-room concrete bulkhead, Structure 3.3c (postshot). Slight gap existed between closure plate and concrete bulkhead.

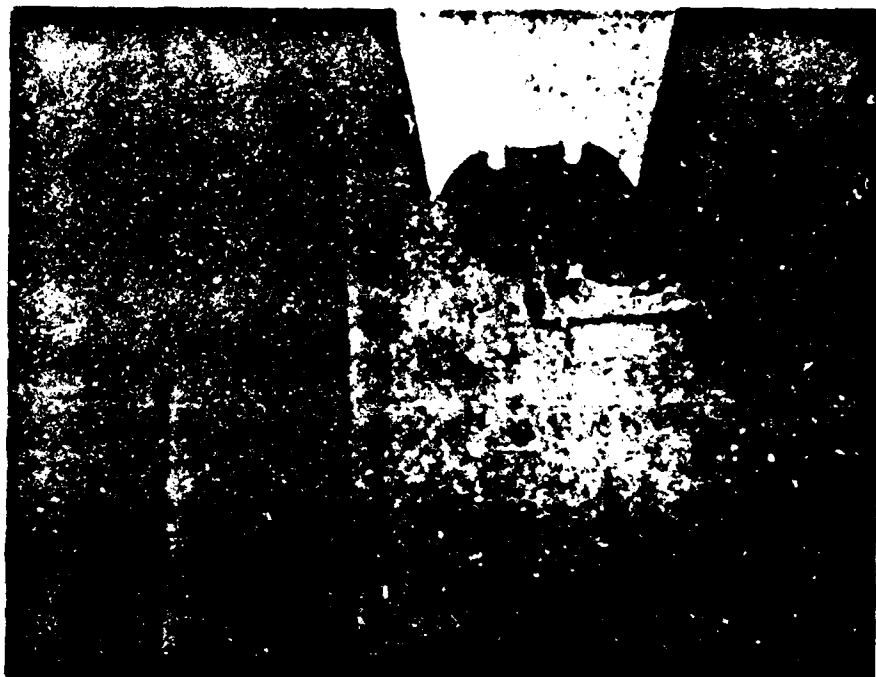

Figure 2.57 Ventilation pipe and lighting fixture, Structure 3.3c (preshot).

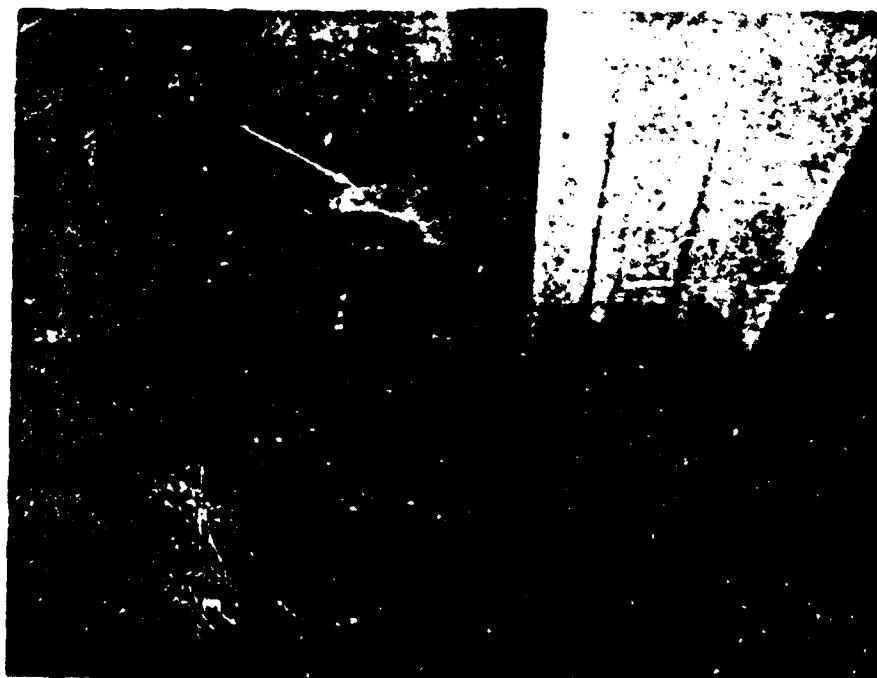

Figure 2.58 Ventilation pipe and lighting fixture, Structure 3.3c (postshot). Note break in asbestos board, due to movement of pipe relative to board.



Figure 2.59 Water and ventilation pipes above Structure 3.3c (preshot).



Figure 2.60 Water and ventilation pipes above Structure 3.3c (postshot).

Chapter 3

TESTS OF BLAST CLOSURE VALVE

3.1 BACKGROUND

Included in a typical shelter design for atomic, biological, and chemical warfare are provisions for forced ventilation. Such a ventilating system, using a protective-collector filter system, is extremely vulnerable to air-blast pressure entering through the ductwork. A blast closure valve is necessary to prevent damage to both the filter system and shelter contents. For instance, shock tube and field tests have shown that both fiberglass dust-stop filters and porous paper filters are severely damaged by overpressures of a few pounds per square inch. For the fiberglass filters, pressures of 0.5 psi produce moderate damage, 1.5 psi severe damage. Properly supported porous paper filters suffer little if any damage at about 2 psi, but complete failure at 6.0 psi.

The debilitating effects of overpressure and shock waves on humans is less well established, but sudden pressure rises of 5 psi have been known to cause rupture of the eardrum.

3.2 PROCEDURE

A blast closure valve was a part of the basic design of Structure 3.3c. However, to avoid possible failure of the other tests in the structure if the valve malfunctioned, the ventilating ducts were sealed. The valve was attached to a separate plenum (Figures 3.1 and 3.2). This valve, rated at 600 cubic feet per minute (cfm) and designated as the E19R1, was developed for the Bureau of Yards and Docks by the Army Chemical Center. It had previously been tested in a shock tube (Reference 21).

The test plenum contained approximately 215 ft³, or far less than the shelter proper; this will affect interpretation of the results. Had the chamber in which the valve was located been larger, the pressure rise would have been less.

A view of the completed air-intake ducting and plenum access hatch are shown in Figure 3.3, with schematic details of the valve mechanism in Figure 3.4.

3.3 RESULTS

The peak overpressure observed at earth surface was 60 psi. The duration of the positive phase was 345 msec. The peak internal pressures in plenum were 0.32 psi (positive) and 1.20 psi (negative).

3.4 DISCUSSION

In interpreting the results tabulated, it should be kept in mind that the plenum might be larger or smaller than practical designs of expansion chambers to be used in working shelters. The 0.32-psi pressure rise in a 215-ft³ expansion chamber would represent a net airflow of approximately 6 ft³. The capabilities of the blast closure valve in a particular situation will depend upon the expansion-chamber design. Inasmuch as the 12,500 ft³ of the shelter chamber proper is too large for a significant pressure rise to occur at these flow rates, the apparent leakage of the device need be investigated only as it affects the integrity of the collective protective filters, and when a plenum is used. Because of the long duration and poor seating of the valve compo-

nents under negative pressure, this is apparently the critical situation.

Shock tube tests (Reference 21) of the valve which at BNL revealed relatively high pressure rises in a very small (2 ft) expansion chamber at a shock strength of 1.8. The prospective user of this valve should consider very carefully the related aspects of expected peak positive pressures, duration times, and negative pressures on the sizing of the expansion chamber. Finally, it is certain that this valve cannot be expected to seal effectively against negative pressures—it can function properly in one direction only by virtue of its basic design. However, if the expected maximum negative pressure is within the design tolerances of the collective protective filter, the expansion chamber need only be designed for the positive phase. Under the conditions of test, the pressures were within the limits that the filters could tolerate.

A comprehensive study of corrosion of various parts of this unit was made in salt air (Reference 32) from a windborne spray. The results indicated that the mild steel parts should be replaced with more durable metal or treated to avoid corrosion. Neoprene foam rubber should be used as the gasket material. In the tests during Operation Plumbbob, the use of a more durable and softer sealing gasket might have materially reduced air leakage in either direction.

3.5 CONCLUSIONS

The blast valve appears to be adequate in sealing against the positive pressures to 60 psi, for 345 msec.

Capabilities of the valve at various other pressures are not known from the available test data.

3.6 RECOMMENDATIONS

The valve should be considered satisfactory only for the maximum pressure conditions under which tested.

Additional performance data should be obtained by extensive tests over a wide pressure range in a suitable blast-simulating device. Further, particular attention should be given to the negative phase in any design situation in which it is expected that the pressure will exceed the design tolerance of the collective protective filters. It appears impracticable to redesign this valve for protection during the negative phase, but redesign of the gasket and substitution of a better sealing material might eliminate most of the leakage.

Further engineering development of this valve is warranted and recommended.

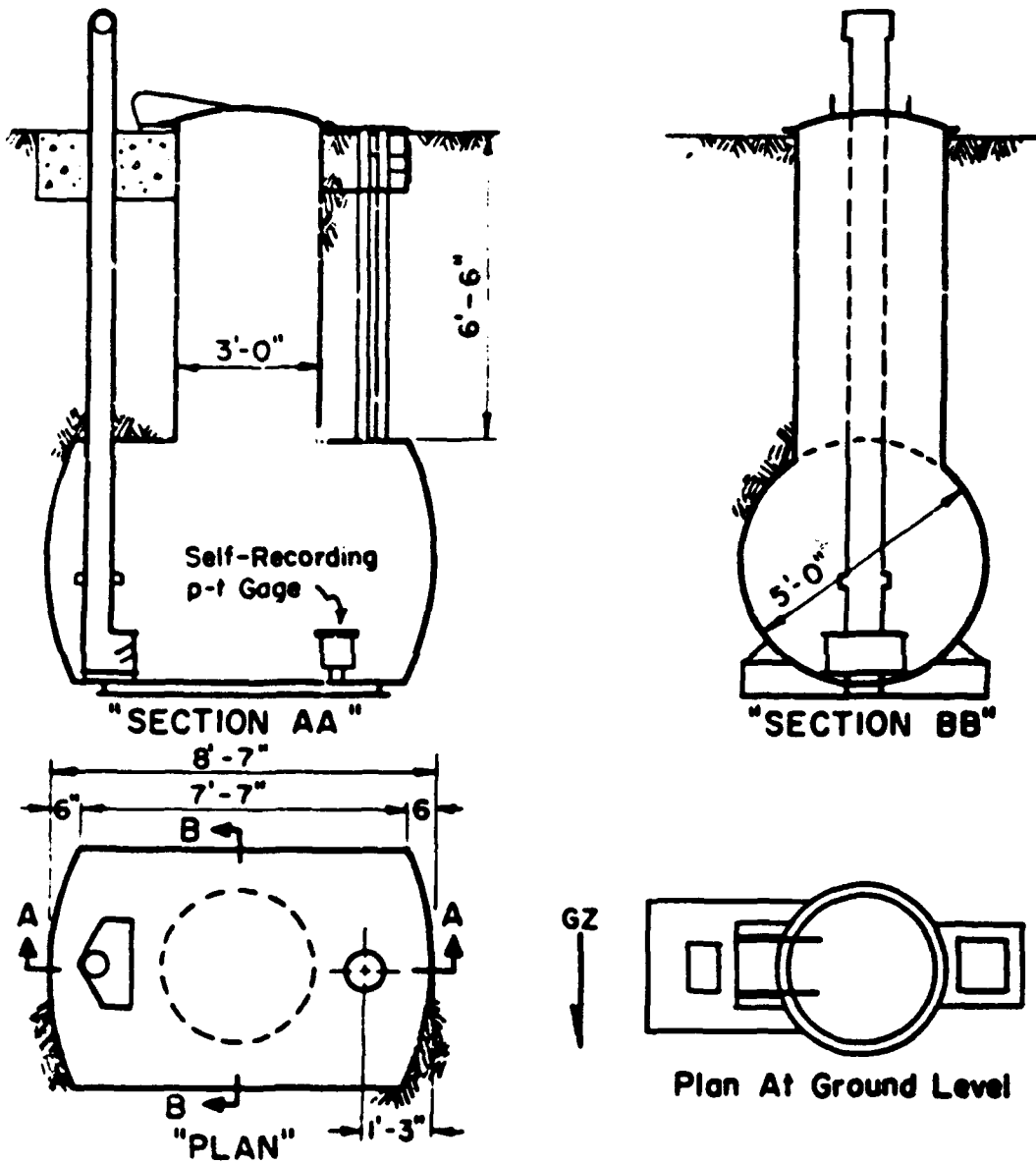

Figure 3.1 Pressure plenum for blast closure valve test.

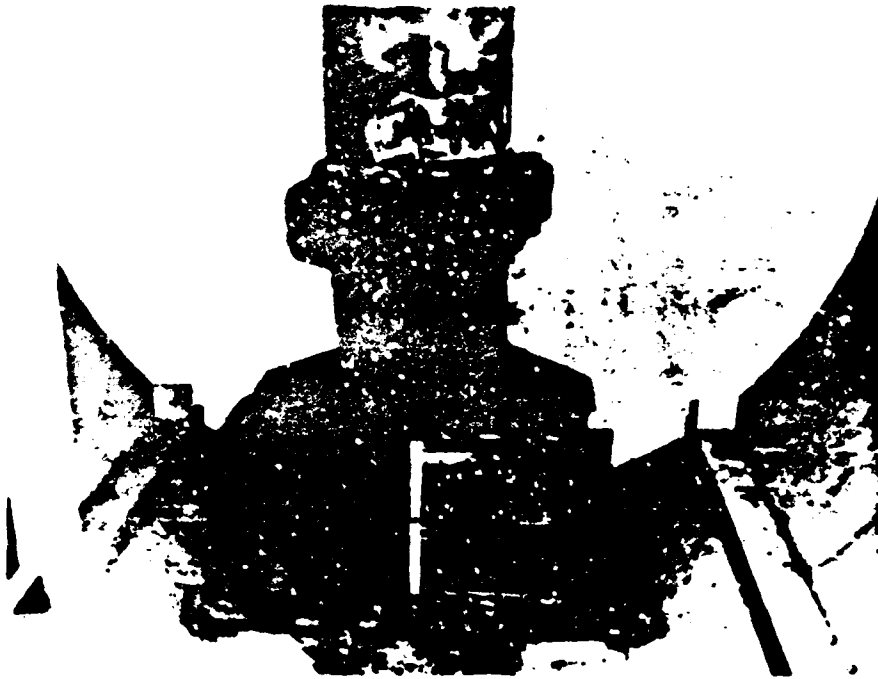

Figure 3.2 Blast closure valve installed in test plenum.

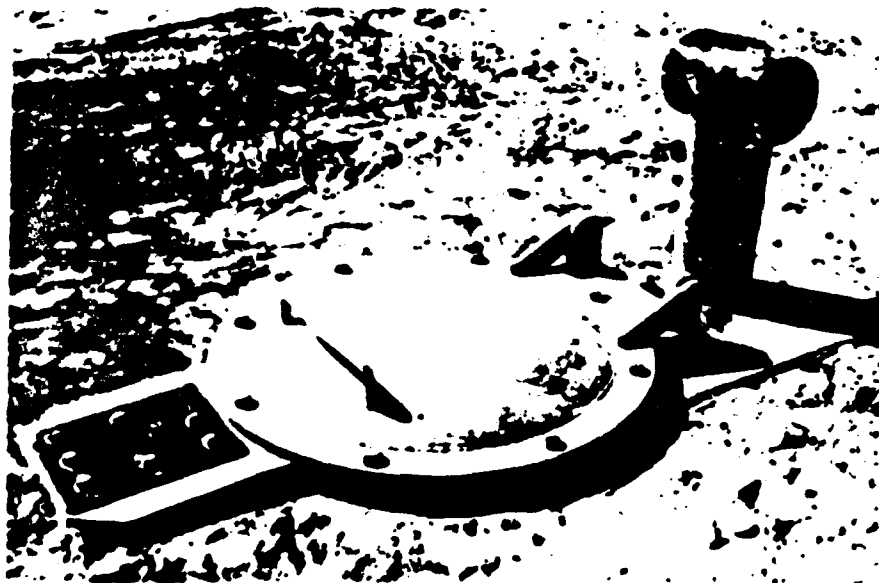

Figure 3.3 Blast closure valve test plenum air intake and access hatch after backfilling.

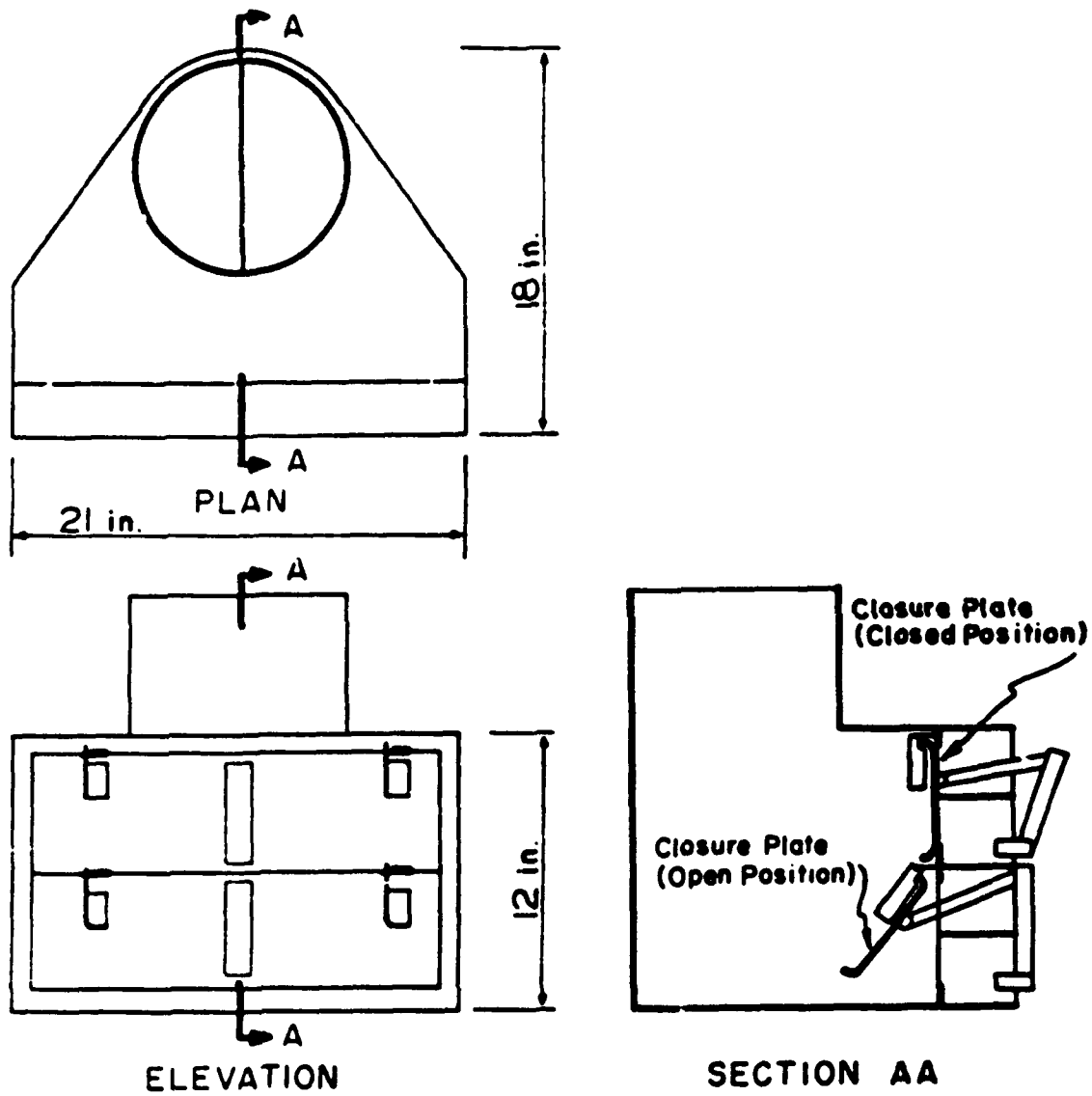

Figure 3.4 Schematic representation of blast closure valve.

Chapter 4

PIT ENCLOSURES FOR EMERGENCY POWER GENERATORS

4.1 BACKGROUND

The requirement for electric power to drive the necessary ventilating or air-conditioning equipment, in addition to the more commonly encountered lighting, pumping, and cooking loads, makes the role of the auxiliary emergency power supply paramount in the successful functioning of a protective shelter.

A first inspection of the problem indicates that most of the components of portable engine-driven generator sets will not be adversely affected by static pressures of the order of 100 psi. Precautions must be taken to insure adequate venting of closed containers, to avoid implosion. There are, however, a number of typical blast-loading components which present large sail areas and thus are sensitive. Sheet-metal enclosures and instrument panels are especially vulnerable.

Because of the noise, vibration, and heat from an engine-driven set, it must be installed in an enclosure separate from the personnel shelter. The tests described here are of a first design of partially enclosed pit shelters for generator sets; the principal design criteria were to protect the units from high drag loading and missiles. The shelter was not designed to provide a suitable environment for their storage, maintenance, or operation.

4.2 PROCEDURE

The shelters consisted of pits slightly larger in plan than the test generator sets. They were constructed to resist deformation under the test conditions but were without cover except for a metal grill (Figures 4.1, 4.2, and 4.3).

Six units—three 15 kva and three 5 kva—were placed adjacent to underground Structures 3.3a, 3.3b, and 3.3c. Structure 3.3a was located in the 100-psig overpressure region, 3.3b and 3.3c were in the 60-psig overpressure region. In each case, the long side of the pit was oriented toward ground zero, and was, therefore, parallel to the shock front. This is a preferred orientation, because it minimizes the time for pressure buildup as the pressure wave passes over the pit. The practical application of the principle may be difficult because the blast might come from a less favorable direction.

4.3 RESULTS

The damage sustained by individual components of the six portable generator sets is tabulated in Table 4.1. Postshot views of some of the pits and generator sets are shown in Figures 4.4, 4.5, and 4.6.

Neither of the units was operable at the 100-psig range, and only one of the four was immediately usable at the 60-psig range. Any of the six units could have been repaired with a moderate expenditure of time in a shop, under favorable conditions. The degree of fallout contamination would determine when these repairs could be made.

These favorable remarks should be tempered with the observation that there was a marked lack of flying debris, flammable materials, and the like, which might have been sources of damage in a more typical residential or industrial location. On the other hand, the loose con-

dition of the surface soil typical of the test site probably produced much heavier dust loading and contamination than would be experienced in a typical location.

All units were displaced upon their foundations, but it is not clear whether this resulted from reflected pressures from the pit walls or from ground accelerations. In any event, they could have been used without remounting. The evidence points to ground accelerations as the cause, as there was no evidence of high horizontal forces on the sheet metal, as would be required to dislodge a heavy engine.

4.4 DISCUSSION

Because the damage was patently too high, the pit design is not considered practicable for a standby power source for shelters. For the less demanding case of a facility in which the requirement for some repair before use is tolerable, protection was nearly adequate at even 100-psi overpressure.

During filling of the generator pits with dust-laden air, the principal direction of flow would be downward, and maximum damage to the upper, horizontal surfaces of collapsible sheet-metal components would be expected. Damage was most severe to the horizontal surfaces of the engine shrouds of the engines so equipped. The sheet metal might well be ignored.

More important, the slight dishing inward of the upper tanks of all radiators apparently compensated for inadequate venting; significant damage to the fragile cooling system was thus prevented. Similarly, five out of six of the gasoline tanks suffered minor damage from the high downward translational forces but little if any bad effects from crushing. The fuel tank of the 5-kva unit adjacent to Structure 3.3a suffered relatively greater distortion than the others, and fuel was lost as a result.

Although it cannot be definitely determined, this particular fuel tank was probably only partially full; therefore, it suffered a fate similar to that of the tool boxes, all of which collapsed or were dismembered by external pressure. This would be the expected fate for light, unsupported sheet-metal structures at the pressures encountered, unless fully vented or filled with noncompressible liquid in which the pressure would rise rapidly. Full tanks appear to be preferred over half-empty ones.

On the other hand, adequate venting of several of the surviving tanks led to the introduction of intolerable amounts of dirt into the fuel system. Devices for liberal venting with filtered air are indicated for all closed containers.

The dismemberment, bending, or detachment of miscellaneous ground straps, brackets, governor rods, and the like, indicate the necessity for design against dynamic loads for such unsupported elements. It would be desirable if they were eliminated by selection of more suitable generator units incorporating internal governors.

An excellent example of the necessity of modifying generator components to increase the allowable pressure is found in the carburetor float. The carburetor proper, largely full of gasoline and well vented, is practically insensitive to pulsed overpressures. The float, usually of a light pressed-brass tank construction and not vented, is extremely vulnerable. Substitution of a cellular plastic material for the metal float might provide a suitable solution.

As compared to the gasoline types, diesel engines have characteristics which make them much more desirable as standby emergency generators for shelters; however, they are more expensive. In diesel engines, the generally heavy construction, internal governors, heavy cast radiator tanks and crankcase pans, and the like, might obviate the necessity for modifications. Furthermore, diesel engines do not have carburetors and, usually, do not have external governor linkages. Reduced fire hazard from spilled or leaking diesel fuel, compared with gasoline, would be a distinct advantage.

Even though all of the generators suffered damage, and the application is in general not considered satisfactory, damage was light when compared with what would have been predicted for unshielded units at the same locations (Reference 19). However, it cannot be stated categorically that the protection afforded by the simple pits was significantly superior to that which

would have been achieved by the use of masonry parapets as shown in Reference 19.

The time-pressure curve at critical points within the pits was not obtained in the tests, but some attempt is being made to establish the significant physical parameters of the total pit-generator arrangements which were useful in reducing shock reflected pressures, dynamic pressures, and pressure rises in the system. In the absence of model studies or an adequate mathematical treatment, the results of this investigation are largely conjectural. A series of large-scale, shock-tube and or high-explosives model tests is required. The latter could be accomplished best in a large three-dimensional blast simulator. The need to delineate the role of the contoured gratings, ratios of opening area to pit volume, and generator location within the pit to minimize shock entrance, drag forces, pressure rise, and damage from shock reflection is indicated.

4.5 CONCLUSIONS

1. The partial protection afforded the generator sets in open pits was very good but not sufficient to warrant the use of the pits as tested at 60-psi overpressure.

2. The application of pit enclosures warrants further study and testing.

3. The individual mechanisms by which shock enters and air pressure rises in a cavity that has a large ratio of area opening to volume need both theoretical and model study to obtain a practical design method.

4. Because of their more massive construction and their lack of certain pressure sensitive components, diesel-powered generator sets should fare better in semiexposed situations than the gasoline units tested here. In the absence of further testing, diesel units should be used.

5. Insufficient information is available for determining what improvements should be incorporated in pit design.

4.6 RECOMMENDATIONS

1. Fully instrumented model or full-scale, three-dimensional blast-simulator studies of shock propagation into open pits should be made to allow rational design for future full-scale tests. Full-scale testing of appropriate mechanical equipment in a suitable blast-simulating facility would be especially desirable.

2. Future full-scale tests should include diesel engines selected for component durability, as well as stock gasoline engines; in the absence of further tests, diesel engines should be used.

3. Future full-scale tests should be fully instrumented for pressure rise and accelerations at probable points of maximum damage.

TABLE 01. TABULATION OF GENERATOR DAMAGE

All estimates of repair time are based on operation in a shop

Part Name	Adjusted to Structure 3.3a		Adjusted to Structure 3.3b		Adjusted to Structure 3.3c		Type of Load
	3-4-5 Damage	Repair Time hr	3-4-5 Damage	Repair Time hr	3-4-5 Damage	Repair Time hr	
Radiator							
Top tank	Cracked in Beats	Yes 1/2	Cracked in Beats	No 1/2	Cracked in Beats	No 1/2	Pressure drag
Front gland	Beats	No	Beats	No	Beats	No	Drag
Top tank	Beats	No	Beats	No	Beats	No	Drag
Bottom tank	Beats	No	Beats	No	Beats	No	Drag
Overflow line	Beats	No	Beats	No	Beats	No	Drag
Full cap	Beats	No	Beats	No	Beats	No	Drag
Carburetor							
Body							
Flint							
Flint lever 1	Cracked in Beats	Yes 1/2	Cracked in Beats	No 1/2	Cracked in Beats	No 1/2	Pressure Pressure
Air cleaner							
Automatic choke							
Automatic head							
Automatic head housing							
Fuel supply system							
Supply line							
Top filter and cap							
Instruments:							
Gage glass on							
Pressure light							
Temperature (dashboard indicator)							
Wiring							
Generator ground							
Armature, generator							
Terminal block							
Generator:							
Control rod							
Spring adjustment lever							
Regulator, generator							
Electrical panel base							
Electrical panel housing							
Top tank							
Crashbox:							
Oil drain pipe							
Breaker pipe							

1 Fully operative at end of test 2 Better after first start 3 Afternoon: manual operation 4 Small portable tank 5 Depends upon mode of operation

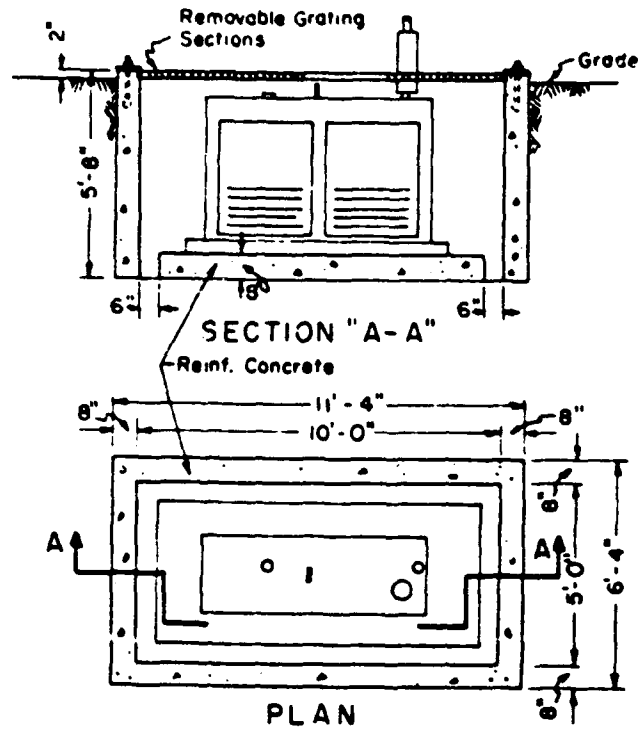

Figure 4.1 Test pit, 15-kva generator set.

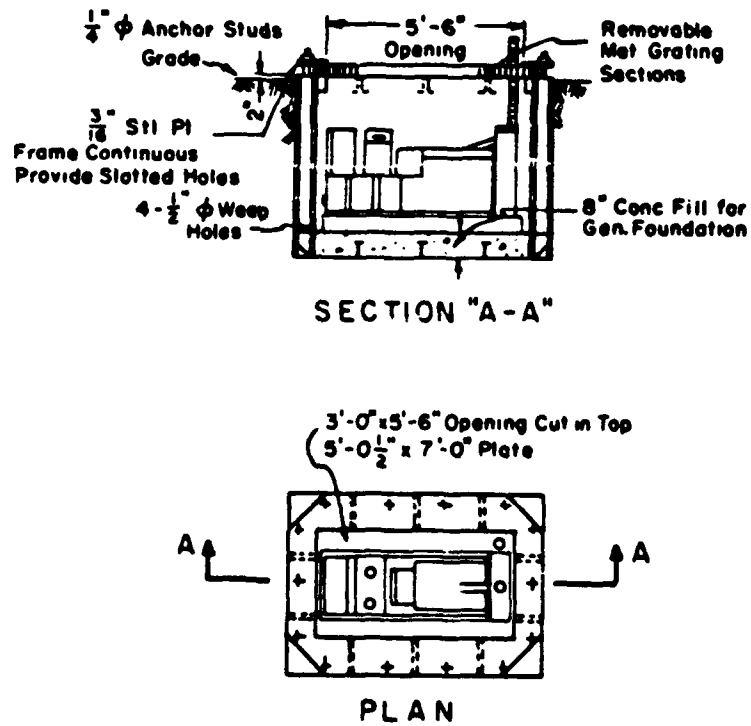

Figure 4.2 Test pit, 5-kva generator set.



Figure 4.3 Generator protective pit with grating in place.



Figure 4.4 Postshot view of generator pit.

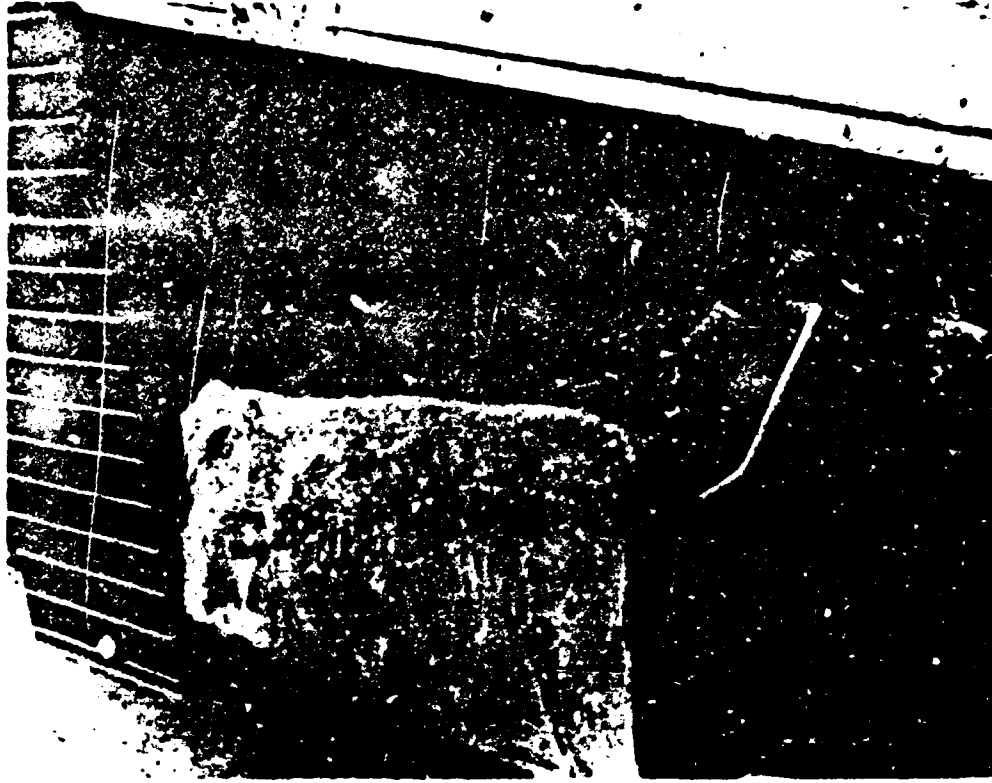

Figure 4.5 Postshot view of generator in pit, with pit grating removed.



Figure 4.6 Postshot view of generator without sheet-metal shrouding, with pit grating removed.

Appendix A

CONSTRUCTION

A.1 RESPONSIBILITIES

Construction for this project was accomplished by means of a cost-plus-fee contract administered by the Armed Forces Special Weapons Project (AFSWP) [now Defense Atomic Support Agency (DASA)] and the Atomic Energy Commission (AEC). The three stock structures (unmodified) and test generators were furnished by the Navy.

The excavation survey for this project commenced at Frenchman Flat at NTS 5 March 1957, actual construction started 19 March, and backfill had been completed on the final structure 30 May. Reynolds Electrical and Engineering Company (REECO) erected the structures with Holmes and Narver (H&N) serving as general construction inspector. The Bureau of Yards and Docks project officer served as technical construction inspector at the site in connection with critical construction details. A soil-survey program was conducted by the Waterways Experiment Station (WES) (Reference 22).

A.2 CONSTRUCTION DETAILS

A.2.1 Structures. Schematic drawings of all structures are included in Chapter 2. Inasmuch as the successful design of personnel shelters and/or an attempt to duplicate test conditions depends upon detailed consideration of architectural, structural, electrical, and mechanical elements, detailed drawings of these elements are presented in Figures A.1 through A.6.

Photographs taken during construction (Figures A.7 and A.8) are included for clarification of the numerous details critical to the successful erection of the structures.

Selected portions of the construction specifications are listed below. The following drawings are applicable: Yards and Docks Drawings 771099, 771100, 771101, 771102, and 774892.

General description: The work will consist in general of the erection of three buried corrugated steel arch-type magazines designated as 'Structures, a, b, and c.' The magazines will be furnished to the contractor at the site by the Government; however, the contractor will not install the flat sheet steel front wing bulkheads that are furnished with the structures, but he will provide new corrugated steel front bulkheads to match the rear bulkheads of the structures, including all necessary modifications thereof. New corrugated steel culvert pipe entrance shafts and tunnels will be provided to each of the structures. The fabrication and installation of hinged hatch covers at each of the entrance shafts will be included. Structure 'a' will have steel arch ribs to strengthen the roof and side walls of the structure and timber stiffening bulkheads anchored to concrete 'deadmen' with tie rods for the front and rear bulkheads; concrete floor slab and a wood platform to receive instrumentation will be provided within the structure. Structure 'b' will be as specified for Structure 'a' except that the steel arch ribs will not be required. Structure 'c' will be as specified for Structure 'a' except that concrete and wood stud interior partitions will be provided. An 8-inch diameter steel pipe air intake to 'C.P.' room and a corrugated steel culvert pipe stack air intake to the equipment room with a reinforced concrete plenum chamber will be provided for Structure 'c', including the installation and connecting of two of the Government-furnished generator sets. Four additional Government-furnished generator sets will be installed; two at Structure 'a'; and two at Structure 'b'. Three concrete pits (indicated as 'Auxiliary Test Structure X') will be provided to receive the 15-kva generators. The fabrication and installation of an 'antibackdraft pressure relief valve' in the concrete wall of the equipment room will be included.

"SECTION 2 EARTHWORK

"Borrow Material. Earth for backfill and fill material will be furnished by the Government to the contractor for transportation by him from borrow pits located within 4 miles of the site of the work. Borrow pits shall be graded in a manner to drain properly so that the existing surface drainage will be maintained. Any surplus earth not required for filling or backfilling shall be removed and deposited within 2,000 feet of the site of the work as directed. Soil pits shall be graded in a manner to drain properly so that the existing surface drainage will be maintained.

"Excavations shall be carried to the contours, dimensions and depths indicated or necessary. Excavations carried below the depths indicated without specific directions, shall be refilled to the proper grade with thoroughly compacted suitable fill, except that in excavations for footings, or for buried concrete members the concrete shall be extended to the bottom of the excavations; all additional work of this nature shall be done at no additional cost to the Government. All excavations may be made by means of machines, except that the last 6 inches of earth and the trimming of the excavations shall be done by hand in a careful, accurate manner to the exact grades and slopes indicated or directed. Extreme care shall be exercised to shape the bottoms of excavations for circular and irregular shaped members to the contour necessary to provide conditions solid bearing for the members. Prior to backfill operations, all debris, muck and other loose silt shall be removed from the excavations.

"Backfill shall be taken from a sand and gravel pit (selected by the project officer) excavated uniformly to a depth of 5 feet and shall be placed in 6-inch lifts in a manner that will not cause segregation of the backfill material. All backfill and fill shall be compacted to at least 90-percent maximum density at optimum moisture content by means of pneumatic or other mechanical compaction equipment. All backfill placed within 2 feet of the structure shall be free from rocks, boulders, and clods larger than 2 inches at the greatest dimension, and vegetable matter and other debris, otherwise the backfill material may be used as obtained from the pit. The backfill shall be placed in alternate layers from both sides of the structures maintaining as nearly as practicable a uniform height of backfill at all times. In no case should the backfill on one side be carried more than 12 inches higher than on the opposite side. The moisture content and density of the soil will be determined by Project 3.8. If it is determined that moisture must be added to the existing stockpiled material, the methods proposed to be used by the contractor for adding the water, mixing, etc. shall be approved by the project officer prior to the start of backfilling operations. In any case, all processing required to obtain the specified water content shall be accomplished before the material is placed around or over the structure. The earth fill shall be maintained within a tolerance of plus or minus $\frac{1}{10}$ th of a foot on the flat top of the cover; all other areas shall be maintained with a tolerance of plus or minus 6 inches. In all cases the earth fill profile shall be similar in shape to the profile indicated on the construction drawings. Prior to backfilling, the contractor shall ascertain that the end bulkheads are plumb and that all slack is removed from the tie rods. Backfilling shall not be started until the contractor is certain that once started, a day-to-day sequence of backfilling operations can be effected.

"Earth-moving equipment may be used according to standard practices, except that no heavy equipment will be permitted to operate over the crown of the structures and/or their component parts, or nearer than 5 feet to the outboard portion of the sides of the structure, or 9 feet to the ends of the structure. Pneumatic hand tampers may be used for compacting the backfill immediately adjacent to the surfaces of the structures.

"SECTION 3 CONCRETE CONSTRUCTION

"General requirements. Concrete may be ready mixed. All concrete shall be Class E-1 (3,000 psi).

"Setting miscellaneous material. When practicable, all anchors, and bolts including those for equipment bases, pipe sleeves, angle frames or edgings, and all other material in connec-

tion with concrete shall be placed and secured in position when the concrete is placed. Anchors and anchor bolts shall be plumbed carefully and set accurately and shall be held in position rigidly to prevent displacement during the placing of the concrete.

"Cleavage joints, (indicated as P.E.J) shall be provided between vertical surfaces and concrete slabs laid on the earth; they shall be not less than $\frac{1}{2}$ -inch wide and shall extend the full depth of the slab. Cleavage joints shall be filled with premolded joint filler.

"Concrete deadmen shall be provided at each end of the building for strengthening of the end walls.

"Finishes for floors and other wearing surfaces. Floor slabs, pads and all other wearing surfaces shall be given a float finish.

"SECTION 4 PREFABRICATED METAL BUILDINGS

"General requirements. The prefabricated arch-type corrugated sheet steel buildings that are furnished by the Government shall be modified and erected completely by the contractor at the locations directed. Erection shall be in accordance with the manufacturers recommendations, except that a new corrugated sheet steel front wall shall be substituted for the flat sheet steel bulkhead furnished with the buildings. The contractor shall provide all bracing, strutting, planking, platforms, scaffolding and lifting devices required or necessary for erection. All laps in corrugated metal work shall be coated with a $\frac{1}{16}$ th-inch thickness of an approved bituminous mastic the entire width of the contact surface of the laps. After the work has been assembled, a 6-inch width of mastic not less than $\frac{1}{8}$ th inch thick shall be applied over all joints, into this shall be carefully imbedded a 6-inch width of glass joint tape.

"New walls. Each building shall have a new front wall of corrugated sheet steel provided. Structures 'a' and 'c' shall also have a new rear wall furnished. The new front wall for Structure 'b' shall be of 8-gage metal. The new front wall and rear wall for Structures 'a' and 'c' shall be of 3-gage metal. Framework for the new wall shall consist of structural steel angle and channel shapes, clips, plates, and all necessary fastenings. Welding shall conform to the requirements of the American Welding Society. The new corrugated sheets shall be cut and fitted accurately and neatly to the contour of the end of the building and shall be fastened in place securely; fasteners shall be of the same type used for the rear wall. Openings shall be cut and fitted accurately and neatly.

"Corrugated pipe ingress shaft and tunnel. The ingress tunnel and pipe shaft shall be of corrugated steel culvert pipe conforming to the applicable requirements for Type I, Class II of Federal Specification QQ-C-806a, except that zinc-coating will not be required. Metal shall weigh not less than 6.875 psf before corrugating. Interconnections of the culvert pipe to form the shaft and tunnel and the connection of the tunnel to the building wall shall be welded. Openings shall be cut accurately and fitted neatly.

"Fill at the top of concrete wall shall be fibrous glass wool. The fibrous glass wool shall be packed into spaces; and the continuous metal plate indicated shall be provided on the partitions.

"SECTION 5 MISCELLANEOUS METAL WORK

"General requirements. Steel and iron shall be standard, well finished, structural shapes, or bar steel or bar iron. Cast iron shall be soft, tough, gray iron; castings shall have sharp corners and edges, and shall be clean, smooth, and true to pattern. Welding shall be done in a manner that will prevent permanent buckling.

"Workmanship and finish shall be equal to the best practice of modern shops for the respective work. Exposed surfaces shall have smooth finish and sharp, well-defined lines and arrises. Sections shall be well formed to shape and size with sharp lines and angles; curved work shall be sprung evenly to curves. All necessary rabbets, lugs, and brackets shall be provided so that the work can be assembled in a neat and substantial manner. Holes for bolts and screws shall be drilled. Fastenings shall be concealed where practicable. Thicknesses of metal and details of assembly and supports shall provide ample strength and stiffness. Joints exposed to the weather shall be formed to exclude water. Work shall be fabricated and installed in a manner

that will provide for expansion and contraction, prevent the shearing of bolts, screws, and other fastenings; insure rigidity; and will provide close fitting of sections.

"Anchors and bolts shall be provided where indicated and where necessary for fastening work in place; they shall be embedded in the concrete as the work progresses and shall be spaced not more than 2 feet on centers, unless indicated otherwise. Sizes, kinds and spacings of anchors not indicated or specified shall be as necessary for their purposes. Anchors for securing wood door frames shall consist of flat steel bars not less than $\frac{3}{16}$ by $1\frac{1}{4}$ inches with ends bent up about 2 inches and, where practicable, extending not less than 8 inches into the concrete; they shall be spaced not more than 24 inches on centers and secured to the frames with screws.

"Metal ladders shall be of a steel or iron. Uprights shall be $\frac{3}{8}$ by 2 inches and spaced not less than 16 inches apart; they shall be not less than 6 inches from the shaft walls and shall be anchored in place securely. Rungs shall be $\frac{3}{4}$ inch in diameter and spaced 12 inches on centers; the ends of rungs shall be fitted tightly into and secured to the uprights in an approved manner with the exposed ends finished smooth.

"Air intake. The air intake pipe in the roof shall be of 8-inch diameter standard weight black steel pipe. The intake shall be supported on and fastened to angle legs; the legs shall extend not less than 2 feet above the floor slab and shall be fastened to the slab with leg screws through angle clips into expansion shields.

"Corrugated culvert pipe for vent stack shall be of metal weighing not less than 5.625 psf before corrugating and shall conform to the applicable requirements of Specification QQ-C-806a, except that it may be of black or zinc-coated steel.

"Air regulators. Air regulators shall be constructed approximately as indicated; the frames shall be of sheet steel weighing not less than 5.625 psf, and shall form grooved tracks for the vertical sliding hard-pressed fiberboard slides. Wing screws shall be provided through the frames in a manner that will allow the adjustment of the slides in various open positions. Fiberboard shall be of the thicknesses indicated and shall be tempered.

"Metal flashings shall be of black sheet metal weighing not less than 1.25 psf before forming. Flashings shall be installed in an approved and weathertight manner.

"Metal closures of black sheet steel shall be provided at the ends of corrugated pipe tunnels and elsewhere as indicated. Closures, unless indicated otherwise, shall be of metal weighing not less than 6.875 psf before forming. Closures shall be secured to the contiguous construction in a rigid and substantial manner.

"Metal grafting baffles and grating covers for auxiliary Structures 'X' and 'Y' shall be constructed approximately as indicated. The grating shall be fabricated by means of welding and shall fit the openings snugly without loose play and rattle. A $\frac{3}{16}$ -inch-thick steel plate shall be provided over the baffle in the air intake pipe on the roof.

"Ductwork. The sheet metal ductwork connecting the concrete plenum chamber with the building shall be formed from sheet steel weighing not less than 8.125 psf before forming and coating. All joints shall be soldered tight. A steel plate closure $\frac{3}{16}$ inch thick shall be provided at the plenum chamber end of the connecting duct. Metal may be black or zinc-coated.

"Metal sleeves shall be provided where ducts, pipes and conduits pass through exterior walls and interior partitions. Sleeves shall be formed from metal weighing not less than 6.875 psf, before forming. Sleeves shall be set in the proper locations and position and fastened in place rigidly. After the ducts, pipes and conduits are in place the entire depth of the sleeves shall be calked from the interior with shredded lead wool.

"Steel arch ribs. The 6-inch steel I-beam arch rib stiffeners for Structures 'a' and 'c' are not included as a part of Government-furnished material. They shall be provided by the contractor including base plates, anchor bolts, clips, connectors and fastenings.

"SECTION 6 CARPENTRY

"General requirements. Lumber and woodwork shall be protected from the weather. All material for millwork shall be kiln dried. All cutting, framing, and fitting necessary for accommodation of other work shall be provided.

"Framing. Locations, dimensions, or arrangements of framing members not indicated shall be as necessary for their purposes. Spiking, nailing, and bolting shall be done in a substantial manner.

"Interior wallboard finish. The wood frame partitions shall be finished both sides with one layer of $\frac{3}{8}$ -inch gypsum wallboard covered with $\frac{3}{16}$ -inch cement-asbestos board; joints in each layer shall be broken; 'joints in gypsum board shall be filled and taped.' Application shall be in accordance with the manufacturers' recommendations. Ceiling surfaces, where indicated, shall be finished as specified for the wood frame partitions.

"Duckboard walkways shall have 2-by-4-inch wood stringers and 1-inch thick wood plank flooring. Floorings shall be laid $\frac{3}{4}$ inch open.

"Doors shall be of the flush type and of hardwood or softwood. Doors indicated to have air-regulators shall be cut accurately and neatly and reinforced as necessary for installation of the regulators. Each door shall be provided with 2-but: hinges and a wrought steel latch set.

"Weather stripping at the heads and jambs of doors shall be of the bronze spring type; at the bottoms of doors with metal thresholds weather stripping shall be of the type that will engage the extended lip of the threshold.

"Sealing gaskets of polymerized chloroprene shall be provided at the head, jambs, and thresholds of all doors numbered 1.

"SECTION 7 MECHANICAL EQUIPMENT

"Materials and installation. All piping shall be inspected and approved before being buried, covered, or concealed. Pipe, valves, and accessories may be taken from stock, but, if required, the contractor shall submit certificates identifying the material furnished. The contractor shall provide all new fixtures, piping, duct and accessories. Piping systems shall be designed and constructed to adequately compensate for expansion and contraction.

"Sanitary (waste) piping, (underground) shall be extra heavy cast iron bell and spigot pipe and fittings.

"Sanitary (waste) piping and fittings above ground. Pipe shall be zinc-coated standard-weight screw-jointed steel; fittings shall be cast iron recessed-and-banded screw-jointed drainage type. Fittings shall be the long radius type.

"Water piping below and above ground. The cold water piping shall be zinc-coated steel pipe with zinc-coated malleable iron fittings. Hot water piping shall be Type L copper tubing with soldered brass or copper composition fittings using 50-50 lead-tin solder.

"Installation of piping and fittings.

"(a) Cleaning and protection of pipe. Before being placed in position, pipe and fittings shall be cleaned carefully. All pipe shall be maintained in a clean condition.

"(b) Laying of bell and spigot pipe. Piping shall grade preferably $\frac{1}{4}$ in/ft and in no case shall it be graded less than $\frac{1}{8}$ in/ft. Piping shall be laid with bell ends pointing up grade. Spigot ends shall be adjusted in the bells so as to give a uniform space all around and, if any pipe does not allow sufficient space for proper caulking, it shall be replaced by one of proper dimensions. Open end of pipe shall be closed by a watertight cleanout plug. Joints in sanitary pipe and fittings shall be caulked with braided or twisted hemp or oakum of the best commercial grade and shall be made in one pouring and caulked in a manner that will assure tight joints without over-straining the iron of the bells. After caulking, the lead shall be practically flush with the face of the bells. The lead shall contain not less than 99.7 percent pure lead. Cleanouts shall be fitted with ferrules and brass screw plugs. Cleanouts in floors shall extend full size to the floor level fitted with countersunk cap.

"(c) Installation of screw-jointed piping and solder-jointed tubing. All pipe and tubing shall be cut accurately to measurements established by the contractor and shall be worked into place without springing or forcing. Proper provisions shall be made for the expansion and contraction of all pipe and tubing lines. Pipe and fittings shall be free from fins and burrs. Screw joints shall be made with a lubricant applied on the male threads only; threads shall be full cut and not more than three threads on the pipe shall remain exposed. All copper tubing shall be

cut with square ends, and all burrs and fins removed. Tubing shall be handled and protected carefully and all tubing cut, dented, or otherwise damaged shall be replaced with new tubing. End of tubing and fittings shall be cleaned and inserted in the fittings to their full depth. Unions shall be provided where required for ready disconnection. On ferrous pipe, unions shall be 150 pounds steam-working-pressure, zinc-coated, malleable-iron, ground-joint type. On sanitary piping, tucker connections may be used. Pipe and tubing hung from ceilings shall be supported by heavy adjustable wrought-iron or malleable-iron hangers spaced not more than 10 feet apart. All hangers and collars shall be of the sizes suitable for the weight of the pipe and tubing.

"(d) Check valve shall have brass or bronze body with swing check. All surfaces of valves shall have the natural or machined finish produced by the usual commercial manufacturing processes, and shall be free from noticeable imperfections.

"Plumbing fixtures.

"(a) Service sink, shall be one piece cast iron with acid-resisting white enamel on inside and over the rim and back. Rim shall be fully rounded. Space for supply pipes shall be provided behind the back. Sink shall be approximately 24 by 20 inches with sink portion 12 to 14 inches deep and splash back 10 to 12 inches high. Faucets shall consist of combination fitting with exposed body, union inlets, indexed lever style metal handles without hood. The fixture shall be furnished with a trap standard and with concealed metal hanger or wall brackets to suit the style of fixture. Trap standard shall be cast iron P-trap, painted outside and enameled inside with acid-resisting enamel. Trap shall support fixture on floor and be of open pattern without vent, and have brass screw cleanout plug at front below the water surface of the trap. Depth of water seal shall be not less than 2 inches. Inlets shall be not less than 2 inches. Inlets shall be tapped to receive the threaded shank or machine screws of the strainer. Wall outlet connection shall be tapped for 3 inch pipe and shall be adjustable as to height.

"(b) Shower outfit shall consist of a shower head, riser pipe, shower valve assembly or unit, union couplings for supplies, supply pipes to ceiling, and bulkhead supports. Shower drain shall be of heavy cast iron, double drainage pattern, with cast iron seepage pan for embedding in floor construction and with weep holes providing adequate drainage from pan to drain pipe. Perforated or slotted strainer of brass attached to a brass threaded collar for adjustment to varying floor thickness shall be furnished.

"Air duct shall be constructed on heavily zinc-coated sheet steel having a minimum weight of not less than 0.906 psf. Duct shall have open ends and installed as indicated. Duct hangers and supports shall be of steel, and substantial, rigidly braced and of approved design.

"SECTION 8 ELECTRICAL WORK

"Material and workmanship shall conform to the National Electrical Code and the standards of the Underwriters Laboratories, Inc.

"Direct burial cable shall have Type RHW insulation and a polychloroprene sheath.

"Lamps shall be 115-volt incandescent type.

"Safety switches shall be the standard duty type.

"Rubber-covered drop cord shall be Type SV."

A.2.2 Equipment. The plenum for the blast closure valve consisted of a stock test shelter made available to the project and modified at the test site. Modification included provision for 8-inch air-inlet pipe and closure of conduit which were part of the stock shelter.

The 5-kva generators (Navy Yards and Docks Supply No. G-73665) were powered by Willys 4-cylinder gasoline engines. The 15-kva generators (Navy Yards and Docks Supply No. G-73728) were powered by Chrysler Industrial 6-cylinder gasoline engines.

A.3 SOIL-SURVEY PROGRAM

A.3.1 Soil Data. The soil-survey program (Project 3.8) consisted of (1) compaction control

during backfill operations, (2) record sampling during backfill operations, (3) soil tests in WES laboratories, (4) soil tests at NCEL, and (5) determination of water content of backfill before shot. Specifications for backfill are included in Section A.2.1. Sieve analysis, classification, compaction test, and density data of the soil used for backfill are included in Figure A.9. Density and moisture-content measurements utilized for compaction during backfilling operations are included in Table A.1.

Seven days prior to the shot, 18 water-content samples were obtained from depths of 0.5 and 3 feet; 3 days prior to the shot, 12 similar samples were obtained and tested in the field laboratory to determine the rate of change of water content in the backfill. The test results indicated that the change in water content was not significant during the period from 7 to 3 days prior to the shot.

Triaxial shear tests were performed by NCEL on one sample each from fill over Structures 3.3a and 3.3c. The tests performed, used 2.8-inch-diameter specimens which passed a $\frac{1}{2}$ -inch sieve. The fractions of materials passing the $\frac{1}{2}$ -inch sieve were 91.9 and 91.8 percent of the samples from fill over Structures 3.3a and 3.3c respectively. The rate of strain was 0.1 in/min. Results are:

Sample	Depth	Position	Water Content	Dry Density	Angle of Internal Friction ϕ	Cohesion
	ft		pct	pct	deg	psi
3.3a	+1.0	Over crown	9.9	115.2	41.0	1.8
3.3c	+1.0	Over crown	10.3	115.4	49.0	1.0

The results of chemical and spectrographic analyses which have been performed by NCEL and the density measurements and moisture-content measurements taken at the site (Project 3.8) are included in Table A.2.

Table A.3 gives the compressibility characteristics of the natural Frenchman Flat soil and of the gravelly silty sand backfill as determined by tests conducted at WES and reported in Reference 22. The gravelly silty sand backfill contained about 15 percent of material retained on the Number 4 sieve. In order to prepare gravelly silty sand specimens for laboratory testing, it was necessary to use a portion of a representative sample passing the Number 4 sieve. Laboratory testing procedures used are described in detail in Reference 22.

Based on limited bearing-capacity tests of the natural soil in the Frenchman Flat area, the ultimate bearing capacity at a 13-foot depth has been estimated to be 4 to 7.5 tons/ft². Additional data on the natural soil and on the gravelly silty sand used for backfill is included in Reference 22.

A.3.2 Backfill Operations. Compaction of backfill for this project was performed in a manner as nearly similar to standard construction practices as practicable. The entire fill was compacted, in order to simulate an actual installation where natural consolidation would compact the material within a period of several months.

The material was excavated from a preselected area to an approximate depth of 5 feet. The soil was removed from the pit using self-propelled scrapers together with loading-pusher Caterpillar tractors, hauled to the site of backfilling in the scrapers, and stockpiled at each structure excavation. During the digging of the backfilling material, water trucks kept the surface of the soil well saturated. An effort was made to keep each scraper load as uniform as possible by scooping soil at angles so that material from the surface, as well as material from a 5-foot depth, was included in each scraper load.

The backfill stockpiles were not processed further except for daily wetting of the surface of each stockpile with a water truck prior to the start of backfilling operations, to prevent excessive surface drying. By placing the backfill material in 6- to 8-inch lifts with a clamshell and

utilizing the compaction methods described in the next paragraph, compaction requirements (90 percent maximum density at optimum moisture content) were satisfied.

Up to a point approximately 6 feet directly above the spring line, 6-inch pneumatic tampers were used in a pattern illustrated in Figure A.10. From the 6-foot point to the completion of backfill, gasoline-engine-driven vibrating rollers were used; four passes over each area provided ample compaction effort. The compactors are shown in Figure A.11. At the extreme side edges of the earth mound above original grade, a D-8 Caterpillar tractor (bearing pressures approximately 10 psi) was used for compaction by making four passes over each area.

TABLE A.1 SAND DENSITY TESTS

Date of Sample	Structure and Station	Depth above (+) or below (-) Ground Surface	Location	Water Content W _c pct	Dry Density γ _d pcf
1957		ft			
16 May	3.3a (9019.01)	-12	Leeward	11.4	109.2
18 May		-6	Leeward	8.5	111.4
21 May		+1	Over center	9.9	115.2
22 May		+4	Over center	9.4	115.1
			Average	9.8	112.7
7 May	3.3b (9019.03)	-11	Leeward	9.0	109.0
9 May		-7.5	Blast side	8.2	110.0
9 May		-7.5	Leeward	8.1	118.2
13 May		-6	Blast side	9.5	114.4
13 May		-5	Leeward	9.5*	97.7*
16 May		+1	Over center	9.3	119.8
18 May	+3.5	Over center	7.2	112.7	
			Average	8.7	111.7
23 May	3.3c (9019.02)	-12	Leeward	11.1	115.9
25 May		-6	Leeward	8.7	117.1
29 May		+1	Over center	10.3	115.4
30 May		+3.5	Over center	8.1	113.5
			Average	9.6	115.5

* If discarded, average for 3.3b (9019.03) = W_c = 8.6 and γ_d = 113.9

TABLE A.2 CHEMICAL AND SPECTROGRAPHIC ANALYSIS OF BACKFILL

Structure	Depth Above Grade*	Density pcf	Water Content, pct			Elemental Composition, pct									
			At Backfill	D-7	D-3	Si	Al	Mg	Fe	Ti	Na	Ca	Mn	Cu	B
3.3a	+1.0	115.2	9.9	8.4	10.8	12.0	13.8	8.0	4.4	0.9	A	A	B	C	C
3.3a	+4.0	115.1	9.4	6.4	7.3	12.5	12.4	9.0	4.6	1.2	A	A	B	C	C
3.3c	+1.0	115.4	10.3	9.5	10.3	13.0	12.0	3.0	4.0	0.5	A	A	B	C	C
3.3c	+3.5	113.5	8.1	7.0	7.1	10.5	13.6	9.0	5.6	0.7	A	A	B	C	C
	Accuracy ± 1.0 pct		Quantities shown are accurate to nearest 0.1 pct			Accuracy ± 10 pct for Si, Al, Mg, Fe, and Ti					A = 1 to 10 pct B = 0.01 to 0.1 pct C = 0.001 to 0.1 pct				

* Position over center.

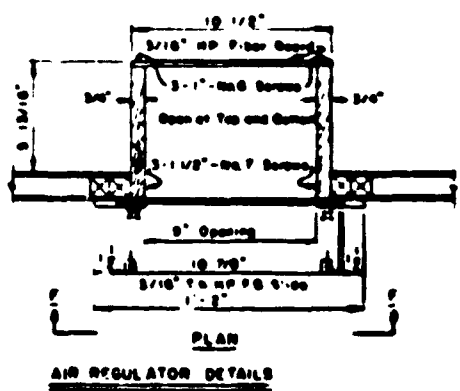
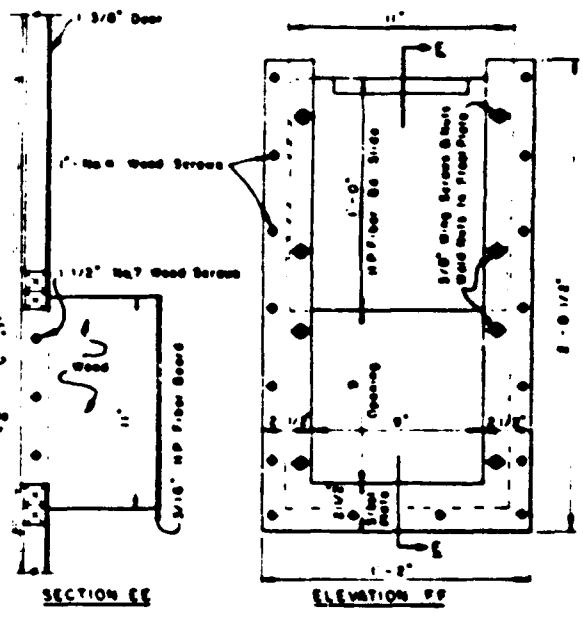
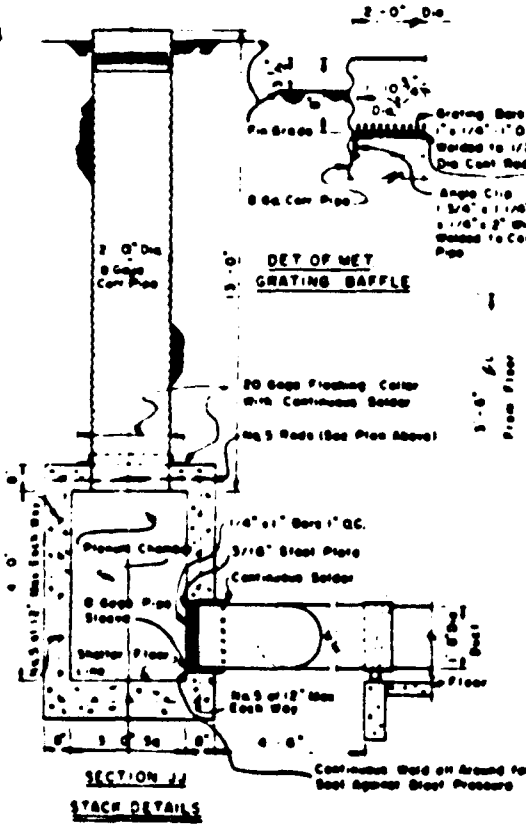
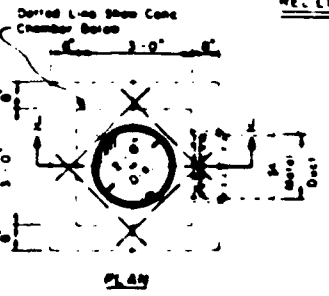
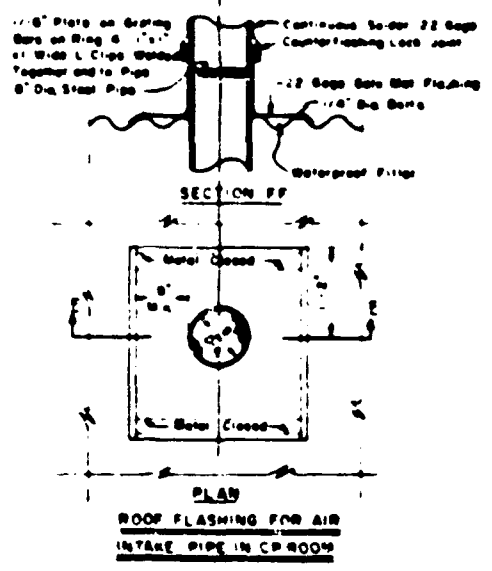
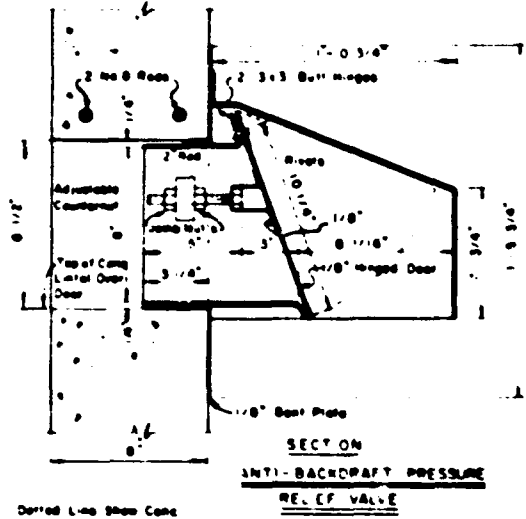

Figure A.2 Ventilation details.

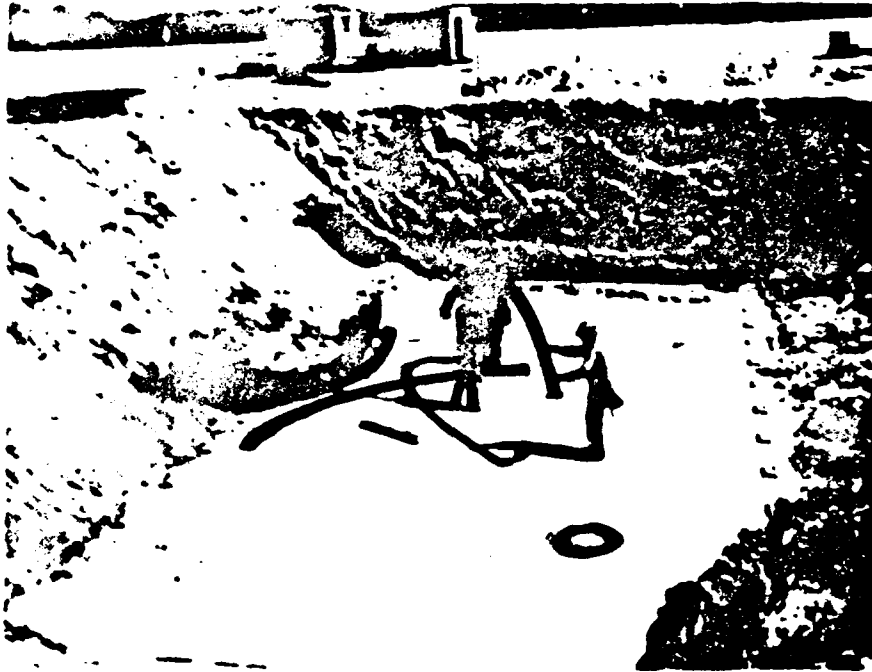

Figure A.7 Assembly of steel ribs, Structure 3.3c.

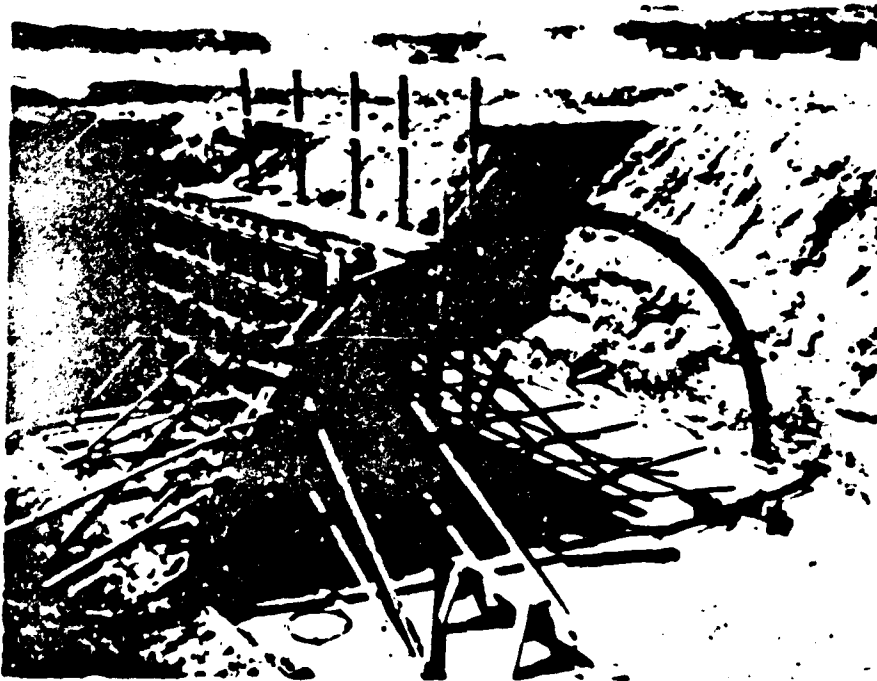

Figure A.8 Form work for interior concrete bulkhead, Structure 3.3c.

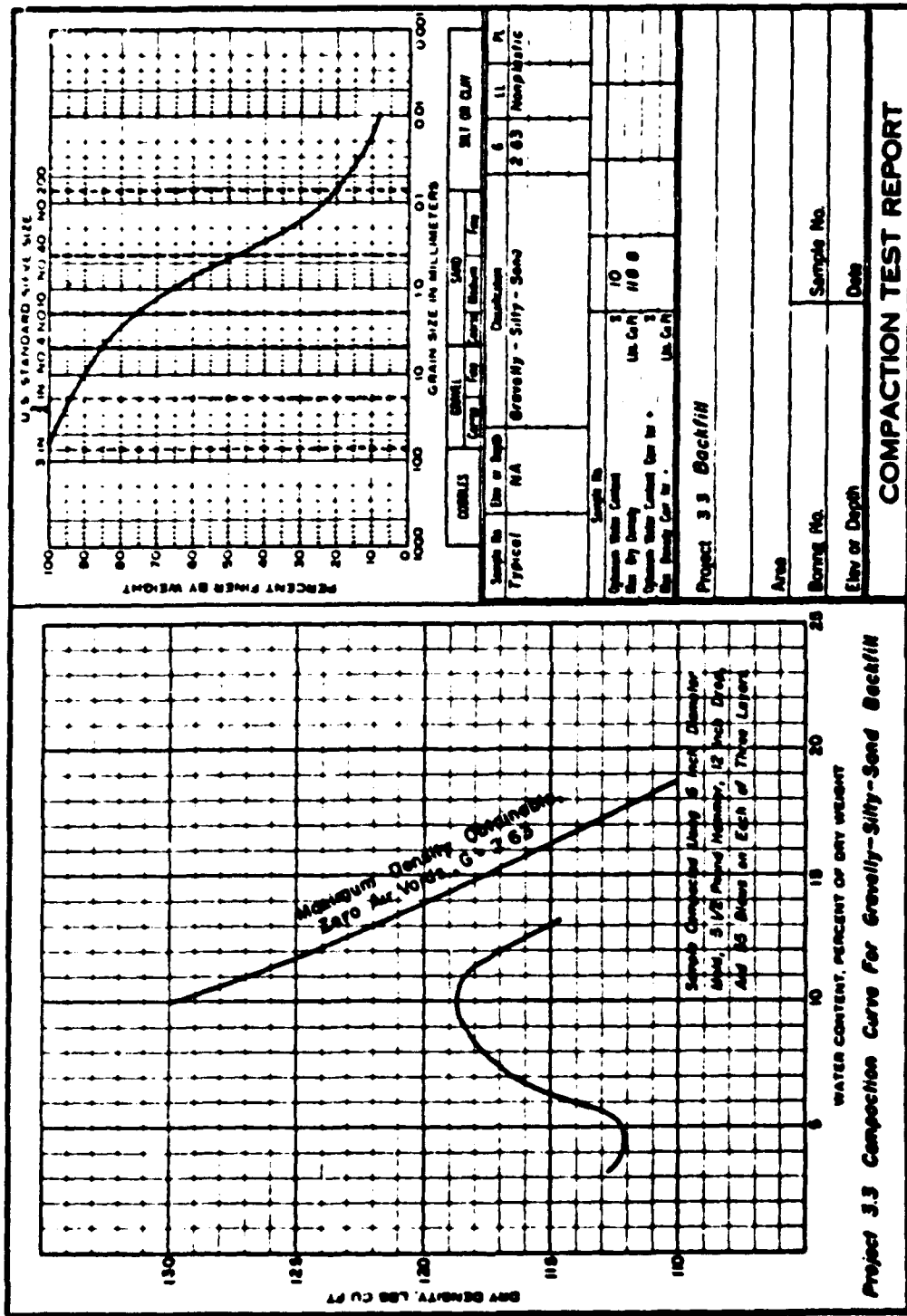

Figure A.9 Soil-survey compaction test report.

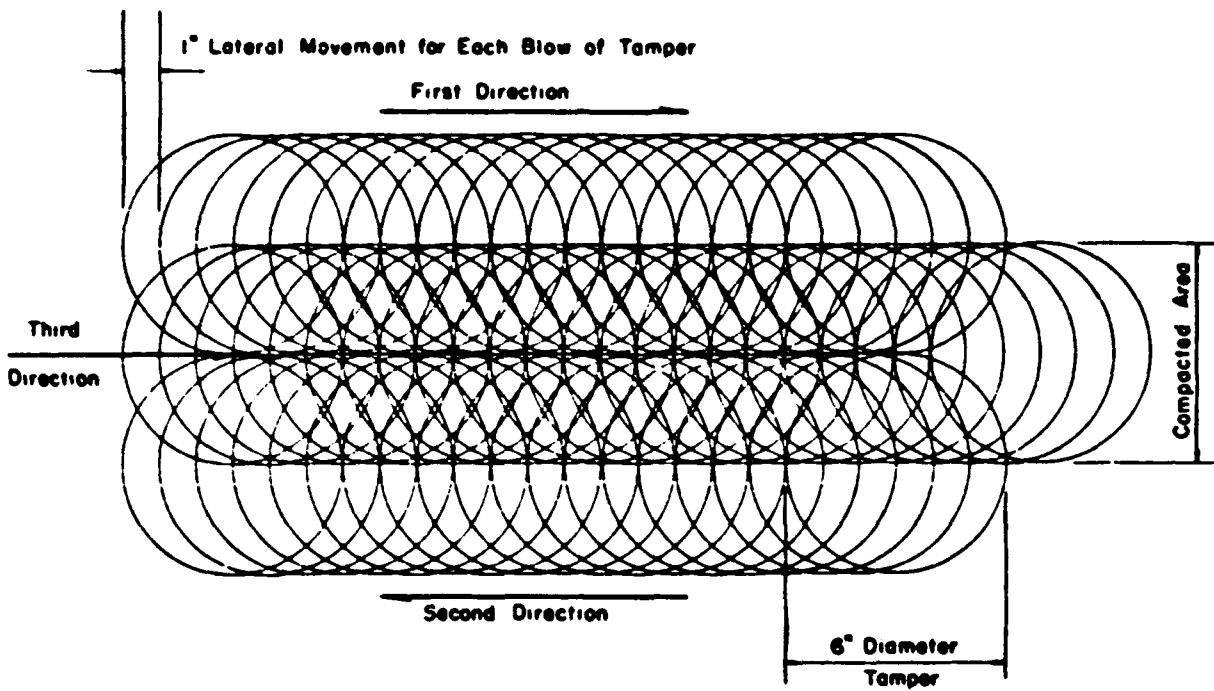

Figure A.10 Tamper compaction pattern.

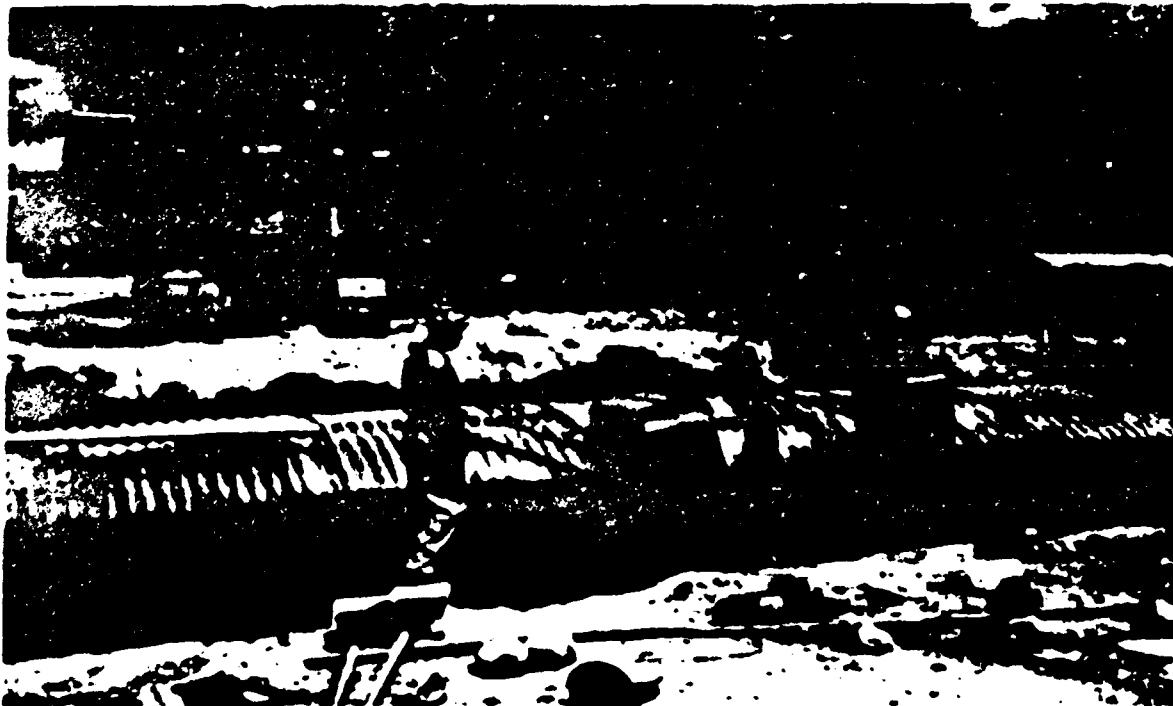

Figure A.11 Compacting backfill with vibrating roller.

Appendix B

STRUCTURE INSTRUMENTATION

B.1 DEFLECTION GAGE

The scratch-type deflection gage was utilized to determine maximum and residual dynamic deflections. The Model P-3.3, illustrated in Figures B.1 and B.2, consisted of a scribing assembly, one scratch plate, and attaching hardware. The scribing assembly and attaching hardware, shown in Figure B.3, was either attached to the curved I-beam with bolts or mounted directly on one of the bolts connecting the corrugated-plate structural sections. The scratch plate, made of 16-gage aluminum sheets, was attached with screws to a sheet of $\frac{1}{4}$ -inch plywood mounted to a supporting wood framework solidly anchored to the floor slab. The plate was coated with conventional bluing compound used by machinists; thus, the scratches showed as aluminum colored. An overall rear view of the final assembly is shown in Figure B.4.

Scratch-gage results are included in Chapter 2. By taking into account the final position of the spring line of the arch relative to the floor slab, a correction has been made to provide an absolute-type value of residual deflections of the corrugated steel plates and arch ribs.

It was concluded that the Model P-3.3 deflection gage performed satisfactorily and provided deflection patterns of sufficient accuracy, warranted by the requirements placed on such instrumentation.

B.2 SELF-RECORDING PRESSURE-TIME GAGE

The recording mechanism for each pressure-time (p-t) gage was enclosed in a heavy, airtight case, the top of which acted as a baffle plate. Holes in the baffle plate allowed initiation and pressure intake.

The sensing element was basically a chamber formed by welding together two diaphragms at their edges, each impressed with a series of connective corrugations. A stylus, consisting of an osmium-tipped phonograph needle mounted on a spring arm, was attached to the element. When pressure was transmitted inside the element, the element expanded. This expansion, which is proportional to the amount of pressure, was scratched on a silvered glass disk by the stylus. The glass disk was mounted on a turntable and was driven by a carefully governed motor in order to record the scratch of the stylus versus time.

Calibration of the pressure capsules was performed by the manufacturer. The calibrations were plotted using a Leeds-Northrup X-Y recorder. The output of a Statham strain-gage-type pressure transducer was fed through amplifiers to the pen (X-axis) of the recorder. Capsule deflection was measured by a micrometer head equipped with a mill detector and servo system operating a slide-wire potentiometer which, in turn, controlled the chart drive (or Y-axis). The resulting presentation gave a plot of capsule deflection as a function of applied pressure.

The p-t gage is shown in Figure B.5. Actual installation of the gage is shown in a ground baffle for overpressure measurements (Figure B.6) and inside the plenum chamber for the blast-closure-valve-protected side pressure (Figure B.7).

The self-recording measurements observed on the ground surface were:

Structure	Station	Peak Overpressure psi	Arrival Time sec	Positive Duration sec	Quality of Record
3.3a	9019.01	101	—	—	Peak only
3.3b	9019.03	60	0.121	0.361	See Figure B.8
3.3c	9019.02	75*	—	—	Poor
3.3cp	9060	-0.3 † -1.2	0.410	0.345	Good

* Gage mounted on top of earth berm. † Gage mounted in plenum.

The pressure values used in Table 2.4 were obtained by utilizing a combination of the data just described and data obtained from gages at similar distances from ground zero. In all cases, the tabulated values are within 10 percent of the preliminary composite overpressure curve for Shot Priscilla.

B.3 PEAK-PRESSURE GAGE

The peak-pressure gage utilized a pressure capsule similar to that used in the pressure-time gage, except that the recording blank was held stationary. The recording blank, a silvered glass rectangle, was put in place under the capsule stylus. When activated by pressure, the stylus recorded the maximum positive and negative deflections of the pressure capsule.

This capsule was calibrated by the manufacturer similarly to the p-t gage. Figure B.9 shows the installation of a peak-pressure gage.

The peak measurements observed were:

Structure	Station	Peak Pressure psi
3.3a	9019.01	2.7
3.3b	9019.03	1.0
3.3c	9019.02	0

The reliability of the peak-pressure values is questionable, as has been discussed in Section 2.4.1. It is concluded that a self-recording pressure-time gage would have provided a more accurate and reliable record.

B.4 DYNAMIC ACCELEROMETERS

B.4.1 Electronic Accelerometer. Electronic-dynamic acceleration-versus-time measurements were made with Wiancko Type 3AAT accelerometers. The sensing element consisted of an armature bonded at its center to the vertex of a V-shaped spring member and held in close proximity to an E-coil. A weight was attached to one end of the armature so that an acceleration in a direction normal to the armature caused it to rotate about the vertex of the spring.

The E-coil consisted of two windings wound on the extreme legs of the E-shaped magnetic core. As the armature rotated, it decreased the reluctance of the magnetic path composed of the armature, the center leg, and one extreme leg of the E and increased the reluctance of the other, similar path.

The electronic accelerometers were given static calibration on a spin table accelerometer before installation (Figure B.10). The spin table was a disk that was rotated at a speed determined accurately by an electronic tachometer. Each accelerometer was mounted on the disk with its sensitive direction parallel to the radius of the disk. Connections to the recorder cable were made through slip rings. An accurate knowledge of the distance of the accelerometer sens-

ing element from the center of the disk and the rotational velocity of the disk were used to find the radial acceleration produced in the sensing element. The installation of the gage on the concrete floor is shown in Figure B.11.

The results of the electronic-dynamic-acceleration measurements of the floor slabs were:

Structure	Station	Value	Remarks
g			
3.3a	9019.01	< 3.0	No apparent value, good record
3.3b	9019.03	< 3.0	No apparent value, good record
3.3c	9019.02	< 3.0	No apparent value, good record

It was concluded that, because of a good electronic record with no apparent values on all gages, a value of less than 3 g had been observed. The accelerometers utilized were of 0-to-100 g range calibrated to 50 g. A small-range gage would have given a more significant record, had it been known that accelerations of such small magnitudes would have been experienced.

B.4.2 Self-Recording Accelerometers. The self-recording accelerometer utilized an element similar to that used on the peak accelerometer. To obtain acceleration versus time, the recording disk was rotated. The installation of the gage is shown to the right in Figure B.12.

The self-recording dynamic accelerometer readings observed were:

Structure	Station	Positions	Values	Remarks
g				
3.3a	9019.01	Floor slab	< (+30.0)	Questionable record
3.3c	9019.02	Floor slab	(+15 to +30)	Questionable record

The self-recording accelerometer values were extremely different from similar measurements of the electronic accelerometers. Because the electronic records were considered good and the self-recording records were extremely questionable, the electronic values have been considered more valid and consequently have been utilized for discussion.

3.5 PEAK ACCELEROMETER

The peak accelerometer was basically the same as the peak-pressure gage (Section B.3). Instead of a pressure-sensing capsule, an accelerometer element was utilized. The element consisted of a cantilever beam with a weight attached to its free end. A spring arm attached to the weight held a stylus which scratched a record on the recording blank when the element was activated. The cantilever beam was shaped to prevent oscillations in any direction except that desired.

The accelerometer elements were calibrated by clamping them in a support similar to the one in the gage. This support was then placed on a calibrated drop table, to be subjected to transient acceleration. The drop table consisted of a heavy metal plate which was raised to a predetermined height and then allowed to fall freely. The fall was terminated by a box of sand into which the plate fell flat. The accelerations produced when the plate was stopped were accurately reproducible and, by means of a standard accelerometer, have been related to the height from which the plate was released. A peak accelerometer attached to the crown of the metal structure is shown in Figure B.13.

One peak-acceleration gage was used to measure vertical component of the crown of unstrengthened Structure 3.3b. The value observed was -15 to -30 g; however the record was somewhat questionable. It was concluded that the electronic dynamic accelerometer would have provided a more valid measurement.

B.6 DUST COLLECTORS

Two somewhat-similar types of dust collectors were utilized. The first, which was taped to the floor of each shelter, consisted of an ordinary glass microscopic slide, 1 inch of which was covered with transparent scratch tape, sticky side up. The second was a sticky-tray fallout collector; to provide rigidity, a $\frac{1}{16}$ -inch-thick plate of galvanized sheet metal ($9\frac{1}{2}$ by $10\frac{1}{2}$ inches) was employed as the tray. Transparent, but sticky, paper was fastened on the tray with masking tape. The top of the sticky tray (8 by 9 inches) was protected by two rectangular pieces of paper which ordinarily were stripped off just before exposure to the collector. Upon installation of each plate, one of the protective papers was removed and the uncovered side of the collector was marked C for control. During final preparations for the shot, (D-2 days), the other protective paper was removed, thus exposing the other side of the collector marked E for experiment. The two types of dust collectors are shown installed in Structure 3.3c in Figure B.14.

The control slide of the fallout collector collected preshot and postshot dust, while the experimental side collected predominantly postshot dust.

Recovery of trays and slides was accomplished upon initial postshot entry of the structure (D+3 days). The top of the microscopic slides were covered with a piece of transparent scotch tape, and the fallout trays, after being pried loose from the floor, were placed face to face, care being taken to oppose the control side of one collector to the control side of the other taken from the same shelter. These measures served to protect each of the dust collectors from contamination after removal from the several structures.

After recovery, the two opposing sheets of the transparent, sticky paper were stripped from the fallout trays. The sticky paper was successful in trapping debris varying from microscopic particles of dust to small aggregates of dirt.

Each microscopic slide was contaminated with dirt and was usable for subsequent microscopic studies. The results of this final analysis will be reported by Operation Plumbbob Project 33.5.

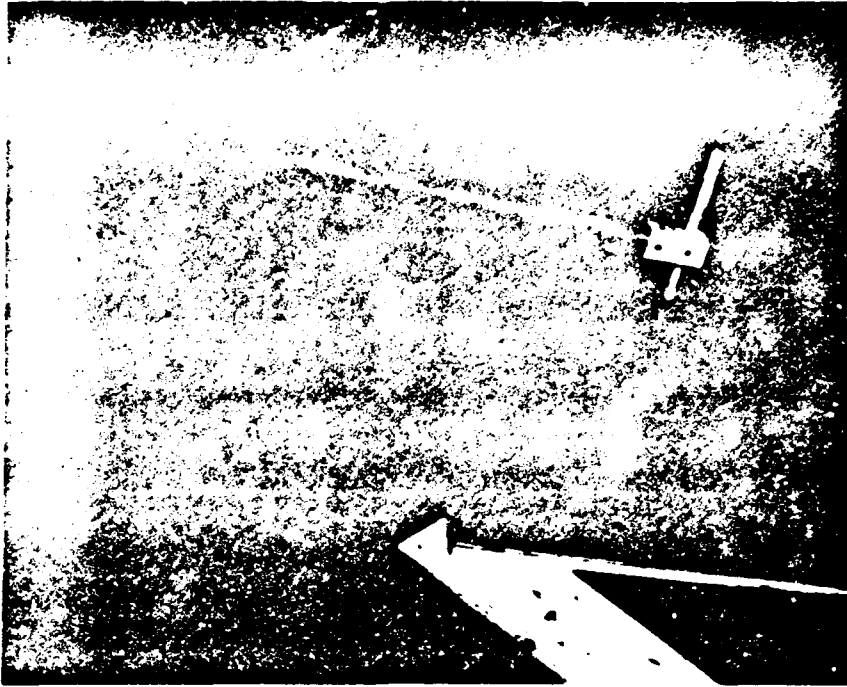

Figure B.1 Scratch-type deflection gage attached to arch rib.



Figure B.2 Scratch-type deflection gage attached to corrugated-steel plate.

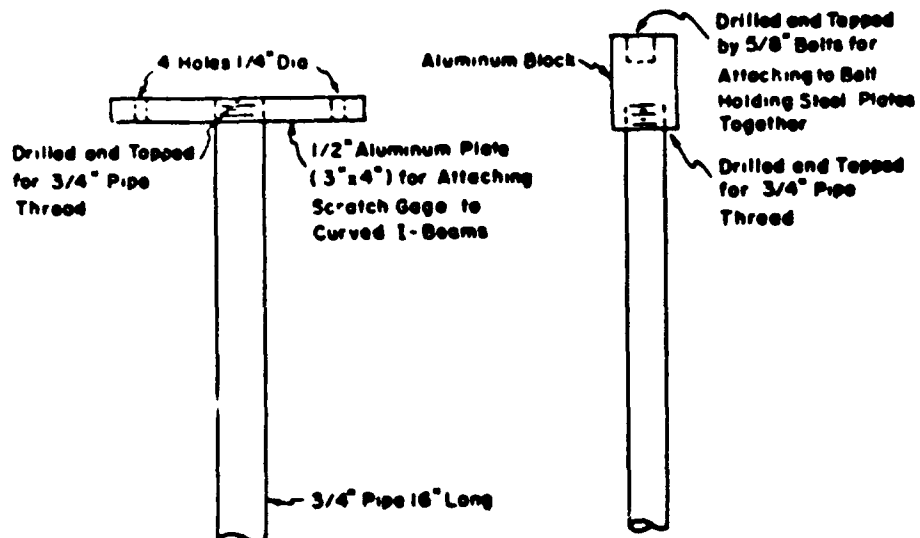

Figure B.3 Model P-3.3 scratch gage.



Figure B.4 Scratch-gage platform (rear view).

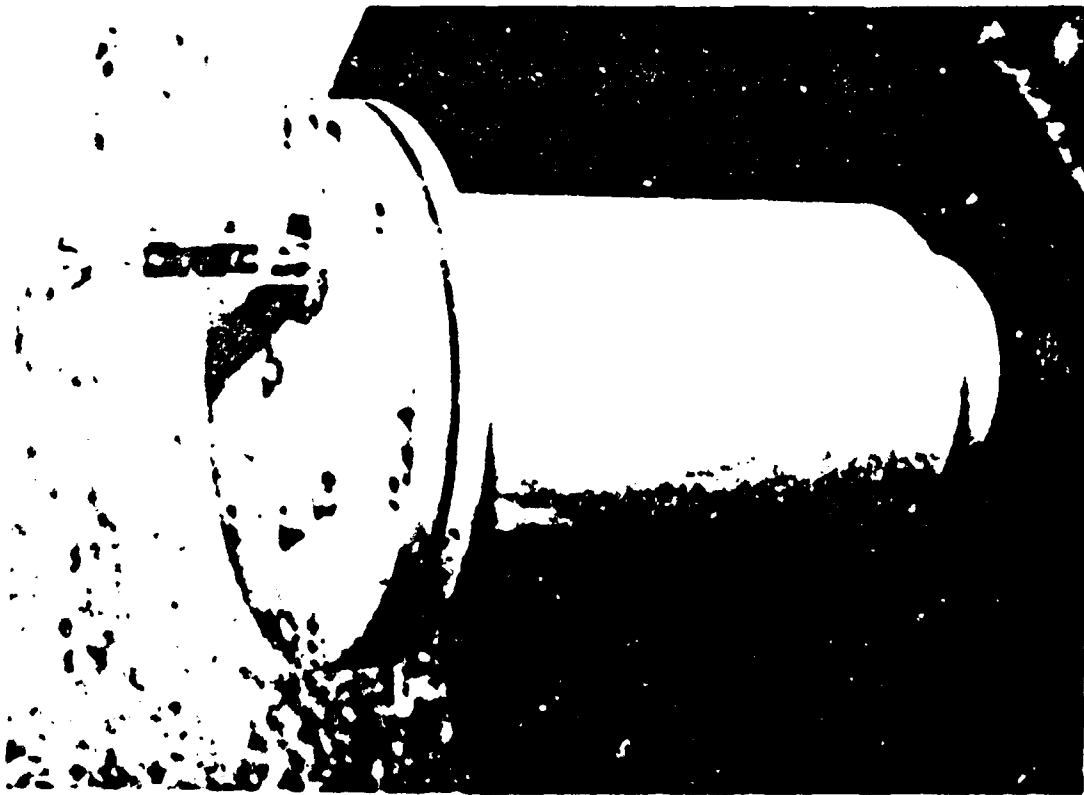

Figure B.5 Self-recording pressure-time gage.

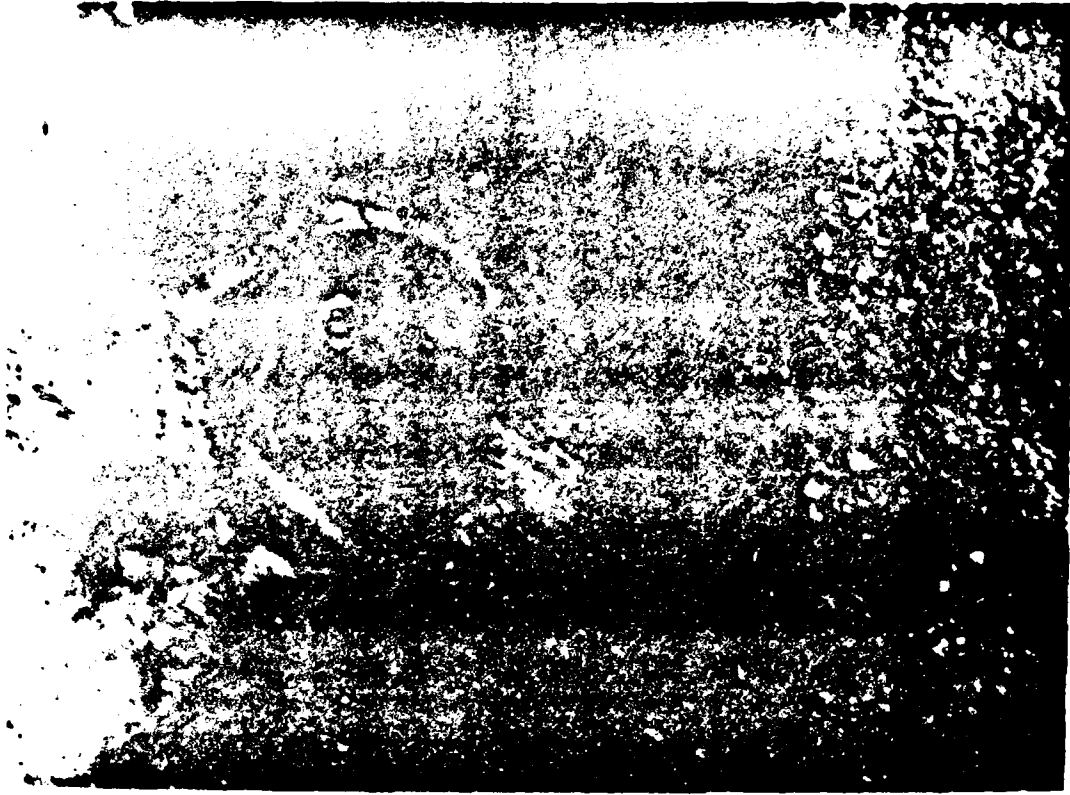

Figure B.6 Self-recording p-t gage mounted in concrete base.



Figure B.7 Self-recording pressure-time gage mounted inside blast closure valve plenum.

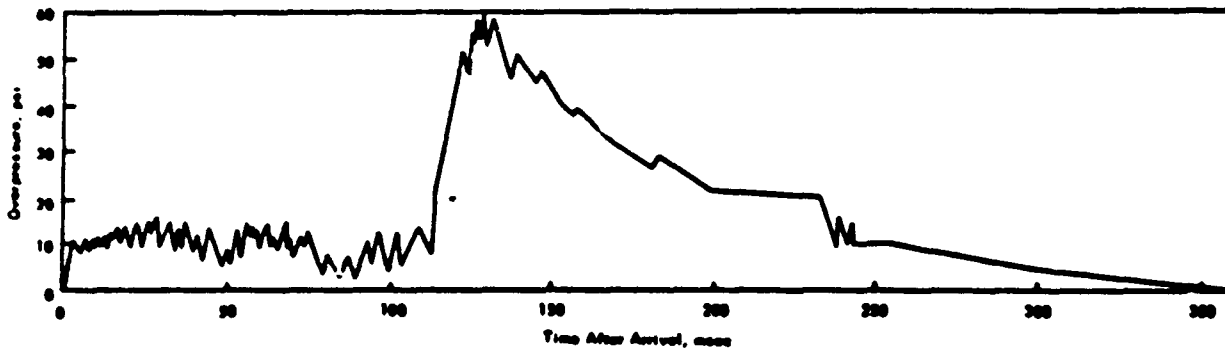

Figure B.8 Recorded overpressure versus time on ground surface at Structure 3.3b.

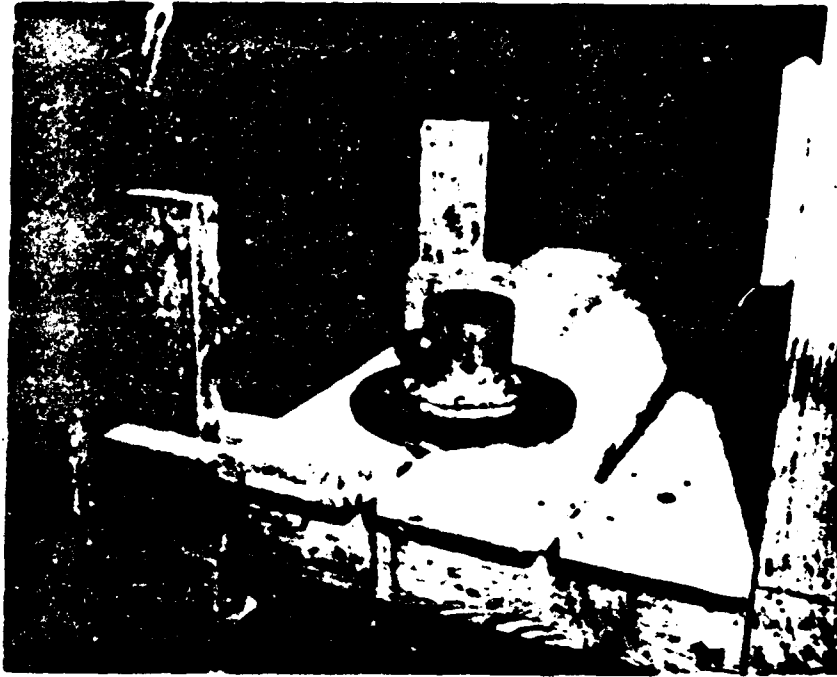

Figure B.9 Peak-pressure gage.



Figure B.10 Calibration of electronic accelerometers.



Figure B.11 Electronic accelerometer in place.

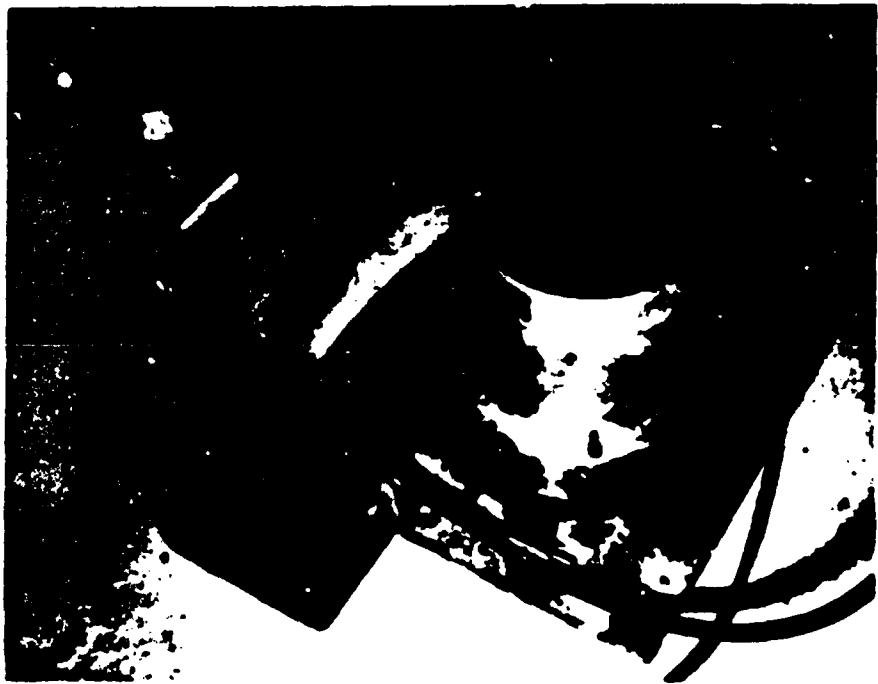

Figure B.12 Self-recording accelerometer (right).



Figure B.13 Peak accelerometer attached to crown of structure.



Figure B.14 Dust collector.

Appendix C

RADIATION INSTRUMENTATION

This appendix was prepared by Project 2.4, Radiological Division, U. S. Army Chemical Warfare Laboratories; Robert C. Tompkins, Project Officer.

C.1 BACKGROUND AND THEORY

Tests prior to Operation Teapot have shown that below-grade shelters give 75 percent better gamma shielding than those shelters that are partially above grade (Reference 23). Teapot data illustrated that completely below grade shelters with 4 feet of radial earth cover gave an inside-to-outside gamma dose ratio (designated herein as a gamma transmission factor) as low as 1.2×10^{-4} and a neutron transmission factor of 1.5×10^{-6} for the high-energy neutron flux, which would be detected by sulfur-threshold detectors (Reference 24). Detector stations nearer to the entranceways of the structures indicated much higher transmission factors, and therefore received higher radiation dosages.

The shelters to be instrumented for radiation measurements at Operation Plumbbob were all underground. For this reason, the Teapot results in the below-grade Structures UK-3.8a, UK-3.8b, UK-3.8c, and UK-3.7 were particularly useful in predicting expected shielding by the shelters at Operation Plumbbob (Reference 24). These results were augmented by empirical relations for neutron and gamma radiation passing through hollow cylinders as given in Reference 25.

In the case of the Plumbbob 3.3 structures, it was generally predicted that they would have lower transmission factors than the Teapot below-grade structures, because the entranceways were farther removed from the structures proper. Within the shelters, a consideration of the slant thickness, which is the line-of-sight cover, indicated that the greater dosages were to be expected in those portions of the shelter more distant from ground zero. Higher transmission factors were expected in the entrance passages, because the steel cover is relatively transparent to high-energy neutrons. In 3.3c, the completely equipped structure, it appeared that the elbow in the ventilation system would adequately prevent scattering of neutron or gamma radiation through the ventilator. However, it seemed possible that the removal of mass might increase the gamma and neutron doses from direct radiation in the immediate neighborhood of the ventilation pipes. This increase was not expected to exceed a factor of 10 (Reference 24).

C.2 DESCRIPTION OF INSTRUMENTATION

C.2.1 Gamma Film Packets. Gamma dose was measured with the National Bureau of Standards—Evans Signal Laboratory (NBS-ESL) film packets (References 26, 27, and 28). In the exposure range from 1 to 50,000 r and in the energy range from 115 kev to 10 Mev, the accuracy of the dosimeter is considered to be within ± 20 percent. The net photographic response is expected to be approximately energy independent. This is achieved by modifying the bare-emulsion energy response, which has peaks near the K-shell photoelectric absorption edges of silver and bromine, by placing the entire emulsion in a 8.25-mm-thick bakelite case covered with 1.07 mm of tin and 0.3 mm of lead and surrounded by a $\frac{1}{8}$ -inch lead strip over the open edges. The entire arrangement is placed in a plastic cigarette case.

Although the angular dependence is negligible when the gamma film packet is exposed to higher

energy radiation, it is important for lower energies. An interpretation of the results obtained in Reference 27 indicates that, for radiation isotropically incident on the packet, the dose value is about 5.5 percent lower for 1.2-Mev radiation than that obtained by an instrument having no angular dependence, about 32 percent lower for 0.20-Mev radiation, and about 45 percent lower for 0.11-Mev radiation. Although the film packets may show only ± 20 percent error in normal radiation fields, some consideration should be given to the fact that, in a relatively isotropic and degraded energy field such as might exist in structures with many feet of earth cover, the film packets may indicate low values.

C.2.2 Chemical Dosimeters. The chemical dosimeters utilized for instrumenting the structures were supplied by the United States Air Force School of Aviation Medicine (SAM).

The SAM chemical dosimeters include two main types of chemical systems. One system is hydrogen-free, and the other has a high hydrogen content. The latter system is essentially water-equivalent in its response. The high-hydrogen-content dosimeters respond to all the gamma rays, fast neutrons, and thermal neutrons, whereas the hydrogen-free dosimeters respond only to the coexistent gamma rays and thermal neutrons (Reference 29). Both systems are based on the same principle: acid formed from the irradiation of chlorinated hydrocarbon is a linear function of radiation dose throughout a broad range (25 to 100,000) (References 29 through 32). Neutron calibration of these systems is described in Reference 33.

The hydrogen-free dosimeters were furnished by SAM in the following prepared ranges: 0.5 to 5, 2 to 20, 5 to 200, 100 to 500, 400 to 2,000, 1,600 to 3,000 and 2,000 to 18,000 rep. The high-hydrogen dosimeters utilized were furnished in the following prepared ranges: 10 to 200, 50 to 500, and 100 to 1,000 rep.

All of the dosimeters, if exposed within their prepared ranges, were evaluated spectrophotometrically or visually by observation of the color changes in the indicator dye from red (pH 6.0 or above) to yellow (pH 5.6 or below). Because these color changes are a function of the dose, exposure doses were estimated by color comparison with irradiated controls. The amount of acid formed, hence the amount of absorbed dose, in overexposed dosimeter (pH 5.6 or below), was evaluated by titration with standardized 0.001 N sodium hydroxide. Division of the amount of acid produced in an unknown exposure by the calibration data for the sensitivity of the system to Co^{60} gamma radiation (namely the amount of acid produced per milliliter of chlorinated hydrocarbon for each roentgen absorbed) yielded the gamma dose in roentgens.

The measurement of the neutron dose with the high-hydrogen-content dosimeter was accomplished by evaluation of the amount of stable acid produced in a mixed radiation field by one of the above techniques. Because the water-equivalent, high-hydrogen-content dosimeter is X- and gamma-ray energy independent and has a known neutron response, the total acid production can be considered as a combined function of the neutron and gamma radiations. Subtraction of the gamma-produced acids as measured by the fast neutron insensitive chemical dosimeter systems (Reference 30) left a given quantity of acid produced by the neutrons. Division of this neutron-produced acid by the acid yield per rep yielded a neutron dose in .srms of reps.

Gamma measurements in the presence of neutrons were accomplished by using the hydrogen-free dosimeters. Because all chemical dosimeters are sensitive to thermal neutrons, the thermal neutron dose was calculated independently from cadmium-gold difference measurements. The data was then corrected by subtraction of 6.7 roentgen equivalents per thermal neutron rep (Reference 32).

C.2.3 Neutron-Threshold Devices. A complete description of the neutron system used for instrumenting the structures can be found in Reference 8. Thermal and epithermal neutron flux was measured with gold foils by the cadmium difference method. This technique yields the flux of neutrons below the cadmium cutoff of about 0.3 ev. Intermediate energy neutrons were measured with a series of three boron-shielded fission-threshold detectors: Pu^{239} (3.7 mev), Np^{237} (0.7 Mev), and U^{235} (1.5 Mev). High-energy neutrons were measured with sulfur detectors having an effective threshold of 3 Mev. The cadmium cutoff and the various energy thresholds are

not clearly defined points. For this reason, neutron fluxes in this report will be identified with detectors rather than with energy ranges.

The accuracy of these detectors is approximately ± 15 percent for doses greater than 25 rep. Measurements are unreliable below 25 rep and cannot be made below 5 rep. The detectors were calibrated and read by Project 2.3.

C.3 INSTRUMENTATION LAYOUT

The objective of the radiation instrumentation was to determine the effectiveness of the buried structures for providing radiation protection. Accordingly, the structures were instrumented to measure the gamma and neutron dose that would be received at a nominal height of 3 feet above the floor of the structure.

Because the activities produced in the threshold detectors are relatively short-lived, the two structures, 3.3a and 3.3c, that were to be instrumented with these detectors, were equipped with an aluminum tube from which the threshold devices could be withdrawn by means of a cable system within a few minutes after shot time. The structural details of the cable systems are given in Sections 2.3.4 and A.2.1, and illustrated in Figure A.6.

Because none of the other dose detection systems require early recovery, their locations were controlled only by the type of data desired. A film packet, a chemical dosimeter, and in some cases a thermal-neutron detector were installed at each instrument station. Structure 3.3a contained six such stations; 3.3b, three; 3.3c, eight. The location of each instrument station is shown in Figures C.1 and C.2 and is referenced in Tables C.2 and C.3 to a right-handed Cartesian coordinate system with origin at the centroid of the floor of the structure proper. The x direction is taken as positive toward ground zero, y is positive toward the entrance. All dosimeter packets are located 3 feet from the floor except for Stations A and B in 3.3c which are 1 and 4 feet above the floor respectively.

In order to calculate transmission factors it was necessary to obtain free-field readings. Neutron-spectral data was obtained from the line of stations established by Project 2.3 at 100-yard intervals west from ground zero. In addition, chemical dosimeter and film packet free-field stations were located at the same ranges as the structures tested.

C.4 RESULTS AND DISCUSSION

Most of the free-field NBS-ESL film packets, which cannot measure dosages greater than 70,000 r, were overexposed, and the rest were either neutron-activated or lost in processing. Therefore, the free-field film packet data obtained for Project 2.4 were plotted as a function of distance and extrapolated to the ranges of interest (Reference 5). It is recognized that the validity of the linear extrapolation to close ranges is open to question, but no other procedure presented itself. The doses read from this curve are given in Table C.1 along with the other free-field dose measurements. The chemical dosimeter data were obtained from a smoothed curve through the measured values. The threshold-detector dose figures were obtained from Project 2.3 (Reference 8).

Gamma and neutron doses inside the shelters are listed in Tables C.2 and C.3, respectively. Results shown as less than a given figure indicate the lower limit of detector sensitivity in cases where the detector gave no reading. It was evident that these shelters provided adequate protection against initial nuclear radiations under the test conditions, in agreement with predictions made by Project 2.4 (Reference 5). It will be noted that the gamma doses were considerably higher in the entranceways of these structures. Sizeable gamma and neutron doses were received at the bottom of the ventilation shaft of 3.3c; however, the sandbags placed at Position C made it difficult to assess streaming into the structure proper. A comparison of gamma doses received in 3.3b and 3.3c indicates that the positions on the ground-zero side of each structure received smaller doses than those on the other side.

C.5 CONCLUSIONS

The underground shelters constructed by Project 3.3 provided adequate protection against the initial gamma and neutron irradiation from Shot Priscilla at the slant ranges of this test. The radiation protection afforded by these shelters could be improved by better shielding between the entranceway and the shelter. The ventilating system of Structure 3.3c appeared to be adequately designed to minimize streaming of radiation.

TABLE C.1 FREE-FIELD GAMMA AND NEUTRON MEASUREMENTS

Structure	Gamma Dose	Neutron Dose
	Film	Foil Method
	r	rep
3.3a	1.35×10^5	1.24×10^5
3.3b, 3.3c	1.02×10^5	7.65×10^4

TABLE C.2 GAMMA SHIELDING CHARACTERISTICS OF PROJECT 3.3 STRUCTURES, FRENCHMAN FLAT, SHOT PRISCILLA

Earth cover: 5 feet.

Structure	Station	Coordinates		Dose, r		Transmission Factor (D_1/D_0)	
		X	Y	Film Badge	Chemical Dosimeter	Film Badge	Chemical Dosimeter
		R	R				
3.3a	A	+9.5	0	*	<5	—	$<4 \times 10^{-5}$
	B	-9.5	0	*	<5	—	$<4 \times 10^{-5}$
	C	0	+25	*	64	—	4.7×10^{-4}
	D	0	+21	16.2	24	1.0×10^{-4}	1.8×10^{-4}
	E	0	0	*	10	—	7.4×10^{-5}
	F	0	-21	7.4	36	4.6×10^{-5}	2.7×10^{-4}
3.3b	A	+9.5	0	1.2	<5	1.1×10^{-5}	$<5 \times 10^{-5}$
	B	-9.5	0	2.3	<5	2.2×10^{-5}	$<5 \times 10^{-5}$
	C	0	+25	94	94	9.0×10^{-4}	9.2×10^{-4}
3.3c	A	+17.7	+8.2	90	88	8.6×10^{-4}	8.6×10^{-4}
	B	+9.0	+11.0	1.05	<5	1.0×10^{-5}	$<5 \times 10^{-5}$
	C	+2.0	+9.0	5.0	<5	4.8×10^{-5}	$<5 \times 10^{-5}$
	D	0	0	4.5	<5	4.3×10^{-5}	$<5 \times 10^{-5}$
	E	0	-18	4.0	<5	3.8×10^{-5}	$<5 \times 10^{-5}$
	F	-8	+10	3.0	<5	2.9×10^{-5}	$<5 \times 10^{-5}$
	G	+1	+20	15.0	27.7	1.4×10^{-4}	2.7×10^{-4}
	H	0	+25	97	117	9.2×10^{-4}	1.15×10^{-3}

* Lost in processing.

TABLE C.3 NEUTRON SHIELDING CHARACTERISTICS OF PROJECT 3.3 STRUCTURES,
FRENCHMAN FLAT, SHOT PRISCILLA

Earth cover: 5 feet.

Structure	Station	Coordinates		Dose, r		Transmission Factor (D_t/D_0)	
		X	Y	Foil Method	Chemical Dosimeter	Foil Method	Chemical Dosimeter
		R	R				
3.3a	A	+9.0	0	*	<10	*	$<7 \times 10^{-8}$
	B	-9.5	0	*	<10	*	$<7 \times 10^{-8}$
	C	0	+25	*	64	*	4.6×10^{-4}
	D	0	+21	*	14	*	1.0×10^{-4}
	E	0	0	<25	44	$<1.8 \times 10^{-4}$	3.1×10^{-4}
	F	0	-21	*	†	*	†
3.3b	A	+9.5	0	*	<10	*	$<1 \times 10^{-4}$
	B	-9.5	0	*	<10	*	$<1 \times 10^{-4}$
	C	0	+25	*	<10	*	$<1 \times 10^{-4}$
3.3c	A	+17.7	+6.2	*	140	*	1.6×10^{-3}
	B	+9.0	+11.0	*	<10	*	$<1 \times 10^{-4}$
	C	+2.0	+9.0	*	<10	*	$<1 \times 10^{-4}$
	D	0	0	<25	<10	$<2.9 \times 10^{-4}$	$<1 \times 10^{-4}$
	E	0	-16	<25	<10	$<2.9 \times 10^{-4}$	$<1 \times 10^{-4}$
	F	-8.0	+10	*	<10	*	$<1 \times 10^{-4}$
	G	+1.0	+20	*	20	*	2.3×10^{-4}
	H	0	+25	*	<10	*	$<1 \times 10^{-4}$

* Lost in processing.

† Not instrumented.

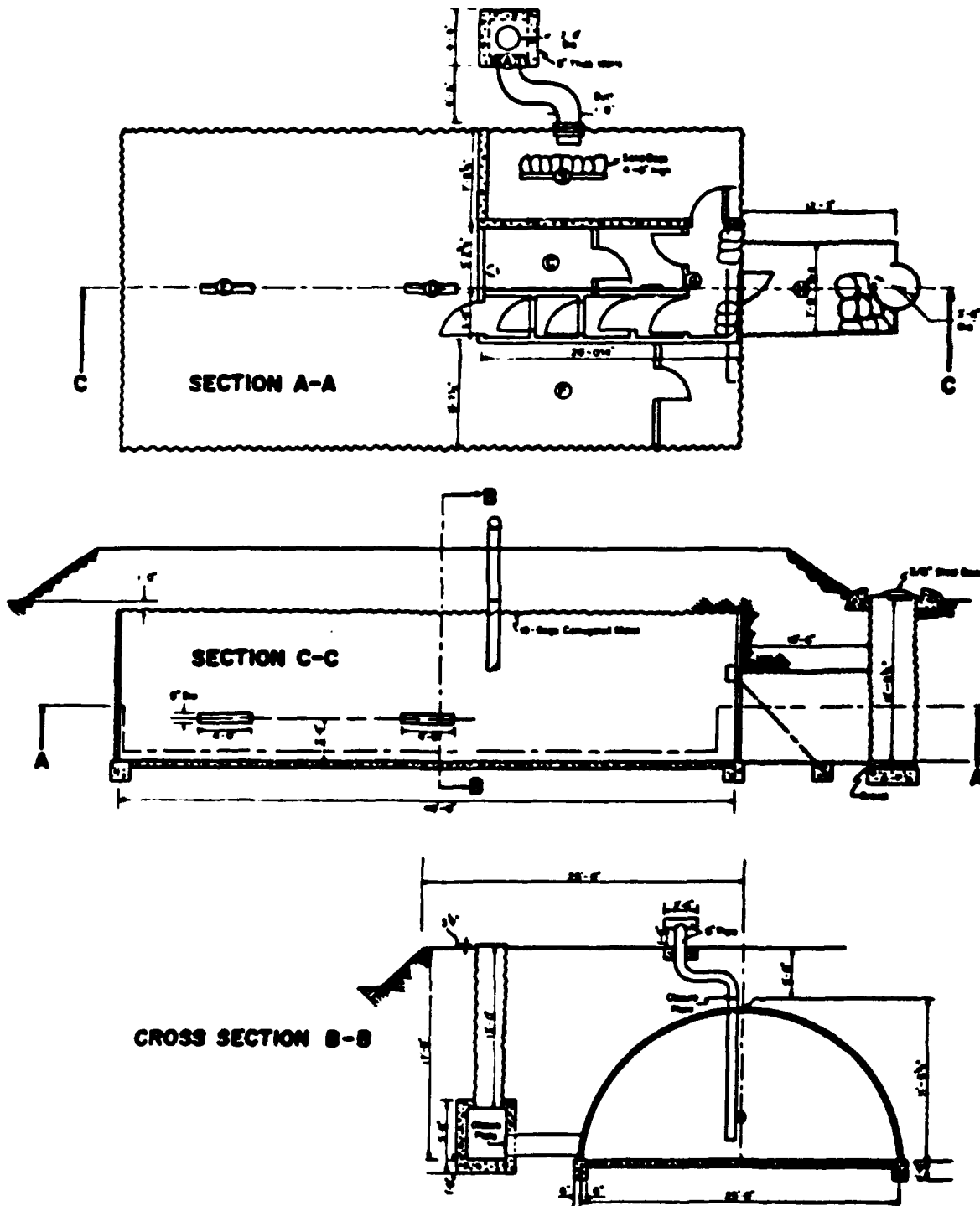

Figure C.1 Location of radiation detectors in Structure 3.3c.

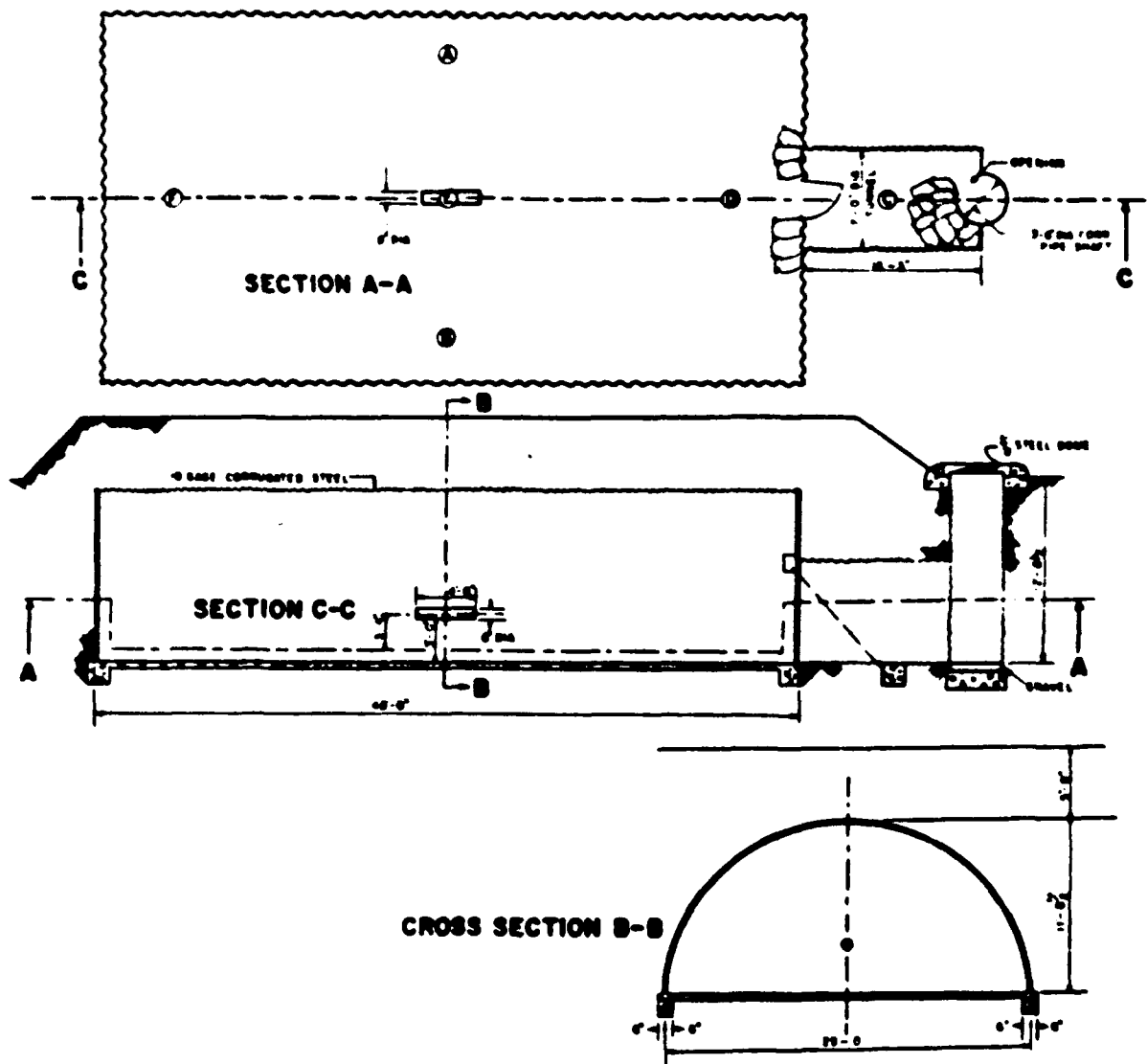

Figure C.2 Location of radiation detectors in Structures 3.3a and 3.3b.

REFERENCES

1. R. B. Valle, Jr. and L. D. Mills; "Evaluation of Earth Cover as Protection to Aboveground Structures"; Project 3.6, Operation Teapot, WT-1128, December 1956; Bureau of Yards and Docks, Department of the Navy, Washington 25, D. C.; Confidential Restricted Data.
2. "Analysis Report for Basic Types of Underground Structures"; For the Waterways Experiment Station, Corps of Engineers, U.S. Army, Vicksburg, Mississippi, performed under Contract No. DA-22-079-ENG-196, October 1956; Holmes and Narver, Inc., Los Angeles, California; Secret Restricted Data.
3. "Handbook of Drainage and Construction Products"; 1955; Armco Drainage and Metal Products, Inc., Middletown, Ohio; Unclassified.
4. C. S. White, M. B. Wetherbe, and V. C. Goldizen; "The Internal Environment of Underground Structures Subjected to Nuclear Blast I. The Occurrence of Dust"; Project 33.5, Operation Plumbbob, ITR-1447, 22 November 1957; Lovelace Foundation for Medical Education and Research, Albuquerque, New Mexico; Unclassified.
5. R. C. Tompkins and others; "Attenuation of Gamma and Neutron Radiation by Armor, Soil, and Structures"; Project 2.4, Operation Plumbbob, ITR-1413, 6 December 1957; U. S. Army Chemical Warfare Laboratories, Army Chemical Center, Maryland; Secret Restricted Data.
6. A. B. Chilton; "Blast Pressure Leakage into Closed Structures Through Small Openings"; NAVDOCKS P-290.1, August 1958, Chapter 31; Unclassified.
7. E. J. Bryant, J. H. Keefer, and J. G. Schmidt; "Basic Air-Blast Phenomena, Part I"; Project 1.1, Operation Plumbbob, ITR-1401, 25 October 1957; Explosion Kinetics Branch, Terminal Ballistic Laboratory, Ballistic Research Laboratories, Aberdeen Proving Ground, Maryland; Confidential Formerly Restricted Data.
8. D. L. Rigotti and others; "Neutron Flux from Selected Nuclear Devices"; Project 2.3, Operation Plumbbob, WT-1412, 28 April 1960; U. S. Army Chemical Warfare Laboratories, Army Chemical Center, Maryland; Secret Restricted Data.
9. L. M. Swift, D. C. Sachs, and F. M. Sauer; "Ground Acceleration, Stress, and Strain at High Incident Overpressures"; Project 1.4, Operation Plumbbob, WT-1404, 10 May 1960; Stanford Research Institute, Menlo Park, California; Secret Formerly Restricted Data.
10. L. M. Swift and D. C. Sachs; "Ground Motion Produced by Nuclear Detonations"; Project 1.8, Operation Hardtack, ITR-1613, 14 August 1958; Stanford Research Institute, Menlo Park, California; Secret Formerly Restricted Data.
11. W. R. Perret; "Ground Motion Studies at High Incident Overpressure"; Project 1.5, Operation Plumbbob, WT-1405, 20 June 1960; Sandia Corporation, Albuquerque, New Mexico; Unclassified.
12. W. R. Perret and V. L. Gentry; "Free-Field Measurements of Earth Stress, Strain, and Ground Motion"; Project 1.4, Operation Upshot-Knothole, WT-716, February 1955; Sandia Corporation, Albuquerque, New Mexico; Secret Formerly Restricted Data.
13. R. E. Woodring, G. E. Sinsamoc, and N. M. Newmark; "Air Blast Effects on Underground Structures"; Project 3.4, Operation Teapot, WT-1127, 20 August 1957; University of Illinois, Urbana, Illinois and Office Chief of Engineers, U. S. Army, Washington, D. C.; Confidential Formerly Restricted Data.

14. E. H. Bultmann, Jr., E. Sevin, and T. H. Schiffman; "Blast Effects on Existing Upshot-Knothole and Teapot Structures"; Project 3.4, Operation Plumbbob, WT-1423, 6 May 1960; Armour Research Foundation, Chicago 16, Illinois and Structures Division, Research Directorate, Air Force Special Weapons Center, Kirtland Air Force Base, New Mexico; Confidential.
15. E. H. Bultmann, Jr., G. F. McDonough, and G. K. Sinnamon; "Loading on Simulated Buried Structures at High Incident Overpressures"; Project 1.7, Operation Plumbbob, WT-1406, 18 April 1960; University of Illinois, Urbana, Illinois and Research Directorate, Air Force Special Weapons Center, Air Research and Development Command, Kirtland Air Force Base, New Mexico; Confidential Formerly Restricted Data.
16. E. H. Bultmann, Jr., G. F. McDonough, and G. K. Sinnamon; "Loading on Buried Simulated Structures in High-Overpressure Regions"; Project 1.9, Operation Hardtack, ITR-1614-1, 25 July 1958, Secret Formerly Restricted Data, and ITR-1614-2, 28 November 1958, Confidential Formerly Restricted Data; University of Illinois, Urbana, Illinois and Research Directorate, Air Force Special Weapons Center, Air Research and Development Command, Kirtland Air Force Base, New Mexico.
17. J. C. LeDoux and P. J. Rush; "Response of Earth-Confined Flexible-Arch-Shell Structures in High-Overpressure Region"; Project 3.2 Supplement, Operation Hardtack, ITR-1626-2, 10 April 1959; U. S. Naval Civil Engineering Laboratory, Port Hueneme, California; Secret Formerly Restricted Data.
18. S. Ruff; "Brief Acceleration-Chapter VI-C in German Aviation Medicine, World War II"; U. S. Government Printing Office; Pages 584-597, 1950; Unclassified.
19. S. Glasstone; "The Effects of Nuclear Weapons"; 1957; U. S. Government Printing Office, Washington 25, D. C.; Unclassified.
20. "Radiological Recovery of Fixed Military Installations"; Department of Army Technical Manual TM 3-225 and Department of the Navy NAVDOCKS TP-PL-13, 1958; Unclassified.
21. F. G. Ort and M. D. Mears; "Development of the Closure, Protective Shelter, Anti-Blast, 600 CFM, E19R1-Part II"; U. S. Army Chemical Warfare Laboratories Technical Report CWLR 2275, March 1959; Army Chemical Center, Maryland; Confidential.
22. T. B. Goode and others; "Soil Survey and Backfill Control in Frenchman Flat"; Project 3.8, Operation Plumbbob, WT-1427, 23 October 1959; U. S. Army Engineer Waterways Experiment Station, Corps of Engineers, Vicksburg, Mississippi; Unclassified.
23. A. P. Flynn; "FCDA Family Shelter Evaluation"; Project 9.1a, Operation Buster, WT-359, March 1952; Federal Civil Defense Administration, Washington 25, D. C.; Confidential Formerly Restricted Data.
24. J. R. Hendrickson and others; "Shielding Studies"; Project 2.7, Operation Teapot, WT-1121, 1 April 1957; Chemical Warfare Laboratories, Army Chemical Center, Maryland; Secret Restricted Data.
25. T. Rockwell III; "Reactor Shielding Design Manual"; AEC-TID 7004, Page 261 ff, March 1956; U. S. Atomic Energy Commission, Washington, D. C.; Unclassified.
26. J. B. Graham and others; "Gamma Exposure versus Distance"; Project 2.1, Operation Teapot, WT-1115, 23 October 1959; U. S. Army Signal Research and Development Laboratory, Fort Monmouth, New Jersey; Secret Restricted Data.
27. M. Ehrlich; "Photographic Dosimetry of X- and Gamma Rays"; Handbook 57, Page 10, August 1954; U. S. Department of Commerce, National Bureau of Standards, Washington, D. C.; Unclassified.
28. M. Ehrlich and S. H. Fitch; "Photographic X- and Gamma Ray Dosimetry"; Nucleonics, September 1951, Vol. 9, No. 3, Pages 5-17, McGraw-Hill Publishing Company, Inc.; Unclassified.

29. S. C. Sigoloff, J. A. Borella, and J. A. Auxier; "Dosimetry Report, Biological Effects from Massive Doses of Neutron Gamma Radiation"; USAF Report No. 55-108; School of Aviation Medicine, USAF, Randolph Air Force Base, Texas; Unclassified.

30. S. C. Sigoloff; "Fast Neutron Insensitive Gamma Ray Dosimeters—The AC and ACTE Systems"; School of Aviation Medicine, USAF, Randolph Air Force Base, Texas; Unclassified.

31. G. V. Taplin and others; "Comparison and Evaluation of Dosimetry Methods Applicable to Gamma Radiation"; Project 28.1, Operation Upshot-Knothole, WT-802, September 1953; School of Medicine, Atomic Energy Project, University of California at Los Angeles, California; Confidential Restricted Data.

32. G. V. Taplin and others; "Measurement of Initial and Residual Radiation by Chemical Methods"; Project 39.6, Operation Teapot, ITR-1171, May 1955; Atomic Energy Project, School of Medicine, University of California at Los Angeles, California; Secret Restricted Data.

33. P. S. Harris and others; "Physical Measurement of Neutron and Gamma Radiation Dose from High Neutron Yield Weapons and Correlation of Dose with Biological Effect"; Project 39.7, Operation Teapot, ITR-1167, April 1955; Los Alamos Scientific Laboratory, Los Alamos, New Mexico and others; Secret Restricted Data.

34. E. V. Brouillete; "Corrosion Studies Associated with an Air Blast Closure Unit"; Technical Note N-360 of 30 July 1959; U. S. Naval Civil Engineering Laboratory, Port Hueneme, California; Unclassified.

SUPPLEMENTARY

INFORMATION



SSTL

Defense Nuclear Agency
6801 Telegraph Road
Alexandria, Virginia 22310-3398

ERRATA

14 September 1995

AD-615 737

MEMORANDUM TO DEFENSE TECHNICAL INFORMATION CENTER
ATTN: OCD/Mr Bill Bush

SUBJECT: Change of Distribution Statement

The following documents have been downgraded to Unclassified and the distribution statement changed to Statement A:

- | | |
|---------------------|--------------------|
| WT-1307, AD-311926 | WT-1305, AD-361774 |
| POR-2011, AD-352684 | WT-1303, AD-339277 |
| WT-1405, AD-611229 | WT-1408, AD-344937 |
| WT-1420, AD-B001855 | WT-1417, AD-360872 |
| WT-1423, AD-460283 | WT-1348, AD-362108 |
| WT-1422, AD-615737 | WT-1349, AD-361977 |
| WT-1225, AD-460282 | WT-1340, AD-357964 |
| WT-1437, AD-311158 | |
| WT-1404, AD-491310 | |
| WT-1421, AD-691406 | |
| WT-1304, AD-357971 | |

15126/8

If you have any questions, please call MS Ardith Jarrett, at 325-1034.

FOR THE DIRECTOR:

Ardith Jarrett
for JOSEPHINE WOOD
Chief
Technical Support

ERRATA

SUPPLEMENTARY

INFORMATION



SSTL

Defense Nuclear Agency
6801 Telegraph Road
Alexandria, Virginia 22310-3398

ERRATA

14 September 1995

AD-615737

MEMORANDUM TO DEFENSE TECHNICAL INFORMATION CENTER
ATTN: OCD/Mr Bill Bush

SUBJECT: Change of Distribution Statement

The following documents have been downgraded to Unclassified and the distribution statement changed to Statement A:

- | | |
|---------------------|--------------------|
| WT-1307, AD-311926 | WT-1305, AD-361774 |
| POR-2011, AD-352684 | WT-1303, AD-339277 |
| WT-1405, AD-611229 | WT-1408, AD-344937 |
| WT-1420, AD-B001855 | WT-1417, AD-360872 |
| WT-1423, AD-460283 | WT-1348, AD-362108 |
| WT-1422, AD-615737 | WT-1349, AD-361977 |
| WT-1225, AD-460282 | WT-1340, AD-357964 |
| WT-1437, AD-311158 | |
| WT-1404, AD-491310 | |
| WT-1421, AD-691406 | |
| WT-1304, AD-357971 | |

If you have any questions, please call MS Ardith Jarrett, at 325-1034.

FOR THE DIRECTOR:

for *Ardith Jarrett*
JOSEPHINE WOOD
Chief
Technical Support

ERRATA

151.20/8