

ESD TDR 65-225

ESTI FILE COPY

ESD-TDR-65-225

ESD RECORD COPY

RETURN TO
SCIENTIFIC & TECHNICAL INFORMATION DIVISION
(ESTI), BUILDING 1211

ESTI PROCESSED

DDC TAB PROJ OFFICER

ACCESSION MASTER FILE

DATE _____

ESTI CONTROL NR. AL 46606

CY NR. / OF / CYB

Technical Note

1965-19

Commutating Feed for Circular Array Antenna and its Application to the LES

J. B. Rankin

24 May 1965

ESRL

Prepared under Electronic Systems Division Contract AF 19(628)-500 by

Lincoln Laboratory

MASSACHUSETTS INSTITUTE OF TECHNOLOGY

Lexington, Massachusetts



ADD 616986

MASSACHUSETTS INSTITUTE OF TECHNOLOGY
LINCOLN LABORATORY

COMMUTATING FEED FOR CIRCULAR ARRAY ANTENNA
AND ITS APPLICATION TO THE LES

J. B. RANKIN

Group 61

TECHNICAL NOTE 1965-19

24 MAY 1965

LEXINGTON

MASSACHUSETTS

ABSTRACT

A commutator for a circular antenna array is described using multi-throw switches fed in parallel through a power divider. The excitation phases of the elements can be controlled by phasing elements located between the power divider and the switches. In applications requiring excitation of only a few radiators at a time, each phasing element might simply be a diode together with tuning reactances. Application of the commutator and phasing scheme to a step-scanned antenna for LES-5 or 6 is described. The commutator arrangement was proposed by W. E. Morrow, Jr.

Accepted for the Air Force
Stanley J. Wisniewski
Lt Colonel, USAF
Chief, Lincoln Laboratory Office

COMMUTATING FEED FOR CIRCULAR ARRAY
ANTENNA AND ITS APPLICATION TO THE LES

I. COMMUTATOR USING SINGLE-THROW SWITCHES

In a memorandum to L. J. Ricardi, dated 10 December 1964, W. E. Morrow, Jr. proposed a novel commutator arrangement for step scanning the antenna beam of a circular array of radiators. His commutator consists of a number of parallel-fed single-pole 4-throw (SP4T) switches such as developed by Dr. R. N. Assaly. Each radiator might be a slotted waveguide antenna such that the circular array forms a cylinder. Figure 1 shows a cylindrical array of 24 slotted waveguides. The purpose of this note is to discuss the idea and some possible variations. I feel that one or more variations represent a reasonable approach to an electronically step-scanned beam with more gain than LES-4. No changes are suggested, however, for LES-4 itself.

Let M = the number of switches.

A = the number of arms or throws for each switch.

$N = A \times M$ = the number of radiators in the circle.

One arrangement would be 32 radiators fed from eight SP4T switches, which W. E. Morrow, Jr. used to illustrate the idea. Number the radiators consecutively around the circle from 1 to 32. The arms of the first switch are connected to elements 1, 9, 17, and 25; those of the second switch to 2, 10, 18, and 26, etc. The switches are fed in parallel through an 8-way power divider and one arm from each is turned on. When the first arm of each is

turned on, radiators 1 through 8 are illuminated. The beam is step scanned $360^\circ/N$, $11-1/4^\circ$ here, by turning radiator 1 off and radiator 9 on; that is, switch #1 switches from its first to second arm. Then the second switch operates, and so on. Mechanically the switches may be stacked one above the other and each turned $11-1/4^\circ$ with respect to the one above (and below) it, as may be inferred from Fig. 1. Two principal features of the commutator and circular array idea are:

- (1) The signal goes through only one stage of switching.
- (2) There is an economy of hardware in that of the 32 radiators giving 32 beam positions, 8 are used at a time. All switches are used all the time.

The commutator arrangement described here would excite the M simultaneously-fed radiators in phase, provided the line length from the power divider input to all radiators was the same. Furthermore, as will be shown later, the phase (and amplitude) excitation for one adjacent set of radiators holds for any adjacent set.

II. PHASE AND AMPLITUDE CONTROL

For many applications, probably including a spin-stabilized satellite, in-phase excitation is not the best choice. A phase and amplitude control scheme will be described which is especially suited to a small number of radiators illuminated at a time. It is similar to one proposed by Dr. A. Grayzel for VHF in a memorandum dated 9 March 1965. Consider 24 radiators fed four at a time as pictured in Figs. 1 and 2. Four 6-throw switches

(labeled A, B, C, and D), a four-way power divider, and four phasing elements (labeled a, b, c, and d) are used. Switches with more than four throws will be discussed in the next section.

Figure 2a shows the ring of 24 consecutively labeled radiators. Radiators 4, 8, 12, 16, 20, and 24 are connected to switch D, which is shown. Radiators 1, 5, ----- are connected to switch A; 2, 6, ----- to B; and 3, 7, ----- to C. Switches A, B, and C are not shown. When radiators 1, 2, 3, and 4 (one for each switch) are turned on, the antenna beam will point in the direction indicated. Radiators 1 and 4 are the edge radiators of the illuminated arc, and 2 and 3 are the center radiators.

The four switches are connected together in a four-way power divider shown in Fig. 2b. Let l_a = electrical line length from switch A to each of its radiators.

Similarly l_b , l_c , and l_d .

l'_a = electrical line length from power divider to switch A.

Similarly l'_b , l'_c and l'_d .

Because of the stacked configuration of the switches, l_a , l_b , l_c , and l_d are different electrical lengths. But for impedance purposes, they should differ by multiples of a half wavelength. Likewise l'_a , l'_b , l'_c , and l'_d should differ by multiples of a half wavelength (unless they are equal). Furthermore, $l_a + l'_a$, $l_b + l'_b$, $l_c + l'_c$, and $l_d + l'_d$ must be equal or differ by multiples of one wavelength. Thus the impedances seen by the four arms of the power

divider are equal, except for the effects of mutual impedance.

Now for the beam pointing in the direction shown, the excitation phase of edge radiators 1 and 4 should lead that of center radiators 2 and 3 by

$$360^\circ \frac{R}{\lambda} \left(\cos \frac{180^\circ}{N} - \cos \frac{3 \times 180^\circ}{N} \right) = 77-1/2^\circ \text{ in this example, where } R \text{ is the}$$

radius and λ is the wavelength, if zero excitation phase error is desired.

The differential phase delay can be introduced by elements a, b, c, and d in the lines going from the power divider to the four switches. It should be possible to adjust the transfer impedances Z_a , Z_b , Z_c , and Z_d of elements a, b, c, and d to take care of amplitude taper and the effects of mutual impedance among the radiators. Now from symmetry about the beam direction, Z_a and Z_d should be alike; these are marked by a Δ to indicate the required phase lead of radiators 1 and 4. Similarly Z_b and Z_c should be alike; these are marked 0 to indicate that radiators 2 and 3 have the reference phase. Hence two adjacent elements (a and d) are in state Δ , and the other two are in state 0.

When a switch A turns radiator 1 off and 5 on, the signal from A still goes to an edge radiator; hence element "a" should remain in state Δ . The signal from C still goes to a center radiator (3); hence element c should remain in state 0. Since radiator 2 changes from a center to an edge radiator and 4 from an edge to a center radiator, element b should change from state 0 to state Δ and d should change from Δ to 0.

A similar procedure occurs when switch B turns radiator 2 off and 6 on. Thus, while the individual states of a, b, c, and d must change back and forth between 0 and Δ , at any instant two adjacent elements must be 0 and the other two Δ . The input impedance to the power divider remains constant, except during switching. Furthermore, the beam shape and gain are independent of beam direction. Now if more than four radiators are excited at one time so that more than two excitation phases are required, the phasing system gets more complicated. But it could be shown that the input impedance and the effects of mutual impedance on phasing element requirements remain independent of beam direction. The scheme drawn in Fig. 2 for four switches and six throws per switch could be described in more general terms. This will not be done here.

III. MULTI-THROW SWITCH

Dr. Assaly's original multi-throw switch had four throws. He is currently building an 8-throw unit by stacking two SP4T units (with dimensional modifications). Only one arm of the eight is turned "on" at a time. Similarly, it should be possible to stack two 3-throw units to make a SP6T switch, or perhaps this can be built with one layer of arms.

IV. SUMMARY OF CHARACTERISTICS OF COMMUTATOR AND PHASING SYSTEM

Some numerical properties, including antenna dimensions, of the commutator and phasing scheme are tabulated in Table 1 for different numbers of

switches and throws per switch. Dimensions are based on an element spacing of approximately $3\lambda/4$. Since $\pi/2$ " is close to a wavelength at 8000 MHz, spacing used is $3\pi/8$ ". Dimensions in the table do not include circularly polarizing hardware around the circular array. Nor does the table include circumferential pattern shaping by radial extension of the hardware. The row marked "Incremental Scan Angle + 20°" is included because this gives the required circumferential (relative to the circular array) coverage for each antenna beam from a synchronous altitude satellite with its spin axis perpendicular to the orbital plane.

The X-band transmitting antenna being built for LES-4 fits into the table as Case #1. Each element is a four-slot waveguide antenna with a circular polarizer and flared horn extending outward from the slotted face. The example W. E. Morrow used to describe the idea was Case #8. Case #10 gives numbers corresponding to the scheme proposed by Dr. A. Grayzel for a VHF-UHF open-circular array. Except he chose to connect his switches so as to excite alternate instead of consecutive elements at any instant.

V. APPLICATION TO LES-5 or 6 SATELLITE

Now let us see what the hardware designed for near maximum gain might look like when applied to a LES-5 or 6 satellite spin stabilized with its axis perpendicular to the plane of the orbit. Also, what improvement in antenna gain over LES-4 might be obtained. It was already decided that the only hardware which could be delivered in time for LES-4 was a simple 8-position

switched beam system using one aperture at a time. The LES-4 antenna has a required azimuth coverage of $20^\circ + 360^\circ/8 = 65^\circ$, which is obtained from a flared horn 1-3/4 inch wide. The 20° is 16° for the diameter of the earth plus 4° for switching error. The gain at the edge of the beam is about 5 db down from the peak gain of 14-1/2 db for a single antenna. Twenty-four beam positions would reduce the required coverage to $20^\circ + 360^\circ/24 = 35^\circ$. Now if the 5 db width of 65° in one plane is compressed to 35° (or about half), then the power gain should double. This 3 db increase applies to the peak of the beam, the edges, and in between. Doubling the power gain by compressing the beam to half size implies that the power within the 5 db contour of the wider beam be confined within the 5 db contour of the sharper beam. The aperture width of 4-1/2 inches for case #6 is more than enough to give a beam 35° wide. In fact either amplitude taper must be used in the azimuth direction or a non-uniform phase over the aperture, or both.

Each of the 24 elements might be a waveguide standing on end with four or five offset axial slots in its outward facing broad wall, the 24 guides arranged in a cylinder 9 inches in diameter. The use of five slots per guide would permit some pattern shaping in elevation. Adjacent guides would touch; and perhaps all guides would be trapezoidal in cross section so as to have common narrow walls. The 120 slots would be in five layers. Polarization coming out of the slots would be horizontal. The circular polarizing scheme would be something like that used on LES-4. Six horizontal circular plates would

extend outward from the cylindrical array spaced $\lambda g/2$ apart as shown in Fig. 3. About 1-1/2 inches in front of the slots and held between all the parallel plates would be a grid of vanes inclined 45° . Radiation emerging through the vanes would be 45° linear, which can be resolved into axial and circumferential components. A radial extension of the plates would complete the circular polarizer. If vertical plates were used for the polarizer rather than horizontal, as proposed here, one of two problems would have to be solved. Radial vertical plates would not be parallel and design of the polarizer would be appreciably more difficult. Parallel vertical plates would leave gaps at the aperture which might cause high side lobes. Horizontal plates offer a bonus: they permit amplitude taper in the vertical direction and therefore some elevation pattern shaping.

The phase elements - a, b, c, and d - might simply be diodes placed across the arms of the power divider along with appropriate series reactances and shunt susceptances. Two adjacent diodes would be forward biased and the other two reverse biased. The forward and reverse biased transfer admittances would be designed to give the desired amplitude and phase relations between the two states.

The system described here should have an increase in gain of about 2 db over LES-4. This is broken down as follows: The expected improvement in pattern directivity is about 3 db. Since there is one stage of switching both here and in LES-4, the attenuation due to switching should be the same. The

The diodes for phase correcting plus the additional length of waveguide in this scheme should add no more than one db of attenuation, leaving a net improvement of 2 db. This system should give some continuity of signal during switching because at least three (out of four) elements are always on, and of these three, the phases of two remains constant at switch-over. Whether a 2 db improvement in LES antenna gain is worth the added weight and complexity depends on whether the 2 db are needed and whether they can be more readily obtained through improved transmitter efficiency or more power from solar cells.

VI. CIRCULAR ARRAY OF 40 RADIATORS

A larger version of the switching and phase correcting scheme not intended for LES-5 or 6 is Case #11 in Table 1, 40 elements fed five at a time requiring five 8-throw switches. On account of the larger radius for 40 elements, the center three elements could be fed in phase with only a $23\text{-}1/2^\circ$ aperture phase error in the direction of the beam. Two excitation phases would then be required, one for the center three elements, and the other for the outer two. The half-power beamwidth is 15° and the incremental scan angle is 9° .

VII. PRINCIPAL AREAS OF WORK

One principal problem area in the commutating feed is the scheme for controlling phases and amplitudes of the radiators excited, indicated in Fig. 2b. If there is application for a step-scanned antenna of a beamwidth appropriate to four or five radiators on an arc ($15^\circ \leq \text{HPBW} \leq 35^\circ$) then development of a

two-state diode waveguide element of the type shown in Fig. 2b should be worthwhile. The difficulty of the task ought to be comparable to that of making a good SPST switch, which has already been developed. As for the switching portion of the commutator, good SP4T switches have been built; SP8T switches are being built. A SP6T switch should be feasible.

The other problem area is obtaining circular polarization. I have proposed using 45° vanes to give 45° linear polarization (Fig. 3) and then horizontal plates to act as a quarter-wave plate circular polarizer. Two apparent problems in this approach are fabrication of the structure, especially the 45° vanes, and electrical reflection from the vanes and its effect on the azimuth pattern. Of particular concern is mutual impedance between the illuminated and adjacent non-illuminated portions of the cylinder in the presence of the vanes. Additional polarizing schemes should be considered.

VII. CONCLUSION

The switching and phasing scheme offers a novel commutator using multi-throw switches of a type already developed in which the signal has to pass only one stage of switching and in which the input impedance and consequences of mutual impedance are independent of beam direction.

SLOTS ARE DRAWN ON ONLY 3 WAVEGUIDES

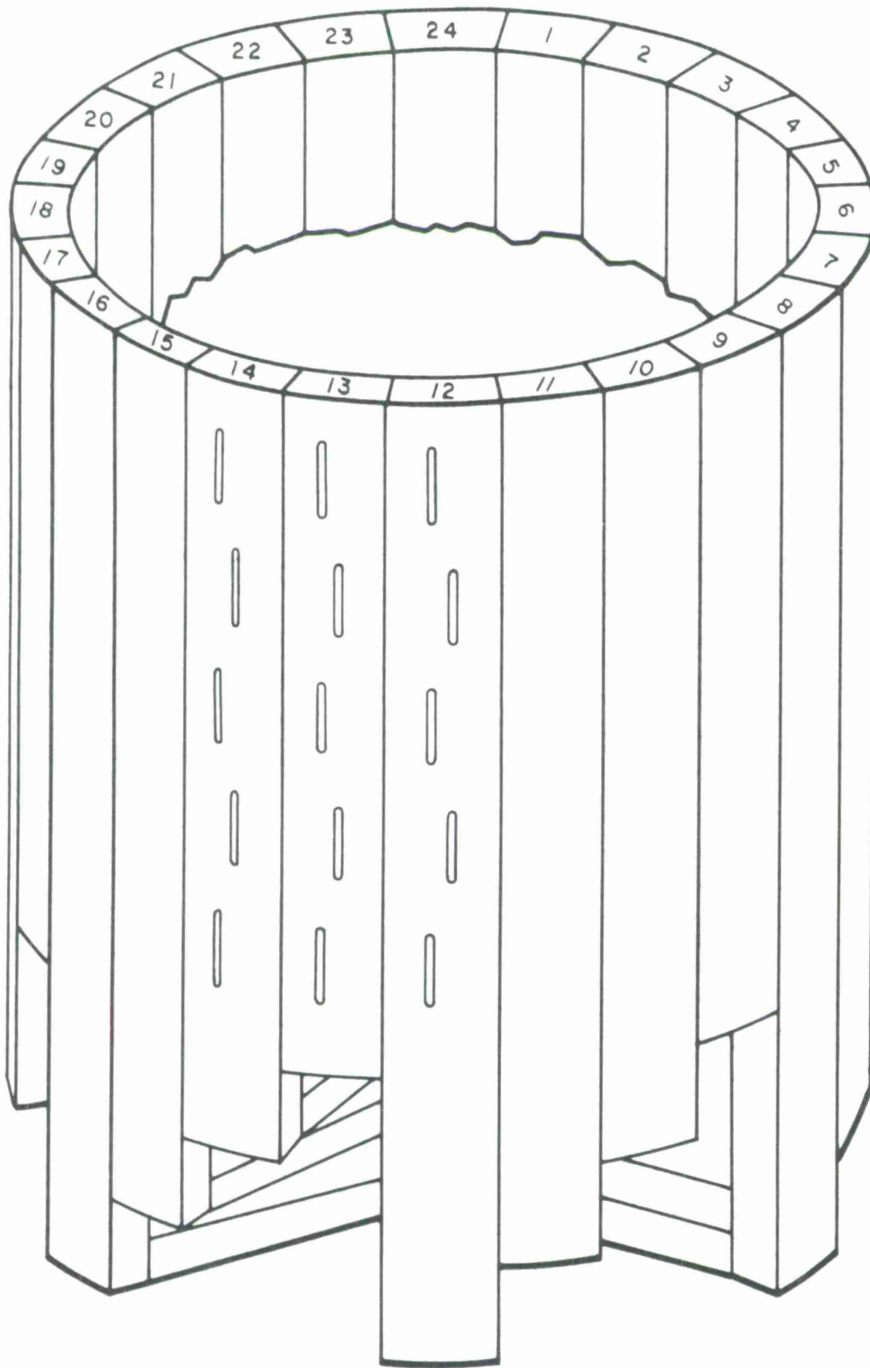

Fig. 1. Cylindrical array of 24 slotted waveguides.

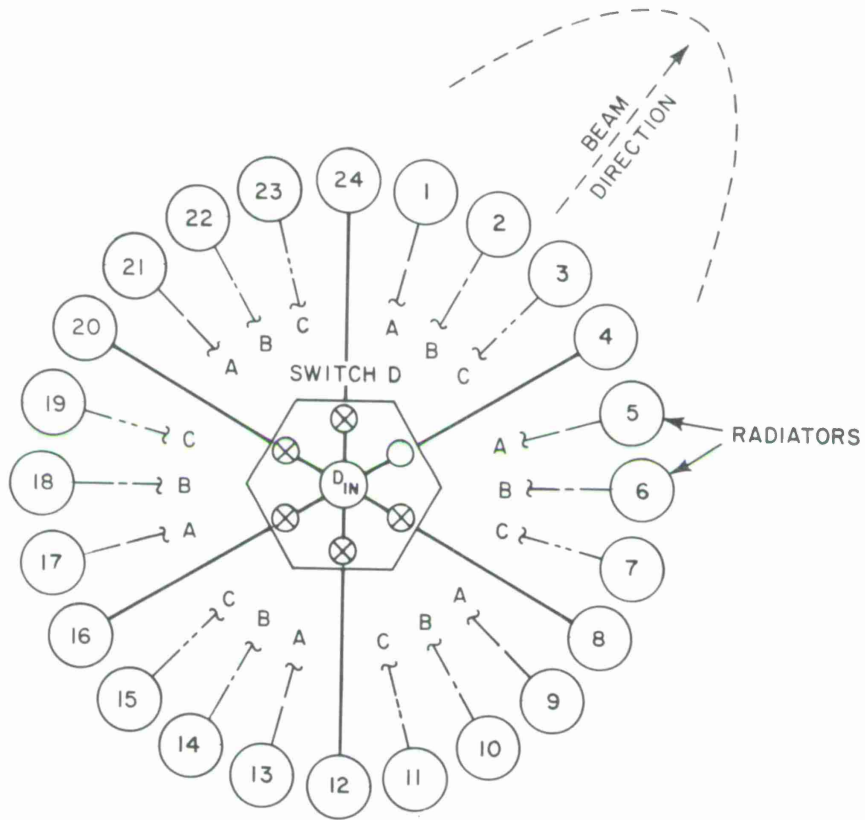

Fig. 2a. Circular array and switching network.

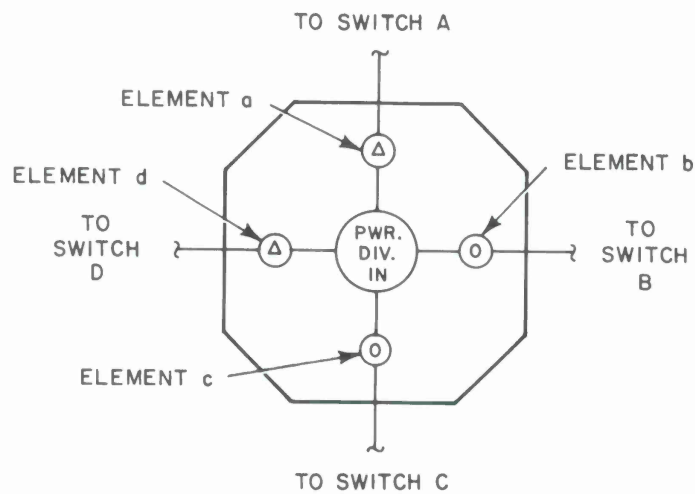

Fig. 2b. Power divider and phasing network.

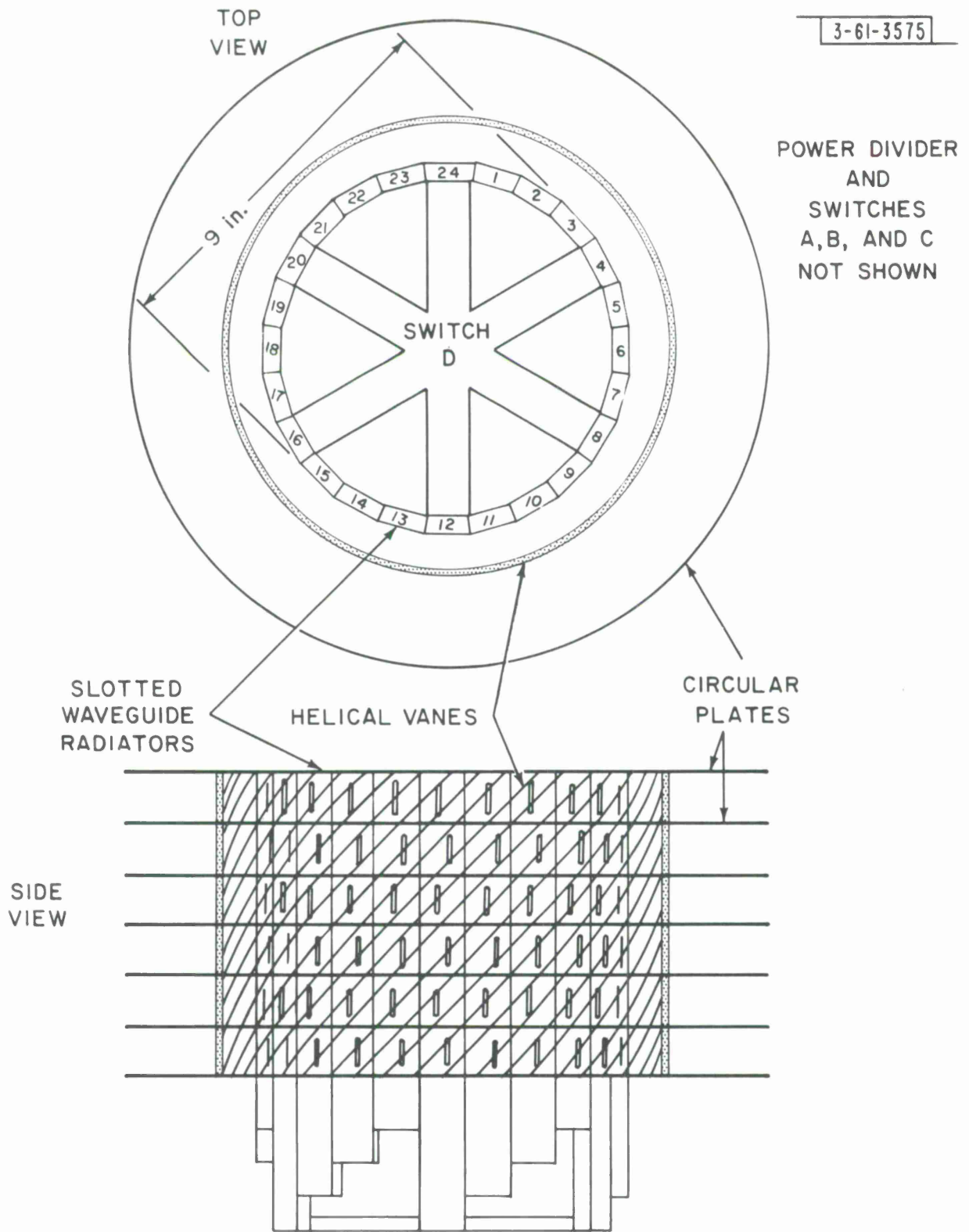

Fig. 3. Circular polarizer for cylindrical array antenna.

Symbol	Item	Cases										
		1	2	3	4	5	6	7	8	9	10	11
N	Number of radiators =	8	8	16	16	24	24	32	32	36	8	40
	Number of beam directions											
	Incremental scan angle	45°	45°	22-1/2°	22-1/2°	15°	15°	11-1/4°	11-1/4°	10°	45°	9°
	Incremental scan angle + 20°	65°	65°	42-1/2°	42-1/2°	35°	35°	31-1/4°	31-1/4°	30°	65°	29°
M	Number of switches =	1	2	2	4	3	4	4	8	6	4	5
	Number of radiators per beam											
A	Number of throws or arms per switch	8	4	8	4	8	6	8	4	6	2	8
	Fraction of circumference per beam	1/8	1/4	1/8	1/4	1/8	1/6	1/8	1/4	1/6	-	1/8
	Number of excitation phases per beam	1	1	1	2	2	2	2	4	3	2	2*
S	Element spacing along the arc	-	-	-	$\frac{3\pi''}{8}$	in numerical examples			-	-	-	-
D	Diameter	3"	3"	6"	6"	9"	9"	12"	12"	13-1/2"	-	15"
W	Width of aperture	2"***	2.1"	2.3"	4-1/4"	3.4"	4.5"	4.6"	8.5"	6-3/4"	-	5-3/4"
HPBW	Half-power beamwidth, degrees	-	40-1/2°	37°	20°	25°	19°	18-1/2°	10°	12-1/2°	-	14-3/4°
	Aperture phase error, degrees (not useful for M = 1, 2)	-	-	-	214°	84°	147°	111°	429°	221°	-	139°

* Center three radiators fed in phase
23-1/2° phase error

** With horn added

TABLE Ia
 NUMERICAL PROPERTIES OF COMMUTATOR AND
 PHASING SCHEME FOR CIRCULAR ANTENNA ARRAY

<u>Symbol</u>	<u>Item</u>	<u>Formula</u>
N	} Number of radiators = } Number of beam directions	MA
		Incremental scan angle
	Incremental scan angle + 20°	$(360^\circ/N) + 20^\circ$
	M	} Number of switches = } Number of radiators per beam
A	Number of throws or arms per switch	
	Fraction of circumference per beam	$1/A$
	Number of excitation phases per beam	M/2 for M even (M + 1)/2 for M odd
S	Element spacing along the arc	$\frac{3}{4} \times \frac{\pi}{2 \times 1.4754} \times \lambda \times 8000$
D	Diameter	$\frac{NS}{\pi} = \frac{3}{8} N''$
W	Width of aperture	$\frac{NS}{\pi} \sin \frac{180^\circ}{A}$
HPBW	Half-power beamwidth, degrees	$\frac{62\lambda}{W}$
	Aperture phase error, degrees (not useful for M = 1, 2)	$\frac{360^\circ NS}{2\pi\lambda} (1 - \cos \frac{180^\circ}{A})$

TABLE Ib

NUMERICAL PROPERTIES OF COMMUTATOR AND PHASING SCHEME FOR CIRCULAR ANTENNA ARRAY

DISTRIBUTION

Division 6

Dinneen, G. P.
Morrow, W. E. (2)

Group 65

Wood, R. V.
Enticknap, R. G.

Group 61

Ricardi, L. J. (10)
Assaly, R. N.
Burrows, M. L.
Crane, R. K.
Devane, M. E.
LaPage, B. F.
Lindberg, C. A.
Niro, L.
Peck, R. J.
Rankin, J. B.
Rosenthal, M. L.
Sotiropoulos, A.

Group 66

Reiffen, B.

Division 4

Weiss, H. G.

Group 44

Allen, J. L.

Group 46

Jones, C. W.
Keeping, K. J.
Sheftman, F. I.

Group 62

Rosen, P. (4)

Group 63

Sherman, H.
Lerner, R. M.
MacLellan, D. C.
Waldron, P.
Berg, R. S.
Grayzel, A. I.
Sarles, F. W.

Group 64

Green, P.

