

AD

AD 624213

USAAVLABS TECHNICAL REPORT 64-686

HEAVY-LIFT TIP TURBOJET ROTOR SYSTEM

VOLUME VII

WEIGHT AND BALANCE STUDIES

CLEARINGHOUSE FOR FEDERAL SCIENTIFIC AND TECHNICAL INFORMATION			
Hardcopy	Microfiche		
\$2.00	\$0.50	30	BAI
ARCHIVE COPY			

October 1965

code 1

U. S. ARMY AVIATION MATERIEL LABORATORIES
FORT EUSTIS, VIRGINIA

CONTRACT DA 44-177-AMC-25(T)
HILLER AIRCRAFT COMPANY, INC.



DDC Availability Notices

Qualified requesters may obtain copies of this report from DDC.

This report has been furnished to the Department of Commerce for sale to the public.

Disclaimers

The findings in this report are not to be construed as an official Department of the Army position, unless so designated by other authorized documents.

When Government drawings, specifications, or other data are used for any purpose other than in connection with a definitely related Government procurement operation, the United States Government thereby incurs no responsibility nor any obligation whatsoever; and the fact that the Government may have formulated, furnished, or in any way supplied the said drawings, specifications, or other data is not to be regarded by implication or otherwise as in any manner licensing the holder or any other person or corporation, or conveying any rights or permission, to manufacture, use, or sell any patented invention that may in any way be related thereto.

Disposition Instructions

Destroy this report when it is no longer needed. Do not return it to the originator.

Task 1M12140D14412
Contract DA 44-177-AMC-25(T)
USAAVLABS Technical Report 64-68G
October 1965

HEAVY-LIFT TIP TURBOJET ROTOR SYSTEM

VOLUME VII

WEIGHT AND BALANCE STUDIES

Hiller Engineering Report No. 64-47

Prepared by

**Hiller Aircraft Company, Inc.
Subsidiary of Fairchild Hiller Corporation
Palo Alto, California**

For

**U. S. ARMY AVIATION MATERIEL LABORATORIES
FORT EUSTIS, VIRGINIA**

(U. S. Army Transportation Research Command when report prepared)

CONTENTS

	<u>Page</u>
SYMBOLS	iv
1.0 SUMMARY	1
1.1 Weight Studies	1
1.2 Balance Studies	4
1.2.1 Rotor Balance Considerations	4
1.2.2 Aircraft Balance	6
2.0 CONCLUSIONS	7
3.0 WEIGHT STUDIES	8
3.1 Rotor Group	8
3.2 Pylon Group	9
3.3 Tail Group	9
3.4 Body Group	10
3.5 Landing Gear Group	10
3.6 Flight Controls Group	10
3.7 Engine Section Group	10
3.8 Propulsion Group	10
3.9 Instrument Group	11
3.10 Electrical Group	11
3.11 Electronics Group	11
3.12 Furnishings Group	12
4.0 BALANCE STUDIES	13
4.1 Rotor Balance Considerations	13
4.1.1 Analysis of Unsymmetrical Thrust Conditions on an Articulated Rotor System	13
4.1.2 Numerical Analysis of Articulated and Universally Mounted Rotors	16
4.2 Aircraft Balance	21
4.2.1 Aircraft Center-of-Gravity Range Considerations	21
4.2.2 Preliminary Aircraft Balance	24
DISTRIBUTION	25

SYMBOLS

b	Number of blades
c	Blade chord, feet
CF_{HB}	Centrifugal force - blades, lb.
CF_{WT}	Centrifugal force - tip, lb.
c.g.	Center of gravity
D	Blade drag, lb.
D_N	Nacelle drag, lb.
e	Distance from \underline{e} rotation to lead lag hinge ($\$ R$)
F_N	Net engine thrust, lb.
g	Gravitational units (32.2 ft/sec ²)
L_F	Fuselage length, inches
M	Mass units
R	Rotor radius, feet
R_C	W_G/W_G
R_F	W_F/W_G
R_{FT}	W_{FT}/W_G
R_P	W_P/W_G
V_{max}	Maximum speed
W_B	Weight of blade, lb.
W_{BG}	Weight of body group, lb.
W_C	Weight of crew, lb.
W_E	Empty weight less fuel tanks, lb.
W_F	Weight of fuel, lb.
W_{FC}	Weight of flight controls, lb.

SYMBOLS (CONTINUED)

W_{FT}	Weight of fuel tanks, lb.
W_G	Gross weight, lb.
W_H	Weight of hub, lb.
W_{LG}	Weight of landing gear, lb.
W_P	Weight of payload, lb.
W_{PY}	Weight of pylon, lb.
W_{RG}	Weight of rotor group, lb.
W_{STA}	Weight of stabilizer, lb.
W_T	Weight of blade tip, lb.
W_{TR}	Weight of tail rotor, lb.
Z	Moment arms of CF lines of action
δ	Lead lag angle
ϕ_1	W_H/W_G
ϕ_2	W_T/W_B
Ω	Rotor angular velocity, rad/sec.

1.0 SUMMARY

1.1 Weight Studies

The final weight breakdown for the Model 1108 is the result of the parametric study, with the limiting factors involved by the use of actual hardware engines, plus such components on which design layouts have been completed.

The actual weight status of the components comprising the "final" empty weight configuration is as follows:

<u>Rotor Group</u>	(Blades, retention, hub.) Weights calculated from design layouts.
<u>Tail Group</u>	(Tail rotor and stabilizer.) Weights computed by means of statistical equations.
<u>Body Group</u>	(Primary and secondary structure. and provisions for equipment.) Weights computed by means of statistical equations.
<u>Landing Gear Group</u>	(Wheels, struts, mechanism.) Weights computed by means of statistical equations.
<u>Flight Controls Group</u>	(Cockpit controls, linkage rotating and nonrotating items, boost systems and tail rotor controls.) Weights computed by means of statistical equations.
<u>Pylon Group</u>	(Rotor support structure and isolation provisions.) Weights computed by means of statistical equations.
<u>Engine Section Group</u>	(Nacelle fairing, engine mounts, starting system, provisions for oil and fuel lines, oil coolers, inlet and exhaust provisions, engine controls, electrical provisions.) Weights calculated from design layouts.
<u>Engines</u>	Weight of Continental (CAE) Model 357-1 was used for this study.
<u>Fuel System</u>	Weight of fuel system was computed as a fixed percentage of fuel required for the mission.
<u>Auxiliary Power Units</u>	Actual weights of selected units were used. (AiResearch GTCP 100-54)
<u>Gear Boxes and Drives</u>	(Equipment drives and gear boxes.) Weights calculated from design layouts.

<u>Engine Controls</u>	Weight calculated from design layouts.
<u>Starting System</u>	(Lines, valves, and ducts.) Weights calculated from design layouts.
<u>Instrument Group</u>	(Instruments, installation, and wiring and piping.) Weights evaluated by design requirements.
<u>Electrical Group</u>	(Wiring, relays, inverters, batteries, etc.) Weights evaluated by design requirements.
<u>Electronics Group</u>	(Radios, antennas, intercom.) Weights evaluated by design requirements.
<u>Furnishings Group</u>	(Crew seats, belts, reels, pyrotechnics, air conditioning, emergency equipment.) Weights computed by means of statistical equations.

In order to establish the available fuel weight in terms of design parameters, the following relationship may be considered:

$$W_F + W_{FT} = W_G - W_E - W_P - W_C \quad (1)$$

Dividing by W_G , the relationship may be expressed as

$$R_F + R_{FT} = 1 - \phi_1 - R_P - R_C$$

and since $W_{FT} = .10W_F$, then $R_{FT} = .10R_F$

Then
$$R_F = .91(1 - \phi_1 - R_P - R_C)$$

The use of this available fuel weight ratio expression is detailed in the parametric analysis, and a fuel weight is determined for the designated mission. This fuel weight is then substituted into the above relationship, and the fuel tank weight is evaluated therefrom.

In view of the fact that the primary purpose of the subject study was to investigate the feasibility of the tip turbine rotor system concept, much design time was utilized in "sizing" the rotor group. The final decision to employ a four-blade, eight-engine rotor configuration was dictated by the requirement that the Continental 357-1 engine (1,700 lb. thrust) be utilized. Therefore, the major weight study effort was directed toward the satisfactory preliminary design of a four-blade rotor system utilizing the most efficient design techniques and the optimum combination of structural materials available.

After numerous design studies had been conducted, which considered combinations of steel, titanium, and aluminum, and after investigations that

dealt with the most efficient chordwise mass distribution for providing required chordwise EI values, the following blade and hub construction was decided on:

Engine Nacelles

Titanium	{	Engine nacelle skins Engine nacelle fire wall Engine mount installation
Aluminum	{	Center body and supports Splice plates Frames and doors Honeycomb structures Channels and ducts

Blades

Titanium	{	Ribs - retention Inboard and outboard bearing supports - retention Blade retention webs and supports - retention Leading and trailing edge buildup - retention Leading edge nose cap and extrusion - retention Skins and nose plates - retention Trailing edge skins - blade Trailing edge caps - blade Trailing edge extrusion - blade Blade ribs - blade Leading edge skins - blade Root and tip fittings - blade
Steel	{	Leading edge cover - blade Bushings and bearings - retention
Aluminum	{	Trailing edge core - retention Leading edge filler - blade Inner sandwich skin - trailing edge - blade Core - blade

Hub Assembly

Titanium	{	Rotor mast and gimbal ring Bearings - pins and retainers Hub plates Center shaft Retention pins Drag link assembly
Steel	-	Gimbal bearings

1.2 Balance Studies

1.2.1 Rotor Balance Considerations

In selecting a type of rotor system to fulfill the requirements of a heavy-lift helicopter, it is necessary to consider the size of rotor and type of propulsion employed. In the case of the tip turbojet, engines are mounted on the blade tips thereby changing the blade mass characteristics from those of a conventional system.

In a rotor system of the size proposed, complexity of hub and flight controls, and hence weight, is dictated by the number of blades in the system; in this regard then, the rotor with the minimum number of blades will be the optimum. To aid in the selection, a study was conducted regarding the merits of both articulated and universally mounted systems.

In steady flight with constant angular velocity, thrust and centrifugal moments are equal to drag moments, and the blades are in equilibrium in the rotor plane. Theoretically, at this stage there should be no tendency for dissimilarity of blade geometry within the system as each blade has identical thrust, drag and centrifugal forces acting upon it, and the entire system is balanced. However, if one or two engines lost power or failed completely, the effect on the system would be to upset the balance of the rotor, and the blades-engines combination would seek new equilibrium positions.

It is apparent that a rotor system with articulation, free to hinge about a lag axis, would rotate about that axis until a new equilibrium point was reached, which in this case would be the drag moments being balanced by blade centrifugal moments only. In order to determine the magnitude of such a lag angle change, a generalized equation was derived from inputs that were taken from the rotor geometry in a one-blade power loss condition. The equilibrium equation with engines out may be stated as

$$D(3/4R - eR) - CF_{WB}(Z_1) - CF_{WT}(Z_2) = 0 \quad (\text{See Figure 1})$$

This relationship is explained in full in Section 4.0, and the derivation of the generalized equation which expresses the lag angle is discussed.

Using the equation to investigate the effects of a power loss indicates that the articulated system will have a blade angular displacement which produces an in-plane unbalance approximately twelve times greater than the rigid system. The elastic deflection due to one- and two-engines-out conditions on the universally mounted rotor produces in-plane out-of-balance forces of 1,011 pounds and 2,310 pounds, respectively, while the same conditions on the articulated rotor produce forces of 13,715 pounds and 27,431 pounds. By virtue of this, the decision was made to eliminate the articulated system from further study and to adopt a universally mounted rotor system.

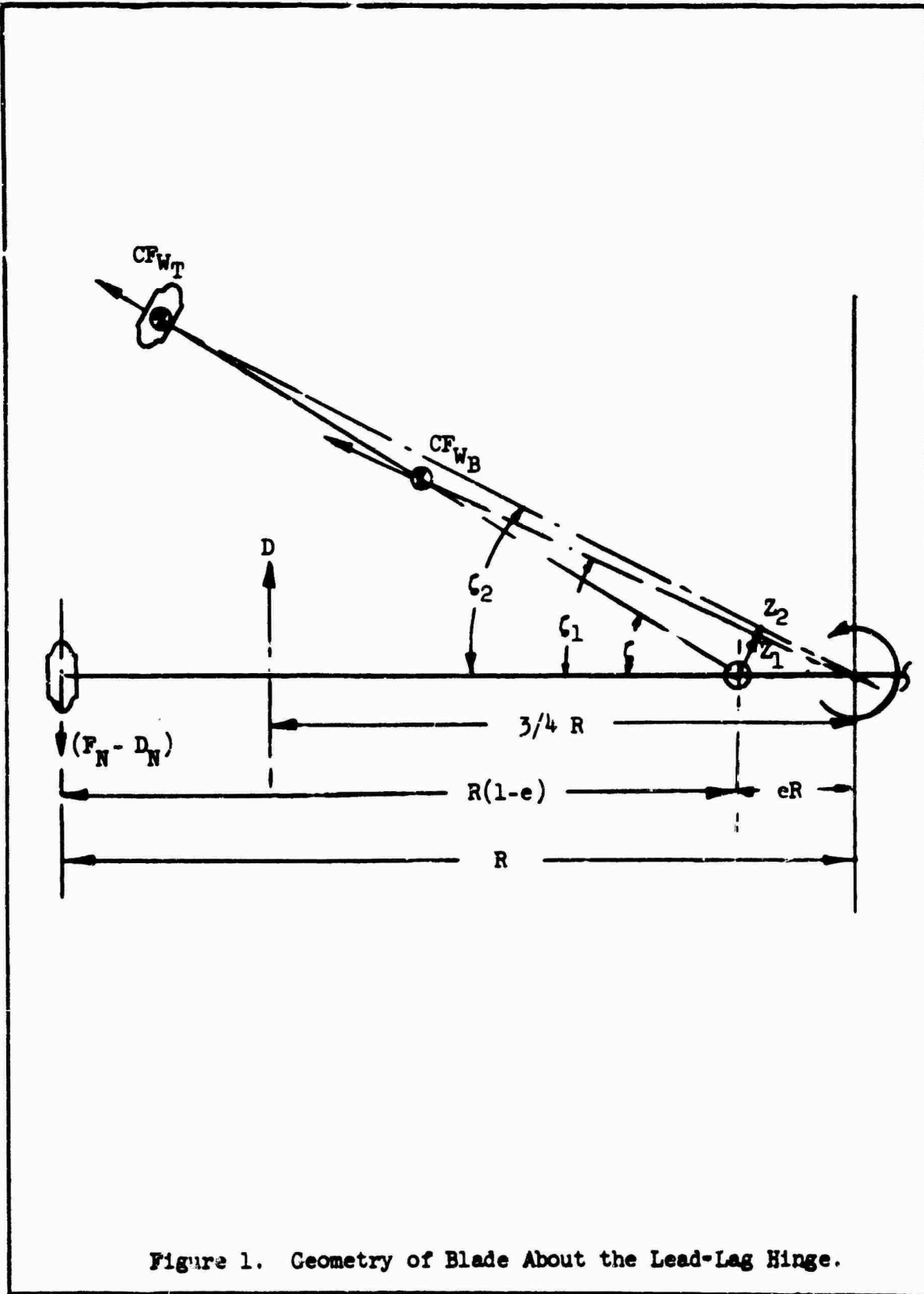

Figure 1. Geometry of Blade About the Lead-Lag Hinge.

1.2.2 Aircraft Balance

Experience at Hiller Aircraft Company has indicated that a helicopter employing a universally mounted rotor is generally at a disadvantage when the center-of-gravity travel is compared to that of a helicopter with an articulated system. However, when a helicopter of the size of the Model 1108 is considered, the linear center-of-gravity travel of a universally mounted rotor system becomes sufficiently extensive to encompass wide variations in loading.

For purposes of balance control, it is considered feasible to design the fuel system center of gravity to coincide with the centerline of rotation, thereby minimizing adverse balance effects due to fuel consumption. The crew weight, being only 1.1 percent of the empty weight, will have a negligible effect on the longitudinal balance and need not be considered further.

In order to eliminate undesirable balance characteristics, the empty weight balance was computed so that the center of gravity in the empty condition was as close to the centerline of rotation as possible.

The total available center-of-gravity range as computed in Section 5.2.1 indicates that 12.7 inches are available for loading variations. It is expected that this range will be expanded with the incorporation of the rotor spring restraint system.

A weight and balance breakdown showing horizontal and vertical centers of gravity has been compiled and indicates the feasibility of the mission loading within the confines of the computed center-of-gravity range.

2.0 CONCLUSIONS

The conclusions to be drawn from Section 1.0 of this report may be expressed as follows.

The aircraft balance, both longitudinally and vertically, should present no loading problems due to the type of carrying procedure that is anticipated. The disposable items of useful load (i.e., fuel, cargo) may be centered on or about the centerline of rotation (Station 240). This load arrangement will enable a minimum of balance control to be required.

The rotor out-of-balance studies, contained in Section 4.1.2, prove conclusively that any articulated system containing a lag hinge will instigate high unbalance forces during an engine-out condition. By virtue of this study, it is shown numerically that the amount of unbalance is approximately twelve times higher than that of a universally mounted rotor; therefore, the latter system was selected as the most acceptable for the heavy lift concept.

3.0 WEIGHT STUDIES

Results obtained from the parametric study of the design mission configuration for a tip turbine powered helicopter using the Continental 357-1 engines are as follows:

Gross weight	71,680 lb.
Tip speed	650.0 f.p.s.
Rotor radius	55.8 ft.
Blade chord	6.5 ft.
V _{max}	125 m.p.h.
Fuselage length	670 in.
Military rated thrust	1,700 lb. per engine

These basic parameters are used to evaluate the various components that make up the empty weight configuration with the exception of the rotor group and certain components of the power plant, instruments, electrical, and electronics groups. Those components actually calculated are detailed in full and are presented in their respective order in the weight breakdown. All weights are given in pounds (lb.).

3.1 Rotor Group

This group includes blades, retention, and hub and has been evaluated from design layouts and component drawings. The weight breakdown of this group is as follows:

<u>Hub and Gimbal Assembly</u>	<u>837 lb.</u>
Gimbal ring	137
Bearings	43
Retainers and seals	35
Hub structure	<u>622</u>
<u>Blade Retention (4 required)</u>	<u>5,714 lb.</u>
Leading edge structure	1,137
Ribs - closure	96
Splice plates	808
Webs	317
Bearings	314
Bearing supports	426
Tie bar assemblies	868
Drag link assembly	508
Retention pin assemblies	586
Bearing trunnions	<u>654</u>

<u>Rotor Blades (4 required)</u>	<u>9,847 lb.</u>
Leading edge structure	5,806
Trailing edge structure	2,468
Sealant and bonding	44
Root webs	66
Splice plates	932
Bearing supports	198
Fittings	185
Ribs, clips, gussets, etc.	<u>148</u>
<u>Total Rotor Group</u>	<u>16,398 lb.</u>

The parametric study required a rotor group relationship that was relevant to the specific type of configuration under consideration. The available statistical weight equation for rotor group is an excellent "sizing tool" for a given gross weight and radius, but it is not sensitive to changes in chord, aspect ratio, number of blades, or solidity. In view of the above limitations, it was decided to evolve a relationship that would correlate closely with current design efforts and would reflect any change in the aforementioned parameters.

The derivation of this equation is contained in the Parametric Design Study, Volume II, and is used therein for solving for "optimum" helicopter configurations or a given set of conditions. The rotor group relationship is as follows:

$$W_{RG} = 500 + 1.8b(.0584 - .0135c + .000958c^2)R^{2.39}(W_T)^{0.36}$$

3.2 Pylon Group Weight 1,731 lb.

This group was determined by statistical means.

$$\begin{aligned} W_{RP} &= .0034 (W_{RG})^{1.354} \\ &= .0034 (509,130) = 1,731 \text{ lb.} \end{aligned}$$

3.3 Tail Group 473 lb.

Tail Rotor. This component was determined by statistical means.

$$\begin{aligned} W_{TR} &= .00022 (W_G)^{1.234} \\ &= .00022 (980,760) = 216 \text{ lb.} \end{aligned}$$

Stabilizer. This component was determined by statistical means.

$$\begin{aligned} W_{STA} &= 1.032 \times 10^{-15} (L_T \times V_{max})^{3.523} \\ &= (1.032 \times 10^{-15})(2.49735 \times 10^{17}) = 257 \text{ lb.} \end{aligned}$$

3.4 Body Group 3,203 lb.

This group was determined by statistical means.

$$\begin{aligned}W_{BG} &= .0875 (L_F \times W_G)^{.594} \\ &= .0875 (36,607) = 3,203 \text{ lb.}\end{aligned}$$

3.5 Landing Gear Group 2,897 lb.

This group was determined by statistical means.

$$\begin{aligned}W_{LG} &= .0158 (W_G)^{1.084} \\ &= .0158 (183,340) = 2,897 \text{ lb.}\end{aligned}$$

3.6 Flight Controls Group 1,434 lb.

This group was determined by statistical means.

$$\begin{aligned}W_{FC} &= .0885 (W_G)^{.867} \\ &= .0885 (16,200) = 1,434 \text{ lb.}\end{aligned}$$

3.7 Engine Section Group 1,359 lb.

This group was calculated from design layouts, based on the over-under engine configuration, and is comprised of the following components:

Engine mounts and fittings	579
Fairings and nacelle	520
Paint and hardware	120
Inlet and exhaust	<u>140</u>

3.8 Propulsion Group 5,539 lb.

This group was calculated from design layouts and actual hardware items.

Engines (8-CAE Model 357-1)	2,920
Cooling system	80
Gear boxes and drives	367
APU units	365
Starting system	140
Engine controls	100
Fuel system	1,608
Rotor mast	<u>275</u>

The instrument, electrical, and electronics groups have been evaluated by design investigation and represent the minimum requirements consistent with the austerity type of configuration proposed.

3.9 Instrument Group 296 lb.

Tachometer generators (11)	33
Tachometer indicators (10)	10
Oil pressure gauges (10)	30
Fuel pressure gauges (10)	30
Oil temperature gauges (10)	20
Airspeed indicator (2)	2
Altimeters (2)	3
Gyro horizon (2)	32
Gyro compass (2)	35
Rate of climb indicators (2)	3
Standby compass (1)	1
Clocks (2)	2
Free air temperature indicator (1)	4
Voltmeters (5)	5
Ammeters (5)	10
Fuel quantity gauges (3)	6
Indicator lights and sensors	10
Panels bracket and installation	<u>40</u>

3.10 Electrical Group 370 lb.

30 KVA generators (2)	140
15 KVA generator (1)	42
Constant speed drive	50
Voltage control regulator (3)	9
Transformer assembly (6)	12
AC power relays (5)	20
Transformer rectifier 100A (2)	20
DC power relays (3)	6
External power receptacle (1)	3
Slip ring assemblies	50
Battery	25
Lights	25
Junction boxes	25
Switches, circuit breakers, etc.	60
Wires, clamps, connectors, etc.	<u>263</u>

3.11 Electronics Group 275 lb.

UHF radio	32
FM radio	25

Identification system	40
ADF	21
TACAN	49
Intercom	10
Radar altimeter	33
Junction box	10
Headsets	5
Wire, clamps, etc.	<u>50</u>

3.12 Furnishings Group

345 lb.

This group was determined by statistical means.

$$\begin{aligned}
 W_{FU} &= .2145 (W_G)^{.660} \\
 &= .2145 (1,600) = 345 \text{ lb.}
 \end{aligned}$$

4.0 BALANCE STUDIES

4.1 Rotor Balance Considerations

When selecting a rotor system for a tip-powered helicopter, consideration must be given to the effects of unsymmetrical thrust due to an engine-out situation. Should this condition tend to lag or deflect a blade sufficiently to cause undesirable balance characteristics, the rotor system so affected could not be utilized.

Unbalance occurs when the c.g. of the rotating mass due to the deflected or lagging blade is not located on the centerline of rotation.

Investigation of the articulated rotor system will show that if one or two engines are out, a blade will lag about the drag hinge to a degree sufficient to offset the rotor c.g. from the rotor mast, thereby generating high in-plane loads induced by the eccentric mass.

With the type of rotor system employed on the Model 1108 aircraft, the unbalanced load that occurs will be due mainly to blade deflection. This unbalanced load has been computed to be less than eight percent of the loads produced in a similar articulated rotor configuration.

4.1.1 Analysis of Unsymmetrical Thrust Conditions on an Articulated Rotor System

Equilibrium about the drag hinge for a single blade is determined by equating the hinge moments to zero. Figure 1 presents the geometry of the blade about the lag hinge.

The angle ζ is defined as the lead-lag angle between the blade mass centroid line passing through the lag hinge and the line passing through the lag hinge and the axis of rotation. The angle ζ is considered positive in the lagging position. The angles ζ_1 and ζ_2 are the angles between no-lag position and the line of action of the blade and tip weight centrifugal forces, respectively. The distances Z_1 and Z_2 are the moment arms from the lag hinge to the respective lines of action of centrifugal forces.

Computing Z_1 and Z_2 in Terms of ζ :

Assuming that the blade centrifugal force acts at one-half the rotor radius, the centrifugal force location with respect to the lead-lag axis may be expressed as $R/2 - eR$. Then:

$$\left(\frac{R}{2} - eR\right) \tan \zeta \approx \frac{R}{2} \tan \zeta_1 \quad \therefore \zeta_1 \approx \zeta(1 - 2e) \quad (\text{for small angles})$$

Thus: $Z_1 \approx eR\zeta_1 \approx eR(1 - 2e)\zeta$

Also, since

$$R \tan \zeta_2 \approx R(1-e) \tan \zeta ; \quad \zeta_2 \approx \zeta(1-e) \quad (\text{for small angles})$$

Thus:
$$Z_2 \approx eR\zeta_2 \approx (eR(1-e)\zeta)$$

The other forces to be considered are blade drag, D , and net engine thrust less nacelle drag, $F_N - D_N$. Blade drag is assumed to act at $3/4R - eR$, and $F_N - D_N$ is assumed to act at $R - eR$. Utilizing these forces and their radial positions, the expression for blade drag may be written as:

$$D = \frac{(F_N - D_N)(R - eR)}{(3/4R - eR)} \quad (2)$$

The moment equation about the lead-lag hinge may now be written as:

$$D\left(\frac{3}{4}R - eR\right) - (F_N - D_N)(R)(1-e) - \frac{W_T}{g} R\Omega^2 [eR(1-e)\zeta] - \frac{W_B}{g} \frac{R\Omega^2}{2} [eR(1-2e)\zeta] = 0$$

Solving for the lead-lag angle ζ , this equation can be rewritten as:

$$\zeta = 2g \frac{\left[D\left(\frac{3}{4} - e\right) - (F_N - D_N)(1-e) \right]}{W_B \Omega^2 eR \left[2\phi_2(1-e) + 1 - 2e \right]} \quad (3)$$

The geometry of an unbalanced, four-blade, articulated rotor system will now be shown. (See Figure 2.)

Employing the arms shown in Figure 2, the c.g. of the unbalanced rotor may be determined.

Assume: $\tan \zeta' = \zeta'$ and $\tan \zeta = \zeta$ (ζ' = lag angle of blade with reduced thrust)

The total moment of the system is:

$$W_{RG} \bar{x} = \sum_{L=1}^9 w_L x_L$$

and
$$W_{RG} = 4(W_B + W_T) + W_H = 4W_B(1 + \phi_2) + W_H$$

Now, determining the system c.g. location, \bar{x} , from the center of rotation:

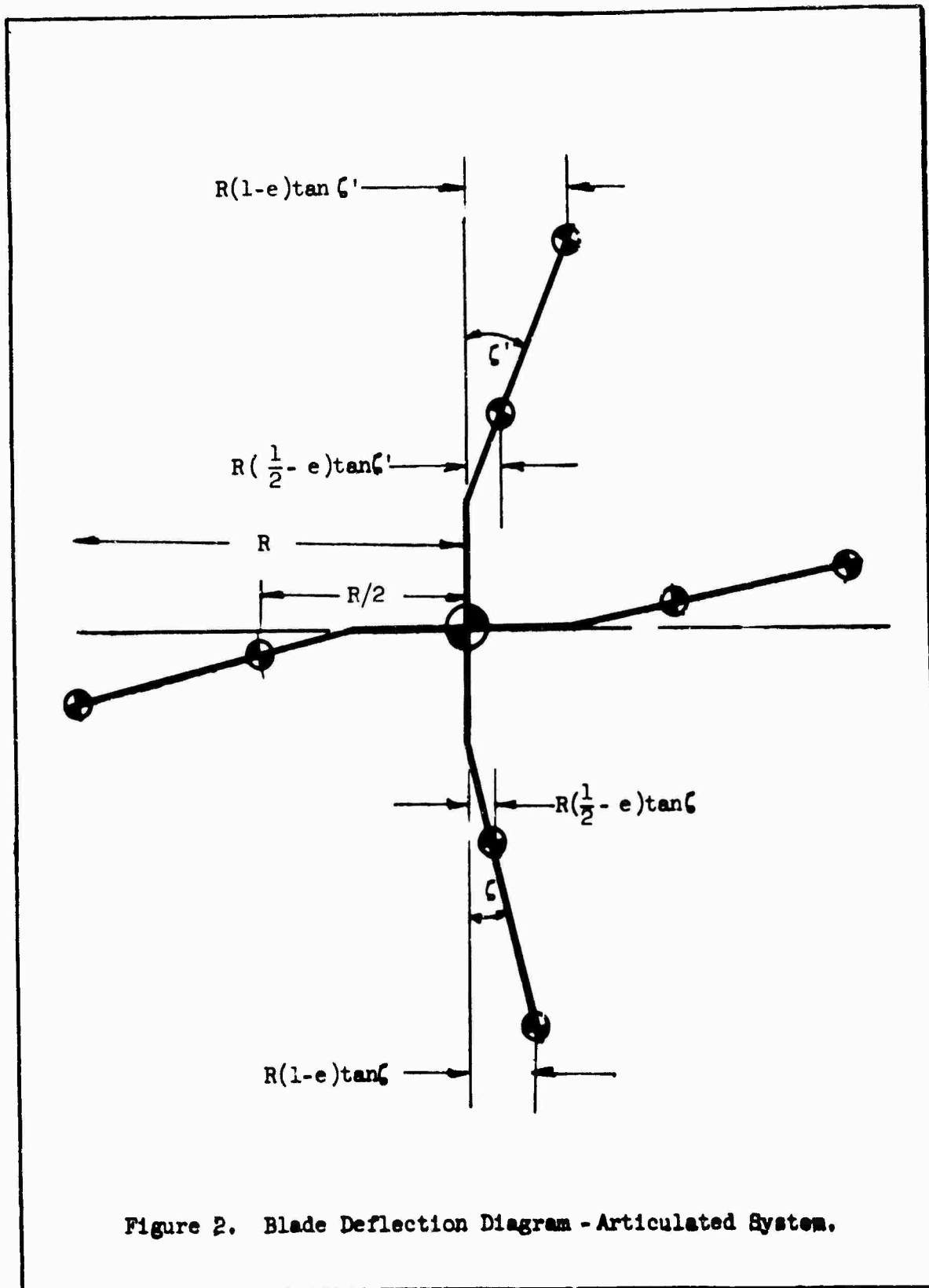

$$\begin{aligned}
\sum_{L=1}^2 w_i x_i &= W_T \left[-R + R(1-e)\zeta + R + R(1-e)\zeta' \right] + \\
& W_B \left[-\frac{R}{2} + R\left(\frac{1}{2} - e\right)\zeta + \frac{R}{2} + R\left(\frac{1}{2} - e\right)\zeta' \right] + W_H(0) \\
&= R(1-e)W_T (\zeta' + \zeta) + R\left(\frac{1}{2} - e\right)W_B (\zeta' + \zeta) \\
&= R(\zeta' + \zeta) \left[W_T(1-e) + W_B\left(\frac{1}{2} - e\right) \right] \\
&= W_{RG} \bar{x}
\end{aligned}$$

And, using the expression for total weight, \bar{x} becomes:

$$\bar{x} = R(\zeta' + \zeta) \frac{W_B \left[\phi_2(1-e) + \left(\frac{1}{2} - e\right) \right]}{4W_B(1+\phi_2) + W_H} \quad (4)$$

Using Equation (4), the in-plane force due to unbalance may be calculated from:

$$\Delta CF = M \bar{x} \Omega^2 \quad (5)$$

4.1.2 Numerical Analysis of Articulated and Universally Mounted Rotors

To determine the effects of the engine-out condition as affected by rotor system type, the following analysis is presented for the unbalance characteristics of the Model 1108 and a similar articulated rotor system helicopter. The following physical characteristics are appropriate for the Model 1108:

Tip speed	592 f.p.s.
Radius	56 ft.
Thrust/engine	1,525 lb.
Nacelle drag	260 lb.
Tip weight	1,200 lb.
Blade weight	2,000 lb.
Hub and retention weight	8,000 lb.
Rotor ϕ to lag hinge, e	0.10R (assumed)

Two engines/blade
Four blades

$$(\text{tip speed}/\text{radius})^2 = \Omega^2 = 111.75$$

$$\phi_2 (W_{\text{tip}}/W_{\text{blade}}) = .6$$

Four-Bladed Articulated System:

Solving for drag, using Equation (2),

$$\begin{aligned} D &= \frac{(F_N - D_N)(1 - e)}{(3/4 - e)} \\ &= \frac{(3050 - 260)(.9)}{.65} \\ &= 3863 \text{ lb.} \end{aligned}$$

Solving for ζ , using Equation (3) for a particular rotor system, the only parameter which will vary is F_N . Thus, Equation (3) may be simplified as follows:

$$\begin{aligned} \zeta &= \frac{2g [D(3/4 - e) - (F_N - D_N)(1 - e)]}{W_B \Omega^2 e R [2\phi_2(1 - e) + 1 - 2e]} \\ \zeta &= \frac{2(32.2) [3863(.75 - .1) - (F_N - 260)(1 - .1)]}{2000(111.75)(.1)(56) [2(.6)(1 - .1) + 1 - 2(.1)]} \\ \zeta &= (7512 - 2.463 F_N) 10^{-5} \end{aligned}$$

Substituting F_N into the above to determine the effects of the engine-out conditions,

At $F_N = 3050 \text{ lb.}, \quad \zeta = 0$

At $F_N = 1525 \text{ lb.}, \quad \zeta = .03756 \text{ radians, or } 2.15 \text{ degrees}$

At $F_N = 0, \quad \zeta = .0751 \text{ radians, or } 4.30 \text{ degrees}$

The amount of unbalance and the increment of centrifugal force are now calculated.

$$\bar{x} = \frac{R(\zeta + \zeta') W_B [2\phi_2(1 - e) + (1/2 - e)]}{4W_B(1 + \phi_2) + W_H}$$

Keeping $(\zeta + \zeta')$ variable, the equation may be written:

$$\bar{x} = \frac{56(\zeta + \zeta') 2000 [.6(1 - .1) + (.5 - .1)]}{4(2000)(1 + .6) + 8000} = 5.06(\zeta + \zeta')$$

For the one-engine-out condition:

$$\bar{x} = 5.06(0 + .03756) = .19 \text{ ft.}$$

$$W_{RG} = 4W_B(1 + \phi_2) + W_H = 4(2,000)(1 + .6) + 8,000 \\ = 20,800$$

$$\Delta CF = M \bar{x} \Omega^2 = \frac{20,800(.19)(111.75)}{32.2} = 13,715 \text{ lb.}$$

For the two-engines-out condition:

$$\bar{x} = 5.06(0 + .0751) = .38 \text{ ft.}$$

$$\Delta CF = \frac{20,800(.38)(111.75)}{32.2} = 27,431 \text{ lb.}$$

Four-Blade, Universally Mounted Rotor System

In the rigid blade, universally mounted rotor system, eccentric unbalance is caused by one or two engines' failing, the amount of the deflection being a function of the chordwise stiffness of the blade.

To illustrate the magnitude of this, Figure 3 shows blade deflection in inches, plotted against blade station, and indicates the maximum effects of the following conditions:

- 1) Full power
- 2) One engine out
- 3) Two engines out

These deflections are calculated from EI values established for the subject helicopter rotor blades.

Figure 4 depicts the rotor geometry that results from the deflections illustrated in Figure 3.

Balance analysis:

One engine out -

$$\frac{W_T(-R + A + A_1 + R) + W_B(-\frac{R}{2} + A_2 + A_3 + \frac{R}{2}) + W_H(0)}{W_{RG}} = \bar{x}$$

or
$$\frac{1,200(.08 + .08) + 2,000(.03 + .02)}{20,800} = \bar{x} = .014 \text{ ft.}$$

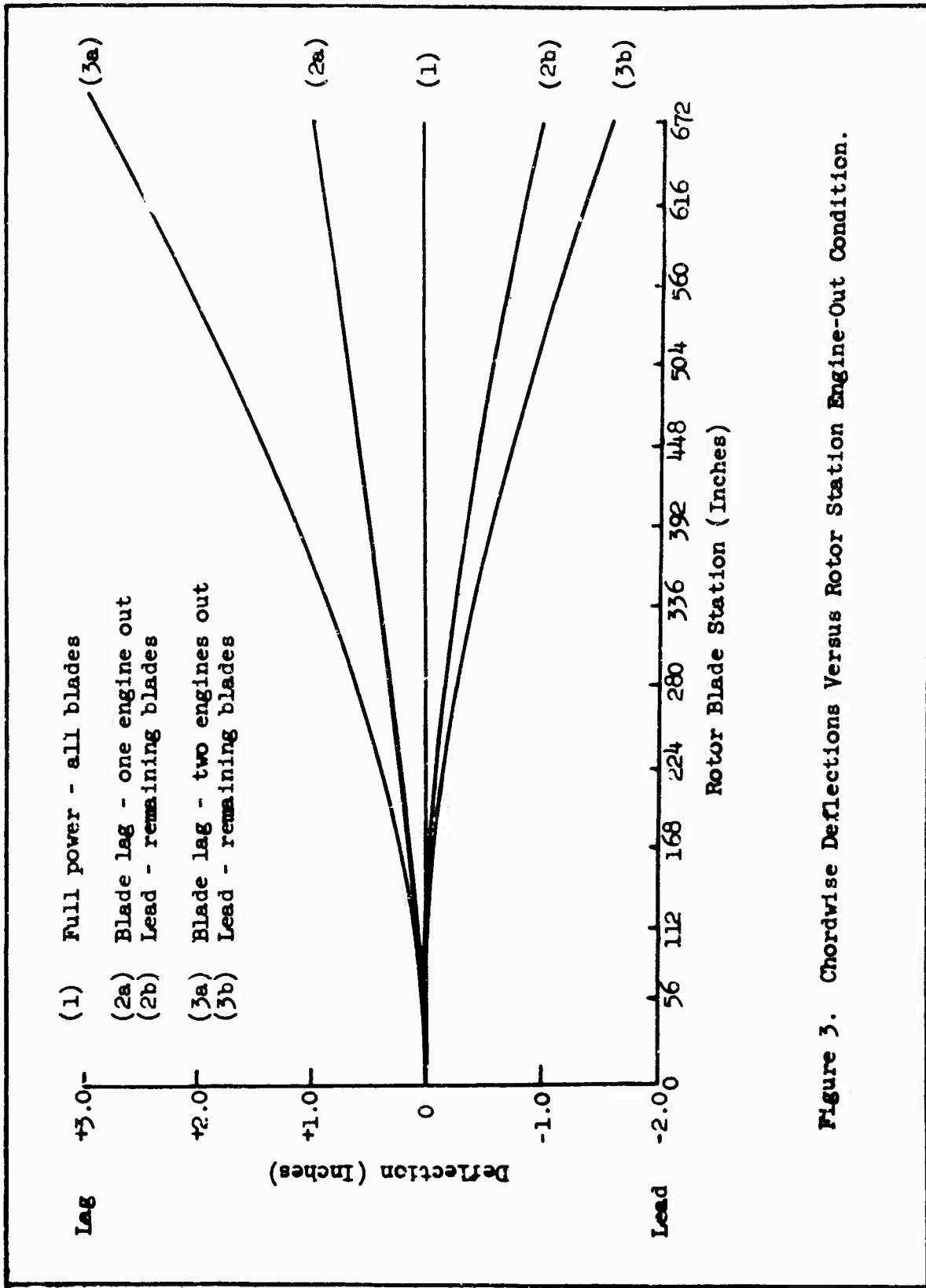
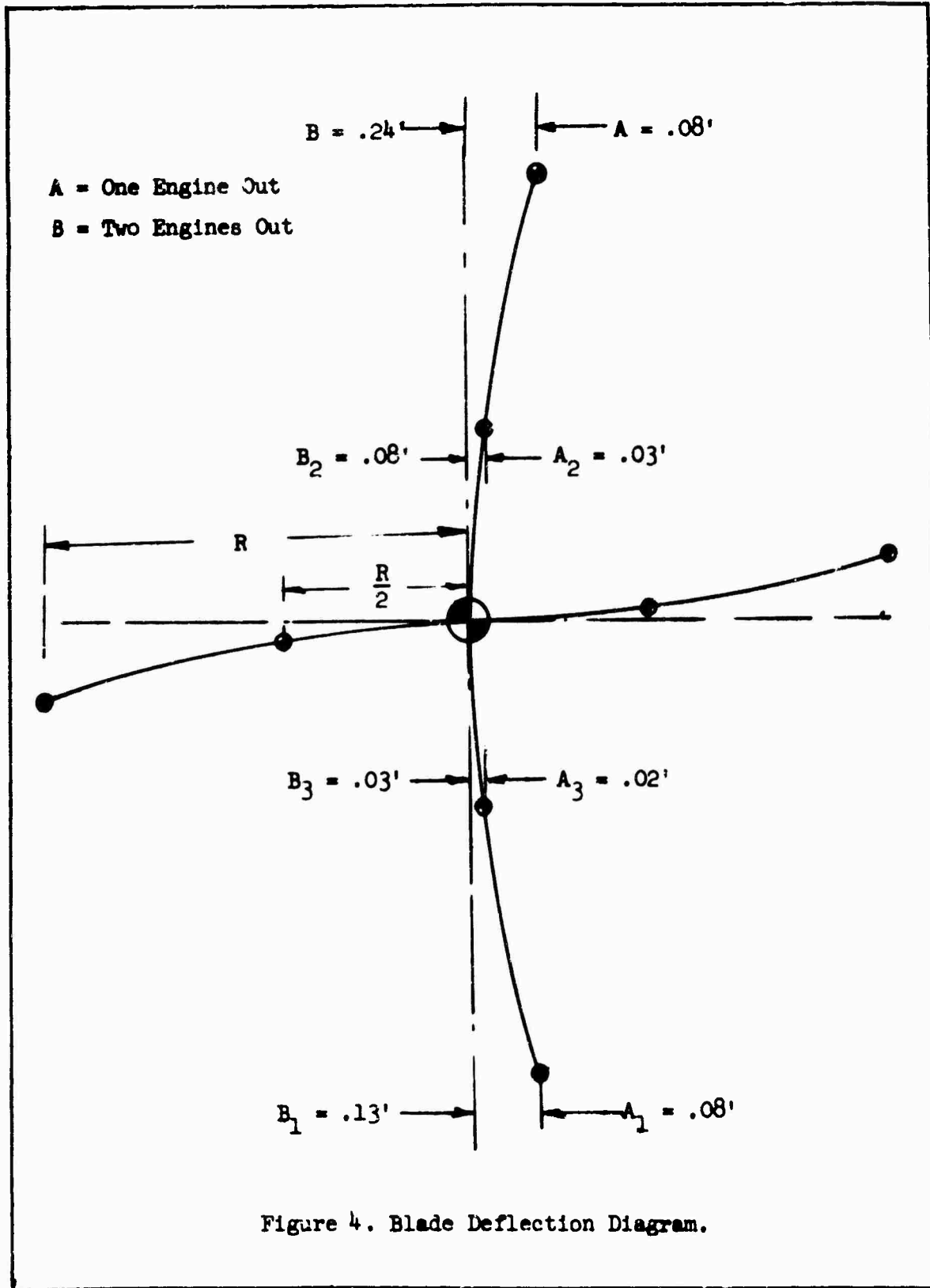

Figure 3. Chordwise Deflections Versus Rotor Station Engine-Out Condition.



$$\Delta CF = \frac{20,800(.014)(111.75)}{32.2} = 1,011 \text{ lb.}$$

Two engines out -

$$\frac{W_T(-R + B + B_1 + R) + W_B(-\frac{R}{2} + B_2 + B_3 + \frac{R}{2}) + W_H(0)}{W_{RG}} = \bar{x}$$

or
$$\frac{1,200(.24 + .13) + 2,000(.08 + .03)}{20,800} = \bar{x} = .032 \text{ ft.}$$

$$\Delta CF = \frac{20,800(.032)(111.75)}{32.2} = 2,310 \text{ lb.}$$

4.2 Aircraft Balance

4.2.1 Aircraft Center-of-Gravity Range Considerations

Experience at Hiller Aircraft Company has indicated that a helicopter employing a universally mounted rotor is generally at a disadvantage when its center-of-gravity travel is compared to that of a helicopter with an articulated rotor system; however, when a helicopter of the size of the Model 1108 is considered, the linear center-of-gravity travel of a universally mounted rotor system becomes sufficiently extensive to encompass all loading variations.

In the case of the subject helicopter, it was determined that the mission payload would be centrally located and its effect on horizontal center of gravity would be small; therefore, a center-of-gravity range was derived by considering the teetering angle of the rotor which moves angularly about the teetering axis a total of 20 degrees from a 1-degree forward tilt vertical.

From experience with existing universally mounted rotor systems, it is known that of this 20-degree travel between stops, approximately 36 minutes is allowed aft of the teetering axis for aft limit boundary (controllability margin in rearward flight), and 4°43' is allowed forward of teetering for forward limit boundary (controllability margin in forward flight).

Using these two angular limits to establish the maximum permissible center-of-gravity range allows a linear relationship to be established as follows:

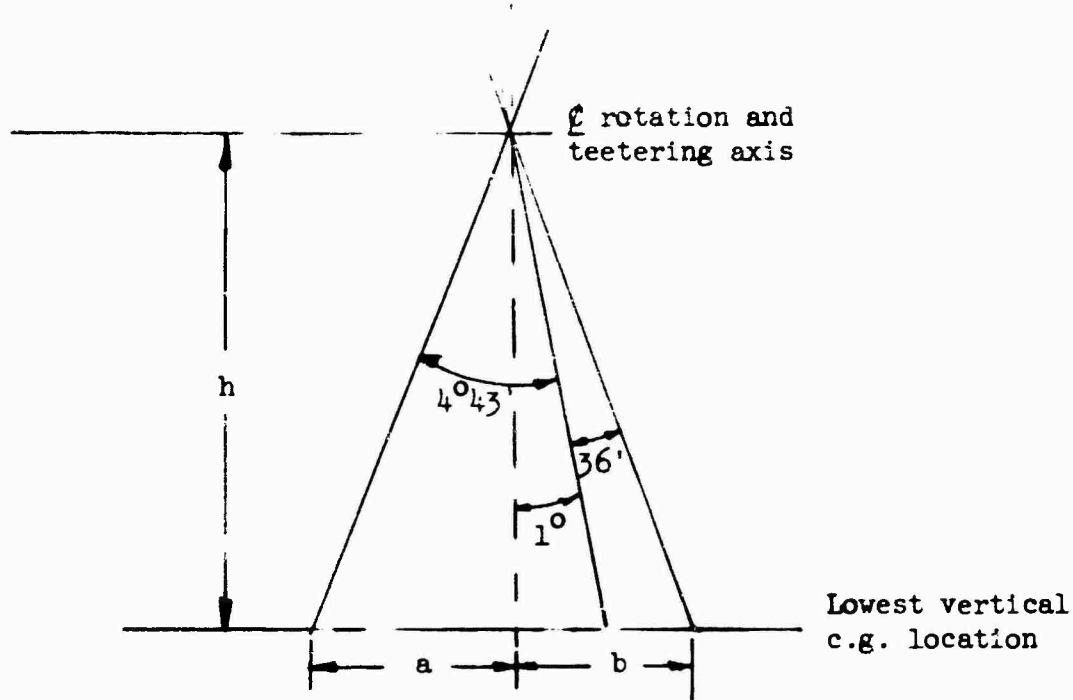

Figure 5. Center-of-Gravity Range.

The distance h is established by determining the vertical center of gravity at gross weight and measuring its distance from the teetering axis.

The distance a is the maximum allowable distance of center-of-gravity movement forward of a vertical drawn through the teetering axis.

The distance b is the maximum allowable distance of center-of-gravity movement aft of a vertical drawn through the teetering axis.

The distance h was determined to be 11.4 feet,

$$\text{then } a = \tan(4.43^\circ - 1^\circ)(11.4) = .06496(11.4) = .74 \text{ ft} \\ = 8.9 \text{ in.}$$

$$\text{and } b = \tan(1^\circ + 36')(11.4) = .02792(11.4) = .32 \text{ ft.} \\ = 3.8 \text{ in.}$$

The centerline of rotation has been established as being at station 20.0 (240.0).

The center-of-gravity limits, therefore, are from (240.0 - 8.9) to (240.0 + 3.8) = Station 231.1 to Station 243.8.

These limits will remain in effect until either proven or disproven by actual flight test.

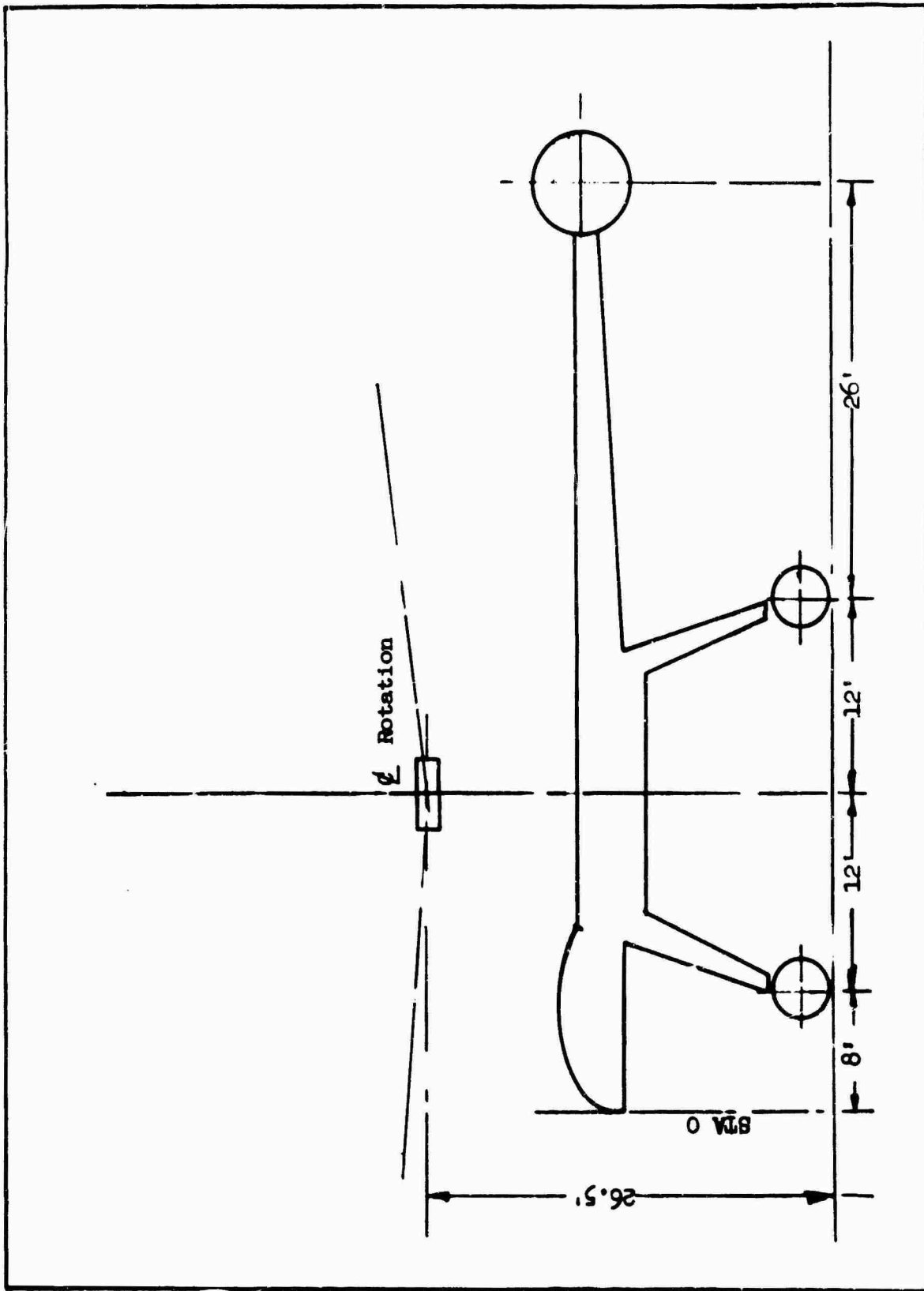

Figure 6. Principal Dimensions

4.2.2 Preliminary Aircraft Balance

<u>Item</u>	<u>W</u>	<u>x</u>	<u>Wx</u>	<u>z</u>	<u>Wz</u>
<u>Rotor Group</u>	<u>16,398</u>	20.0	<u>327,960</u>	27.5	<u>450,950</u>
<u>Tail Group</u>	<u>473</u>		<u>25,592</u>		<u>6,946</u>
Tail rotor	216	58.0	12,528	15.5	3,348
Stabilizer	257	52.0	13,364	14.0	3,598
<u>Body Group</u>	<u>4,934</u>		<u>106,688</u>		<u>84,396</u>
Fuselage	3,203	22.5	72,068	15.0	48,045
Pylon	1,731	20.0	34,620	21.0	36,351
<u>Landing Gear Group</u>	<u>2,897</u>	20.0	<u>57,940</u>	6.0	<u>17,382</u>
<u>Flight Controls Group</u>	<u>1,434</u>	19.0	<u>27,246</u>	22.0	<u>31,548</u>
<u>Engine Section Group</u>	<u>1,359</u>	20.0	<u>27,180</u>	22.0	<u>29,898</u>
<u>Power Plant Group</u>	<u>5,539</u>		<u>119,580</u>		<u>128,626</u>
Engines	2,920	20.0	58,400	27.5	80,300
Cooling system	80	20.0	1,600	27.5	2,200
Gear boxes and drives	367	40.0	14,680	16.0	5,872
A.P.U. units	365	24.0	8,760	16.0	5,840
Starting system	140	20.0	2,800	27.5	3,850
Engine controls	100	20.0	2,000	20.0	2,000
Fuel system	1,292	20.0	25,840	17.0	21,964
Rotor mast	275	20.0	5,500	24.0	6,600
<u>Instrument Group</u>	<u>296</u>	2.5	<u>740</u>	15.5	<u>4,588</u>
<u>Electrical Group</u>	<u>750</u>	20.0	<u>15,000</u>	15.0	<u>11,250</u>
<u>Electronics Group</u>	<u>275</u>	2.5	<u>688</u>	15.0	<u>4,125</u>
<u>Furnishings Group</u>	<u>345</u>	5.0	<u>1,720</u>	15.0	<u>5,160</u>
<u>EMPTY WEIGHT</u>	<u>34,700</u>	(20.5)	<u>710,634</u>	(22.3)	<u>774,869</u>
Crew	400	4.5	1,800	15.5	6,200
Oil	80	20.0	1,600	27.5	2,200
Cargo	24,000	20.0	480,000	15.0	360,000
Fuel	12,924	20.0	258,480	15.0	193,860
<u>GROSS WEIGHT</u>	<u>72,104</u>	(20.1)	<u>1,452,514</u>	(18.5)	<u>1,337,129</u>

Unclassified

Security Classification

DOCUMENT CONTROL DATA - R&D		
<i>(Security classification of title, body of abstract and indexing annotation must be entered when the overall report is classified)</i>		
1. ORIGINATING ACTIVITY (Corporate author) Hiller Aircraft Company, Inc. Palo Alto, California		2a. REPORT SECURITY CLASSIFICATION Unclassified
		2b. GROUP
3. REPORT TITLE Heavy-Lift Tip Turbojet Rotor System, "Weight and Balance Studies", Volume VII		
4. DESCRIPTIVE NOTES (Type of report and inclusive dates)		
5. AUTHOR(S) (Last name, first name, initial)		
6. REPORT DATE October 1965	7a. TOTAL NO. OF PAGES 25	7b. NO. OF REFS
8a. CONTRACT OR GRANT NO. DA 44-177-AMC-25(T)	9a. ORIGINATOR'S REPORT NUMBER(S) USAAVLABS Technical Report 64-68G	
8b. PROJECT NO. c. Task 1M121401D14412	9b. OTHER REPORT NO(S) (Any other numbers that may be assigned this report) Hiller Engineering Report No. 64-47	
10. AVAILABILITY/LIMITATION NOTICES Qualified requesters may obtain copies of this report from DDC. This report has been furnished to the Department of Commerce for sale to the public.		
11. SUPPLEMENTARY NOTES	12. SPONSORING MILITARY ACTIVITY US Army Aviation Materiel Laboratories Fort Eustis, Virginia	
13. ABSTRACT Volume VII of <u>Heavy-Lift Tip Turbojet Rotor System</u> discusses statistical, analytical, and empirical weight analysis methods used to evaluate the empty weight of the helicopter. Blade lag characteristics are also discussed, including an analysis showing blade lag angles with one and two engines inoperative. Included are aircraft balance predictions.		

DD FORM 1473
1 JAN 64

Unclassified

Security Classification

Unclassified

Security Classification

14 KEY WORDS	LINK A		LINK B		LINK C	
	ROLE	WT	ROLE	WT	ROLE	WT
Tip Turbojet Rotor System Weight and Balance						

INSTRUCTIONS

1. **ORIGINATING ACTIVITY:** Enter the name and address of the contractor, subcontractor, grantee, Department of Defense activity or other organization (corporate author) issuing the report.

2a. **REPORT SECURITY CLASSIFICATION:** Enter the overall security classification of the report. Indicate whether "Restricted Data" is included. Marking is to be in accordance with appropriate security regulations.

2b. **GROUP:** Automatic downgrading is specified in DoD Directive 5200.10 and Armed Forces Industrial Manual. Enter the group number. Also, when applicable, show that optional markings have been used for Group 3 and Group 4 as authorized.

3. **REPORT TITLE:** Enter the complete report title in all capital letters. Titles in all cases should be unclassified. If a meaningful title cannot be selected without classification, show title classification in all capitals in parenthesis immediately following the title.

4. **DESCRIPTIVE NOTES:** If appropriate, enter the type of report, e.g., interim, progress, summary, annual, or final. Give the inclusive dates when a specific reporting period is covered.

5. **AUTHOR(S):** Enter the name(s) of author(s) as shown on or in the report. Enter last name, first name, middle initial. If military, show rank and branch of service. The name of the principal author is an absolute minimum requirement.

6. **REPORT DATE:** Enter the date of the report as day, month, year, or month, year. If more than one date appears on the report, use date of publication.

7a. **TOTAL NUMBER OF PAGES:** The total page count should follow normal pagination procedure, i.e., enter the number of pages containing information.

7b. **NUMBER OF REFERENCES:** Enter the total number of references cited in the report.

8a. **CONTRACT OR GRANT NUMBER:** If appropriate, enter the applicable number of the contract or grant under which the report was written.

8b, &c, & 8d. **PROJECT NUMBER:** Enter the appropriate military department identification, such as project number, subproject number, system numbers, task number, etc.

9a. **ORIGINATOR'S REPORT NUMBER(S):** Enter the official report number by which the document will be identified and controlled by the originating activity. This number must be unique to this report.

9b. **OTHER REPORT NUMBER(S):** If the report has been assigned any other report numbers (either by the originator or by the sponsor), also enter this number(s).

10. **AVAILABILITY/LIMITATION NOTICES:** Enter any limitations on further dissemination of the report, other than those imposed by security classification, using standard statements such as:

- (1) "Qualified requesters may obtain copies of this report from DDC."
- (2) "Foreign announcement and dissemination of this report by DDC is not authorized."
- (3) "U. S. Government agencies may obtain copies of this report directly from DDC. Other qualified DDC users shall request through _____."
- (4) "U. S. military agencies may obtain copies of this report directly from DDC. Other qualified users shall request through _____."
- (5) "All distribution of this report is controlled. Qualified DDC users shall request through _____."

If the report has been furnished to the Office of Technical Services, Department of Commerce, for sale to the public, indicate this fact and enter the price, if known.

11. **SUPPLEMENTARY NOTES:** Use for additional explanatory notes.

12. **SPONSORING MILITARY ACTIVITY:** Enter the name of the departmental project office or laboratory sponsoring (paying for) the research and development. Include address.

13. **ABSTRACT:** Enter an abstract giving a brief and factual summary of the document indicative of the report, even though it may also appear elsewhere in the body of the technical report. If additional space is required, a continuation sheet shall be attached.

It is highly desirable that the abstract of classified reports be unclassified. Each paragraph of the abstract shall end with an indication of the military security classification of the information in the paragraph, represented as (TS), (S), (C), or (U).

There is no limitation on the length of the abstract. However, the suggested length is from 150 to 225 words.

14. **KEY WORDS:** Key words are technically meaningful terms or short phrases that characterize a report and may be used as index entries for cataloging the report. Key words must be selected so that no security classification is required. Identifiers, such as equipment model designation, trade name, military project code name, geographic location, may be used as key words but will be followed by an indication of technical context. The assignment of links, rules, and weights is optional.

Unclassified

Security Classification