

AV 629037

COPY NO. 45

TECHNICAL REPORT 3316

DEVELOPMENT OF COLOR MARKER HEADS FOR THE 2.75 - INCH ROCKET

SP6 BERND KLIEM
J. E. ANDREWS, JR.
G. P. BESSEY

FEBRUARY 1966



code 1

CLEARINGHOUSE
FOR FEDERAL SCIENTIFIC AND
TECHNICAL INFORMATION

Hardcopy	Microfilm		
9.60	.75	74	Post

DISTRIBUTION OF THIS DOCUMENT IS UNLIMITED

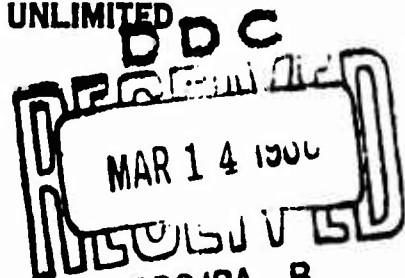

PICATINNY ARSENAL
DOVER, NEW JERSEY

DIC-IRA B

Technical Report 3316

**DEVELOPMENT OF COLOR MARKER HEADS
FOR THE 2.75-INCH ROCKET**

by

Sp6 Bernd Kliem
J. E. Andrews, Jr.
G. P. Bessey

February 1966

Distribution of this document is unlimited

AMCMS Code 4810.16.363112

Pyrotechnics Laboratory
Feltman Research Laboratories
Picatinny Arsenal
Dover, N. J.

ACKNOWLEDGEMENTS

The authors wish to express their appreciation of the untiring efforts which the following individuals contributed to make this project as successful as it was:

Mr. B. Banker

Mr. A. Wronka

TABLE OF CONTENTS

	Page
Object	1
Summary	1
Conclusions and Recommendations	1
Introduction	2
Program History	2
Test Conducted	3
Discussion	3
Appendixes	
A Drawing List	27
B PA-PD-2591, Revision 1 (21 August 1964) plus Amendment 1 and Amendment 2	28
C Engineer Design Test of 2.75 Inch FFAR Color Marker Warheads, XM152 (Red) and XM153 (Yellow)	54
D Engineer Design Test of 2.75 Inch Color Marker Heads, XM152 and T2026	59
E Engineer Design Test of XM153 Color Marker War- head, with XM423 Fuze and Fuze Extension	61
Distribution List	66
Tables	
1 Results of Picatinny Arsenal static tests of color marker warheads for the 2.75-inch rocket	10
2 Results of tests of the XM153 color marker warhead with the XM423 fuze and with and without the 6-inch fuze extension	21
Figures	

Figures		Page
1	Head detail from dwg No. 660853 Mk 1, mod 1, 2.75 inch rocket	24
2	Color marker designs	25
3	Slurry blend loading for 10-pound hardware (dwg P-135046)	26

OBJECT

To develop red and yellow marker warheads for the 2.75-inch rocket system.

SUMMARY

Development of the XM152 red marker warhead and XM153 yellow marker warhead for the 2.75 inch Folding Fin Aircraft Rocket (FFAR) was successfully accomplished in eight weeks. This report presents the results of static tests conducted at Picatinny Arsenal and ballistic tests at other installations during this program and in related investigations.

Because of time limitations, many phases of the investigation could not be carried out as thoroughly as might perhaps have been desired. Nevertheless, a workable item was developed, and a cost savings of \$627,000 (for FY 65) was realized. The ideas tried are presented here together with relevant test results. A sketch of the color marker warhead configuration adopted by the Army and a copy of the accompanying specifications are included in the report.

CONCLUSIONS AND RECOMMENDATIONS

This program proved that the implosion-type warhead has a definite future in the pyrotechnics field. The round seems to have a fuzing problem since ground-impacted warheads do not produce as favorable results as do tree-impacted warheads. It can be concluded that a proximity fuze would be best for this type of warhead.

Much could be said in favor of having special warheads for these special payloads rather than using the standard HE metal parts. A larger payload could be carried and the bursting charge could be greatly reduced.

If the standard XM151 metal parts configuration is to be used, a special investigation should be conducted to determine the effects of the salt in shielding the dye. The slurry blending of dye and salt shows excellent potential. This method should be reviewed and a development program

should be established to find the optimum loading density (which has been found to affect the results drastically).

In future work, care should be taken to conduct sufficient flight tests in conjunction with the static development tests to ensure that the warhead and the fuze are better matched to produce an air burst.

To provide the volume and duration of smoke desired for marking targets, it is recommended that a combination package be developed which will give a large instantaneous cloud and then provide a sustained smoke. This dual package would be very difficult to design economically for the 2.75-inch rocket since the diameter limits the payload. In future development projects, therefore, a larger diameter system should be considered.

INTRODUCTION

The T2026 color marker warhead for the 2.75-inch FFAR was shipped to an overseas agency after an abbreviated loading and testing program at Picatinny Arsenal. These items were found to have many deficiencies in such characteristics as fuzing, cloud color, and cloud persistency. The dye was cast loaded into the standard metal parts of the 6-pound Mk 1, Mod 1, 2.75-inch rocket head, drawing No. 660853 (see Fig 1, p 24). A center cavity was drilled and loaded with explosive to be initiated by a tetryl booster pellet (Fig 2, p 25).

The user, recognizing the deficiencies of this warhead, nevertheless had the item classified Limited Production (LP) and placed an order with Picatinny for 20,000 yellow and 5,000 red rounds.

PROGRAM HISTORY

An order was placed with Picatinny for 5,000 red and 20,000 yellow 2.75-inch color marker warheads. The loading characteristics of the T2026 round were such that Picatinny was forced to look for new techniques by which to fill the order. Some encouraging results were obtained by using an "implosion" design, that is, having the explosive surround the payload. This technique was first advocated by Dr. G. D. Heath of England in 1951.

A program was initiated, to last no longer than 8 weeks, for complete development of the implosion round and preparation for the loading of the ordered items. The loading was carried out on schedule, and various supporting investigations and related programs were carried to completion, as nearly as limited funding would permit.

The 2.75-inch implosion-type head was later adopted by the commodity manager in preference to the explosion-type head (see Fig 1). The implosion-type head is credited with the following characteristics: equal or better fragmentation; a better cloud in shape, color, and consistency with one-third of the dye previously used; the use of dye compositions that have not been reported to be carcinogenic.

TESTS CONDUCTED

More than 250 static tests were conducted at Picatinny Arsenal to determine the feasibility of the "implosion" concept. Table 1 (p 10) shows the many combinations of dye, salt, and explosives that were tried in order to find the optimum combination. Engineering Design (ED) tests of the 2.75-inch FFAR, XM152 and XM153 color marker warheads were conducted in September 1964 and reported in Aberdeen Proving Ground Firing Record 3574 (Appendix C). In addition to the ED tests, a firing demonstration was held at Fort Benning. The results of this demonstration are reported in the "Discussion" section of this report.

DISCUSSION

When the order for the initial 25,000 color marker rounds was received at Picatinny Arsenal, a program had already been initiated by the Pyrotechnics Laboratory to examine the procedure for loading the 2.75-inch FFAR T2026 color marker warhead (explosion-type warhead, see Fig 2).

During examination of the T2026 warhead, various procedures were tried to form a cavity in the dye pellets. This cavity was successfully formed by the use of nylon formers. The explosive is placed into the cavity in a subsequent operation. In static tests of the explosion-type

warheads, however, burning of the dye was observed (see Table 1, p 10). A further attempt to replace the baratol explosive with photoflash burster tubes yielded unsatisfactory results (see Table 1, pp 10 and 17).

Because unsatisfactory results had been obtained with both the explosion-type warhead and the photoflash design in the static tests, a decision was made to investigate an implosion-type color marker warhead design. Basically, the design of an implosion-type color marker warhead consists of cast loading the explosive into an empty warhead and forming a central cavity in the explosive. The dye pellet and salt are then placed in the cavity, with the salt separating the dye from the explosive (see Fig 2).

At first, an attempt was made to cast the salt and dye together in a pellet; however, it was observed during a pilot-lot casting operation that the salt settled out of the dye-salt mixture. This result was undesirable. Table salt of the type sold in grocery stores had been used in the initial mixtures of dye and salt. The next attempt was to replace the table salt with rock salt in the mixing operation. The procedure of melting the dye in a Dow Therm Unit and adding the rock salt under mechanical agitation, however, still did not prevent the salt from settling out. The "slurry" method of dye pelleting was subsequently developed to eliminate the settling-out problem.

The initial design of the implosion-type rounds did not completely eliminate the burning, and an effort was made to shield the dye from the heat of explosion with materials other than salt. The following combinations were tried:

Coolant	Results	Page No.
ZnO powder	Unsatisfactory	10
Stearic acid	Unsatisfactory	10
Aluminum tubing and stearic acid	Unsatisfactory	10
NaCl powder	Satisfactory	10
Plastic tubes	Unsatisfactory	11
Salt in explosive	Unsatisfactory	11, 13
NaCl with stearic acid	Satisfactory	12, 19
Polychloronaphthalene and NaCl	Unsatisfactory	12
Fire clay	Unsatisfactory	12
Rock salt and stearic acid	Satisfactory	12, 14, 17
NaCl in dye	Satisfactory	13
Salt slurry with dye	Satisfactory	18, 19, 20
Zinc and boric acid	Unsatisfactory	18
Uranine, aluminum, and gelatin	Unsatisfactory	18

The results of the static tests conducted at Picatinny Arsenal indicated that sodium chloride (NaCl) and, in particular, rock salt are the best coolants for use in the implosion-type warhead design. The results of the static tests (see Table 1, pp 14 and 15) coupled with the improved pelleting operation influenced the decision to use rock salt instead of the "free running" table salt. Because of time limitations, the salt was not chemically analyzed to determine the reason for the above results. The general contention was that the chemicals put in the table salt for iodization purposes had caused the undesirable smoke cloud effects.

Many of the development ideas were guided by the theory that the explosive had to sublime the dye and disperse the salt, with the dye recondensing on the salt crystals to form the cloud. Some of the concepts that were attempted were:

1. The positions of the explosive and the payload in the shell were reversed (see Table 1, p 11).
2. The salt was introduced into the explosive rather than being made to surround the dye (see Table 1, pp 11 and 13).
3. Production-type high explosive rounds loaded with HB-6 explosive were investigated to determine their suitability for use as vehicles to carry a modified color marker warhead. However, the results of the testing of these rounds were unacceptable (see Table 1, p 19).

Since the most promising test results were obtained from rounds using the implosion concept, a crash development program to make it suitable for production was initiated. An attempt was made to cast the dye sticks for insertion into the center cavity; however, the production problems were immense and a decision was made to pellet the dye and salt separately. This design would place the dye pellet inside of the salt pellet, which in turn would be adjacent to the explosive. A variety of different dye pellet binders were used, such as polychloronaphthalene (PCN) and stearic acid (see Table 1, p 12). The most promising results were obtained from the use of stearic acid conforming to specification PA-PD-2591 (see Appendix B).

Another area that required investigation was the dye content of the warhead. It was evident to engineering personnel that, by increasing the dye content, a larger and possibly improved cloud could be obtained from the detonation. Since the size of the cavity into which the dye pellet was to

be placed could not be changed, attempts were made to increase the dye volume by pressing the pellet under the maximum loading pressure that the loading press would allow; however, the static test results for these pellets were extremely poor, resulting in small clouds with poor color. Hence, the loading pressures for the dye pellets were reduced until a satisfactory smoke cloud was obtained in static tests. Insufficient time precluded investigating the cause and results of the loading pressures (see Table 1, pp 15 and 16). Specification PA-PD-2591, Revision 1, Amendment 2, 18 June 1965, defines the loading densities used in the production rounds.

The pelleting of the dyes was not the only problem. The actual dye content was investigated thoroughly. It was found that the red dye, known chemically as 1-methylaminoanthraquinone, could contain up to 17% dextrin. It is known that the dextrin, which is added as a filler, helps burn up the dye since it is a fuel. This problem was eliminated by using a red dye with no dextrin in it, conforming to ~~Pivatinsky~~ Arsenal Specification PA-PD-382.

At the same time, the yellow dye used in the T2026 head, dimethylaminoazobenzene, was found to be carcinogenic. A new yellow dye had to be found. The amount of testing done to find a new yellow is shown in Table 1, p 15. The best results were obtained by combining indanthrene yellow dye and benzanthrone yellow dye (see Table 1, pp 12 and 14). In addition, various dye combinations were tried during the program, including the use of stabilized red phosphorus, to produce a white cloud (see Table 1, p 20). A special effort was made to produce fluorescent materials for use in the implosion-type round, but without success (see Table 1, pp 13, 18, and 19).

The development program and static tests resulted in the adoption of an implosion-type color marker warhead. The assigned nomenclature for the two warheads are as follows: XM152 red marker warhead and XM153 yellow marker warhead for the 2.75 inch FFAR.

Acceptance tests of the XM152 and XM153 colored marker warheads for the 2.75 inch FFAR were conducted on 21 September 1964. Although the results of these tests were satisfactory, further experimentation was carried out and a new and improved method of blending the salt and the dye was examined. The reason for this experimentation was the continued difficulty that was

encountered in loading the color marker warhead. A wet blend was selected, and the process was named "slurry blending." The static test results were encouraging (see Table 1, pp 18 and 19), and further development was conducted to adapt the test to the 10-pound hardware as shown on Picatinny Arsenal drawing P-135046 (see Fig 3, p 26). This development work was completed during the fourth quarter of FY 65, and static tests at Picatinny were begun on 23 July 1965. The results of this testing are shown in Table 1, pages 19 and 20.

An Engineering Design (ED) test for safety release was next conducted on the implosion-type design, using the XM152 and XM153 color marker warheads. The facilities at Aberdeen Proving Ground, Maryland were used for this purpose. The results of the ED tests are reported in Appendix C.

In addition to the ED tests, a firing demonstration was held at Fort Benning, Georgia on 25 and 26 September 1964. The color marker warheads were fired from a UH-1 helicopter into the target areas. The results of this demonstration were as follows:

1. Twenty-five color marker warheads, 13 XM152 and 12 XM153, were fired at grouped silhouettes and open areas. All 25 warheads functioned properly with no apparent duds. Of the 25, only one XM152 gave a satisfactory red cloud. One other XM152 warhead formed a very light pink cloud upon impact but this level of performance was considered unsatisfactory. Examination of the impact area showed that the XM152 and XM153 warheads had penetrated 8 to 12 inches into the ground before detonating. A considerable amount of dust was formed as a result of this penetration. This dust was seen by observers as contaminating the red and yellow smoke clouds.

2. In addition, a number of high explosive rocket warheads were fired from the helicopters. The clouds produced by these warheads were similar in size to the clouds of the color marker warheads. The clouds were dull grey in color. This observation leads one to believe that dust resulting from the impact is a major contaminant in the color marker smoke cloud.

3. The shrapnel hits on the silhouettes produced by the 2.75-inch warheads (XM152, XM153, and high explosive) were unsatisfactory. Three targets in Group 1 (targets positioned ten meters apart) had only one or two hits from the shrapnel. No targets were hit in Group 2 (targets positioned twenty meters apart).

A series of tests was conducted at Aberdeen Proving Ground between 9 December 1964 and 19 January 1965 for the purpose of comparing the XM152 (implosion design) and the T2026 (explosion design), using both the Mk 178 and XM423E1 fuzes. The procedure used and the results obtained are described in Aberdeen Proving Ground Firing Record R-3612 (see Appendix D).

The tests at Aberdeen Proving Ground and Fort Benning pointed out the still unresolved problems of the color marker warheads. The major problem was that of unsatisfactory color and dirt contamination in the smoke clouds produced by rounds which impacted on open ground or other soft media. It was theorized that the unsatisfactory condition of the smoke clouds was due to the slow functioning of the XM423 fuze. In order to circumvent the slow-acting fuze, a fuze extension was designed for use with the color marker warhead and the XM423 fuze. This fuze extension was placed between the warhead and the fuze (see Fig 3).

A test was conducted at Picatinny Arsenal on 9 March 1965 by the Warheads and Special Projects Laboratory to determine the effect on the smoke cloud of burying the color marker warhead. The warheads were buried to various depths. Unburied warheads were used as controls. The results of the test indicate that the amount of dirt contamination in the smoke cloud is directly proportional to the depth of burial.

A special series of static tests were conducted at Picatinny Arsenal to determine the detonation times of the color marker warheads. The first set of tests was the detonation of the 2.75-inch XM153 FFAR color marker warhead with the XM423 fuze. These rounds were taken from the production line at Picatinny Arsenal. The detonation times in microseconds were 46, 48.2, 47, 48.9, and 49. The next series of tests also involved XM153 warheads with XM423 fuzes, but Composition B explosive was used instead of baratol. The detonation times in microseconds that were obtained in this series of tests were as follows: 35.4, 35.6, 37.2, 34.3, and 34.6. Composition B was used as the explosive for purposes of comparison only. This explosive is not used in color marker warheads because of the tremendous heat that it generates when detonated. This heat would have a deleterious effect on the dye pellets. The third and last series of tests involved the detonation of the standard XM153 warhead with the XM423 fuze and a special 6-inch-long fuze extension that was filled with PB-RDX explosive. The

detonation times in microseconds for these rounds were as follows: 55.8, 55.6, 54.6, 55.0, and 56.1. These times were compared with the impact velocity of the XM153 warhead and the XM423 fuze (without fuze extension). The comparison of the test results proved that the firing train in the round is fast enough to detonate high order before burial of the round can take place.

Arrangements were then made with Aberdeen Proving Ground to ground launch the XM153 color marker warhead with XM423 fuze and special 6-inch fuze extension described previously. The results of this test program are shown in Table () and Appendix E. The test program indicated that the addition of the fuze extension did not increase the size of the cloud nor impact color upon impact against ground, trees, or water. There was considerable dirt contamination in the smoke cloud regardless of whether or not the fuze extension was used. An analysis of the test results showed that a quicker acting fuze is required for point or above-ground initiation. This analysis is based on the personal observation of the Pyrotechnics Laboratory representative present at the test. The official firing record is included in this report as Appendix E.

TABLE 1

Results of Picatinny Arsenal static tests of color marker wa

Round No.	Firing Date	Round Type	Weight of Explosive, lb		Coolant			Dye Type
			Baratol	Tetryl	Type	Weight, lb	Binder	
6W	31 Mar 64	Expl	Note 1		Aluminum tubing			Red
7W	31 Mar 64	Expl	Note 1		Aluminum tubing			Red
8W	31 Mar 64	Expl	Note 1		Aluminum tubing			Red
2W	31 Mar 64	Expl	Note 1		Aluminum tubing			Red
2A	31 Mar 64	Expl	.96	.02	NaCl	.116	None	Red
8A	31 Mar 64	Expl	.85	.02	None	—	Stearic acid	Red
5W	31 Mar 64	Expl	Note 1		Aluminum tubing	—	—	Red
16	31 Mar 64	Impl	1.14	.02	ZnO powder	.09	None	Red
7A	31 Mar 64	Impl	1.18	.02	Aluminum tubing	.04	Stearic acid	Red
1	31 Mar 64	Impl	1.15	.02	NaCl	.056	None	Red
6	31 Mar 64	Impl	1.13	.02	Aluminum foil	NA	None	Red
11	31 Mar 64	Impl	1.13	.02	Aluminum tube	.17	None	Red
7	31 Mar 64	Impl	1.14	.02	Aluminum foil	NA	None	Red
12	31 Mar 64	Impl	1.15	.02	Aluminum tube	.17	None	Red
17	31 Mar 64	Impl	1.15	.02	ZnO powder	.10	None	Red
13	31 Mar 64	Impl	1.15	.02	Aluminum tube	.17	None	Red
18	31 Mar 64	Impl	1.13	.02	ZnO powder	.10	None	Red
3A	31 Mar 64	Expl	.96	.02	NaCl	.12	None	Red
3	31 Mar 64	Impl	1.15	.02	NaCl	.05	None	Red
8	31 Mar 64	Impl	1.13	.02	Aluminum foil	NA	None	Red
6A	31 Mar 64	Expl	1.01	.02	NaCl	.12	None	Red
1A	31 Mar 64	Expl	.98	.02	NaCl	.12	None	Red
2A	31 Mar 64	Expl	.96	.02	NaCl	.11	None	Red
3A	31 Mar 64	Expl	.95	.02	NaCl	.12	None	Red
21	31 Mar 64	Impl	1.14	.02	NaCl, 10 μ	.14	None	Red

Note 1. Photoflash burster tubes.

Red dye is 1-methylaminoanthraquinone supplied by General Aniline & Film Corp.

Round numbers 6, 7, 8, 9, & 10 had pelleted dye (1.245" diam \times 1" high), 6 each per shell, density of 1.10 g/cc. All other dye filler

A

TABLE 1

Static tests of color marker warheads for the 2.75-inch rocket

Binder	Dye		Manufacturing Information	Test Results
	Type	Weight, lb		
	Red			} It was decided after completion of tests that photoflash did not propagate fast enough and also burned the dye
	Red		Red & white smoke	
	Red		White smoke	
	Red		White smoke flash in ctr	
	Red		White smoke cloud	
None	Red	.464		Good red cloud. Bright flash ignition
Stearic acid	Red	.56		Pink. Bright flash ignition, fast dissipation
-	Red	-		White smoke cloud. Flashing in center
None	Red	.26		Dirty pink. Poor cloud, low order detonation
Stearic acid	Red	.19		Dirt cloud. Bright flash in ctr. Very fast dissipation.
None	Red	.204		Small dirty cloud. Sharp detonation
None	Red	.29		Small cloud
None	Red	.26		Fair size cloud in 5 mph wind
None	Red	.29		Red & white smoke. Very fast dissipation, 8 mph wind
None	Red	.25		Pink & white. Flashing in ctr, poor cloud, very fast dissipation
None	Red	.25		Poor cloud, very fast cloud dissipation
None	Red	.25		Fast dissipation, poor cloud, 10-15 mph wind
None	Red	.25		Fast cloud dissipation, 8 mph wind
None	Red	.48		Yellow ctr, fair red. Fast dissipation in 10-15 mph wind
None	Red	.20		White & red color. Fast dissipation
None	Red	.29		Pink with black ctr. Burning took place
None	Red	.48		Good red. Fair cloud, good duration, 10 mph
None	Red	.48		No camera coverage to speak about
None	Red	.47		Red color. Very good cloud, bright flash ignition
None	Red	.48		Red color, yellow ctr. Fast dissipation of fair size cloud in 10-15 mph wind
None	Red	.25		Red, black ctr. Fair cloud

1.10 g/cc. All other dye fillers were cast.

TABLE 1 (cont)

Round No.	Firing Date	Round Type	Weight of Explosive, lb		Coolant				Type
			Baratol	Tetryl	Type	Weight, lb	Binder		
22	31 Mar 64	Impl	1.14	.02	NaCl, 10 μ		.15	None	Red
23	31 Mar 64	Impl	1.15	.02	NaCl, 10 μ		.14	None	Red
4A	23 Apr 64	Expl	.99	.014	NaCl		.11	None	Red
5A	23 Apr 64	Expl	.93	.014	NaCl		.12	None	Red
24	23 Apr 64	Impl	1.13	.014	NaCl, 10 μ		.15	None	Red
25	23 Apr 64	Impl	1.15	.014	NaCl, 10 μ		.15	None	Red
9	23 Apr 64	Impl	1.14	.014	NaCl		.14	See footnotes	Yellow
10	23 Apr 64	Impl	1.13	.014	NaCl		.13	None	Green
4	23 Apr 64	Impl	1.14	.014	NaCl		.14	None	Red
5	23 Apr 64	Impl	1.13	.014	NaCl		.16	None	Red
14	23 Apr 64	Impl	1.13	.014	NaCl		.17	None	Red
15	23 Apr 64	Impl	1.13	.014	NaCl		.16	None	Yellow
19	23 Apr 64	Impl	1.13	.014	NaCl		.16	None	Yellow
20	23 Apr 64	Impl	1.15	.014	NaCl		.15	None	Yellow
S1	7 May 64	Expl	NA	.014	NaCl		NA	None	Red
S2	7 May 64	Expl	NA	.014	NaCl		NA	None	Red
i61	7 May 64	Impl	1.13	.014	NaCl		NA	None	Red
162	7 May 64	Impl	1.13	.014	NaCl		NA	None	Red
163	7 May 64	Impl	1.13	.014	NaCl		NA	None	Red
101	7 May 64	Impl	1.14	.014	NaCl		NA	None	Red
102	7 May 64	Impl	1.14	.014	NaCl		NA	None	Red

Red dye is 1-methylaminoanthraquinone supplied by General Aniline & Film Corp.

Yellow dye is yellow No. 4 (1 part HVT yellow, 2 parts benzanthrone, cast with salt and stearic acid) supplied by North American Dye Co.

Yellow dye in plastic tubes is same mixture as above with no binders added.

Dye pe
shell, id
Green
with st

TABLE 1 (cont)

Binder	Dye		Manufacturing Information	Test Results
	Type	Weight, lb		
None	Red	.25		Good red. Good size cloud
None	Red	.25		Red, black ctr. Good size and consistency
None	Red	.46		Good red. Good size and consistency
None	Red	.48		Red, black ctr. Fair size and consistency
None	Red	.28		Red, black ctr. Excellent consistency
None	Red	.25		Red, small blk ctr. Good red (intense cloud consistency)
See footnotes	Yellow	.07	Cast dye	Yellow, black ctr. Small cloud with poor consistency
None	Green	.10	Cast dye	Good green. Fair size and good consistency
None	Red	.14	Cast dye	Red. Fair size and consistency
None	Red	.08	Dye in plastic tubes	Red & black. Poor results
None	Red	.08	Dye in plastic tubes	Red & black. Poor results
None	Yellow	.06	Dye in plastic tubes	Black & yellow. No cloud
None	Yellow	.06	Dye in plastic tubes	Black & yellow. Small cloud
None	Yellow	.06	Dye in plastic tubes	Black & yellow. Small cloud
None	Red	NA	½ inch tetryl booster	Red. Low order
None	Red	NA	½ inch tetryl booster	Red. Low order
None	Red	NA	Salt in explosive	Burning, poor color. Flashing, low order (no heat shield)
None	Red	NA	Salt in explosive	Burning, poor color. Flashing, low order (no heat shield)
None	Red	NA	Salt in explosive	Burning, poor color. Flashing, low order (no heat shield)
None	Red	NA	½ inch tetryl booster	Poor red, burning. Flashing, low order
None	Red	NA	½ inch tetryl booster	Poor red, burning. Flashing, low order

Dye pellets were pressed when dye was not cast or in powder form. Pellets were 1.245" x 1", 6 each per shell, density of 1.10 g/cc.

id) supplied

Green dye is smoke green No. 4 (7 parts oil green No. 3, 2 parts benzanthrone, 1 part HVT yellow & salt with stearic acid) supplied by North American Dye Co.

TABLE 1 (cont)

Round No.	Firing Date	Round Type	Weight of Explosive, lb		Coolant			Dye Type
			Baratol	Tetryl	Type	Weight, lb	Binder	
103	7 May 64	Impl	1.14	.014	NaCl	NA	None	Red
104	7 May 64	Impl	NA	.032	NaCl, 10 μ	.18	None	Red
105	12 May 64	Impl	1.02	.032	NaCl, 10 μ	.18	None	Red
106	12 May 64	Impl	1.04	.032	NaCl, 10 μ	.18	None	Red
107	12 May 64	Impl	1.04	.03	NaCl, 10 μ	.22	2% stearic acid	Red
108	12 May 64	Impl	1.05	.06	NaCl, 10 μ	.23	2% stearic acid	Red
109	12 May 64	Impl	1.07	.06	NaCl, 10 μ	.20	2% stearic acid	Red
113	12 May 64	Impl	1.06	.06	NaCl, 10 μ	.22	5% stearic acid	Yellow
114	12 May 64	Impl	1.07	.06	NaCl, 10 μ	.22	5% stearic acid	Yellow
115	12 May 64	Impl	1.04	.06	NaCl, 10 μ	.21	5% stearic acid	Yellow
137	12 May 64	Impl	1.07	.06	NaCl, 10 μ	.23	5% stearic acid	Yellow
138	12 May 64	Impl	1.08	.06	NaCl, 10 μ	.24	5% stearic acid	Yellow
139	12 May 64	Impl	1.04	.06	NaCl, 10 μ	.24	5% stearic acid	Yellow
116	12 May 64	Impl	1.03	.06	PCN & NaCl	.29	None	Yellow & SA
117	12 May 64	Impl	1.07	.06	PCN & NaCl	.28	None	Yellow & SA
118	12 May 64	Impl	1.04	.06	PCN & NaCl	.29	None	Yellow & SA
119	12 May 64	Impl	1.03	.06	Fire clay, 10 μ	.27	None	Yellow & SA
120	12 May 64	Impl	1.05	.06	Fire clay, 10 μ	.27	None	Yellow & SA
121	12 May 64	Impl	1.07	.06	Fire clay, 10 μ	.27	None	Yellow & SA
122	12 May 64	Impl	1.06	.06	Rock salt, 10 μ	.20	5% stearic acid	Yellow & SA
123	12 May 64	Impl	1.07	.06	Rock salt, 10 μ	.20	5% stearic acid	Yellow & SA
124	12 May 64	Impl	1.02	.06	Rock salt, 10 μ	.21	5% stearic acid	Yellow & SA
125	12 May 64	Impl	1.04	.06	NaCl, 10 μ	.16	None	Red

Red dye is 1-methylaminoanthraquinone supplied by General Aniline & Film Corp.

Yellow dye is yellow No. 4 (1 part HVT yellow, 2 parts benzanthrone) supplied by General Aniline & Film Corp.

Rock salt is Sterling Retsof FCA rock salt supplied by the International Salt Company, Clarks Summit, Pa.

Dye pellets
1.10 g/cc.
PCN is poly,
SA is stearic

A

TABLE 1 (cont)

Binder	Dye		Manufacturing Information	Test Results
	Type	Weight, lb		
one	Red	NA	½ inch tetryl booster	Poor red. Flashing. Low order
one	Red	.28	Cast dye	
one	Red	.28	Cast dye	Pink. Flashing, poor cloud
one	Red	.28	Cast dye	Pink. Flashing, burning, poor results
¾ stearic acid	Red	.21		Poor red. Flashing, fair size cloud
¾ stearic acid	Red	.21		Fair red. Fair size cloud, good consistency
¾ stearic acid	Red	.22		Good red. Good size cloud, good consistency
¾ stearic acid	Yellow	.19		Good yellow. Good size cloud, good consistency
¾ stearic acid	Yellow	.20		Good yellow. Flashing, good size, fair consistency
¾ stearic acid	Yellow	.19		Good yellow. Good size cloud, good consistency
¾ stearic acid	Yellow	.19	High purity dye	Good yellow. Good size cloud, good consistency
¾ stearic acid	Yellow	.19	High purity dye	Good yellow. Good size cloud, good consistency
¾ stearic acid	Yellow	.19	High purity dye	Good yellow. Good size cloud, good consistency
one	Yellow	.19		Fair yellow. Fair size cloud, fair consistency
one	Yellow	.19	& SA	Good yellow. Fair size cloud, fair consistency
one	Yellow	.19	& SA	Fair yellow. Fair size cloud, fair consistency
one	Yellow	.19	& SA	Poor yellow. Fair size cloud, poor consistency
one	Yellow	.19	& SA	Poor yellow. Poor size cloud, poor consistency
one	Yellow	.19	& SA	Fair yellow. Poor size cloud, poor consistency
¾ stearic acid	Yellow	.19	& SA	Good yellow. Good size cloud, fair consistency
¾ stearic acid	Yellow	.19	& SA	Fair yellow. Flashing, fair size, fair consistency
¾ stearic acid	Yellow	.19	& SA	Fair yellow. Flashing, good size, fair consistency
one	Red	.22	Cast dye	Good red. Good size cloud, fair consistency

Dye pellets were pressed when dye was not cast. Pellets were 1.245" x 1", 6 each per shell, density of 1.10 g/cc.

PCN is polychloronaphthalene.

SA is stearic acid used as binding compound for yellow dye.

TABLE 1 (cont)

Round No.	Firing Date	Round Type	Weight of Explosive, lb		Coolant			
			Baratol	Tetryl	Type	Weight, lb	Binder	Type
126	12 May 64	Impl	1.03	.06	NaCl, 10 μ	.13	None	Red
127	12 May 64	Impl	1.05	.06	NaCl, 10 μ	.17	None	Red
128	12 May 64	Impl	1.06	.06	20% NaCl in dye	.09	5% stearic acid	Red
129	12 May 64	Impl	1.07	.06	20% NaCl in dye	.09	5% stearic acid	Red
130	12 May 64	Impl	1.09	.06	20% NaCl in dye	.08	5% stearic acid	Red
131	12 May 64	Impl	1.07	.06	20% NaCl in dye	.05	5% stearic acid	Yellow
132	12 May 64	Impl	1.07	.06	20% NaCl in dye	.05	5% stearic acid	Yellow
133	12 May 64	Impl	1.05	.06	20% NaCl in dye	.05	5% stearic acid	Yellow
134	12 May 64	Impl	1.04	.06	NaCl, 10 μ	.33	5% stearic acid	Red
135	12 May 64	Impl	1.03	.06	NaCl, 10 μ	.35	5% stearic acid	Red
136	12 May 64	Impl	1.07	.06	NaCl, 10 μ	.34	5% stearic acid	Red
142	12 May 64	Impl	1.03	.06	NaCl, 10 μ	.18	None	Yellow
143	12 May 64	Impl	1.03	.06	NaCl, 10 μ	.19	None	Green
144	12 May 64	Impl	1.00	.06	None	.25	5% stearic acid	Red
145	12 May 64	Impl	1.01	.06	None	.25	5% stearic acid	Red
146	12 May 64	Impl	1.02	.06	None	.25	5% stearic acid	Red
147	12 May 64	Impl	1.04	.06	None	.25	5% stearic acid	Yellow
148	12 May 64	Impl	1.03	.06	None	.25	5% stearic acid	Yellow
149	12 May 64	Impl	1.03	.06	None	.25	5% stearic acid	Yellow
110	12 May 64	Impl	.82	.06	NaCl, 10 μ	.42	Glass vial	Red
111	12 May 64	Impl	1.03	.06	NaCl, 10 μ	.35	Glass vial	Blue
112	12 May 64	Impl	1.07	.06	NaCl, 10 μ	.32	Glass vial	Violet

Round numbers 144-149 loaded with 44% Ba(NO₃)₂, 36% TNT, 20% NaCl.

Dye pellets were used when dye was not cast or in liquid state. Pellet size was 1.25" diam x .75" high, 8 each per shell.

Round numbers 110-112 contained special fluorescent dyes mixed at General Aniline & Film Corp.

Red dye is supplied by American Dye & Pigment Co. high



TABLE 1 (cont)

Binder	Dye		Manufacturing Information	Test Results
	Type	Weight, lb		
None	Red	.24	Cast dye	Fair red. Flashing, good cloud, fair consistency
None	Red	.25	Cast dye	Good red. Flashing, fair cloud, fair consistency
5% stearic acid	Red	.36		Fair red. Flashing, fair cloud, fair consistency
5% stearic acid	Red	.36		Good red. Flashing, good cloud, good consistency
5% stearic acid	Red	.34		Good red. Flashing, good cloud, fair consistency
5% stearic acid	Yellow	.28		Fair yellow. Flashing & burning, fair size, poor consistency
5% stearic acid	Yellow	.29		Poor yellow. Flashing & burning, poor size, poor consistency
5% stearic acid	Yellow	.30		Poor yellow. Flashing & burning, poor size, poor consistency
5% stearic acid	Red	.12		Good red. Flashing, good size, good consistency
5% stearic acid	Red	.11		Good red. Flashing & burning, fair size, good consistency
5% stearic acid	Red	.11		Fair red. Flashing & burning, fair size, fair consistency
None	Yellow	.22	Special cast dye	Poor yellow. Flashing & burning, poor size, poor consistency
None	Green	.23	Special cast dye	Good green. Flashing & burning, good size, good consistency
5% stearic acid	Red	.37	20% NaCl added to baratol	Fair red. Burning, fair size, fair consistency
5% stearic acid	Red	.38	20% NaCl added to baratol	Poor red. Flashing & burning, fair size, poor consistency
5% stearic acid	Red	.38	20% NaCl added to baratol	Fair red. Flashing & burning, fair size, poor consistency
5% stearic acid	Yellow	.36	20% NaCl added to baratol	Fair yellow. Flashing & burning, fair size, poor consistency
5% stearic acid	Yellow	.36	20% NaCl added to baratol	Fair yellow. Flashing & burning, fair size, poor consistency
5% stearic acid	Yellow	.36	20% NaCl added to baratol	Good yellow. Flashing & burning, fair size, poor consistency
Glass vial	Red	.10	Liquid dye	No color. Bluish wisp of poor size and consistency
Glass vial	Blue	.09	Liquid dye	No color. Pink wisp of poor size and consistency
Glass vial	Violet	.09	Liquid dye	No color. Pink wisp of poor size and consistency

Red dye is 1-methylaminoanthraquinone, yellow dye is yellow No. 4 (1 part HVT yellow, 2 parts benzanthrone) supplied by General Aniline & Film Corp.

igh, 8 each

Round numbers 142 & 143 were cast for maximum dye content. These dyes were manufactured by North American Dye Co. using General Aniline & Film Corp. dyes.



TABLE 1 (cont)

Round No.	Firing Date	Round Type	Weight of Explosive, lb		Coolant Type	Weight, lb	Binder	Dye Type
			Baratol	Tetryl				
201	1 June 64	Impl	1.07	.074	Rock salt, 30 mesh	.15	5% stearic acid	Yellow
202	1 June 64	Impl	1.05	.074	Rock salt, 30 mesh	.15	5% stearic acid	Yellow
203	1 June 64	Impl	1.09	.074	Rock salt, 30 mesh	.15	5% stearic acid	Yellow
204	1 June 64	Impl	1.07	.074	Rock salt, 30 mesh	.16	5% stearic acid	Yellow
205	1 June 64	Impl	1.09	.074	Rock salt, 30 mesh	.16	5% stearic acid	Yellow
206	1 June 64	Impl	1.07	.074	Rock salt, 30 mesh	.15	5% stearic acid	Yellow
207	1 June 64	Impl	1.07	.074	Rock salt, 30 mesh	.15	5% stearic acid	Red
208	1 June 64	Impl	1.09	.074	Rock salt, 30 mesh	.16	5% stearic acid	Red
209	1 June 64	Impl	1.10	.074	Rock salt, 30 mesh	.15	5% stearic acid	Red
210	1 June 64	Impl	1.07	.074	Rock salt, 30 mesh	.15	5% stearic acid	Red
211	1 June 64	Impl	1.02	.074	Rock salt, 30 mesh	.14	5% stearic acid	Red
212	1 June 64	Impl	1.07	.074	Rock salt, 30 mesh	.14	5% stearic acid	Red
213	1 June 64	Impl	1.09	.074	Rock salt cyl	.27	5% stearic acid	Yellow 50/50
214	1 June 64	Impl	1.09	.074	Rock salt cyl	.27	5% stearic acid	Yellow 50/50
215	1 June 64	Impl	1.09	.074	Rock salt cyl	.27	5% stearic acid	Yellow 50/50
216	1 June 64	Impl	1.10	.074	Rock salt cyl	.27	5% stearic acid	Yellow HVT
217	1 June 64	Impl	1.09	.074	Rock salt cyl	.27	5% stearic acid	Yellow HVT
218	1 June 64	Impl	1.09	.074	Rock salt cyl	.27	5% stearic acid	Yellow HVT
150A	1 June 64	Impl	1.05	.074	Rock salt cyl	.27	5% stearic acid	PSC yellow No. 7
151A	1 June 64	Impl	1.08	.074	Rock salt cyl	.27	5% stearic acid	PSC yellow No. 7
152A	1 June 64	Impl	1.07	.074	Rock salt cyl	.27	5% stearic acid	PSC yellow No. 7

Red dye is 1-methylaminoanthraquinone of high purity and cast by General Aniline & Film Corp. in conjunction with North American Dye Co.

The cast yellow is 1 part HVT yellow and 1 part benzanthrone supplied by the above manufacturer. Dye was pelleted if cast was not indicated, size: 1.25" x .75", 8 each per shell.

HVT yellow is a vat dye (HVT, high vaporization temperature) supplied by General Aniline & Film Corp.

Salt is Ster
Rock salt e
wafer 1.325
PSC yellow
fluorescent
Yellow 50/50

A

TABLE 1 (cont)

Binder	Dye		Manufacturing Information	Test Results
	Type	Weight, lb		
5% stearic acid	Yellow	.11	Cast dye	Poor yellow. Poor size and consistency
5% stearic acid	Yellow	.11	Cast dye	Fair yellow. Fair size and consistency
5% stearic acid	Yellow	.11	Cast dye	Poor yellow. Poor size and consistency
5% stearic acid	Yellow	.17	Cast dye	Yellow-orange. Good size and consistency
5% stearic acid	Yellow	.20	Cast dye	Red-orange. Good size and consistency
5% stearic acid	Yellow	.20	Cast dye	Red-orange. Good size and consistency
5% stearic acid	Red	.21	Cast dye	Deep red. Good size and consistency
5% stearic acid	Red	.21	Cast dye	Deep red. Good size and fair consistency
5% stearic acid	Red	.21	Cast dye	Good red. Good cloud, some burning
5% stearic acid	Red	.21	Cast dye	Pink. White & red cloud, low order
5% stearic acid	Red	.21	Cast dye	Good red. Good size and consistency
5% stearic acid	Red	.21	Cast dye	Good red. Good size and consistency
5% stearic acid	Yellow	.23		Very deep yellow. Good size and consistency
	50/50			
5% stearic acid	Yellow	.23		Black. Wispy black smoke, high order
	50/50			
5% stearic acid	Yellow	.23		Good yellow. Good size and consistency
	50/50			
5% stearic acid	Yellow	.23		Poor yellow. Black & white wispy smoke, high order
	HVT			
5% stearic acid	Yellow	.23		Poor yellow. Some black, wispy, high order
	HVT			
5% stearic acid	Yellow	.23		Poor yellow. Some black, wispy, high order
	HVT			
5% stearic acid	PSC	.18		Poor yellow. Black & white wispy smoke, high order
	yellow			
	No. 7			
5% stearic acid	PSC	.18		Yellow-orange. Some black, wispy, high order
	yellow			
	No. 7			
5% stearic acid	PSC	.18		Yellow-orange. Some black, wispy, high order
	yellow			
	No. 7			

Reaction with Salt is Sterling Retsof FCA rock salt, granulated through No. 30 mesh screen or as indicated by "cyl." Rock salt cylinders were pressed 1.325" OD x .999" ID x .80" high, 8 each per shell and 1 each salt wafer 1.325" OD x .125" high.

Reaction with PSC yellow No. 7 is a fluorescein dye. Result of detonation gave no indication of the presence of fluorescent smoke.

Reaction with Yellow 50/50 is same composition as the cast yellow but in the form of pellets.

TABLE 1 (cont)

Round No.	Firing Date	Round Type	Weight of Explosive, lb		Coolant			Dye
			Baratol	Tetryl	Type	Weight, lb	Binder	Type
144A	1 June 64	Impl	1.04	.074	Rock salt cyl	.27	5% stearic acid	Sudan orange "
145A	1 June 64	Impl	1.05	.074	Rock salt cyl	.27	5% stearic acid	Sudan orange "
146A	1 June 64	Impl	1.09	.074	Rock salt cyl	.27	5% stearic acid	Sudan orange "
147A	1 June 64	Impl	1.09	.074	Rock salt cyl	.27	5% stearic acid	P-alizarin yello
148A	1 June 64	Impl	1.07	.074	Rock salt cyl	.27	5% stearic acid	P-alizarin yello
149A	1 June 64	Impl	1.08	.074	Rock salt cyl	.27	5% stearic acid	P-alizarin yello
156A	1 June 64	Impl	1.07	.074	Rock salt cyl	.27	5% stearic acid	P-quinoline yell
219	2 June 64	Impl	1.08	.074	Rock salt cyl	.27	5% stearic acid	Red
220	2 June 64	Impl	1.08	.074	Rock salt cyl	.27	5% stearic acid	Red
221	2 June 64	Impl	1.08	.074	Rock salt cyl	.27	5% stearic acid	Red
157A	2 June 64	Impl	1.06	.074	Rock salt cyl	.27	5% stearic acid	P-quinoline yell
158A	2 June 64	Impl	1.06	.074	Rock salt cyl	.27	5% stearic acid	P-quinoline yell
222	2 June 64	Impl	1.08	.074	Rock salt cyl	.27	5% stearic acid	Mixed R & Y pellets
223	2 June 64	Impl	1.09	.074	Rock salt cyl	.27	5% stearic acid	Mixed R & Y pellets
224	2 June 64	Impl	1.08	.074	Rock salt cyl	.27	5% stearic acid	Mixed R & Y pellets
241	2 June 64	Impl	1.90	.074	Rock salt cyl	.39	5% stearic acid	Red
242	2 June 64	Impl	1.89	.074	Rock salt cyl	.39	5% stearic acid	Red
243	2 June 64	Impl	1.88	.074	Rock salt cyl	.39	5% stearic acid	Red
244	2 June 64	Impl	1.86	.074	Rock salt cyl	.39	5% stearic acid	Red
245	2 June 64	Impl	1.84	.074	Rock salt cyl	.39	5% stearic acid	Yellow

Red is 1-methylaminoanthraquinone pressed into pellets at Picatinny Arsenal. Dye supplied by General Aniline & Film Corp.

Yellow is 1 part F supplied by Gen

Salt is Sterling Retsof FCA rock salt pressed into salt cylinders at Picatinny Arsenal.

Quinoline yellow, technicians Laborato

Alizarin yellow-P was pressed into pellets at Picatinny Arsenal. Dye supplied by Picatinny Arsenal Pyrotechnics Laboratory chemists.

Sudan orange "R"

A

TABLE 1 (cont)

Binder	Dye		Manufacturing Information	Test Results
	Type	Weight, lb		
5% stearic acid	Sudan orange "R"	.22		Good orange. Good size, good consistency
5% stearic acid	Sudan orange "R"	.22		Good orange. Fair cloud, fair consistency, high order
5% stearic acid	Sudan orange "R"	.22		Good orange. Good size, good consistency
5% stearic acid	P-alizarin yellow	.20		Poor yellow. Poor cloud, fast dissipation
5% stearic acid	P-alizarin yellow	.20		Poor yellow. Poor cloud, fast dissipation
5% stearic acid	P-alizarin yellow	.20		Poor yellow. Poor cloud, wispy, fast dissipation
5% stearic acid	P-quinoline yellow	.16		Greenish yellow. Fair cloud, fair consistency
5% stearic acid	Red	.23		Good red. Good cloud, rapid dissipation
5% stearic acid	Red	.23		Fair red. Blk ctr, fast dissipation
5% stearic acid	Red	.23		Good red. Good cloud, good consistency
5% stearic acid	P-quinoline yellow	.16		Greenish yellow. Small cloud, fair consistency
5% stearic acid	P-quinoline yellow	.16		Greenish yellow. Small cloud, fair consistency
5% stearic acid	Mixed R & Y pellets	.23		Red orange. Small cloud, poor consistency
5% stearic acid	Mixed R & Y pellets	.23		Orange. Fast dissipation
5% stearic acid	Mixed R & Y pellets	.23		Red orange. Yellow & red separation in cloud
5% stearic acid	Red	.35		Good red. Blk ctr, good cloud
5% stearic acid	Red	.35		Good red. Good cloud, fast dissipation
5% stearic acid	Red	.35		Pinkish red. Blk ctr, wispy cloud
5% stearic acid	Red	.35		Light red. Blk ctr, fast dissipation
5% stearic acid	Yellow	.35		Good yellow. Good cloud, blk ctr

Yellow is 1 part HVT yellow and 1 part benzanthrone yellow, pressed into pellets at Picatinny Arsenal. Dye supplied by General Aniline & Film Corp.

Quinoline yellow-P was pressed into pellets at Picatinny Arsenal. Dye supplied by Picatinny Arsenal Pyrotechnics Laboratory chemists.

Sudan orange "R" supplied by General Aniline & Film Corp., pellets pressed at Picatinny Arsenal.

TABLE 1 (cont)

Round No.	Firing Date	Round Type	Weight of Explosive, lb		Coolant			Dye
			Baratol	Tetryl	Type	Weight, lb	Binder	Type
246	2 June 64	Impl	1.89	.074	Rock salt cyl	.39	5% stearic acid	Yellow
247	2 June 64	Impl	1.85	.074	Rock salt cyl	.39	5% stearic acid	Yellow
248	2 June 64	Impl	1.86	.074	Rock salt cyl	.39	5% stearic acid	Yellow
153A	11 June 64	Impl	1.09	.094	Rock salt cyl	.28	5% stearic acid	Yellow
154A	11 June 64	Impl	1.05	.094	Rock salt cyl	.28	5% stearic acid	Yellow
155A	11 June 64	Impl	1.07	.094	Rock salt cyl	.28	5% stearic acid	Yellow
225	11 June 64	Impl	1.10	.094	Rock salt cyl	.28	5% stearic acid	Yellow
226	11 June 64	Impl	1.09	.094	Rock salt cyl	.28	5% stearic acid	Yellow
228	11 June 64	Impl	1.09	.094	Rock salt cyl	.28	5% stearic acid	Red
229	11 June 64	Impl	1.09	.094	Rock salt cyl	.28	5% stearic acid	Red
230	11 June 64	Impl	1.09	.094	Rock salt cyl	.28	5% stearic acid	Red
231	11 June 64	Impl	1.09	.094	Rock salt cyl	.28	5% stearic acid	Red
234	11 June 64	Impl	1.08	.094	Rock salt cyl	.28	5% stearic acid	Yellow
235	11 June 64	Impl	1.09	.094	Rock salt cyl	.28	5% stearic acid	Yellow
236	11 June 64	Impl	1.09	.094	Rock salt cyl	.28	5% stearic acid	Yellow
237	11 June 64	Impl	1.10	.094	Rock salt cyl	.28	5% stearic acid	Red
238	11 June 64	Impl	1.07	.094	Rock salt cyl	.28	5% stearic acid	Red
1F	11 June 64	Impl	1.09	.094	Rock salt cyl	.28	5% stearic acid	Red
239	11 June 64	Impl	1.09	.094	Rock salt cyl	.28	5% stearic acid	Yellow
240	11 June 64	Impl	1.10	.094	Rock salt cyl	.28	5% stearic acid	Yellow

Red dye is 1-methylaminoanthraquinone pressed into pellets at Picatinny Arsenal. The dye was supplied by General Aniline & Film Corp.

Salt was Sterling Retsof FCA rock salt pressed into salt cylinders at Picatinny Arsenal.

Yellow is

Unless oth

A

TABLE 1 (cont)

Binder	Dye		Manufacturing Information	Test Results
	Type	Weight, lb		
5% stearic acid	Yellow	.35		Very good yellow. Intense cloud, good size
5% stearic acid	Yellow	.35		Good yellow. Good cloud, good consistency
5% stearic acid	Yellow	.35		Good yellow. Good cloud, good consistency
5% stearic acid	Yellow	.18		Good yellow. Intense cloud, good size
5% stearic acid	Yellow	.18		Good yellow. Intense cloud, good size
5% stearic acid	Yellow	.18		Good yellow. Intense cloud, good size
5% stearic acid	Yellow	.23	Dye loading density of 1.27 g/cc	Good yellow. Good size cloud, good consistency, some blk
5% stearic acid	Yellow	.23	Dye loading density of 1.27 g/cc	Good yellow. Fair size cloud, good consistency, some blk
5% stearic acid	Red	.18		Pinkish red. Good cloud, good consistency, off color
5% stearic acid	Red	.18		Pinkish red. Good cloud, good consistency, off color
5% stearic acid	Red	.18		Pinkish red. Good cloud, good consistency, off color
5% stearic acid	Red	.24	Dye loading density of 1.27 g/cc	Pinkish red. Poor cloud, poor consistency, off color
5% stearic acid	Yellow	.19	Dye loading density of 1.15 g/cc	Good yellow. Fair cloud, good consistency
5% stearic acid	Yellow	.19	Dye loading density of 1.15 g/cc	Good yellow. Good cloud, good consistency
5% stearic acid	Yellow	.19	Dye loading density of 1.15 g/cc	Good yellow. Good cloud, good consistency
5% stearic acid	Red	.21	Dye loading density of 1.20 g/cc	Red-orange. Good cloud, good consistency, off color
5% stearic acid	Red	.21	Dye loading density of 1.20 g/cc	Red-orange. Fair cloud, good consistency, off color, some blk
5% stearic acid	Red	.21	Dye loading density of 1.20 g/cc	Pinkish-red. Very good cloud, intense, off color
5% stearic acid	Yellow	.17	Dye loading density of 1.15 g/cc	Good yellow. Good cloud, good consistency
5% stearic acid	Yellow	.17	Dye loading density of 1.15 g/cc	Greenish yellow. Good cloud, fair consistency, some blk, off color

Applied by

Yellow is 1 part HVT yellow and 1 part benzanthrone yellow, pressed into pellets at Picatinny Arsenal. The dye was supplied by General Aniline & Film Corp.

Unless otherwise noted, dye loading density was 1.05 g/cc.

TABLE 1 (cont)

Round No.	Firing Date	Round Type	Weight of Explosive, lb		Coolant			Dye
			Baratol	Tetryl	Type	Weight, lb	Binder	Type
2P	11 June 64	Impl	1.09	.094	Rock salt cyl	.28	5% stearic acid	Yellow
3P	11 June 64	Impl	1.09	.094	Rock salt cyl	.28	5% stearic acid	Red
4P	11 June 64	Impl	1.08	.094	Rock salt cyl	.28	5% stearic acid	Red
5P	11 June 64	Impl	1.09	.094	Rock salt cyl	.28	5% stearic acid	Red
6P	11 June 64	Impl	1.09	.074	Rock salt cyl	.28	5% stearic acid	Yellow
7P	11 June 64	Impl	1.09	.074	Rock salt cyl	.28	5% stearic acid	Yellow
8P	11 June 64	Impl	1.09	.074	Rock salt cyl	.28	5% stearic acid	Yellow
249	11 June 64	Expl	.44	.074	Rock salt	.27	None	Red
250	11 June 64	Expl	.44	.074	Rock salt	.27	None	Red
251	11 June 64	Expl	.44	.074	Rock salt	.27	None	Red
S-5	18 June 64	Expl	.93	.032	Rock salt $10 \pm 3\mu$.18	None	Red
159	18 June 64	Impl	1.07	.074	Rock salt $10 \pm 3\mu$ cyl	.25	2.5% stearic acid	Red
232	18 June 64	Impl	1.07	.074	Rock salt as received from mfr	.27	5% stearic acid	Red
160	18 June 64	Impl	1.05	.074	Rock salt $10 \pm 3\mu$ cyl	.25	2.5% stearic acid	Red
233	18 June 64	Impl	1.06	.074	Rock salt as received from mfr	.27	5% stearic acid	Red
227	18 June 64	Impl	1.07	.074	Rock salt $10 \pm 3\mu$ cyl	.25	2.5% stearic acid	Red
1PR	25 June 64	Expl	Note 1		None	-	None	Red
3PR	25 June 64	Expl	Note 1		NaCl, $10 \pm 3\mu$.01	None	Red
4PR	25 June 64	Expl	Note 1		NaCl, $10 \pm 3\mu$.01	None	Red
9PR	25 June 64	Expl	Note 1		NaCl, $10 \pm 3\mu$.01	None	Red
10PR	25 June 64	Expl	Note 1		NaCl, $10 \pm 3\mu$.01	None	Red
10	25 June 64	Impl	1.09	.074	NaCl cyl	.25	5% stearic acid	Yellow
12	25 June 64	Impl	1.09	.074	NaCl cyl	.25	5% stearic acid	Yellow
13	25 June 64	Impl	1.09	.074	NaCl cyl	.25	5% stearic acid	Yellow

Note 1. Photoflash burster tubes.

Yellow is 1 part HVT yellow and 1 part benzanthrone yellow, pressed into pellets at Picatinny Arsenal. Dye was supplied by General Aniline & Film Corp.

The photoflash bursters for the explosion type rounds were made of 60% potassium chlorate and 40% aluminum.

Red dye is 1 part General Aniline Salt (NaCl) was pressed into

TABLE 1 (cont)

Binder	Dye		Manufacturing Information	Test Results
	Type	Weight, lb		
% stearic acid	Yellow	.17	Dye loading density of 1.15 g/cc	Greenish-yellow. Fair cloud, poor consistency, off color
% stearic acid	Red	.19		Red-orange. Good cloud, good consistency, off color
% stearic acid	Red	.19		Pinkish red. Good cloud, fair consistency, off color
% stearic acid	Red	.19		Intense-pinkish red. Good cloud, very good consistency, off color
% stearic acid	Yellow	.18	Dye loading density of 1.15 g/cc	Good yellow. Low cloud, some blk, not intense
% stearic acid	Yellow	.18	Dye loading density of 1.15 g/cc	Good yellow. Good cloud, intense yellow
% stearic acid	Yellow	.18	Dye loading density of 1.15 g/cc	Good yellow. Good cloud, intense yellow
lone	Red	.58		Pinkish-red. Fair cloud, some blk, good consistency
lone	Red	.58		Pinkish-red. Good cloud, good consistency
lone	Red	.58		Pinkish-red. Good cloud, poor consistency
lone	Red	NA	Cast dye	Good red. Good cloud size, fair consistency
.5% stearic acid	Red	.21		Deep red. Good cloud size, good consistency
% stearic acid	Red	.21		Good red. Good cloud, deep center consistency
.5% stearic acid	Red	.21		Good red. Good cloud, good consistency
% stearic acid	Red	.21		Good red. Good cloud, fair consistency
.5% stearic acid	Red	.21		Excellent red. Good cloud, very good consistency
lone	Red	.69	Cast dye	White with red. Good cloud size, burning, almost completely white
lone	Red	.69	Cast dye	White with red. Good cloud size, burning, almost completely white
lone	Red	.70	Cast dye	White with red. Good cloud size, burning, almost completely white
lone	Red	.70	Cast dye	White with red. Good cloud size, burning, almost completely white
lone	Red	.70	Cast dye	White with red. Good cloud size, burning, almost completely white
% stearic acid	Yellow	.205	75/25 HVT/benzanthrone	Excellent yellow. Good cloud size, intense color
% stearic acid	Yellow	.205	75/25 HVT/benzanthrone high purity	Good yellow. Good cloud size, good color intensity
% stearic acid	Yellow	.206	50/50 low/high purity benzanthrone	Fair yellow. Good cloud size, fair color intensity

Red dye is 1-methylaminoanthraquinone pressed into pellets at Picatinny Arsenal. Dye was supplied by General Aniline & Film Corp.

Salt (NaCl) was commercial type available in grocery stores. Rock salt was Sterling Retsof FCA rock salt pressed into salt cylinders at Picatinny Arsenal

l. Dye was
luminum.

TABLE 1 (cont)

Round No.	Firing Date	Round Type	Weight of Explosive, lb		Coolant			Dye	
			Baratol	Tetryl	Type	Weight, lb	Binder		Type
5 rounds each	21 Sept 64	Impl	Standard configuration, acceptance tests of lot 48-3						
5 rounds each	21 Sept 64	Impl	Standard configuration, acceptance tests of lot 49-2						
2 rounds each	21 Sept 64	Impl	Standard configuration, acceptance tests of lot 48-2						
3 rounds each	21 Sept 64	Impl	Standard configuration, acceptance tests of lot 48-2						
40	1 Oct 64	Impl	1.09	.074	Salt slurry with dye	NA		Yellow	
44	1 Oct 64	Impl	1.09	.074	Salt slurry with dye	NA		Yellow	
41	1 Oct 64	Impl	1.07	.074	Salt slurry with dye	.24		Red	
42	1 Oct 64	Impl	1.08	.074	Salt slurry with dye	.24		Red	
43	1 Oct 64	Impl	1.10	.074	Salt slurry with dye	.24		Red	
9	1 Oct 64	Impl	1.08	.074	Zinc-boric acid cyl	.29		Note 1	
11	1 Oct 64	Impl	1.08	.074	Zinc-boric acid cyl	.29		Note 1	
21	1 Oct 64	Impl	1.10	.074	Zinc-boric acid cyl	.29		Note 2	
22	1 Oct 64	Impl	1.08	.074	Zinc-boric acid cyl	.29		Note 2	
23	1 Oct 64	Impl	1.09	.074	Zinc-boric acid cyl	.29		Note 2	
24	1 Oct 64	Impl	1.09	.074	Salt	NA	NA	Smoke green	
25	1 Oct 64	Impl	1.09	.074	Salt	NA	NA	Smoke green	
26	1 Oct 64	Impl	1.11	.074	Salt	.24	NA	Smoke green	
27	1 Oct 64	Impl	1.08	.074	Uranine-aluminum gelatine mixture				
28	1 Oct 64	Impl	1.13	.074	Uranine-aluminum gelatine mixture				
29	1 Oct 64	Impl	1.09	.074	Salt	.23	NA	Blue	
30	1 Oct 64	Impl	1.08	.074	Salt	.23	NA	Blue & yellow	
31	1 Oct 64	Impl	1.09	.074	Salt	.23	NA	Blue & green	
32	1 Oct 64	Impl	1.10	.074	Stabilized red phosphorus				
33	1 Oct 64	Impl	1.09	.074	Stabilized red phosphorus				
34	1 Oct 64	Impl	1.07	.074	Stabilized red phosphorus				

Note 1. Fuzed boric acid and fluorescein.

Note 2. Unfuzed boric acid and fluorescein.

Dyes were pelleted whenever feasible.

Salt used was Sterling Retsof FCA rock salt pressed into cylinders at Picatinny Arsenal.

Yellow dye
Green blue
The blue-
and placed
For standar

A

TABLE 1 (cont)

Binder	Dye		Manufacturing Information.	Test Results
	Type	Weight, lb		
			Red. Accepted	
			Yellow. Accepted	
			Red. Accepted	
			Red. Accepted	
	Yellow	NA	Yellow. Good size cloud, fair consistency, good color	
	Yellow	NA	Yellow. Good size cloud, fair consistency, good color	
	Red	.19	Red. Good size cloud, good consistency	
	Red	.19	Red. Good size cloud, good consistency	
	Red	.19	Red. Good size cloud, good consistency	
	Note 1	.21	Green stain on steel plates at firing point	
	Note 1	.21	Green stain on steel plates at firing point	
	Note 2	.19	White & wispy smoke. Unacceptable, no fluorescein smoke	
	Note 2	.19	White & wispy smoke. Unacceptable, no fluorescein smoke	
	Note 2	.19	White & wispy smoke. Unacceptable, no fluorescein smoke	
NA	Smoke green	.23	Purple. Poor cloud, wispy, wrong color	
NA	Smoke green	.23	Blue-grey with purple. Poor results, unacceptable	
NA	Smoke green	.19	Blue-grey. Poor cloud, y, wrong color	
		.52	No color. No stain on ground, not acceptable	
		.49	No color. No stain on ground, not acceptable	
NA	Blue	.17	Violet. Unacceptable, wrong color	
NA	Blue & yellow	.19	Blue-grey. Unacceptable results	
NA	Blue & green	.20	Blue-grey. Unacceptable results	
		NA	White cloud. Good size, good intensity	
		NA	White cloud. Good size, good intensity	
		NA	White cloud. Good size, good intensity	

Yellow dye is 75% HVT yellow and 25% benzanthrone yellow, pressed into pellets at Picatinny Arsenal.

Green blue is type of dye used in hand grenades. This dye was used in round 31.

The blue-green and blue-yellow dyes were made into 4 blue pellets and 3 yellow or green pellets, respectively, and placed alternately in the respective warhead.

For standard configuration see loading drawings of XM152, XM153.

TABLE 1 (cont)

Round No.	Firing Date	Round Type	Weight of Explosive, lb		Coolant			Dye	
			Baratol	Tetryl	Type	Weight, lb	Binder	Type	Weight
38	1 Oct 64	Impl	1.09	.074	Calcium sulfate-bismuth subcarbonate mix.				.2
39	1 Oct 64	Impl	1.09	.074	Calcium sulfate-bismuth subcarbonate mix.				.2
45	1 Oct 64	Impl	1.07	.074	Red dye and salt brine mixture-no pellets				.0
46	1 Oct 64	Impl	1.08	.074	Red dye and salt brine mixture-no pellets				.0
48	1 Oct 64	Impl	1.07	.074	Red dye slurry & 50% salt				NA
49	1 Oct 64	Impl	1.07	.074	Red dye slurry & 50% salt				NA
50	1 Oct 64	Impl	1.07	.074	Red dye slurry & 50% salt				NA
301	11 Oct 64	Impl	.75 H-6	.074	Salt by slurry blend		.08	Red	.31
302	11 Oct 64	Impl	.75 H-6	.074	Salt by slurry blend		.08	Red	.31
303	11 Oct 64	Impl	.75 H-6	.074	NaCl cyl		.24	Stearic acid	.20
304	11 Oct 64	Impl	.75 H-6	.074	NaCl cyl		.24	Stearic acid	.20
305	11 Oct 64	Impl	.75 H-6	.074	NaCl cyl		.24	Stearic acid	.20
306	11 Oct 64	Impl	.75 H-6	.074	Salt by slurry blend		.08	Yellow	.31
307	11 Oct 64	Impl	.75 H-6	.074	Salt by slurry blend		.08	Yellow	.31
308	11 Oct 64	Impl	.75 H-6	.074	NaCl cyl		.24	Stearic acid	.20
309	11 Oct 64	Impl	.75 H-6	.074	NaCl cyl		.24	Stearic acid	.20
310	11 Oct 64	Impl	.75 H-6	.074	NaCl cyl		.24	Stearic acid	.20
311	11 Oct 64	Impl	1.86	.074	NaCl cyl		.41	Stearic acid	.34
312	11 Oct 64	Impl	1.86	.074	NaCl cyl		.41	Stearic acid	.34
313	11 Oct 64	Impl	1.87	.074	Salt by slurry blend		.12	Red	.50
314	11 Oct 64	Impl	1.83	.074	Salt by slurry blend		.12	Red	.50
315	11 Oct 64	Impl	1.88	.074	NaCl cyl		.41	Yellow	.35
316	11 Oct 64	Impl	1.88	.074	NaCl cyl		.41	Yellow	.35
317	11 Oct 64	Impl	1.87	.074	Salt by slurry blend		.12	Yellow	.50
318	11 Oct 64	Impl	1.86	.074	Salt by slurry blend		.12	Yellow	.50
319	11 Oct 64	Impl	1.86	.074	NaCl cyl		.41	Blue	.36
320	11 Oct 64	Impl	1.85	.074	NaCl cyl		.41	Blue	.36

Calcium sulfate-bismuth subcarbonate/flare composition was obtained by alternating pellets of each material using six flare pellets (total weight: 24 lb) and five sulfate-carbonate pellets.

Red dye is 1-methylaminoanthraquinone, 80% red and 20% salt for slurry blend; 95% red and 5% stearic acid by pelleting method (salt cylinders are separate).

Rounds 301 thru 310 used HBX-6 explosive. This is shown in the table as H-6.

Yellow used in rounds 315 and 316 is 75% HVT yellow (indanthrene), 20% benzanthrone, and 5% stearic acid pressed into pellets at Picatinny Arsenal

Yellow used in rounds 317 and 318 is 60% HVT yellow (indanthrene), 20% benzanthrone, and 20% salt by slurry blending.

For pelleting pressure and/or configuration, see loading drawings of the XM 152 and XM153.

The salt slurry was used in an effort to

Yellow dye composition was used by method, and 6

Red, used in rounds 315 and 316 at Picatinny Arsenal.

Blue used in rounds 319 and 320 at Picatinny Arsenal.

Salt used was sodium chloride from Picatinny Arsenal.



TABLE 1 (cont)

Binder	Dye		Manufacturing Information	Test Results
	Type	Weight, lb		
		.26		Shiny solid particles were found in vicinity
		.27		Shiny solid particles were found in vicinity
		.055		Red. Good size, color and consistency for amount of dye used
		.055		Red. Good size, color and consistency for amount of dye used
		NA		Red. Good all around results
		NA		Red. Good all around results
		NA		Red. Good all around results
	Red	.31		Lt red. Poor results due to explosive
	Red	.31		Pinkish red. Poor results due to explosive
stearic acid	Red	.20		Lt red. Fair cloud size and consistency
stearic acid	Red	.20		Red. Fair cloud size and consistency
stearic acid	Red	.20		Lt red. Fair cloud size and consistency
	Yellow	.31		Pale yellow. Poor results due to high explosive
	Yellow	.31		Pale yellow. Poor almost no color
stearic acid	Yellow	.20		White smoke. Poor, only white smoke resulted
stearic acid	Yellow	.20		White smoke. Poor, only white smoke resulted
stearic acid	Yellow	.20		White smoke. Poor, only white smoke resulted
stearic acid	Red	.34		Red. Good color, size, and consistency
stearic acid	Red	.34		Red. Good color, size, and consistency
	Red	.50		Red. Good color, size, and consistency
	Red	.50		Good red. Very good size, consistency, and color
	Yellow	.35		Yellow. Good size and consistency
	Yellow	.35		Yellow. Good size and consistency
	Yellow	.50		Very good yellow. Very good size and consistency
	Yellow	.50		Good yellow. Good size and consistency
	Blue	.36		Blue. Good size, consistency, and color
	Blue	.36		Blue. Good size, consistency, and color

material using The salt slurry (rounds 48-50) was devised by Mr. Wronka and Mr. Banker of the Picatinny Arsenal Loading Branch in an effort to cool more of the dye during explosive combustion and therefore kept it from burning.

acid by Yellow dye consists of 75% HVT yellow (indanthrene), 20% benzanthrone, 5% stearic acid in the pelleting method, and 60% HVT yellow (indanthrene), 20% benzanthrone yellow, and 20% salt in the slurry blending.

acid Red, used in round 314, is 80% 1-methylaminoanthraquinone and 20% salt by slurry blending at Picatinny Arsenal.

by slurry Blue used in rounds 319 and 320 is 85% 1-4 dimethylaminoanthraquinone, and 5% stearic acid pressed into pellets at Picatinny Arsenal.

Salt used was Sterling Retsof FCA rock salt. The NaCl cyl indicates salt cylinders pressed at Picatinny Arsenal.

TABLE 1 (cont)

Round No.	Firing Date	Round Type	Weight of Explosive, lb		Coolant			Dye	
			Baratol	Tetryl	Type	Weight, lb	Binder	Type	Weight, lb
321	11 Oct 64	Impl	1.91	.074	Salt by slurry blend	.12		Blue	.50
322	11 Oct 64	Impl	1.88	.074	Salt by slurry blend	.12		Blue	.50
323	11 Oct 64	Impl	1.90	.074	NaCl cyl	.41		Blue	.35
324	11 Oct 64	Impl	1.86	.074	NaCl cyl	.41		Blue	.35
325	11 Oct 64	Impl	1.87	.074	NaCl cyl	.41		Green	.36
326	11 Oct 64	Impl	1.88	.074	NaCl cyl	.41		Green	.36
327	11 Oct 64	Impl	1.84	.074	Salt by slurry blend	.12		Green	.50
328	11 Oct 64	Impl	1.87	.074	Salt by slurry blend	.12		Green	.50
329	11 Oct 64	Impl	1.85	.074	NaCl cyl	.41		Green	.36
330	11 Oct 64	Impl	1.88	.074	NaCl cyl	.41		Green	.36
331	22 Jan 65	Impl	1.76	.074	Salt surrounding al cylinder			Red phosphorus	.61
332	22 Jan 65	Impl	1.85	.074	Salt surrounding al cylinder			Red phosphorus	.60
333	22 Jan 65	Impl	1.86	.074	Salt surrounding al cylinder			Red phosphorus	.61
334	22 Jan 65	Impl	1.88	.074	Salt surrounding al cylinder			Red phosphorus	.61
335	22 Jan 65	Impl	1.92	.074	Salt by slurry blend			Red	.44
336	22 Jan 65	Impl	1.83	.074	Salt by slurry blend			Red	.44
337	22 Jan 65	Impl	1.88	.074	Salt by slurry blend			Red	.44
338	22 Jan 65	Impl	1.84	.074	Salt by slurry blend			Yellow	.45
339	22 Jan 65	Impl	1.82	.074	Salt by slurry blend			Yellow	.45
340	22 Jan 65	Impl	1.83	.074	Salt by slurry blend			Yellow	.45
341	22 Jan 65	Impl	1.81	.074	Salt by slurry blend			Blue	.45
342	22 Jan 65	Impl	1.70	.074	Salt by slurry blend			Blue	.45
343	22 Jan 65	Impl	1.80	.074	Salt by slurry blend			Blue	.45
344	22 Jan 65	Impl	1.83	.074	Salt by slurry blend			Green	.45
345	22 Jan 65	Impl	1.81	.074	Salt by slurry blend			Green	.45

Blue used in rounds 321 and 322 is 80% 1-4 dimethylaminoanthraquinone and 20% salt by slurry blending.

Blue used in rounds 323 and 324 is 95% diparatoluodine anthraquinone and 5% stearic acid pressed into pellets at Picatinny Arsenal.

Green used in rounds 325 and 326 is 65% 1-4 dimethylaminoanthraquinone, 26% HVT yellow (indanthrene), 9% benzanthrone yellow, and 5% stearic acid pressed into pellets at Picatinny Arsenal.

Green used in rounds 327 and 328 is 56% benzanthrone yellow, 24% 1-4 dimethylaminoanthraquinone, and 20% salt by slurry blending.

Green used in rounds 329 and 330 is 65% diparatoluodine anthraquinone, 26% HVT yellow (indanthrene), 3% benzanthrone yellow, and 5% stearic acid pressed into pellets at Picatinny Arsenal.

For pelleting pressure and/or configuration, see loading drawings of the 2.75-inch color marker warhead, XM152 or XM153.

Red phosphorus dye is

Red dye is 77.5%/20%

Yellow dye is 57.5%/Arsenal.

Blue dye used in rounds into pellets at Picatinny

Green dye used in rounds quinone/indanthrene/

Salt used was Sterling

A

TABLE 1 (cont)

Dye			
Type	Weight, lb	Manufacturing Information	Type
Blue	.50	Blue. Good size, consistency, and color	
Blue	.50	Blue. Good size, consistency, and color	
Blue	.35	Green-blue. Fair size, consistency, and color	
Blue	.35	Green-blue. Fair size, consistency, and color	
Green	.36	Blue-green. Good size, consistency, and color	
Green	.36	Blue-green. Good size, consistency, and color	
Green	.50	Blue-green. Fair size, consistency, and color	
Green	.50	Blue-green. Fair size, consistency, and color	
Green	.36	Dirty green. Fair size, consistency, and color	
Green	.36	Dirty green. Fair size, consistency, and color	
Red phosphorus	.61	Good white. Very good size, consistency, and color	
Red phosphorus	.60	Good white. Very good size, consistency, and color	
Red phosphorus	.61	Good white. Very good size, consistency, and color	
Red phosphorus	.61	Good white. Smaller size, good consistency and color	
Red	.44	Average red. Small size cloud with duration of 10 sec	
Red	.44	Dull red. Small size cloud with duration of 10 sec	
Red	.44	Pink. Average size cloud with duration of 20 sec	
Yellow	.45	Good yellow. Good size cloud with duration of 12 sec	
Yellow	.45	Good yellow. Good size cloud with duration of 15 sec	
Yellow	.45	Good yellow. Good size cloud with duration of 15 sec	
Blue	.45	Blue with yellow trace. Good size cloud but had yellow tinge	
Blue	.45	Good blue. Good size cloud with duration of 15 sec	
Blue	.45	Good blue. Good size cloud with duration of 10 sec	
Green	.45	Good green. Good size cloud with duration of 30 sec	
Green	.45	Good green. Good size cloud with duration of 30 sec	

- fig. Red phosphorus dye is 90%/10% of stabilized red phosphorus/laminac loaded in aluminum cylinder at Picatinny Arsenal.
- Red dye is 77.5%/20%/2.5% of methylaminoanthraquinone/salt/carbowax 4000 pressed into pellets at Picatinny Arsenal.
- Yellow dye is 57.5%/20%/5% of 1-4 dimethylaminoanthraquinone/salt/carbowax 4000 pressed into pellets at Picatinny Arsenal.
- Blue dye used in rounds 341, 342, and 343 is 75%/20%/5% of 1-4 dimethylaminoanthraquinone/salt/carbowax 4000 pressed into pellets at Picatinny Arsenal.
- Green dye used in rounds 344 and 345 is 42.75%/20%/18.75% 13.5%/5% of benzanthrone salt/1-4 dimethylaminoanthraquinone/indanthrene/carbowax 4000 pressed into pellets at Picatinny Arsenal.
- Salt used was Sterling Retsof FCA rock salt. The NaCl cyl indicates salt cylinders pressed at Picatinny Arsenal.

TABLE 2

Results of tests of the XM153 color marker warhead with the XM423 fuze and with and without the 6-inch fuze extension^{a,b}

Round No.	Launch Angle, deg	Range, yd	Fuze Extension	Comments
GROUND IMPACT				
1	6	3300	No	Helicopter 400 ft above impact. Good yellow with dirt, 10-sec duration
2	6	3400	No	Same as above; cloud one-half yellow, one-half dirt
3	6	2000	No	Same as above; cloud one-half yellow, one-half dirt (short range)
4	10	1000	Yes	Cloud too far away to see
5	10	4200	Yes	Poor cloud
6	10	3400	Yes	Pale yellow, some dirt, 10-sec duration
7	6	2500	No	Average yellow
8	6	2000	No	Average yellow, lot of dirt
9	6	2000	No	Poor yellow, lot of dirt
10	10	4000	Yes	Average yellow, lot of dirt
11	10	4600	Yes	Average yellow, small cloud
12	10	4000	Yes	Pale yellow
13	6	1000	No	Good yellow but cloud far away
14	6	3000	No	Dull yellow, lot of dirt
15	6	4000	No	Good yellow, some dirt
16	10	4100	Yes	No cloud, round buried
17	10	4200	Yes	Very little yellow, lot of dirt
18	10	3800	Yes	Average yellow, lot of dirt

^aObserver: P. Bessey, Picatinny Arsenal. Range engineer: G. Murray.

^bWind: 7-15 knots. Range: ground and tree impact, Bomb Field, Aberdeen. Weather: clear with some haze and light clouds. Camera coverage: 16 mm documentary from 4000 yard tower, and from helicopter at 500-ft altitude.

TABLE 2 (cont)

Round No.	Launch Angle, deg	Range, yd	Fuze Extension	Comments
19	6	3600	No	Dull yellow, lot of dirt
20	6	2000	No	Pale yellow, lot of dirt
21	6	2200	No	Poor yellow, lot of dirt
22	10	3500	Yes	Good yellow, some dirt
23	10	3600	Yes	No smoke cloud, just dirt (gray color)
24	10	4200	Yes	One-third of cloud yellow, two-thirds dirt
25	6	3000	No	Some yellow, most dirt
26	6	3600	No	Very little yellow, looks burned (some brown)
27	6	3000	No	Poor cloud, mostly dirt
28	10	4200	Yes	Dark brown color on impact, no yellow cloud
29	10	4400	Yes	Dark brown color on impact, cloud one-third yellow, two-thirds dirt
30	10	3500	Yes	No yellow smoke cloud, round seemed to bury

TREE IMPACT

31	6	3700	No	Excellent yellow, good cloud
32	6	2500	No	Mostly dirt, some yellow. Missed trees, hit in field
33	6	2500	No	Mostly dirt, some yellow. Missed trees, hit in field
34	10	3800	Yes	Good yellow, good cloud
35	10	3400	Yes	Average yellow. Missed trees, hit in field
36	10	4000	Yes	Average yellow. Missed trees, hit in field
37	6	3500	No	Pale yellow, hit in field

TABLE 2 (cont)

Round No.	Launch Angle, deg	Range, yd	Fuze Extension	Comments
38	6	1000	No	Poor shot, pale yellow
39	6	1000	No	Poor shot, pale yellow
40	10	NA	Yes	Dud
41	10	NA	Yes	Did not see cloud
42	10	3000	Yes	Good cloud

WATER IMPACT^a

43	6	2800	No	No cloud
44	6	2600	No	A small cloud, no duration
45	6	3000	No	Small cloud, detonated under water
46	10	4000	Yes	No cloud
47	10	2000	Yes	Small cloud
48	10	1000	Yes	Short shot
49	6	500	No	Short shot
50	6	2000	No	Average cloud, 10 sec
51	6	2000	No	Small cloud, detonated under water
52	10	4000	Yes	Small cloud
53	10	2400	Yes	No cloud
54	10	3200	Yes	No cloud, detonated under water
55	6	NA	No	Short round
56	6	2000	No	Small cloud
57	6	1000	No	Short, small cloud
58	10	1000	Yes	Short, small cloud
59	10	1000	Yes	Short, small cloud
60	10	2000	Yes	No cloud

^aWind: 3 knots. Range: Bush River from Wilson Point to Sandy Point, Edgewood Arsenal. Weather: hazy with little or no sunlight. Camera coverage: 16 mm documentary, from Sandy Point (4000 yd), and from helicopter (500 ft).

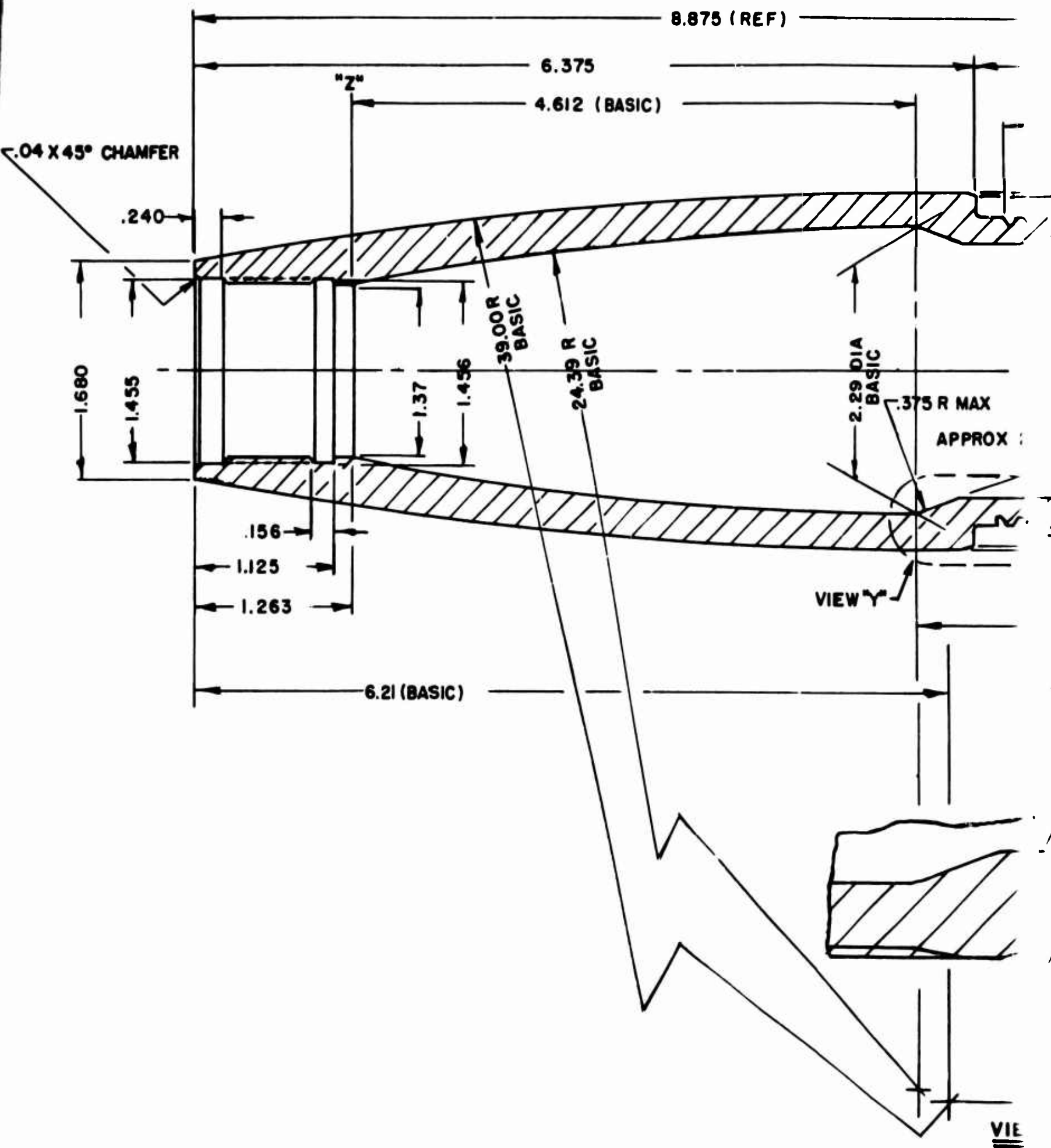
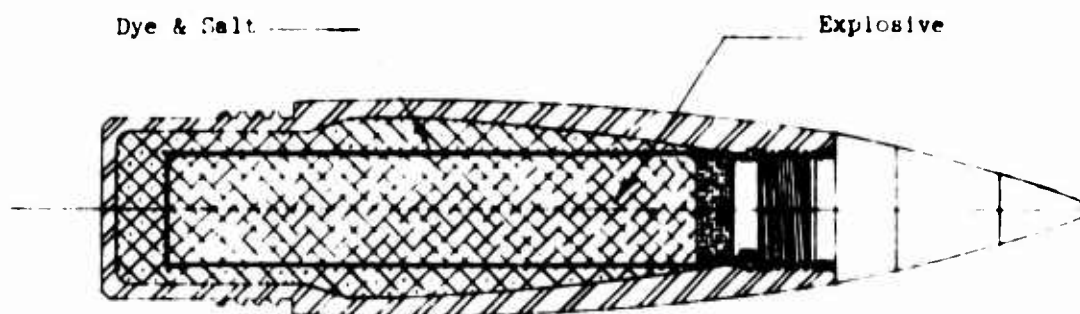

Fig 1 Head detail from dwg No. 660853 Mk 1, mod 1, 2.75 inch rocket

A

VIE



2.75 Inch 67/33 Baratol Spotting Charge T2026 Explosion Design

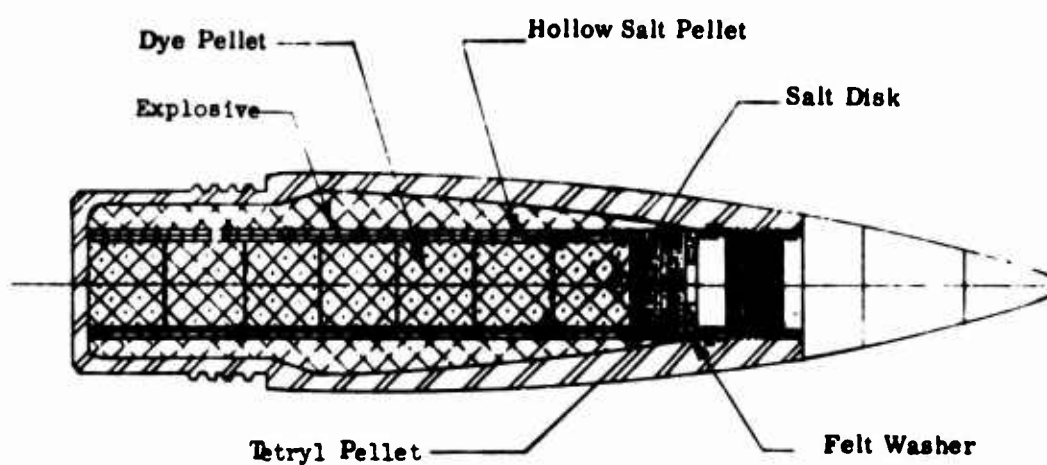

2.75 Inch Warhead, H.E; Red Marker XM152 Implosion Design
 2.75 Inch Warhead, H.E; Yellow Marker XM153 Implosion Design

Fig 2 Color marker designs

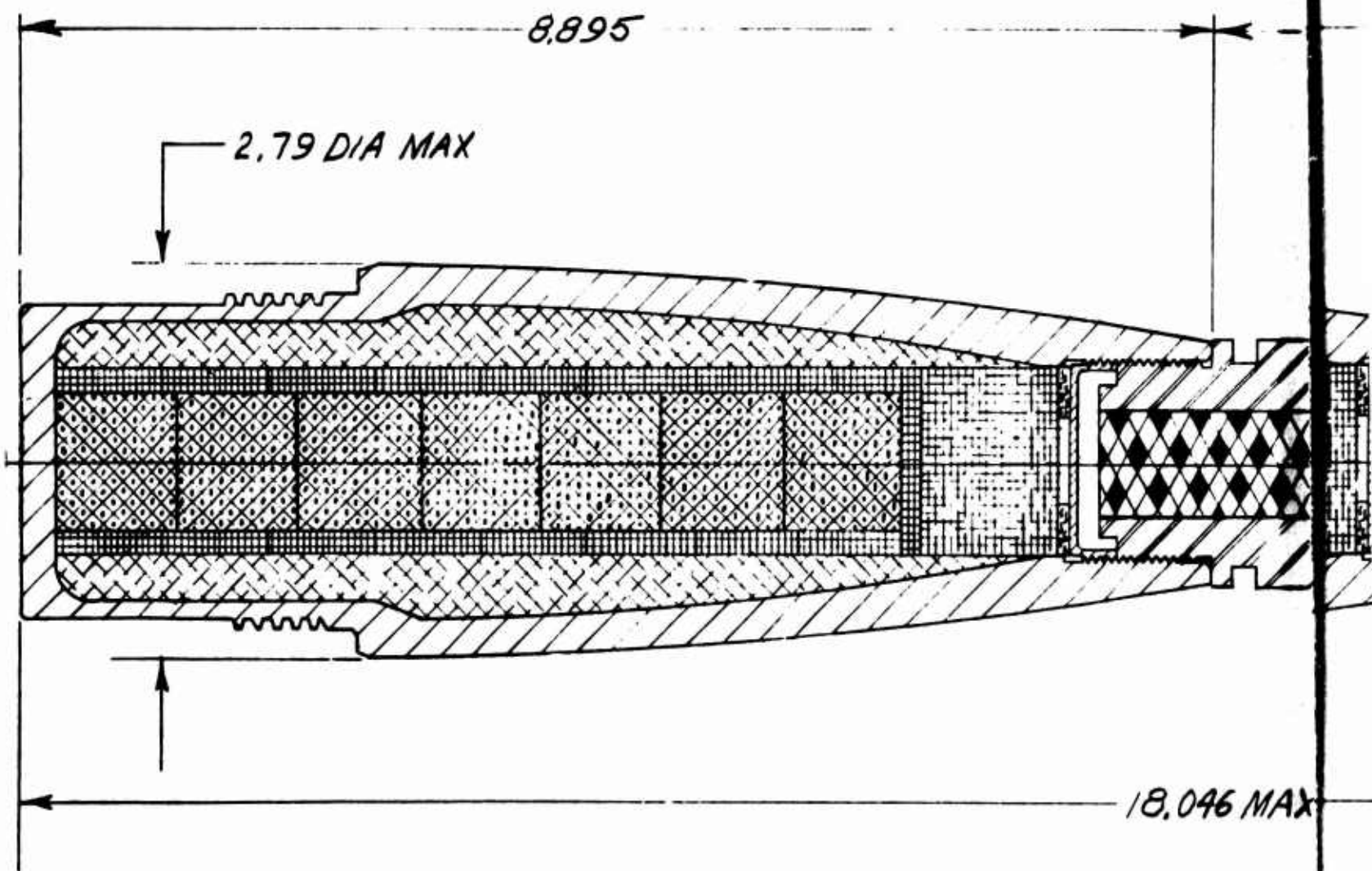
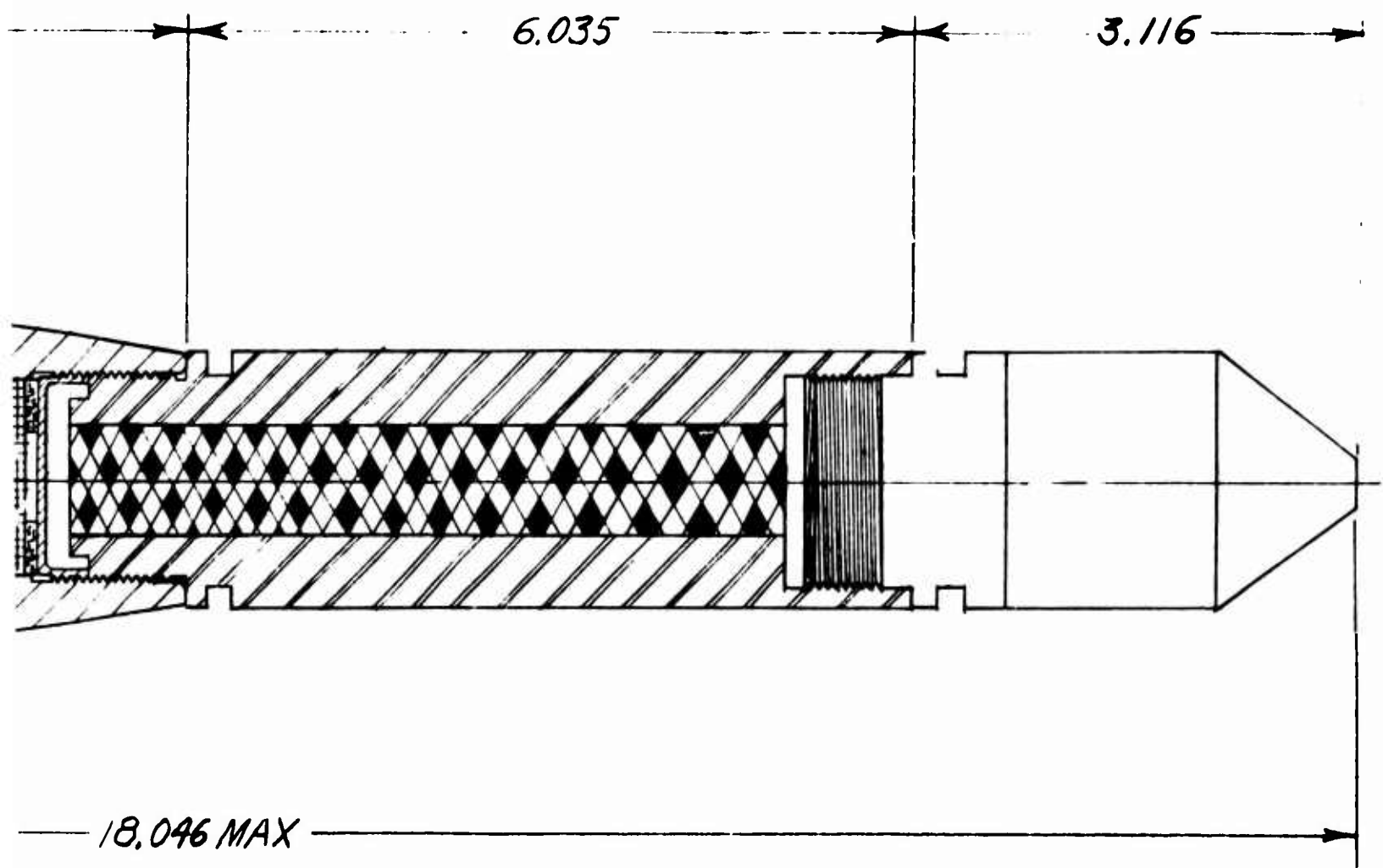

Fig 3 Slurry blend loading for 10-pound hardware (dwg P-135046)

46)

A



BLANK PAGE

APPENDIX A

Drawing List

6-lb XM152 Red and XM153 Yellow Color Markers*	
Loading assembly	P-134817
Body (U. S. Navy Ord Dwg)	660853
Pellet, smoke	P-134822
Washer, felt	P-134818
Pellet, tetryl	P-134819
Wafer, salt	P-134820
Pellet, salt, hollow	P-134821
10-lb Red and Yellow Colored Markers	
Loading assembly	P-135046
Body	X-10524295
Pellet, smoke	P-134822
Ring, felt	P-134818
Pellet, tetryl	P-134819
Wafer, salt	P-134820
Pellet, salt, hollow	P-134821
10-lb Red, Yellow, Green and Blue Colored Markers, Slurry Mixed	
Loading assembly	P-135276
Body	X-10524295
Pellet, smoke	P-135277
Washer, felt	P-134818
Pellet, tetryl	P-134819
Wafer, salt	P-134820
10-lb White Colored Marker	
Loading assembly	P-135290
Body	X-10524295
Smoke canister loading assembly	P-135291

*Federal stock numbers: XM152; 1340-965-0842; H-845
XM153; 1340-965-0843; H-846

10-lb White Colored Marker (cont)

Disc	P-135292
Tube	P-135293
Washer, felt	P-134818
Pellet, tetryl	P-134819

Packing drawings for either 6-lb or 10-lb warheads are:

Fiber container	F-8885029
Packing Box	C-8885030

APPENDIX B

PA-PD-2591, Revision 1 (21 August 1964) plus Amendment 1 and Amendment 2

PA-PD-2591, Rev 1, 21 Aug 1964
SUPERSEDING PA-PD-2591, 10 July 1964

PURCHASE DESCRIPTION

WARHEAD, 2.75 INCH ROCKET, HE
RED MARKER, XM152, AND
YELLOW MARKER XM153 WITH FUZE
LOADING, ASSEMBLING, AND PACKING

1. SCOPE

1.1 This specification covers the quality assurance provisions, and special requirements not covered by the drawings, for two types of spotting charges designated as Warhead, 2.75 Inch Rocket, HE, Red Marker, XM152 and Yellow Marker, XM153, with fuze (see 6.5 and 6.8).

2. APPLICABLE DOCUMENTS

2.1 The following documents of the issue in effect on date of invitation for bids, or request for proposals, form a part of this specification to the extent specified herein.

SPECIFICATIONS

MILITARY

- MIL-S-271 – Stearic Acid, Technical.
- MIL-A-2550 – Ammunition and Special Weapons, General Specification for.
- MIL-I-45208 – Inspection Requirements, General Specification for.
- MIL-I-45607 – Inspection Equipment, Supply and Maintenance of.
- MIL-D-50029 – Dye, Vat Yellow 4.
- MIL-D-50074 – Dye, Benzanthrone.

STANDARDS

MILITARY

- MIL-STD-105 – Sampling Procedures and Tables for Inspection by Attributes.

MIL-STD-109 – Quality Assurance Terms and Definitions.

MIL-STD-1235 – Single and Multilevel Continuous Sampling Procedures and Tables for Inspection by Attributes.

FSC: 1340

DRAWINGS

ORDNANCE CORPS

P-134711 – 2.75 Inch (see table) Marker Warhead (see table) Assembly.

8885029 – Container, Ammo., Fiber, M519 for Warhead, 2.75 Inch Rocket, HE, XM150, with Fuze, Rocket, XM423.

8885030 – Box, Packing, Ammo., for Warhead, 2.75 Inch Rocket, HE, XM150, with Fuze, Rocket, XM423.

PUBLICATIONS

ORDNANCE CORPS

PA-PD-382 – Dye, Red.

IEL-9200426 – Index of Inspection Equipment Lists.

(Copies of specifications, standards, drawings and publications required by suppliers in connection with specific procurement functions should be obtained from the procuring activity or as directed by the contracting officer.)

3. REQUIREMENTS

3.1 Material.—Materials and parts shall be in accordance with applicable drawings and specifications.

3.2 Loaded assemblies.—The loaded assemblies shall comply with all the requirements of Drawing (dwg) P-134817 and with all requirements specified in applicable specifications.

3.3 HVT golden yellow dye.—The HVT golden yellow dye shall be in accordance with Specification MIL-D-50029, except for the following:

- a. Purity shall be 88 percent, minimum.
- b. The anti-dusting agent content shall be 0.5 percent, maximum.

c. The particle size shall be the size produced by the manufacturing process.

3.4 Benzanthrone dye.—The benzanthrone dye shall be in accordance with Specification MIL-D-50074, except for the following:

- a. Purity shall be 98 percent, minimum.
- b. The anti-dusting agent content shall be 0.5 percent, maximum.

3.5 Composition of yellow marker dye.—The composition of the yellow marker dye shall be as listed below:

HVT	73 to 77 percent
Benzanthrone	18 to 22 percent
Stearic acid (MIL-S-271)	4.0 to 6.0 percent

3.6 Composition of red marker dye.—The composition of the red marker dye shall be as listed below:

Red dye (PA-PD-382, Grade 2)	94.5 to 95.5 percent
Stearic acid (MIL-S-271)	4.5 to 5.5 percent

3.7 Smoke color test.—The warhead, when detonated, shall exhibit the applicable colored smoke cloud with no burning apparent when initiated (see 6.6).

3.8 Fuze assembly torque.—The fuze shall be assembled to withstand subsequent application of the minimum assembly torque, specified on the applicable drawing, without moving.

3.9 Workmanship.—All components shall be fabricated and assembled in accordance with best practices. They shall be free of all foreign matter. Metal parts shall be free of rust and other foreign matter. The cleaning method used shall not be injurious to any part nor shall all the parts be contaminated by the cleaning agent. All required markings shall be neat and sharply defined.

4. QUALITY ASSURANCE PROVISIONS

4.1 General quality assurance provisions.—Suppliers responsibility will be as specified in the contract or purchase order. Reference shall be made to Standard MIL-STD-109 in order to define terms used herein. The provisions of Specification MIL-A-2550 shall apply.

4.1.1 Contractor quality assurance system.—The contractor shall provide and maintain an effective quality assurance system in compliance with the requirements of Specification MIL-I-45208. The contractor's quality assurance system shall contain a procedure for the reporting of critical defectives found during the course of his inspection and during inspection by the Government. Any critical defect encountered, unless annotated by an asterisk (*) to the right of the characteristic code number (see 6.2), will be reported within 48 hours. A monthly summary report covering those critical defects annotated by an asterisk will be furnished. The agencies to whom the reports will be furnished are identified in paragraph 6.6. The reports shall contain, as a minimum, the following information:

- a. Contractor and contract number.
- b. Number and revision date of specification.
- c. Characteristic code number.
- d. Lot or serial number.
- e. Number of defectives found.
- f. Assignable cause or analysis of occurrence.

g. Corrective action taken or recommended. When the corrective action is beyond the control of the contractor or the scope of the contract, the report shall contain the contractor's recommendation to the Government.

4.1.2 Submission of product.—At the time the completed lot of product is submitted to the Government for acceptance the contractor shall supply the following information accompanied by a certificate which attests that the information provided is correct and applicable to the product being submitted:

- a. A statement that the lot complies with all quality assurance provisions of the approved current written description of the system.
- b. Number of units of product inspected.
- c. Results obtained for all inspection performed.
- d. Drawing, specification number and date, together with an identification and date of changes.
- e. Certificates of analyses on all material purchased by the contractor when such material is controlled by specifications referenced in any of the contractual documents.
- f. Number of items in the lot.
- g. Date submitted.

The certificate shall be signed by a responsible agent of the certifying organization. The initial certificate submitted shall be substantiated by evidence of the agent's authority to bind his principal. Substantiation of the agent's authority will not be required with subsequent certificates unless, during the course of the contract, this authority is vested in another agent of the certifying organization.

4.1.3 Government verification.—Using the contractor's written quality assurance procedure, this detail specification, the applicable drawings and other contractual documents as a guide, the Government inspector shall verify at unscheduled intervals all quality assurance operations performed by the contractor. Verification will be in accordance with Specification MIL-I-45208 and will be performed to the extent necessary to assure compliance with the contractual requirements. Severity of Government inspection of individual characteristics will be directly related to the seriousness of the classification assigned. In no instance will a characteristic classified "critical" be accepted solely on the basis of the contractor's records.

4.2 Inspection provisions

4.2.1 Lot formation.—A lot shall consist of loaded warheads produced by one manufacturer in one unchanged process, in accordance with the same drawing, same specification, and same specification revision. Drawing, specification, and process changes not affecting safety, performance, or fit, as determined by the Government, shall not necessitate changing the lot interfix number. A lot shall not contain a constituent dye from more than one lot (batch) of that dye.

4.2.2 Examination.—Sampling plans and procedures for the following classifications of defects shall be in accordance with Standard MIL-STD-105 except that inspection for critical defects, when listed, shall be 100 percent. Continuous sampling plans in accordance with Standard MIL-STD-1235 may be used if approved by the procuring activity. Also, at the option of the procuring activity, AQL's and sampling plans may be applied to the individual characteristics listed using an AQL of 0.40 percent for each major defect and an AQL of 0.65 percent for each minor defect. Equipment necessary for the performance of the inspections listed shall be in accordance with 4.2.4.

4.2.2.1 Warhead, empty, prior to coating interior (see dwg P-134817 covering a detail of dwg P-134711).

Categories	Defects	Method of Inspection	Code No.
Critical	None defined		
Major 101	AQL 0.40 percent Foreign matter or rust on interior surface	Visual	01001
Minor	None defined		

4.2.2.2 Warhead, empty, after coating (see dwg P-134817 covering a detail of dwg P-134711).

Categories	Defects	Method of Inspection	Code No.
Critical 1	Foreign matter in charge cavity	Visual	02001
Major 101	AQL 0.40 percent Bare spot in interior coating	Visual	02002
Minor	None defined		

4.2.2.3 Pellet, smoke (see dwg P-134822 covering a detail of dwg P-134817).

Categories	Defects	Method of Inspection	Code No.
Critical	None defined		
Major 101	AQL 0.40 percent Weight	Balance	03001
Minor	AQL 1.50 percent		
201	Diameter, minimum (min)	Gage	03002
202	Length, min	Gage	03003
203	Evidence of poor workmanship (see 3.9)	Visual	03004

4.2.2.4 Loading assembly, prior to assembly of dye (see dwg P-134817 covering a detail of dwg P-134711).

Categories	Defects	Method of Inspection	Code No.
Critical	None defined		
Major	AQL 0.40 percent		
101	Excessive explosive missing at nose	Visual	04001
102	Paint missing from cavity	Visual	04002
Minor	None defined		

4.2.2.5 Loading assembly, prior to assembly of booster pellets (see dwg P-134817 covering a detail of dwg P-134711).

Categories	Defects	Method of Inspection	Code No.
Critical			
1	Dye color improper (see 6.4)	Visual	05001
Major	None defined		
Minor	None defined		

4.2.2.6 Loading assembly, prior to closing (see dwg P-134817 covering a detail of dwg P-134711).

Categories	Defects	Method of Inspection	Code No.
Critical	None defined		
Major	AQL 0.65 percent		
101	Pad missing	Visual	06001
102	Tetryl pellet missing	Visual- Manual	06002
103	Wafer missing	Visual- Manual	06003
Minor	None defined		

4.2.2.7 Loading assembly (see dwg P-134817 covering a detail of dwg P-134711).

Categories	Defects	Method of Inspection	Code No.
Critical			
1	Color coding improper	Visual	07001
Major			
101	Depth to liner surface	Gage	07002
Minor	AQL 1.50 percent		
201	Marking missing, misleading or unidentifiable	Visual	07003
202	Paint on fuze thread	Visual	07004
203	Compound missing from thread	Visual	07005

4.2.2.8 Warhead assembly (see dwg P-134711).

Categories	Defects	Method of Inspection	Code No.
Critical	None defined		
Major	AQL 0.40 percent		
101	Fuze assembly torque under minimum (see 4.3.6)	Test	08001
Minor	AQL 0.65 percent		
201	Exterior coating damaged	Visual	08002

4.2.2.9 Container, fiber, sealed (see dwg 8885029).

Categories	Defects	Method of Inspection	Code No.
Critical	None defined		
Major	AQL 0.65 percent		
101	Tape incomplete or badly wrinkled	Visual	09001
102	Cuts, scuffs, gouges or checks which penetrate outer layer	Visual	09002
103	Metal end loose or distorted	Visual-Manual	09003

Minor	AQL 1.50 percent		
201	Length of tear tab, min	Gage	09004
202	Gap between body and cover in excess of 1/4 inch	Gage	09005
203	Marking missing, misleading or unidentifiable (see 5.1.2)	Visual	09006
204	Contents loose	Manual	09007

4.2.2.10 Box, packing (see dwg 8885030).

Categories	Defects	Method of Inspection	Code No.
Critical	None defined		
Major	AQL 0.65 percent		
101	Content of box exposed	Visual	10001
102	Hardware missing, broken or loose	Visual	10002
103	Strapping missing, broken or loose	Visual	10003
104	Board broken	Visual	10004
Minor	AQL 1.50 percent		
201	Marking missing, misleading or unidentifiable (see 5.2.2)	Visual	10005
202	Hardware improperly engaged	Visual	10006
203	Car seal missing, unsealed or improperly positioned	Visual	10007

4.2.3 Testing

4.2.3.1 Salt pellet and wafer dimensions (see dwgs P-134820 and P-134821).—At the start of each run of the pellet and the wafer each unit produced shall be dimensionally examined and adjustments made until five (5) consecutively produced units meet the applicable dimensional requirements. Subsequent units shall be produced with no change in process. Periodic examinations shall be performed to assure continued dimensional integrity.

4.2.3.2 Density of tetryl pellet (see dwg P-134819). Major defect. Code No. 11001.—A sample of ten (10) pellets shall be selected from each inspection lot for this determination which shall be performed in accordance with 4.3.4. Failure of one or more units of the sample in meeting the requirements shall reject the lot.

4.2.3.3 Composition of yellow marker dye (see 3.5). Major defect. Code No. 12001.—Prior to mixing the marker dye, a one (1) ounce sample of the golden yellow indanthrene dye shall be selected for assistance in the determinations of 4.3.1. One (1) pellet shall be selected from each batch for the determinations. Failure of the sample in meeting any requirements shall reject the batch, subject to retest. For retest, two (2) additional pellets shall be analyzed. Failure of either in meeting each requirement shall reject the batch.

4.2.3.4 Composition of red dye (see 3.6). Major defect. Code No. 13001.—One (1) pellet shall be selected from each batch for this determination which shall be performed as specified in 4.3.2. Failure of the sample in meeting the requirement shall reject the batch, subject to retest. For retest, two (2) additional pellets shall be analyzed. Failure of either in meeting the requirement shall reject the batch.

4.2.3.5 Composition of explosive (see dwg P-134817). Major defect. Code No. 14001.—A minimum sample of four (4) grams shall be selected at the pouring spout from each batch of baratol for this determination which shall be performed as specified in 4.3.3. Failure of the sample in meeting either requirement shall reject the batch.

4.2.3.6 Smoke color test (see 3.7). Major defect. Code No. 15001.—A sample of five (5) loading assemblies, dwg P-134817, shall be selected from each lot for this determination which shall be performed as specified in 4.3.5. Failure of one or more units in meeting either requirement shall reject the lot.

4.2.4 Inspection equipment.—Index of Inspection Equipment Number IEL-9200426 identifies the inspection equipment required to perform the examinations and tests prescribed in this section. The contractor shall design inspection equipment in accordance with the instructions in paragraph 6.3.

4.2.4.1 Government rights to documentation.--Inspection equipment drawings and lists provided and revised in accordance with the requirements of the IEL may be used by DOD activities for design, procurement, manufacture, testing, evaluation, production and receiving inspection, overhaul, shipping, storage, identification of stock, ordering and storage of replacement of parts, inspection of items at overhaul, general maintenance of equipment, construction, survey and wherever inspection equipment drawings are needed.

4.2.4.2 Supply and maintenance.--Supply and maintenance of the equipment listed on the IEL shall be in accordance with Specification MIL-I-45607.

4.2.4.3 Government use of contractor's inspection and test equipment.--The contractor shall make available to the Government all inspection and test equipment necessary for determining conformance with contract requirements. Personnel for operating the equipment, and verification of its accuracy, shall be supplied by the contractor for the performance of examination or test by the Government.

4.3 Test methods and procedures.

4.3.1 Composition of yellow marker dye.--The analysis of the yellow marker dye shall be performed with the following equipment and detailed procedure:

A. Golden Yellow Indanthrene

1. Apparatus: Spectrophotometer, Beckman Instruments Inc. Model DU or its equivalent. Use 1 cm cells.

2. Determination of Absorptivity: An accurately weighed portion of 0.1000 gm of the golden yellow indanthrene shall be dissolved in approximately 400 ml of reagent grade benzene. (It was found necessary to bring the mixture to a boil to insure complete dissolution of the sample.) Cool, if necessary, and transfer quantitatively to a 500 ml volumetric flask. Dilute to the mark with benzene. Filter approximately 100 ml of this solution through a dry No. 42 Whatman filter paper, discarding the initial portion of the filtrate. Prepare standard solutions of 6.5, 7.0, 7.5, 8.0, 8.5 ml aliquots of the filtrate to 100 ml volumes in volumetric flasks. Determine the

absorptivity of each solution at 463 mu, using benzene as the reference standard, by substitution in the following equation:

$$a = \frac{A}{c}$$

where: a - absorptivity (found to be about 0.540)

A - absorbance

c - concentration, mg/100 ml (the plot of A against c should comply with Beer's Law). Use the average of the five standard solutions as the absorptivity of the dye. (This value should be determined whenever a new batch of yellow dye is used in the preparation of the samples to be tested. The absorbance of new batches of benzanthrone should be checked at 463 mu.)

3. Procedure: Accurately weigh a portion of approximately 0.1000 gm of the sample and transfer to a 400 ml beaker. Add approximately 350 ml of reagent grade benzene and heat gently to boiling. Allow to cool. Transfer, quantitatively, to a 500 ml volumetric flask, dilute to the mark with benzene, and mix thoroughly. Filter approximately 40 ml of the solution through a dry No. 42 Whatman filter paper, discarding the initial portion. Transfer a 10 ml aliquot to a 100 ml volumetric flask, dilute to the mark with benzene and mix thoroughly. Determine the absorbance of this solution at 463 mu, using benzene as the reference standard, and calculate the percent yellow dye as follows:

$$\% \text{ Golden yellow indanthrene} = \frac{5A}{axW}$$

where: A - absorbance

a - absorptivity

W - wt of sample in gm

B. Stearic Acid

1. Apparatus:

a. Leeds and Northrup Co., Model No. 7662 pH indicator or its equivalent.

b. Magnetic stirrer, Fischer Scientific Co.

2. Solutions:

a. Approximately 0.1 normal sodium hydroxide solution (4.0 gm per liter).

b. Buffer solution of pH 10.

3. Procedure: Accurately weigh approximately 3.000 gm of the sample and transfer to a 250 ml beaker. Add 100 ml of 95% ethanol. Adjust the pH meter to its optimum operating condition by using the buffer solution. Place the 250 ml beaker, containing the sample, upon the magnetic stirrer. Activate the stirrer. Lower the electrodes into the mixture, taking care to leave ample room at the bottom for the magnetic bar. Titrate the sample with standardized 0.1 normal sodium hydroxide to a pH of ten (10). (Should the pH tend to drift toward pH 9 add additional caustic until a pH of 10 is maintained.) Calculate the percent stearic acid as follows:

$$\% \text{ Stearic acid} = \frac{(A-B) C \times 28.447}{W}$$

where: A - volume of 0.1 normal sodium hydroxide used for sample
B - volume of 0.1 normal hydroxide used for blank*
C - normality of hydroxide
W - wt of sample

*Blank consists of 2.25 gm yellow dye, 0.60 gm benzanthrone, 100 ml 95% ethanol.

C. Benzanthrone

1. Procedure: The percentage of the benzanthrone shall be calculated by subtracting from 100 the combined percentages of the golden yellow indanthrene and the stearic acid.

4.3.2 Composition of red marker dye.—The analysis of the red marker dye shall be performed with the following equipment and detailed procedure:

4.3.2.1 Stearic acid content.

A. Special apparatus

1. Leeds and Northrup pH Indicator, Model No. 7662, or equivalent, with electrode holder.
2. Magnetic stirrer.

B. Reagents

1. Standardized sodium hydroxide solution of approximately 0.1 normal concentration (4.00 gm ACS reagent grade sodium hydroxide per liter of water).

2. Standard buffer solution of pH 10.

C. Procedure

1. Accurately weigh a portion of approximately 3.00 gm of the sample and transfer to a 25 ml beaker.
2. Adjust the pH indicator to its optimum condition by the use of the buffer solution.
3. Add 100 ml of 95 percent ethanol to the beaker, place beaker and contents atop the magnetic stirrer.
4. Lower the electrodes into the mixture (take care to leave ample space at the bottom of the stirrer bar).
5. Activate the stirrer and add the 0.1 normal sodium hydroxide (from a buret) to the sample mixture to a pH of 10.

D. Calculate the percent stearic acid as follows:

$$\% \text{ Stearic acid} = \frac{AB \ 28.447}{W}$$

where: A - milliliters of sodium hydroxide added
B - normality of sodium hydroxide
W - weight of sample

NOTES:

1. A blank determination should be run on an equivalent amount of the dye in 100 ml of the 95 percent ethanol to be used in the analysis of the sample.
2. If the sample should fail to comply with the requirements the amount of stearic acid added may be determined by checking the purity of the stearic acid used and dividing the obtained "percent stearic acid" results by the percent purity.
6. Red dye content.—The red dye content shall be calculated as the difference between the percent stearic acid and 100.

4.3.3 Composition of explosive.

4.3.3.1 Barium nitrate content.—Transfer an accurately weighed portion of approximately 2 gm of the sample to a 400 ml beaker. Add 200 ml of benzene and allow the mixture to digest on a boiling water bath for one hour. Then transfer the insoluble barium nitrate quantitatively to a tared Gooch crucible which has been previously washed with benzene and dried at 100

plus or minus 2 degrees Centigrade (C) for one hour. Wash the content of the crucible with four 25 ml portions of benzene, aspirate until most of the benzene is removed, dry for one hour at 100 plus or minus 2 degrees C, cool in desiccator and weigh. Calculate the increase in weight of the crucible as percent barium nitrate.

4.3.3.2 TNT content.—Calculate the TNT content by subtracting the percentage of barium nitrate from 100.

4.3.4 Density of tetryl pellet.—The pellet shall have any pelletizing dust and excess material removed from its surface. It shall then be carefully placed in a solution of potassium iodide with a specific gravity of 1.76. The solution shall be thoroughly stirred and its specific gravity checked with a hydrometer before each usage. If the pellet floats, it may be tumbled with a probe to remove adhering air bubbles. If it does not then sink into the solution, it shall be classed defective.

NOTE: The pellet shall not be in contact with the solution for more than ten (10) seconds.

4.3.5 Smoke color test.—In preparation for each test, a steel plug approximately $\frac{1}{2}$ inch thick with 1 $\frac{7}{16}$ -16 UN-2B threads and a slot across one face for tightening. A tetryl booster pellet for the XM423 Fuze, dwg 8883685, shall be placed on the fuze cavity liner of the warhead and the threaded plug assembled until it touches the pellet. A J-2 electric blasting cap shall be connected to a grounded power source and the blasting cap shall then be placed in the hole in the plug in contact with the pellet and be securely taped in. The warhead shall be attached to the top of a 1.5 foot pole at an angle of approximately 45 degrees from the horizontal with the nose down. The warhead shall then be detonated and observation made for color and burning in the cloud.

4.3.6 Fuze assembly torque.—A line shall be scribed or marked across the fuze-warhead junction to provide a means for detection of movement between the components. The minimum torque shall then be applied in the tightening direction. Observation shall then be made for movement of the fuze. Any discernible movement shall be regarded as a test failure. (When thread sealing compound or adhesive is used on the joint, the minimum torque shall be applied while the compound or adhesive is wet.)

5. PREPARATION FOR DELIVERY

5.1 Packaging

5.1.1 Level A.—The warheads shall be packaged in accordance with dwg 8885029.

5.1.2 Marking.—The fiber containers shall be marked in accordance with dwg 8885029 except that the descriptive nomenclature shall be "1-Warhead, 2.75 Inch Rocket, HE, Red Marker, XM152" or "Yellow Marker, XM153", as applicable.

5.2 Packing

5.2.1 Level A.—The packaged units shall be packed in accordance with dwg 8885030.

5.2.2 Marking.—The boxes shall be marked in accordance with dwg 8885030 except that the descriptive nomenclature shall be as in 5.1.2 and the quantity shall be 24.

5.3 Data cards.—Data card information shall be prepared for each lot as specified in Specification MIL-A-2550.

6. NOTES

6.1 Ordering data.—Procurement documents shall specify the following:

- a. Title, number and date of this specification.
- b. Color and designation of marker required.

6.2 Inspection code numbers.—The five digit code numbers assigned to the inspections herein are to facilitate future data collection and analysis by the Government.

6.3 Inspection equipment.—The contractor shall design inspection equipment as required by the referenced Inspection Equipment Lists (IEL) in accordance with the instructions of 6.3.1 through 6.3.7.

6.3.1 Inspection equipment lists.—Inspection Equipment Lists indicate the availability of inspection equipment designs by showing in the “number” column of the list of inspection equipment (OO Form 1242-3) the numbers of drawings of existing equipment designs or codes as indicated in 6.3.2. Design action required of the contractor with respect to the different types of drawings that may be listed is described in 6.3.3 and 6.3.4. Action required by the contractor with respect to commercial inspection equipment is described in 6.3.5. The contractor will be required to prepare detailed drawings in accordance with 6.3.6 for all the equipment coded as “contractor design” in the number column. These contractor designs must be approved by the Government prior to fabrication or procuring of the equipment. Designs shall be submitted for approval as specified in 6.3.7.

6.3.2 Inspection equipment list codes.—The inspection equipment as defined in 6.3.3, 6.3.4, 6.3.5, and 6.3.6 will be designated in the Inspection Equipment List by the following codes:

- CDAF – Contractor’s design responsibility on Army format in accordance with MIL-D-45608
- CDCF – Contractor’s design responsibility on contractor format
- AD – Army design
- ADMU – Army design, mandatory for use
- CE – Commercial equipment
- SCD – Specification control drawing

6.3.3 Army designs.—Army designs are reflected on detailed drawings which completely depict all the information necessary for the fabrication of the item of inspection equipment. The contractor need provide no design when an Army design is listed for an item of inspection equipment. Army designs fall into two basic classifications; mandatory and non-mandatory. When an Inspection Equipment List references mandatory Army designs, the contractor shall comply with, and use these designs accordingly. The contractor may, however, in connection with non-mandatory designs and with the approval of the Government, design alternate inspection equipment or use comparable commercial equipment to facilitate his operations. Such contractor prepared designs or commercial equipment selections must be approved by the Government prior to fabrication or procuring of the equipment. Designs shall be submitted for approval as specified in 6.3.7.

6.3.4 Specification control drawings.—Specification control drawings depict the minimum equipment requirements in outline, descriptive, diagrammatic, or pictorial form only and specify the required performance or other characteristics. Contractors must prepare detailed drawings (see 6.3.6) of their designs in support of specification control drawings. These contractor prepared designs must be approved by the Government prior to the fabrication or procuring of the equipment. Commercial equipment meeting the requirements of specification control drawings may be approved if described in sufficient detail to permit identification and evaluation by the Government. Designs shall be submitted for approval as specified in 6.3.7.

6.3.5 Commercial equipment.—Commercial equipment is inspection equipment that has universal application for a specific function. It is comprised of items commonly used by industry and government. Contractors are not required to furnish drawings of commercial inspection equipment but a list of such equipment must be approved by the Government. Lists shall be submitted for approval to the inspection element of the agency administering the contract.

6.3.6 Contractor designs.—Contractor designs are designs of inspection equipment for which the Government has assigned design responsibility to the contractor. Contractor designs shall be supported by detailed drawings which depict all information necessary to completely fabricate, calibrate and operate an item of inspection equipment. This requires that the necessary views, dimensions, materials, finish, notes, operating and calibration instructions be properly depicted in accordance with approved practices to the extent that further calculation or clarification will not be required. Contractor designs identified as CDCF may be developed on the format the contractor normally employs in his equipment design procedure provided such format reflects the detail and information specified above. Contractor designs identified as CDAF shall comply with the format and requirements of MIL-D-45608, and, in addition, contain the detail and information specified above.

6.3.7 Submission of contractor designs.—Designs shall be submitted for approval to the Commanding Officer, Picatinny Arsenal, ATTN: SMUPA-ND. Design review will normally be accomplished within one month after receipt by Picatinny Arsenal. Partial submission of inspection equipment

designs is permissible and encouraged. However, the Arsenal completion date for design review will be based on the date of the final submission of designs.

6.4 Pellet color check.—The visual appearance of the red and the yellow pellets is similar. The true color may be determined by scratching on edge of a pellet across paper.

6.5 Intended use.—It is intended that the items of this specification will be used in Rocket, 2.75 Inch.

6.6 Smoke color test.—This test will be performed at Picatinny Arsenal, Dover, New Jersey.

6.7 Submission of critical defect reports.—For U. S. Army Munitions Command procurements, one copy of each critical defect report will be furnished the cognizant Government inspection agency; the Army Ammunition Procurement and Supply Agency, ATTN: SMUAP-RO; Picatinny Arsenal, ATTN: SMUPA-ND.

6.7.1 Reporting to other services.—For other than U. S. Army Munitions Command procurements, critical defect reporting shall be as prescribed by the Contracting Officer.

6.8 Fuzes.—The procuring activity shall furnish a sufficient quantity of XM423 Fuzes for each procurement.

Custodian:
Army-MU

Preparing activity:
Army-MU

PA-PD-2591, Revision 1
AMENDMENT 1
29 March 1965

PURCHASE DESCRIPTION

WARHEAD, 2.75 INCH ROCKET, HE,
RED MARKER, XM152, AND
YELLOW MARKER XM153 WITH FUZE
LOADING, ASSEMBLING, AND PACKING

This Amendment forms a part of Purchase Description PA-PD-2591, Revision I, dated 21 August 1964.

Page 3, paragraph 3.7, line 2: Delete "with no burning apparent when initiated" and substitute "and there shall be no burning to the extent that the cloud size is appreciably reduced."

Page 3, add paragraph 3.10:

"3.10 Ballistic firing.—The warhead (using an XM423E1 fuze from an acceptable lot and the Mark 40 rocket motor from an acceptable lot) shall function with a high order detonation and a smoke cloud of the proper color upon target impact."

Page 8, paragraph 4.2.2.7, delete lines 7 and 8 and substitute:

"Major: AQL 0.40 percent
101. Depth to liner bottom surface....Gage 07002"

Page 10, add paragraph 4.2.3.7:

"4.2.3.7 Ballistic test (see 3.10).—Beginning with the first production lot and continuing until three consecutive lots have passed the acceptance criteria prescribed, twenty-five warheads shall be selected and tested from each lot. Each warhead shall be assembled to an XM423E1 fuze from an acceptable lot and the Mark 40 rocket motor from an acceptable lot. If two or more warheads fail to detonate high order with an acceptable smoke cloud of the proper color on target impact, the lot shall be rejected.

Page 15, delete paragraph 4.3.5 and substitute:

“4.3.5 Smoke color test.—Steel plugs approximately $\frac{1}{2}$ inch thick with 1 $\frac{7}{16}$ -16 UN-2B threads, a $\frac{5}{16}$ inch hole through the center and a slot across one face for assembly shall be prepared. A tetryl booster pellet for the XM423E1 fuze, dwg 8883685, shall be placed on the fuze cavity liner of the warhead and the threaded plug assembled until it touches the pellet. A J-2 electric blasting cap shall be connected to a grounded power source and the blasting cap shall then be placed in the hole in the plug in contact with the top of a 1.5 foot pole at an angle of approximately 45 degrees from the horizontal with the nose down. The warhead shall then be detonated and observation made for proper color. There shall be no burning to the extent that the cloud size is appreciably reduced. Motion pictures will be taken in color of the warhead functioning. The temperature, humidity and wind velocity at the time of functioning of each warhead will be recorded.”

Page 15, add paragraph 4.3.7:

“4.3.7 Ballistic test.—The complete warhead with fuze and rocket motor shall be fired at a target consisting of $\frac{3}{4}$ " thick plywood set at 0 degrees obliquity (alternate-earth work composed of any density, under any weather conditions). The distance between the launcher and target shall be a minimum of 350 feet.”

PA-PD-2591, Revision 1
AMENDMENT 2
18 June 1965

PURCHASE DESCRIPTION

WARHEAD, 2.75 INCH ROCKET, HE,
RED MARKER, XM152, AND
YELLOW MARKER, XM153, WITH FUZE
LOADING, ASSEMBLING AND PACKING

This Amendment forms a part of Purchase Description PA-PD-2591, Revision 1, dated 21 August 1964.

Page 3, paragraph 3.7, line 2, delete "with no burning apparent when initiated" and substitute "and there shall be no burning to the extent that the cloud size is appreciably reduced."

*Page 3, add paragraph 3.10: "3.10 Ballistic firing.—The warhead (using an M423 fuze from an acceptable lot and the Mark 40 rocket motor from an acceptable lot) shall function with a high order detonation and a smoke cloud of the proper color upon target impact. A fuze failure shall not be considered a warhead failure."

*Page 3, add paragraph 3.11: "3.11 Weight of bursting composition.—The weight of the bursting composition shall be greater than 1.0 pound."

*Page 8, paragraph 4.2.2.7, defect 1, delete and substitute:

"1. Marking related to color inconsistent..... Visual 07001"

Page 8, paragraph 4.2.2.7, add after Major: "AQL 040 percent".

*Page 8, paragraph 4.2.2.7, defect 101, add after liner, "bottom", and after surface, "maximum".

*Page 10, paragraph 4.2.3.3 line 4, delete "One (1) pellet" and substitute "A 10 gram sample (approximately)".

*Page 10, paragraph 4.2.3.3, line 6, delete "subject to retest" to end of paragraph.

*Page 10, paragraph 4.2.3.4, line 2, delete "One (1) pellet" and substitute "A 10 gram sample (approximately)".

*Page 10, paragraph 4.2.3.4, line 5, delete "subject to retest" to end of paragraph.

*Page 10, add paragraph 4.2.3.7.

"4.2.3.7 Weight of bursting composition. Major defect – Code No. 18001.—A sample of two warhead bodies shall be selected each half shift or fraction thereof that the line operates. Determination shall be as specified in paragraph 4.3.8. Failure of either sample weight shall be cause for rejection of the half shift's production."

*Page 10, add paragraph 4.2.3.8:

"4.2.3.8 Ballistic test (see 3.10).—Beginning with the first production lot and continuing until three consecutive lots have passed the acceptance criteria prescribed, twenty-five warheads shall be selected and tested from each lot. Each warhead shall be assembled to an M423 fuze from an acceptance lot and the Mark 40 rocket motor from an acceptable lot. If two or more warheads fail to detonate high order with an acceptable smoke cloud of the proper color on target impact, the lot shall be rejected. A fuze failure shall not be considered a warhead failure."

*Page 11, paragraph 4.3.1A, delete and substitute:

"A. Golden Yellow Indanthrene

1. Apparatus: Spectrophotometer, Beckman Instruments Inc. Model DU or its equivalent. Use 1 cm cells.

2. Determination of Absorptivity: An accurately weighed portion of 0.020 gm of the golden yellow indanthrene shall be dissolved in approximately 800 ml of reagent grade benzene. (It was found necessary to bring the mixture to a boil to insure complete dissolution of the sample.) Cool, if

necessary, and transfer, quantitatively to a 1000 ml volumetric flask. Dilute to the mark with benzene. Filter approximately 100 ml of this solution through a dry No. 42 Whatman filter paper, discarding the initial portion of the filtrate. Prepare standard solutions of 10, 20, 39 and 40 ml aliquots of the filtrate to 400 ml volumes in volumetric flasks.

Determine the absorptivity of each solution at 463 mu, using benzene as the reference standard by substitution in the following equation:

$$a = \frac{A}{c}$$

where: a = absorptivity (found to be about 0.640)

A = absorbance

c = concentration, mg/100 (plot of A against c should comply with Beer's law). Use the average of the five standard solutions as the absorptivity of the dye. (This value should be determined whenever a new batch of yellow dye is used in the preparation of the samples to be tested. The absorbance of new batches of benzanthrone should be checked at 463 mu).

3. Procedure: Accurately weigh a portion of approximately 0.030 gm of the sample and transfer to a 800 ml beaker. Add approximately 700 ml of reagent grade benzene and heat gently to boiling. Allow to cool. Transfer, quantitatively, to a 1000 ml volumetric flask, dilute to the mark with benzene, and mix thoroughly. Filter approximately 40 ml of the solution through a dry No. 42 Whatman filter paper, discarding the initial portion. Transfer a 25 ml aliquot to a 100 ml volumetric flask, dilute to the mark with benzene and mix thoroughly. Determine the absorbance of this solution at 463 mu, using benzene as the reference standard, and calculate the percent yellow dye as follows:

$$\% \text{ Golden yellow indanthrene} = \frac{4A}{axW}$$

where:

A = absorbance

a = absorptivity

W = wt of sample in gms."

*Page 15, paragraph 4.3.4, delete and substitute:

“4.3.4 Density of tetryl pellet.—The density of the pellet may be determined by any approved standard method.”

*Page 15, paragraph 4.3.5, delete and substitute:

“4.3.5 Smoke color test.—Steel plugs approx ½ inch thick with 1 7/16 UN-2B threads, a 5/16 inch hole through the center and a slot across one face for assembly shall be prepared. A tetryl booster pellet for the M423 Fuze, dwg 8883685, shall be placed on the fuze cavity liner of the warhead and the threaded plug assembled until it touches the pellet. A J-2 electric blasting cap shall then be placed in the hole in the plug in contact with the pellet and be securely taped in. The warhead shall be attached to the top of a 1.5 foot pole at an angle of approx 45 degrees from the horizontal with the nose down. The warhead shall then be detonated and observation made for color and there shall be no burning to the extent that the cloud size is appreciably reduced. Motion pictures will be taken in color of the warhead functioning. The temperature, humidity and wind velocity at the time of functioning of each warhead will be recorded.”

*Page 15, paragraph 4.3.7, delete and substitute:

“4.3.7 Ballistic test.—The complete warhead with fuze and rocket motor shall be fired at a target of ¾ inch thick plywood set at 0 degrees obliquity. The distance between the launcher and target shall be a minimum of 350 feet. High speed (Fastex) camera coverage using black and white film shall be employed to determine fuze functioning.”

Page 15, add paragraph 4.3.8:

“4.3.8 Weight of bursting composition (see para. 3.11).—A sample warhead body shall be selected prior to loading and shall be weighed to the nearest .01 pound. The sample shall be loaded and faced as in regular production and then reweighed. The difference between the two weights shall be the weight of bursting composition.”

*Indicates changes or additions to previous amendment.

APPENDIX C

Engineer Design Test of 2.75 Inch FFAR Color Marker Warheads, XM152 (Red) and XM153 (Yellow)

DEVELOPMENT AND PROOF SERVICES ABERDEEN PROVING GROUND, MARYLAND FIRING RECORD R-3574

(Dates of Test: 8 August to 16 September 1964)

ITEMS UNDER TEST

Warheads, color marker, XM152 (red) and XM153 (yellow) for 2.75-inch, FFAR rocket Mk 40, XM152 warhead lot PA-E-50114, XM153 warhead lot PA-E-50113.

SUPPORTING FACILITIES AND MATERIALS

Ammunition:

Fuze, PD, XM423 for 2.75-inch, FFAR rocket, lot LS-3-1.
Motor, rocket, 2.75-inch, Mk 40, LSFFAR, lot RMHA312A-S-53.

Weapon:

Rocket launcher, XM3, mounted on modified howitzer carriage and on UH-1B helicopter.
Rocket launcher, LAU-3A mounted on UH-1B helicopter.
Tube, special, 21-foot, for firing the 2.75-inch rocket, mounted on a modified howitzer carriage^a.

Facilities:

Bombproofs, Class A.
Observation towers at Bush Point and H Tower.
Drop test facility equipped with a quick-release hook.

^aThis special tube was used on the plate firings only.

DETAILS OF TEST

A series of tests, as outlined in the test plan (Inclosure 1), were conducted to complete a safety evaluation of the XM152 and XM153 color marker warheads. Further description of each test performed is presented below:

a. The 40-foot and 5-foot drop tests, jolt and jumble tests, and temperature-humidity tests were conducted with warheads assembled with dummy fuzes. All other tests were conducted using XM423 fuzes.

b. The transportation vibration test (in boxes) was conducted according to TECP 700-700, Interim Pamphlet 70-73, which consisted of simulated 2000 miles of 2-wheel trailer and simulated 3 hours of air transportation. The loaded boxes were vibrated in the horizontal position. Six warheads of each type were vibrated, while loaded in the boxes used to ship the warheads (four rounds per box).

c. The temperature-humidity tests were conducted according to the 14-day JAN cycle, with +155°F being the maximum temperature.

d. The vibration at extreme temperatures was conducted on unpackaged warheads in three orientations (nose up, nose down, and horizontal).

e. The firing tests from a ground launcher of the above tested warheads were conducted for water impact using 2.75-inch rocket motors and XM423 fuzes. The warheads damaged during the testing were not rocket fired. The rounds described in paragraph d were fired after temperature conditioning. All other warheads and fuzes, and all rocket motors used were fired at ambient temperature. Range, deflection, and fuze and warhead functioning information were taken during the range firing program.

f. Also, rocket firing tests were conducted from the UH-1B helicopter to ground targets. Two series of tests, one at low altitudes (10 to 75 feet) and one at higher altitudes (100 to 500 feet), were conducted on a total of 122 rounds.

g. In addition, four rounds of each type of warhead were fired at short range against a large heavy armor plate to determine what quality of smoke cloud would be issued by functioning on a hard target or surface.

SUMMARY OF RESULTS

Type of Test Performed	Test Results or Damage Inflicted
Forty-foot drop	Both types of warhead showed light scars, dents, and bulges. Four warheads were not test fired due to the damage inflicted by the drop test.
Five-foot drop	Both types of warheads showed light scars, dents, and bulges. The XM153 warhead 118 was not fired due to the deformation caused by the drop which created a physical interference between the warhead and the motor.
Jolt	There was no apparent damage to the warheads.
Jumble	There was no apparent damage inflicted by this test other than light paint scuffing. The XM153 warhead 108 was not fired due to damage inflicted prior to the jumble test.
Transportation Vibration (in boxes)	All warheads showed damage to the paint caused by chafing against the containers during vibration. The tetryl boosters in the warheads were slightly chipped around the edges.
Temperature-Humidity	The base threads on all warheads were very lightly rusted.
Temperature-Storage	There was no apparent damage.
Vibration at Temperature	There was no apparent damage. All rounds vibrated at +155°F temperature were inspected for exudates. No exudate was found.
Ground Rocket Firing Test	No malfunctions, which would be considered unsafe, occurred during the firing tests.

During the rocket firing tests, the XM153 warhead 9 could not be properly assembled to the rocket motor. The threads on this warhead had been damaged by a setscrew on the vibration fixture. This damage was incidental to the purpose of the vibration test.

The marker warhead performance during the range firing program, in terms of color and quantity of smoke produced, was generally poor. Also, a high percentage of duds (40 duds for 260 rounds fired, or 15%) was experienced.

However, this high dud rate is attributed to the functioning characteristics of the XM423 fuze. Many rounds fired were reported as functions on the basis of detonations heard rather than any visual observation of smoke. The rocket firing tests from the UH-1B helicopter did not result in significantly better marking smoke clouds. Those warheads which impacted in wooded areas produced more smoke than those which impacted in dirt and the smoke clouds were less quickly dissipated by the wind. Seventeen of the 122 warheads fired from the helicopter, or 14%, were duds.

Eight warheads were fired at short range against a large heavy armor plate target. The first four rounds (fired from a 250-foot distance) were duds. The last four rounds (fired at a 354-foot distance) issued dense, brightly colored smoke which dissipated rather quickly (15 to 30 seconds) in a moderate breeze. It is felt that the XM423 fuze was not armed before target impact on the four rounds fired at a distance of 250 feet; therefore, the duds were produced.

Eight warheads were fired at short range against a large heavy armor plate target. The first four rounds (fired from a 250-foot distance) were duds. The last four rounds (fired at a 354-foot distance) issued dense, brightly colored smoke which dissipated rather quickly (15 to 30 seconds) in a moderate breeze. It is felt that the XM423 fuze was not armed before target impact on the four rounds fired at a distance of 250 feet; therefore, the duds were produced.

OBSERVATIONS AND REMARKS

The fuze cavity of several warheads was damaged when received. The damage was probably caused by insertion of the fuze cavity liner into the warhead. These warheads were not used during the tests except for XM153 warhead 108, on which the damage was not noticed until after the jumble test. This warhead was not fired.

It is believed that the water impacts of the warheads fired from a ground launcher, and the dust kicked up by ground impacts of the rounds fired from the UH-1B helicopter, defeated the color marking characteristics of the

warheads to a large extent. This observation is borne out by the results of the rounds fired against the plate.

SUBMITTED:

D. M. POTTER
Test Director

REVIEWED:

MARSHALL T. SMITH
Chief, Rocket and
Missile Branch

APPROVED:

CLAUDE E. BROWN
Chief, Infantry and
Aircraft Weapons Division

APPENDIX D

Engineer Design Test of 2.75 Inch Color Marker Heads, XM152 and T2026

DEVELOPMENT AND PROOF SERVICES ABERDEEN PROVING GROUND, MARYLAND FIRING RECORD R-3612

(Dates of Test: 9 December 1964 to 19 January 1965)

ITEMS UNDER TEST

Head, rocket, spotting charge (red), 2.75-inch, T2026, lots PA-E-51008 and PA-E-51010.

Warhead, 2.75-inch rocket, HE, red marker, XM152, lots PA-E-51009 and PA-E-51011.

SUPPORTING FACILITIES AND MATERIALS

Ammunition:

Fuze, rocket, XM423E1, lot ENW-63-13, (loaded 10-64), for 2.75-inch FFAR rocket.

Fuze, rocket, Mk 178, Mod 0, lot HMC3, loaded 2-54.

Motor, rocket, for 2.75-inch FFAR rocket, Mk 40, lot RMHA-238-5-53A (full scarf).

Launcher:

Armament subsystem XM3, mounted on UH-1B helicopter.

Facilities:

Cameras, motion picture, 16-mm color.

Helicopters, UH-1B, one for observation of the rocket impacts and one for firing rockets.

DETAILS OF TEST

Because of the inconsistent quality of smoke clouds observed during engineering design tests of the XM152 and XM153 target-marker warheads (ref FR R-3574), a comparison test (under tactical conditions) of the XM152 and T2026 warheads was prescribed by the test directive.

All rounds were fired from the UH-1B helicopter employing the XM3 armament subsystem, while flying at a speed of approximately 60 knots. The test rounds were fired singly. This was achieved by leaving alternate tubes open when loading the rounds into the XM3 rocket launcher modules. The first 20 rounds were fired into an open field; the remaining 20 rounds were fired into a wooded area.

Photographic coverage of warhead function and smoke cloud produced was provided by two 16-mm color motion-picture cameras. One camera was located on the ground approximately 1300 meters from the impact area and the other camera was located in a UH-1B helicopter positioned approximately 1000 meters from the impact area.

Duration of smoke clouds was taken with a stop watch by ground observers who were located about 1000 meters from the impact area.

Surface meteorological data were taken at the test site at the time of firing each round.

SUMMARY OF RESULTS

	Smoke Cloud Duration, sec.	
	T2026 Warhead	XM152 Warhead
Average duration for rounds impacting in open field or swamp.	7.23(10)	3.17(9)
Average duration for rounds impacting in wooded areas.	28.7(6)	25.3(9)

Note: The figures in parentheses indicate the numbers of rounds considered in the average. Rounds 6, 21, 23, 35, 39, and 40 were not considered.

Both types of warheads showed the same variation in smoke cloud performance characteristics when fired into open field areas; however, the T2026 warhead had better overall smoke cloud characteristics, when fired against this terrain, than did the XM152 warhead.

Both types of warheads showed improved functioning and smoke cloud characteristics when fired into wooded areas.

Results of the firings of the two types of warheads into wooded areas were about the same.

OBSERVATIONS AND REMARKS

The more satisfactory functioning and smoke cloud produced when both types of warheads were fired into wooded areas may be a result of the following:

- a. The smoke emitted by the two types of warheads can be partially defeated by dust or dirt kicked up by the round impact or detonation of the warhead in open fields. Also, water in the swamps tends to decrease the amount of smoke emitted. These observations are borne out by the results of other test firings (ref Fr R-3574).
- b. The woods tend to prevent rapid dissipation of the smoke clouds by the ground winds.

BLANK PAGE

APPENDIX E

Engineer Design Test of XM153 Color Marker Warhead,
with XM423 Fuze and Fuze Extension

ABERDEEN PROVING GROUND
ABERDEEN PROVING GROUND, MARYLAND 21005
FIRING RECORD R-3643
(Dates of Test: 1 to 26 July 1965)

ITEM UNDER TEST

Warhead, 2.75-inch, yellow marker, XM153, with fuze, PD, XM423E1, lot PA-E-51427, and extension, fuze, for color marker warhead, lot PA-E-51797.

SUPPORTING FACILITIES AND MATERIALS

Ammunition:

Motor, rocket, 2.75-inch FFAR, Mk 40, lot RMHA 275A-S-53.

Weapon:

Carriage, howitzer, 75-mm, with adapter for launcher tubes from the XM3 helicopter armament subsystem.

Firing Device:

Firing box, T3.

Facilities:

Camera, motion picture, 16-mm.

Target:

Earth, trees, and water.

DETAILS OF TEST

This test was performed in accordance with the test directive, AMSTE-BG, 10 May 1965 and letter, SMUPA-VL2, 30 April 1965.

This report contains the results of a comparison test firing of the 2.75-inch FFAR, Mk 40 rocket motor and the XM153 color marker warhead assembled with an XM423E1 fuze, and with an XM423E1 fuze and a 7-inch-long fuze extension to determine the effectiveness of the fuze extension for producing larger and better quality smoke clouds.

The 7-inch fuze extension, containing RDX explosive, was inserted between the color marker warhead (XM153) and the fuze (XM423E1) to permit detonation of the color marker warhead above the target surface. This test was fired in the sequence outlined in the directive, SMUPA-VL2, paragraphs 3 and 4, except that the samples with and without the fuze extensions were reversed.

The warhead functioning data were recorded on color film by a 16-mm motion picture camera positioned approximately 90° to the line of fire and at the impact area. Warhead functioning data were also recorded by the same method from a helicopter hovering about 300 feet above and to the right side of the impact area.

The color film, containing these data, were reviewed and then forwarded to Picatinny Arsenal.

SUMMARY OF RESULTS

No. Rds Tested	No. Rds Functioning on Impact		No. Rds that Failed to Function	Remarks
	Without Fuze Extension	With Fuze Extension		
Ground Impact Phase				
30	15	15	0	There was no visual difference in the warhead functioning and the smoke cloud produced.
Tree Impact Phase				
12	5	6	1	There was no visual difference in the warhead functioning and the smoke cloud produced.
Water Impact Phase				
18	5	6	^a 7	These rounds seemed to function on or just below the water surface, resulting in very poor smoke clouds.

^aTwo of these rounds impacted the ground between 300 and 400 feet from the launcher and all warhead functioning data were lost.

OBSERVATIONS AND REMARKS

The camera film indicated that the rounds with the fuze extension produced a slightly better smoke cloud on the earth target than the rounds without a fuze extension. A frame-by-frame observation revealed that 11 of 15 samples that functioned on ground impact produced slightly larger and higher smoke clouds and the smoke clouds formed more quickly than those of the 15 samples without the fuze extension. However, visual observation revealed no significant difference in the smoke clouds. The remaining four samples appeared to function as normal XM153 warheads without the fuze extension.

The camera film also indicated that the rounds with and without the fuze extension produced similar types of smoke clouds on tree targets and on water targets. However, the rounds fired on the water target produced a very poor quality smoke cloud. It is believed that the rounds fired on the water target functioned below the surface of the water.

The fuze and warhead of one round in the tree impact phase and seven rounds in the water impact phase failed to function. Two of the seven rounds in the water impact phase impacted the ground approximately 300 to 400 feet in front of the launcher and the warhead did not function. The reason for these short flight rounds is unknown.

In general, the fuze extension produced no significant improvement (visual observation and camera film) in the size and quality of the smoke cloud of the XM153 color marker warhead.

FUTURE RELATED WORK

No further testing of the fuze extension is anticipated.

SUBMITTED:

GEORGE S. MURRAY
Test Director

REVIEWED:

MARSHALL T. SMITH
Chief, Rocket and Missile
Branch

FOR THE COMMANDER:

CLAUDE E. BROWN
Chief, Infantry and
Aircraft Weapons Division
Development and Proof Services

UNCLASSIFIED
Security Classification

DOCUMENT CONTROL DATA - R&D		
<i>(Security classification of title, body of abstract and indexing annotation must be entered when the overall report is classified)</i>		
1. ORIGINATING ACTIVITY (Corporate author)		2a. REPORT SECURITY CLASSIFICATION
Picatinny Arsenal, Dover, N. J.		Unclassified
		2b. GROUP
3. REPORT TITLE		
DEVELOPMENT OF COLOR MARKER HEADS FOR THE 2.75-INCH ROCKET		
4. DESCRIPTIVE NOTES (Type of report and inclusive dates)		
5. AUTHOR(S) (Last name, first name, initial)		
Kliem, Bernd, Sp6, Andrews, J. E., Jr., Bessey, G. P.		
6. REPORT DATE	7a. TOTAL NO. OF PAGES	7b. NO. OF REFS
February 1966	69	
8a. CONTRACT OR GRANT NO.	9a. ORIGINATOR'S REPORT NUMBER(S)	
b. PROJECT NO. AMCMS Code 4810.16.363112	Technical Report 3316	
c.	9b. OTHER REPORT NO(S) (Any other numbers that may be assigned this report)	
d.		
10. AVAILABILITY/LIMITATION NOTICES		
Distribution of this document is unlimited.		
11. SUPPLEMENTARY NOTES		12. SPONSORING MILITARY ACTIVITY
13. ABSTRACT		
<p>Development of the XM152 red marker warhead and XM153 yellow marker warhead for the 2.75 inch Folding Fin Aircraft Rocket (FFAR) was successfully accomplished in eight weeks. This report presents the results of static tests conducted at Picatinny Arsenal and ballistic tests at other installations during this program and in related investigations.</p> <p>Because of time limitations, many phases of the investigation could not be carried out as thoroughly as might perhaps have been desired. Nevertheless, a workable item was developed, and a cost savings of \$627,000 (for FY 65) was realized. The ideas tried are presented here together with relevant test results. A sketch of the color marker warhead configuration adopted by the Army and a copy of the accompanying specifications are included in the report.</p>		

DD FORM 1473
1 JAN 64

UNCLASSIFIED
Security Classification

14. KEY WORDS	LINK A		LINK B		LINK C	
	ROLE	WT	ROLE	WT	ROLE	WT
Pyrotechnics Color marker warheads Red color marker Target marker Implosion-type warhead Proximity fuze Smoke duration Smoke volume XM152 red color marker XM153 yellow color marker Dye-salt slurry						

INSTRUCTIONS

1. **ORIGINATING ACTIVITY:** Enter the name and address of the contractor, subcontractor, grantee, Department of Defense activity or other organization (*corporate author*) issuing the report.

2a. **REPORT SECURITY CLASSIFICATION:** Enter the overall security classification of the report. Indicate whether "Restricted Data" is included. Marking is to be in accordance with appropriate security regulations.

2b. **GROUP:** Automatic downgrading is specified in DoD Directive 5200.10 and Armed Forces Industrial Manual. Enter the group number. Also, when applicable, show that optional markings have been used for Group 3 and Group 4 as authorized.

3. **REPORT TITLE:** Enter the complete report title in all capital letters. Titles in all cases should be unclassified. If a meaningful title cannot be selected without classification, show title classification in all capitals in parenthesis immediately following the title.

4. **DESCRIPTIVE NOTES:** If appropriate, enter the type of report, e.g., interim, progress, summary, annual, or final. Give the inclusive dates when a specific reporting period is covered.

5. **AUTHOR(S):** Enter the name(s) of author(s) as shown on or in the report. Enter last name, first name, middle initial. If military, show rank and branch of service. The name of the principal author is an absolute minimum requirement.

6. **REPORT DATE:** Enter the date of the report as day, month, year; or month, year. If more than one date appears on the report, use date of publication.

7a. **TOTAL NUMBER OF PAGES:** The total page count should follow normal pagination procedures, i.e., enter the number of pages containing information.

7b. **NUMBER OF REFERENCES:** Enter the total number of references cited in the report.

8a. **CONTRACT OR GRANT NUMBER:** If appropriate, enter the applicable number of the contract or grant under which the report was written.

8b, 8c, & 8d. **PROJECT NUMBER:** Enter the appropriate military department identification, such as project number, subproject number, system numbers, task number, etc.

9a. **ORIGINATOR'S REPORT NUMBER(S):** Enter the official report number by which the document will be identified and controlled by the originating activity. This number must be unique to this report.

9b. **OTHER REPORT NUMBER(S):** If the report has been assigned any other report numbers (*either by the originator or by the sponsor*), also enter this number(s).

10. **AVAILABILITY/LIMITATION NOTICES:** Enter any limitations on further dissemination of the report, other than those imposed by security classification, using standard statements such as:

- (1) "Qualified requesters may obtain copies of this report from DDC."
- (2) "Foreign announcement and dissemination of this report by DDC is not authorized."
- (3) "U. S. Government agencies may obtain copies of this report directly from DDC. Other qualified DDC users shall request through _____."
- (4) "U. S. military agencies may obtain copies of this report directly from DDC. Other qualified users shall request through _____."
- (5) "All distribution of this report is controlled. Qualified DDC users shall request through _____."

If the report has been furnished to the Office of Technical Services, Department of Commerce, for sale to the public, indicate this fact and enter the price, if known.

11. **SUPPLEMENTARY NOTES:** Use for additional explanatory notes.

12. **SPONSORING MILITARY ACTIVITY:** Enter the name of the departmental project office or laboratory sponsoring (*paying for*) the research and development. Include address.

13. **ABSTRACT:** Enter an abstract giving a brief and factual summary of the document indicative of the report, even though it may also appear elsewhere in the body of the technical report. If additional space is required, a continuation sheet shall be attached.

It is highly desirable that the abstract of classified reports be unclassified. Each paragraph of the abstract shall end with an indication of the military security classification of the information in the paragraph, represented as (TS), (S), (C), or (U).

There is no limitation on the length of the abstract. However, the suggested length is from 150 to 225 words.

14. **KEY WORDS:** Key words are technically meaningful terms or short phrases that characterize a report and may be used as index entries for cataloging the report. Key words must be selected so that no security classification is required. Identifiers, such as equipment model designation, trade name, military project code name, geographic location, may be used as key words but will be followed by an indication of technical context. The assignment of links, rules, and weights is optional.