

AD

# USAAVLABS TECHNICAL REPORT 66-12

## LF-2

### LIGHTWEIGHT LIFT FAN FRONT FRAME DESIGN

AD 634104

CLEARINGHOUSE FOR FEDERAL SCIENTIFIC AND TECHNICAL INFORMATION			
Hardcopy	Microfiche		
\$ 4.00	\$ 1.00	106 pp	FX
ARCHIVE COPY			

May 1966

U. S. ARMY AVIATION MATERIEL LABORATORIES  
FORT EUSTIS, VIRGINIA

CONTRACT DA 44-177-AMC-45(T)  
GENERAL ELECTRIC COMPANY  
CINCINNATI, OHIO

Distribution of this  
document is unlimited.



### Disclaimers

The findings in this report are not to be construed as an official Department of the Army position unless so designated by other authorized documents.

When Government drawings, specifications, or other data are used for any purpose other than in connection with a definitely related Government procurement operation, the United States Government thereby incurs no responsibility nor any obligation whatsoever; and the fact that the Government may have formulated, furnished, or in any way supplied the said drawings, specifications, or other data is not to be regarded by implication or otherwise as in any manner licensing the holder or any other person or corporation, or conveying any rights or permission, to manufacture, use, or sell any patented invention that may in any way be related thereto.

### Disposition Instructions

Destroy this report when no longer needed. Do not return it to originator.



**DEPARTMENT OF THE ARMY**  
**U. S. ARMY AVIATION MATERIEL LABORATORIES**  
**FORT EUSTIS, VIRGINIA 23604**

This report has been reviewed by the U. S. Army Aviation Materiel Laboratories and is considered to be technically sound. The report is offered for the exchange and dissemination of information pertaining to lightweight lifting fan propulsion systems.

Task 1M121401D14409  
Contract DA 44-177-AMC-45(T)  
USAAVLABS Technical Report 66-12  
May 1966

**LF-2**  
**LIGHTWEIGHT LIFT FAN FRONT FRAME DESIGN**

Prepared by  
GENERAL ELECTRIC COMPANY  
Flight Propulsion Division  
Cincinnati, Ohio

For  
U. S. ARMY AVIATION MATERIEL LABORATORIES  
FORT EUSTIS, VIRGINIA

Distribution of this  
document is unlimited

## SUMMARY

The design, the manufacturing problems and their solutions, and the limited testing of a new bolted component assembled lightweight front frame for a tip turbine lift fan are discussed. This new frame was necessary for compatibility with a new lightweight improved critical speed response rotor design and to replace the present X353-5B front frame which is used in the General Electric Company's XV-5A Lift Fan Flight Research Program with a lighter weight and lower cost unit.

The front frame is subdivided into eight separate components made from four different materials. The materials for each component were: cast A356 aluminum for the 73.78-inch-long major strut and the 31.72-inch-long minor strut; wrought Al10AT titanium for the dome bracket and the 32.5-inch-radius hot- and cold-side sectors; reinforced fiber glass plastic for the 25-inch-diameter dome; and wrought and cast 17-4 PH steel for the hub and integral minor strut and strut end caps. Actual tensile specimen data taken from the castings and the results of the simulated weld joint of cast to wrought 17-4 PH material are tabulated in the Material section. The weld joint strength and ductility obtained using the 1025<sup>o</sup>F age cycle are exceptional and this combination of wrought to cast 17-4 PH steel should be given serious thought in all future designs.

The functions, description, design considerations, and stresses are discussed for each component.

The frame component weights as calculated have been tabulated, and a comparison of the summation of the component calculated weights of 99.6 pounds versus the actual pan weight of 103 pounds is discussed.

Manufacturing problems encountered and resulting solutions were: 1) weld distortion and cracking of the 0.015-inch-thick gussets which were stiffened to remove excessive warpage; 2) splitting of the large 0.030-inch-thick titanium spinnings which were increased to 0.06 inch along with an increase in the spinning chuck rpm to produce a good part; 3) puckering inward of the thin walls of the large cast aluminum struts during quenching operation which was eliminated by the use of hollow tubing providing a passage for air to enter the strut cavity equalizing pressures across the wall.

The frame was tested to 100-percent rotor speed loading as a component part of the LF-2 lift fan assembly. Limited operating data were obtained because of test termination resulting from turbine bucket shroud damage.

## FOREWORD

This report describes the mechanical design and manufacture of the LF-2 lightweight lift fan front frame. The work was conducted by the Lift Fan Systems Operation of the Flight Propulsion Division of the General Electric Company, Evendale, Ohio, under U. S. Army contract DA 44-177-AMC-45(T). The project engineer was Mr. R. T. Haenel and the design engineer was Mr. G. Webb.

**BLANK PAGE**

## CONTENTS

	<u>Page</u>
SUMMARY . . . . .	iii
FOREWORD . . . . .	v
LIST OF ILLUSTRATIONS . . . . .	viii
LIST OF TABLES . . . . .	xii
INTRODUCTION . . . . .	1
DESIGN CRITERIA . . . . .	4
MATERIAL . . . . .	7
MOUNTING . . . . .	18
LAYOUT INTENT . . . . .	19
Major Strut (12 to 6 O'clock) . . . . .	20
Nine O'clock Strut . . . . .	23
Hub and 3 O'clock Strut . . . . .	25
Dome . . . . .	32
Hot-Side Sectors . . . . .	35
Cold-Side Sectors . . . . .	38
Strut End Caps . . . . .	41
Bracket-Dome Mounting . . . . .	44
WEIGHT . . . . .	46
MANUFACTURING PROBLEMS AND THEIR SOLUTIONS . . . . .	47
TESTING . . . . .	54
CONCLUSIONS AND RECOMMENDATIONS . . . . .	55
DISTRIBUTION . . . . .	56
APPENDIXES	
I. Figures 1 Through 51 . . . . .	57
II. Supplement Material Instructions . . . . .	118

## ILLUSTRATIONS

<u>Figure</u>		<u>Page</u>
1	Comparison of 0.2 Percent Yield Versus Temperature for Various Alloys .....	57
2	Room Temperature Tensile Properties of 17-4 PH Material Conditioned for 1 Hour at 1025 <sup>o</sup> F .....	58
3	Plane View of LF-2 Front Frame Showing its Mounting and Restraint at Each Mount .....	58
4	Drawing 4012001-386, Hub and Minor Strut 3 O'clock LF-2 Front Frame .....	59
5	Drawing 4012001-379, Assembly, Front Frame LF-2 .....	63
6	VIOL LF-2 Front Frame Components; Reinforced Glass Plastic Dome Not Shown; Assembled Frame is 6 Feet in Diameter .....	65
7	Drawing 4012001-380, Major Strut 12 to 6 O'clock Front Frame LF-2 .....	67
8	Drawing 4012001-381, Minor Strut 9 O'clock LF-2 Front Frame .....	69
9	Drawing 4012001-383, Dome - Front Frame LF-2 .....	71
10	Drawing 4012001-385, Sectors 12 to 3 and 3 to 6 O'clock, Front Frame LF-2 .....	73
11	Drawing 4012001-384, Sector 6 to 12 O'clock Front Frame LF-2 .....	75
12	Drawing 4012001-382, End Caps 12 to 6 O'clock Struts Front Frame LF-2 .....	77
13	Drawing 4012001-337, Bracket Front Frame LF-2 .....	79
14	LF-2 Front Frame View Showing Completed Frame and Assembly Tooling at the Manufacturing Source. The Machined Test, 3 O'clock A286 Support Beam is Shown Attached to the 3 O'clock Strut End .....	81

<u>Figure</u>		<u>Page</u>
15	LF-2 Front Frame View Showing Frame in Inverted Position .....	82
16	Worst Loading Condition of Major Strut with Gyro Reacted by the 3 O'clock Strut .....	83
17	Shear and Bending Moment Diagram Showing Maximum Worst Loading on Major Strut When the 2 Rad/Sec Gyro is Reacted by the 3 O'clock Strut, Reference Figure 16 .....	84
18	Worst Loading Condition of Major Strut With Gyro Reacted by the Major Strut .....	85
19	Shear and Bending Moment Diagram Showing Maximum Worst Loading on Major Strut When 1.4 Rad/Sec is Reacted by Major Strut .....	86
20	Sectional Properties of 12 to 6 O'clock Strut .....	87
21	LF-2 Front Frame View Showing Attachment of the All0AT Titanium Cold-Side Sector and 17-4 PH End Cap to the 12 to 6 O'clock Cast A356T1 Aluminum Strut .....	88
22	LF-2 Front Frame View Showing the Attachment of the 12 to 6 O'clock and 9 O'clock Cast A356 Aluminum Struts to the Cast 17-4 PH Hub. Also Shown is the Attachment of the 9 O'clock Dome Mounting Bracket to the 9 O'clock Strut and Hub.....	89
23	LF-2 Front Frame View Showing the Cast 17-4 PH Hub With its Integral Fabricated 17-4 PH Strut; Also Shown is the Attachment of the 3 to 6 O'clock Hot-Side Sector to the 3 O'clock Strut and the 3 O'clock Strut Support Beam Attachment .....	90
24	LF-2 Front Frame View Showing the Attachment of the 9 O'clock Cast A356T1 Aluminum Strut to the All0AT Titanium Cold-Side Sector. Also Shown is the Speed Pickup Housing Attaching Boss .....	91
25	Sectional Properties of 9 O'clock Strut .....	92

<u>Figure</u>		<u>Page</u>
26	Load, Shear, and Bending Moment Diagram for the 9 O'clock Strut .....	93
27	View Showing Cross Section of Hub In-plane of Major Strut for the Purpose of Identifying its Integral Component Parts .....	94
28	View Showing Hub Normal to 3 O'clock Strut for Purpose of Identifying the Hub Shaft Integral Component Parts .....	95
29	Cross-Sectional Properties and Load Diagram of the Shaft Portion of the Hub With 200,000 Pound- Inches of Gyro Reacted by the 3 O'clock Strut .....	96
30	Loading, Shear, and Moment Diagram for the 3 O'clock Strut for Reacting 2 Rad/Sec Gyro .....	97
31	Cross-Sectional Properties of the 3 O'clock Strut .....	98
32	LF-2 Front Frame Epoxy Glass Laminate Dome - 9 O'clock Half .....	99
33	LF-2 Front Frame Epoxy Glass Laminate Dome - 9 O'clock Half View Showing the Rib Structure ....	100
34	Dome Mounting and Pressure Loading .....	101
35	Assumed Running Loading on Quarter Dome Rib Structure Due to a 1.17-psi Pressure Rise in Dome Cavity .....	102
36	Quarter Dome Mounting Reactions for Design of a 1.17-psi Rise in the Dome Cavity .....	103
37	Showing Typical Joint Construction Used in the Manufacturing of the Dome .....	104
38	Showing Typical Star Lay-up over Rib Junctions Reinforcing the Joint .....	105
39	Dome Maximum Stresses and Approximate Location Showing Only Those Stresses of 900 psi and Higher .....	106

<u>Figure</u>		<u>Page</u>
40	LF-2 Front Frame View Showing Attachment of the 12 to 3 O'clock All0AT Titanium Hot-Side Sector to the 17-4 PH End Cap .....	107
41	View Showing Hot-Side Sector Tube to End Attachment Flange Construction .....	108
42	LF-2 75.26-Inch-Diameter Front Frame View Showing Component Subassemblies and Their Materials; the Dome Which is an Epoxy Fiber Glass Lay-up is not Shown .....	109
43	Photomicrograph (500X -Etched) Showing Cracked Surface in All0AT 0.030-Inch Titanium Sheet Which Failed During the Cold-Side Tube Spinning Operation .....	110
44	Gating Layout for Green Sand Casting of the 9 O'clock A356 Aluminum Strut .....	111
45	Gate Layout Used in Green Sand Mold for Casting the A356 Aluminum Major 12 to 6 O'clock Strut .....	112
46	Core Hole Closure of the A356 Aluminum Strut Wall Showing Plug and Problem Requiring Repair .....	115
47	Major 12 to 6 O'clock A356 Aluminum as Cast Strut Showing Problem Areas, Gas Catcher Locations, Size, and Core Holes .....	114
48	LF-2 Fan Assembly Removal From Test Facility Upon Termination of the 100-Percent Speed Checkout. The Epoxy Glass-Cloth Dome is Shown. A Front Frame to Rear Frame Adapter Spacer is Removed for Visual Inspection of Turbine Bucket Shrouds .....	115
49	Showing Crack Locations in Weld Affected Zone of the Cold-Side Gusset, 0.015-Inch Stock All0AT Titanium Which Developed During Test .....	116
50	Showing Proposed Extension of the Inner Leg Flange to Improve Efficiency of Gusset to Remove Stress Concentration Area .....	117
51	Showing Location of Front Frame Thermocouples and Their Output for Various Fan Speeds .....	118

TABLES

<u>Table</u>		<u>Page</u>
1	Mechanical Properties of A356T6 (AMS 4218A) Versus C355T6 (AMS 4215A) .....	8
2	Tensile Specimen Results for the A356 Alloy Major Strut per Drawing 4012001-380 .....	9
3	Tensile Specimen Results for the A356 Alloy 9 o'clock Strut per Drawing 4012001-381 .....	10
4	Results of Physical Tests of Flat Laminate Panel (0.032 Inch Thick) 181-150 ERL 2256 Resin .....	13
5	Room Temperature Tensile Properties of Specimens Taken From the LF-2 17-4 PH Cast Hub .....	15
6	Room Temperature Tensile Properties Taken From a Second 17-4 PH Casting After Mold Changes Were Made to Improve the Ductility Found Below Specification Limits in the First Casting (see Table 5) .....	16
7	Room Temperature Tensile Data of 17-4 PH Cast to Wrought Weld Specimens .....	17

## INTRODUCTION

The present X353-5B lift fan was successfully demonstrated as a reliable and efficient vertical lift component under the Army XV-5A Lift Fan Flight Research Program, contract DA 44-177-TC-715. However, the fan as initially designed has several limitations:

1. The fan overspeed capability is limited to 103.5-percent fan speed and preventing full utilization of fan thrust capability.
2. The rotor presents a two per revolution response at  $\approx 2000$  rpm which falls within the fan speed operating range. The induced stresses are tolerable but at the expense of maximum load capacity.
3. The dimensional envelope of the present fan front frame compromises wing design as to thinness and taper.

To improve the rotor characteristics as to critical speed response and overspeed capability, a new lighter weight rotor was designed. This new design is based on X376 developed technology and general configuration, the configuration differences being

1. Integral front frame and shaft.
2. Bearings located in rotor disc with outer race rotating.
3. Thicker disc hub, spacing the bearings for acceptable loading.

To obtain the lowest cost and lightest weight design, symmetry about the plane of rotation which affected a 0.188 elevation rise of the rotor plane was essential. These changes in the rotor configuration made it mandatory to redesign the front frame to provide axial operating clearances.

The present front frame being an integral ring and strut hub structure presents manufacturing and heat treating problems which add to its cost and reduce maintainability. These problems arise from the largeness of the front frame structure, the material used, and the involved heat treatment. To eliminate these difficulties, the new concept of an assembled front frame consisting of particular components with the following advantages was conceived:

1. Smaller Structures: The frame assembly can be broken up into a number of components varying in geometry and fitting the facilities of a greater number of potential manufacturers.

2. Selective Use of Materials: In integral weldment-type structure, only one material can be used if the part is to be heat-treated. With the component structure, bolted or riveted together, different materials may be utilized, making full use of their characteristics.
3. Selective Processes: Different parts of the structure, requiring different degrees of strength, can now be heat-treated separately without affecting adjacent structure.
4. Improved Maintainability: If damage or failure of any component part happens, the part can be replaced without affecting the alignment of the balance of the structure.
5. Lighter Weight: Through the selective use of materials, structural weight can be minimized.
6. Ease of Modification: Any one component or combinations thereof can be easily redesigned and assembled to the balance of the structure affecting development growth.
7. Lower Production Costs: Utilization of the competitive manufacturing market, by causing the greater number of potential manufacturers minimum production costs, can be obtained.

A discussion of the design and manufacture of this lightweight front frame follows.

#### DESIGN OBJECTIVES

In the design of the LF-2 front frame, the prime design objectives were as listed below:

1. The rotor shall be cantilevered from a fixed shaft integral with the front frame similar to that of the X376.
2. Transverse inlet louver mounting shall not be provided.
3. Front frame shall be cast or fabricated with four struts equally spaced. Spanwise struts and bullet nose shall not protrude above the wing. Chordwise strut may protrude.
4. Front frame shall be compatible with a tapered wing of decreasing thickness with span.
5. Front frame mounting shall be the same as that of the XV-5A fans.

6. The frames shall not have a bellmouth, therefore, compatible with various wing sections. Bellmouth is to be an airframe part for best integration with wing design.
7. The front frame shall be interchangeable in order to accommodate a left- and right-wing fan installation.
8. The weight shall not exceed 100 pounds.
9. A nonintegrated, bolted construction shall be employed wherever possible to reduce manufacturing cost and simplify shipping and stocking (e.g., front frame is not single weldment).
10. The frame configuration shall be compatible with the new LF-2 rotor and with the old X353-5 scroll and rear frame (with minor alterations). This requires the cold side tunnel flange bolt circle diameter and casing internal diameter to remain equal to that of the X353-5 rear frame.
11. Provisions shall be made for attaching the inlet vane to the struts in the same way as that of the X353-5B.
12. Provisions shall be made for routing instrumentation leads from the center of the front frame hub.
13. The component of axial deflection of the rotor forward seal lip due to the stiffness of the shaft shall be 0.060 inch maximum.
14. Axial clearances shall be the same as that for the XV-5A where possible.
15. Provisions for mounting a speed pickup housing similar to the X376 shall be provided.
16. No provisions shall be made for inlet door mounting. However, the design shall be capable of being modified to mount the inlet doors.
17. The frame shall be capable of supporting the additional rotor lift associated with a rotor 115-percent overspeed condition.

## DESIGN CRITERIA

### FAN PERFORMANCE

The criteria are identical to those for the X353-5B fans except the areas of fan and turbine performance which were changed to increase fan performance.

SLS 100-Percent Rotor Speed	2761 RPM
Fan Turbine Flow	40.05 lb/sec
Fan Flow	546.6 lb/sec
Fan Pressure Ratio	1.1227
Fan Turbine Inlet Temperature	1801 <sup>o</sup> R
Fan Turbine Inlet Pressure	34.04 psia
Fan Inlet Temperature	519 <sup>o</sup> R
Fan Tip Diameter	62.5 inches
Fan Root Diameter	25 inches
Bucket Tip Diameter	71.872 inches (cold)
Bucket Root Diameter	65.666 inches (cold)
Turbine Arc Admission	160 degrees

### MISSION REQUIREMENTS

Mission	Flight Speed (knots)	Altitude (feet)	Life (hours)	Fan Speed (%)	T <sub>5</sub> * ( <sup>o</sup> F)
Military	0 - 160	0	200	100	1341
	0	0	200	95	1245
	0	0	400	90	1175
Qualification Test	0	0	10	40	Idle
			10	95	Normal
			30	100	Continuance Maximum**

\*At military conditions there is a variation of  $\pm 40^{\circ}\text{F}$  in holding T<sub>4</sub>. This is assuming an error of  $\pm 10^{\circ}\text{F}$  in the controls and an error of  $\pm 30^{\circ}\text{F}$  for T<sub>5</sub> thermocouples.

\*\*100-percent speed is at 2761 fan speed.

### MISCELLANEOUS REQUIREMENTS

In addition to the mission requirements, the fan shall be capable of the following:

<u>Mission</u>	<u>Flight Speed (knots)</u>	<u>Altitude (feet)</u>	<u>Life (hours)</u>	<u>Fan Speed (%)</u>	<u>T<sub>5</sub>* (°F)</u>
Sea-Level Hot Day	160	0	20	113	1343

### MANEUVER LOADS (Per MIL-S-5705)

<u>Condition</u>	<u>Load Factor (g's)</u>			<u>Angular Velocity for Gyrocouples (Rad/Sec)</u>		
	<u>Vertical</u>	<u>Side</u>	<u>Fore or Aft</u>	<u>Pitch</u>	<u>Roll</u>	<u>Yaw</u>
Turn	3.0 up or 7.5 down	2.0	1.0	1.4*	1.4*	0.5
Spin	1.5 up or 3.75 down	1.0	0.5	1.4*	1.4*	3.5

Landing - Ultimate Load Factors for Engine Mount:

Landing	2.0 up or 4.5 down	1.5	8	0	0	0
Static	1.5 down (Fan Shipment)					

\*Pitch and roll together can total 2.0 rad/sec and is a General Electric Company requirement. MIL-S-5705 requires 1.0 for pitch only and neglects roll because the axis of the rotation produces no roll gyro loads in turbojets.

### GENERAL DESIGN LIMITS

Engine parts may be divided into two general classes, depending upon the relative importance of vibratory stresses. It is certain that all parts are subjected to some oscillatory loads, but for most parts other than blades, buckets, and stator vanes, the criteria established for steady-state stresses or short-time stresses due to maneuvers will govern the design.

## STATIC PARTS

Parts in which vibratory stresses are of minor importance are governed by the stress limits which follow:

### Steady-State Loads

Stress levels are to be determined by whichever is lower:

1. 100 percent of 0.002 offset yield strength.
2. 100 percent of 0.002 plastic creep strength.
3. 80 percent of stress rupture strength.

These stress values are to be obtained in the following manner:

1. Material curves, which give average values, are to be reduced by the material deviation factor which is determined from the spread in material data.
2. The time in hours is as specified by the mission requirements.
3. The temperature is to be determined from the cycle data, and in all cases a temperature deviation is to be considered in the design of the part. The magnitude of the temperature deviation should depend upon the sensitivity of the part to temperature changes and the accuracy of the analysis.
4. Thermal fatigue and transients should be considered by increasing the design life. For parts which undergo severe temperature cycling, the life should be increased by a factor of two.

### Maneuver Loads

Short-time properties (yield or ultimate) shall be used for the appropriate load conditions specified in the Maneuver Load section.

## MATERIAL

The four materials used in the manufacture of the lightweight front frame were:

1. Cast aluminum alloy A356
2. AL10AT titanium
3. Reinforced fiber glass plastic
4. Wrought and cast 17-4 PH steel

Their properties and reasons for selection are as follows:

1. The selection of A356 over C355 for the cast aluminum strut was to obtain a higher level of ductility with little loss in strength. Table 1 lists the comparative tensile properties of these two alloys.

The selection was justified on three accounts:

- a. The casting vendor would not guarantee 2-percent elongation with C355 alloy but would with A356 alloy.
- b. The experience of other General Electric projects using C355 alloy where elongations of zero to 1 percent were obtained.
- c. A356 alloy is 50 percent less brittle than C355 alloy with only a 9 percent lowering of the ultimate strength.

Fatigue data for both alloys show A356 and C355 to be comparable alloys with 8500 psi and 9000 psi for  $5 \times 10^8$  cycles, respectively, for sand castings. The acceptance standard for the casting material is per "Instructions LF-2 Aluminum Cast Strut A-4012154-967", Appendix II. The test results for the major 12 to 6 o'clock strut casting in compliance with the instruction for separately cast bars, the requested casting minimum, the specimens taken from the casting, the specimen taken directly beneath the leading edge gas catcher, and the comparison of the effect of gas in excess of limits in the strut walls are tabulated in Table 2. In all the cases, the material properties met or exceeded the requirements. The test results for the 9 o'clock strut casting in compliance with the instruction are tabulated in Table 3.

TABLE 1

## MECHANICAL PROPERTIES OF A356T6 (AMS 4218A) VERSUS C355T6 (AMS 4215A)

<u>Specification Minimums</u>		
	<u>C355T6</u> <u>(AMS 4215A)</u>	<u>A356T6</u> <u>(AMS 4218A)</u>
Separately Cast Bars:		
Ultimate (psi)	37,000	33,000
0.2 YS (psi)	30,000	27,000
% Elongation	1.0	3.0
Casting Any Area:		
Ultimate (psi)	35,000	32,000
0.2 YS	28,000	22,000
% Elongation	2.0	2.0
<u>Typical Cast Bars (Oberdorfer Data)</u>		
	<u>C355T6</u> <u>(AMS 4215A)</u>	<u>A356T6</u> <u>(AMS 4218A)</u>
Ultimate (psi)	45,000	40,000
0.2 YS	33,000	30,000
% Elongation	4.5	5.0
	<u>355T6 SC*</u>	<u>356T6 SC*</u>
Compressive 0.2 YS	26,000	25,000
Brinell Hardness 500 KG Load	80	70
Shearing Strength	28,000	26,000
Density	0.098 lb/cu in	0.097 lb/cu in
Modulus	10.3 x 10 <sup>6</sup>	10.3 x 10 <sup>6</sup>
Bearing Strength		59,000 Ultimate 40,000 Yield

\* Sand Casting

**TABLE 2**  
**TENSILE SPECIMEN RESULTS FOR THE A356 ALLOY MAJOR STRUT**  
**PER DRAWING 4012001-380**

Specimen	Tensile (psi)	Yield (psi)	Elongation Percent in 2 Inches	
Separately Cast Bars Typical	42,700	35,200	5.0	
Requested Casting Minimums:				
Caps	33,000	25,000	2.0	
Walls	30,000	20,000	2.0	
Test Bar Results Taken From Casting:				
1	43,000	32,400	5.0	
2	38,600	33,100	5.0	
3	41,800	33,500	5.0	
4	42,900	33,300	7.0	
5	43,400	35,300	5.0	
6	42,400	32,900	3.5	
7	41,100	33,000	3.5	
8	41,600	32,600	3.5	
9	33,000	30,200	4.0	
10	41,100	33,400	4.5	
11	39,100	29,800	4.0	
12	34,000	27,800	3.0	
13	43,100	34,000	5.0	
14	41,100	33,400	5.0	
15	44,500	35,000	7.0	
16	44,700	33,800	7.0	
17	33,500	26,800	3.0	
18	36,600	31,900	3.0	
19	39,100	33,000	2.5	
20	38,500	29,500	4.0	
Taken From Leading Edge Directly beneath the Gas Catcher:				
1	42,600	37,100	2.5	
Taken From the Walls of Casting No. 6 for Effect of Gas Holes Which Exceed Instruction Limits:				
Without Gas Holes	1	41,700	Not Available	3.0
	2	40,400	34,500	2.5
With Gas Holes	1	40,500	32,600	3.0
	2	42,660	32,500	5.0

TABLE 3

TENSILE SPECIMEN RESULTS FOR THE A356 ALLOY 9 O'CLOCK STRUT  
PER DRAWING 4012001-381

Specimen	Tensile (psi)	Yield (psi)	Elongation Percent in 2 Inches
Separately Cast Bars Typical	42,700	35,200	5.0
Requested Casting Minimums:			
Caps	33,000	25,000	2.0
Walls	30,000	20,000	2.0
Test Bar Results Taken From Casting:			
1	43,000	32,400	5.0
2	38,600	33,100	5.0
3	41,800	33,500	5.0
4	42,900	33,300	7.0
5	34,000	25,800	3.5
6	36,000	25,800	2.5
7	36,600	31,300	2.5
8	34,200	25,900	2.5

2. All10AT titanium alloy (Ti 5Al-2.5 Sn) was selected for the hot- and cold-side sectors because of experience available from the manufacture of the General Electric J93 engine front frame and the weight requirements. The weight was the major consideration in the design versus formability and cost in the consideration of other materials; the characteristics for this material are as listed below:

	<u>Room Temperature</u>	<u>600°F</u>
Tensile (psi)	125,000	81,000
0.2 Yield (psi)	120,000	66,000
Elongation (percent)	13	13
100-Hour Rupture (psi)		
Bar	Not Available	74,000
Sheet	Not Available	67,000
Modulus of Elasticity (psi)	16.5 x 10 <sup>6</sup>	13.5 x 10 <sup>6</sup>
Charpy V-notch Impact (ft-lb)	17	
Minimum Bend Radius (inch)	4T at 105°F	
Weldability	Good, but requires control	
Repairability	Good, but requires control	
Compressive 0.2 Yield (psi)	120,000	90,000
Bearing Yield	170,000	150,000

3. The materials used in the manufacture of the fiber glass epoxy dome and the requested minimum properties are as listed below:

Laminate - Glass Fabric No. 18 (MIL-F-9084B, Type 8)

Binder - Epoxy Laminating Resin (MIL-9300A, Type 2-1)

Bearing Plate - 321 SS AMS 5510, 0.008 - 0.012 Sheet AMS 4026C  
Aluminum

Insert - 6061 T<sub>4</sub> or T<sub>6</sub> Aluminum

Properties of Composite Laminate Requested:

Density - 0.080 lb/in<sup>3</sup>, maximum

Tensile Modulus of Elasticity - 0.5 x 10<sup>6</sup>, minimum

Transverse Sheet Strength - 12,000 psi, minimum

Flexure Strength - 12,000 psi, minimum

Tensile Strength - 40,000 psi, minimum - measured in the direction of warp and fill on flat panels.

As a check on the manufactured-in stress capabilities of the dome, a flat panel of 0.032 inch thick was made using the same technique used in the manufacture of the dome. This panel was then cut up into tensile specimens for testing to determine tensile strength at three directions to the fabric warp. Other significant test data like resin content density were determined. The results of this testing are tabulated in Table 4.

4. Alloy (17-4 PH) was selected for the manufacture of the hub, 3 o'clock strut, and the end caps because it presents better corrosion resistance, weldability, stability, and strength over other alloys considered, see Figure 1. The design requirement for the minor strut to which the scroll is mounted required material with strengths higher than those available with aluminum alloys and at temperatures (700-800<sup>o</sup>F) too high for aluminum. The material had to be weldable, brazeable, and obtainable in cast form to permit lower manufacturing costs. The materials considered included 410 SS, Marage steel, Hastelloy X, and Chromalloy. Hastelloy X, in spite of its excellent formability and welding characteristics, was eliminated due to its low strength. Chromalloy was eliminated for its lack of corrosion resistance and as such a need for some protective coating. Marage steels were eliminated mainly for the same reason. A contributing factor was that in spite of relatively simple heat treatments, industry had little experience in casting Marage steels. Selection of 17-4 PH over 410 SS was made by virtue of the better corrosion resistance, weldability, castability, and strength.

The heat-treatment condition selected for the 17-4 PH was a 1 hour age at 1025<sup>o</sup>F, which for wrought material guaranteed the following minimum tensile properties:

Ultimate (psi)	155,000
0.2-Percent Yield (psi)	145,000
Percent Elongation (2 in)	12 (bar) 5 (sheet)

TABLE 4

RESULTS OF PHYSICAL TESTS OF FLAT LAMINATE PANEL (0.032 INCH THICK)  
181-150 ERL      2256 RESIN

Property	Condition	Direction	Specimen No.	Tensile (psi)	Average
Tensile Strength	Standard	45° Angle to Warp	1	15,300	
			2	16,670	
			3	12,234	
			4	11,935	
			5	11,375	
Requirements per Drawing: 12,000 psi, minimum					13,502
		Lengthwise	1	50,400	
			2	50,743	
			3	43,140	
Requirements per Drawing: 40,000 psi, minimum					48,090
		Crosswise	1	41,935	
			2	40,645	
					41,290
Tensile Modulus	Standard	Lengthwise	1	2.262 x 10 <sup>6</sup>	
			2	2.586 x 10 <sup>6</sup>	
			3	0.824 x 10 <sup>6</sup>	
Requirements per Drawing: 0.5 - 1.5 x 10 <sup>6</sup>					1.89 x 10 <sup>6</sup>
		Crosswise	1	3.225 x 10 <sup>6</sup>	
			2	2.902 x 10 <sup>6</sup>	
					3.064 x 10 <sup>6</sup>
Specify Gravity Laminate - 1.83; Resin Content - 34.21%;					
Density - 0.063 lb/in <sup>3</sup> ; Requirement per Dwg - 0.080 lb/in <sup>3</sup> , max					

Percent Reduction of Area	45
Hardness	RC 35

See Figure 2 for 17-4 PH characteristics.

The material specification selected for the cast 17-4 PH hub was AMS 5398. The conventional age at 925<sup>o</sup>F was not desirable because of the resulting lower ductility. The specified casting minimum properties when aged for 1 hour at 1025<sup>o</sup>F are as listed:

Ultimate (psi)	155,000
0.2-Percent Yield (psi)	130,000
Percent Elongation (2 in)	6
Percent Reduction of Area	15

The material processing and acceptance standards are covered in an instruction, 4012154-969, Appendix II.

Room temperature tensile properties of specimens taken from the cast hub are tabulated in Tables 5 and 6. Room temperature tensile properties of cast to wrought weld specimens are tabulated in Table 7.

TABLE 5

ROOM TEMPERATURE TENSILE PROPERTIES OF SPECIMENS TAKEN FROM THE LF-2 17-4 PH CAST HUB

Location	A <sup>1*</sup>	B <sup>1</sup>	C <sup>3</sup>	D <sup>2</sup>	E <sup>3</sup>	F <sup>1</sup>	G <sup>1</sup>	H <sup>1</sup>	J <sup>3</sup>	K <sup>2</sup>	L <sup>3</sup>	M <sup>4</sup>	N <sup>4</sup>
Ultimate (ksi)	176	177	178	144.3	176.2	178	174	176.3	177.2	178.8	180	173	174.3
0.2 YS (ksi)	170	169.7	172	143.5	166	173.2	169	170	171	171	173	167	168.3
% Elongation	11	15	14	1	14	9	13	4	9	12	7	13	14
% R of A	49.3	47	40.7	0.8	44	22.6	45	9.3	29.8	37.1	19.2	48.2	47

\*Location in Mold

4012154-969 Minimums

<sup>1</sup> Drag	Ultimate	- 155,000 psi
<sup>2</sup> Cope	0.2 YS (ksi)	- 130,000 psi
<sup>3</sup> Parting Line	% Elongation	- 6%
<sup>4</sup> Unknown	% R of A	- 15%

Casting was homogenized and solutioned per AMS 5398A and aged 1025° for 1 hour. Refer to Appendix II, Instruction 4012154-969, for the specimen location.

TABLE 6

ROOM TEMPERATURE TENSILE PROPERTIES TAKEN FROM A SECOND 17-4 PH CASTING  
AFTER MOLD CHANGES WERE MADE TO IMPROVE THE DUCTILITY FOUND BELOW  
SPECIFICATION LIMITS IN THE FIRST CASTING (SEE TABLE 5)

Location	H	G	K	L	F	E	C	D	D <sup>1</sup>
Ultimate (ksi)	164	163	162.3	164.8	165.3	165.3	163.8	165.1	167
0.2 YS (ksi)	161.8	161.4	161.5	161.4	164.3	164	162.3	163.8	164.3
% Elongation	9.4	12.5	10.9	15.6	+	14.1	14.1	*	10.9
% R of A	30.6	47	34.7	51	54	40	56	*	46

<sup>+</sup>Failed outside gauge marks.

\* Broke in radius of bar.

<sup>1</sup>Retest specimen located within 3/8" of first D specimen and closer to riser.

TABLE 7

## ROOM TEMPERATURE TENSILE DATA OF 17-4 PH CAST TO WROUGHT WELD SPECIMENS

Location	1		2	
	1	2	1	2
Ultimate (ksi)	166	166	170	166
0.2 YS (ksi)	153	159	161	156
0.02 YS (ksi)	113	134	135	126.5
% Elongation (1")	10.1	9.9	9.4	10.6
% R of A	49.0	49.0	42.0	47.0
				43.0

All failures occurred in cast metal side of the weld.

Specimens were aged only after weld, at 1025°F for 1 hour. Weld filler was 17-4 PH wire on a butt weld 1/4" thick prepared and welded from both sides. Tungsten inert arc weld left as welded.

## MOUNTING

The frame is supported in the wing at three mount locations: A and B at each end of the major strut, 12 and 6 o'clock, respectively, and C at the end of the 3 o'clock strut through the use of a support arm, as shown in Figure 3. This arrangement is the same as that used for the X353-5B front frame with the exception of the employment of a support arm to adapt the X353-5A scroll and its restraint requirements. This support arm would be deleted in a flight-type assembly by including it as an integral part of the 3 o'clock strut as shown in the front frame drawing 4012001-386, Figure 4. Mounts A and B are the primary load-carrying members, while mount C, in conjunction with A and B, reacts the loading which tends to torque the main strut. Mount C also carries the major portion of the scroll loading.

## LAYOUT INTENT

The intent of the basic layout of the LF-2 front frame (Figure 5, Assembly Drawing 4012001-379) was to break it up into component parts defined as standing alone, providing an explicit function which when combined would produce a lightweight, low-cost, efficient unit. The frame was divided into eight components, see Figure 6.

1. Major strut, 12 to 6 o'clock - main rotor axial load-carrying member, Figure 7.
2. Minor 9 o'clock strut - maintains cold-side sector roundness and forces cold-side axial movement (helping to maintain seal to rotor clearance), Figure 8.
3. Hub and 3 o'clock strut - mounts the rotor and reacts the torsional producing loading in the main strut by forming a couple with the main strut center; also mounts the support arm to the third frame mount, Figure 4.
4. Dome - forms the inlet airflow path at the hub, Figure 9.
5. Hot-side sector - positions the forward hot gas seal, maintains frame roundness, and positions the inside diameter of the bellmouth. This component is made of two separate parts, Figure 10.
6. Cold-side sector - forms a turbine passing tunnel and mounts the forward hot gas seal and the rear frame, Figure 11.
7. Strut end cap - ties the cold-side and hot-side sectors and main strut into a composite structure; also mounts the scroll ends and frame mounting trunnion, Figure 12.
8. Bracket-dome mounting - mounts the dome center at the hub on the minor 9 o'clock strut side, Figure 13.

The completed frame is shown in Figure 14.

Detailed description of each component follows:

## MAJOR STRUT (12 to 6 O'CLOCK)

### Functions

The functions of the major strut, which runs from the 12 o'clock to the 6 o'clock position, are to provide:

1. Support for the rotor loadings and to transfer them to the installation mounts via the end caps.

(It is to be noted that the loads which would produce torsion in the main strut are taken out by a couple formed in conjunction with the 3 o'clock strut.)

2. Mounting pads for attaching the end of the circular inlet vane.
3. Mounting pads for attaching the dome mounting brackets, thus supporting a portion of the dome loading.

### Description

The definition of the main strut is per drawing 4012001-380, Figure 7. The strut is an aluminum casting with the general shape of that of an archer's bow, being symmetrical to either side of the hub center. The strut's overall length is 73.78 inches, with a chord length at both ends of 3.67 inches which increases toward the hub to 14 inches.

The cross section is that of a hollow airfoil NASA-0018, with a modified chord. The chord is lengthened by the insertion of a constant thickness rectangular section at the maximum thickness of the basic airfoil, moving the leading and trailing edges apart. The center portion of the strut is contoured to straddle the hub while being sandwiched by the hub attachment plates. The trailing edge cap transitions to a rectangular section at the hub, forming an attachment and bearing surface, Figure 15.

Mounting pads are located at 11.79 and 29 inches out from the hub on each side of the strut trailing edge to which the dome attaching bracket and inlet vanes are attached, respectively. The ends of the strut are machined to a rectangular section which sandwiches into the end caps to which they are secured.

### Loading

The strut loading is as shown in Figures 16, 17, 18, and 19.

## Mounting

The strut is attached to the hub by four 0.375 inch diameter rivets, two 3/16-inch-diameter rivets, four 10-32 shear bolts, and eight 1/4-28 bolts, see Figure 22. The attachment of the strut ends to the end caps is by four 1/4-28 bolts and six 10-32 bolts, see Figure 21.

## Design

The general design approach for the major 12 to 6 o'clock strut was to make it a lightweight casting and minimize the cost. It was designed to be manufactured from an A356 aluminum alloy green sand casting. The strut is basically a NASA-0018 hollow airfoil structure with a 5.6 inch chord and a 1.1-inch maximum thickness modified to increase chordal height to meet inertia requirements. This increase in chordal height is accomplished by extending the maximum thickness portion of the airfoil, creating flat side panels on the strut. The requested wall thickness of 0.080 to 0.140 inch required an advance in the present sand casting state-of-the-art wall thickness of 0.180 inch. These thin walls were necessary for a lightweight structure. The leading and trailing edges increase in thickness toward the hub to effect an increase in cross-sectional properties toward the hub, see Figure 15. The stiffness of the strut was of prime importance and was proportioned to limit hub axial deflection to 0.120 inch with the lift loading of 5400 pounds. This limited vertical deflection was required to meet thin wing design and to retain as much of the available axial clearance between the turbine and forward honeycomb hot gas seal as possible for extreme maneuver conditions. The attachment design between the main strut and hub is unique because of the minimum structure required to produce a very efficient load transmitting arrangement, see Figures 22 and 23. The trailing edge center portion of the strut, which sees mainly a compressive load, is machined to straddle the hub while the leading edge cap and a large portion of the center of the strut, which sees tensile loading, remains continuous. The trailing edge cap is usually in a state of compression; therefore, it is widened to form 1.225 square inches of bearing surface to distribute the compressive loading. The trailing edge of the strut assembles with a slight interference fit to the hub, see Figure 15. This slight interference fit assures contact of these surfaces at all times. Four 1/4-28 shear bolts attach each trailing edge cap to the hub. These bolts see very small shear loading because of the prevailing compressive loading and the slight interference assembly. All attaching bolt and rivet holes are match-drilled with the hub to provide best fit for sharing trailing edge load transmission. A step is machined to either side of the strut center web portion so that the web sandwiches with a snug fit into the hub vertical attachment clevis, see Figure 22. This sandwiching of the web center portion stabilizes the strut web. The web is attached by two 10-32 shear bolts,

each strut sharing half of the vertical shear loading. The leading edge cap is sandwiched as above and is attached by four 0.375-inch-diameter shear rivets. These rivets transmit the normal to major strut moment reactions and share in the thrust and the 3 o'clock normal to plane reactions in the hub to the major strut. Two other 3/16 inch-diameter rivets are placed through the hub major strut leading edge attachment clevis to provide stability of the clevis.

A drain-venting hole was located normal to the cross section in both strut halves just above the trailing edge flange to allow the strut to breathe and to prevent the accumulation of water in the strut with change of climatic conditions.

At 12 inches out from the hub, on each side of the strut, the trailing edge was widened to form the dome attachment bracket attachment pad on each strut half. These brackets are attached by two 10-32 through shear bolts in each strut half.

A portion of the strut cross section at 29 inches out from the hub is made solid, providing an inlet vane attachment pad. This pad was recessed into the strut side contour on each side of the strut, attempting to hide the inlet vane flange thickness aerodynamically. Four 1/4-28 through helicoil inserts are placed in the pad and are staggered in line to allow for minimum bolt thread engagement. The cross section 26 inches out was also made solid, except for an internal trailing edge drain-vent hole having the same purpose as mentioned before, to provide an attachment area for the closure door if required for test purposes; otherwise it served no purpose except to act as a wall stiffener.

The outer end of the strut was made solid and machined to a rectangular cross section, forming the strut end attachment flange. This flange is sandwiched in the strut end caps and attached by four primary 1/4-28 shear bolts and by four 1/4-28 and four 10-32 shear-tensile bolts. All but two of the primary bolts serve a dual purpose by attaching the cold- and hot-side sectors to the end cap, see Figure 21.

### Stresses

The stresses in the major strut are low due to the deflection being of major importance. The use of a three-to-one shear buckling factor in the wall design permitted the strut to be designed by simple beam theory. The maximum shear in the walls is only 3400 psi at 32 inches from the hub and 2060 psi at 7 inches from the hub. The strut leading edge cap, being angled some 15 degrees upward toward the hub, carries approximately 26 percent of the vertical shear loading. The maximum tensile stress occurs when the 2 rad/sec gyro is reacted by the 3 o'clock strut producing the worst loading, see Figures 16 and 18. This stress is

12,500-psi tensile on the leading edge at the center of the strut and decreases to 4100-psi tensile at 27 inches out from the hub. The trailing edge cap is in a state of compression for all practical purposes at all times even though a small tensile load can exist at maximum loading condition, as can be seen from the bending moment diagram of Figures 17 and 19. The trailing edge cap's worst compressive stress occurs when the exit louvers are vectored to 40 degrees closed and with the 2 rad/sec gyro reacted by the 3 o'clock strut. This stress is 13,500 psi compressive. The bearing stress of the trailing edge cap against the hub is only 17,100 psi, 43 percent of the 40,000 psi allowable. At the leading edge attachment to the hub the worst loaded rivet hole inner surface has a bearing stress of 24,000 psi, which is only 60 percent of the allowable. When gyro is not acting, all stresses are cut in half, making for a very reliable component.

### NINE O'CLOCK STRUT

#### Functions

The functions of the 9 o'clock strut are to provide:

1. Support for the cold-side bellmouth structure to help maintain frame roundness and to force the bellmouth to move axially with hub rotation, helping to maintain forward air seal to rotor carrier lip seal axial clearance.
2. Mounting pads for attaching the end of the circular inlet vane.
3. A mounting boss for attachment of the closure door latch attachment of the closure door latch trunnion.
4. Support for the closure door in the emergency of a hydraulic failure.
5. A mounting pad for attaching the dome mounting brackets, thus supporting a portion of the dome loading.

#### Description

The definition is per drawing 4012001-381G5, see Figure 8. The strut is an aluminum casting with the general shape of a NASA-0018 airfoil which is modified to lengthen its chord. This lengthening is accomplished by the insertion of a constant-thickness rectangular section having the maximum thickness of that of the basic airfoil and being inserted at the maximum thickness location, moving the leading and trailing edges apart. The strut is 31.72 inches in length and increases in effective chord length toward the hub while the trailing edge remains

parallel to the rotor plane. The cross section changes from an airfoil to an I-beam under the dome and to a rectangular plate at the cold-side sector. Attachment pads are provided at each end for securing the front frame assembly. Pads are provided at a radius of 29 inches and 11.75 inches on the strut sides for mounting the circular portion of the inlet vane end and the dome mounting brackets, respectively. A boss is provided at a radius of 26.2 inches on the strut sides to accommodate the attachment of the closure door latch trunnion.

### Mounting

The strut ends are bolted to the hub and cold-side sector. At the hub, the leading and trailing edge is bayoneted by the hub structure and each is attached using four 10-32 axial directed bolts, two on each side of the strut center plane. The web is attached to the hub by using three 10-32 bolts directed normal to the strut center plane, see Figure 21. At the cold-side sector the strut end is sandwiched between two back-to-back reinforced cold-side sector gussets and attaching three 1/4-28 titanium bolts, see Figure 24.

### Design

The general design approach of the 9 o'clock strut was for lightweight and low cost structure. The strut is a hollow airfoil shaped A356 aluminum cast beam using a modified NASA-16-018 airfoil. The leading and trailing edge caps are made of constant height for the airfoil length of the strut for simplicity of manufacturing. An increase in cross-sectional properties is effected by increasing the chordal length by extending the maximum thickness portion of the airfoil, see Figure 25 for cross-sectional properties. This extension causes a flat in the side of airfoil, increasing in height toward the hub. The strut is made hollow to minimize weight. The wall thickness of 0.080-0.140 inch was requested, knowing that the state of the art is closer to 0.180 inch for this type of casting. The attachment of the strut to the hub is shown in Figure 22. To provide an efficient joint, the strut leading and trailing edge caps were gradually increased in width, developing into a rectangular flanged I-beam structure. These flanges are grooved to effect a sandwiching joint with the flange on the hub, eliminating induced joint bending stresses in either structure and the attaching hardware. To provide an ultra safe hub area design, four shear bolts are used to attach each cap even though two would be more than sufficient to carry the cap loading of 950 pounds. The strut shear web is also sandwiched in a vertical clevis on the side of the hub and attached using three shear bolts. This attachment is also free of induced bending stresses. Close tolerance match-drilled holes were employed in attaching the strut to the hub.

The trailing edge is widened on each side at 12 inches out from the hub to provide material for a pad to attach the dome attaching brackets. Two match-drilled 10-32 shear bolt holes are drilled at assembly to assure bracket and dome alignment.

### Stress

The stresses in the 9 o'clock strut are low because this strut's purpose is secondary in nature, not a branch of the main load-carrying components. The main purpose of the strut is to provide roundness of the frame and force the cold-side sector to follow the hub rotation. These loads required to accomplish its purpose are small, thus low stresses, see Figures 25 and 26. The maximum bending stress, occurring with a 5400 pound hub lift load and a combined 2-rad/sec gyro load reacted by the 3 o'clock, is only 4300 psi using a load factor of 3. This stress exists in both the leading and trailing edges because the centroid of the cross section is equally spaced between the leading and trailing edge caps. The maximum shear stress for the same loading is less than 582 psi. There are higher bending and shear stresses, being 14,800 psi and 5110 psi, respectively, which can exist only when the closure doors are closed and the hydraulic systems fail. This higher bending occurs at 26.2 inches out from the hub at the closure door latching boss location. At the hub cap attachment locations, the bearing stresses for the bolt holes are only 4500 psi each, which is ultraconservative. These low stresses make for a reliable hub assembly, the hub assembly being the backbone of the frame.

### HUB AND 3 O'CLOCK STRUT

The hub and 3 o'clock strut is an integral component because of weight and space considerations. The chord was limited in length in order to maintain the leading edge cap 1/2 inch below the wing upper contour. This short chord causes large loads to be interchanged between the hub and strut. To achieve an efficient joint structure, continuous centroids were maintained between the strut caps and the hub flanges by welding the parts together, forming the integral component. A discussion of the hub and then of the strut follows:

#### Hub Functions

The functions of the hub are to provide:

1. A mounting shaft for the rotor.
2. Flanges and bearing surfaces for attaching the 9 o'clock strut and the major strut.

3. Load-carrying structure to transfer the rotor, the 3 o'clock, and the 9 o'clock loadings to the major strut.
4. A mounting boss for attaching the speed sensing housing.
5. Mounting pads for attaching the center portion of the dome.

#### Description

The definition is per drawing 4012001-386, see Figure 4. The hub is primarily a nonrotating shaft with integral flanges, bearing surfaces, clevises, and bosses for attachment of the adjoining components, see Figures 27 and 28. The shaft portion is 11.35 inches long and can be divided into two parts, the lower or protruding portion which contains the two bearing mounting diameters and the upper portion which has the integral attachment flanges and the joining surfaces for connecting the struts. The shaft is hollow and increases in diameter from the lower ball bearing location toward the roller bearing location where a maximum diameter of 4.775 inches is reached. This diameter is then maintained for the remainder of the shaft.

Located at the extreme lower end of the shaft is a ball bearing inner race retaining flange which contains eight holes and shank nuts. The upper end of the ball bearing inner race butts against a thrust shoulder which reacts the rotor lift. A roller bearing inner race locating shoulder is located 5.293 inches above the thrust shoulder. The integral attachment structure for the main strut is positioned symmetrically about a 3 and 9 o'clock vertical plane. Just above the roller bearing locating shoulder, two in-plane flanges with vertical and in-plane bearing surfaces protrude in the 12 and 6 o'clock direction to join the major strut trailing edge caps. Then above these in-plane flanges, a pair of continuous flanges protrude from the top and sides of the shaft to form a clevis which attaches to the web and leading edge cap of the major strut.

The integral attachment structure for the 9 o'clock strut consists of two identical in-plane flanges and two vertical flanges located 90 degrees from the major strut, see Figure 28. The in-plane flanges are positioned just above the roller bearing locating shoulder and just below the upper end of the shaft. The trailing and leading edge caps of the strut are attached to these flanges. The vertical flanges form a clevis to which the web of the strut is sandwiched and attached.

The integral attachment structure for the 3 o'clock strut consists of two identical in-plane flanges and two vertical flanges located 90 degrees from the main strut and 180 degrees from the 9 o'clock strut. The in-plane flanges are thicker than those for the 9 o'clock strut.

They are located in line with the main strut attachment flange and at the very end of the shaft. The 3 o'clock strut leading and trailing edge caps are welded to these flanges. The vertical flanges are a raised portion on the shaft in which a step is machined for locating the strut web skins. The web skins are butt-fillet welded to these flanges.

An in-plane flange, located in the 6 o'clock to 9 o'clock quadrant, protrudes from the trailing edge cap attachment flange to provide a bore for attaching the speed sensing housing, see Figure 24.

A core hole is located at approximately midheight in the upper shaft wall centered in the 6 o'clock side main strut web attachment clevis, see Figure 28. This core hole provides a means of routing instrumentation leads from the interior of the shaft.

Four dome mounting brackets with pads and welded-on floating nut plates are located at the outer periphery of the upper end of the shaft, see Figure 22. These flanges are symmetrical about the 6 to 12 o'clock and 3 to 9 o'clock vertical planes.

#### Mounting

The hub and 3 o'clock strut can be considered as the primary components to which the strut structure of the frame attaches. For the definition of the specific hardware used in the individual strut attachments, see the specific component mounting discussion.

#### Loading

The tabulated hub and minor strut loadings are shown in Figure 29.

#### Design

The general approach was a simple reliable lightweight low-cost structure. To achieve this, the hub was designed around a 17-4 PH Shaw process casting utilizing the same 3 o'clock strut structure and manufacturing tooling used in the XV-5A front frames. Because of the large diameter of the rotor and the necessity for fitting the fans into thin wings, the axial excursions of the rotor tip was a prime consideration in the shaft design. The shaft wall thickness is positioned to limit the rotor forward air seal lip axial deflection to 0.090 inch when loaded in bending to 200,000 pound-inches, see Figure 29 for shaft properties.

The actual design of the hub is quite unique in the way the shaft is integrated with the attachment flanges to yield a lightweight efficient structure. The design puts high strength and high modulus material in

the highly loaded areas where the shaft loads are transferred to the strut structure. This integral flange to shaft design simplified the strut attachment design and eliminated the conventional shaft in bore assembly which requires doubling up on the load-carrying and transmitting structures. The flanges protruding normal from the shaft reinforce the shaft cross-sectional properties and keep radial deflection and in-plane bending stresses due to strut cap bearing loading to a minimum.

### Stresses

The stresses that exist in the hub are within the 130,000 psi minimum 0.2 percent yield with the worst load condition on the shaft, see Figure 29. The magnitude of the gyro moment was increased by a factor of 1.2 at the 115 percent fan speed setting. Maximum bending stresses of 33,600 psi and the shear stress of 68,200 psi exist at the ball bearing location and at the upper 3 o'clock strut flange location, respectively. A bending stress of 56,000 psi exist just above the roller bearing location. The compressive stress associated with the 10,600-pound load is 2800 psi in this area. An additional shear stress, associated with the 2000-pound partial admission load, adds a further 1000 psi at the maximum bending stress location. Combining the stresses in the portion of the shaft which mounts the rotor yields a 57,500-psi compressive stress and a 56,000-psi tensile stress in the shaft. The maximum stress exists in the upper flanges, 3 inches below the rivets which attach the major strut leading edge cap. This stress is 110,000 psi in beam bending, and when combined with the associate shear stress results in an equivalent stress of 114,700 psi. The bearing stress in the rivet holes, which attach the strut leading edge, is 52,000 psi, compared with an allowable stress of 200,000 psi. A bending stress of 84,000 psi exists in the weld attachment of the 3 o'clock strut to the hub, see Figure 28. From actual weld test specimen tensile results, a minimum 0.2 percent yield of 149,000 psi, an elongation of 9.9 percent, and a reduction of area cross section of 42 percent was achieved.

The fundamental frequency of the shaft, treating it as a hollow cantilevered cylindrical unloaded beam, was calculated to be 18,167 cycles per second. This is far in excess of the fan exciting frequencies up to 115 percent speed. This high value of the fundamental frequency makes it almost impossible for the shaft to be excited.

To summarize the stress picture in the hub, it can be seen that with a load factor of 1.2 applied to the gyro maneuver loading all existing stresses are well below the allowable 130,000 psi, 0.2 percent yield, producing a reliable component.

### 3 o'clock Strut Functions

The functions of the 3 o'clock strut are to:

1. Provide a support structure to react torsional producing loading in the main strut.
2. Provide mounting bosses for attachment of a closure door latch trunnion and a through attachment of the two hot-side sectors.
3. Provide support for the closure door loading in the emergency of a hydraulic failure.
4. Provide mounting brackets and bosses for attaching the dome, thus supporting a portion of the dome loading.
5. Provide mounting pads for attaching the end of the circular inlet vane.
6. Maintain roundness of the frame.
7. Provide mounting pad attachment for the support arm.

Note: The support arm is an extension of the strut which provides the scroll center mounting boss and the third frame mounting point. The support arm would have been an integral part of the strut if it had not been for the required adaption of both the original single inlet scroll and the new proposed power transfer scroll.

### Description

The definition is per drawing 4012001-386, see Figure 4. The inner end of the 3 o'clock strut was welded to the hub to make an integral unit. The general shape of the strut is a hollow NASA-16-018 airfoil with a constant chord of 5.6 inches and a maximum thickness of 1.00 inch. The leading and trailing edges are parallel to the plane of the rotor. Both the leading and trailing edge caps widen in the dome area to a width of the shaft upper diameter. The outer end of the strut shortens in chordal length and transitions to a rectangular cross section and terminates in a six-bolt hole vertical flange for attaching the support arm. The support arm is a separate attaching part required to adapt either the original X353-5A single inlet scroll or an X353-5B double inlet scroll.

Four dome mounting brackets with pads, two on each side of the strut, are located symmetrically about the 3 to 9 o'clock vertical plane at the strut leading edge. Including the two pads located on the 3 o'clock

side of the shaft, six mounting brackets with pads are provided for attaching the dome on the 3 o'clock side, see Figure 23. A single floating nut plate assembly is welded to the underside of each pad.

Two, two-hole vertical dome mounting brackets with integral attached floating nut plate assemblies are located 12.00 inches out from the plane of the 6 and 12 o'clock strut, one on each side of the trailing edge cap, see Figure 23.

Two closure door latch trunnion bosses are located symmetrically about the 3 to 9 o'clock vertical plane 26.2 inches from the hub centerline. Further out at 29 inches from the hub, two symmetrical inlet vane end attachment pads are recessed in each side of the strut. Two bolt holes with assembled shank nuts are located in the vane pad. Four bosses penetrate through the strut 32.84 inches from the hub. These bosses form the hot-side sector end attachment pads on both sides of the strut at the 3 o'clock location, see Figures 15 and 23.

### Mounting

The 3 o'clock strut is a major component part of the frame and is permanently attached to the hub by fusion welding. All other connecting attachments are made to the strut by bolting, see the hot-side sector and dome mounting section.

### Loading

The maximum loading experienced by the 3 o'clock strut is the gyro moment induced by a pitching maneuver, see Figure 30. This 200,000-pound-inch moment has a 1.2 factor applied at a fan speed of 115 percent.

### Design

The design of the 3 o'clock strut is identical to that of the X353-5B front frame strut except for the strut ends and the material. The strut is a hollow airfoil fabricated beam manufactured from wrought 17-4 PH material. It consists of solid leading and trailing edge caps with 0.030 inch thick skins for webs. The caps are machined from bar stock. To provide vertical stiffness and to react the strut bending loads, the cross-sectional area of the caps increases toward the hub, effecting an increase in sectional properties. To stabilize the 0.030-inch skins, "U" shaped bulkheads are spaced between the caps. These bulkheads are welded to the caps, forming a ladder-type structure. Brazing of the skins to the bulkhead flanges was necessary due to the inaccessibility of other types of attachments. Coast metal 52 alloy is used as the brazing material, Appendix II, Instruction 4012154-969.

Because of problems encountered in attempting to braze the skins to the caps in the X353-5B front frame, fusion fillet-butt welding was specified for the LF-2. The cap cross-sectional areas were proportioned to provide continuous cap centroids to eliminate induced secondary loads. The composite strut cross-sectional centroid was designed to be equal in distance from both caps to accommodate both the pitch up or down maneuver producing gyro moments in the strut. The closure door bosses were sandwiched between and attached to two bulkheads to efficiently distribute closure door latch loading to the skins and the caps without induced load path discontinuities. The inlet vane pads were recessed into the skin in an attempt to hide the vane flanges aerodynamically. Because of limited strut thickness and to provide internal bolt room, the bolt hole patterns in each pad were staggered. The pads in each skin were connected through the strut using a 0.04-inch-thick rectangular box construction brazed to each skin. This through connection lets one inlet vane quadrant react against the one in the adjacent quadrant, reducing induced loading in the strut skins.

The cross section at the end of the strut was made rectangular, equal to the maximum width of the strut, to produce a smooth decrease in properties. The caps were made of constant thickness so they could be machined from plate material, reducing cost. To increase further the stiffness of this end of the strut, a 1/8-inch-thick center web was added, running from the airfoil shaped caps to the vertical end flange. This web was fusion fillet welded to the cap and end flange. To redistribute the dog-leg loads of the change in direction of the cap centroids, a bulkhead was positioned at the end of the airfoil section attaching the caps to the skins and the 1/8-inch center web.

To provide for attaching the hot-side sector to the strut and to each other, three through bosses were placed horizontally through the skins, center web, and bulkhead flanges. These bosses were fusion welded to all three pieces. A fourth boss was required to be positioned on the outside of the bottom cap because of space crowding, see Figure 15. The design of this strut is considered good, yielding a stiff, efficient lightweight component for the space available.

### Stress

The strut is designed using a three to one critical shear buckling factor to assure the strut to follow simple beam theory. Stiffness was a prime consideration at all times; see Figure 31 for the cross-sectional properties. The maximum stress, 85,000 psi bending, occurred at the fusion-butt-welded joint of the caps to the hub flange. For actual weld test specimen results, see Table 7. These achieved results of 0.2 percent yield, 149,000 psi, and 9.9 percent elongation; reduction of area of 42 percent made this joint feasible. The skin shear associated with this bending is 3800 psi. At 31.7 inches out from

the hub, a bending stress of 27,000 psi exists which increases to 51,000 psi at the end of the airfoil section. Associated with these bending stresses are the shear stresses of 9100 psi and 7600 psi, respectively. The outer rectangular end of the strut operating temperature is 750°F and with these existing low stresses for the maximum possible loading provides a very reliable main support structure.

## DOME

### Function

The function of the dome is to provide a flow surface over the hull region of the front frame and rotor.

### Description

The definition is per drawing 4012001-383, Figure 9. The shape is an inverted bowl with a flat bottom. The height is 5.82 inches and the diameter is 25 inches at the open end. It is made in halves and each half is separated by the major strut. Strut passage openings are provided in each half to allow the halves to straddle the minor struts. It is constructed from a glass-cloth epoxy resin lay-up with aluminum inserts and a stainless steel bearing plate, see Figures 9, 32, and 33.

### Loading

The actual pressure distribution existing over the dome is shown in Figure 34. For design, it was assumed that a 1.02-psi pressure differential existed over the inner dome surface, which, when distributed to the rib structure, loaded the dome quarter, as shown in Figure 35. It was assumed that the loading on the skin, acting as a plate and not as a membrane, was equally proportioned to the adjacent ribbing.

### Mounting

Each dome half is secured at the hub by two radial bolts on each side of each strut (four places total), and by six axial screws in a truncated pattern in the center flat portion to six pads located symmetrically with the minor struts, see Figure 34. The mount loads for design are shown in Figure 36.

### Design

The general approach was to provide a lightweight reliable dome which would give trouble-free operation. The logical choices of material were magnesium or aluminum sheet. These were rejected because of previous problems with poor weld integrity and the design practice of

no rivets forward of the rotor. The next best material when considering weight, part, and tooling cost was a fiber glass laminate. The density of a six-part glass to four-part resin laminate was quoted at 0.080 pound/inch<sup>3</sup>, making it possible to match if not better the weight of a comparable aluminum constructed dome. The construction employed was an outer skin attached to a rib network load-carrying structure with aluminum inserts and bolt and mount surface bearing plates to distribute the mounting loads. A glass-to-resin ratio of six to four was requested, assuring the density and high stress capability. The outer surface is 0.030 inch thick, consisting of three layers of cloth, except for the areas adjacent to the four struts which is 0.080 inch thick. The geometry of the ribs was obtained by the use of polyurethane foam forms. The joints between the ribs, outer skin, and adjacent ribs employ the delta corner construction. The delta was formed by prewrapping the rib foam form with a single layer of cloth prior to attaching to the outer skin or adjacent ribs, see Figure 37. This joint construction is typical at all surface intersections giving support to the resin rich corners, thus producing a sounder structure.

The polyurethane foam form's only purpose was to position the cloth laminates during the lay-up and the curing cycle and was not considered to add to the structural strength.

The aluminum inserts are used at each end of the bottom circumferential rib where each dome quarter is attached to the struts. Their purpose is to provide bolt bearing surfaces and to funnel the dome loads from the outer skin and ribs to the mounting bolts. It is prewrapped with layers of cloth to effect the "delta" joint reinforcing and securing the insert in the structure, see Figure 38.

The bearing plates, used at the mount locations, provide a flat surface and eliminate machining. These plates are used in three typical locations: one is at the inner attachment surface on each side of the struts where a 0.015-inch-thick rectangular aluminum sheet forms the mounting surface; the second is on the underside of the dome at each axial screw location where a 0.010-inch-thick aluminum washer forms the mounting surface; the third is a truncated 0.010-inch-thick steel plate with six formed dimples providing a tight bearing surface for the 100 degree flat heat axial screws. It also funnels dome loading to each axial mounting screw.

### Instrumentation

The dome structure was modified to add static pressure probe instrumentation. Five static probe reinforced areas were added to each dome half as shown in Figure 33. These reinforced areas are drilled through for the purpose of supporting cemented-in 1/16-inch-diameter instrumentation tubing.

## Stresses

The calculated stresses in the dome are small and result in large margins of safety. These margins are: for the interlaminar bond shear, 6.7 minimum; for tensile, 3.38 minimum; and for cross shear, 8.5 minimum. The high safety margins should offset manufacturing inconsistencies and careless handling damage to give a most reliable part. The maximum stresses and their locations are shown in Figure 39. The stresses were calculated using the "Digital Computer Program for Static and Dynamic Analysis of General Structures, (Mass) Program" to determine the rib structure member loads. The general stress formulas used were:

$$\text{Bending } (\sigma_B) = \frac{Mc}{I}$$

M = Bending moment - pound-inches

c = Distance from section axis to point of stress - inches

I = Moment of inertia - inches<sup>4</sup>

$$\text{Torsional Shear } (T_T) = \frac{T}{2A_i t}$$

T = Torque - pound-inches

A<sub>i</sub> = Enclosed area of cross section - inches<sup>2</sup>

t = Skin thickness - inches

$$\text{Normal Loading } (\sigma_N) = \frac{P}{A}$$

P = Normal load to cross section - pounds

Average

A = Cross-sectional area of rib skins - inches<sup>2</sup>

$$\text{Cross Shear } (T_c) = \frac{P}{2ht}$$

h = Cross-sectional height - inches

Average

$$\text{Bond Shear } (T_B) = \frac{(\Sigma\sigma_B)(A_o)}{w}$$

A<sub>o</sub> = Skin area to one side of bond - inches<sup>2</sup>

Σσ<sub>B</sub> = Summation of the average bending stress in the skin

w = The cross sectional width of bond (laminar overlap) - inches

Margin of Safety (MS) =

$$\frac{\text{Stresses (results of test)} - 1}{\text{Stress in Part}}$$

2000 psi was used for bond shear.

To calculate the margin of safety for the bending and cross shear, actual minimum test specimen results were used. The test results produced an ultimate of 11,375 psi for specimens pulled at 45 degrees to the cloth warp.

#### HOT-SIDE SECTORS

##### Function

The function of the hot-side sector is to provide a flange for mounting the forward air seals, to maintain concentricity of the seals with the rotor, to react a small portion of the scroll in-plane loading, and to provide a mechanical slip lip seal for the bellmouth inside diameter.

##### Description

The definition is per drawing 4012001-385, Figure 10. The hot side sector consists of two 90-degree quadrants laying between the 12 to 3 o'clock and the 3 to 6 o'clock locations. These two quadrants are identical except for the flange end. The ends differ in their mating with the cold-side-sector flange ends at the 12 and 6 o'clock locations and also at the 3 o'clock location where they mate with each other, Figure 15.

The sectors were made using wrought Al10AT titanium material. It consists of a tube, equally spaced gussets, end attachment flanges, and a circumferential hot gas attachment flange. The tube is approximately 65 inches in diameter and has a 0.030-inch-thick wall rectangular cross section, Figure 40. The gussets are 0.015 inch thick and equally spaced along the tube, supporting the forward hot gas attachment flange. This flange is "L" shaped with a tapered upper inside diameter leg to mate with the bellmouth. The ends of the sector are capped off with vertical flanges for mating with the attachment pads located on the sides of the end caps and the 3 o'clock strut.

## Mounting

The sectors are attached to the sides of the end caps and the 3 o'clock strut using 10-32 titanium through bolts, and steel self-locking nuts. Four bolts, which serve a dual function by also attaching the sector on the opposite side of the strut, are used at each attachment pad location (Figures 15, 23, and 40).

## Design

In general, the design was a lightweight structure which would position and maintain the concentricity of the hot gas seal with the rotor turbine hot gas seal lip. The hot-side sector was divided up into two quarter components because of the lack of space between the scroll and front frame at the 3 o'clock strut location. Other reasons for this division are that small parts present less potential manufacturing difficulties and are easier to handle. The cost of manufacturing and assembling two smaller parts versus one larger, cumbersome part was felt to be about equal.

The material used because of its low density and good properties was ALLOAT titanium. This material is discussed in the Material section.

The construction, using tubes, gussets, and flanges, provided a lightweight design meeting the design requirements of keeping the hot gas seal in position and providing a seal lip for the bellmouth inside diameter.

A tube was used for the main structure because it provided maximum torsional stiffness for the space available.

The attachment flanges at the ends of the tube are similar except for the hole and reinforcing gusset pattern, Figure 41.

A combination 0.060-inch-thick doubler and right angle tube to flange stiffener with corner supports was used at the ends of the tubes to reduce the bending stresses and distribute the attachment flange and gusset loads, see Figures 23 and 40. Right angle gussets were used between the tube and the end attachment flange for the purpose of stiffening the flange, thus reducing flange deflection and forcing the sector to load in bending. The forward hot gas seal flange was attached to the end attachment flanges and to the tube by equally spaced gussets to position it axially and radially and to give it torsional restraint. The bellmouth seal lip of the seal flange was tapered and recessed for ease of assembly and to eliminate a step in the flowpath when the bellmouth is positioned at installation.

Shank nuts were used in the forward hot gas seal flange because of

inaccessibility of these nut locations at assembly. A spacer with a chordal sector removed was used under each shank nut, so as to clear the radius between the two legs of the flange. These spacers were required because of the narrow flange design dictated by lightweight requirements and space limitation between the flange and the scroll. A drain-vent hole was located in the lower portion of the tube to prevent the accumulation of water with changes in climatic conditions. The hole area is reinforced with a doubler washer.

All fusion welds of the tube to the end flange and the doubler to the end flange were 100 percent material thickness penetrated. This 100 percent penetration provides more efficient, confident weld joints.

The tube cross-sectional properties are tabulated below:

- Maximum Moment of Inertia	0.209 inch <sup>4</sup>
- Minimum Moment of Inertia	0.016 inch <sup>4</sup>
- Cross-Sectional Area	0.15 inch <sup>2</sup>
- Enclosed Area of Tube	1.242 inches <sup>2</sup>
- Torsional Constant	0.0195 inch <sup>4</sup>
- Tube Wall Thickness	0.030 inch

### Stress

The only loading in the hot sectors is induced by virtue of being attached to other components, the support of the bellmouth loads no longer being a consideration. Temperature also induces a bending stress which is quite low for the operating temperature of 400<sup>o</sup>F for the tube. This stress is only 20,000 psi in bending. The induced bending during normal fan operation without gyro is 14,000 psi, and when the gyro loading of 200,000 pound-inches due to pitch is acting, this stress increases to 19,000 psi; the worst combined stress is 39,400 psi.

These low stresses are the result of a stiff main strut and hub structure, a low material modulus of elasticity, and a low thermal expansion. All of the calculated stresses are far below the 0.2 percent yield, resulting in a reliable component.

## COLD-SIDE SECTORS (6 to 12 O'CLOCK)

### Function

The functions of the cold-side sector are to:

1. Provide a mounting flange for attaching the rear frame.
2. Provide a mounting flange for attaching the forward hot gas seals.
3. Provide a cold-side passing tunnel for the rotor turbine when out of the active arc of the scroll.
4. Provide attachment holes for stabilizing the center radial portion of the front frame cold-side tunnel insulation blanket.
5. Provide the necessary structure to maintain roundness and support the attached components.
6. Provide two flanges on each end for attaching the scroll end seals.

### Description

The definition of the cold-side sector is per drawing 4012001-384, Figure 11. The sector is approximately 75.26 inches in diameter and 180 degrees in circumference. It consists of a main structural circumferential tube with vertical end attachment flanges which attach to the 12 and 6 o'clock strut end caps. Twenty-four 0.015-inch-thick radial impaled gussets are spaced along the tube supporting the forward hot gas and rear frame attachment flanges, Figure 24. Thirteen "L" shaped shear panels attach to both flanges and the lower leg of radial gussets to form the cold-side turbine passing tunnel, Figures 15 and 42. Gaps between these panels are covered with omegas. At each end of the tunnel located to the right side of the 12 to 6 o'clock strut are the scroll end seal attachment flanges. This flange runs radially from the forward hot gas seal attachment flange to the rear frame attachment flange. Each flange has two bolt holes with riveted-on floating lock nuts because of inaccessibility at assembly. Twenty-four staggered, washer reinforced bolt holes are located in the shear panels for attaching the center portion of the front frame insulation blanket, Figure 15. At the 9 o'clock location of the sector, two of the support gussets are positioned back-to-back forming a clevis to sandwich the end of the 9 o'clock strut for attachment. These gussets, which have three lined through attachment holes, are reinforced with a 0.060-inch plate. A washer reinforced drain hole is located in the bottom side of the tube. The rear frame flange is "L" shaped with equally spaced bolt holes with an additional two bolt holes at each end cap location for

attaching the rear frame through to the end caps. The forward hot gas seal flange is "L" shaped, having 24 equally spaced bolt holes in the horizontal leg with a radial recessed tapered upper leg for locating the bellmouth inner lip diameter, see Figure 42.

### Loading

The loading in the cold-side section is induced by frame distortion and by that portion of the rear frame vertical load which is supported by the cold-side sector. One-eighth of the rear frame and exit louver vertical loading is assumed to be carried by the cold-side structure. This loading is approximately 34 pounds' pull applied to each of the 24 gussets. If the exit louvers are set at zero degrees, opening the rear frame puts a 10-pound compressive loading in each gusset. The 34-pound or 8 pound load will never be seen and the likelihood of actually experiencing half that much would be remote. This is so, because the rear frame effective cross-sectional properties are much larger than those of the front frame cold-side sector. More than likely, the bulk of the rear frame loading will be transmitted directly at the 12 and 6 o'clock strut end cap locations.

### Mounting

The cold-side sector is attached to the 12 and 6 o'clock strut end caps by two 1/4-28 bolts and by four 10-32 bolts, Figure 21. The 9 o'clock strut end is attached at the 9 o'clock location by three 1/4-28 bolts, Figure 24.

### Design

The general design approach was to provide a lightweight structure. Wrought titanium Al10AT alloy was used for this fabrication because of its low density and good strength capabilities, see Material section for discussion of material used. It is also weld repairable and does not require subsequent heat treat. The elongation and ductility of this material help to reduce the fabrication producing stresses. The general appearance of this sector is very similar to that of the X353-5B cold-side sector, except for the 2.5-inch-diameter tube which replaces the bellmouth skins. The tube was used because it provided the lightest weight and best all-around structure for reacting the induced loads. The tube walls were originally sized to be 0.030 inch, but because of spinning difficulties the thickness was increased to 0.060 inch. The tube was designed to be the main load-carrying structure to which the integral components of the sector attach. The sector was made continuous, and not divided into quadrants like the hot side, because of more than adequate space around the end of the 9 o'clock strut. To break this sector at the 9 o'clock location would add cost and weight to

the structure. The weight would come about by doubling up on the end flanges and doublers to effect the required added end attachments. Vertical flanges were placed at each end of the tube for attaching the tube to the strut end caps. These vertical flanges were reinforced to the tube by right angle gussets. Doublers were placed around the tube ends to distribute and reduce the tube end stresses. To attach the seal and rear frame flanges, a closed flanged gusset of 0.015 inch thickness was used. This gusset was made with an eyeletted center so as to circumscribe the tube. The eyelet flange is skip-fusion fillet welded to the tube circumference. These gussets were placed approximately on a 7.5-degree spacing except in those areas which interfered with the bolt holes in the flanges. The bolt holes in the flanges could not be moved because of the requirement to assemble with the existing X353-5A rear frame. Both the seal and rear frame flange are positioned by the gussets to which they are fusion welded. The rotor passing tunnel structure and method of attachment to the flanges are made identical to those of the X353-5B except for the installation attachment holes for the front frame insulation blanket. These holes were made to match the existing studs in the blanket. The forward seal flange ends were stepped for alignment and were made to lap the hot-side sector flanges, providing a continuous surface for seal attachment. The rear frame flange was made to extend beneath the end cap flange for the purpose of effecting a continuous surface for attaching the rear frame.

A vent-drain hole was located in the lowermost part of the tube to prevent the accumulation of water in the tube because of changes in climatic conditions. The vent hole was reinforced using a fusion welded-on washer doubler.

### Stresses

The cross-sectional properties of the cold side sector tube are as follows:

- Maximum Moment of Inertia	0.3 inch <sup>4</sup>
- Cross-Sectional Area	0.462 inch <sup>2</sup>
- Enclosed Area of Tube	4.785 inches <sup>2</sup>
- Wall Thickness of Tube	0.060 inch
- Torsional Constant	0.7 inch <sup>4</sup>
- Tube Diameter	2.5 inches

The stresses calculated for the cold-side sector assume that the tube carries all the loads.

The material properties are given in the Material section.

The maximum stresses associated with the worst loading of 200,000 pounds/ inch pitching gyro, exit louver vectored to 40 degrees, full lift, and one "g" up loading are as follows:

- Maximum In-Plane Bending	13,000 psi
- Maximum Torsion	6,900 psi
- Maximum Normal Shear	1,400 psi
- Maximum In-Plane Shear	2,100 psi
- Maximum Compression	150 psi

All these stresses occur at the outer edge of the tube end doubler. These calculated stresses are quite low as compared to the allowable 0.2 percent yield of 102,000 psi. It should be remembered that frame stiffness is of primary importance.

The gusset on the flange sees a maximum of 10 pounds' compressive loading and 34 pounds' pull resulting in a bending stress of 2000 psi compression and 6800 psi tensile, respectively. Local buckling of this flange is not of importance because of the 15,000-psi allowable compressive stress as compared to the 2000-psi actual compressive stress. It is concluded that the operating stresses of the cold-side sector are very low, providing a competent component.

### STRUT END CAPS

#### Function

The functions of the strut end caps are to:

1. Provide a common bolted tie joining the main strut ends to the cold-side and hot-side sectors and forming a continuous structure at these locations.
2. Provide a fan mounting trunnion attachment pad for securing the fan assembly in the wing.
3. Provide scroll end clevis attachment pad for securing the scroll

ends.

4. Provide a rear frame attachment flange to react the rear frame stator torque, exit louver loading, and "g" loading.

#### Description

The definition of the end caps is per drawing 4012001-382, Figure 12. Two end caps are required, one at each end of the 12 to 6 o'clock strut. The end caps are identical in construction except that the scroll end attachment pads are located on opposite sides. The opposite side location of the scroll end pads makes for a right- and left-hand part. Wrought material, 17-4 PH, was used in their manufacture. The structure was a weldment fabrication of sheet stock with machined pads and flanges. The general shape, when looking down on a plane view, is that of a thick "T" consisting of a face plate (the top cross of the "T") for frame mounting and two vertical plates (the vertical leg of "T") for sandwiching the strut ends. An "L" shaped flange was located at the end of the face plate for attachment to the cold-side sector and rear frame. A network of beams to the side of the "T" form the scroll attachment pad, see Figures 21 and 40.

#### Mounting

The end cap is secured to the strut end by four 1/4-28 shear-tensile bolts and six 10-32 tensile bolts running through the vertical plates and strut, see Figures 21 and 40. These bolts all have a dual purpose in that they are common to the different components which attach at the 12 and 6 o'clock strut ends.

#### Loading

The strut end caps react or transfer all component loads at the 12 and 6 o'clock strut ends. The major loads at each end cap are as follows:

1. Rear frame lift - 400 pounds
2. Exit louver vertical component - 2000 pounds
3. Exit louver horizontal component - 2000 pounds
4. The major strut end vertical shear - 6000 pounds
5. The scroll end attachment loading normal to scroll flange - 512 pounds and vertical in place of the scroll flange - 1118 pounds
6. The rear frame stator torque shear at each strut end - 1000 pounds

## Design

The general approach was a lightweight wrought fabricated structure. Material (17-4 PH) was chosen because its properties were compatible with stresses encountered and mainly because this material was already being used in the fabrication of the 3 o'clock strut. The use of the same material eliminated the additional cost of procuring and certifying another material. The surfaces to which joining components were to be bolted were made thick with large tolerances to assure machining clean-up. All welds were required to be 100 percent sheet thickness penetrated, effecting a more efficient lightweight structure. This 100-percent penetration requirement made it possible not to derate the weld joint because of the customary 100-percent root penetration standard, Figure 12.

The main structure of the cap is the plates, Item 12 of Figure 12, Zone J-3. These two plates sandwich the major strut ends transferring the strut load to the fan mounting attachment pad (face plate, Item 13). The face plate was welded to the vertical plates, forming a "T" structure. The face plates were tied in with the vertical plates by two through right angle gussets, Items 6 and 7 of Figure 12. Two "L" shaped side stiffeners, Items 9 and 10, were welded to the face plate and gussets. These stiffeners share in distributing the mount loads and form a "U" channel beam sharing in the transfer of the rear frame exit louver loads to the fan mount. An "L" shaped flange was attached to the face plate, stiffeners, and vertical plates to form the cold-side sector and rear frame attachment flange.

The vertical plates were spaced by an "L" shaped gusset which also attaches to the rear frame attachment flange. Side pads for attachment of the hot-side sector were placed on the outer face of one of the vertical plates. To attach and support the scroll end loading, a network of beams was added to the side of the end cap, see Figure 12, Zone J-3.

The brace (Item 17) extends from the edge of the face plate to scroll end mounting plate supporting the vertical loading. Two "U" channel beams (Items 3 and 18) were connected between the vertical plate and the scroll end mounting plate which react the bending moment induced in the torsion in Item 17. This induced moment results from the offset scroll end vertical load. A through bolt hole was placed between and at the upper flanges of the "U" channels to provide a firm attachment to the strut and opposite vertical plate.

## Stresses

The stresses in the end cap structure are small except for those in the beams supporting the scroll end mount loads, Figure 12, Items 3, 14, 17, and 18 of the exploded view - Zone J-3. The maximum stresses

induced in the brace (Item 17), assuming all of the vertical shear is taken by this member, are 77,000 psi in bending, with the associated beam shear of 26,000 psi. The stresses exist 1.5 inches out from the center of scroll end attachment plate at the joint between Items 17 and 14. The bending stresses at the large end of this brace are smaller, being 53,000 psi in bending and 13,400 psi in shear. The channels (Items 3 and 18) react the induced moment resulting from the offset scroll end load. The stresses in the channel, assuming Item 3 alone and not including Item 18, reacting the torsional moment are largest at the plate, being 37,337 psi in bending and 8040 psi in beam shear. All other stresses existing in the end cap are less than 22,000 psi in bending and 26,500 psi in shear. The allowable 0.2-percent stress is 127,000 psi, making the above stress more than acceptable.

### BRACKET-DOME MOUNTING

#### Function

The function of the dome mounting bracket is to attach and support the 9 o'clock side dome half at its center portion.

#### Description

The definition is per drawing 4012001-387, Figure 13. It is a wrought AL10AT titanium sheet fabrication which provides four of the six mounting pads with integral floating nuts to which the dome center is secured. It also has a four-hole attachment pad by which it is secured to the frame hub.

#### Mounting

The bracket is positioned astride the 9 o'clock strut at the hub and is attached by the same four 10-32 through bolts which attach the strut top cap to the hub, Figure 42.

#### Design

The general approach was a lightweight, stiff-wrought fabricated structure. AL10AT titanium (0.030-inc' stock thickness) material was chosen because this material was available and being used in the fabrication of the hot- and cold-side sections. The four pads to which the dome attaches are machined with reference to the brackets' four-hole securing pad surface, thus minimizing induced assembly stresses in the dome. Floating locknuts allowing 0.030-inch misalignment are used at each of the four dome mounting hole locations because these nuts are inaccessible when the rotor is secured to the frame.

### Material

The material used was Al10AT wrought titanium, see the Material section for its properties.

### Stresses

The maximum stress occurring in this bracket is 5000 psi in bending located at the securing bolts.

## WEIGHT

### Objective

The objective weight for the front frame was 100 pounds.

### Actual Versus Calculated

The calculated weight is based on the maximum dimensional tolerances and is tabulated below along with the actual overall scale weight for the frame.

<u>Component</u>	<u>Calculated Pounds</u>	<u>Scale Actual Pounds</u>
Major Strut	33.00	37
9 o'clock Strut	4.80	
Hub and Minor Strut	30.00	
Cold-Side Sector	13.51 (0.03 Wall) 17.42 (0.06 Wall)	
Hot-Side Sector	5.30	
End Caps	4.73	
Dome	3.80	
Bracket	0.28	
Miscellaneous Hardware	4.28	
Total	<u>99.60</u>	<u>103</u>

The frame weight is in excess of the objective 100 pounds by 3 pounds. The weight can be accounted for through the change made in the wall thickness (0.030 to 0.060 inch) of the cold-side sector tube. This wall thickness change was made to facilitate the tube spinning. The increased wall thickness added 3.91 pounds to the frame actual weight.

## MANUFACTURING PROBLEMS AND THEIR SOLUTIONS

The manufacturing gave rise to many different problems of interest because of the five different materials involved. These materials were Al10AT titanium wrought 17-4 PH steel, cast 17-4 PH steel, cast A356 aluminum, and glass cloth epoxy laminate, Figures 6 and 42. The prime vendor for the manufacture was Twigg Industries, Division of Altamil Corporation, with subcontractors of interest being Spincraft for the titanium spinning, Waukesha Foundry Company for the 17-4 PH hub casting, and Atkins and Merrill for the fiber glass epoxy dome. The General Electric Company supplied the A356 aluminum strut castings which were cast by Oberdorfer Foundry in Syracuse, New York.

### Titanium Alloy

Al10AT titanium sheet and bar were used in the manufacture of the 9 o'clock side dome center support bracket and the hot- and cold-side sectors. No problems were encountered in the manufacture of the bracket but the same cannot be said for sectors. The gussets were 0.015 inch thick and could not be formed with simple tooling because of radius cracking and skin wrinkling. Heated holding dies with subsequent annealing straightening cycles were required to obtain a flat part. The "L" shaped flanges of the hot and cold sectors gave no problems because they were machined from rolled bar. The 0.015-inch-thick shear panels of the cold-side sector also required heated holding dies to prevent skin wrinkling. The real problem was in the spinning of the hot- and cold-side sector tubes. These tubes, approximately 2.5-inch diameter and 0.030-inch wall thickness, were formed to a 33.9-inch radius. First attempts failed because of circumferential splitting. A photomicrograph showed oxide and transformed beta structure existing on the base metal surface, Figure 43. This beta transformation seriously affects the physical properties (primarily ductility) and was to be avoided. This transformation occurs at temperatures of 1820<sup>o</sup>F or higher, indicating part temperature to be higher than necessary to facilitate spinning. The presence of titanium oxide on the metal surface makes the surface very brittle and could easily precipitate sheet fracture. A review of industry standards for this temperature control left much to be desired, for it seemed solely a visual procedure on the part of the operator. Temperature was a function of the color of the material and the operator would adjust the heating equipment accordingly.

It was also noted that spinning is strictly a craft with results dependent upon the operator's ability to feel the metal flow under his applied pressure. It was found that industry did not have a good feel on possible parameters which would help in their field, such as, "the rate of metal deformation for various material, thicknesses, and the

like". Continued efforts to spin the 0.03-inch sheet resulted in continued failure. Once the part was completely spun, and upon the release of the spinning tools, the shape actually reversed back on itself, making for somewhat of an opposite-hand part. The spinnings now had become a limiting item in the front frame manufacture.

The sheet thickness was increased to 0.06 inch because for the cold-side 2.5 inch diameter tube it was felt that the pressure required to move the material during spinning actually pulled the sheet apart, thus the splitting. This increase in thickness, along with a 25-percent increase in the chuck rpm, produced the first useable part. The hot-side tube wall thickness of 0.030 inch was spun successfully with the increase in chuck speed.

It is concluded from the limited spinning encountered, that, if given sufficient time and dollars for development, industry can spin almost anything. It is also concluded that for successful continued use of titanium in large structural spinnings, the spinning industry must develop a much more exacting control of their processes and techniques.

To make the 2.5-inch-diameter tube which is less than 180 degrees in circumference required only one spinning. The spinning was 360 degrees in circumference with a cross section one-half of that of the 2.5 inch diameter tube. This 360 degree circle was cut into halves, mated, and girth welded. Before this spinning could be welded, a series of annealing straightening cycles were required. This consisted of placing the spinning on the steel spinning chuck, weighing the part, and placing all in the furnace. This method of straightening was used for all of the titanium parts. Upon completing the welding of the tube and before it could be used in the cold-side assembly, four annealing straightening cycles were required. These straightening cycles were simple to perform but were costly when considering the involved lost time. The next problem encountered was weld distortion of the 0.015-inch-thick gussets when attaching them to the tube. Fit-up of the gusset to the tube outside diameter was critical, with the greatest distortion resulting at the locations of worst fit-up. It should be noted, however, that whatever the fit-up, there was much distorting of the gussets. It was decided not to remove these distorted gussets for fear of the possible scraping of the tubes. This decision was considered to be very reasonable because of our already late delivery and problem filled spinning experience.

Additional gusset distortion resulted when welding them to the flanges. The attachment of the gussets to the shear panels was changed from fusion tack to spot welding to eliminate additional distortion. To remove the worst areas of distortion, 0.030-inch-thick doublers were riveted to some gusset webs. The rivets used were 1/16-inch-diameter

AN rivets, see Figure 21.

Still another problem arose from the handling of the frame. Welds in the gusset and at the attachment of the gussets to the flanges were being cracked when bumped. These cracks were occurring in the weld affected zones adjacent to the welds. It was found that a slight surface oxide existed in these areas. It is to be noted that titanium oxide is very brittle. The oxide along with the thin stock thickness produced the crack susceptible condition. These cracks were all weld repairable and gave good experience in repair of thin titanium sheet. It was found that the area to be welded had to be bagged and totally covered with argon gas to produce a trouble-free repair.

The manufacture of the hot-side sector experienced the same difficulties as did the cold-side sector. It is believed that the gusset distortion was greater on the hot-side sector because less mass in the gussets provided a poorer heat sink than that of the cold-side sector.

To minimize gusset weld distortion and the handling problems on subsequent manufacture, the 0.015-inch sheet should be increased to 0.030 inch. This thickness increase will provide a rugged part with a larger heat sink. The employment of a cooling technique, keeping adjacent parts at a relatively lower temperature, may also help.

Even though great care was exercised in shielding the welded areas with argon, surface oxides continued to form. This surface oxide formation must be eliminated if large lightweight titanium sheet metal weldment structures are to survive. The development of an economical weld shielding process and procedure, which totally eliminates surface oxide formation during welding, should be initiated. This process and procedure must also be adaptable in field repair.

#### Wrought 17-4 PH Alloy

Wrought 17-4 PH steel was used in the manufacture of the end caps and the 3 o'clock strut without difficulty. This material was excellent in formability and weldability with only minor distortion during the welding. No weld cracks were experienced. One item of interest is the method employed in the welding processing of the end caps. This welding was scheduled in alternating steps of welding followed by straightening, which resulted in a relatively warp-free part requiring minor final straightening.

#### Cast 17-4 PH Alloy

No problems of concern were encountered in casting the 17-4 PH hub. It took only three pours to produce an acceptable part. The item of

real interest concerning the casting is the excellent properties achieved for this size casting using the 17-4 PH cast material and a 1025<sup>o</sup>F aging temperature (see the Material section). The Shaw casting process was used, resulting in an acceptable fourth and fifth casting on the third pouring. The first and second pourings had shrinkage and x-ray indications in the shaft and attachment projections. After a change in gating, the second pouring was found deficient in strength requirements. Again the gating was changed for the third pouring, which gave x-ray acceptable parts. These parts were heat treated and the fourth one was sectioned to obtain test specimens with results exceeding the physical properties requested, the fifth being a duplicate of the fourth x-rayed "sound" with the separately poured test bar exceeding requirements. See Appendix II for the "Instructions of the Hub Casting Metallurgical Acceptance, 4012154-969".

A summary of the method of acceptance is: the first good casting was to be x-rayed for interior integrity and zyglod for surface defects; test bars were to be poured separately for material heat acceptance (would the material respond to heat treatment); the casting was to be sectioned and test specimens pulled to guarantee minimum properties in the casting itself, and micro's were to be made at various locations for obtaining grain size and general comparison. Upon meeting the requirements above, the subsequent casting would be considered acceptable. Another area of interest is the fusion butt weld of the 3 o'clock wrought strut to the cast 17-4 PH alloy hub. This weld was achieved without problems, obtaining more than acceptable joint strength on the first welded simulated joint. Sample joints were made using the actual materials and the exact size and length of weld required in the frame fabrication. The weld was made with the cast and wrought materials in the annealed condition and aged at 1025<sup>o</sup>F for 1 hour after welding. Table 7 tabulates the results of tensile tests taken across the weld with the weld at the center of the 1-inch gauge length. All failures occurred in the cast metal side of the weld outside of the heat affected zone.

#### Cast A356 Alloy

A356 cast aluminum was used for the casting of the 9 and 12 to 6 o'clock struts. A green zircon sand mold was used in the casting of each. See Figures 44 and 45 for the general layout of the gating used.

Both struts were cast with excess material envelope on the leading and trailing edges to facilitate wall filling. The metallurgical aspects of the struts are covered in addition to the drawing notes by Instruction A-4012154-967, see Appendix II. Item 3 of this instruction requires that the first acceptable struts be sectioned and specimens for testing be taken from the casting and the minimum properties tabulated under item 4 be met. These specimens are in addition to separately

cast bar of Item 5 which are used to indicate an acceptable heat of material and its ability to respond to heat treating.

The pouring of the 9 o'clock strut was done with the chord in a horizontal attitude. The vertical attitude was attempted on the second, third, and fourth pourings without success, and because the vendor felt it best, the balance of the pourings were made in the horizontal attitude. It took a total of 12 pourings to produce an acceptable casting. The problems encountered were typical for castings except that the required thin walls of 0.08 to 0.140 inch no doubt added to the difficulty experienced. The problems were miss-runs, dross and gas holes in excess of acceptance. By continually changing the gating, adding chills and increasing the size of the gas catchers, an acceptable casting was obtained. Vacuum was tried in the pouring of the third attempt only and was not used on subsequent pourings because it yielded no advantage. Upon obtaining an acceptable casting, core holes were plugged, x-rayed, and accepted, see Figure 46.

The heat treat presented no problems; only a slight straightening to remove excess bow was required. The walls were prevented from puckering during the cold water quench by using the procedure worked out during the treating of the major strut. The physical properties of the first 9 o'clock strut are tabulated in Table 3.

The leading and trailing edges were machined to contour and the wall surfaces hand polished to a 125 rms sanded finish by the casting vendor. The strut was field inspected, accepted, and shipped to the prime vendor.

The major 12 to 6 o'clock strut (74 inches long, 13 inches chord, and 1.1 inch thick with 0.08- to 0.140-inch-thick walls) was quite cumbersome to handle. It was cast in the vertical attitude, (see Figure 45) for the general casting gating layout. The same problems of miss-runs, dross, gas, and added shrinkage were encountered in the casting of the strut, see Figure 47. It took 11 pours to obtain an acceptable casting and 14 pours to obtain an acceptable part. The acceptable strut was accomplished through continual changes in the gating, addition of chills, increasing the areas of the gas catchers, and the addition of a fiber glass cloth screen along the trailing edge gate. The welding of the wall plugs (closing the core holes) required the development of the welder's technique and the use of Utectic 190 aluminum flux and argon gas backup. This flux was mixed with denatured alcohol and painted in and around the core hole both inner and outer wall surfaces. The problem encountered was a resulting weld oxide line resulting in a wall thickness of questionable magnitude. This defect in the weld was repaired, see Figure 46.

The major problem was encountered during the cold water quench of the major strut. The strut walls puckered inward upon being quenched and could not be corrected. Using 56 psig internal hydraulic pressure with external wall supports, the attempt to remove this puckering failed to return the wall to its original flat surface. This puckering of the walls was eliminated in subsequent quenching by the process of inserting a 1/8-inch-diameter stainless steel tubing in each strut half drain vent hole prior to solutioning. This tube was of sufficient length to remain above the water surface. During quenching, this open passage provided by the tube allowed air to fill the inner strut cavity in place of water or steam. The air filled the cavity at a faster rate than the water or steam, minimizing the pressure differential across the strut walls. Steam generated at the opening of the drain hole was thought to prevent the immediate filling of the cavity with either steam or water, thus creating a sufficient pressure across the strut wall to produce the puckering.

This simple procedure, which prevented puckering on the subsequent quenching operations, should be the breakthrough required to make large hollow high-strength thin-wall casting feasible.

Only slight straightening of the strut was required after quenching to remove bow.

The actual weight of the final machined part was 4 pounds over the calculated maximum weight. This over-weight indicated that the wall thickness was not maintained and that additional development was required to obtain lightweight thin-walled castings.

#### Fabric and Epoxy Laminate

Glass fabric and epoxy resin laminating binder were used in the manufacture of the dome. The problems encountered in its manufacture were more of the nature of vendors' interpretation of the drawing intent. A quarter test dome was made prior to committing the actual dome to manufacture for the purpose of assuring first piece quality. Sectioning of the test quadrant revealed the misinterpretation of the continuous shear web of the rib structure in certain ribs. Testing of this section also resulted in changing the binder from polyester to epoxy to achieve a stronger primary to secondary lay-up bond.

The primary structure appeared like a large salad bowl having three layers of cloth and epoxy resin. It was vacuum bagged and cured. The secondary structure included the addition of the ribbing to the solid bowl, again vacuum bagged and cured. The opening in the surface for the strut passage was hand cut into the dome by employing developed cutout templets. These templets were traced on the dome contour and hand cut.

Additional fitting of the cutouts to fit the strut contour was required at assembly, see Figure 32. After the fitting, the raw edges were healed with the epoxy binder. The first dome was made in error by the reversal of the 3 and 9 o'clock cutouts. The ribbing on the 9 o'clock side is continuous over the strut, therefore, it was cut away by the deeper 3 o'clock strut cutout. The upper bearing plate material was changed from titanium to the easily worked 321 stainless steel alloy because the titanium would not lay flat or stay bonded in place. This change was made to eliminate the required new heated straightening die, compounding an already late delivery. Horse-shoe-type reinforcing doublers (0.01 inch thick, 321 stainless steel alloy) were added to the 3 and 9 o'clock strut opening for the purpose of eliminating a possible crack producing area, see Figure 33. These doublers were bonded to the primary salad bowl using 1564 glass cloth and Epon 828 binder.

To protect the outer surface of the dome from erosion, it was coated with two different materials. The first coat was Laminar X-500 - 8-W-5 material sprayed on a clean surface. The surface was sanded smooth applying the second and last material of Laminar X-500 - 8-B-6 Rodome coating. This last coating was black in color. Two applications of the Rodome coating were used for maximum protection.

#### Frame Assembly

One problem was encountered in the assembly of the components forming the frame. This problem was the lack of the required interference fit between the major strut trailing edge caps and the bearing surface of the hub. To correct this lack of interference, a shim was inserted and secured using the cap attaching bolts, see Figure 22.

## TESTING

The front frame was assembled as a component part of the LF-2 fan test vehicle (Figure 48) and tested on 23 December 1964 in the General Electric Company's outdoor wing fan installation. This testing was terminated in December 1964 upon completion of the rotor 100 percent speed check-out phase of a three-phase scheduled LF-2 demonstration testing program. The termination of the testing was brought about by the rotor turbine shroud failures. The shroud experienced a critical vibratory mode which caused clashing of the shroud bumper blocks which induced high additive stresses resulting in shroud disintegration. The shroud fragments caused some minor dents and scratches to the front frame and punched a hole through the 6 o'clock end of the cold-side sector. This hole is in the web of the scroll end seal attachment flange and can easily be repaired. This end of the cold-side sector formed a trap which caught and held the shroud fragments up to the point of being pushed on through the skin.

Another problem noted in the frame was cracking of the cold side titanium 0.015 inch stock thickness gussets. Thirty percent of these gussets were cracked in the flange and web, as shown in Figure 49. This seemed to be a continuance of the same cracking problem experienced during manufacture and in handling during assembly. It is felt that the assembled fabrication stresses, induced by the uncontrollable fusion weld distortions, could be the major cause of this cracking. The design is not without fault, for these gussets could be improved by increasing the stock thickness from 0.015 to 0.030 inch, minimizing the welding problems; another improvement would be the continuance of the inner leg flange as shown in Figure 50, reducing a stress concentration area. These gussets will be repaired prior to subsequent LF-2 demonstration testing. The front frame temperature data taken during testing along with the location of the thermocouples are shown in Figure 51. The two strain measuring gauges were located on the major strut cap. These gauges proved to be faulty and the strut cap stresses were not obtained. These gauges will be repaired prior to subsequent testing. The frame performance to date with the limited testing is satisfactory. The basic design is sound and will perform as expected up to 115-percent fan speed.

## CONCLUSIONS AND RECOMMENDATIONS

1. The use of 0.015-inch titanium stock thickness for gussets should be avoided if the method of attachment is to be by fusion welding.

The uncontrollable weld distortion experienced when attaching the gussets to the cold- and hot-side sectors resulted in a poor appearance unit. Also, the welded joints in the gussets themselves and the attachment welds proved to be quite brittle because of a slight surface oxidation and was a constant repair problem during manufacture and in handling the frame. It is recommended that all gusset stock thicknesses be increased to a minimum of 0.030 inch, regardless of material used, so as to improve the manufacturing and handling problems.

2. The spinning of large 70-inch diameters using 0.030-inch stock thickness (AllOT1) titanium material proved quite time consuming and expensive. The state of the art was being stretched in these spinnings, which added to the time and cost. It is recommended that a technology program be initiated to develop the needed large-diameter spinning parameters necessary to reduce scrapage and improve their quality.
3. The 17-4 PH cast hub and wrought strut fabrication demonstrates the excellent combination of strength and ductility achievable in the cast 17-4 PH alloy. The ease of welding both the wrought and cast to wrought joints was also demonstrated with excellent weld joint strengths in the as-welded and aged-only condition. This material should be considered in all future designs requiring a composite of cast and wrought fabrications.
4. The subdivision of the frame into separate components has its greatest advantage in providing selective use of different materials, and various vendors, thus utilizing the potential of each. It is recommended that all large framed components employ the subdivided construction for best use of materials and utilization of a larger number, different skilled, and size of vendor. Employing a number of vendors to accomplish one end does reduce the manufacturing cycle.

DISTRIBUTION

US Army Materiel Command	3
US Army Mobility Command	3
US Army Aviation Materiel Command	4
Chief of R&D, DA	1
US Army Aviation Materiel Laboratories	20
US Army R&D Group (Europe)	2
US Army Test and Evaluation Command	1
US Army Combat Developments Command, Fort Belvoir	2
US Army Combat Developments Command Transportation Agency	1
US Army Combat Developments Command Experimentation Command	3
US Army Transportation School	1
US Army Aviation School	1
US Army Infantry Center	2
US Army Tank-Automotive Center	2
US Army Aviation Maintenance Center	2
US Army Aviation Test Board	3
US Army Aviation Test Activity	2
Air Force Flight Test Center, Edwards AFB	1
US Army Field Office, AFSC, Andrews AFB	1
Air Force Systems Command, Wright-Patterson AFB	1
Systems Engineering Group (RTD), Wright-Patterson AFB	3
Bureau of Naval Weapons, DN	4
Chief of Naval Research	1
US Naval Air Station, Norfolk	1
Commandant of the Marine Corps	1
Ames Research Center, NASA	1
Lewis Research Center, NASA	1
NASA Representative, Scientific and Technical Information Facility	2
Research Analysis Corporation	1
NAFEC Library (FAA)	2
Bureau of Safety, Civil Aeronautics Board	2
Federal Aviation Agency, Washington, D. C.	1
Defense Documentation Center	20

APPENDIX I  
FIGURES 1 THROUGH 51

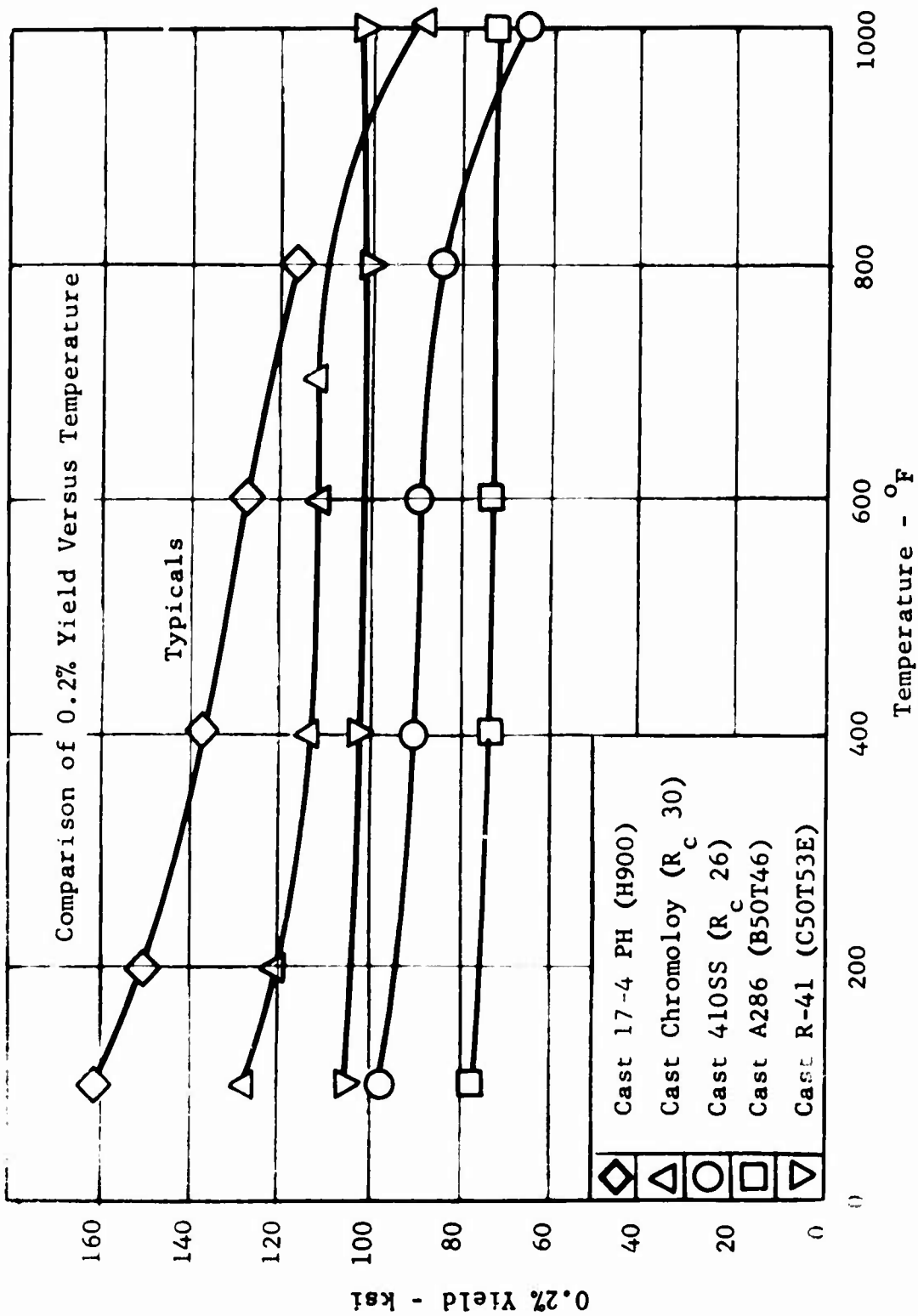


Figure 1. Comparison of 0.2 Percent Yield Versus Temperature for Various Alloys.

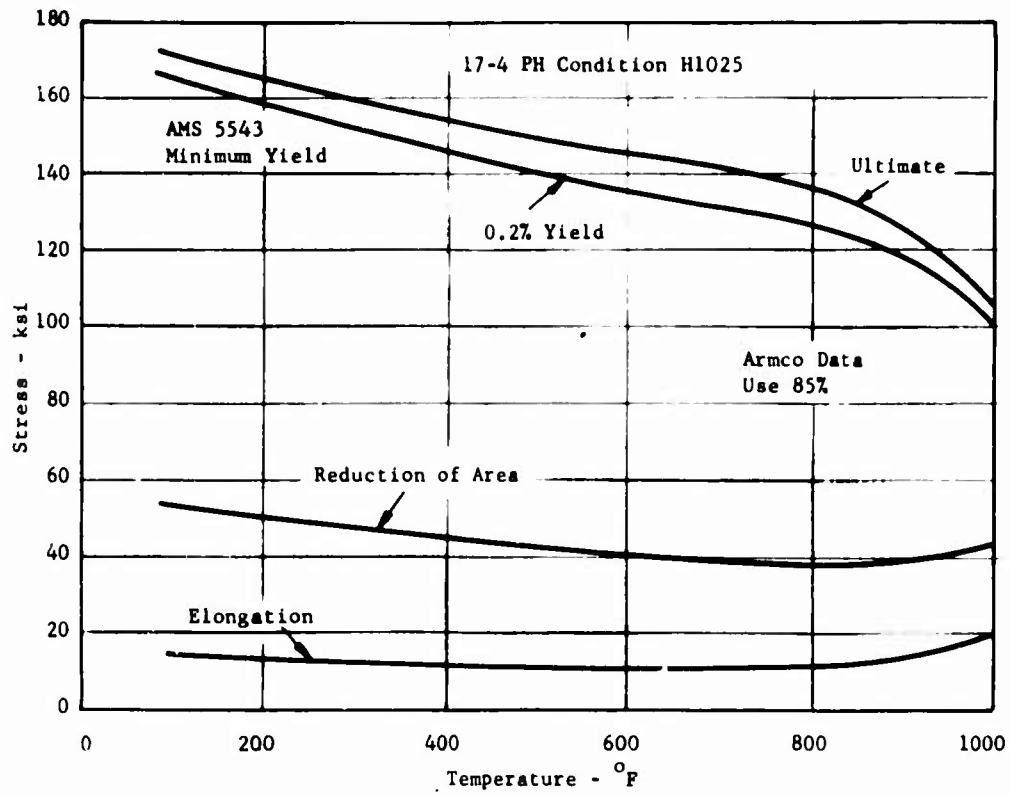


Figure 2. Room Temperature Tensile Properties of 17-4 PH Material Condition for 1 Hour at 1025°F.

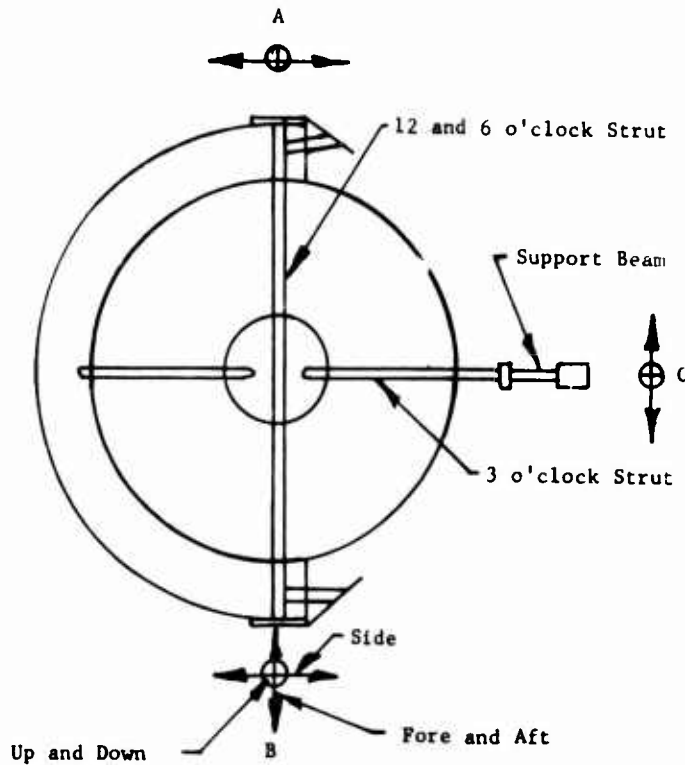


Figure 3. Plane View of LF-2 Front Frame Showing its Mounting and Restraint at each Mount.

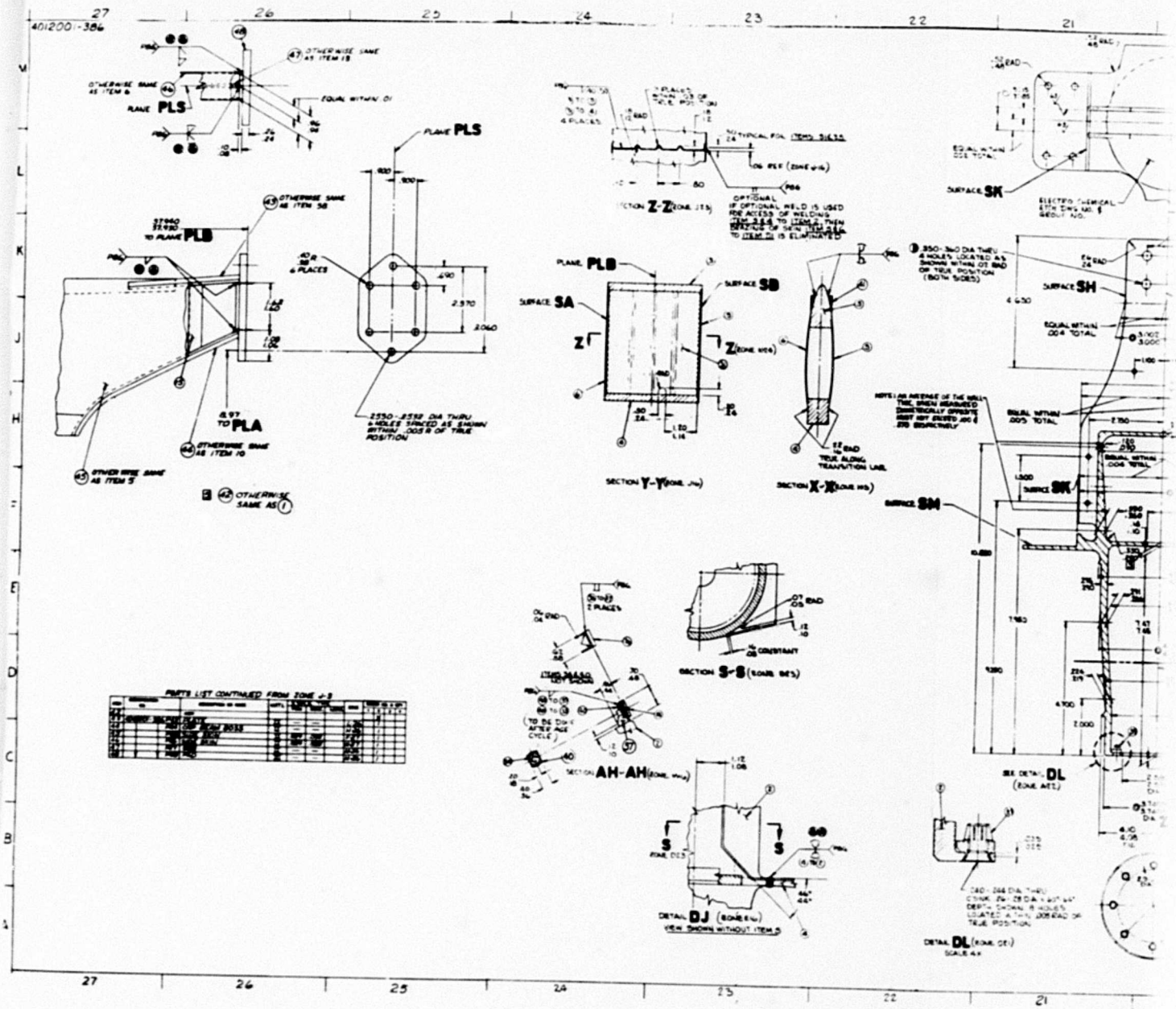
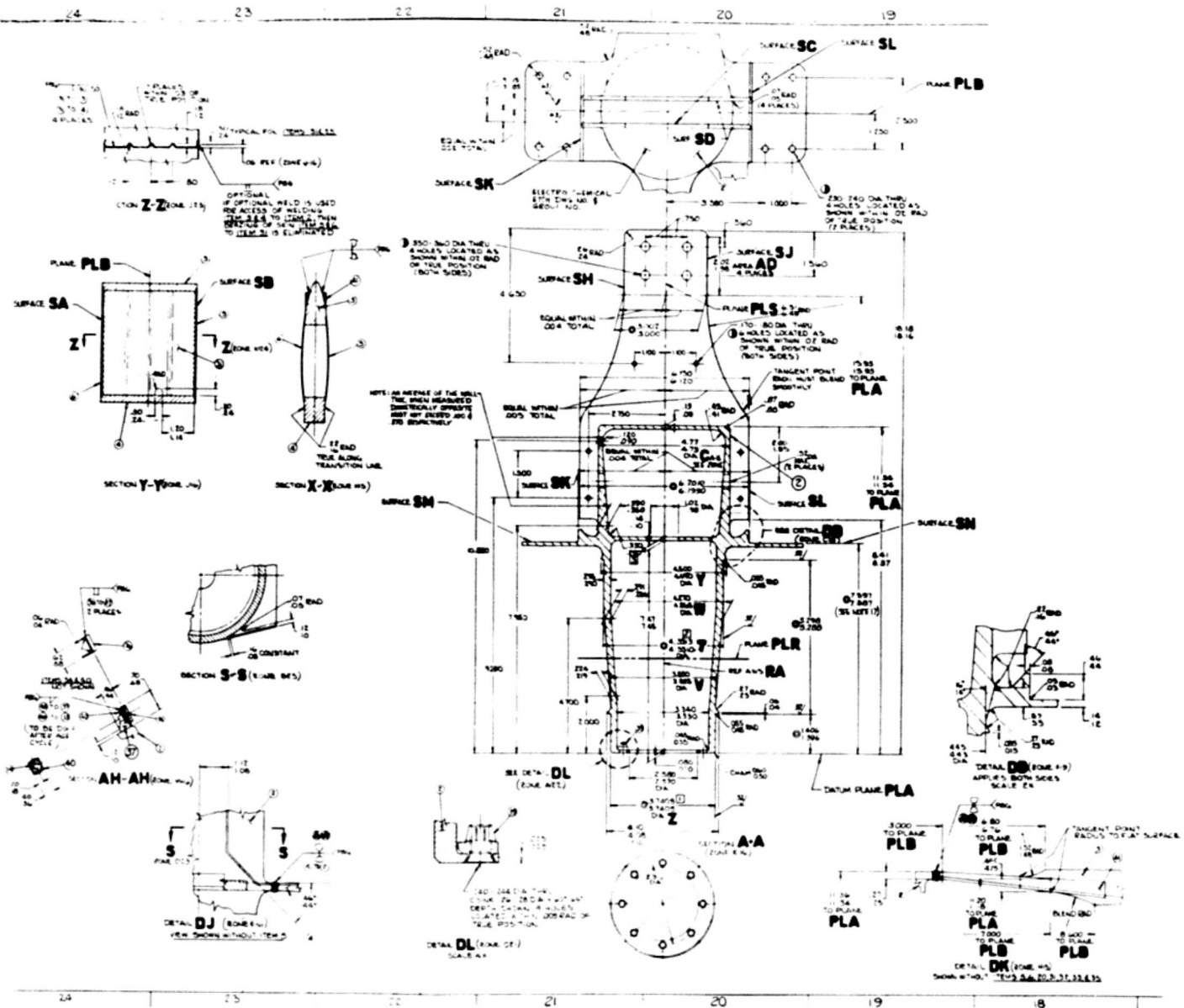


Figure 4. Drawing 4012001-386, Hub and Minor Strut 3 o'clock LF-2 Front Frame. Sheet 1 of 2

A



re 4. Drawing 4012001-386, Hub and Minor Strut  
 3 o'clock LF-2 Front Frame,  
 Sheet 1 of 2

**B**



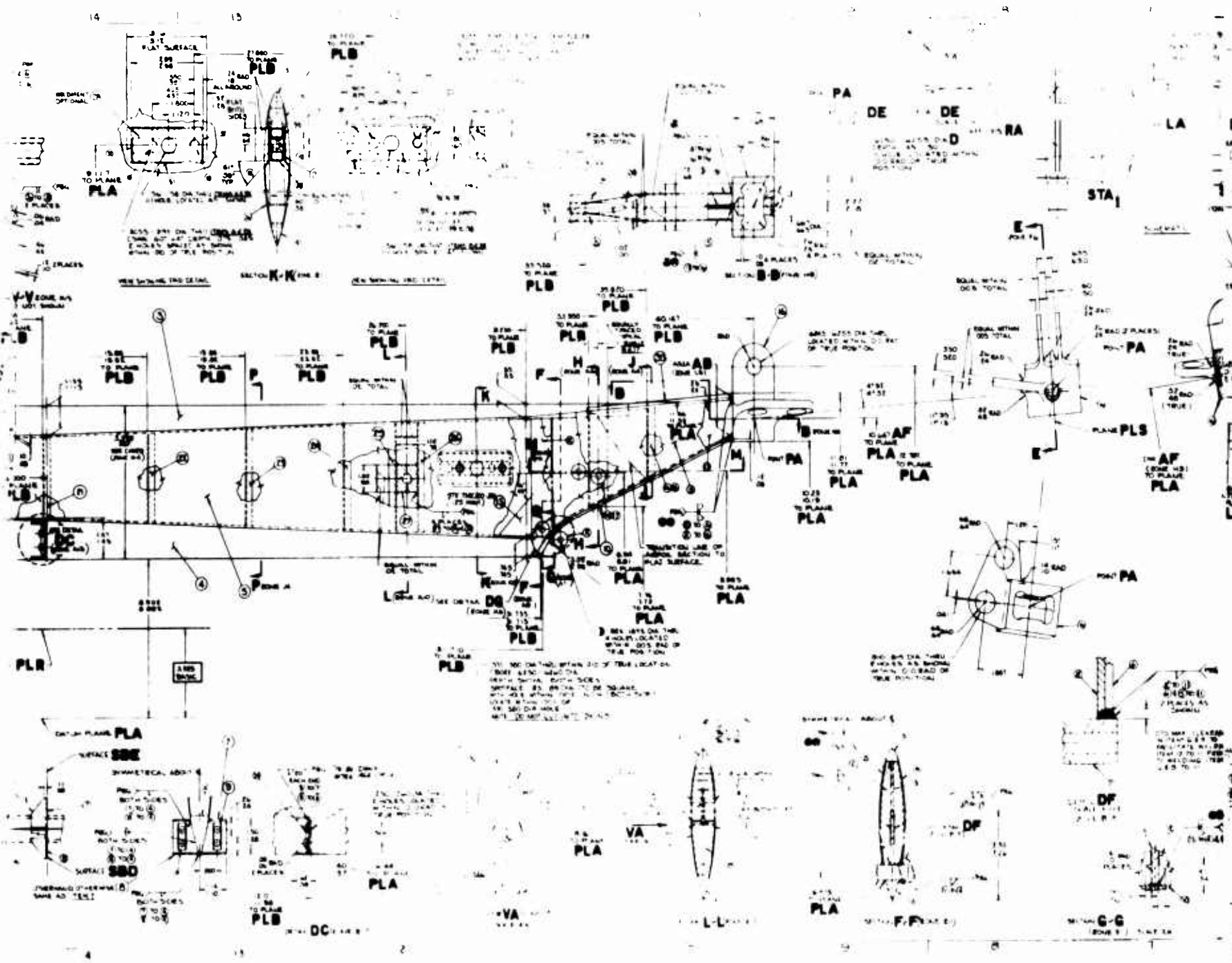


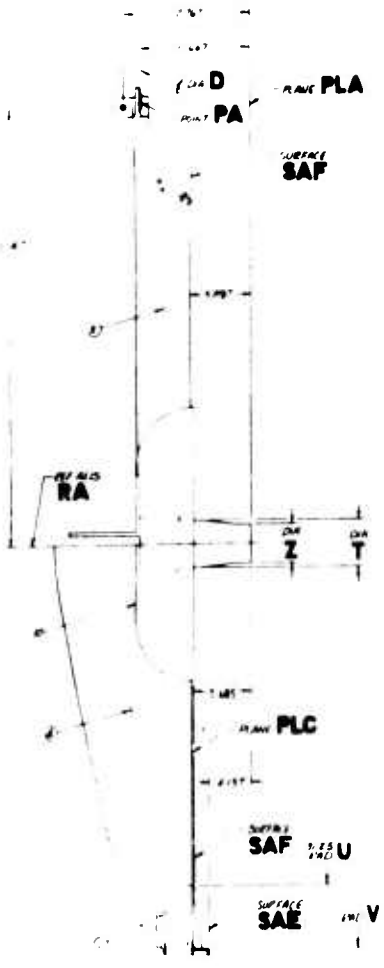
Figure 4. Drawing 4012001-386, Hub and Minor Strut  
3 o'clock LF-2 Front Frame  
Sheet 2 of 2

B





3:00



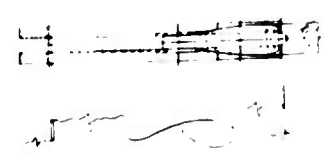
12:00

SECTION J-J ROTATED  
ZONE H (11)  
SCALE 1/4

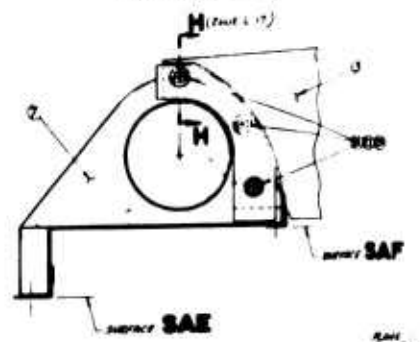
8:00



SECTION H-H (ZONE 15)



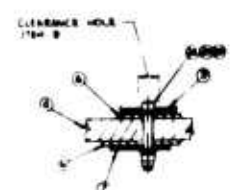
DETAIL DC (ZONE 14)



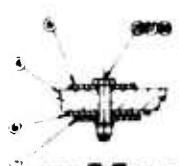
SCALE PLS

9:00

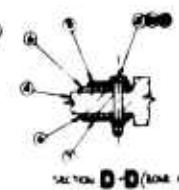
SEE DETAIL DC (ZONE 14)



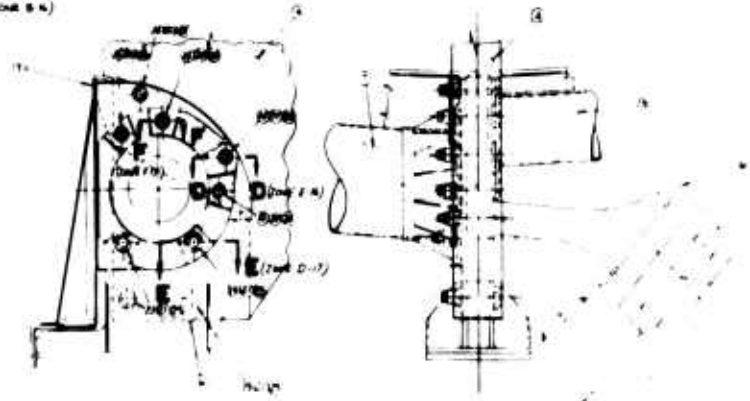
SECTION F-F (ZONE 13)



SECTION E-E (ZONE 14)



SECTION D-D (ZONE 14)



DETAIL DE (ZONE 12)

SCALE 1/2  
12:00 EXCEPT  
INDICATED

A

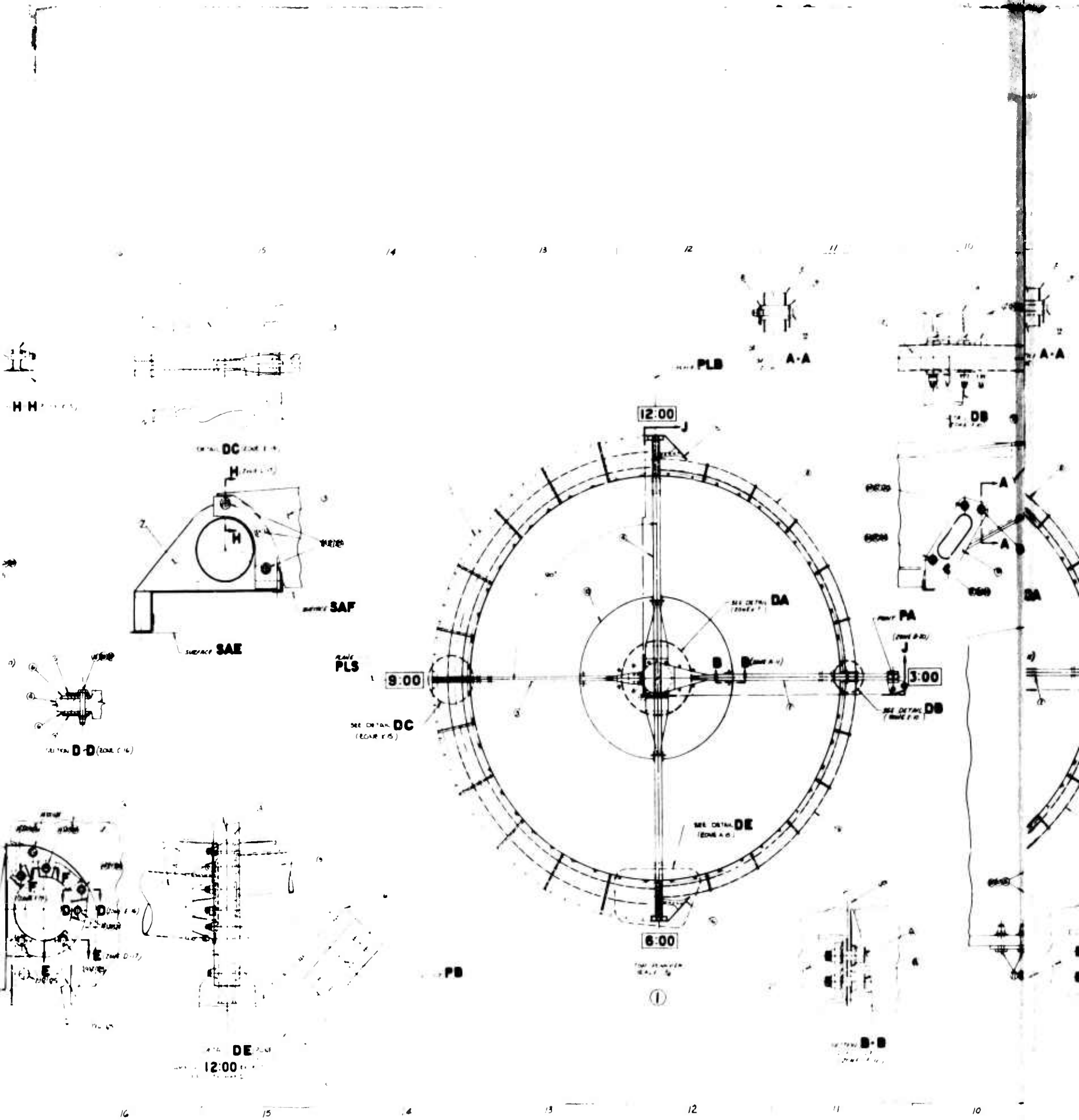
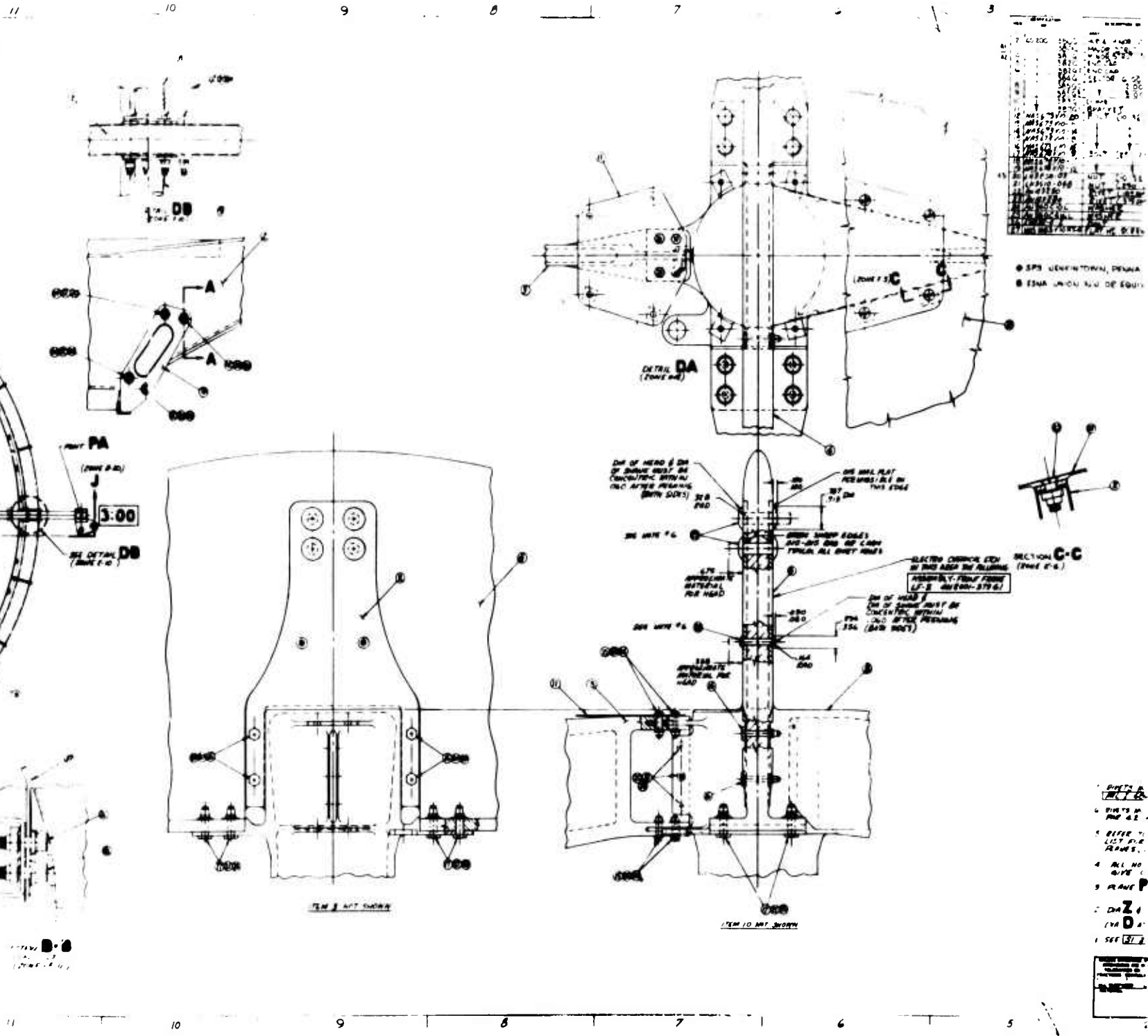


Figure 5. Drawing 4012001-379, Assembly Front Frame 379.

**B**



NO.	DESCRIPTION	QTY.	UNIT
1	...	...	...
2	...	...	...
3	...	...	...
4	...	...	...
5	...	...	...
6	...	...	...
7	...	...	...
8	...	...	...
9	...	...	...
10	...	...	...
11	...	...	...
12	...	...	...
13	...	...	...
14	...	...	...
15	...	...	...
16	...	...	...
17	...	...	...
18	...	...	...
19	...	...	...
20	...	...	...
21	...	...	...
22	...	...	...
23	...	...	...
24	...	...	...
25	...	...	...
26	...	...	...
27	...	...	...
28	...	...	...
29	...	...	...
30	...	...	...
31	...	...	...
32	...	...	...
33	...	...	...
34	...	...	...
35	...	...	...
36	...	...	...
37	...	...	...
38	...	...	...
39	...	...	...
40	...	...	...
41	...	...	...
42	...	...	...
43	...	...	...
44	...	...	...
45	...	...	...
46	...	...	...
47	...	...	...
48	...	...	...
49	...	...	...
50	...	...	...

● SPS LENS/TOWN, DENIA  
 ● SPSA UNICU N.O. DE EQU

SECTION C-C  
 (ZONE C-C)

- 1. PARTS A
- 2. PARTS B
- 3. REFER TO LIST FOR PARTS
- 4. ALL NO. GIVE
- 5. PLANE P
- 6. DIA Z
- 7. DIA D
- 8. SEE BT 2

Assembly Front Frame LF-2.

C



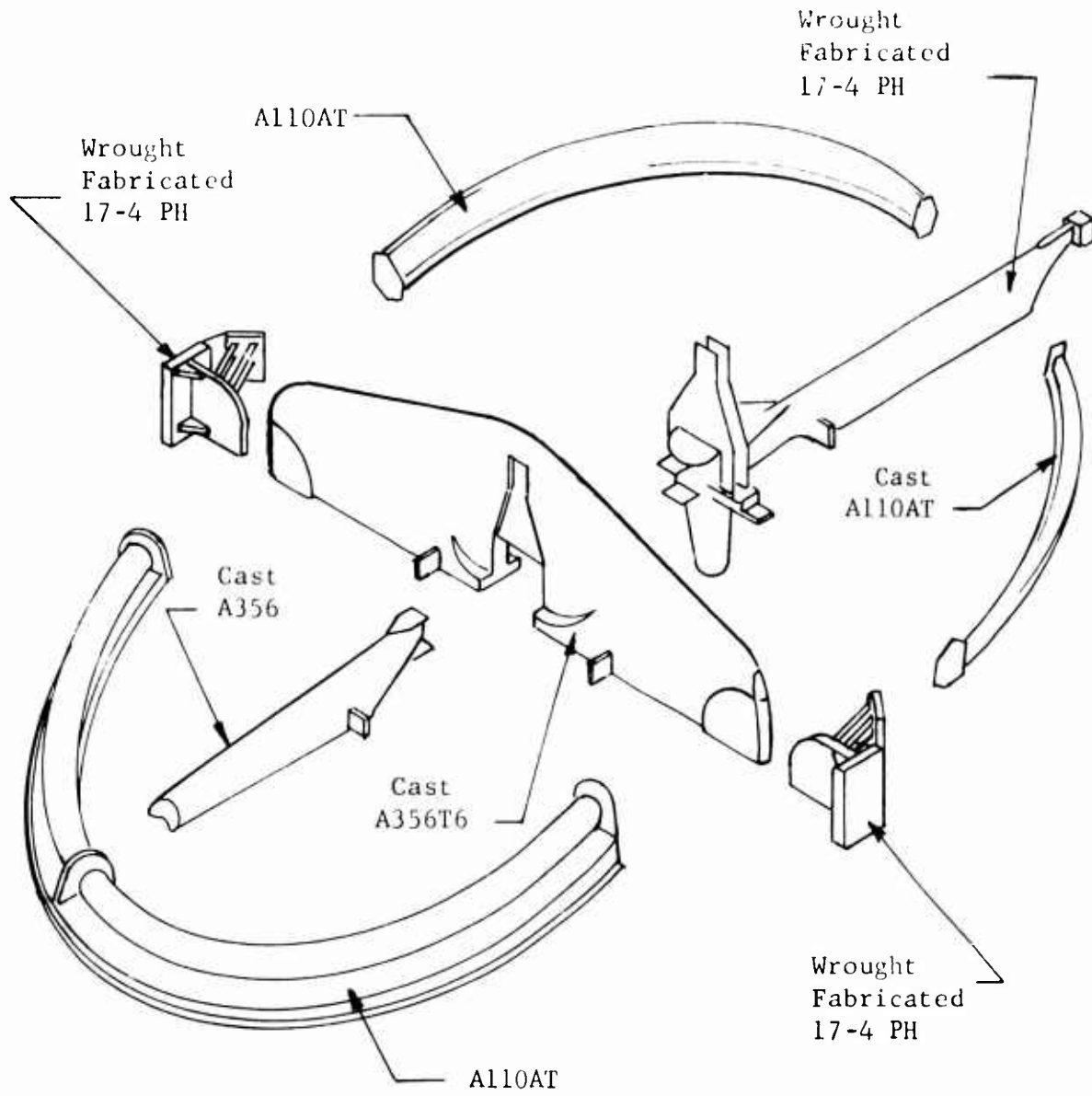


Figure 6. VTOL LF-2 Front Frame Components; Reinforced Glass Plastic Dome Not Shown; Assembled Frame is 6 Feet in Diameter.



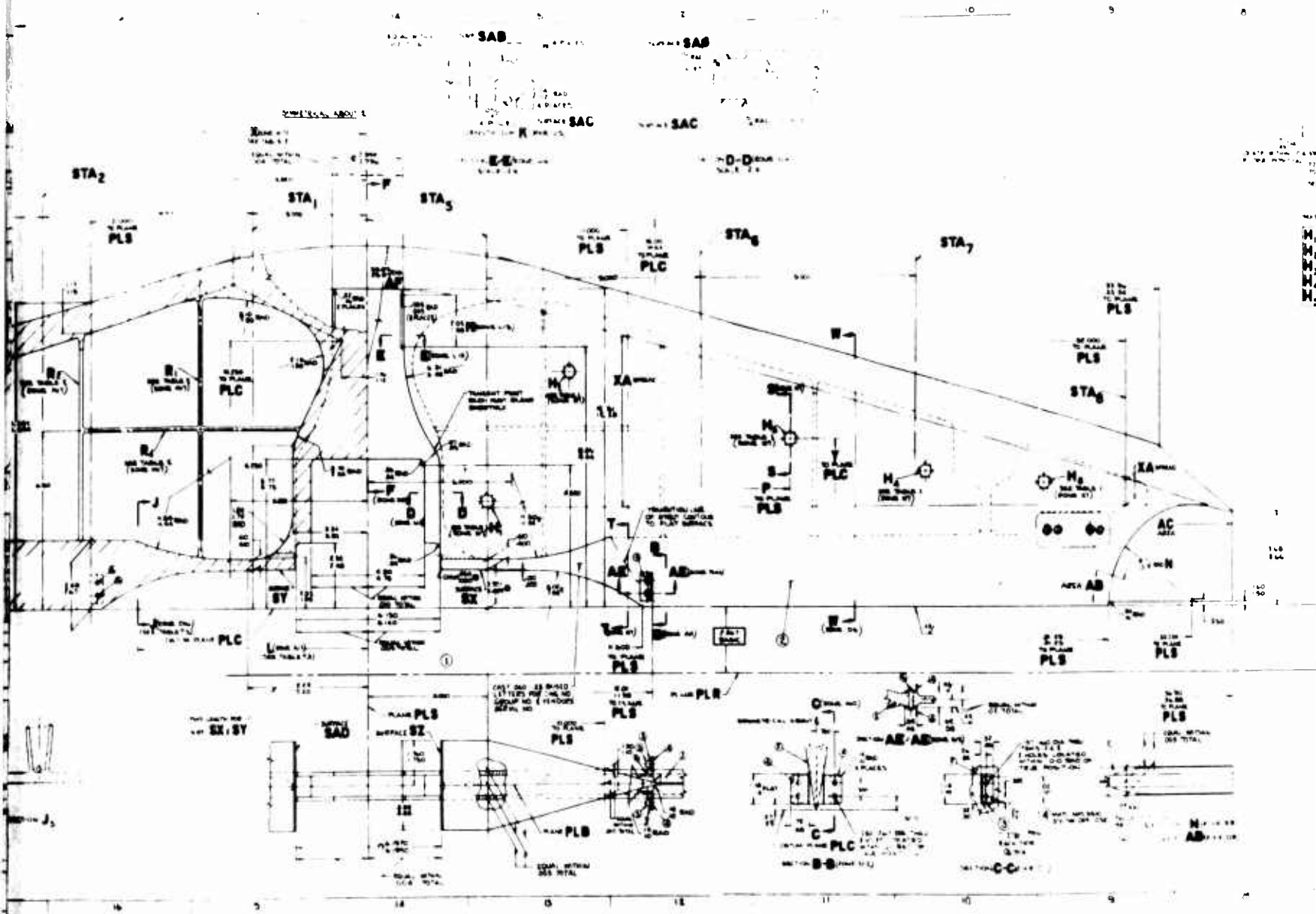


Figure 7. Drawing 4012001-380, Major Strut 12 to 6 o'clock Front Frame LF-2.

**B**

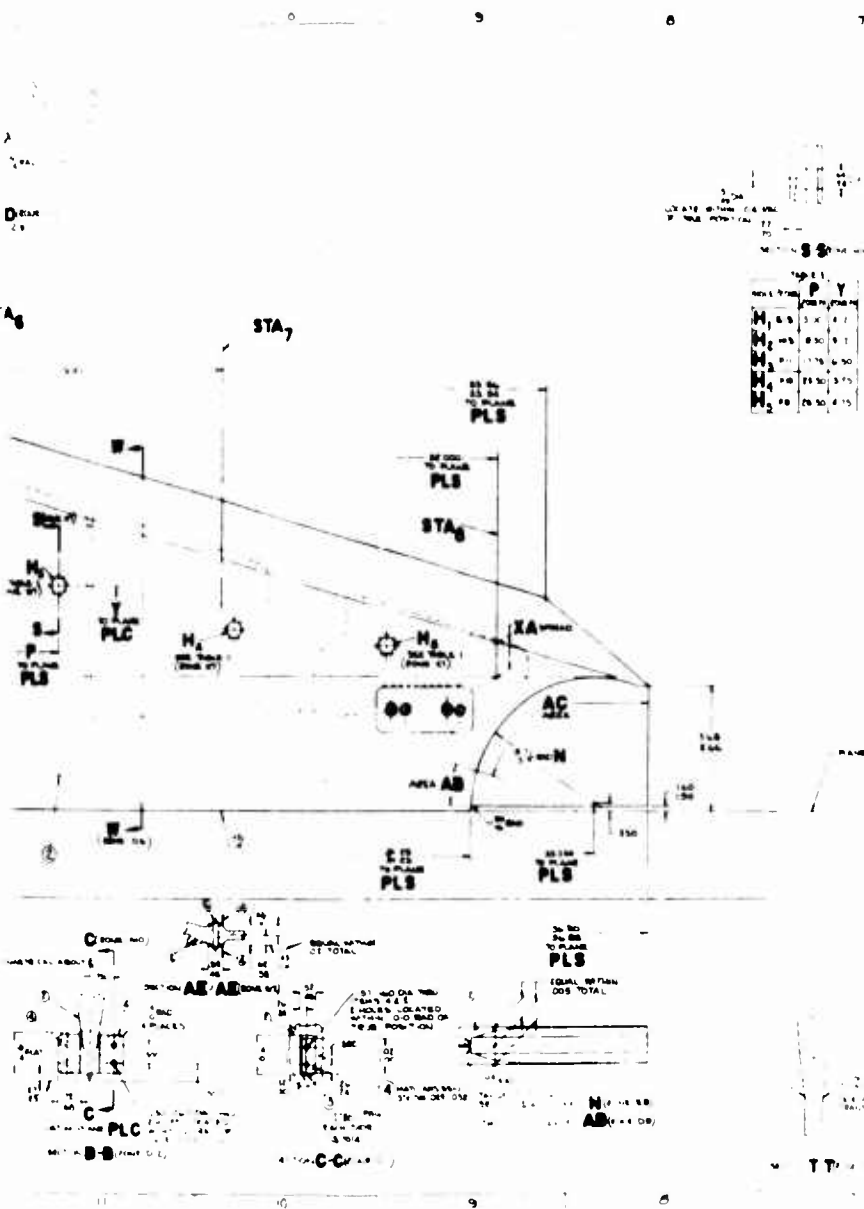


TABLE 1  
 H<sub>1</sub> 5.5 3.5 4.7  
 H<sub>2</sub> 2.5 8.50 9.1  
 H<sub>3</sub> 1.75 6.50  
 H<sub>4</sub> 1.50 7.50 5.75  
 H<sub>5</sub> 1.50 7.50 4.75

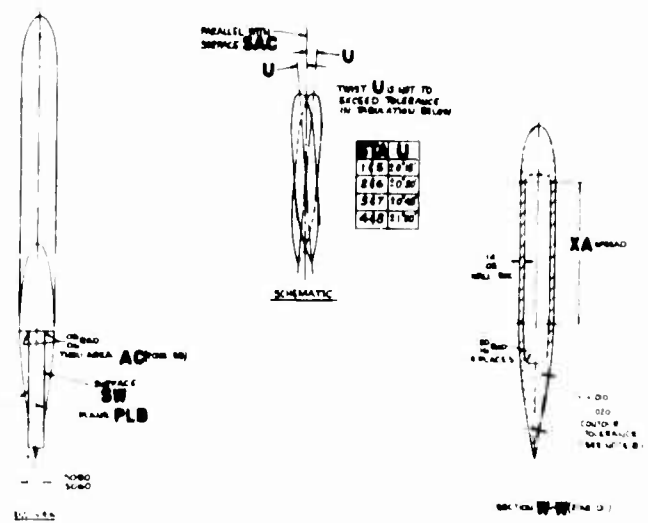
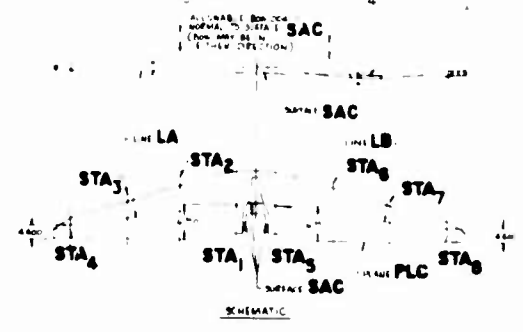
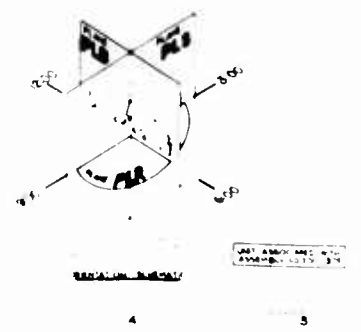
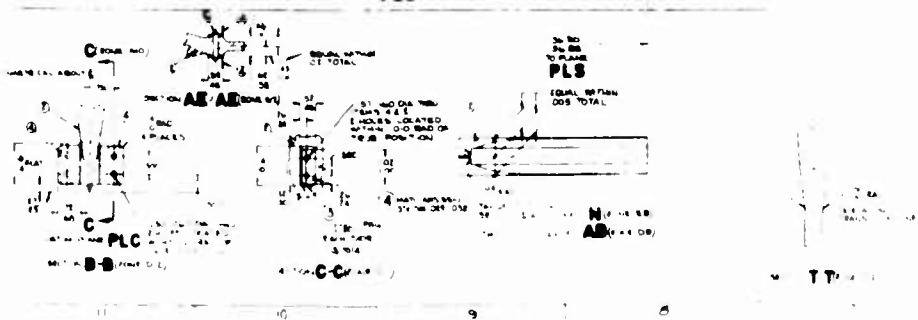


TABLE 2  
 1.68 2.74  
 2.66 2.04  
 3.47 1.24  
 4.48 1.10

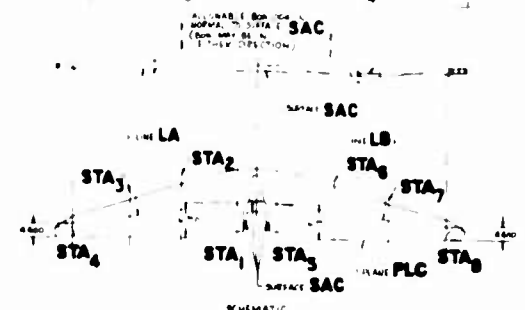


Major Strut 12 to 6 o'clock

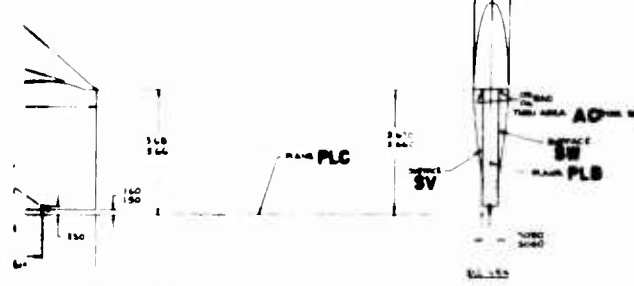
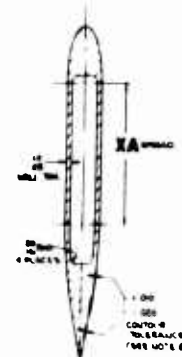
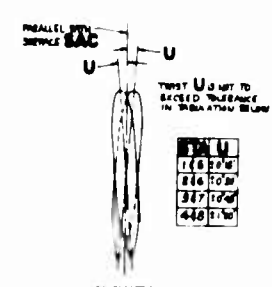
C

TABLE I

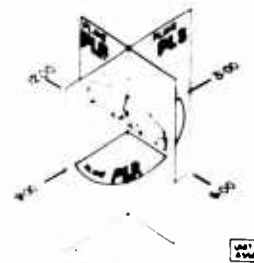
NO.	FROM	P	Y
1	100	100	100
2	100	100	100
3	100	100	100
4	100	100	100
5	100	100	100
6	100	100	100
7	100	100	100
8	100	100	100
9	100	100	100
10	100	100	100



- 1. DIMENSIONS FROM CENTER OF GRAVITY UNLESS OTHERWISE SPECIFIED.
- 2. DIMENSIONS FROM CENTER OF GRAVITY UNLESS OTHERWISE SPECIFIED.
- 3. DIMENSIONS FROM CENTER OF GRAVITY UNLESS OTHERWISE SPECIFIED.
- 4. DIMENSIONS FROM CENTER OF GRAVITY UNLESS OTHERWISE SPECIFIED.
- 5. DIMENSIONS FROM CENTER OF GRAVITY UNLESS OTHERWISE SPECIFIED.
- 6. DIMENSIONS FROM CENTER OF GRAVITY UNLESS OTHERWISE SPECIFIED.
- 7. DIMENSIONS FROM CENTER OF GRAVITY UNLESS OTHERWISE SPECIFIED.
- 8. DIMENSIONS FROM CENTER OF GRAVITY UNLESS OTHERWISE SPECIFIED.
- 9. DIMENSIONS FROM CENTER OF GRAVITY UNLESS OTHERWISE SPECIFIED.
- 10. DIMENSIONS FROM CENTER OF GRAVITY UNLESS OTHERWISE SPECIFIED.



- 1. SURFACE SY, SW IS TO BE PARALLEL TO PLANE PLB (1) IN EACH VIEW OF THIS DRAWING.
- 2. SURFACE SX, SAG IS PARALLEL WITHIN 0.0004" AND SQUARE WITH SURFACE SAC WITHIN 0.015" TOTAL.
- 3. SURFACE SX, SY IS PARALLEL TO SAME PLANE WITHIN 0.015" TOTAL SQUARE WITH SURFACE SAC WITHIN 0.015" TOTAL.
- 4. SURFACE SAC, SAG IS PARALLEL TO PLANE PLB (1) PART BE PARALLEL TO EACH OTHER WITHIN 0.0004".
- 5. FLUORESCENT POREMOUNT & SUBSEQUENT INSPECTION CHECKED BY X-RAY SHALL NOT BE CONSIDERED UNLESS BY (SEE NOTE 1).
- 6. INTERNAL DIMENSIONS TO BE TAKEN UNLESS OTHERWISE SPECIFIED.
- 7. CAST PELLETS SHALL BE CALIBRATED WITHIN A TOLERANCE OF 0.0004" TO 0.0008" TO DIMENSIONS UNLESS OTHERWISE SPECIFIED.
- 8. BASIC CONTOUR OF SURFACE IS DETERMINED BY PRECISION MASTER (SEE DIM. 40.000 ± 0.000).
- 9. ALL CORNERING CURVED SURFACES OR CURVED STRAIGHT SURFACES SHOWN AS "TANGENT" MUST BLEND SMOOTHLY.
- 10. DIMENSIONS SHOWN ON OR RADII OF CURVED SURFACES UNLESS OTHERWISE SPECIFIED.
- 11. THIS SYMBOL (C) INDICATES NOTES AND DIMENSIONS OF PRIMARY IMPORTANCE.
- 12. DIMENSION TOLERANCES ARE NOT ACCUMULATIVE UNLESS INDICATED BY SURFACE TO TRUE POSITION.
- 13. DIMENSIONS WITHOUT TOLERANCES ARE BASIC AND DEFINE TRUE POSITION AND/OR TRUE CONTOUR.
- 14. TRUE POSITION IS THE EXACT LOCATION OF A POINT.
- 15. SEE (SEE NOTE 1) FOR INTERPRETATION OF DRAWING.



LAST REVISION WITH DIMENSION 40.000 ± 0.000

1	100	100	100
2	100	100	100
3	100	100	100
4	100	100	100
5	100	100	100
6	100	100	100
7	100	100	100
8	100	100	100
9	100	100	100
10	100	100	100

M  
L  
K  
J  
H  
F  
E  
D  
C  
B  
A

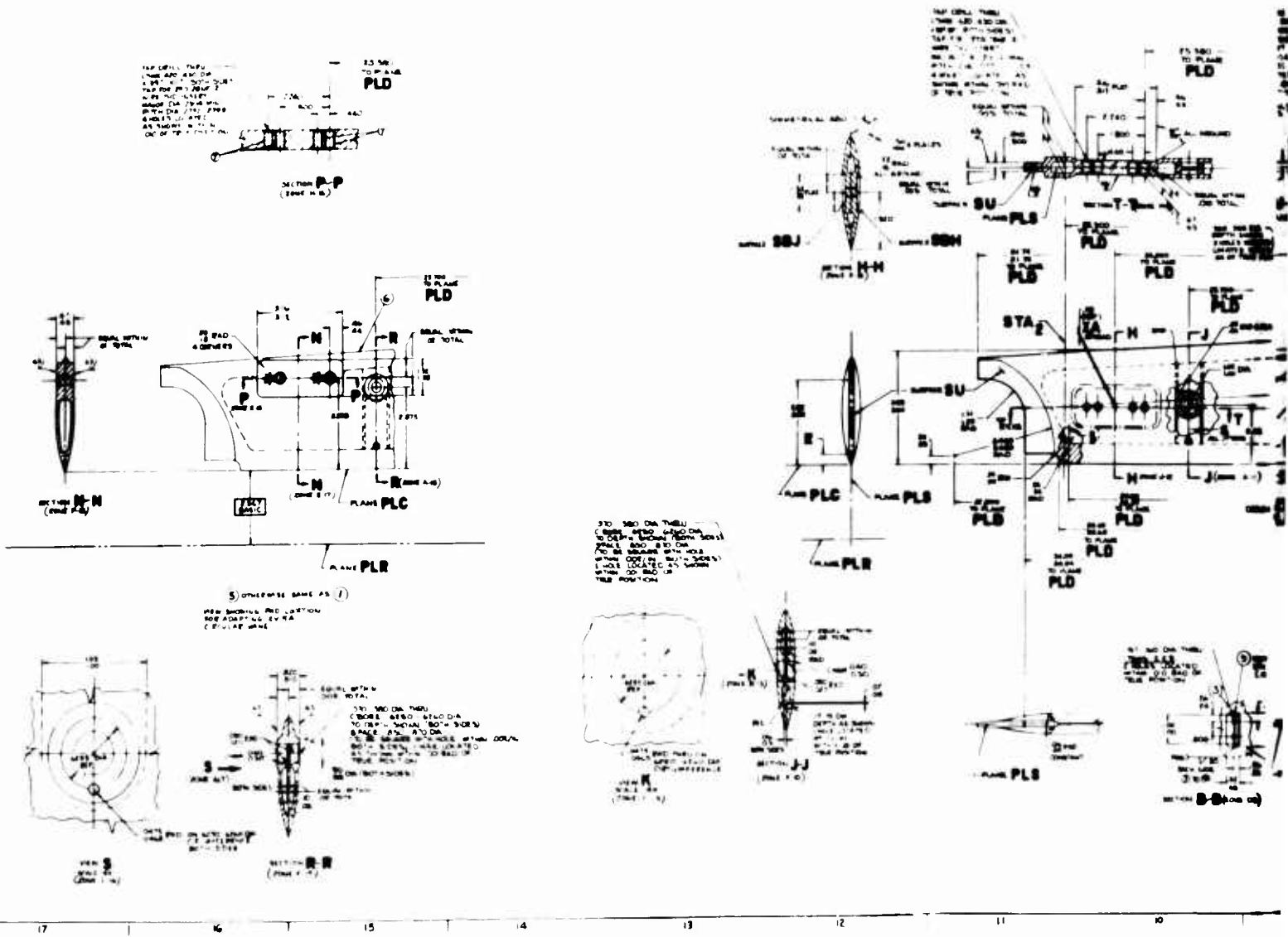


Figure 8. Dra' LF-

A

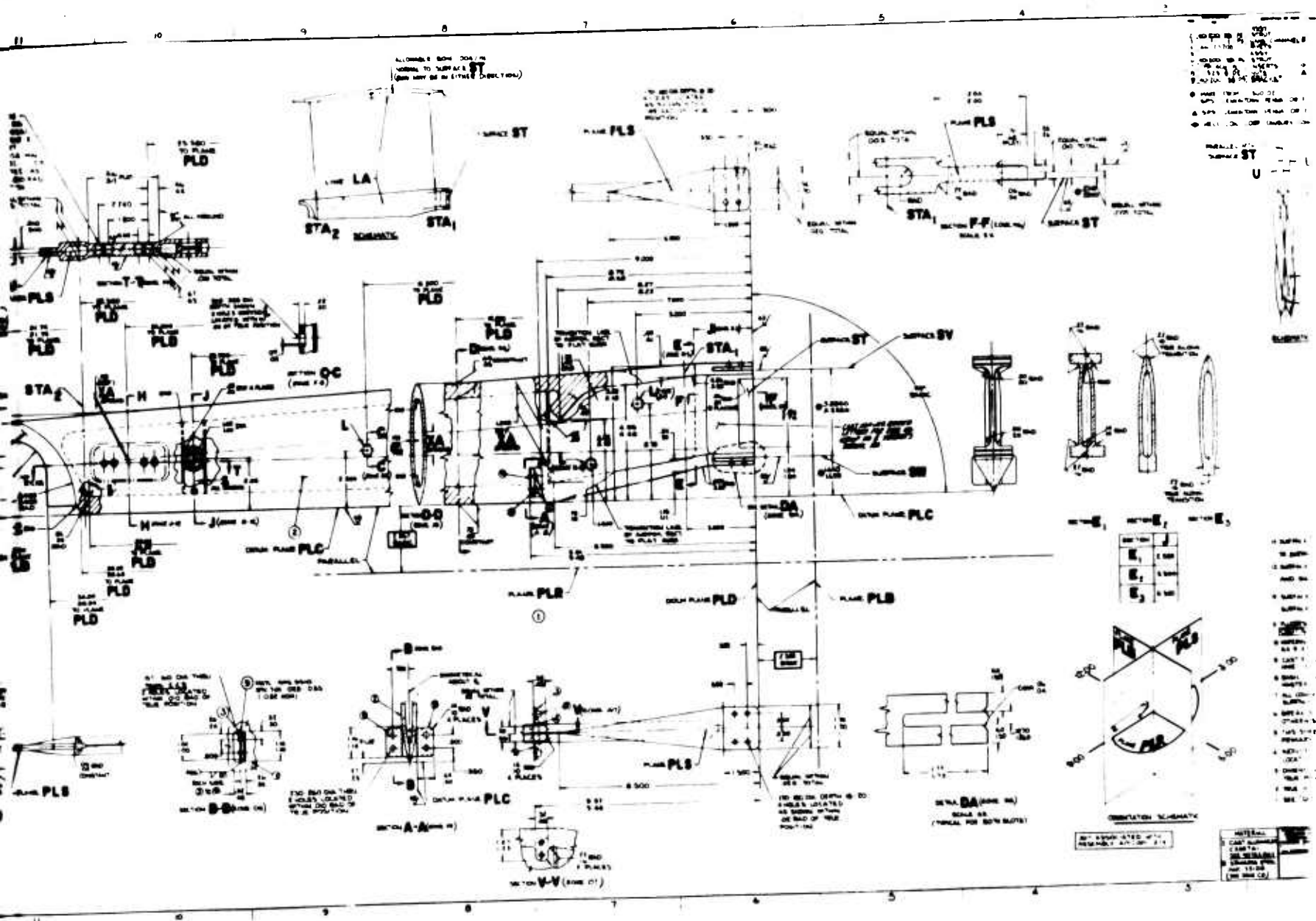
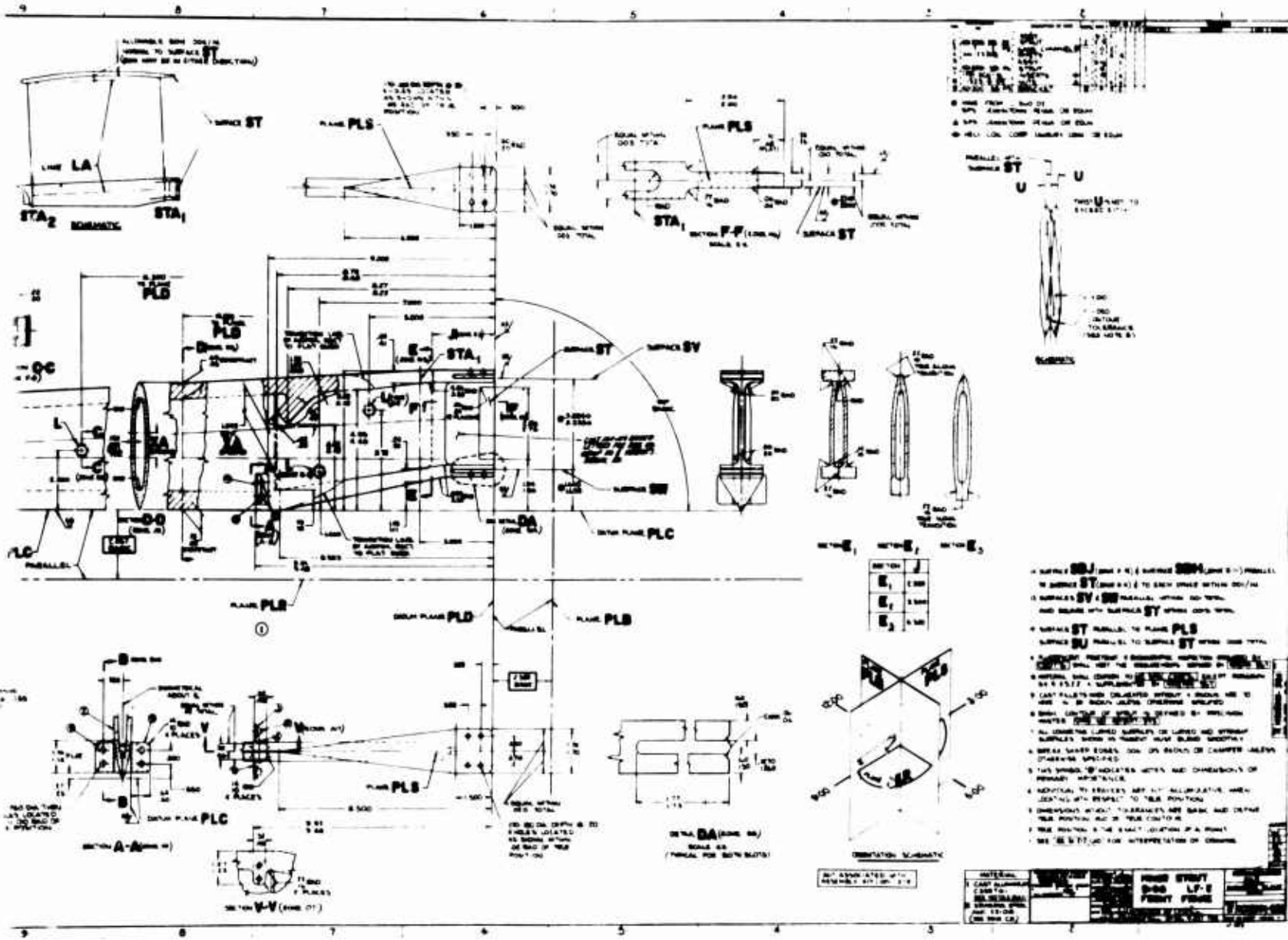


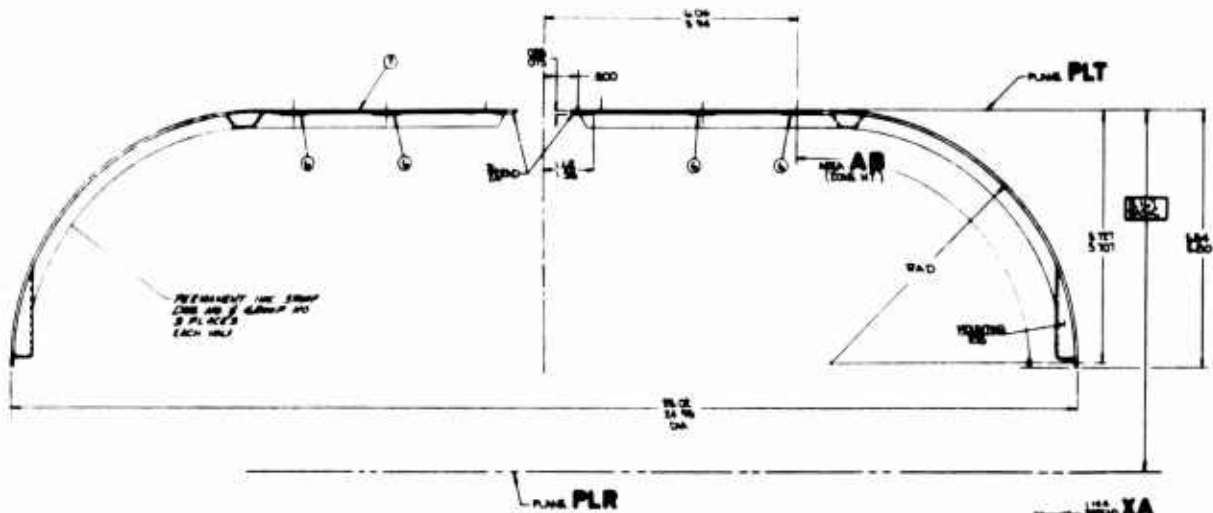
Figure 8. Drawing 4012001-381, Minor Strut 9 o'clock.  
LF-2 Front Frame

**B**

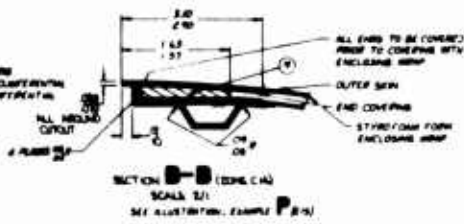
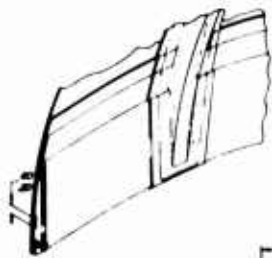


g 4012001-381, Minor Strut 9 o'clock.  
Front Frame

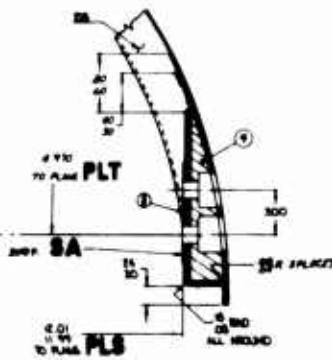
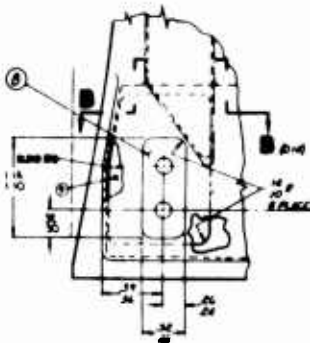
C



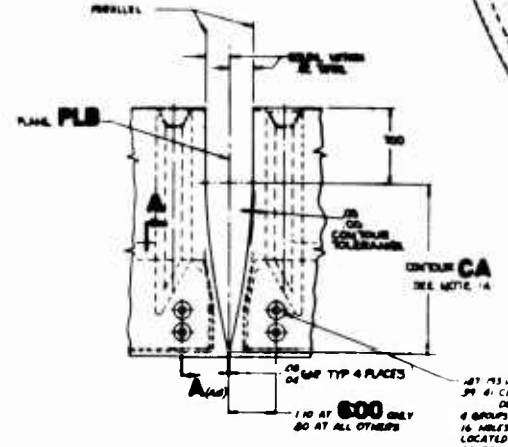
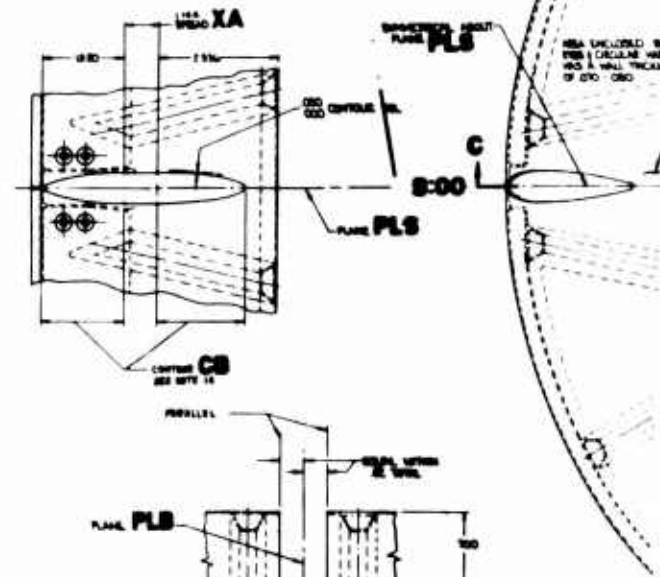
SECTION C-C (EDGE PL)



SECTION D-D (EDGE CA)  
SCALE 1/2"  
SEE ILLUSTRATION, EXAMPLE P-10



SECTION A-A (EDGE B1)  
SCALE 1/2"  
TYPICAL 8 PLACES  
SEE ILLUSTRATION, EXAMPLE P-10



VIEW VA (EDGE A1)  
TYPICAL OUTPUT AT 8:00:12:00

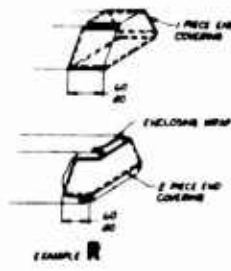
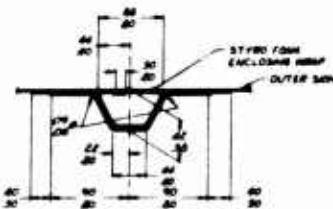
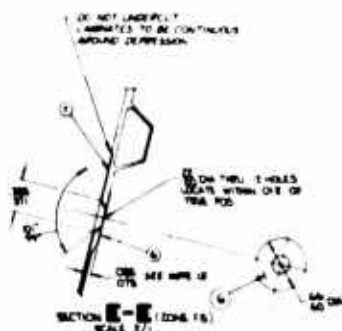
A



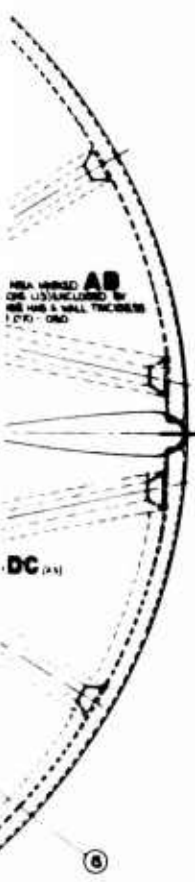
REV	DATE	BY	CHK	DESCRIPTION
1				ISSUED FOR CONSTRUCTION
2				RETRACED WITH 4874 ENL. PER 01-10-48-100



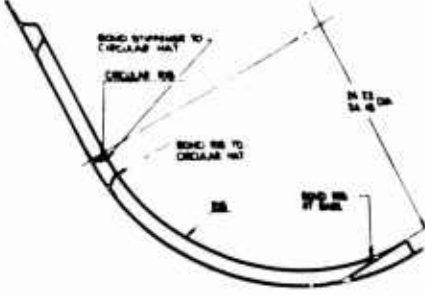
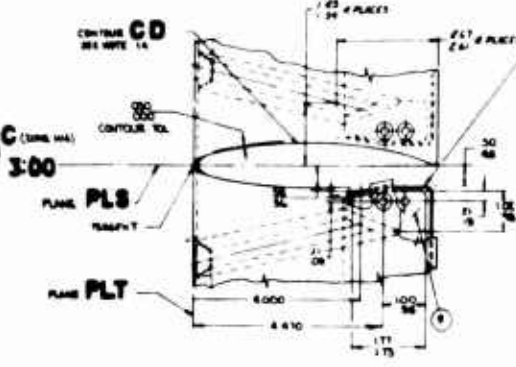
W-27 ASSEMBLY LOCATION



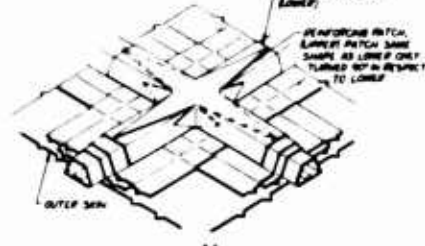
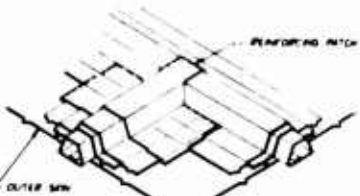
SECTION K-K (ENL. 1/2) SCALE 1/2  
STYRO FOAM CONSTRUCTION  
NOTE: ALL LINES TO BE COVERED, SEE EXAMPLE U-U, POINT TO CORNER WITH ENCLOSING MESH



NEAR WINGED ONE (3) UNCLASSED BY WPS AND WALL THICKNESS 1/2" - 0.80



SECTION J-J (ENL. 1/2) SCALE 1/2

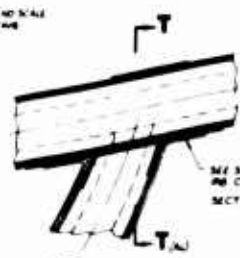


EXAMPLE S (LOOKING INTO) NO SCALE SHOWS A STYLE A JOINT CONNECTING TO ANOTHER STYLE A JOINT

EXAMPLE U (ENL. 1/2) NO SCALE (LOOKING INTO) SHOWS STYLE A JOINT CONNECTION NOTE: PERFORATED PATCHES



SECTION T-T (ENL. 1/2) SCALE 1/2 SHOWN WITH OUTER SKIN SEE ILLUSTRATION, EXAMPLE S



SECTION DC (ENL. 1/2) SCALE 1/2 SHOWN WITH OUTER SKIN REMOVED SEE ILLUSTRATION, EXAMPLE S

1. 4" ON OUTER CONTOUR
2. PERFORM METAL SURFACES PRIOR TO BONDING BY TITANIUM-PICKLE (THE USE OF CHLORINE COMPOUNDS ARE POSITIVELY PROHIBITED) ALUMINUM-ALODINE 600
3. WALL THICKNESS: 0.05" TYPICAL ALL AREAS EXCEPT ALL CORNER THICKENINGS (SEE NOTE 7) AND UNLESS OTHERWISE SPECIFIED ALL WALL AREAS ARE TO BE 3 PLY 0.05" WALL THICKNESS PER PLY
4. ALL SURFACES OF SHELL MUST BE PARALLEL TO PLANE PLY WITHIN 0.05" P.P.T.
5. PRECISION MASTER FOR CONTOUR PRECISION MASTER FOR CONTOUR PRECISION MASTER FOR CONTOUR ALL PROTECTIVE SURFACES ARE TO BE PROTECTED WITH DELAPLEX AND REPAIRS AROUND LONGITUDINAL
6. SURFACE SA MUST BE SQUARE WITH PLANE PLY WITHIN 0.05" P.P.T.
7. SURFACE SA MUST BE PARALLEL TO PLANE PLS / PLB WITHIN 0.05" P.P.T. RESPECTIVELY AS SHOWN
8. MATERIAL - BINDER LAMINATE RESIN (ML-3500A TYPE 2) LAMINATE - GLASS FIBER NO. 15 (UL-7) SHELL TYPE 2
9. THE FOLLOWING PROPERTIES ARE REQUIRED FOR PLASTIC LAMINATE COMPOSITE DENSITY - 0.80 LB/IN<sup>3</sup> MAX. TENSILE MOD OF ELASTICITY - 5 X 10<sup>6</sup> PSI MIN. TENSILE BULK STRENGTH - 12,000 PSI MIN. PLY TENSILE STRENGTH - 45,000 PSI MIN. TENSILE STRENGTH - 40,000 PSI MIN. MEASURED IN THE DIRECTION OF SHEAR & PULL ON PLAT PANELS
10. MOLDING - VACUUM BAG
11. ALL CONNECTING CURVED SURFACES OR CURVED AND STRAIGHT SURFACES SHOWN AS THIN MUST BE SMOOTHLY
12. BREAK SHARP EDGES 0.05" OR MORE OR CHANGE UNLESS OTHERWISE SPECIFIED
13. THIS SYMBOL (O) INDICATES NOTES AND DIMENSIONS OF PRIMARY IMPORTANCE
14. INDIVIDUAL TOLERANCES ARE NOT ACCUMULATIVE WHEN LOCATING WITH RESPECT TO TRUE POSITION
15. DIMENSIONS WITHOUT TOLERANCE ARE BASIC AND DEFINE TRUE POSITION AND/OR TRUE CONTOUR
16. TRUE POSITION IS THE EXACT LOCATION OF A POINT
17. SEE (SEE FIG. 100) FOR INTERPRETATION OF DRAWING

UNITS ASSOCIATED WITH ASSEMBLY 40-100-157

REVISION	DATE	BY	CHK	DESCRIPTION
1				ISSUED FOR CONSTRUCTION
2				RETRACED WITH 4874 ENL. PER 01-10-48-100

Front Frame LF-2.

C

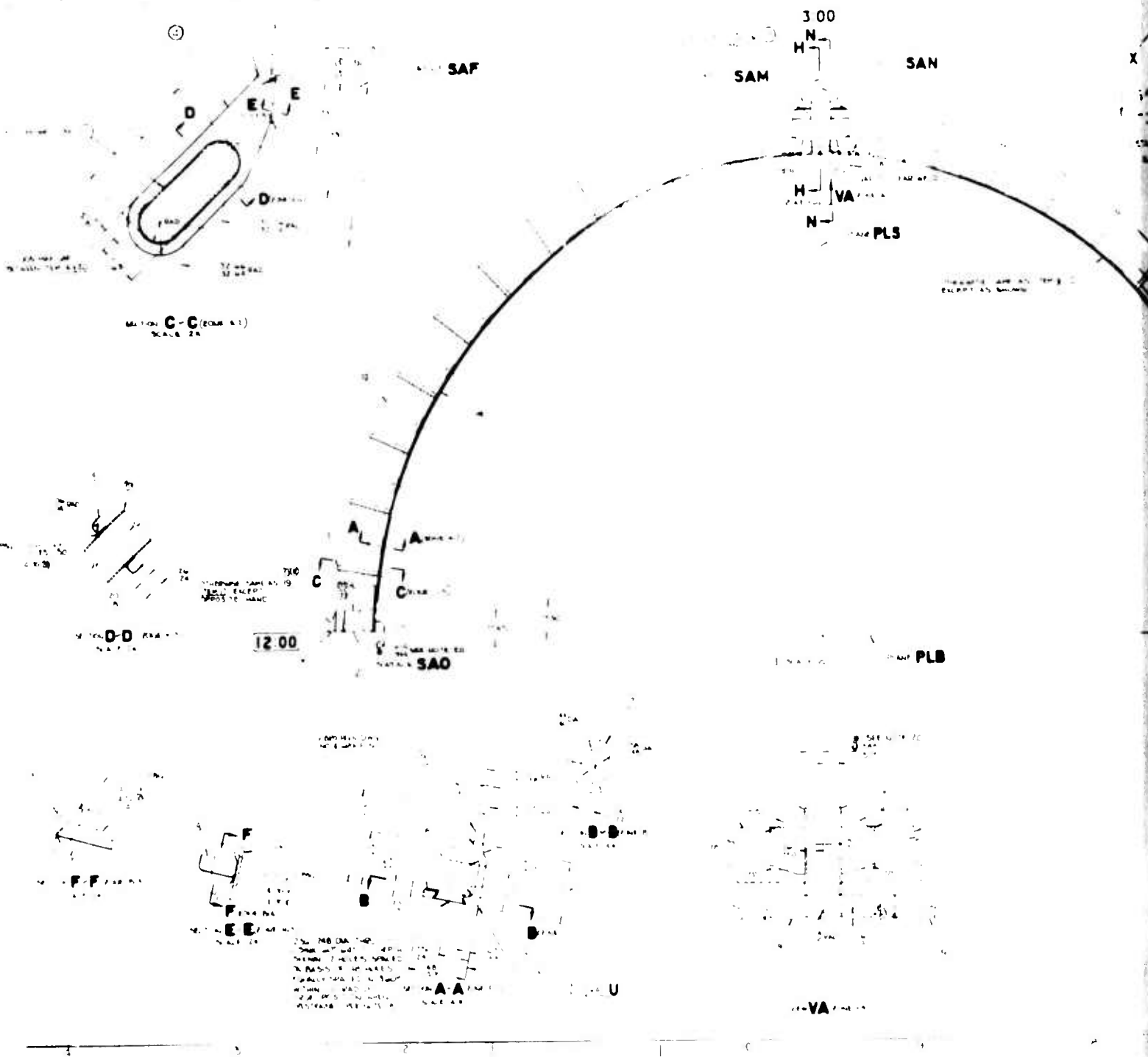
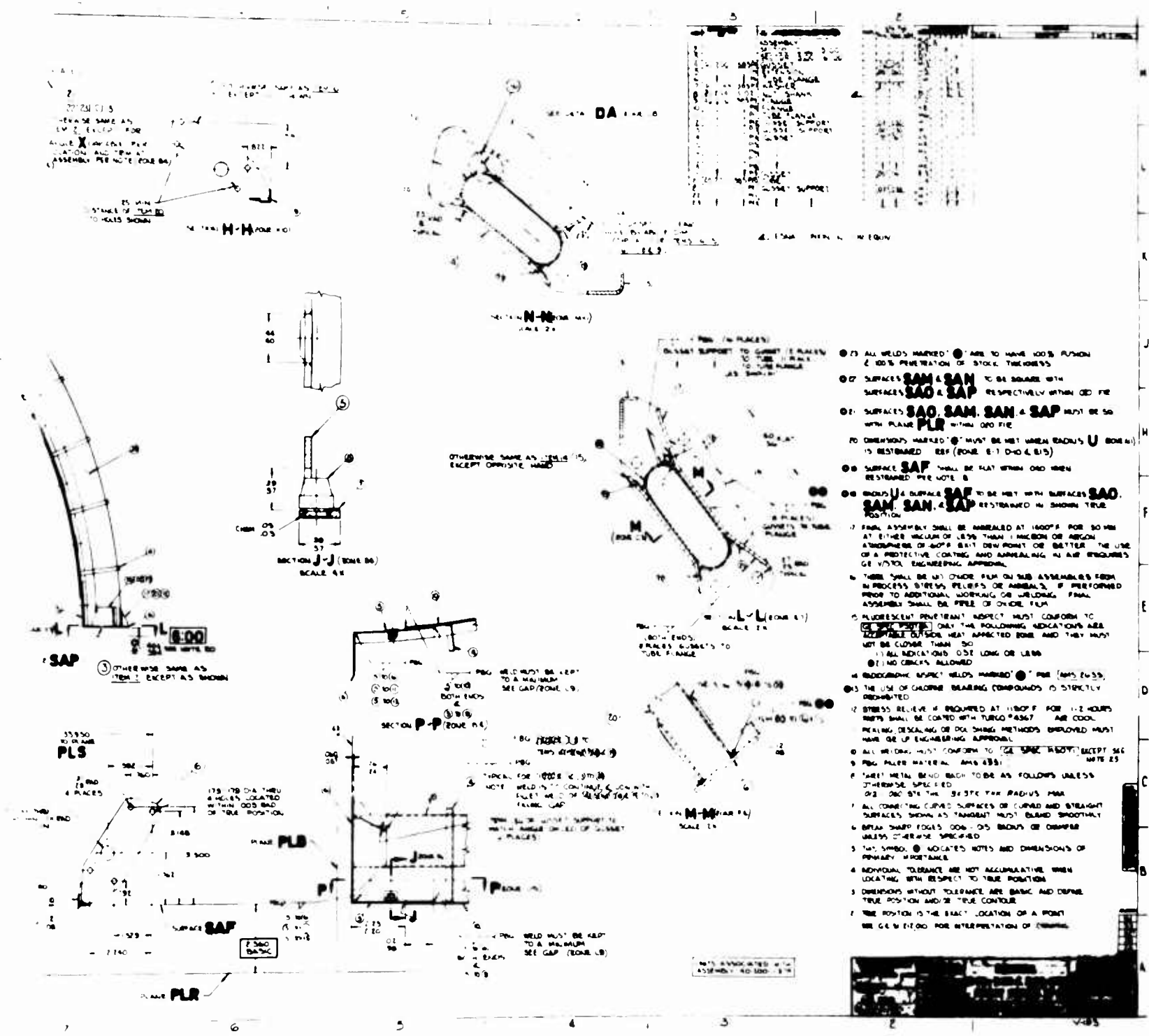


Figure 10. Draw 3 to

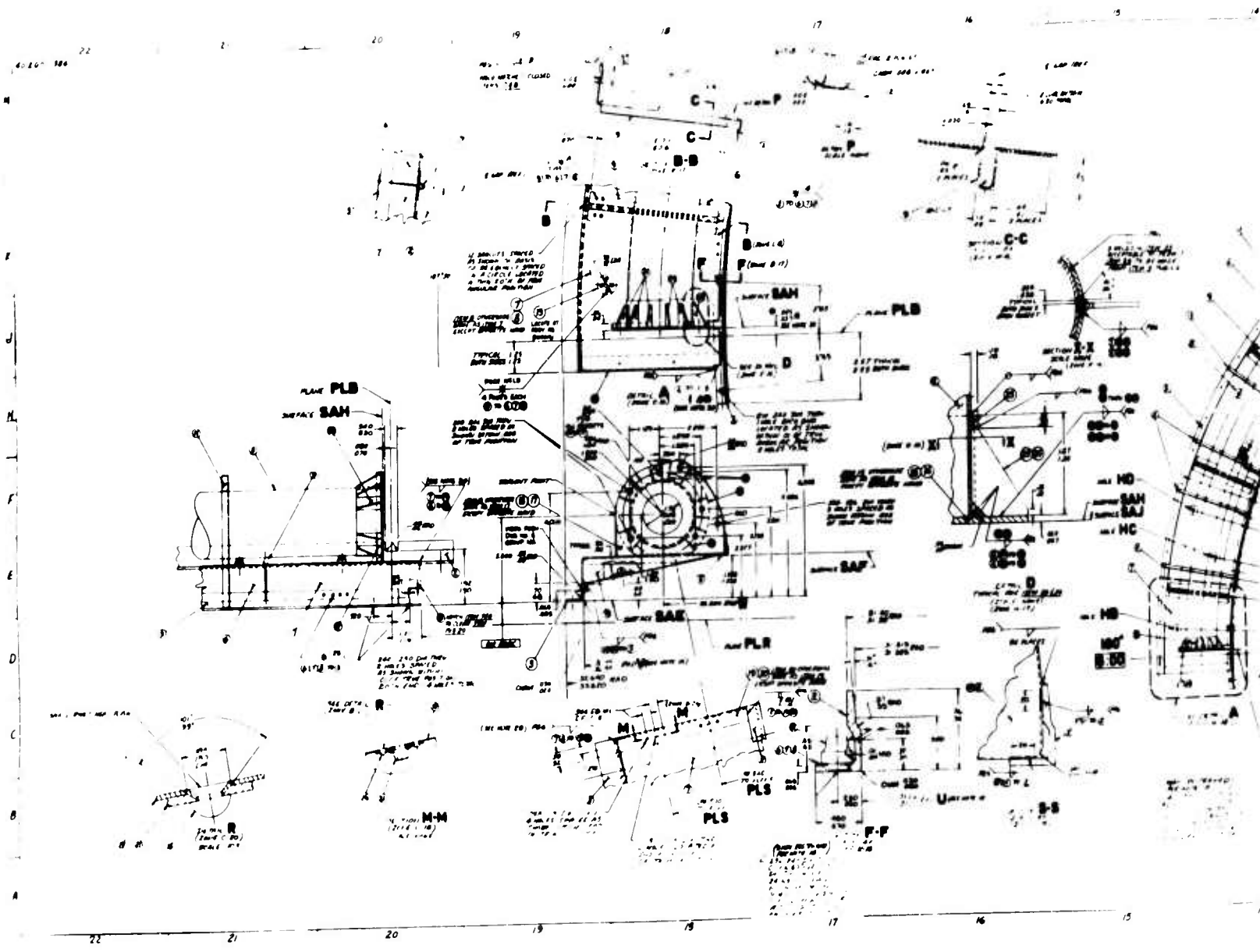




- 17 ALL WELDS MARKED '●' ARE TO HAVE 100% FUSION & 100% PENETRATION OF STOCK THROUGHS.
- 18 SURFACES **SAM** & **SAN** TO BE SQUARE WITH SURFACES **SAO** & **SAP** RESPECTIVELY WITHIN GD FIE
- 19 SURFACES **SAO**, **SAM**, **SAN** & **SAP** MUST BE SQ WITH PLANE **PLR** WITHIN GD FIE
- 20 DIMENSIONS MARKED '○' MUST BE MET UNLESS RADII'S U (ZONE M) IS RESTRAINED. SEE (ZONE E-1) D-10 & E-15)
- 21 SURFACE **SAP** SHALL BE FLAT WITHIN GD WHEN RESTRAINED PER NOTE 8
- 22 END OF 'A' SURFACE **SAP** TO BE MET WITH SURFACES **SAO**, **SAM**, **SAN**, & **SAP** RESTRAINED IN SHOWN TRUE POSITION
- 23 FINAL ASSEMBLY SHALL BE ANNEALED AT 1100°F FOR 20 HRS AT EITHER VACUUM OR LESS THAN 1 ATMOSPHERE OR ARGON ATMOSPHERE OF GD P. EXIT DOW POINT OR BETTER. THE USE OF A PROTECTIVE COATING AND ANNEALING IN AIR REQUIRES GE VENDOR ENGINEERING APPROVAL.
- 24 THERE SHALL BE NO OXIDE FILM ON THIS ASSEMBLY FROM IN PROCESS STRESS RELIEFS OR ANNEALS. IF PERFORMED PRIOR TO ADDITIONAL WORKING OR WELDING, FINAL ASSEMBLY SHALL BE FREE OF OXIDE FILM.
- 25 FLUORESCENT PENETRANT INSPECT MUST CONFORM TO (SEE SPEC. PART 1) ONLY THE FOLLOWING INDICATIONS ARE ACCEPTABLE OUTSIDE HEAT AFFECTED ZONE AND THEY MUST NOT BE CLOSER THAN 50 MIL TO INDICATIONS 0.52 LONG OR LESS. (SEE NOTE 10) NO CORRECTION ALLOWED.
- 26 INDICATIONS AFFECT WELDS MARKED '●' PER (AMS 4353).
- 27 THE USE OF GLOBE BEARING (COMPOUNDS) IS STRICTLY DISHABITED.
- 28 STRESS RELIEF IS REQUIRED AT 1100°F FOR 12 HOURS. PARTS SHALL BE COATED WITH TURCO 4367 AIR COOL. WELDING, DEGRADING OR OXIDIZING METHODS EMPLOYED MUST HAVE GE UP ENGINEERING APPROVAL.
- 29 ALL WELDS MUST CONFORM TO (SEE SPEC. PART 1) EXCEPT SEE NOTE 25
- 30 PIG PLEER MATERIAL AMS 4351
- 31 SHEET METAL BEND EACH TO BE AS FOLLOWS UNLESS OTHERWISE SPECIFIED:  
 0.125 DIA OR THE BEST FOR RADIUS MAX
- 32 ALL CURVED SURFACES OF CURVED AND STRAIGHT SURFACES SHOWN AS TANGENT MUST BE BLENDED SMOOTHLY
- 33 BREAK SHARP EDGES 0.005 DIA RADIUS OR OTHERWISE UNLESS OTHERWISE SPECIFIED
- 34 THE SYMBOL '○' INDICATES NOTES AND DIMENSIONS OF PRIMARY IMPORTANCE
- 35 INDIVIDUAL TOLERANCE ARE NOT ACCUMULATIVE WHEN LOCATING WITH RESPECT TO TRUE POSITION
- 36 DIMENSIONS WITHOUT TOLERANCE ARE BASIC AND DEFINE TRUE POSITION AND/OR TRUE CONTROL
- 37 THE POSITION IS THE EXACT LOCATION OF A POINT SEE GE M F1000 FOR INTERPRETATION OF FINISHING

12001-385, Sector 12 to 3 and lock, Front Frame LF-2

C



**A**

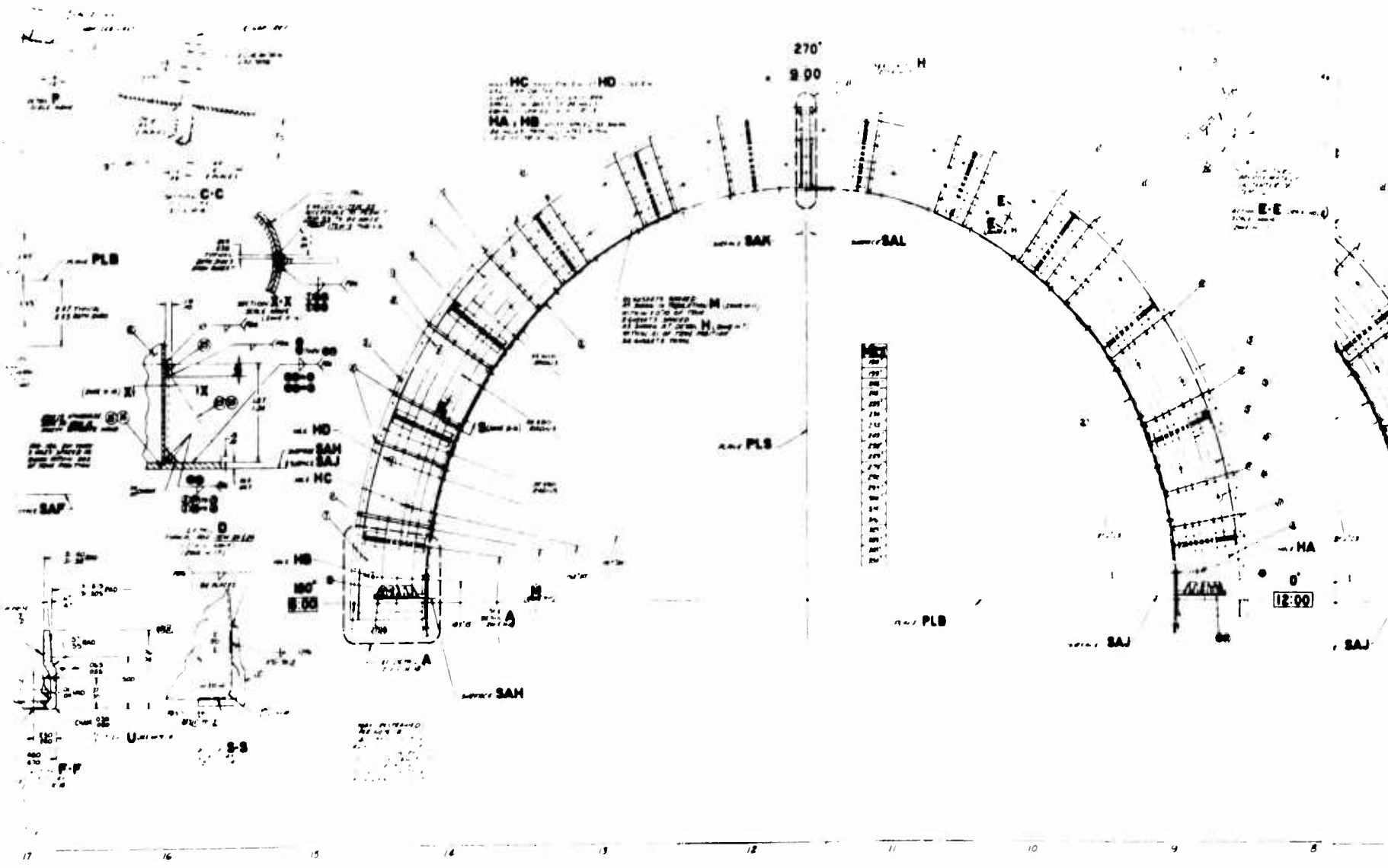


Figure 11. Drawing 4012001-384, Sector 6 to 12 o'clock  
Front Frame LF-2.

12 o

**B**



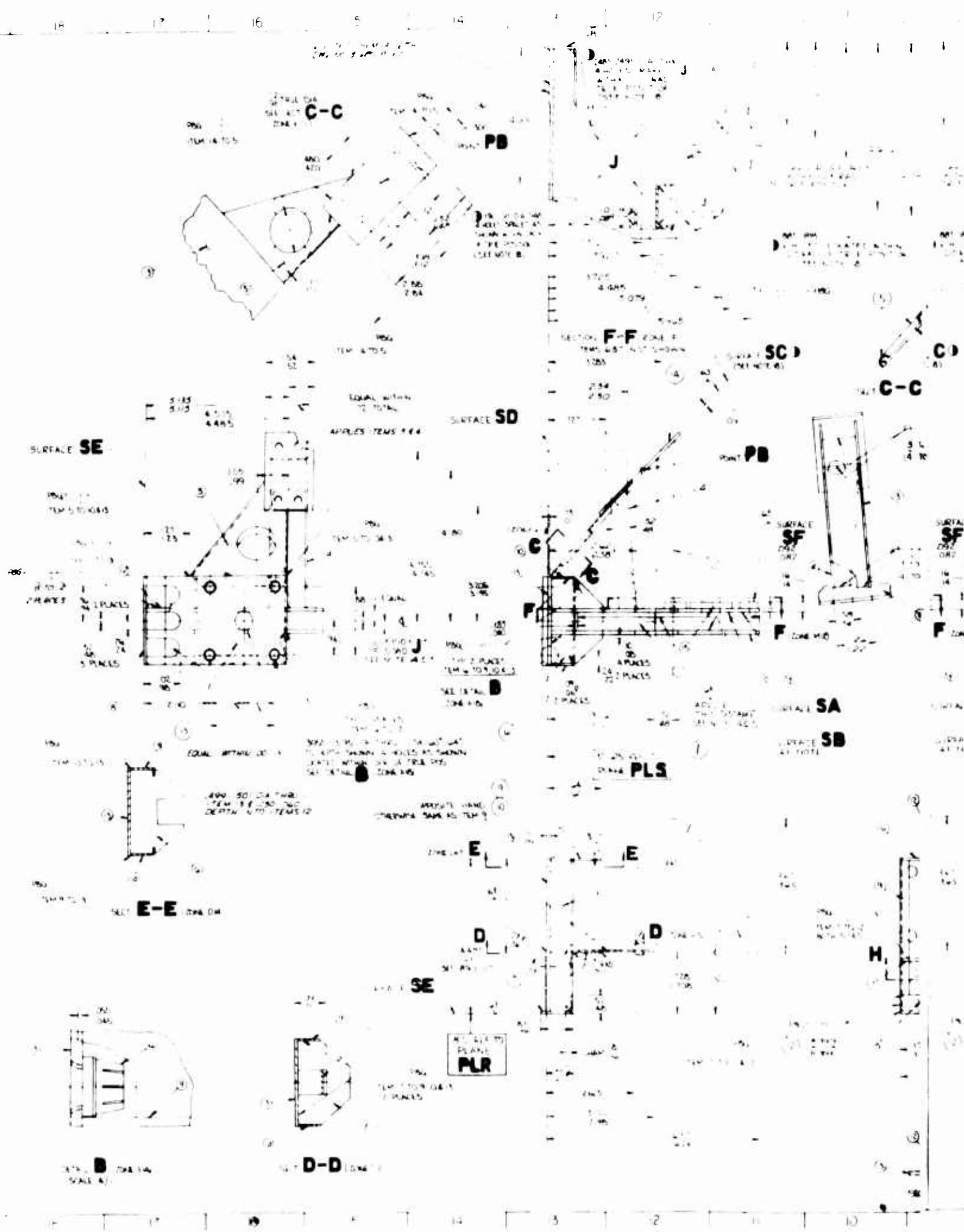
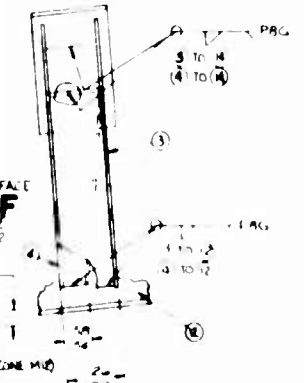
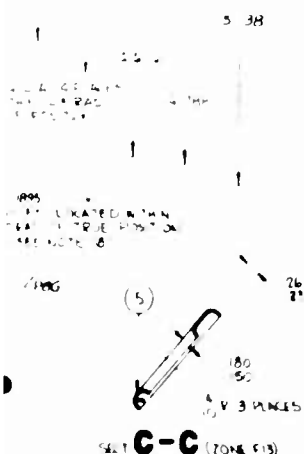


Figure 12. Drawing 4012001-382, En 1200  
Struts Front Frame LF-2, mt F

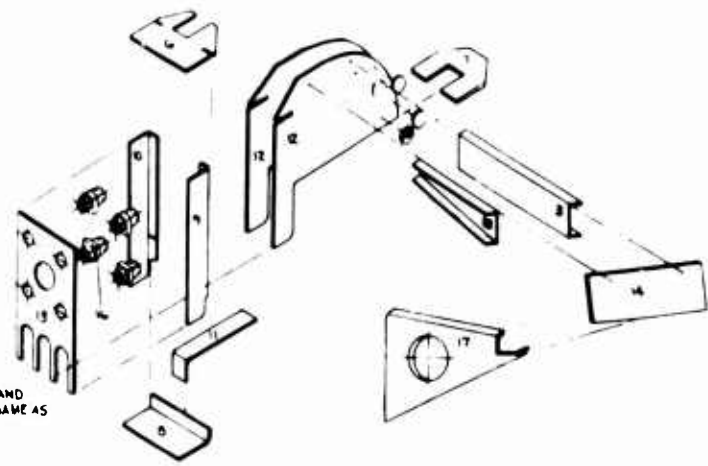
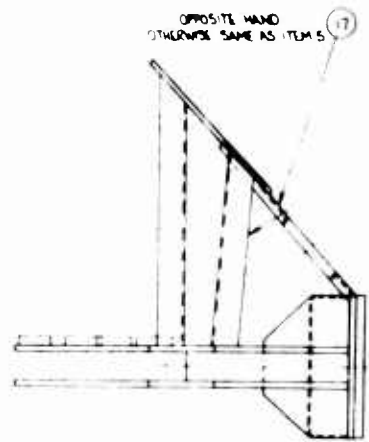
A

ITEM	DESCRIPTION OF PART	QTY	GROUP NO. & QTY	REVISIONS
1	CHANNEL	1	1	
2	CHANNEL (TAPERED)	1	1	
3	BRACKET	1	1	
4	STIFFENER	1	1	
5	FLANGE	1	1	
6	STIFFENER	1	1	
7	FACE PLATE	1	1	
8	FACE PLATE	1	1	
9	MOUNTING PLATE	1	1	
10	BOSS	1	1	
11	SHANK NUT	1	1	
12	SHANK	1	1	
13	CHANNEL (TAPERED)	1	1	

▲ (SMA UNION N.J. OR EQUIV)  
 ● ALL ITEMS S. IDENT. CALL. PRIOR TO FINAL MACHINING

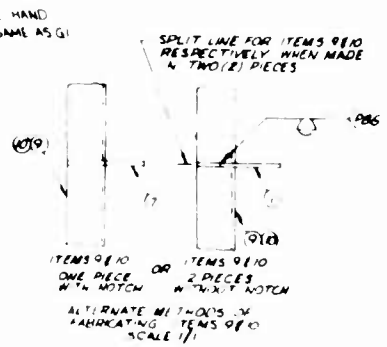
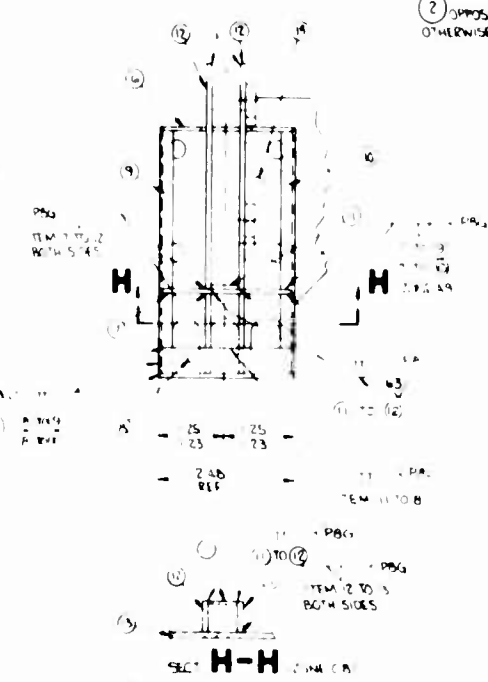


FACE SA  
 FACE SB



SCHEMATIC EXPLODED VIEW OF GROUP 2

- ① THIS SYMBOL (1) INDICATES HOLES & SURFACES TO BE MACHINED AT ASSEMBLY. REF ASSEMBLY DWG NO ZONE AS SEE NOTE 4 ON ASSEMBLY DWG.
- ② SUPP SD & SE TO BE SQUARE WITH SURF SA & SURF SD TO BE SQUARE TO SURF SE WITHIN .001" IN.
- ③ DIM FOR SURF SC, SD, SE & SF ARE TO BE MET WITH SURF SA & SB IN THE RESTRAINED CONDITION PER NOTE 15.
- ④ "J" DIM TO BE MET FOR LENGTH SHOWN WHEN SURF SA & SB ARE RESTRAINED USING A SOB-B10 THE RESTRAINING PLATE (ROUTE F13).
- ⑤ SURF SA & SB ARE TO BE FLAT WITHIN .002" IN IN THE RESTRAINED STATE FOR FINISHED LENGTH SHOWN.
- 15 ALL COMPONENT PARTS SHALL BE FLUORESCENT PENETRANT INSPECTED PER (SEE SPEC P5070) (CLASS A OR B) PRIOR TO WELDING. NO CRACKS ALLOWED.
- 12 FINAL ASSEMBLY SHALL BE AGED AT APPROX 100°F FOR 1 HOUR. AIR COOLED. HARDNESS OF R 95-103 MUST BE MET.
- 11 FINAL ASSEMBLY SHALL BE ANNEALED PER NOTE 10 PRIOR TO FINAL ASSEMBLY AGE.
- 10 A PROCESS ANNEALS IF REQUIRED SHALL BE PERFORMED IN A HYDROGEN OR ARGON ATMOSPHERE OF 100°F OR BETTER FOR 30 MINUTES AT ROOM TEMP. RAPID AIR COOL.
- 9 WELDING SHALL BE PERFORMED ON MATERIAL IN THE SOLUTIONED ANNEALED CONDITION.
- 8 MATERIAL USED FOR FABRICATION SHALL BE HEAT TREATED & TENSILE TESTED PER LATEST REV. OF (SEE SPEC P5070) RESULTS SHALL MEET LATEST REV. OF (SEE SPEC P5070) MINIMUMS.
- ⑦ ALL WELDS TO HAVE 100 PER CENT FUSION & 100 PER CENT PENETRATION OF STOCK THICKNESS.
- 6 FUSION WELDS TO BE RADIOGRAPHICALLY INSPECTED PER (SEE SPEC P5070) PRIOR TO HEAT TREATING. CRACKS PROXIMITY TO WELDS INCLUDING CRACKS OF PENETRATION SHALL BE CAUSE FOR REJECT.
- 5 ALL WELDS TO BE FLUORESCENT PENETRANT INSPECTED PER (SEE SPEC P5070) CLASS A OR B. NO CRACKS ALLOWED.
- 4 ALL WELDING MUST CONFORM TO (SEE SPEC P5070) REQUIREMENTS UNLESS OTHERWISE SPECIFIED IN (SEE SPEC P5070).
- ③ 3. FILLER METL. (ANVCO) 1/4" WELDING WIRE.
- 2 THIS SYMBOL (2) INDICATES NOTES & DIMENSIONS OF PRIMARY IMPORTANCE.
- 1 SEE (SEE SPEC P5070) FOR INTERPRETATION OF DIMS.



1. INDICATED WITH 4. 2. 3. 4. 5. 6. 7. 8. 9. 10. 11. 12. 13. 14. 15. 16. 17. 18.

<p>END CAPS          12:00-6:00 O'CLOCK          STRUTS          FRONT FRAME LF-2</p>	<p>REVISIONS</p>
---	------------------

B

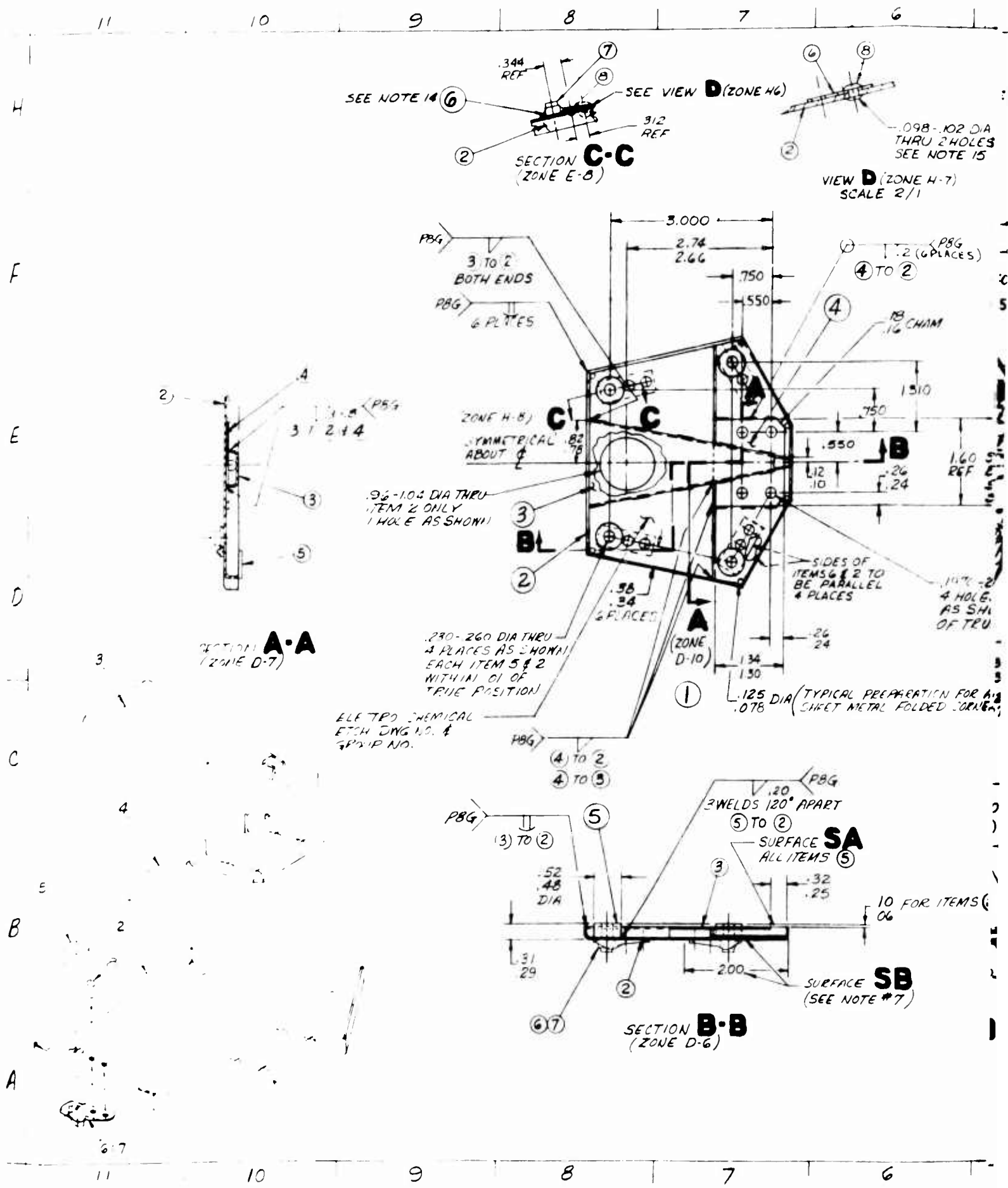


Figure 13. Drawing 4012001-3873

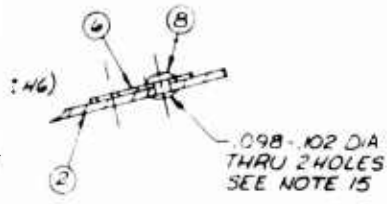
A

ITEM	IDENTIFICATION NO	DESCRIPTION OR NAME	MTRL	ZONE	GROUP NO & QTY				REVISIONS	
					1	2	3	4	DATE	APPROVAL
1		ASSEMBLY		C-7	1					
2	4012001-387P2	BASE		D-8	1					
3	P3	STIFFENER		D-8	1					
4	P4	DOUBLER		F-6	2					
5	P5	BOSS		C-8	4					
6	13710-02	FLOATING ANCHOR NUT		H-9	4					
7	1325-B-02	REPLACEMENT NUT		H-8	4					
8	AN125421	RIVET		H-8	8					

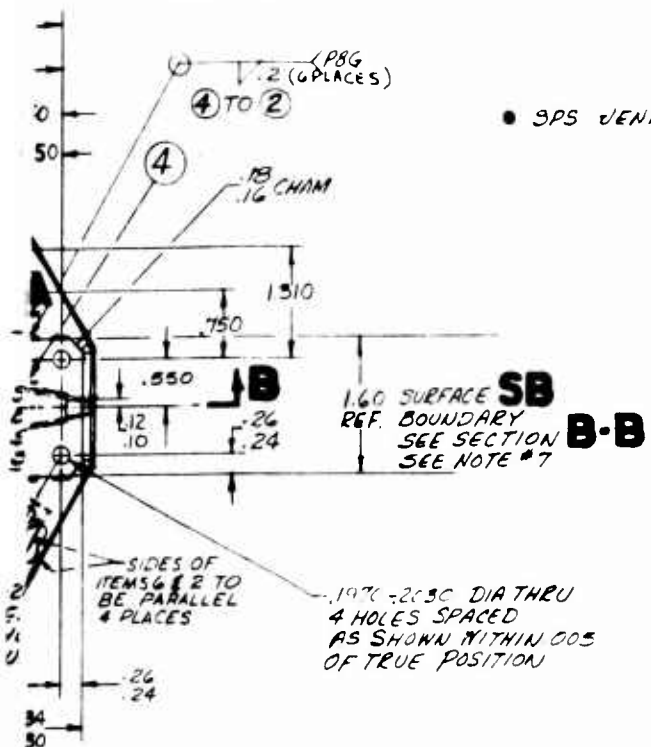
REVISIONS

1	GEN CHG PERM RECORD REPRODUCIBLE FILED PA 001-387-1	DATE	APPROVAL

1 STK THK .027-.030



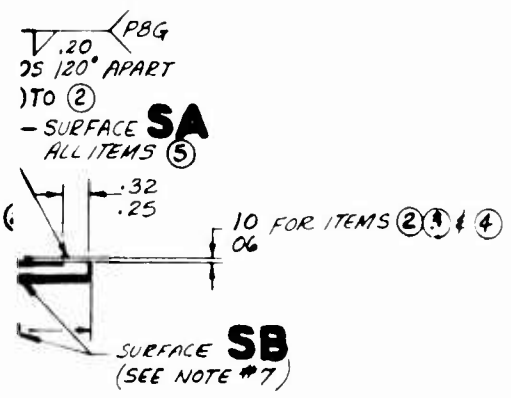
VIEW D (ZONE H-7)  
SCALE 2/1



• SPS JENKINTOWN, PENN'A. OR EQUIV.

- 15. RIVET HOLES IN ASSEMBLED PARTS MUST MATCH SO THAT RIVETS CAN BE INSERTED WITHOUT FORCING
- 14. RIVET PER [GE SPEC P207E1] (RIVETS)
  - A) NUT HOLE IN ITEM 6 TO BE LOCATED CONCENTRIC WITH HOLE IN ITEM 2 WITHIN .010 OF TRUE POS
  - B) NUT NOT TO BE ASSEMBLED UNTIL AFTER HEAT TREAT PER NOTE 12
- 13. THE USE OF CHLORINE BEARING COMPOUNDS IS STRICTLY PROHIBITED
- 12. STRESS RELIEVE IF REQUIRED AT 1150°F FOR 1 TO 2 HRS PARTS SHALL BE COATED WITH TURCO #4367 AIR COOL
- 11. BEND RADIUS FOR .030 STK MATL TO BE .030 ± .20 EAD
- 10. ALL WELDS TO BE FLUOROSCOPIC PENETRANT INSPECTED PER [GE P507B] NO SPACER ALLOWED
- 9. ALL WELDING MUST CONFORM TO [GE SPEC M007I]
- 8. P8G FILLER MATERIAL [AMS 4951]
- 7. WITH SURF. SB RESTRAINED, SURF. SA MUST BE PARALLEL WITHIN .002 TOTAL
- 6. BREAK SHARP EDGES .006-.015 RADIUS OR CHAMFER UNLESS OTHERWISE SPECIFIED
- 5. THIS SYMBOL (⊙) INDICATES NOTES & DIMENSIONS OF PRIMARY IMPORTANCE
- 4. INDIVIDUAL TOLERANCES ARE NOT ACCUMULATIVE WHEN LOCATING WITH RESPECT TO TRUE POSITION
- 3. DIMENSIONS WITHOUT TOLERANCE ARE BASIC & DEFINE THE POSITION AND/OR TRUE CONTOUR
- 2. TRUE POSITION IS THE EXACT LOCATION OF A POINT
- 1. SEE [SI-212,010] FOR INTERPRETATION OF DNG

1/25 DIA (TYPICAL PREPARATION FOR ALL SHEET METAL FOLDED CORNERS)



UNLESS OTHERWISE SPECIFIED DIMENSIONS ARE IN INCHES TOLERANCES ON FRACTIONS DECIMALS ANGLES	DATE: 1/19/53 APPROVED: [Signature] ENGR: [Signature] MFG: [Signature] MATERIAL: [Signature]	<b>BRACKET FRONT FRAME LF-2</b>	GENERAL ELECTRIC EPID EYENDALE OHIO
MATERIAL 1) AN 101 2) AMS 4951	SCALE: FULL	WT: 276 LBS MAX	CONT ON SHEET SH NO

D 4012001-387

161  
53  
38  
24

173. Drawing 4012001-387, Bracket Front Frame LF-2.

**B**

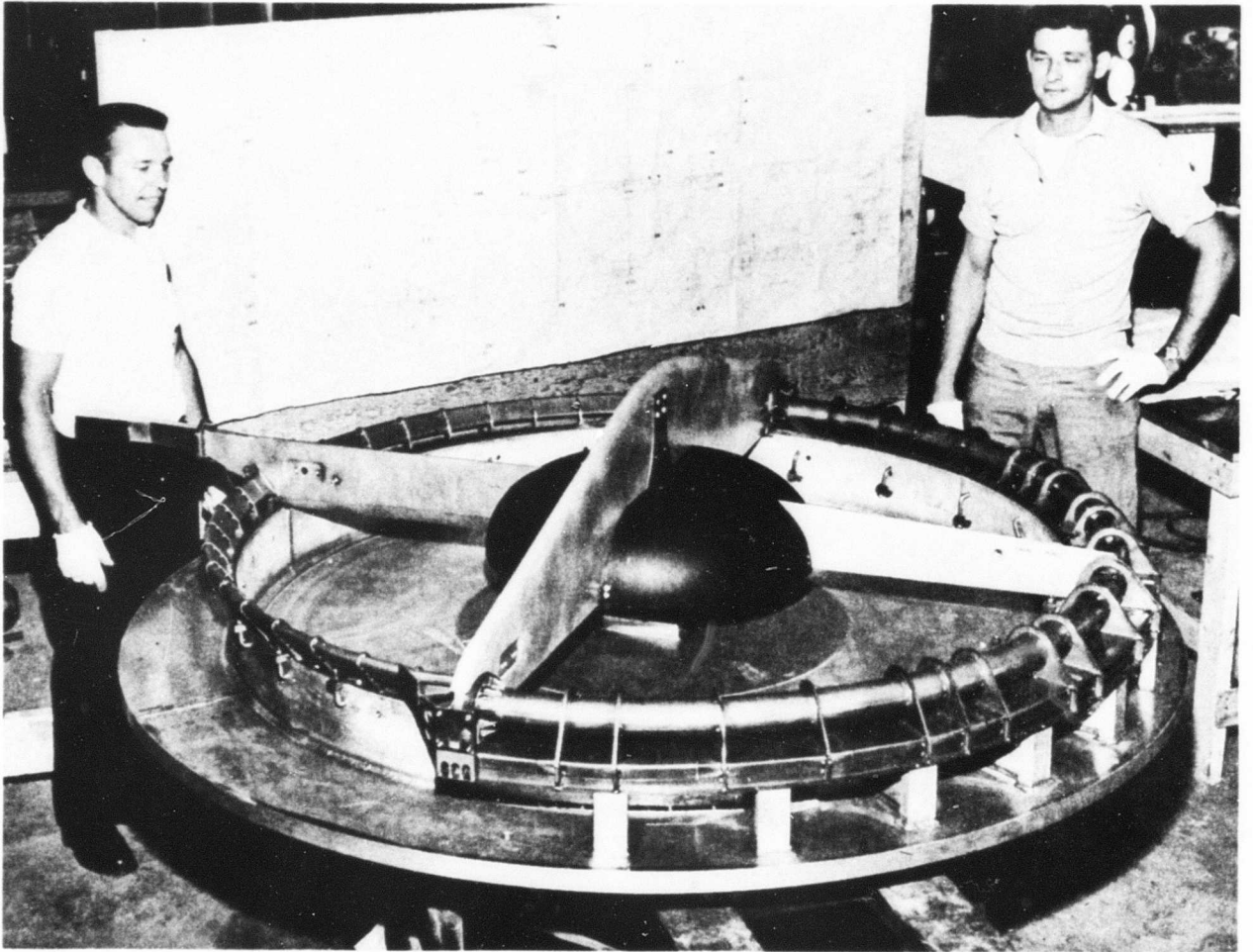
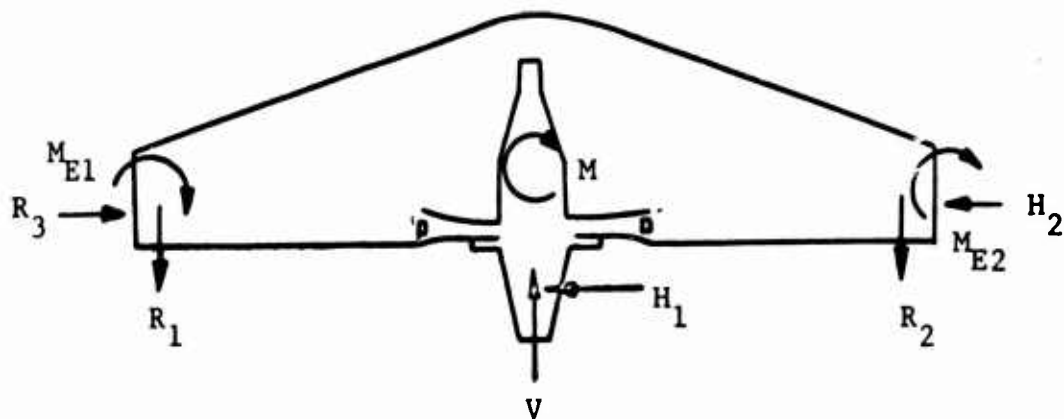
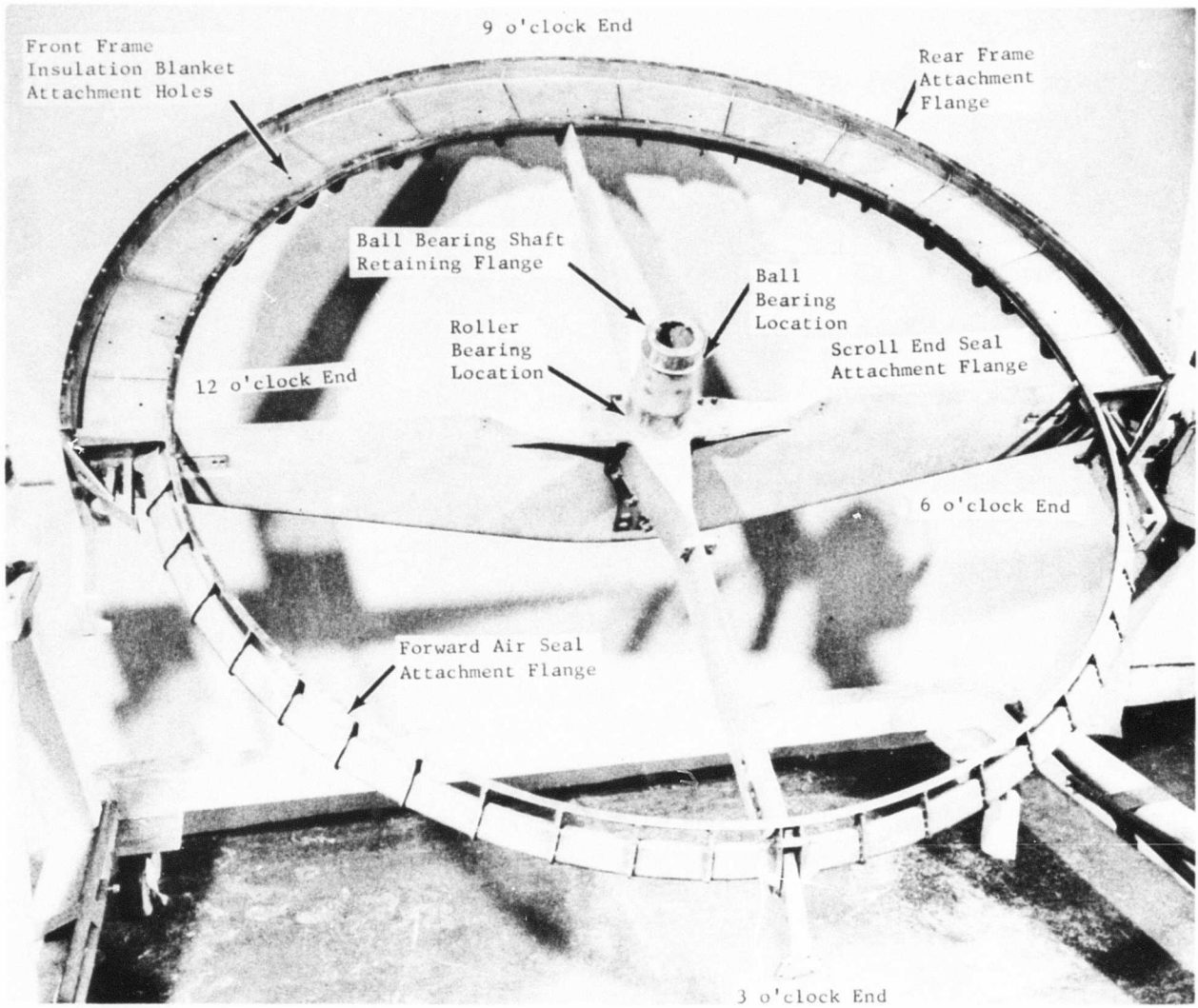


Figure 14. LF-2 Front Frame View Showing Completed Frame and Assembly Tooling at the Manufacturing Source. The Machined Test, 3 O'clock A286 Support Beam is Shown Attached to the 3 O'clock Strut End.

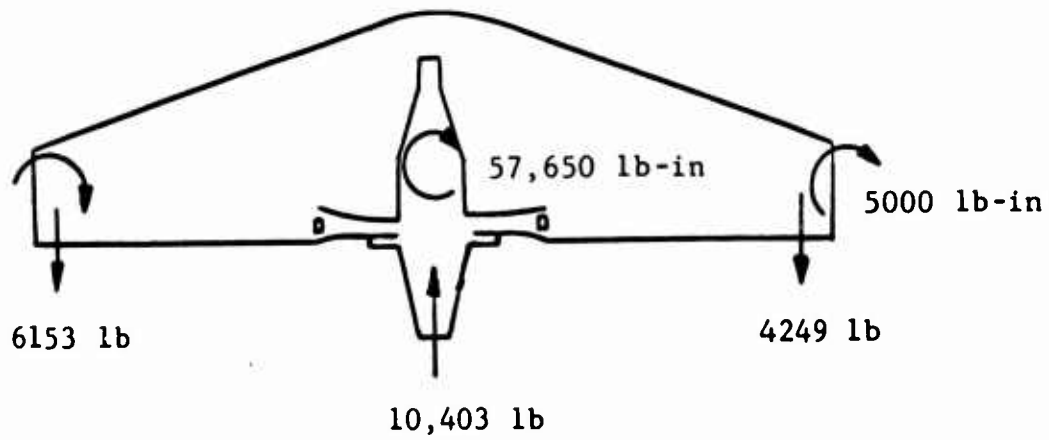


<u>Load</u>	<u>Definition</u>	<u>Total</u>
V	Rotor Lift - 5200 lb 2 Rad/Sec Gyro Reaction of Minor Strut - 5000 lb Rotor lg Upload - 203 lb	10,403 lb
M	Crossflow - 30,000 lb-in Partial and Induced - 17,500 lb-in Rotor 5g's Induced - 10,150 lb-in	57,650 lb-in
H <sub>1</sub>	Partial Admission - 1750 lb 5 g's Side - 1015 lb	2,765 lb
H <sub>2</sub>	Exit Louver In-plane Loading	2,000 lb
M <sub>E1</sub> - M <sub>E2</sub>	Exit Louver Load Induced Moment	5,000 lb-in
R <sub>1</sub>	Reaction	5,733 lb
R <sub>2</sub>	Reaction	4,669 lb
R <sub>3</sub>	Reaction	4,765 lb

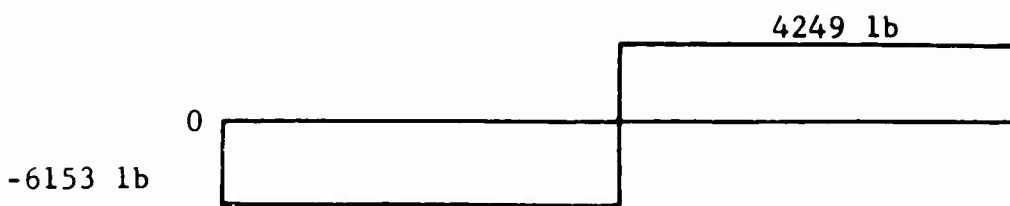
Figure 16. Worst Loading Condition of Major Strut with Gyro Reacted by the 3 O'clock Strut.



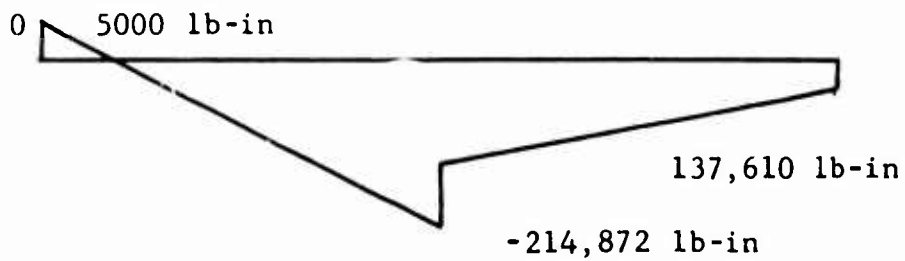
**Figure 15.** LF-2 Front Frame View Showing Frame in Inverted Position.



a) Load Diagram



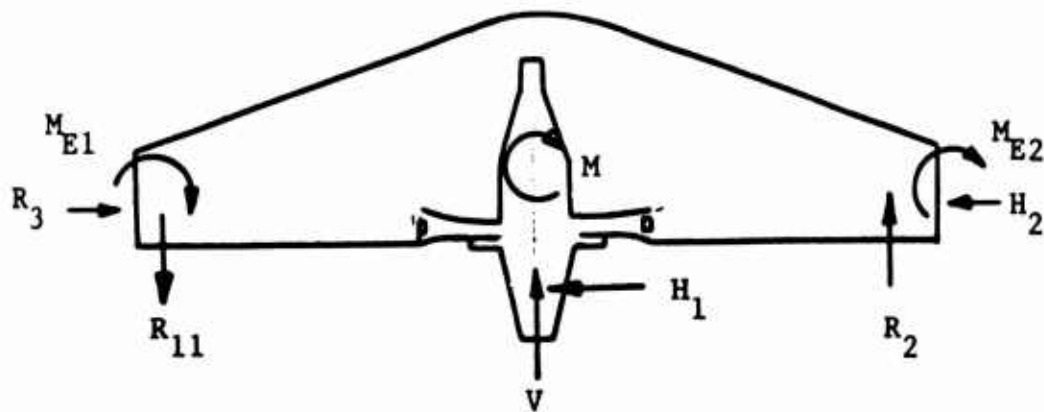
b) Shear Diagram



c) Bending Moment Diagram

Figure 17. Shear and Bending Moment Diagram Showing Maximum Worst Loading on Major Strut when the 2 Rad/Sec Gyro is Reacted by the 3 O'clock Strut, Reference Figure 16.

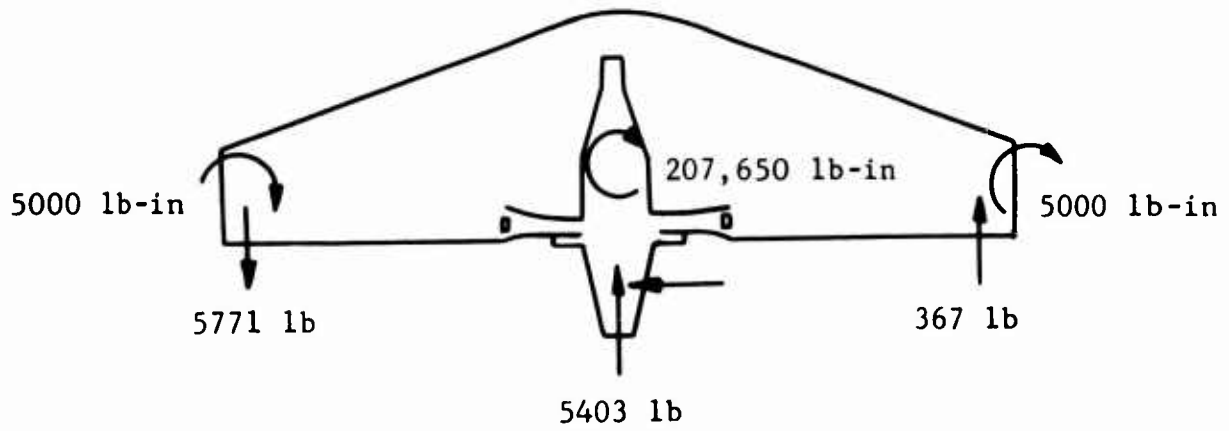
**BLANK PAGE**



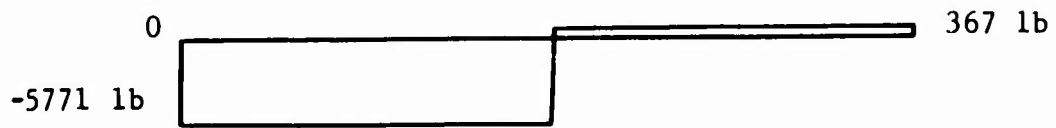
The load is the same as shown in Figure 16 except for:

<u>Load</u>	<u>Definition</u>	<u>Total</u>
V	Rotor Lift - 5200 lb Rotor 1g Upload - 203 lb	5,403 lb
M	Crossflow - 30,000 lb-in Partial Admission Induced - 17,500 lb-in Rotor 5g's Side Induced - 10,150 lb-in 1.4 Rad/Sec Gyro Reacted by Major Strut - 150,000 lb-in	207,650 lb-in

Figure 18. Worst Loading Condition of Major Strut With Gyro Reacted by the Major Strut.



a) Load Diagram



b) Shear Diagram

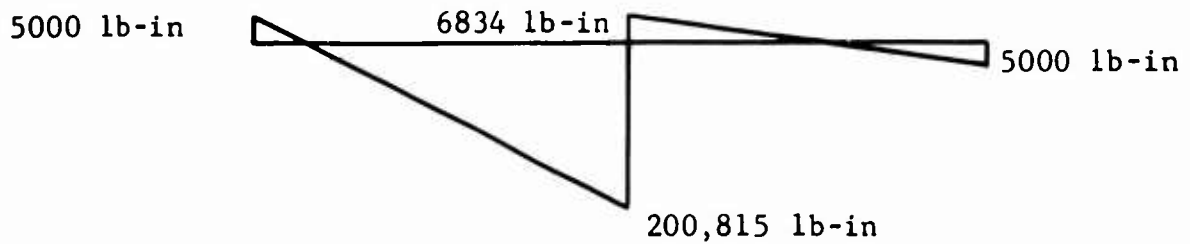
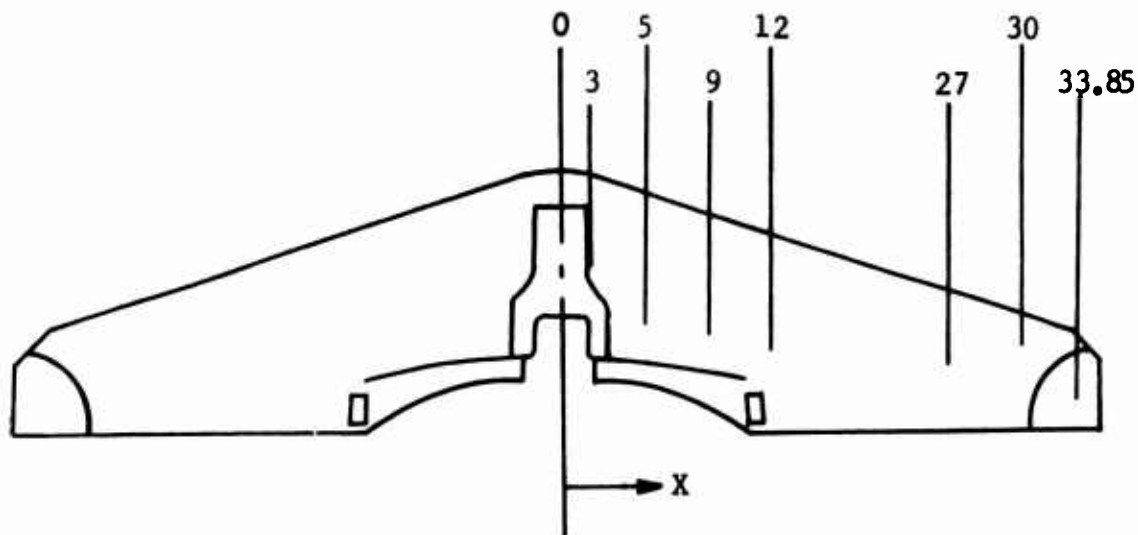


Figure 19. Shear and Bending Moment Diagram Showing Maximum Worst Loading on Major Strut When 1.4 Rad/Sec is Reacted by Major Strut, Reference Figure 18.



Sectional Properties	Location X						
	3	5	9	12	27	30	33.85
$I_{\max}$	106	100	89.2	79.2	35.2	19.6	5.1
$I_{\min}$	2.26	1.846	1.022	0.405	0.254	0.224	0.448
A	4.707	4.536	4.191	3.935	3.326	3.204	3.047
J	2.18	2.1	1.94	1.8	1.12	0.96	0.64
$C_{\max}$	6.15	6.05	5.74	5.82	3.95	3.56	2.85
$C_{\min}$	1.75	1.75	0.8	0.55	0.55	0.55	0.55

$I$  = Moment of Inertia (inch<sup>4</sup>)

$A$  = Cross Sectional Area (inch<sup>2</sup>)

$J$  = Torsional Constant =  $\frac{4A_i^2}{\int \frac{ds}{t}}$  (inch<sup>4</sup>)

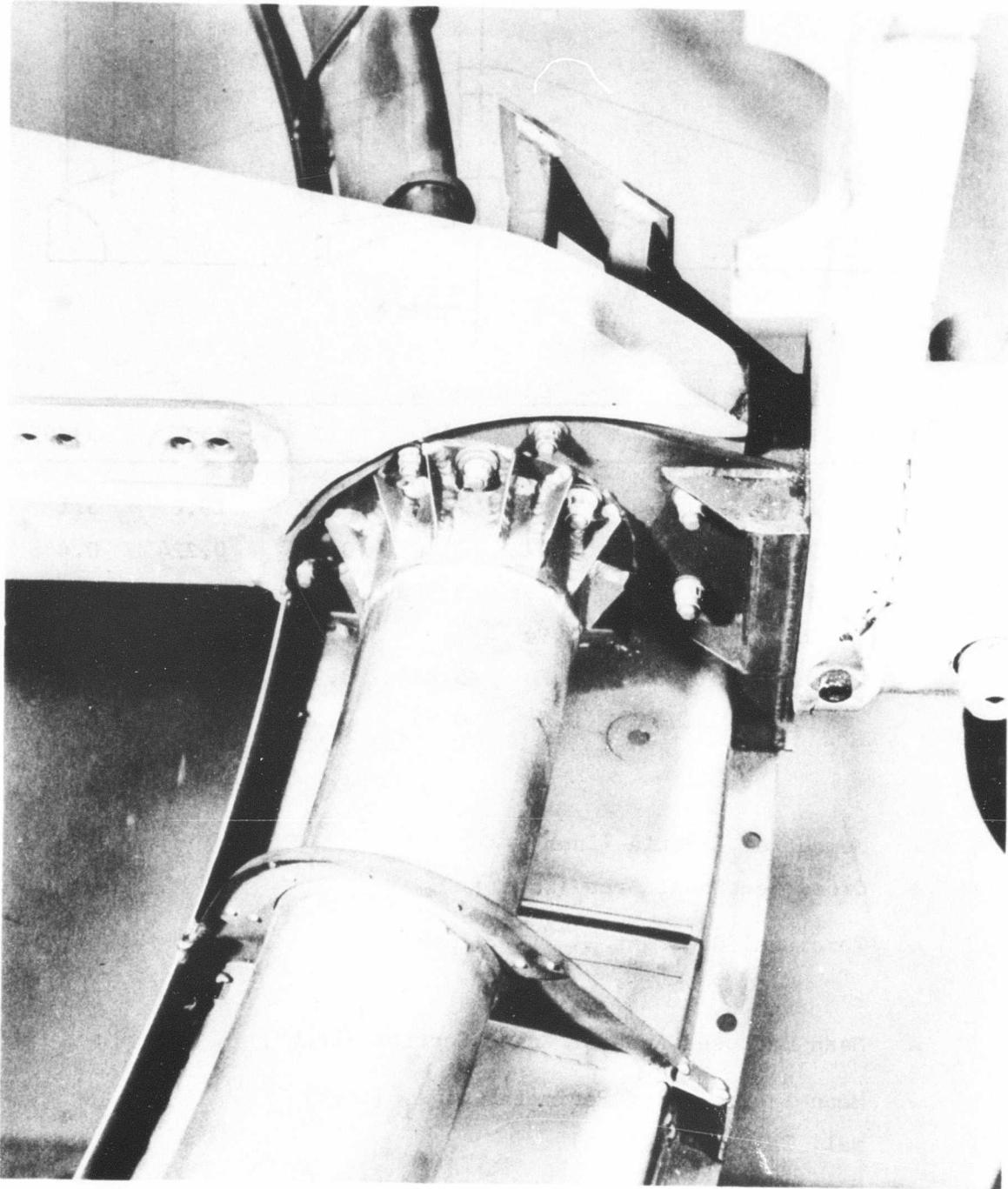
$A_i$  = Mean Enclosed Area of Cross Section (inch<sup>2</sup>)

$s$  = Mean Increment of Perimeter of  $A_i$  (inch)

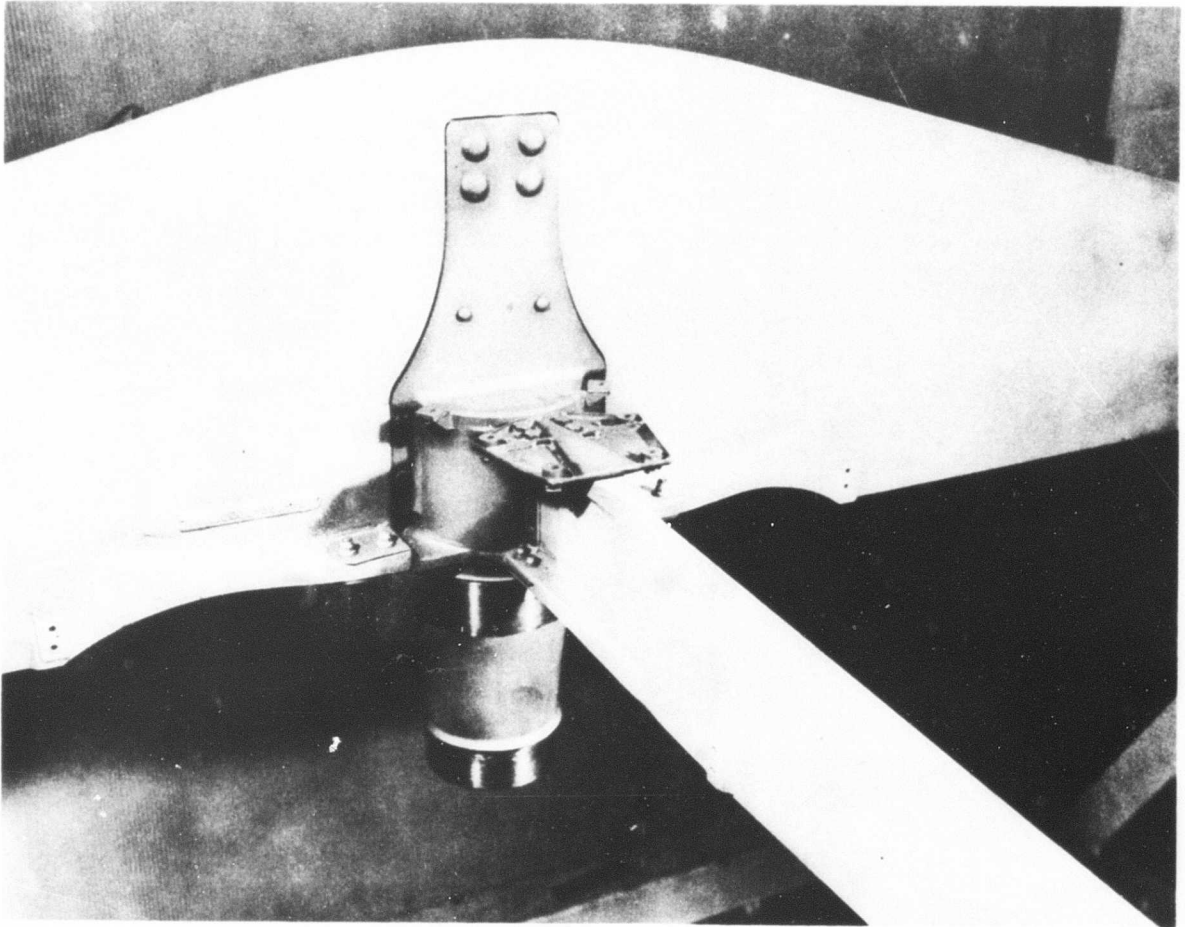
$t$  = Wall Thickness (inch)

$c$  = Distance to Extreme Fiber From Section Centroid (inch)

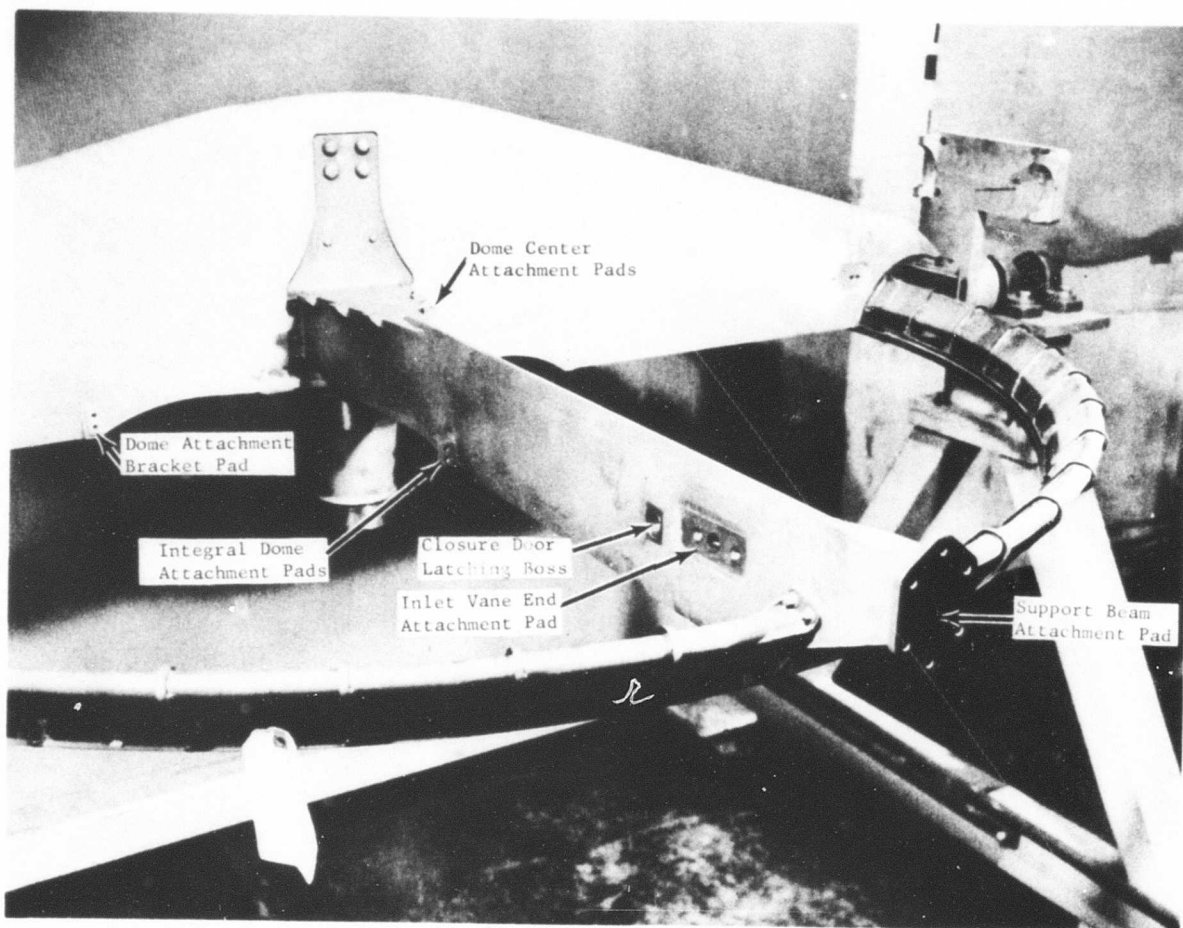
Figure 20. Sectional Properties of 12 to 6 O'clock Strut  
(Drawing 4012001-380, Figure 7).



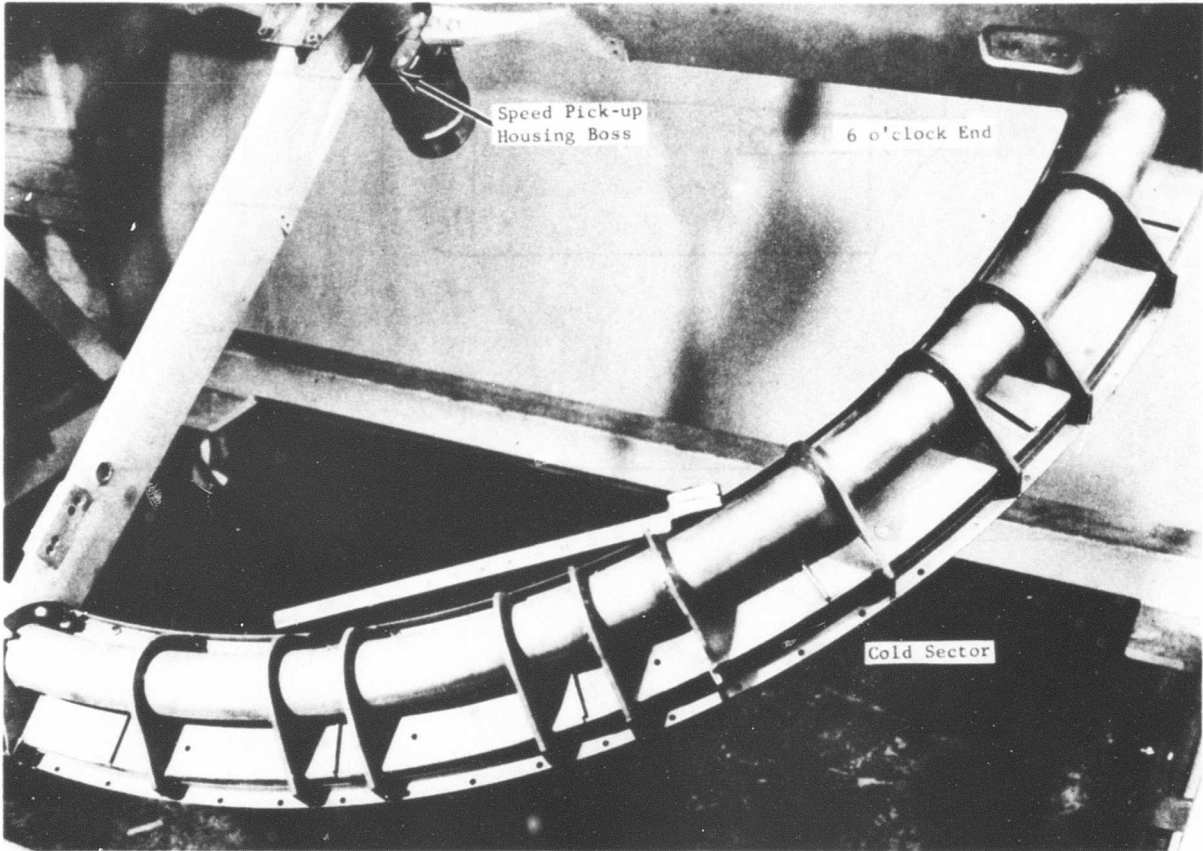
**Figure 21.** LF-2 Front Frame View Showing Attachment of the Al10AT Titanium Cold-Side Sector and 17-4 PH End Cap to the 12 to 6 O'clock Cast A356T1 Aluminum Strut.



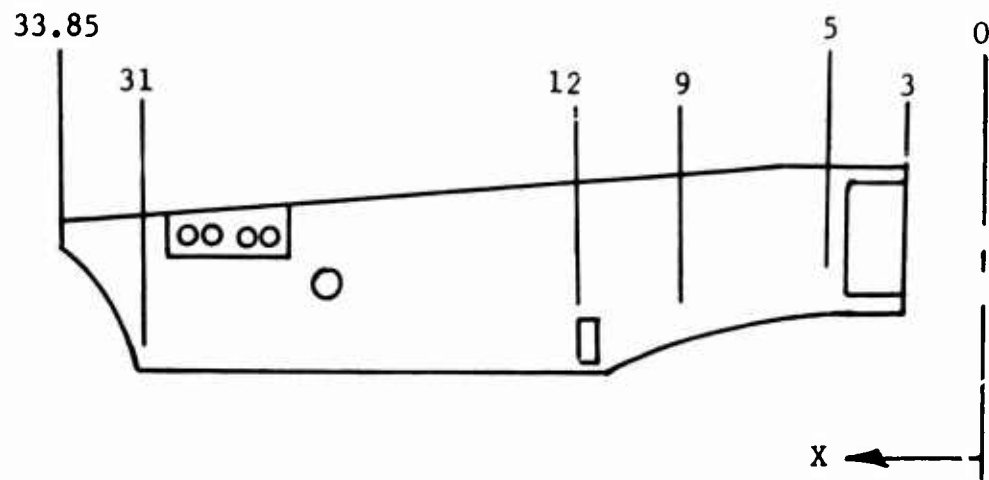
**Figure 22.** LF-2 Front Frame View Showing the Attachment of the 12 to 6 O'clock and 9 O'clock Cast A356 Aluminum Struts to the Cast 17-4 PH Hub. Also Shown is the Attachment of the 9 O'clock Dome Mounting Bracket to the 9 O'clock Strut and Hub.



**Figure 23.** LF-2 Front Frame View Showing the Cast 17-4 PH Hub With its Integral Fabricated 17-4 PH Strut; Also Shown is the Attachment of the 3 to 6 O'clock Hot-Side Sector to the 3 O'clock Strut and the 3 O'clock Strut Support Beam Attachment.

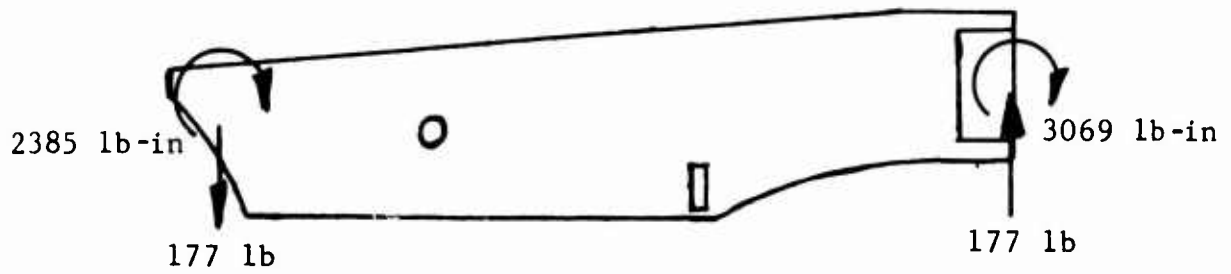


**Figure 24.** LF-2 Front Frame View Showing the Attachment of the 9 O'clock Cast A356T1 Aluminum Strut to the A110AT Titanium Cold-Side Sector. Also Shown is the Speed Pickup Housing Attaching Boss.

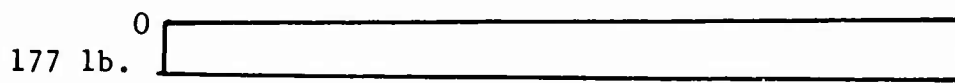


Sectional Properties	Location X					
	3	5	9	12	31	33.85
$I_{\max}$	2.68	2.68	2.68	2.4	1.1	0.9
$I_{\min}$	0.518	0.326	0.047	0.44	0.031	-
A	2.179	1.816	1.06	1.03	0.860	0.834
J	0.021	0.0205	0.02	0.019	0.0174	0.017
$C_{\min}$	0.86	0.86	0.345	0.345	0.345	0.345
$C_{\max}$	1.9	2.035	2.4	2.442	1.98	0.4

Figure 25. Sectional Properties of 9 O'clock Strut (Drawing 4012001-381, Figure 8).



a) Maximum Induced Loading with 2 Rad/Sec Gyro is Reacted by the 3 o'clock Strut Using a Factor of 3.



b) Shear Diagram



c) Bending Moment Diagram

Figure 26. Load, Shear, and Bending Moment Diagram for the 9 O'clock Strut.

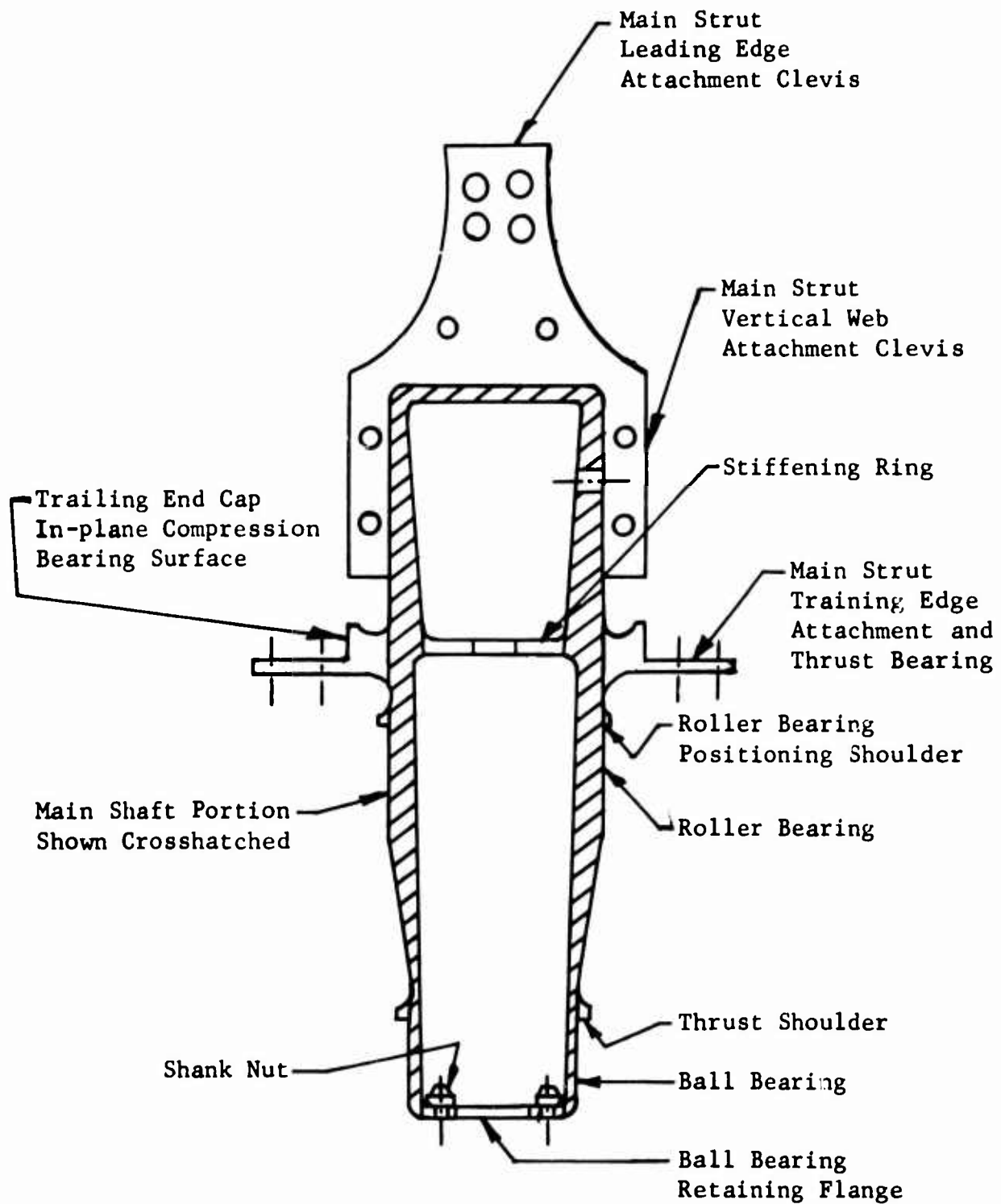


Figure 27. View Showing Cross Section of Hub In-plane of Major Strut for the Purpose of Identifying its Integral Component Parts, See Figure 28.

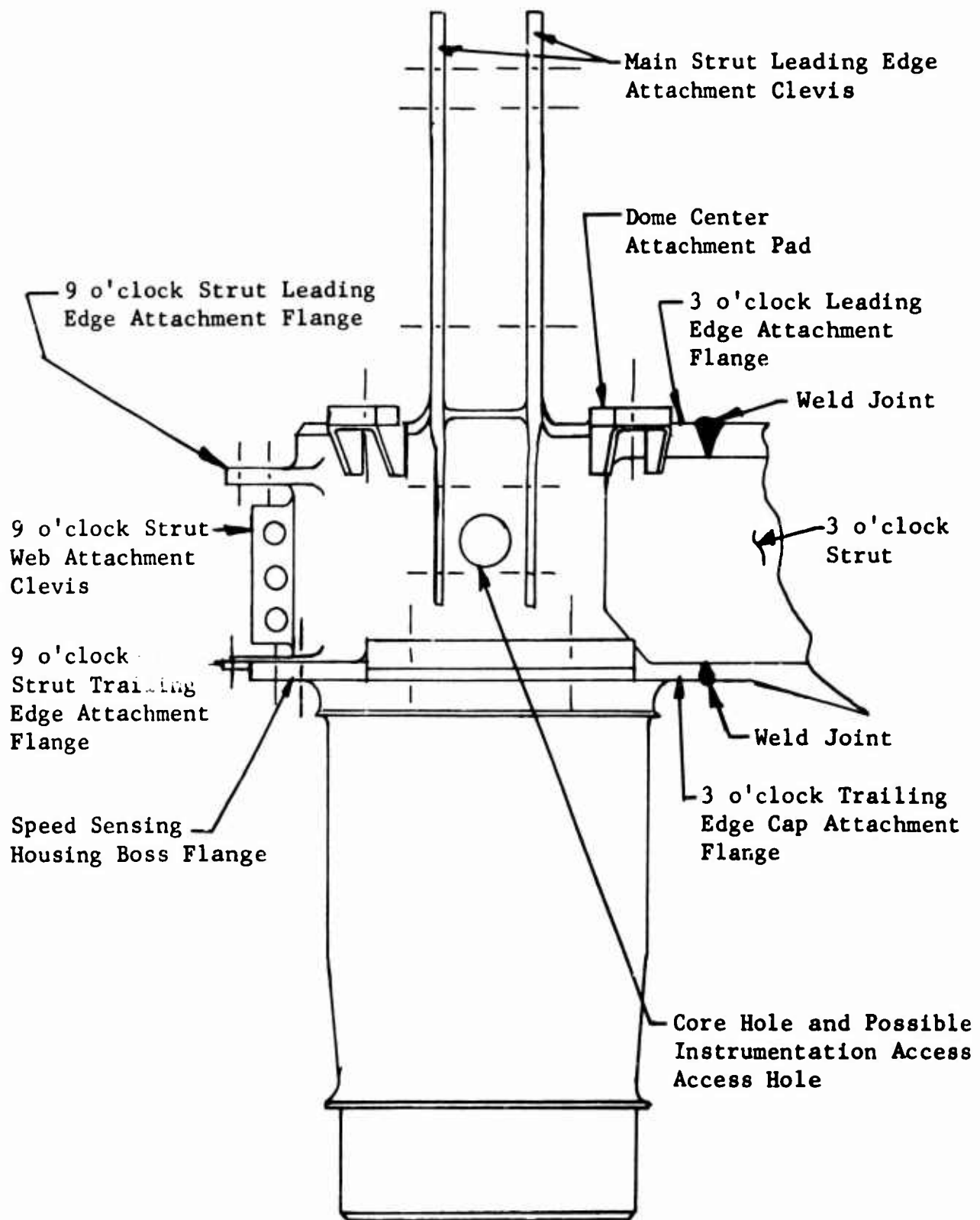
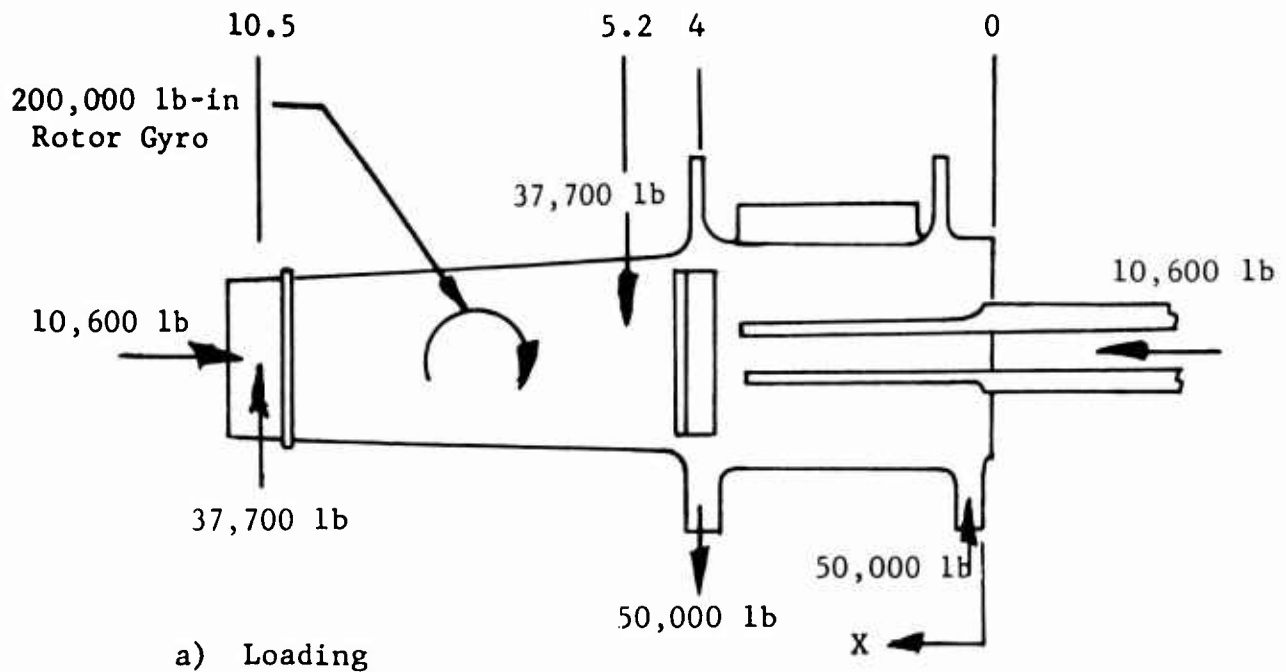
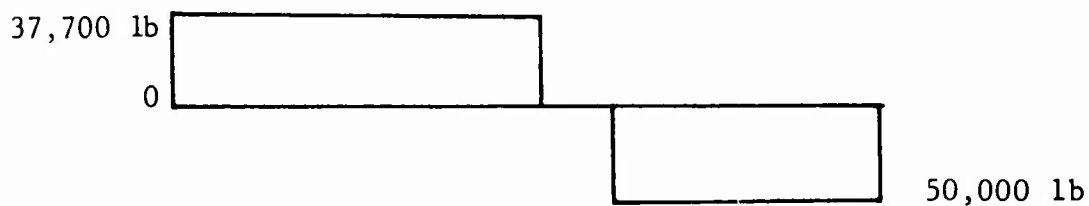


Figure 28. View Showing Hub Normal to 3 O'clock Strut for Purpose of Identifying the Hub Shaft Integral Component Parts, See Figure 27.



Sectional Properties	Location									
	0	0.6	3.7	4	4.4	4.68	6.68	9.7	10.5	
I	25.2	4	19.5	25	9.1	7.85	7.2	3.92	3.4	
A	17.8	1.46	9.35	17	4.35	3.8	3.65	2.46	2.23	

b) Cross-Sectional Properties



c) Shear Diagram



Figure 29. Cross-Sectional Properties and Load Diagram of the Shaft Portion of the Hub With 200,000 Pound-Inches of Gyro Reacted by the 3 O'clock Strut.

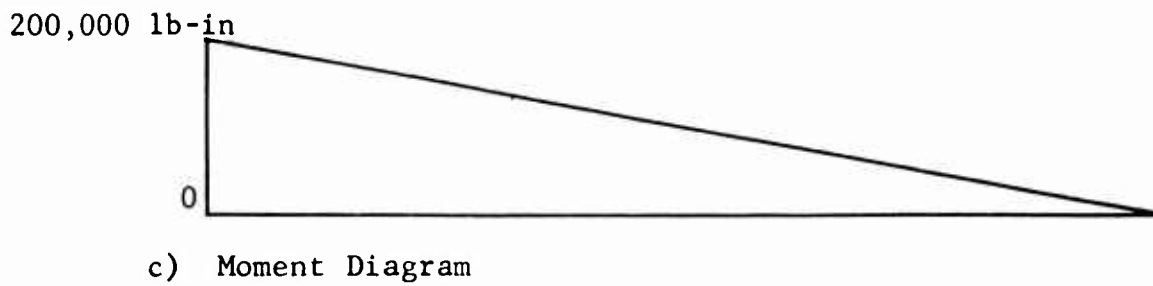
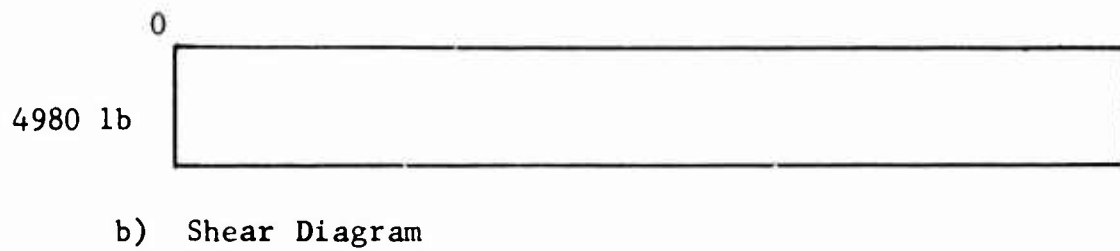
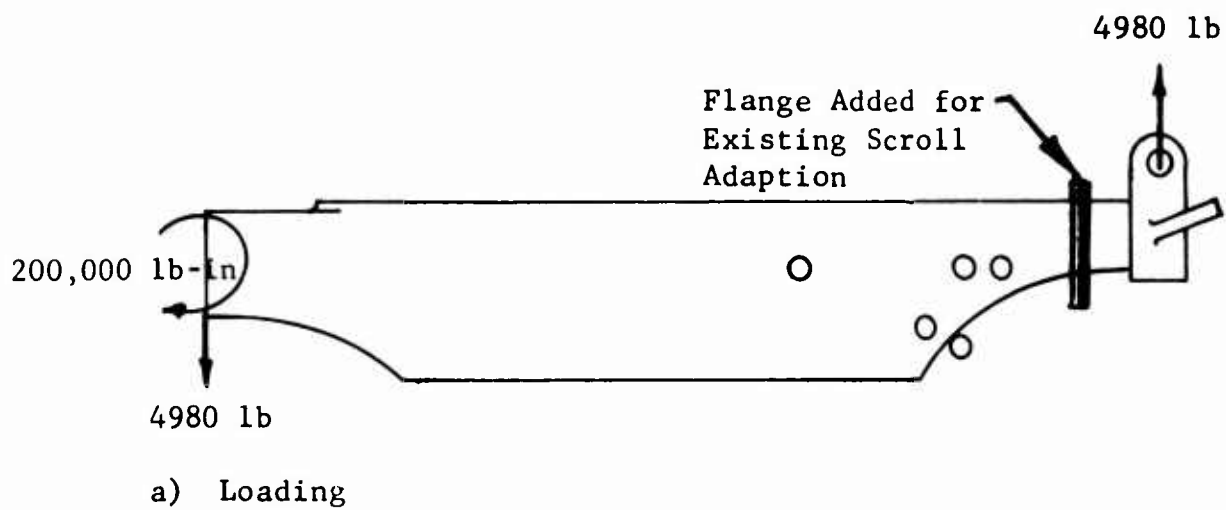
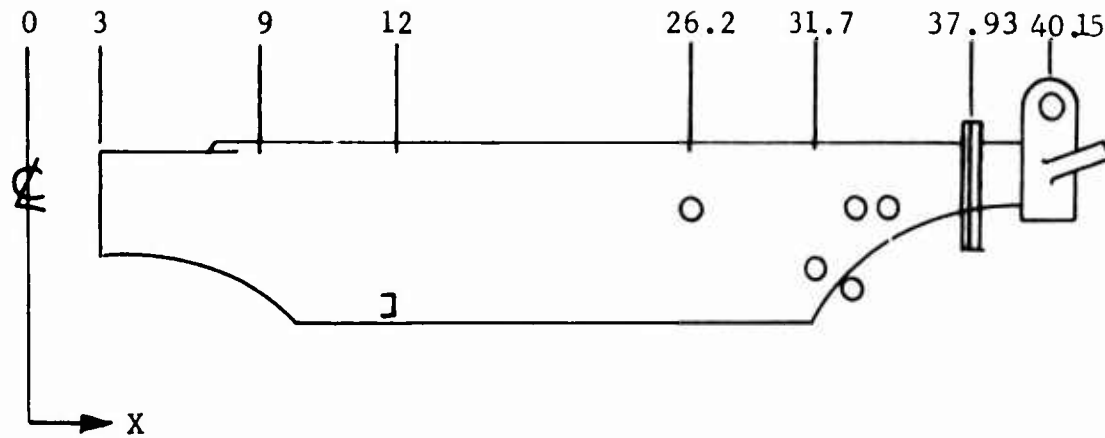
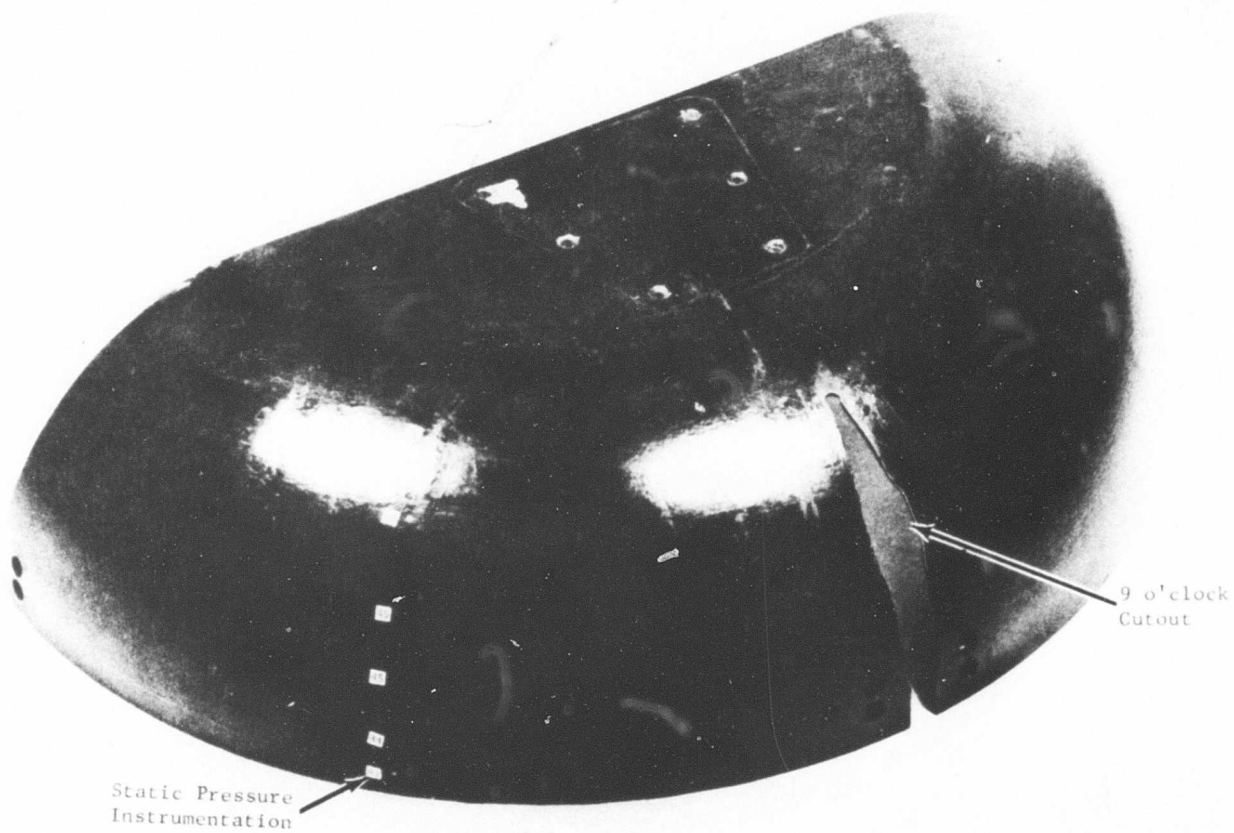


Figure 30. Loading, Shear, and Moment Diagrams for the 3 O'clock Strut for Reacting 2 Rad/Sec Gyro.



Sectional Properties	Location						
	3	9	12	26.2	31.7	37.93	40.15
$I_{Max}$	6.7	5.81	5.48	3.6	2.5	0.88	0.285
$I_{Min}$	2.33	0.95	0.089	0.064	0.055	0.058	0.285
A	1.98	1.587	1.48	0.9	0.66	0.55	1.685
J	0.213	0.206	0.204	0.19	0.185	0.163	0.133
$C_{Max}$	2.8	2.8	2.8	2.8	2.8	1.45	-
$C_{Min}$	1.7	0.5	0.5	0.5	0.5	0.5	1.05

Figure 31. Cross-Sectional Properties of the 3 O'clock Strut (Drawing 4012001-386, Figure 4).



**Figure 32.** LF-2 Front Frame Epoxy Glass Laminate Dome - 9 O'clock Half.

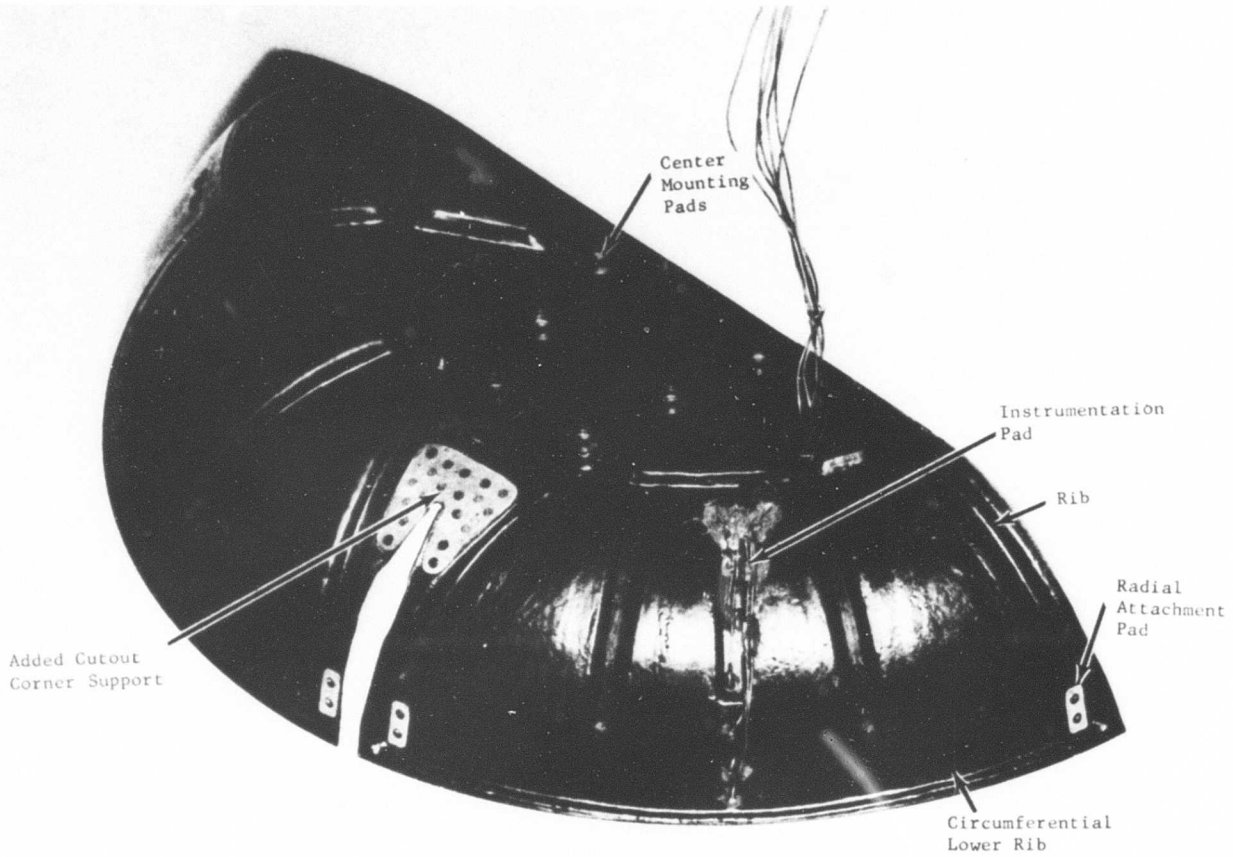


Figure 33. LF-2 Front Frame Epoxy Glass Laminate Dome -  
9 O'clock Half View Showing the Rib Structure.

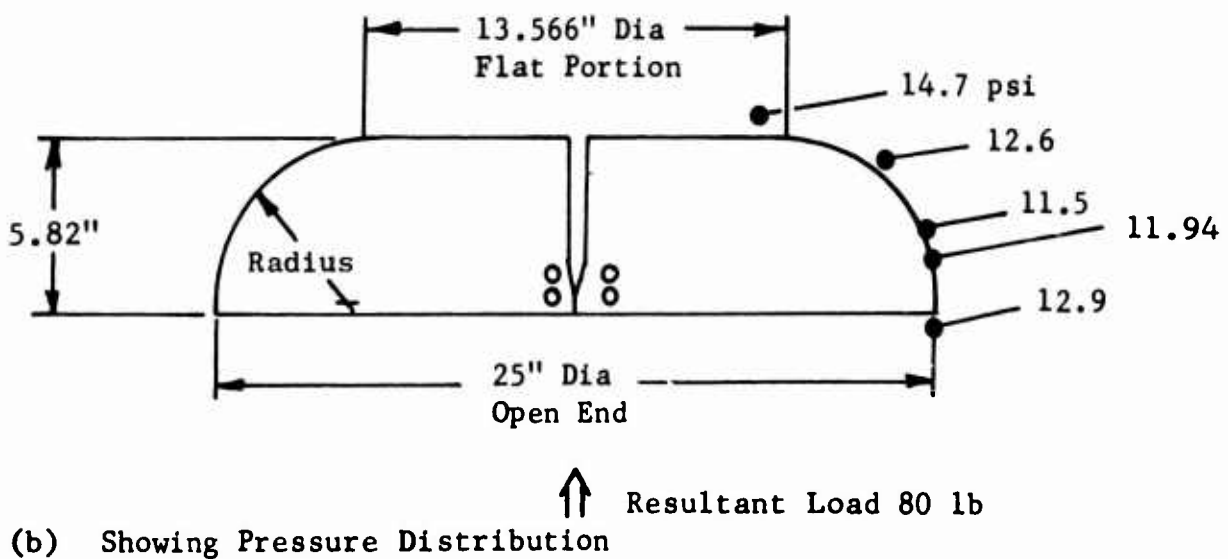
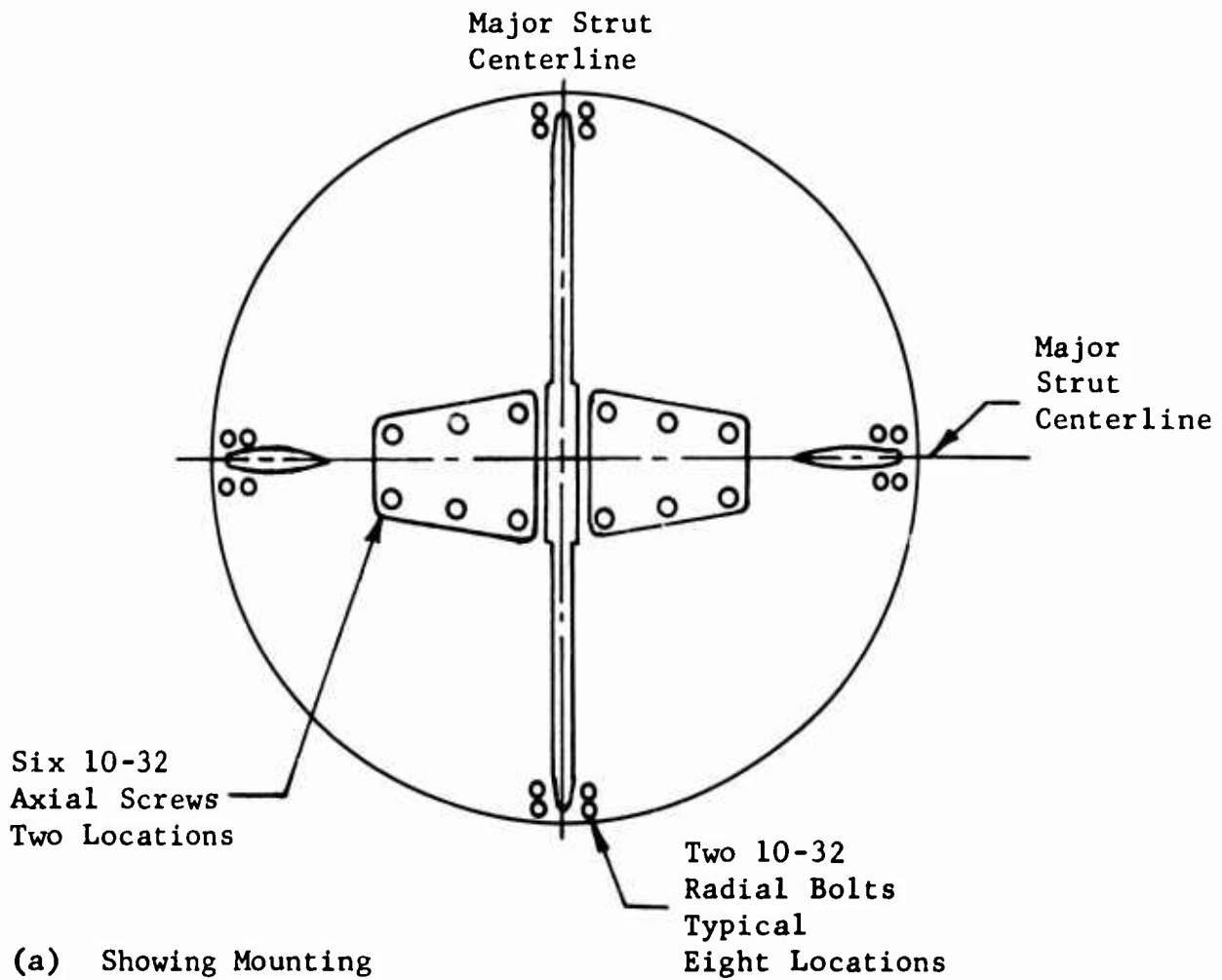
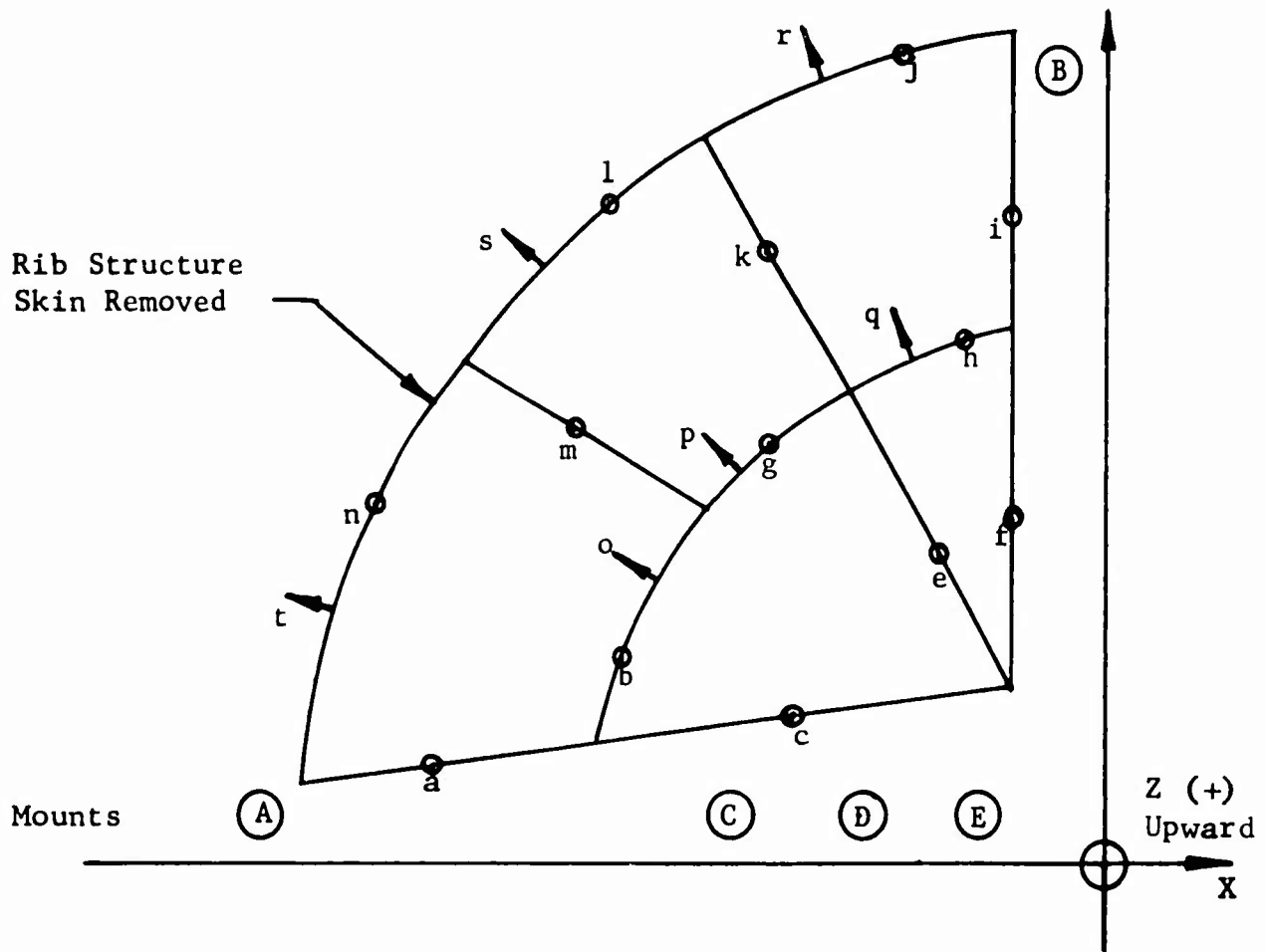
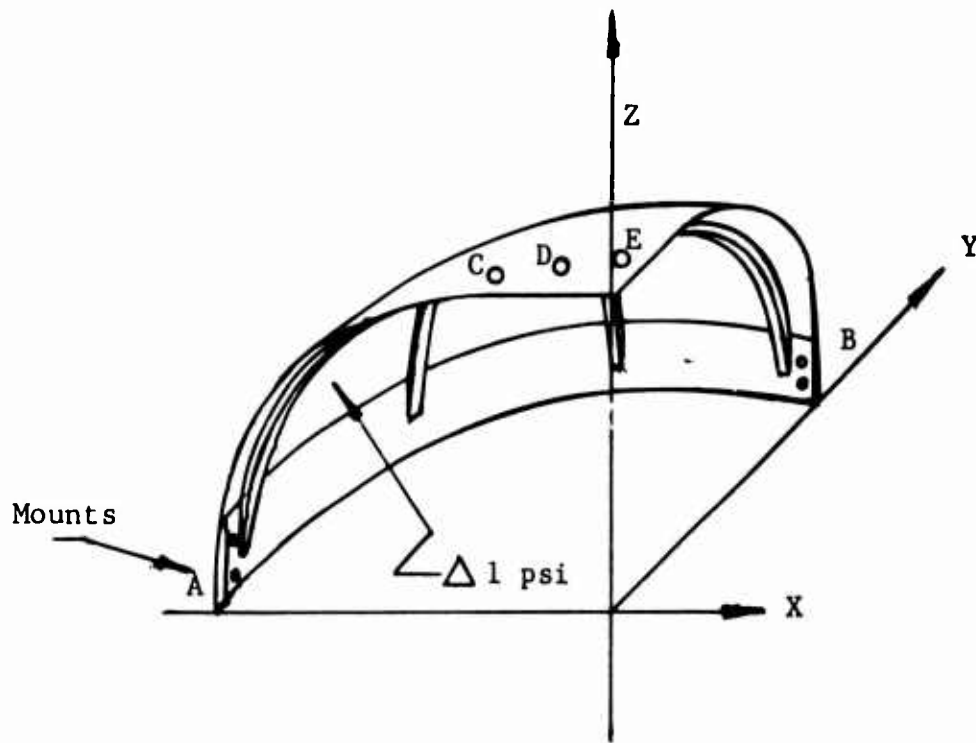


Figure 34. Dome Mounting and Pressure Loading.



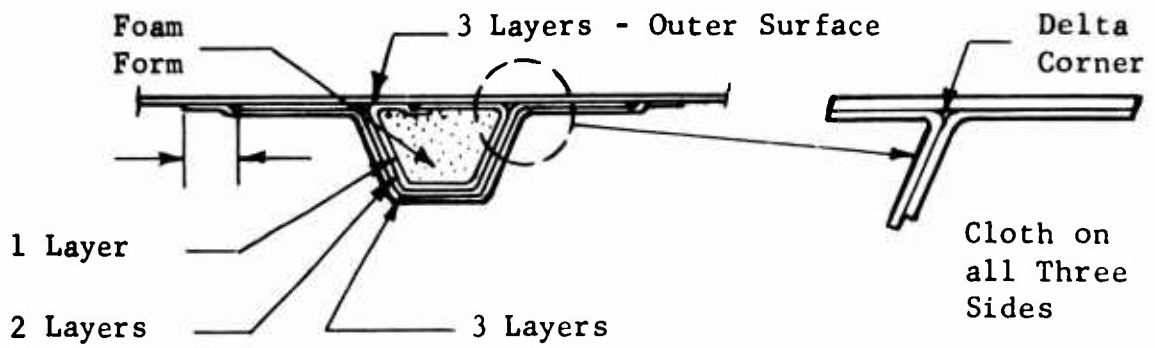
Axial lb/in		Radial lb/in	
a.	2.91	o.	1.76 Radial
b.	1.76	p.	1.67 Radial
c.	0.75	q.	1.4 Radial
d.	0.53	r.	1.4 Radial
e.	1.28	s.	1.6 Radial
f.	0.53	t.	1.01 Radial
g.	2.35		
h.	1.93		
i.	2.41 Radial		
j.	1.4		
k.	3.0 Radial		
l.	1.6		
m.	2.61 Radial		
n.	1.01		

Figure 35. Assumed Running Loading on Quarter Dome Rib Structure Due to a 1.17-psi Pressure Rise in Dome Cavity.

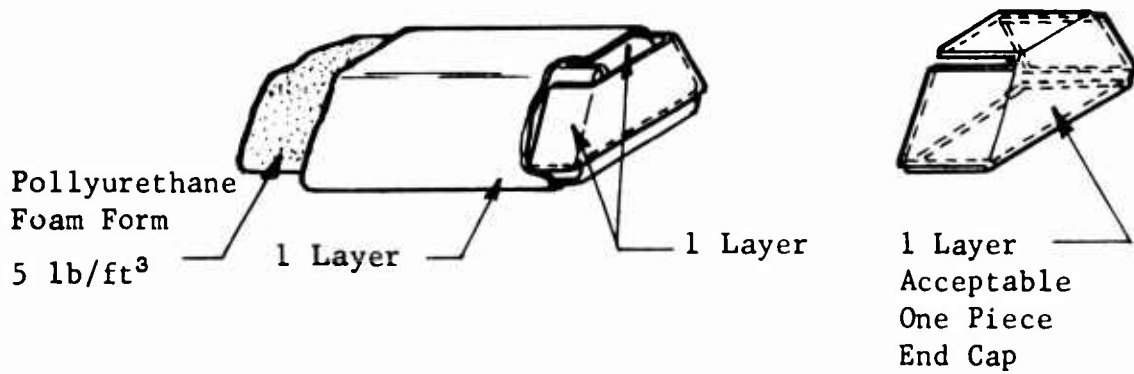


Mount Locations	Direction		
	X	Y	Z
A	-7.5	-24.8	-50.4
B	29.9	16	-63
C	15.3	-12.7	-13.8
D	2.6	6.6	- 4.8
E	30.6	-52.4	-12
			<hr/> Total Axial = 144# Designed vs. 20# Actual

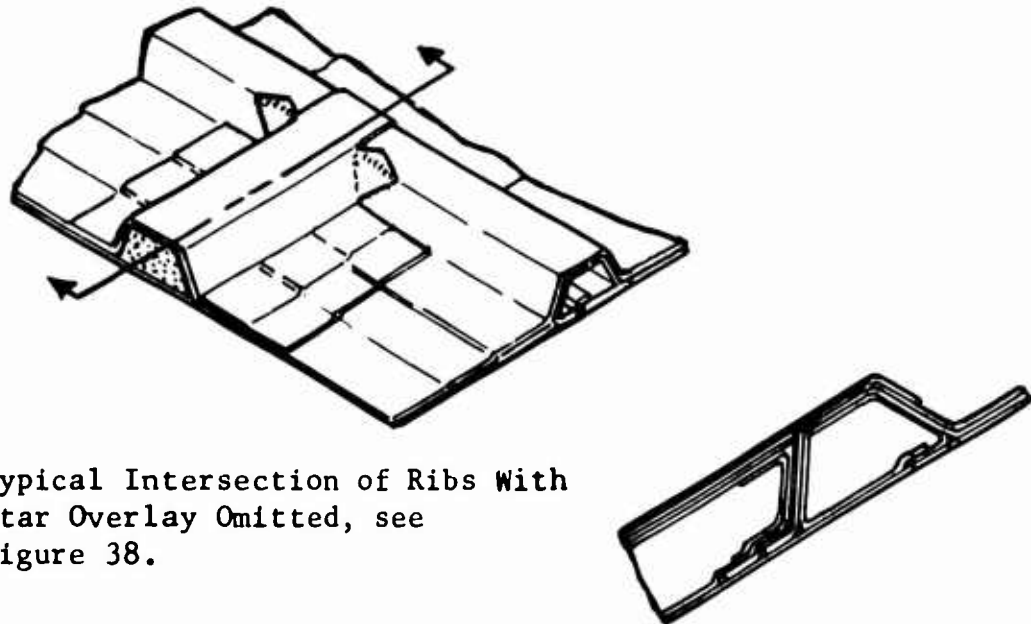
Figure 36. Quarter Dome Mounting Reactions for Design of a 1.17-psi Rise in the Dome Cavity.



(a) Typical Rib Cross Section Construction.



(b) Typical First Wrap of Ribs Producing First Step in Delta Corner Construction.



(c) Typical Intersection of Ribs With Star Overlay Omitted, see Figure 38.

Figure 37. Showing Typical Joint Construction Used in the Manufacturing of the Dome.

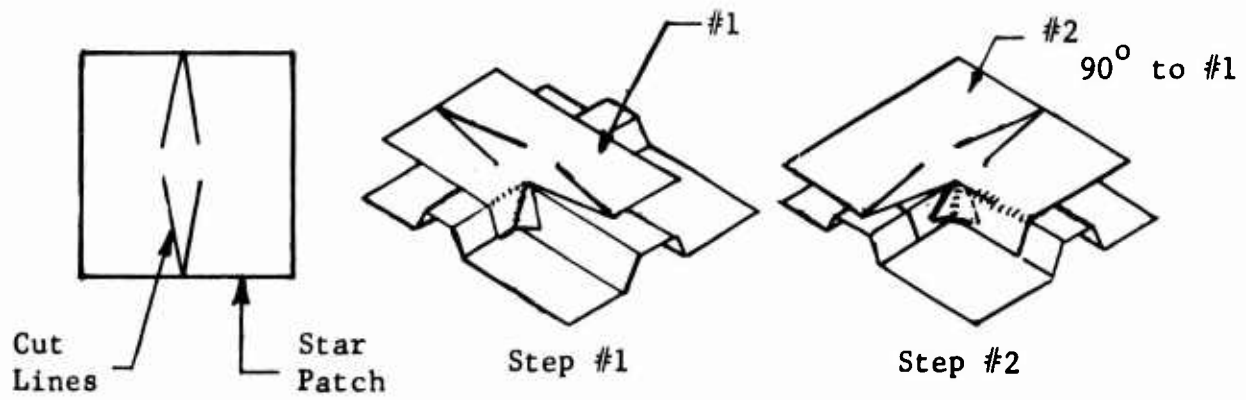
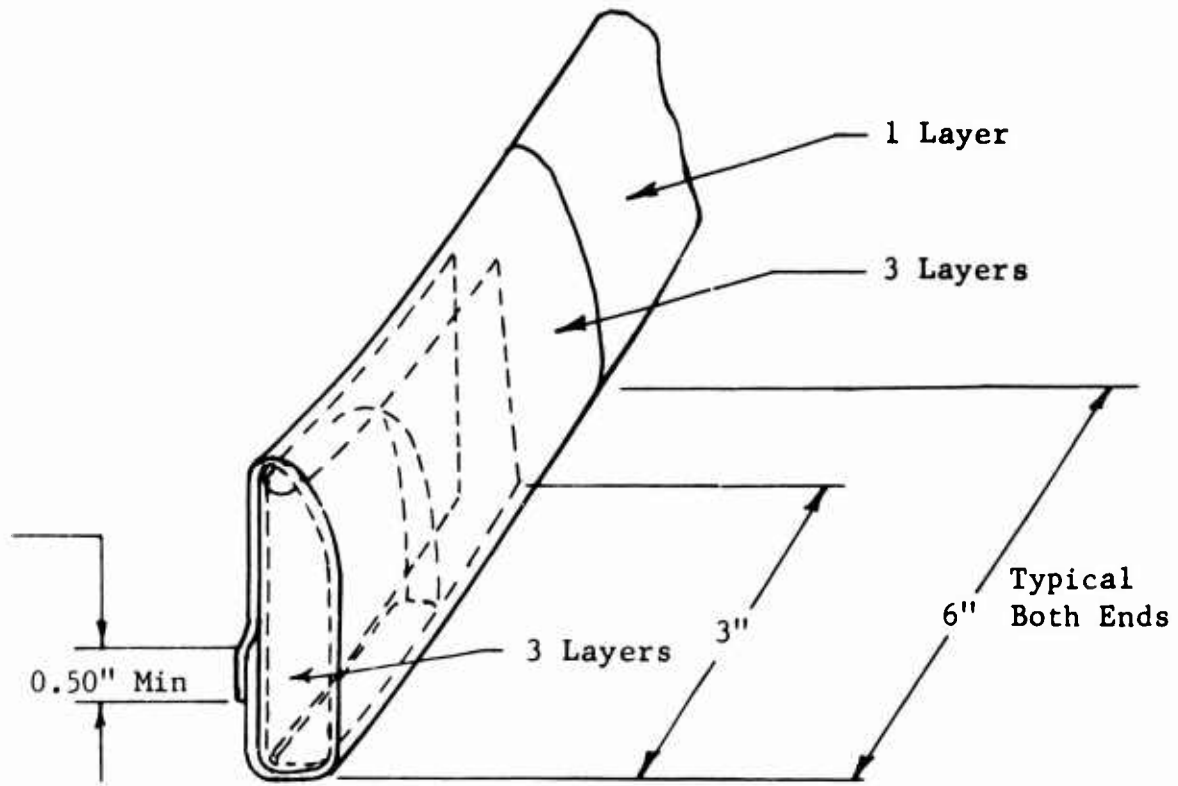
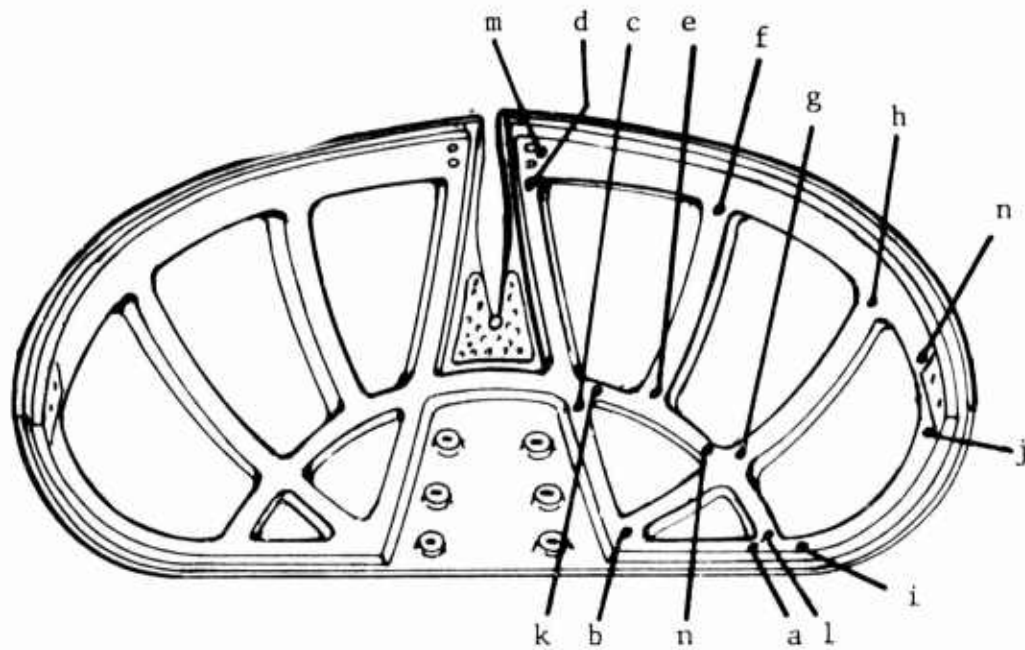


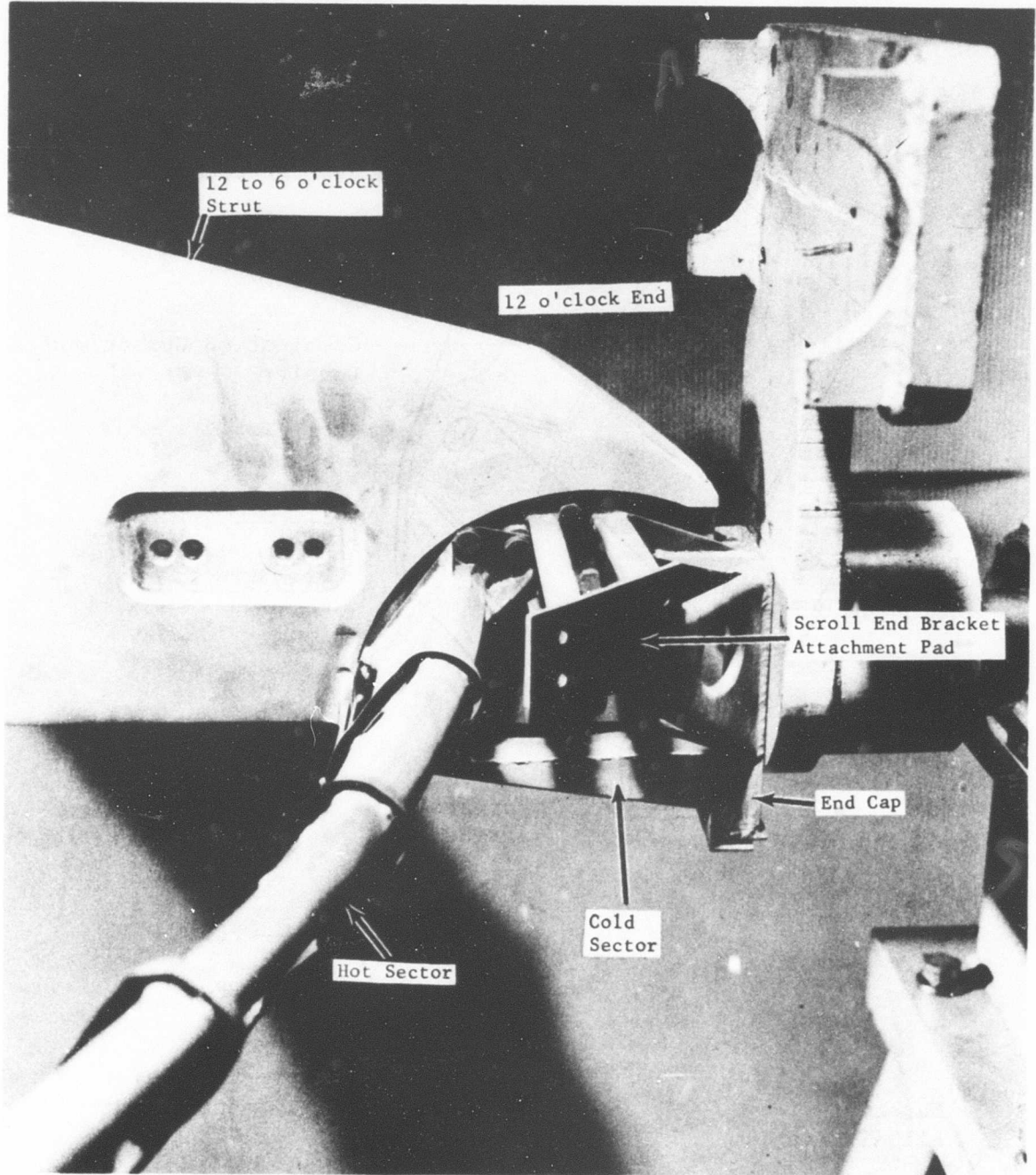
Figure 38. Showing Typical Star Lay-up Over Rib Junctions Reinforcing the Joint.



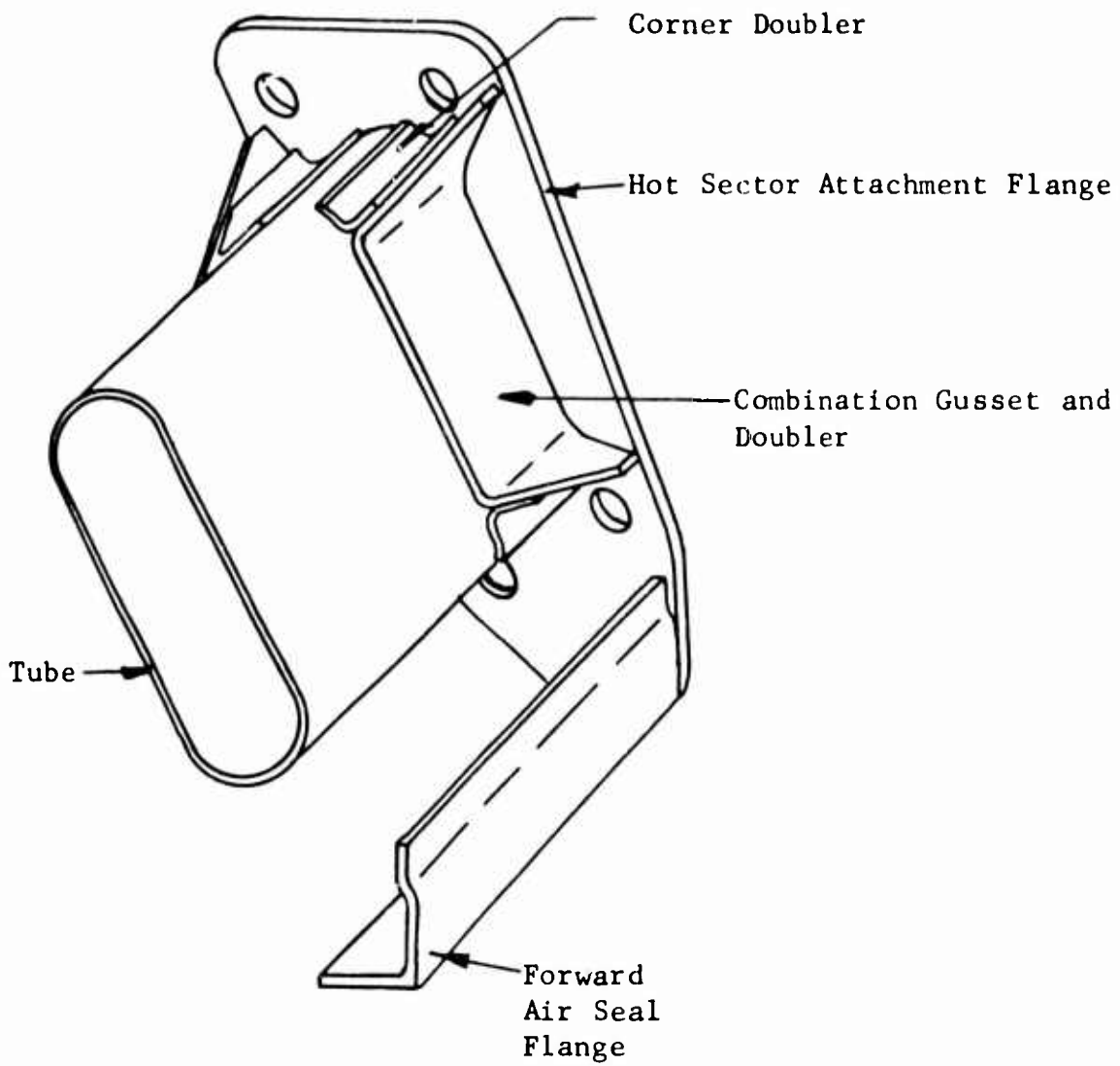
Location	Rib Minimum Axis Bending Stress
a	1004
b	1686c*
c	1245c*
d	2315
e	1606
f	2489c*
g	2343c*
h	1793c*
i	1285c*
j	1404c*
k	1070
l	996c*
m	1158
n	1619

\*c - Compressive Stress

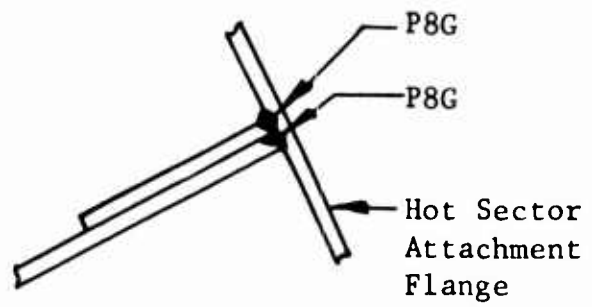
Figure 39. Dome Maximum Stresses and Approximate Location Showing Only Those Stresses of 900 psi and Higher.



**Figure 40.** LF-2 Front Frame View Showing Attachment of the 12 to 3 O'clock ALIOAT Titanium Hot-Side Sector to the 17-4 PH End Cap.



Material  
Al10AT Titanium



Section Showing Typical 100-Percent Tube Combination Gusset and Doubler Sheet Thickness Penetration Welds.

Figure 41. View Showing Hot-Side Sector Tube to End Attachment Flange Construction.

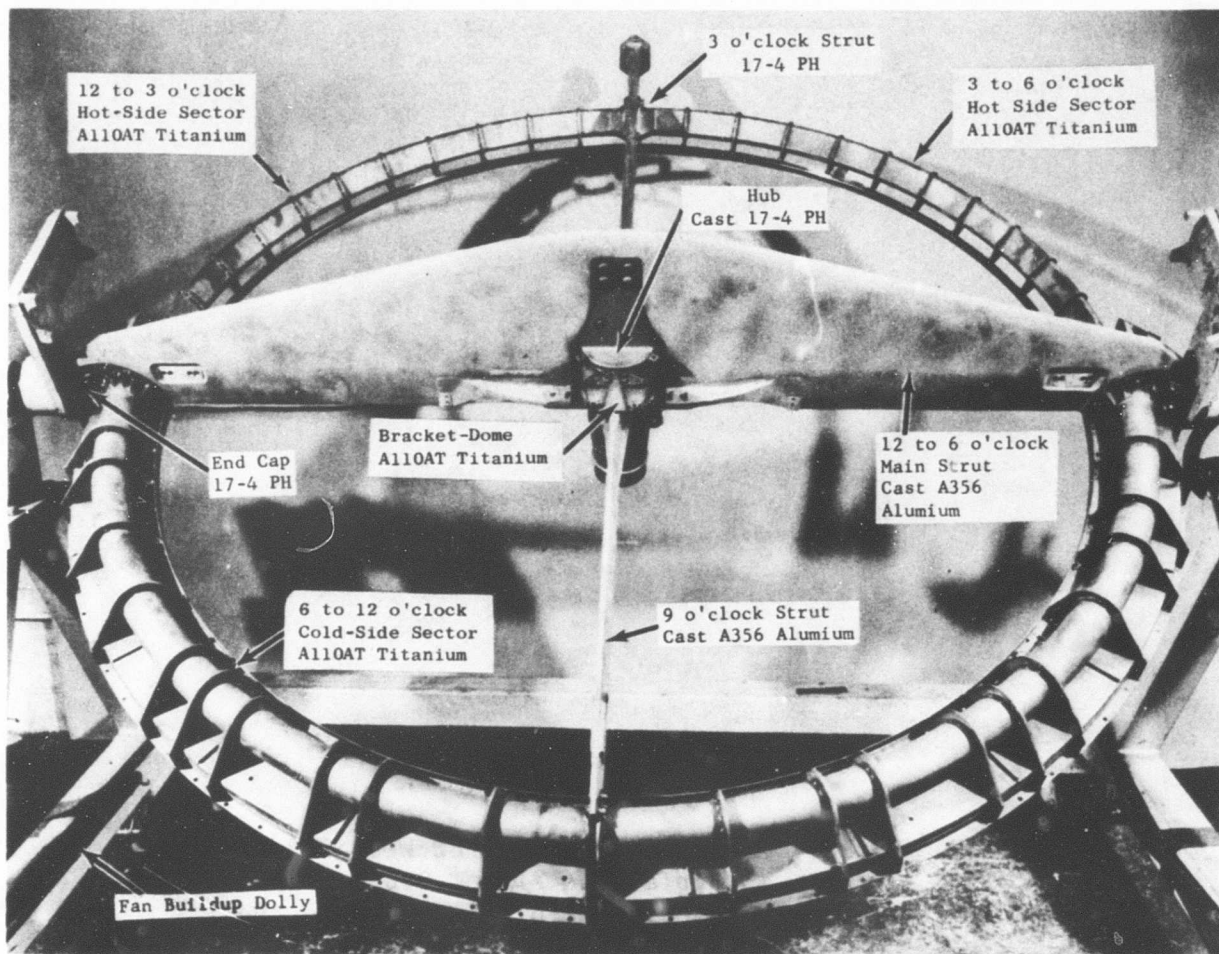
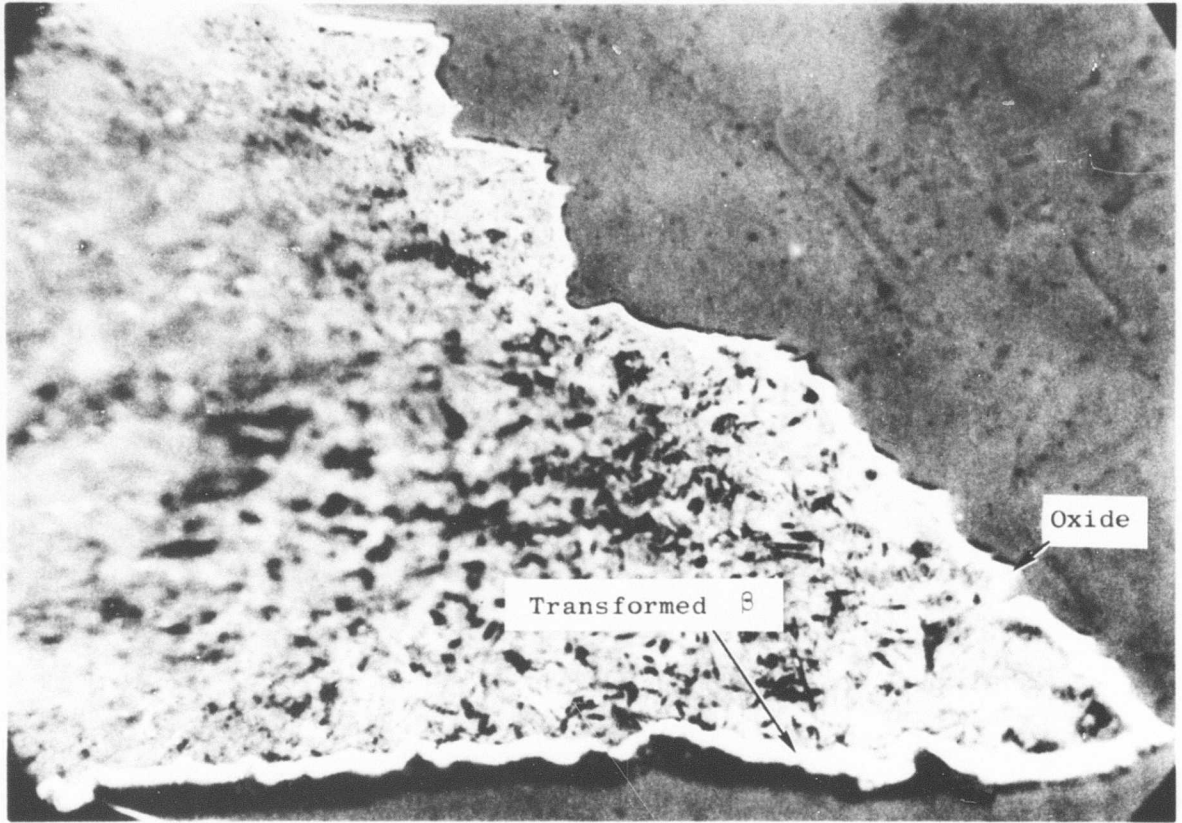
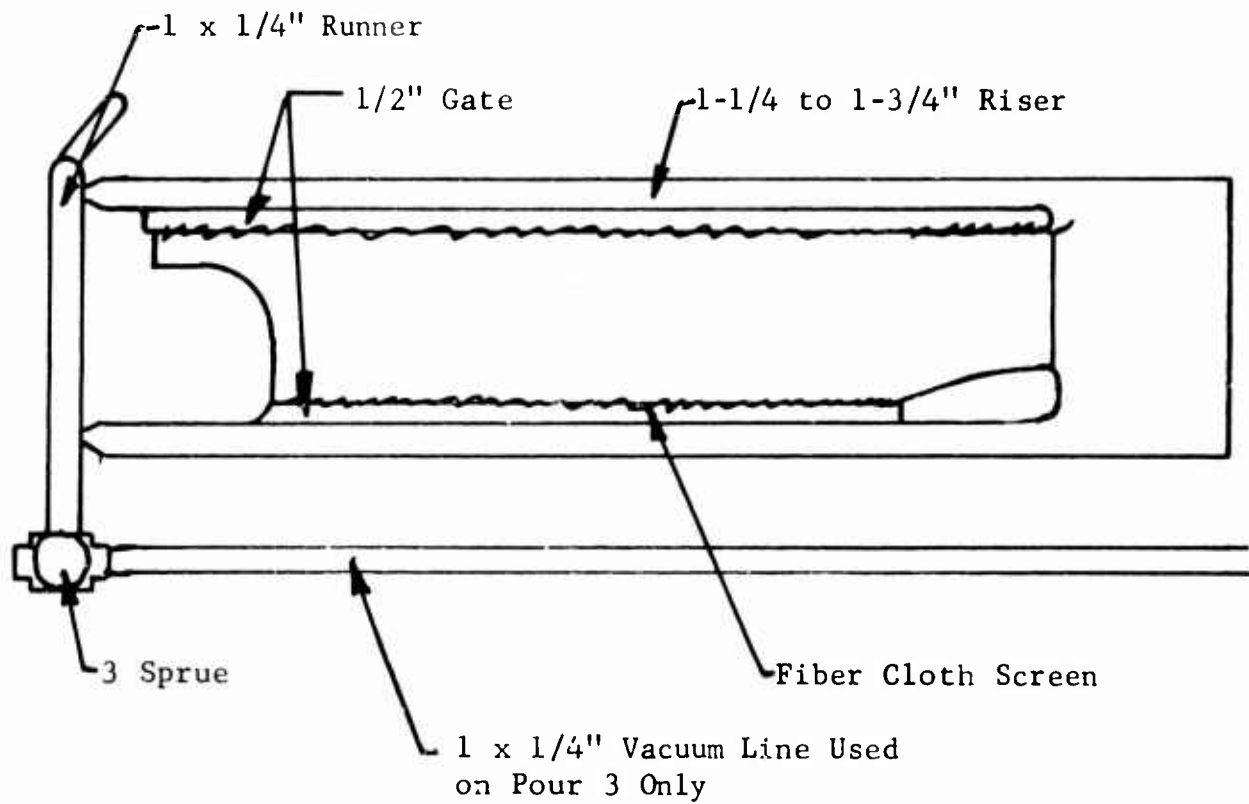


Figure 42. LF-2 75.26-Inch-Diameter Front Frame View Showing Component Subassemblies and Their Materials; the Dome Which is an Epoxy Fiber Glass Lay-up is not Shown.

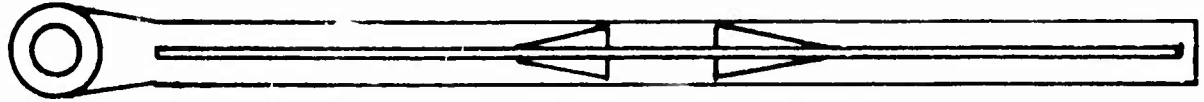


**Figure 43.** Photomicrograph (500X - Etched) Showing Cracked Surface in Al10AT 0.030-Inch Titanium Sheet Which Failed During the Cold-Side Tube Spinning Operation.



Metal Pouring Temperature - 1350°F  
 119 Pound Pour

Figure 44. Gating Layout for Green Sand Casting of the 9 O'clock A356 Aluminum Strut.



Metal Pouring Temperature - 1350°F  
 :50 Pounds Pour

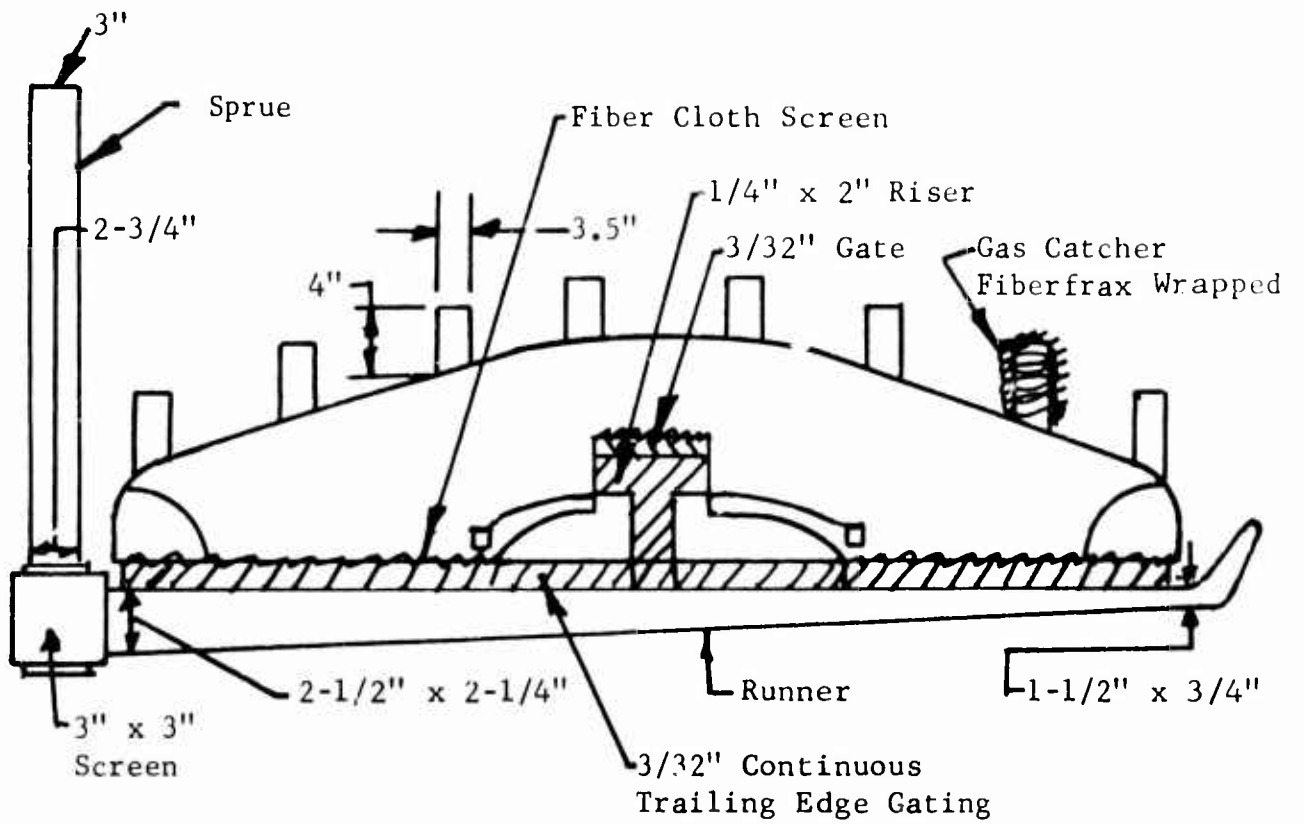


Figure 45. Gate Layout Used in Green Sand Mold for Casting the A356 Aluminum Major 12 to 6 O'clock Strut.

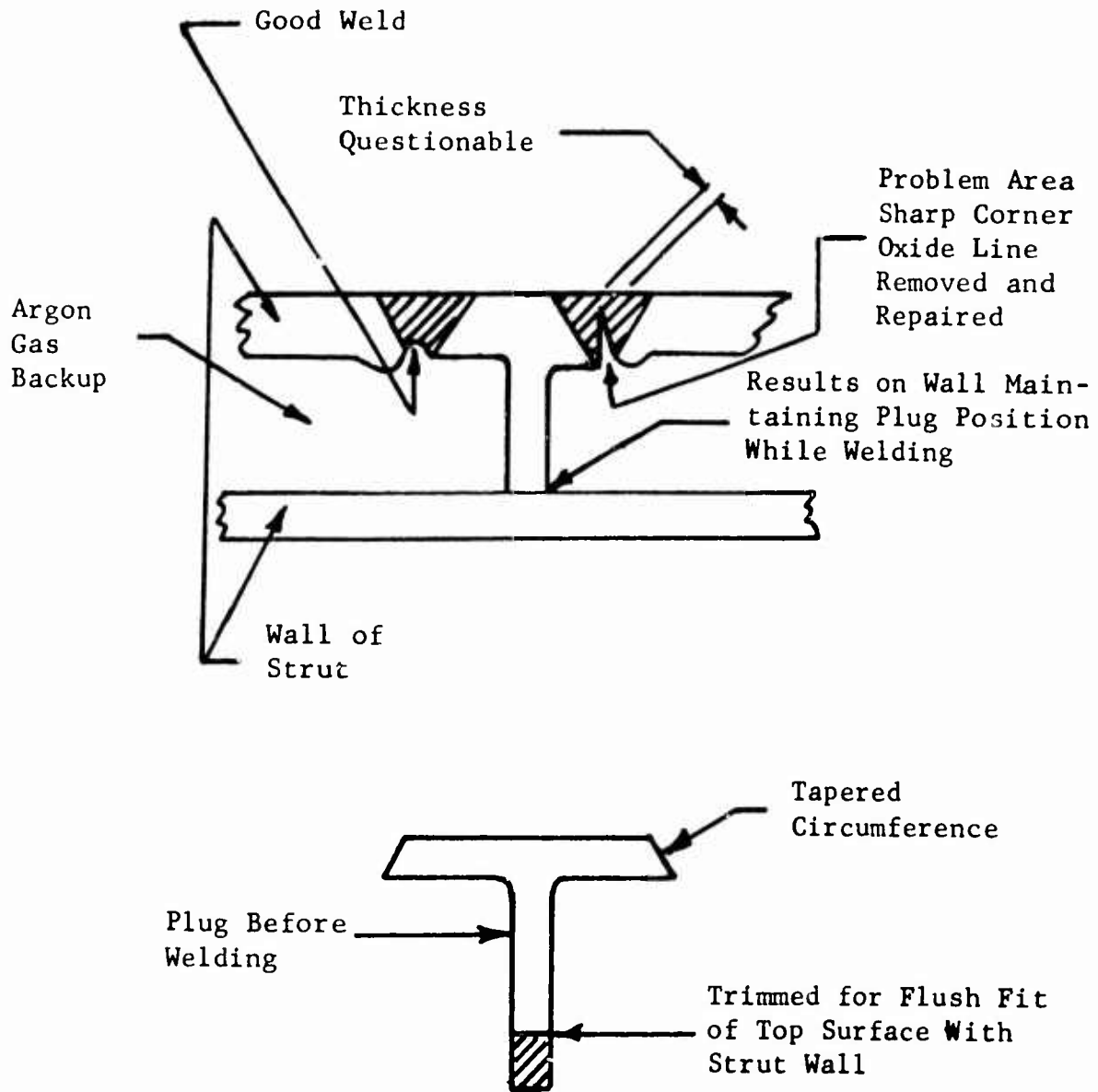


Figure 46. Core Hole Closure of the A356 Aluminum Strut Wall Showing Plug and Problem Requiring Repair.

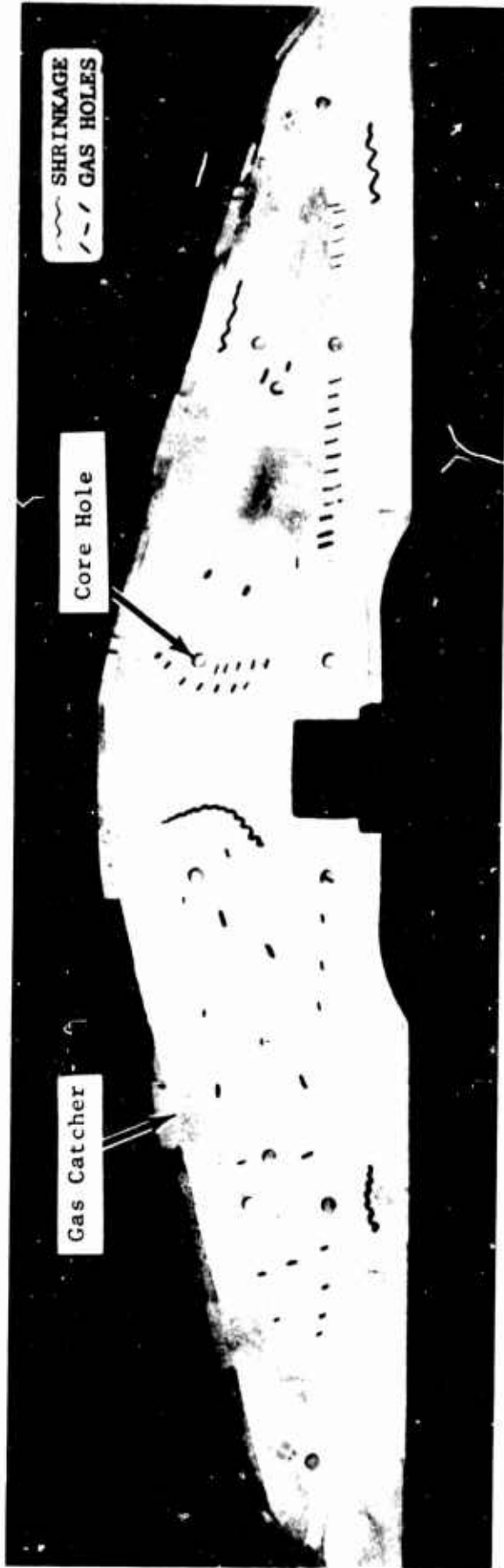


Figure 47. Major 12 to 6 O'clock A356 Aluminum as Cast Strut .  
Showing Problem Areas, Gas Catcher Locations,  
Size, and Core Holes.

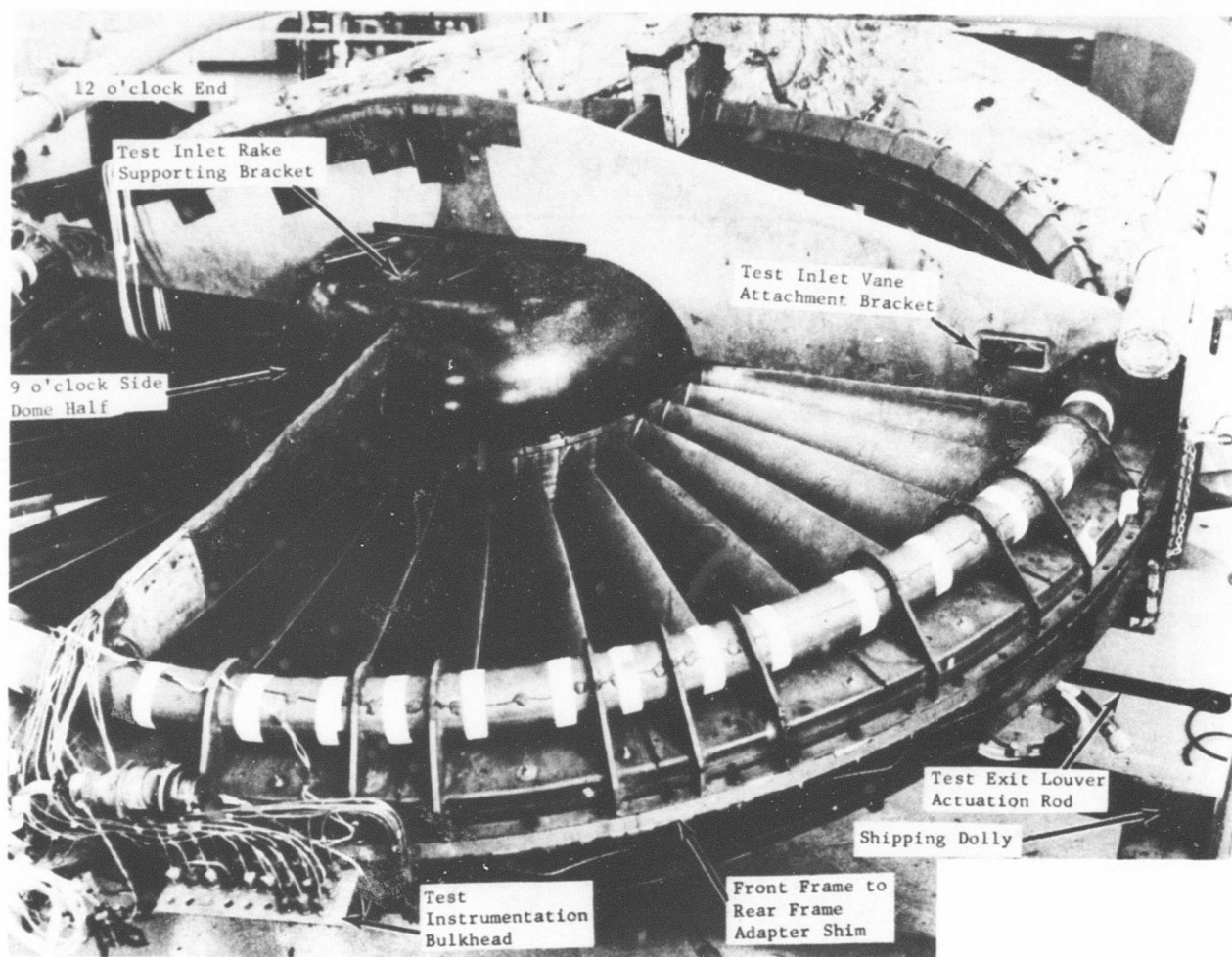


Figure 48. LF-2 Fan Assembly Removal from Test Facility Upon Termination of the 100-Percent Speed Checkout. The Epoxy Glass-Cloth Dome is Shown. A Front Frame to Rear Frame Adapter Spacer is Removed for Visual Inspection of Turbine Bucket Shrouds.

Cracks in Weld  
Affected Zone

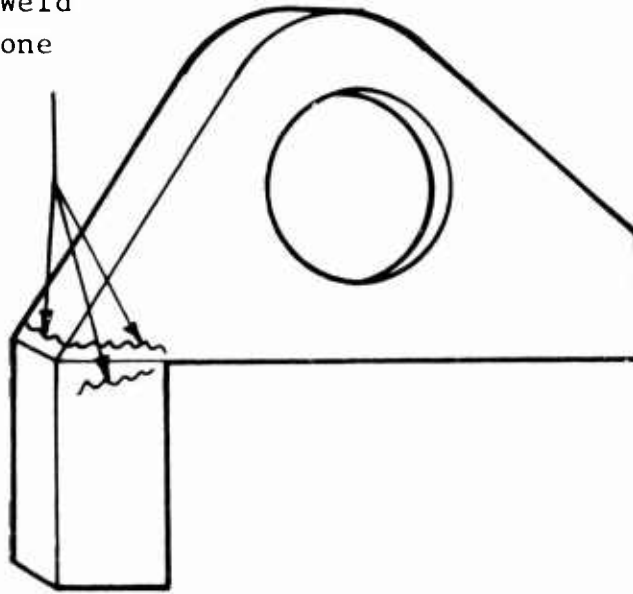


Figure 49. Showing Crack Locations in Weld Affected Zone of the Cold-Side Gusset, 0.015-Inch Stock Al10AT Titanium (Drawing 4012001-384P11) See Figure 11, Which Developed during Test.

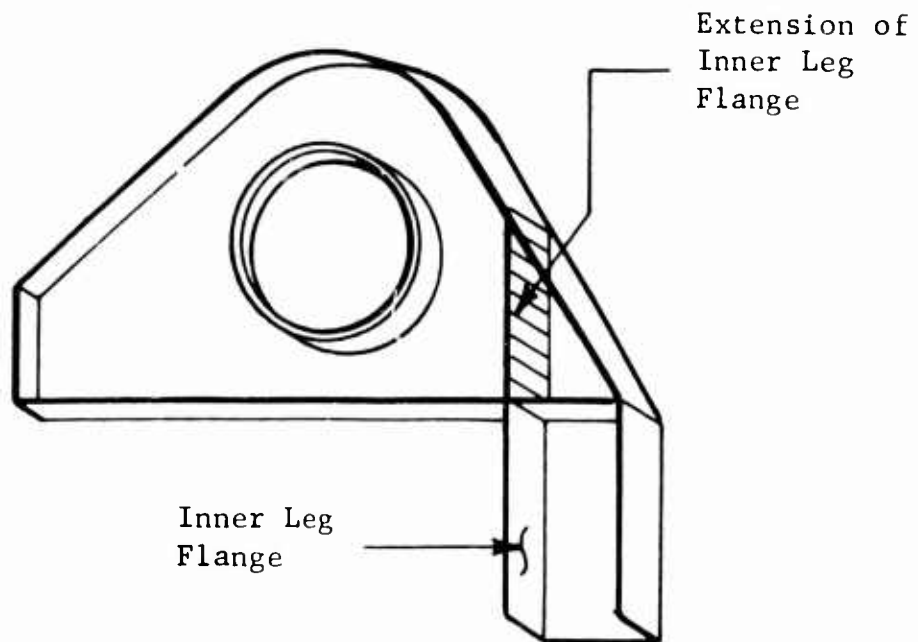
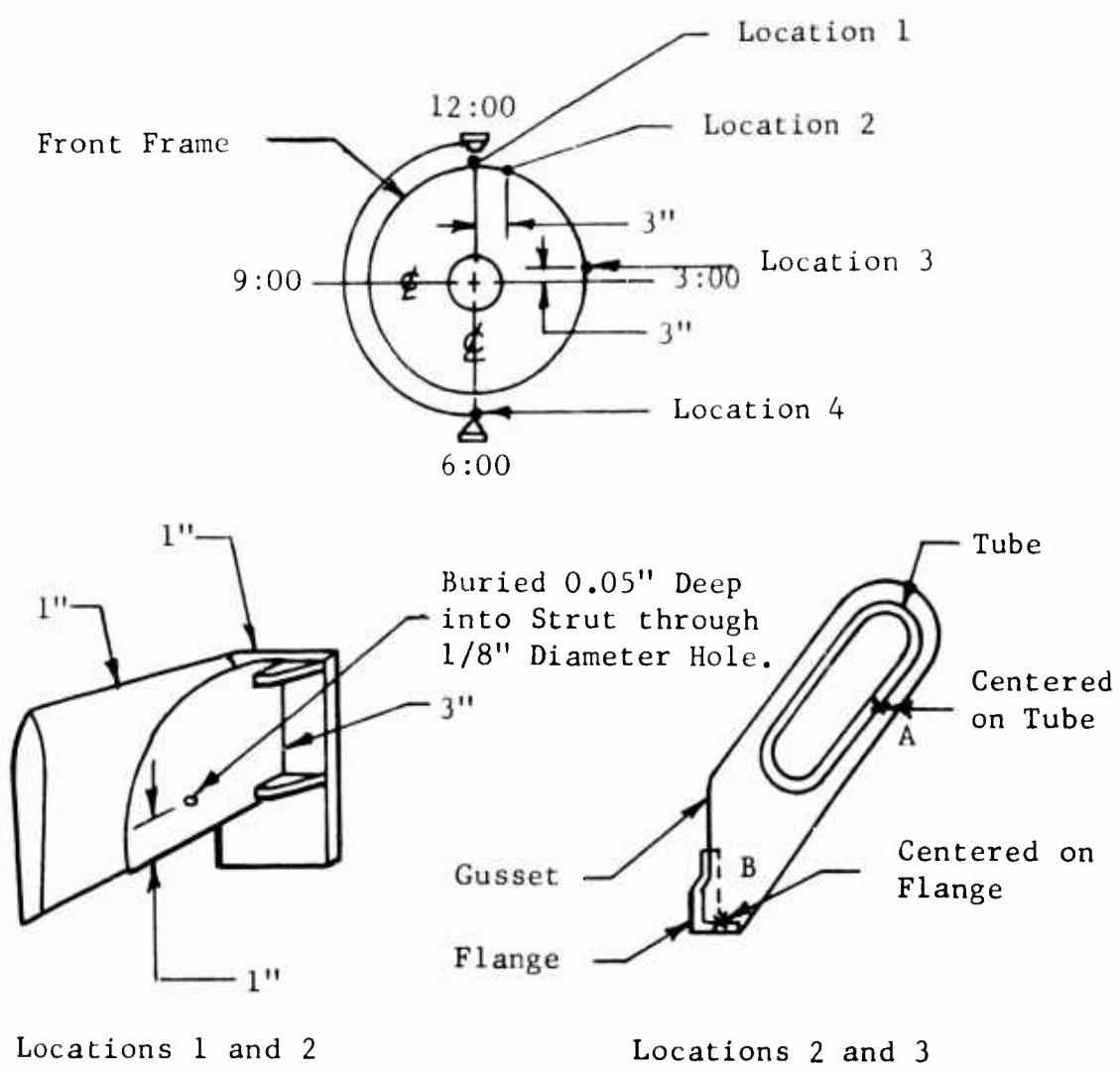


Figure 50. Showing Proposed Extension of the Inner Leg Flange to Improve Efficiency of Gusset to Remove Stress Concentration Area, See Figure 49 Above.



Fan Speed	Inlet Air	*Thermocouples				
		1	2A	2B	3B	4
Static	62	NR	NR	327	475	96
80%	67	NR	NR	216	410	104
90%	67	NR	NR	226	94	85
97%	39	NR	NR	200	208	108

\*Thermocouples were chrommel-alumel type AG28CT.

Figure 51. Showing Location of Front Frame Thermocouples and Their Output for Various Fan Speeds.

APPENDIX II

SUPPLEMENT MATERIAL INSTRUCTIONS

GENERAL  ELECTRIC

**A-4012154-967**

REV. NO.	TITLE	CONT. ON SHEET	SH. NO.
<b>A-4012154-967</b>	<b>INSTRUCTIONS LF2 ALUMINUM CAST STRUT</b>	<b>2</b>	<b>1</b>
CONT. ON SHEET	FIRST MADE FOR		
<b>2</b>	<b>4012154-967 LF-2 Aluminum Cast Struts</b>		

**4012154-967 LF-2 Aluminum Cast Struts**  
**A356T6 Aluminum Front Frame**

REVISIONS

This instruction supplements the General Electric drawings 4012001-380 and 381, and AMS 4218 A

- The mold design employed shall be such that optimum properties are obtained in the shaded areas shown in Figures 1. and 2.
- All castings will require four (4) cast tensile specimens with each strut during heat treatment. The specimen shall be attached to the castings during solutioning, water quench and aging.
- One casting of each configuration shall be sectioned by the casting vendor after acceptable fluorescent penetrant, x-ray inspection, and heat treatment and specimens for testing taken as shown in Figure 1. Machining and testing shall conform to ASTM E8-54T. See Figures 1 and 2 for specimen location.
- The tensile specimens taken from the castings shall meet the following minimum properties:

	Area A	Area B
Tensile Strength, PSI	33,000	30,000
Yield Strength, PSI	25,000	20,000
% Elongation, 2"	2.0	2.0

- The casting vendor shall tensile test, at room temperature, two cast bars from each casting. The other two bars per casting shall be submitted to GE LFP Engineering. The cast bars shall meet the AMS 4218 A minimum requirement.
- Notarized test results in triplicate of all tensile test data will be submitted to GE LFP Engineering.
- Castings shall meet the fluorescent penetrant inspection standards shown on Page
- The castings shall meet the following standards when radiographically inspected per SI-212,000.

Radiographic Inspection Requirements									
Max. Allowable Limits									
Area	XA	XB	XC	XD	XE	XF	XG	XH	XJ
All	2	NA*	2	2	2	None	NA*	1	None

\* Not Acceptable.

- Weld repair and rework shall conform to SI-L-203,133 and requires approval of GE LFP Engineering.

1 JUL 30 1963  
2 MAY 15 1964

102/11A  
161  
53  
242  
38  
PRINTS TO

MADE BY <b>W.M. GARCIA 5/13/63</b>	APPROVALS <b>G.W. 5/14/63</b>	<b>EPLD</b>	<b>A-4012154-967</b>
ISSUED <b>HLWNT/JUNE 6, 1963</b>	<b>JC. 5/14/63</b>	<b>EVENDALE</b>	

FF-883-WA (2-59)  
PRINTED IN U.S.A.

V-193

REV NO	TITLE
A-4012154-967	INSTRUCTIONS LF2-ALUMINUM CAST STRUTS
CONT ON SHEET 3 SH NO 2	FIRST MADE FOR

Type Defect	Area	Max. Size	Min. Spec.	Other Requirements
Pits, porosity, gas holes, sand holes	All over except machined surfaces and inside strut walls	.060 Dia. .040 deep	.20	a) Max. of 5 per any 1" dia. circle. b) A total of 10 indications per any 4" of linear length
Linear depression.	All over except machined surfaces and inside strut walls.	.020 deep .060 wide 1.00 long	.50	a) Max. of 3 per any 4" dia. circle. b) Max. of 1 per any 4" of linear length

a) Nicks, scratches, score marks and cracks not allowed.  
 b) Surface visual defects and fluorescent penetrant indications may be removed by means of a free cutting .50 min. spherical radius tool to max. depth of .040 with the following exceptions:  
 (1) Stock removal must not extend into a final finish of a machine surface.  
 (2) Stock removal area may not cover more than 1.00" dia. and must be at least 2.00" from next adjacent area.  
 (3) Stock removal must not compromise drawing dimensions or tolerance.  
 c) Min. spacing based on closest edges of defects.

FLUORESCENT PENETRANT INSPECTION STANDARDS

REVISIONS	

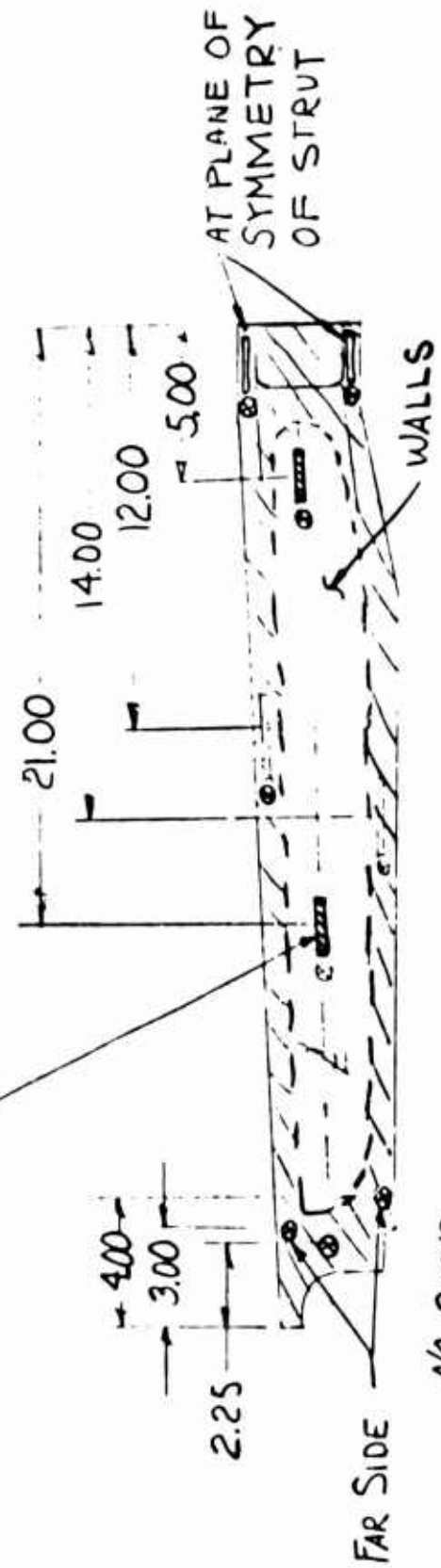
161
53
52 <sup>B</sup>
24 <sup>2</sup>
38
PRINTS TO

APPROVALS DW OR D.P.M. FPLD	DW OR D.P.M. A-4012154-967
ISSUED H.L. HOTT / JUN 6, 1963	LOCATION EVENDALE
FF-803-WA (2-59) PRINTED IN U.S.A.	CONT. ON SHEET 3 SH NO 2

V-193

REV		SIZE		A 4012154-967	
CONT ON SHEET 4		SH NO 3		DATE	
APPROVAL		DESCRIPTION		REVISIONS	
SYM	DATE				

NEAR FAR SIDE  
2 PLACES



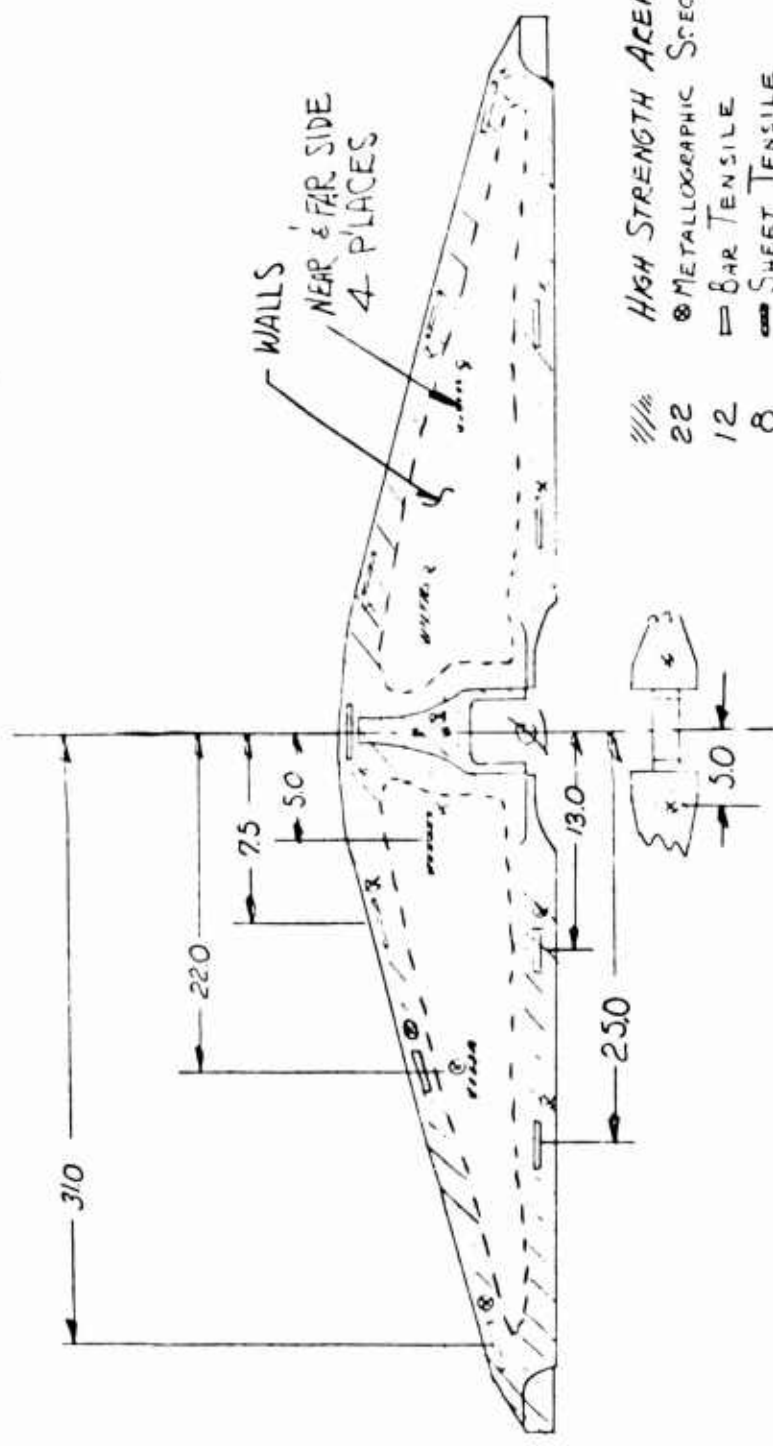
No. REQ'D	BAR TENSILE	161
4	SHEET TENSILE	53
4	METALLOGRAPH SPECIMAN	522
11	HIGH STRENGTH AREA	242
///		30

UNLESS OTHERWISE SPECIFIED DIMENSIONS ARE IN INCHES		DRAWN		GENERAL ELECTRIC	
TOLERANCES ON:		DATE		F.P.L.D.	
FRACTIONS		5-10-63		DIV OR DEPT	
DECIMALS		APPROVED		EVENDALE	
ANGLES		ENGR		LOCATION	
± .125 ±		MFG		SIZE	
ALL SURFACES ✓		MATERIAL		A 4012154-967	
MATERIAL		SCALE		CONT ON SHEET 4 SH NO 3	
GOVT. OR COML.		WT		V-193 1	
G.E.		SCALE			

9 O'CLOCK STRUT  
BAR & SPECIMAN  
LOCATION

REF DRWG 4012001-381

4012154-967		4012154-967	
SYM	REVISIONS	SYM	REVISIONS
	DESCRIPTION		DESCRIPTION
	DATE		DATE
	APPROVAL		APPROVAL



161	HIGH STRENGTH AREA
53	22 METALLOGRAPHIC SPECIMAN
52	12 BAR TENSILE
24	8 SHEET TENSILE
38	
POINTS TO	

UNLESS OTHERWISE SPECIFIED DIMENSIONS ARE IN INCHES TOLERANCES ON FRACTIONS DECIMALS ANGLES

ALL SURFACES  MATERIAL CONT OR CCN. C.E.

DRAWN 6/11/11 DATE 5/20/13 APPD [Signature] ISSUED [Signature] ENGR [Signature] MFG [Signature] MATL [Signature]

12-6 O-CLOCK STRUT SPECIMAN M.A.P. REF DWG. AD12001-380

GENERAL ELECTRIC FPLD ON OR DRN EVENDALE LOCATION

B 4012154-967

CONT ON SHEET FINISH NO 4 V-193

PRINTED IN U.S.A.

REV NO /  
A-4012154-969  
CONT ON SHEET 2 SH NO 1

TITLE INSTRUCTIONS  
LF2 FRONT FRAME HUB & STRUT  
FIRST MADE FOR

CONT ON SHEET 2 SH NO 1

17-4PH Front Frame Hub and Strut Instruction

This instruction defines material processing for front frame drawing 4012001-386 and includes the following information:

- I. Material Certification Requirement
- I. Process Certification Requirement
  - A. Casting
  - B. Wrought
- III. Joining
  - A. Spot Welding
  - B. Fusion Welding
  - C. Brazing
- IV. Heat Treatment
  - A. In Process Anneals
  - B. Castings
  - C. Final Assembly

The following specifications shall form a part of this instruction to the extent specified herein:

- AMS 5398A
- AMS 5643F
- AMS 2640F
- AMS 2635
- SI-212,000

I. Material Certification Requirement

All the material employed in the fabrication of the front frames must be laboratory tested, prior to manufacturing, to verify material supplier conformance to appropriate specification. All bar, sheet, and castings (cast bars) shall be tested and conform to AMS 5643F (bar and sheet) and AMS 5398 (castings) tensile requirements. Notarized certificates, in triplicate, of test results, along with material supplier certificates, will be submitted to G.E. LFP Engineering.

The cast hub shall be certified as follows:

REVISIONS

1	X.M.J. 9/14/63	SEP. 25, 63
		PA 154-969-1

102
MAC
161
53
24 <sup>2</sup>
38

PRINTS TO

APPROVALS W.M. GARCIA 5/13/63	APPROVALS GW. 5/13/63	AETD	DIV OR DEPT	A-4012154-969
ISSUED H.L. HOYT/JUNE 6, 1963	J.C. 5/13/63	EVENDALE	LOCATION	CONT ON SHEET 2 SH NO 1

PP 801 WA (1-63)  
PRINTED IN U.S.A.

V-193

CODE IDENT NO



GENERAL  ELECTRIC

A-4012154-969

REV NO /  
A-4012154-969  
CONT ON SHEET 4 SH NO 3

TITLE **INSTRUCTIONS**  
**LF2 FRONT FRAME HUB & STRUT**  
FIRST MADE FOR

CONT ON SHEET 4 SH NO 3

REVISIONS

5) The casting qualification procedure shall be as follows:

Cut Up Casting

- (a) Requires four (4) separately cast bars.
- (b) Casting shall pass x-ray and magnaflux inspection.
- (c) Casting and all four cast bars shall be homogenized and solutioned per AMS 5398A.
- (d) One (1) cast bar shall be aged and tested by casting vendor per AMS 5398A and must meet minimum mechanical properties.
- (e) Age casting and one (1) additional bar at 1025°F for one (1) hour. Cast bar and specimens taken from the casting shall meet instruction 4012154-969 Section II-3 minimums.
- (f) Remaining two (2) cast bars unaged shall be properly coded and delivered for hub/strut final assembly age.

Delivered Casting

- (a) Requires four (4) separately cast bars.
- (b) Casting shall pass x-ray and magnaflux inspection.
- (c) Casting and all four (4) cast bars shall be homogenized and solutioned per AMS 5398A.
- (d) One cast bar shall be aged and tested by casting vendor per AMS 5398A, and must meet minimum mechanical properties.
- (e) One cast bar shall be aged at 1025°F and tested by casting vendor and must meet instruction 4012154-969 Section II-3 minimums.
- (f) Remaining two (2) cast bars and casting shall be delivered unaged

II. Process Certification

Heat treating, casting, welding, cleaning and inspection sources are subject to review by G.E. LFP Engineering.

Test coupons, as defined below are to accompany details and each final assembly through all thermal treatments. The location of the specimens will be resolved prior to final assembly heat treat by the vendor and G.E. LFP Engineering

1	W.M. Garcia 5/13/63	SEP-25-63
	J.L. Hoyt	PA-154-969-1

102
MAC
161
53
24 <sup>2</sup>
38
PRINTS TO

MADE BY: W.M. GARCIA 5/13/63  
ISSUED: H.L. HOYT / JUNE 6, 1963

APPROVALS: GW 5-13-63  
JL 5-13-63  
RPP

AETD  
EVENDALE

DIV OR DEPT: A-4012154-969  
LOCATION: CONT ON SHEET 4 SH NO 3

FF 303 WA (6-63)  
PRINTED IN U.S.A.

V-193

CODE IDENT NO

GENERAL ELECTRIC

A-4012154-969

NO. /	TITLE
A-4012154-969	INSTRUCTIONS
5 4	LF2 FRONT FRAME HUB & STRUT
5 4	FIRST MADE FOR

- 1) Two (2) cast tensile specimens representative of the casting involved in the assembly, plus two (2) cast tensiles from cut up casting. see 5 (r) page 3.
- 2) Three (3) sheet coupons 3-1/2" x 6" of the same heat employed in the assembly.
- 3) Three (3) bar coupons approximately 1" x 1" x 3-1/2" long of the same heat employed in the assembly.

The coupons are to be positively identified as to location during final assembly heat treat, heat number of the material and final assembly they represent. Acceptance of the part is contingent on tensile bar and sheet specimens, from coupons, meeting the following minimums after aging at 1025°F for one (1) hour.

Bar and Sheet      Cast Bars & Cast Shaft Spec.

Ult. psi	155,000	155,000
.2% Yield psi	145,000	130,000
% Elongation	15 bar, 5 sheet	6%
% Red. of Area	45 bar	15%

III. Joining

A. Resistance Welding

- (1) All resistance welding must conform to G.E. Specification M50Ti, Section 3.
- (2) The results of set up tests per paragraph 3.G.2.2 must be available for audit by G.E. LFP Engineering. All three tests, tensile, weld size, and penetration and internal defects, will be performed.
- (3) A notarized certificate in triplicate, of set up results per paragraph 3.G.2.2 and production run test specimens per paragraph 3.G.2.3 will be submitted to G.E. LFP Engineering.
- (4) Weld size tests will be performed by both the etch method and the pull tests.

B. Fusion Welding

- (1) Fusion welding shall be performed by welders certified per Mil-T-5021-A-2.
- (2) All welding will be performed on material in the 1900°F annealed condition.
- (3) Welds shall be magnetic particle and x-ray inspected per drawing note.

REVISIONS	
1	2.11.1.14/15 SBPT. 2563 PA 154.914-1 PJP

102
MAC
161
53
242
38
PRINTS TO

W.M. GARCIA 5-13-63	G.W. 5-13-63	AETD	DIV. CH. DEPT.	A-4012154-969
H.L. HOYT / JUNE 6, 1963	J.C. 5-13-63	EVENDALE	LOCATION	5 4

PRINTED IN U.S.A.

MP

V-193

CODE IDENT NO

REV NO / A-4012154-969 CONT. ON SHEET 6 SH NO 5	TITLE <b>INSTRUCTIONS</b> <b>LF2 FRONT FRAME HUB &amp; STRUT</b> FIRST MADE FOR
---	--

**C. Brazing**

- (1) Brazing of the struts will be performed at approximately 1900° - 1950°F in a hydrogen or argon atmosphere \*F -40°F dewpoint or better at exit of furnace.
- (2) The braze filler metal will be specified by G.E. LFP Engineering.
- (3) The minimum acceptable braze limits, (bond efficiency), to be determined visually and by x-ray will be 80% with voids no larger than .100 x width of stiffener and spaced a minimum of .2" apart.
- (4) The braze process employed is subject to review by G.E. LFP Engineering.

**IV. Heat Treatment**

**A. In process anneals are to be performed as follows:**

- (1) Sheet metal parts:
  - a) A hydrogen or argon atmosphere of -80°F dewpoint or better entering the furnace and -40°F or better leaving the furnace is required.
  - b) Heat to 1900°F ± 25°F for 3 min. for each .100 inch of material thickness. Rapid air cool to 60°F for 1 hour.
- (2) Bar:
  - a) If parts are finished or have a finished surface exposed, an argon atmosphere per IV-A, 1-a, is required.
  - b) There is no atmosphere requirement if all surfaces are subsequently machined to remove decarburization, or carburization, or intergranular attack from salt, if used. The annealing without atmosphere is subject to G.E. LFP Engineering review.
  - c) Anneal as in IV-A, 1-b.

**B. Castings**

The cast hub shall be homogenized and solution annealed per AMS 5598A by the casting vendor. In process anneals are not anticipated and will require G.E. LFP Engineering approval if deemed necessary by vendor.

REVISIONS
1-5-71 S. P. S. 1-5-71 1-5-72 S. P. S. 1-5-72 1-5-73 S. P. S. 1-5-73 1-5-74 S. P. S. 1-5-74 1-5-75 S. P. S. 1-5-75 1-5-76 S. P. S. 1-5-76 1-5-77 S. P. S. 1-5-77 1-5-78 S. P. S. 1-5-78 1-5-79 S. P. S. 1-5-79 1-5-80 S. P. S. 1-5-80 1-5-81 S. P. S. 1-5-81 1-5-82 S. P. S. 1-5-82 1-5-83 S. P. S. 1-5-83 1-5-84 S. P. S. 1-5-84 1-5-85 S. P. S. 1-5-85 1-5-86 S. P. S. 1-5-86 1-5-87 S. P. S. 1-5-87 1-5-88 S. P. S. 1-5-88 1-5-89 S. P. S. 1-5-89 1-5-90 S. P. S. 1-5-90 1-5-91 S. P. S. 1-5-91 1-5-92 S. P. S. 1-5-92 1-5-93 S. P. S. 1-5-93 1-5-94 S. P. S. 1-5-94 1-5-95 S. P. S. 1-5-95 1-5-96 S. P. S. 1-5-96 1-5-97 S. P. S. 1-5-97 1-5-98 S. P. S. 1-5-98 1-5-99 S. P. S. 1-5-99 1-6-00 S. P. S. 1-6-00

10Z
MAC
161
53
24 <sup>2</sup>
38
PRINTS TO

MADE BY W.M. GARCIA 5-13-63	APPROVALS G.W. 5-11-63	AETD	DIV OR DEPT	A-4012154-969
DESIGNED BY H.L. HOYT / JUNE 6, 63	J.C. 5-18-63	EVEN DALE	LOCATION	CONT. ON SHEET 6 SH NO 5

REV NO /	TITLE
A-4012154-969	INSTRUCTIONS LF-2 FRONT FRAME HUB & STRUT
CONT ON SHEET 7 SH NO 6	FIRST MADE FOR

C. Final Assembly

- (1) Prior to heat treating the assembly is to be thoroughly cleaned without leaving a residue.
- (2) Thermocouples, properly calibrated, with correction factors noted shall be located at the hub, at the center of the strut on the leading and/or trailing edge and at the scroll mount at the end of the strut.
- (3) The part thermocouples shall not exceed a 10°F spread during the aging cycle.
- (4) The final assembly shall be aged as follows:
  - a) Heat to 1025°F and begin one (1) hour age cycle when lowest part thermocouple reads 1015°F.
  - b) Heating to 1025°F is not considered critical however, shelving to equalize thermocouples if required shall be below 800°F.
  - c) Cooling after age is not critical however, furnace cool is not permitted. Slow air cool is permissible.

REVISIONS

1	11/21/63	SEP 25 63	154-969-1

102
MAC
161
53
242
38

PRINTS TO

W.H. GARCIA 5/13/63	APPROVALS G.W. S-1963	AETD	DIV OR DEPT	A-4012154-969
H.L. HOYT / JUNE 6, 1963	J.C. S-1963	EVENDALE	LOCATION	CONT ON SHEET 7 SH NO 6

PP 601 WA (6-63)  
PRINTED IN U.S.A.

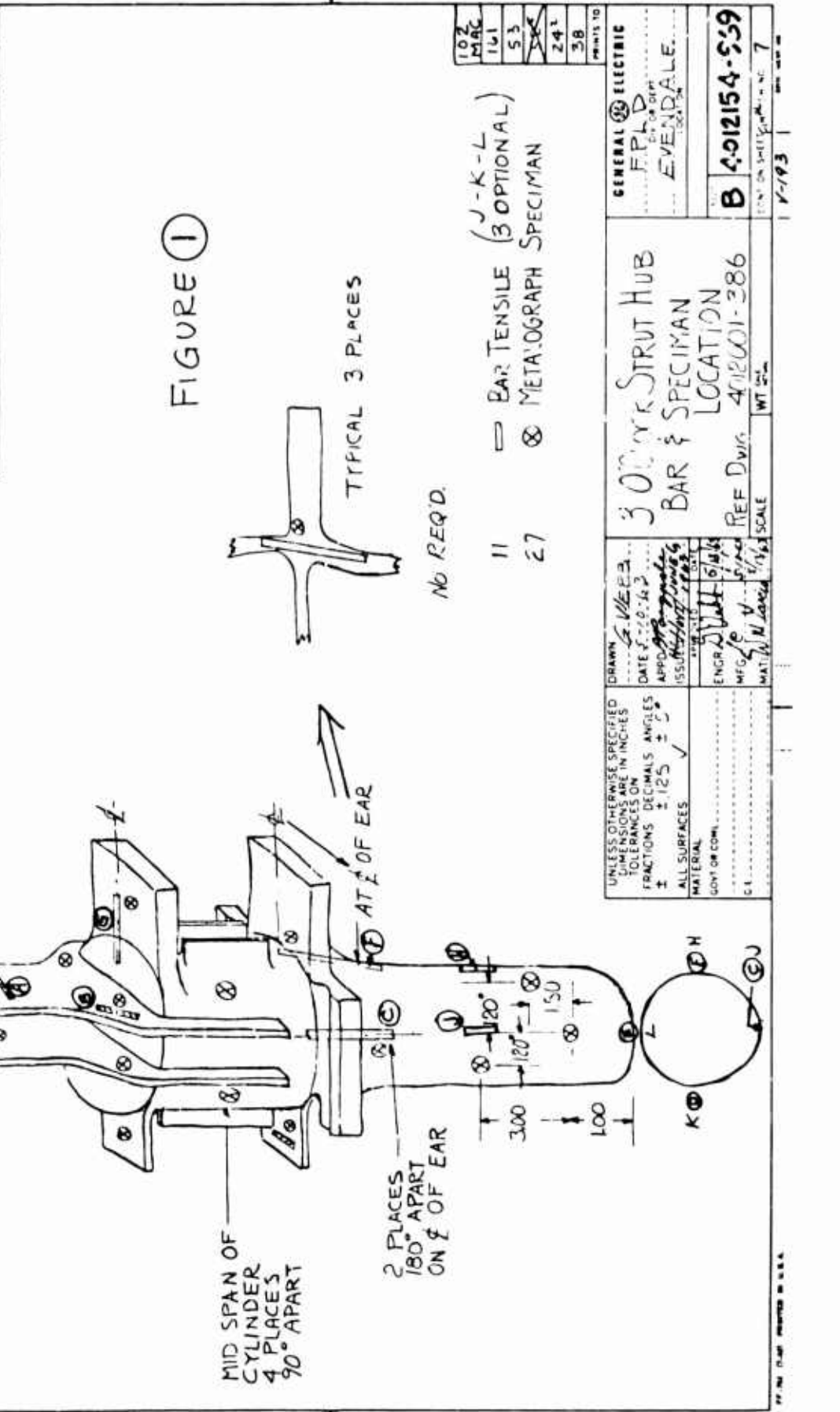
M90

V-193

CODE IDENT NO

REV. 1	DATE 5/27/58	APPROVAL
REV. 2	DATE 5/27/58	APPROVAL
REV. 3	DATE 5/27/58	APPROVAL
REV. 4	DATE 5/27/58	APPROVAL
REV. 5	DATE 5/27/58	APPROVAL
REV. 6	DATE 5/27/58	APPROVAL
REV. 7	DATE 5/27/58	APPROVAL
REV. 8	DATE 5/27/58	APPROVAL
REV. 9	DATE 5/27/58	APPROVAL
REV. 10	DATE 5/27/58	APPROVAL

REV. 1	DATE 5/27/58	APPROVAL
REV. 2	DATE 5/27/58	APPROVAL
REV. 3	DATE 5/27/58	APPROVAL
REV. 4	DATE 5/27/58	APPROVAL
REV. 5	DATE 5/27/58	APPROVAL
REV. 6	DATE 5/27/58	APPROVAL
REV. 7	DATE 5/27/58	APPROVAL
REV. 8	DATE 5/27/58	APPROVAL
REV. 9	DATE 5/27/58	APPROVAL
REV. 10	DATE 5/27/58	APPROVAL



102	MAC	GENERAL ELECTRIC
161		F.P.L.D.
53		ON OR DEPT.
241		EVENDALE, ILL.
38		
PRINTS TO		
3000K STRUT HUB BAR & SPECIMAN		
LOCATION 4012154-386		
REF. DIV. 4012001-386		
SCALE		
WT.		
B 4012154-359		
CONT. ON SHEET 7		

UNLESS OTHERWISE SPECIFIED DIMENSIONS ARE IN INCHES TOLERANCES ON FRACTIONS DECIMALS ANGLES ± .125 ± .5

ALL SURFACES MATERIAL GOVT OR COM.

DRAWN G. VEEB DATE 5-20-58 APPROVED BY ISSUED BY ENGR. J. W. H. MFG. DATE 5/27/58 MAT. N. L. SCALE

100% QUAL. CONTROL BY U.S.A.

NO REQ'D.

11 BAR TENSILE (J-K-L) (3 OPTIONAL)

27 METALLOGRAPH SPECIMAN

FIGURE 1

TYPICAL 3 PLACES

3000K STRUT HUB BAR & SPECIMAN

LOCATION 4012001-386

REF. DIV. 4012154-386

SCALE

WT.

B 4012154-359

CONT. ON SHEET 7

100% QUAL. CONTROL BY U.S.A.

NO REQ'D.

11 BAR TENSILE (J-K-L) (3 OPTIONAL)

27 METALLOGRAPH SPECIMAN

FIGURE 1

TYPICAL 3 PLACES

3000K STRUT HUB BAR & SPECIMAN

LOCATION 4012001-386

REF. DIV. 4012154-386

SCALE

WT.

B 4012154-359

CONT. ON SHEET 7

100% QUAL. CONTROL BY U.S.A.

NO REQ'D.

11 BAR TENSILE (J-K-L) (3 OPTIONAL)

27 METALLOGRAPH SPECIMAN

FIGURE 1

TYPICAL 3 PLACES

3000K STRUT HUB BAR & SPECIMAN

LOCATION 4012001-386

REF. DIV. 4012154-386

SCALE

WT.

B 4012154-359

CONT. ON SHEET 7

100% QUAL. CONTROL BY U.S.A.

NO REQ'D.

11 BAR TENSILE (J-K-L) (3 OPTIONAL)

27 METALLOGRAPH SPECIMAN

FIGURE 1

TYPICAL 3 PLACES

3000K STRUT HUB BAR & SPECIMAN

LOCATION 4012001-386

REF. DIV. 4012154-386

SCALE

WT.

B 4012154-359

CONT. ON SHEET 7

100% QUAL. CONTROL BY U.S.A.

NO REQ'D.

11 BAR TENSILE (J-K-L) (3 OPTIONAL)

27 METALLOGRAPH SPECIMAN

FIGURE 1

TYPICAL 3 PLACES

3000K STRUT HUB BAR & SPECIMAN

LOCATION 4012001-386

REF. DIV. 4012154-386

SCALE

WT.

B 4012154-359

CONT. ON SHEET 7

100% QUAL. CONTROL BY U.S.A.

NO REQ'D.

11 BAR TENSILE (J-K-L) (3 OPTIONAL)

27 METALLOGRAPH SPECIMAN

FIGURE 1

TYPICAL 3 PLACES

3000K STRUT HUB BAR & SPECIMAN

LOCATION 4012001-386

REF. DIV. 4012154-386

SCALE

WT.

B 4012154-359

CONT. ON SHEET 7

100% QUAL. CONTROL BY U.S.A.

NO REQ'D.

11 BAR TENSILE (J-K-L) (3 OPTIONAL)

27 METALLOGRAPH SPECIMAN

FIGURE 1

TYPICAL 3 PLACES

3000K STRUT HUB BAR & SPECIMAN

LOCATION 4012001-386

REF. DIV. 4012154-386

SCALE

WT.

B 4012154-359

CONT. ON SHEET 7

100% QUAL. CONTROL BY U.S.A.

NO REQ'D.

11 BAR TENSILE (J-K-L) (3 OPTIONAL)

27 METALLOGRAPH SPECIMAN

FIGURE 1

TYPICAL 3 PLACES

3000K STRUT HUB BAR & SPECIMAN

LOCATION 4012001-386

REF. DIV. 4012154-386

SCALE

WT.

B 4012154-359

CONT. ON SHEET 7

100% QUAL. CONTROL BY U.S.A.

NO REQ'D.

11 BAR TENSILE (J-K-L) (3 OPTIONAL)

27 METALLOGRAPH SPECIMAN

FIGURE 1

TYPICAL 3 PLACES

3000K STRUT HUB BAR & SPECIMAN

LOCATION 4012001-386

REF. DIV. 4012154-386

SCALE

WT.

B 4012154-359

CONT. ON SHEET 7

100% QUAL. CONTROL BY U.S.A.

NO REQ'D.

11 BAR TENSILE (J-K-L) (3 OPTIONAL)

27 METALLOGRAPH SPECIMAN

FIGURE 1

TYPICAL 3 PLACES

3000K STRUT HUB BAR & SPECIMAN

LOCATION 4012001-386

REF. DIV. 4012154-386

SCALE

WT.

B 4012154-359

CONT. ON SHEET 7

100% QUAL. CONTROL BY U.S.A.

NO REQ'D.

11 BAR TENSILE (J-K-L) (3 OPTIONAL)

27 METALLOGRAPH SPECIMAN

FIGURE 1

TYPICAL 3 PLACES

3000K STRUT HUB BAR & SPECIMAN

LOCATION 4012001-386

REF. DIV. 4012154-386

SCALE

WT.

B 4012154-359

CONT. ON SHEET 7

100% QUAL. CONTROL BY U.S.A.

NO REQ'D.

11 BAR TENSILE (J-K-L) (3 OPTIONAL)

27 METALLOGRAPH SPECIMAN

FIGURE 1

TYPICAL 3 PLACES

3000K STRUT HUB BAR & SPECIMAN

LOCATION 4012001-386

REF. DIV. 4012154-386

SCALE

WT.

B 4012154-359

CONT. ON SHEET 7

100% QUAL. CONTROL BY U.S.A.

NO REQ'D.

11 BAR TENSILE (J-K-L) (3 OPTIONAL)

27 METALLOGRAPH SPECIMAN

FIGURE 1

TYPICAL 3 PLACES

3000K STRUT HUB BAR & SPECIMAN

LOCATION 4012001-386

REF. DIV. 4012154-386

SCALE

WT.

B 4012154-359

CONT. ON SHEET 7

100% QUAL. CONTROL BY U.S.A.

NO REQ'D.

11 BAR TENSILE (J-K-L) (3 OPTIONAL)

27 METALLOGRAPH SPECIMAN

FIGURE 1

TYPICAL 3 PLACES

3000K STRUT HUB BAR & SPECIMAN

LOCATION 4012001-386

REF. DIV. 4012154-386

SCALE

WT.

B 4012154-359

CONT. ON SHEET 7

100% QUAL. CONTROL BY U.S.A.

NO REQ'D.

11 BAR TENSILE (J-K-L) (3 OPTIONAL)

27 METALLOGRAPH SPECIMAN

FIGURE 1

TYPICAL 3 PLACES

3000K STRUT HUB BAR & SPECIMAN

LOCATION 4012001-386

REF. DIV. 4012154-386

SCALE

WT.

B 4012154-359

CONT. ON SHEET 7

100% QUAL. CONTROL BY U.S.A.

NO REQ'D.

11 BAR TENSILE (J-K-L) (3 OPTIONAL)

27 METALLOGRAPH SPECIMAN

FIGURE 1

TYPICAL 3 PLACES

3000K STRUT HUB BAR & SPECIMAN

LOCATION 4012001-386

REF. DIV. 4012154-386

SCALE

WT.

B 4012154-359

CONT. ON SHEET 7

100% QUAL. CONTROL BY U.S.A.

NO REQ'D.

11 BAR TENSILE (J-K-L) (3 OPTIONAL)

27 METALLOGRAPH SPECIMAN

FIGURE 1

TYPICAL 3 PLACES

3000K STRUT HUB BAR & SPECIMAN

LOCATION 4012001-386

REF. DIV. 4012154-386

SCALE

WT.

B 4012154-359

CONT. ON SHEET 7

100% QUAL. CONTROL BY U.S.A.

NO REQ'D.

11 BAR TENSILE (J-K-L) (3 OPTIONAL)

27 METALLOGRAPH SPECIMAN

FIGURE 1

TYPICAL 3 PLACES

3000K STRUT HUB BAR & SPECIMAN

LOCATION 4012001-386

REF. DIV. 4012154-386

SCALE

WT.

B 4012154-

Unclassified

Security Classification

DOCUMENT CONTROL DATA - R&D		
<i>(Security classification of title, body of abstract and indexing annotation must be entered when the overall report is classified)</i>		
1. ORIGINATING ACTIVITY (Corporate author) General Electric Company Cincinnati, Ohio 45215		2a. REPORT SECURITY CLASSIFICATION Unclassified
		2b. GROUP
3. REPORT TITLE LF-2 Lightweight Lift Fan Front Frame Design		
4. DESCRIPTIVE NOTES (Type of report and inclusive dates) Final		
5. AUTHOR(S) (Last name, first name, initial)		
6. REPORT DATE May 1966	7a. TOTAL NO. OF PAGES 140	7b. NO. OF REFS
8a. CONTRACT OR GRANT NO. DA 44-177-AMC-45(T)	9a. ORIGINATOR'S REPORT NUMBER(S) USAAVLABS Technical Report 66-12	
b. PROJECT NO. Task 1M121401D14409	9b. OTHER REPORT NO(S) (Any other numbers that may be assigned this report)	
c.		
d.		
10. AVAILABILITY/LIMITATION NOTICES Distribution of this document is unlimited.		
11. SUPPLEMENTARY NOTES	12. SPONSORING MILITARY ACTIVITY US Army Aviation Materiel Laboratories Fort Eustis, Virginia	
13. ABSTRACT The design, the manufacturing problems and their solutions, and the limited testing of a new bolted component assembled lightweight front frame for a tip turbine lift fan are discussed. This new frame was necessary for compatibility with a new lightweight improved critical speed response rotor design and to replace the present X353-5B front frame which is used in the General Electric Company's XV-5A Lift Fan Flight Research Program with a lighter weight and lower cost unit.  The functions, description, design considerations, and stresses are discussed for each component.  The frame component weights as calculated have been tabulated, and a comparison of the summation of the component calculated weights of 99.6 pounds versus the actual pan weight of 103 pounds is discussed.  The frame was tested to 100-percent rotor speed loading as a component part of the LF-2 lift fan assembly. Limited operating data were obtained because of test termination resulting from turbine bucket shroud damage.		

DD FORM 1473  
1 JAN 64

Unclassified  
Security Classification

14. KEY WORDS	LINK A		LINK B		LINK C	
	ROLE	WT	ROLE	WT	ROLE	WT

INSTRUCTIONS

1. **ORIGINATING ACTIVITY:** Enter the name and address of the contractor, subcontractor, grantee, Department of Defense activity or other organization (*corporate author*) issuing the report.
- 2a. **REPORT SECURITY CLASSIFICATION:** Enter the overall security classification of the report. Indicate whether "Restricted Data" is included. Marking is to be in accordance with appropriate security regulations.
- 2b. **GROUP:** Automatic downgrading is specified in DoD Directive 5200.10 and Armed Forces Industrial Manual. Enter the group number. Also, when applicable, show that optional markings have been used for Group 3 and Group 4 as authorized.
3. **REPORT TITLE:** Enter the complete report title in all capital letters. Titles in all cases should be unclassified. If a meaningful title cannot be selected without classification, show title classification in all capitals in parenthesis immediately following the title.
4. **DESCRIPTIVE NOTES:** If appropriate, enter the type of report, e.g., interim, progress, summary, annual, or final. Give the inclusive dates when a specific reporting period is covered.
5. **AUTHOR(S):** Enter the name(s) of author(s) as shown on or in the report. Enter last name, first name, middle initial. If military, show rank and branch of service. The name of the principal author is an absolute minimum requirement.
6. **REPORT DATE:** Enter the date of the report as day, month, year, or month, year. If more than one date appears on the report, use date of publication.
- 7a. **TOTAL NUMBER OF PAGES:** The total page count should follow normal pagination procedures, i.e., enter the number of pages containing information.
- 7b. **NUMBER OF REFERENCES:** Enter the total number of references cited in the report.
- 8a. **CONTRACT OR GRANT NUMBER:** If appropriate, enter the applicable number of the contract or grant under which the report was written.
- 8b, 8c, & 8d. **PROJECT NUMBER:** Enter the appropriate military department identification, such as project number, subproject number, system numbers, task number, etc.
- 9a. **ORIGINATOR'S REPORT NUMBER(S):** Enter the official report number by which the document will be identified and controlled by the originating activity. This number must be unique to this report.
- 9b. **OTHER REPORT NUMBER(S):** If the report has been assigned any other report numbers (*either by the originator or by the sponsor*), also enter this number(s).

10. **AVAILABILITY/LIMITATION NOTICES:** Enter any limitations on further dissemination of the report, other than those imposed by security classification, using standard statements such as:

- (1) "Qualified requesters may obtain copies of this report from DDC."
- (2) "Foreign announcement and dissemination of this report by DDC is not authorized."
- (3) "U. S. Government agencies may obtain copies of this report directly from DDC. Other qualified DDC users shall request through \_\_\_\_\_."
- (4) "U. S. military agencies may obtain copies of this report directly from DDC. Other qualified users shall request through \_\_\_\_\_."
- (5) "All distribution of this report is controlled. Qualified DDC users shall request through \_\_\_\_\_."

If the report has been furnished to the Office of Technical Services, Department of Commerce, for sale to the public, indicate this fact and enter the price, if known.

11. **SUPPLEMENTARY NOTES:** Use for additional explanatory notes.
12. **SPONSORING MILITARY ACTIVITY:** Enter the name of the departmental project office or laboratory sponsoring (*paying for*) the research and development. Include address.
13. **ABSTRACT:** Enter an abstract giving a brief and factual summary of the document indicative of the report, even though it may also appear elsewhere in the body of the technical report. If additional space is required, a continuation sheet shall be attached.

It is highly desirable that the abstract of classified reports be unclassified. Each paragraph of the abstract shall end with an indication of the military security classification of the information in the paragraph, represented as (TS), (S), (C), or (U).

There is no limitation on the length of the abstract. However, the suggested length is from 150 to 225 words.

14. **KEY WORDS:** Key words are technically meaningful terms or short phrases that characterize a report and may be used as index entries for cataloging the report. Key words must be selected so that no security classification is required. Identifiers, such as equipment model designation, trade name, military project code name, geographic location, may be used as key words but will be followed by an indication of technical context. The assignment of links, rules, and weights is optional.