

AD 68 1525

AD

USAAVLABS TECHNICAL REPORT 66-23

DESIGN STUDY AND FABRICATION OF TWO INTERCHANGEABLE UH-1 AIRCREW ARMOR SYSTEMS

Final Report

By

D. Fernandez
H. W. Sheldon

April 1966

D D C
RECEIVED
APR 1966

U. S. ARMY AVIATION MATERIEL LABORATORIES

FORT EUSTIS, VIRGINIA

CONTRACT DA 44-177-AMC-224(T)

AEROJET-GENERAL CORPORATION

AZUSA, CALIFORNIA

Distribution of this document is unlimited.



CLEARINGHOUSE FOR FEDERAL SCIENTIFIC AND TECHNICAL INFORMATION			
Hardcopy	Microfiche	52	1/2
\$ 2.00	\$.50	PP	
ARCHIVE COPY			

Disclaimers

The findings in this report are not to be construed as an official Department of the Army position unless so designated by other authorized documents.

When Government drawings, specifications, or other data are used for any purpose other than in connection with a definitely related Government procurement operation, the United States Government thereby incurs no responsibility nor any obligation whatsoever; and the fact that the Government may have formulated, furnished, or in any way supplied the said drawings, specifications, or other data is not to be regarded by implication or otherwise as in any manner licensing the holder or any other person or corporation, or conveying any rights or permission, to manufacture, use, or sell any patented invention that may in any way be related thereto.

Trade names cited in this report do not constitute an official endorsement or approval of the use of such commercial hardware or software.

Disposition Instructions

Destroy this report when no longer needed. Do not return it to originator.

ACCPSSION FOR	
CFSTI	WHITE SECTION <input checked="" type="checkbox"/>
DOC	BUFF SECTION <input type="checkbox"/>
IS ANNOUNCED	<input type="checkbox"/>
JUSTIFICATION	<i>fully justified</i>
1473	
DISTR BUTION/AVAILABILITY CODES	
DIST.	AVAIL. and/or SPECIAL
1	

ND

12



DEPARTMENT OF THE ARMY
U. S. ARMY AVIATION MATERIEL LABORATORIES
FORT EUSTIS, VIRGINIA 23604

This report has been prepared by the Aerojet-General Corporation under the terms of Contract DA 44-177-AMC-224(T). It consists of a discussion of the criteria established and the approach followed to design and fabricate a personnel protective armor system for the crew members of a UH-1 aircraft. The unique feature of the armor system is its capability of offering either .30- or .50-caliber ballistic protection through the use of interchangeable armor components.

The object of this contractual effort was to seek original and unique design techniques and fabrication efforts which would provide adequate ballistic protection against either .30- or .50-caliber projectiles through the means of interchangeable armor components with minimum weight penalties.

In general, it can be stated that the design solution presented in the report is a possible approach, provided that the aircraft can accept the associated weight penalties.

The conclusions and recommendations contained herein are concurred in by this command. This concurrence does not imply the practicality or endorsement of the use of such a system specifically for a UH-1 aircraft. However, it is believed that the principle of interchangeable armor panels to provide varying levels of ballistic protection for Army aircraft is technically feasible.

Task 1P121401A1500301
Contract DA 44-177-AMC-224(T)
USAAVLABS Technical Report 66-23
April 1966

DESIGN STUDY AND FABRICATION OF TWO INTERCHANGEABLE
UH-1 AIRCREW ARMOR SYSTEMS

Final Report
(AGC Report No. 2950)

by

D. Fernandez
H. W. Sheldon

Prepared by

Aerojet-General Corporation
Azusa, California

for

U.S. ARMY AVIATION MATERIEL LABORATORIES
FORT EUSTIS, VIRGINIA

*Distribution of this
document is unlimited.*

ABSTRACT

The design and evaluation of two interchangeable UH-1 aircrew armor systems capable of defeating 7.62mm, .30-caliber, and .50-caliber AP ammunition are described. The design features of the systems are described, and a structural analysis of the system is presented.

CONTENTS

	<u>Page</u>
ABSTRACT	iii
PREFACE	v
LIST OF ILLUSTRATIONS	viii
LIST OF SYMBOLS	ix
SUMMARY	1
CONCLUSIONS AND RECOMMENDATIONS	2
DISCUSSION	3
Objective	3
Design Requirements	3
Design	4
Ballistic Considerations and Coverage	8
Weight and Center-of-Gravity Analysis	9
Structural Analysis	9
DISTRIBUTION	40

CONTENTS

	<u>Page</u>
ABSTRACT	iii
PREFACE	v
LIST OF ILLUSTRATIONS	viii
LIST OF SYMBOLS	ix
SUMMARY	1
CONCLUSIONS AND RECOMMENDATIONS	2
DISCUSSION	3
Objective	3
Design Requirements	3
Design	4
Ballistic Considerations and Coverage	8
Weight and Center-of-Gravity Analysis	9
Structural Analysis	9
DISTRIBUTION	40

PREFACE

This report was prepared by the Chemical and Structural Products Division of Aerojet-General Corporation, Azusa, California, under U.S. Army Contract DA 44-177-AMC-224(T). The work was conducted under the direction of the U.S. Army Aviation Materiel Laboratories. The technical representatives for the Army were Messrs. J. L. Reed and R. G. Porter.

This report covers work performed between 21 July 1964 and 2 August 1965.

Mr. D. Fernandez was Program Manager and Mr. H. W. Sheldon was Project Engineer.

SYMBOLS

A_s	shear tear-out area - in. ²
A_{z_u}	vertical acceleration - g
A_{y_u}	fore and aft acceleration - g
A_{x_u}	lateral acceleration - g
a	distance from impact point to test panel support point - in.
b	width of panel at support point - in.
E	modulus of elasticity - psi
F_{tu}	ultimate tensile strength - psi
I	moment of inertia - in. ⁴
K	elastic energy loss factor
K'	tile fracture and local elasto-plastic energy loss factor
L	length - in.
M	bending moment - in.-lb
M.S.	margin of safety
M_{cr}	critical bending moment - in.-lb
N_z	ultimate vertical load factor - g
N_y	ultimate fore and aft load factor - g
N_x	ultimate lateral load factor - g
P_c	axial load - lb
P_s	applied shear load - lb
P_z	vertical flight acceleration load - lb
P_x	fore and aft flight acceleration load - lb
P_y	lateral flight acceleration load - lb
R_o	outside radius - in.
R_i	inside radius - in.
V_1	velocity of projectile at impact - in./sec
W_b	weight of tile-plate armor system - lb
W_s	weight of seat - lb
W_p	weight of pilot - lb
χ	point of maximum bending moment - in.
δ_a	measured impact deflection - in.

δ_i impact deflection - in.
 δ_s static deflection - in.
 σ_i impact stress - psi
 σ_s static stress - psi
j radius of gyration - in.

SUMMARY

Army aircraft and personnel engaged in combat operations in Southeast Asia are often exposed to small-arms (.30-caliber, .50-caliber, and 7.62mm projectiles) ground fire. In order to combat this threat, aircrew armor systems have been developed. Present airmobile assault operations are encountering increasing levels of heavier caliber machine gun and antiaircraft weapon fire. The purpose of this project is to design and fabricate an improved UH-1 aircrew armor system capable of meeting this intensified threat, up to .50-caliber armor-piercing projectiles.

A seat configuration was developed by employing proven principles of human engineering design and using the armor panels as structural members of the assembly.

The system was designed in a kit form using interchangeable armor panels capable of providing protection against .30-caliber and .50-caliber projectiles. The panels are bracketed together, permitting replacement of damaged components and allowing interchangeability of either .30- or .50-caliber individual armor components. This armor system concept may be used in a variety of aircraft. The brackets are specifically designed to attach the kit to the seat frame of a UH-1D and to the seat track of either a UH-1B or a UH-1D helicopter.

The armor selected consists of a ceramic-aluminum system for .30-caliber protection and a ceramic-titanium system for .50-caliber protection. The .30-caliber armor weighs approximately 10.5 pounds per square foot; the .50-caliber armor weighs approximately 18.5 pounds per square foot. Total assembled seat weights are as follows: .30-caliber, 205 pounds; .50-caliber, 330.5 pounds.

Fabrication drawings were prepared, and from these the required hardware was fabricated. The hardware items consist of a .30-caliber armored seat and a .50-caliber armored seat, plus an extra set of .30-caliber armor panels and an extra set of .50-caliber armor panels.

The seats were inspected at Aerojet on 7 July 1965, and the seats plus extra sets were subsequently shipped to Ft. Eustis.

A stress analysis was performed on each of the systems to evaluate the effect of acceleration and ballistic impact loads on the support structure bracketing and armor panels. The results of the stress analysis appear as a portion of this report.

CONCLUSIONS AND RECOMMENDATIONS

It is possible to accommodate a 95-percentile man and provide essentially 100-percent protection to the trunk torso area of this man by use of an armored seat for the UH-1 aircraft. Very limited design compromises are required to achieve a single basic system with interchangeable panels to provide protection against .30-caliber or .50-caliber projectiles and to permit relatively rapid replacement of damaged panels.

The use of the mosaic tile system for the flat panels is both functionally acceptable and relatively straightforward from the fabrication standpoint. The mosaic system is functionally acceptable for the chest protector, but because of the configuration of the protector, fabrication is more difficult than in the case of the flat panels.

The use of single-piece curved tile, possible with fiber-glass-reinforced plastic backing for the chest protector, should be considered in future designs.

As demonstrated on the current UH-1D and UH-1B/D armor programs, sliding outboard shoulder panels rather than the fixed type permit more rapid egress from the aircraft. This feature is recommended for future designs of the UH-1 aircrew systems developed in this program.

DISCUSSION

OBJECTIVE

The objective of this program was to design and evaluate two interchangeable UH-1 aircrew armor systems. One system was to be capable of defeating 7.62mm and .30-caliber AP ammunition. The other system was to have the capability of defeating .50-caliber AP ammunition.

DESIGN REQUIREMENTS

The following technical criteria govern the design of the systems:

1. Ballistic Requirements

- a. One system must be capable of defeating .30-caliber and 7.62mm AP M2 ammunition fired at a 100-yard range and impacting at a 15-degree obliquity.
- b. One system must be capable of defeating .50-caliber AP M2 ammunition fired at a 100-yard range and impacting at a 15-degree obliquity.

2. Configuration

- a. The systems must accommodate a 95-percentile man.
- b. The systems must provide 100-percent protection to the trunk torso area of the 95-percentile man.
- c. The systems must not interfere with operation of the flight controls by either member of the aircrew.
- d. The front torso protection must not rest upon the legs of the wearer.
- e. Each system must be capable of being installed by a maximum of two personnel using a standard military tool kit.
- f. The systems must be designed so that a minimum of modification of the aircraft structures or components is required for installation.
- g. Each respective component within both systems must be interchangeable (i.e., .30-caliber seat bottom must be interchangeable with .50-caliber seat bottom, etc.)

3. Weights and Loads

- a. The maximum allowable areal densities of the armor material are as follows: 10.5 pounds per square foot for the .30-caliber armor, and 20 pounds per square foot for the .50-caliber armor.
- b. Bracketry and supporting hardware must be stressed for the following ultimate load factors:

$$N_z = \pm 7.0g$$

$$N_y = \pm 3.0g$$

$$N_x = \pm 3.0g$$

- c. The design of supporting bracketry for all armor components must incorporate sufficient structural strength to hold each component intact under maximum ballistic shock.

DESIGN

Based on the technical criteria enumerated above, designs were established for the .30-caliber and the .50-caliber systems. In each case, the design represents an engineering balance of the consideration of protected area, function and convenience, comfort, system weight, and ease of installation.

The basic armor system design is shown schematically in Figure 1. For both the .30-caliber and the .50-caliber systems, the armored seat consists of a supporting structure plus a series of panels and a chest plate to provide the required ballistic protection.

Design features for each of the systems are described briefly below.

1. Supporting Structure

The supporting structures for both the .30-caliber and .50-caliber systems consist basically of the A-frame for the current production model of the UH-1D helicopter aircraft seat. The A-frame can be installed on the standard floor mounting tracks of either a UH-1B or -1D aircraft. Basic modifications required for the A-frame were widening of the frame and reinforcement of the structure to sustain the additional loads imposed by the armored shell. Widening of the frame was accomplished by merely extending existing frame members to ensure acceptance by the standard floor mounting tracks. Modifications were not made to the track attachment.

Provision for vertical and horizontal adjustment of the seat for both systems is comparable to the adjustment in the current design. In both systems, horizontal adjustment is identical to the current

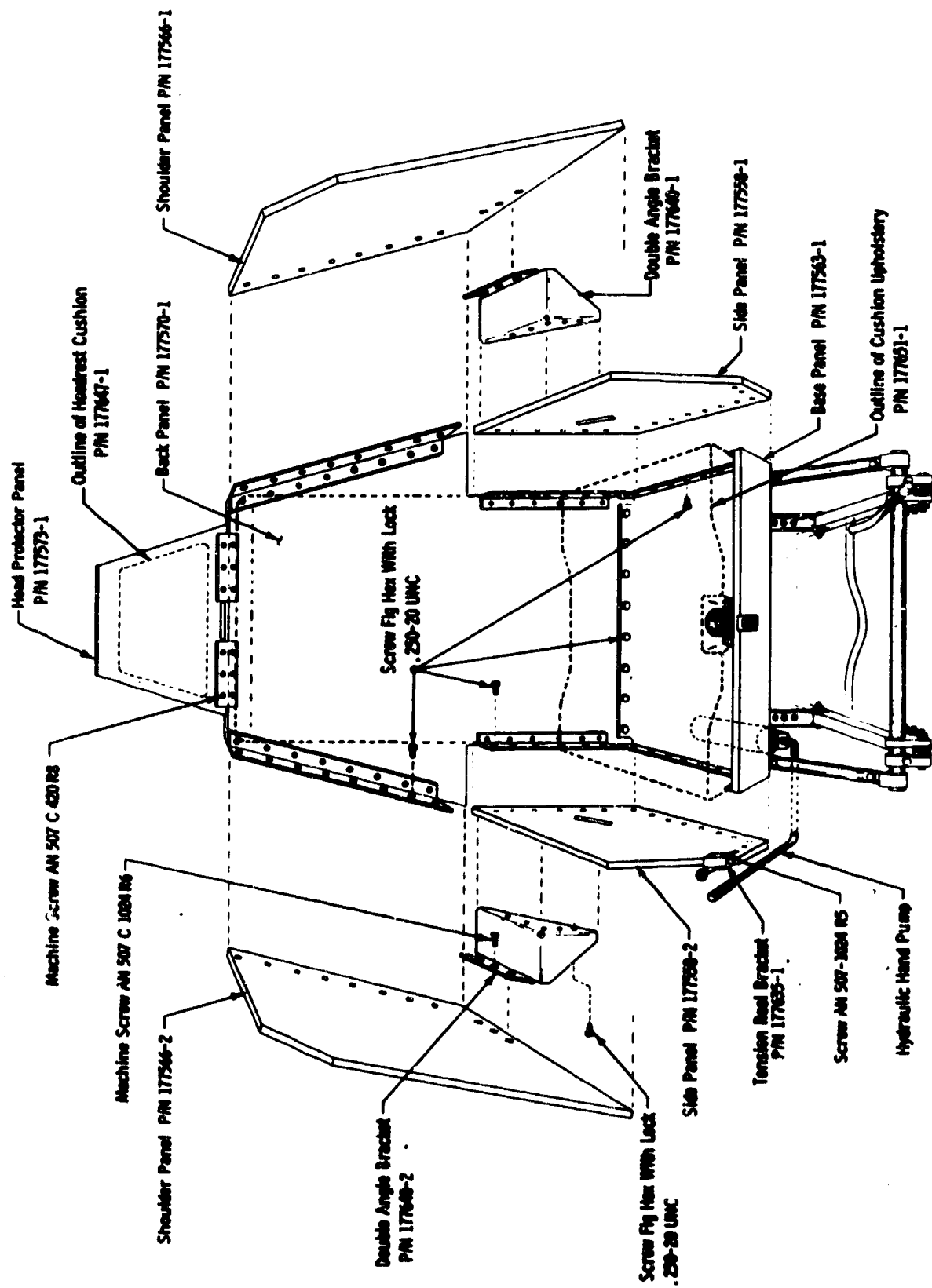

Figure 1. UH-1B Armored Seat Assembly (.50-Caliber System Shown).

design. However, because of the appreciable difference in weight between the .30-caliber and .50-caliber systems, two different methods of accomplishing vertical seat adjustment were evaluated. One design is applicable to the .30-caliber system only. The other design is applicable to either system. However, the design with dual applicability is considerably oversized for the .30-caliber system.

Springs are used to provide the lifting force for the .30-caliber system only. A hydraulic system with a manual pump is used for the .50-caliber system.

Back and bottom panels capable of defeating either .30-caliber or .50-caliber ammunition may be bolted to the supporting structure. Identical hole patterns are provided in the two systems to permit the required interchangeability of panels.

Because the .50-caliber armor system is considerably heavier than the .30-caliber system, additional structural reinforcement of the A-frame is required in addition to the use of the hydraulic lifting device. The reinforcement involves replacement of the lower aft cross member of the A-frame by a member capable of sustaining the loads imposed by the hydraulic cylinder which supports the seat. In addition, the structural X-members which support the armored shell were reinforced and modified to accommodate attachment of the upper end of the hydraulic cylinder.

2. Armor Panels

The armor panels for the two systems are similar in that they consist of ceramic tile facing, an adhesive system, an elastomeric layer to provide decoupling between the tile and the backup plate, and a metal backup plate.

An exploded view of a typical armor panel is shown in Figure 2.

Aluminum angles are riveted to the back and bottom panels to permit mounting and support of the side panels, shoulder panels, and head protector. All panels are drilled and tapped to permit attachment of the bottom and back panels to the supporting structure and to permit attachment of the other panels to the side and back panels as well as to the supporting brackets. Brackets are used to adequately support the shoulder panels.

As indicated above, identical hole patterns are provided in the two systems to permit the required interchangeability of panels.

3. Chest Protectors

The construction of the chest protectors is similar to the construction of the panels in that the chest protectors are metal-backed, alumina tile.

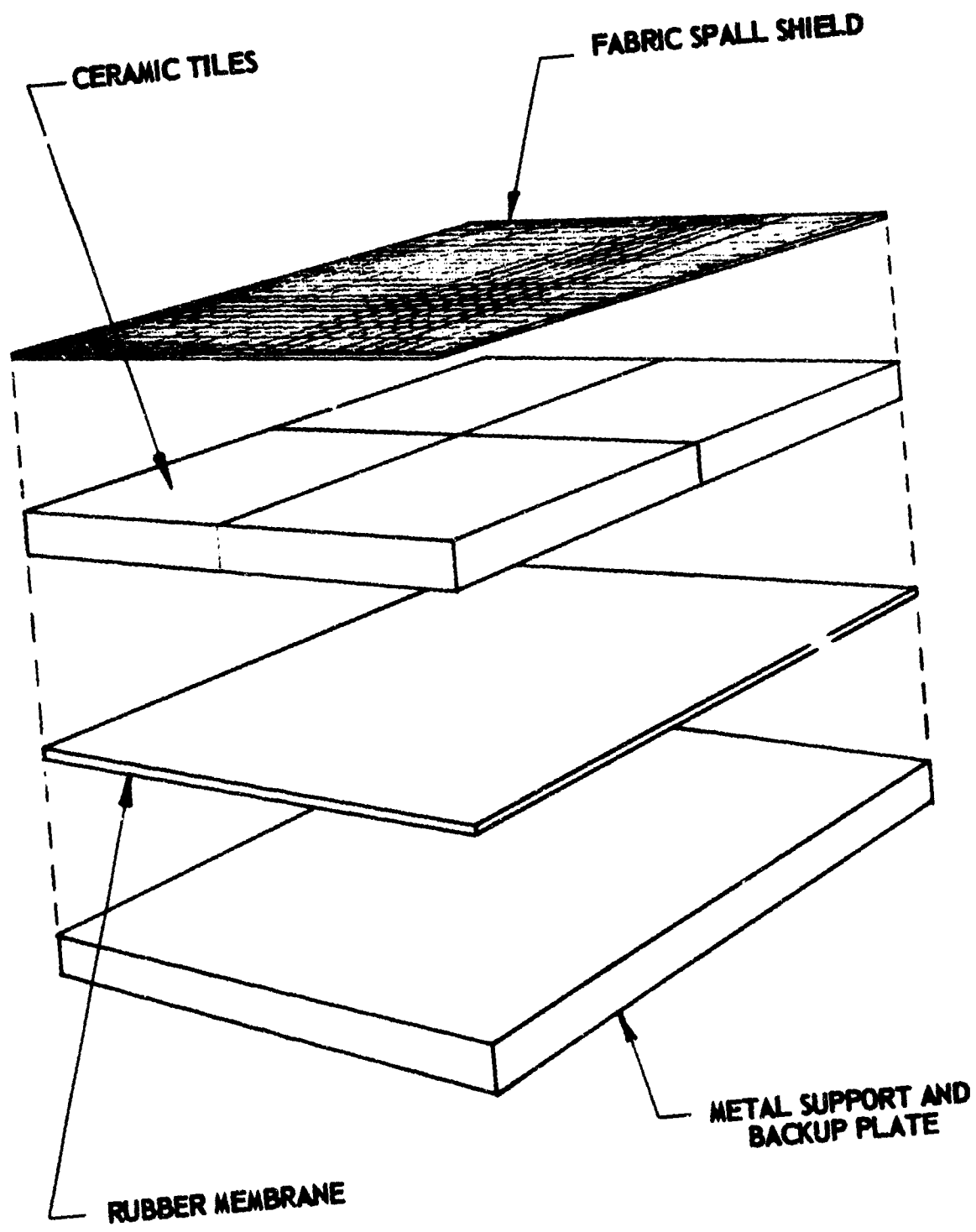

Figure 2. Typical Armor Configuration (Exploded View).

The inner surface of each of the chest protectors is covered with a 0.75-inch-thick rubber pad (Rubatex). This rubber padding has been provided to attenuate ballistic impact forces and to offer a degree of comfort while in use.

The chest protector is supported from the crotch protector extension on the bottom plate. The bottom surface of the protector is supported sufficiently high that it does not rest on the legs of the crew member. The chest protector is held against the crew member's chest by means of two pieces of bungee cord which are fastened near the top of the protector and have a quick-release capability to provide for rapid egress when required. The bungee cord is attached to clips which are bolted to the back plate.

The bottom support for the chest protector is a ball and socket joint. A hardened steel ball is mounted on the base plate. The mating steel part is attached to an armored tab at the bottom of the chest protector. The ball and socket are essentially locked together, except when the chest protector is tilted to the extreme forward position.

The ball and socket concept in combination with the elastic cords at the top allows free movement of the crew member in the seat. Rapid egress is made possible by quick release of the bungee cord clips and a tilting of the chest protector forward so that the ball is released from the socket.

BALLISTIC CONSIDERATIONS AND COVERAGE

1. Ballistic Considerations

The .30-caliber armor must be capable of protection against .30-caliber and 7.62mm AP M2 ammunition fired at a 100-yard range and a 15-degree obliquity. The .50-caliber armor must be capable of providing protection against .50-caliber AP M2 ammunition fired at a 100-yard range and impacting at a 15-degree obliquity.

The selection of the armor material for the two systems was made on the basis of past experience as well as testing by Aerojet and others. Metal backup was used rather than fiber-glass-reinforced plastic backup because of structural support and attachment advantages. Single-tile test specimens of .30 caliber and .50 caliber were fabricated and subjected to ballistic impact. The specimens defeated the .30-caliber and .50-caliber projectiles when they were fired at a distance of 100 yards and impacted at an angle of 15 degrees relative to the test specimen.

2. Coverage

The systems must provide 100-percent protection for the trunk torso region of the 95-percentile man.

Protection afforded by the seat and chest protector is shown in Figure 3. It may be noted from the illustration that full protection of the trunk torso area is provided. Crotch protection is provided by the integral angled extension at the forward end of the bottom plate. The chest protector provides the fullest protection possible without seriously restricting movement of the aircrew member in the seat. In addition, the top trapezoidal-shaped panel provides protection for the head against ammunition fired from the rear (Figure 4). Side protection is shown in Figure 5.

WEIGHT AND CENTER-OF-GRAVITY ANALYSIS

Areal densities of the armor materials must not exceed 10.5 pounds per square foot for the .30-caliber armor and 20 pounds per square foot for the .50-caliber armor. (These weights include the spall shield, bonding resins, and other components of the armor.)

No total weight was specified for either armor system. However, each system must be capable of being installed by a maximum of two men. No center-of-gravity (cg) requirement was defined for the systems. However, a cg determination for each system was required.

1. Weight

The average areal density of the .30-caliber armor fabricated in this program is 10.5 pounds per square foot. The average areal density of the .50-caliber armor is 18.5 pounds per square foot. The weight of each panel is shown on Figures 6 and 7.

The total weight of the .30-caliber seat and chest protector is 205 pounds. The total weight of the .50-caliber seat and chest protector is 330.5 pounds. Each of the seats can be lifted and installed in the aircraft by two men, if necessary.

2. Center of Gravity

The location of the center of gravity for each system is shown on Figures 6 and 7.

STRUCTURAL ANALYSIS

1. Introduction

The structural design of the UH-1B helicopter armored seat was based upon two requirements: (a) the capability to resist ballistic impact loads and (b) the ability to sustain loads imposed during acceleration of the aircraft. Two geometrically similar designs were developed with the capability of resisting penetration by .30-caliber and .50-caliber armor-piercing projectiles when fired at a 100-yard range and a 15-degree obliquity.



Figure 3. Front View of Armored Seat Showing Coverage Afforded a 95-Percentile Man.

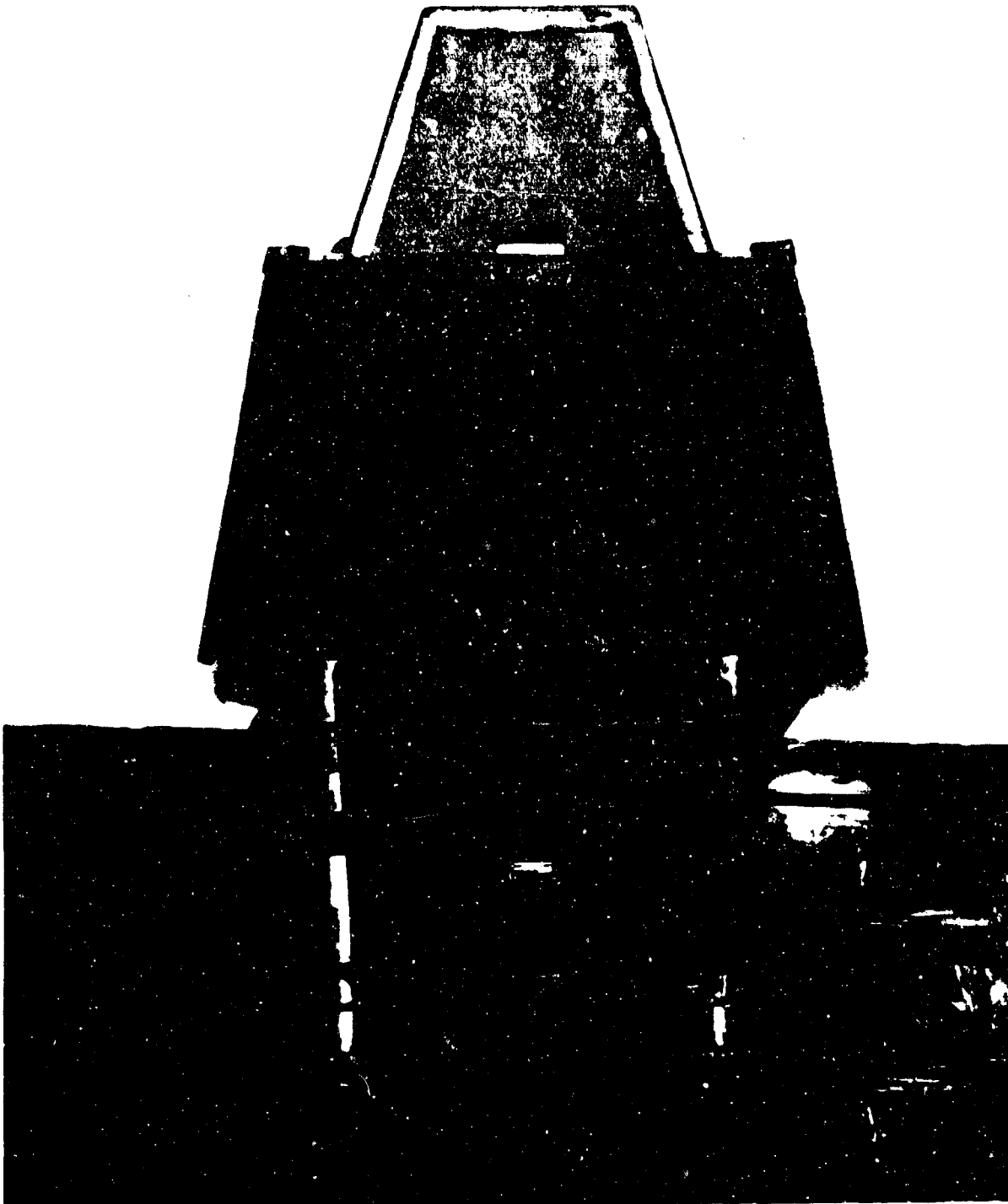

Figure 4. Back View of Armored Seat.



Figure 5. Side View of Armored Seat.

ITEM NO	NAME	UNIT WT (LB)	NO REQD	TOTAL WT (LB)
1	BOTTOM PANEL	24.40	1	24.40
2	BACK PANEL	47.10	1	47.10
3	SHOULDER PANEL	20.00	2	40.00
4	SIDE PANEL	15.23	2	30.46
5	HEAD PROTECTOR PANEL WITH BRACKETS	8.50	1	8.50
6	BRACKET, SHOULDER PANEL	.62	2	1.24
7	CHEST PROTECTOR	23.50	1	23.50
8	SEAT CUSHIONS (SET)	3.80	1 Set	3.80
9	FRAME-STRUCTURAL SUPPORT	26.00	1	26.00
	TOTAL			205.00

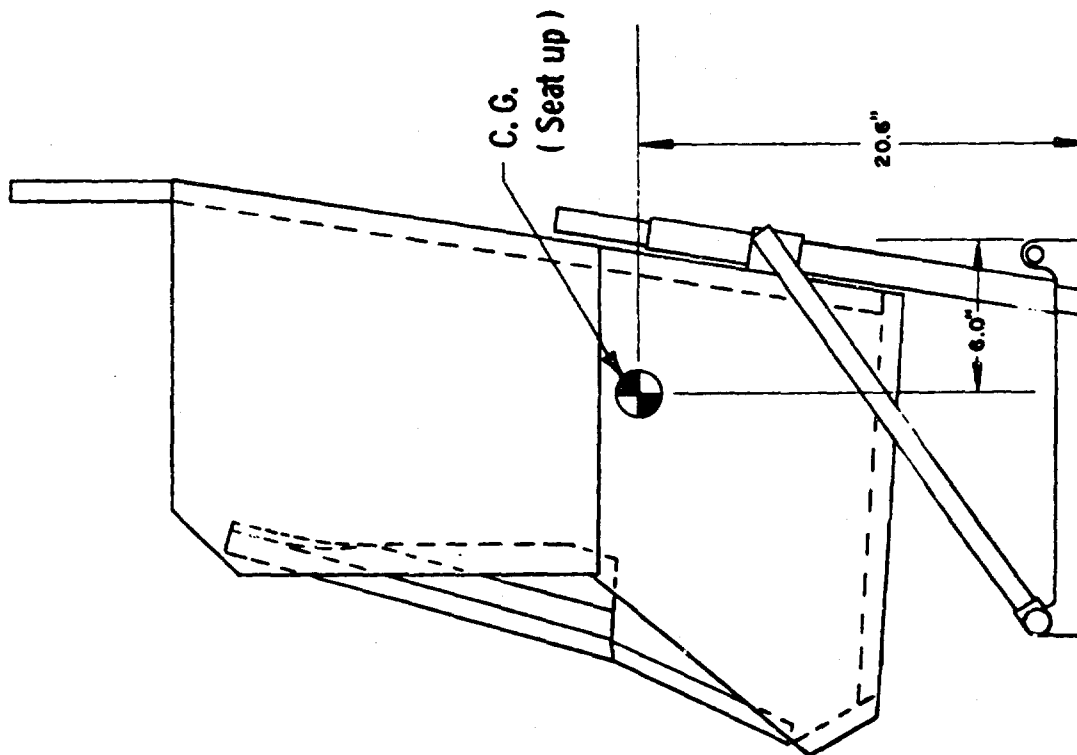

Figure 6. Weight of UH-1B Armored Seat, .30-Caliber System, and Center of Gravity.

Figure 6. Weight of UH-1B Armored Seat, .30-Caliber System, and Center of Gravity.

ITEM NO	NAME	UNIT WT (LB)	NO REQD	TOTAL WT (LB)
1	BOTTOM PANEL	40.23	1	40.23
2	BACK PANEL	73.50	1	73.50
3	SHOULDER PANEL	33.27	2	66.54
4	SIDE PANEL	25.28	2	50.56
5	BRACKET-SHOULDER PANEL	.62	2	1.24
6	HEAD PROTECTOR PANEL WITH BRACKETS	13.82	1	13.82
7	CHEST PROTECTOR	37.25	1	37.25
8	PUMP, HYDRAULIC	5.85	1	5.85
9	SEAT CUSHIONS (SET)	3.75	1 Set	3.75
10	FRAME, STRUCTURAL SUPPORT	37.76	1	37.76
	TOTAL			330.50

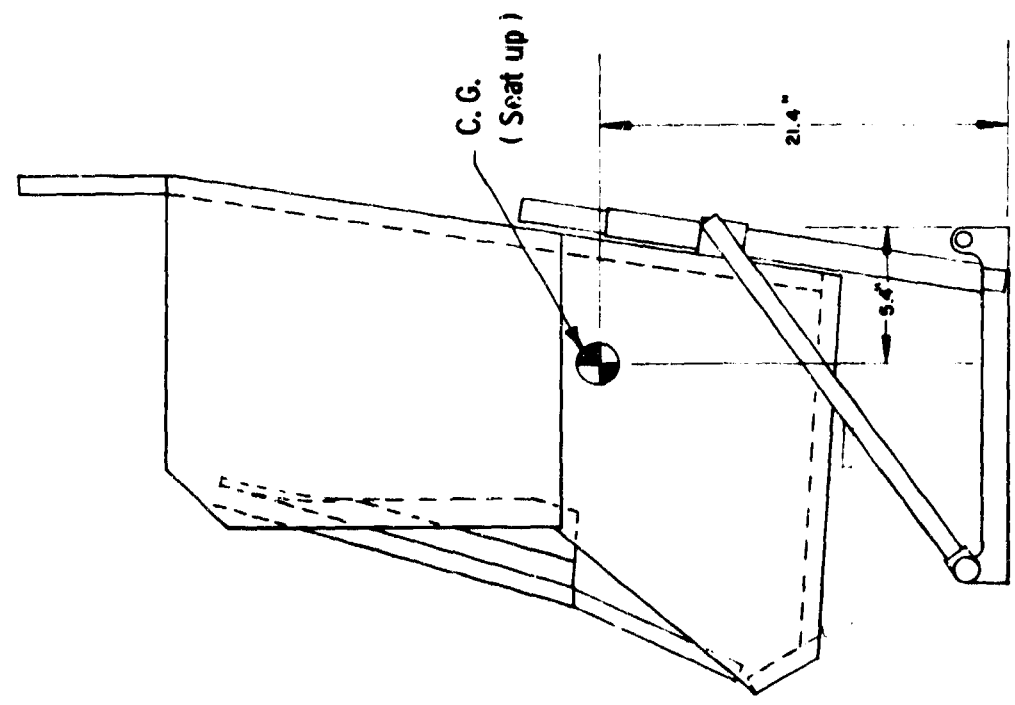

Figure 7. Weight of UH-1B Armored Seat, .50-Caliber System, and Center of Gravity.

The ballistic impact loads determined the design of the supports for the individual panels. The armored panels were designed to sustain the separate impact of projectiles. Simultaneous impact of two or more projectiles will defeat the armored panel. Therefore, maximum ballistic shock, defined as the "summation of energy expended upon the total surface area of any component by the total number of projectiles required to defeat it", is simply the ballistic shock imposed by the energy expended by one projectile at any given time.

The loads imposed during acceleration of the aircraft determined the design of the armored seat support structure.

2. Structural Design Criteria

a. Impact Stresses and Deflections

When a ballistic projectile impacts with an armored (tile-metal) panel, a large part of the initial kinetic energy is dissipated during fracture of the tile; and if the armor defeats the projectile, the remainder is absorbed during the propagation of elasto-plastic waves in the supporting structure. Approximate formulas for impact stresses have been developed,* and energy losses are determined by considering the momentum of the entire system before and after impact. Losses are conveniently taken into account by multiplying the available energy by a factor, K. This factor, however, neglects energy losses sustained during fracture of the tile.

In order to assess energy losses attributed to the tile-metal panel system, an armored test specimen, designed to defeat .30-caliber AP projectiles, was subjected to ballistic impact, and specific deflections were recorded. These data permitted correlation with theoretical values, and the factor K was modified accordingly. The modifying factor, K', is assumed to apply to any armored panel regardless of the form of structural restraint, since the tile fracture is quite localized.

The test specimen is shown in Figure 8.

*Raymond J. Roark, Formulas for Stress and Strain, Third Edition, McGraw-Hill Book Company, Inc., New York, New York, 1954, pp 331-332.

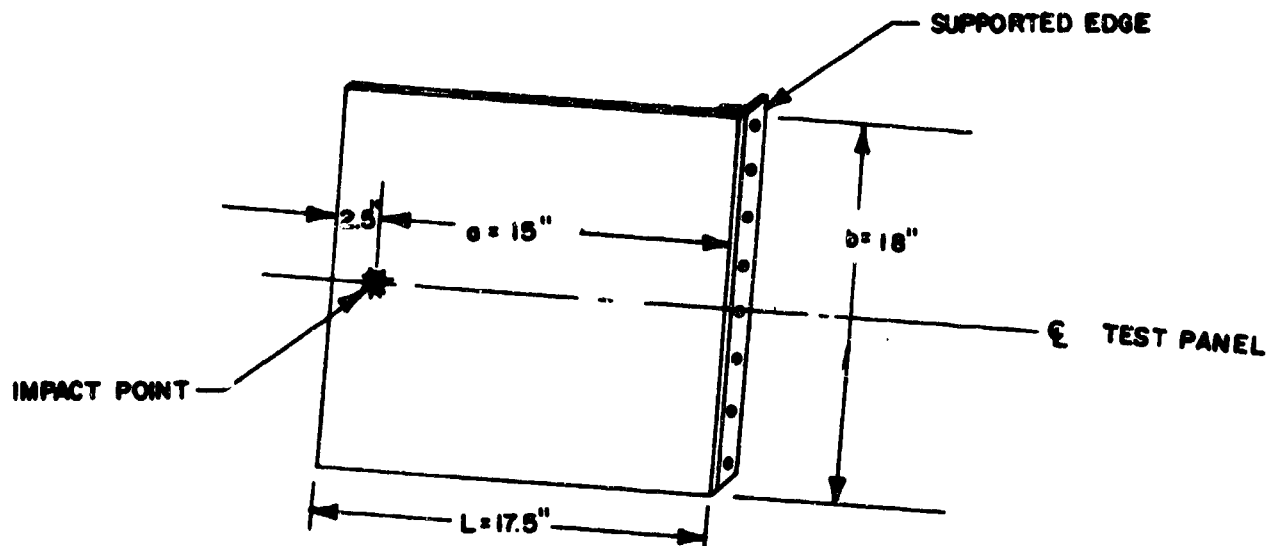

Figure 8. Armored Panel Test Specimen.

The armored panel was fixed at one end and subjected to ballistic impact at a point 2.50-inches from the opposite (free) end and on the horizontal center-line of the panel. Since the ratio of impact stress to static stress is equal to the ratio of impact deflection to static deflection, the following equation enables the determination of the modifying factor, K' :

$$\delta_1 / \delta_s = \sigma_1 / \sigma_s = \left(\frac{K' K V_1^2}{386.4 \delta_s} \right)^{1/2} \quad (1)$$

The theoretical maximum deflection at the free end is given by

$$\delta_1 = \left(\frac{\delta_s V_1^2 K' K}{386.4} \right)^{1/2} \quad (2)$$

where

- δ_s = static deflection (due to weight of the projectile)
- V_1 = the measured velocity at impact = 3.05×10^4 in./sec
- K' = tile-fracture energy loss factor

K = elasto-plastic energy loss factor (aluminum panel)

σ_1 and σ_s = impact and static stresses, respectively.

The deflection measured at the end of the test panel is

$$\delta_A = 0.50 \text{ in.}$$

Then

$$\delta_1 = \delta_A$$

and

$$K' = \frac{(\delta_A^2) (386.4)}{\delta_s V_1^2 K}.$$

For a cantilevered panel,*

$$\delta_s = \frac{W_p}{6 EI} (3a^2 L - a^3).$$

This equation yields the maximum deflection, at the end of the panel, for an intermediate load. Also

$$K = \frac{1 + \frac{33}{140} \frac{W_b}{W_p}}{\left(1 + \frac{3}{8} \frac{W_b}{W_p}\right)^2}$$

where

W_p = weight of projectile in lb ≈ 0.0235 (.30-caliber AP)

E = modulus of elasticity of aluminum plate = 10^7 psi

I = moment of inertia = $bt^3/12 = 18 (0.25)^3/12 = 0.0235$

W_b = weight of the tile-plate system = 23.5 lb

$\frac{W_b}{W_p} = 10^3.$

* Raymond J. Roark, Formulas for Stress and Strain, Third Edition, McGraw-Hill Book Company, Inc., New York, New York, 1954, p 100, case 2.

Substituting,

$$K = \frac{1 + \frac{33}{140} (10^3)}{\left[1 + \frac{3}{8} (10^3)\right]^2} = 1.68 \times 10^{-3}$$

$$\delta_s = \frac{0.0235 (8425)}{6(10^7) 0.0235} = 1.4 (10^{-4})$$

$$K' = \frac{(0.50)^2 386.4}{1.4 \times 10^{-4} (9.32 \times 10^8)(1.68 \times 10^{-3})}$$

$$K' = 0.44.$$

This factor is assumed to apply to the .50-caliber system as well.

b. Flight Acceleration Loads

Brackets and supporting hardware will be designed to sustain the following ultimate load factors:

$$A_{z_u} = \pm 7.0g$$

$$A_{y_u} = \pm 3.0g$$

$$A_{x_u} = \pm 3.0g$$

3. Structural Analysis

a. Ballistic Impact-Stress Analysis

Detailed analyses of all the armored panels of the seat were conducted. The results indicated that the impact stresses on the .50-caliber panels far exceeded the impact stresses on the other panels and had the lowest margin of safety. It is assumed that the shoulder panel, head protector, and side panel are cantilevered, as indicated in the following illustrations. It is assumed that the bottom panel and back panel are simply supported. The general impact stress equation is

$$\sigma_i = \sigma_s \left(\frac{0.44 K V_i^2}{386.4 \delta_s} \right)^{1/2} = \sigma_s V_i (0.0337) \left(\frac{K}{\delta_s} \right)^{1/2}$$

Nomenclature for the equation is presented in the test-panel analysis section. Ballistic impact stress analyses are presented below.

(1) Ballistic Impact Stress - Cantilevered Panels

Analysis-Shoulder Panel - The projectile is assumed to strike the shoulder panel as indicated in the figure. Impact at this point will result in the highest stresses in the aluminum angle which supports the armor plate at the shoulder-back connection point.

<u>.50-caliber system</u>	$E = 15 \times 10^6$ psi (titanium)
$h = 16$ in.	$W_p = 0.10$ lb
$t = 0.25$ in.	$W_b = 33.0$ lb
$L = 14$ in.	$\frac{W_b}{W_p} = 330$

$$K = \frac{1 + \frac{33 W_b}{140 W_p}}{\left(1 + \frac{3}{8} \frac{W_b}{W_p}\right)^2} = \frac{1 + 0.236 \frac{W_b}{W_p}}{\left(1 + 0.375 \frac{W_b}{W_p}\right)^2} = \frac{1 + 0.236 (330)}{[1 + 0.375 (330)]^2}$$

$$K = 50.6 (10^{-4})$$

$$M = W_p L = 0.10 (14) = 1.4 \text{ in.-lb}$$

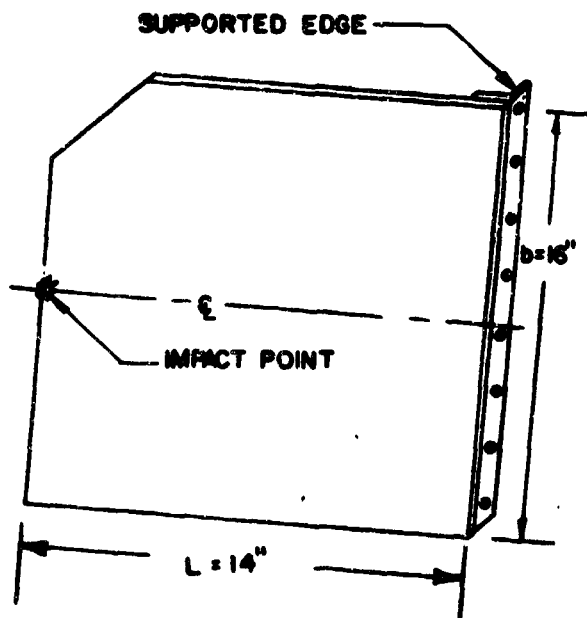

Figure 9. Shoulder Panel Geometry (.30 and .50 Caliber).

$$\sigma_s = \frac{6M}{bt^2} = \frac{6(1.4)}{16(0.25)^2} = 8.4 \text{ psi}$$

$$V_i = 2700 \text{ ft/sec} = 32,400 \text{ in./sec}$$

(standard round velocity at 100 yards)

$$I = \frac{bt^3}{12} = \frac{16(0.25)^3}{12} = 0.0208 \text{ in.}^4$$

$$\delta_s = \frac{W_p L^3}{3EI} = \frac{0.10(14)^3}{3(15)(10^6)0.0208}$$

$$= 2.93(10^{-4})$$

$$\sigma_i = \sigma_s V_i (0.0337) \left(\frac{K}{\delta_s} \right)^{1/2}$$

$$\sigma_i = 8.4(32,400)(0.0337) \left(\frac{50.6}{2.93} \right)^{1/2}$$

$$= 38,000 \text{ psi}$$

The ultimate tensile strength of the material of the supporting angle (2024-T4) is

$$F_{tu} = 62,000 \text{ psi.}$$

The margin of safety is

$$\text{M.S.} = \frac{F_{tu}}{\sigma_i} - 1 = +0.63.$$

.30-caliber system

$$b = 16 \text{ in.}$$

$$t = 0.25 \text{ in.}$$

$$L = 14 \text{ in.}$$

$$E = 10^7 \text{ psi (aluminum)}$$

$$W_p = 0.0235 \text{ lb}$$

$$W_b = 20 \text{ lb}$$

$$\frac{W_b}{W_p} = 852$$

$$\frac{W_b}{W_p}$$

$$K = \frac{1 + 0.236 (852)}{[1 + 0.375 (852)]^2} = 19.7 (10^{-4})$$

$$M = W_p L = 0.0235 (14) = 0.329 \text{ in.-lb}$$

$$\sigma_s = \frac{6M}{bt^2} = \frac{6 (0.329)}{16 (0.25)^2} = 1.975 \text{ psi}$$

$$V_1 = 30,500 \text{ in./sec (standard-round velocity at 100 yards)}$$

$$I = \frac{bt^3}{12} = \frac{16 (0.25)^3}{12} = 0.0208 \text{ in.}^4$$

$$\delta_s = \frac{W_p L^3}{3 EI} = \frac{0.0235 (14)^3}{3 (10^7) 0.0208} = 1.033 (10^{-4})$$

$$\sigma_1 = \sigma_s V_1 (0.0337) \left(\frac{K}{\delta_s} \right)^{1/2}$$

$$\sigma_1 = 1.975 (30,500)(0.0337) \left(\frac{19.7}{1.033} \right)^{1/2}$$

$$\sigma_1 = 8,840 \text{ psi}$$

The margin of safety is

$$\text{M.S.} = \frac{F_{tu}}{\sigma_1} = \frac{62,000}{8,840} - 1 = +6.0.$$

Head-Protector Panel

.50-caliber system

b = 11.75 in.	$W_p = 0.10 \text{ lb}$
t = 0.25 in.	$W_b = 13.82 \text{ lb}$
L = 9.75 in.	$\frac{W_b}{W_p} = 138.2$
E = $15 (10^6) \text{ psi}$	

$$K = \frac{1 + 0.236 (138.2)}{[1 + 0.375 (138.2)]^2} = 120(10^{-4})$$

$$M = W_p L = 0.10 (9.75) = 0.975$$

$$\sigma_s = \frac{6 M}{bt^2} = \frac{6 (0.975)}{11.75 (0.25)^2} = 7.98 \text{ psi}$$

$$V_1 = 32,400 \text{ in./sec}$$

$$I = \frac{bt^3}{12} = \frac{11.75 (0.25)^3}{12} = 0.0153 \text{ in.}^4$$

$$\delta_s = \frac{W_p L^3}{3 EI} = \frac{0.10 (9.75)^3}{3 (15)(10^6) 0.0153}$$

$$= 1.35 (10^{-4})$$

$$\sigma_1 = \sigma_s v_1 (0.0337) \left(\frac{K}{\delta_s} \right)^{1/2}$$

$$\sigma_1 = 7.98 (32,400) (0.0337) \left(\frac{120}{1.35} \right)^{1/2}$$

$$= 82,000 \text{ psi}$$

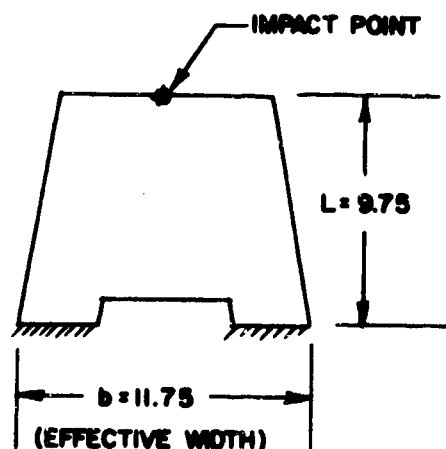

Figure 10. Head Protector Panel Geometry (.30 and .50 Caliber).

The allowable ultimate stress of the supporting bracket (titanium - 6Al-4V) is

$$F_{tu} = 130,000 \text{ psi.}$$

The margin of safety is

$$\text{M.S.} = \frac{F_{tu}}{\sigma_1} - 1 = \frac{130,000}{82,000} - 1 = +0.59.$$

.30-caliber system

$$\begin{aligned} b &= 11.75 \text{ in.} & W_p &= 0.0235 \text{ lb} \\ t &= 0.25 \text{ in.} & W_b &= 8.5 \text{ lb} \\ L &= 9.75 \text{ in.} & \frac{W_b}{W_p} &= 361 \\ E &= 10^7 \text{ psi} \end{aligned}$$

$$K = \frac{1 + 0.236 (361)}{[1 + 0.375 (361)]^2} = 45.8 (10^{-4})$$

$$M = W_p L = 0.0235 (9.75) = 0.229 \text{ in./lb}$$

$$\sigma_s = \frac{6M}{bt^2} = \frac{6 (0.229)}{11.75 (0.25)^2} = 1.875 \text{ psi}$$

$$V_1 = 30,500 \text{ in./sec}$$

$$I = \frac{bt^3}{12} = \frac{11.75 (0.25)^3}{12} = 0.0153 \text{ in.}^4$$

$$\delta_s = \frac{W_p L^3}{3EI} = \frac{0.0235 (9.75)^3}{3(10^7)(0.0153)} = 0.474 (10^{-4})$$

$$\sigma_1 = \sigma_s V_1 (0.0337) \left(\frac{K}{\delta_s} \right)^{1/2}$$

$$\sigma_1 = 1.875 (30,500)(0.0337) \left(\frac{45.8}{0.474} \right)^{1/2} = 19,000 \text{ psi}$$

The allowable ultimate stress of the material of the supporting bracket (2024-T4) is

$$F_{tu} = 62,000 \text{ psi.}$$

The margin of safety is

$$M.S. = \frac{F_{tu}}{\sigma_1} - 1 = \frac{62,000}{19,000} - 1 = +2.26.$$

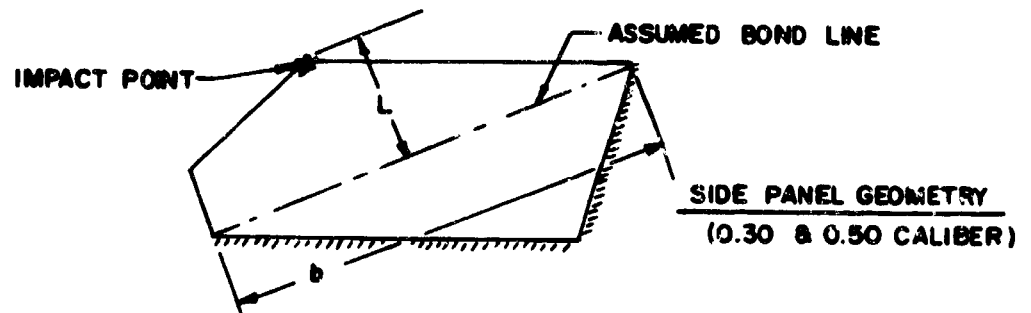

Figure 11. Side Panel Geometry
(.30 and .50 Caliber).

Seat-Side Panel

.50-caliber system

$b = 20 \text{ in.}$

$t = 0.25 \text{ in.}$

$L = 6.0 \text{ in.}$

$E = 15 (10^6) \text{ psi.}$

$W_p = 0.10 \text{ lb}$

$W_b = \text{weight of cantilevered segment} \approx 0.40 (W_{bt})$

$W_b = 0.40 (25.28) \approx 10.1$

$\frac{W_b}{W_p} = 100$

$$K = \frac{1 + 0.236 (100)}{[1 + 0.375 (100)]^2} = 166 (10^{-4})$$

$M = W_p L = 0.10 (6) = 0.60 \text{ in./lb}$

$$\sigma_s = \frac{6M}{bt^2} = \frac{6 (0.60)}{20 (0.25)^2} = 2.88 \text{ psi}$$

$$V_1 = 32,400 \text{ in./sec}$$

$$I = \frac{bt^3}{12} = \frac{20 (0.25)^3}{12} = 0.026 \text{ in.}^4$$

$$\delta_s = \frac{W_p L^3}{3EI} = \frac{0.10 (6)^3}{(3)(15)(10^6)(0.026)} = 0.1845 (10^{-4})$$

$$\sigma_i = \sigma_s V_1 (0.0337) \left(\frac{K}{\delta_s} \right)^{1/2}$$

$$\sigma_i = 2.88 (32,400)(0.0337) \left(\frac{166}{0.1845} \right)^{1/2} = 93,300 \text{ psi}$$

The margin of safety is

$$\text{M.S.} = \frac{F_{tu}}{\sigma_i} - 1 = \frac{130,000}{93,300} - 1 = +0.39.$$

.30-caliber system

$$b = 20 \text{ in.}$$

$$W_p = 0.0235 \text{ lb}$$

$$t = 0.25 \text{ in.}$$

$$W_b = 0.40 (W_{b_{\text{total}}}) = 0.40(15.23)$$

$$L = 6.0 \text{ in.}$$

$$= 6.1 \text{ lb}$$

$$E = 10^7 \text{ psi}$$

$$\frac{W_b}{W_p} = 260$$

$$K = \frac{1 + 0.236 (260)}{[1 + 0.375 (260)]^2} = 64.3 (10^{-4})$$

$$M = W_p L = 0.0235 (6.0) = 0.141 \text{ in./lb}$$

$$\sigma_s = \frac{6M}{bt^2} = \frac{6 (0.141)}{20 (0.25)^2} = 0.677 \text{ psi}$$

$$V_1 = 30,500 \text{ in./sec}$$

$$I = \frac{bt^3}{12} = \frac{20 (0.25)^3}{12} = 0.026 \text{ in.}^4$$

RY
BER)

ntilevered
40 (W_{b_{total}})

≈ 10 lb

$$\delta_s = \frac{W_p L^3}{3EI} = \frac{0.0235 (6)^3}{3 (10^7)(0.026)} = 0.065 (10^{-4})$$

$$\begin{aligned} \sigma_1 &= \sigma_s v_1 (0.0337) \left(\frac{K}{\delta_s} \right)^{1/2} \\ &= 0.677 (30,500)(0.0337) \left(\frac{64.3}{0.065} \right)^{1/2} = 21,800 \text{ psi} \end{aligned}$$

The margin of safety is

$$\text{M.S.} = \frac{F_{tu}}{\sigma_1} = \frac{62,000}{21,800} - 1 = +1.84.$$

(2) Ballistic Impact Stress - "Simply Supported" Panels

Analysis - Bottom Panel - The armored panel is assumed to be "simply supported," with the projectile impacting at the center of the panel as shown in the figure.

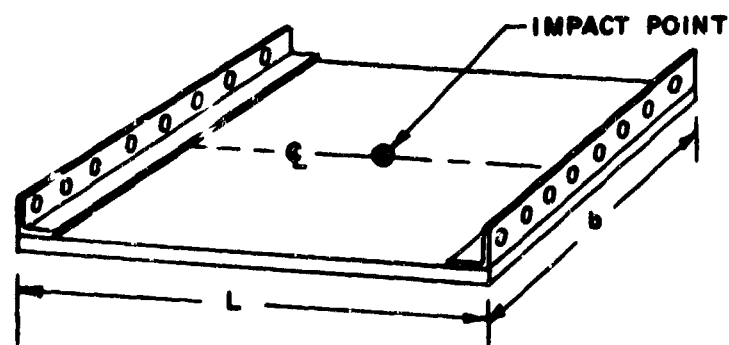

Figure 12. Bottom Panel Geometry (.30 and .50 Caliber).

.50 caliber system

b = 15 in.

$W_p = 0.10\text{-lb}$

t = 0.25 in.

$W_b = 40.23 \text{ lb}$

L = 15 in.

$\frac{W_b}{W_p} = 402.3$

E = $15 (10^6)$ psi

W_p

$$K = \frac{1 + \frac{17}{35} \frac{W_b}{W_p}}{\left(1 + \frac{5}{8} \frac{W_b}{W_p}\right)^2} = \frac{1 + 0.486 (402.3)}{\left[1 + 0.625 (402.3)\right]^2} = 30.9 (10^{-4})$$

$$M = \frac{W_p L}{4} = \frac{0.10 (15)}{4} = 0.375 \text{ in./lb}$$

$$\sigma_s = \frac{6M}{bt^2} = \frac{6 (0.375)}{15 (0.25)^2} = 2.4 \text{ psi}$$

$$V_1 = 32,400 \text{ in./sec}$$

$$I = \frac{bt^3}{12} = \frac{15 (0.25)^3}{12} = 0.0195 \text{ in.}^4$$

$$\delta_s = \frac{W_p L^3}{48EI} = \frac{0.10 (15)^3}{48 (15)(10^6)(0.0195)} = 0.24 (10^{-4})$$

$$\sigma_1 = \sigma_s V_1 (0.0337) \left(\frac{K}{\delta_s}\right)^{1/2}$$

$$\sigma_1 = 2.4 (32,400)(0.0337) \left(\frac{30.9}{0.24}\right)^{1/2} = 29,700 \text{ psi}$$

The allowable stress of the material of the supporting angle (6061-T6) is

$$F_{tu} = 38,000 \text{ psi.}$$

The margin of safety is

$$\text{M.S.} = \frac{38,000}{29,700} - 1 = +0.28.$$

.30-caliber system

$$\begin{array}{ll} b = 15 \text{ in.} & W_p = 0.0235 \text{ lb} \\ t = 0.25 \text{ in.} & W_b = 24.40 \text{ lb} \\ L = 15 \text{ in.} & \frac{W_b}{W_p} = 1,038 \\ E = 10^7 \text{ psi} & \end{array}$$

$$K = \frac{1 + 0.486 (1,038)}{[1 + 0.625 (1,038)]^2} = 12 (10^{-4})$$

$$M = \frac{W_p L}{4} = \frac{0.0235 (15)}{4} = 0.0882 \text{ in./lb}$$

$$\sigma_s = \frac{6M}{bt^2} = \frac{6 (0.0882)}{15 (0.25)^2} = 0.565 \text{ psi}$$

$$V_1 = 30,500 \text{ in./sec}$$

$$I = \frac{bt^3}{12} = \frac{15 (0.25)^3}{12} = 0.0195 \text{ in.}^4$$

$$\delta_s = \frac{W_p L^3}{48EI} = \frac{0.0235 (15)^3}{48 (10^7)(0.0195)} = 0.0846 (10^{-4}) \text{ in.}$$

$$\sigma_1 = \sigma_s V_1 (0.0337) \left(\frac{K}{\delta_s} \right)^{1/2}$$

$$\sigma_1 = 0.565 (30,500)(0.0337) \left(\frac{12}{0.0846} \right)^{1/2} = 6,910 \text{ psi}$$

The margin of safety is

$$\text{M.S.} = \frac{38,000}{6,910} - 1 = +4.5.$$

Analysis - Back Panel - The critical area in the back occurs in the lower half. The upper half supports the shoulder panel and head protection masses, which attenuate the impact stresses considerably (see Figure 4). The lower segment of the back panel will be assumed to be "simply supported," as shown in the figure.

.50-caliber system

$$\begin{aligned}
 b &= 13.0 \text{ in.} \\
 t &= 0.25 \text{ in.} \\
 L &= 16.0 \text{ in.} \\
 E &= 15 (10^6) \text{ psi} \\
 W_p &= 0.10 \text{ lb} \\
 W_b &= 30 \text{ lb (lower segment)} \\
 \frac{W_b}{W_p} &= 300
 \end{aligned}$$

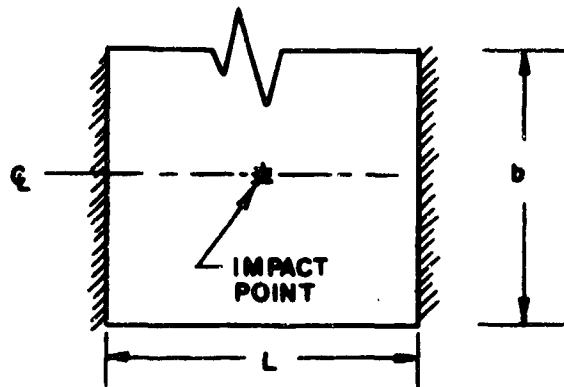

Figure 13. Lower Segment, Back Panel.

$$K = \frac{1 + 0.486 (300)}{[1 + 0.625 (300)]^2} = 41.3 (10^{-4})$$

$$M = \frac{W_p L}{4} = \frac{0.10 (16)}{4} = 0.40 \text{ in./lb}$$

$$\sigma_s = \frac{6M}{bt^2} = \frac{6 (0.40)}{13 (0.25)^2} = 2.95 \text{ psi}$$

$$V_1 = 32,400 \text{ in./sec}$$

$$I = \frac{bt^3}{12} = \frac{13 (0.25)^3}{12} = 0.0169 \text{ in.}^4$$

$$\delta_s = \frac{W_p L^3}{48EI} = \frac{0.10 (16)^3}{48 (15)(10^6)(0.0169)} = 0.337 (10^{-4})$$

$$\sigma_1 = \sigma_s V_1 (0.0337) \left(\frac{K}{\delta_s} \right)^{1/2}$$

$$\sigma_1 = 2.95 (32,400)(0.0337) \left(\frac{41.3}{0.337} \right)^{1/2} = 35,800 \text{ psi}$$

The margin of safety is

$$\text{M.S.} = \frac{130,000}{35,800} - 1 = 2.64.$$

.30-caliber system

$$\begin{aligned} b &= 13.0 \text{ in.} & W_p &= 0.0235 \text{ lb} \\ t &= 0.25 \text{ in.} & W_b &= 19.2 \text{ lb (lower segment)} \\ L &= 16.0 \text{ in.} & \frac{W_b}{W_p} &= \frac{19.2}{0.0235} = 817 \\ E &= 10^7 \text{ psi} \end{aligned}$$

$$K = \frac{1 + 0.486 (817)}{[1 + 0.625 (817)]^2} = 15.25 (10^{-4})$$

$$M = \frac{W_p L}{4} = \frac{0.0235 (16)}{4} = 0.0940 \text{ in./lb}$$

$$\sigma_s = \frac{6M}{bt^2} = \frac{6 (0.094)}{13 (0.25)^2} = 0.694 \text{ psi}$$

$$V_1 = 30,500 \text{ in./sec}$$

$$I = \frac{bt^3}{12} = \frac{13 (0.25)^3}{12} = 0.0169 \text{ in.}^4$$

$$\delta_s = \frac{W_p L^3}{48EI} = \frac{0.0235 (16)^3}{48 (10^7) 0.0169} = 0.119 (10^{-4})$$

$$\sigma_1 = 0.694 (30,500)(0.0337) \left(\frac{15.25}{0.119} \right)^{1/2} = 8,000 \text{ psi}$$

The margin of safety is

$$\text{M.S.} = \frac{F_{tu}}{\sigma_1} = \frac{62,000}{8,000} - 1 = +6.75.$$

b. Flight Acceleration Load Analysis

The flight acceleration loads govern the design of the armored shell support brackets and A-frame structure. A free body of the armored shell is shown in Figure 14.

The resultant cg of the pilot and seat is also shown in Figure 14. The applied flight loads are as follows:

$$P_z = \pm(W_s + W_p) 7.0g$$

$$P_x = \pm(W_s + W_p) 3.0g$$

$$P_y = \pm(W_s + W_p) 3.0g$$

where

W_s = weight of shell and applicable support structure
 ≈ 320 lb (.50 caliber)

W_p = weight of pilot = 180 lb

These are ultimate loads and will be applied individually.

$$P_z = \pm(180 + 320) 7.0 = \pm 3,500 \text{ lb}$$

$$P_x = P_y = \pm(500) 3.0 = \pm 1,500 \text{ lb}$$

Vertical Load Analysis (P_z)

The vertical and horizontal forces (V and H) are determined as follows:

$$V = \frac{P_z}{4} = \frac{3,500}{4} = 875 \text{ lb}$$

$$H = \frac{P_z (9)}{11.7 (2)} = 1,345 \text{ lb}$$

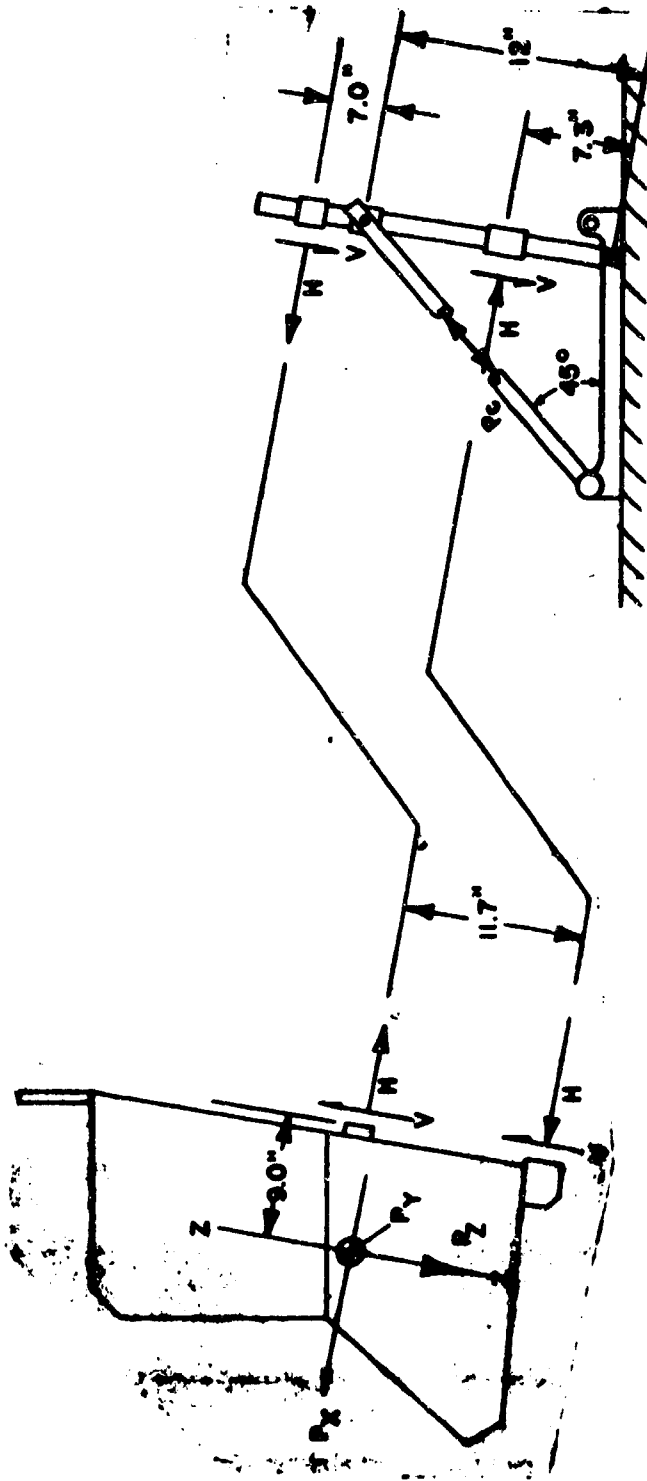

Figure 14. Free Body of Armored Shell and A-Frame (Vertical Load Condition).

The diagonal tubular member load is

$$P_c = \frac{H (11.7)}{12 (\cos 45^\circ)} = 1,855 \text{ lb.}$$

The free body of the vertical strut is shown in Figure 15.

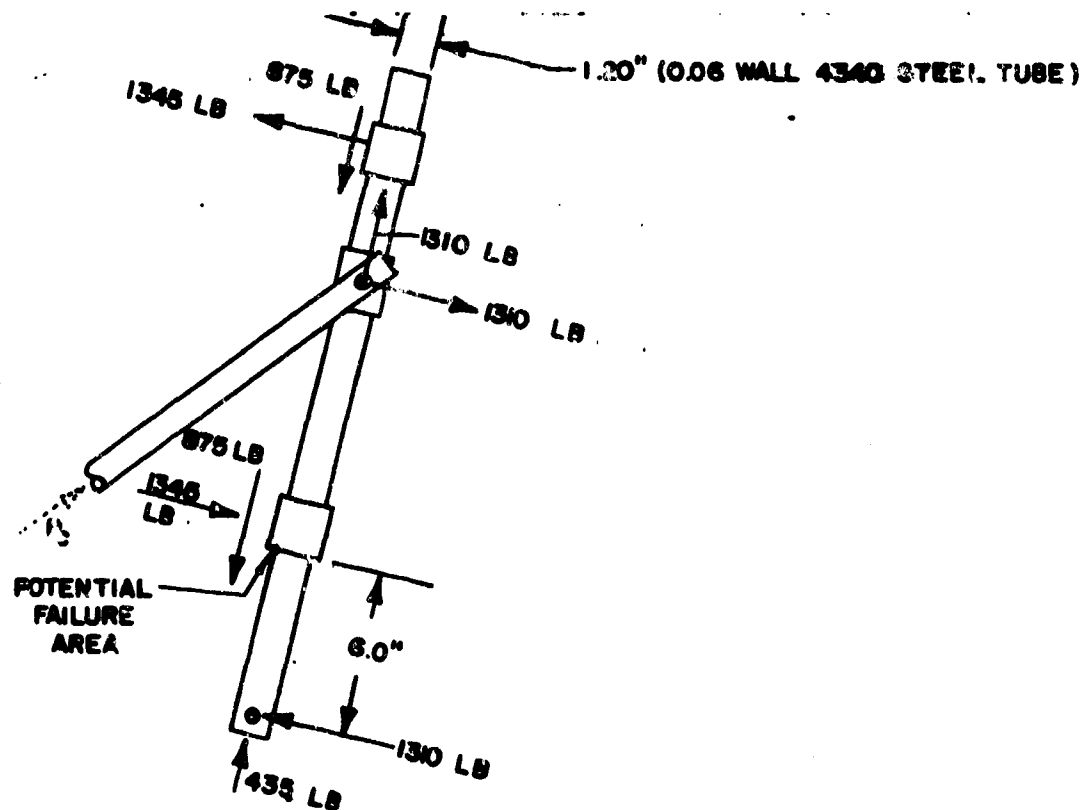

Figure 15. Free Body of Vertical Strut.

The bending moment developed in this member in the "potential failure" area indicated in Figure 15 is

$$M_{cr} = 1310 (6) = 7,860 \text{ in. -lb.}$$

The bending stress,

$$\sigma_b = \frac{M_{cr} R_o}{I} ; R_o = 0.60; R_1 = (R_o - 0.06) = 0.54 \text{ in.}$$

$$= \frac{7,860 (0.60)}{\frac{\pi}{4} (R_o^4 - R_1^4)} = 134,500 \text{ psi}$$

The ultimate allowable stress for 4340 heat-treated steel is

$$F_{tu} = 150,000 \text{ psi.}$$

The margin of safety is

$$\text{M.S.} = \frac{150,000}{134,500} - 1 = 0.115.$$

This potential failure was verified by tests conducted by the Hardman Tool and Engineering Company. * The structure sustained an ultimate failure in the vertical strut at a vertical load of 4,000 pounds. The failure is shown in Figure 16.

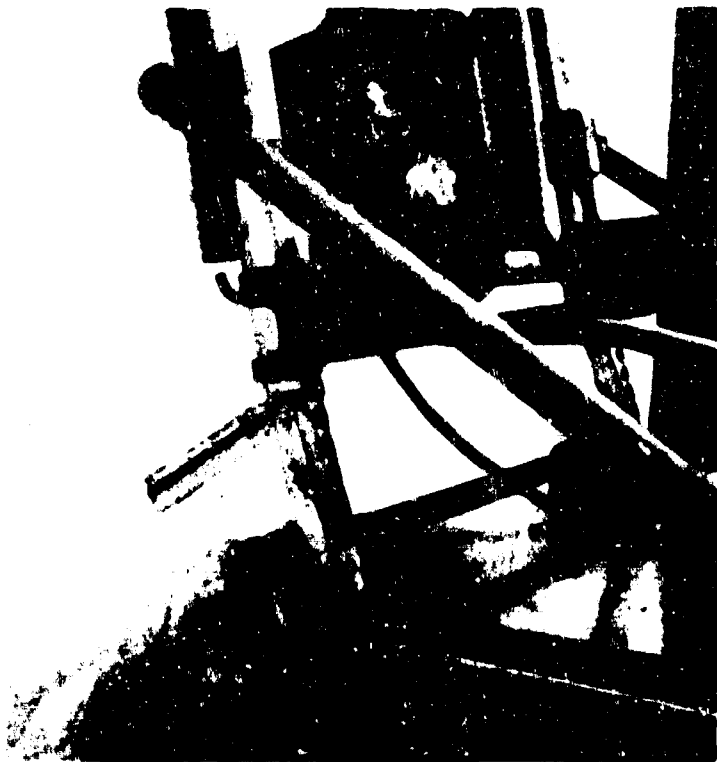

Figure 16. Result of Downward Load Application. (Note Failure of Vertical Strut Members; Ultimate Load, 4,000 pounds.)

*UH-1 Armored Helicopter Seat Test, Hardman Tool & Engineering Company, Test Report 249, 14 May 1965.

Seat-Back, Forward-Load Analysis

The diagonal-tube member is subjected to compression and bending and will govern the response of the structure. Bending is induced due to eccentric loading. The free body of the primary structure is shown in Figure 17.

The restraint afforded by the forward tube of the carriage is conservatively neglected. The axial load in the member is given by

$$\begin{aligned} P_c &= \frac{P_x (19)}{12 (\cos 45^\circ)} \cdot \frac{1}{2} \\ &= \frac{1500 (19)}{24 (\cos 45^\circ)} = 1,680 \text{ lb.} \end{aligned}$$

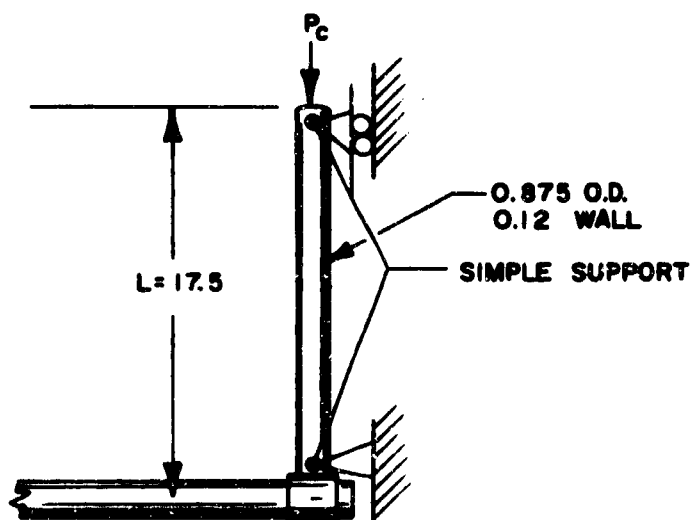

Figure 17. Free Body of Diagonal-Tube Member (Forward Load Condition).

The point of maximum bending moment (χ) is

$$\tan \frac{\chi}{j} = \frac{\cos \frac{L}{j}}{\sin \frac{L}{j}} = \frac{0.61375}{0.78950} = 0.777$$

where

$$L = 17.5 \text{ in.}$$

$$j = \sqrt{\frac{EI}{P_c}} = 19.3 \text{ in.}$$

$$E = 30 \times 10^6 \text{ psi}$$

$$I = 0.0208 \text{ in.}^4$$

$$\frac{\lambda}{j} = \tan^{-1} 0.777 = 0.66 \text{ radian}$$

$$\lambda = 0.66 (19.3) = 12.72 \text{ in.}$$

The maximum bending moment is

$$M_{\max} = \frac{M}{\cos \frac{\lambda}{j}}$$

where

$$M = (P_c) z = 3360 \text{ in.-lb}$$

$$\cos \frac{\lambda}{j} = 0.79$$

$$M_{\max} = \frac{3360}{0.79} = 4250 \text{ in.-lb}$$

The bending stress is

$$f_b = \frac{MR}{I} = \frac{4250 (0.4375)}{\frac{\pi}{4} (R_o^4 - R_i^4)}; \quad R_o = 0.4375$$
$$R_i = 0.3175$$

$$f_b = 89,500 \text{ psi.}$$

The axial stress is

$$f_a = \frac{P_c}{A} = \frac{1680}{0.29} = 5800 \text{ psi.}$$

The combined stress is

$$f_c = f_b + f_a = 89,500 + 5800 = 95,300 \text{ psi.}$$

The allowable stress for 4130 heat treated steel is

$$F_{tu} = 125,000 \text{ psi.}$$

The margin of safety is

$$\text{M.S.} = \frac{125,000}{95,300} - 1 = +0.31.$$

A forward-load test was conducted by the Hardman Engineering Company and substantiated the fact that the diagonal member governs the response of the structure for this load condition. Figure 18 shows the failure of the diagonal members at a forward load of 2,600 pounds.

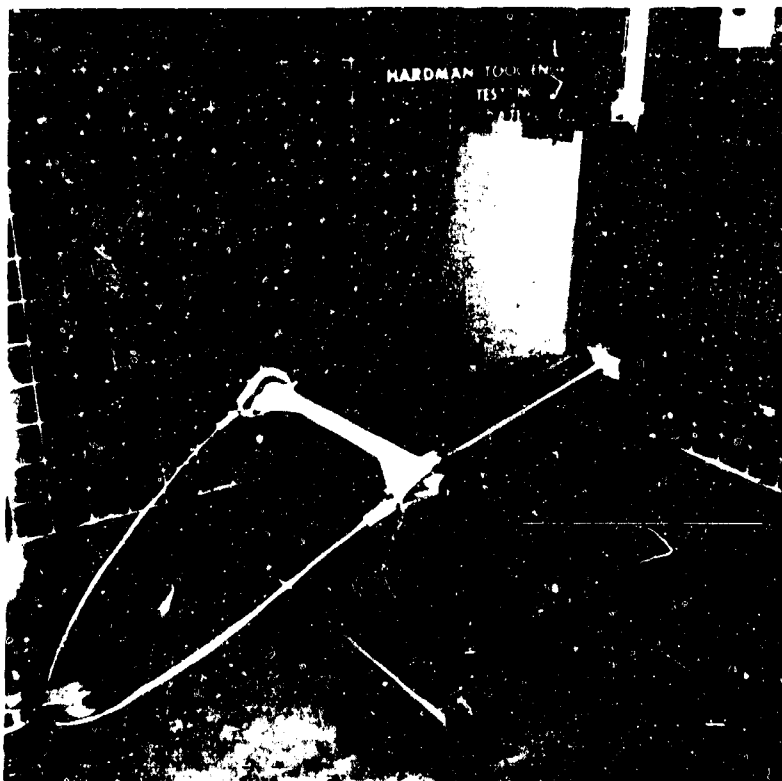

Figure 18. Result of Forward Load Application. (Note Bend of Diagonals Indicating Failure; Ultimate Forward Load, 2,600 pounds.)

Seat - Side Load Analysis

The applied load is imposed on the aft vertical frame of the carriage. The critical area occurs at the lower connection point for the vertical tubular member, as shown in Figure 19. The tension load applied to the rail induces shear directly above the lower bolted connected point on the rail. The applied shear load,

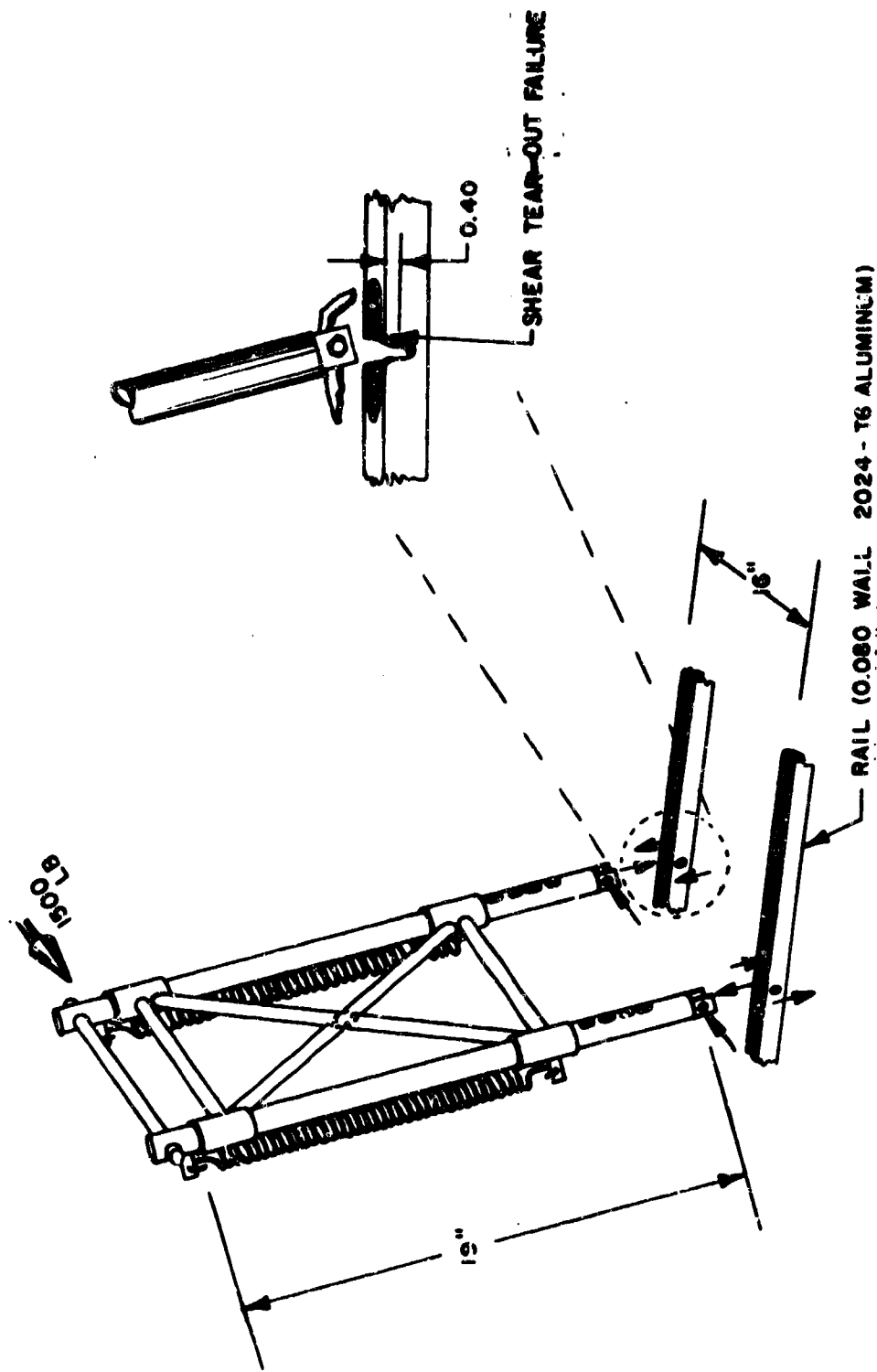

Figure 19. Free Body, Carriage Vertical Frame (Side Load Condition).

$$P_s = \frac{1,500 (19)}{16} = 1,785 \text{ lb.}$$

The shear tear-out area (rail) is

$$A_s = 0.40 (0.080) 4 = 0.128 \text{ in.}^2$$

The shear stress is

$$\sigma_s = \frac{P_s}{A_s} = \frac{1,785}{0.128} = 14,000 \text{ psi.}$$

The allowable ultimate shear stress for the rail (2024-T42) is

$$F_{su} = 35,000 \text{ psi.}$$

The margin of safety is

$$\text{M.S.} = \frac{35,000}{14,000} - 1 = +1.5.$$

A side load test was conducted by the Hardman Engineering Company. The structure failed, in the manner outlined above, at a load of 4,800 pounds. This is shown in Figure 20.

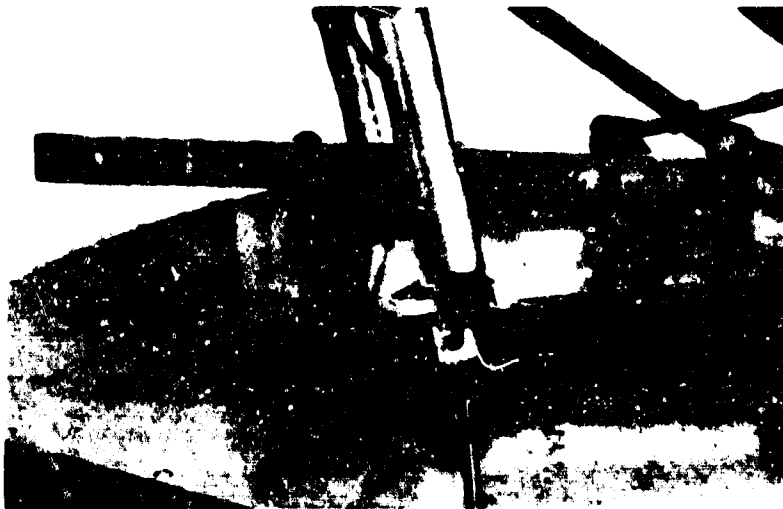

Figure 20. Result of Sideward-Load Application (Note Tear-Out at Track Rail; Failure Load, 4,800 Pounds).

DISTRIBUTION

US Army Materiel Command	7
US Army Mobility Command	5
US Army Aviation Materiel Command	7
US Army Aviation Materiel Laboratories	18
US Army R&D Group (Europe)	2
US Army Engineer R&D Laboratories	2
US Army Human Engineering Laboratories	1
US Army Test and Evaluation Command	1
US Army Combat Developments Command, Fort Belvoir	2
US Army Combat Developments Command Transportation Agency	1
US Army War College	1
US Army Command and General Staff College	1
US Army Aviation School	1
US Army Infantry Center	2
US Army Field Office, AFSC, Andrews AFB	1
Systems Engineering Group (RTD), Wright-Patterson AFB	1
Bureau of Naval Weapons, DN	2
US Naval Research Laboratory	1
Marine Corps Liaison Officer, US Army Transportation School	1
Research Analysis Corporation	1
US Army Board for Aviation Accident Research	1
US Naval Aviation Safety Center	1
Defense Documentation Center	20

~~UNCLASSIFIED~~

Security Classification:

DOCUMENT CONTROL DATA - R&D		
<i>(Security classification of title, body of abstract and indexing annotation must be entered when the overall report is classified)</i>		
1. ORIGINATING ACTIVITY (Corporate author) Aerojet-General Corporation Azusa, California		2a. REPORT SECURITY CLASSIFICATION Unclassified
		2b. GROUP
3. REPORT TITLE DESIGN STUDY AND FABRICATION OF TWO INTERCHANGEABLE UH-1 AIRCREW ARMOR SYSTEMS		
4. DESCRIPTIVE NOTES (Type of report and inclusive dates) Final Report, 21 July 1964 - 2 August 1965		
5. AUTHOR(S) (Last name, first name, initial) Fernandez, D. Sheldon, H.W.		
6. REPORT DATE April 1966	7a. TOTAL NO. OF PAGES 52	7b. NO. OF REFS 2
8a. CONTRACT OR GRANT NO. DA 44-177-AMC-224(T) A. PROJECT NO.	9a. ORIGINATOR'S REPORT NUMBER(S) USAAVLABS Technical Report 66-23	
c. Task No. 1A121401A15003 d.	9b. OTHER REPORT NO(S) (Any other numbers that may be assigned this report) Aerojet Report No. 2950	
10. AVAILABILITY/LIMITATION NOTICES Distribution of this document is unlimited.		
11. SUPPLEMENTARY NOTES	12. SPONSORING MILITARY ACTIVITY U.S. Army Aviation Materiel Laboratories Fort Eustis, Virginia	
13. ABSTRACT The design and evaluation of two interchangeable UH-1 aircrew armor systems capable of defeating 7.62mm, .30-caliber, and .50-caliber AP ammunition are described. The design features of the systems are described, and a structural analysis of the system is presented.		

DD FORM 1473
1 JAN 64

~~UNCLASSIFIED~~

Security Classification

UNCLASSIFIED
Security Classification

14. KEY WORDS	LINK A		LINK B		LINK C	
	ROLE	WT	ROLE	WT	ROLE	WT
Helicopter, UH-1 Armor Interchangeable Aircrew .30-caliber AP defeating .50-caliber AP defeating 7.62-mm AP defeating Seat Kit, Armor						

INSTRUCTIONS

1. **ORIGINATING ACTIVITY:** Enter the name and address of the contractor, subcontractor, grantee, Department of Defense activity or other organization (*corporate author*) issuing the report.

2a. **REPORT SECURITY CLASSIFICATION:** Enter the overall security classification of the report. Indicate whether "Restricted Data" is included. Marking is to be in accordance with appropriate security regulations.

2b. **GROUP:** Automatic downgrading is specified in DoD Directive 5200.10 and Armed Forces Industrial Manual. Enter the group number. Also, when applicable, show that optional markings have been used for Group 3 and Group 4 as authorized.

3. **REPORT TITLE:** Enter the complete report title in all capital letters. Titles in all cases should be unclassified. If a meaningful title cannot be selected without classification, show title classification in all capitals in parenthesis immediately following the title.

4. **DESCRIPTIVE NOTES:** If appropriate, enter the type of report, e.g., interim, progress, summary, annual, or final. Give the inclusive dates when a specific reporting period is covered.

5. **AUTHOR(S):** Enter the name(s) of author(s) as shown on or in the report. Enter last name, first name, middle initial. If military, show rank and branch of service. The name of the principal author is an absolute minimum requirement.

6. **REPORT DATE:** Enter the date of the report as day, month, year, or month, year. If more than one date appears on the report, use date of publication.

7a. **TOTAL NUMBER OF PAGES:** The total page count should follow normal pagination procedures, i.e., enter the number of pages containing information.

7b. **NUMBER OF REFERENCES:** Enter the total number of references cited in the report.

8a. **CONTRACT OR GRANT NUMBER:** If appropriate, enter the applicable number of the contract or grant under which the report was written.

8b, 8c, & 8d. **PROJECT NUMBER:** Enter the appropriate military department identification, such as project number, subproject number, system numbers, task number, etc.

9a. **ORIGINATOR'S REPORT NUMBER(S):** Enter the official report number by which the document will be identified and controlled by the originating activity. This number must be unique to this report.

9b. **OTHER REPORT NUMBER(S):** If the report has been assigned any other report numbers (*either by the originator or by the sponsor*), also enter this number(s).

10. **AVAILABILITY/LIMITATION NOTICES:** Enter any limitations on further dissemination of the report, other than those

imposed by security classification, using standard statements such as:

- (1) "Qualified requesters may obtain copies of this report from DDC."
- (2) "Foreign announcement and dissemination of this report by DDC is not authorized."
- (3) "U. S. Government agencies may obtain copies of this report directly from DDC. Other qualified DDC users shall request through _____."
- (4) "U. S. military agencies may obtain copies of this report directly from DDC. Other qualified users shall request through _____."
- (5) "All distribution of this report is controlled. Qualified DDC users shall request through _____."

If the report has been furnished to the Office of Technical Services, Department of Commerce, for sale to the public, indicate this fact and enter the price, if known.

11. **SUPPLEMENTARY NOTES:** Use for additional explanatory notes.

12. **SPONSORING MILITARY ACTIVITY:** Enter the name of the departmental project office or laboratory sponsoring (*paying for*) the research and development. Include address.

13. **ABSTRACT:** Enter an abstract giving a brief and factual summary of the document indicative of the report, even though it may also appear elsewhere in the body of the technical report. If additional space is required, a continuation sheet shall be attached.

It is highly desirable that the abstract of classified reports be unclassified. Each paragraph of the abstract shall end with an indication of the military security classification of the information in the paragraph, represented as (TS), (S), (C), or (U).

There is no limitation on the length of the abstract. However, the suggested length is from 150 to 225 words.

14. **KEY WORDS:** Key words are technically meaningful terms or short phrases that characterize a report and may be used as index entries for cataloging the report. Key words must be selected so that no security classification is required. Identifiers, such as equipment model designation, trade name, military project code name, geographic location, may be used as key words but will be followed by an indication of technical context. The assignment of links, rules, and weights is optional.

UNCLASSIFIED

Security Classification

2592-66