

AD

USATEA Report 66-11

Engineering Report

PERSHING TRANSPORTABILITY STUDY

Calculations and Analysis of Railway Tests,
Vol I of IV

July 1966

AD 695 240

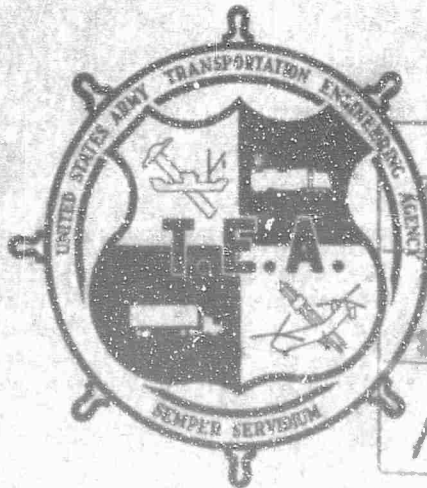

CLEARINGHOUSE
FOR FEDERAL SCIENTIFIC AND
TECHNICAL INFORMATION

Hardcopy	Microfilm
2.00	.50
29 ⁰⁰ AD	
1 ARCHIVE COPY	

U. S. ARMY
TRANSPORTATION ENGINEERING AGENCY
FORT EUSTIS, VIRGINIA

DISCLAIMER NOTICE

The findings in this report are not to be construed as an official Department of the Army position unless so designated by other authorized documents.

DDC AVAILABILITY NOTICE

Distribution of this document is unlimited.

DISPOSITION INSTRUCTIONS

Destroy this report when no longer needed. Do not return it to the originator.

DISCLAIMER NOTICE

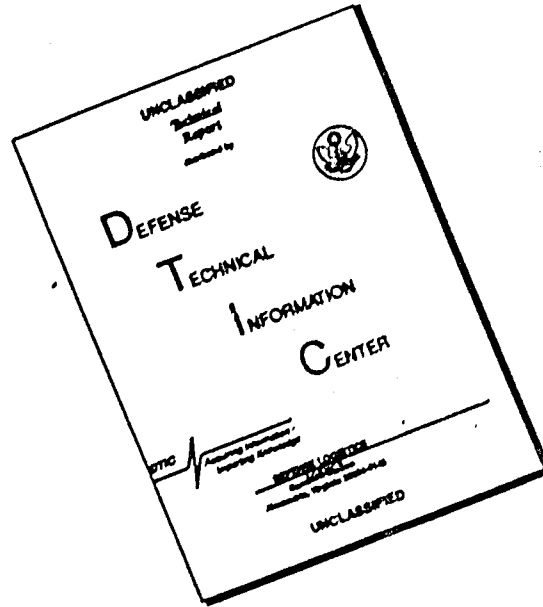

THIS DOCUMENT IS BEST QUALITY AVAILABLE. THE COPY FURNISHED TO DTIC CONTAINED A SIGNIFICANT NUMBER OF PAGES WHICH DO NOT REPRODUCE LEGIBLY.

ENGINEERING REPORT

PERSHING TRANSPORTABILITY STUDY,

Calculations and Analysis of

Railway Tests

Volume I of IV

July 1966

Prepared by

John H. Crier

U.S. ARMY TRANSPORTATION ENGINEERING AGENCY
Fort Eustis, Virginia

CONTENTS

	<u>Page</u>
ABSTRACT	1
I. INTRODUCTION	2
II. OBJECTIVES	3
III. CONCLUSIONS	3
IV. RECOMMENDATIONS	3
V. GENERAL	4
Analysis of Restraining Arrangements, CONUS Study	4
Analysis of Transport Systems, Foreign Railcar Versus CONUS Railcar	10
VI. FIELD EVALUATION	20
VII. SELECTED BIBLIOGRAPHY	23
DISTRIBUTION	

ABSTRACT

A stress analysis, based on the test loads imparted to the XM 475 and XM 476 containers in the CONUS railway impact tests, is presented in order to compare the structural adequacy of the two different types of restraining arrangements evaluated in the tests.

Results of the stress analysis, which confirmed the test results, demonstrate that the restraining arrangement used on the XM 475 container is structurally adequate and meets the requirements of TB 55-100; whereas, the arrangement used on the XM 476 container is not structurally adequate and does not meet the requirements.

Mathematical energy relationships were computed and used as a basis for comparing impact loads to the cargo in the CONUS and foreign railway tests.

The impact calculations verify the test results which show that railcar impact loads to the cargo are more severe for foreign railcars than for CONUS railcars at similar impact velocities.

I. INTRODUCTION

A need for improved restraining systems for Pershing missile containers in rail transit arose shortly after initial shipments; therefore, studies, trials, and improvisations involving rail impact tests were immediately implemented.

CONUS railcar impact tests disclosed many previously undetected factors. Metal straps and cables for vertical restraint were found to be substantially the same if properly designed. Forklift pocket dimensions proved extremely critical when used in conjunction with the standard tiedown arrangements. Other construction factors and shock and vibration characteristics both detrimental and practical were disclosed by the tests.

Tests on foreign railcars were conducted because of the numerous mechanical differences (coupling arrangements, car weights) between foreign- and U.S.-manufactured cars. These tests produced quantitative measurements for assessing the difference in their shock and vibration. New restraining systems developed for CONUS railcars were found to be equally as sound and advantageous for foreign railcars.

To obtain the maximum gain from the two sets of test data, a depth analysis for comparison and study of both systems was initiated. Results of the impact tests are contained in the PERSHING TRANSPORTABILITY STUDY, CONUS Railways, Volume II, and Foreign Railways, Volume III. The studies reported herein surpass test considerations and group both tests for better calculation and analytical comparison.

II. OBJECTIVES

1. To analyze stresses based on test loads and to calculate margins of safety for the restraining arrangements tested.
2. To calculate and evaluate mathematical energy relationships for the items subjected to elastic impact to yield practical criteria factors.

III. CONCLUSIONS

1. The restraining arrangement shown in Figure 1 does not exceed the yield strength of the material during a 10-mile-per-hour impact (hence complying with TB 55-100), whereas the system shown in Figure 2 does exceed the yield strength, as substantiated by both calculations and tests. Foreign rail calculates to satisfy the yield requirement.
2. The elastic impact calculations verify the test results which show that railcar impact loads to the cargo are more severe for foreign railcars than for CONUS railcars at similar impact velocities.

IV. RECOMMENDATIONS

1. That the Figure 1 restraining arrangement be used on the XM 474, XM 475, and XM 476 Pershing missile containers both for CONUS and foreign rail shipments.
2. That calculations, analyses, and tests of restraining systems for foreign railcars be as thorough as for CONUS railcars since high dynamic cargo loadings are experienced in both shipments.

V. GENERAL

ANALYSIS OF RESTRAINING ARRANGEMENTS, CONUS STUDY

The major input force which would knock the railcar from under the container is the longitudinal component of the impact force. The transverse and vertical components are relatively minor; therefore, if the restraining arrangement can adequately resist the longitudinal component, it should be satisfactory.

Restraining Arrangement for XM 476 Container

The input force to the railcar was determined by a dynamometer coupler, and the container response was measured by a strain gage accelerometer oriented to the longitudinal plane. Since the end blocking, Item A in the next figure, was crushed at an impact velocity of 8.9 miles per hour, the input force to the container was, in effect, attenuated, causing the accelerometer to indicate a lower acceleration than would have occurred had the blocking not failed. In view of this, the coupler force is used to analyze the forces acting on the container and unit stress on the blocking.

Coupler force at 8.9 miles per hour was 835,000 pounds.

	<u>Pounds</u>
Railcar weight	68,090
XM 475 container	9,110
XM 476 container	7,322
XM 474 container	<u>2,511</u>
Gross weight, loaded car	87,033

Impact Force Distribution (Assumed Proportional to Masses):

Car + XM 475 + XM 474

$$\frac{79,711 \text{ lb}}{87,033 \text{ lb}} \times 835,000 \text{ lb} = 765,000 \text{ lb}$$

XM 476

$$\frac{7,322 \text{ lb}}{87,033 \text{ lb}} \times 835,000 \text{ lb} = 70,000 \text{ lb}$$

External Forces at Impact on XM 476 Container:

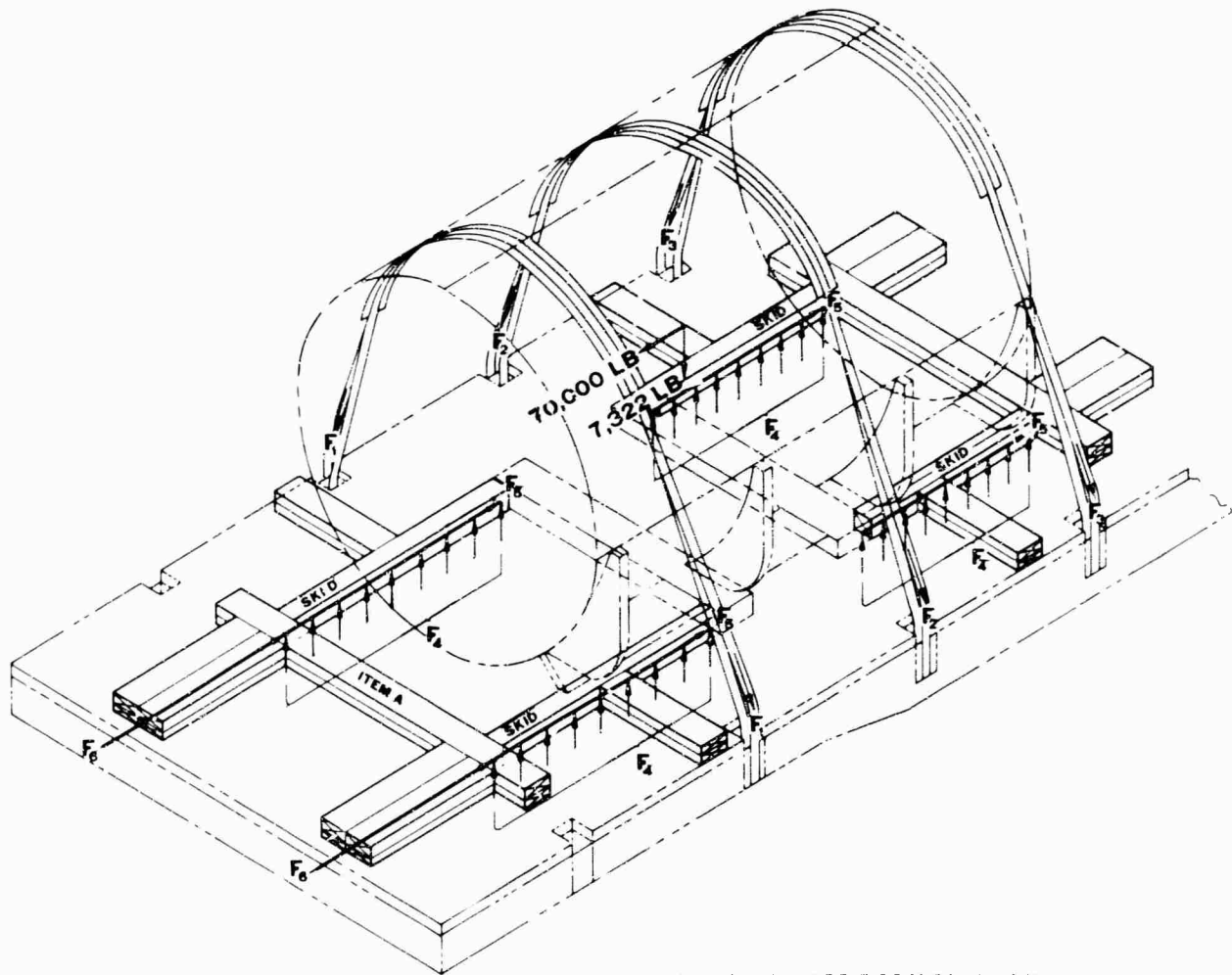

ISOMETRIC FREE BODY DIAGRAM

F_1, F_2, F_3 = Prestress on steel straps (both sides of container). The exact prestress is not known. Prestress will be relieved as car is subjected to impacts. Prestress is assumed to be not less than 500 pounds per end of each strap: total force contributing to friction resistance between bottom of skids and car floor = 3,000 pounds.

F_4 = Floor reaction.

F_5 = Force of friction between container skids and car floor.
(f , oak on oak, in motion = 0.48).

F_6 = Blocking force.

F_L = Longitudinal forces.

$$F_4 = (7,322 \text{ lb} + 3,000 \text{ lb}) = 10,322 \text{ lb}$$

$$F_5 = 0.48(10,322 \text{ lb}) = 4,950 \text{ lb}$$

$$\Sigma F_L = 70,000 \text{ lb} - F_5 - F_6 = 0$$

$$F_6 = 70,000 \text{ lb} - 4,950 \text{ lb} = 65,050 \text{ lb}$$

Unit Stress (Perpendicular to Grain) on Blocking:

Area of end of skid = 12.2 sq in.

$$f = \frac{65,050 \text{ lb}}{2(12.2) \text{ sq in.}} = 2,665 \text{ lb/sq in.}$$

Restraining Arrangement for XM 475 Container:

The basic difference between the arrangement used on the XM 476 container and the one used on the XM 475 is that a much larger bearing area (which distributes the longitudinal force over a larger area of blocking) is provided on the XM 475. The following figures show the relative areas provided by the two arrangements.

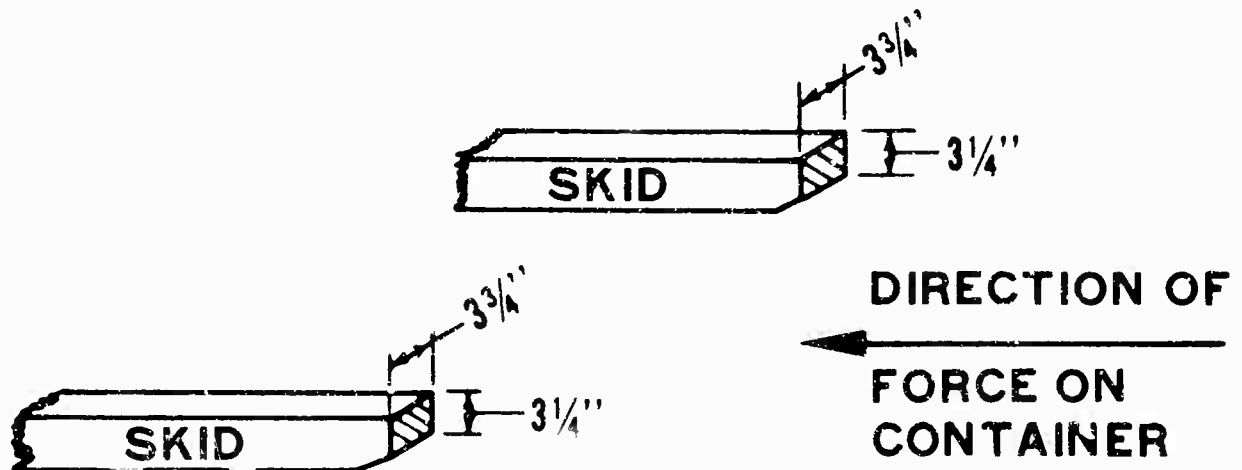

**BEARING AREA PROVIDED BY THE
FIGURE 2 RESTRAINING ARRANGEMENT
(USED ON XM476 CONTAINER)
TOTAL AREA = 2 (3.75"X3.25") = 24.4 SQ IN**

SECTION PROPERTIES, XM 476 ARRANGEMENT

SECTION PROPERTIES, XM 475 ARRANGEMENT

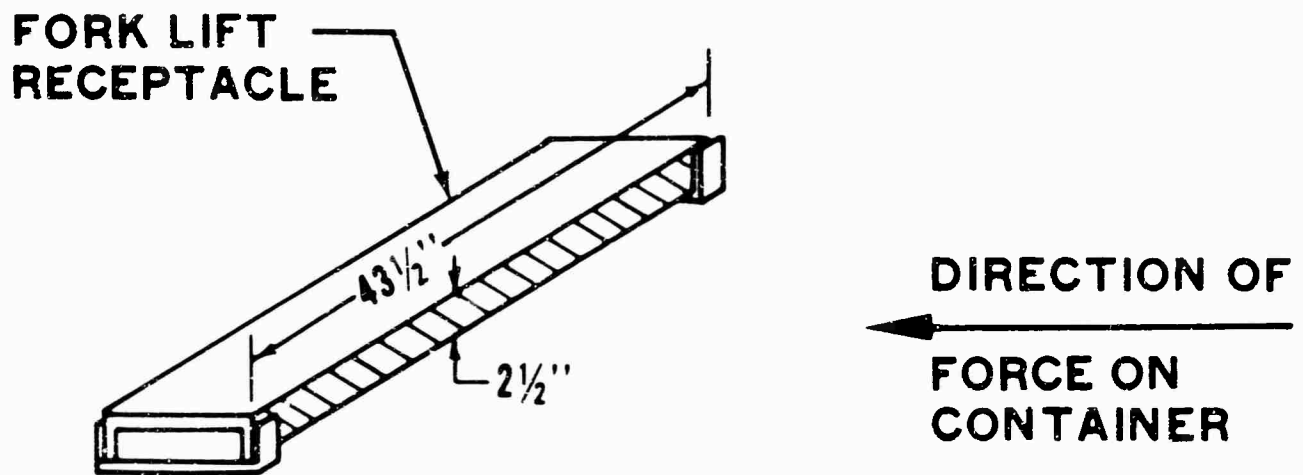

**BEARING AREA PROVIDED BY THE
FIGURE 1 RESTRAINING ARRANGEMENT
(USED ON THE XM475 CONTAINER)
TOTAL AREA = 2.5"X43.5" = 108.75 SQ IN**

The same procedure used to determine the unit stress on the blocking in the XM 476 arrangement was used to determine the unit stress on the blocking in the XM 475 arrangement.

Portion of Impact Force Imparted to XM 475:

$$\frac{9,110 \text{ lb}}{87,033 \text{ lb}} \times 835,000 \text{ lb} = 87,500 \text{ lb}$$

External Forces at Impact on XM 475 Container:

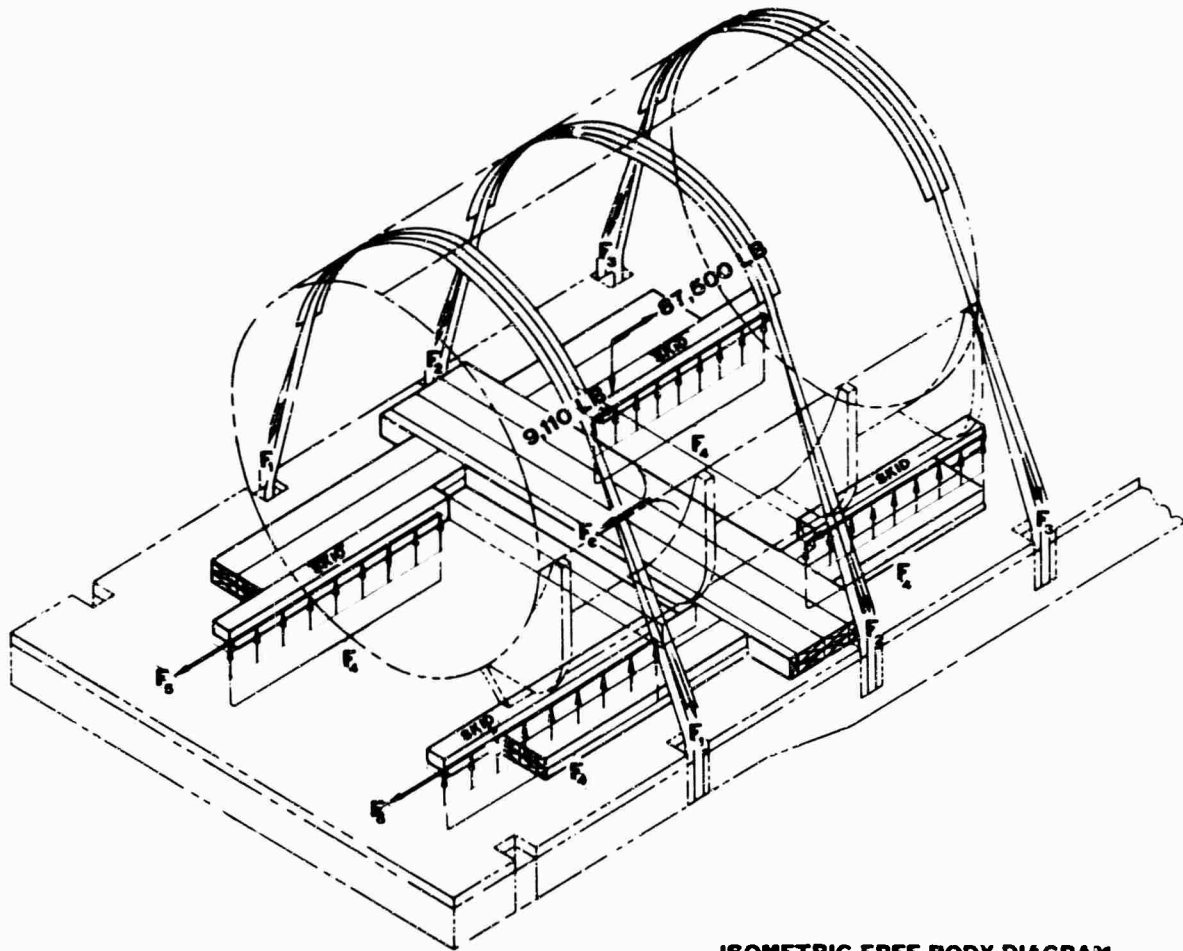

ISOMETRIC FREE BODY DIAGRAM

$$F_4 = 9,110 \text{ lb} + 3,000 \text{ lb} = 12,110 \text{ lb}$$

$$F_5 = 0.48(12,110 \text{ lb}) = 5,820 \text{ lb}$$

$$\Sigma F_L = 87,500 \text{ lb} - F_5 - F_6 = 0$$

$$F_6 = 87,500 \text{ lb} - 5,820 \text{ lb} = 81,680 \text{ lb}$$

Unit Stress (Perpendicular to Grain) on Blocking:

Area across forklift receptacle = 108.75 sq in.

$$f = \frac{81,680 \text{ lb}}{108.75 \text{ sq in.}} = 750 \text{ lb/sq in.}$$

Strength Characteristics

The strength in compression perpendicular to the grain, fiber stress at the proportional limit for short-time loading (a few minutes) for southern yellow pine, varies from 440 to 1,390 pounds per square inch, depending on the species and its moisture content. (Since load duration was less than 1 second, the ultimate strength would be greater; however, information is not readily available on extremely short load durations applied perpendicularly to the grain.)

The timber used for blocking was No. 2 grade southern yellow pine. Since it was relatively dry, its ultimate compressive strength, perpendicular to the grain, was approximately 1,400 pounds per square inch.

The stress that caused failure of the blocking in the XM 476 arrangement (2,665 pounds per square inch) was some two times as great as the strength of the timber.

The blocking arrangement used on the XM 475 sustained the applied load since the unit stress on the timber amounted to only 54 percent of its expected strength in compression perpendicular to the grain.

The blocking arrangement used on the XM 476 container sustained impacts of up to 8 miles per hour without significant damage, but failed under a 9-mile-per-hour impact. Thus, at impact velocities of 8 miles per hour, the blocking arrangement is apparently marginal.

At an impact velocity of 10 miles per hour, the blocking used on the XM 475 container is subjected to 61 percent of its expected strength in compression perpendicular to the grain; consequently, the arrangement is not overdesigned based on the theoretical analysis.

Test Results

The restraining arrangement used on the XM 476 containers (Figure 2) did not sustain the applied dynamic loadings. At an impact velocity of 8.9 miles per hour, the transverse blocking member was severely crushed by the ends of the container skids. During the following impact, at 10.4 miles per hour, the member failed completely. There was no apparent damage to the container skids. Prior to the failure, the restraining arrangement used on the XM 476 container sustained eight impacts varying in impact velocity from 3.5 to 8 miles per hour.

The restraining arrangement used on the XM 474 and XM 475 containers (illustrated in Figure 1) sustained the applied dynamic loadings.

The XM 476 container is similar in geometry and construction to the XM 475 container; consequently, the restraining arrangement used on the XM 475 (Figure 1) is applicable to the XM 476 container.

Advantages of the Figure 1 Arrangement Over the Figure 2 and Other Arrangements Currently Being Used

The restraining arrangement shown in Figure 1 is applicable to all three containers. Because of its simplicity, the entire restraining arrangement (with details) can be clearly illustrated on one 8-inch by 10½-inch sheet of paper. Other significant advantages are as follows:

1. Prepositioning of the transverse blocking is not required, since no nails are required under the container.
2. Less longitudinal space on the car is required.
3. The longitudinal blocking members also provide transverse restraint, which simplifies the arrangement.

ANALYSIS OF TRANSPORT SYSTEMS, FOREIGN RAILCAR VS CONUS RAILCAR

Theoretical Considerations

A comparison, as illustrated in Table 1, of the kinetic energy of the hammer cars in the two tests at an impact velocity of 8 miles per hour shows that the ratio of the input kinetic energy per kip of test car weight was 17.5 percent greater in the foreign railcar test.

TABLE I
KINETIC ENERGY INPUT
AT IMPACT VELOCITY OF 8 MILES PER HOUR

	Foreign Railcar	CONUS Railcar
Weight of Hammer Car	108,000 lb	169,000 lb
Weight of Test Car	47,400 lb	87,033 lb
Kinetic Energy = $\frac{1}{2} \left(\frac{WV^2}{g} \right)$	231,500 ft-lb	362,000 ft-lb
Input Energy per Pound of Test Car Weight	4.89 ft-lb	4.16 ft-lb

The following calculations demonstrate the high energy-absorbing capability of the relatively heavy CONUS railcars. The energy loss during the compression phase of the impact was 70,200 foot-pounds in the foreign railcar test; whereas, in the CONUS test it was 122,000 foot-pounds.

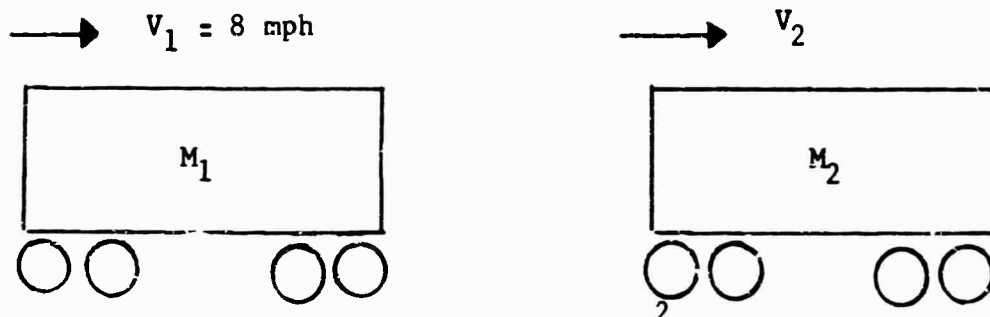

$$\text{KE Before Impact} = \frac{M_1 v_1^2}{2} \quad (1)$$

$$M_1 v_1 = (M_1 + M_2) v_2$$

$$v_2 = \frac{M_1 v_1}{M_1 + M_2}$$

$$v = \left(\frac{M_1}{M_1 + M_2} \right)^2 v_1^2 \quad (2)$$

$$\text{KE After Compression Phase of Impact} = \frac{(M_1 + M_2) v_2^2}{2} \quad (3)$$

$$\text{KE Loss During Compression Phase of Impact} = \frac{M_1 v_1^2}{2} - \frac{(M_1 + M_2) v_2^2}{2}$$

Substitute Eq. (2)

$$\text{KE Loss During Compression Phase of Impact} = \left(M_1 - \frac{M_1^2}{M_1 + M_2} \right) \frac{v_1^2}{2} \quad (4)$$

Foreign Test

$$\left[\frac{108,000}{32.2} - \frac{\left(\frac{108,000}{32.2} \right)^2}{\frac{108,000}{32.2} + \frac{47,400}{32.2}} \right] \frac{(11.7)^2}{2} = 70,200 \text{ ft-lb}$$

CONUS Test

$$\left[\frac{169,000}{32.2} - \frac{\left(\frac{169,000}{32.2} \right)^2}{\frac{169,000}{32.2} + \frac{87,033}{32.2}} \right] \frac{(11.7)^2}{2} = 122,000 \text{ ft-lb}$$

The effect of the greater energy input per pound of test car weight in the foreign rail test and the higher energy-absorbing capability of the CONUS railcars resulted in higher accelerations on the railcar in the foreign rail test. The theoretical acceleration (Table II) of the entire mass is 12.4g for the foreign service test car and 8.5g for the CONUS test car.

TABLE II
FORCE - INERTIA RELATIONS
AT IMPACT VELOCITY OF 8 MILES PER HOUR

	Foreign Railcar	CONUS Railcar
Coupler Force	588,000 lb	739,000 lb
Weight of Test Car	47,400 lb	87,033 lb
Acceleration = $\frac{FG}{W}$	12.4g	8.5g

From the above analysis, it is apparent that Army materiel may be subjected to a more severe shock and vibration environment on foreign railcars. Whether the environment will be more severe depends on the relative weights of the cars involved and mechanical differences in car configuration.

Test Results

The theoretical analysis verifies the test results as evidenced by the test data in Table III.

TABLE III
LONGITUDINAL ACCELERATION

Location	Speed (mph)	CONUS Railcar		Foreign Railcar	
		Ampli.	Dura.	Ampli.	Dura.
Car Floor	8	21.7g	20-70 ms	49.8g	8-25 ms
Exterior Con- tainer XM 475	8	16.3g	25-65 ms	19.5g	18-45 ms
Interior Car- riage XM 475	8	15.3g	24-170 ms	16.8g	20-60 ms
Coupler Impact Force	8	739 kips	116 ms	588 kips	8-40 ms

Figure 3 is a comparison of the input forces (coupler force in the CONUS railcar test versus buffer forces in the foreign railcar test).

A comparison of the longitudinal peak accelerations on the car floor and on the exterior and interior of the containers (CONUS test versus foreign test) (Figures 4 through 6) shows that accelerations were greater on the foreign railcar. The car floor accelerations were more than twice as great. The accelerations on the exterior and interior of the XM 475 container were significantly higher. The higher accelerations on the foreign railcar are due to its relatively light weight. (There is not as much mass to absorb the energy developed at impact.) A comparison of the vertical and transverse accelerations revealed similar results.

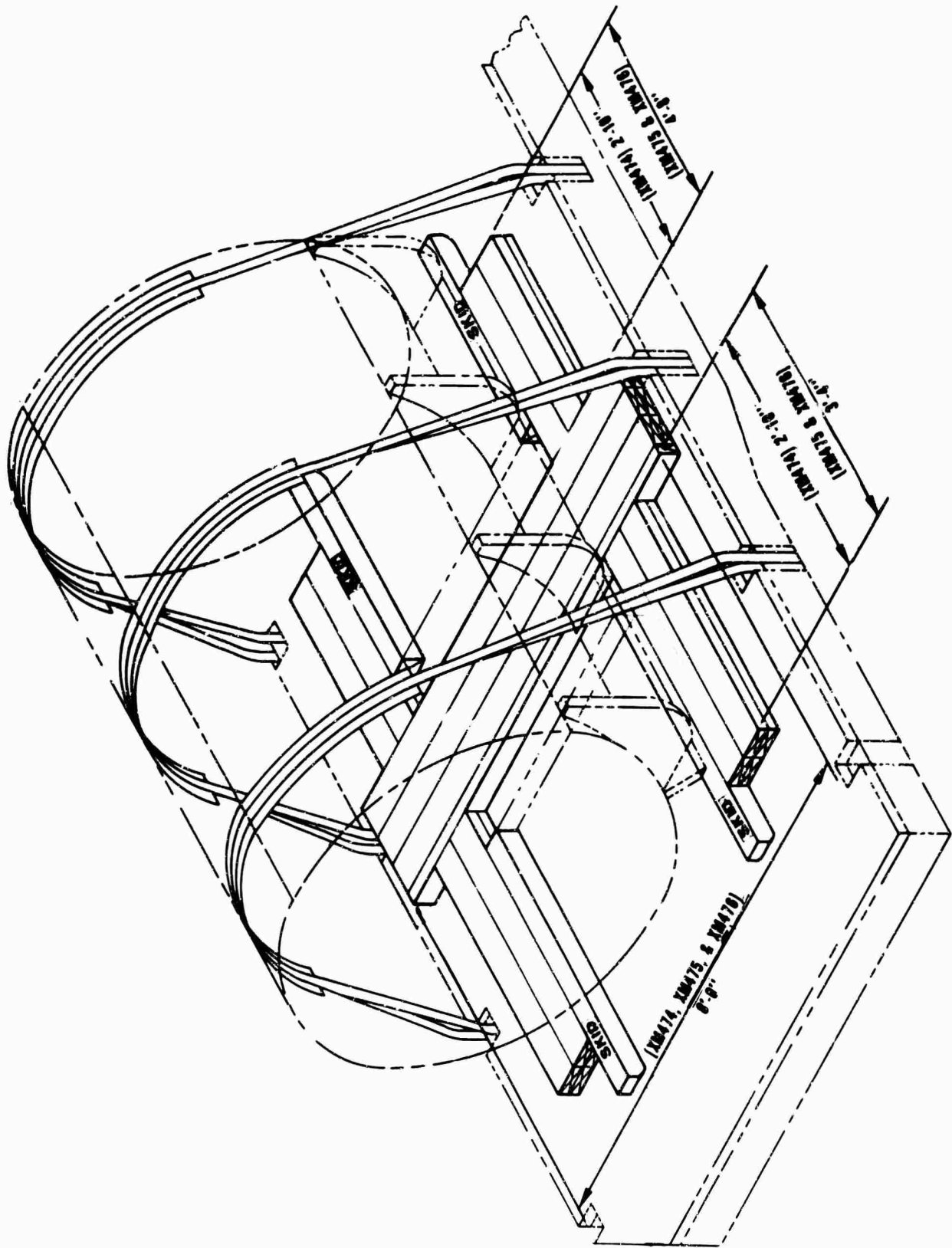

Figure 1. Restraining Arrangement Used on XM 474 and XM 475 Containers.

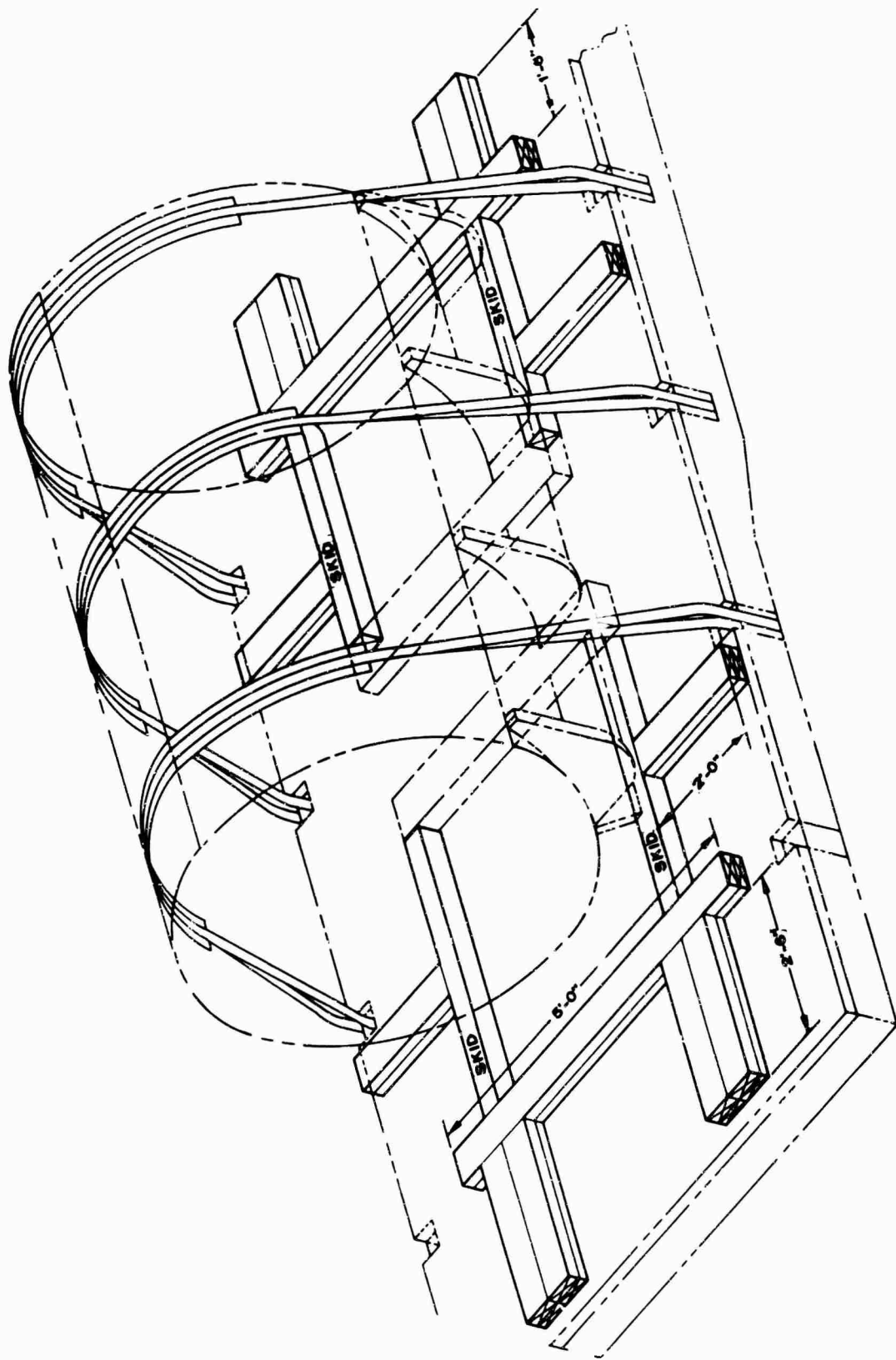

Figure 2. Restraining Arrangement Used on XM 476 Container.

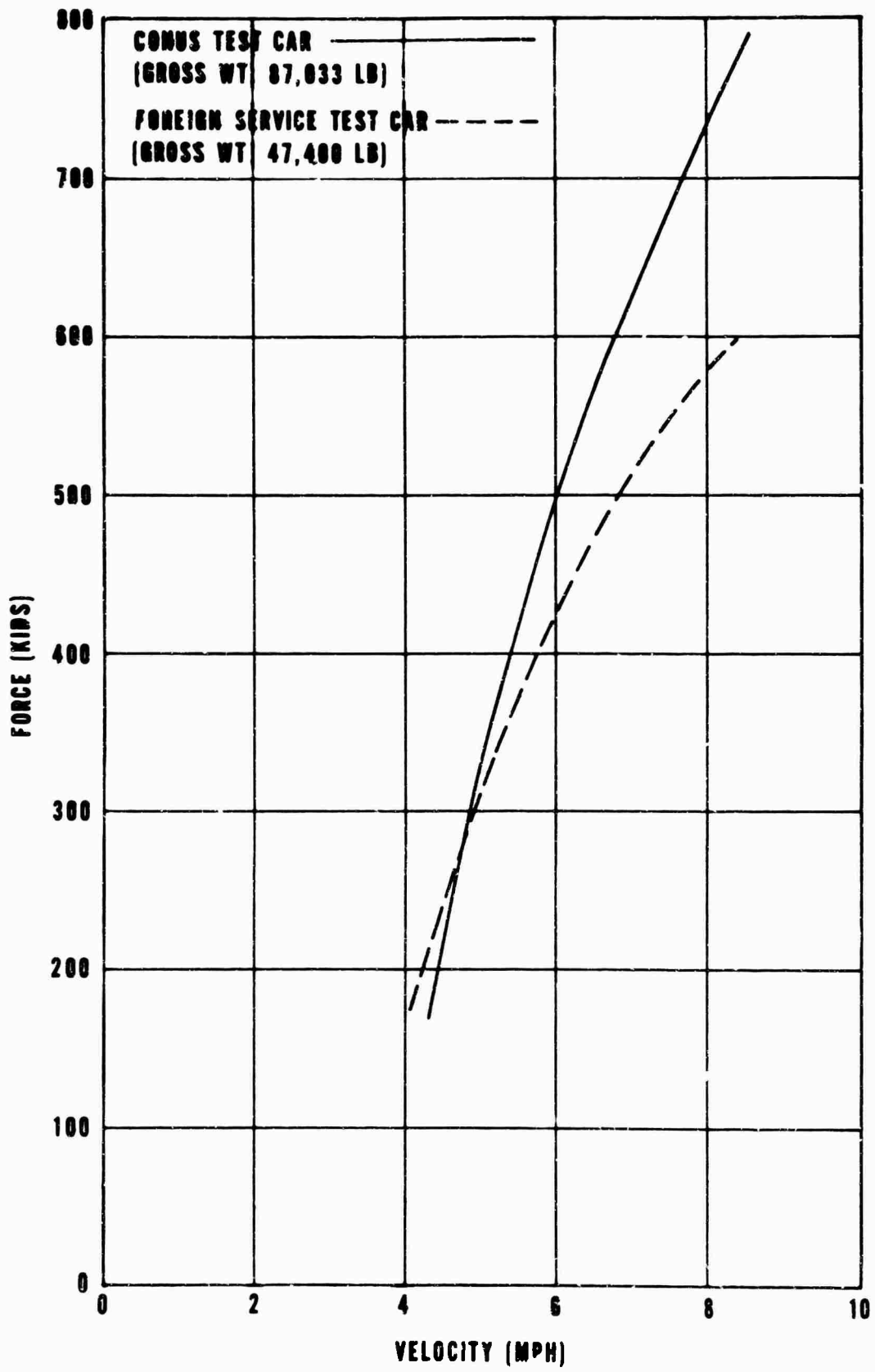

Figure 3. Coupler Force Versus Buffer Force on CONUS and Foreign Service Railcars.

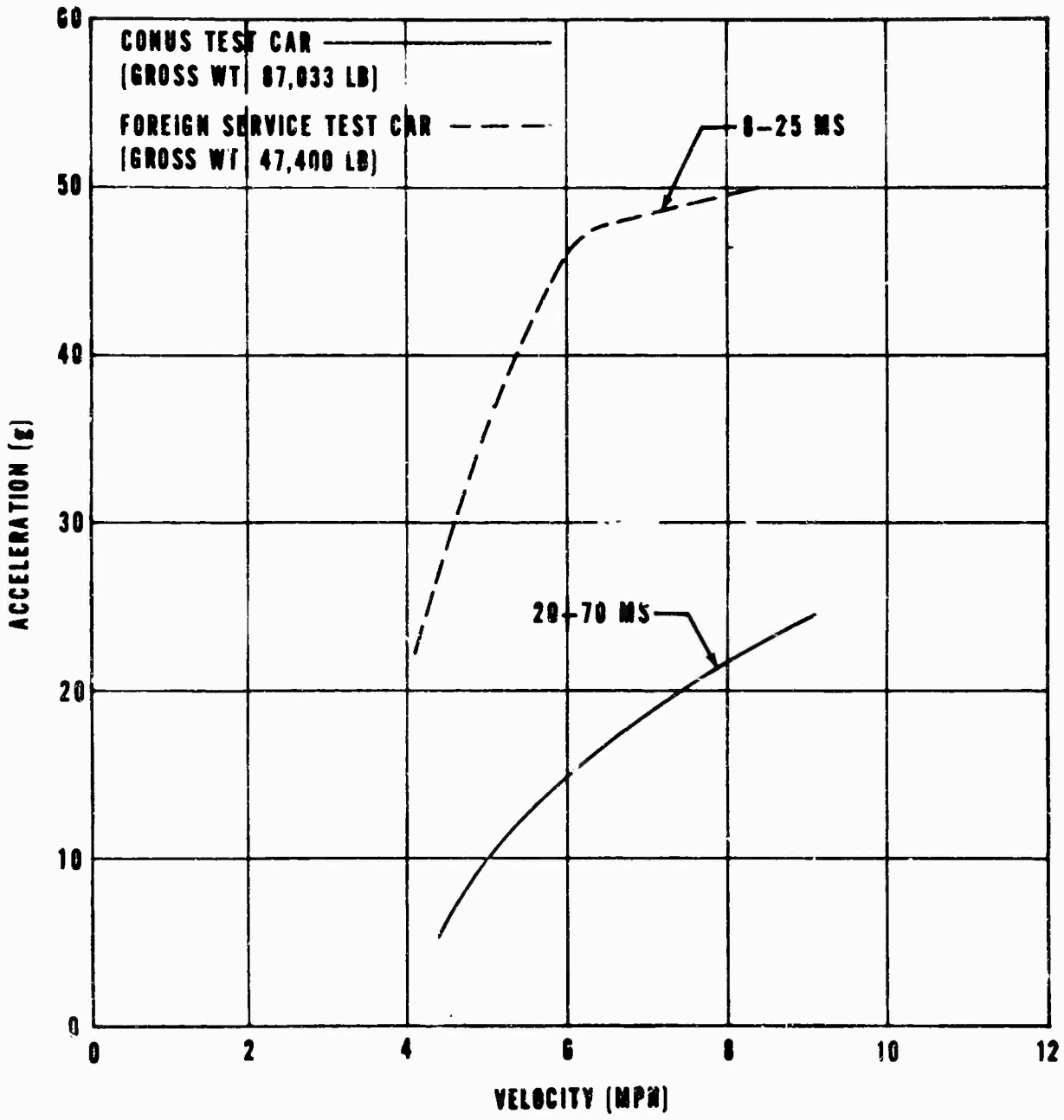

Figure 4. Longitudinal Accelerations on Car Floor:
CONUS Versus Foreign Service Railcars.

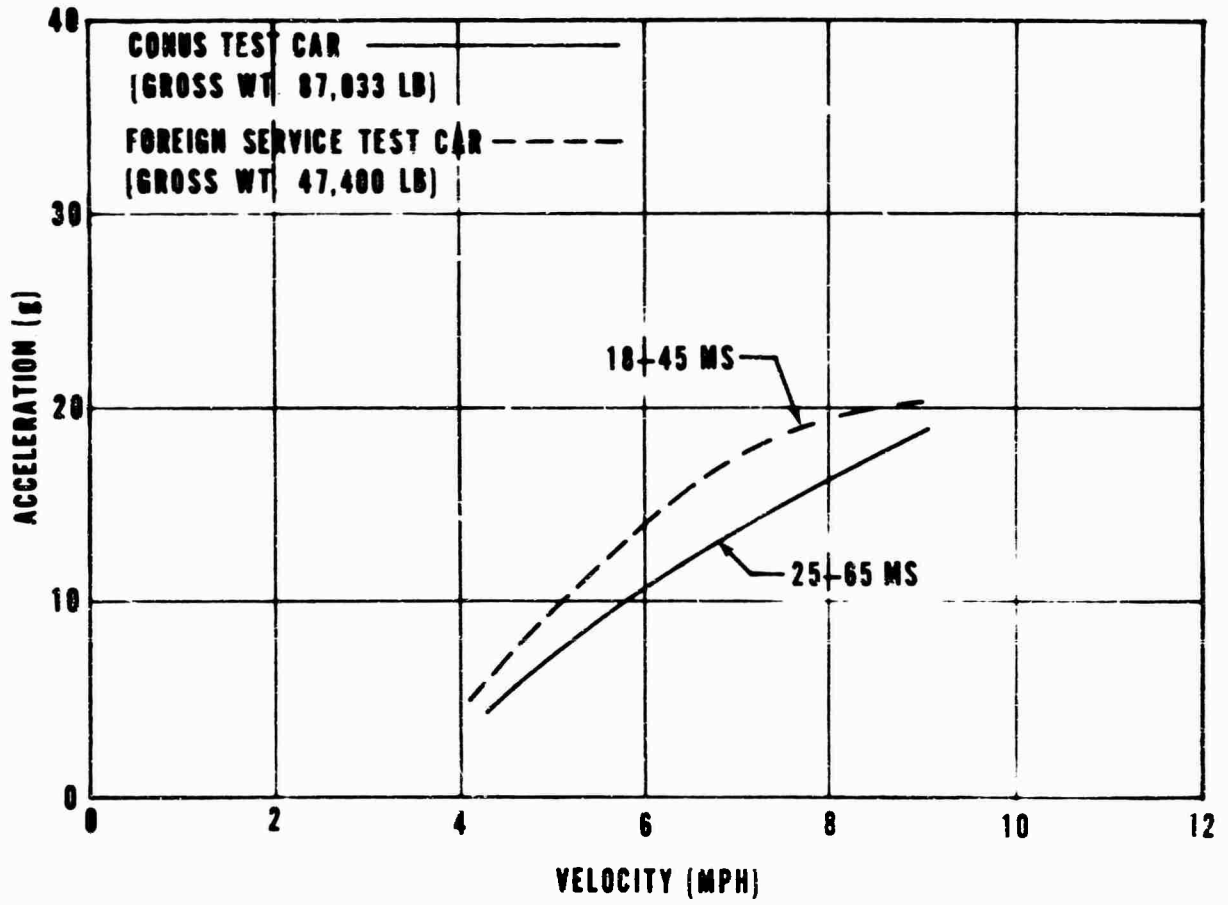

Figure 5. Longitudinal Accelerations on Exterior of XM 475: CONUS Versus Foreign Service Railcars.

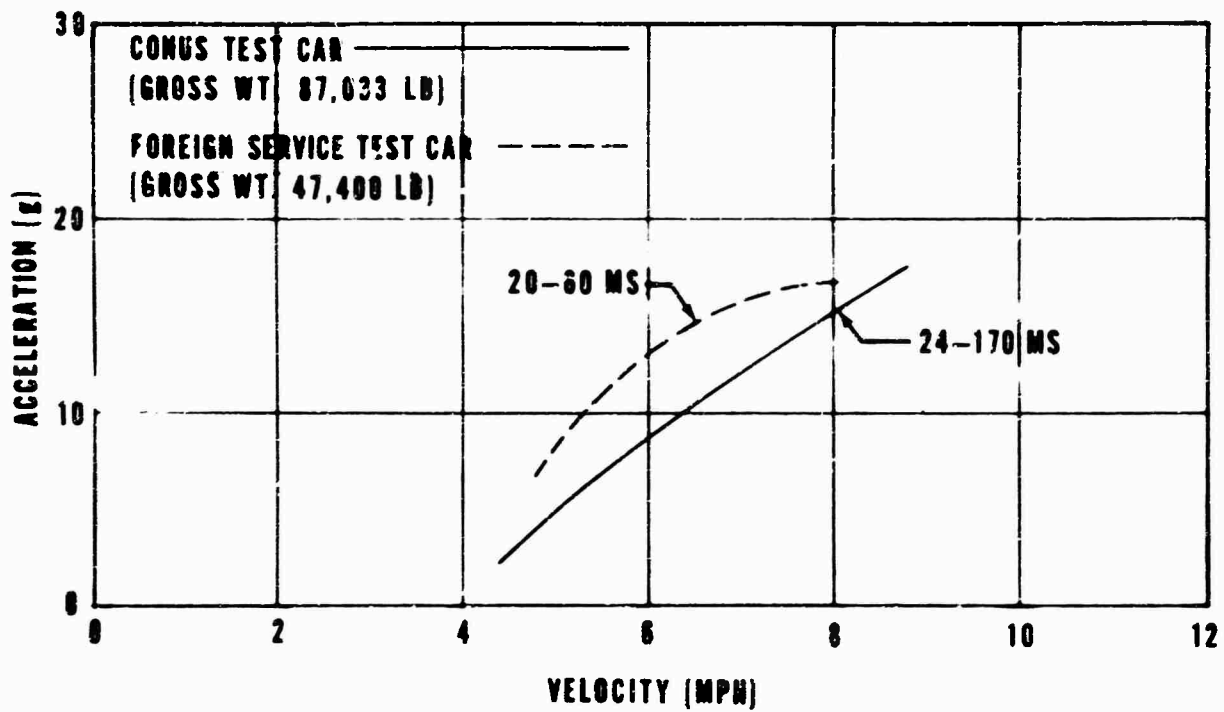

Figure 6. Longitudinal Accelerations on Interior of XM 475: CONUS Versus Foreign Service Railcars.

VI. FIELD EVALUATION

GENERAL

Loading and restraining arrangements developed for the shipment of Pershing missile system containers XM 474, XM 475, and XM 476 on CONUS railcars are incorporated in a series of Savanna Army Depot drawings. Two of the arrangements for restraining the containers were evaluated in the foreign railway study.

The report concluded that one of the tiedown arrangements, combined with container construction differences, resulted in overloading the skid bolts (when the skid was not abutted against the forklift receptacles), with consequent failure during railcar impacts of 6- to 7-mile-per-hour velocities. To correct this deficiency, a modified restraining arrangement was developed during the study. The report recommended that the modified arrangement, referred to as the "Distributed Uniform Loading Arrangement" and illustrated in Figure 1, be adopted for foreign railway movement, and that the arrangement be further evaluated for CONUS railway movement.

Also, the study would evaluate the possibility of establishing a common restraint arrangement for CONUS and foreign rail movement.

DESCRIPTION OF EQUIPMENT

Three Research and Development containers, XM 474, XM 475, and XM 476 were used in the study. Figure 7 shows the containers loaded on one of the test cars. Other Pershing missile containers have a similar geometry and construction; therefore, the results of the study are equally applicable to them, except for correlating the spring constants between the Research and Development container and the production model.

INSTRUMENTATION

The electronic instrumentation for the containers and railcars was identical in both the foreign and CONUS railway studies, except that due to car configuration, where two load cells were required to measure the input force to the foreign service car, only the coupler had to be instrumented on the CONUS railcars.

RAIL IMPACT PROCEDURES

The relative positioning of the test equipment (hammer car, test car, and backup cars) for the railcar impacts was identical in the foreign and CONUS railway studies. In performing all impacts, the test car was stationary and free to roll. The hammer car was accelerated and impacted into the test car.

Prior to the CONUS study, the containers were examined to determine the extent of damage to forklift receptacles, skids, and skid bolts.

Damage to the forklift receptacles that occurred on the XM 476 container during the vessel stowage static study was repaired, damaged skid bolts were replaced, and all skids were abutted against the forklift receptacles.

The XM 474 and XM 475 containers were restrained as shown in Figure 1. In some tests, the XM 474 and XM 476 containers were restrained as indicated in Figure 2.

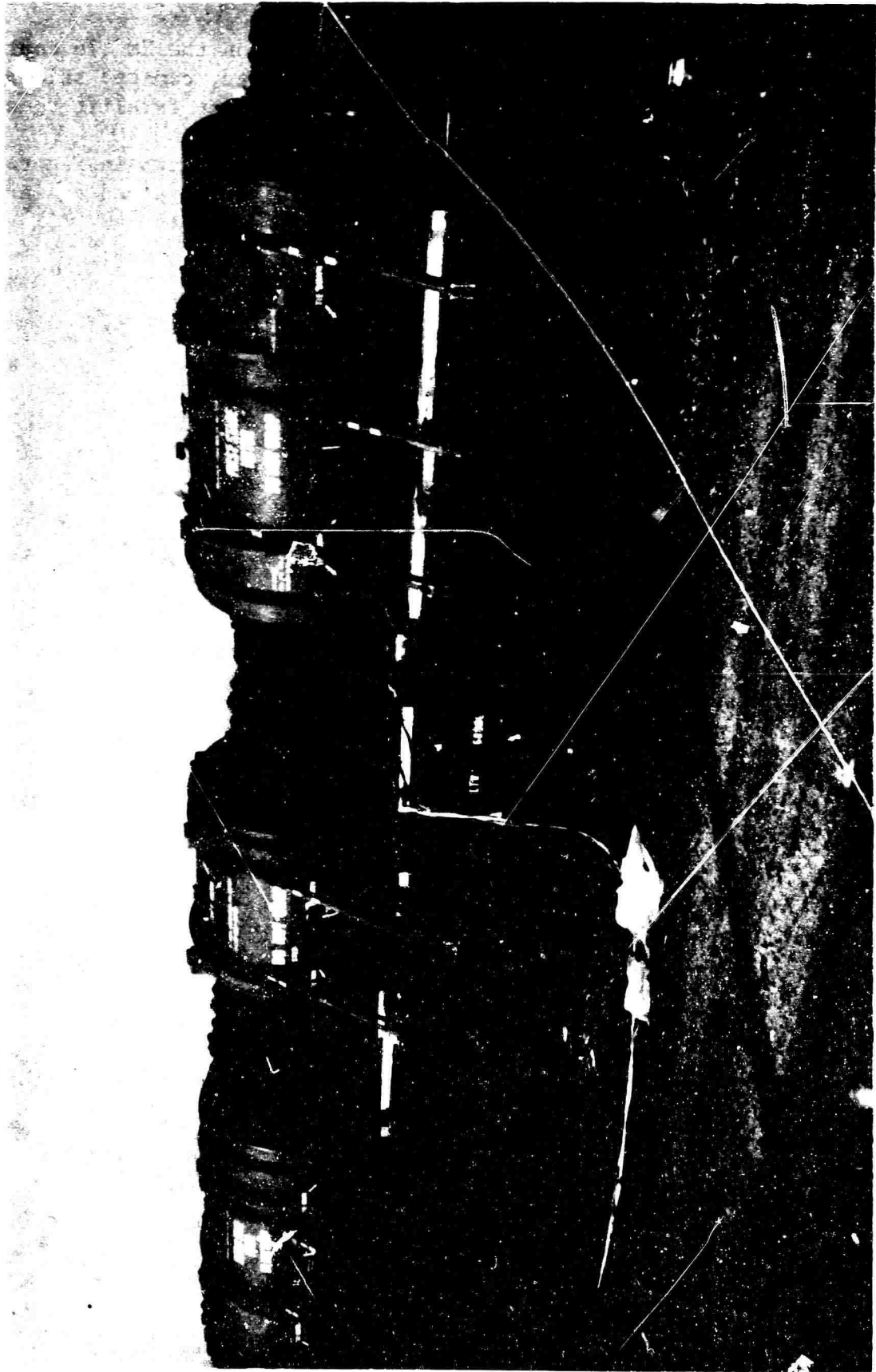

Figure 7. Loaded Test Car.

VII. SELECTED BIBLIOGRAPHY

TB 55-100, Transportability Criteria - Shock and Vibration, Department of the Army, Washington, D.C., 17 April 1964.

Engineering Report, USATEA Report 66-11, PERSHING TRANSPORTABILITY STUDY, Foreign Railways, Vol. III, U.S. Army Transportation Engineering Agency, Fort Eustis, Virginia, July 1966.

Engineering Report, USATEA Report 66-11, PERSHING TRANSPORTABILITY STUDY, CONUS Railways, Vol. II, U.S. Army Transportation Engineering Agency, Fort Eustis, Virginia, July 1966.

UNCLASSIFIED

Security Classification

DOCUMENT CONTROL DATA - R&D		
<i>(Security classification of title, body of abstract and indexing annotation must be entered when the overall report is classified)</i>		
1. ORIGINATING ACTIVITY (Corporate author) U.S. Army Transportation Engineering Agency Fort Eustis, Va.		2a. REPORT SECURITY CLASSIFICATION Unclassified
		2b. GROUP
3. REPORT TITLE PERSHING TRANSPORTABILITY STUDY, Calculations and Analysis of Railway Tests, Vol. I of IV.		
4. DESCRIPTIVE NOTES (Type of report and inclusive dates)		
5. AUTHOR(S) (Last name, first name, initial) Grier, John H.		
6. REPORT DATE July 1966	7a. TOTAL NO OF PAGES 23	7b. NO. OF REFS 6
8a. CONTRACT OR GRANT NO.	9a. ORIGINATOR'S REPORT NUMBER(S) USATEA Report 66-11	
a. PROJECT NO.		
c.	9b. OTHER REPORT NO(S) (Any other numbers that may be assigned this report)	
d.		
10. AVAILABILITY/LIMITATION NOTICES Distribution of this document is unlimited.		
11. SUPPLEMENTARY NOTES		12. SPONSORING MILITARY ACTIVITY
13. ABSTRACT A stress analysis, based on the test loads imparted to the XM 475 and XM 476 containers in the CONUS railway impact tests, is presented in order to compare the structural adequacy of the two different types of restraining arrangements evaluated in the tests. Results of the stress analysis, which confirmed the test results, demonstrate that the restraining arrangement used on the XM 475 container is structurally adequate and meets the requirements of TB 55-100; whereas, the arrangement used on the XM 476 container is not structurally adequate and does not meet the requirements. Mathematical energy relationships were computed and used as a basis for comparing impact loads to the cargo in the CONUS and foreign railway tests. The impact calculations verify the test results which show that railcar impact loads to the cargo are more severe for foreign railcars than for CONUS railcars at similar impact velocities.		

DD FORM 1473
1 JAN 64

UNCLASSIFIED

Security Classification

<p align="center">14. KEY WORDS</p> <p align="center">Shock and Vibration</p> <p align="center">Comparison of Shock Loadings, COMUS</p> <p align="center">Vs Foreign Rail</p>	LINK A		LINK B		LINK C	
	ROLE	WT	ROLE	WT	ROLE	WT

INSTRUCTIONS

1. **ORIGINATING ACTIVITY:** Enter the name and address of the contractor, subcontractor, grantee, Department of Defense activity or other organization (*corporate author*) issuing the report.

2a. **REPORT SECURITY CLASSIFICATION:** Enter the overall security classification of the report. Indicate whether "Restricted Data" is included. Marking is to be in accordance with appropriate security regulations.

2b. **GROUP:** Automatic downgrading is specified in DoD Directive 5200.10 and Armed Forces Industrial Manual. Enter the group number. Also, when applicable, show that optional markings have been used for Group 3 and Group 4 as authorized.

3. **REPORT TITLE:** Enter the complete report title in all capital letters. Titles in all cases should be unclassified. If a meaningful title cannot be selected without classification, show title classification in all capitals in parenthesis immediately following the title.

4. **DESCRIPTIVE NOTES:** If appropriate, enter the type of report, e.g., interim, progress, summary, annual, or final. Give the inclusive dates when a specific reporting period is covered.

5. **AUTHOR(S):** Enter the name(s) of author(s) as shown on or in the report. Enter last name, first name, middle initial. If military, show rank and branch of service. The name of the principal author is an absolute minimum requirement.

6. **REPORT DATE:** Enter the date of the report as day, month, year, or month, year. If more than one date appears on the report, use date of publication.

7a. **TOTAL NUMBER OF PAGES:** The total page count should follow normal pagination procedures, i.e., enter the number of pages containing information.

7b. **NUMBER OF REFERENCES:** Enter the total number of references cited in the report.

8a. **CONTRACT OR GRANT NUMBER:** If appropriate, enter the applicable number of the contract or grant under which the report was written.

8b, 8c, & 8d. **PROJECT NUMBER:** Enter the appropriate military department identification, such as project number, subproject number, system numbers, tank number, etc.

9a. **ORIGINATOR'S REPORT NUMBER(S):** Enter the official report number by which the document will be identified and controlled by the originating activity. This number must be unique to this report.

9b. **OTHER REPORT NUMBER(S):** If the report has been assigned any other report numbers (*either by the originator or by the sponsor*), also enter this number(s).

10. **AVAILABILITY/LIMITATION NOTICES:** Enter any limitations on further dissemination of the report, other than those imposed by security classification, using standard statements such as:

- (1) "Qualified requesters may obtain copies of this report from DDC."
- (2) "Foreign announcement and dissemination of report by DDC is not authorized."
- (3) "U. S. Government agencies may obtain copies of this report directly from DDC. Other qualified DDC users shall request through _____."
- (4) "U. S. military agencies may obtain copies of this report directly from DDC. Other qualified users shall request through _____."
- (5) "All distribution of this report is controlled. Qualified DDC users shall request through _____."

If the report has been furnished to the Office of Technical Services, Department of Commerce, for sale to the public, indicate this fact and enter the price, if known.

11. **SUPPLEMENTARY NOTES:** Use for additional explanatory notes.

12. **SPONSORING MILITARY ACTIVITY:** Enter the name of the departmental project office or laboratory sponsoring (*paying for*) the research and development. Include address.

13. **ABSTRACT:** Enter an abstract giving a brief and factual summary of the document indicative of the report, even though it may also appear elsewhere in the body of the technical report. If additional space is required, a continuation sheet shall be attached.

It is highly desirable that the abstract of classified reports be unclassified. Each paragraph of the abstract shall end with an indication of the military security classification of the information in the paragraph, represented as (TS), (S), (C), or (U).

There is no limitation on the length of the abstract. However, the suggested length is from 150 to 225 words.

14. **KEY WORDS:** Key words are technically meaningful terms or short phrases that characterize a report and may be used as index entries for cataloging the report. Key words must be selected so that no security classification is required. Identifiers, such as equipment model designation, trade name, military project code name, geographic location, may be used as key words but will be followed by an indication of technical context. The assignment of links, rules, and weights is optional.