

AD

USATEA Report 66-11

Engineering Report

PERSHING TRANSPORTABILITY STUDY

Vessel Stowage, Vol. IV of IV

July 1966

AD635243



CLEARINGHOUSE
FOR FEDERAL SCIENTIFIC AND
TECHNICAL INFORMATION

Hardcopy	Microfiche
\$ 2.00	.50 30

1 ARCHIVE COPY

DDC
RECEIVED
JUL 18 1966

U. S. ARMY
TRANSPORTATION ENGINEERING AGENCY
FORT EUSTIS, VIRGINIA

DISCLAIMER NOTICE

The findings in this report are not to be construed as an official Department of the Army position unless so designated by other authorized documents.

DDC AVAILABILITY NOTICE

Distribution of this document is unlimited.

DISPOSITION INSTRUCTIONS

Destroy this report when no longer needed. Do not return it to the originator.

ACCESSION for	
W. I. T. SECTION <input checked="" type="checkbox"/>	DDC <input type="checkbox"/>
UNANNOUNCED	DDC SECTION <input type="checkbox"/>
JUSTIFICATION <i>for statement on doc</i>	
BY <i>pm</i>	
DISTRIBUTION/AVAILABILITY CODES	
DIST.	AVAIL. and/or SPECIAL
<i>1</i>	

DISCLAIMER NOTICE

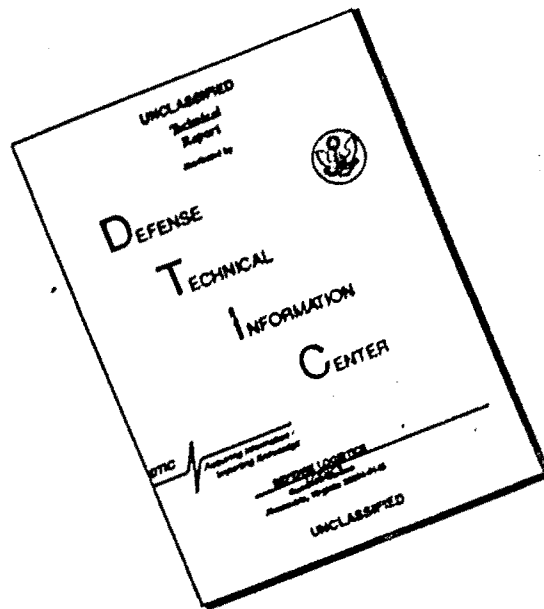

THIS DOCUMENT IS BEST QUALITY AVAILABLE. THE COPY FURNISHED TO DTIC CONTAINED A SIGNIFICANT NUMBER OF PAGES WHICH DO NOT REPRODUCE LEGIBLY.

ENGINEERING REPORT

PERSHING TRANSPORTABILITY STUDY,

Vessel Stowage

Volume IV of IV

July 1966

Prepared by

John H. Grier

U.S. ARMY TRANSPORTATION ENGINEERING AGENCY
Fort Eustis, Virginia

CONTENTS

	<u>Page</u>
LIST OF ILLUSTRATIONS	v
ABSTRACT	1
I. INTRODUCTION	2
II. OBJECTIVE	4
III. CONCLUSIONS	4
IV. RECOMMENDATIONS	4
V. FIELD EVALUATION	6
VI. TRANSPORTATION ENGINEERING ANALYSIS	10
VII. TRANSPORTATION SYSTEM ANALYSIS	21
VIII. REFERENCES	23
DISTRIBUTION	

ILLUSTRATIONS

<u>Figure</u>		<u>Page</u>
1	Research and Development XM 476 Container	7
2	Schematic of Instrumentation	8
3	Schematic of Instrumentation	9
4	Vertical Restraining Arrangement	11
5	Loading Platform on Top of Vertical Members	12
6	17,500-Pound Load in Position	13
7	Longitudinal Restraining Members Under Test	14
8	Test Setup for Longitudinal Loading	15
9	Transverse Restraining Members Under Test	17
10	Test Setup for Transverse Loading	18
11	Channel Sections (Bottom View).	20

ABSTRACT

A vessel stowage static study (a phase of the "Transportability Study on Movement Worldwide of the Pershing Missile System") was conducted on a Pershing missile system second stage motor container, XM 476. The purpose of the study was to evaluate the structural integrity of a proposed procedure for the stowage of an XM 476 and similar containers aboard a vessel subjected to adverse ocean environments, that is, State of Sea, Bowditch Scale 5-7. Dynamic loadings likely to accrue from such an environment were empirically reduced to static criteria and measurement. Other portions of the overall study will obtain actual measurements of the dynamic loading. The applied static loading conditions were (1) 3g vertical, (2) 3g transverse, and (3) 1g longitudinal.

Results of the study showed that the container skids do not have the required structural strength to resist the applied static loading conditions. The proposed stowage plan and restraining procedure proved to be satisfactory in withstanding the applied static loads.

I. INTRODUCTION

During a meeting at Savanna Army Depot, 24-25 June 1965, on "Transportability Criteria," engineers of various Army commands and agencies reviewed problems encountered in the movement, worldwide, of the Pershing missile system.

To determine a more realistic understanding of the problems and their causes, representatives of the Director of Transportation, Office of the Deputy Chief of Staff for Logistics, Department of the Army, and the Pershing Project Office, Redstone Arsenal, Alabama, visited Military Ocean Terminal, Sunny Point, North Carolina, 16-19 August 1965, to observe the outloading of first and second stage motor containers. As a result of this meeting, the following conclusions were reached:

1. A requirement exists to develop shipping standards and procedures, based on scientifically developed transportability criteria, that will provide safe and effective movement and terminal handling of the Pershing missile system worldwide.
2. The Pershing system containers and terminal material handling equipment are not complementary or compatible, consequently resulting in an unsatisfactory stowing condition aboard the vessel.
3. A need exists to develop modern stowing techniques that will reduce dunnage and that will facilitate and expedite the loading of a vessel.
4. The concepts developed for CONUS terminals should be equally applicable to and adaptable for immediate employment in overseas terminals.

In further pursuit, a program to conduct a scientific "Transportability Study on Movement Worldwide of the Pershing Missile System" was prepared. The purpose of this program is to establish transportability criteria that will serve as a basis for developing movement standards and procedures.

A meeting was held in the Office of the Deputy Chief of Staff for Logistics, Transportation Engineering Office (DCSLOG/TENO), 21-22 September 1965, to review, coordinate, and approve the study. Participating agencies included representatives of DCSLOG/TENO; U.S. Army Materiel Command (USAMC); U.S. Army Supply and Maintenance Command (USASMC); Military Traffic Management and Terminal Service (MTMTS); Headquarters, Eastern Area, Military Traffic Management and Terminal Service (HQ, EAMTMS); U.S. Army Missile Command (USAMICOM); and the U.S. Army Transportation Engineering Agency (USATEA). Upon approval, USATEA was instructed to conduct the transportability study.

This report, Volume IV of the PERSHING TRANSPORTABILITY STUDY, presents the results of the vessel stowage static study. Other reports on the PERSHING TRANSPORTABILITY STUDY include Volume I, Calculations and Analysis of Railway Tests; Volume II, CONUS Railways; and Volume III, Foreign Railways.

II. OBJECTIVE

To evaluate the structural integrity of a restraining arrangement for the stowage of Pershing missile containers aboard a vessel and the ability of the containers to withstand restraining loads.

III. CONCLUSIONS

1. The container skids do not have the required structural strength to resist an applied 3g transverse load (load applied to end of skid) when the containers are arranged in a series of four.
2. The container skids do not have the required structural strength to resist a 1g longitudinal load when the containers are arranged in a series of ten.
3. The container can satisfactorily withstand a 3g vertical loading.
4. The tested restraining arrangement for stowage of containers aboard a vessel can satisfactorily withstand vertical, transverse, and longitudinal loads up to the amount of the loads applied in the tests.
5. The two bolts attaching the skid to the container do not have the required shear strength, consequently making it imperative that the skid be abutted flush with the forklift receptacle to provide additional strength.
6. The skids on one end of the containers are transversely reinforced by the container base structure, whereas the skids on the opposite end are not reinforced. The unsupported end does not have the required structural strength to resist loads oriented transversely to the container.

IV. RECOMMENDATIONS

1. To provide the required structural strength to resist restraining loads during shipment, without retrofit to the container, the tested stowage plan and restraining arrangement be modified as follows:
 - a. Two 4-by-6-inch timbers be applied between the unsupported skids to transmit restraining forces applied transversely to the container.
 - b. Hardwood filler blocks be applied between the end of the skids and the forklift receptacles on those containers where the skid is not abutted flush with the receptacle.

2. The unsupported skids be modified to provide strength equal to that of the reinforced skids.
3. Manufacturing tolerances be maintained to insure that the ends of the container skids are abutted flush with the forklift receptacles.
4. The proposed stowage plan and restraining arrangement be followed during actual container movements.
5. When additional criteria and information are obtained, the proposed stowage plan and restraining arrangement be reevaluated to accomplish maximum optimization in the shipping procedures.

V. FIELD EVALUATION

GENERAL

The stowage of Pershing missile containers aboard a vessel has been predicated on the following requirements:

1. The containers would be loaded in the upper tween deck of the vessel.
2. The deck would be of steel structure without restraining devices.
3. A modular (one or more) concept and standard restraining methods would be used in stowing containers. The proposed stowing and restraining arrangements are illustrated in USATEA Drawings 410-65-001 through 410-65-005.

To evaluate the structural integrity of the proposed restraining arrangement and the effects of restraining loads on the containers, static tests were conducted and the results are presented herein.

DESCRIPTION OF EQUIPMENT

The container used in the study was a Research and Development (R&D) XM 476, illustrated in Figure 1. Other Pershing missile system containers have a similar geometry and construction; therefore, the results of the study are equally applicable to them.

INSTRUMENTATION

Vertical Load Application. Vertical loading was applied by simulated known weights.

Longitudinal Load Application. The load, applied by three 30-ton hydraulic jacks, was measured electronically on compression-type load cells and recorded on a visicorder, as illustrated schematically in Figure 2.

Lateral Load Application . The load, applied by two 30-ton hydraulic jacks, was measured electronically on compression-type load cells and recorded on a strain indicator, as illustrated schematically in Figure 3.



Figure 1. Research and Development XM 476 Container.

**COX AND STEVENS 100,000-LB. PRECISION LOAD CELL,
SERIAL NO. 14538, TYPICAL**

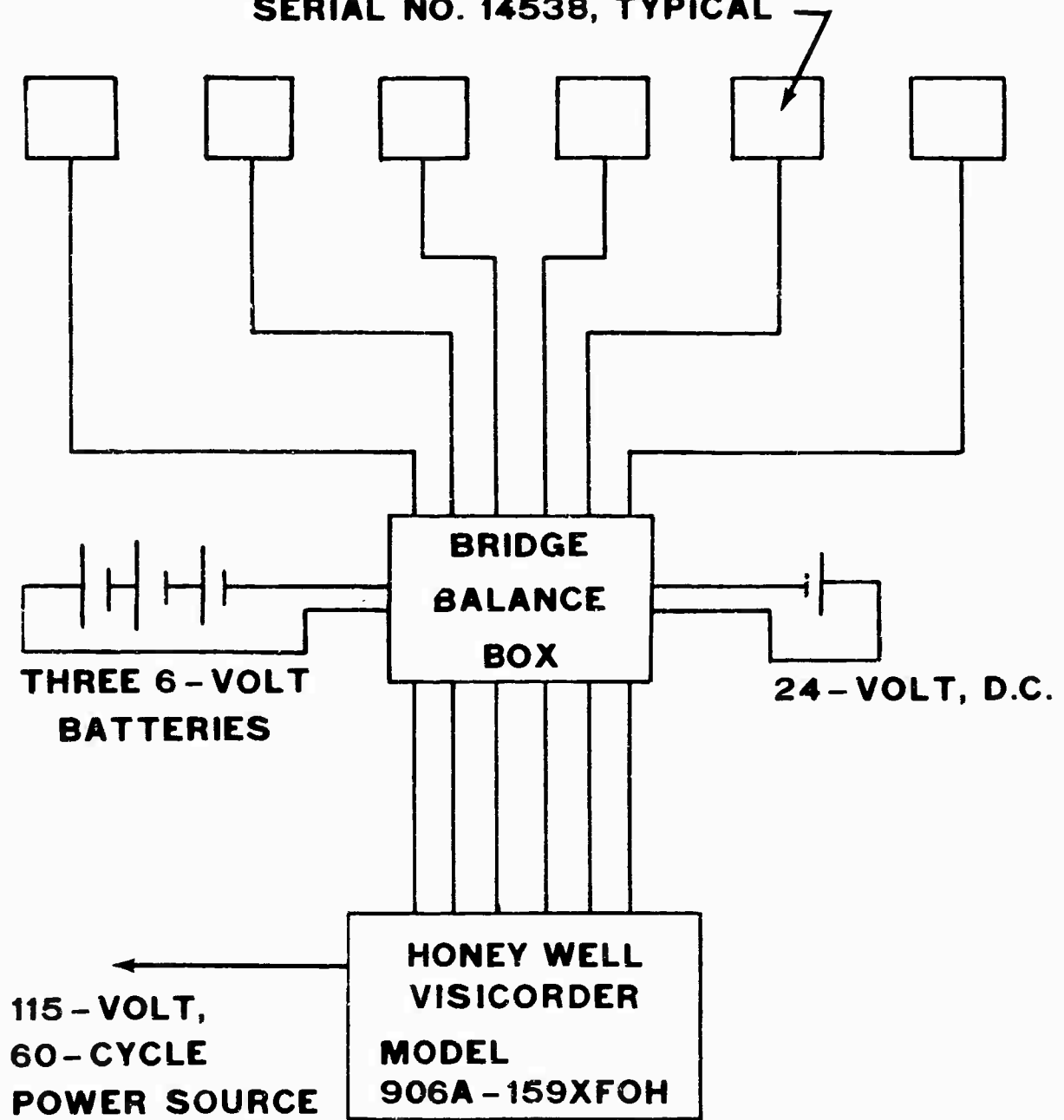

Figure 2. Schematic of Instrumentation.

**BALDWIN 50,000-LB. LOAD CELL,
TYPE SR-4-U-1, TYPICAL**

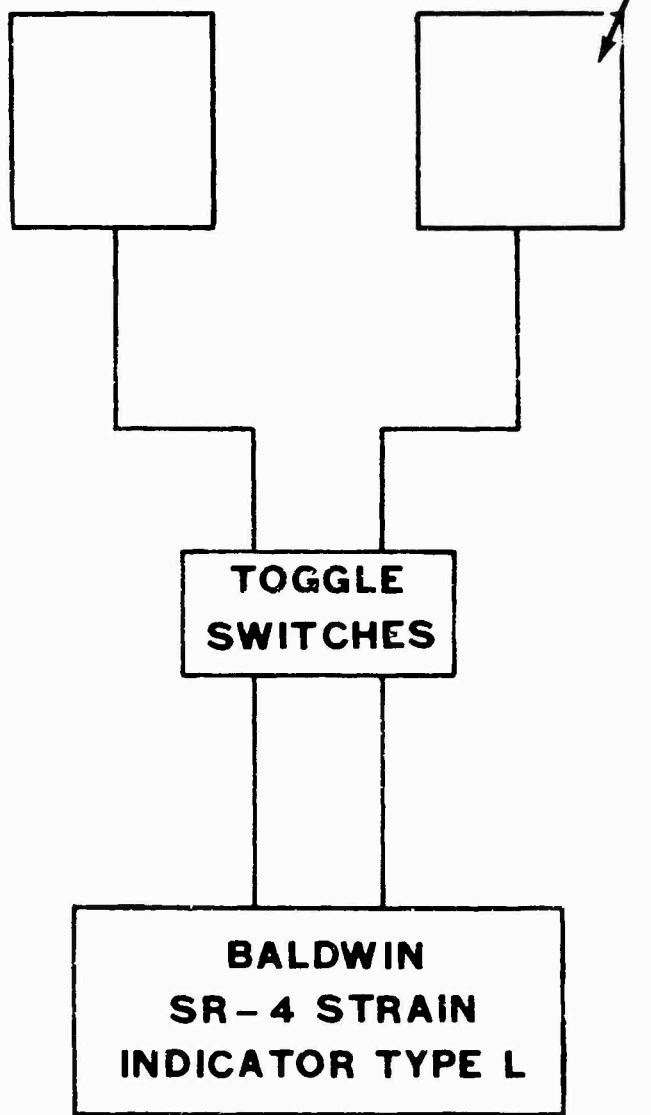

Figure 3. Schematic of Instrumentation.

VI. TRANSPORTATION ENGINEERING ANALYSIS

In analyzing the transportation engineering aspects, static field tests were conducted in which an R&D XM 476 Pershing missile container was placed in a reinforced concrete test pit. Transportability criteria loadings were applied as described in the following paragraphs.

Vertical Loading Procedures and Results

Vertical restraining members and accompanying lateral support members were installed in conformance with the stowage plan and restraining arrangement drawings. Figure 4 illustrates the vertical restraining members. A loading platform was constructed on top of the vertical 4-by-4-inch members, as shown in Figure 5.

The first test loading consisted of four 2,500-pound concrete blocks assembled as a unit load. This load was placed on the platform and removed by a truck crane seven times in a 15-minute period, and then left on the platform for 5 minutes. The total load on the container stacking pads (including weight of timber) in the test was 10,425 pounds.

The second and final loading consisted of seven 2,500-pound concrete blocks assembled as a unit load. This load was placed on the platform and removed by a truck crane six times in a 20-minute period, and then left on the platform for 10 minutes. Figure 6 illustrates the 17,500-pound load positioned on the platform. The total load on the container stacking pads (including the weight of timber) in the test was 17,925 pounds.

The timber restraining arrangement sustained the applied loads, with no apparent damage to the container.

Longitudinal Loading Procedures and Results

Longitudinal restraining members were installed in conformance with the stowage and restraining arrangement drawings. A simulated load equal to 10 containers in series was applied. Figure 7 illustrates the restraining members under test. The first loading was applied at four points along the container and amounted to a total force of 30,000 pounds. Application of load at this point was stopped because of the inward deflection of both the aft container skids. To prevent damage to the unsupported skids and to provide for load transfer in the recommended restraining arrangement, the load was released and two 4-by-6-inch timbers were installed between the unsupported skids.

The final test setup was changed to include three hydraulic jacks and six load cells, as illustrated in Figure 8.

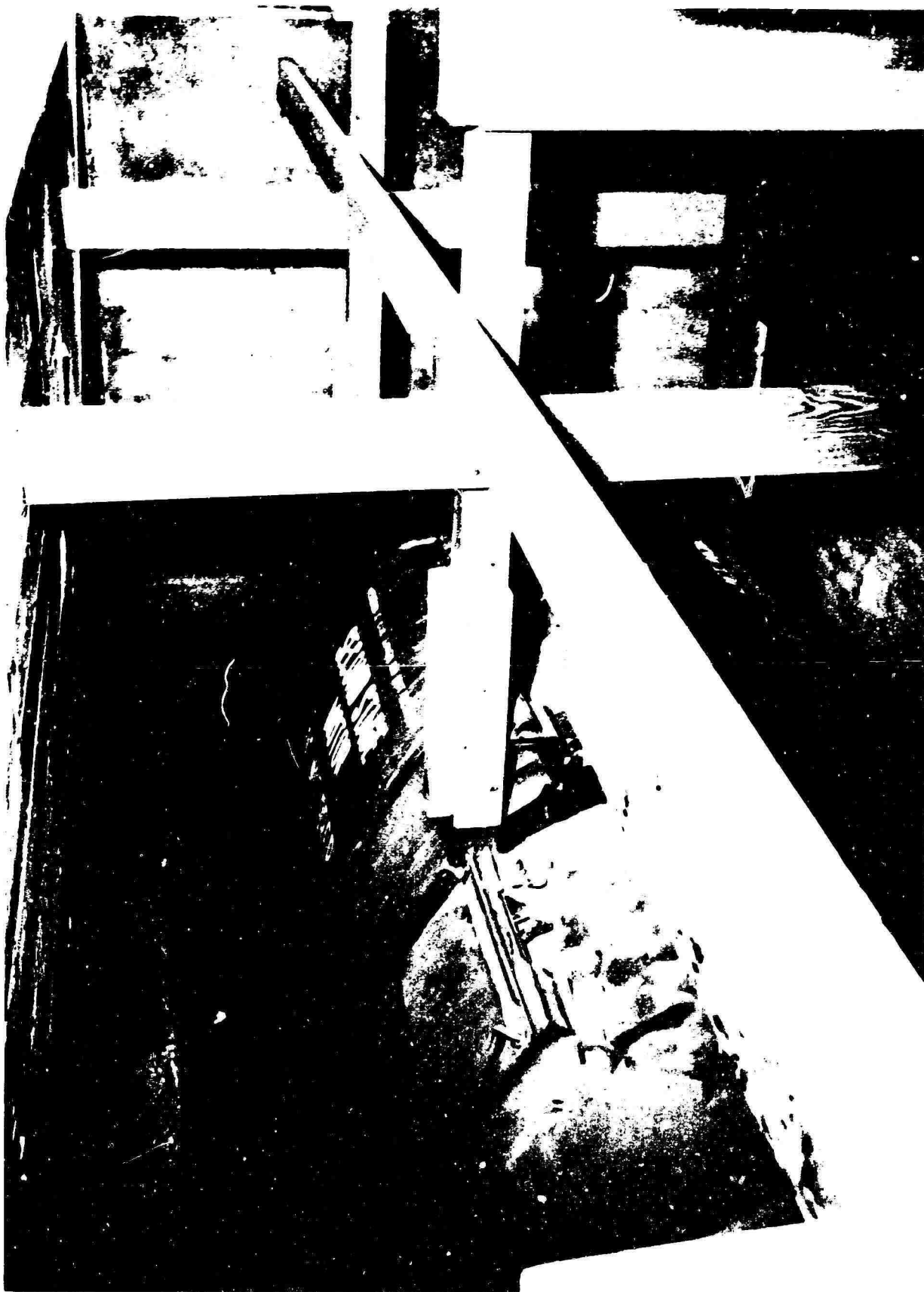

Figure 4. Vertical Restraining Arrangement.

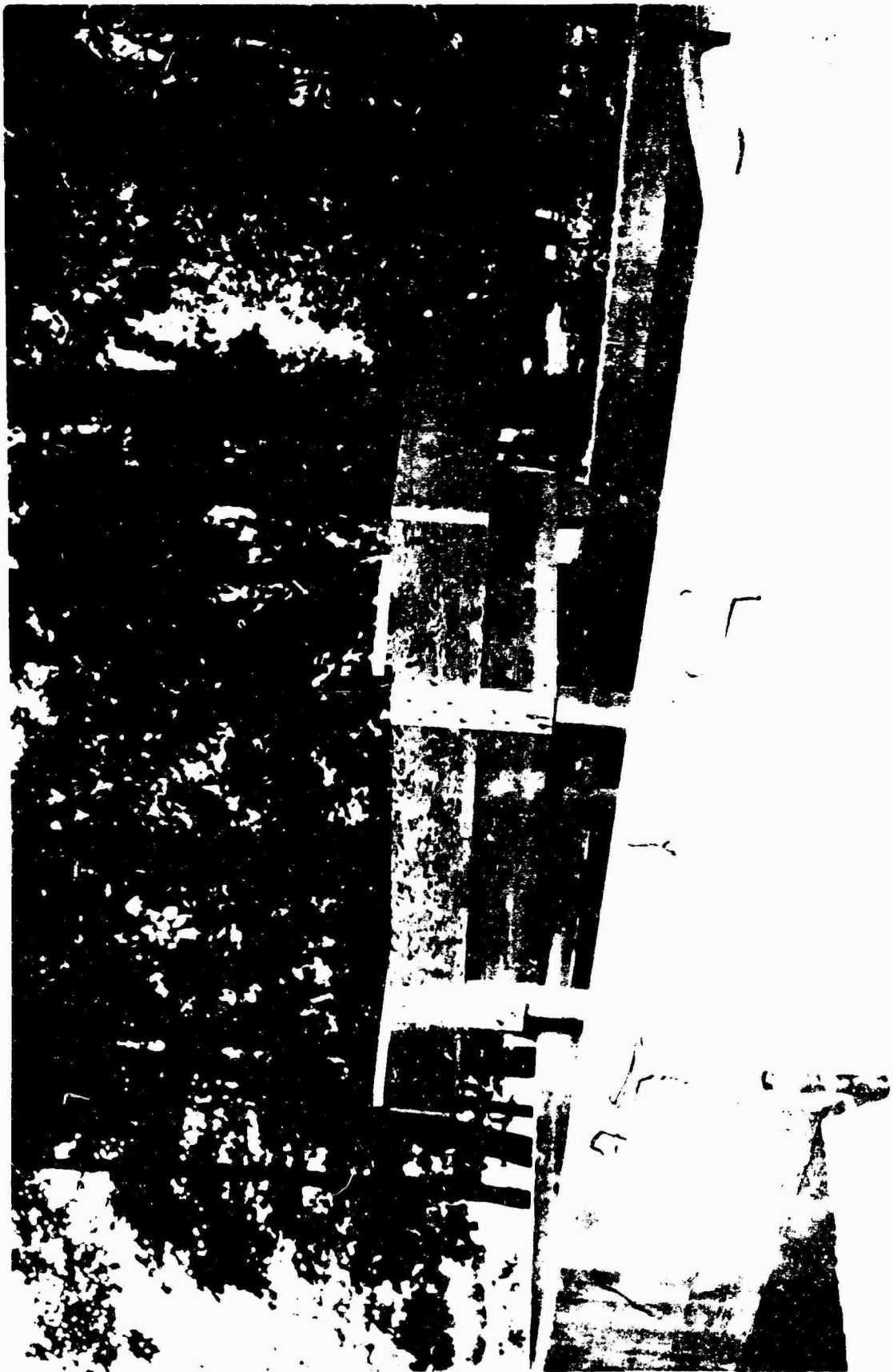

Figure 5. Loading Platform on Top of Vertical Members.



Figure 6. 17,500-Pound Load in Position.



Figure 7. Longitudinal Restraining Members Under Test.



Figure 8. Test Setup for Longitudinal Loading.

The load was applied and maintained as indicated in Table I.

TABLE I
LONGITUDINAL LOADS APPLIED
TO R&D XM 476 CONTAINER

Total Loads (lb)	Duration (min)
60,000 to 66,500	15
66,500 to 56,000	5
56,000 to 65,300	12
65,300 to 74,500	13
74,500 to 66,400	4
66,400 to 70,500	20
70,500 to 72,000	10
72,000 to 72,700	15

The restraining arrangement sustained the applied loads. The unsupported container skids did not have adequate strength to transmit the restraining loads; consequently, it was necessary to apply two 4-by-6-inch timbers between the skids.

Transverse Loading Procedures and Results

Transverse restraining members were installed in conformance with the stowage plan and restraining arrangement drawings, to simulate a loading of four containers in one line. Two 4-by-6-inch cross members between the unsupported skids, and wood filler blocks between the end of the skids and the forklift receptacle were installed. Figure 9 illustrates the restraining members under test. The design loads were applied by two 30-ton hydraulic jacks and measured on two load cells, as illustrated in Figure 10. The load was applied and maintained as shown in Table II.

TABLE II
TRANSVERSE LOADS APPLIED
TO R&D XM 476 CONTAINER

Total Loads (lb)	Duration (min)
50,000	10
60,000	10
80,000	10
69,000	10
56,000 to 101,000	20



Figure 9. Transverse Restraining Members Under Test.

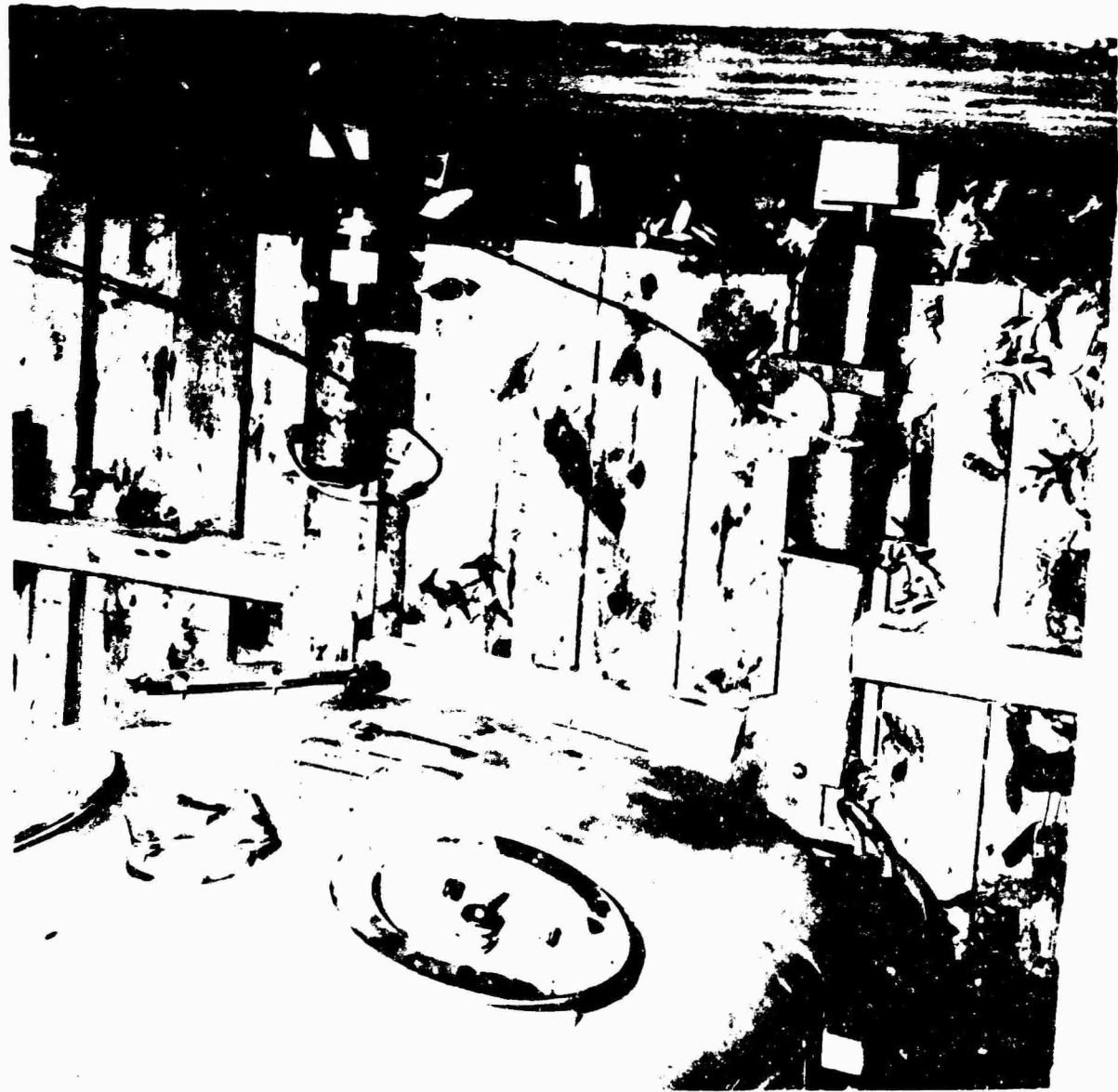

Figure 10. Test Setup for Transverse Loading.

The first indication of failure of the container skids occurred when the 80,000-pound load was applied. This initial failure was detected by a $\frac{1}{4}$ -inch movement of the right unsupported skid, which caused initial deformation of the forklift receptacle. Under the 101,000-pound load, the two bolts attaching the right unsupported skid to the container sheared off. One bolt on the left unsupported skid sheared off, and the two channel sections (forming the forklift receptacles) were bent as illustrated in Figure 11. The transverse restraining arrangement sustained the applied loads.

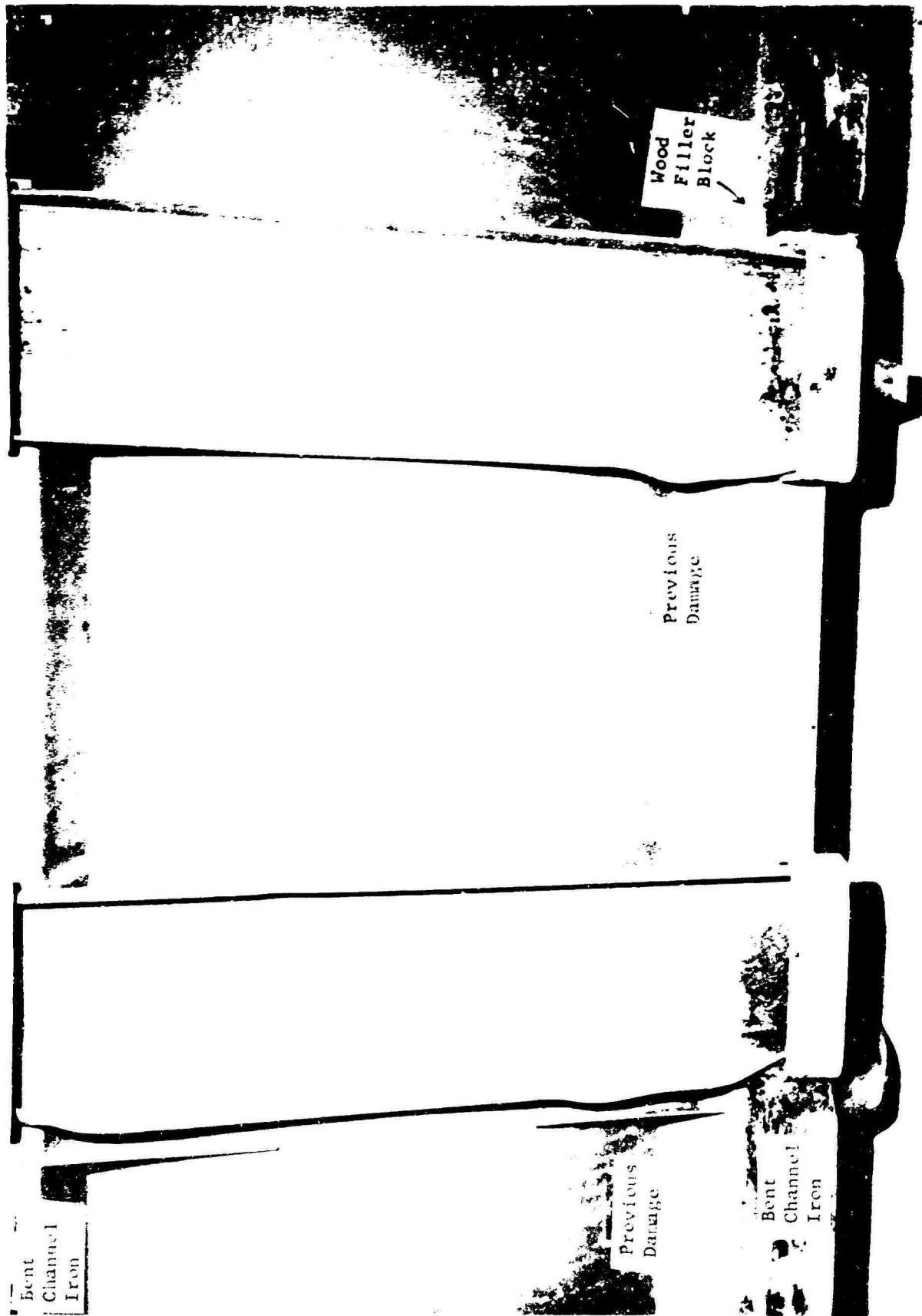

Figure 11. Channel Sections (Bottom View).

VII. TRANSPORTATION SYSTEM ANALYSIS

Design loadings for the restraining arrangement are based on accelerations of 3g vertically and transversely and 1g longitudinally. The loadings resulting from these accelerations are considered to be ultimate loads. The maximum expected loads are one-half the ultimate loads, as set forth in TB 55-100 (Reference 3).

Since the XM 475 and XM 476 containers are identical in configuration, the design of their restraining systems is identical. Induced loads are based on the XM 475, which is the heavier of the two. The same procedure was applied in the design of the restraining system for the XM 474; however, since the XM 474 is much smaller and lighter in weight, its weight was used in computing the design loads for separate stowage.

The ultimate forces for the loading condition producing the maximum force on the XM 475 container are as follows:

Vertical, upward (1 container)

$$(3 \times 9,110 \text{ lb}) - 9,110 \text{ lb} = \underline{18,220 \text{ lb}}$$

Transverse (4 containers in line)

$$3(4 \times 9,110 \text{ lb}) - 0.2*(4 \times 9,110 \text{ lb}) = \underline{102,032 \text{ lb}}$$

Longitudinal (10 containers in series)

$$1(10 \times 9,110 \text{ lb}) - 0.2*(10 \times 9,110 \text{ lb}) = \underline{72,880 \text{ lb}}$$

*Minimum coefficient of friction, wood on steel, dry.

The test demonstrated that the restraining arrangement will sustain the ultimate design loads, consequently providing a minimum margin of safety of 97 percent as regards the expected maximum loads as set forth in TB 55-100.

The XM 476 container sustained the ultimate vertical load without any apparent damage; however, such was not the case under the longitudinal and transverse loads.

When subjected to the longitudinal loading at a load of 30,000 pounds, the unsupported skids were deflected inward approximately one-quarter inch. It was apparent that the skids would fail unless provisions were made for load transfer. Accordingly, two 4-by-6-inch timbers were installed between the unsupported skids. This procedure was effective, and the container sustained the ultimate design load.

Under the transverse loading, failure of the skid bolts and bending of the channel sections (which form the forklift receptacles) started at a load

of 80,000 pounds and complete failure occurred at 101,000 pounds. Since the maximum expected transverse load is 47,400 pounds, the minimum margin of safety as regards the maximum expected loads for the container skids is:

$$\left(\frac{80,000}{47,400} - 1 \right) 100 = 69\%.$$

VIII. REFERENCES

1. Letter, LOG/TENO-TR, dated 29 September 1965, subject: Pershing Missile System, with 1st and 2d indorsements.
2. Program, Transportability Study on Movement Worldwide of the Pershing Missile System, dated 14 September 1965.
3. TB 55-100, Transportability Criteria - Shock and Vibration, Department of the Army, Washington, D.C., 17 April 1964.
4. Engineering Report, USATEA Report 66-11, PERSHING TRANSPORTABILITY STUDY, Calculations and Analysis of Railway Tests, Vol. I, U.S. Army Transportation Engineering Agency, Fort Eustis, Virginia, July 1966.
5. Engineering Report, USATEA Report 66-11, PERSHING TRANSPORTABILITY STUDY, CONUS Railways, Vol. II, U.S. Army Transportation Engineering Agency, Fort Eustis, Virginia, July 1966.
6. Engineering Report, USATEA Report 66-11, PERSHING TRANSPORTABILITY STUDY, Foreign Railways, Vol. III, U.S. Army Transportation Engineering Agency, Fort Eustis, Virginia, July 1966.

UNCLASSIFIED

Security Classification

DOCUMENT CONTROL DATA - R&D		
<i>(Security classification of title, body of abstract and indexing annotation must be entered when the overall report is classified)</i>		
1 ORIGINATING ACTIVITY (Corporate author) U. S. ARMY TRANSPORTATION ENGINEERING AGENCY Fort Eustis, Virginia	2a REPORT SECURITY CLASSIFICATION Unclassified	2b GROUP
3 REPORT TITLE PERSHING TRANSPORTABILITY STUDY, Vessel Stowage, Vol. IV of IV.		
4 DESCRIPTIVE NOTES (Type of report and inclusive dates)		
5 AUTHOR(S) (Last name, first name, initial) Grier, John H.		
6 REPORT DATE July 1966	7a TOTAL NO OF PAGES 23	7b NO OF REFS 6
8a CONTRACT OR GRANT NO.	9a ORIGINATOR'S REPORT NUMBER(S)	
b. PROJECT NO		
c	9b OTHER REPORT NO(S) (Any other numbers that may be assigned this report)	
d		
10 AVAILABILITY/LIMITATION NOTICES Distribution of this document is unlimited.		
11 SUPPLEMENTARY NOTES	12 SPONSORING MILITARY ACTIVITY	
13 ABSTRACT <p>A vessel stowage static study (a phase of the "Transportability Study on Movement Worldwide of the Pershing Missile System") was conducted on a Pershing missile system second stage motor container, XM 476. The purpose of the study was to evaluate the structural integrity of a proposed procedure for the stowage of an XM 476 and similar containers aboard a vessel subjected to adverse ocean environments, that is, State of Sea, Bowditch Scale 5-7. Dynamic loadings likely to accrue from such an environment were empirically reduced to static criteria and measurement. Other portions of the overall study will obtain actual measurements of the dynamic loading. The applied static loading conditions were (1) 3g vertical, (2) 3g transverse, and (3) 1g longitudinal.</p> <p>Results of the study showed that the container skids do not have the required structural strength to resist the applied static loading conditions. The proposed stowage plan and restraining procedure proved to be satisfactory in withstanding the applied static loads.</p>		

DD FORM 1473
1 JAN 64

UNCLASSIFIED

Security Classification

UNCLASSIFIED

Security Classification

14 KEY WORDS	LINK A		LINK B		LINK C	
	ROLE	WT	ROLE	WT	ROLE	WT
<p>Shock and Vibration</p> <p>Vessel Stowage</p>						

INSTRUCTIONS

1. ORIGINAL ACTIVITY: Enter the name and address of the contractor, subcontractor, grantee, Department of Defense activity or other organization (*corporate autho.*) issuing the report.

2a. REPORT SECURITY CLASSIFICATION: Enter the overall security classification of the report. Indicate whether "Restricted Data" is included. Marking is to be in accordance with appropriate security regulations.

2b. GROUP: Automatic downgrading is specified in DoD Directive 5200.10 and Armed Forces Industrial Manual. Enter the group number. Also, when applicable, show that optional markings have been used for Group 3 and Group 4 as authorized.

3. REPORT TITLE: Enter the complete report title in all capital letters. Titles in all cases should be unclassified. If a meaningful title cannot be selected without classification, show title classification in all capitals in parenthesis immediately following the title.

4. DESCRIPTIVE NOTES: If appropriate, enter the type of report, e.g., interim, progress, summary, annual, or final. Give the inclusive dates when a specific reporting period is covered.

5. AUTHOR(S): Enter the name(s) of author(s) as shown on or in the report. Enter last name, first name, middle initial. If military, show rank and branch of service. The name of the principal author is an absolute minimum requirement.

6. REPORT DATE: Enter the date of the report as day, month, year, or month, year. If more than one date appears on the report, use date of publication.

7a. TOTAL NUMBER OF PAGES: The total page count should follow normal pagination procedures, i.e., enter the number of pages containing information.

7b. NUMBER OF REFERENCES: Enter the total number of references cited in the report.

8a. CONTRACT OR GRANT NUMBER: If appropriate, enter the applicable number of the contract or grant under which the report was written.

8b, 8c, & 8d. PROJECT NUMBER: Enter the appropriate military department identification, such as project number, subproject number, system numbers, task number, etc.

9a. ORIGINATOR'S REPORT NUMBER(S): Enter the official report number by which the document will be identified and controlled by the originating activity. This number must be unique to this report.

9b. OTHER REPORT NUMBER(S): If the report has been assigned any other report numbers (*either by the originator or by the sponsor*), also enter this number(s).

10. AVAILABILITY/LIMITATION NOTICES: Enter any limitations on further dissemination of the report, other than those imposed by security classification, using standard statements such as:

(1) "Qualified requesters may obtain copies of this report from DDC."

(2) "Foreign announcement and dissemination of this report by DDC is not authorized."

(3) "U. S. Government agencies may obtain copies of this report directly from DDC. Other qualified DDC users shall request through _____."

(4) "U. S. military agencies may obtain copies of this report directly from DDC. Other qualified users shall request through _____."

(5) "All distribution of this report is controlled. Qualified DDC users shall request through _____."

If the report has been furnished to the Office of Technical Services, Department of Commerce, for sale to the public, indicate this fact and enter the price, if known.

11. SUPPLEMENTARY NOTES: Use for additional explanatory notes.

12. SPONSORING MILITARY ACTIVITY: Enter the name of the departmental project office or laboratory sponsoring (*paying for*) the research and development. Include address.

13. ABSTRACT: Enter an abstract giving a brief and factual summary of the document indicative of the report, even though it may also appear elsewhere in the body of the technical report. If additional space is required, a continuation sheet shall be attached.

It is highly desirable that the abstract of classified reports be unclassified. Each paragraph of the abstract shall end with an indication of the military security classification of the information in the paragraph, represented as (TS), (S), (C), or (U).

There is no limitation on the length of the abstract. However, the suggested length is from 150 to 225 words.

14. KEY WORDS: Key words are technically meaningful terms or short phrases that characterize a report and may be used as index entries for cataloging the report. Key words must be selected so that no security classification is required. Identifiers, such as equipment model designation, trade name, military project code name, geographic location, may be used as key words but will be followed by an indication of technical context. The assignment of links, rules, and weights is optional.

UNCLASSIFIED

Security Classification

4464-66