

AD 642240

ARL 66-0112
JUNE 1966



Aerospace Research Laboratories

AN INVESTIGATION OF THE BEHAVIOR OF A DETONATION WAVE IN A FLOWING COMBUSTIBLE MIXTURE

WILLIAM W. McKENNA
AIR FORCE INSTITUTE of TECHNOLOGY (AU)
WRIGHT-PATTERSON AIR FORCE BASE, OHIO

PROJECT NO. 7065

CLEARINGHOUSE FOR FEDERAL SCIENTIFIC AND TECHNICAL INFORMATION			
Hardcopy	Microfiche		
\$3.00	\$.65	133	PP 72
/ ARCHIVE COPY			

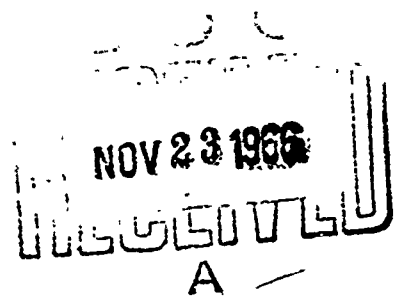

Distribution of this document is unlimited

OFFICE OF AEROSPACE RESEARCH
United States Air Force



NOTICES

When Government drawings, specifications, or other data are used for any purpose other than in connection with a definitely related Government procurement operation, the United States Government thereby incurs no responsibility nor any obligation whatsoever; and the fact that the Government may have formulated, furnished, or in any way supplied the said drawings, specifications, or other data, is not to be regarded by implication or otherwise as in any manner licensing the holder or any other person or corporation, or conveying any rights or permission to manufacture, use, or sell any patented invention that may in any way be related thereto.

Qualified requesters may obtain copies of this report from the Defense Documentation Center, (DDC), Cameron Station, Alexandria, Virginia. All others should apply to the Clearinghouse for Scientific and Technical Information.

SECTION FOR	
DATE	WHITE SECTION
NO.	BUFF SECTION
ANNOUNCED	
NOTICE	
DISTRIBUTION/AVAILABILITY	
DIST.	RETAIL

Copies of ARL Technical Documentary Reports should not be returned to Aerospace Research Laboratories unless return is required by security considerations, contractual obligations or notices on a specified document.

ARL 66-0112

**AN INVESTIGATION OF THE BEHAVIOR OF A
DETONATION WAVE IN A FLOWING COMBUSTIBLE MIXTURE**

WILLIAM W. McKENNA
AIR FORCE INSTITUTE of TECHNOLOGY (AU)
WRIGHT-PATTERSON AIR FORCE BASE, OHIO

Submitted to the Faculty of the Graduate School of
The Ohio State University
in partial fulfillment of the requirements
for the degree of
DOCTOR OF PHILOSOPHY

JUNE 1966

PROJECT 7065

Distribution of this
document is unlimited

**AEROSPACE RESEARCH LABORATORIES
OFFICE OF AEROSPACE RESEARCH
UNITED STATES AIR FORCE
WRIGHT-PATTERSON AIR FORCE BASE, OHIO**

FOREWORD

This technical report was prepared by Lt. Col. William W. McKenna of the Department of Mechanical Engineering of the Air Force Institute of Technology and was presented to the Department of Aeronautical and Astronautical Engineering of the Ohio State University in partial fulfillment of the requirements for the degree of Doctor of Philosophy. The research was partially sponsored by the Aerospace Research Laboratories, Wright-Patterson Air Force Base, Ohio with Dr. R. G. Dunn as the Coordinator.

This report is the only and final report of this investigation and covers the period from August 1964 to June 1966.

ABSTRACT

The study of detonation waves in a flowing combustible mixture of gas could lead to a better understanding of combustion instability in rocket motors and to possible application to supersonic combustion. Apparatus was designed to measure the relative wave velocity and to photograph the wave profile as a fully developed detonation wave propagated against a flow of stoichiometric mixture of hydrogen-oxygen gases. The Mach number of the flowing gas was varied from 0.14 to 4. The subsonic flow results indicated that the absolute detonation wave velocity relative to the gas was independent of the speed of the flowing gas. But, the supersonic flow results indicated a strong wave which was contributed to the particular pressure profile in the tube during the supersonic flows. The schlieren photographs of the wave indicated propagation into the boundary layer and a convex curvature of the complete wave front was observed in the Mach 4 flow. Velocity measurements indicated that the detonation wave was steady but it is believed that retonation waves were observed in some experiments.

ACKNOWLEDGMENT

I wish to express my sincere gratitude to my adviser, Professor Rudolph Edse for his continued encouragement, patience, suggestions, and technical guidance throughout my entire Ph.D. program.

I am grateful to the United States Air Force for the opportunity to pursue this research. In particular I am indebted to the Air Force Institute of Technology (AFIT) and the Aerospace Research Laboratories of the United States Air Force who provided the facilities and instrumentation.

I gratefully acknowledge my indebtedness to Dr. M. Kabrisky of the Electrical Engineering Department of AFIT for his assistance with the electronics that were involved in my research.

I hereby acknowledge my appreciation to Major G. P. Bowman of the Mechanical Engineering Department of AFIT for the use of the computer program that he prepared.

I gratefully acknowledge my appreciation to Dr. U. Grimm and Dr. G. Mueller of the Aerospace Research Laboratories for their technical advice on many problems encountered in the research.

I want to thank Mr. J. W. Parks, laboratory technician of the Mechanical Engineering Department of AFIT, for his assistance throughout the experimental phase of the research.

In addition, I want to acknowledge the excellent work that was done by the personnel of the AFIT School Shops in the construction of

the apparatus that was used in the research. In particular I want to thank Mr. M. Wolfe and Mr. C. H. Shortt.

Also, I want to acknowledge the assistance provided to me by many other people from many organizations at Wright Field. Many times the research could not have continued had not the necessary supplies and equipment been provided.

Finally, I wish to thank my wife and children for the sacrifices they made in order for me to pursue this research.

VITA

February 28, 1923	Born--Baggaley, Pennsylvania
1943	B.S., Pennsylvania State College State College, Pennsylvania
1943-1966	Officer, United States Air Force
1953	M.S., Massachusetts Institute of Technology Cambridge, Massachusetts
1961-1962	Graduate Student, Department of Aeronautical and Astronautical Engineering The Ohio State University Columbus, Ohio
1962	E.A.A., Massachusetts Institute of Technology Cambridge, Massachusetts
1962-1966	Part-Time Graduate Student, Department of Aeronautical and Astronautical Engineering The Ohio State University Graduate Center Wright Field, Dayton, Ohio
1962-1966	Associate Professor of Mechanical Engineering Air Force Institute of Technology Wright-Patterson Air Force Base, Ohio

PUBLICATIONS

"The Effect of Drift of the Inertial Reference on the Performance of an Inertial Navigation System," Instrumentation Laboratory Report T-43, Massachusetts Institute of Technology, August 1953

FIELDS OF STUDY

Major Field: Aeronautical and Astronautical Engineering

Studies in Inertial Guidance. Professors Charles S. Draper,
Wintson R. Markey and Walter Wrigley

Studies in Propulsion. Professor Rudolph Edse

CONTENTS

	PAGE
ACKNOWLEDGMENTS	iv
VITA	vi
TABLES	ix
ILLUSTRATIONS	x
NOMENCLATURE	xiii
CHAPTER	
I. INTRODUCTION	1
Background	1
Purpose of Investigation	2
Scope of Investigation	3
Survey of the Literature	4
II. THEORETICAL CONSIDERATIONS	7
Theoretical Detonation Parameters	7
Structure of the Detonation Wave	9
III. EQUIPMENT FOR THE RESEARCH	13
Apparatus	13
Gas Supply and Control System	19
Instrumentation	21
Optical System	26
IV. EXPERIMENTAL TECHNIQUES AND PROCEDURES	30
Initiation Tube Experiments	30
Calibration of the Flowing-Gas Detonation Tube	32
Operation of the Detonation System	34
V. RESULTS	37
Theoretical Investigations	37
Experimental Investigations	38

CONTENTS (contd.)

CHAPTER	PAGE
VI. DISCUSSION OF RESULTS	43
General	43
Subsonic Flow Results	44
Supersonic Flow Results	47
Photographic Results of Detonation	54
VII. CONCLUSIONS	59
APPENDIXES	
I. THEORETICAL CALCULATIONS	62
II. EXPERIMENTAL RESULTS (DATA TABLES)	66
III. DATA REDUCTION CALCULATIONS	71
IV. OPERATION OF DETONATION SYSTEM	76
REFERENCES	81

TABLES

Table		Page
1	Theoretical Detonation Wave Parameters for Supersonic Flow of Mach 1 to 4	55
2	Subsonic Test Data for a Detonation Wave Propagating in a Flowing Stoichiometric Mixture of Hydrogen - Oxygen	67
3	Relative Velocities of the Detonation Wave Between Ionization Probes for Subsonic Flows	68
4	Supersonic Test Data for a Detonation Wave Propagating in a Flowing Stoichiometric Mixture of Hydrogen - Oxygen	69
5	Relative Velocities of the Detonation Wave Between Ionization Probes for Supersonic Flows	70

ILLUSTRATIONS

Figure		Page
1	Schematic Diagram of the Detonation System	84
2	Overall Picture of the Detonation System	85
3	The Initiation Detonation Tube and Mixing Chamber . . .	86
4	The Flowing-Gas Detonation Tube	87
5	Transition Section and Diaphragm Section in the Exhaust Duct	88
6	The Modified Ignition Source	89
7	The Gas Supply and Control System for the Detonation System	90
8	The Control Room and Instrumentation	91
9	Schematic Diagram of the Instrumentation System	92
10	The Ionization Probe and Boss	93
11	Electrical Circuit for the Ionization Probes	94
12	A Typical Oscilloscope Photograph	95
13	The Optical System Installed in the Flowing-Gas Detonation Tube	96
14	The Viewing Section of the Optical System	97
15	A Schematic Diagram of the Spark Light and Synchronization System of the Optical System	98
16	A Schematic Diagram of the Modified Toepler System . .	99
17	The Theoretical Variations of Final Temperature with Initial Temperature at a Constant Initial Pressure of a Detonation Wave for a Stoichiometric Mixture of Hydrogen - Oxygen	100

ILLUSTRATIONS (contd.)

Figure		Page
18	The Theoretical Variations of Final Pressure with Initial Temperature at a Constant Initial Pressure of a Detonation Wave for a Stoichiometric Mixture of Hydrogen - Oxygen	101
19	The Theoretical Variations of the Absolute Chapman-Jouguet Detonation Wave Velocity with Initial Temperature at Constant Initial Pressure for a Stoichiometric Mixture of Hydrogen - Oxygen	102
20	Theoretical Variations of Pressures and Temperatures Before and Behind the Detonation Wave in Subsonic Flow	103
21	Theoretical Variations of Pressures and Temperatures Before and Behind the Detonation Wave in Supersonic Flow	104
22	The Theoretical Variations of the Velocities in the Detonation Tube for Subsonic Flows	105
23	The Theoretical Variations of the Velocities in the Detonation Tube for Supersonic Flows	106
24	The Comparison of the Experimental and Theoretical Relative Velocities of a Detonation Wave Against a Subsonic Flow	107
25	The Comparison of the Experimental and Theoretical Relative Velocities of a Detonation Wave against a Supersonic Flow	108
26	The Chapman-Jouguet Detonation Wave Velocity for Various Mixtures of Hydrogen - Oxygen at 1 ATM and 298°K	109
27	Schlieren Photograph of a Detonation Wave Propagating Against a Subsonic Flow of 576 feet/sec	110
28	Schlieren Photograph of a Detonation Wave Propagating Against a Subsonic Flow of 683 feet/sec	110
29	Schlieren Photograph of a Detonation Wave Propagating Against a Subsonic Flow of 845 feet/sec	111

ILLUSTRATIONS (contd.)

Figure		Page
30	Schlieren Photograph of a Detonation Wave Propagating Against a Subsonic Flow of 970 feet/sec	111
31	Schlieren Photograph of a Detonation Wave Propagating Against a Supersonic Flow of Mach 2.79	112
32	Schlieren Photograph of a Detonation Wave Propagating Against a Supersonic Flow of Mach 3.85	112
33	Schlieren Photograph of a Detonation Wave and a Retonation Wave in a Subsonic Flow	113
34	Schlieren Photograph of a Detonation Wave and a Retonation Wave in a Supersonic Flow	113
35	The Theoretical Variation of the Pressure Ratio of a Detonation Wave Versus Mach Number for Flows Against a Supersonic Stream	114
36	The Theoretical Variation of the Temperature Ratio of a Detonation Wave Versus Mach Number for Flows Against a Supersonic Stream	115

NOMENCLATURE

Symbol	Definition
$^{\circ}\text{K}$	Absolute temperature in degrees Kelvin.
\dot{m}_t	Total mass flow rate.
m_1	Molecular weight of the gas into which the detonation wave propagated.
m_b	Molecular weight of the gas behind the detonation wave.
$M_{u,1}$	Average Mach number of the flowing combustible mixture of hydrogen - oxygen gas (unburned gas).
$M_{D,1}$	Mach number of the theoretical absolute Chapman-Jouguet steady velocity of the detonation wave based on the temperature of the media into which the wave propagated.
$M_{D,2}$	Mach number of the gas in the detonation wave immediately behind the front. It was assumed to be a normal shock relation to $M_{D,1}$.
P_1	Initial static pressure into which the detonation wave propagated.
P_b	Static pressure of the burned gas behind the detonation wave.
P_c	Chamber pressure in the stagnation chamber.
q	Heat added to the detonation wave.
r	Mixture ratio.
R	Universal gas constant.
T_1	Initial static temperature into which the detonation wave propagated.
T_b	Static temperature of the burned gas behind the detonation wave.

NOMENCLATURE (contd.)

Symbol	Definition
u_1	Average velocity of the flowing combustible mixture of hydrogen - oxygen gas (unburned gas).
$W_{D,1}(\text{ABS-TH})$	Theoretical absolute Chapman-Jouguet steady velocity of the detonation wave. This velocity was the speed of the front of the detonation wave with respect to the media into which the wave propagated.
$W_{D,1}(\text{ABS-EXP})$	Experimental absolute Chapman-Jouguet steady velocity of the detonation wave. This velocity was the speed of the detonation wave with respect to the media into which the wave propagated.
$W_{D,1}(\text{REL-TH})$	Theoretical relative velocity of the detonation wave with respect to the tube.
$W_{D,1}(\text{REL-EXP})$	Experimental relative velocity of the detonation wave with respect to the tube.
ρ_1	Density of the gas into which the detonation wave propagated.
ρ_b	Density of the burned gas behind the detonation wave.

CHAPTER I

INTRODUCTION

Background

The study of the propagation of detonation waves into a combustible gas has been a subject of research for almost a century. Primarily the investigations have been conducted on fully developed waves propagating into gas at rest. Initially it appeared that the main interest was to confirm experimentally the theoretical propagation velocity as predicted by the Chapman-Jouguet theory and to discuss models of the phenomena to explain any differences. A comprehensive summary and list of references of this research were reported by Wolfson (20). In the past two decades, further investigations have been conducted with the main concern into the development of the wave, its stability and structure. The current interest has been brought about because of the possible relationship of detonation waves to many combustion phenomena. Thus in the past two decades considerable research has been performed in an attempt to obtain a more thorough understanding of detonation waves. A survey of this research was reported by Oppenheim (17) and Bollinger (2).

Recent theoretical and experimental studies have indicated that detonation-type phenomena play a role in the undesirable combustion instability in rocket motors. Also, it may be possible that some

type of a detonation process could be employed in supersonic combustion. Furthermore, the detonation wave affords a medium in which further studies can be made of the chemical kinetics of combustion. Thus, there are abundant reasons and evidence why expanded research in the area of detonation waves is of interest to the researcher today. Also, the researchers today include not only those interested in the chemistry of detonation but also aeronautical and astronautical engineers who are concerned with propulsion systems.

As a result of this interest, a research program on detonation waves was initiated in August 1964 by the Mechanical Engineering Department of the Air Force Institute of Technology (AFIT) at Wright Field, Ohio. This effort was also of interest to the personnel of the Air Force Aerospace Research Laboratories and Aerospace Propulsion Laboratory at Wright Field which resulted in both encouragement and support of the project. The effort was conducted by the author of this dissertation and several graduate students at AFIT who worked under his supervision.

Purpose of Investigation

After a thorough review of the studies of other investigators in the area of detonation and as a result of focusing attention to its application to combustion, the present area of research was initiated. In the present investigation the behavior of a detonation wave in a flowing combustible mixture was studied. The review of the literature revealed that primarily all the research previously had been conducted

on detonation waves propagating into a static mixture of combustible gas. One group had attempted to study the wave in a flowing gas, but with little success (10). This area of study was selected because it was recognized that some possible applications of detonation-type phenomena would be associated with the wave propagating into a flowing mixture instead of a static mixture. This study could be of interest in further understanding the problems of combustion instability where experimental evidence has brought out characteristics of detonation in the combustion chamber of rocket motors in which a combustible gas is flowing. Also, a much more important reason for this study was the application of detonation to supersonic combustion. Here the detonation wave could be the combustion zone and would be in a supersonic or a hypersonic stream. It could be present as the result of shock induced combustion or if one stretches one's imagination, it could be a standing detonation wave where its propagation velocity matches the incoming flow velocity. These ideas formed the nucleus for this study.

Scope of Investigation

The objective of this investigation was to study the behavior of a detonation wave in a flowing combustible mixture. The Mach number of the flowing gas was varied from 0.14 to 4. The theoretical detonation parameters were calculated for the various initial conditions corresponding to those encountered in the flowing gas. The preliminary phase of this investigation was to design and construct

the apparatus, to provide the gas supply and control system and the instrumentation. The experimental phase involved the measurement of the velocity of the detonation wave as it propagated upstream in subsonic and supersonic flows, and the photographing of the profile of the detonation wave as it propagated into the moving gas mixture. Finally, an analysis was made of the experimental data to determine how they compared with the expected results that were predicted.

A brief description of the experimental procedure for this investigation follows: The gas was selected as a stoichiometric mixture of gaseous hydrogen and oxygen. The gases were mixed prior to entering the flowing-gas detonation tube (FDT) or convergent-divergent nozzle in the case of supersonic flows. The detonation wave was initiated in an initiation detonation tube (IDT) downstream of the FDT. The two tubes were separated by a diaphragm. After initiation, the detonation wave propagated upstream, ruptured the diaphragm, and proceeded into the oncoming flow of combustible gas. Then, measurements of the velocity and photographs of the wave were made.

Survey of the Literature

The survey of the literature revealed no other efforts similar to this study except a meager attempt by Hunt (10) to study the influences of a flow field on a detonation wave. Instrumentation problems and basic design limitations of the apparatus prevented Hunt from achieving any significant results. But Gross (8) and Nicholls (15) reported

results that were related to this study in that combustion occurred in a supersonic stream. Both researchers referred to their results as studies of standing detonation waves. In both studies the standing detonation wave occurred as a result of combustion immediately downstream of a shock that existed because of gas dynamic flow conditions. Thus the phenomenon was a result of shock-induced combustion. When speaking of a standing detonation wave, the author of this study thinks of it as a phenomenon in which the propagation velocity of the detonation wave exactly matches the flow velocity of an oncoming mixture of combustible gases; thus the detonation wave is stationary with respect to a set of laboratory coordinates. Gross studied the combustion of a premixed Mach 3 stream of hydrogen and air that was brought about by a normal shock in a supersonic wind tunnel. It is significant to note that Gross reported he had observed that the combustion zone had characteristics of a strong detonation wave. Nicholls succeeded in burning a preheated mixture of hydrogen and air when it flowed through the Mach reflected shock existing in open space downstream of an underexpanded nozzle. The unburned gases were supersonic, but it is not clear whether the combustion wave was a detonation wave. Also, of relation and importance to this study is the recent report of the progress in Russia by Shchelkin and Troshin (19) in regard to the behavior of detonation waves. They reported that all detonation waves are pulsating and cause irregularities which bring about conditions other than those predicted by the Chapman-Jouguet (C-J) theory. Thus as research continues in

detonation, it appears that the Chapman-Jouguet theory and the Zeldovich, von Neuman and Doring (ZND) model do not explain completely the behavior of detonation under all conditions that are of interest to the researcher today.

CHAPTER II

THEORETICAL CONSIDERATIONS

The theoretical considerations of this study consisted of calculations for the purpose of determining the parameters of the detonation wave as it propagated into a region of continuously changing initial pressure and temperature as a result of the oncoming flow. In addition, the structure of the detonation wave propagating into a flowing combustible mixture of gas was discussed.

Theoretical Detonation Parameters

In this investigation the relative velocity of the detonation wave was measured as it propagated against an oncoming flow. Theoretically this relative velocity was considered to be the difference between the absolute detonation velocity as determined from the Chapman-Jouguet theory and the average velocity of the oncoming flow that was determined from total mass flow for subsonic flows and from the Mach number for the supersonic flows.

The theoretical absolute detonation wave velocity was calculated on the basis of the Chapman-Jouguet theory. Since the C-J theory has been widely treated in its formal gasdynamic aspects (21, 13, 6), it has not been discussed in this dissertation. The absolute detonation waves velocities depend on the initial state of the combustible gas

into which the wave propagates. The initial conditions are pressure, temperature and the composition of the mixture. In this investigation the mixture of the hydrogen and oxygen gas was selected to be stoichiometric.

Since the flow of a gas through a tube is affected by friction, the Fanno theory as described by Shapiro (18) was used to determine the temperature and pressure profiles in the flowing-gas detonation tube. The friction factor used in this analysis was based on the studies of Keenan and Neumann (11) on the measurements of friction in a pipe for subsonic and supersonic flow. Later the friction factor was determined experimentally. For subsonic flow the velocity increases and the pressure and temperature decrease as the gas flows through the tube; the opposite relationship prevails in the supersonic case. The flow was assumed to be isentropic in the convergent-divergent nozzle serving as the entrance of the FDT for supersonic flow. The Fanno theory was also used in this study in the selection of the different lengths of the FDT for the various flows as described in Chapter III.

As a result of the theoretical study of the flow through the FDT it was found that the static temperature and pressure of the gas mixture varied over a wide range. Temperatures varied from 70°K to 300°K, and pressures varied from 0.2 ATM to 2 ATM. A survey of the literature (13, 6, 1) that was published on the theoretical calculations of the detonation wave parameters based on the C-J theory did not cover these ranges of initial conditions. Therefore a computer program was prepared for the calculation of the detonation wave

parameters that were based on the Hugoniot equation and the C-J theory. Pertinent discussion and data of these calculations are presented in Appendix I.

The velocity of the flowing gas relative to the tube was established as follows: In the subsonic case an average flow velocity was determined from the experimentally measured total mass flow of the gas mixture. The area of the tube was known and an average density was calculated from measured pressures and computed temperatures. Then, from the continuity equation, the average velocity of the flowing gas was computed for various flows. In the supersonic case an average flow velocity was calculated on the basis of the design Mach number and computed temperature. Later the design Mach number was confirmed experimentally.

Structure of the Detonation Wave

In addition to the velocity measurements, photographic studies were made of the detonation wave as it propagated against the oncoming flow. The primary purpose of this part of the study was to determine what effect, if any, the oncoming flow had on the structure of the detonation wave. There has been considerable work by others on photographing of detonation waves traveling into static mixtures (4, 14, 16). The efforts have included studies on the initiation of the wave, steady-state characteristics of the wave and the spin detonation phenomena of the wave. There were various factors considered in these studies in order to describe the overall shape

and the internal structure of the wave. In this dissertation, certain generally agreed upon facts were used in order to postulate a structure of a detonation wave that is propagating into an oncoming flowing combustible mixture of gas. The salient difference is that the detonation wave is no longer propagating into a gas at rest. Also, this postulated structure was primarily concerned with the effect of the oncoming flow on the wave and also on the internal structure of the wave.

The construction of the wave consisted of two parts that included the assumptions that were made. Basically the steady state two-dimensional profile of a flow in a constant area duct was combined with a wave propagating in a static mixture. The postulated structure was developed on the basis that the detonation wave was propagating under steady state conditions.

The basic structure of the detonation wave that is propagating into a static gas is essentially the hydrodynamic model of detonation that is generally attributed to Zeldovich, von Neumann, and Doring. The wave is considered as one-dimensional and is propagating at constant velocity. The leading edge of the model of the wave is a normal shock that is followed with a very short but finite induction zone. These two zones are directly coupled to a combustion zone. At the trailing edge of the detonation wave, particles of the burned gases leave at the speed of sound in the gas.

This idealized structure must be further altered to include thermal and mechanical losses (21). Heat transfer does occur at the walls despite the speed of the wave; this effect influences reaction

rates in the peripheral region. Also, due to friction at the walls of the tube and the viscosity of the fluid, a velocity variation exists in the region behind the wave. These effects alter not only the velocity of the wave but also the shape of the leading edge of the wave. Photographic results by some researchers have found the wave shape to be concave in the direction of propagation when the mixture has been near the detonation limits or during the latter stages of development of the wave (14). But, when the mixture has been near stoichiometric, the wave front was planar (16).

The flowing combustible gas into which the detonation wave propagates also has a velocity profile. Since the minimum Reynolds number for the flow in the tube was always much greater than 2300, the flow was considered turbulent and the profile was assumed to be fully developed turbulent flow. Thus, the detonation wave was considered to propagate into a fully developed turbulent flow in this study.

The combination of the ZND model that is altered by heat and friction effects and the fully developed turbulent flow of the oncoming gas led to the detonation model for this study. The result is a somewhat modified wave shape and structure. Instead of the wave front being planar it would be convex in the direction of the propagation of the detonation wave. This curvature of the wave front occurs because the velocity profile of the oncoming turbulent flow varies from zero at the walls to a maximum at the center of the tube. Thus, that part of the detonation wave nearest the wall will propagate faster upstream against the flow than the part of the

detonation wave in and near the center of the tube. A new steady state situation could result. The wave was not expected to propagate at a constant velocity because of the changing velocity of the unburned gases along the axis of the tube as predicted by the Fanno theory. The width of the shock front and induction zone may change as the oncoming velocity increases. The shape of the leading edge also may become more convex as the oncoming velocity increases. The combustion zone and process may be modified due to the oncoming flow because the wave is propagating into a region of continuously changing pressure and temperature. Finally, the overall behavior of the detonation wave may be modified due to the fact that the pressure and temperature profiles of the flowing gas along the tube axis are exactly opposite in character between subsonic and supersonic flow.

How well this model described the behavior of the detonation wave as it propagated into the oncoming flowing combustible mixture is determined from the experimental portion of this study.

CHAPTER III

EQUIPMENT FOR THE RESEARCH

The apparatus used in this research was designed for the purpose of investigating the behavior of a detonation wave in a flowing combustible mixture of gas. An overall schematic diagram of the apparatus is shown in Figure 1. It consists basically of an initiation detonation tube and a flowing-gas detonation tube. Because of the hazardous nature of these experiments, the apparatus was installed in a test cell with heavy reinforced concrete walls. An overall view of the installation is shown in Figure 2. A description of the apparatus, gas supply and control system, instrumentation and optical system is given in detail in this chapter.

Apparatus

Initiation detonation tube

Because of the difficulty of initiating a detonation wave in a high subsonic or supersonic flow, an initial consideration in this study was the initiation of the detonation wave. It was decided to provide an initiation detonation tube. An overall view of the IDT is shown in Figure 3. The tube was constructed from an 84 inch length of type-304 stainless steel tube with 1 1/2 inch inside diameter and 1/2 inch wall.

The length of the IDT was selected as 84 inches because this length provided more than sufficient distance to initiate the wave at one end in a near stoichiometric static hydrogen-oxygen mixture and to have a strong, fully developed detonation wave propagating at the other end. From the results reported by Edse and Bollinger (3) the induction distance for this mixture was estimated to be about 30 inches. The diameter of 1 1/2 inch was compatible with that used in previous experiments by other investigators in that a smaller diameter tube had undesirable wall effects on the detonation wave and a larger diameter tube would have greatly increased the mass flow requirements for the FDT.

The flange at the initiator end of the IDT was designed to mount a standard aircraft spark plug as the source of energy for the initiation of the detonation wave. At the other end of the IDT there was a diaphragm assembly for isolating the IDT from the FDT. An inlet was provided at the diaphragm end of the IDT to charge the tube with combustible gas and to act as a purge inlet. An outlet was provided at the ignition end of the IDT for escape of gas while the tube was purged.

The tube was estimated conservatively to have a bursting pressure of 60,000 pounds per square inch. The highest pressure to which the tube was subjected during the study did not exceed 40 ATM. The initiation detonation tube proved to be satisfactory under all test conditions.

Two ionization probe mounts were provided in the IDT that were 24 inches apart and located at the diaphragm end of the tube. Also,

a pressure probe mount was located near the diaphragm. Both of these installations were used only during the checkout and calibration of the instrumentation and the establishment of experimental operational techniques.

Flowing-gas detonation tube

The FDT was designed in three sections--one 3 foot section and two 2 foot sections. These lengths were indicated by a preliminary theoretical analysis of the flow in a constant area tube with friction based on the Fanno theory (18) and work by Keenan and Neumann (11). An overall picture of the FDT is shown in Figure 4. There were eight ionization probe mounts installed in the 3 foot section and five installed in each of the 2 foot sections. The FDT was constructed from the same material and diameters as the IDT. Similar consideration for selection of the diameter for the IDT pertained to the FDT. Also, the estimated bursting pressure of 60,000 pounds per square inch applied here.

Great care was taken in selecting from stock the stainless steel tube that was used for the FDT. After precision machining and reaming of the interior surface within close tolerances of concentricity and uniformity, the inside wall was honed to a mirror finish and an inside diameter of 1.564 ± 0.001 inches. Flange connections were constructed for male and female adaption with a tolerance of 0.001 inches. This care in the construction of the FDT was necessary to reduce the effects of the wall of the tube on the flow of the combustible gas into which the detonation wave would propagate--particularly in the supersonic flows of the study.

Mixing chamber

A small mixing chamber for the IDT was constructed of stainless steel for the purpose of premixing the hydrogen and oxygen prior to charging the IDT. A picture of this chamber is included in Figure 3. The volume of premixed gases was held to a minimum of 34.6 cubic inches, and the walls of the chamber were 1 inch thick. Thus, if the detonation wave that was initiated in the IDT propagated back into the mixing chamber, it would be contained. Under normal operation of the IDT combustion did not occur in the mixing chamber.

Transition section

A transition section was constructed for the detonation wave that was initiated in the IDT to propagate through into the FDT. A schematic diagram of the transition section is shown in Figure 5. The transition section was in two parts. One part included the flange nut for the diaphragm assembly and attached to the IDT. The other part provided a divergent section for the flowing combustible gas to exit from the FDT and it was attached to the exit of the FDT. The sketch shown in Figure 5 indicates an area change for the detonation wave propagating upstream from the IDT into the FDT. Because of the design of the transition section the flowing gas that exited from the FDT encountered an area change and a change in the flow direction.

Stagnation chamber

A stagnation chamber was provided for the FDT. This chamber was made of the same material as the FDT and IDT--stainless steel. The hydrogen and oxygen gases entered this chamber at one end. The two

jets directly opposed each other. The other end was connected directly to the FDT for the subsonic flow experiments. For the supersonic flow experiments, it was connected to the nozzle section which was connected to the FDT; therefore it was designated as the stagnation chamber. The interior surface of the stagnation chamber was only roughly finished. This condition plus the two directly opposing jets appeared to provide good mixing of the two gases. A thermocouple was installed in the chamber in order to detect any burning in that area which would actuate an automatic purge system. Also, a static pressure port was provided at the exit of the chamber.

Nozzle section

A nozzle housing was constructed into which an insert for Mach 2, 3, and 4 flows could be installed. The housing was made of stainless steel, but the inserts were made of brass in order to facilitate the machining of the nozzle contours. The nozzle design was based on the results of studies reported by Keenan and Neumann (11).

Exhaust duct

An exhaust duct was provided in which to dilute and discharge the flowing combustible gases prior to detonation. A schematic diagram of this duct is included in Figure 1. The IDT and the transition section were installed in the exhaust duct. A small entrance was provided in the exhaust duct to replace the mylar diaphragm. The exhaust duct was fed air from two sources for the purpose of diluting the flowing combustible gas that exited from the part of the transition section that was attached to the FDT. One

source of air was from a blower that provided a continuous supply of 1500 scfm. The other source of air was from a high-pressure compressed air trailer that could provide up to 4000 scfm additional air. The exhaust duct was also made of stainless steel with 3/16 inch wall thickness. Thus, the exhaust duct was able to contain and discharge the flow prior to and during detonation. Also, on a few occasions, it withstood severe, rapid burning, perhaps even detonation, when the air dilution system malfunctioned.

Diaphragm assembly

The diaphragm assembly was located at the downstream end of the IDT. It is shown in Figure 5. The purpose of the diaphragm was to separate the IDT from the FDT during system operation. The diaphragm, itself, was simply a circular piece of mylar that was 3 inches in diameter and 0.002 inches thick. Access to the diaphragm assembly was through a port in the exhaust duct.

Ignition system

The combustible gas was ignited in the IDT by use of a standard aircraft spark plug with modification to the electrodes. The modified ignition source is shown in Figure 6. The center electrode was extended 2 1/2 inches and the four ground electrodes were replaced with one electrode that formed a 1/32 inch gap with the center electrode. Both of these electrode extensions were made from hard steel of 1/8 inch diameter. A 5000 volt AC power source was connected to the spark plug. The flange into which the spark plug was mounted was insulated from the IDT. This insulation decreased the possibility

of the ignition triggering the oscilloscope. The ignition system proved to be very reliable in providing the energy source to initiate the detonation.

Gas Supply and Control System

The gas supply and control system used in this research consisted of a basic system with some modification. Originally this system had been used for the operation of small rocket motors (12). A sketch of the modified system is shown in Figure 7. The hydrogen and oxygen gases used in the present investigation were stored externally to the building. The oxygen gas was supplied from a number of standard cylinders through a manifold into the test cell. The hydrogen was supplied from a thirty-eight tube, high-pressure gas trailer through a high-pressure hose into the test cell. The air, that was used for control, dilution and purge, was supplied from another thirty-eight tube, high-pressure gas trailer.

The hydrogen and oxygen gases were fed and controlled through two identical, parallel, metered, high-pressure lines in the test cell. These flows were automatically and remotely controlled from the control room located next to the test cell. The main control console is shown in Figure 8. An observation window and mirror were located between the control room and the test cell for the purpose of viewing the port in the exhaust duct through which the diaphragm was changed after each detonation. Through this port, a fire ball would appear upon detonation that resulted from the detonation wave propagating upstream through the transition section.

The flow of the gas through the supply system will be traced briefly (Figure 7). Since, as stated, the hydrogen and oxygen lines were identical, only the oxygen line will be described. The oxygen entered the test cell under high pressure. This pressure was reduced to the pressure desired for each experiment through a dome regulator valve; then, the gas passed through a standard venturi meter. From here, the gas was directed to either the IDT or the FDT.

Since the air was used for both dilution and purge, each function will be described separately. The air that was used for dilution was first passed through a dome pressure regulator valve that was pre-loaded in the test cell prior to each series of experiments for a particular mass flow of combustible gases. The pressure to be set was based on the calibration of the overall dilution system in the exhaust duct that would result in the exhaust gas mixture having less than ten percent of hydrogen by volume. The activation of this air dilution was performed through an electrically operated automatic solenoid valve in the control room.

The air that was used for purging the system after a detonation entered the system at two points. At the first point the air, which was the purge system for the small rocket motors that had been operated here, entered the hydrogen and oxygen feed lines upstream of the venturi meters. Thus, with the automatic solenoid valves to both the IDT and FDT open, the whole detonation system would be purged. This purge operation, which was initiated automatically from the control room, also released the pressure in the domes of the pressure regulating valves thus stopping the flow of hydrogen and

oxygen. The second purging system was installed after some difficulty had been encountered in shutting down the flow after a detonation. This additional purge system supplied air directly to the stagnation chamber of the FDT and it was operated through a solenoid valve in the control room. This source of purge air was obtained by re-directing the dilution air from the exhaust duct, where it obviously was not required after a detonation, to the FDT. This provided not only a purge of the FDT but also an abrupt shutoff of hydrogen and oxygen to the FDT by closing the check valves in each of the lines since the air pressure was always considerably higher than that of either the hydrogen or oxygen at this point.

As a safety feature, an automatic purge and shutdown system controlled through a thermocouple was installed into the control system. The thermocouple was installed in the stagnation chamber of the FDT. Then, if a preset temperature limit would be reached in the stagnation chamber during any phase of a detonation experiment, a relay would be energized that would open the circuits on the control panel that would cause automatic purge with air through the FDT and shutdown of the flow of hydrogen and oxygen.

Instrumentation

The instrumentation system for this research consisted of the following components that are described in detail: ionization probes, probe detector output circuits, oscilloscope with raster, and

oscillograph. A schematic diagram of this system (less the oscilloscope which is shown in Figure 8) is shown in Figure 9.

Ionization probes

The ionization probes were mounted in the FDT for the purpose of detecting the passage of the detonation wave. As shown in Figure 4, probes were provided along the length of the FDT. Spacing between centers of adjacent probes was 4.000 ± 0.001 inches between intervals except at the flanges.

The probes were assembled in a boss and installed in a mount that was welded to the FDT. A sketch of the probe design and boss is shown in Figure 10. The design of the probe was a single electrode with insulation. The wall of the FDT acted as the second electrode. During the subsonic experiments the single electrode probe was a copper wire of 0.051 inches diameter with a high temperature resistance teflon insulation of 0.0025 inches. This probe proved unsatisfactory because the teflon could not withstand the high temperatures that were encountered during accidental detonation of the FDT. A modified design was constructed that used the same mount and boss. It consisted of teflon "spaghetti" as the insulator and highly corrosive resistant steel safety wire of 0.032 inches diameter as the electrode which was threaded into the teflon. The overall diameter was 0.068 inches. Only the single electrode probe with its insulation passed through the 1/2 inch wall of the detonation tube. Its length was such that when the boss assembly was secured in the mount on the FDT, the end of the electrode was flush with the inner

wall. The hole in the FDT for the early design was 0.0625 inches diameter and for the later design it was 0.070 inches. This gave a gap between the probe electrode and the wall of the FDT of approximately 0.005 inches for the former and 0.019 inches for the latter.

The early design of the probes required considerable attention. Moisture and high temperatures would cause shorting of the probes. Thus it was necessary to check each probe prior to each run. Sometimes the probe electrode needed to be only wiped clean, but other times the teflon insulation was so badly damaged at the tip that it had to be repaired. The modified design of the probes required no maintenance or inspection.

Probe detector output circuits

The ionization behind the detonation wave was used to detect the passage of the wave. To detect the ionization, a special output circuit was required in conjunction with the probe. A diagram of this circuit is shown in Figure 11 which is based on a circuit that was suggested Gaydon and Hurle (7).

In this circuit a capacitor is charged to a negative voltage which is applied across the probe electrode and the tube wall. The passage of the detonation wave front is detected by the discharge of the condenser across the gap between the probe and the wall, which gives a positive voltage pulse across a resistor. This pulse is recorded on the oscilloscope. The shape of the pulse is controlled by proper selection of the capacitor and resistor. A 500 volt DC

supply was found suitable in this study although other voltages were tried.

Oscilloscope with raster

The principal component of the detonation velocity measurement system utilized throughout this experiment was a Tektronix oscilloscope with a raster modification. This equipment is shown in Figure 8. The oscilloscope with the raster was selected because it provided a measurement of the probe inputs over the long length of the FDT and simultaneously gave high accuracy in the time intervals between the probe outputs.

These two facts are inherent in the raster feature of the oscilloscope since it is simply an extension of the sweep. This extension of the sweep is accomplished by a voltage which decreases linearly over a time that is longer than the sweep duration and which is applied to the Y plates of the oscilloscope. The result is a display that consists of a repetitive series of single sweeps which are separated in the Y direction. This is referred to as a raster display, and the signals from the probes are impressed on this wave form; thus, the outputs of many probes could be monitored during the extended sweep time.

In this experiment the time that was required for the detonation wave to propagate through the maximum length of the FDT was approximately 750 microseconds. In order to have a time resolution on the oscilloscope of 10 microseconds per centimeter, the raster feature had to present an extended sweep equal to the 750 microseconds. If

one chose to utilize a single sweep length of 8 centimeters, then the raster feature had to be set to give at least 10 raster lines for this case. Therefore, since the probes in the FDT on the average were 4 inches apart, the probe output signal would be impressed on the raster sweep at approximately every 35 microseconds or every 35 millimeters. Thus, the propagation velocity of the detonation wave could be determined very accurately, corresponding to an accuracy of better than $\pm 1/2$ microsecond.

The trace of this event displayed on the oscillograph was recorded by a Polaroid camera. A special lens assembly was used to minimize distortion. Thus, the data were immediately available and could be evaluated for each experiment. An example of these photographs of a typical experiment is shown in Figure 12.

This equipment was purchased from the Tektronix, Inc. The oscillograph is basically Model 745B with modification 116B, which is the modification for the raster and is built directly into the oscilloscope. The camera and lens assembly were Tektronix type C-12. This equipment was easy to operate and with the exception of one minor breakdown it was very reliable.

Oscillograph

Another principal component of instrumentation used in this experiment was an oscillograph. It was used to record the following data: temperature, pressure and differential pressure at the venturi meters for the hydrogen and oxygen gas supply lines and the output of a pressure transducer that was placed in the wall of the stagnation

chamber. The first quantities were used to compute the mass flows of hydrogen and oxygen into the FDT. The stagnation pressure was obtained for the purpose of correlating the calibration flows of air with the hydrogen-oxygen flows in the FDT; this pressure data was used primarily in the supersonic flows in the FDT.

The oscillograph was an eighteen channel Consolidated Electronics Corporation (CEC) Visi recorder with a CEC oscillator power supply, type 2-105A, and eight 3-KC carrier amplifiers, type 1-113B. Calibration was accomplished for all pressure transducers by applying a known pressure. The calibration factor was found to be a constant for the range of pressures that were encountered throughout the experiment.

Since the recorder provided a direct reading of the data, mass flows and stagnation pressures could be determined immediately after each run for quick correlation with the data from the oscilloscope on the propagation velocity of the detonation wave.

The oscillograph equipment, pressure transducers, and related circuits required considerable effort to checkout and calibrate, but once this was accomplished, no further difficulty was encountered.

Optical System

An optical system was designed and constructed for the purpose of photographing the detonation wave as it propagated into the oncoming flowing combustible gas. A picture of this system is shown in Figure 13 which reveals its installation in the FDT of the system.

The optical system consisted of a viewing section as shown in Figure 14, of a spark light and synchronization system shown in Figure 15 and of a modified Toepler schlieren system shown in Figure 16. The viewing section was designed and checked out by Haars (9) as an independent study under the supervision of the author of this dissertation.

The viewing section was made of a stainless steel tube 26 inches long with 1 1/2 inch inside diameter and a 1/4 inch wall. In order to achieve a large viewing area of the detonation wave, the circular tube was pressed to an oval shape at the middle of the section which resulted in 1 inch by 5 inch windows. The viewing area did not expose the entire profile of the wave; there was 0.422 inches on each side of the wave profile that was not visible since the width of the tube was 1.844 inches at this point. But, the view of 1 inch of the wave profile was a considerable improvement over the width of viewing sections that was usually obtained with circular tubes. The transition from the circular cross section of the other sections of the FDT to the oval section of the viewing section was very smooth and gradual. Vycor glass was found to be the most suitable for the windows. Four ionization probes were mounted in the viewing section in order to measure the relative velocity of the detonation wave as it propagated through this section. A Kistler pressure transducer was mounted downstream of the windows for the purpose of triggering the spark light in the schlieren system.

The spark light and synchronization system consisted of a pressure transducer and associated amplifier, an oscilloscope,

time-delay pulse generator, spark light power supply and a spark light. This system was typical of such systems that are used with schlieren systems to photograph fast occurring events. The spark light had a spark duration of less than 1/2 microsecond.

The schlieren system that was used was a modified Toepler type. One major modification of the schlieren system that was different from the usual type was the replacement of the knife edge with a black dot of 1/16 inch diameter. This feature was primarily introduced because the spark light source was a point source and the black dot diameter was made the same size as the aperture of the light. The black dot was located on the plane mirror that was located at the focal point of the focusing parabolic mirror. Because of the self-luminosity of the detonation wave, the reflecting area of the plane mirror was reduced with a mask which resulted in a reflecting area on the plane mirror of 1/4 inch diameter less the 1/16 inch diameter of the black dot. Also, in order to reduce further the washing out of the film from the afterglow of the detonation wave, a filter was used. The filter passed only light in the range of 3500 ± 500 angstroms. This combination of the mask and filter still permitted sufficient light from the spark light to pass and to obtain a photograph of the detonation wave. It should be emphasized that this modification to the schlieren system resulted in recording only small density gradients that were present as a result of the detonation wave and blanked out the large density gradients. As stated, this was necessary to prevent fogging of the film by the

self-luminosity of the detonation wave. A standard camera bellows with a Polaroid camera back was used to photograph the wave.

To confirm that the detonation wave was photographed and not some other disturbance in the viewing section, the position of the wave in the photograph could be correlated with the discharge of the spark light. The spark light gave off sufficient electrical noise to be recorded on the oscilloscope with the signal from the probe. Therefore, knowing the velocity of the wave and the time the spark light discharged, the position of the wave in the viewing section could be checked.

CHAPTER IV

EXPERIMENTAL TECHNIQUES AND PROCEDURES

The experimental techniques and operational procedures that were developed and used in this research are discussed in detail for the purpose of revealing the step-by-step developments of the research.

Initiation Tube Experiments

An initial phase of this experiment was to operate the initiation detonation tube. The IDT with its ignition system, diaphragm assembly, and mixing chamber were assembled as shown in Figure 3. As stated in Chapter III two ionization probes were installed in the IDT near the diaphragm end and were spaced 24 inches apart. The section of the gas supply and control system that was applicable to the IDT as shown in Figure 7 was put into operation. Over a hundred experiments were made in checking out the IDT and probes.

The operational procedure during this phase of the research was as follows: The loader valves in the control room for hydrogen and oxygen were set to the desired pressure in order to provide a near stoichiometric mixture of flow. The automatic solenoid valves to the mixing chamber were opened. The run switch that started the flow of hydrogen and oxygen to the mixing chamber was actuated. Thus the

gases entered the mixing chamber where premixing took place and then the combustible gas flowed into the IDT. The gas entered the IDT near the spark plug and exited through an atmospheric vent near the diaphragm at the opposite end. The gas was permitted to flow for approximately 5 seconds. During this time a minimum of 150 tube volumes of the premixed combustible gas passed through the tube; thus, the IDT was purged and filled. The flow was stopped through the pressure regulating valves and the automatic solenoid valves to the mixing chamber were closed. This last step prevented any leak through the pressure regulating valve in the feed system from affecting the mixture of gas in the IDT. Then the ignition switch was operated. Firing of the IDT was delayed up to 30 seconds since this time was applicable to the operation of the complete system that was required when the FDT was put into operation.

These experiments with the IDT resulted in considerable experience that later proved extremely valuable when the complete detonation system was operated. At times the ignition source would trigger the oscilloscope; proper shielding of the ignition cable and grounding of the spark plug mount eliminated this undesirable condition. Also many different designs of the spark plug electrodes were tried before the design shown in Figure 6 was found to be satisfactory. Several different probe detector circuits and voltages on the probes were tested before the circuit in Figure 11 was selected and repeatability of operation was achieved.

Calibration of the Flowing-Gas Detonation Tube

Another initial phase of this experiment was the calibration of the FDT with air. This calibration with air was for the purpose of studying the flow characteristics of the FDT. The main objectives were to determine the friction factor of the mirror-finished wall of the FDT, the effect, if any, of the transition section that was attached to the exit of the FDT, and to establish reference conditions for the supersonic experiments.

The friction factor of the FDT was determined by measuring the pressure drop through the tube. The mounts for the ionization probes that were spaced along the tube were constructed so that a manometer tube could be connected to the top of each probe. Therefore, when the center electrode of the probe was removed, a source of static pressure was available. Data were obtained over the complete range of subsonic mass flows that were planned for the experiments.

The investigation of the effect of the transition section on the flow through the FDT indicated no adverse problems. As shown in Figure 5 the flow changed direction and the area could be adjusted by moving the IDT forward or backward. Both static and total pressure probes were used to check behavior of the flow for various positions of the transition section which would result in an area change. It was found that with a small increase in the exit area of the FDT with the transition section over the area of the FDT, the flow characteristics that were based on pressure measurements did not change. Thus the exit area of the FDT at the transition section was made

approximately fifty percent greater than the area of the FDT. The primary concern was to be sure the transition section had no adverse effect on the flow in the FDT.

The flow of air through the tube was investigated also for each set of supersonic experiments. This was for the purpose of studying the static pressure profile along the FDT for each Mach number. With the instrumentation that was available for this study this was the method that was used to determine if the flow was supersonic and free of strong disturbances in the tube. Also, a static pressure probe that was located in the stagnation chamber just prior to the nozzle was used to determine the approximate desired stagnation pressure for the supersonic runs with hydrogen and oxygen. The procedure was to increase the flow of air through the tube until the static pressure profile from the nozzle exit to the end of the FDT was one that increased gradually to atmospheric pressure without any indications of discontinuities of pressure along the tube. Then the pressure noted on the static pressure probe in the stagnation chamber was used as a reference to establish run conditions for supersonic experiments. It should also be noted here that the computed mass flow for supersonic conditions was used also as a reference to establish run conditions for the supersonic experiments.

Operation of the Detonation System

The operation of the complete detonation system involved both the simultaneous and proper operation of many pieces of equipment. Thus a thorough checklist had to be prepared and followed for each experiment. The step-by-step operation of the detonation system is discussed in the following paragraphs.

Prior to each day of operation the system would be inspected. The gas supply and control system would be checked to determine that all regulating and control valves were readied for proper functioning with the detonation system. This procedure was necessary since this facility was being used jointly to operate small rocket motors. Next adequate quantities of hydrogen, oxygen and air had to be available. A frequent recheck of these quantities had to be made if several experiments were conducted during the day. This recheck was particularly true if large mass flows were demanded from the gas supply system.

A complete inspection of the apparatus was made. The ionization probes would be checked with an ohmmeter to determine their condition. The power supply for the probes would be warmed up and checked for proper voltage. The ignition source would be removed, inspected and cleaned. Then after being replaced, it would be checked out for proper operation from the control room. The diaphragm section would be opened and inspected and a new mylar diaphragm installed. This step was necessary after each firing of the system. The thermocouple in the stagnation chamber that was the sensing element that actuated

the automatic shutdown system was removed, inspected and tested for satisfactory operation. The ice bath for the thermocouples that measured the temperature of each gas prior to the venturi meters was readied for operation.

Next the oscilloscope was prepared for operation. After a thirty minute warm-up period, it would be checked out. The desired time of the raster sweep would be computed for the experiments that day and set on the oscilloscope. The proper triggering of the oscilloscope would be checked with a device that was made to simulate the firing of a probe. The ignition would be checked several times to insure that it would not trigger the oscilloscope. The camera and lens assembly would be checked for proper setting and operation.

Then the oscillograph would be readied for operation. It also required at least a thirty minute warm-up period. The amplifiers of the oscillograph had to be calibrated prior to operation each day. This is a standard procedure that is involved with such equipment and was not described here.

When the optical system was installed in the detonation system, it also required preparation and checkout each day prior to operation. The electronic equipment of the spark light and synchronization system had to be warmed up and checked for proper operation. The schlieren system had to be checked for proper alignment and focus. The remote operation of the camera shutter from the control room was checked and the ignition system for the detonation wave was checked to insure it did not trigger the spark light.

After satisfactory checkout of the foregoing items the control panel would be put into operation. The control panel had been designed to insure many fail-safe features in its operation with the small rocket motors (12). As many of these features as possible were included in the operation of the detonation system. The operation of the control panel for a typical experiment was as follows: The optical system for photographing the detonation wave was readied for remote operation from the control room for those experiments that included the optical system as part of it. The blower was turned on. The hydrogen, oxygen, air dilution and air purge loaders were set to the desired pressures. The IDT was charged. The oscillograph was started. The air dilution for the exhaust duct was turned on. The flow through the FDT was started. After five to ten seconds (depending on the mass flow) the camera on the oscilloscope was opened. Then, simultaneously, the ignition and the purge were actuated. The camera was then closed and the oscillograph stopped. The control panel was returned to the start configuration.

Then, a preliminary analysis of data from the oscilloscope photograph, the schlieren photograph (if applicable) and the oscillograph record was made. Thus, if everything worked properly--a good experiment. Many man-hours of effort were involved before experiments that could be repeated with success were achieved.

CHAPTER V

RESULTS

Theoretical Investigations

The results of the theoretical investigations provided the basis with which to compare the experimental results. The results of the calculations that were carried out are shown in the graphs in Figures 17, 18 and 19. The range of initial pressures and temperatures applicable to this study were increased slightly beyond that predicted by the Fanno theory simply for the purpose of completeness and of interest. These graphs indicate the variations of the final temperature, final pressure and the absolute C-J detonation wave velocity respectively, with the initial conditions of pressure and temperature. Then, in the graphs in Figures 20 and 21 were plotted the initial temperatures and pressures that corresponded to subsonic and supersonic flows in the FDT respectively. In these two figures the abscissa of the graphs represents the Mach number of the unburned gas as it would appear in the tube with an exit Mach number of 1 for either subsonic or supersonic flow. The detonation wave parameters associated with these conditions in the FDT were tabulated in Table 1 in Appendix I.

Finally, the theoretical variation of the different velocities associated with the detonation wave is shown in Figures 22 and 23

for subsonic and supersonic flows respectively. The velocity of the detonation wave relative to the tube in each case is the difference between the absolute C-J velocity of the detonation wave and the velocity of the oncoming flowing gas (unburned gas). The detonation wave velocity relative to the tube obtained from this theoretical analysis was the velocity with which the experimental relative velocity data from the ionization probes were compared.

Experimental Investigations

The experimental portion of this study measured the relative velocity of the detonation wave as it propagated into the oncoming flowing combustible gas and photographed the profile of the wave under these conditions. Seventy-seven experiments were conducted at subsonic flow velocities which were for twelve different mass flow rates. Twenty-two experiments were conducted that covered the range of supersonic flows in which the flowing-gas detonation tube was fed with the Mach 2, 3 and 4 nozzles. In addition, fifteen experiments were conducted in which the profile of the wave was photographed. These experiments were those from which usable data were obtained.

The subsonic experiments were conducted with two 2 foot sections and one 3 foot section that made up the FDT except the last series of subsonic experiments were made with the 3 foot section removed. The twelve different mass flow rates varied from 0.099 to 0.713 lbm/sec. This corresponded to average Mach numbers of 0.14 to 0.66 for the flow of unburned combustible gas in the FDT. The higher flow rates

resulted in the FDT being choked at the exit. From the seventy-seven subsonic experiments, one was selected from each of the twelve different mass flow rates that was representative and had a mixture ratio near stoichiometric. The experimental data of these twelve experiments were tabulated in Table 2, and the relative velocities of the detonation wave were tabulated in Table 3. In Figure 23 were plotted for comparison the experimental and the theoretical relative velocities of the wave against the average Mach number of the oncoming flow of unburned gas.

The supersonic experiments were conducted in the following configurations of the FDT: the Mach 2 nozzle fed into a 2 foot section while the Mach 3 and 4 nozzles fed into two 2 foot sections. The mass flow rates were over 0.80 lbm/sec for all supersonic experiments, which exceeded the 0.782 lbm/sec that was theoretically computed as necessary. The stagnation chamber pressures always exceeded the theoretical values required. From the twenty-two experiments, several were selected from each of the three different supersonic flows; the experimental data was tabulated in Table 4, and the relative velocity of the detonation wave was tabulated in Table 5. In Figure 25 were plotted for comparison the experimental and the theoretical relative velocities of the wave against the average Mach number of the oncoming flow of unburned gas.

The data presented in Tables 3 and 5 of the relative velocities of the detonation wave were obtained from the photograph of the oscilloscope. The experimental data presented in Tables 2 and 4 were determined as follows: The mass flow rates and mixture ratios were

obtained from the pressures, differential-pressures and temperatures at the venturi meters in the gas supply lines that were recorded on the oscillograph. The theoretical absolute velocity of the detonation wave was the Chapman-Jouguet steady-state velocity that was plotted in Figures 19 and 26. The average flow velocities for the subsonic flows were determined from the continuity equation. The average velocities for the supersonic flows were determined from the average Mach number in the tube and the speed of sound that was based on an average flow temperature that was determined from the Fanno theory. The other data presented in Tables 2 and 4 are self-explanatory. Refer to Appendix III for details of data reduction.

Over seventy experiments were conducted with the optical system installed in the detonation system. Ten of these experiments were conducted with supersonic flow conditions. The schlieren photographs in Figures 27 through 34 are representative of the many photographs taken. The flow conditions that are applicable to that photograph are presented beneath it. The determination of these flow conditions is similar to that which was explained for the subsonic and supersonic experiments. No results were obtained with the Mach 2 nozzle because it was found that a shock was located between the nozzle and the viewing section. This standing shock was due to the fact that the minimum area in the viewing section was not large enough to permit the shock to move downstream. This phenomenon is analogous to the starting of a supersonic wind tunnel.

The investigation of the flow characteristics of the detonation tube with air gave the following results. From the static pressure

data the average friction factor of the tube was calculated to be 0.006. The flow of air for all supersonic configurations of the tube did not indicate any shocks in the FDT or viewing section when it was used. The static pressure profile in the tube was in good agreement with that calculated from the Fanno theory. The supersonic Mach numbers in the viewing area were determined from a schlieren photograph of an artificial Mach line; the results were in good agreement with the design Mach numbers.

The study encountered a problem of accidental detonation of the flowing hydrogen and oxygen gases. This means that without normal ignition the gas would detonate during the time when the flowing gas entered the tube and prior to the planned time of detonation. The cause of these accidental ignitions was not discovered. The accidental detonation occurred at random. It occurred at low subsonic velocities but more frequently at supersonic velocities. Several oscilloscope photographs were obtained with these accidental detonations. Only one photograph was obtained during a supersonic test which was with the Mach 2 nozzle. The relative velocity of the detonation wave for this experiment was found to be 11,465 feet/sec. This velocity was in good agreement with the velocity that would be predicted for the wave traveling with the flowing gas under these conditions (see experiment No. S-2-1 in Table 4). Four oscilloscope photographs were obtained of the accidental detonation at subsonic conditions of approximately 800 feet/sec of flowing gas. Here, the average velocity was 10,300 feet/sec which also was in good agreement with expected results for the wave traveling with the flow. But the

detonation wave did not always travel with the flow; oscilloscope photographs showed that two accidental detonations traveled against the flow. With the installation of direct purge of air into the stagnation chamber and automatic shutdown devices, the accidental detonations presented no problem. The experiments that were planned for the study were achieved in spite of these difficulties.

CHAPTER VI

DISCUSSION OF RESULTS

General

The behavior of a detonation wave in a flowing combustible mixture of gas is analyzed from the viewpoint of comparison of the experimental results and the theoretical results. In general, the subsonic experimental results are in agreement with the theoretical calculations. The velocity of the detonation wave relative to the tube was less than the absolute C-J steady velocity by the amount of the speed of the oncoming flow of unburned gas. Then in the supersonic experiments, the relative velocity of the detonation wave did not decrease as was expected; the wave velocity relative to the tube was always greater than the difference between the absolute C-J steady velocity and the velocity of the oncoming flow of unburned gas. In other words, it appeared that the absolute C-J velocity was not independent of the oncoming flowing-gas velocity. The photographic results are generally in agreement with the theoretical predictions. The discussion of the results are divided into three parts: subsonic flow results, supersonic flow results and photographic results of detonation.

Subsonic Flow Results

The experimental results of the subsonic experiments are generally in agreement with the theoretical calculations. In Figure 24 and Table 2 are shown the comparison of the relative experimental detonation velocities with the theoretical velocities. The theoretical analysis of the detonation parameters based on the subsonic flow conditions revealed results of slight interest as compared to the supersonic flow conditions which are discussed in the next section of this chapter.

In Table 3 were tabulated the subsonic data of the velocity measurements between the ionization probes. The experiment numbers indicate the twelve experiments that were selected as representative of the seventy-seven subsonic experiments. The letters A through L represent the different mass flow rates as indicated in Table 3 and the numbers after the letters indicate the particular experiment at that mass flow rate. The probes were numbered in the direction of the propagation of the detonation wave and in all cases started with number one at the exit of the tube. The last probe at the entrance to the tube was eighteen in the subsonic configuration (with the exception of experiment No. L-2 which as stated before had only two 2 foot sections of tube--thus only ten probes). The distance between the probes is indicated at the bottom of Table 3.

Analysis of Table 3 indicates that the velocities between the probes did not vary much for each experiment (the velocities could be in error as much as ± 150 feet/sec). But Figure 22 indicates that

the theoretical relative velocity of the detonation wave increases as the wave propagates through the tube against the flowing gas. The explanation is simple. The length of the FDT for the subsonic tests was approximately 100 inches. Therefore the effect of friction on the flow was small for this length of tube according to the Fanno theory. The corresponding small decreases in temperature and pressure had little effect on the absolute Chapman-Jouguet steady wave velocity. Thus the relative wave velocity did not vary much for a specific mass flow rate. But as the mass flow rate increased for the 100 inch tube, the average flow velocity increased until finally at approximately a mass flow rate of 0.55 lbm/sec the tube was choked at the exit. In order to confirm this condition, experiment No. L-2 was conducted in which the tube was shortened to approximately 64 inches. A mass flow rate of 0.713 lbm/sec choked this configuration. Hence, in Figure 24 was plotted the average Mach number of the unburned gas against the experimental relative velocities of the detonation wave. Agreement with the theoretical relative velocities is good.

Additional analysis of the subsonic experiments considered the behavior of the detonation wave through the transition section where the wave passed through approximately 12 inches of a stagnate mixture of air and combustible gas. At this point the detonation wave encountered an area change and abruptly an oncoming flow of combustible gas. From the subsonic data in Table 3, the effect of this environment in the transition section on the behavior of the detonation wave as it entered the FDT was analyzed. At first, it was suspected that

the wave had quenched because the first several probes in the FDT did not fire in some experiments. But after the probes were modified, if a wave developed in the IDT, every ionization probe in the FDT fired each time. The first probe was located approximately 8 1/2 inches upstream in the FDT. Therefore, if the detonation wave was quenched as it propagated through the transition section into the FDT, the wave was fully redeveloped again at the first probe. Also, the initial velocities that were recorded in the first part of the FDT revealed no sudden change due to the flowing gas. Further analysis of the velocities between probes for all the subsonic flows did not show any major variations; therefore, it was considered that the wave was propagating in the flowing gas in a steady condition.

In Figure 20 is shown the final temperature and pressure behind the detonation wave as it propagated upstream against the unburned, subsonic flow of gas. It should be noted here, because it will be referred to again in the analysis of the supersonic flows, that the pressure and temperature decreased behind the detonation wave as it propagated upstream. This environment is compatible to the existence of the formation of rarefaction waves that are essential in the Chapman-Jouguet theory in order to have a steady wave that is propagating at a constant velocity and where the burned gases at the exit of the detonation wave have a speed of Mach 1 with respect to the burned gas.

Supersonic Flow Results

In Figure 25 and Table 4 the experimental and theoretical velocities relative to the tube of the detonation wave are shown as the wave propagated against an oncoming supersonic flow of combustible gas. The relative velocity of the detonation wave did not decrease as was expected; the wave velocity relative to the tube was always greater than the difference between the absolute C-J steady velocity and the velocity of the oncoming flow of unburned gas. In the Mach 2 test the experimental relative wave velocity is approximately 200 feet/sec greater than the theoretical relative wave velocity; in the Mach 3 it is approximately 500 feet/sec greater and in the Mach 4 test it is approximately 1500 feet/sec greater. Thus it appeared that the absolute C-J velocity was not independent of the oncoming flowing-gas velocity.

The theoretical analysis of the detonation parameters based on the supersonic flow conditions revealed many interesting results which are considered pertinent to the analysis of the experimental data. In Table 1 were tabulated the results of the theoretical calculations. The absolute Mach number of the detonation wave increased as it propagated into the decreasing temperature of the oncoming flow. The final temperature in the burned gases decreased only about 5% while the initial temperature of the unburned gases decreased about 72%. Both the pressure and temperature ratios of the burned gas to the unburned gas increased by a factor of about 3.3. Thus the strength of the detonation wave increased and the

temperature and pressure gradients in the front of the wave, assuming a normal shock condition, increased considerably as shown in Figures 35 and 36. As was expected, the heat added during the combustion in the detonation wave was fairly constant. But the graph in Figure 21 brought out the most interesting result of the increasing pressure profile behind the detonation wave as it propagated upstream. These theoretical results did suggest that the behavior of the detonation wave in a supersonic flow might be different from those predicted.

Was there supersonic flow during these experiments? In previous discussions in this dissertation five facts were stated that verified that there was supersonic flow in the tube. Briefly summarized here the facts were that the static pressure profile in the tube was in good agreement with theory; the area ratio of the nozzle was precisely machined; the mass flow rate always exceeded the theoretical amount that was required; the stagnation chamber pressure was always greater than the theoretical pressure that was required; and schlieren photographs of an artificial Mach line indicated Mach 3 and Mach 4 flows entered the tube. Furthermore, Figures 31 and 32, which are the schlieren photographs of the detonation wave in the Mach 3 and Mach 4 flows respectively, indicate that the flow conditions were different and the velocity profile of the Mach 4 flow was stronger than that of the Mach 3 flow. Therefore, these facts did indicate that there was supersonic flow in the tube.

In Table 5 was tabulated the supersonic data of the velocity measurements between the ionization probes. The experiment numbers indicate the supersonic experiments at each Mach number that were

selected as representative of the twenty-two supersonic experiments that were made. The letter "S" indicates supersonic; the number that follows the letter "S" indicates the Mach number; and the number following that indicates the particular experiment at that Mach number. The probes were numbered in the same manner as it was described for the subsonic experiments. The distance between the probes is indicated at the bottom of Table 5.

Analysis of Table 5 indicates that the velocities between the probes did vary. The relative wave velocity changed, but only slightly. The velocity between the first set of probes was higher than the velocity between the last set of probes, probably because of the wave abruptly entering the oncoming flow. But after the first set of probes, the velocity between probes was approximately the same as the average relative velocity of the wave for that experiment. But from the graph in Figure 25 the observed relative wave velocity is greater than the theoretical velocity. The theoretical decrease in velocity is due to the frictional effects considered in the Fanno theory and not from the decreasing pressure and temperature into which the wave was propagating. In Figure 23 the theoretical absolute detonation wave velocity did not vary much because even though the theoretical temperature and pressure varied considerably as is shown in Figure 21, the initial density of the gas did not vary to any extent.

Even though the theoretical models that were used for comparison with the experimental results were over simplified, the difference in velocities should not have been as large as observed. Also, in this

case the experimental wave velocities should have been less than the theoretical ones because the actual model was three-dimensional, had boundary layer interaction and had losses of energy due to heat transfer to the walls, which were not considered in the theoretical calculations. It appears that the average experimental absolute propagation velocity of the detonation wave with respect to the unburned gas was as high as 10,780 feet/sec for the Mach 4 test as compared to the theoretical absolute Chapman-Jouguet steady velocity of approximately 9300 feet/sec for those initial conditions. Such waves having velocities that are higher than the Chapman-Jouguet velocities are described in the literature (7, 17, 19) as "strong" or "overdriven" detonation waves. Therefore, what phenomena in this study brought about the condition of a strong detonation wave in the FDT?

In order to elucidate the phenomena, the details of the flow condition in which the strong detonation wave was observed shall be discussed. When the detonation wave was fully developed in the IDT in a 1 ATM static environment, the pressure in the burned gases would have been approximately 19 ATM. Then when the wave propagated through the diaphragm and into the transition section where the stagnate gas could have been at least 2 ATM, the pressure in the burned gases would have increased to 50 ATM or higher since the gas temperature would probably be lower than ambient temperature. Now as the wave propagated against the flowing gas, it entered a region of decreasing pressure due to the supersonic flow in the tube as was brought out in the discussion of the theoretical results. Here the burned gases

would have had a pressure profile as shown in Figure 21. Initially, in the FDT the exit pressure could have been as high as 22 ATM decreasing to 10 ATM at the entrance to the FDT. But the important fact observed here was that the pressure gradient behind the detonation wave was positive and the pressure at the exit of the tube could have been as high as 50 ATM.

Now how will the detonation wave behave with this pressure environment behind it as it propagates against the supersonic flow? Initially, when the wave developed, it may have been a strong wave. This has been observed experimentally by Bollinger (1), and discussed by others (6, 16, 17). Thus the wave entered a region of flow with a compression type of environment behind it; therefore it could have remained a strong wave. The only way a detonation wave could have been attenuated would have been for a rarefaction wave to have existed behind the detonation wave. Then in the state of the gas behind a strong detonation wave, the speed of sound would have been greater than that at the Chapman-Jouguet condition. As a result rarefaction waves would have overtaken the detonation wave and eventually attenuated it to the Chapman-Jouguet state. But under the conditions that existed in the supersonic experiments in this study, the environment behind the wave would not have permitted the existence of rarefaction waves. Instead compression waves would have existed behind the detonation wave and would have overtaken the wave front and amplified it or kept it propagating as a strong wave. This phenomenon would have been analogous to a piston which would have compressed the gas behind the wave.

The possibility of the detonation wave being in a continuously quenching and redevelopment stage was considered. But since the observed wave velocities did not vary after the first two probes more than the possible error in the velocity data of ± 150 feet/sec, this explanation could not be correct. But the wave may have entered a condition of partial quenching when it passed through the environment of the transition section. Here it passed through an area increase first and then an area decrease back to the original area of the tube. Also the wave was propagating in static gas which would not have been entirely a combustible mixture of gas and then suddenly was confronted with an oncoming flow of gas. This may have caused the wave to partially quench, but not enough to prevent the ionization probes from firing. In this condition the wave could have been in the state just prior to the Chapman-Jouguet steady condition; i.e., the wave could have been a strong wave. Then as the wave propagated through the tube it would have redeveloped again--similar to the onset from deflagration. In Figures 33 and 34 are schlieren photographs of the wave. The first one was a condition of subsonic flow and the second one of supersonic flow. Both photographs indicate a second disturbance behind the detonation wave. This appeared very similar to a detonation wave that had been photographed by Oppenheim (16) that appeared during the development stage of a detonation wave. These photographs are discussed in greater detail in the next section of this chapter.

Another explanation of this strong wave could have been associated with the "spinning" type of detonation wave. This type of wave is

characterized by oscillations propagating at right angles to the direction of motion of the detonation wave. This condition increases progressively as the limits of detonation are approached in either mixture, initial pressure or tube diameter. The detonation tends to acquire the "spinning mode" and it becomes finally quite unstable, so that its velocity of propagation varies significantly and in some instances by even more than 100% (17). Schlieren photographs of such unstable waves demonstrate that they are associated with an actual separation of the shock wave from the reaction zone, followed by the re-establishment of detonation which is carried out apparently in a manner quite similar to its initial onset from deflagration (16). Again, the schlieren photographs in Figures 33 and 34 may be evidence of this spinning detonation. The mixture in this study was near stoichiometric; therefore, it was not near the detonation limits. The 1 1/2 inch diameter of the FDT may have permitted transverse oscillations. But the initial pressure in the supersonic tests in this study were subatmospheric; therefore, this may have brought about the spinning detonation that could have produced the increased velocities of propagation.

Therefore, it is believed that the strong wave in the supersonic experiments is the result of the particular pressure environment that existed behind the detonation wave as it propagated in the FDT. The high pressure in the burned gas that existed in the transition section (Figure 5) acted as a piston on the detonation wave as it passed this point. The increasing pressure gradient in the burned gases behind the wave prevented attenuation of the wave. The photographic evidence

of detonation waves indicated that the wave may not have been fully developed. The good agreement of supersonic experiment No. S-2-1 listed in Table 4 where the wave traveled with the flow and was not exposed to this particular pressure environment further substantiates these explanations of the strong wave. This departure from the classical Chapman-Jouguet behavior of a detonation wave should not be unexpected. Recent reports by Shchelkin and Troskin (19) indicate irregularities in the classical theory of detonation waves. Also in 1959, Gross reported (8) observations that were characteristic of strong detonation waves as was stated in Chapter I.

Photographic Results of Detonation

The results of the effort to photograph the profile of the detonation wave as it propagated against the oncoming flowing gas are shown in Figures 27 through 34. These eight schlieren photographs were selected from fifteen successful tests. The results although difficult to analyze in detail are considered to be excellent. Approximately seventy tests were made with the optical system installed in the detonation system of which ten were conducted with supersonic flow in the tube; but only fifteen of these experiments resulted in good photographs.

Figures 27 through 30 are schlieren photographs of the detonation wave propagating into a subsonic flow of oncoming gas. The flow conditions are indicated under the photograph. The direction of the flowing gas and the detonation wave are shown in each figure. The

photographs are enlarged to approximately double size. The photographs indicate that the wave front that was visible remained planar throughout the subsonic flows (the highest mass flow rate choked the tube). Therefore the flow of the oncoming gas did not influence the shape of the profile of the wave in the core of the flow. In front of the main disturbance a slight trace of another disturbance appears. This second disturbance increases in intensity and size as the mass flow rate increases and the distance between the two disturbances also increases with the mass flow rate. This disturbance is the result of the detonation wave near the wall propagating into the boundary layer and ahead of the core of the wave.

Then, in Figures 31 and 32 are shown schlieren photographs of the detonation wave propagating into a supersonic flow of oncoming gas. Details of flow conditions and directions are included in the figures. Figure 31 is the Mach 3 nozzle with $M = 2.79$ in the viewing section and Figure 32 is the Mach 4 nozzle with $M = 3.85$ in the viewing section. The Mach numbers in the viewing section are actual values that were determined from artificial Mach lines photographed with the schlieren system. The profile of the Mach 3 wave front did not appear to be affected by the oncoming flow but the profile of the Mach 4 wave is curved in the direction of the oncoming flow. The velocity profile of the oncoming flow definitely influenced the front of the detonation wave. In both photographs the disturbance that appears in front of the wave was greater than in the subsonic results. The distance between the disturbances is about the same. Here again

this disturbance in front of the wave is a result of the wave propagating into the boundary layer.

There was no doubt that the disturbances in front of the wave were in the boundary layer. They appeared in the photograph because the detonation wave is three dimensional; the light from the spark light was deflected by that part of the detonation wave that had propagated ahead into the boundary layer that was next to the windows of the viewing section. The disturbances are the result of the combustion in the boundary layer and the interaction of the detonation wave with the boundary layer. They are stronger in the Mach 4 wave probably because of the small disturbances that were already in the supersonic flow. Photographs of reflected shock waves in shock tubes reveal similar disturbances ahead of the shock.

In all the photographs with the exception of the Mach 4 wave the disturbances behind the wave front appear as parallel striations that are perpendicular to the wave front. Similar types of disturbances have been observed by Morrison (14) and Oppenheim (17) for detonation waves propagating in a static mixture of gas. Morrison explains the striations in the vicinity of the front as non-homogeneity of the gas in this region. He also stated that this non-homogeneity seems to penetrate into the front itself, which has a globular appearance. The photographs from this study indicated similar characteristics. Oppenheim refers to these striations as a result of turbulence or if the wave were in a spinning mode he interprets them as manifestations of tridimensional oscillations that are sustained by the transverse waves. The striations are not caused by luminous foreign particles

in the gas because, if this were true, the striations would appear across the entire photograph.

In a recent book by Shchelkin and Troskin (19) on detonation studies conducted in Russia it was reported that in practically all cases the detonation wave front is unstable and a planar detonation has probably never occurred, and the number of recorded cases of nonplanar detonation waves has increased as the resolving power of the photographic equipment was improved. Also, that the flame front is a three-dimensional structure and the wave is a pulsating detonation. As a result of this current research in Russia, the striations are probably the result of the variation of pressure and temperature in the transverse waves that are due to the pulsation of the detonation front. It should be noted that these striations decay a very short distance behind the wave front.

Figures 33 and 34 are photographs which revealed a third disturbance some distance behind the detonation wave. Figure 33 is a subsonic flow of about 950 feet/sec and Figure 34 is with the Mach 3 nozzle. As is discussed in this chapter under the supersonic flow results, it is believed that this is a retonation wave that is propagating in the opposite direction from the detonation wave. The data on the velocity of these experiments indicate that the wave is propagating with a steady velocity prior to reaching the viewing section. The curvature of these waves indicated they are traveling downstream. There is evidence in the photograph of further disturbances downstream of these disturbances. If this were a retonation wave, this additional disturbance is characteristic of such waves. A retonation

wave is brought about by an explosion that most probably occurs in a pocket of unburned gas that is formed in the boundary layer as a result of partial quenching of the gas or as a result of the detonation wave being in a state just prior to the fully developed stage. This explanation is further supported by evidence of a small disturbance in Figure 34, between the detonation wave and the retonation wave, that extends from the upper surface of the tube into the flow. A similar disturbance is much more noticeable in Figure 32 of the Mach 4 wave.

CHAPTER VII

CONCLUSIONS

The conclusions about the behavior of a detonation wave in a flowing combustible gas are based on the analysis of the results of this study.

The theoretical portion of this study revealed many interesting aspects of the parameters of the detonation wave as it propagated into the flowing gas. This fact is especially true for the theoretical analysis of the supersonic flow. As a result of the expansion of the gas in order to achieve supersonic flow in the tube the detonation wave propagated into low temperatures and subatmospheric pressures but the density remained fairly constant; thus the theoretical absolute Chapman-Jouguet velocity of the wave did not vary much. But the Mach number approximately doubled which resulted in a large increase in the temperature and pressure gradients in the front of the wave. Also as a result of the increasing pressure along the axis of the tube as the supersonic flow decelerated toward the exit, an environment with an increasing pressure gradient existed behind the detonation wave instead of a constant or decreasing pressure gradient that is necessary in order to achieve the Chapman-Jouguet steady condition. Thus, theoretically, the wave could exist as a strong wave.

It is believed that the experimental portion of this study deals with a condition of detonation heretofore not studied. A detonation wave was propagated not only in high subsonic flows but also in supersonic flows up to Mach 4. The subsonic experiments were generally in agreement with the theoretical predictions, but the supersonic experiments disclosed that the detonation wave could not behave as was predicted by the Chapman-Jouguet theory, but propagated as a strong wave; i.e., the absolute detonation wave velocity was greater than the absolute Chapman-Jouguet steady velocity. In both the subsonic and supersonic experiments the relative wave velocity that was measured between probes did not vary in such a manner to indicate that the wave was unsteady. Thus from the experiments it was concluded that the detonation wave did propagate in the flowing gas in a steady condition, but in the supersonic flow the wave was a strong wave because of the particular pressure environment that existed in the tube.

The photographing of the detonation wave in this environment of a flowing gas with low temperatures and pressures revealed interesting results. The flowing gas appeared to have no effect on the planar front of the wave except at the wall in the subsonic experiments, but in the Mach 4 experiments the front of the detonation wave was influenced by the profile of the velocity in the unburned gas. This effect on the profile of the wave was the result expected from the profile of a fully developed turbulent flow in a tube. Photographic evidence of a possible detonation wave indicated wave instability even though the velocity appeared to be steady.

Although not a planned part of this study, the results of the accidental detonations indicated that a detonation wave would propagate with the stream for both a subsonic or supersonic flow. Just how the accidental detonation waves developed without normal ignition in the supersonic stream is open to speculation.

In summary, it is believed that this study has initiated a new area of research on detonation waves. The experimental observations of wave velocities and photographs reveal evidence that the wave is steady but is affected by the flow. The supersonic experiments further support the evidence of the existence of strong detonation waves under certain conditions. This type of research will lead to a better understanding of the behavior of detonation waves that may see purposeful applications to supersonic combustion and understanding of combustion instability.

APPENDIX I

THEORETICAL CALCULATIONS

APPENDIX I

THEORETICAL CALCULATIONS

In order to have a basis with which to compare the experimental results, theoretical calculations of the detonation parameters were made.

The Fanno theory was used to compute the temperature and pressure profile along the axis of the tube. The calculations were carried out using the working formulas obtained by Shapiro (18). Thus, the initial pressures and temperatures that appear in Table 1 and Figures 17 and 18 were obtained. The average friction factor that was used was obtained from the experimental calibration of the tube. It was found to be 0.006 for the subsonic flows and was estimated to be 0.003 for the supersonic flows. This was in agreement with the studies of Keenan and Neumann (11).

The Hugoniot equation and the Chapman-Jouguet theory were used to calculate the detonation wave parameters as the wave propagated into the constantly changing flow conditions. These calculations were carried out with a computer program that was written in the Fortran language that was used on an IBM 1620 computer at the AFIT School of Engineering (5). The computer program was written to solve the Hugoniot equation and the Chapman-Jouguet state was determined by finding the minimum value of the detonation velocity. The

calculations were based on the assumptions that the mixture was comprised of ideal gas constituents and that the wave process was governed by equilibrium end conditions. The thermochemical data were obtained from the JANAF tables. The parameters that described the state of the detonation wave immediately behind the wave front were obtained from the normal shock tables (18). The heat added to the process was obtained from the Hugoniot equation assuming an average specific heat and molecular weight. The results of these theoretical calculations are presented in Table 1 that is included in this appendix.

TABLE 1

THEORETICAL DETONATION WAVE PARAMETERS FOR
SUPERSONIC FLOW OF MACH 1 TO 4

$M_{u,1}$	P_1 (ATM)	T_1 (°K)	P_b (ATM)	T_b (°K)	$\frac{P_b}{P_1}$	$\frac{T_b}{T_1}$	$W_{D,1}$ ft/sec	$M_{D,1}$	$M_{D,2}$	$\frac{P_2}{P_1}$	$\frac{m_b}{m_1}$	$\frac{\rho_b}{\rho_1}$	$\frac{q_{m1}}{RT_1}$	q kcal/gm
1.0	1.000	250	22.39	3705	22.39	14.82	9379	5.78	0.406	38.81	1.212	1.83	42.4	1.56
1.5	0.646	206	17.88	3662	27.66	17.78	9350	6.32	0.402	46.43	1.209	1.88	53.5	1.56
2.0	0.408	167	13.50	3605	33.07	21.59	9329	6.94	0.398	56.02	1.207	1.85	64.8	1.53
2.5	0.293	135	12.12	3535	41.45	26.56	9324	7.64	0.394	67.93	1.204	1.88	82.5	1.53
3.0	0.218	107	11.34	3570	51.91	33.36	9328	8.50	0.391	84.13	1.205	1.88	104.4	1.48
3.5	0.150	85.0	10.60	3560	70.80	41.85	9320	9.35	0.389	101.8	1.203	1.89	130.5	1.51
4.0	0.133	71.5	10.34	3550	77.56	49.65	9327	10.27	0.387	122.9	1.205	1.88	158.2	1.45

APPENDIX II

EXPERIMENTAL RESULTS (DATA TABLES)

TABLE 2
 SUBSONIC TEST DATA FOR A DETONATION WAVE
 PROPAGATING IN A FLOWING STOICHIOMETRIC
 MIXTURE OF HYDROGEN - OXYGEN

Exp No	\dot{m}_t lb _m /sec	r	$W_{D,1}$ (ABS-TH) feet/sec	u_1 feet/sec	$W_{D,1}$ (REL-TH) feet/sec	$W_{D,1}$ (REL-EXP) feet/sec	$M_{u,1}$
A-1	0.099	6.42	9950	272	9678	9660	0.14
B-1	0.172	7.65	9380	395	8985	8950	0.22
C-4	0.213	7.82	9370	474	8896	8820	0.27
D-1	0.259	7.98	9300	583	8717	8780	0.34
E-1	0.301	8.04	9280	647	8633	8700	0.37
F-3	0.346	8.07	9270	742	8528	8570	0.43
G-6	0.386	8.26	9230	800	8430	8500	0.47
H-3	0.436	8.12	9280	860	8420	8430	0.50
I-4	0.484	8.25	9240	920	8410	8330	0.54
J-1	0.530	8.12	9280	943	8337	8300	0.55
K-2	0.590	8.08	9270	972	8298	8320	0.57
L-2	0.713	8.11	9280	1173	8107	8150	0.66

TABLE 3
RELATIVE VELOCITIES OF THE DETONATION WAVE
BETWEEN IONIZATION PROBES FOR SUBSONIC FLOWS^a

Exp No	A-1	B-7	C-4	D-1	E-1	F-3	G-6	H-3	I-4	J-1	K-2	L-2
2	9620	--	--	--	--	--	8450	8400	--	--	8380	7570
3	9770	--	--	--	--	8650	--	--	8570	--	8620	8120
4	9620	--	8880	--	--	8620	8450	8510	8540	8250	8620	8310
5	-- ^b	8900	9100	--	--	--	8620	8670	--	8120	8670	8100
6	--	--	8830	8820	8770	8590	8430	8380	8330	8200	8450	8270
7	--	8880	--	--	9140	8820	8820	8700	8770	8670	8550	8170
8	9660	--	9010	8870	8670	8770	8470	8560	8350	8580	8670	8130
9	9430	8970	8880	8820	8770	8620	8470	8380	8330	8570	8570	8770
10	9620	--	8880	9010	8820	8700	8800	9180	8700	8650	8670	8150
11	9670	8830	--	8820	8750	8670	8650	8480	8380	8220	8450	0 ^c
12	--	--	--	8960	8620	8700	8470	8980	--	--	8290	0
13	9520	8830	8900	8720	8950	8970	8560	8900	--	--	8360	0
14	9670	8830	8880	9090	9180	8820	8520	8380	8490	8420	8700	0
15	9620	--	9100	9030	8960	8750	8580	8330	9020	8350	8570	0
16	--	8920	--	8820	9080	--	9120	8660	8330	--	8700	0
17	9820	8880	8880	8680	8820	--	8820	8820	8330	8600	8650	0
18												
AVE	9660	8950	8920	8860	8840	8700	8600	8600	8460	8400	8500	8150

^aDistance between probes 4.000 inches except probes 8-9 → 6.497 inches and probes 13-14 → 7.426 inches. (Velocities in feet/sec)

^bDash indicates probes did not fire.

^cCircle indicates no probes in this position for this experiment.

TABLE 4
 SUPERSONIC TEST DATA FOR A DETONATION WAVE
 PROPAGATING IN A FLOWING STOICHIOMETRIC
 MIXTURE OF HYDROGEN - OXYGEN

Exp No	Pc psia	\dot{m}_t lb _m /sec	r	W _{D,1} (ABS-TH) feet/sec	u ₁ feet/sec	W _{D,1} (REL-TH) feet/sec	W _{D,1} (REL-EXP) feet/sec	M _{u,1}
S-2-1	45.0	0.873	8.43	9180	2300	11,840	11,475	1.53
S-2-2	45.0	0.885	8.03	9320	2300	7020	7430	1.53
S-2-3	45.0	0.905	8.52	9270	2300	6970	7080	1.53
S-2-4	47.3	0.858	7.75	9375	2300	7025	7180	1.53
S-2-5	47.3	0.847	7.62	9470	2300	7170	7410	1.53
S-2-6	45.3	0.852	7.80	9380	2300	7080	7050	1.53
S-3-1	144.3	0.828	7.94	9350	2700	6650	7180	2.05
S-3-2	144.3	0.831	7.78	9270	2700	6570	7270	2.05
S-3-3	144.3	0.829	7.95	9330	2700	6630	7240	2.05
S-3-4	144.3	0.827	7.96	9300	2700	6600	7170	2.05
S-4-4	350.0	0.806	7.75	9400	3300	6100	7560	2.83
S-4-5	350.0	0.809	7.94	9300	3300	6000	7480	2.83
S-4-6	350.0	0.811	7.85	9380	3300	6080	7500	2.83

TABLE 5
RELATIVE VELOCITIES OF THE DETONATION WAVE BETWEEN
IONIZATION PROBES FOR SUPERSONIC FLOWS^a

Exp No	S-2-1	S-2-2	S-2-3	S-2-4	S-2-5	S-2-6	S-3-1	S-3-2	S-3-3	S-3-4	S-4-4	S-4-5	S-4-6
2	--b	7560	7210	7370	7540	6980	7560	8220	7500	7700	7820	7600	7840
3	11,600	7370	7010	7130	7150	7190	7380	7700	7400	7020	7570	7600	8000
4	11,350	7360	7020	6990	7540	6970	7070	6870	7070	7190	7570	7320	7350
5	0 ^c	0	0	0	0	0	7170	7140	7140	7170	7510	7530	7410
6	0	0	0	0	0	0	7190	7020	7190	7230	7230	7370	7130
7	0	0	0	0	0	0	6970	7280	7290	7080	7600	7330	7460
8	0	0	0	0	0	0	7020	7020	7290	7160	7650	7540	7440
9	0	0	0	0	0	0	7040	6940	7070	7020	7500	7550	7390
10													
AVG	11,475	7430	7080	7180	7410	7050	7180	7270	7240	7170	7560	7480	7500

^aDistance between probes 4.000 inches except probes 5-6 → 7.496 inches.

^bDash indicates probes did not fire. (Velocities in feet/sec)

^cCircle indicates no probes in this position for this experiment.

APPENDIX III

DATA REDUCTION CALCULATIONS

APPENDIX III

DATA REDUCTION CALCULATIONS

The experimental data obtained in this study had to be reduced in order to compare it with the theoretical predictions. The calculations that were involved are presented in this appendix.

Mass flows

The raw data for determination of the mass flow rates for each experiment were recorded on the oscillograph as described in Chapter II. These data were the pressure, differential-pressure and temperature for each venturi meter in the hydrogen and oxygen feed systems. The individual mass flow rates were calculated from the equation (12)

$$\dot{m} = 0.525 Y_a C_d \frac{d^2}{(1 - B^4)^{1/2}} (\rho \Delta P)^{1/2} \quad (1)$$

where

d = venturi throat diameter = 0.376 inches

$B = \frac{\text{venturi throat diameter}}{\text{venturi inlet diameter}} = 0.575$

C_d = discharge coefficient = 0.984

Y_a = compressibility correction factor

ρ = inlet density (lb_m/sec)

ΔP = differential pressure (psi)

\dot{m} = mass flow rate (lb_m/sec)

Introducing a reference temperature of 100°F and

$$Y_a = \left(1 - 0.644 \frac{\Delta F}{P}\right) \quad (\text{Reference 12})$$

and

$$\rho = \frac{Pm}{RT}$$

the mass flow equation becomes:

$$\dot{m}_H = 0.00149 \left(1 - 0.644 \frac{\Delta P_H}{P_H}\right) \left(P_H \Delta P_H \frac{560}{T_H}\right)^{1/2} \quad (2)$$

and

$$\dot{m}_O = 0.00565 \left(1 - 0.644 \frac{\Delta P_O}{P_O}\right) \left(P_O \Delta P_O \frac{560}{T_O}\right)^{1/2} \quad (3)$$

Average flow velocity

The average flow velocity in the flowing-gas detonation tube was computed from the continuity equation for the subsonic flow and from the Mach number and the speed of sound for the supersonic flow.

For subsonic flow

$$\dot{m}_T = \dot{m}_O + \dot{m}_H = \rho_{ave} A u_1(ave) \quad (4)$$

Solving for the average flow velocity

$$u_1(ave) = \frac{\dot{m}_T}{\rho_{ave} A} \quad (5)$$

From the perfect gas law

$$\rho_{ave} = \frac{P_{ave} m}{R T_{ave}} \quad (6)$$

the average flow velocity of the unburned gases becomes

$$u_1(\text{ave}) = \frac{\dot{m}_T R T_{\text{ave}}}{P_{\text{ave}} m_1 A} \quad (7)$$

where

R = universal gas constant

m_1 = molecular weight of unburned gases

P_{ave} = average pressure for the particular mass flow condition in the FDT

T_{ave} = average temperature for the particular mass flow condition as determined from Fanno theory in the FDT

A = area of flowing-gas detonation tube

Then the average Mach number of the subsonic flow was

$$M_{u,1} = \frac{u_1(\text{ave})}{a} \quad (8)$$

where "a" is obtained as stated below for supersonic flow.

For the supersonic flow

$$u_1(\text{ave}) = a M_{u,1}$$

where

M = Mach number of unburned gases as determined from the Fanno theory

$$a = \left[\gamma \frac{R}{m} T_{\text{ave}} \right]^{1/2}$$

and where

γ = ratio of specific heats at T_{ave}

R, m, T_{ave} = same as defined for subsonic flow

Relative velocity of detonation wave

The relative velocity of the detonation wave which is the velocity of the wave with respect to the tube is defined theoretically as the difference between the theoretical absolute Chapman-Jouguet steady velocity and the average flow velocity of the unburned gases:

$$W_{D,1}(\text{REL-TH}) = W_{D,1}(\text{ABS-TH}) - u_1(\text{ave}) \quad (11)$$

and the experimental relative velocity is determined from

$$W_{D,1}(\text{REL-EXP}) = \frac{s}{t} \quad (12)$$

where

s = distance between ionization probes

t = time for passage of wave between probes

The distance was determined from the physical measurement between the centerline of the probes. This measurement is accurate to ± 0.001 inches. The time is determined from the oscilloscope photograph. This time is accurate to $\pm 1/2$ microsecond. Thus, the absolute detonation velocity is believed to be accurate to ± 150 feet/sec.

APPENDIX IV

OPERATION OF DETONATION SYSTEM

APPENDIX IV

OPERATION OF DETONATION SYSTEM

Since a large portion of this study was concerned with the design, construction, and checkout of the apparatus and the instrumentation, a discussion is given of the overall performance and operation of the detonation system. In general, the detonation system and its associated instrumentation performed quite satisfactorily. The only major difficulty encountered was the occasional accidental detonation of the FDT without normal ignition. As stated in Chapter V, this problem did not prevent the achievement of the experiments that were planned. After a thorough investigation of all possible factors that could have caused the accidental detonation, it is believed that the only possible factor could have been some oil in the air that was used to purge the FDT. But, the facility at the Aerospace Research Laboratories at Wright Field where the high pressure air was obtained probably has one of the best air purifier and dehumidifier systems of any such facility in the country.

The propagation of the detonation wave from the IDT into the FDT through the transition section was very successful. But, since the flowing combustible gas exited from the FDT at the transition section into the exhaust duct prior to detonation, a fire ball would appear at this point when the wave passed through the transition section.

This condition resulted in damage to the light aluminum door on the exhaust duct that provided entrance to the transition section for the replacement of the mylar diaphragm for each experiment. The door was replaced with a 3/16 inch stainless steel curved plate (material similar to the exhaust duct) with a 4 inch by 8 inch entrance instead of the 12 inch by 12 inch door. This smaller hole was covered with a piece of mylar prior to each experiment. It would contain the flow through the exhaust duct prior to detonation but it would rupture upon detonation; thus, it also served as a pressure relief valve.

The exhaust duct carried the combustible gas to the outside of the building and exited them to the atmosphere. Prior to detonation, air was dumped into the exhaust to dilute the gas. The exhaust duct was the part of the design that, if possible, in future work with this apparatus should be eliminated. The main reason was that it took a lot of air to dilute the combustible mixture of gas to a point where no burning or only slow burning took place in the duct. Also, there was a mixing problem; i.e., regardless of the method of directing the air into the duct, there could always be a core of rich combustible gas that was not diluted. Therefore, consideration should be given to the direct exhaust to the atmosphere of the combustible gas prior to detonation. This could be accomplished very simply with the IDT portion of the detonation system installed outside the test cell.

The ionization probes, detector output circuit and oscilloscope with raster performed satisfactorily overall, but the ionization probes required considerable attention. As stated in Chapter III the

early design of the probes was modified. Since the tip of the electrode of the probe was exposed to the interior of the FDT, the high temperatures and high pressures encountered during an experiment gradually destroyed the insulation of the electrode. The modified design was a great improvement over the early design. Since the probe was a very critical component in the measurement of the velocity of the detonation waves, further study should be conducted on it. For this reason, the author of this dissertation suggested an investigation of probes for the measurement of velocity of detonation waves. Such an investigation is presently being conducted by an AFIT graduate student under the supervision of the author.

The purge and shutdown system had to be modified. At first, the purge and shutdown system was activated at the same moment that the ignition switch was turned on to fire the IDT. The experiments were good and data were obtained, but the shutdown of the flow of hydrogen and oxygen was not fast enough. As a result combustion continued for several milliseconds in the stagnation chamber that was upstream of the FDT. In order to correct this condition, the air purge was modified to enter the stagnation chamber directly instead of through the hydrogen and oxygen feed lines. This improved the shutdown sequence. Also, the thermocouple installed in the stagnation chamber acted as a backup for automatic shutdown at the completion of each experiment. It performed very satisfactorily.

The gas supply and control system had the usual problems of any such system. The Grove regulators had to be repaired frequently. A supply of spare parts was obtained and necessary repairs could be

made. If high-pressure filters could have been installed in the feed lines between the regulators and the source of gas, most of the malfunctions would have been eliminated. Also, it was found that pressures above 1500 psi at the source would not give smooth flow through the system. Therefore, it was suggested that each feed line should have two regulators in series, one to regulate the pressure to some intermediate level and then the second one to the pressure that was desired for the particular experiment. Transducers, which had been mounted on a rack with the feed lines, had to be completely isolated from all other components in order to eliminate any mechanical input. The Atkomatic automatic solenoid valves that were used in the feed lines were a source of trouble until a pin in the main valve piston was modified.

REFERENCES

REFERENCES

1. Bollinger, L.E. Formation of Detonation Waves in Hydrogen - Oxygen Mixtures from 0.2 to 2 Atmospheres Initial Pressure in a 54 - Meter Long Tube. NASA Technical Note No. D-2256. Washington: National Aeronautics and Space Administration, 1964.
2. Bollinger, L.E. "Formation of Detonation Waves in Combustible Gaseous Mixtures" (Paper presented at the Western States Section Meeting of the Combustion Institute), Paper No. WSS/CI 64-15, Stanford University (April 1964).
3. Bollinger, L.E., Fong, M.C., and Edse, R. "Experimental Measurements and Theoretical Analysis of Detonation Induction Distances". ARS Journal (May 1961), 588-595.
4. Bollinger, L.E., et al. High-Speed Photographic Investigation of the Formation of Detonation Waves in a Stoichiometric Hydrogen - Oxygen Mixture. NASA Technical Note No. (None presently assigned, prepared under Grant NsG-44-60.) Washington: National Aeronautics and Space Administration, 1963.
5. Bowman, G.P. Computer Program for Calculating Detonation Wave Parameters for Hydrogen - Oxygen - Nitrogen Mixtures. Unpublished notes. Air Force Institute of Technology (AU), Wright-Patterson Air Force Base, Ohio, 1965.
6. Dunn, R.G. Detonation in High-Pressure Hydrocarbon-Oxygen Mixtures. Ph.D. dissertation, Ohio State University, Columbus, Ohio, 1964.
7. Gaydon, A.G. and Hurle, I.R. The Shock Tube in High-Temperature Chemical Physics. New York: Reinhold Publishing Corp., 1963.
8. Gross, R.A. Exploratory Studies of Combustion in Supersonic Flow. AFOSR TN 59587, ASTIA AD 216769. Fairchild Engine Division, Fairchild Engine and Airplane Corporation, Deer Park, New York, June 1959.
9. Haars, N.W. A Viewing Section for a Flowing-Gas Detonation Tube. Unpublished thesis. Air Force Institute of Technology (AU), Wright-Patterson Air Force Base, Ohio, 1966.

REFERENCES (contd.)

10. Hunt, James C. An Investigation of the Influence of a Flow Field on Detonation Wave Characteristics in a Stoichiometric Hydrogen - Oxygen Mixture. Unpublished thesis. Air Force Institute of Technology (AU), Wright-Patterson Air Force Base, Ohio, 1959.
11. Keenan, J.H. and Neumann, E.P. "Measurements of Friction in a Pipe for Subsonic and Supersonic Flow of Air," Jour. App. Mech., 13-2 (1946), A-91.
12. Keller, R.G., et al. Operations Manual for the Rocket Engine Test Facility of the Department of Mechanical Engineering. Air Force Institute of Technology (AU), Wright-Patterson Air Force Base, Ohio, August 1961.
13. Lewis, B. and von Elbe, G. Combustion Flames and Explosions in Gases. 2d ed. New York: Academic Press, Inc., 1961.
14. Morrison, R.B., A Shock-Tube Investigation of Detonation Combustion. Engineering Research Institute, UMM-97, University of Michigan, Ann Arbor, Michigan, 1955.
15. Nicholls, J.A., et al. An Experimental and Theoretical Study of Stationary Gaseous Detonation Waves. AFOSR-1764, ASTIA AD 268927. The University of Michigan, Ann Arbor, Michigan, October 1961.
16. Oppenheim, A.K., Laderman, A.J., and Urtiew, P.A. "The Onset of Retonation." Combustion and Flame, 6-3 (1962), 193-197.
17. Oppenheim, A.K., Manson, N., and Wagner, H. Gg. "Recent Progress in Detonation Research," AIAA Journal, 1 (October 1963), 2243-52.
18. Shapiro, A.H. The Dynamics and Thermodynamics of Compressible Fluid Flow. (Volume 1) New York: The Ronald Press Company, 1953.
19. Shchelkin, K.I. and Troshin, K. Ya. Gasdynamics of Combustion. Moscow (in Russian). English translation, same title. Baltimore: Mono Book Corp., 1965.
20. Wolfson, B.T. The Effect of Additives on the Mechanism of Detonation in Gaseous Systems. Ph.D. dissertation, Ohio State University, Columbus, Ohio, 1963.
21. Zeldovich, Y.B. and Kompaneets, A.S. Theory of Detonation. Moscow, 1955 (in Russian). English translation, same title. New York: Academic Press, Inc., 1960.

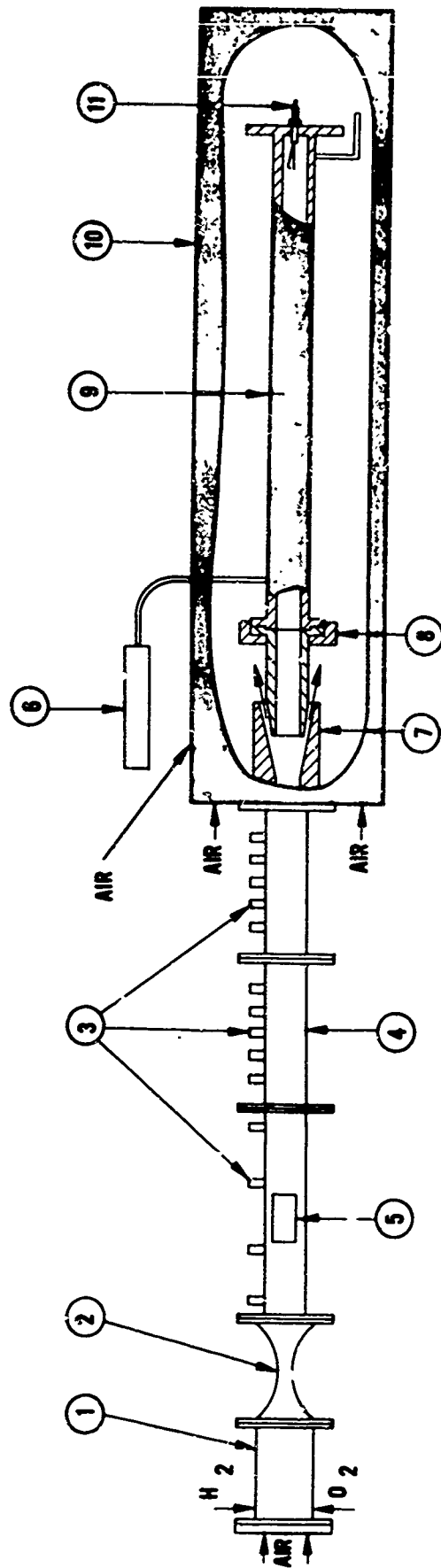

LEGEND

- | | |
|--------------------------------------|-------------------------------------|
| 1. STAGNATION CHAMBER | 6. MIXING CHAMBER |
| 2. NOZZLE | 7. TRANSITION SECTION |
| 3. IONIZATION PROBES | 8. DIAPHRAM ASSEMBLY |
| 4. FLOWING GAS DETONATION TUBE (FGT) | 9. INITIATION DETONATION TUBE (IDT) |
| 5. VIEWING SECTION | 10. EXHAUST DUCT |
| | 11. IGNITION ASSEMBLY |

Figure 1 Schematic Diagram of the Detonation System

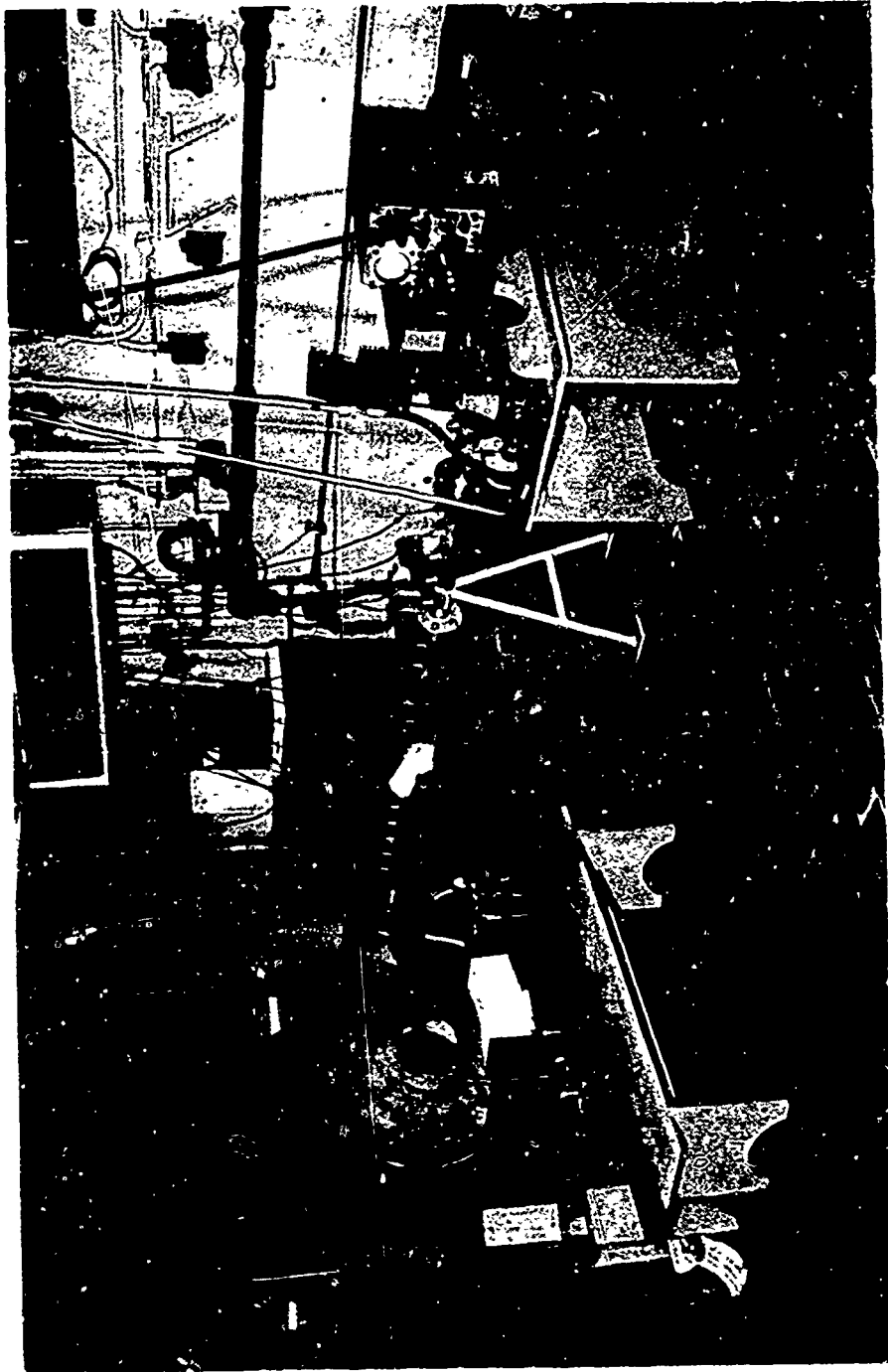

Figure 2 Overall Picture of the Detonation System

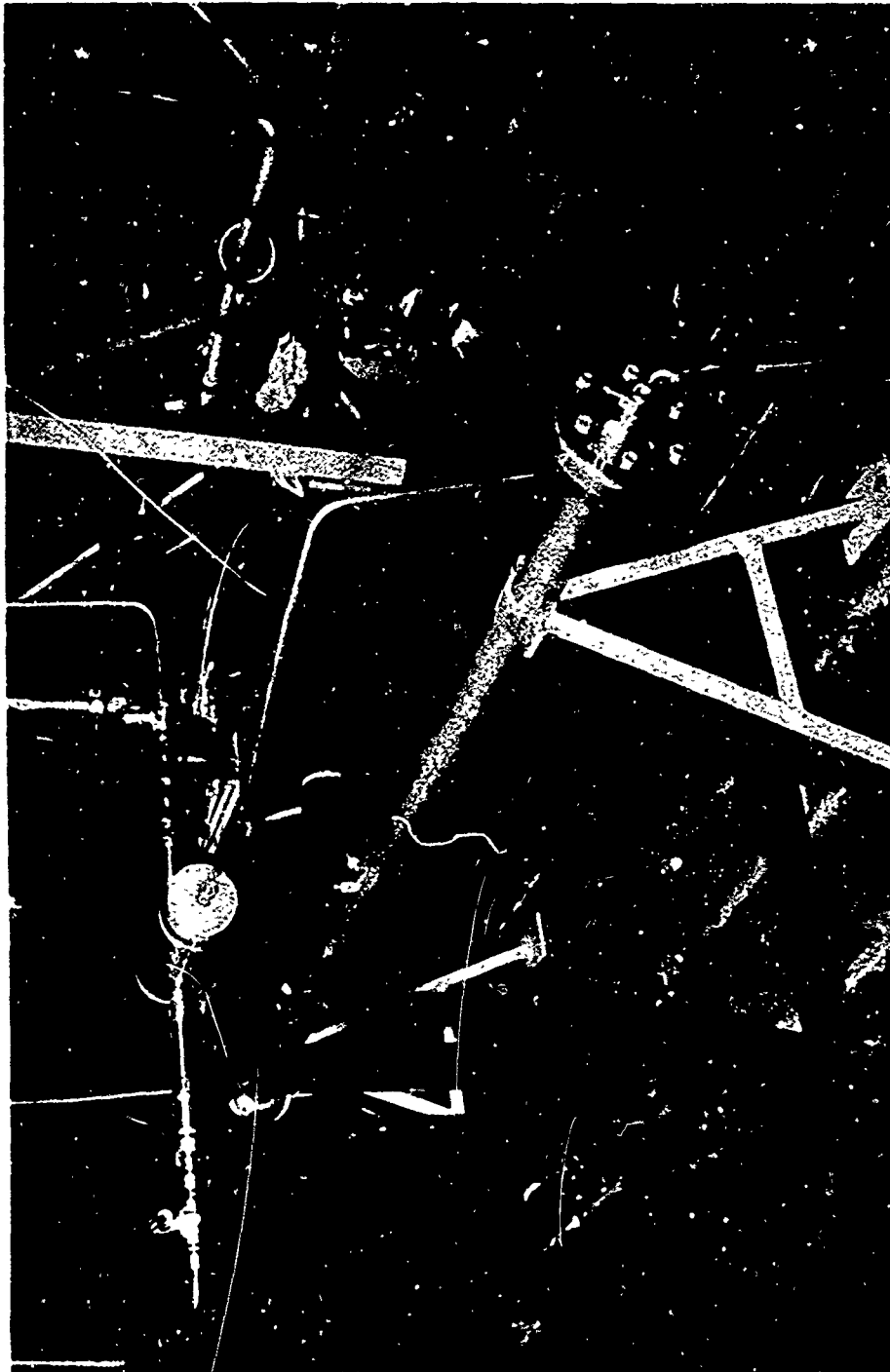

Figure 3 The Initiation Detonation Tube and Mixing Chamber

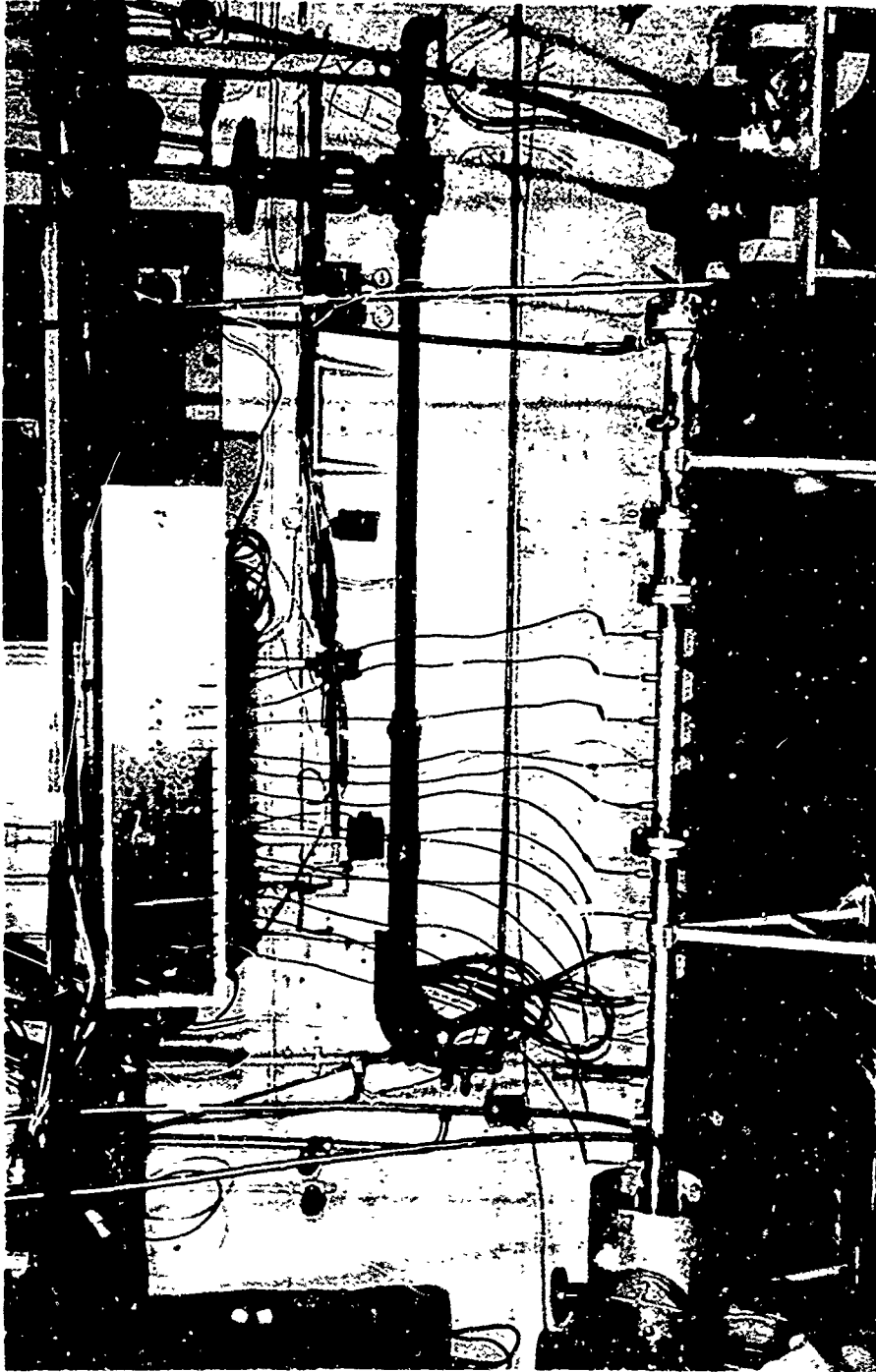

Figure 4 The Flowing-Gas Detonation Tube

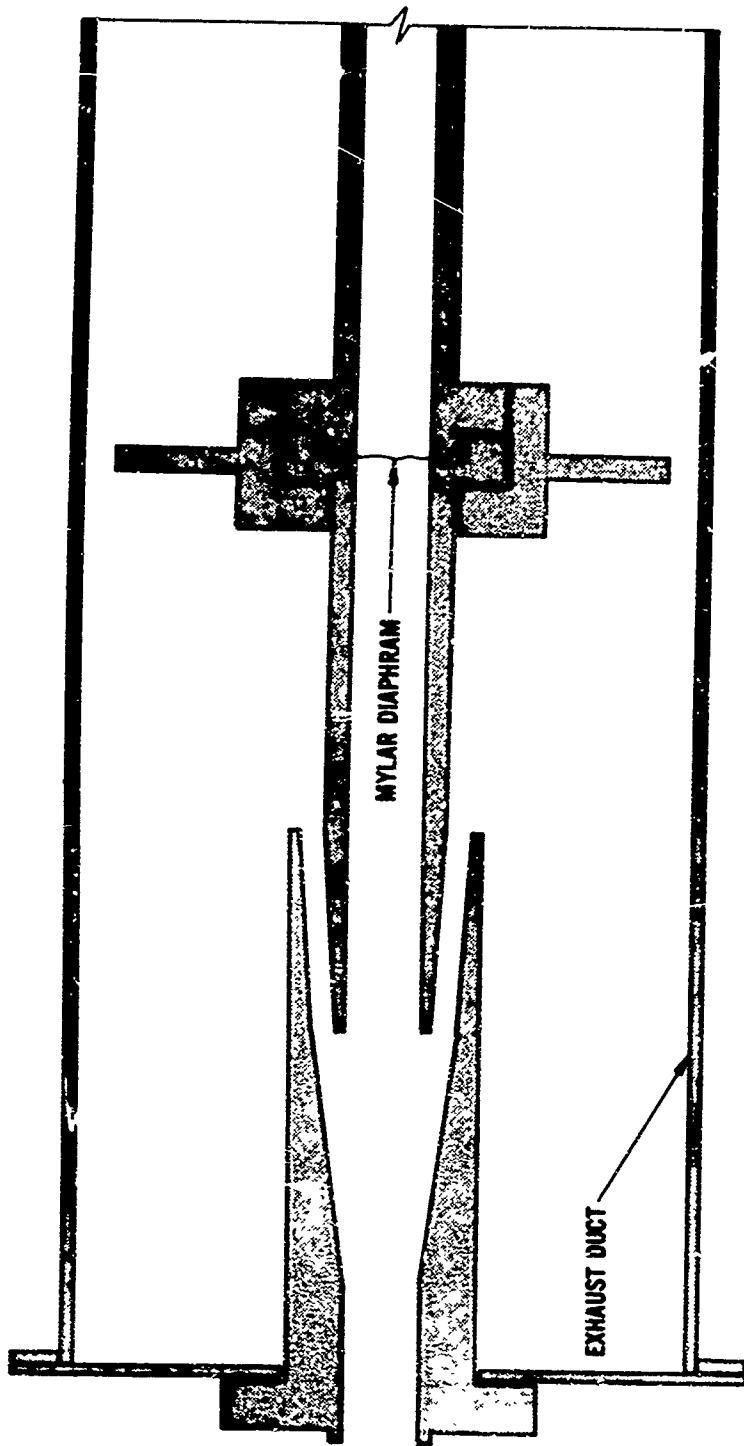

Figure 5 Transition Section and Diaphragm Section in the Exhaust Duct

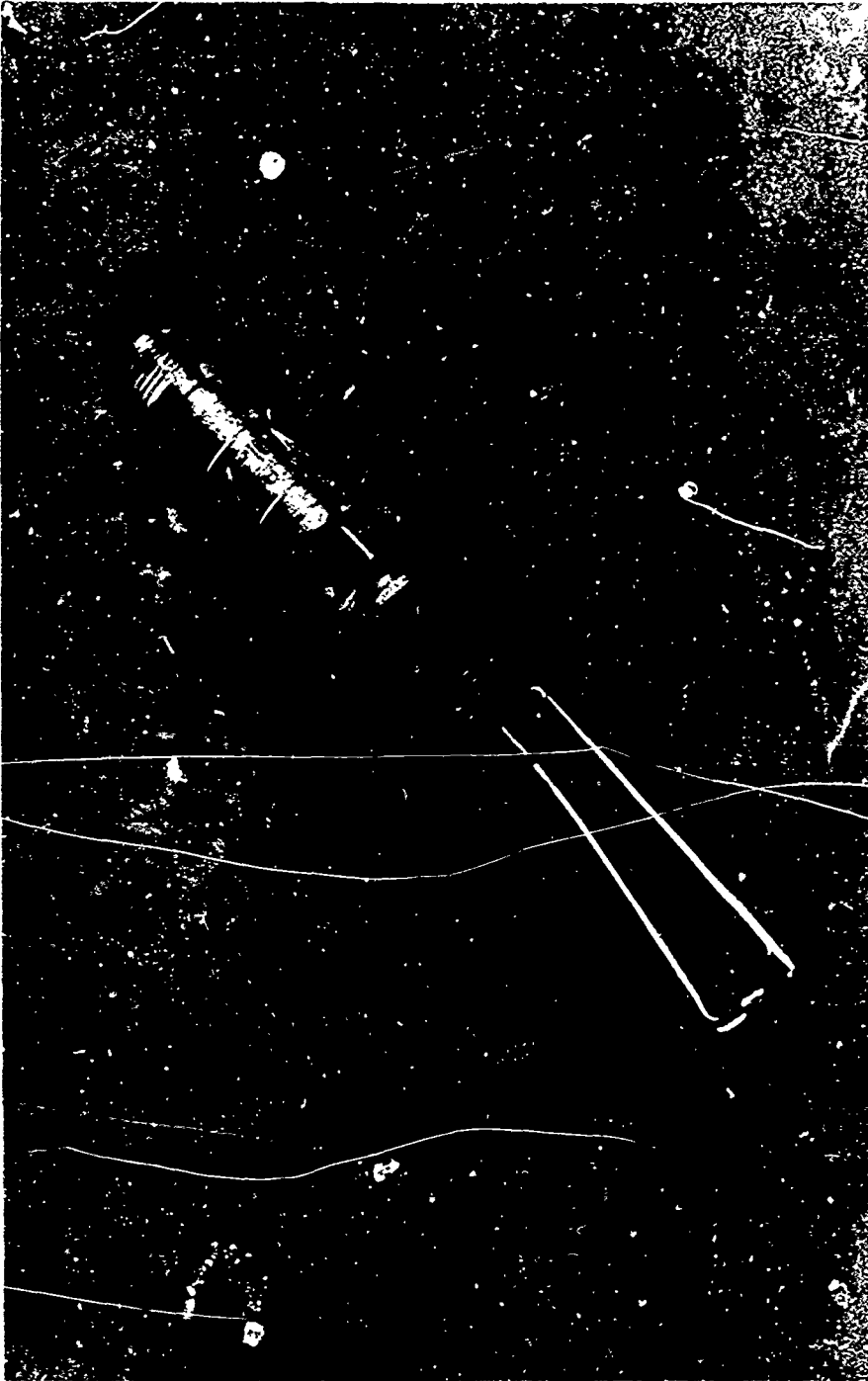

Figure 6 The Modified Ignition Source

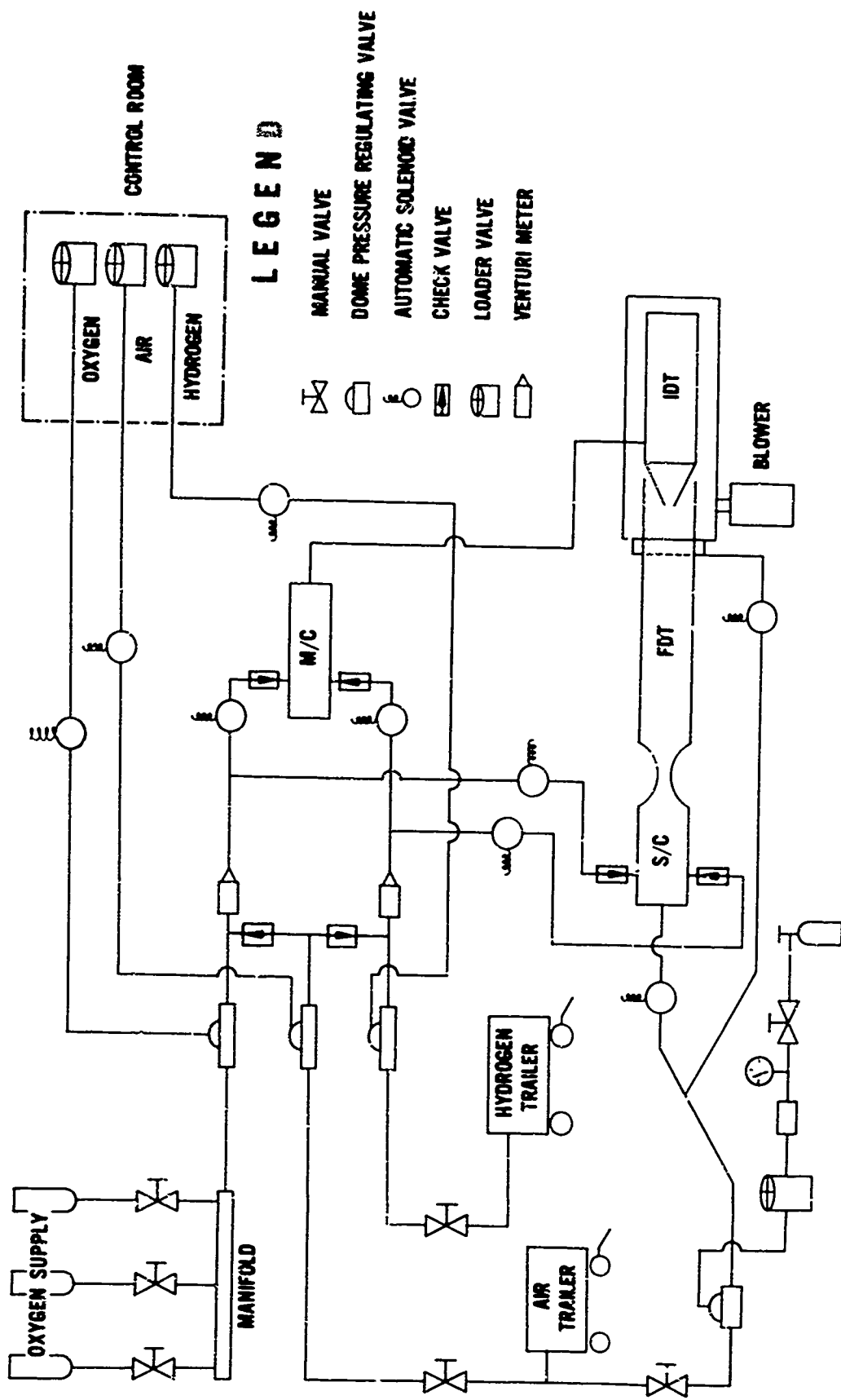

Figure 7 The Gas Supply and Control System for the Detonation System

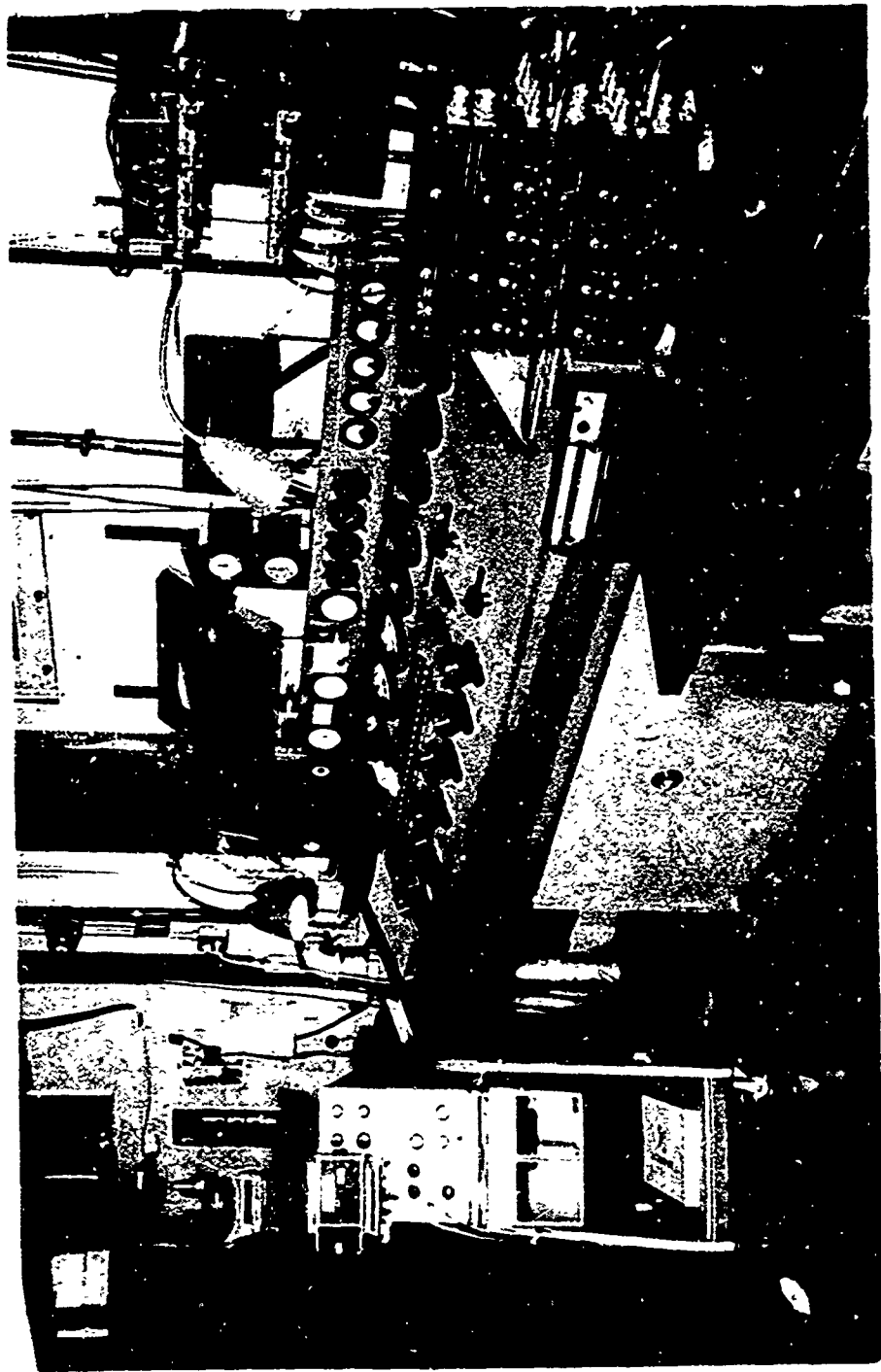

Figure 8 The Control Room and Instrumentation

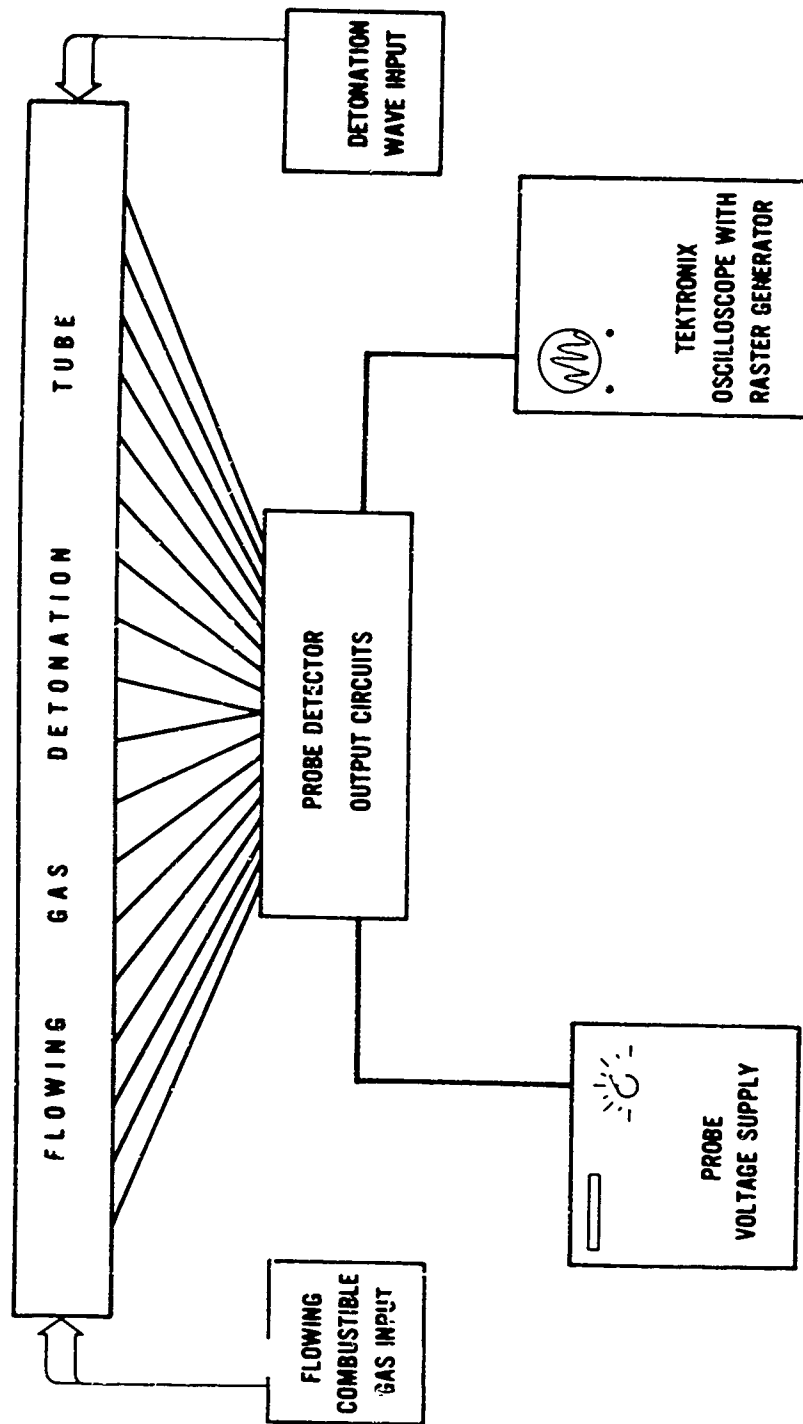

Figure 9 Schematic Diagram of the Instrumentation System

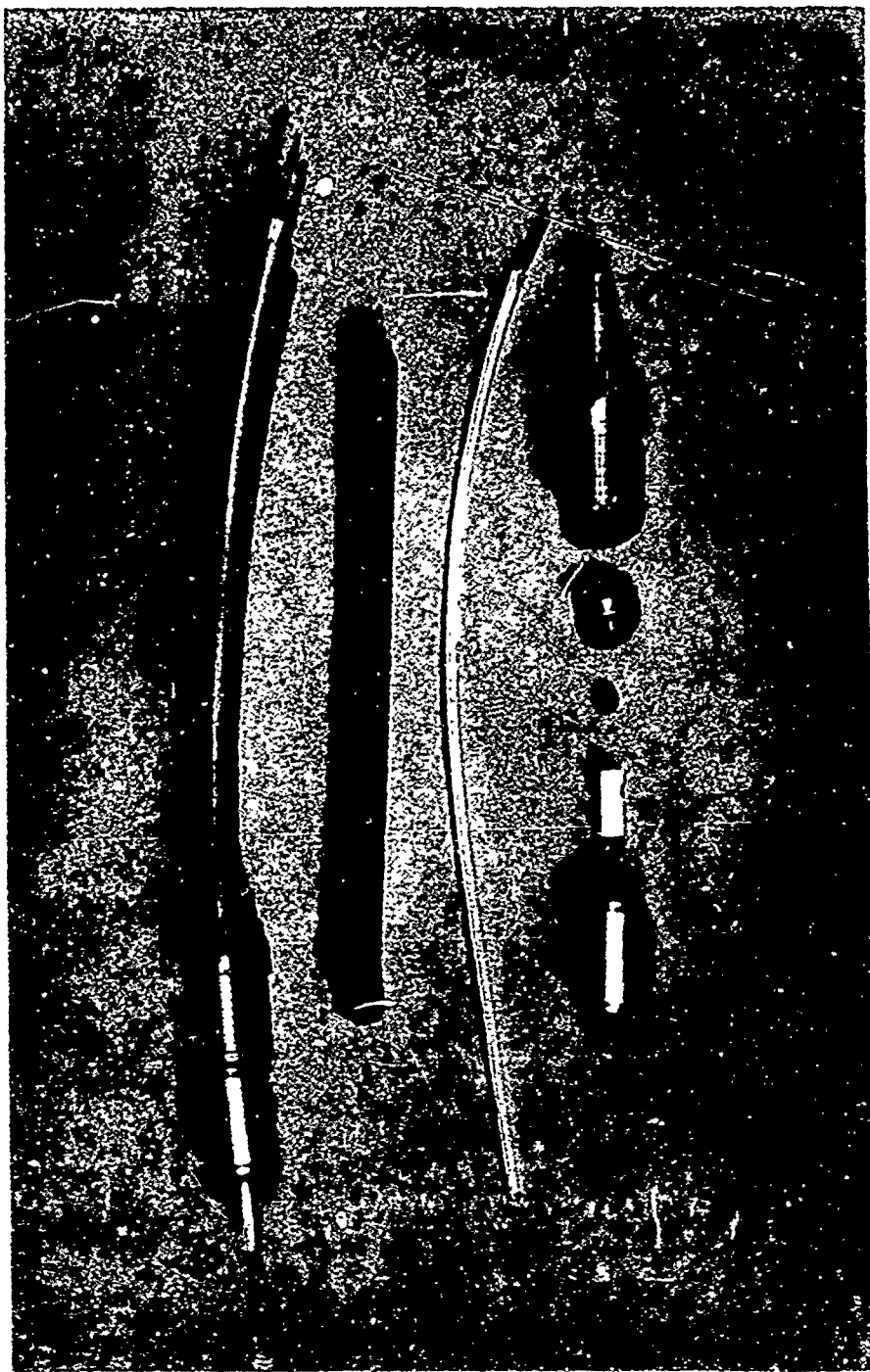

Figure 10 The Ionization Probe and Boss

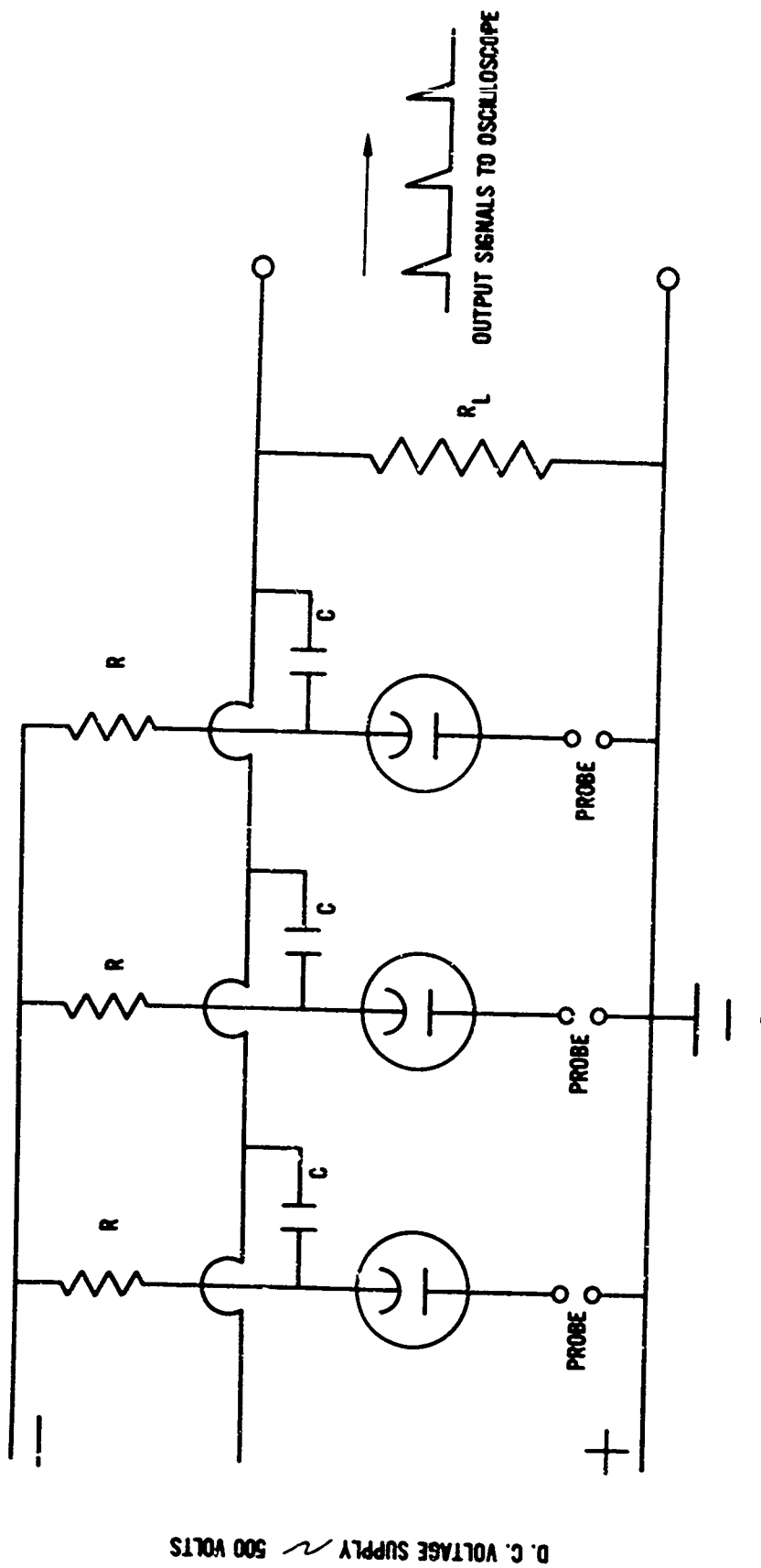

Figure 11 Electrical Circuit for the Ionization Probes

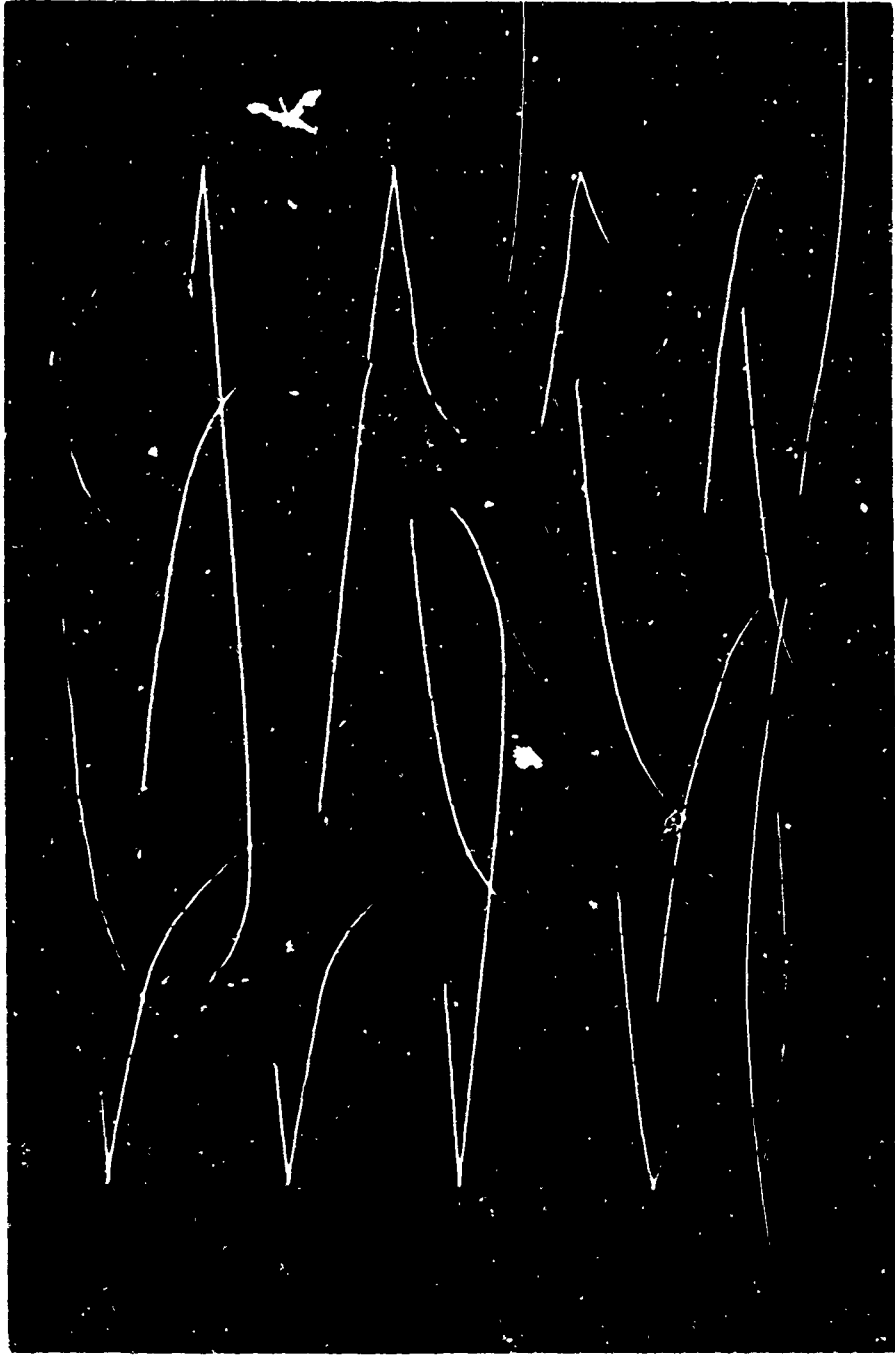

Figure 12 The Typical Oscilloscope Photograph

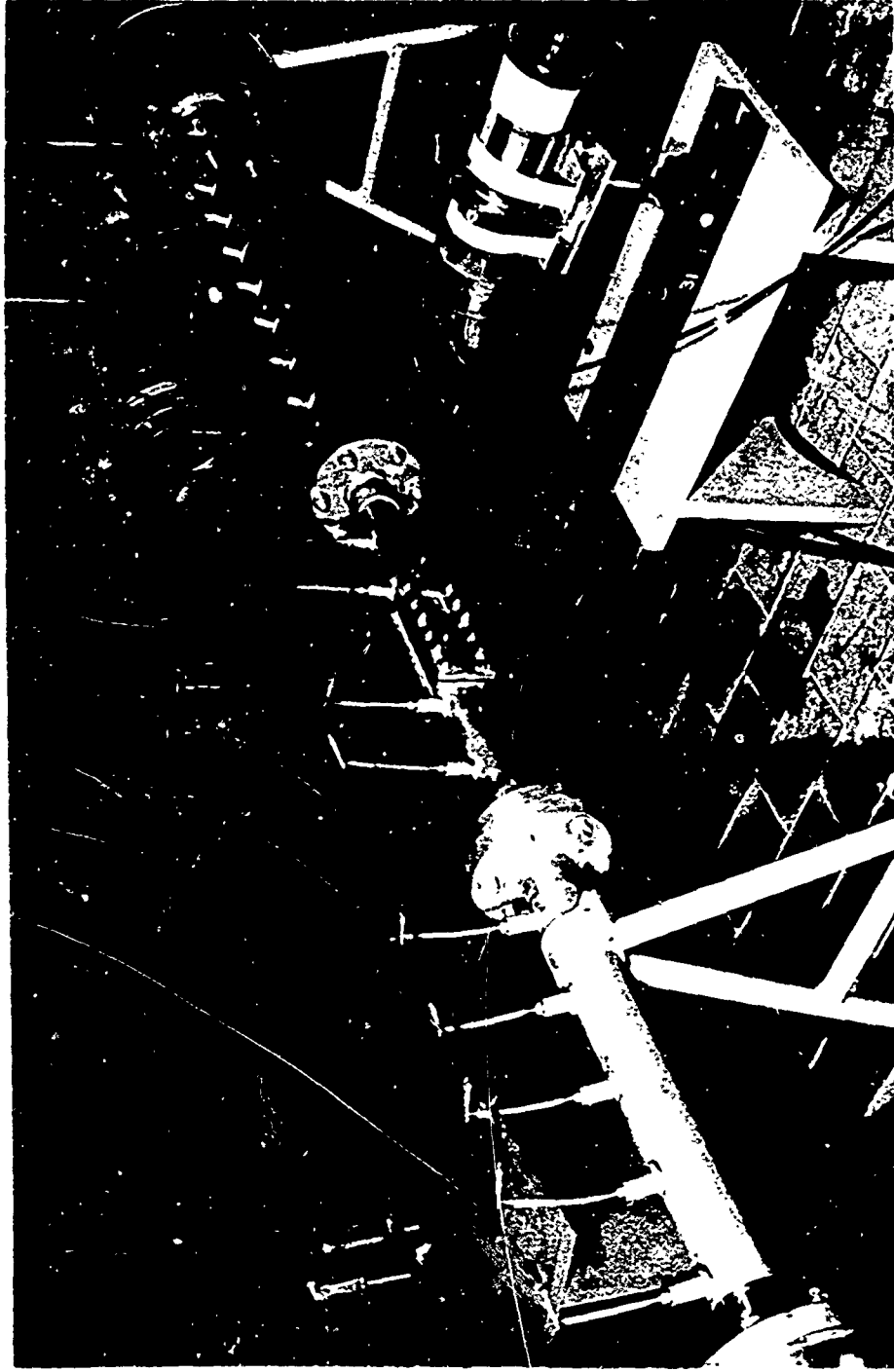

Figure 13 The Optical System Installed in the Flowing-Gas Detonation Tube

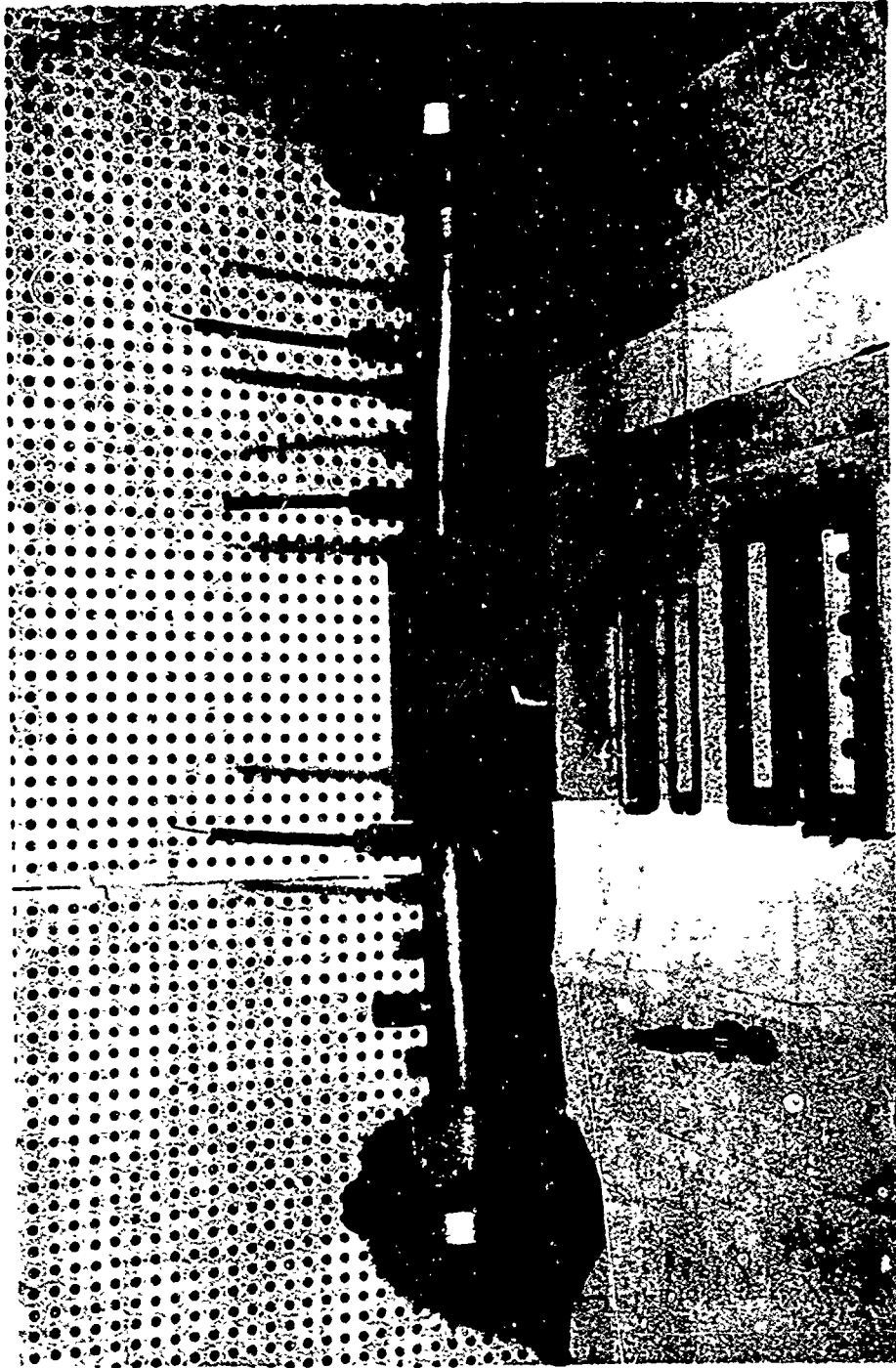

Figure 14 The Viewing Section of the Optical System

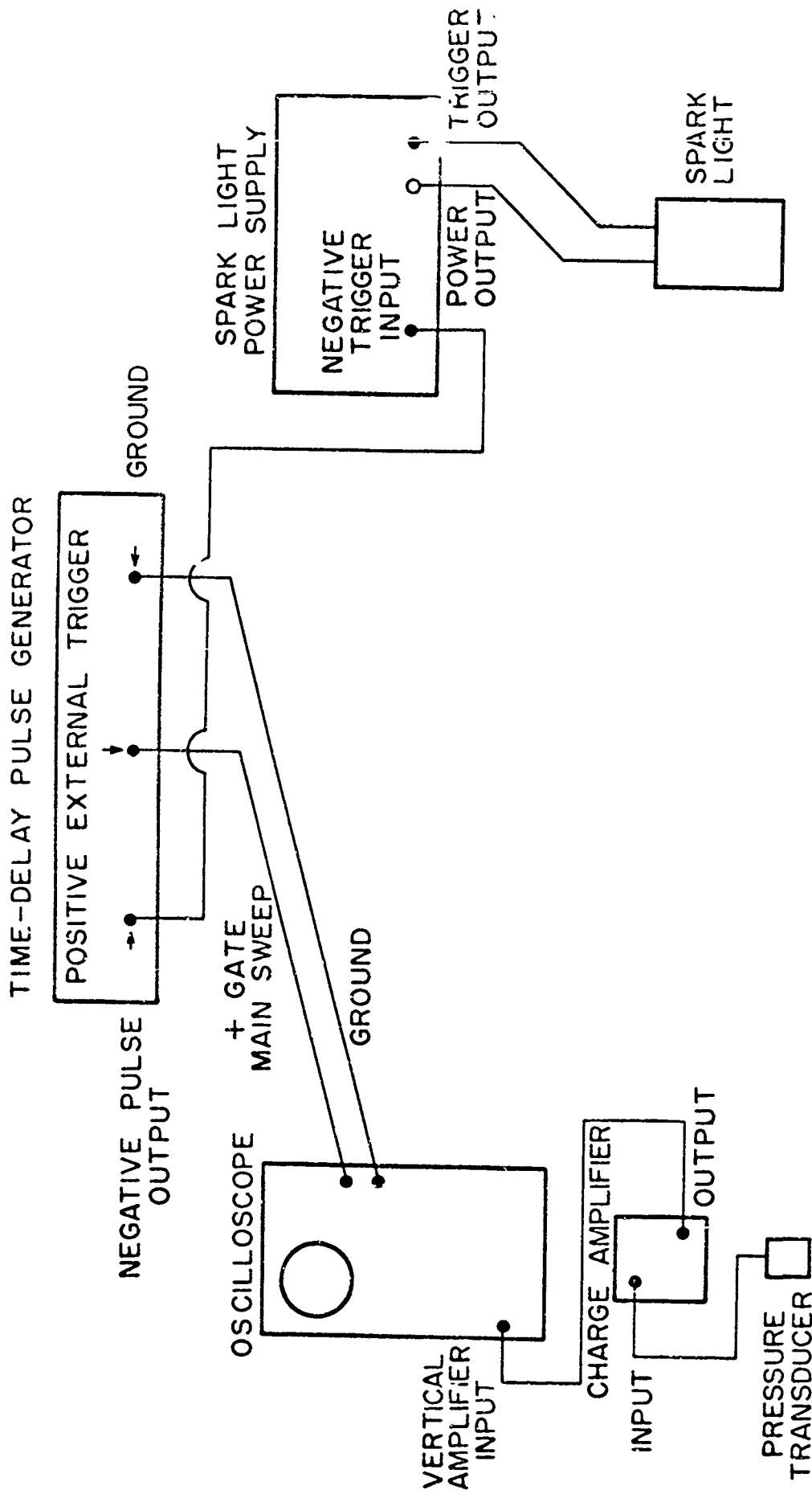

Figure 15 A Schematic Diagram of the Spark Light and Synchronization System

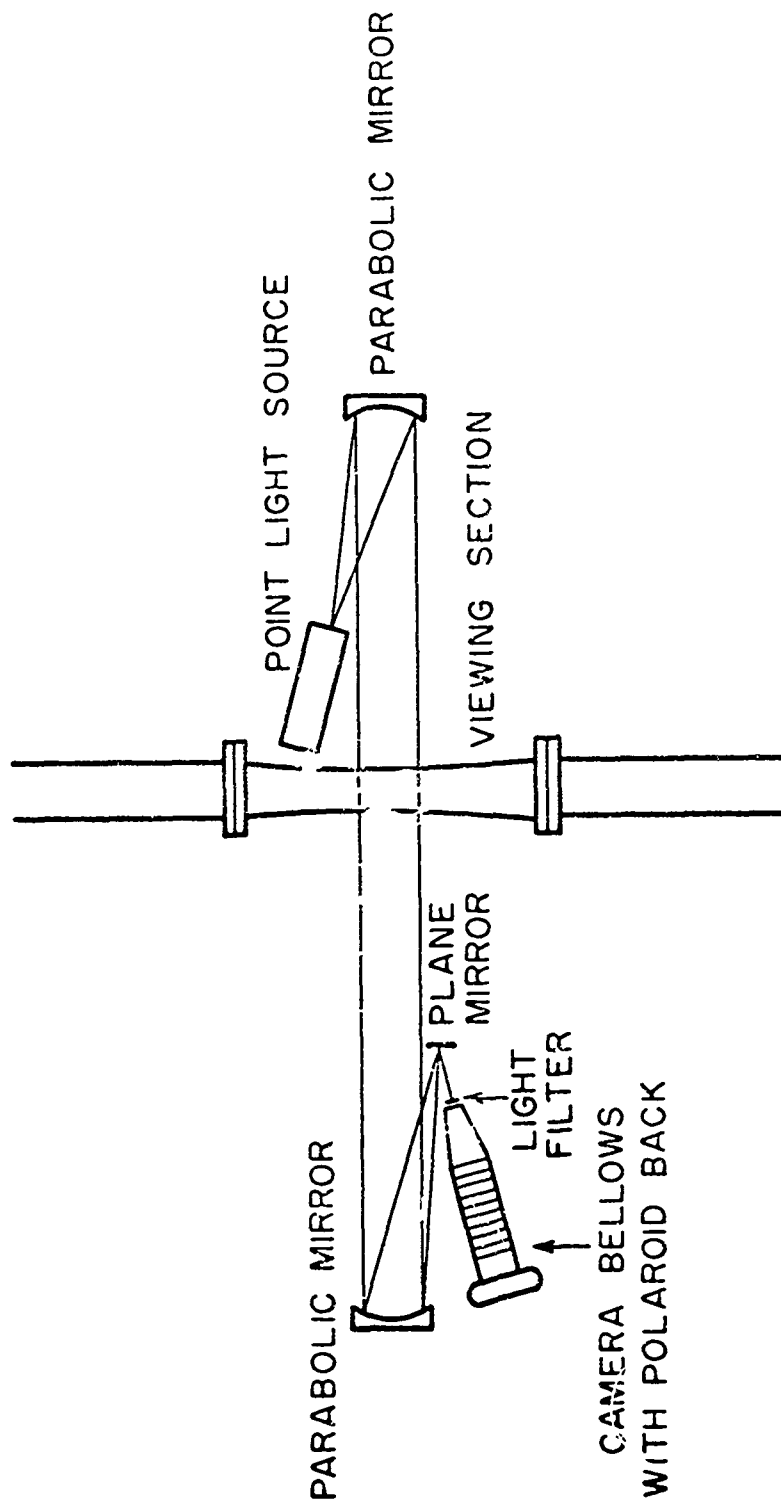

Figure 16 A Schematic Diagram of the Modified Toepler Schlieren System

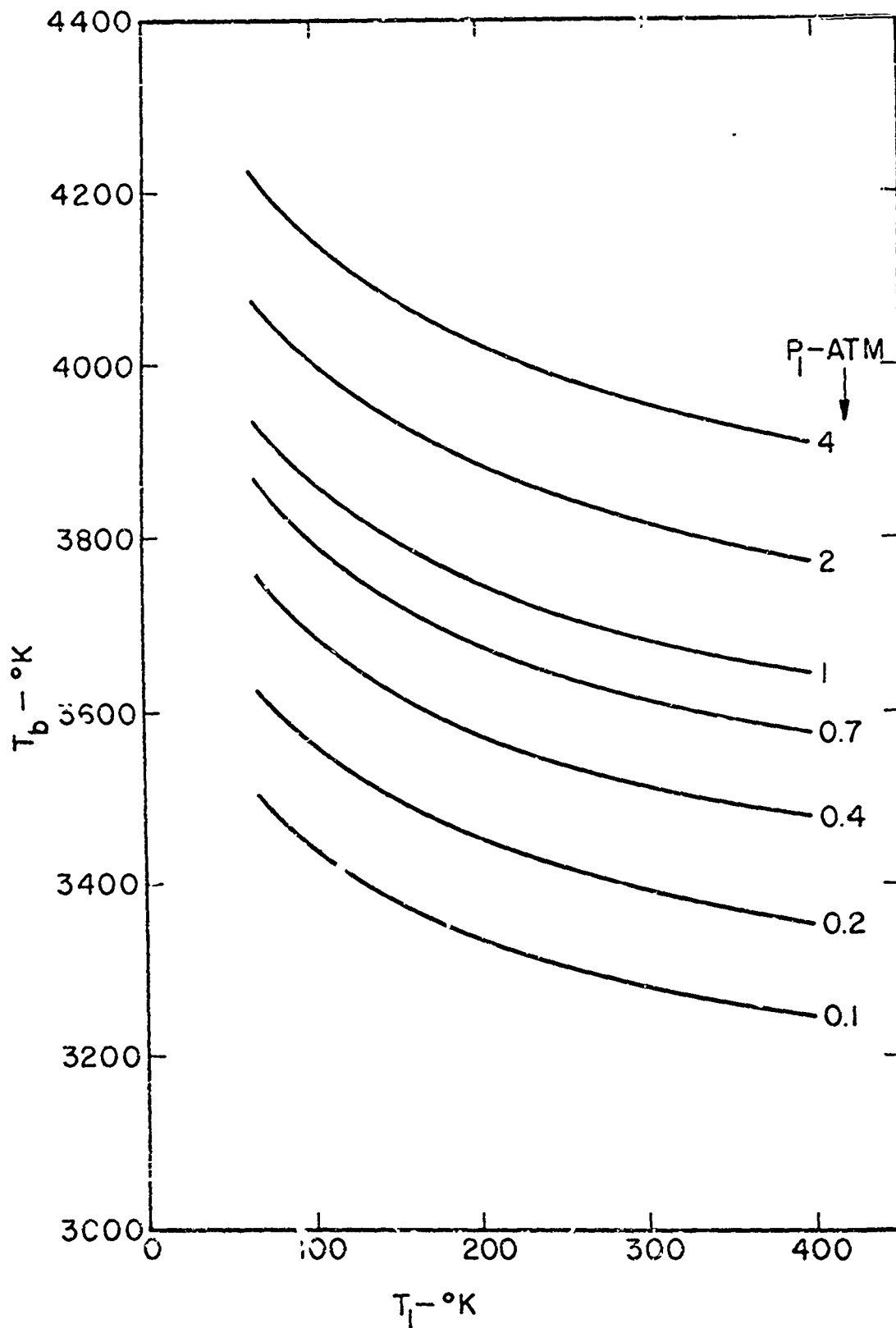

Figure 17 The Theoretical Variations of Final Temperature with Initial Temperature at Constant Initial Pressure for a Stoichiometric Mixture of Hydrogen-Oxygen

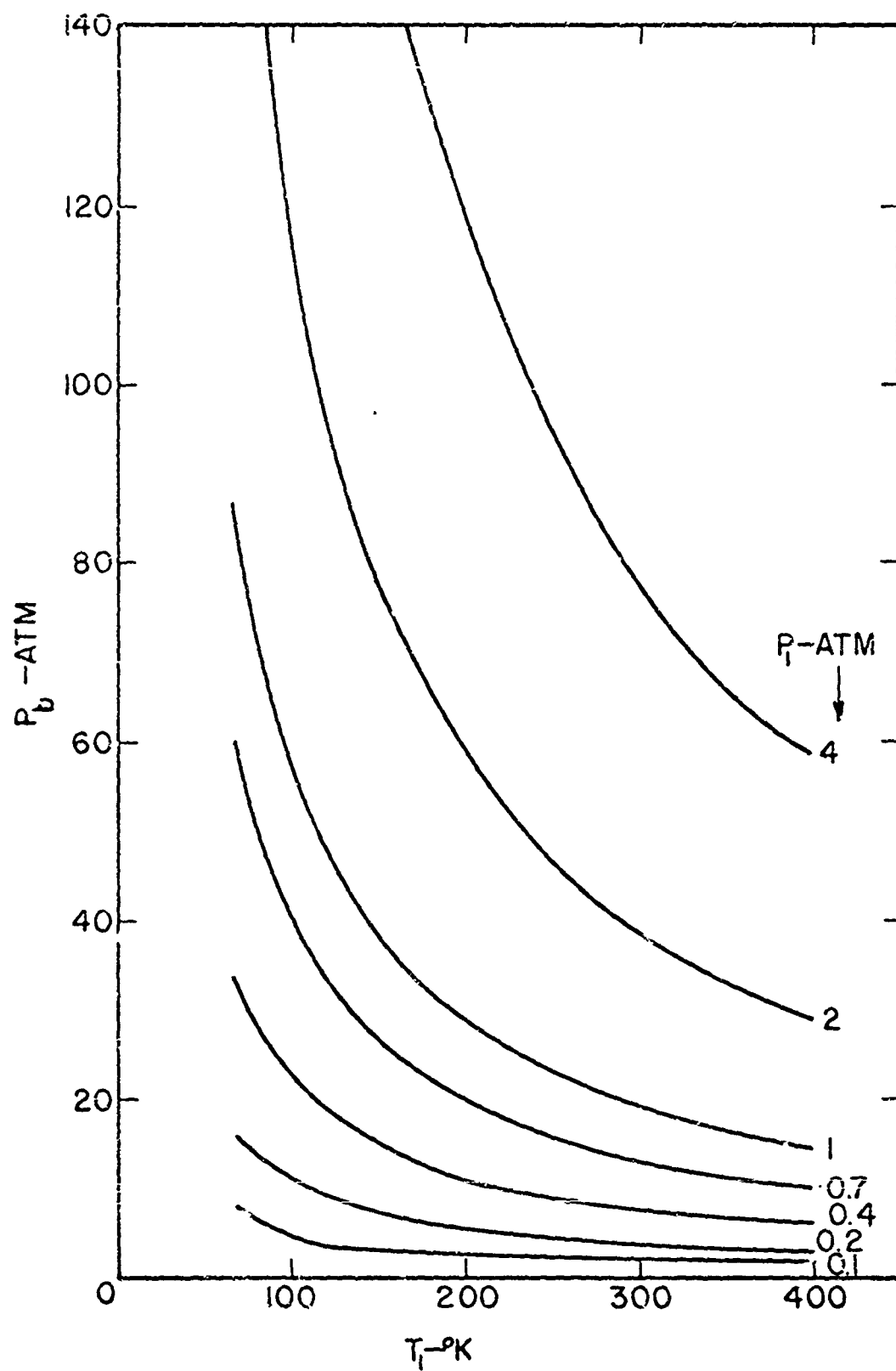

Figure 18 The Theoretical Variations of Final Pressure with Initial Temperature at Constant Initial Pressure for a Stoichiometric Mixture of Hydrogen-Oxygen

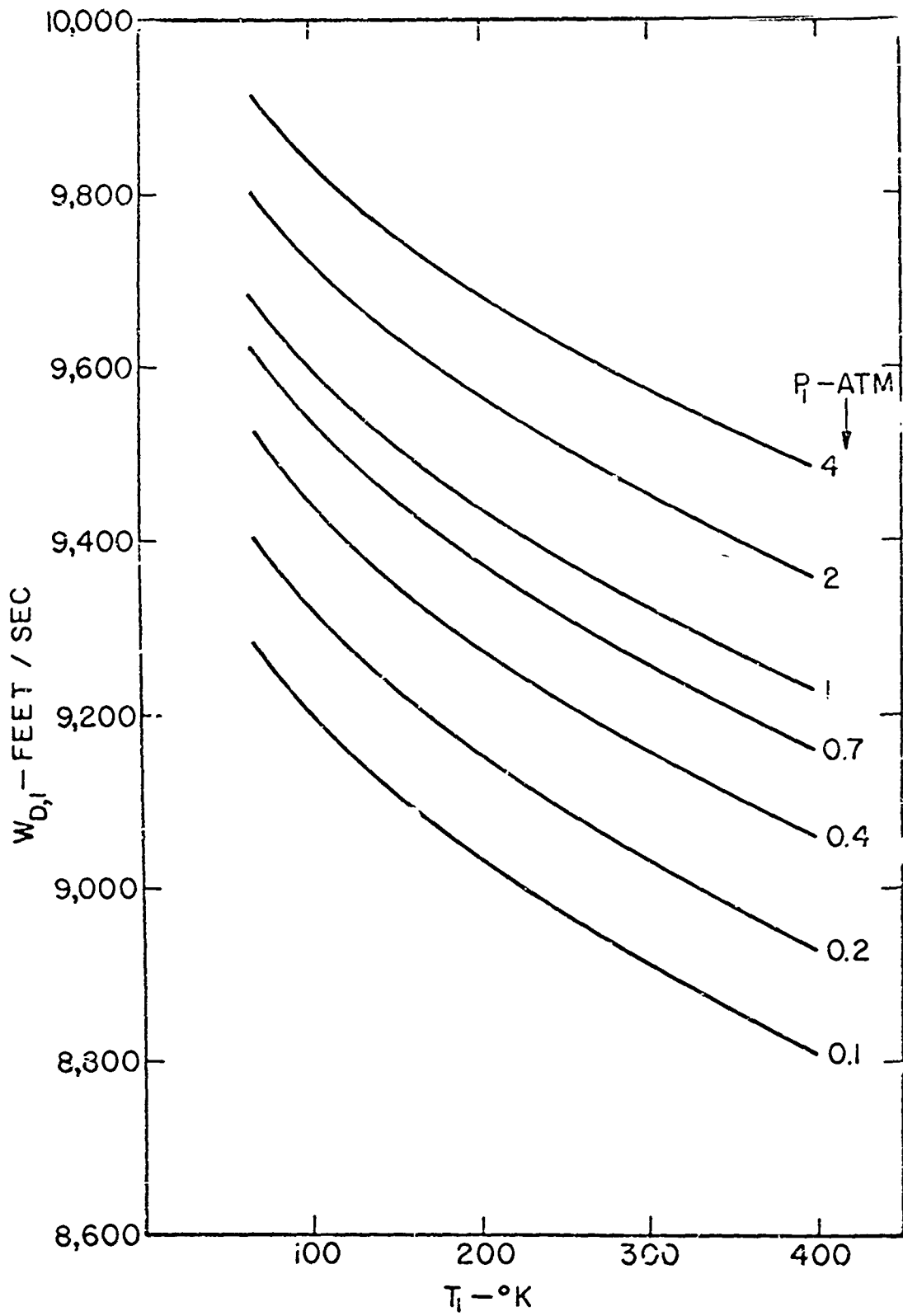

Figure 19 The Theoretical Variations of the Absolute Chapman-Jouguet Detonation Wave Velocity with Initial Temperatures at Constant Initial Pressures for a Stoichiometric Mixture of Hydrogen-Oxygen

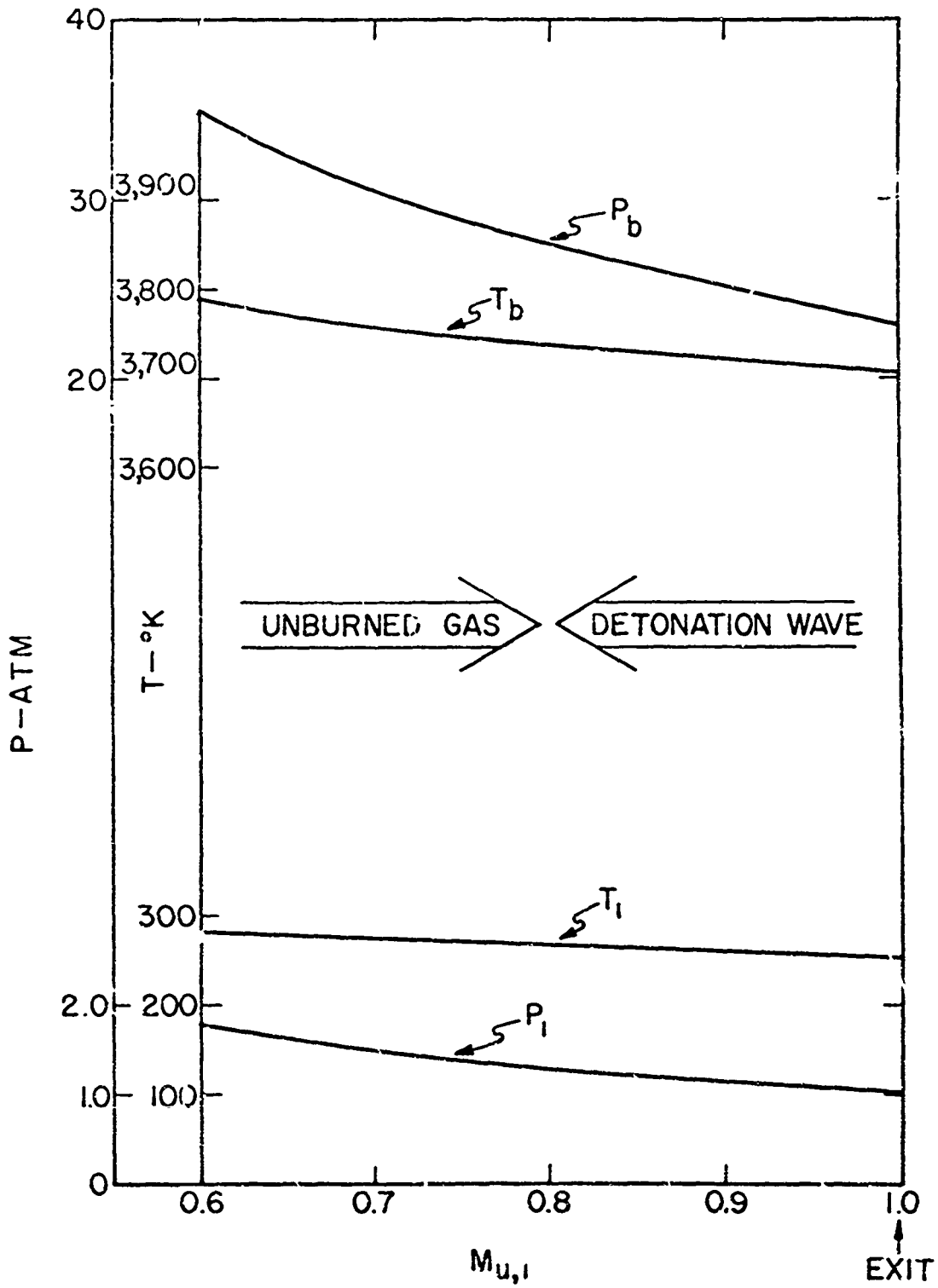

Figure 20 Theoretical Variations of Pressures and Temperatures before and behind the Detonation Wave in Subsonic Flow

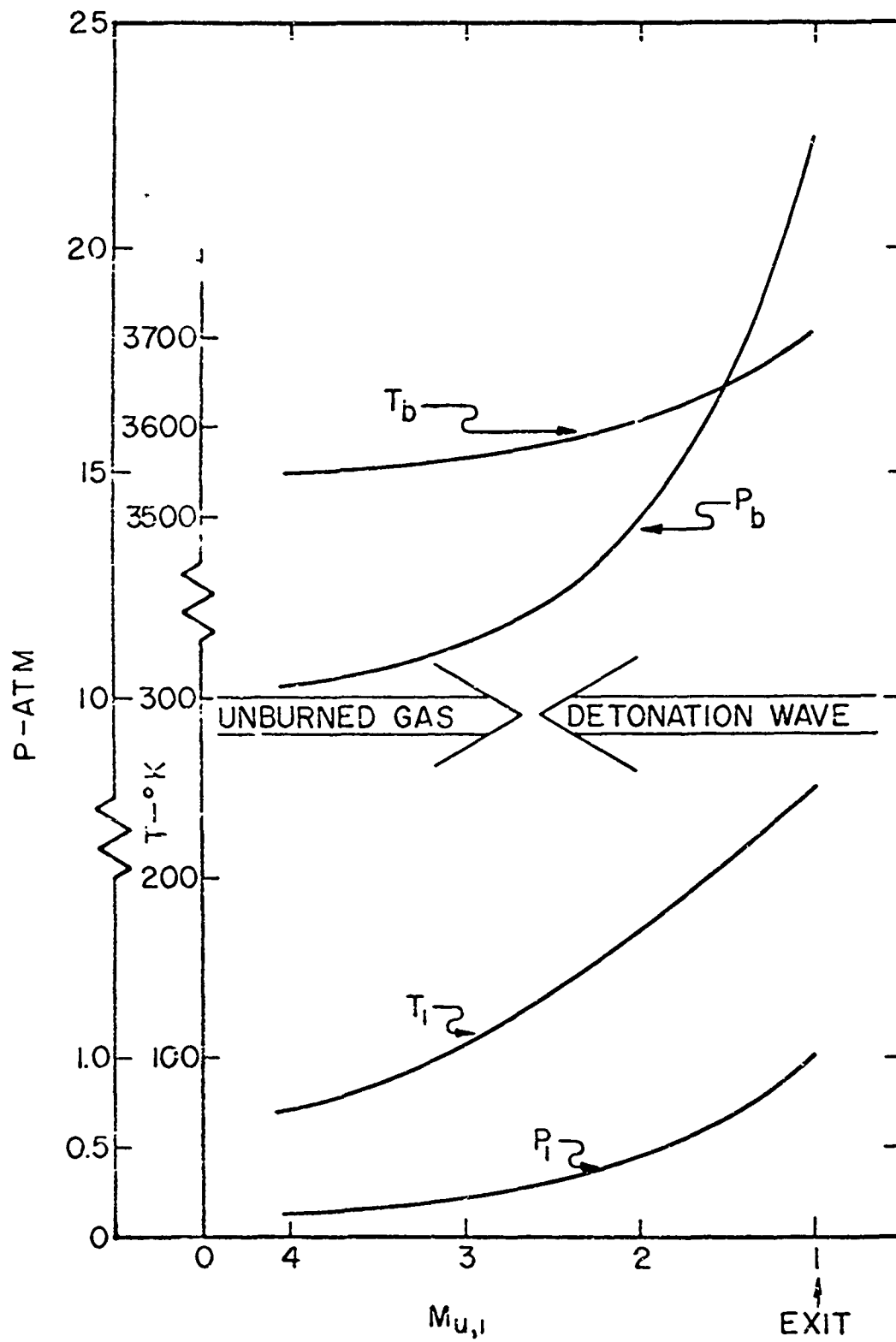

Figure 21 Theoretical Variations of Pressures and Temperatures before and behind the Detonation Wave in Supersonic Flow

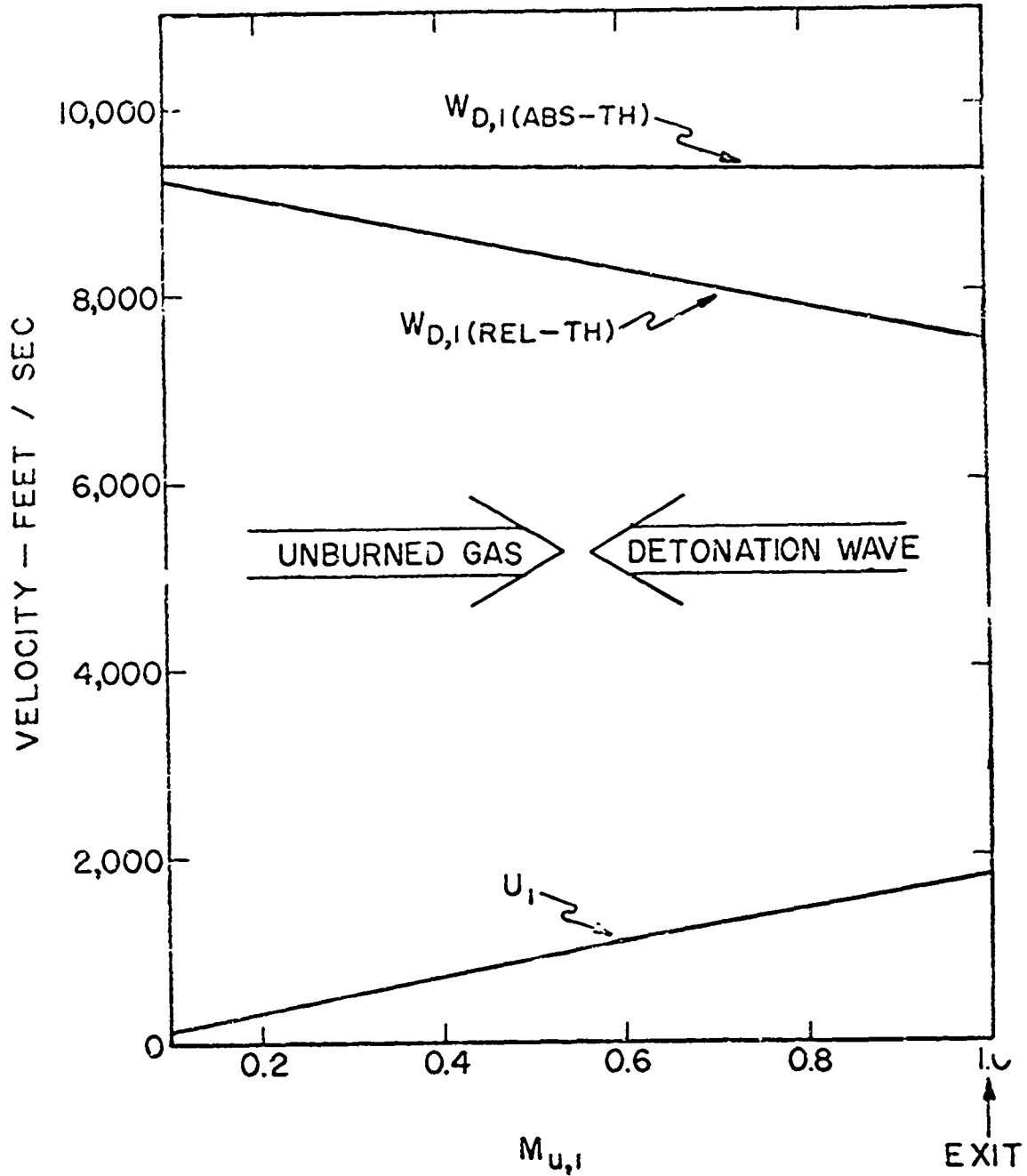

Figure 22 The Theoretical Variations of the Velocities in the Detonation Tube for Subsonic Flows

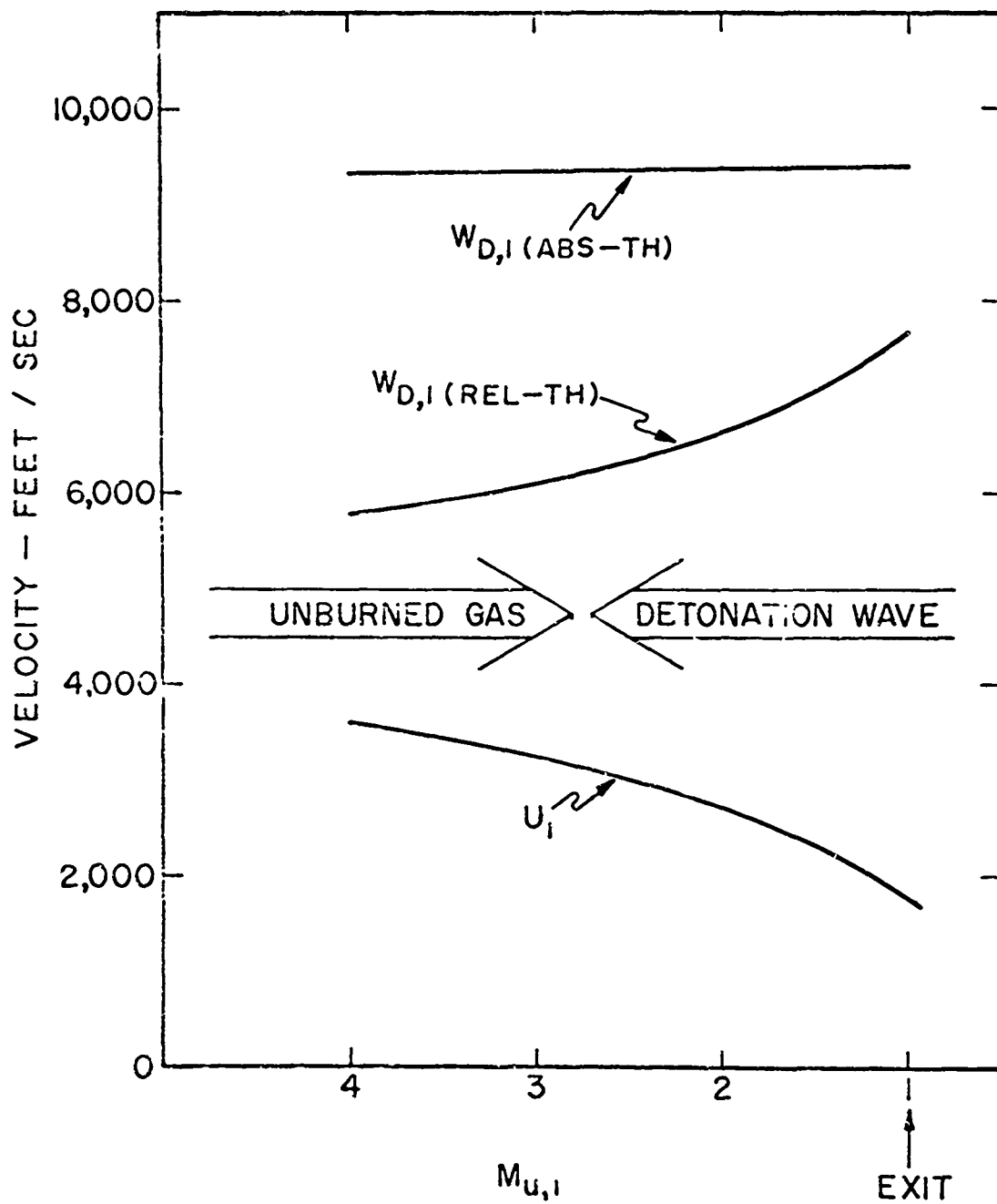

Figure 23 The Theoretical Variations of the Velocities in the Detonation Tube for Supersonic Flows

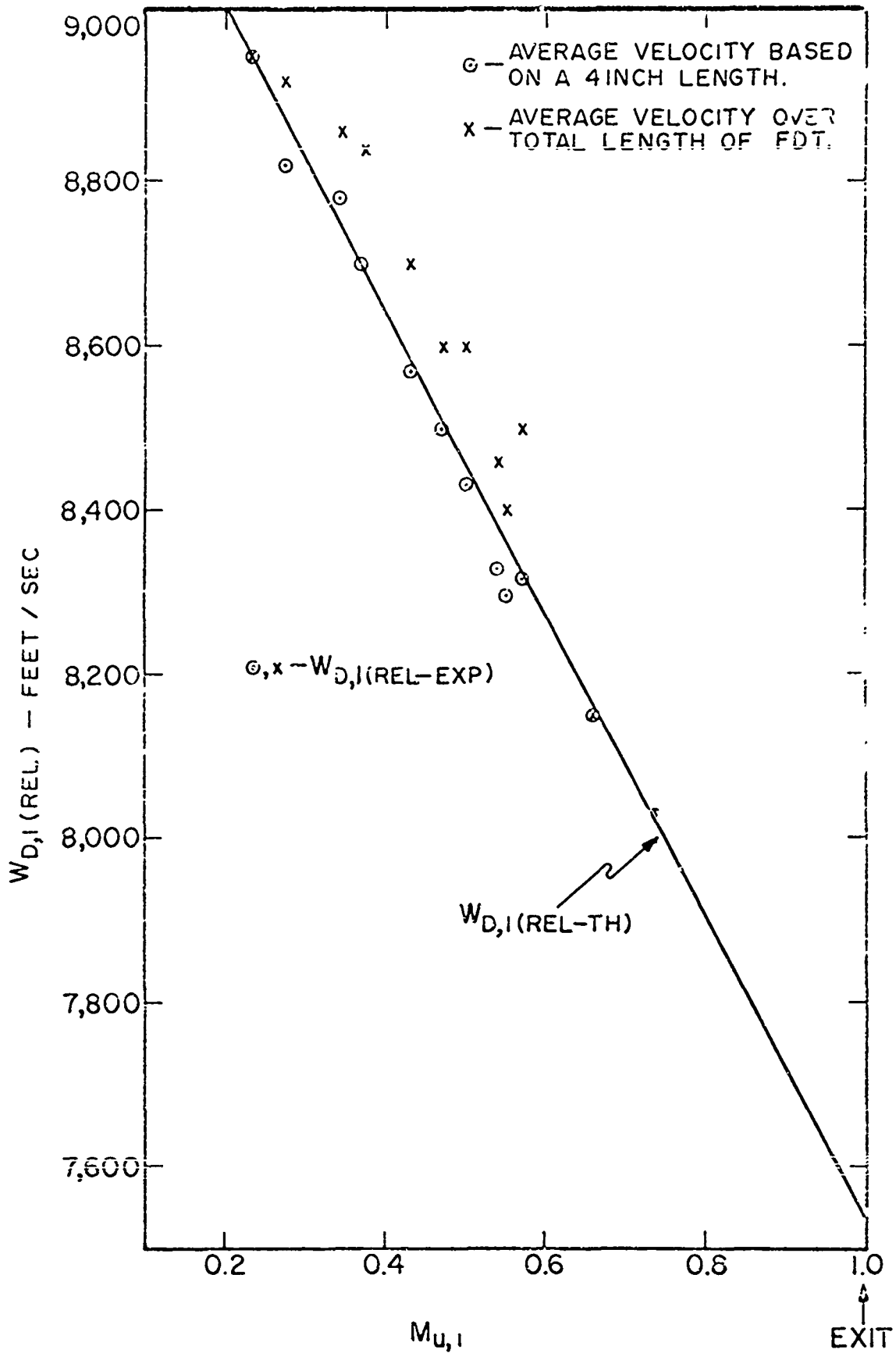

Figure 24 The Comparison of the Experimental and Theoretical Relative Velocities of a Detonation Wave Against a Subsonic Flow

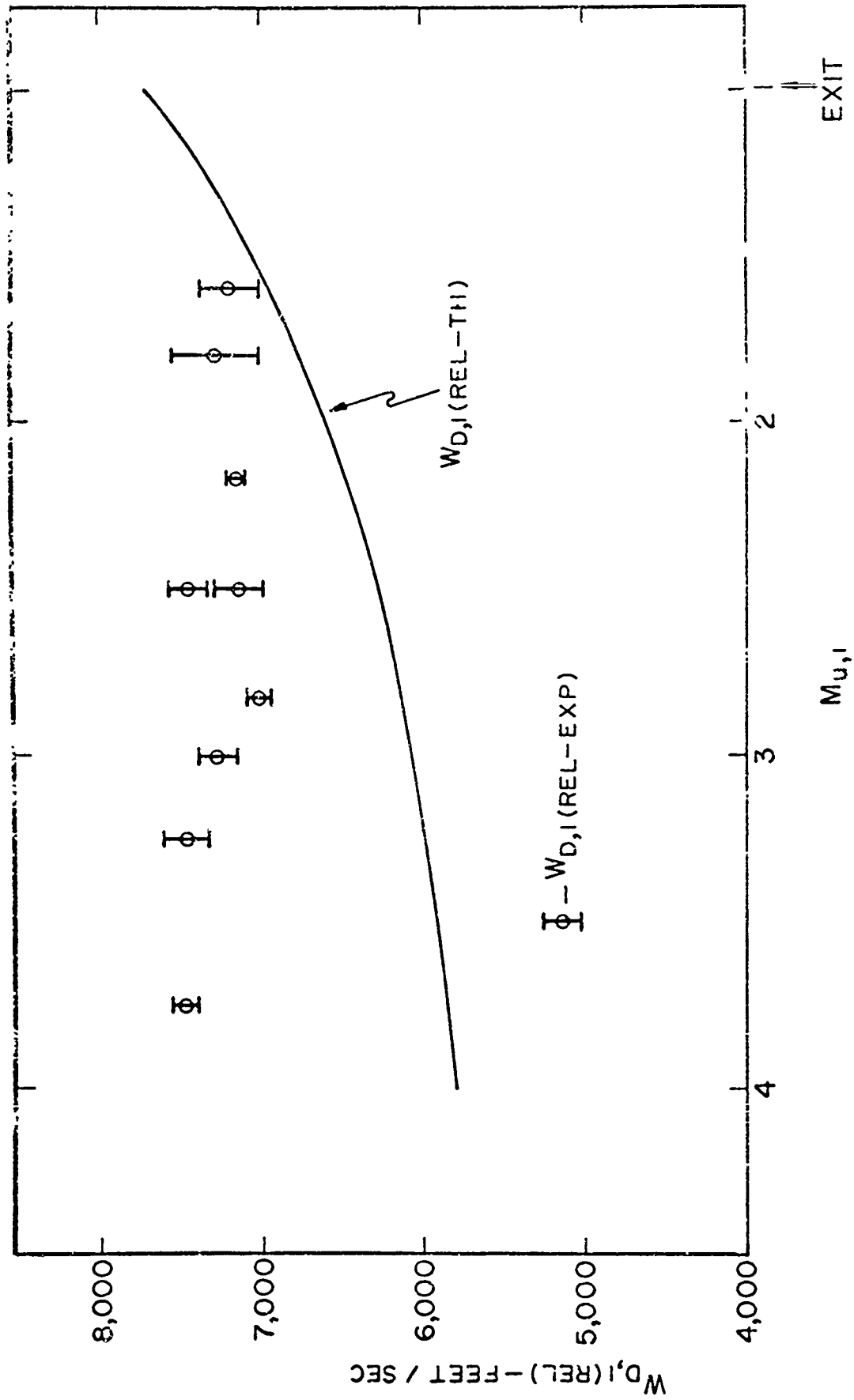

Figure 25 The Comparison of the Experimental and Theoretical Relative Velocities of a Detonation Wave Against a Supersonic Flow

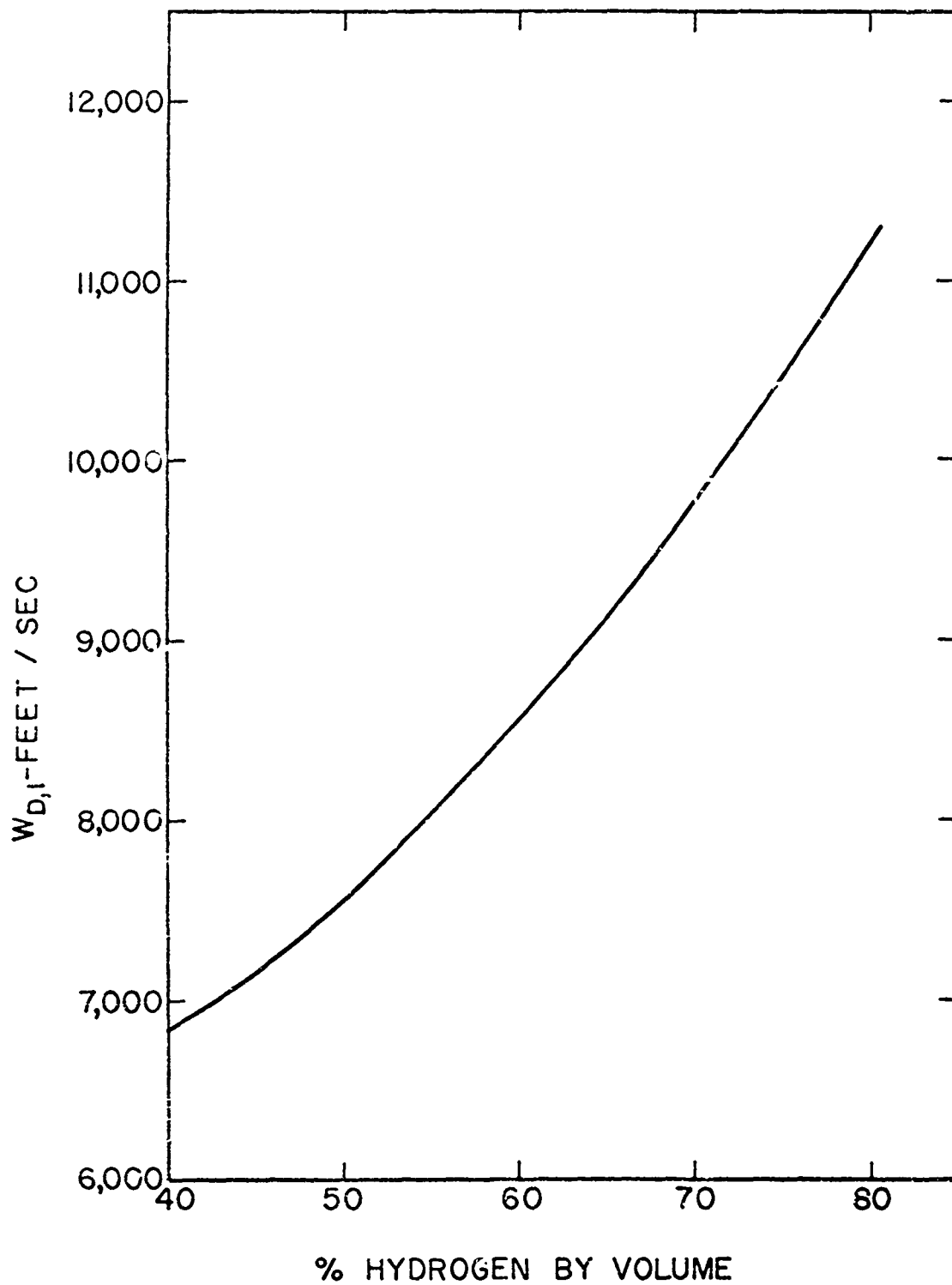
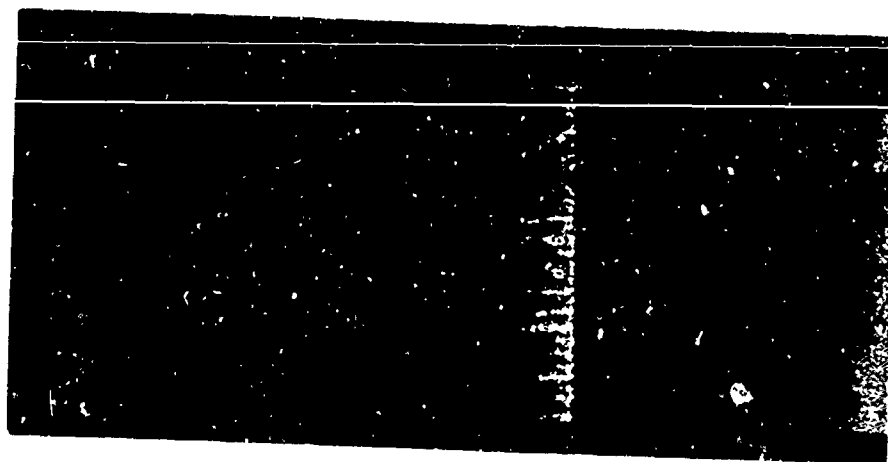

Figure 26 The Chapman-Jouguet Detonation Wave Velocity for Various Mixtures of Hydrogen-Oxygen at 1 ATM and 298°K

Wave→



←Flow

$$W_{D,1} \text{ (REL-EXP)} = 8850 \text{ feet/sec} \quad r = 7.96$$

$$W_{D,1} \text{ (ABS-TH)} = 9320 \text{ feet/sec} \quad u_1 \approx 576 \text{ feet/sec}$$

Figure 27 Subsonic Flow

Wave→

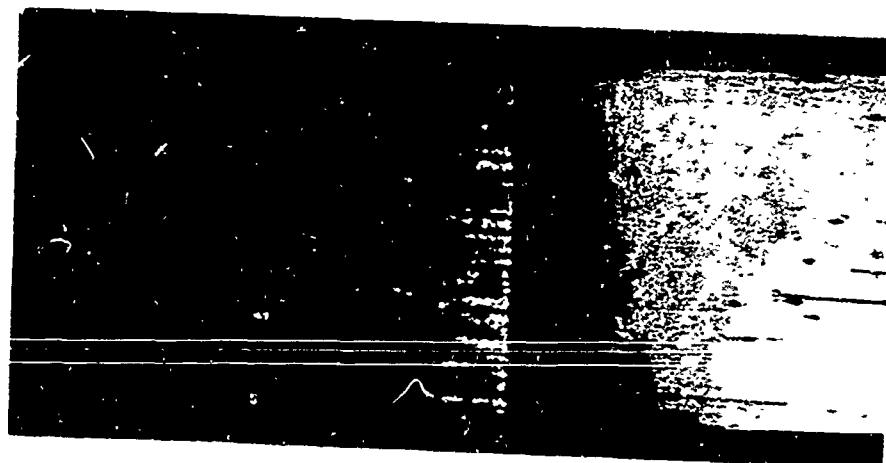

←Flow

$$W_{D,1} \text{ (REL-EXP)} = 8590 \text{ feet/sec} \quad r = 7.62$$

$$W_{D,1} \text{ (ABS-TH)} = 9450 \text{ feet/sec} \quad u_1 \approx 683 \text{ feet/sec}$$

Figure 28 Subsonic Flow

Wave→

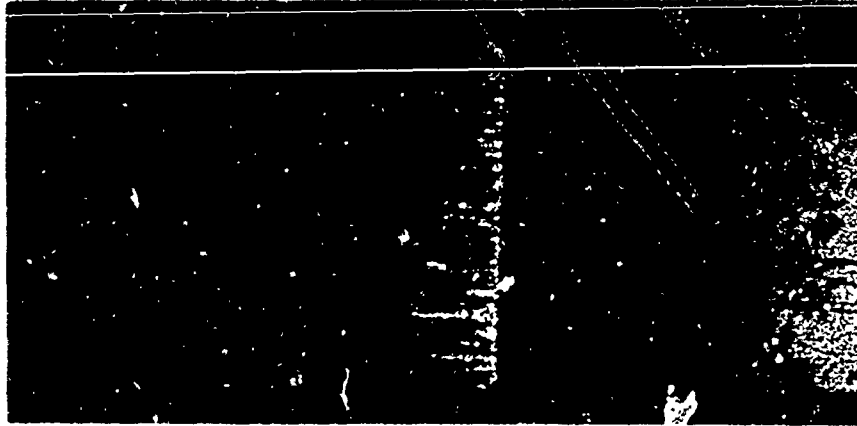

←Flow

$$\begin{aligned}W_{D,1} \text{ (REL-EXP)} &= 8370 \text{ feet/sec} & r &= 8.36 \\W_{D,1} \text{ (ABS-TH)} &= 9250 \text{ feet/sec} & u &= 845 \text{ feet/sec}\end{aligned}$$

Figure 29 Subsonic Flow

Wave→

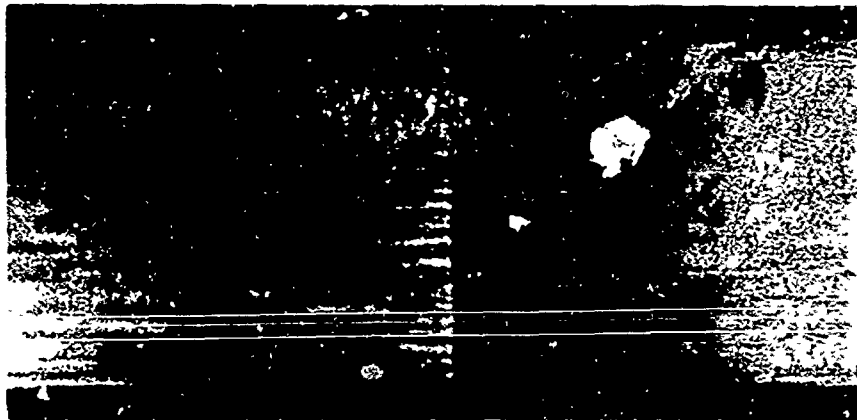

←Flow

$$\begin{aligned}W_{D,1} \text{ (REL-EXP)} &= 8110 \text{ feet/sec} & r &= 8.40 \\W_{D,1} \text{ (ABS-TH)} &= 9200 \text{ feet/sec} & u_1 &= 970 \text{ feet/sec}\end{aligned}$$

Figure 30 Subsonic Flow

Wave→

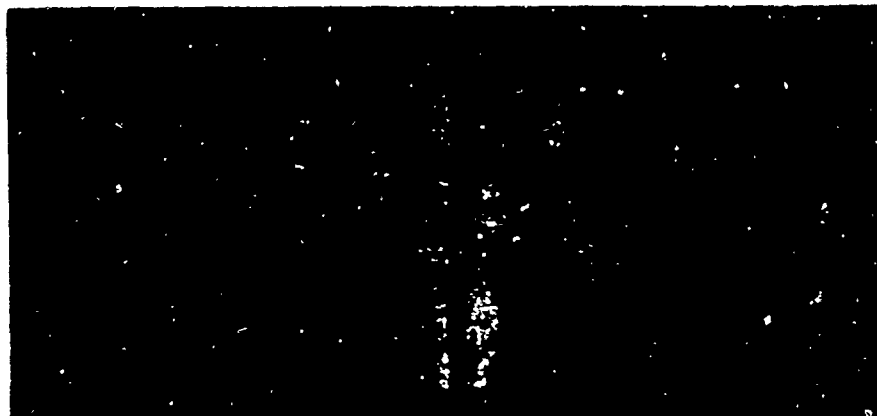

←Flow

$$W_{D,1} \text{ (REL-EXP)} = 6900 \text{ feet/sec} \quad r = 7.60$$

$$W_{D,1} \text{ (ABS-TH)} = 9480 \text{ feet/sec} \quad u_1 = 2985 \text{ feet/sec} \\ \text{(Mach 3)}$$

Figure 31 Supersonic Flow

Wave→



←Flow

$$W_{D,1} \text{ (REL-EXP)} = 7240 \text{ feet/sec} \quad r = 7.60$$

$$W_{D,1} \text{ (ABS-TH)} = 9480 \text{ feet/sec} \quad u_1 = 3860 \text{ feet/sec} \\ \text{(Mach 4)}$$

Figure 32 Supersonic Flow



$W_{D,1}$ (REL-EXP) = 8210 feet/sec $r = 8.40$
 $W_{D,1}$ (ABS-TH) = 9200 feet/sec $u_1 = 970$ feet/sec

Figure 33 Retonation Wave in Subsonic Flow



$W_{D,1}$ (REL-EXP) = 6900 feet/sec $r = 7.60$
 $W_{D,1}$ (ABS-TH) = 9480 feet/sec $u_1 = 2985$ feet/sec
 (Mach 3)

Figure 34 Retonation Wave in Supersonic Flow

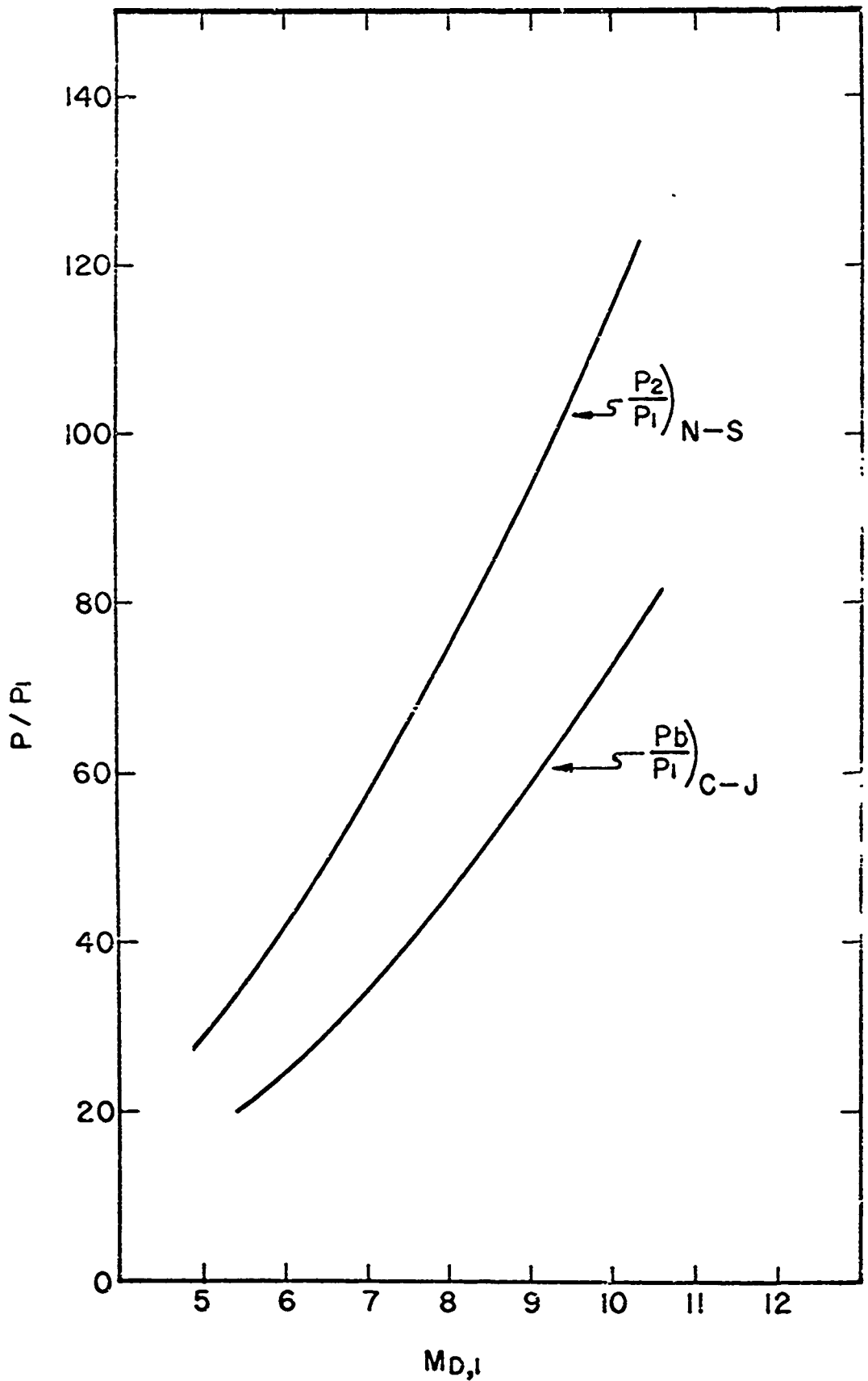

Figure 35 The Theoretical Variation of the Pressure Ratio of a Detonation Wave Versus Mach Number for Flows Against a Supersonic Stream

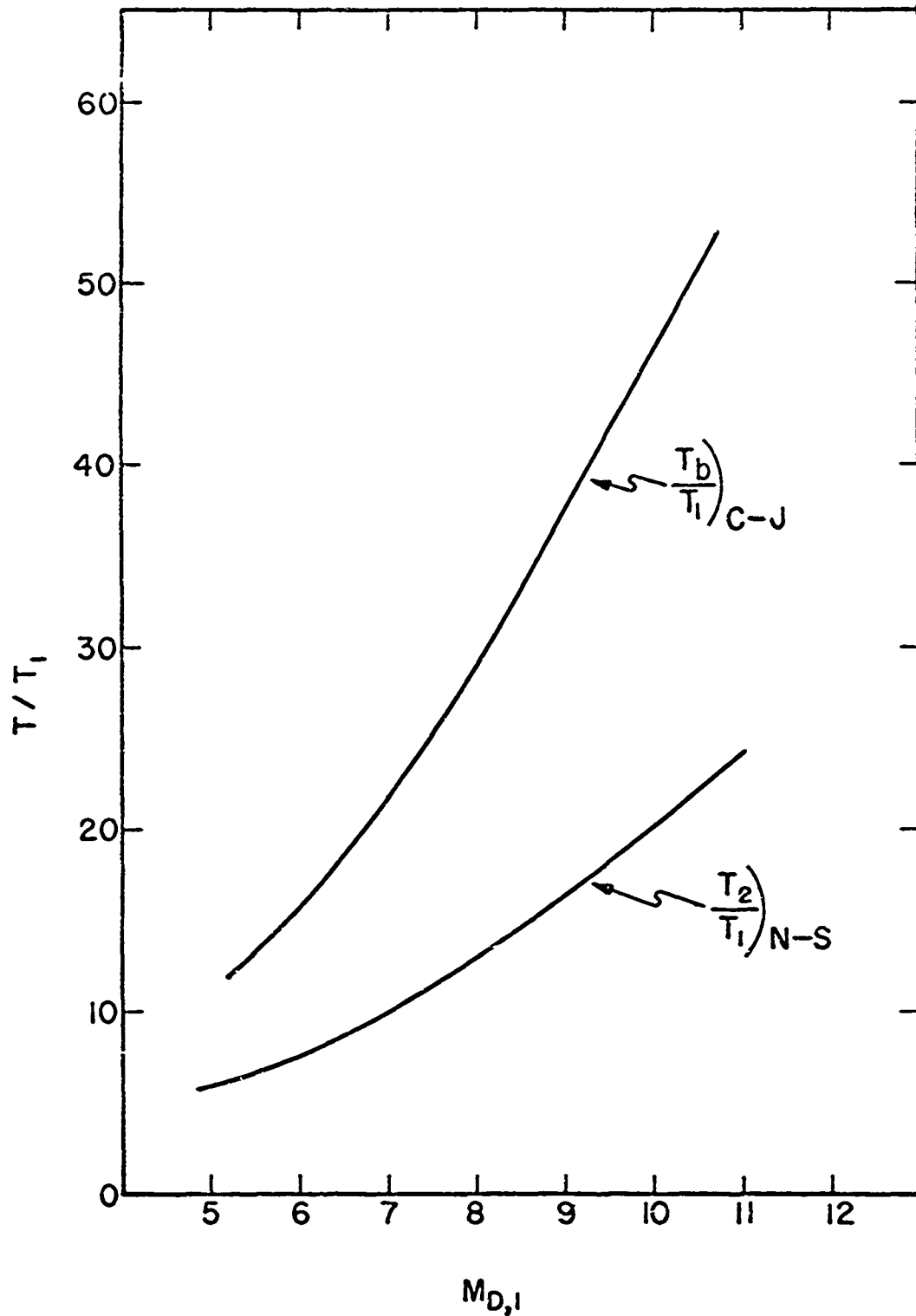

Figure 36 The Theoretical Variation of the Temperature Ratio of a Detonation Wave Versus Mach Number for Flows Against a Supersonic Stream

UNCLASSIFIED

Security Classification

DOCUMENT CONTROL DATA - R&D

(Security classification of title, body of abstract and indexing annotation must be entered when the overall report is classified)

1. ORIGINATING ACTIVITY (Corporate author) Air Force Institute of Technology (AU) Wright-Patterson AFB, Ohio		2a. REPORT SECURITY CLASSIFICATION UNCLASSIFIED	
		2b. GROUP	
3. REPORT TITLE "An Investigation of the Behavior of a Detonation Wave in a Flowing Combustible Mixture"			
4. DESCRIPTIVE NOTES (Type of report and inclusive dates) Scientific Final - August 1964 to June 1966			
5. AUTHOR(S) (Last name, first name, initial) McKenna, William W., Lt Colonel, USAF			
6. REPORT DATE June 1966		7a. TOTAL NO. OF PAGES 128	7b. NO. OF REFS 21
8a. In-house research		9a. ORIGINATOR'S REPORT NUMBER(S)	
b. PROJECT NO. 7065 -00 12			
c. 61445014		9b. OTHER REPORT NO(S) (Any other numbers that may be assigned this report)	
d. 681307		ARL 66-0112	
10. AVAILABILITY/LIMITATION NOTICES Distribution of this document is unlimited.			
11. SUPPLEMENTARY NOTES		12. SPONSORING MILITARY ACTIVITY Aerospace Research Laboratories (ARL) Office of Aerospace Research, USAF Wright-Patterson AFB, Ohio	
13. ABSTRACT The study of detonation waves in a flowing combustible mixture of gas could lead to a better understanding of combustion instability in rocket motors and to possible application to supersonic combustion. Apparatus was designed to measure the relative wave velocity and to photograph the wave profile as a fully developed detonation wave propagated against a flow of stoichiometric mixture of hydrogen-oxygen gases. The Mach number of the flowing gas was varied from 0.14 to 4. The subsonic flow results indicated that the absolute detonation wave velocity relative to the gas was independent of the speed of the flowing gas. But, the supersonic flow results indicated a strong wave which was contributed to the particular pressure profile in the tube during the supersonic flows. The schlieren photographs of the wave indicated propagation into the boundary layer and a convex curvature of the complete wave front was observed in the Mach 4 flow. Velocity measurements indicated that the detonation wave was steady but it is believed that retonation waves were observed in some experiments.			

14. KEY WORDS	LINK A		LINK E		LINK C	
	ROLE	WT	ROLE	WT	ROLE	WT
detonation waves flowing-gas detonation tube initiation detonation tube combustion instability supersonic combustion strong detonation wave photograph of detonation wave						

INSTRUCTIONS

1. ORIGINATING ACTIVITY: Enter the name and address of the contractor, subcontractor, grantee, Department of Defense activity or other organization (*corporate author*) issuing the report.

2a. REPORT SECURITY CLASSIFICATION: Enter the overall security classification of the report. Indicate whether "Restricted Data" is included. Marking is to be in accordance with appropriate security regulations.

2b. GROUP: Automatic downgrading is specified in DoD Directive 5200.10 and Armed Forces Industrial Manual. Enter the group number. Also, when applicable, show that optional markings have been used for Group 3 and Group 4 as authorized.

3. REPORT TITLE: Enter the complete report title in all capital letters. Titles in all cases should be unclassified. If a meaningful title cannot be selected without classification, show title classification in all capitals in parenthesis immediately following the title.

4. DESCRIPTIVE NOTES: If appropriate, enter the type of report, e.g., interim, progress, summary, annual, or final. Give the inclusive dates when a specific reporting period is covered.

5. AUTHOR(S): Enter the name(s) of author(s) as shown on or in the report. Enter last name, first name, middle initial. If military, show rank and branch of service. The name of the principal author is an absolute minimum requirement.

6. REPORT DATE: Enter the date of the report as day, month, year, or month, year. If more than one date appears on the report, use date of publication.

7a. TOTAL NUMBER OF PAGES: The total page count should follow normal pagination procedures, i.e., enter the number of pages containing information.

7b. NUMBER OF REFERENCES: Enter the total number of references cited in the report.

8a. CONTRACT OR GRANT NUMBER: If appropriate, enter the applicable number of the contract or grant under which the report was written.

8b, 8c, & 8d. PROJECT NUMBER: Enter the appropriate military department identification, such as project number, subproject number, system numbers, task number, etc.

9a. ORIGINATOR'S REPORT NUMBER(S): Enter the official report number by which the document will be identified and controlled by the originating activity. This number must be unique to this report.

9b. OTHER REPORT NUMBER(S): If the report has been assigned any other report numbers (*either by the originator or by the sponsor*), also enter this number(s).

10. AVAILABILITY/LIMITATION NOTICES: Enter any limitations on further dissemination of the report, other than those

imposed by security classification, using standard statements such as:

- (1) "Qualified requesters may obtain copies of this report from DDC."
- (2) "Foreign announcement and dissemination of this report by DDC is not authorized."
- (3) "U. S. Government agencies may obtain copies of this report directly from DDC. Other qualified DDC users shall request through _____."
- (4) "U. S. military agencies may obtain copies of this report directly from DDC. Other qualified users shall request through _____."
- (5) "All distribution of this report is controlled. Qualified DDC users shall request through _____."

If the report has been furnished to the Office of Technical Services, Department of Commerce, for sale to the public, indicate this fact and enter the price, if known.

11. SUPPLEMENTARY NOTES: Use for additional explanatory notes.

12. SPONSORING MILITARY / ACTIVITY: Enter the name of the departmental project office or laboratory sponsoring (*paying for*) the research and development. Include address.

13. ABSTRACT: Enter an abstract giving a brief and factual summary of the document indicative of the report, even though it may also appear elsewhere in the body of the technical report. If additional space is required, a continuation sheet shall be attached.

It is highly desirable that the abstract of classified reports be unclassified. Each paragraph of the abstract shall end with an indication of the military security classification of the information in the paragraph, represented as (TS), (S), (C), or (U).

There is no limitation on the length of the abstract. However, the suggested length is from 150 to 225 words.

14. KEY WORDS: Key words are technically meaningful terms or short phrases that characterize a report and may be used as index entries for cataloging the report. Key words must be selected so that no security classification is required. Identifiers, such as equipment model designation, trade name, military project code name, geographic location, may be used as key words but will be followed by an indication of technical context. The assignment of links, rules, and weights is optional.