

REPORT NUMBER 143

MARCH 1964

STRUCTURAL DESIGN LOADS

LIFT FAN FLIGHT RESEARCH AIRCRAFT PROGRAM

CONTRACT NUMBER DA47-107-ENG-001

GENERAL  ELECTRIC

ARCHIVE COPY

DDC AVAILABILITY NOTICES

1. Distribution of this document is unlimited.
2. This document is subject to special export controls and each transmittal to foreign governments or foreign nationals may be made only with prior approval of US Army Aviation Materiel Laboratories, Fort Eustis, Virginia 23604.
3. In addition to security requirements which must be met, this document is subject to special export controls and each transmittal to foreign governments or foreign nationals may be made only with prior approval of USAAVLABS, Fort Eustis, Virginia 23604.
4. Each transmittal of this document outside the agencies of the US Government must have prior approval of US Army Aviation Materiel Laboratories, Fort Eustis, Virginia 23604.
5. In addition to security requirements which apply to this document and must be met, each transmittal outside the agencies of the US Government must have prior approval of US Army Aviation Materiel Laboratories, Fort Eustis, Virginia 23604.
6. Each transmittal of this document outside the Department of Defense must have prior approval of US Army Aviation Materiel Laboratories, Fort Eustis, Virginia 23604.
7. In addition to security requirements which apply to this document and must be met, each transmittal outside the Department of Defense must have prior approval of US Army Aviation Materiel Laboratories, Fort Eustis, Virginia 23604.
8. This document may be further distributed by any holder only with specific prior approval of US Army Aviation Materiel Laboratories, Fort Eustis, Virginia 23604.
9. In addition to security requirements which apply to this document and must be met, it may be further distributed by the holder only with specific prior approval of US Army Aviation Materiel Laboratories, Fort Eustis, Virginia 23604.

DISCLAIMER

10. The findings in this report are not to be construed as an official Department of the Army position unless so designated by other authorized documents.

11. When Government drawings, specifications, or other data are used for any purpose other than in connection with a definitely related Government procurement operation, the United States Government thereby incurs no responsibility nor any obligation whatsoever; and the fact that the Government may have formulated, furnished, or in any way supplied the said drawings, specifications, or other data is not to be regarded by implication or otherwise as

in any manner licensing the holder or any other person or corporation, or conveying any rights or permission, to manufacture, use, or sell any patented invention that may in any way be related thereto.

12. Trade names cited in this report do not constitute an official endorsement or approval of the use of such commercial hardware or software.

DISPOSITION INSTRUCTIONS

13. Destroy this report when no longer needed. Do not return it to originator.

14. When this report is no longer needed, Department of the Army organizations will destroy it in accordance with the procedures given in AR 380-5.

REPORT NUMBER 143
MARCH, 1964

STRUCTURAL DESIGN LOADS

XV-5A LIFT FAN

FLIGHT RESEARCH AIRCRAFT PROGRAM

ADMISSION for

WPSTI	W. F. SECTION	<input checked="" type="checkbox"/>
DDC	DDC SECTION	<input type="checkbox"/>
UNASSIGNED		<input type="checkbox"/>
JUSTIFICATION		

DISTRIBUTION/AVAILABILITY CODES

LT.	AS. IL.	and/or SPECIAL

DDC
RECEIVED
FEB 6 1967
B

ADVANCED ENGINE AND TECHNOLOGY DEPARTMENT

GENERAL ELECTRIC COMPANY

CINCINNATI, OHIO 45215

19 MAY 1968
19 MAY 1966
MF

CONTENTS

SECTION		PAGE
1.0	SUMMARY	1
2.0	INTRODUCTION	3
3.0	METHOD OF APPROACH	6
	3.1 General	6
	3.2 Spin Recovery	24
	3.3 Gust Perturbation	24
	3.4 Aeroelastic Considerations	26
	3.5 Landing	34
	3.6 Distribution of Loading	34
	3.7 Propulsion System	89
	3.8 Miscellaneous Items	94
4.0	RESULTS	102
	4.1 Maneuvering Flight	102
	4.2 Spin Recovery	132
	4.3 Gust Perturbation	133
	4.4 Wing Loads	133
	4.5 Fuselage Loads	163
	4.6 Horizontal Tail Loads	269
	4.7 Vertical Tail Loads	269
	4.8 Aeroelastic Characteristics	279
	4.9 Miscellaneous Loads	292
5.0	CONCLUSION AND RECOMMENDATIONS	303
6.0	REFERENCES	304

LIST OF FIGURES

Figure		Page
2.1	Three View - XV-5A	4
2.2	Cutaway Drawing - XV-5A	5
3.1	V-n Diagram	11
3.2	Design Mach No. - Altitude Envelope	12
3.3	Lateral Control Rate for One-Degree of Freedom Analysis	18
3.4	Maximum Lateral Control Rate for Three-Degrees of Freedom Analysis	19
3.5	Empennage Torsional Stiffness	31
3.6	Empennage Bending Stiffness	32
3.7	Aft Fuselage Bending Stiffness	33
3.8	Wing Panel Point Geometry	36
3.9	Loading Distribution Due to Angle of Attack, $M = 0.285$ Flaps Retracted	37
3.10	Loading Distribution at Zero Angle of Attack, $M = 0.285$, Flaps Retracted	38
3.11	Distribution of Local Aerodynamic Center, $M = -.285$, Flaps Retracted	39
3.12	Distribution of Local Pitching Moment, $M = 0.285$, Flaps Retracted	40
3.13	Loading Distribution Due to Angle of Attack, $M = 0.285$, Flaps Retracted	41
3.14	Loading Distribution at Zero Angle of Attack, $M = 0.285$, Flaps extended 45°	42
3.15	Distribution of Local Aerodynamic Center, $M = 0.285$, Flaps Extended 45°	43
3.16	Distribution of Local Pitching Moment, $M = 0.285$, Flaps Extended 45°	44
3.17	Loading Distribution Due to Angle of Attack, $M = 0.8$	45
3.18	Loading Distribution at Zero Angle of Attack, $M = 0.8$	46
3.19	Distribution of Local Aerodynamic Center, $M = 0.8$	47
3.20	Distribution of Local Pitching Moment, $M = 0.8$	48
3.21	Loading Distribution Due to Angle of Attack, $M = 0.9$	49
3.22	Loading Distribution at Zero Angle of Attack, $M = 0.9$	50
3.23	Distribution of Local Aerodynamic Center, $M = 0.9$	51
3.24	Distribution of Local Pitching Moment, $M = 0.9$	52
3.25	Loading Distribution Due to Aileron Deflection, $M = 0.285$	53

Figure	Page
3.26 Distribution of Center of Pressure for Aileron Induced Loading, $M = 0.285$	54
3.27 Loading Distribution Due to Rolling Velocity	55
3.28 Wing Chordwise Pressure Distribution, Upper Surface, $M = 0.80$	56
3.29 Wing Chordwise Pressure Distribution, Upper Surface, $M = 0.80$	57
3.30 Wing Chordwise Pressure Distribution, Upper Surface, $M = 0.80$	58
3.31 Wing Chordwise Pressure Distribution, Upper Surface, $M = 0.80$	59
3.32 Wing Chordwise Pressure Distribution, Upper Surface, $M = 0.80$	60
3.33 Wing Chordwise Pressure Distribution, Upper Surface, $M = 0.80$	61
3.34 Wing Chordwise Pressure Distribution, Lower Surface, $M = 0.80$	62
3.35 Wing Chordwise Pressure Distribution, Lower Surface, $M = 0.80$	63
3.36 Wing Chordwise Pressure Distribution, Lower Surface, $M = 0.80$	64
3.37 Wing Chordwise Pressure Distribution, Lower Surface, $M = 0.80$	65
3.38 Wing Chordwise Pressure Distribution, Lower Surface, $M = 0.80$	66
3.39 Wing Chordwise Pressure Distribution, Lower Surface, $M = 0.80$	67
3.40 Fuselage Weight Distribution	74
3.41 Fuselage Vertical Airload Distribution Low Speed, High Angle-of-Attack	75
3.42 Fuselage Vertical Airload Distribution Low Speed, Zero Angle-of-Attack	76
3.43 Fuselage Vertical Airload Distribution Low Speed, Per Degree Angle-of-Attack	77
3.44 Fuselage Vertical Airload Distribution High Speed, Zero Angle-of-Attack	78
3.45 Fuselage Vertical Airload Distribution High Speed, Per Degrees Angle-of-Attack	79
3.46 Fuselage Side Airload Distribution High Speed, Per Degree Sideslip Angle	80
3.47 Dimensionless Spanwise Loading Distributions Due to α , δ_E & ϕ Horizontal Tail	82

Figure		Page
3.48	Dimensionless Spanwise Loading Distribution Due to β , δ_R & $\dot{\phi}$, Vertical Tail	83
3.49	Empennage Longitudinal A. C. Variation with Mach Number	84
3.50	Vertical Tail Loading Characteristics Due to δ_R - Type of Loading	85
3.51	Vertical Tail Loading Characteristics Due to β - Type of Loading	86
3.52	Vertical Tail Loading Characteristics Due to $\dot{\phi}$ - Type of Loading	87
3.53	Horizontal Tail Loading Characteristics Due to α , δ_E & $\dot{\phi}$ - Types of Loading	88
3.54	Thrust Modulator Door Hinge Moments, 26" - Scale Model	96
3.55	Wing Fan Door Side Force, Ames Tests	98
3.56	Wing Fan Door Closure Moments, Ames Tests	99
3.57	Wing Fan Door Twisting Moments, Ames Tests	100
3.58	Wing Fan Door Forces & Moments Due to Angle-of-Attack, Ames Tests	101
4.1	Engine Characteristics Gross Thrust and Ram Drag Per Engine	107
4.2	Symmetrical Flight Loading Curves Effects of Altitude on Wing, Wing Body and Horizontal Tail Loads	108
4.3	Symmetrical Flight Loading Curves Wing and Wing-Body Loads and Elevator Deflection	109
4.4	Symmetrical Flight Loading Curves Horizontal Tail Loads and Elevator Deflection	110
4.5	Rolling Pull-Out Characteristics, 500 Knots at S. L., One Degree of Freedom	114
4.6	Rolling Pull-Out Characteristics, 180 Knots at S. L., One Degree of Freedom, Flaps Extended 45°	115
4.7	Elastic Roll Derivatives	116
4.8	Rolling Pull-Out Maneuver Time History	117
4.9	Rolling Pull-Out Maneuver Time History	117
4.10	Loading Curves Rolling - Pull-Out Maneuver	119
4.11	Effects of Altitude, Rolling Pull-Out Maneuver	120
4.12	Steady-State Roll Maneuver	121
4.13	Steady-State Roll Maneuver	122
4.14	Steady-State Roll Maneuver	123
4.15	Lateral Gust and Rudder Maneuver Loading Curves	127
4.16	Lateral Gust and Rudder Maneuver Loading Curves	128

Figure		Page
4.17	Lateral Gust and Rudder Maneuver Loading Envelope Curves	129
4.18	Rudder Maneuver Time History	130
4.19	Rudder Maneuver Calculated Ratios of Overswing to Steady-State Sideslip Angles	131
4.20	Wing Aeroelastic Twist Distribution, Condition EF-1	141
4.21	Fuselage Loads Body-Axes System	165
4.22	Fuselage Vertical Loading Envelope Curves Symmetrical Flight and Landing Conditions	166
4.23	Fuselage Loading Envelope Curves Unsymmetrical Flight and Landing Conditions	166A
4.24	Fuselage Loading Envelope Curves Unsymmetrical Flight and Landing Conditions	167
4.25	Fuselage Loading Envelope Curves Symmetrical Flaps-Down Flight Condition	190
4.26	Fuselage Loading Envelope Curves Symmetrical Flaps-Up Flight Condition	191
4.27	Fuselage Bending Moment Envelope Curves Dynamic Overswing Rudder Maneuvers	193
4.28	Fuselage Bending Moment Envelope Curves Lateral Gust Condition	194
4.29	Fuselage Torsional Moment Envelope Curve Lateral Gust Rudder Maneuver Condition	195
4.30	Fuselage Lateral Bending Moment Envelope Curve Rudder and Lateral Gust Loading Conditions	196
4.31	Fuselage Bending Moment Envelope Curves Rudder and Lateral Gust Conditions	197
4.32	Vertical Fuselage Loading Appropriate to Lateral Gust and Rudder Conditions	198
4.33	Vertical Fuselage Loading Appropriate to Lateral Gust and Rudder Conditions	199
4.34	Vertical Fuselage Loading Appropriate to Gust and Rudder Conditions	200
4.35	Fuselage Bending Moment Curves Rolling Pullout Maneuver	214
4.36	Fuselage Moment Envelope Curves Rolling Pullout Maneuver	215
4.37	Fuselage Bending Moment Envelope Curves Symmetrical Landing Conditions	219
4.38	Fuselage Bending Moment Envelope Curves Unsymmetrical Landing Conditions	220
4.39	Fuselage Bending Moment Envelope Curves Unsymmetrical Landing Conditions	221

Figure		Page
4. 40	Fuselage Bending Moment Curves Unsymmetrical Spin and Parachute Conditions	233
4. 41	Fuselage Loading Envelope Curves Fuselage Vertical Loading from Spin and Parachute Conditions	234
4. 42	Fuselage Moment Envelope Curves Unsymmetrical Spin and Parachute Conditions	235
4. 43	Fuselage Aerodynamic Loading Curves Fuselage Low-Speed Vertical Airloads	245
4. 44	Fuselage Aerodynamic Loading Curves Fuselage Low-Speed Vertical Airload Applicable to High Angles-of-Attack	246
4. 45	Fuselage Aerodynamic Loading Curves Fuselage High-Speed Vertical Airloads	247
4. 46	Fuselage Aerodynamic Loading Curves Fuselage High-Speed Lateral Airloads	248
4. 47	Fuselage Aerodynamic Loading Curves Unit Vertical Load Factor	249
4. 48	Fuselage Aerodynamic Loading Curves Unit Lateral Load Factor	250
4. 49	Fuselage Inertial Loading Curves One-Radian-Per-Second Rolling Acceleration	251
4. 50	Fuselage Inertial Loading Curves One-Radian-Per-Second-Squared Pitching Acceleration	252
4. 51	Fuselage Inertial Loading Curves One-Radian-Per-Second-Squared Yawing Acceleration	253
4. 52	Fuselage Aerodynamic Loading Curves Unit Ram-Drag Condition	254
4. 53	Fuselage Thrust Loading Curves Unit Thrust Condition	255
4. 54	Fuselage Loading Curves Reacted Unit Vertical Load at Forward Wing Spar	256
4. 55	Fuselage Loading Curves Reacted Unit Vertical Load at Aft Wing Spar	257
4. 56	Fuselage Loading Curves Reacted Unit Vertical Load on Nose Gear	258
4. 57	Fuselage Loading Curves Reacted Unit Forward Load on Nose Gear	259
4. 58	Fuselage Loading Curves Reacted Unit Side Load on Nose Gear	260
4. 59	Fuselage Loading Curves Reacted Unit Pitching Moment on Each Main Gear	261
4. 60	Fuselage Loading Curves Reacted Unit Forward Load on Each Main Gear	262

Figure		Page
4.61	Fuselage Loading Curves Reacted Unit Vertical Load on Each Main Gear	263
4.62	Fuselage Loading Curves Reacted Unit Torsional Moment on Left Main Gear	264
4.63	Fuselage Loading Curves Reacted Unit Yawing Moment on Left Main Gear	265
4.64	Fuselage Loading Curves Reacted Unit Side Load on Left Main Gear	266
4.65	Fuselage Loading Curves Reacted Unit Forward Load on Left Main Gear	267
4.66	Fuselage Loading Curves Reacted Unit Vertical Load on Left Main Gear	268
4.67	Stabilizer and Elevator Unit Shear Due to α & δ_E	270
4.68	Stabilizer and Elevator Unit Shear Due to α & δ_E	271
4.69	Stabilizer Unit Torsion Due to α & δ_E	272
4.70	Fin and Rudder Unit Shear Due to β	273
4.71	Fin and Rudder Unit Bending Due to β	274
4.72	Fin and Rudder Unit Torsion Due to β	275
4.73	Fin and Rudder Unit Shear Due to δ_R	276
4.74	Fin and Rudder Unit Bending Due to δ_R	277
4.75	Fin and Rudder Unit Torsion Due to δ_R	278
4.76	Wing-Body Elastic Coefficients, Rolling Mode	281
4.77	Empennage Elastic Coefficients, Pitching Mode	282
4.78	Empennage Elastic Coefficients, Yawing Mode	283
4.79	Design Loading Conditions, Main Landing Gear Door, Extended	293
4.80	Main Landing Gear Door Loading at High Speed	294
4.81	Design Loading Conditions, Nose Landing Gear Door, Extended	295
4.82	Design Wing-Fan Door Loading, Conventional Flight	297
4.83	Aileron Design Loading	299
4.84	Elevator Design Loading	300
4.85	Rudder Design Loading	301

LIST OF TABLES

Table		Page
3.1	Wing Flexibility Matrix, (S)-rad/lb., Symmetrical Loading	29
3.2	Wing Flexibility Matrix, (S)-rad/lb., Antisymmetrical Loading	30
3.3	XV-5A Fuselage Weight Distribution Forward Center-of-Gravity Location	72
3.4	XV-5A Fuselage Weight Distribution Aft Center-of-Gravity Location	73
3.5	Unit Pitch Fan Mount Reactions	90
3.6	Wing Fan Unit (Starboard) Mount Reactions	91
3.7	Unit Wing Fan (Port) Mount Reactions	92
3.8	Unit Engine (J85-5) Mount Reactions	93
4.1	Symmetrical Maneuvering Loads Summary (Sheet 1 of 4)	103
4.1	Symmetrical Maneuvering Loads Summary (Sheet 2 of 4)	104
4.1	Symmetrical Maneuvering Loads Summary (Sheet 3 of 4)	105
4.1	Symmetrical Maneuvering Loads Summary (Sheet 4 of 4)	106
4.2	Lateral Loads Summary (Sheet 1 of 2)	125
4.2	Lateral Loads Summary (Sheet 2 of 2)	126
4.3	Wing Panel Point Loads, Symm. Flt., Flaps Retracted, Pt. B of V-n Diagram	135
4.4	Wing Panel Point Loads, Symm. Flt., Flaps Retracted, Pt. C of V-n Diagram	136
4.5	Wing Panel Point Loads, Symm. Flt., Flaps Retracted, Pt. D of V-n Diagram	137
4.6	Wing Panel Point Loads, Symm. Flt., Flaps Retracted, Pt. A of V-n Diagram	138
4.7	Wing Panel Point Loads, Symm. Flt., Flaps Retracted, Pt. E of V-n Diagram	139
4.8	Wing Panel Point Loads, Symm. Flt., Flaps Retracted, Pt. B of V-n Diagram	140
4.9	Wing Panel Point Loads, Symm. Flt., Flaps Extended, Pt. A of V-n Diagram	143

Table	Page
4. 10 Wing Panel Point Loads, Symm. Flt., Flaps Extended, Pt. A of V-n Diagram	144
4. 11 Wing Panel Point Loads, Symm. Flt., Flaps Extended, Pt. B of V-n Diagram	145
4. 12 Wing Panel Point Loads, Symm. Flt., Flaps Extended, Pt. B of V-n Diagram	146
4. 13 Wing Panel Point Loads, Symm. Flt., Flaps Extended, Pt. F of V-n Diagram	147
4. 14 Wing Panel Point Loads, Symm. Flt., Flaps Extended, Pt. F of V-n Diagram	148
4. 15 Wing Panel Point Loads, Symm. Flt., Flaps Extended, Pt. L of V-n Diagram	149
4. 16 Wing Panel Point Loads Symm. Flt., Flaps Extended, Pt. L of V-n Diagram	150
4. 17 Wing Panel Point Loads Symm. Contributions, Flaps Retracted	152
4. 18 Wing Panel Point Loads Antisymm. Contributions, Flaps Retracted	153
4. 19 Wing Panel Point Loads, Symm. Contributions (Flaps-dn.) Plus Antisymm. Increments ($\alpha_A=0$)	155
4. 20 Wing Panel Point Loads, Antisymm. Contributions, Flaps Extended	156
4. 21 Wing Panel Point Loads Unit Inertia	157
4. 22 Fuselage Reactions, Unit Inertia	158
4. 23 Wing Panel Point Loads Unit Aerodynamic M=. 285 At 2500 Ft. (q=109. 8 psf) Flaps Retracted	159
4. 24 Wing Panel Point Loads, Unit Aerodynamic M=. 285 At 2500 Ft. (q=109. 8 psf) Flaps Extended 45°	160
4. 25 Wing Panel Point Loads, Unit Aerodynamic, M=. 8 At 6316 Ft. (q=750. 8 psf)	161
4. 26 Wing Panel Point Loads, Unit Aerodynamic, M=. 9 At 9340 Ft. (q=846. 7 psf)	162
4. 27 Fuselage Loading Symmetric Flight Maneuver	169
4. 28 Fuselage Loading Symmetric Flight Maneuver	170
4. 29 Fuselage Loading Symmetric Flight Maneuver	171
4. 30 XV-5A Fuselage Loading Symmetric Flight Maneuver	172
4. 31 Fuselage Loading Symmetric Flight Maneuver	173
4. 32 Fuselage Loading Symmetric Flight Maneuver	174
4. 33 Fuselage Loading Symmetric Flight Maneuver	175
4. 34 Fuselage Loading Symmetric Flight Maneuver	176
4. 35 Fuselage Loading Symmetric Flight Maneuver	177

Table	Page	
4.36	Fuselage Loading Symmetric Flight Maneuver	178
4.37	Fuselage Loading Symmetric Flight Maneuver	179
4.38	Fuselage Loading Symmetric Flight Maneuver	180
4.39	Fuselage Loading Symmetric Flight Maneuver	181
4.40	Fuselage Loading Symmetric Flight Maneuver	182
4.41	Fuselage Loading Symmetric Flight Maneuver	183
4.42	Fuselage Loading Symmetric Flight Maneuver	184
4.43	Fuselage Loading Symmetric Flight Maneuver	185
4.44	Fuselage Loading Symmetric Flight Maneuver	186
4.45	Fuselage Loading Symmetric Flight Maneuver	187
4.46	Fuselage Loading Symmetric Flight Maneuver	188
4.47	Fuselage Loading Symmetric Flight Maneuver	189
4.48	Fuselage Loading Unsymmetrical Flight Maneuvers	201
4.49	Fuselage Loading Unsymmetrical Flight Maneuvers	202
4.50	Fuselage Loading Unsymmetrical Flight Maneuvers	203
4.51	Fuselage Loading Unsymmetrical Flight Maneuvers	204
4.52	Fuselage Loading Unsymmetrical Flight Maneuvers	205
4.53	Fuselage Loading Unsymmetrical Flight Maneuvers	206
4.54	Fuselage Loading Unsymmetrical Flight Maneuvers	207
4.55	XV-5A Rolling-Pullout Maneuver	209
4.56	Fuselage Loading Unsymmetrical Flight Maneuvers	210
4.57	Fuselage Loading Unsymmetrical Flight Maneuvers	211
4.58	Fuselage Loading Unsymmetrical Flight Maneuvers	212
4.59	Fuselage Loading Unsymmetrical Flight Maneuvers	213
4.60	XV-5A Symmetrical Landing Conditions	217
4.61	XV-5A Unsymmetrical Landing Conditions	218
4.62	Fuselage Loading Landing Conditions	222
4.63	Fuselage Loading Landing Conditions	223
4.64	Fuselage Loading Landing Conditions	224
4.65	Fuselage Loading Landing Conditions	225
4.66	Fuselage Loading Landing Conditions	226
4.67	Fuselage Loading Landing Conditions	227
4.68	Fuselage Loading Landing Conditions	228
4.69	Fuselage Loading Landing Conditions	229
4.70	Fuselage Loading Landing Conditions	230
4.71	XV-5A Span-With-Parachute and High Speed Parachute Conditions	232
4.72	Fuselage Loading Flight Parachute Conditions	236
4.73	Fuselage Loading Flight Parachute Conditions	237
4.74	Fuselage Loading Flight Parachute Conditions	238
4.75	Fuselage Loading Flight Parachute Conditions	239
4.76	Fuselage Loading Flight Parachute Conditions	240

Table		Page
4.77	Fuselage Loading Flight Parachute Conditions	241
4.78	Fuselage Loading Flight Parachute Conditions	242
4.79	Fuselage Loading Flight Parachute Conditions	243
4.80	Elastic Coefficients in Terms of Elastic/Rigid Ratios	280
4.81	Theoretical Stability Derivatives, Empennage (Rigid Fuselage), $M=.3$, Alt.= S. L.	284
4.82	Theoretical Stability Derivatives, Empennage (Rigid Fuselage), $M=.3$, Alt.=20,000	285
4.83	Theoretical Stability Derivatives, Empennage (Rigid Fuselage), $M=.6$, Alt.=20,000	286
4.84	Theoretical Stability Derivatives, Empennage (Rigid Fuselage), $M=.6$, Alt.=20,000	287
4.85	Theoretical Stability Derivatives, Empennage (Rigid Fuselage), $M=.8$, Alt.= S. L.	288
4.86	Theoretical Stability Derivatives, Empennage (Rigid Fuselage), $M=.8$, Alt.=20,000	289
4.87	Theoretical Stability Derivatives, Empennage (Rigid Fuselage), $M=.9$, Alt.=S. L.	290
4.88	Theoretical Stability Derivatives, Empennage (Rigid Fuselage), $M=.9$, Alt.=20,000	291

1.0 SUMMARY

This report presents the XV-5A structural loads analysis in accordance with requirements of Structural Design Criteria (Reference 1).

The report shows the methods of analysis, calculated design loads, maneuvering time-histories, aeroelastic characteristics and a compilation of other pertinent characteristic loading data. The analyses extensively utilized XV-5A wind-tunnel model data and mechanized digital computer (IBM 704) programs.

From these studies, airframe strength requirements were developed. Progressive parametric evaluation of the airplane's inherent capabilities then served to corroborate the airframe structural integrity or, as for one particular maneuver, defined safe flight-envelope operating limits.

All requirements of the Structural Design Criteria have been met, with the exception of certain rolling pull-out conditions. During this type of maneuver, vertical and lateral load factors must not exceed 2.5 and 0.8, respectively, as limited by a) strength of the wing rear spar and b) internal stresses in the fuselage.

Elastic loads calculations reflected consideration only of wing flexibility, which was found to be relatively stiff in the symmetrical mode and relatively flexible in the anti-symmetrical mode. However, the structural effect of this latter characteristic is somewhat conservative in that aileron flexibility (aileron "wind-up") relevant to the wing and flexibility in control linkage were not considered and an ensuing load relieving effect would, in reality, be realized.

Aeroelastic degradation with respect to the elasticized stability derivations was primarily a result of aft fuselage bending flexibility and wing flexibility, due to aileron-induced loading. For example, aileron effectiveness, although partially compensated by reduced roll damping, was reduced 24% and 11% at a Mach 0.755 for altitudes of sea level and 20,000 feet, respectively. Other significant results for the most critical flight condition (500 knots at sea level) corresponded to a 22% loss in empennage static longitudinal stability (aft cg referenced) and a similar 32% loss in elevator effectiveness. In comparison, directional stability and control losses were minor.

Principal results with respect to specific airplane components were:

WING

The critical loading occurred during a rolling pull-out maneuver when the vertical load factor exceeded 2.5. However, actual design load had been previously established by a critical symmetrical pull-up maneuver: Mach = 0.8, $q = 850$ psf, $n_z = 4.0$.

FUSELAGE

No one condition dictated fuselage design. However, design loads could be exceeded during certain unlimited rolling pull-out maneuvers, yet could be avoided at all flight conditions when the combined vertical and lateral load factors are prevented from exceeding 2.5 and 0.8 respectively. Although other lateral loading conditions exceed $n_y = 0.8$ (e.g., $n_y = 0.9$ for lateral gust), these were found to be either tolerable or non-critical.

HORIZONTAL TAIL

Two symmetrical maneuvers produced critical design loading. Shear and bending were maximized by a push-over maneuver ($M = 0.8$, $q = 850$ psf, $n_z = -2.0$) while maximum torsion occurred during a pull-up maneuver ($M = 0.28$, sea level, $n_z = 4.0$). In addition, a lateral gust condition produced the maximum rolling moment (couple) at the horizontal/vertical tail juncture.

VERTICAL TAIL

Two flight conditions produced critical design loading. Shear and bending were maximized by a lateral gust condition, whereas a "rudder-kick" maneuver ($M = 0.397$ at sea level) produced maximum torsion.

2.0 INTRODUCTION

This report presents a description of the loads analysis and a compendium of the calculated structural design loads for the U.S. Army XV-5A Lift Fan Research Aircraft. The XV-5A is a V/STOL aircraft designed for research flight testing of the General Electric X353-5 lift fan propulsion system. The structural design criteria (Reference 1) together with the material herein form the basis of the aircraft structural design geometrically illustrated in Figures 2.1 and 2.2.

The XV-5A also features high-subsonic conventional flight operation. It has a basic design gross weight of 9200 pounds, a limit dive speed of 500 KEAS ($q = 850$ psf) and corresponding 0.90 maximum Mach number.

The text of this report is sub-divided into two main parts, presented in Sections 3.0 and 4.0 of the report. Section 3.0 provides a summary of employed methods of analysis whereas final results or design loads (limit values) derived therefrom are presented in Section 4.0. Tables, graphs and other illustrated material immediately follow the text for each subsection.

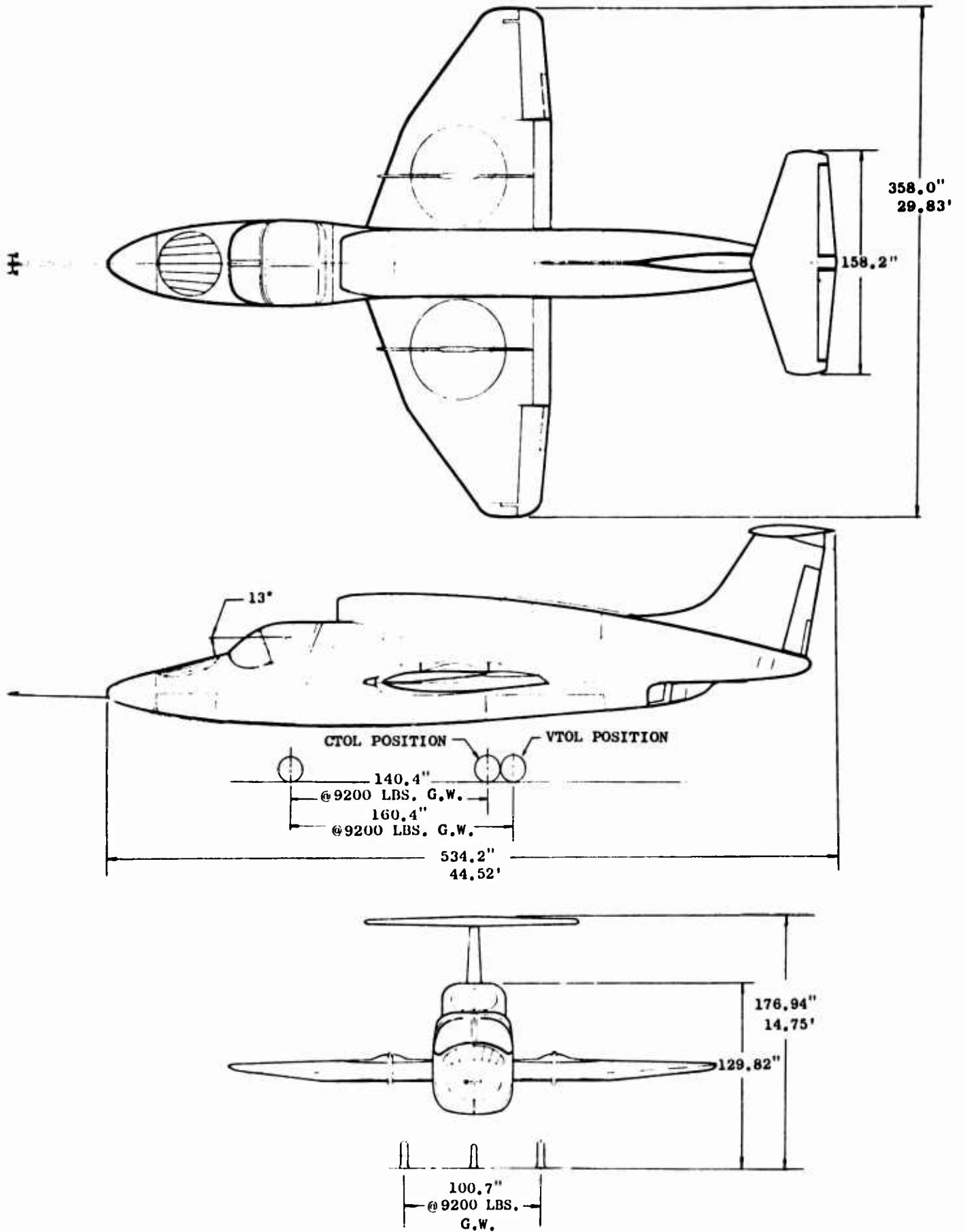
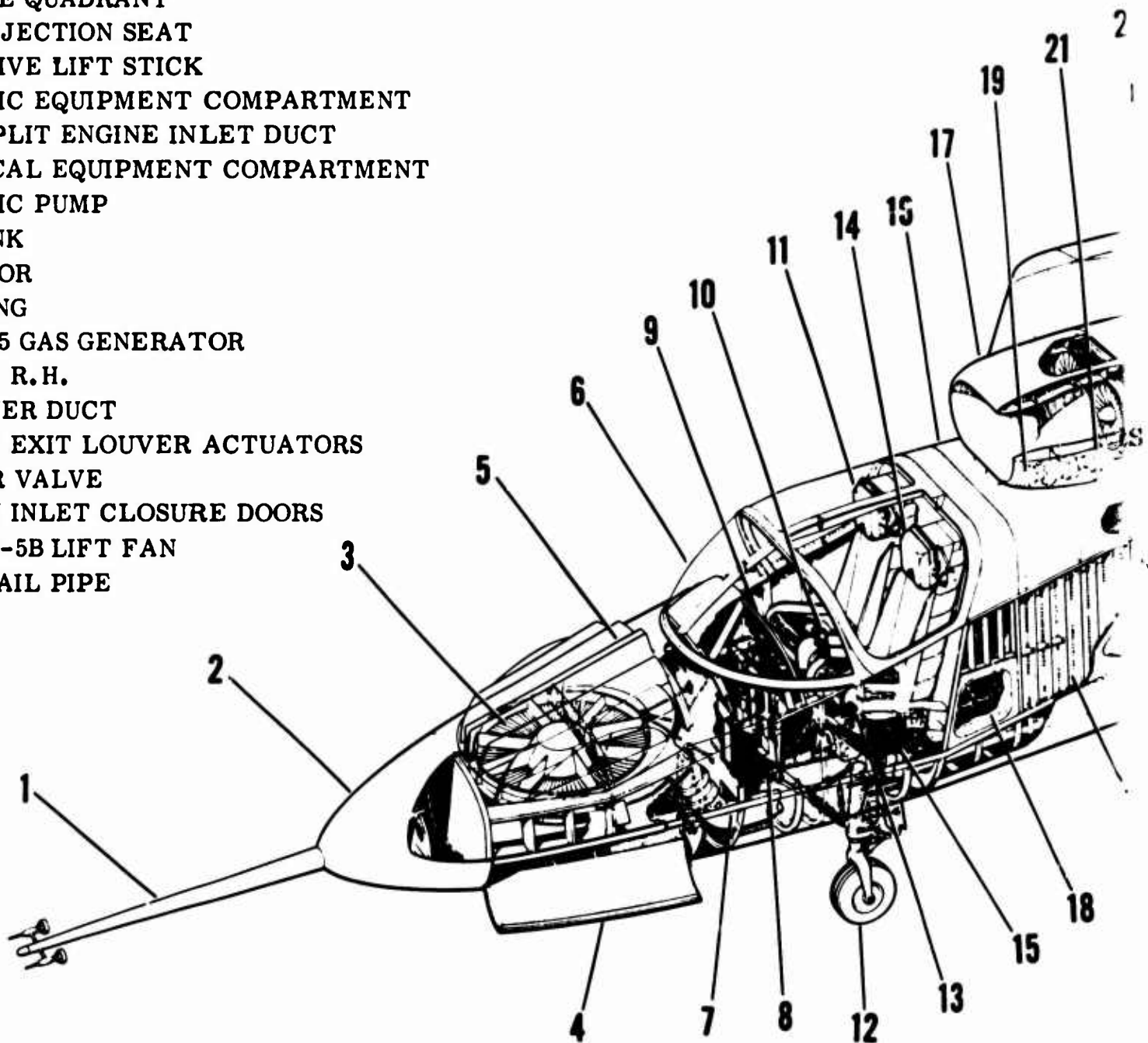

Figure 2.1 Three View - XV-5A

1. PITOT MAST
2. FIBERGLAS NOSE CONE
3. G. E. X376 PITCH FAN
4. NOSE FAN THRUST CONTROL DOOR
5. NOSE FAN INLET CLOSURE DOORS
6. CANOPY
7. NOSE FAN SUPPLY DUCT
8. RUDDER PEDALS
9. INSTRUMENT PANEL
10. CONVENTIONAL CONTROL STICK
11. OBSERVER'S EJECTION SEAT
12. NOSE LANDING GEAR
13. THROTTLE QUADRANT
14. PILOT'S EJECTION SEAT
15. COLLECTIVE LIFT STICK
16. HYDRAULIC EQUIPMENT COMPARTMENT
17. SINGLE SPLIT ENGINE INLET DUCT
18. ELECTRICAL EQUIPMENT COMPARTMENT
19. HYDRAULIC PUMP
20. FUEL TANK
21. GENERATOR
22. RIGHT WING
23. G. E. J85-5 GAS GENERATOR
24. AILERON, R. H.
25. CROSS-OVER DUCT
26. WING FAN EXIT LOUVER ACTUATORS
27. DIVERTER VALVE
28. WING FAN INLET CLOSURE DOORS
29. G. E. X353-5B LIFT FAN
30. ENGINE TAIL PIPE
31. TWO POSITION MAIN LANDING GEAR
32. LEFT WING
33. AILERON L. H.
34. WING FLAP, L. H.
35. THRUST SPOILER, L. H.
36. EXTERNAL LONGERON
37. VERTICAL FIN
38. FULL MOVEABLE HORIZONTAL STABILIZER
39. ANTI-SPIN AND DRAG CHUTE COMPARTMENT
40. RUDDER
41. ELEVATORS



A

- 31. TWO POSITION MAIN LANDING GEAR
- 32. LEFT WING
- 33. AILERON L.H.
- 34. WING FLAP, L.H.
- 35. THRUST SPOILER, L.H.
- 36. EXTERNAL LONGERON
- 37. VERTICAL FIN
- 38. FULL MOVEABLE HORIZONTAL STABILIZER
- 39. ANTI-SPIN AND DRAG CHUTE COMPARTMENT
- 40. RUDDER
- 41. ELEVATORS

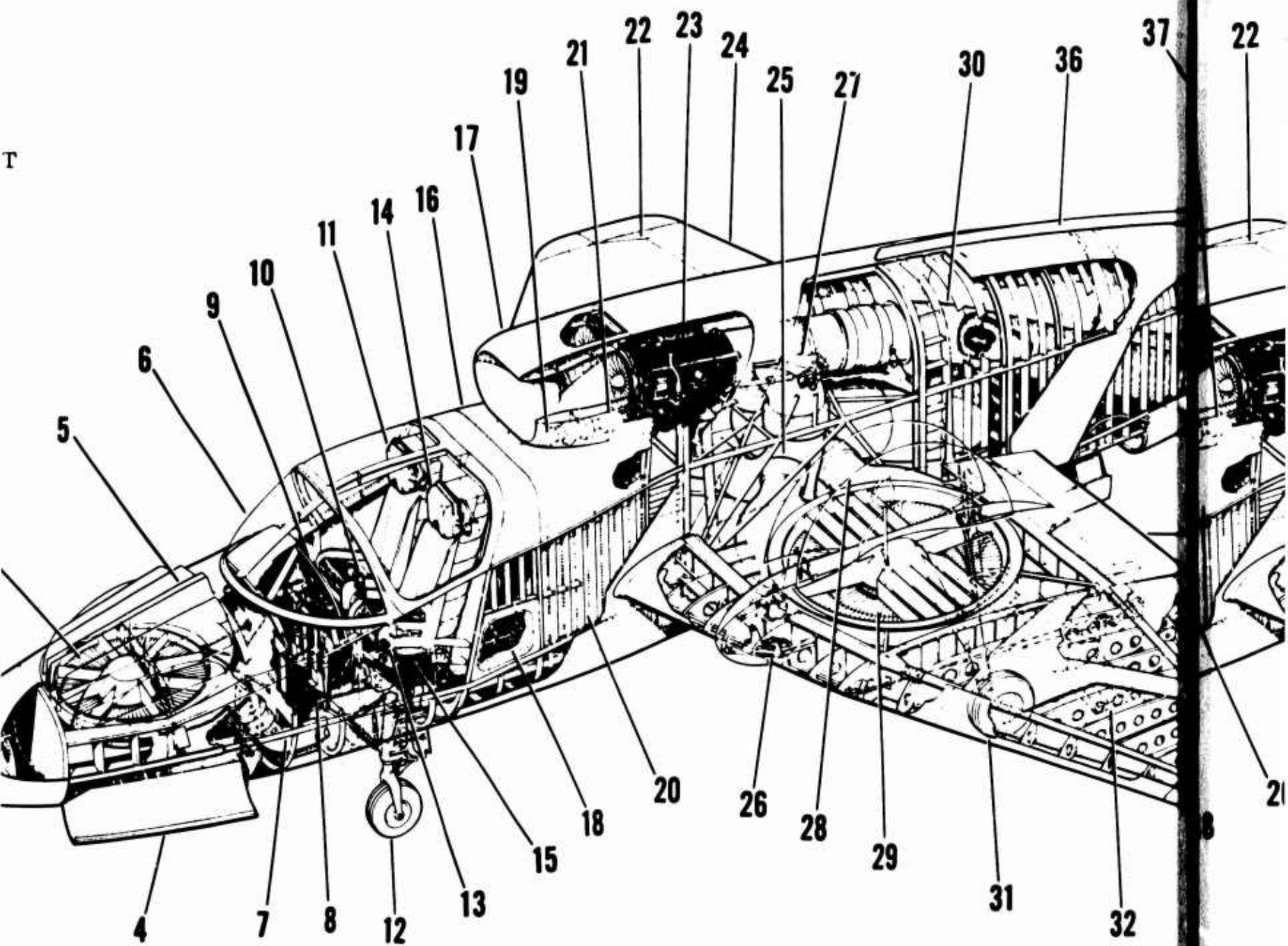

Figure 2.2 Cuta

B

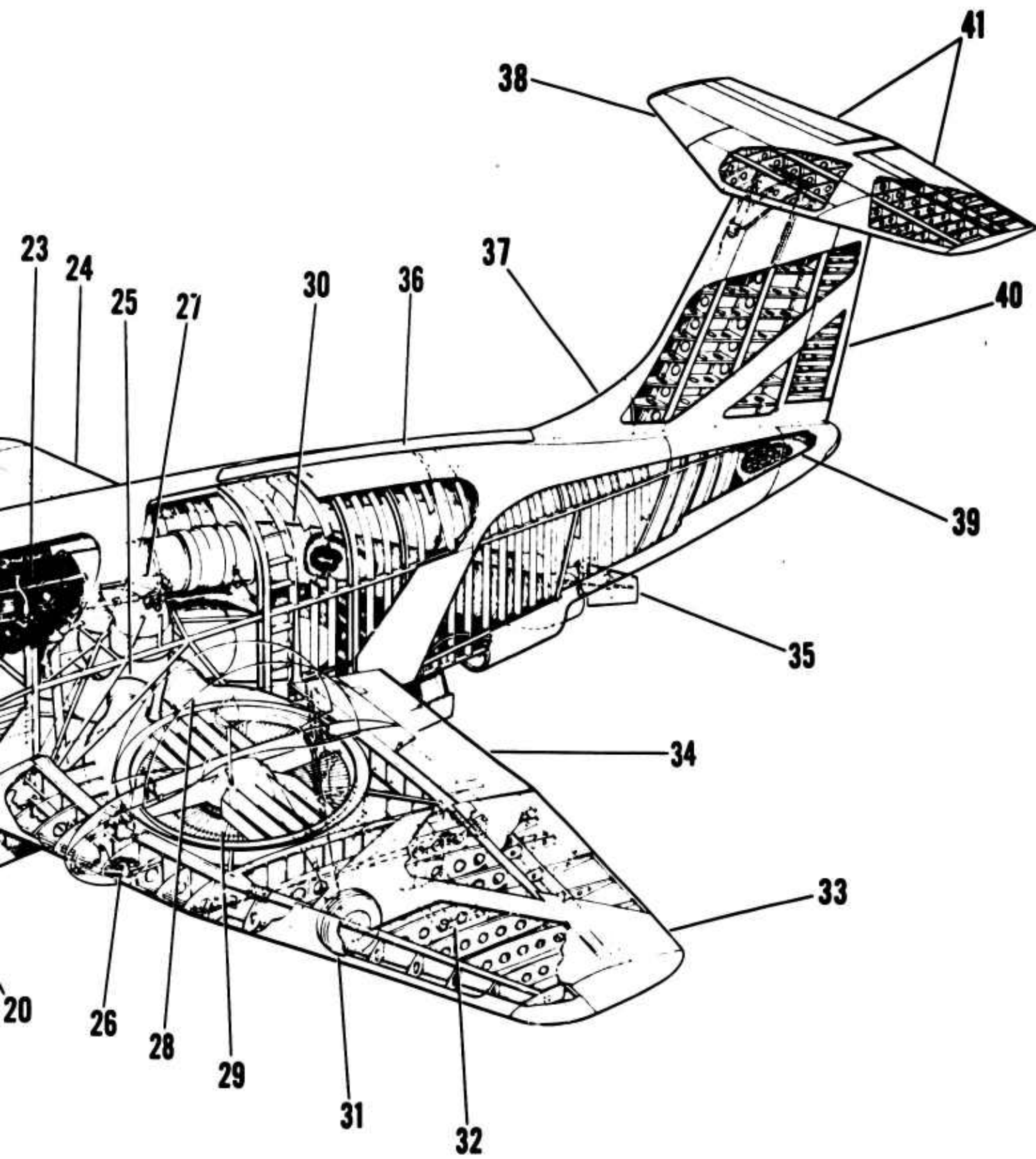

Figure 2.2 Cutaway Drawing - XV-5A

C

3.0 METHOD OF APPROACH

3.1 GENERAL

The loads analysis consisted of evaluation of various loading conditions within specific environmental and functional restraints (Reference 1), and in some instances, evaluation of the influence on structural design. This required the determination of the integrated effect of aerodynamic, propulsive, all other non-aerodynamic, and inertial forces, and then corresponding decomposition of these forces to derive component loads throughout the airframe.

For some conditions (e. g. 4g symmetrical maneuver), total design load on the airplane was directly established by the structural criteria. However, for others (e. g. rolling pull-out maneuver) it was necessary to analyze specified maneuvers to determine the design load resulting as a consequence of the calculated dynamic conditions incurred during the maneuver.

Wind-tunnel test data (References 2 through 4) were utilized extensively throughout the analysis together with current calculated and/or actual distributions of airplane mass.

The design cg limits were treated invariant with airplane weight and representation thereof was artificially effected. The 9200 lb. basic design gross weight was used throughout the analysis. Adequate structural integrity was assumed adequate for all greater gross weights when, in accordance with the design criteria, a constant nW product is maintained.

Principal techniques employed in the analysis and related considerations reflected in final results are presented in the following sub-sections.

3.1.1 Pitching Maneuvers

Maneuvers of this type are characterized by aircraft loading produced by displacement of the cockpit longitudinal control to attain a pre-established vertical load factor. The design maneuvering envelope and associated flight parameters are presented in Figures 3.1 and 3.2.

Since the dynamic state of the airplane is defined by the above, it then was necessary to place the applied forces in equilibrium with inertial forces and parametrically evaluate the effects of speed, altitude, cg, power, etc. Therefore, to "balance" the airplane and therefore determine the primary subdivision of loading between wing, body and tail, a system of equations were derived to determine:

1. Trim angle of attack for unaccelerated level flight assuming zero elevator deflection whereas trim is achieved by tail incidence and subsequently
2. Equilibrium angle of attack which produces specific linear and angular (assumes both zero and finite value) accelerations and angular rate.
3. Subdivision of loading among the primary aircraft components for above items (1) and (2).

To facilitate solution of the equations and thereby afford broad parameter investigation, an IBM 704 Digital Computer was employed. Although the equations were developed on the basis of a stability axis system which thereby assumes a negligible variance from an ideal body axis system, artificial derivatives were utilized to provide realistic solutions for the high speed stall conditions. Iterative calculations were required for the solution of the high speed stall conditions because of non-linear aerodynamic derivatives. The dynamic $C_{L_{max}}$ was considered 1.25 times the static value for the high speed stall conditions.

For the static trim state, lift and pitching moment equations in terms of coefficients are

$$0 = C_{m_{TH}} + (C_{m_{oL}})_{m-t} + (C_{m_{\alpha}})_{m-t} \left[(\alpha)_{trim} - (\alpha_{oL})_{m-t} \right] + (C_{L_{HT}})_{trim} \left(l_{HT}/\bar{c} \right) \quad (1)$$

and

$$0 = C_{L_{TH}} + (C_{L_{\alpha}})_{m-t} \left[(\alpha)_{trim} - (\alpha_{oL})_{m-t} \right] + (C_{L_{HT}})_{trim} - W/qS, \quad (2)$$

$$\text{where } C_{m_{TH}} = M_{Thrust} / qS\bar{c}, \quad (3)$$

$$C_{L_{TH}} = L_{Thrust} / qS, \quad (4)$$

and

$$l_{HT}/\bar{c} = \left[(C_{m_\alpha})_{cm} - (C_{m_\alpha})_{m-t} \right] + \left[(C_{L_\alpha})_{cm} - (C_{L_\alpha})_{m-t} \right] \quad (5)$$

From the above, explicit equations for trimmed tail lift coefficients and angle of attack can be derived and are as follows:

$$(C_{L_{HT}})_{trim} = \frac{(C_{m_{OL}})_{m-t} + (C_{m_{TH}}) + (C_{m_\alpha}/C_{L_\alpha})_{m-t} \left[(W/qS) - C_{L_{TH}} \right]}{(C_{m_\alpha}/C_{L_\alpha})_{m-t} - (l_{HT}/\bar{c})} \quad (6)$$

and

$$(\alpha)_{trim} = (\alpha_{OL})_{m-t} + \frac{\left[(W/qS) - C_{L_{TH}} - (C_{L_{HT}})_{trim} \right]}{(C_{L_\alpha})_{m-t}} \quad (7)$$

Similar to Equations (1) and (2), lift and pitching moment equations for the dynamic state, in terms of coefficients are:

$$0 = (C_{m_\alpha})_{cm} \Delta\alpha + C_{m_{\delta_e}} \delta_e - I_{yy} \ddot{\theta} / qS\bar{c} + (C_{m_q})_{cm} (\dot{\theta}\bar{c}/2V) \quad (8)$$

and

$$0 = (C_{L_\alpha})_{cm} \Delta\alpha + C_{L_{\delta_e}} \delta_e + (C_{L_q})_{cm} (\dot{\theta}\bar{c}/2V) - (n_z - 1) W/qS \quad (9)$$

Simultaneous solution of the above for the required change in angle of attack, $\Delta\alpha$, and corresponding equilibrium elevator deflection, δ_e , yield:

$$\Delta\alpha = \frac{(n_z - 1) W/qS - C_{L_{\delta_e}} \delta_e - (C_{L_q})_{cm} (\dot{\theta}\bar{c}/2V)}{(C_{L_\alpha})_{cm}} \quad (10)$$

and

$$\delta_e = \frac{L_{yy} \ddot{\theta}/qS\bar{c} + \dot{\theta}\bar{c}/2V \left[(C_{m_\alpha}/C_{L_\alpha})_{cm} - (C_{m_q})_{cm} \right]}{C_{m_{\delta_e}} - (C_{m_\alpha}/C_{L_\alpha})_{cm} (C_{L_{\delta_e}})} - \frac{\left[(n_z-1) (C_{m_\alpha}/C_{L_\alpha})_{cm} (W/qS) \right]}{C_{m_{\delta_e}} - (C_{m_\alpha}/C_{L_\alpha})_{cm} (C_{L_{\delta_e}})} \quad (11)$$

Incremental tail lift coefficients are then determined by:

$$(\Delta C_{L_{HT}})_{\delta_e} = C_{L_{\delta_e}} \delta_e, \quad (12)$$

$$(\Delta C_{L_{HT}})_{\Delta\alpha} = \left[(C_{L_\alpha})_{cm} - (C_{L_\alpha})_{m-t} \right] \Delta\alpha, \quad (13)$$

and

$$(\Delta C_{L_{HT}})_{\dot{\theta}} = (C_{L_q})_{HT} (\dot{\theta}\bar{c}/2V) \quad (14)$$

where

$$(C_{L_{HT}})_{total} = (C_{L_{HT}})_{trim} + \sum (\Delta C_{L_{HT}}) \quad (15)$$

Also

$$(C_{L_{m-t}})_{total} = n_z W/qS - (C_{L_{HT}})_{total}, \quad (16)$$

$$(C_{L_{B(W)}})_{total} = (C_{L_\alpha})_{B(W)} \left[(\alpha)_{trim} + \Delta\alpha - (\alpha_{OL})_{B(W)} \right], \quad (17)$$

and

$$(C_{L_{W(B)}})_{total} = (C_{L_{m-t}})_{total} - (C_{L_{B(W)}})_{total} \quad (18)$$

Total aerodynamic pitching moment coefficients for the wing and body components are

$$\begin{aligned} (C_{m_{B(W)}})_{\text{total}} &= (C_{m_{OL}})_{B(W)} + (C_{m_{\alpha}})_{B(W)} \left[(\alpha)_{\text{trim}} \right. \\ &\quad \left. + \Delta\alpha - (\alpha_{OL})_{B(W)} \right] \end{aligned} \quad (19)$$

and

$$\begin{aligned} (C_{m_{W(B)}})_{\text{total}} &= (C_{m_{OL}})_{m-t} - (C_{m_{B(W)}})_{\text{total}} \\ &\quad + (C_{m_{\alpha}})_{m-t} \left[(\alpha)_{\text{trim}} + \Delta\alpha - (\alpha_{OL})_{m-t} \right] \\ &\quad + \left[(C_{m_q})_{cm} - (C_{L_q})_{HT} \ell_{HT}/\bar{c} \right] (\dot{\theta}\bar{c}/2V) \end{aligned} \quad (20)$$

The center of pressure of total horizontal tail lift is

$$x_{cp}/\bar{c}_{HT} = \frac{C_{m_{\delta_e}} \delta_e + \left[(C_{L_{HT}})_{\text{total}} - (\Delta C_{L_{HT}})_{\delta_e} \right] (\ell_{HT}/\bar{c})}{(C_{L_{HT}})_{\text{total}}} \quad (21)$$

In the foregoing equations the combined pitch damping for the wing-body was assumed produced entirely by the wing. Also, contribution of the wing to the wing-body stability coefficients was deduced from integrated wing surface pressure data.

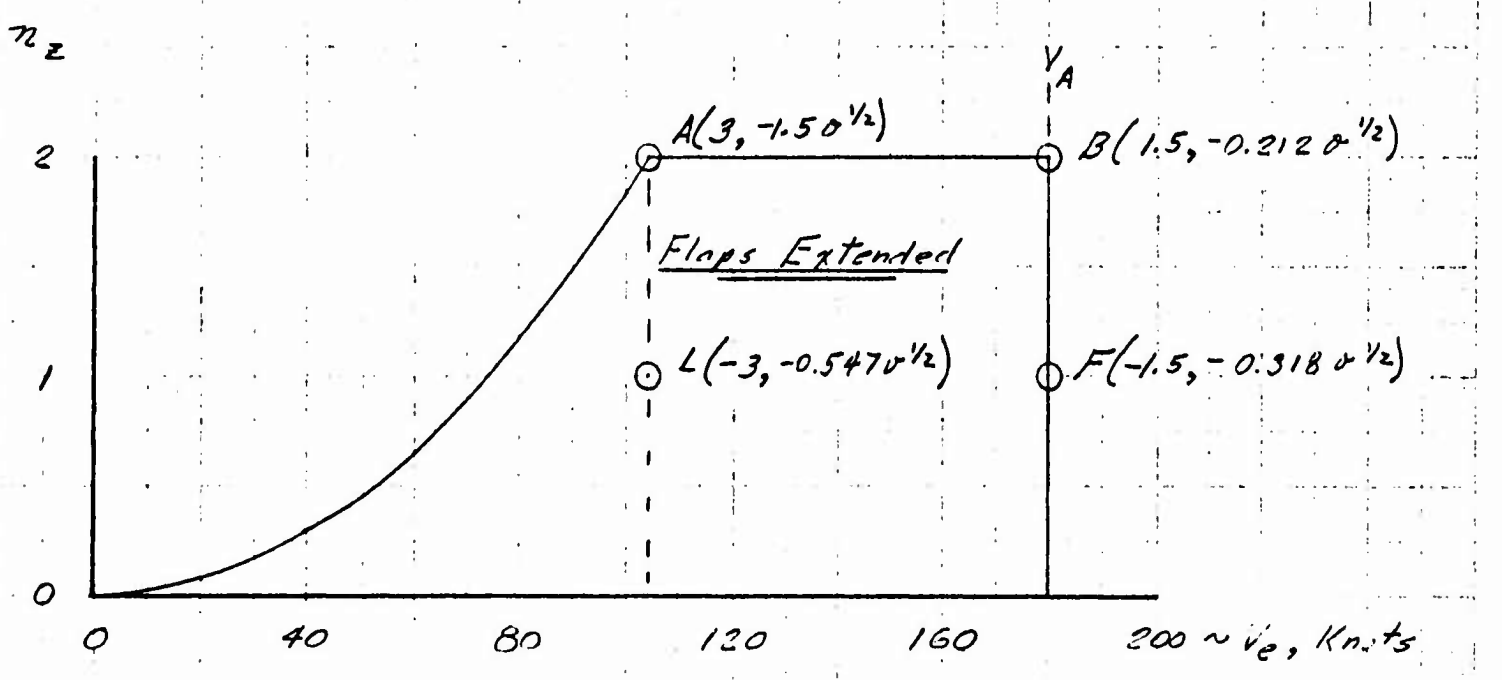
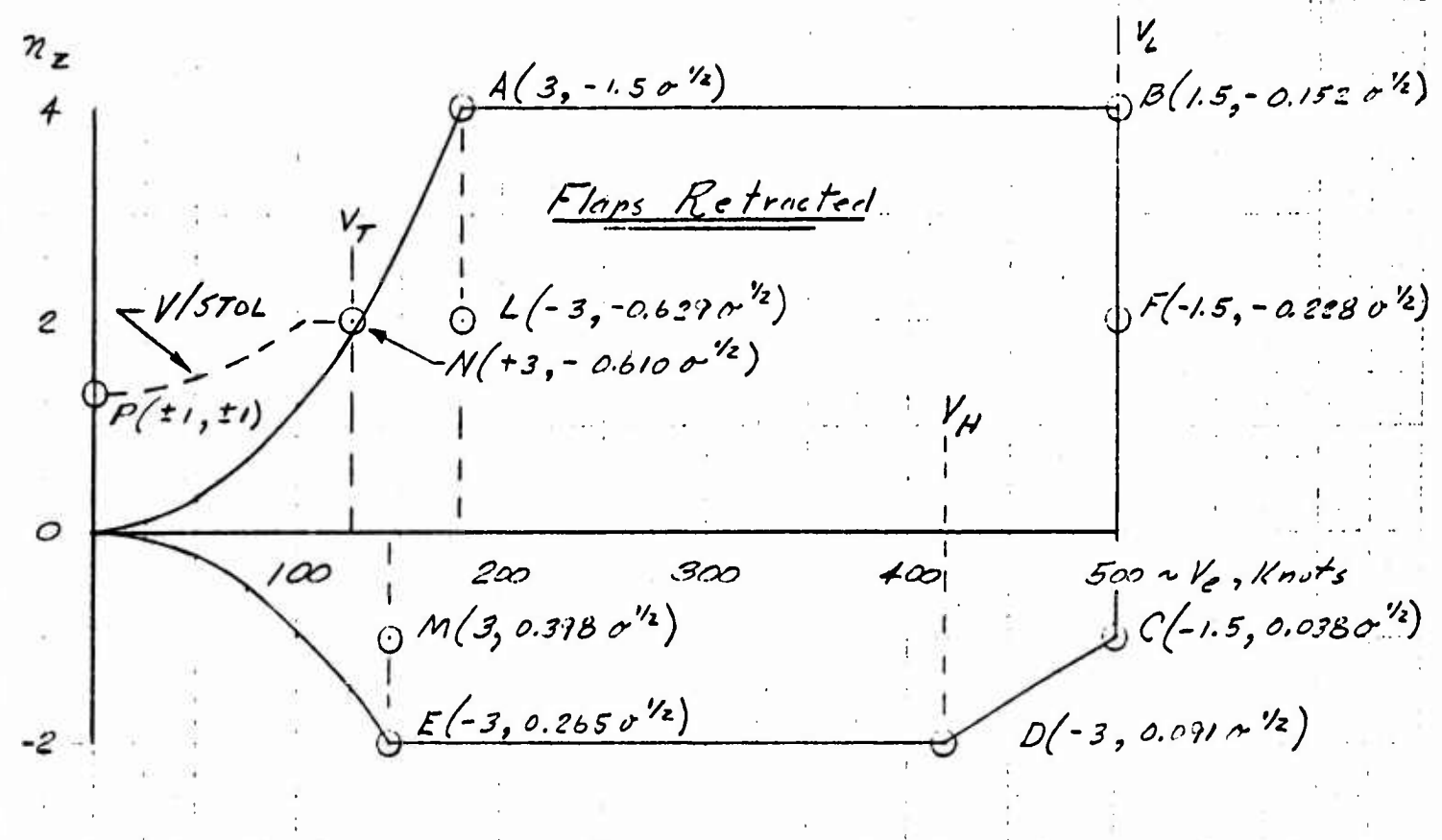

- Note:
- 1) Parenthetical quantities are, respectively, $\dot{\omega}_y$ & $\ddot{\omega}_y$
 - 2) $V_T = 125$ KTAS
 - 3) V_H corresponds to $M \leq 0.85$
 - 4) V_L " " $M \leq 0.90$

Figure 3.1 V-n Diagram

Altitude $\cdot 10^{-3}$, ft.

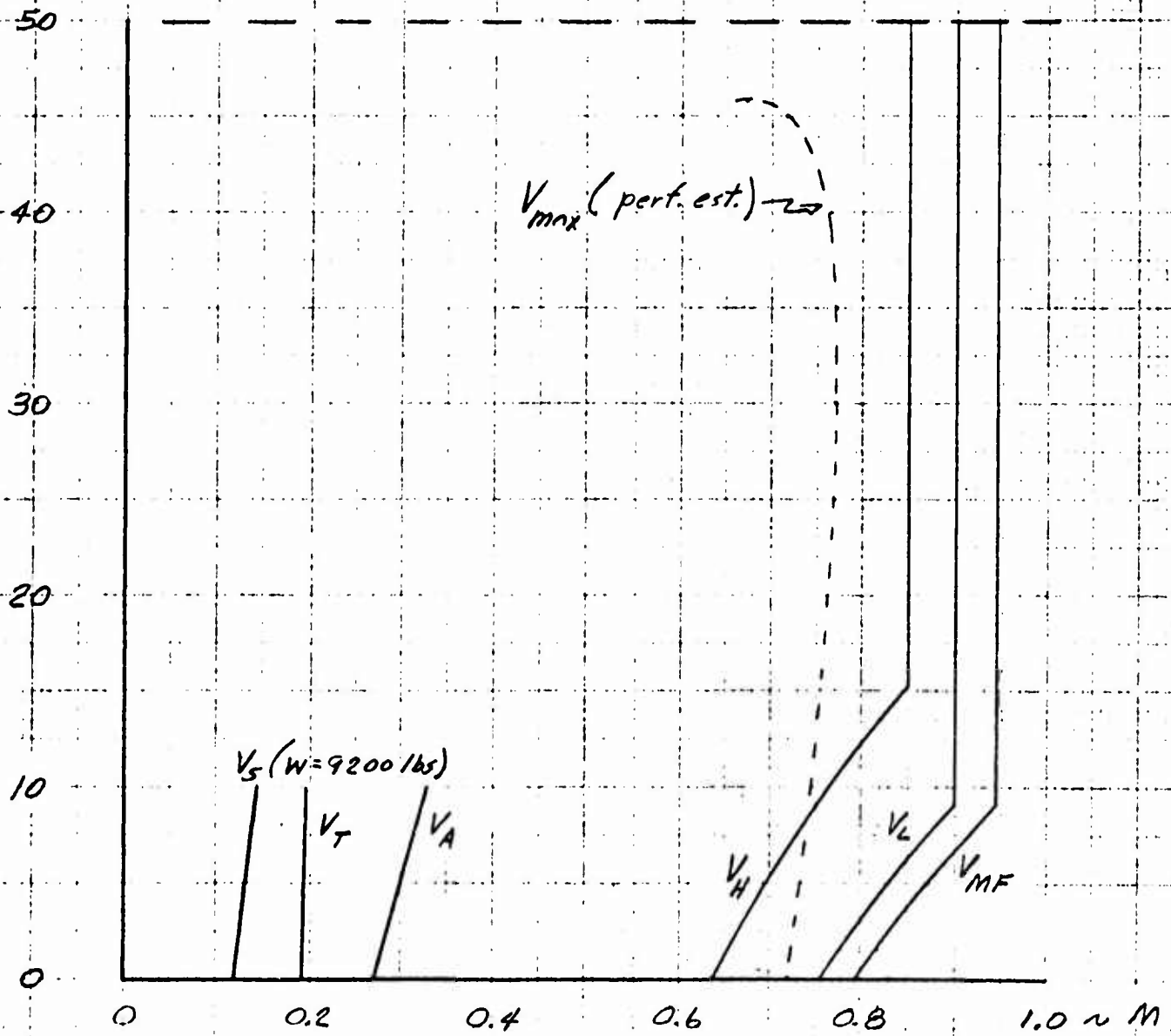

Figure 3.2 Design Mach No. - Altitude Envelope

3.1.2 Rolling Maneuvers

Roll maneuvers were investigated through impulsing the airplane by (1) rapid and (2) maximum possible movement of the cockpit lateral control such that specific motion and/or attitude displacement in accordance with the procedures and limitations prescribed by the Structural Design Criteria were produced. Item (2) corresponds to "steady-state" rolls and item (1) is related to the classic "rolling pull-out" maneuver.

For the rolling pull-out analysis, the characteristic motion in the anti-symmetrical or lateral-directional mode was determined separately from the symmetrical or longitudinal mode, and subsequently the results were super-imposed for representation of the net unsymmetrical loading condition. Vertical load factor, n_z , was assumed constant during the maneuver and corresponded, respectively, to values of 1.0 and up to and including 3.0 for "flaps-down" and "flaps-up" configurations. Wing loads were primarily dependent on angle of attack, roll rate, roll acceleration and corresponding aileron deflection. Since load factor, and therefore angle-of-attack, were held constant, a simplified one-degree of freedom analysis was employed. At a later date a digital program afforded a more complete three-degrees of freedom simulation which was necessitated by the significance of cross-coupling effects on fuselage and empennage loading.

In the following sub-sections the mechanics of both methods of analysis are presented.

3.1.2.1 Simplified Analysis

Assuming aileron rate to be a constant during any particular time interval and neglecting 2nd order terms, the following equations were assumed to approximate motion in roll:

$$\dot{p} = K_{\delta_A} (\delta_{A_0} + \dot{\delta}_{A_t}) + K_p p \quad (1)$$

Since this equation is of the form ...

$$\dot{y} = Q - Py \quad (2)$$

whose general solution is ...

$$y = e^{-\int P dx} \left(\int Q e^{\int P dx} + C_e \right) = \int P dx, \quad (3)$$

it follows ...

$$p = \frac{K_{\delta} \dot{\delta}_A}{K_p^2} \left[\exp(K_p t) - 1 \right] - \frac{K_{\delta} \delta_A}{K_p} (\delta_{A_0} + \dot{\delta}_A t) \quad (4)$$

Or, in terms of δ_A :

$$p = \frac{K_{\delta} \dot{\delta}_A}{K_p^2} \left\{ \exp \left[K_p \frac{\delta_A - \delta_{A_0}}{\dot{\delta}_A - 1} \right] \right\} - \frac{K_{\delta} \delta_A}{K_p} (\delta_A) \quad (5)$$

It can be shown by the above equation for $\delta_A = \delta_{A_0}$ or by Equation (1) for $\dot{p} = 0$, that equilibrium or steady-state roll rate is:

$$p_{SS} = - \frac{K_{\delta} \delta_A}{K_p} (\delta_{A_0}) \quad (6)$$

In order to utilize the above equations, it was necessary to determine suitable values of aileron rate. The lateral control system consisted of a servo tab, hydraulic boosted network whose maximum output provided an aileron rate (referenced to total aileron deflection) of $425^\circ/\text{s}$. However, during realistic operation, output rate was dependent on the relative position of the control stick (or tab) and aileron, ... and opposing aerodynamic hinge moments. The derived representative rate equations are:

$$\dot{\delta}_A = A \epsilon (\dot{\delta}_A)_{\max.} \sqrt{B}, \quad |\delta_A| \rightarrow 0 \quad (7)$$

and

$$\dot{\delta}_A = A \epsilon (\dot{\delta}_A)_{\max.} \sqrt{BC \left(1 - \frac{\delta_A}{\delta_{A_{\max.}}} \right)}, \quad \delta_A \rightarrow (\delta_A)_{\max.} \quad (8)$$

Use of the above equation (7) for, typically, an abrupt left roll "check" assumed a step-input of the control stick and consequently ...

$$\dot{\delta}_A = (\dot{\delta}_A)_{\max.} \quad (9)$$

As δ_A continued beyond neutral, the error value, ϵ , was maintained constant ($\epsilon_{\max.} = 0.45''$) until full stick travel (5'') had been attained. Thereafter, ϵ was assumed linearly diminishing to zero at full aileron deflection. The resultant profile is shown in Figure 3.3 for both (1) low-speed flaps-down and (2) high-speed flaps-up configurations.

It should further be noted that when aileron rate varied with time, or more appropriately aileron position, an iterative solution was employed.

3.1.2.2 Three-Degrees of Freedom Solution

The transient lateral-directional motion of the airplane during various roll maneuvers was represented by three-degrees of freedom which corresponded to the interacted motions in roll (\dot{p}), yaw (\dot{r}) and lateral displacement ($V\dot{\beta}$). In addition, a number of auxiliary equations were derived to simulate pilot/control system response characteristics. The combined equations were then mechanized for digital computer solution to provide a time history of events. Although this method primarily served as a means of evaluating the "Rolling Pull-out Maneuver", it also enabled examination of the inherent characteristic lateral motion during "steady-state" rolls.

The type of rolling pull-out maneuver which was investigated consisted of rolling the airplane out of a constant altitude turn through an angle equal to twice the initial bank angle, maintaining zero rudder deflection and assuming vertical load factor to remain constant. Execution of the maneuver was by rapid displacement (from neutral) of the cockpit lateral control and subsequently "checking" the roll by rapid reversal of the cockpit lateral control. The applicable initial bank angle corresponded to the relationship: $\cos \varphi = \pm (1/n_z)$ for various values of n_z up to and including the maximum design condition. Aileron deflection and rate were the maximum attainable commensurate with a 60 pound stick force and pilot application (neutral to maximum and full left to full right) time of 0.1 second.

The derived control system equations which were found representative of the specified pilot reaction and maximum attainable output rates of Figure 3.4 are as follows:

Roll Execution

For $0 < t \leq 0.1''$,

$$\delta_A = 12.2173 t^{1.6} \sim \text{radians, typical} \quad (1)$$

and for $0.1'' < t \leq t_{\text{check}}$,

$$\delta_A = 0.59341 - 1.46084 \exp(-16.27 t) \quad (2)$$

Roll "Check"

For $t_{\text{check}} < t \leq (t_{\text{check}} + 0.048'')$,

$$\begin{aligned} \delta_A = & -0.58364 \exp [20.33493 (t_{\text{check}} - t)] \\ & + 11.86824 (t_{\text{check}} - t) + 1.17705 \end{aligned} \quad (3)$$

For $(t_{\text{check}} + 0.048'') < t \leq (t_{\text{check}} + 0.131'')$

$$\delta_A = 7.41765 (t_{\text{check}} - t) + 0.74334 \quad (4)$$

and for $(t_{\text{check}} + 0.131'') < t$,

$$\delta_A = 5.27089 \exp [20.33493 (t_{\text{check}} - t)] - 0.59341 \quad (5)$$

With respect to a body axis system (and implied appropriate stability derivatives), the employed airframe equations of motion are:

$$\begin{aligned} \dot{\beta} = & (g/V) \sin \varphi + C_1 p + C_2 r \\ & + (qS/mV) \left[C_{y_{\delta_A}} \delta_A + C_{y_{\beta}} \beta \right] \end{aligned} \quad (6)$$

$$\begin{aligned} \dot{p} = & (qSb/I_{xx}) \left\{ C_{l_{\delta_A}} \delta_A + C_{l_{\beta}} \beta + (b/2V) [C_{l_r} r + C_{l_p} p] \right\} \\ & + (I_{xz}/I_{xx}) \dot{r} \end{aligned} \quad (7)$$

$$\dot{r} = C_4 \delta_A + C_5 \beta + C_6 r + C_7 p \quad (8)$$

Where

$$C_1 = \alpha + (qSb/2mV^2) (C_{y_p}) \quad (9)$$

$$C_2 = (qSb/2mV^2) (C_{y_r}) - 1 \quad (10)$$

$$C_3 = (qSb) (I_{xx}) / (I_{xx} I_{zz} - I_{xz}^2) \quad (11)$$

$$C_4 = C_3 \left[C_{n_{\delta_A}} + (I_{xz} / I_{xx}) C_{l_{\delta_A}} \right] \quad (12)$$

$$C_5 = C_3 \left[C_{n_{\beta}} + (I_{xz} / I_{xx}) C_{l_{\beta}} \right] \quad (13)$$

$$C_6 = C_3 (b/2V) \left[C_{n_r} + (I_{xz} / I_{xx}) C_{l_r} \right] \quad (14)$$

$$C_7 = C_3 (b/2V) \left[C_{n_p} + (I_{xz} / I_{xx}) C_{l_p} \right] \quad (15)$$

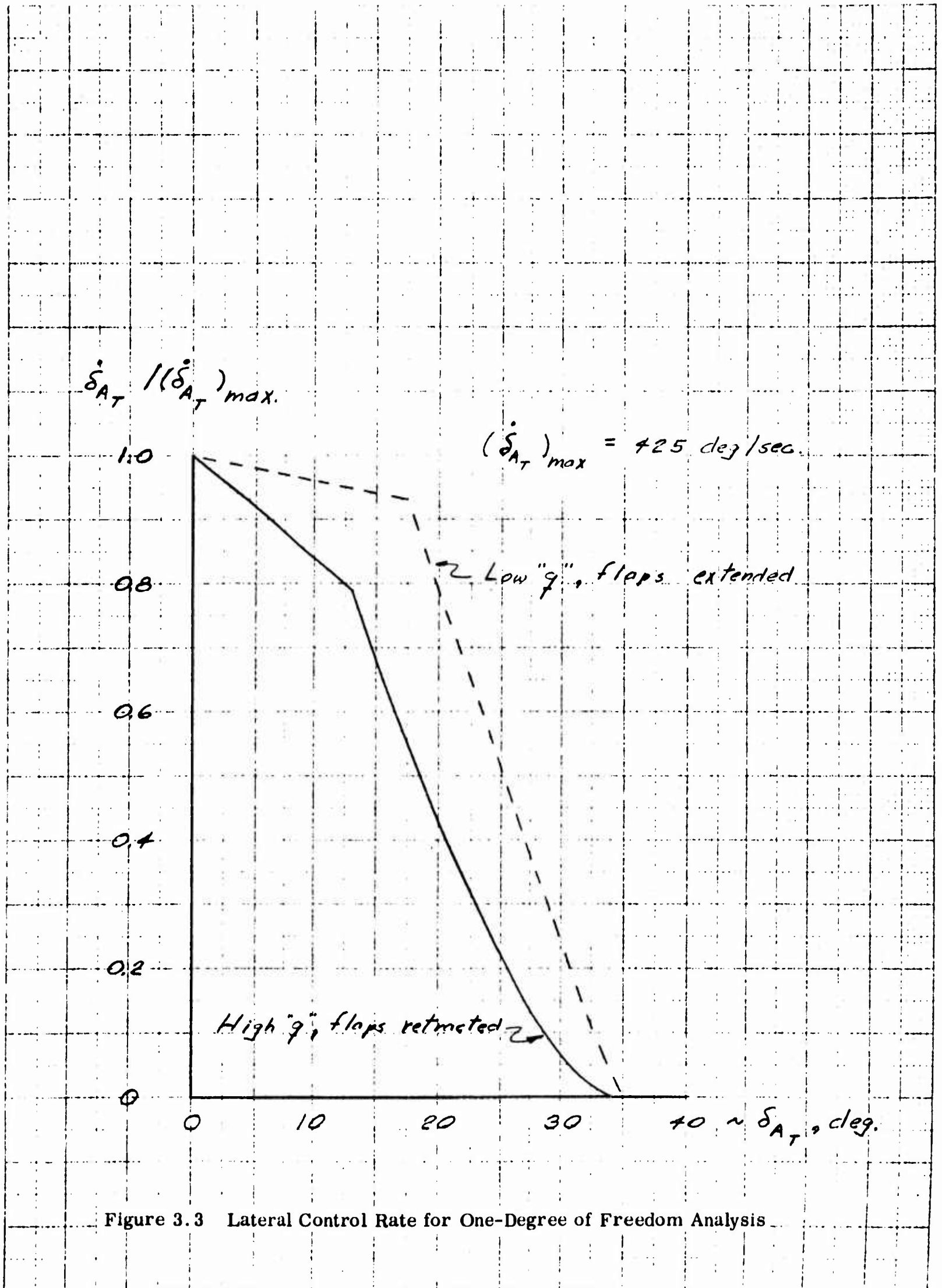

Figure 3.3 Lateral Control Rate for One-Degree of Freedom Analysis

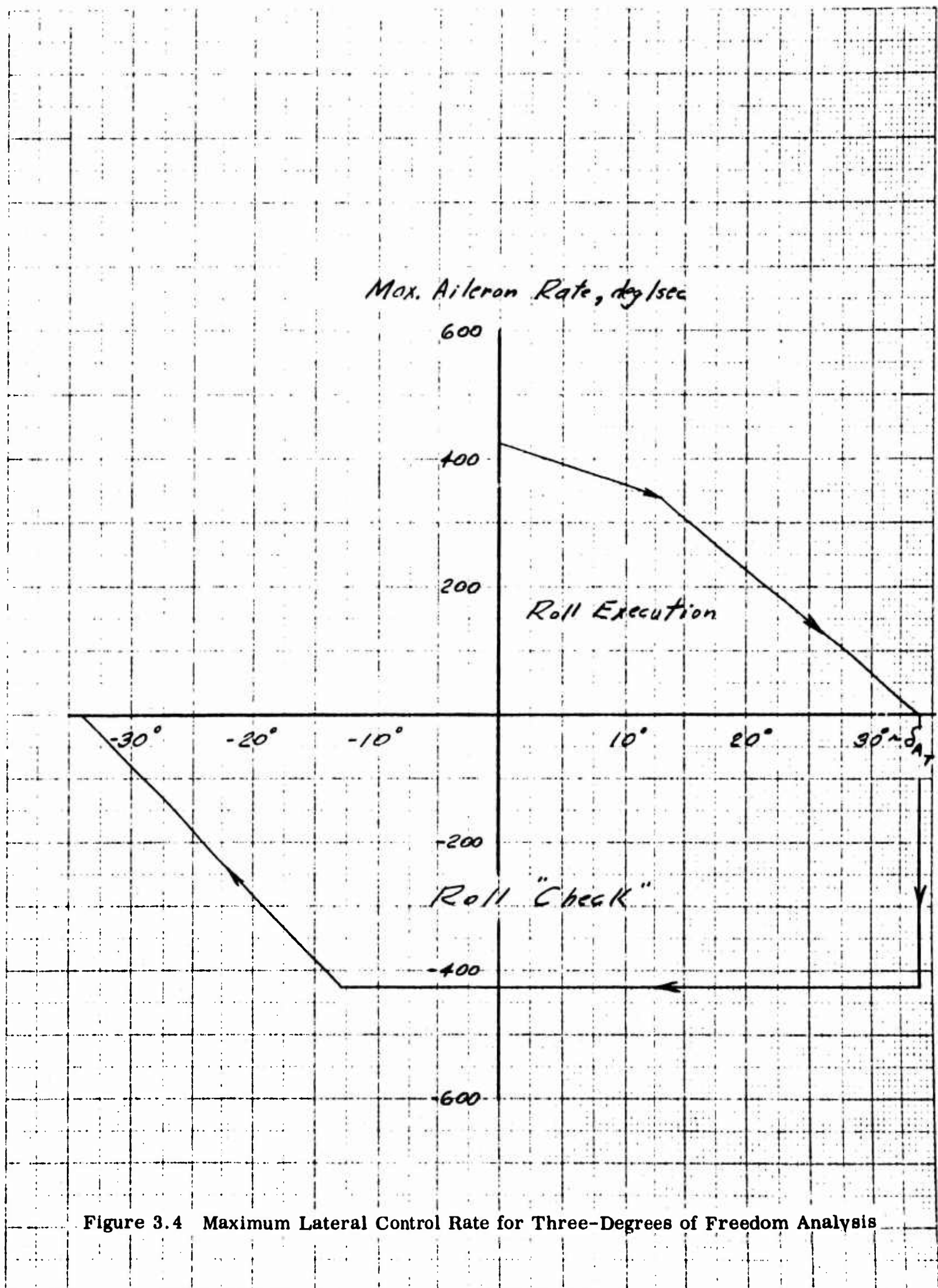

Figure 3.4 Maximum Lateral Control Rate for Three-Degrees of Freedom Analysis

3.1.3 Yawing Maneuvers

An extensive analysis was made to determine structural loading produced by rudder-impulsed yawing maneuvers. As has been the practice, post-superposition of loading within the plane of symmetry, prevailed which, for the present type of maneuver, corresponded to trimmed, 1-g flight.

Two methods of solution were employed which differed from one another, primarily, by the consideration of dynamic over-shoot in side-slip angle, β . Although the design criteria specified a 50% overshoot value above a steady-state condition, further effort was devoted in ascertaining its accuracy. In one case a closed static solution was possible whereas a time-history study revealed the airplane's inherent characteristics. Each of these methods is described in the following subsections.

3.1.3.1 Static Solution

Four (4) distinct rudder-induced yawing conditions were analyzed and are described as follows:

1. A rudder "Kick" maneuver which assumes an instantaneous rudder deflection to the maximum mechanical limits ($\pm 25^\circ$), or as limited by a pilot pedal force of 200 lbs. for speeds greater than $.6 V_H$, or 300 lbs. for lesser speeds. Sideslip and roll angles, and yaw and roll velocities are considered zero. The equations used in defining the maneuver are:

$$\delta_r = (F_r / k q S_r \bar{c}_r) / (C_{h_{r\delta_r}}) \leq |25^\circ| \quad (1)$$

where

F_r = effective pilot effort in pounds

k = rudder gearing ratio = .13426 (lb./in.-lb.)

$$n_y = C_{y_{\delta_r}} (\delta_r) (q S) / W \quad (2)$$

$$\ddot{\phi} = \left[C_{l_{\delta_r}} + \left(\frac{I_{xz}}{I_{zz}} \right) \left(C_{n_{\delta_r}} \right) \right] \left[(\delta_r) (I_{zz} q S b) \right] + \left[I_{xx} I_{zz} - I_{xz}^2 \right] \quad (3)$$

$$\dot{r} = \left[(I_{xz}) (\ddot{\phi}) + \left(C_{n_{\delta_r}} \right) (\delta_r) (q S b) \right] / (I_{zz}) \quad (4)$$

2. A steady-state sideslip maneuver which results from a rudder deflection to the mechanical stops or as limited by a pilot effort of 300 lbs. Zero rolling moments are maintained by aileron deflection. Roll-and-yaw rates and corresponding accelerations are considered zero. The equations used to define the maneuver are:

$$\delta_r = \left(\frac{Fr}{kqSr\bar{c}r} \right) + \left\{ C_{h_{r\delta_r}} + \left(C_{h_{r\beta}} \right) \frac{\left[\left(\frac{C_{l_{\delta_A}}}{C_{n_{\delta_A}}} \right) - \left(C_{n_{\delta_r}} \right) - C_{l_{\delta_r}} \right]}{\left[C_{l_{\beta}} - \left(\frac{C_{l_{\delta_A}}}{C_{n_{\delta_A}}} \right) C_{n_{\beta}} \right]} \right\} \quad (5)$$

$$\delta_A = \delta_r \frac{\left[C_{n_{\beta}} \left(\frac{C_{l_{\delta_r}}}{C_{l_{\beta}}} \right) - C_{n_{\delta_r}} \right]}{\left[C_{n_{\delta_A}} - C_{n_{\beta}} \left(\frac{C_{l_{\delta_A}}}{C_{l_{\beta}}} \right) \right]} \quad (6)$$

$$\beta = - \left[\left(C_{n_{\delta_r}} \right) \delta_r + \left(C_{n_{\delta_A}} \right) \delta_A \right] / C_{n_{\beta}} \quad (7)$$

$$n_y = \left[\left(C_{y_{\beta}} \right) \beta + \left(C_{y_{\delta_r}} \right) \delta_r \right] (q S) / W \quad (8)$$

3. A dynamic-overswing sideslip condition which assumes that during a rudder-induced yawing maneuver, the airplane will attain an "overswing" sideslip angle 50% larger than the steady-state value. The above steady-state sideslip equations are solved for β , considering a pilot effort of 200 lbs. at speeds greater than $.6 V_H$ and 300 lbs. for lesser speeds. The sideslip angle thus obtained is increased by 50% to define the dynamic overswing maneuver. Yaw and roll rates and aileron deflection are considered zero. The rolling and yawing moments and the side forces are balanced by airplane inertia. The equations used in defining the maneuver are:

$$n_y = \left[(C_{y\beta}) \beta + (C_{y\delta_r}) \delta_r \right] (q S) / W \quad (9)$$

$$\ddot{\phi} = \left\{ \left[C_{l\beta} + \left(\frac{I_{xz}}{I_{zz}} \right) (C_{n\beta}) \right] \beta + \left[C_{l\delta_r} + \left(\frac{I_{xz}}{I_{zz}} \right) (C_{n\delta_r}) \right] \delta_r \right\} \left[\frac{I_{zz} q S b}{I_{xx} I_z - I_{xz}^2} \right] \quad (10)$$

$$\dot{r} = \left\{ \left[(C_{n\beta}) \beta + (C_{n\delta_r}) \delta_r \right] q S b + (I_{xz}) \ddot{\phi} \right\} / I_{zz} \quad (11)$$

where the value of δ_r and β are determined from the steady-state equations with the appropriate pilot effort values.

4. A rudder deflection reversal maneuver which assumes that the rudder is instantaneously returned to neutral with the airplane in the steady-state sideslip condition resulting from a 200 lbs. pilot effort for speeds greater than $.6 V_H$ or 300 lbs. for lesser speeds. Yaw and roll rates are again considered zero. Unbalanced moments and forces are balanced by airplane inertia.

The equations used in defining the maneuver are:

$$n_y = (C_{y\beta}) (\beta) (q S) / W \quad (12)$$

$$\ddot{\phi} = \left\{ \left[C_{l\beta} + \left(\frac{I_{xz}}{I_{zz}} \right) (C_{n\beta}) \right] \beta + \left[C_{l\delta_A} + \left(\frac{I_{xz}}{I_{zz}} \right) (C_{n\delta_A}) \right] \delta_A \right\} \left[\frac{I_{zz} q S b}{I_{xx} I_z - I_{xz}^2} \right] \quad (13)$$

$$\dot{r} = \left\{ \left[(C_{n\beta}) \beta + (C_{n\delta_A}) \delta_A \right] q S b + (I_{xz}) \ddot{\phi} \right\} / I_{zz} \quad (14)$$

where the values of β and δ_r are determined from the steady-state equations with the appropriate values of pilot effort.

The equations for the above four rudder-induced maneuvers were programmed for solution by a digital computer. Other equations for solution of airplane component loading (wing, fuselage vertical and horizontal tail, etc.) were also programmed.

3.1.3.2 Dynamic Solution

To determine the validity of increasing the steady-state sideslip angle by 50% to establish the maximum dynamic-overswing sideslip angle from a rudder kick, a time-history study of the maneuver was made by utilization of a three-degrees of freedom lateral/directional digital computer program. The simulated maneuver consisted of; (1) an instantaneous deflection of the rudder to the maximum displacement attainable with a 200 pound pilot effort, (2) maintenance of this pilot effort for 5 seconds until steady sideslip is attained, and (3) instantaneous neutralization of the rudder.

The equations of motion which were solved for the study were identical to those discussed in Section 3.1.2.2 except that all reference to aileron deflection (δ_A) should be changed to rudder deflection (δ_r), and the equation defining the rudder deflection is:

$$\delta_r = \left[\frac{F_r}{k q S r \bar{c}_r} - (C_{h_{r\beta}}) \beta \right] / C_{h_{r\delta_r}} \leq \pm 25^\circ$$

3.2 SPIN RECOVERY

Since the vertical load factor which the airplane is assumed encountering during a "steep" spin is twice that of a "flat" spin, the latter condition was deemed non-critical. Furthermore, the specified "entry speed" is irrelevant in view of the following relationship of the components of angular rate (body axes) with angles of attack and side-slip:

$$p = \Omega \cos \beta \cos \alpha \quad (1)$$

$$q = \Omega \sin \beta \quad (2)$$

$$r = \Omega \cos \beta \sin \alpha \quad (3)$$

From the above equations the appropriate values of α and β were determined for $p = r = \pm 3.5$ rad/sec and $q = +1.0$ rad/sec.

Aerodynamic force derivatives were then estimated and subsequently applied at a velocity which produced the required 2.0-g vertical load factor. This speed, in conjunction with α and β , also enabled the determination of the components of spin chute drag forces. The associated linear/angular accelerations were then whatever resulted from the above for an assumed power-off condition and estimated loading distribution.

3.3 GUST PERTURBATION

The gust spectrum as defined in the design criteria consists of maximum gust intensities, vertically or laterally, of 24 ft/sec at all speeds inclusive of V_L and 40 ft/sec at all speeds inclusive of V_H . The resultant airplane loading was determined on the basis of an incremental change in angle of attack or angle of sideslip beyond a trimmed 1-g flight condition. For a vertical disturbance, an allowance was made for airplane damping during the progressive "build-up" of a gust intensity to its full value. No similar allowances were made for lateral gusts. It should also be noted that gust intensities were treated in terms of true airspeeds.

3.3.1 Vertical Gusts

The incremental change in lift on the airplane as a whole, or locally on the horizontal tail, was a direct result of incremental angle of attack, computed as follows:

$$\Delta\alpha = \pm K \tan^{-1} (V_{\text{gust}} / V) \quad (1)$$

where for the wing or complete airplane

$$K_W = \frac{0.88 \mu}{5.3 + \mu} \quad (2)$$

and

$$\mu = \frac{2 (W/S)}{g c_{av} \rho (C_{L\alpha})_{cm}} \quad (3)$$

For a 9200-lb. airplane, Equation (3) reduces to a function of density ratio, σ , and untrimmed complete-model $C_{L\alpha}$ (per radian):

$$\mu = 105.94 / (C_{L\alpha})_{cm} \sigma \quad (4)$$

When computing a local horizontal-tail load, however,

$$K_{HT} = 1.1 K_W \quad (5)$$

Since the design criteria limited the gust-induced incremental load factor to ± 3.0 (maximum of V-n diagram), it was only necessary to evaluate local horizontal-tail loading.

3.3.2 Lateral Gusts

As a result of the gust velocity, the airplane was assumed instantaneously exposed to the effects of a sideslip angle defined as:

$$\beta_{GUST} = \tan^{-1} \left(\frac{V_{GUST}}{V} \right)$$

A simple lateral/directional static balance of the airplane was performed to determine lateral-gust loading. Considering zero control deflections, the rolling and yawing moments, and side forces induced by β_{GUST} were balanced by airplane inertia.

$$\ddot{\phi} = \left[I_{zz} (C_{l\beta}) + I_{xz} (C_{n\beta}) \right] (\beta_{GUST}) (qSb) / (I_{xx} I_{zz} - I_{xz}^2) \quad (6)$$

$$\dot{r} = \left[(C_{n\beta}) (\beta_{GUST}) (qSb) + I_{xz} \ddot{\phi} \right] / I_{zz} \quad (7)$$

$$n_y = \left[(C_{y\beta}) (\beta_{\text{GUST}}) qS \right] / W \quad (8)$$

The above equations were programmed for solution by a digital computer along with auxiliary equations defining airplane component loading.

3.4 AEROELASTIC CONSIDERATIONS

Although the computation of flight loads considered the effects of an elastic wing, rigid-body aerodynamics were otherwise employed. The derived loads are assumed to be adequately, if not conservatively, represented.

However, elastic coefficients - the ratio of an elastic stability derivative to its corresponding rigid value - included the additional affects of a flexible fuselage and a flexible empennage.

In addition, for both the wing and empennage flexibility effects of the control surfaces (aileron, elevator and rudder) and associated control linkage were not considered.

Pertinent techniques are described briefly in the following sub-sections.

3.4.1 Wing Aeroelasticity

Aeroelastic characteristics of the wing were determined by means of appropriately coupling structural influence coefficients with the analytical procedure discussed in Section 3.6.1 for calculating wing panel point loads. In its basic form, the structural coefficients relate linear deflections at points illustrated in Figure 3.8 with unit loads. Transforming this to an S-matrix (Tables 3.1 and 3.2) which relates angular deflection with a point load yielded

$$\{\epsilon\} = [S] \{f\} \quad (1)$$

E

However, as noted by the elastic subscript notation "E" an implicit solution of ϵ is involved, since elastic loading is the sum of the initially applied rigid load and the induced elastic load i. e.

$$\{f\} = \{f\} + \{f\} \quad (2)$$

E R IE

Since an aerodynamic influence coefficient matrix, A , can be derived which has the relationship

$$\{f\}_{IE} = [A] \{e\}, \quad (3)$$

it follows implicitly that:

$$\{e\} = \left[\begin{array}{cc} [I] & - [S] \\ & [A] \end{array} \right]^{-1} [S] \{f\}_R \quad (4)$$

The above equation thus enables the calculation of twist distribution for any type (α , δ_A , etc.) of rigid loading and through use of Equations (3) and (2), equilibrium elastic loading was established. Appropriate integration then yielded elastisized force and moment coefficients.

3.4.2 Empennage Aeroelasticity

As indicated previously, aeroelasticity of the empennage was evaluated solely for purposes of incorporation into stability analyses rather than structural loading determination.

In contrast to the wing analysis which used structural influence coefficients, elastic characteristics of the empennage were represented by an elastic beam(s) having flexibility in bending (EI) and torsion (GJ) shown in Figures 3.5 through 3.7.

Aerodynamic loading on the empennage was determined by an extension of "Lifting Line Theory" to account for interference effects and to provide solution of loadings due to angles of attack (α) and sideslip (β), angular rate or damping (p , q and r), and control surface deflections (δ_E and δ_R).

The fuselage was treated as a non-lifting elastic body which due to vertical and lateral bending only altered the effective free-stream orientation of the empennage and hence modified the magnitude and distribution of tail loading. Therefore, loading on the elastic tail was first determined (assuming a rigid fuselage) in terms of "Elastic Coefficients" which were subsequently modified to account for fuselage bending.

Algebraically, the net (combined body-tail deformations) elastic coefficients were calculated by

$$\frac{F_{E\text{TEF}}}{F_{R\text{TRF}}} = \frac{F_{E\text{TEF}}}{F_{E\text{TRF}}} \cdot \frac{F_{E\text{TRF}}}{F_{R\text{TRF}}} \sim \text{forces} \quad (5)$$

$$\frac{M_{E\text{TEF}}}{M_{R\text{TRF}}} = \frac{M_{E\text{TEF}}}{M_{E\text{TRF}}} \cdot \frac{M_{E\text{TRF}}}{M_{R\text{TRF}}} \sim \text{moments} \quad (6)$$

where the subscripts: R, E, T, and F denote, respectively, . . . rigid, elastic, tail and fuselage.

Typically, for an elevator-type (δ_E) of loading

$$\left(\frac{F_{E\text{TEF}}}{F_{E\text{TRF}}} \right)_{\delta_E} = \frac{1 - (C_{L\alpha})_{E\text{TRF}} \bar{q}_{ST} k_{m_y} [(\bar{X}_{cp})_{\delta_E} - (\bar{X}_{cp})_{\alpha}]}{1 + (C_{L\alpha})_{E\text{TRF}} \bar{q}_{ST} (k_{f_z} + k_{m_y} [(\bar{X}_{cp})_{\alpha}^{-209.22}])} \quad (7)$$

and

$$\left(\frac{M_{E\text{TEF}}}{M_{E\text{TRF}}} \right)_{\delta_E} = 1 - (F_z/M_y)_{E\text{TRF}} (M_y/F_z)_{E\text{TRF}} \left[1 - (F_{E\text{TEF}}/F_{E\text{TRF}})_{\delta_E} \right] \quad (8)$$

where

k_{f_z} = Angular deflection of the fuselage with respect to a unit vertical force applied at F. Sta. 455.22, deg/lb.

k_{m_y} = Angular deflection of the fuselage with respect to a unit moment at F. Sta. 455.22 due to a couple applied at the forward and rear spar of the Vertical Tail, deg/in-lb.

The counterparts to Equations (7) and (8) relevant to ETRF/RTRF were determined from loading distribution through a rigorous sequence of computations which were programmed to an IBM 704 Digital Computer. The crux of the problem was (similar to Sec. 3.4.1) the calculation of aerodynamic influence coefficients and solution of a system of simultaneous equations (33 X 33) after which was found elastic twist, stability derivatives, and finally elastic coefficients.

SYMMETRIC

(J)	1	2	3	4	5	6	7	8
1	6.2159395E-06	7.3339061E-07	-1.5524561E-07	-4.6258224E-07	-5.5395700E-07	-4.0606999E-07	-2.8576767E-07	-1.3148063E-07
2	-2.4771737E-05	-1.5095774E-06	-1.6221943E-06	-1.7463343E-06	-1.0696368E-06	-1.1900049E-06	-7.3996697E-07	-3.2042826E-07
3	-1.0520871E-05	-3.5849918E-06	-2.979590E-06	-2.9341853E-06	-2.7019710E-06	-1.9135261E-06	-1.1466571E-06	-4.9526070E-07
4	1.0845832E-06	4.5440838E-07	-1.379873E-07	-4.0562365E-07	-4.0415926E-07	-3.0006416E-07	-2.6298595E-07	-1.2073300E-07
5	-2.5953234E-06	-1.2605126E-06	-1.3285129E-06	-1.4305399E-06	-1.3716639E-06	-9.8920785E-07	-6.1712666E-07	-2.7063398E-07
6	-6.1256703E-06	-2.9116873E-06	-2.4759881E-06	-2.4199529E-06	-2.2790318E-06	-1.8894112E-06	-9.5949829E-07	-4.1558335E-07
7	1.4075725E-06	7.3645683E-07	7.2060382E-07	4.0365463E-07	2.3384599E-07	1.2461506E-07	2.1702175E-08	-8.6200253E-10
8	-1.923097E-06	-9.1583436E-07	-9.0184542E-07	-9.9556530E-07	-9.7142427E-07	-7.1702446E-07	-4.5763114E-07	-2.0365008E-07
9	-5.1994322E-06	-2.5392906E-06	-2.4916233E-06	-2.3718679E-06	-2.1578710E-06	-1.0459004E-06	-9.2999301E-07	-4.0353079E-07
10	2.6167592E-06	1.2891014E-06	1.2693556E-06	1.2613310E-06	1.0145493E-06	6.0616990E-07	3.3542428E-07	1.3162617E-07
11	-1.0935808E-06	-5.2299994E-07	-5.1328533E-07	-5.4250184E-07	-5.5046870E-07	-4.2948850E-07	-2.8946325E-07	-1.3292007E-07
12	-4.8203693E-06	-2.3410764E-06	-2.3007405E-06	-2.3541483E-06	-2.1220038E-06	-1.0294117E-06	-9.1654825E-07	-3.98641087E-07
13	4.2981405E-06	2.0964898E-06	2.0479153E-06	2.0769391E-06	1.9472254E-06	1.3525944E-06	7.4462866E-07	3.0652918E-07
14	3.5585910E-06	1.7568250E-06	1.6964509E-06	1.7206018E-06	1.6136445E-06	1.1202609E-06	6.0927681E-07	2.4962617E-07
15	-3.2410351E-07	-1.5147767E-07	-1.5124443E-07	-1.6607769E-07	-1.7451369E-07	-1.0290320E-07	-1.2768971E-07	-6.340920E-08
16	-4.3433907E-06	-4.1075741E-06	-2.0646262E-06	-2.1139970E-06	-2.0080324E-06	-1.4729142E-06	-8.8442813E-07	-3.8622075E-07
17	2.8188145E-06	1.3728307E-06	1.3375758E-06	1.3617183E-06	1.3154110E-06	1.0083409E-06	6.3626919E-07	2.7188181E-07
18	-3.2137659E-06	-1.5985684E-06	-1.529302E-06	-1.5621819E-06	-1.5092973E-06	-1.2515879E-06	-7.7727841E-07	-3.4651290E-07
19	2.0370455E-06	9.9060699E-07	9.6465749E-07	9.8318927E-07	9.5632744E-07	6.1145819E-07	5.7757240E-07	2.6156406E-07
20	1.6015105E-06	8.7630045E-07	8.5316820E-07	8.6580851E-07	8.4957703E-07	7.3753146E-07	5.2757712E-07	2.4162594E-07
21	-6.9988444E-08	-3.2475032E-08	-3.3097964E-08	-3.6515694E-08	-3.4637820E-08	-2.7811520E-08	-2.6452047E-08	-1.4782704E-08
22	4.5755174E-08	4.2218571E-08	2.1668172E-08	2.2162922E-08	2.1635134E-08	1.00865903E-08	1.3674796E-08	6.3538654E-09
23	-1.9230728E-06	-9.3232733E-07	-9.1065933E-07	-9.3411419E-07	-9.1086082E-07	-7.9188079E-07	-5.8028131E-07	-2.7211344E-07
24	7.5250707E-07	3.6587984E-07	3.5604160E-07	3.6327686E-07	3.5699772E-07	3.1960800E-07	2.4416560E-07	1.5123341E-07
25	-6.2469794E-07	-3.9975428E-07	-3.5024576E-07	-4.0043440E-07	-3.9239914E-07	-3.4447473E-07	-2.6957254E-07	-1.6872429E-07

Table 3.1 Wing Flexibility Matrix, (S) - rad/lb., Symmetrical Loading

ANTISYMMETRIC

(J)	1	2	3	4	5	6	7	PAGE
1	5.0028666E-06	4.9252321E-07	-4.4412010E-07	-7.5056846E-07	-8.4197636E-07	-6.0162029E-07	-4.7969995E-07	
2	-2.8537743E-06	-1.6850932E-06	-1.7932248E-06	-1.9162579E-06	-1.0392067E-06	-1.3395776E-06	-8.4608668E-07	
3	-1.3650050E-05	-5.6492139E-06	-3.0407760E-06	-2.9942750E-06	-2.7621315E-06	-1.7668067E-06	-1.1869534E-06	
4	5.4701820E-07	-1.9252000E-07	-3.9718005E-07	-6.0294521E-07	-7.3724627E-07	-5.7981988E-07	-4.2982360E-07	
5	-2.8434314E-06	-1.4467198E-06	-1.0693550E-06	-1.3224795E-06	-1.2310014E-06	-1.1149447E-06	-7.2211405E-07	
6	-6.4731270E-05	-2.9037761E-06	-2.0432411E-06	-4.4004739E-06	-2.2972578E-06	-1.0497665E-06	-1.0048061E-06	
7	8.0167377E-07	4.4110139E-07	4.5393596E-07	1.1259491E-07	5.2143254E-06	-1.2700618E-07	-1.6672909E-07	
8	-2.2598901E-05	-1.0602741E-06	-1.0610401E-06	-1.1563466E-06	-1.1298901E-06	-8.2657976E-07	-2.6219777E-07	
9	-2.2727432E-06	-4.5757216E-06	-2.3340644E-06	-2.4051778E-06	-2.1914980E-06	-1.5758184E-06	-9.5251712E-07	
10	1.9257775E-06	9.5255515E-07	9.4234309E-07	9.2674043E-07	6.0605142E-07	5.7904070E-07	1.2042723E-07	
11	-1.4345537E-06	-5.3347944E-07	-5.7439721E-07	-7.3374931E-07	-7.1116941E-07	-5.7398200E-07	-3.9346466E-07	
12	-4.8911493E-06	-1.9373209E-06	-2.2921414E-06	-2.3479219E-06	-2.1167624E-06	-1.3251365E-06	-9.1346672E-07	
13	3.4652290E-06	-1.6911721E-06	-1.6536994E-06	-1.6753767E-06	-1.5533557E-06	-1.0063224E-06	-4.6541110E-07	
14	2.5025971E-06	1.3586728E-06	1.3356435E-06	1.3562517E-06	1.2562034E-06	8.0599617E-07	3.7401105E-07	
15	-6.8593516E-07	-3.1790673E-07	-3.1293275E-07	-3.2976370E-07	-3.5547635E-07	-2.2670425E-07	-2.3300216E-07	
16	-4.2630620E-06	-2.0052243E-06	-2.0235694E-06	-2.0727722E-06	-1.8609731E-06	-1.3903434E-06	-6.5809461E-07	
17	2.1402160E-06	1.0459753E-06	1.0192435E-06	1.0373794E-06	9.8752609E-07	8.6375641E-07	4.2695097E-07	
18	-3.0841790E-06	-1.49660954E-06	-1.4649631E-06	-1.4904445E-06	-1.4473931E-06	-1.1374127E-06	-7.3061025E-07	
19	1.4780310E-06	7.1671513E-07	7.0078663E-07	7.1344476E-07	5.9388275E-07	5.792348E-07	4.0559222E-07	
20	1.2624001E-06	6.2003218E-07	6.0791733E-07	6.1940619E-07	6.0407030E-07	5.2173035E-07	3.6584599E-07	
21	-2.6279109E-07	-1.2045099E-07	-1.2431625E-07	-1.2910352E-07	-1.2552907E-07	-1.0767470E-07	-8.6411068E-06	
22	3.7771830E-08	1.6339967E-06	1.7865874E-06	1.6300905E-06	1.7853662E-06	1.5544199E-06	1.1169128E-06	
23	-1.7925501E-06	-8.5922202E-07	-8.4602627E-07	-8.7027469E-07	-8.5571442E-07	-7.3741054E-07	-5.3927566E-07	
24	4.6663250E-07	2.2094133E-07	2.203710E-07	2.2542641E-07	2.155730E-07	2.0082375E-07	1.5526095E-07	
25	-7.3719983E-07	-3.5740145E-07	-3.4460471E-07	-3.5777043E-07	-3.9075056E-07	-3.1299465E-07	-2.4229790E-07	

Table 3.2 Wing Flexibility Matrix, (S) - rad/lb., Antisymmetric Loading

$$H.S. \sim GJ \cdot 10^{-7}, \text{ lbs-in}^2$$

$$V.S. \sim GJ \cdot 10^{-8}, \text{ lbs-in}^2$$

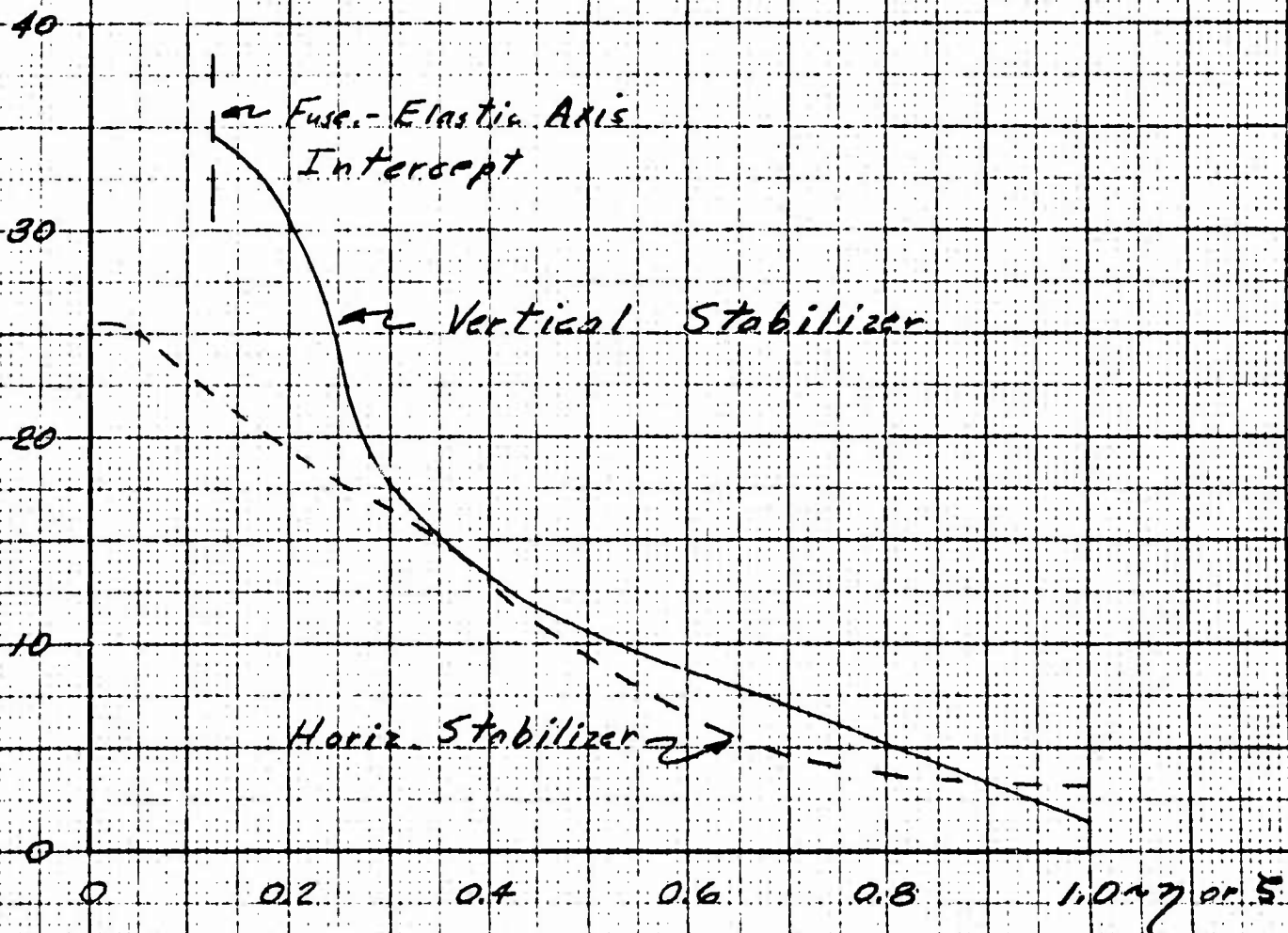

Figure 3.5 Empennage Torsional Stiffness

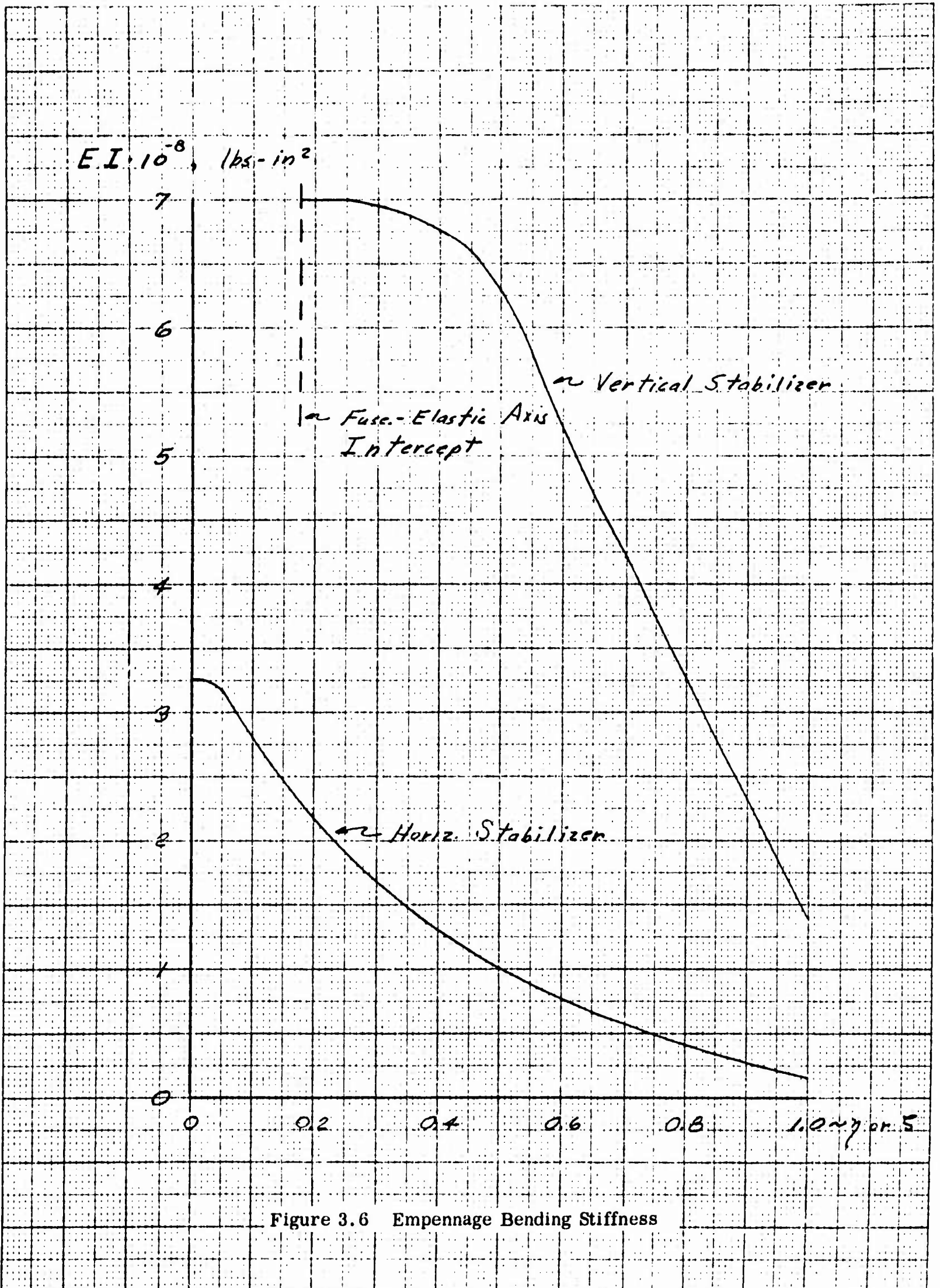

Figure 3.6 Empennage Bending Stiffness

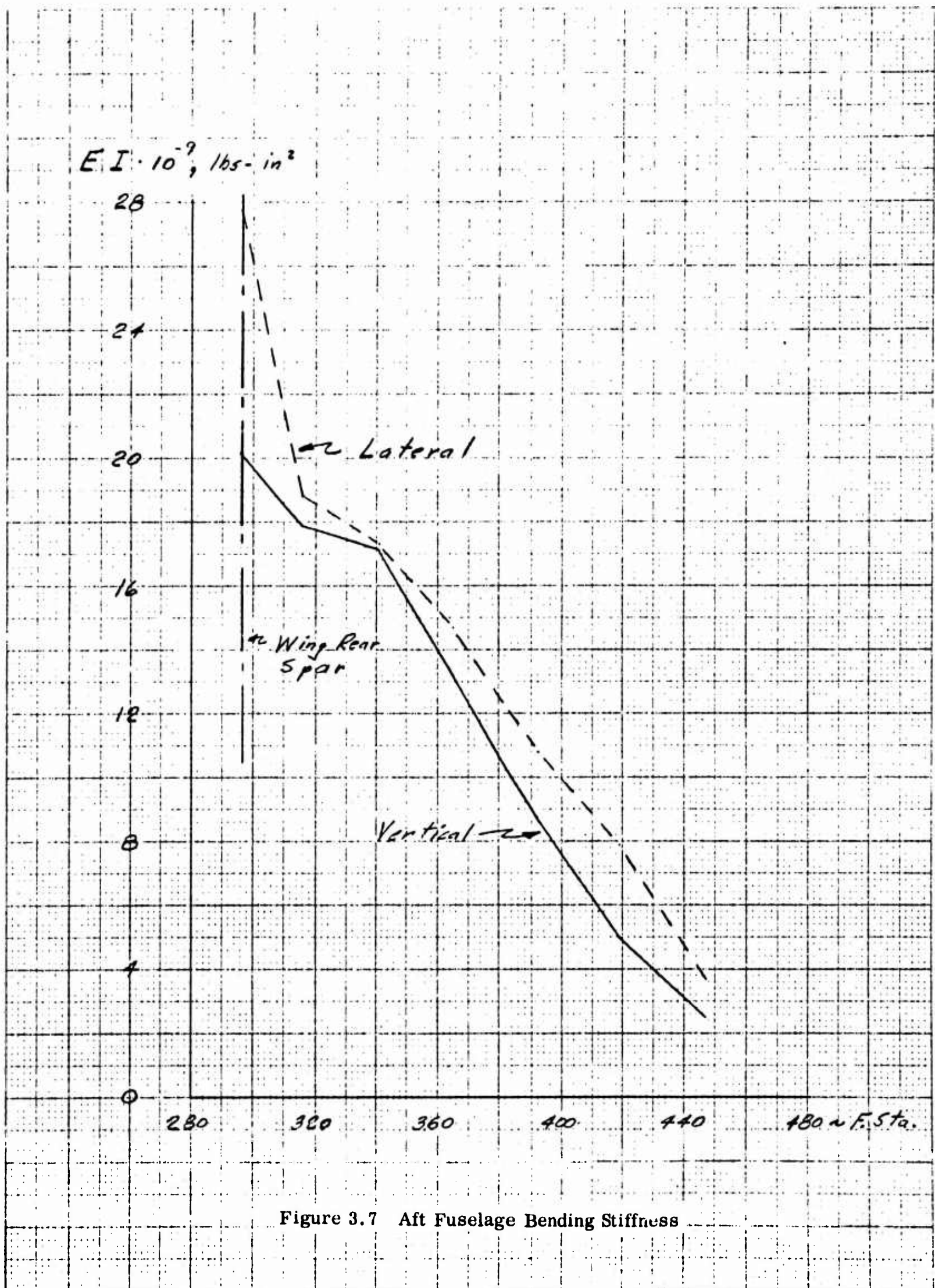

Figure 3.7 Aft Fuselage Bending Stiffness

3.5 LANDING

The method of Reference 5 was utilized to determine ground reactions for the following specific configurations:

Conventional Landings (Gear Forward)

1. 9200 lbs. , 10 ft./sec. sink speed
2. 12,500 lbs. , 6 ft./sec. sink speed

Vertical Landings (Gear Aft)

1. 9200 lbs. , 10 ft./sec. sink speed

Emergency Landings (Gear Aft)

1. 9200 lbs. , 6 ft./sec. sink speed.
(Corresponds to a "conventional" landing with gear aft but loads treated as ultimate.)

The complete work in this category may be found in Reference 6.

3.6 DISTRIBUTION OF LOADING

3.6.1 Wing Loading Distribution

In general, the distribution of wing (exposed) loading -- inertial, aerodynamic, and induced aeroelastic -- was represented by concentrated forces (except for a fan center-line "couple") at a discreet number and location of "panel points" depicted by Figure 3.8. Although the stress analyses employed panel points 100-126, additional points were incorporated in the loads analysis. The effect of these on the foregoing points was, however, appropriately included.

For this mathematical model, analytical expressions were derived and subsequently programmed for solution on a digital computer (IBM 704). Although the detailed equations are not presented herein, the essential considerations reflected in the analysis are presented in the following sub-sections.

3.6.1.1 Inertial Loading

Inertial loadings accounted for were those produced by linear (n_z) and angular ($\ddot{\theta}$ and $\ddot{\psi}$) accelerations. To determine localized effects, it was necessary to partition the wing into a series of rectangular areas which encompassed, concentrically, each panel point. Within each area the localized wing weight, cg and moments of inertia were then determined and, as a final correction, redistributed in terms of unit loads to the exact panel point locations in such a manner that inertia properties of the complete wing were preserved.

3.6.1.2 Aerodynamic Loading

The transformation of aerodynamic loading into a finite number and location of point loads was, in essence, a process of synthesizing values which best duplicated the "exact" distributions of wing shear, bending and torsion. In determining shear, bending, and torque, however, it was necessary to analyze and/or separate the loading — represented by wind-tunnel surface pressures — in terms of distinct contributions and the structural component to which it was proportionately applied. By contribution of loading is meant either of a "basic" type at zero angle of attack or linearized "additional" type due to angle of attack, aileron deflection, flap deflection, etc.

Distributions used in the panel point loads analysis are presented in Figures 3.9 through 3.27. Except for the theoretical roll damping distribution, all other data were derived from wind-tunnel pressure data typified by that shown in Figures 3.28 through 3.39.

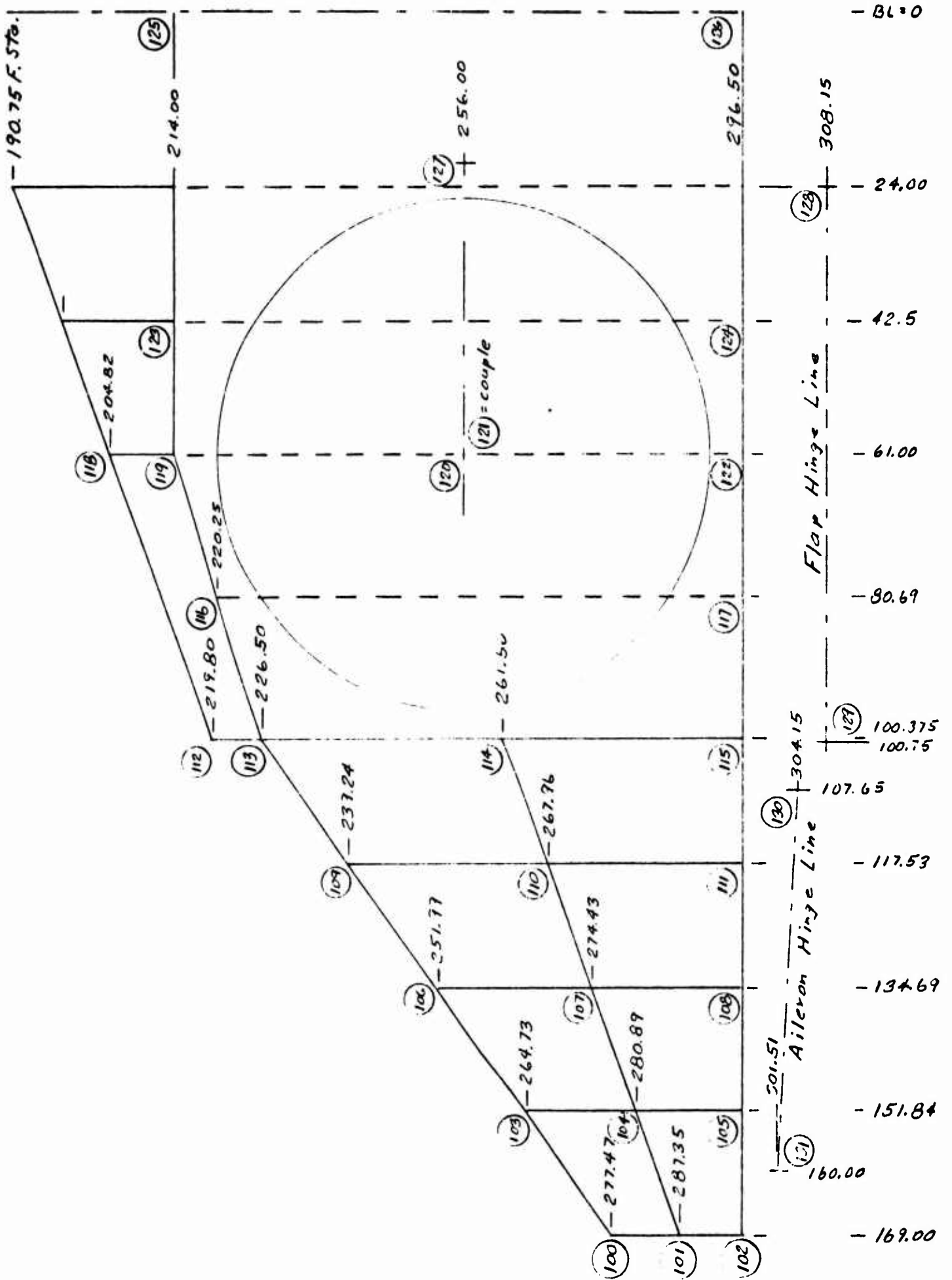

Figure 3.8 Wing Panel Point Geometry

$$\left(\frac{C_n C}{b\alpha}\right)^{A, FP} \cdot 10^4, \text{ per deg.}$$

$$\left(\frac{C_n C}{b\alpha}\right)^{CW, FN} \cdot 10^3, \text{ per deg.}$$

Symbol

- Complete Wing, CW
- △ Fan, FN
- ◇ Flap (FP) & Aileron (A)

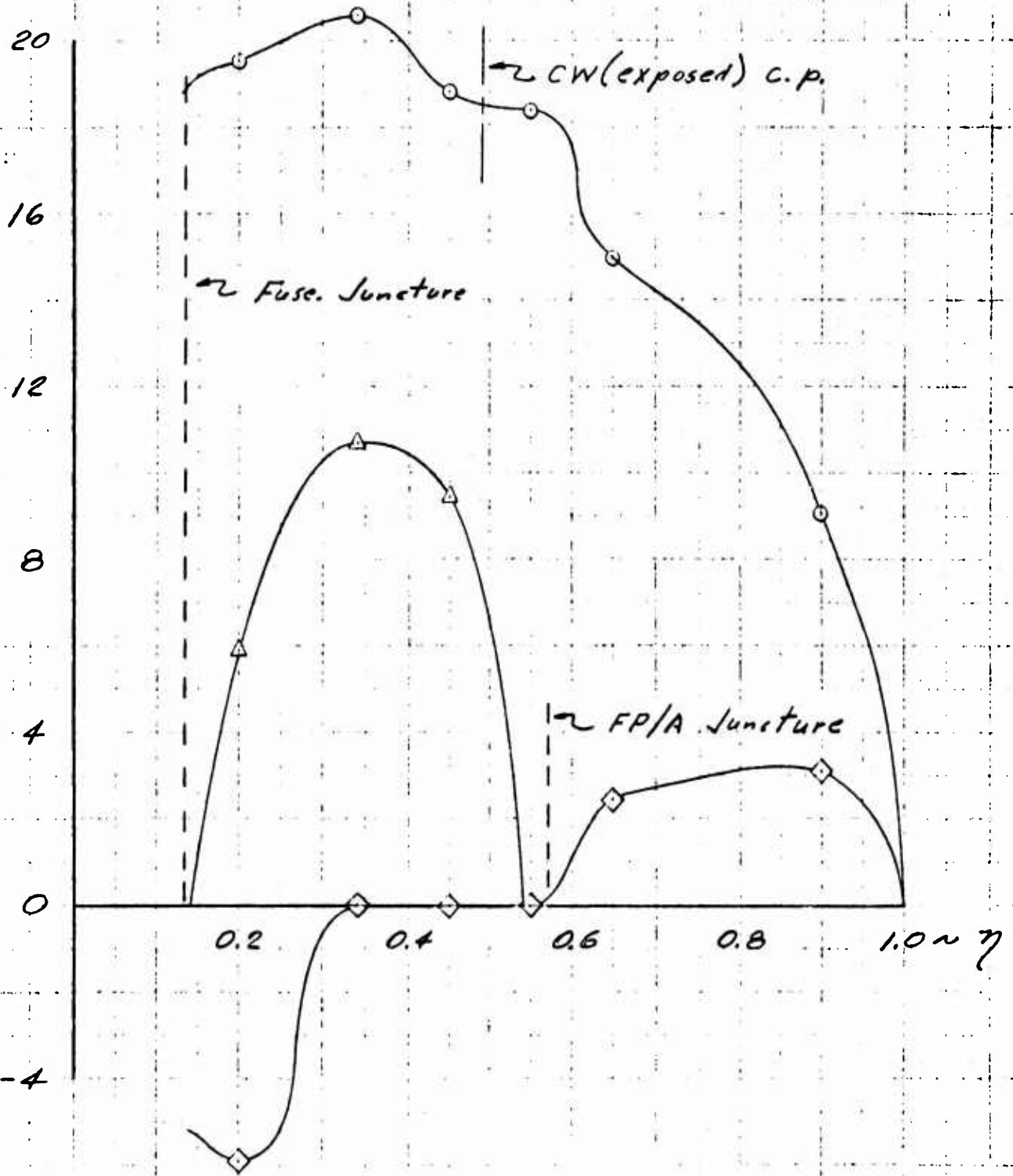

Figure 3.9 Loading Distribution Due to Angle of Attack, $M=0.285$, Flaps Retracted

$$\left(\frac{C_{D,C}}{b}\right)_{\alpha=0}$$

Symbol

- Complete Wing, CW
- △ Fan, FN
- ◇ Flap (FP) & Aileron (A)

.02

.01

.01

.02

.03

Fuse. Juncture

FP/A Juncture

0.2

0.4

0.6

0.8

1.0 ~ η

Figure 3.10 Loading Distribution at Zero Angle of Attack, M = 0.285, Flaps Retracted

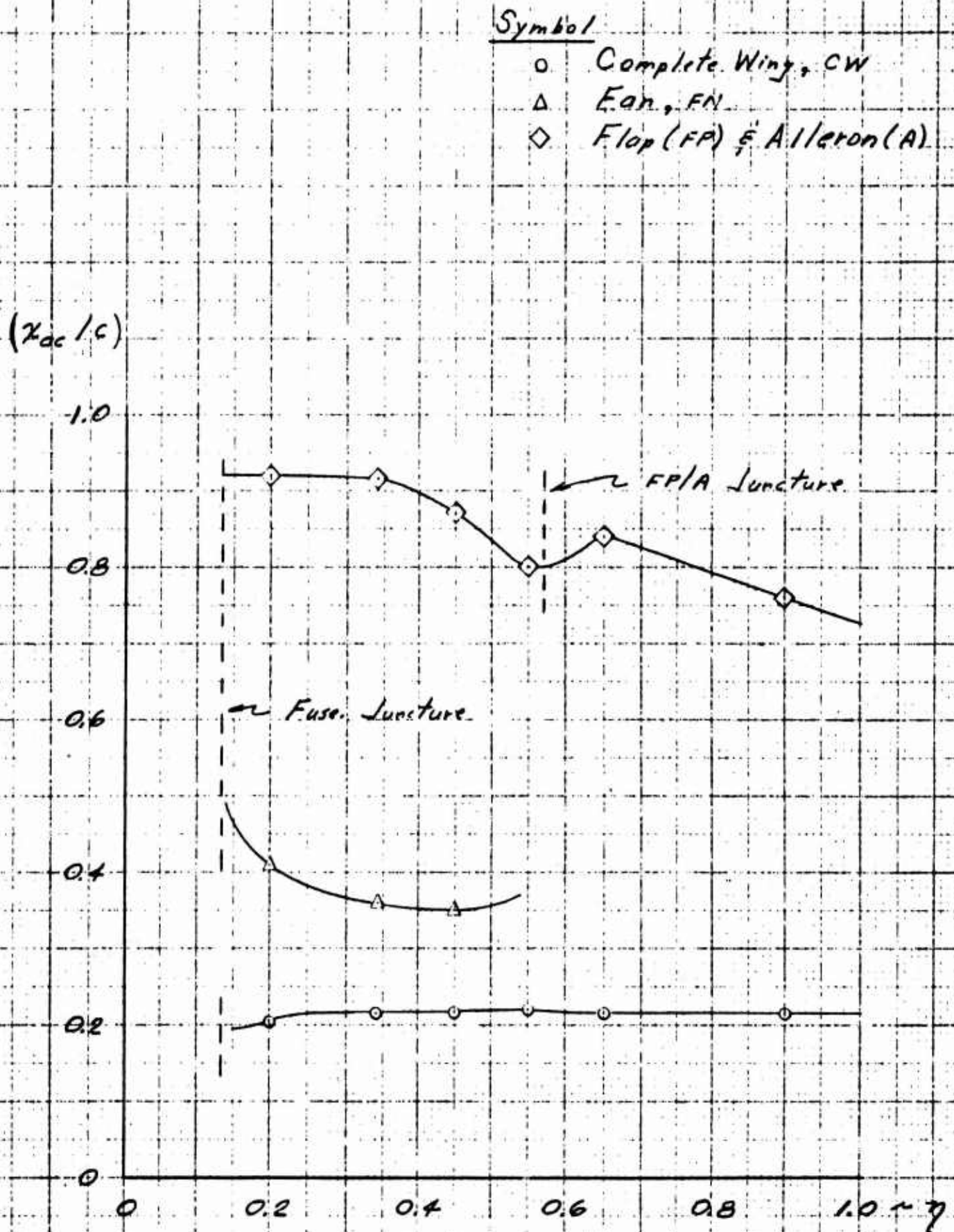

Figure 3.11 Distribution of Local Aerodynamic Center, $M=0.285$, Flaps Retracted

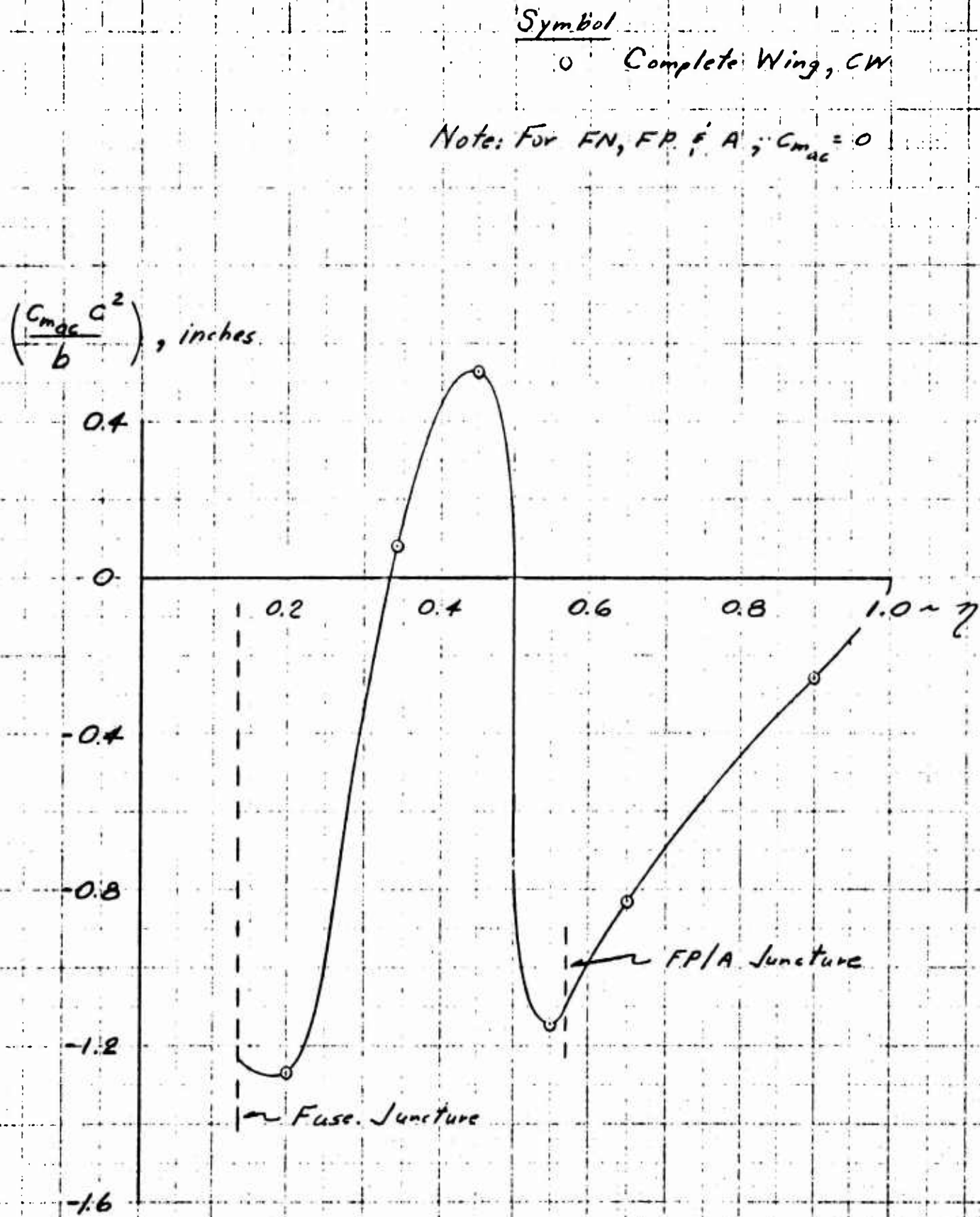

Figure 3.12 Distribution of Local Pitching Moment, $M=0.285$, Flaps Retracted

$\left(\frac{C_n C}{b \alpha}\right) \cdot 10^3, \text{ per deg}$

Symbol

- Complete Wing, CW
- △ Fan, FN

Note: For $FP \dot{E} A, \dots C_{n\alpha} = 0$

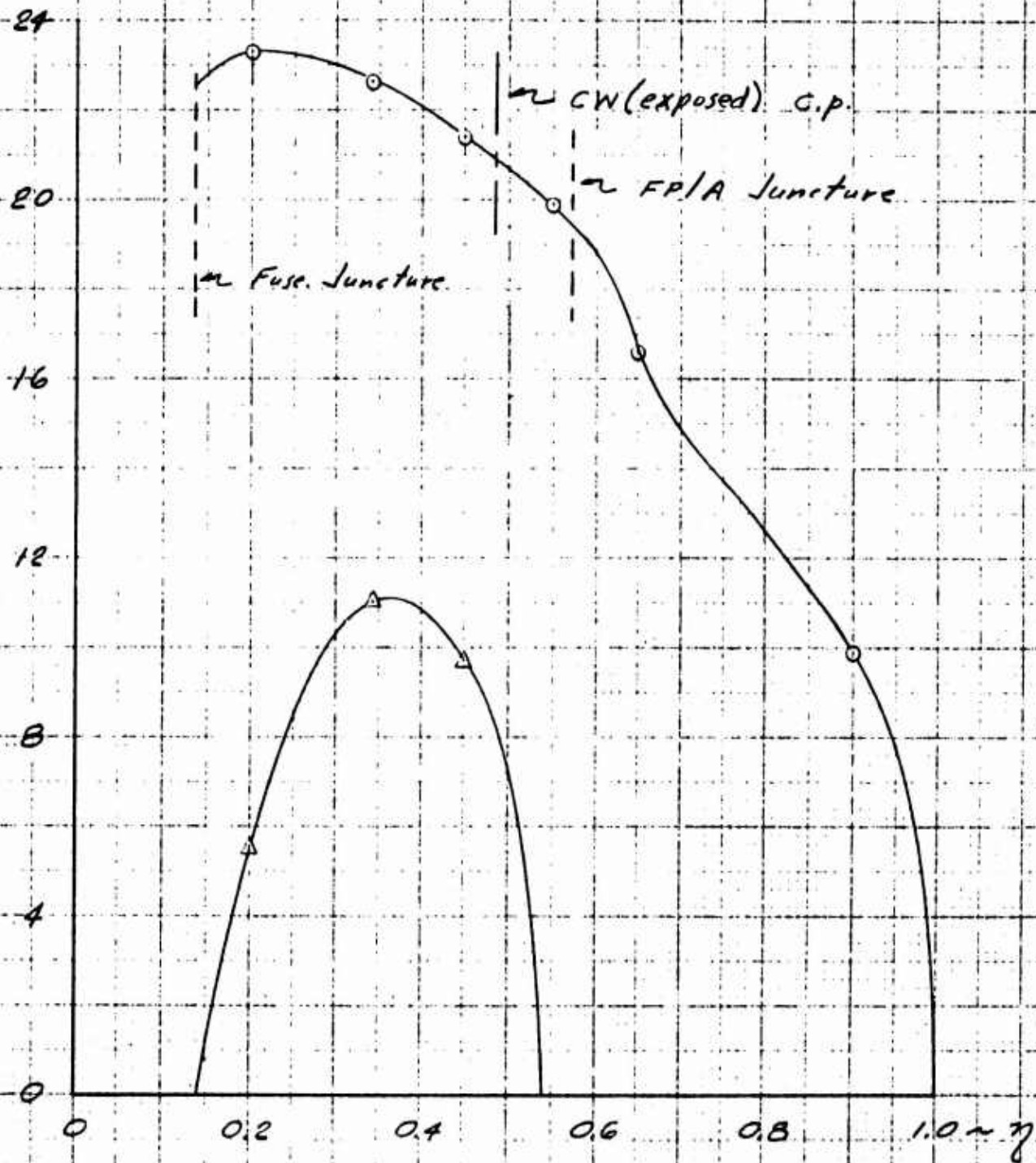

Figure 3.13 Loading Distribution Due to Angle of Attack, $M=0.285$, Flaps Extended 45°

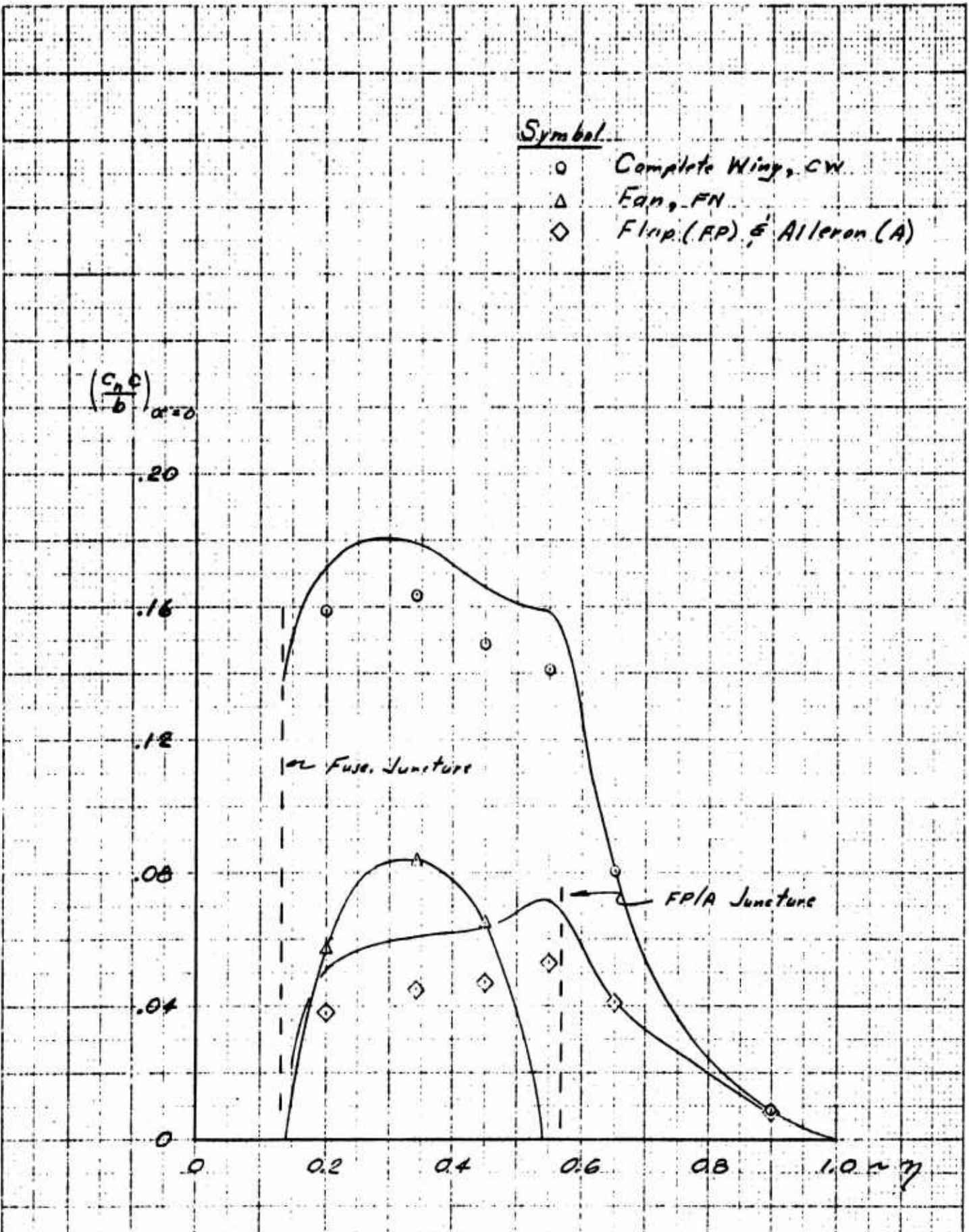

Figure 3.14 Loading Distribution at Zero Angle of Attack, $M=0.285$, Flaps Extended 45°

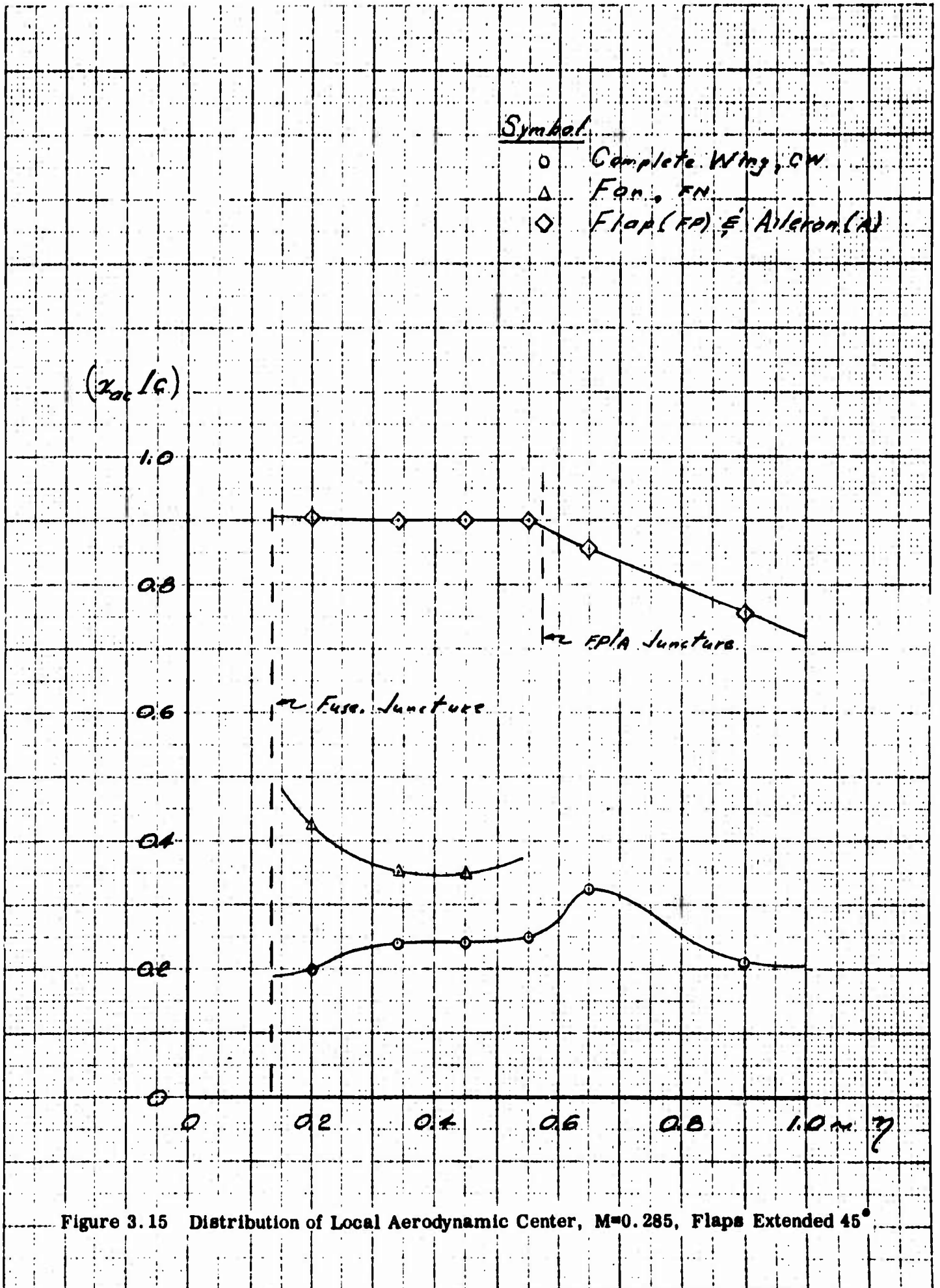

Figure 3.15 Distribution of Local Aerodynamic Center, $M=0.285$, Flaps Extended 45°

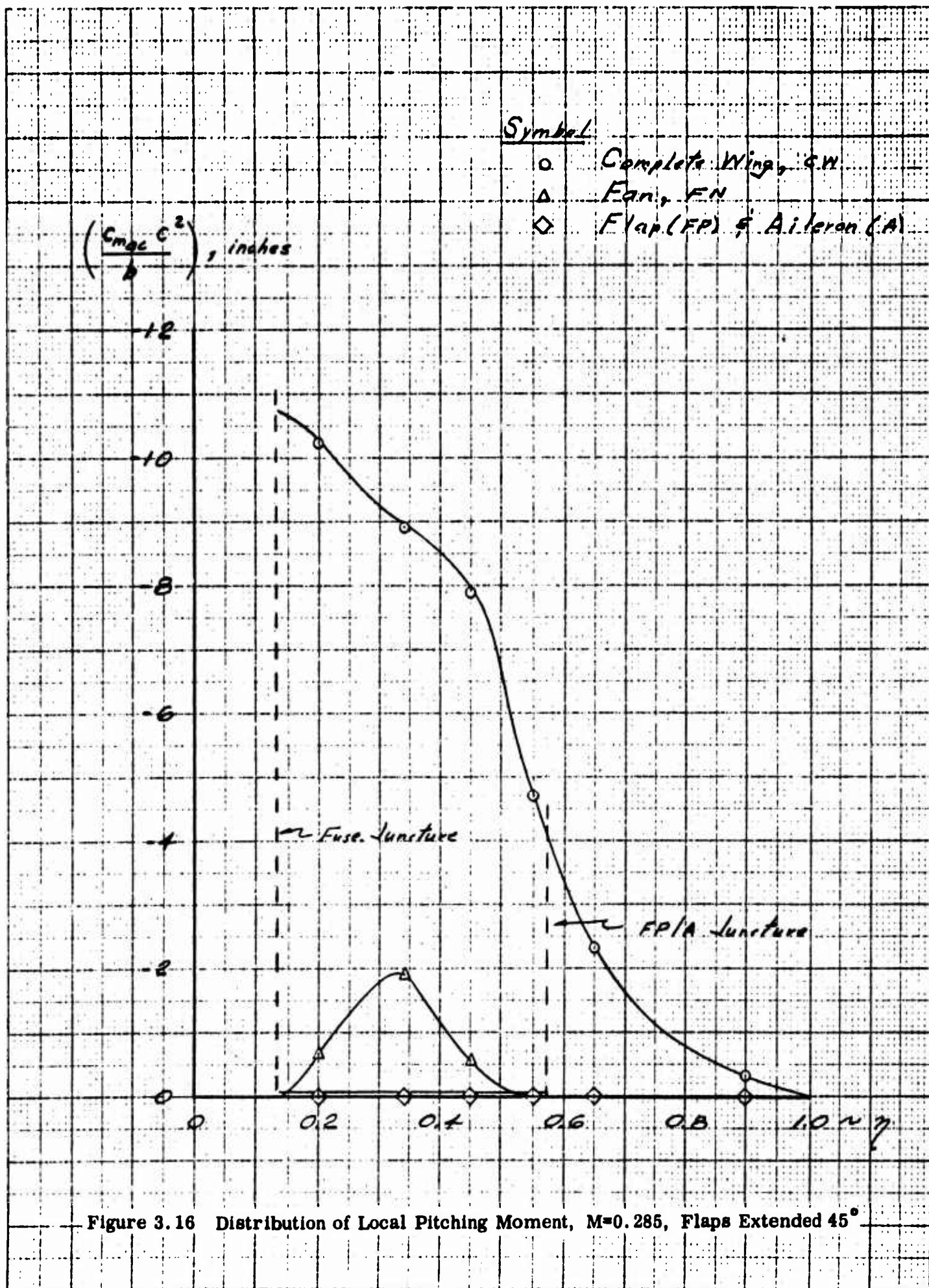

Figure 3.16 Distribution of Local Pitching Moment, $M=0.285$, Flaps Extended 45°

$\left(\frac{C_{n,c}}{b\alpha}\right) \cdot 10^4$, per deg. A, FR.
 $\left(\frac{C_{n,c}}{b\alpha}\right) \cdot 10^3$, per deg. CW, FN.

Symbol

- Complete Wing, CW
- △ Fap, FN
- ◇ Flap (FR) & Aileron (A)

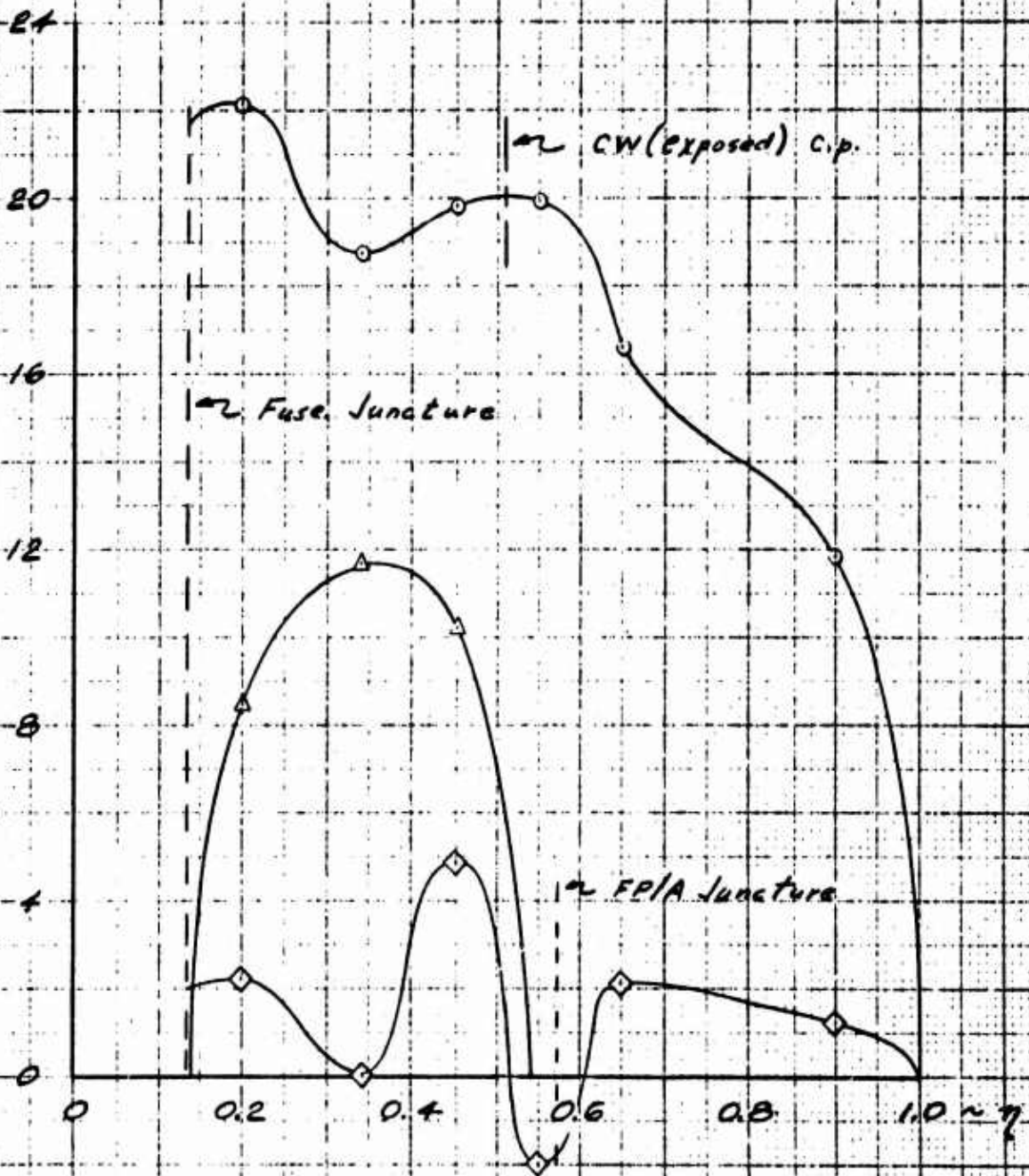

Figure 3.17 Loading Distribution Due to Angle of Attack, $M=0.8$

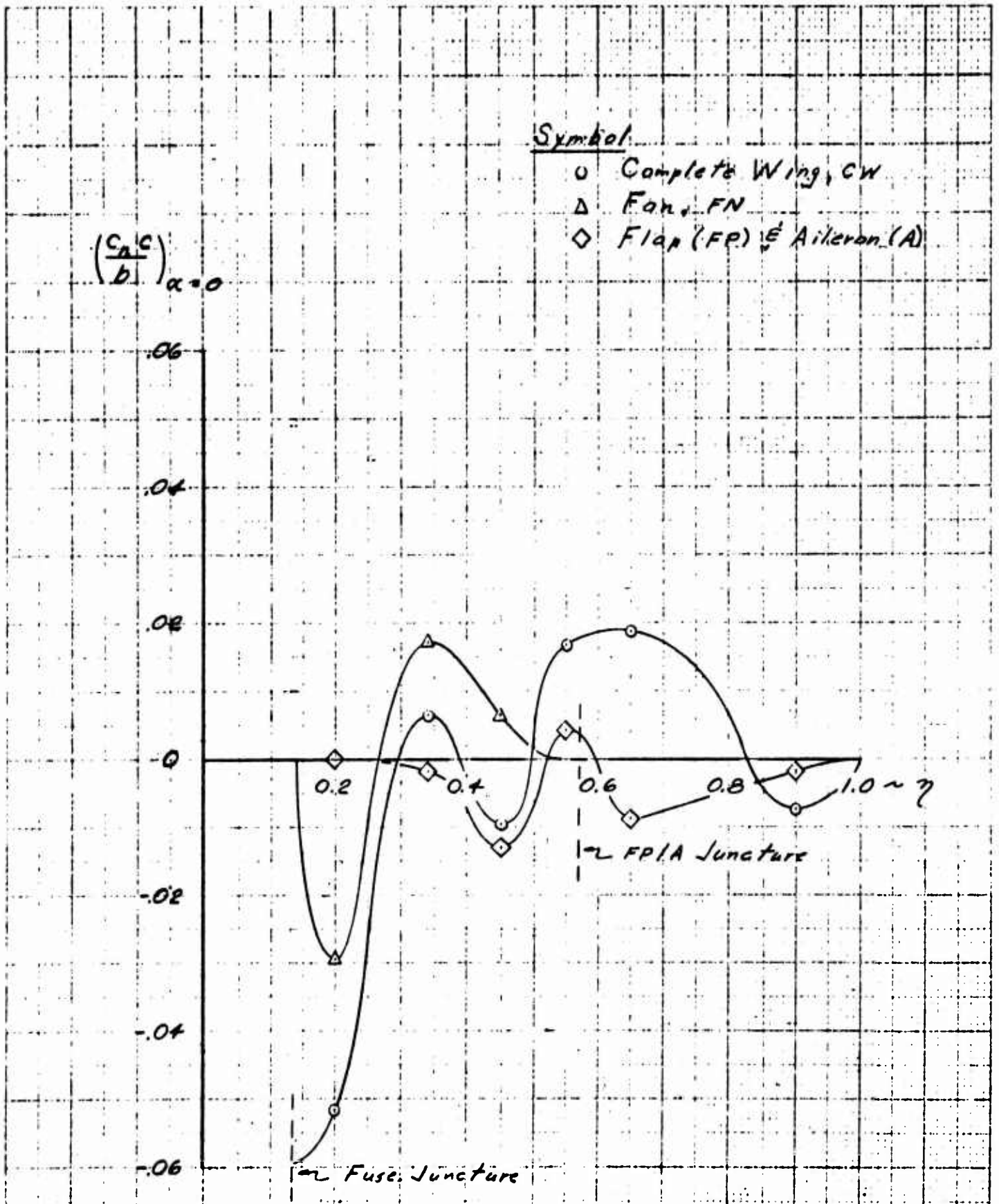

Figure 3.18 Loading Distribution at Zero Angle of Attack, $M=0.8$

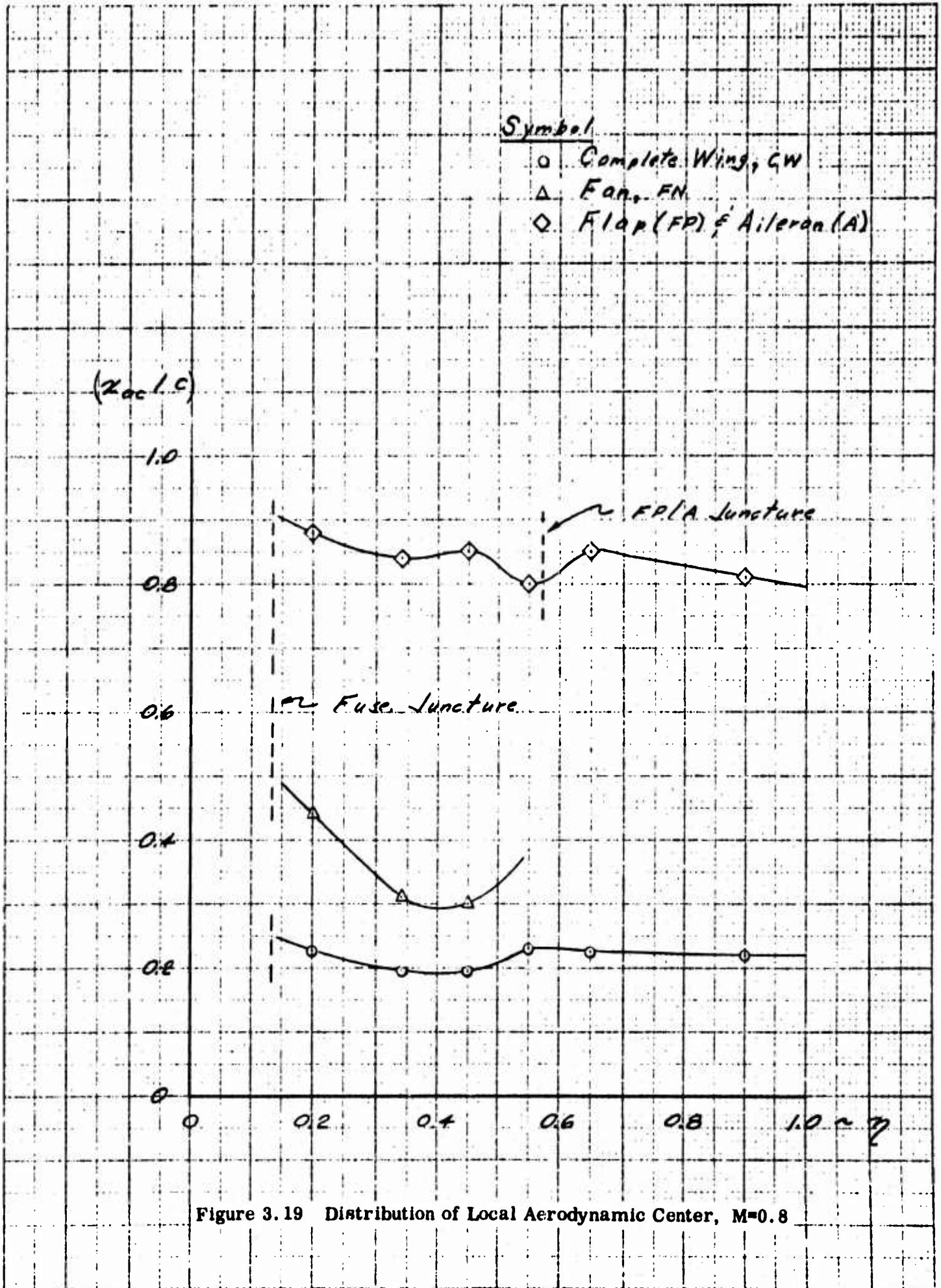
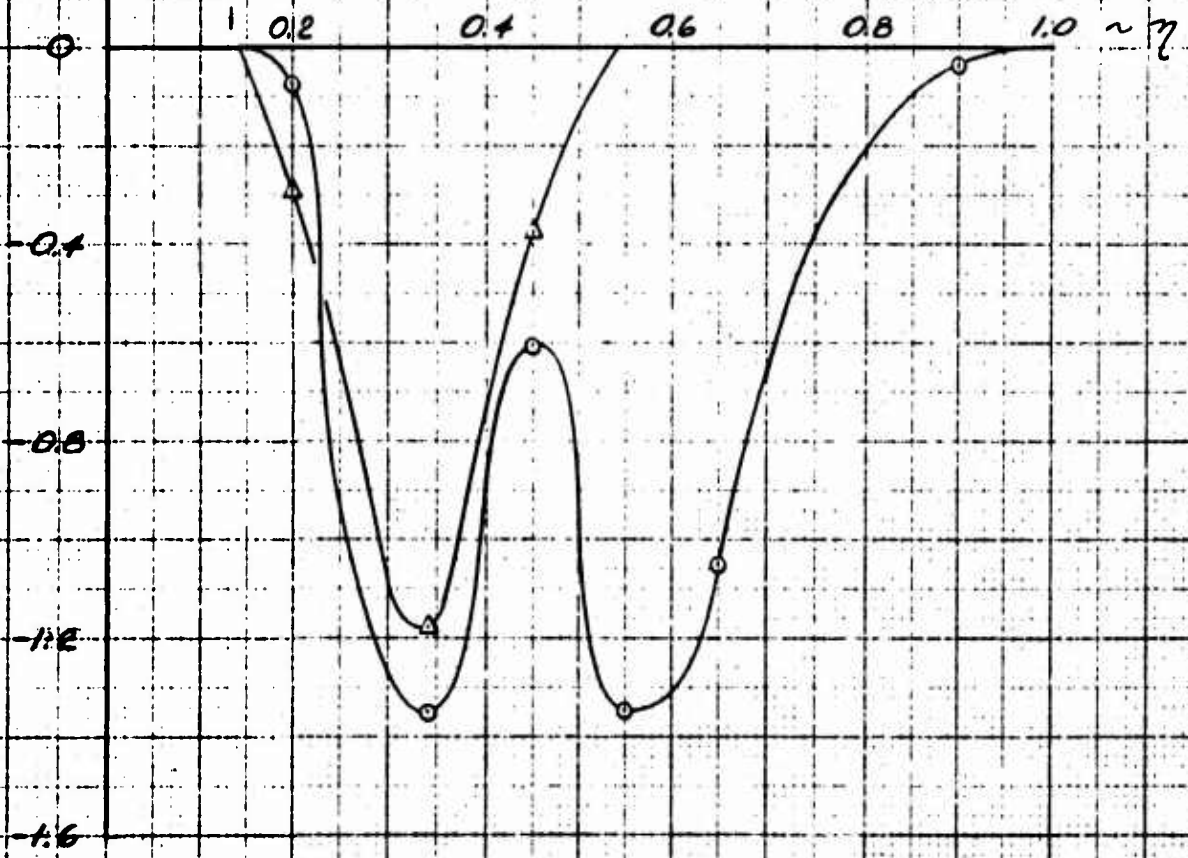

Figure 3.19 Distribution of Local Aerodynamic Center, M=0.8

$\left(\frac{C_{mac} c^2}{b}\right)$, inches

0.4

Fuse. Juncture



Symbol

- o Complete Wing, CW
- Δ Fan, FN

Note: For EPFA, $C_{mac} = 0$

Figure 3.20 Distribution of Local Pitching Moment, $M=0.8$

$\left(\frac{C_n C}{b \alpha}\right) \cdot 10^3, \text{ per deg.}$

Symbol

- Complete Wing, CW
- △ Fan, FN
- ◇ Flap (FP) & Aileron (A)

28

24

20

16

12

8

4

0

0

0.2

0.4

0.6

0.8

1.0 η

~ CW(exposed) c.p.

~ FP/A Junction

~ Fuse Junction

Figure 3.21 Loading Distribution Due to Angle of Attack, $M=0.9$

$$\left(\frac{C_{n_c}}{b}\right)_{\alpha=0}$$

.02

0

-.02

-.04

-.06

-.08

-.10

-.12

-.14

0.2

0.4

0.6

0.8

1.0 ~ 7

Symbol

○ Complete Wing, CW

△ Fon, FN

◇ Flap (FP) & Aileron (A)

Fuse. Junction

FRLA Junction

Figure 3.22 Loading Distribution at Zero Angle of Attack, M=0.9

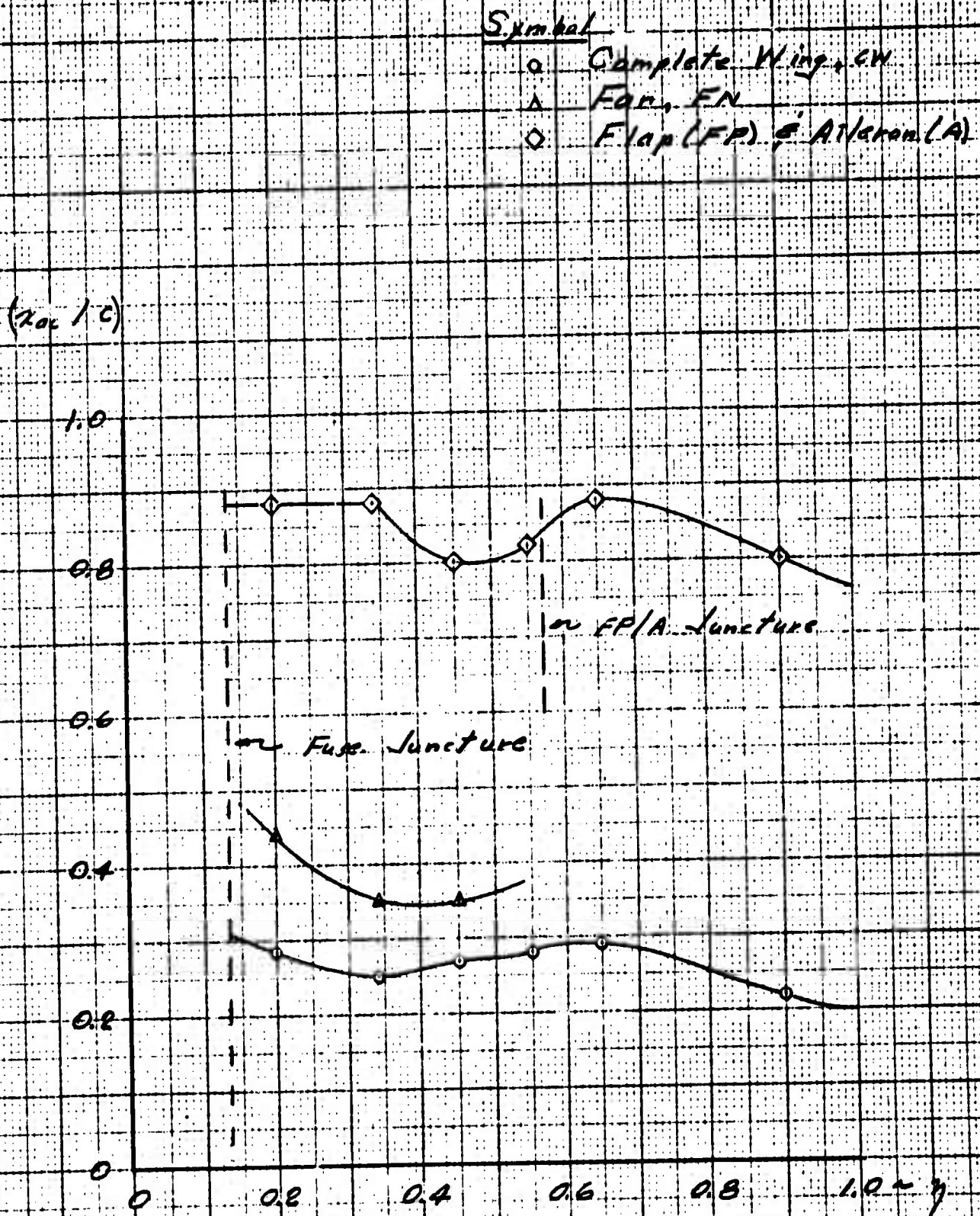

Figure 3.23 Distribution of Local Aerodynamic Center, $M=0.9$

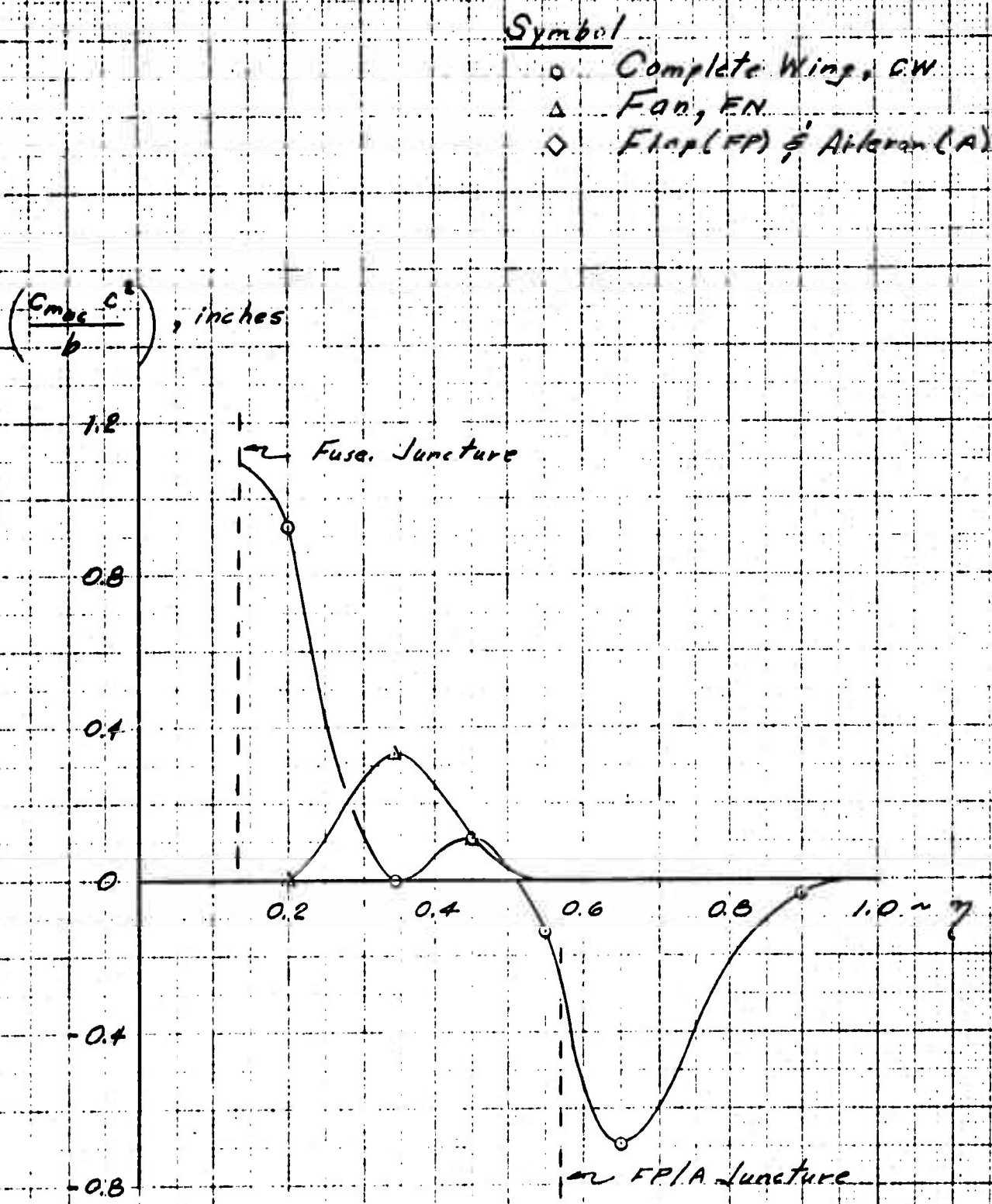

Figure 3.24 Distribution of Local Pitching Moment, $M=0.9$

$$10^3 \cdot \left(\frac{C_m C_l}{b \delta_{AL}} \right), \text{ per deg.}$$

Symbol

- Complete Wing, CW
- △ F.O.N., FN
- ◇ Flap (FR) & Aileron

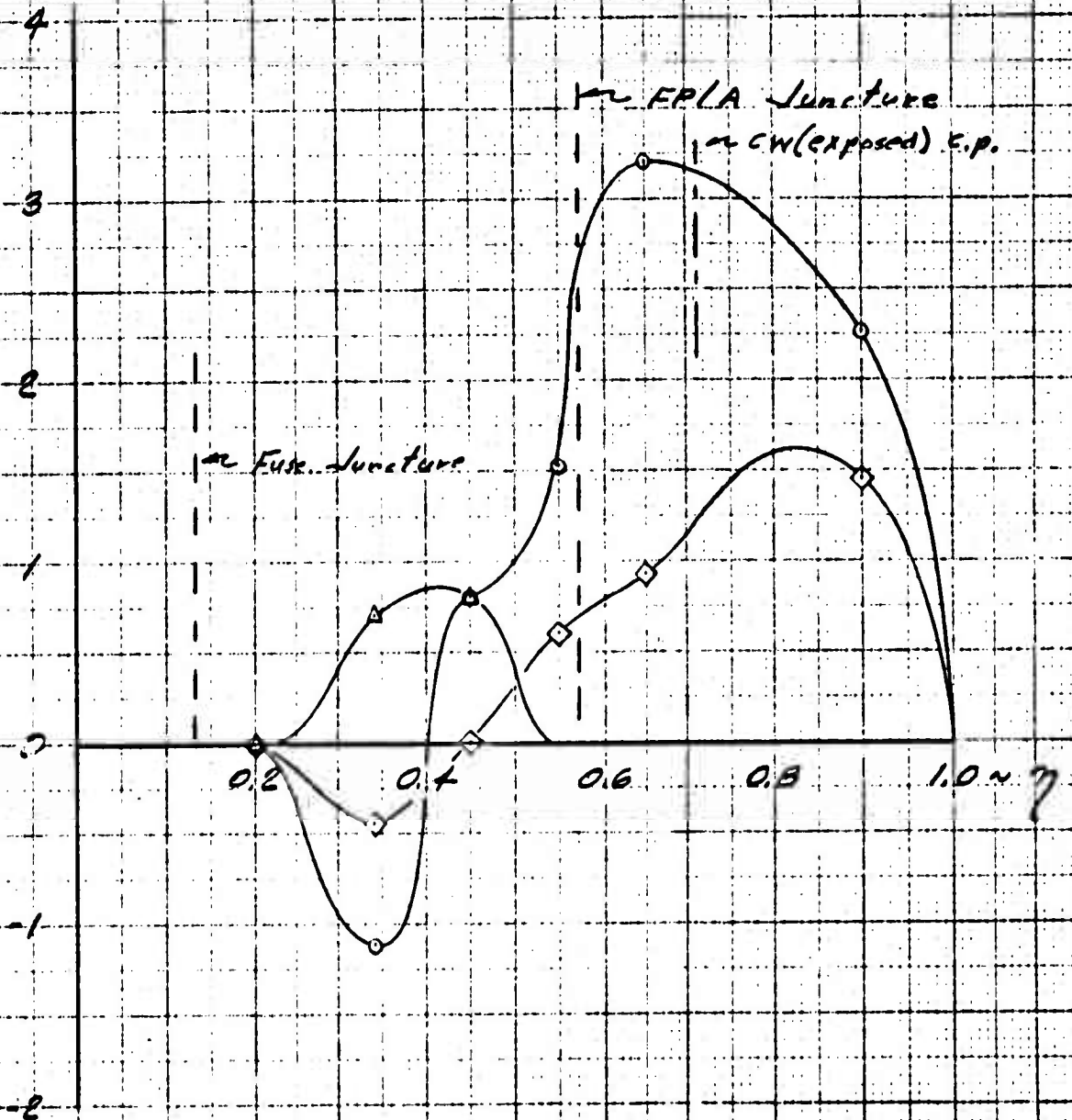

Figure 3.25 Loading Distribution Due to Aileron Deflection, $M=0.285$

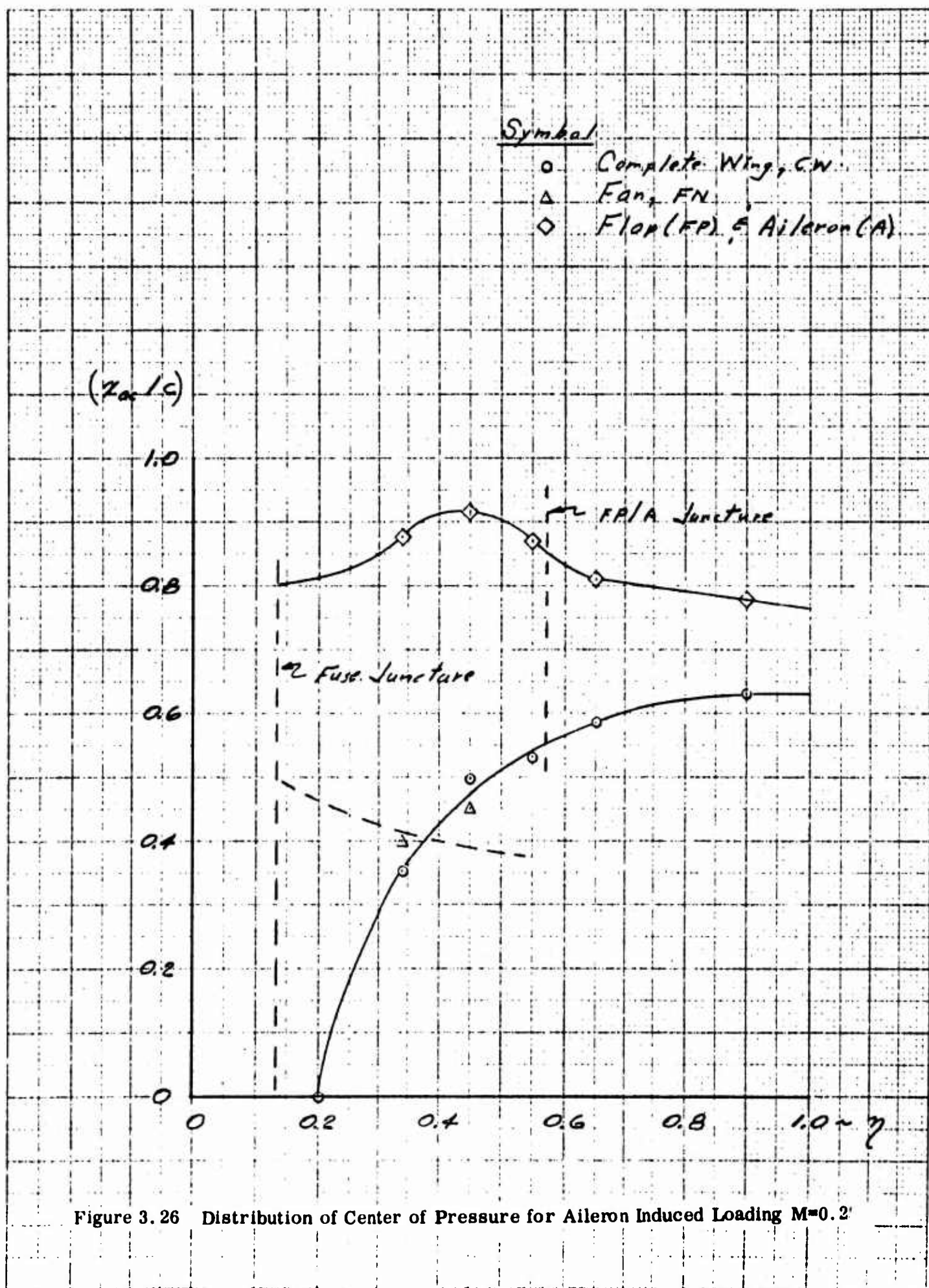

Figure 3.26 Distribution of Center of Pressure for Aileron Induced Loading $M=0.2$

Symbol	Mach No.
—	0.8
- - -	0.285

$$\left(\frac{2V \cdot C_n \cdot C}{\phi \cdot b^2}\right) \cdot 10^3, \text{ per deg.}$$

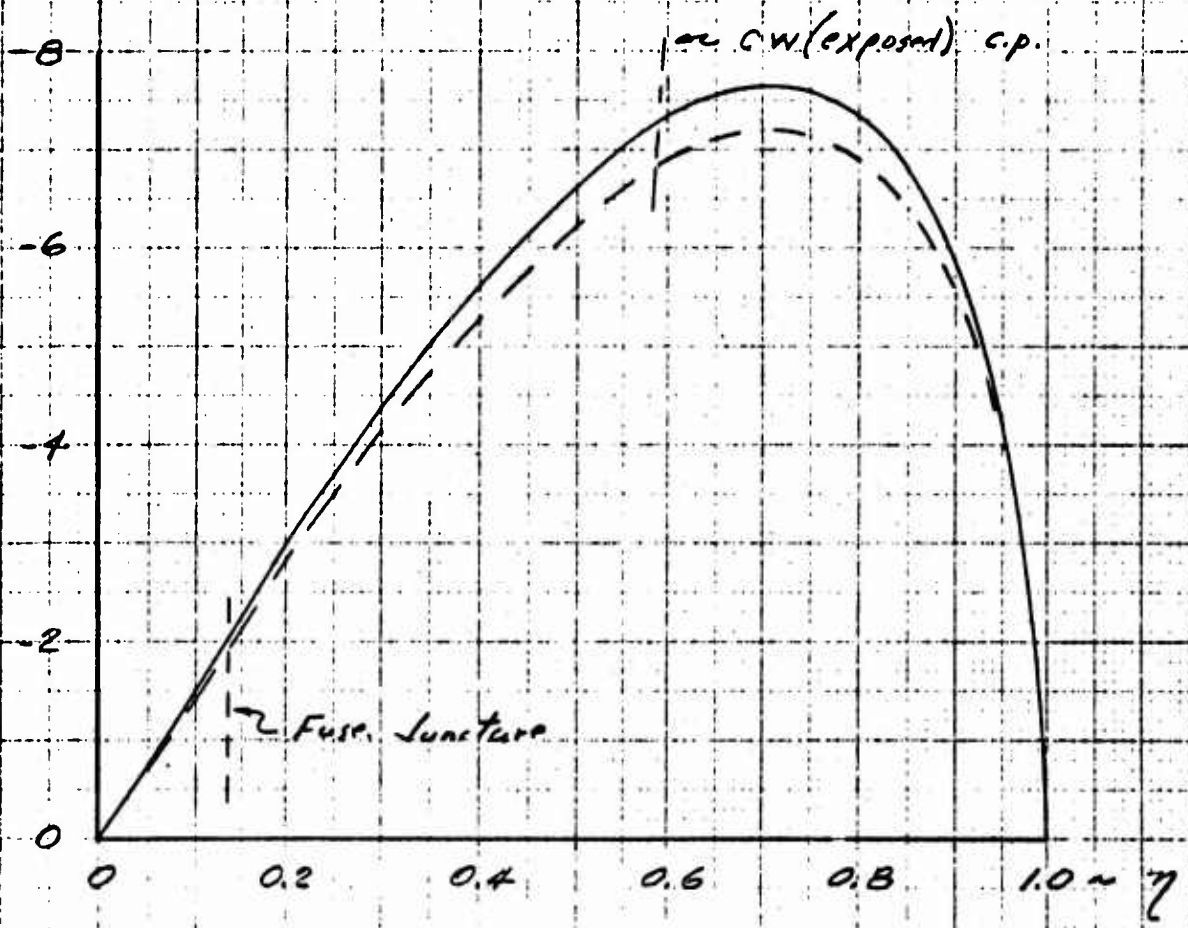

Figure 3.27 Loading Distribution Due to Rolling Velocity

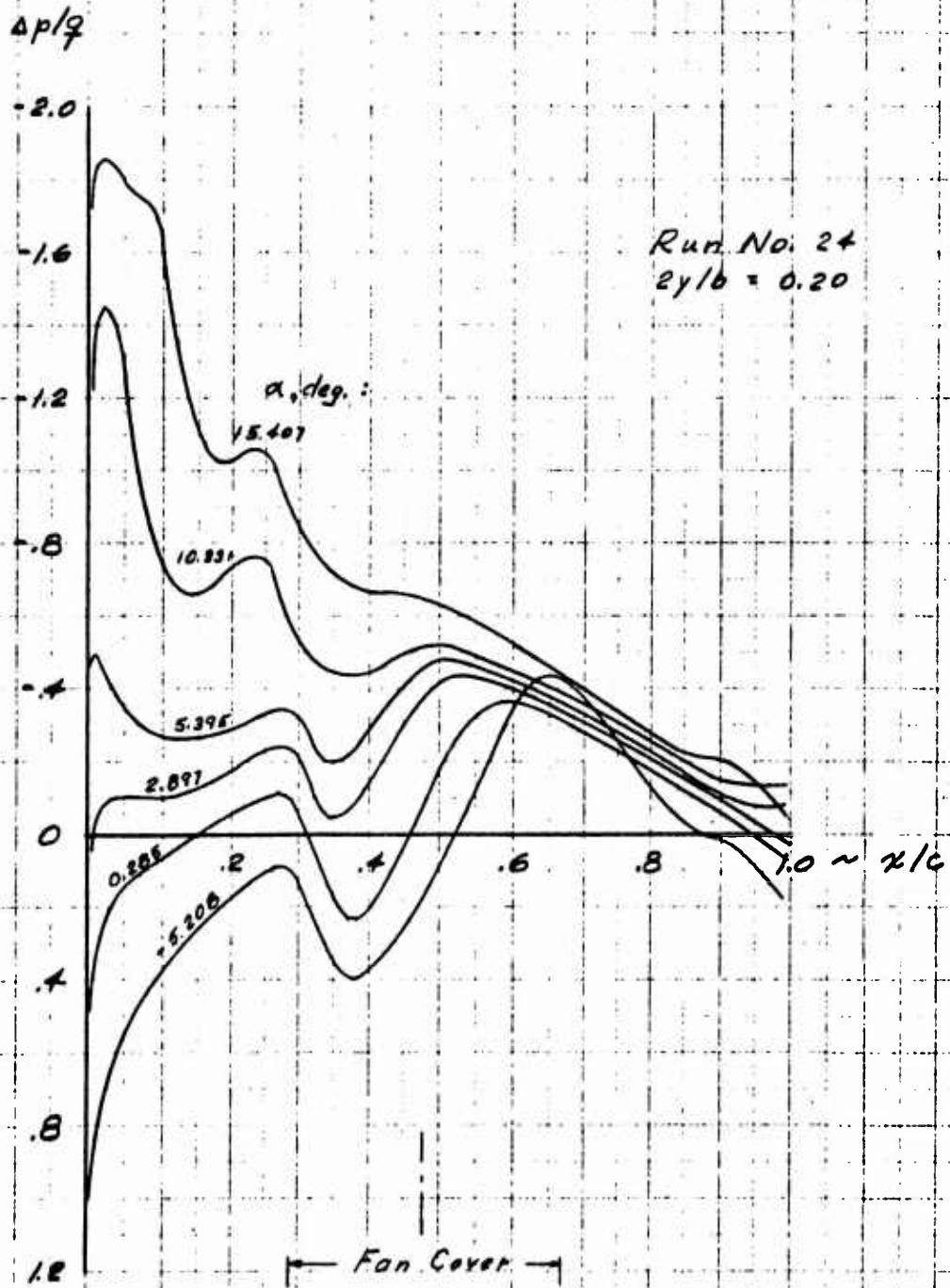

Figure 3.28 Wing Chordwise Pressure Distribution Upper Surface, $M = 0.80$

$\Delta p/q$

2.0

1.6

1.2

.8

.4

0

-.4

-.8

-1.2

Run No. 24
 $2y/b = 0.341$

α , deg.:
15.407

10.931

5.396

0.885

-2.208

x/c

Fan Cover

Figure 3.29 Wing Chordwise Pressure Distribution, Upper Surface, $M=0.80$

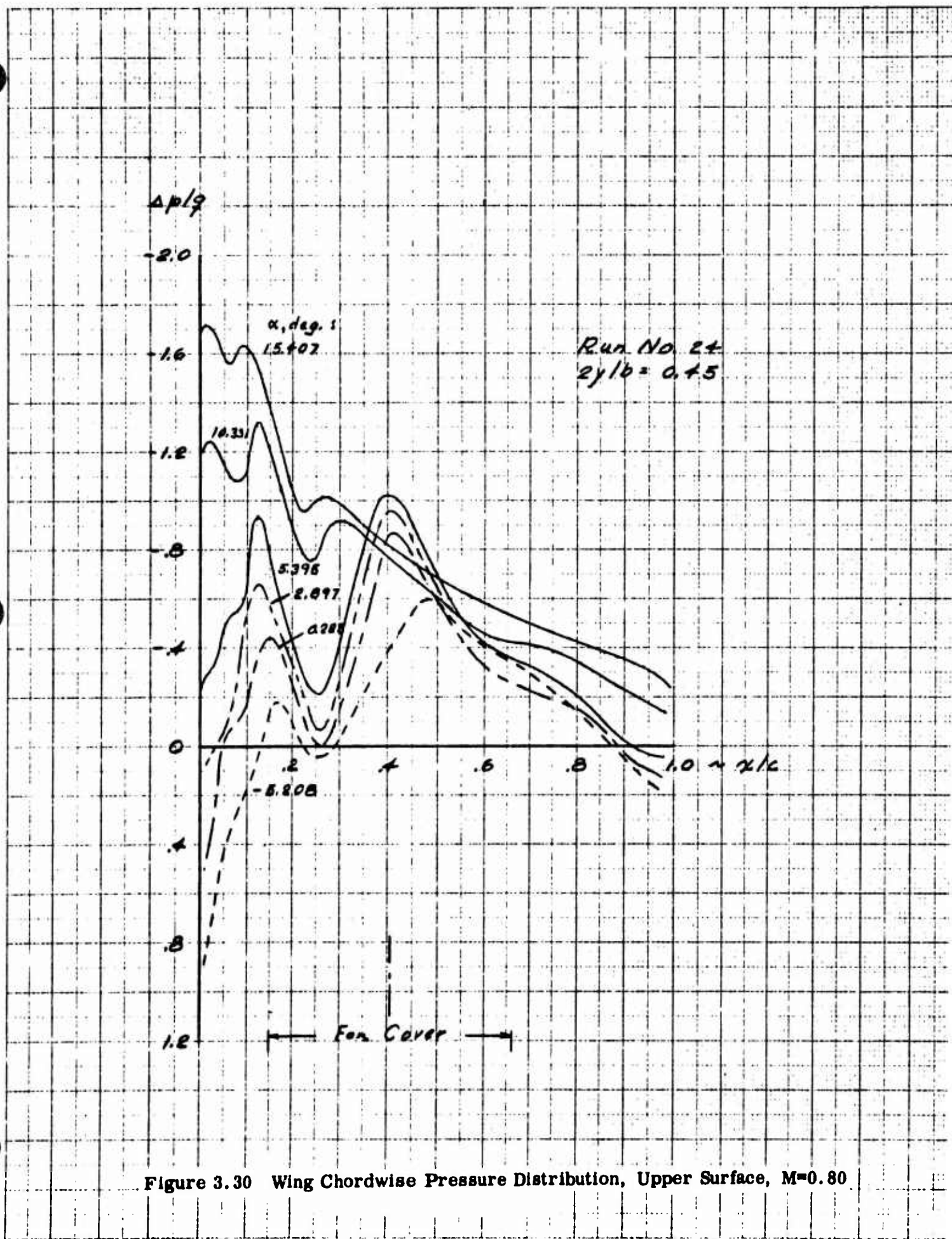

Figure 3.30 Wing Chordwise Pressure Distribution, Upper Surface, $M=0.80$

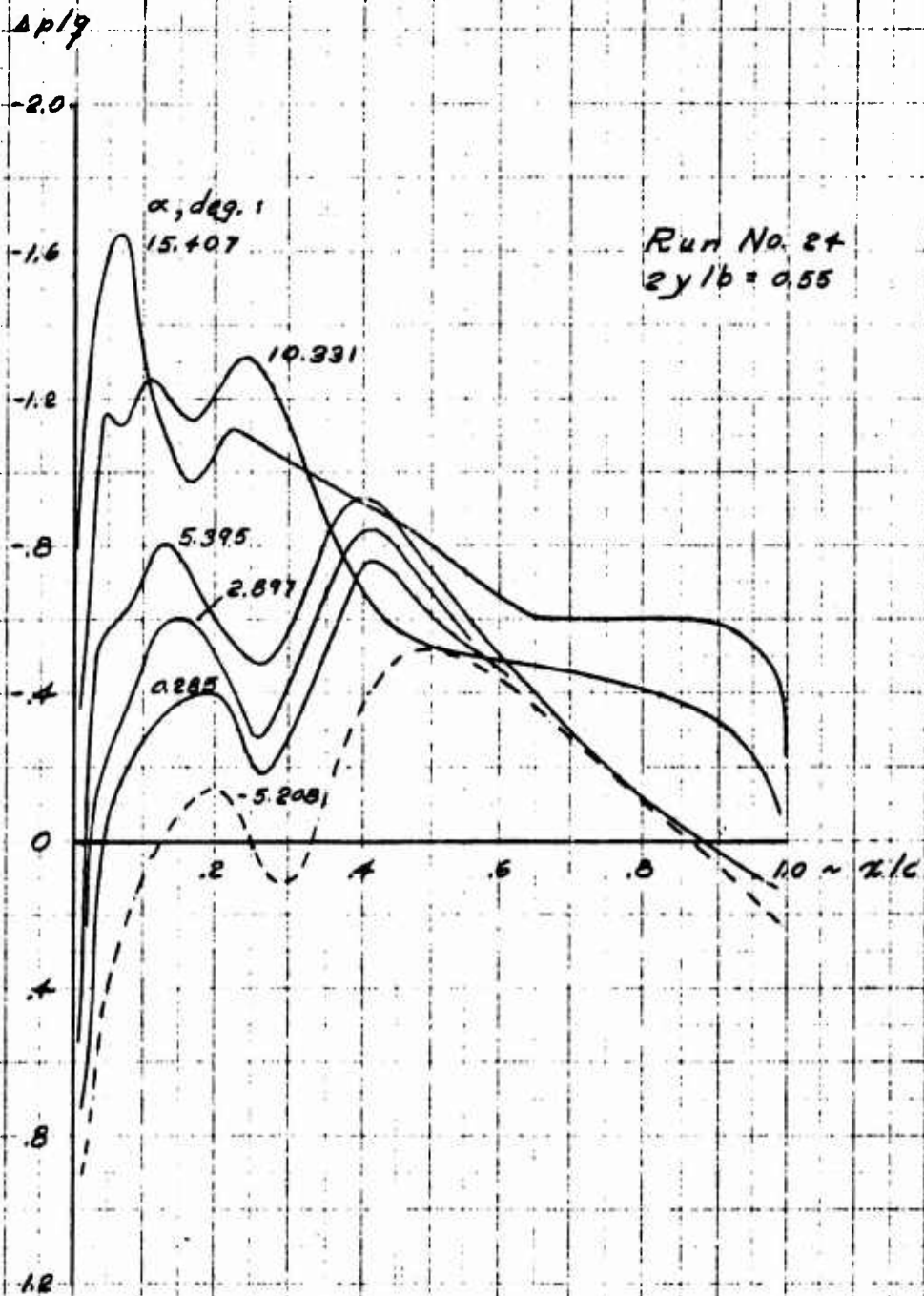

Figure 3.31 Wing Chordwise Pressure Distribution, Upper Surface, $M=0.80$

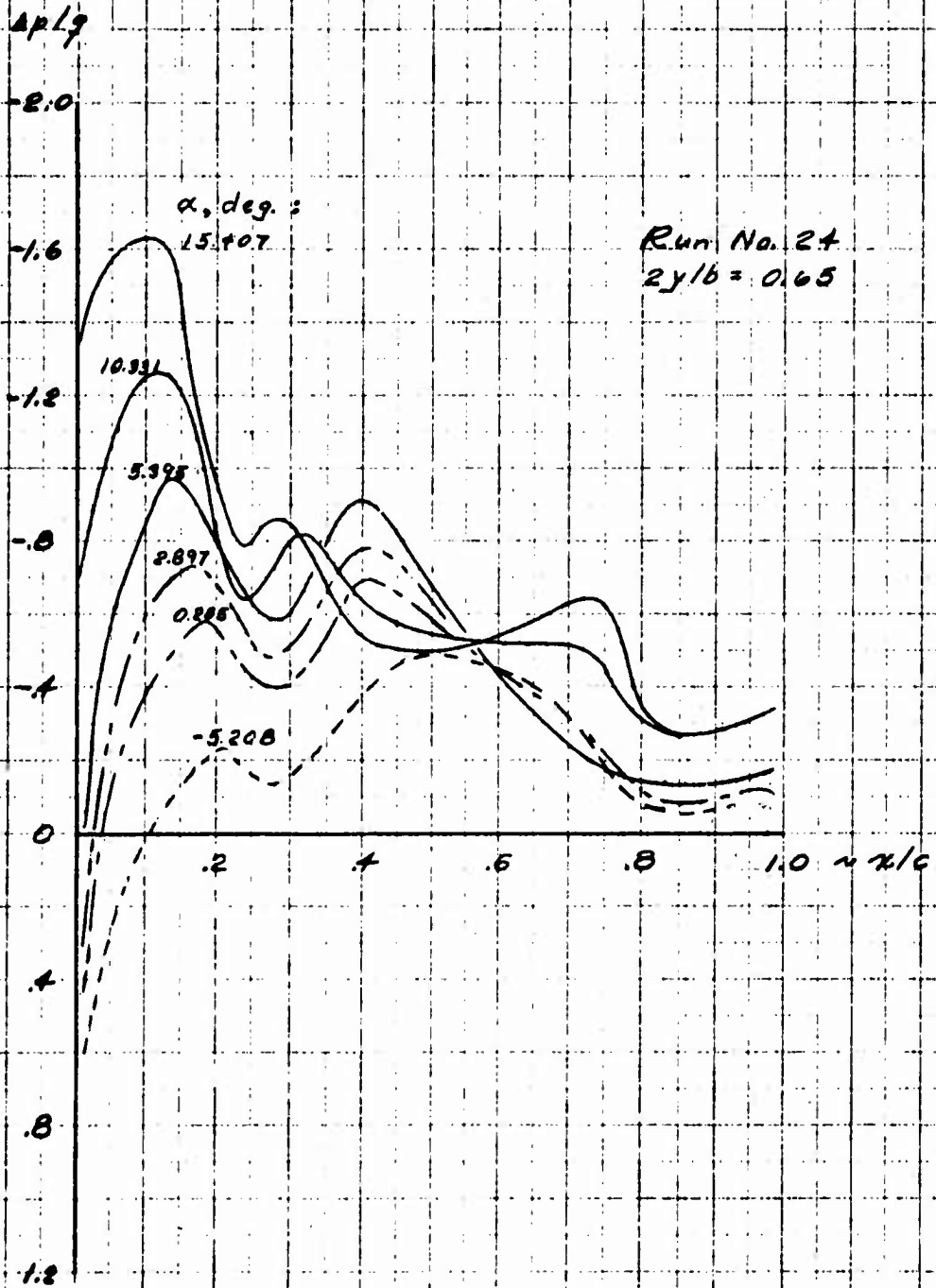

Figure 3.32 Wing Chordwise Pressure Distribution, Upper Surface, $M = 0.80$

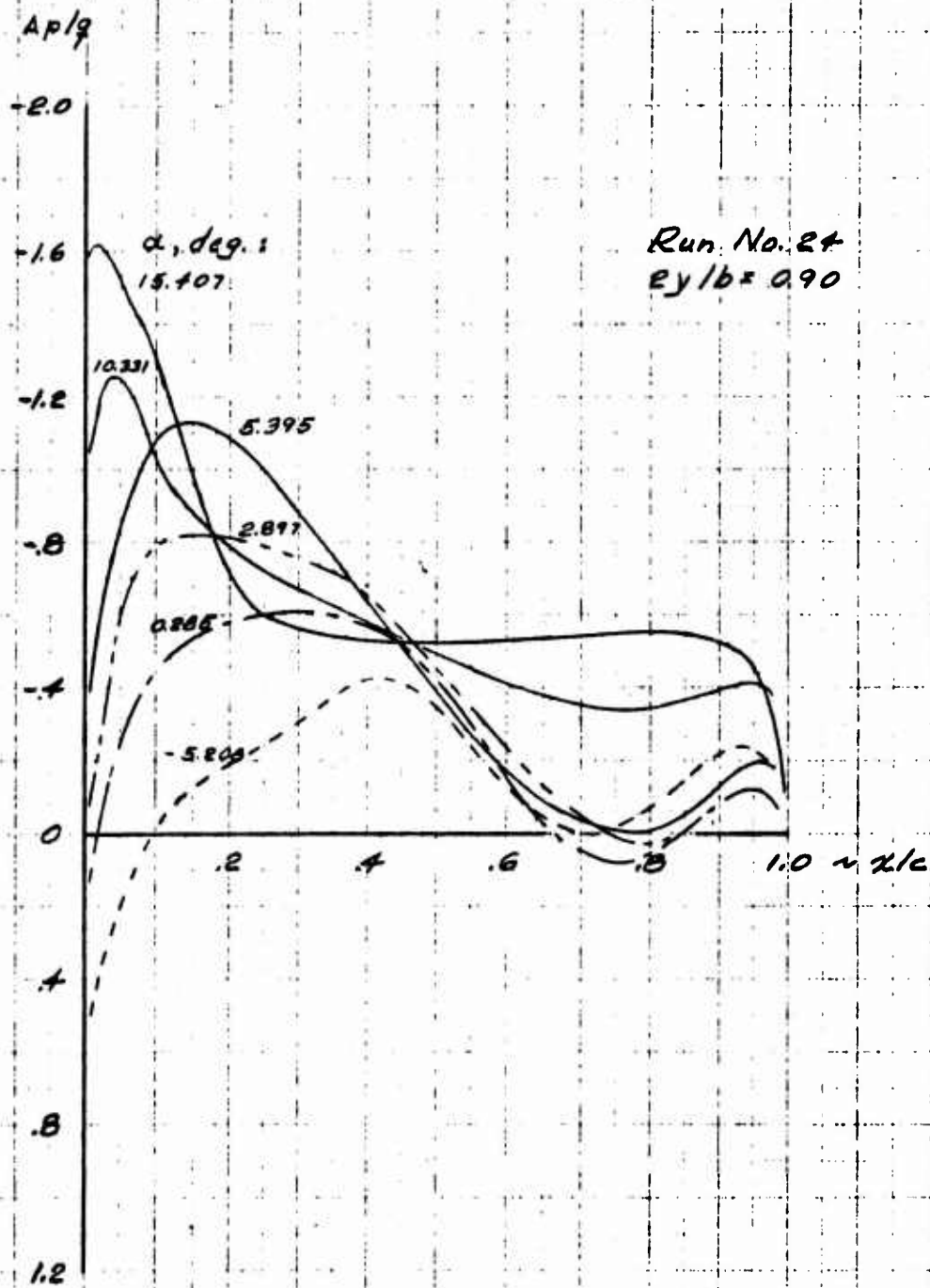

Figure 3.33 Wing Chordwise Pressure Distribution, Upper Surface, $M=0.80$

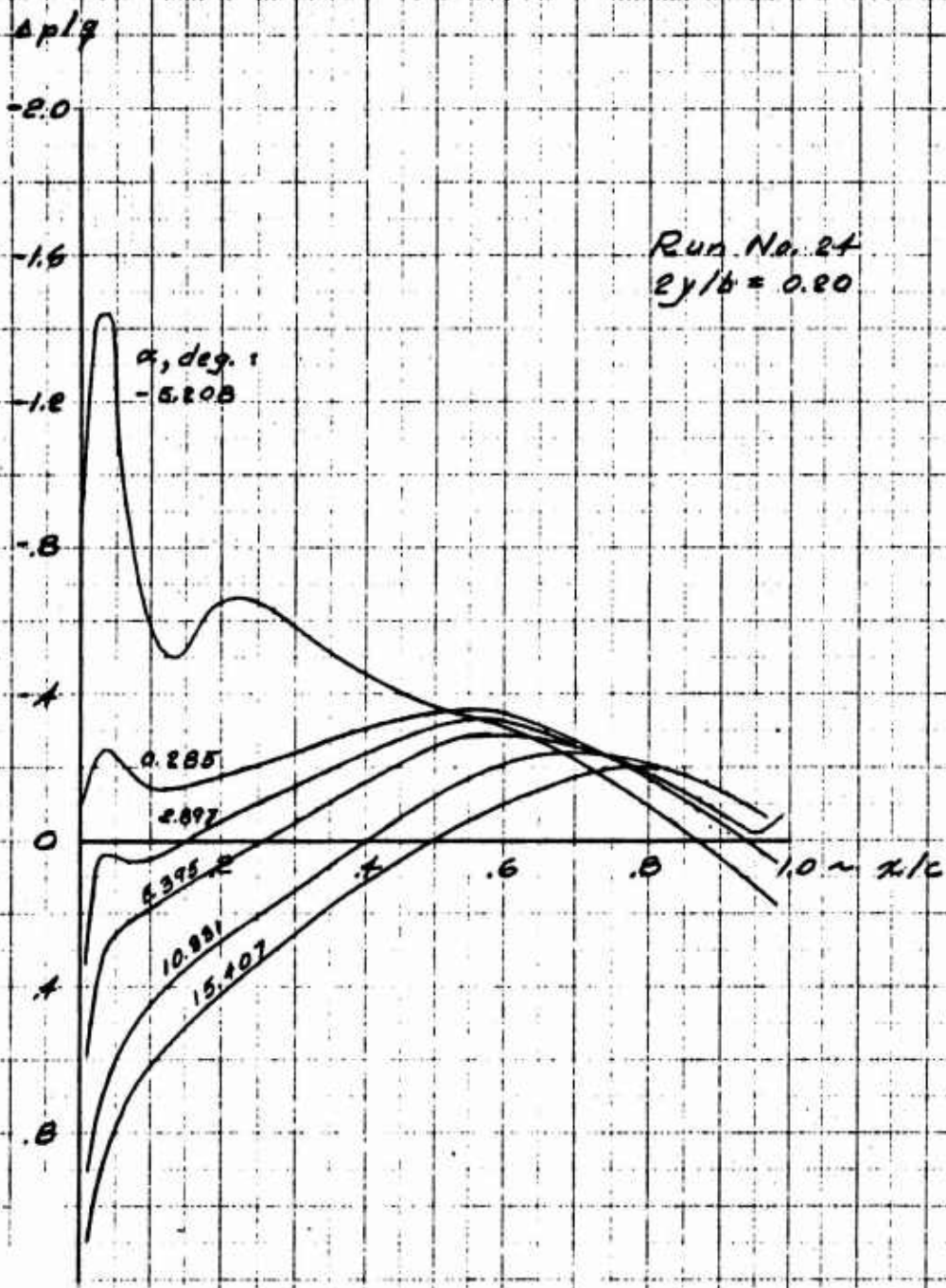

Figure 3.34 Wing Chordwise Pressure Distribution, Lower Surface, $M=0.80$.

Ap/q

-2.0

-1.6

-1.2

-0.8

-0.4

0

0.4

0.8

1.2

Run No. 24
 $2y/b = 0.341$

α , deg.

5.208

0.288

2.897

5.395

10.331

15.407

2.897

10.331

5.395

x/c

Figure 3.35 Wing Chordwise Pressure Distribution, Lower Surface, $M=0.80$

$\Delta p/q$

-2.0
-1.6
-1.2
-.8
-.4
0
.4
.8
1.2

$\alpha, \text{deg.} :$

Run No. 24
 $z/b = 0.45$

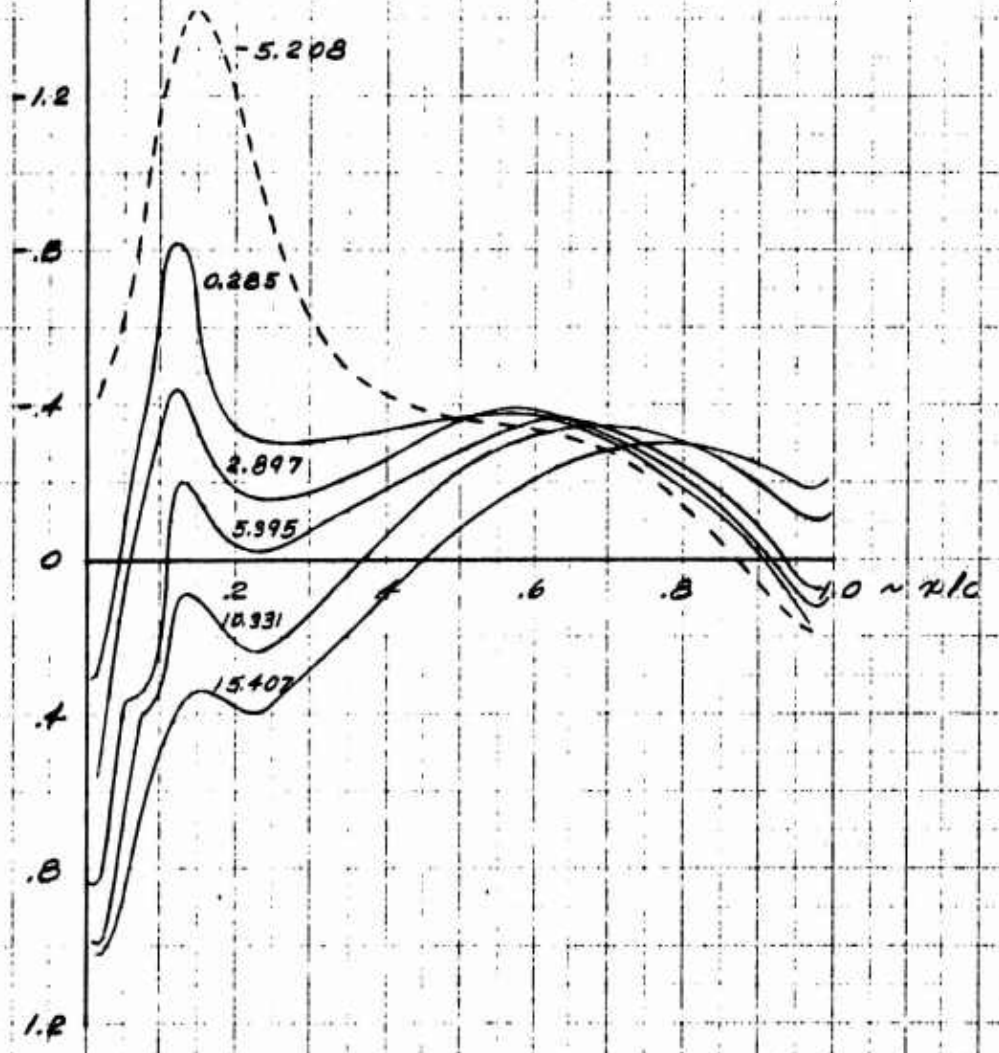

Figure 3.36 Wing Chordwise Pressure Distribution, Lower Surface, $M=0.80$

$\Delta p/q$

2.0

1.6

1.2

.8

.4

0

.4

.8

1.2

Run No. 24
 $2y/b = 0.55$

α , deg.:

5.208

0.285

2.897

5.395

10.331

15.407

.2 .4 .6 .8 1.0 x/c

Figure 3.37 Wing Chordwise Pressure Distribution, Lower Surface, $M=0.80$

$\Delta p/q$

2.0

1.6

1.2

.8

.4

0

.4

.8

1.2

Run No. 24
 $z/b = 0.65$

$\alpha, \text{deg.}$

5.208

0.285

2.897

5.395

10.381

15.102

1.0 $\sim x/c$

Figure 3.38 Wing Chordwise Pressure Distribution, Lower Surface, $M=0.80$

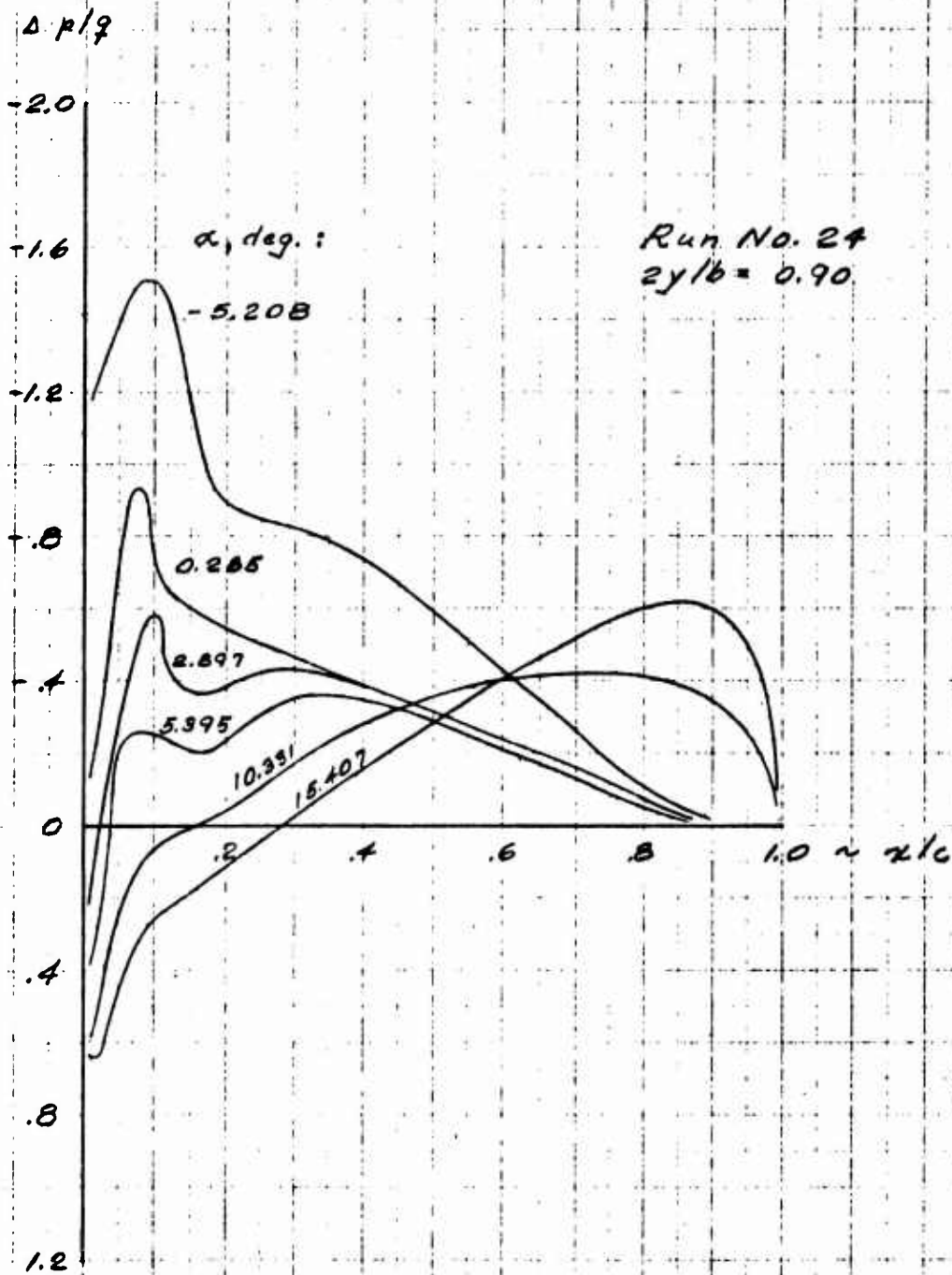

Figure 3.39 Wing Chordwise Pressure Distribution, Lower Surface, $M=0.80$

3.6.2 Fuselage Loading Distribution

Loading on the fuselage represented the combined effects of inertia and external aerodynamic forces. The analysis included weight distributions for the 9200-pound gross weight airplane with respect to both limits of cg (F. Sta. 240 & 246).

To combine all of the distributed and concentrated loads in the many combinations required to define the fuselage loading, a digital computer routine entitled "Fuselage Shear and Moment Program" was devised. Basically, the program combines the effects of (a) fuselage vertical and lateral distributed airloads, (b) fuselage distributed inertia loads produced by linear and angular accelerations, (c) concentrated loads and moments at the landing gear(s) and parachute attachments, (d) wing inertia and airload, (e) empennage inertia and airloads, and (f) engine thrust and ram-drag.

The program applies wing loads, both inertia and aerodynamic, to the fuselage at the fore and aft wing spar locations, Stations 214.0 and 296.5. At the forward wing spar location, vertical and longitudinal loads may be applied as well as concentrated moments about all three axes. At the aft spar, only vertical loads and concentrated moments about the yaw axis may be used by the program. Wing weight data used in the program are:

Weight	2519.86 lbs.
C. G. Station	259.14 inches
C. G. Waterline	101.21 inches
I_{xx}	14,316,246 lb.-in. ²
I_{yy}	4,588,515 lb.-in. ²
I_{zz}	18,351,518 lb.-in. ²
I_{xz}	-16,805 lb.-in. ²

The moment of inertia values given above are with respect to the wing cg.

Empennage loads were applied to the fuselage at the intersections of the three vertical tail spars with W. L. 113.0. These intersections correspond to Fuselage Stations 429.23, 455.22, and 486.39. Vertical and lateral empennage loads, aerodynamic and inertia, were applied to the

center spar and the unbalanced moments reacted as couples between the forward and aft spar locations. Empennage rolling moments were applied to the fuselage at the center spar location, Station 455.22. Empennage weight data used in the program are:

Weight	223.21 lbs.
C. G. Station	491.91 inches
C. G. Waterline	181.47 inches
I_{xx}	327,606 lb.-in. ²
I_{yy}	284,623 lb.-in. ²
I_{zz}	253,843 lb.-in. ²
I_{xz}	64,809.8 lb.-in. ²

The moments of inertia values given above are with respect to empennage cg.

Concentrated loads are accepted by the program at locations of the nose gear, main gear and parachute attachments. Three (3) components of force and moment may be applied to the fuselage at Station 486.39 and W. L. 113.0 for parachute conditions.

Nose gear forces, acting along any of the three body axes, are assumed applied at Station 135.312 and W. L. 29.3 by the program. Gear side loads act on the fuselage only at Station 136.5. Vertical and longitudinal loads are assumed reacted at two points in the fuselage, one located at Station 110.0, W. L. 86.5 and the other at Station 136.5, W. L. 74.0.

The main gear loads were assumed to act at the apex of the tripods situated at F. S. 275.65, W. L. 37.0, and B. L. ± 51.0 . Three (3) component forces and moments may be applied at these points. A redundant solution of the distribution of main gear loads in the three arms of the tripod is presented in Reference 7. For the fuselage shear and moment program, the main gear loads are distributed to the fuselage at two points (1) F. S. 286.0, W. L. 96.0, and (2) F. S. 315.89, W. L. 96.0.

3.6.2.1 Inertial Distribution

Two distributions of fuselage weight were used in the analyses. One results in an airplane c. g. at Fuselage Station 240 and the other at 246.

In order to simplify fuselage stress analyses it was desired that fuselage loading be available at specified fuselage stations. These are stations which correspond to locations of bulkheads, landing gear fittings, spar attachments, etc. Fuselage weights data, available in 10 inch increments, were modified by a digital computer routine. The routine combines basic fuselage, wing, and empennage weight distributions, multiplying each by factors, to obtain distributions with the desired weight and c.g. locations. Each such result is interpolated to produce output at the desired stress stations. The output consists of not only weight, but of moments of inertia about the airplane X, Y, and Z axes and of the product of inertia I_{xz} . The two weight distributions used are listed in Tables 3.3 and 3.4, and in Figure 3.40.

3.6.2.2 Aerodynamic Distribution

Fuselage wind-tunnel pressure data is available for Mach numbers of .4 to .9. (Reference 5). The majority of the pressure orifices which could be used in defining the vertical component of airload were located on the plane of symmetry at B. L. = 0. At those stations where pressures were measured at B. L. locations other than zero, the circumferential pressure distributions were plotted versus B. L. and were integrated to determine the local running load. This value of running load was compared with the value obtained by assuming the pressure at the plane of symmetry to act uniformly across the width of the fuselage. The ratio of these two values was assumed to hold for other fuselage stations where only centerline pressure orifices were located.

The fuselage vertical running load distribution was determined by fairing through the available data points considering also the fuselage profile and the aerodynamic lift and pitching moments indicated by wind-tunnel force measurements.

The effect of engine operation upon fuselage pressure was available only at the inlet area and not in the vicinity of the tailpipe exhaust. It is likely, however, that the exhaust will affect the pressure immediately aft of the nozzle exit plane. The effect of the jet exhaust on this pressure field was assumed similar to the effect of the engine intake air at low speed upon canopy pressures. It was thus considered that the exhaust causes a large negative pressure peak immediately aft of the nozzle exits. Since the effect of engine operation upon fuselage pressure diminishes rapidly with speed, only a low speed condition has been investigated.

At high angles-of-attack for use with spin conditions an estimate of the fuselage vertical airload distribution was made on the basis of an equivalent circular cylinder.

The fuselage running loads resulting from the vertical component of airloads are shown in Figures 3.41 through 3.45.

Fuselage side airload distributions were determined in somewhat the same manner. Pressure orifices were located only on one side of the fuselage of the wind-tunnel model, mostly at or near waterline (W. L.) 90.0. Pressure measurements, however, were made at both plus and minus angles of sideslip.

Lengthwise pressure distribution curves were constructed along those waterlines for which data were available. These lengthwise distributions were then utilized to determine the circumferential pressure distributions at various fuselage stations. Integration of the local pressures across the height of the fuselage yielded values for the running load. The fairing of this curve was performed with consideration of the side force and yawing moment values measured during wind-tunnel tests.

The fuselage side airload distribution used in the analyses is shown in Figure 3.46.

At high angles of attack for use with spin conditions, an estimate of the fuselage vertical airload distribution was made on the basis of an equivalent circular cylinder.

FUSELAGE SHEAR AND MOMENT PROGRAM - JOB NUMBER 1105 - 11 NOV 1963

DEAD WEIGHT DISTRIBUTION 1

NO	F.A.S.	WEIGHT	X ARM	Z ARM	I (X)	I (Y)	I (Z)	I (X,Y)	I (X,Z)	I (Y,Z)
1	-70.00	0.6059999E 00	-2.93384415E 01	0.0391310E 01	0.7214012E 01	0.2566257E 03	0.25480437E 03	0.0	0.0	0.0
2	0.0	1.5070000E 01	-7.83114835E 00	9.02468596E 01	5.3344599E 02	8.4689230E 03	8.5244833E 03	5.3510151E 02	5.3510151E 02	5.3510151E 02
3	20.00	1.5758456E 01	-4.36815565E 01	9.2786756E 01	1.1907176E 03	1.2668700E 04	1.2066926E 04	7.1096469E 02	7.1096469E 02	7.1096469E 02
4	47.00	5.7721152E 01	2.6782515E 01	9.5337731E 01	1.3240609E 04	4.7109795E 04	4.8622805E 04	2.8629796E 03	2.8629796E 03	2.8629796E 03
5	59.00	1.0418371E 02	4.4466161E 01	9.7556624E 01	1.0526449E 04	7.9755615E 04	1.1345101E 05	1.0015662E 04	1.0015662E 04	1.0015662E 04
7	71.00	2.1127155E 02	5.0061235E 01	9.7608255E 01	9.7569399E 04	1.3018564E 05	1.5281127E 05	1.0458875E 04	1.0458875E 04	1.0458875E 04
6	82.60	2.6519145E 02	5.5611924E 01	9.7609222E 01	1.1472047E 05	1.7037278E 05	1.9587443E 05	6.3540076E 03	6.3540076E 03	6.3540076E 03
9	91.00	3.0178475E 02	5.9745306E 01	9.6728325E 01	1.277395E 05	2.0996534E 05	2.3440153E 05	5.0131590E 04	5.0131590E 04	5.0131590E 04
10	110.00	4.6001926E 02	7.4251534E 01	9.8535649E 01	1.9234356E 05	4.5252941E 05	4.7516164E 05	2.6650550E 04	2.6650550E 04	2.6650550E 04
11	122.50	5.6003051E 02	8.2604421E 01	9.8536375E 01	2.586661E 05	6.7307074E 05	6.3524970E 05	4.4014509E 04	4.4014509E 04	4.4014509E 04
12	150.50	9.077394E 02	1.0000707E 02	1.0000707E 02	2.5274845E 05	1.3014917E 06	1.152618E 06	1.3660719E 05	1.3660719E 05	1.3660719E 05
13	150.00	1.3546100E 03	1.0146094E 02	1.0366761E 02	6.9450609E 05	2.0319035E 06	1.6026514E 06	2.6816897E 05	2.6816897E 05	2.6816897E 05
14	165.20	1.6061452E 03	1.2039431E 02	1.0336920E 02	7.5670186E 05	2.4330560E 06	2.1624235E 06	2.5118528E 05	2.5118528E 05	2.5118528E 05
12	171.20	1.975806E 03	1.6299483E 02	1.0356417E 02	9.5286770E 05	5.2869837E 06	2.9383073E 06	2.6318431E 05	2.6318431E 05	2.6318431E 05
16	180.50	2.415507E 03	1.959111E 02	1.0050507E 02	1.0050507E 02	4.4365010E 06	4.0384603E 06	3.6509972E 05	3.6509972E 05	3.6509972E 05
17	201.90	2.6610994E 03	1.6447435E 02	1.0718955E 02	1.0718955E 02	5.1026637E 06	4.7426209E 06	4.5723168E 05	4.5723168E 05	4.5723168E 05
18	210.00	3.0007645E 03	1.520659E 02	1.0939765E 02	1.0939765E 02	6.763370E 06	6.0755102E 06	6.4935324E 05	6.4935324E 05	6.4935324E 05
19	260.00	4.721059E 03	1.6942960E 02	1.1669320E 02	2.5612771E 06	1.610754E 07	1.6344965E 07	2.5643533E 06	2.5643533E 06	2.5643533E 06
20	287.00	5.029601E 03	1.917394E 02	1.1675347E 02	3.0761826E 06	2.126642E 07	1.967664E 07	2.601954E 06	2.601954E 06	2.601954E 06
21	290.50	5.382552E 03	1.967428E 02	1.1657967E 02	3.1649632E 06	2.3057897E 07	2.3444012E 07	2.5089957E 06	2.5089957E 06	2.5089957E 06
22	315.09	5.77455E 03	2.063023E 02	1.163420E 02	3.566672E 06	2.9660258E 07	2.6011893E 07	2.244289E 06	2.244289E 06	2.244289E 06
23	320.10	5.664604E 03	2.003678E 02	1.1595921E 02	3.553575E 06	3.110616E 07	2.9411605E 07	2.120345E 06	2.120345E 06	2.120345E 06
24	341.00	5.952670E 03	2.1111845E 02	1.1578455E 02	3.407217E 06	3.4243718E 07	3.0717350E 07	1.9901912E 06	1.9901912E 06	1.9901912E 06
25	360.00	6.172345E 03	2.1481760E 02	1.1526161E 02	3.5427563E 06	3.6495441E 07	3.4315712E 07	1.547589E 06	1.547589E 06	1.547589E 06
26	392.12	6.252799E 03	2.1692664E 02	1.1513209E 02	3.5527983E 06	3.6683003E 07	3.6807626E 07	1.415623E 06	1.415623E 06	1.415623E 06
27	407.00	6.294626E 03	2.1813239E 02	1.1507002E 02	3.6617166E 06	4.0003239E 07	3.8261455E 07	1.5458775E 06	1.5458775E 06	1.5458775E 06
26	419.00	6.3350735E 03	2.1940325E 02	1.1497465E 02	3.7125726E 06	4.1647510E 07	3.9934207E 07	1.226237E 06	1.226237E 06	1.226237E 06
29	429.23	6.3624668E 03	2.2026416E 02	1.1492387E 02	3.723629E 06	4.2771503E 07	4.0952151E 07	1.162686E 06	1.162686E 06	1.162686E 06
30	440.53	6.3896221E 03	2.2119635E 02	1.1482787E 02	3.7350702E 06	4.4070005E 07	4.2253162E 07	1.1663354E 06	1.1663354E 06	1.1663354E 06
31	455.22	6.397669E 03	2.2155504E 02	1.147839E 02	3.7353673E 06	4.4598553E 07	4.2716690E 07	1.1691336E 06	1.1691336E 06	1.1691336E 06
32	470.80	6.4211760E 03	2.2235606E 02	1.1492741E 02	3.7598514E 06	4.5832925E 07	4.4013057E 07	1.1677243E 06	1.1677243E 06	1.1677243E 06
33	486.38	6.445875E 03	2.2312572E 02	1.1492741E 02	3.7429316E 06	4.7102547E 07	4.583128E 07	1.163128E 06	1.163128E 06	1.163128E 06
34	500.30	6.450252E 03	2.2352572E 02	1.1492741E 02	3.7429316E 06	4.7102547E 07	4.583128E 07	1.163128E 06	1.163128E 06	1.163128E 06
35	520.00	6.456292E 03	2.2382619E 02	1.1492039E 02	3.7427147E 06	4.8346434E 07	4.6526031E 07	1.1554124E 06	1.1554124E 06	1.1554124E 06

Table 3.3 XV-5A Fuselage Weight Distribution Forward Center-of-Gravity Location

FUSELAGE SHEAR AND MOMENT PROGRAM - JOB NUMBER 1105 - 11 NOV 1963

DEAD WEIGHT DISTRIBUTION 2

NO	FaSa	HEIGHT	X ARM	Z ARM	I(X)	I(Y)	I(Z)	I(XZ)
1	-70.00	0.	0.	0.	0.	0.	0.	0.
2	0.	6.6039999E 00	-2.9364415E 01	9.60351310E 01	2.7214012E 02	2.5762377E 02	2.5760037E 03	-3.6652123E 00
3	20.00	1.5673000E 01	-1.03114859E 00	9.2468596E 01	5.3345559E 02	6.0069350E 03	5.5744633E 03	5.3510151E 02
4	35.00	1.9770600E 01	4.3613500E 01	9.2766796E 01	1.1907176E 03	1.2683540E 04	1.2636926E 04	7.1096869E 02
5	47.00	5.7721102E 01	2.6752515E 01	9.3537791E 01	4.8710975E 04	4.8710975E 04	4.8662703E 04	2.6275052E 03
6	53.00	1.4103351E 02	4.4406016E 01	9.4256624E 01	6.0626442E 04	9.9755915E 04	1.1345201E 05	1.0015662E 04
7	71.00	2.1127121E 02	5.0061235E 01	9.7608259E 01	9.7569399E 04	1.3031836E 05	1.5281127E 05	1.0436475E 04
8	82.60	2.6515145E 02	5.5011759E 01	9.7260727E 01	1.1472047E 05	1.8703747E 05	1.9507745E 05	6.5540076E 03
9	91.00	3.05176475E 02	5.7453367E 01	9.6726339E 01	1.2773395E 05	2.0996934E 05	2.3540153E 05	4.0131590E 03
10	110.00	4.6591790E 02	7.4231304E 01	9.6035064E 01	1.9134356E 05	4.5252741E 05	4.4716184E 05	2.0030250E 04
11	122.50	5.6655051E 02	8.2554029E 01	9.6035037E 01	2.5563001E 05	6.7507094E 05	6.5354970E 05	4.4014509E 04
12	136.50	6.8277244E 02	9.0040709E 02	1.0211094E 02	4.5212645E 05	1.3014917E 06	1.1952318E 06	1.2660713E 05
13	150.00	1.03948100E 03	1.1452749E 02	1.0556678E 02	6.7430602E 05	2.4031503E 06	1.6620014E 06	2.6610097E 05
14	165.20	1.5900669E 03	1.2017355E 02	1.0536661E 02	7.5784022E 05	2.4164499E 06	2.1071126E 06	2.4986274E 05
15	177.20	2.0879452E 03	1.2021752E 02	1.0545279E 02	8.5072747E 05	3.1515720E 06	2.6000917E 06	2.5460502E 05
16	180.90	2.2470004E 03	1.3064303E 02	1.0540670E 02	9.5043623E 05	4.1736742E 06	3.7735017E 06	3.0571216E 05
17	201.50	2.4410000E 03	1.4477359E 02	1.0571621E 02	1.0993796E 06	4.7711415E 06	4.5004035E 06	4.5723161E 05
18	214.00	2.6507457E 03	1.4702023E 02	1.0574569E 02	1.3085374E 06	6.0692297E 06	5.4520292E 06	5.4542136E 05
19	260.00	4.3626945E 03	1.6541760E 02	1.1742805E 02	2.9408656E 06	1.4817676E 07	1.6636465E 07	2.5758526E 06
20	267.00	4.7039023E 03	1.6925944E 02	1.1749957E 02	3.0376550E 06	2.1495433E 07	1.9922609E 07	2.6304484E 06
21	290.50	5.0751134E 03	2.0013660E 02	1.1729026E 02	3.1295306E 06	2.5507042E 07	2.3110484E 07	2.9513711E 06
22	315.65	5.4671322E 03	2.3080305E 02	1.1677912E 02	3.2560014E 06	2.9602190E 07	2.4947406E 07	2.2431300E 06
23	326.10	5.5777473E 03	2.1020945E 02	1.1659279E 02	3.3321301E 06	3.1240179E 07	2.9555095E 07	2.1277046E 06
24	341.00	5.8072217E 03	2.1233233E 02	1.1654505E 02	3.3520305E 06	3.3125450E 07	3.1952226E 07	2.0949355E 06
25	360.00	6.1394355E 03	2.2203977E 02	1.1658006E 02	3.6143303E 06	4.1255932E 07	3.9426100E 07	4.1279015E 06
26	372.10	6.2273500E 03	2.2575666E 02	1.1652509E 02	3.6798948E 06	4.4052322E 07	4.2191173E 07	2.0680193E 06
27	397.00	6.8246020E 03	2.2052179E 02	1.1645177E 02	3.7659732E 06	4.5209771E 07	4.3295544E 07	1.9915414E 06
28	419.00	6.3356730E 03	2.2011300E 02	1.1634745E 02	3.8035602E 06	4.6875263E 07	4.4470000E 07	1.8668413E 06
29	425.23	6.3824605E 03	2.261402E 02	1.1629039E 02	3.8148900E 06	4.770401E 07	4.5895655E 07	1.7586119E 06
30	440.25	6.386221E 03	2.2963664E 02	1.1626934E 02	3.8239786E 06	4.8362306E 07	4.702930E 07	1.7923280E 06
31	455.22	6.397766E 03	2.3016035E 02	1.1626744E 02	3.8263051E 06	4.9472031E 07	4.7322672E 07	1.7541153E 06
32	470.60	6.4211758E 03	2.3092599E 02	1.1628193E 02	3.8366257E 06	5.0619635E 07	4.8730153E 07	1.7620274E 06
33	486.39	6.4494916E 03	2.3162620E 02	1.1627519E 02	3.8399477E 06	5.1805266E 07	4.915746E 07	1.7751459E 06
34	500.00	6.4506291E 03	2.3219402E 02	1.1627075E 02	3.8336952E 06	5.2487512E 07	5.0387451E 07	1.767362E 06
35	520.00	6.4569290E 03	2.3237515E 02	1.1626741E 02	3.8333676E 06	5.2975655E 07	5.1063451E 07	1.7617502E 06

Table 3.4 XV-5A Fuselage Weight Distribution Air Center-of-Gravity Location

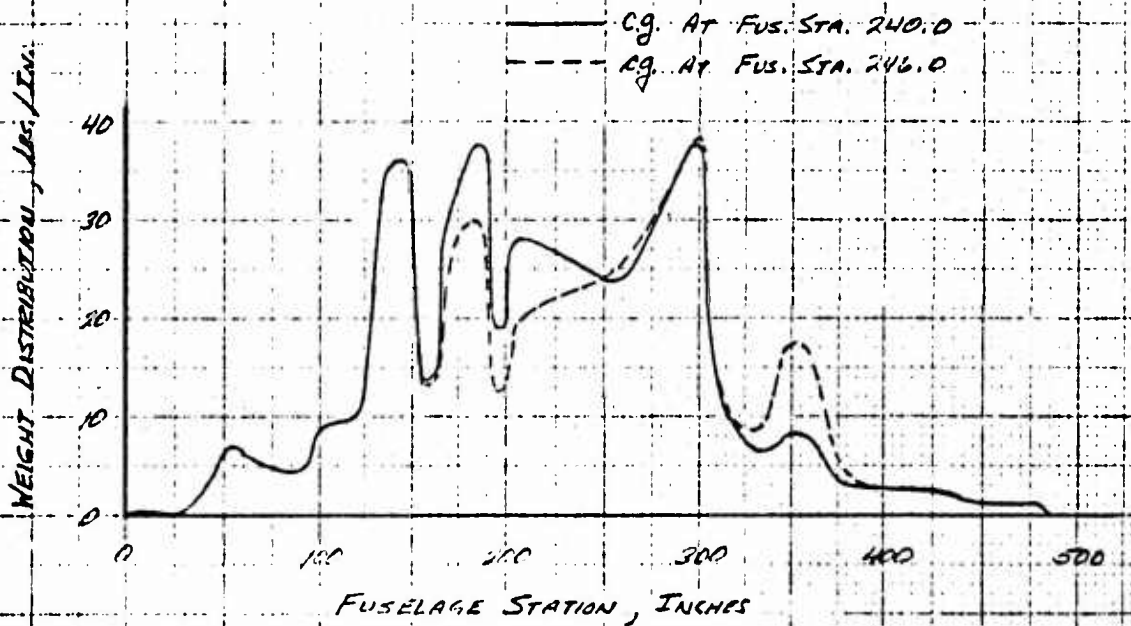
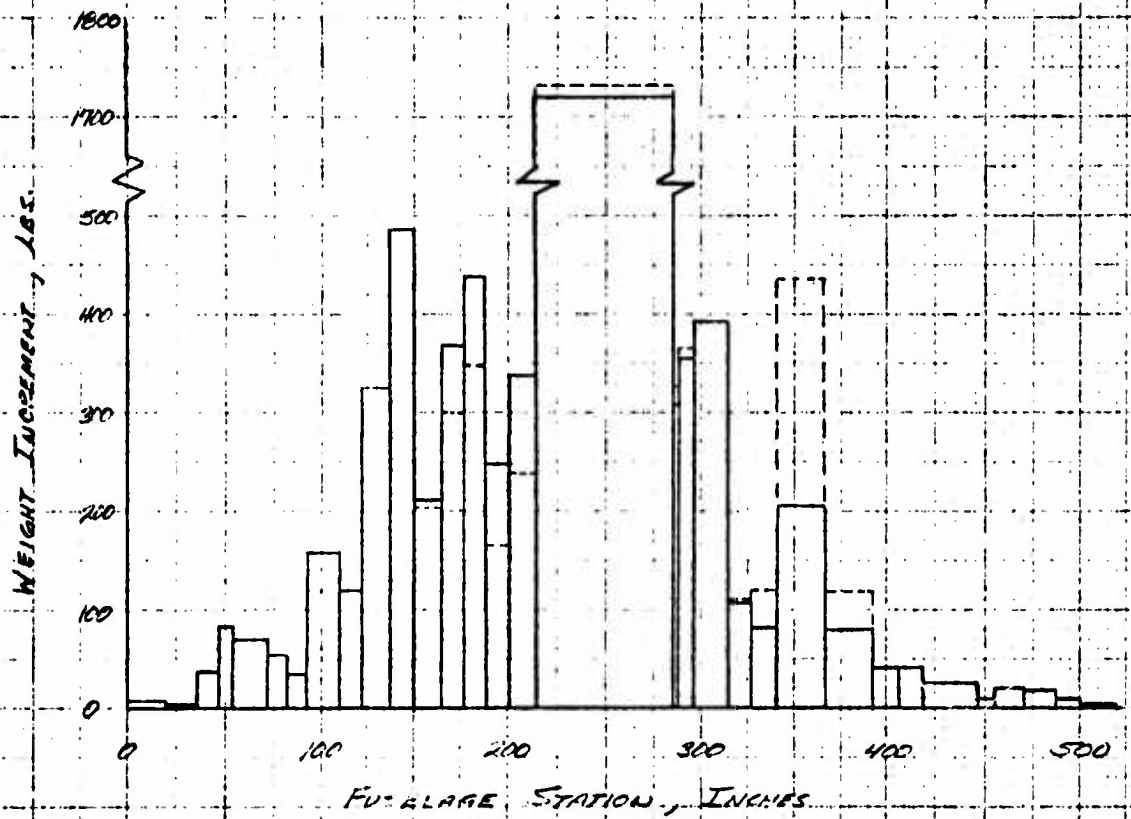

Figure 3.40 Fuselage Weight Distribution

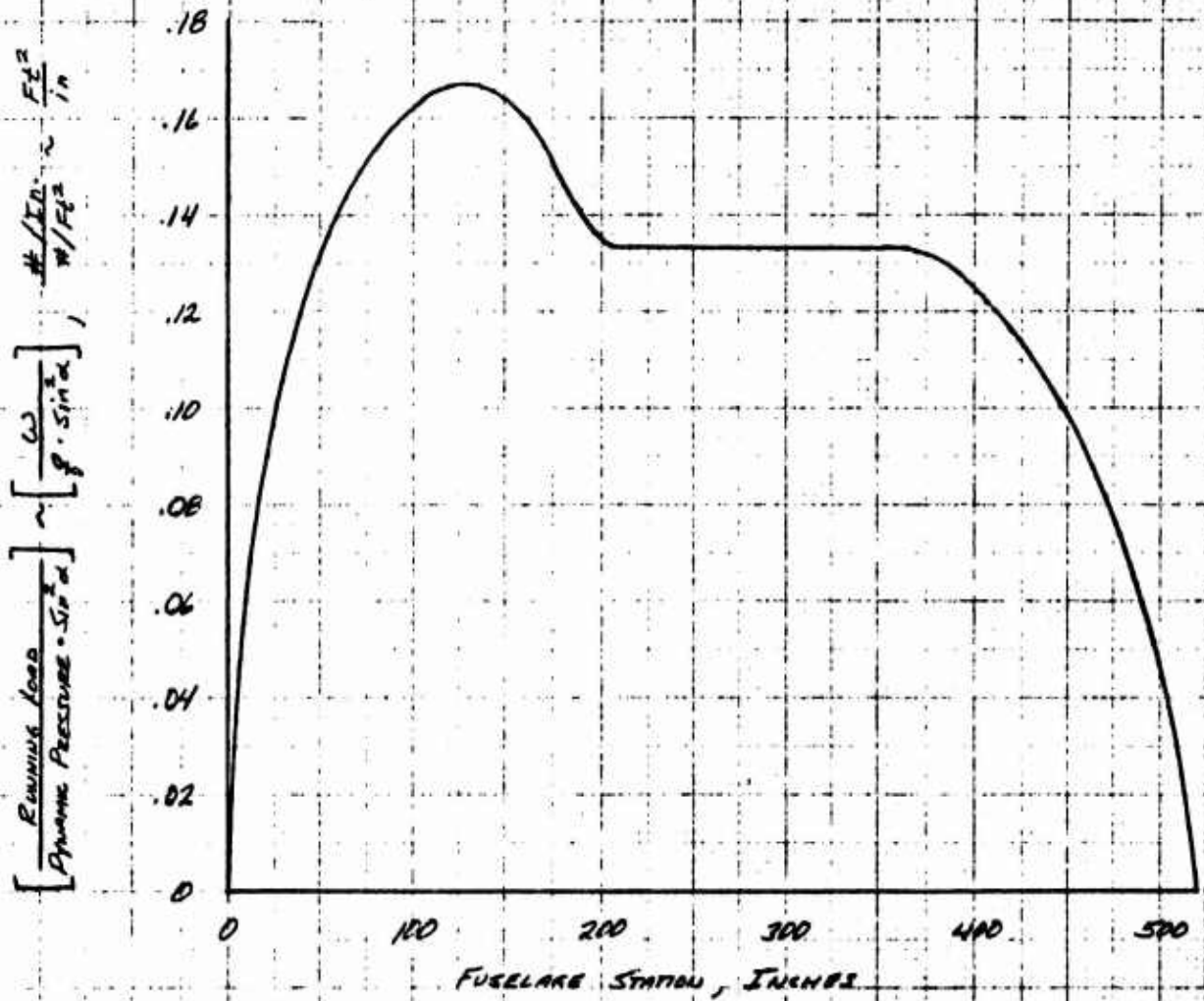

Figure 3.41 Fuselage Vertical Airload Distribution Low Speed, High Angles-of-Attack

POWER OFF & ON
 FUSELAGE IN PRESENCE OF WING
 LOW SPEED, $MN \approx 0.3$
 $\alpha = 0^\circ$, $\gamma = 0^\circ$

NOTE: ASSUME POWER-ON LOADING
 IS COINCIDENT WITH POWER
 OFF VALUES UNLESS OTHERWISE
 INDICATED BY DASHED LINES

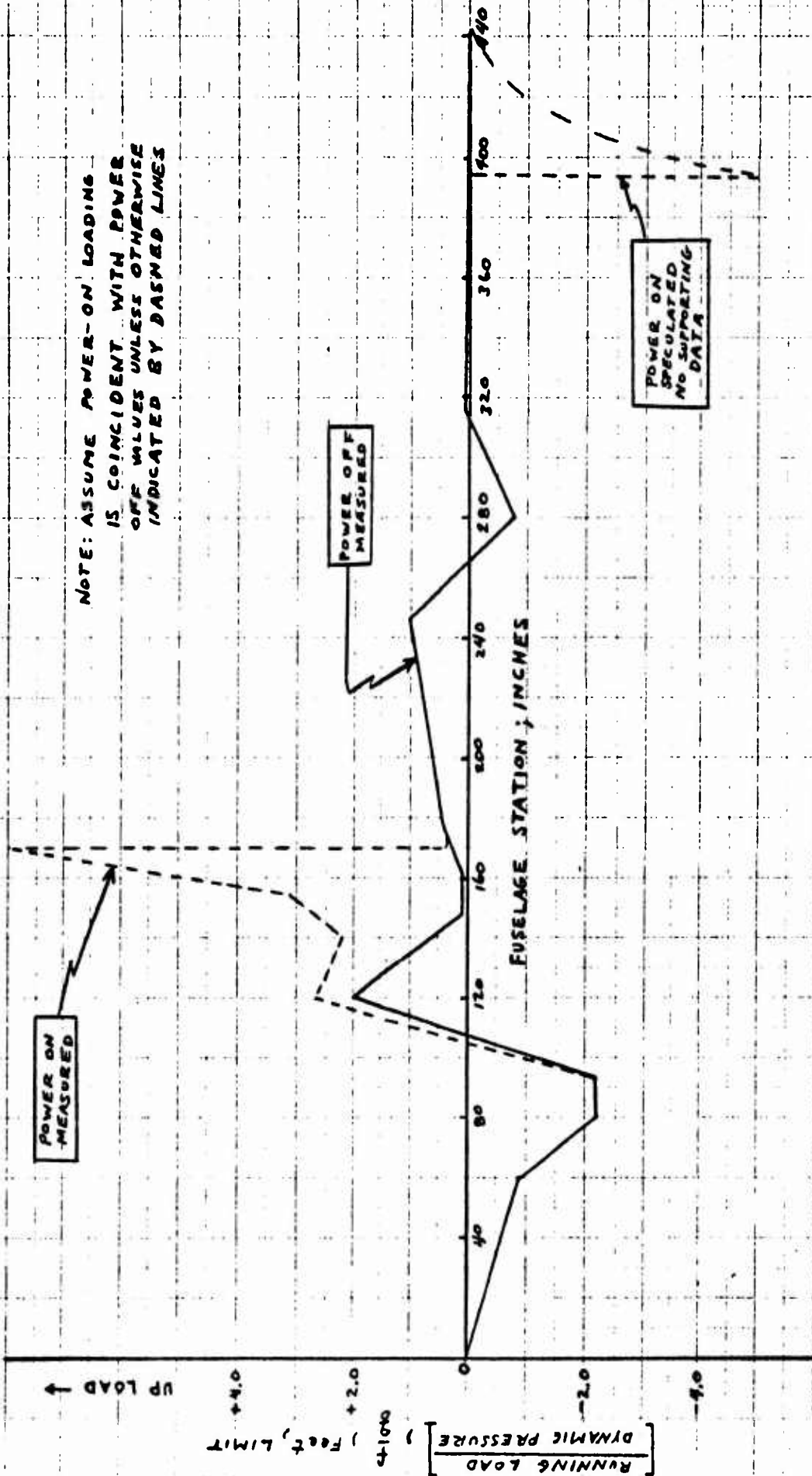

Figure 3.42 Fuselage Vertical Airload Distribution Low Speed, Zero Angle-of-Attack

POWER OFF OR POWER ON
 FUSELAGE IN PRESENCE OF WING
 LOW SPEED, $MN < 0.3$

NOTE: ASSUME POWER ON LOADING
 PER UNIT ANGLE OF ATTACK IS
 COINCIDENT WITH POWER OFF
 LOADING

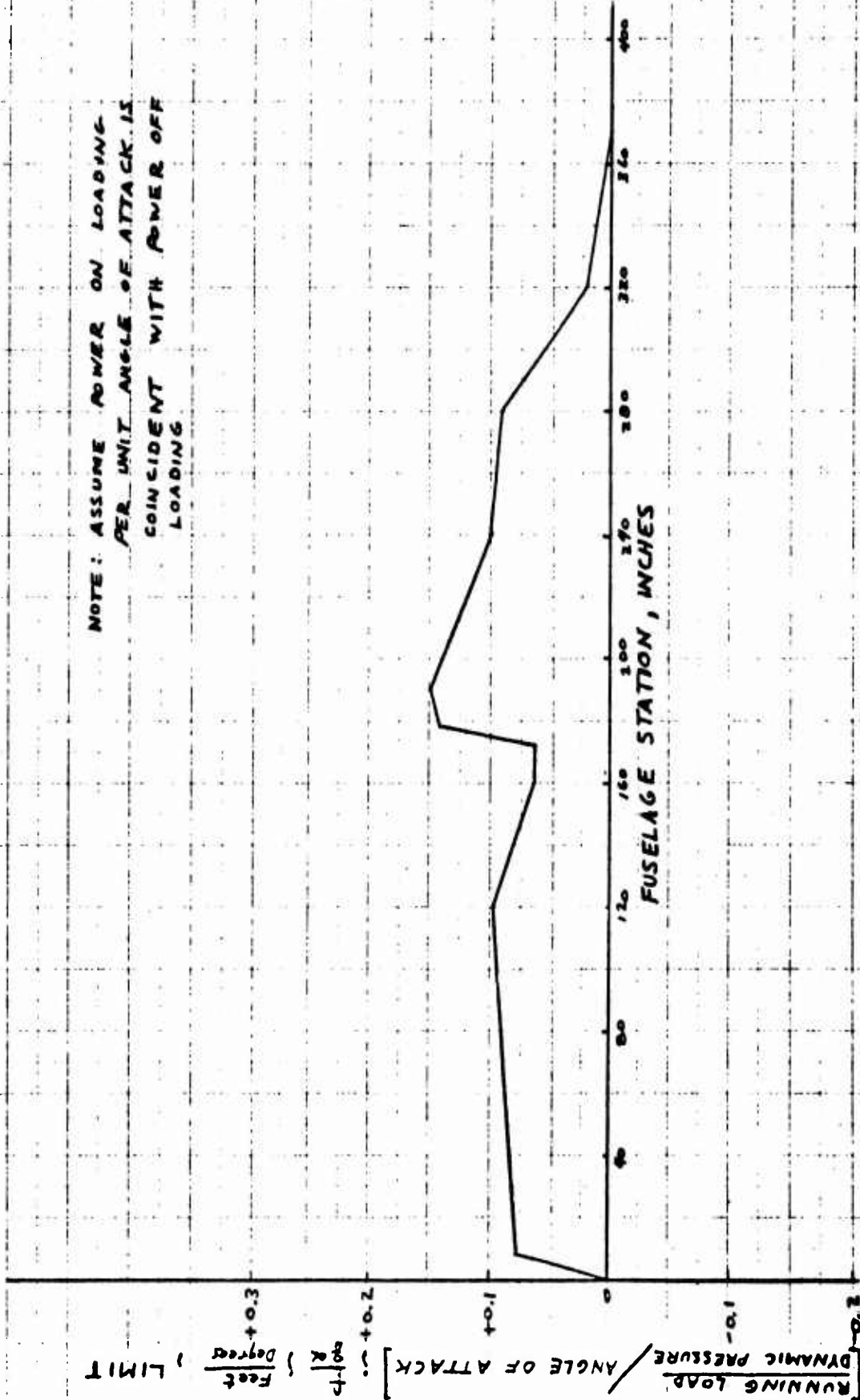

Figure 3.43 Fuselage Vertical Airload Distribution Low Speed, Per Degree Angle-of-Attack

POWER OFF
 FUSELAGE IN PRESENCE OF WING
 MACH NUMBER = 0.8
 $\alpha = 0^\circ$; $\psi = 0^\circ$

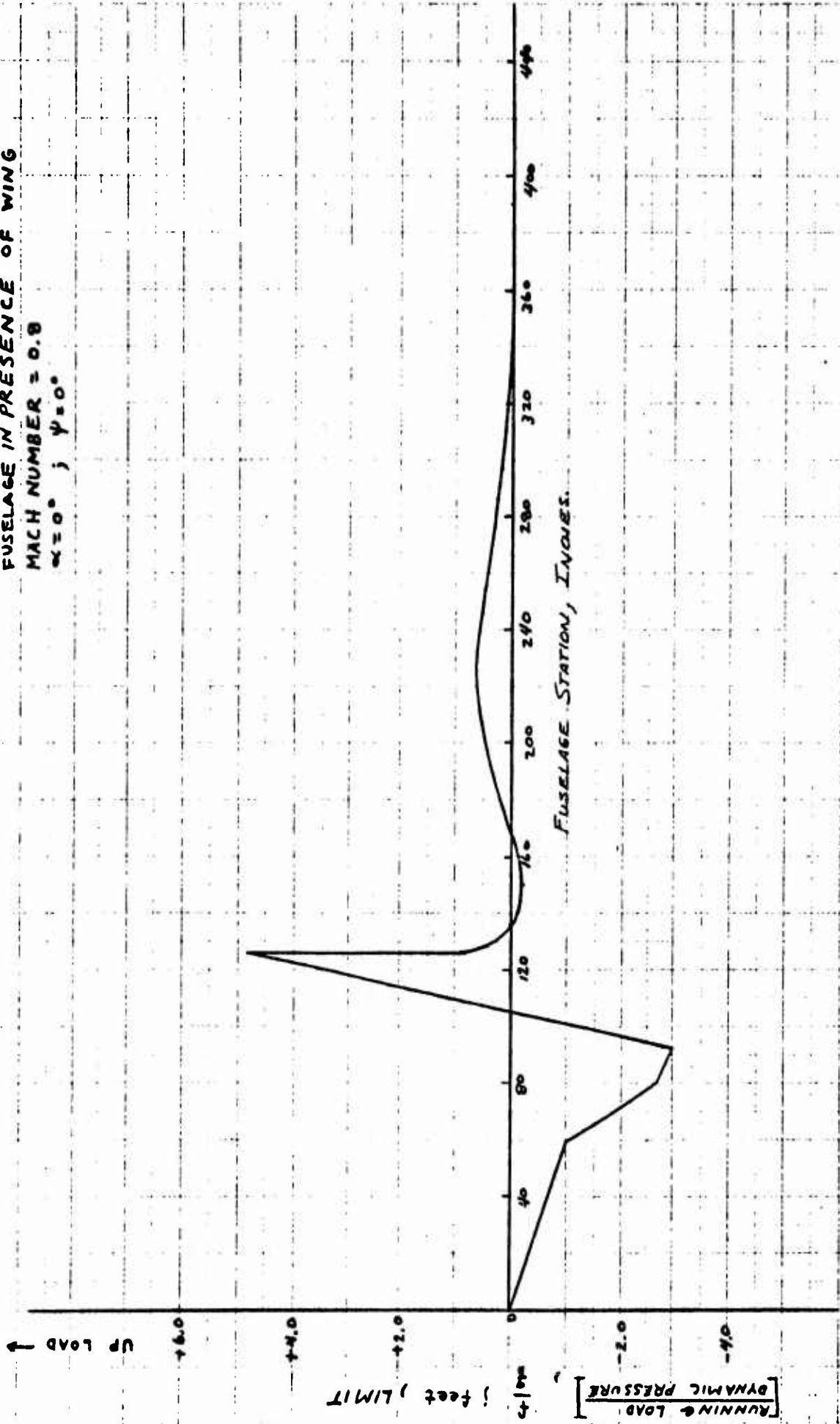

Figure 3.44 Fuselage Vertical Airload Distribution High Speed, Zero Angle-of-Attack

POWER OFF
 FUSELAGE IN PRESENCE OF WING
 MACH NUMBER = 0.8

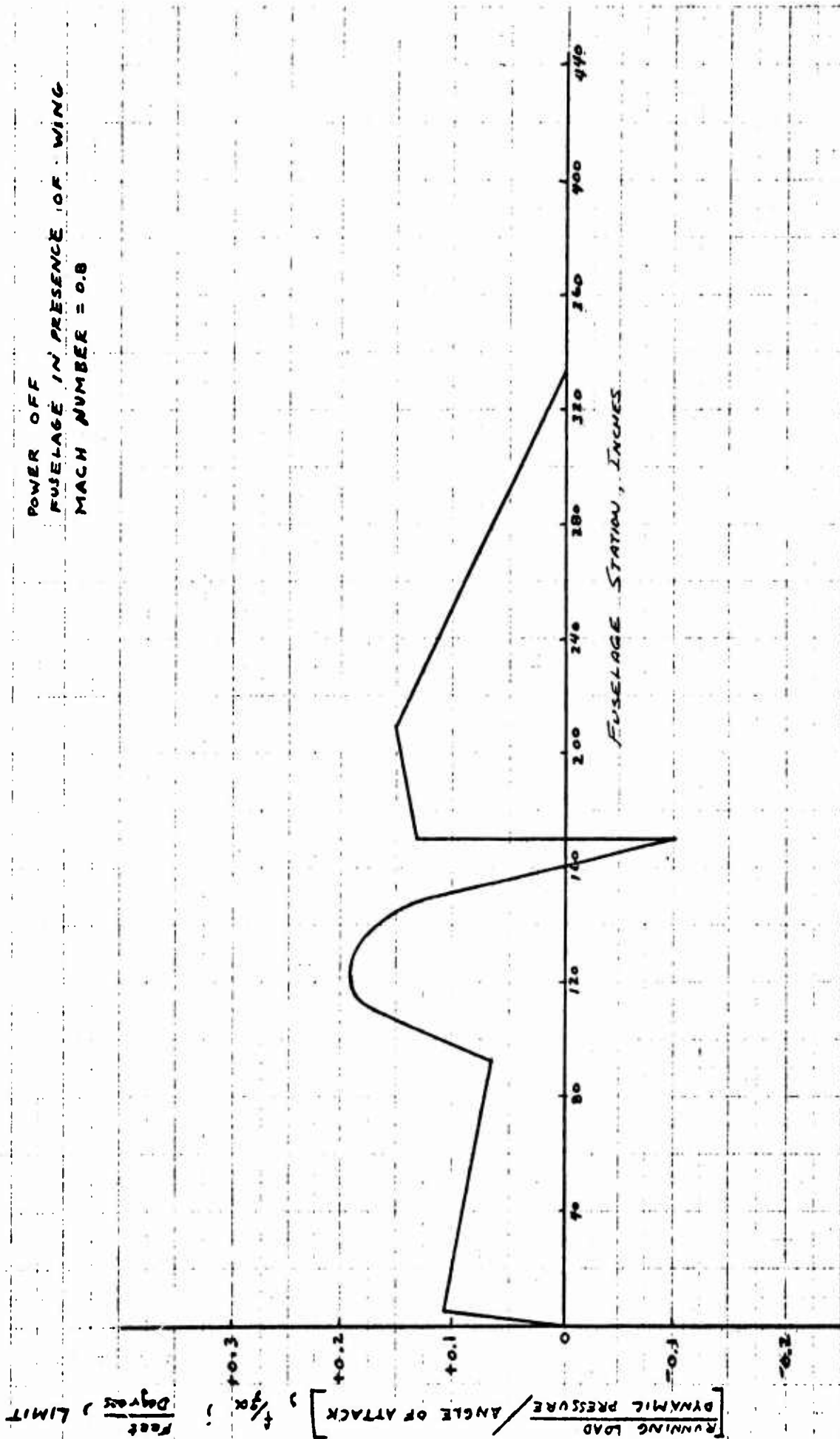

Figure 3.45 Fuselage Vertical Airload Distribution High-Speed, Per Degree Angle-of-Attack

SIDE LOAD COMPONENT
 POWER OFF
 FUSELAGE IN PRESENCE OF WIND
 MACH NO. 20.8

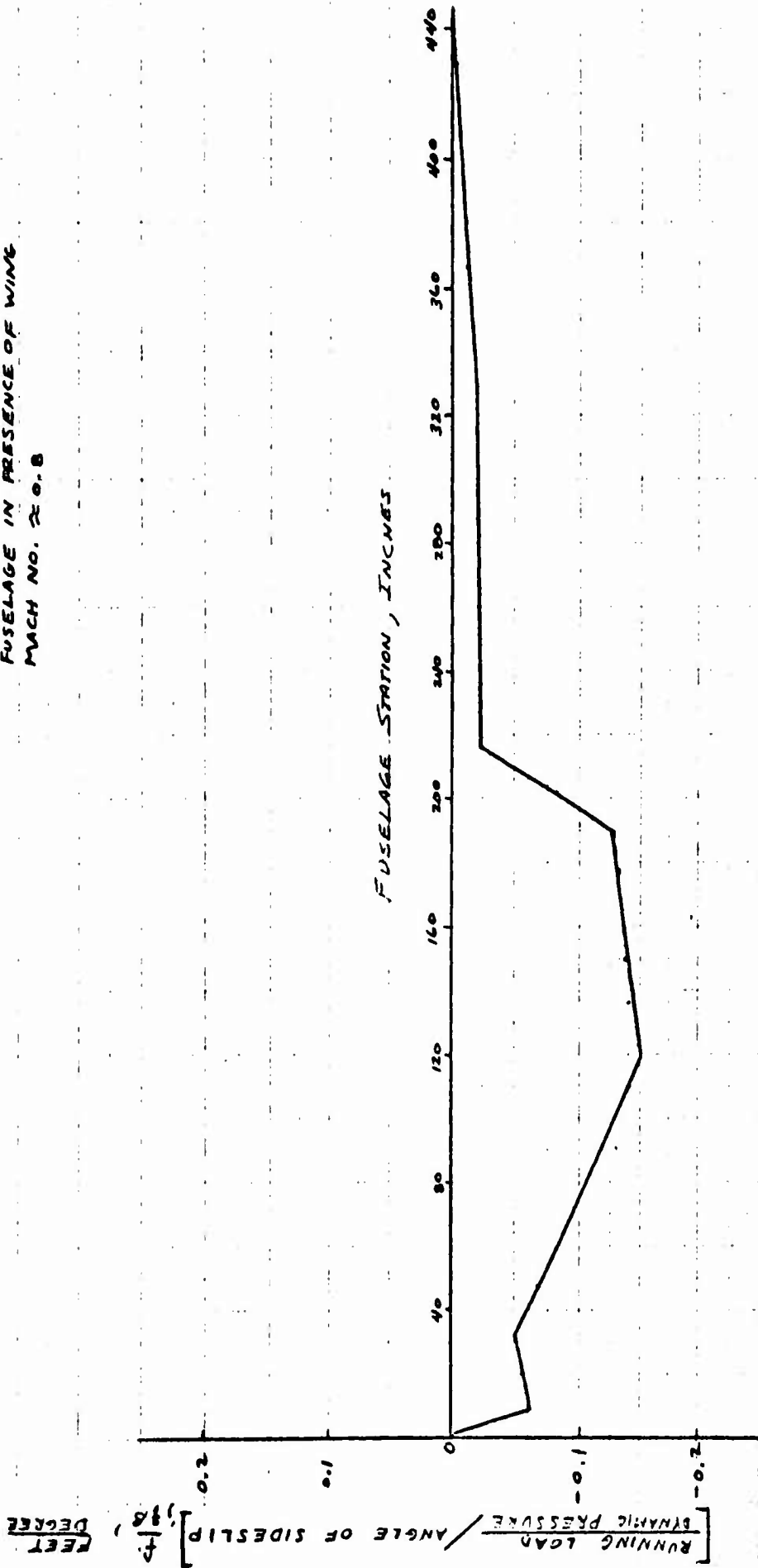

Figure 3.46 Fuselage Side Airload Distribution High Speed, Per Degree Sideslip Angle

3.6.3 Empennage Loading Distribution

3.6.3.1 Inertial Distribution

As an isolated structural component, local inertial contributions were conservatively omitted. Inertial effects on the fuselage, however, were accounted for and only required knowledge of "over-all" inertial properties.

3.6.3.2 Aerodynamic Distribution

The distribution of the aerodynamic contribution was determined through application of the well-known "Lifting Line Theory". This theory, together with a simplified method of solution, may be found in Reference 7. For the present treatment, however, an expanded version was formulated and mechanized for solution with an IBM 704 Digital Computer. The extended method provided greater accuracy (increased number of control points) and solution of all forms of symmetric/anti-symmetric loadings. Since the method only defines the spanwise distribution, local center of pressure was assumed identical, in terms of % chord, to that of an equivalent two-dimensional section with accounting for angle of attack or deflected control surface. With the above information, appropriate integration yielded distributions of shear, bending and torsion.

Distributions and associated characteristics are presented in Figures 3.47 through 3.53.

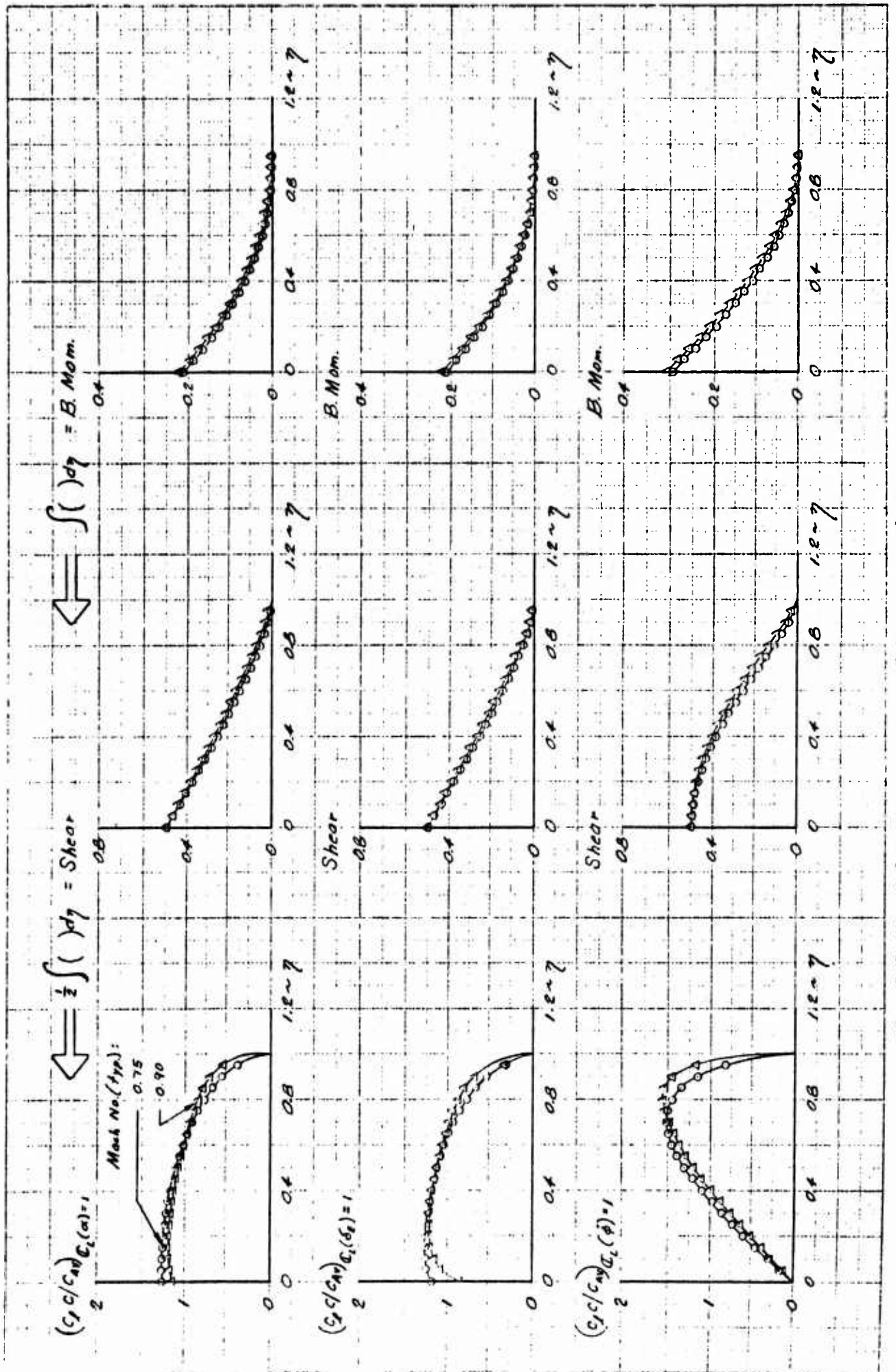

Figure 3.47 Dimensionless Spanwise Loading Distributions Due to α , δ , E & ϕ , Horizontal Tail

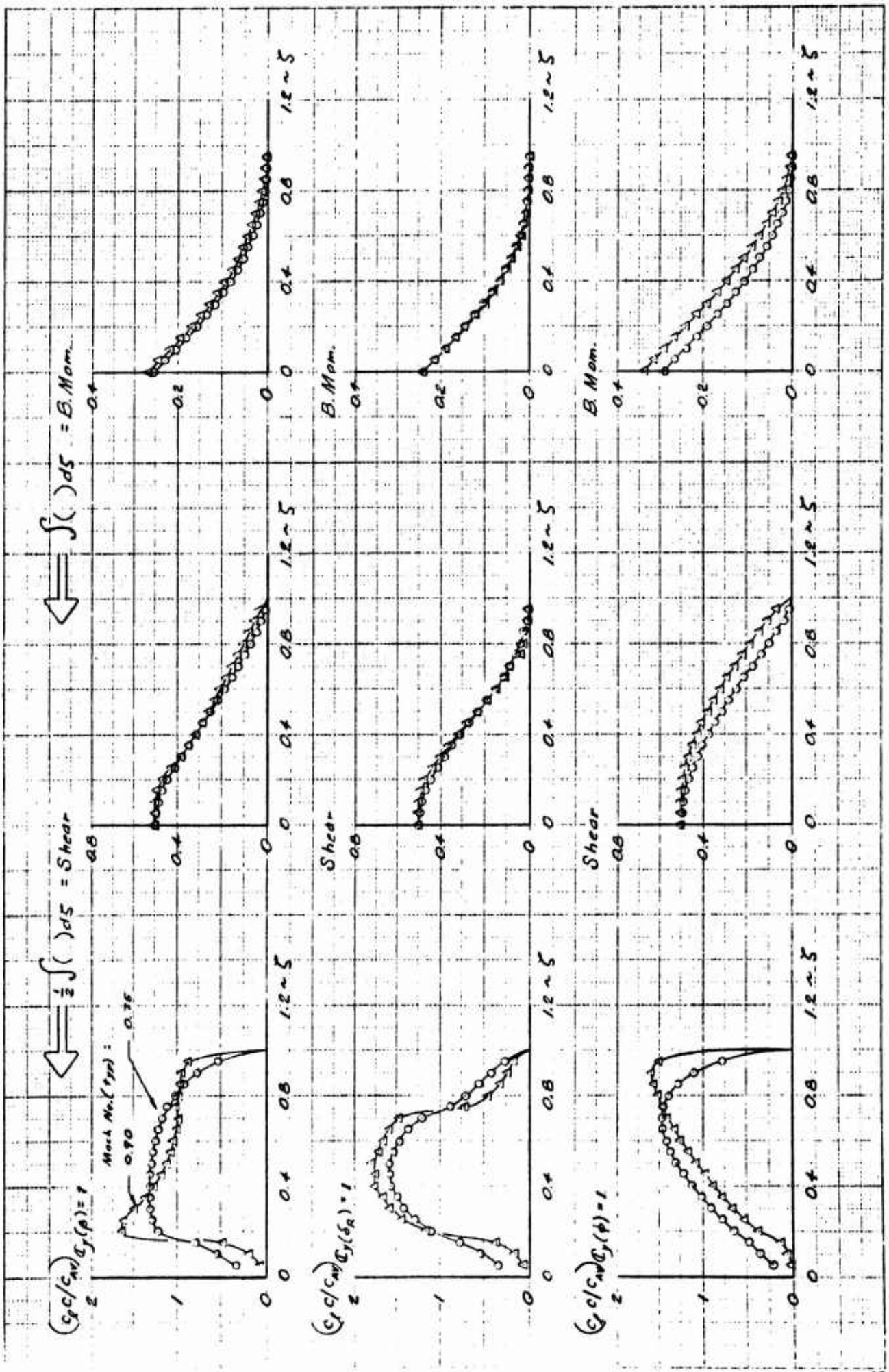

Figure 3.48 Dimensionless Spanwise Loading Distribution Due to β , ϕ R & ψ , Vertical Tail

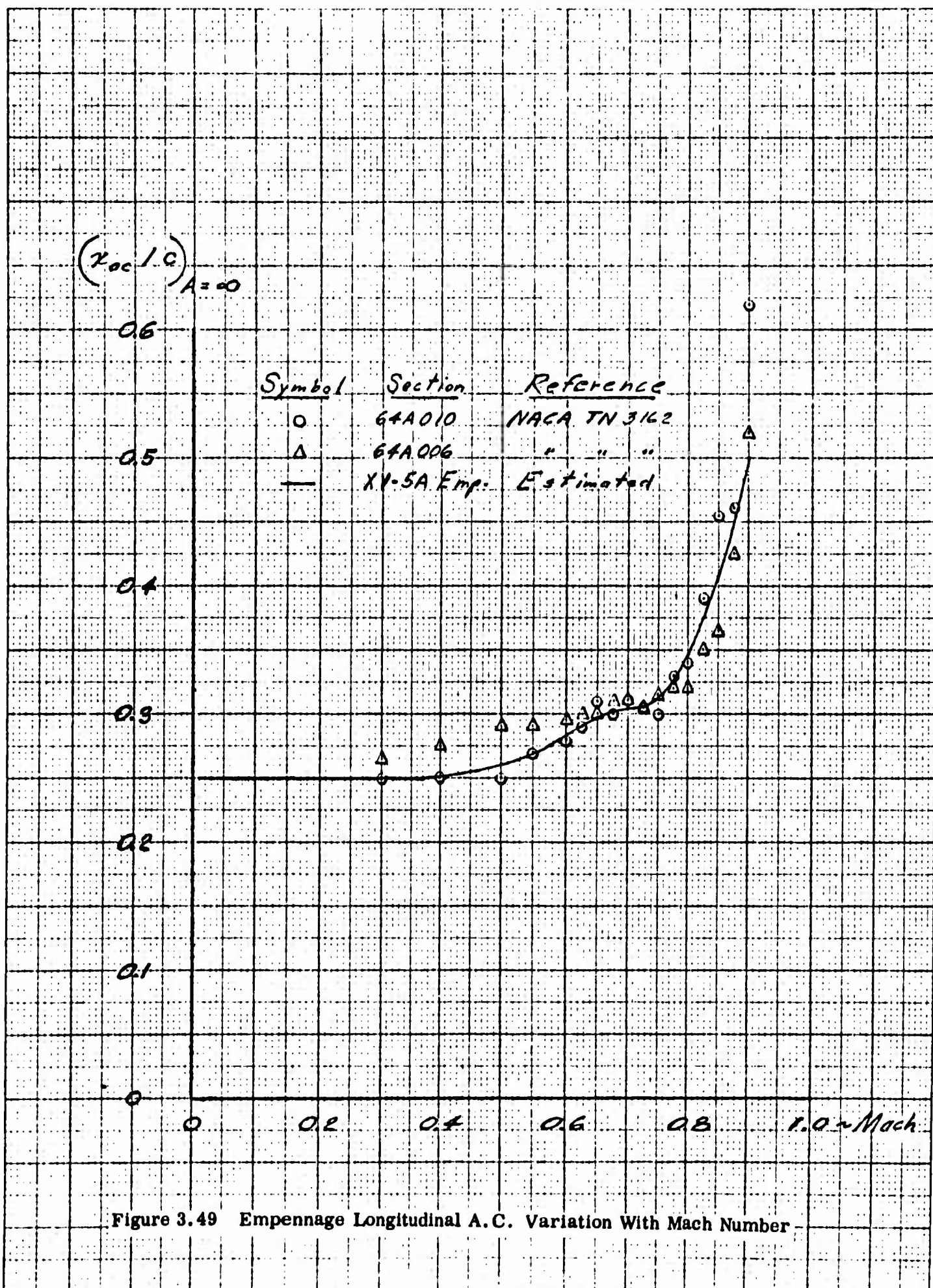

Figure 3.49 Empennage Longitudinal A.C. Variation With Mach Number

Exposed Load, % Total

92

88

84

164

162

160

158

156

SPORWISSE C.P., W.L.

% Exp. Load

Exposed c.p.

Total c.p.

0 0.2 0.4 0.6 0.8 1.0 - Mach

Figure 3.50 Vertical Tail Loading Characteristics Due to δ_R - Type of Loading

Exposed Load, % Total

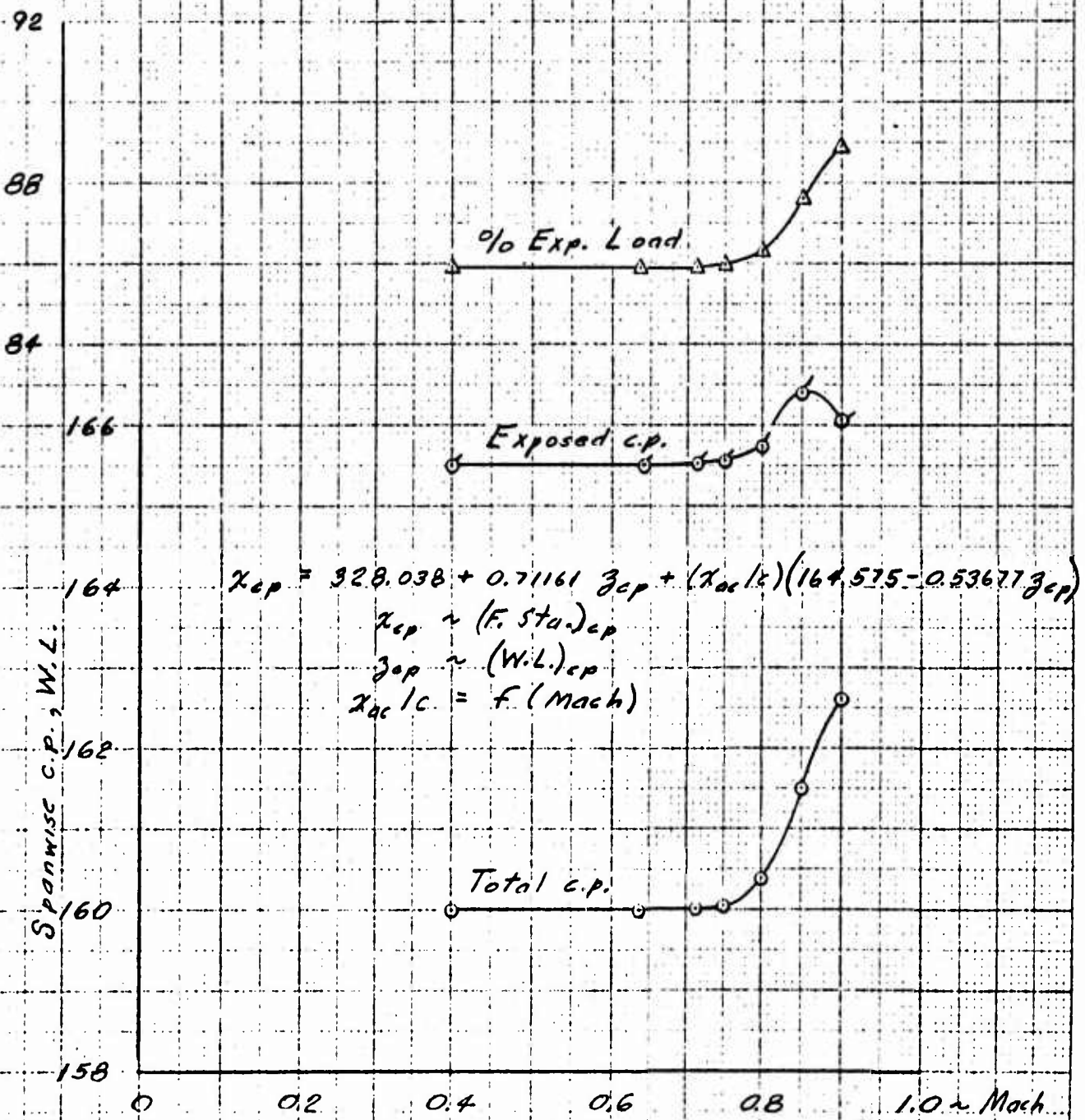

Figure 3.51 Vertical Tail Loading Characteristics Due to β - Type of Loading

Exposed Load, % Total

100

$$x_{cp} = 328.038 + 0.71161 z_{cp} + (x_{ac/c})(164.575 - 0.53677 z_{cp})$$

$x_{cp} \sim (F. Sta.)_{cp}$

$z_{cp} \sim (W.L.)_{cp}$

$x_{ac/c} = f(\text{Mach})$

96

92

% Exp. Load

88

172

170

Exposed c.p.

168

166

Total c.p.

Spanwise c.p., W.L.

0

0.2

0.4

0.6

0.8

1.0 Mach

Figure 3.52 Vertical Tail Loading Characteristics Due to ϕ - Type of Loading

Spanwise c.p. (ϕ), B.L.

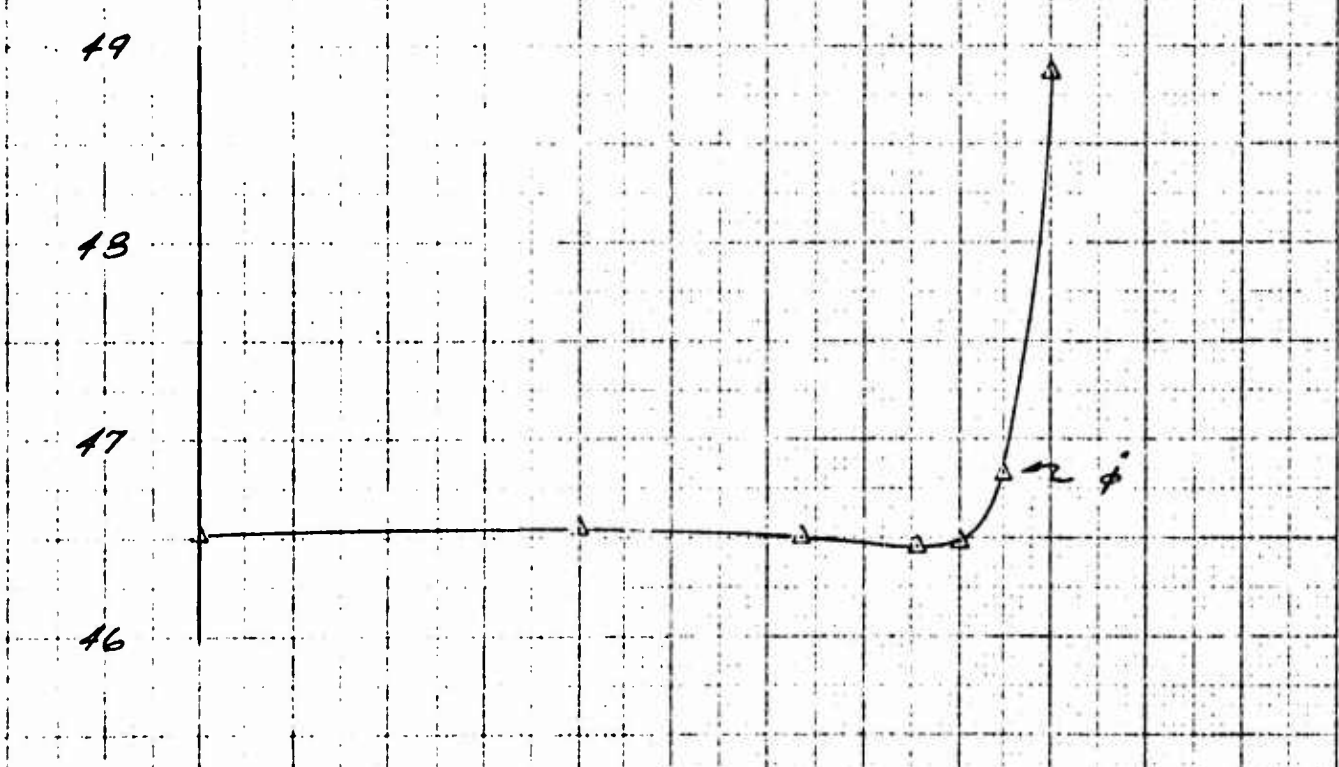

Spanwise c.p. (α, δ_E), B.L.

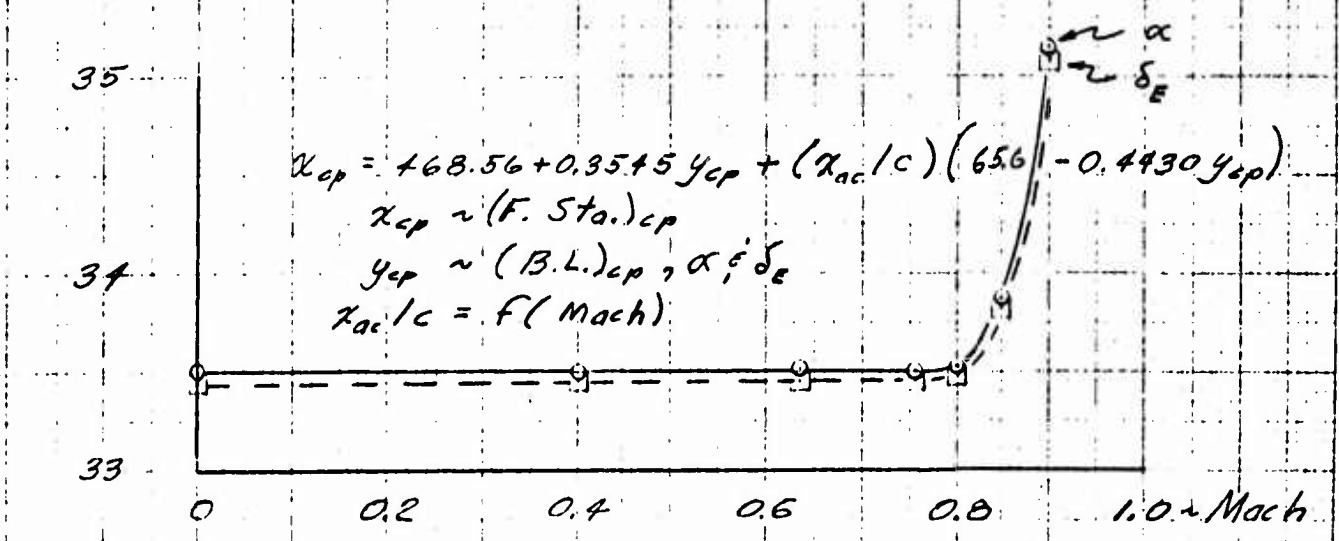
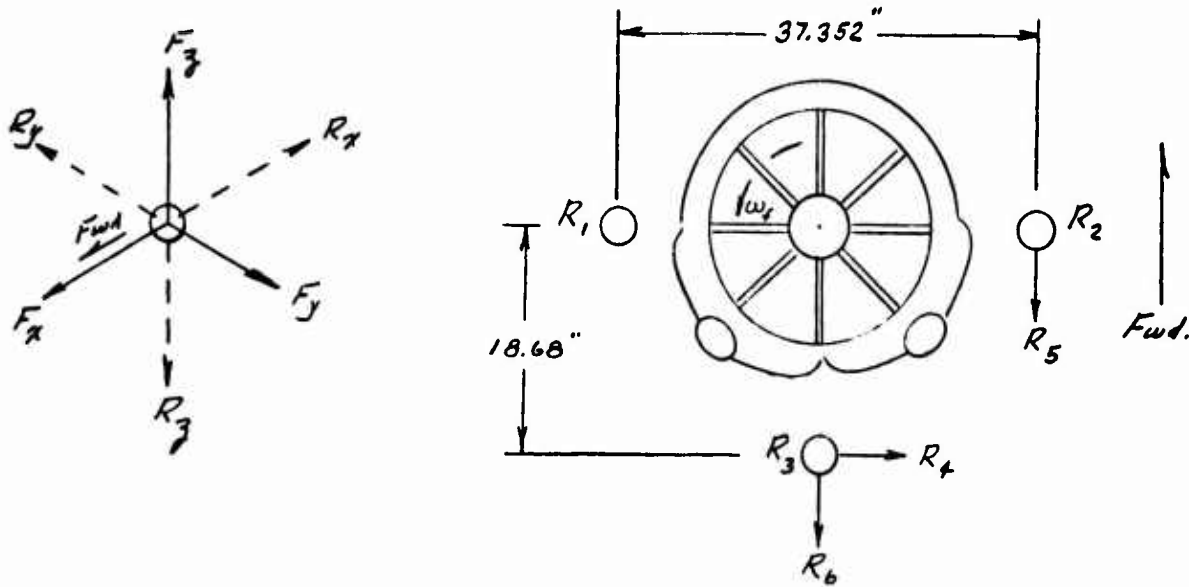

Figure 3.53 Horizontal Tail Loading Characteristics Due to α δ_E & ϕ - Types of Loading

3.7 PROPULSION SYSTEM

Loads relevant to the propulsion system were determined by multiplication of "unit" mount reactions - presented in Tables 3.5 through 3.8 - by specific values of, primarily, inertia parameters derived from flight maneuver investigations and/or values dictated by the design criteria. The data which these tables contain were derived from information supplied by the General Electric Company. Although these data were based on motion with respect to the particular propulsion unit, only axes transformation was considered in the case of the pitch fan and additional incremental values are, therefore, included in that table.

Particular solutions are not shown in this report, but are presented in the appropriate stress report, when and where applicable.



Unit Input	R_1	R_2	R_3	R_4	R_5	R_6
Lift = 1.0 lb.	0.324	0.324	0.090			
$\eta_x = 1$	-4.72	-4.72	9.84			-105
$\eta_y = 1$	-4.72	4.72		-105	-92.9	92.9
$\eta_z = 1$	-46.1	-46.1	-12.8			
$\omega_x = 1 \text{ r/s}$	-204	-204	408			
$\omega_y = 1 \text{ r/s}$	-204	204				
Incr. for A/C c.g. :						
$\omega_x^2 = 1 (\text{r/s})^2$	-1.4	-1.4	-0.4			
$\omega_y^2 = 1 (\text{r/s})^2$	2.4	2.4	-4.8			50.9
$\omega_z^2 = 1 (\text{r/s})^2$	2.4	2.4	-4.8			50.9
$\dot{\omega}_x = 1 \text{ r/s}^2$	-0.2	0.2		-3.2	-2.8	2.8
$\dot{\omega}_y = 1 \text{ r/s}^2$	22.3	22.3	6.2			
$\dot{\omega}_z = 1 \text{ r/s}^2$	-2.4	2.4		-50.9	-44.7	44.7

- Note: 1) Fan lift assumes 26.3% on fuse. & bellmouth surfaces
 2) Assumed fan RPM = 4684 (max. short time o.s. limit)
 3) Assumed A/C c.g. : F. Sta. 246, WL 112

Table 3.5 Unit Pitch Fan Mount Reactions

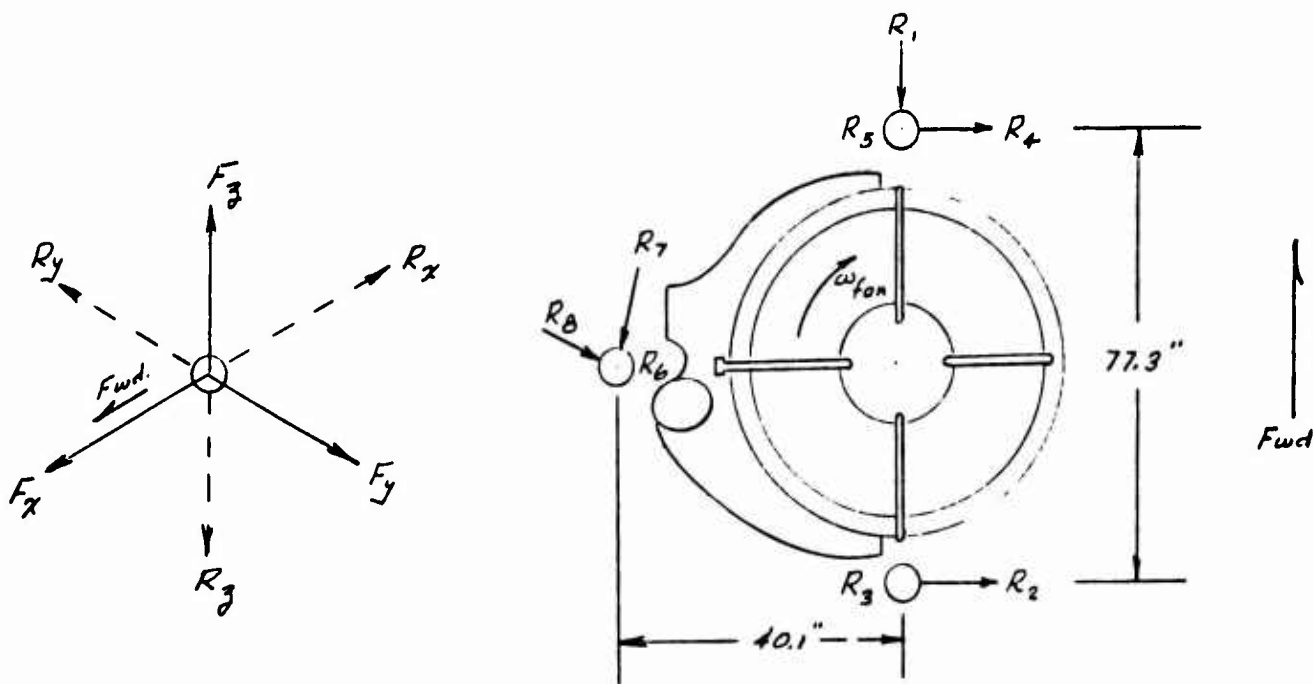

Unit Input	R_1	R_2	R_3	R_4	R_5	R_6	R_7	R_8
Thrust ($\beta = 0$)			2815		2815	330		
Thrust ($\beta = 40^\circ$)	3670	166	1318	-166	2322	340		
Scroll Piston Forces								
Left Engine Only	-448	-29		-477		155	2420	-3490
Right Engine Only	30	-260	-85	-290	485	-2879	-1810	
Fan Torque								
Left Engine Only	1009	883		-167		200	-1030	
Right Engine Only	1009	123		927		200	-1030	
$\pi_z = 1$			-383		-383	-93		
$\pi_y = 1$		429	-37	429	-37	74		
$\pi_x = 1$	-770		37		-37	20	-91	
Cross Flow (130 Kts.)	-308		257		-257	514		
$\omega_y = 1 \text{ r/s}$			1195		1195	-2390		
$\omega_x = 1 \text{ r/s}$			-1240		1240			

Note: 1) Data based on G.E. corres. dtd. 19 Nov. 62
 2) Thrust reactions are for Std. S.L. conditions

Table 3.6 Unit Wing Fan (Starboard) Mount Reactions

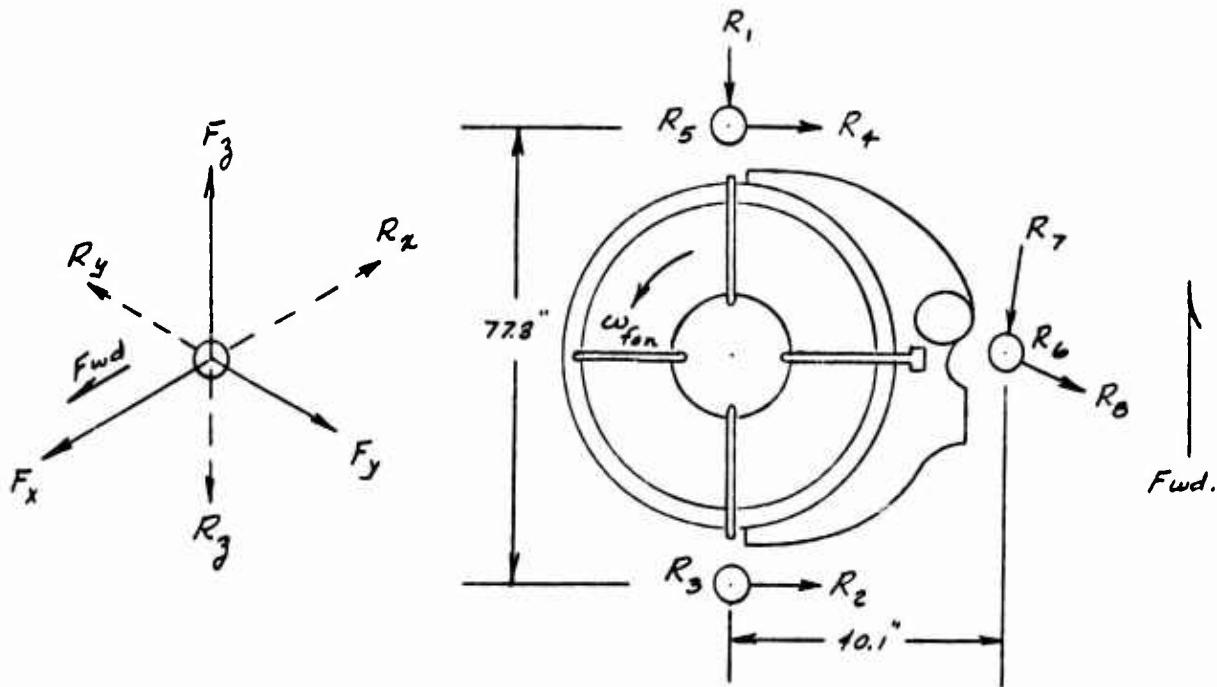

Unit Input	R_1	R_2	R_3	R_4	R_5	R_6	R_7	R_8
Thrust ($\beta = 0$)			2815		2815	330		
Thrust ($\beta = 40^\circ$)	3670	-166	1918	166	2322	310		
Scroll Piston Forces								
Left Engine Only	-30	230	485	260	-85	-2879	1810	
Right Engine Only	448	477		29		155	-2420	3430
Fan Torque								
Left Engine Only	1009	-927		123		-200	-1080	
Right Engine Only	1009	-167		883		-200	-1030	
$n_z = 1$			-383		-383	-93		
$n_y = 1$		-429	-37	-429	-37	74		
$n_x = 1$	-770		37		-37	-20	-91	
Cross Flow (130 kts.)	-308		257		257	-514		
$\omega_y = 1 \text{ r/s}$			-1195		-1195	2390		
$\omega_x = 1 \text{ r/s}$			1240		-1240			

Note: 1) Data based on G.E. corres. dtd. 19 Nov. '62
 2) Thrust reactions are for Std. S.L. conditions

Table 3.7 Unit Wing Fan (Port) Mount Reactions

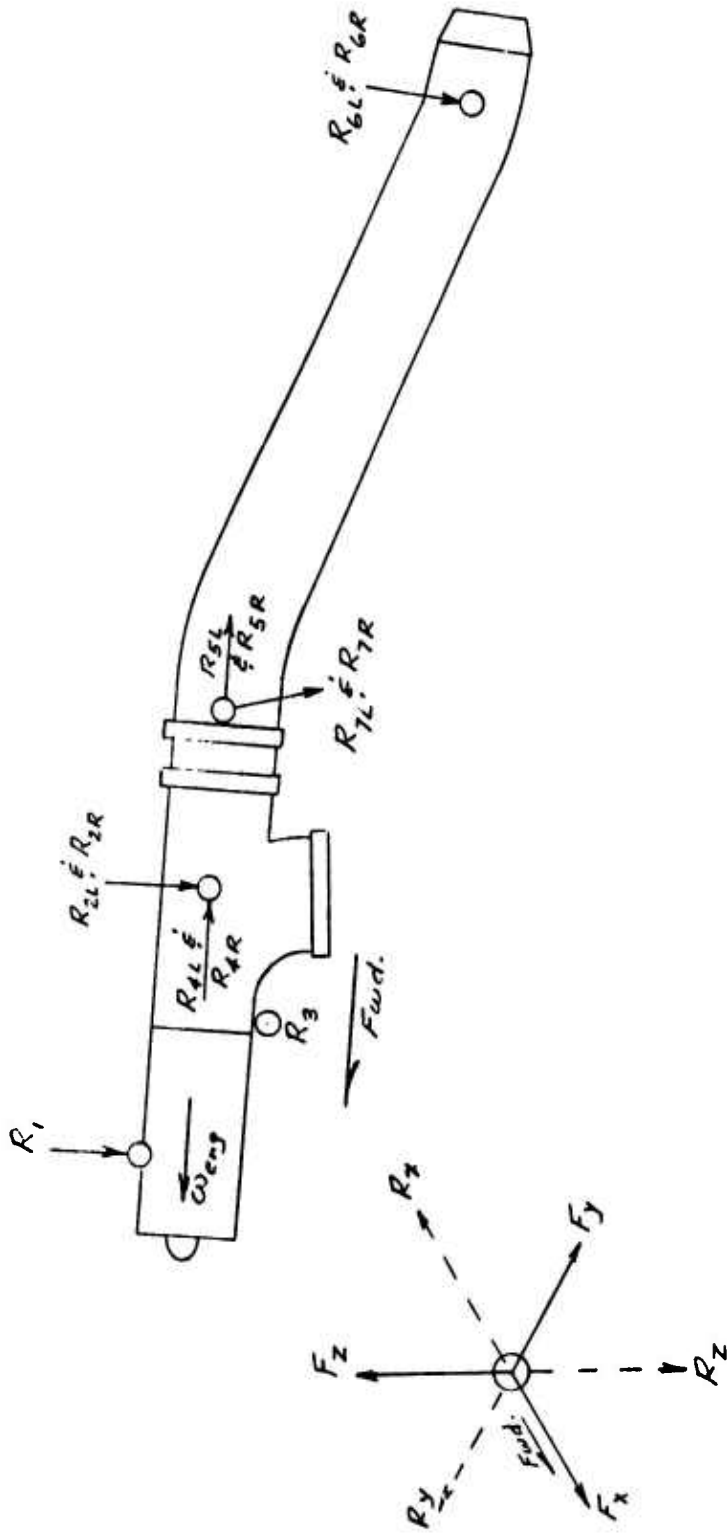

Unit Input	R_1	R_{2R}	R_{2L}	R_3	R_{4R}	R_{4L}	R_{5R}	R_{5L}	R_{6R}	R_{6L}	R_{7R}	R_{7L}
$\eta_z = 1$	-357	-56	-56									
$\eta_y = 1$		-193	+193	-468	+262	-262						
$\eta_x = 1$					-234	-234						
$\omega_y = 1 \text{ r/s}$					560	-560						
$\omega_z = 1 \text{ r/s}$	276	-198	-198									
Axial Thrust (2)					2000	2000	1695	1695	-1300	-1300	1560	1560
Diverter Thrust (3)	161	3080	3080		277	277						

Note: 1) Data based on G.E. Corres. dtd. 20 Nov. '62

2) Tied bellows, Std. S.L. conditions, $V = 530 \text{ Kts.}$

3) Free bellows, Std. S.L. conditions, $V = 130 \text{ Kts.}$, Gas Load = 6350 lb.

Table 3.8 Unit Engine (J85-5) Mount Reactions

3.8 MISCELLANEOUS ITEMS

3.8.1 Parachute Applications

Two (2) different parachutes are employed by the XV-5A. The larger of the two serves for aerodynamic braking during landing and the other has the dual usage of high-speed decelerations or spin-recovery.

Drag forces were computed on the basis of the following fundamental expression:

$$F = C_{D_o} S_o \bar{q} X \quad (1)$$

where

X = opening shock factor

Pertinent characteristics of the parachutes which were used in the analysis follow:

Landing Chute

1. Type: Ring Slot
2. D_o : 12.75 ft.
3. C_{D_o} : 0.55
4. X: 1.05
5. Max. deployment speed: 168 KEAS

High Speed Chute

1. Type: Ribless Guide Surface
2. Ref. dia.: 6 ft.
3. $C_{D_o} S_o$: 16.688 ft.²
4. X: 1.17

5. Max. deployment speed:

- a) high-speed deceleration ... 500 KEAS
- b) spin recovery 125 KEAS

3.8.2 Landing Gear

Drag loads developed by the extended nose and main landing gear during a landing approach condition were based on a maximum speed of 180 KEAS. Drag was assessed for each member (struts, braces, etc.) on the basis of frontal area and drag coefficients obtained from Reference 9. The incremental forces and moments were then summed up to yield net load and center of pressure. In general, a wheel drag coefficient of 0.35 and member drag coefficient of 0.4 were used.

The drag at intermediate gear positions were assumed to vary as a sine function of the extended angle.

3.8.3 Thrust Spoiler

Thrust spoiler loads were assumed to result solely from the impingement of exhaust gases acting normal to the apparent surface of the deflected (75°) plane in diverting the thrust through an effective 60-degree angle. Gross thrust was based on an engine RPM of 98.6% ± 0.5%, hot day conditions and 2500 ft. altitude.

3.8.4 Nose-Fan Thrust Modulator

Design loads for fan mode flight were determined from scale-model tests conducted by the General Electric Company which produced the characteristics shown in Figure 3.54.

High-speed loading was determined from wind-tunnel surface pressure data.

3.8.5 Wing-Fan Closure Doors

For the fan-supported flight mode, door loads were evaluated with consideration of various flight conditions inclusive of a 110 knot conversion speed, corresponding angles of attack, louver vector/stagger angles, and exposure to lateral gusts of 40 ft/sec.

Note: X376 Scale Factors...

Bleed Setting	SLS Cold Day (0°F)	ANA Hot Day
1300#	26.4	18.1
1500#	30.4	21.1

Opening Moment, per door, in-lbs

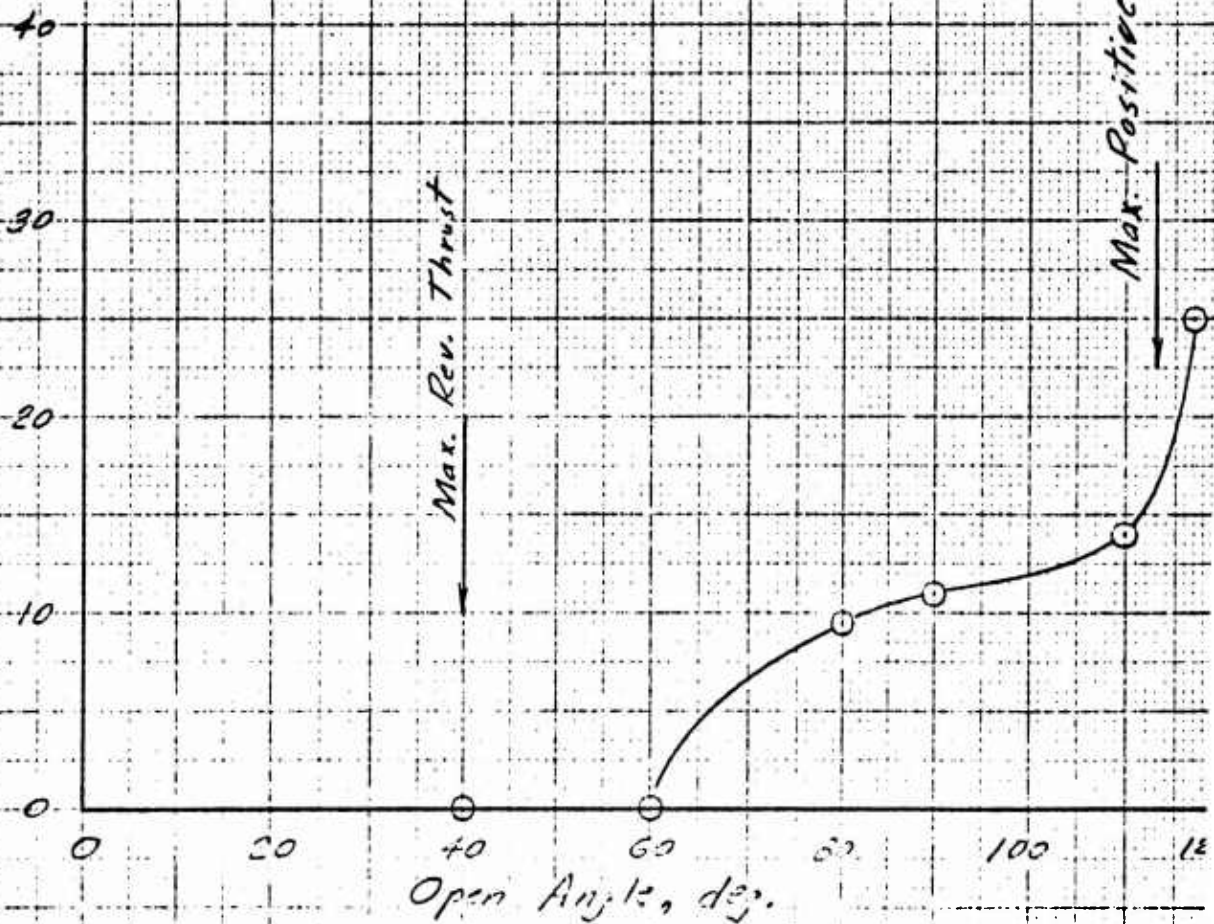

Figure 3.54 Thrust Modulator Door Hinge Moments, 26" - Scale Model

For the conventional flight mode, pitching maneuvers were evaluated and a critical speed/angle-of-attack combination determined which produced the most critical pressure loading on the door. Originally, the distribution of internal pressure on the door was assumed identical to the pressure on the lower surface of the wing and later modified to account for louver leakage.

Surface pressures were obtained from the 1/8-scale wind-tunnel model tests. However, two other similar tests served to define force and moment characteristics of the door (fully opened) for the fan-supported flight mode. Ames wind-tunnel tests of a full-scale model provided the required data for unyawed flight. The affects of yaw were determined from hinge moment measurements on a 1/6-scale model (complete airplane) having a "representative" door geometry. Force and moment characteristics of the Ames tests are summarized in Figures 3.55 through 3.58.

Note: Left wing panel
 $\alpha = \beta = 0$
 100% RPM

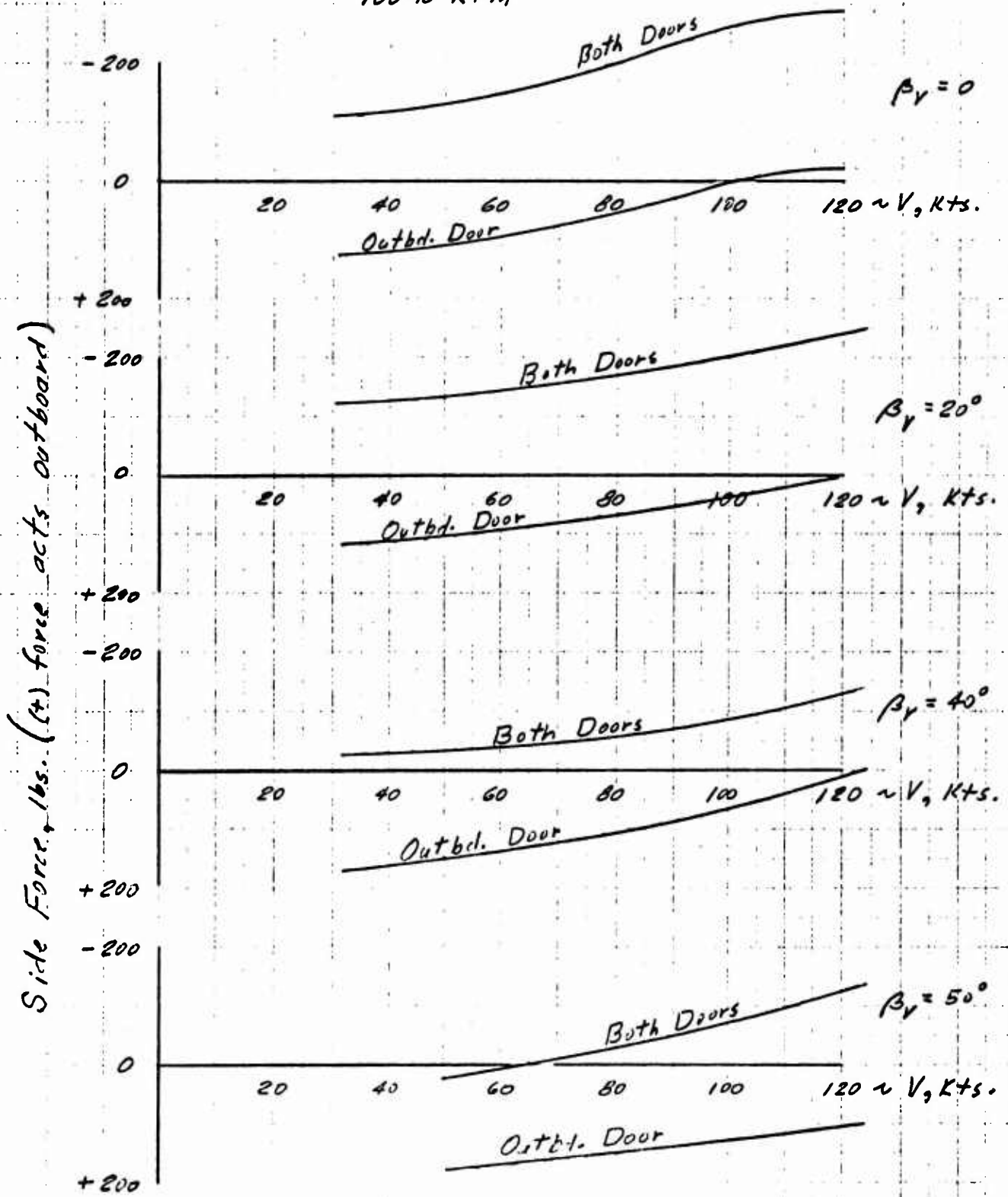

Figure 3.55 Wing Fan Door Side Force, Ames Tests

Door Closing Moments, in-lbs. (+) mom. tends to, respects, open/close outfl./inbl. door

Notes: Left wing panel
 $\alpha = \beta = 0$
100% RPM

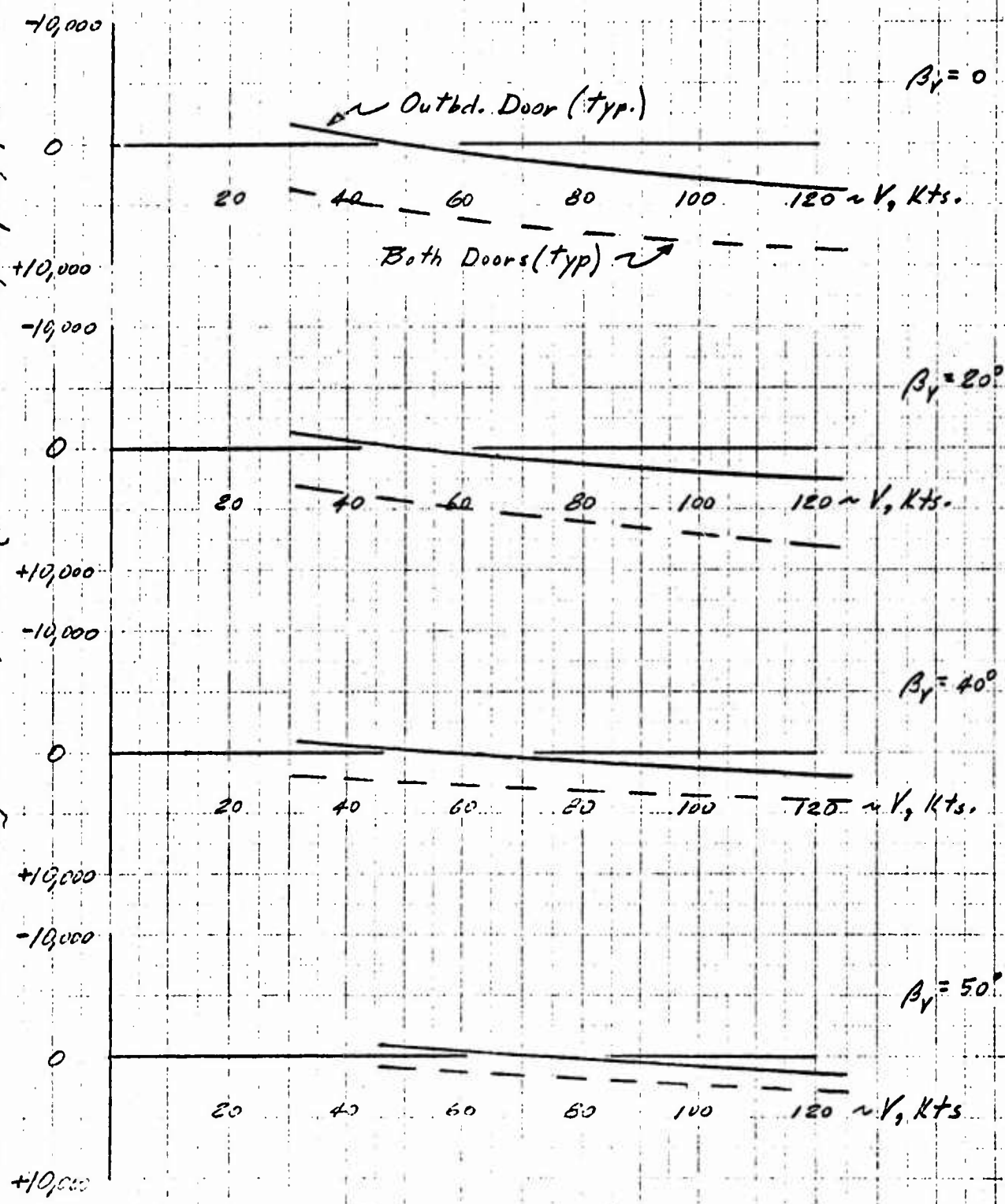

Figure 3.56 Wing Fan Door Closure Moments, Ames Tests

Note: Left wing panel
 $\alpha = \beta = 0$
 100% RPM

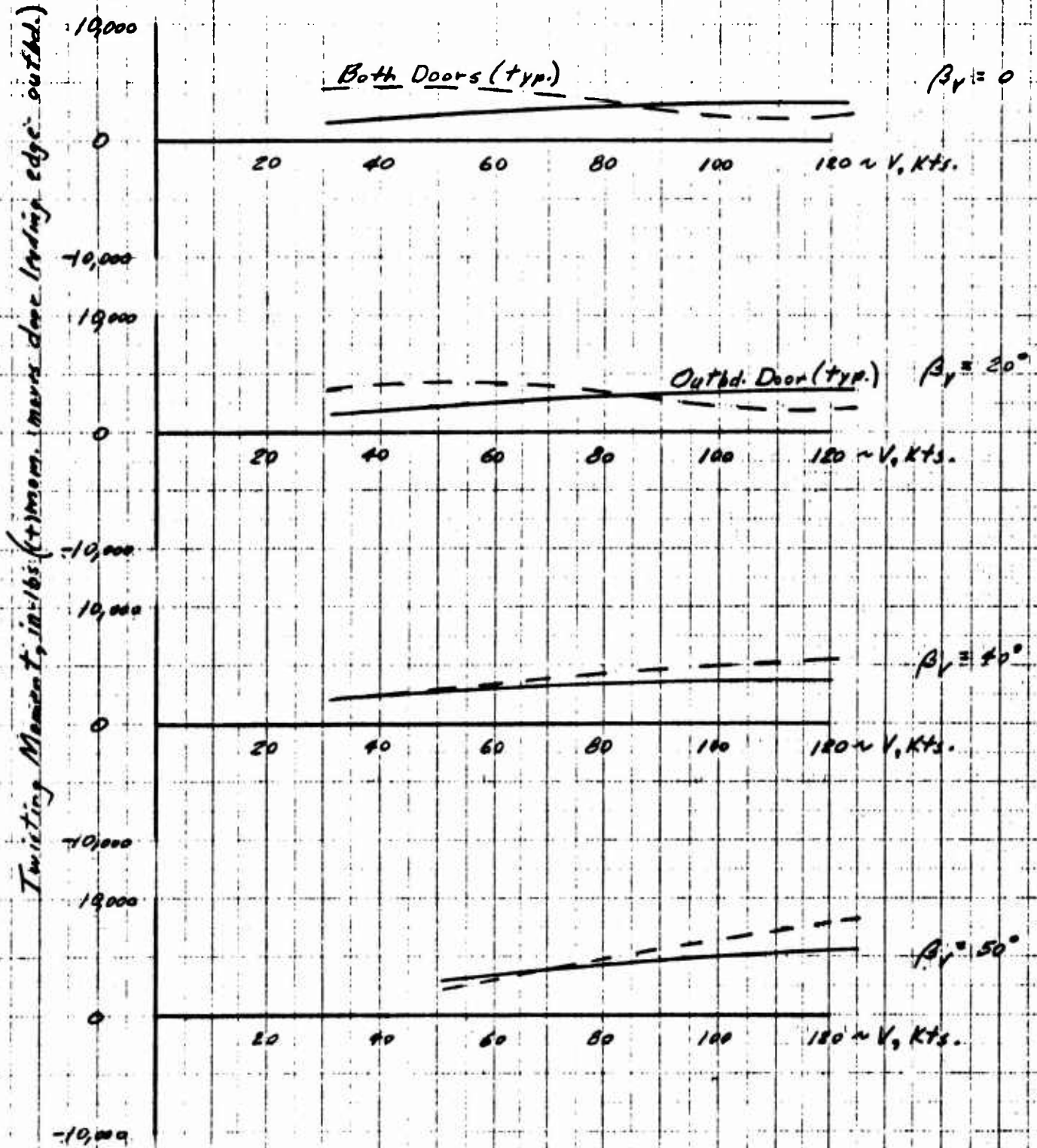

Figure 3.57 Wing Fan Door Twisting Moments, Ames Tests

Note: Left wing panel
 $\beta_V = 35^\circ, \beta = 0$
 $V = 125$ Kts.

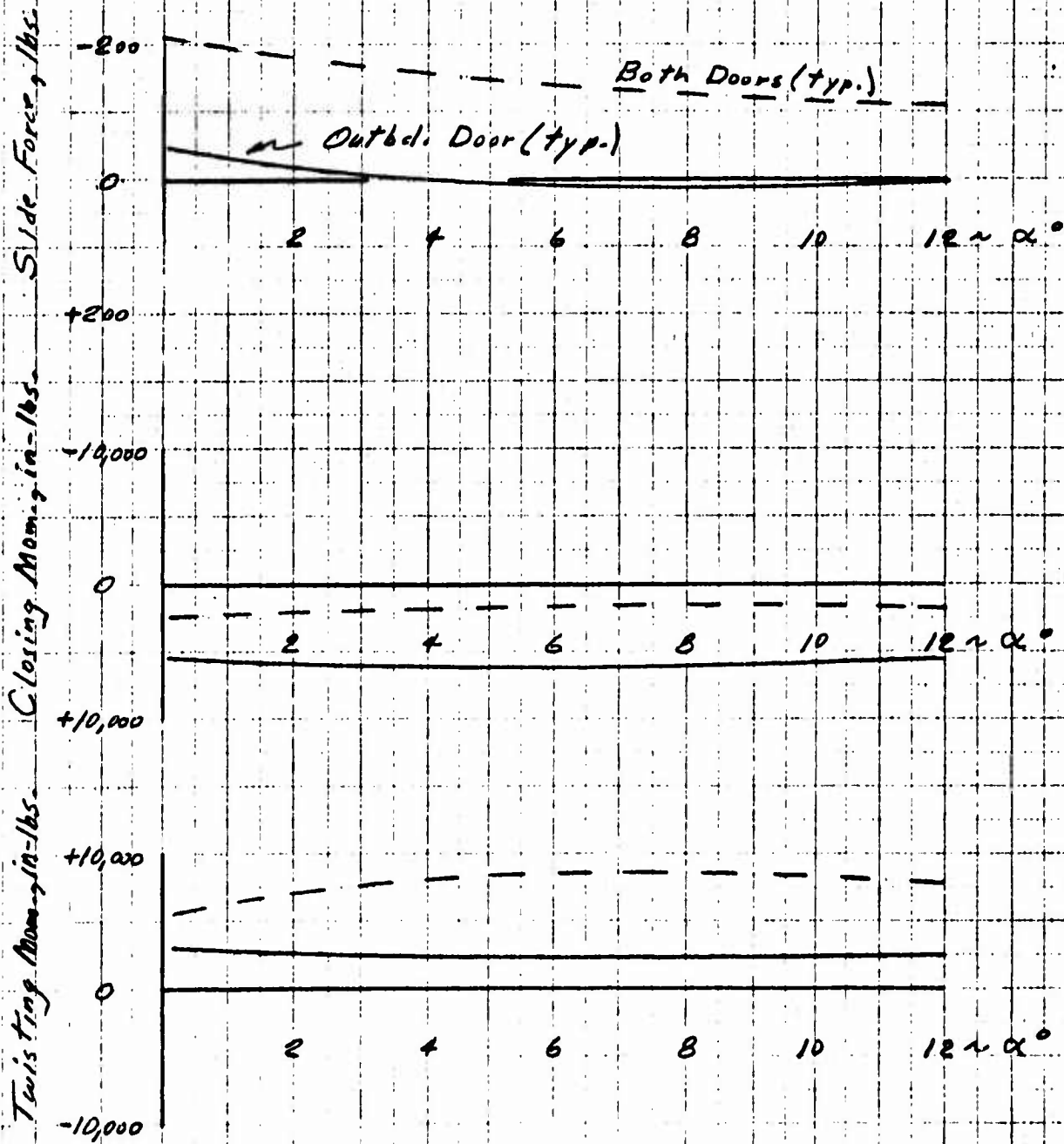

Figure 3.58 Wing Fan Door Forces & Moments Due to Angle-of-Attack, Ames Tests

4.0 RESULTS

4.1 MANEUVERING FLIGHT

4.1.1 Pitching Maneuvers

A comprehensive study of the loads encountered by the airplane during symmetrical flight was made which encompassed all primary points on the V-n diagram, and the associated parameters of angular rate, with and without angular acceleration. In addition, parameters of Mach number, altitude, engine thrust and c. g. location were evaluated.

In the analysis of a flight condition, the airplane is considered to be initially in level unaccelerated flight at the velocity and altitude appropriate to the maneuver. Airplane longitudinal balance is accomplished by means of horizontal-tail incidence. From this initial condition, the airplane is then balanced for the desired maneuver by deflecting the elevator while maintaining constant horizontal-tail incidence.

Shown in Table 4.1 is a partial listing of the conditions investigated. Those conditions which require an elevator deflection (δe) larger than the available limits ($\pm 25^\circ$) are shown with a slash through the listed value of δe . The power-on conditions were determined using the engine performance characteristics shown in Figure 4.1.

All of the listed conditions assume a rigid airframe. The effects of an elastic wing upon loads were investigated for flight conditions F-1 through F-8 and F-21 through F-24. No appreciable change in loads resulted from the investigation. In most cases, the loads on the airplane components were slightly lower.

The effects of altitude upon the airplane loading are shown in Figure 4.2. In all cases investigated, the magnitude of the structural loading decreased with an increase in altitude.

The airplane component loads which result from selected flight conditions are shown in Figures 4.3 and 4.4 as a function of Mach number. In Figure 4.3 the loads on the wing alone and wing-body combination are presented for the symmetrical flight maneuvers which produce the critical loading. Figure 4.4 shows similar curves for the critical horizontal-tail loading conditions.

XV-5A SYMMETRICAL FLIGHT LOADINGS

POWER-OFF FLAPS UP

MINIMUM ALTITUDE COMPENSURATE WITH GIVEN MACH NO. AND SPEED-ALTITUDE LIMITS

F NUMBER	POINT ON Y-R DIAG.	MACH NO.	CG STA.	Mz	$\dot{\theta}$ R/SEC	$\dot{\theta}$ DEG	δe DEG.	H. TAIL LIFT DUE TO α	H. TAIL LIFT DUE TO δe	H. TAIL CTR STA.	WING LIFT RES.	WING MOM. INT. LBS.	BODY LIFT LBS.	BODY MOM. INT. LBS.
1	A	.80	240	4.0	0	2.3	-1.9	-768	-1977	511.4	33476	-499561	6192	-274611
2	B	.80	240	4.0	-1.5	2.2	-1.8	-1074	-808	510.6	32675	-499013	6015	-289847
3	B	.80	246	4.0	0	2.2	-1.2	-894	-1507	509.5	32846	-504570	6055	-249099
4	B	.80	246	4.0	-1.5	2.1	-1.1	-1005	-73	506.1	32012	-509004	5986	-245725
5	C	.80	240	-1.0	0	-1.4	1.1	-6291	1004	508.5	-2846	-447769	-1108	-960654
6	C	.80	240	-1.0	1.5	-1.3	0	-6184	-25	509.1	-2044	-447316	-946	-945418
7	C	.80	246	-1.0	0	-1.4	.6	-6103	515	504.8	-2555	-447552	-1066	-962141
8	C	.80	246	-1.0	1.5	-1.3	-1.5	-5793	-519	526.1	-1770	-458116	-878	-944571
9	D	.80	240	-2.0	0	-2.5	2.3	-5889	1568	507.9	-1701	-507250	-2628	-1033328
10	D	.80	240	-2.0	3.0	-2.5	-1.8	-5677	-571	509.4	-1707	-305347	-2245	-822857
11	D	.80	246	-2.0	0	-2.7	1.3	-5661	274	504.2	-11035	-369027	-2597	-842210
12	D	.80	246	-2.0	3.0	-2.4	-1.7	-5731	-1326	506.9	-7103	-385239	-2240	-876919
13	A	.85	240	4.0	0	1.5	-2.7	4557	-3778	471.3	29270	-107524	6151	287704
14	A	.85	240	4.0	-3.0	2.1	-10.6	4301	-1423	490.8	2732	-103692	5790	270312
15	A	.85	246	4.0	0	1.5	-2.4	4681	-3116	484.1	29180	52240	6055	319893
16	A	.85	246	4.0	-3.0	1.2	-5.1	4419	-665	492.2	27368	42313	5677	299570
17	E	.80	246	-2.0	0	-17.6	24.6	-3156	2161	484.6	-14389	-23551	-2915	-244456
18	E	.80	246	-2.0	3.0	-17.4	-3.3	-2881	-247	493.4	-12701	-20605	-2571	-214919
19	E	.80	246	-2.0	0	-17.7	16.9	-2971	1311	488.9	-14057	-105777	-2853	-256782
20	E	.80	246	-2.0	3.0	-17.4	-4.0	-2581	-1028	494.3	-12297	-91701	-2494	-225729
21	F	.80	240	2.0	0	.8	-1.2	-2684	-115	510.2	19037	-497409	3242	-550666
22	F	.80	240	2.0	1.5	.9	-2.3	-2578	-2265	510.7	17829	-497757	3403	-535370

Table 4.1 Symmetrical Maneuvering Loads Summary (Sheet 1 of 4)

XV-5A SYMMETRICAL FLIGHT LOADING

POWER-OFF FLAPS UP
(CONTINUED)

F. Number	Roll Control Dia.	Pitch %	CG STA.	n_z	$\dot{\phi}$ R/sec.	$\dot{\phi}$ R/sec.	α Deg.	δe Deg.	H. Tail Lift Diff %	H. Tail Lift Diff %	H. Tail Lift Diff %	M Tail C/P	Wing Lift ABS.	Wing Mom. In-lbs.	Body Lift - lbs.	Body Mom. In-lbs.
23	F	.80	246	2.0	0	.217	.8	-1.0	-2566	-999	5015	18744	-391462	3201	-535250	
24	F	.80	246	2.0	1.5	.217	.9	-2.1	-2455	-2092	5087	9578	-38625	3327	-51828	
25	L	.87	246	2.0	0	.629	8.9	-10.4	1574	-1414	-53.3	FC84	-67659	3156	121142	
26	L	.87	246	2.0	3.0	.629	10.1	-7.2	1500	-3710	501.8	16792	-66758	3509	121142	
27	L	.87	246	2.0	0	.629	8.7	-7.2	1756	-1204	493.3	14743	13942	3105	121142	
28	L	.87	246	2.0	3.0	.629	10.0	-7.2	2001	-3597	503.2	16523	25560	3473	142693	
29	M	.81	246	-1.0	0	-398	-10.0	20.3	-2243	1587	492.2	-7136	-13343	-1408	-1456.7	
30	M	.81	246	-1.0	-3.0	-398	-12.0	14.6	-2478	3883	505.5	-9843	-14245	-1762	-142693	
31	M	.81	246	-1.0	0	-398	-9.8	14.5	-1987	1139	427.0	-6970	-51870	-1383	-159335	
32	M	.81	246	-1.0	-3.0	-398	-12.0	13.1	-2231	3532	505.2	-8749	-63489	-1752	-199877	

Table 4.1 Symmetrical Maneuvering Loads Summary (Sheet 2 of 4)

XV-5A SYMMETRICAL FLIGHT LOADINGS

MAXIMUM POWER-D₁

FLAPS UP

F	UNIT ON P-10 LINE	MACH NO.	CG STA.	MZ	δ P/SEC.	δ P/SEC.	α DEG.	δ ₀ DEG.	H. TAIL LIFT DUE TO CL	H. TAIL LIFT DUE TO δ ₀	H. TAIL CP STA.	WING LIFT LBS.	WING MOM. IN.-LBS.	BODY LIFT LBS.	BODY MOM. IN.-LBS.
1P	B	.25	240	4.0	0	.146	2.2	-1.9	-577	-1878	511.7	32763	-492367	5965	-292869
2P	B	.25	240	4.0	-1.5	.146	2.1	-1.1	-608	-93	506.5	36974	-314413	5681	-286532
3P	B	.25	240	-1.0	0	-.034	-1.5	1.1	-590	1044	513.1	-3257	-447074	-1312	-979910
4P	B	.25	240	-1.0	1.5	-.034	-1.4	-1.5	-5597	-519	506.1	-2808	-463525	-1103	-966837
5P	B	.25	240	-2.0	0	-.075	-2.9	2.3	-5523	1568	507.8	-12302	-302640	-2848	-970266
6P	B	.25	240	-2.0	3.0	-.075	-2.5	-1.8	-5421	-1326	506.9	-9998	-389975	-2420	-874977
7P	B	.28	240	4.0	0	1.5	17.8	-2.5	4675	-3778	474.1	29202	-107855	6205	277732
8P	B	.27	240	4.0	-5.0	1.5	17.8	-5.1	4531	-665	492.3	26729	42403	5553	291777
9P	E	.21	240	-2.0	0	-.265	-18.5	24.8	-3072	2061	473.9	-14956	-23850	-3032	-251817
10P	E	.20	240	-2.0	3.0	-.265	-18.1	-14.0	-2504	-1028	494.4	-12855	-95345	-2610	-233746

Table 4.1 Symmetrical Maneuvering Loads Summary (Sheet 3 of 4)

XV-5A SYMMETRICAL FLIGHT LOADING

FLAPS DOWN ($\delta_F = 45^\circ$, $\delta_A = 15^\circ$), POWER-OFF, SEA LEVEL

F Number	Point On V-n Diag.	Mach No.	CG Sta.	M_z	$\ddot{\theta}$ R/sec ²	$\dot{\theta}$ R/sec	α Deg	δ_E Deg.	H. Tail Lift Due To α	H. Tail Lift Due To δ_F	H. Tail CP Sta.	Wing Lift Lbs.	Wing Mom. In.-lbs.	Body Lift Lbs.	Body Mom. In.-lbs.
32	A	.16	240	2.0	0	1.5	12.7	-31.7	660	-1476	504.0	169115	-285542	2293	64535
34	"	.15	240	2.0	-3.0	1.5	13.6	19.6	609	803	494.1	14974	-252863	2074	56510
35	H	.16	246	2.0	0	1.5	18.7	-25.5	870	-1260	502.6	15567	-176684	2223	76130
36	H	.15	246	2.0	-3.0	1.5	18.6	25.2	814	1122	496.6	14521	-150041	1913	66416
37	S	.27	240	2.0	0	3.2	13.8	-7.1	-1782	-959	474.2	17520	-55009	1321	-147333
37	B	.27	247	2.0	-1.5	3.2	.8	.5	-1234	195	492.2	18712	-549318	1157	-157930
37	B	.27	247	2.0	0	3.2	1.2	-5.4	-1577	-731	494.5	17474	-425085	1254	-143271
40	S	.27	246	2.0	-1.5	3.2	.6	3.5	-1717	473	471.4	17557	-435813	1055	-155734
41	F	.27	240	1.0	0	3.1	-5.2	-3.4	-2627	-452	473.7	12362	-345555	-23	-236534
42	F	.27	240	1.1	1.5	3.1	-2.7	-12.0	-2514	-1607	473.7	3110	-547346	87	-225267
42	F	.27	246	1.0	0	3.1	-5.3	-3.4	-2424	-455	473.7	372	-477450	-114	-233279
42	F	.27	246	1.0	1.5	3.1	-2.8	-12.2	-2307	-1652	473.7	13108	-477421	571	-221074
45	L	.16	240	1.0	0	5.47	5.3	-10.1	-465	-453	472.3	10710	-202197	892	-20258
46	L	.16	240	1.0	3.5	5.47	7.0	-5.4	-314	-2687	472.3	10715	-215507	1226	-75
47	L	.16	246	1.0	0	5.47	5.5	-10.0	-245	-455	471.0	9035	-157824	864	-17874
48	L	.16	246	1.0	3.0	5.47	8.8	-6.6	-87	-2757	472.5	1167	-150286	1207	5742
49	-	.16	240	5	0	0	-7.8	14.5	-1770	658	471.1	1405	-169757	-476	-119147
50	-	.16	240	0	3.0	0	-4.6	-26.5	-1545	-1651	495.5	3361	-173138	-167	-82375
51	-	.16	246	0	0	0	-7.5	9.4	-1537	427	491.4	1656	-160118	-496	-112174
52	-	.16	246	0	3.0	0	-4.5	-28.7	-1302	-1980	475.5	3434	-152261	-154	-85488
53	-	.27	240	0	0	0	-7.8	11.9	-3941	658	492.1	17558	-554189	-1475	-324475
54	-	.27	240	0	1.5	0	-7.3	-3.7	-3828	-497	493.8	5636	-505880	-1311	-314078
55	-	.27	246	0	0	0	-7.8	3.2	-3709	428	492.5	4757	-475643	-1475	-333343
56	-	.27	246	0	1.5	0	-7.2	-5.8	-3592	-776	473.7	5472	-471115	-1304	-321450

Table 4.1 Symmetrical Maneuvering Loads Summary (Sheet 4 of 4)

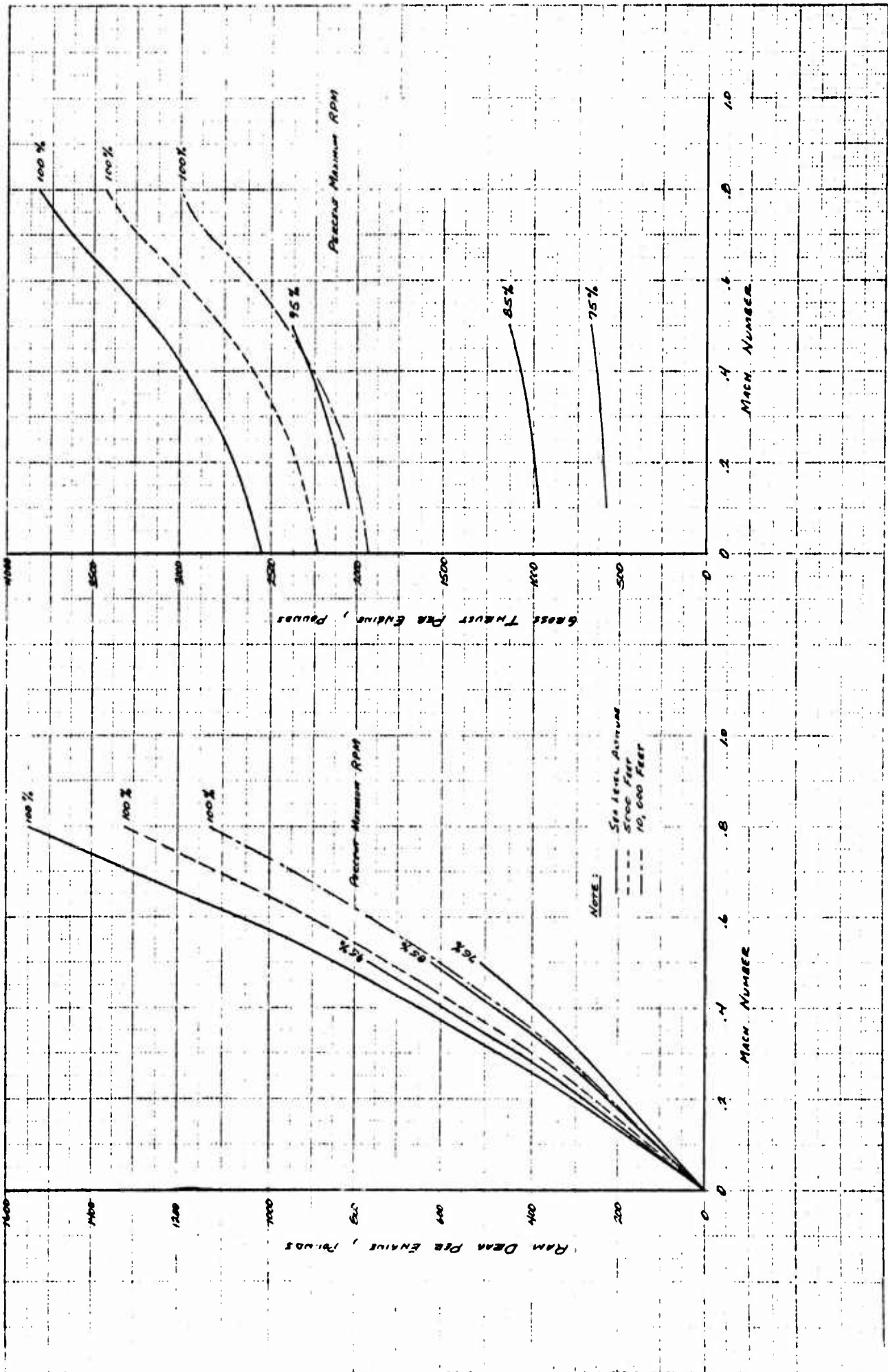

Figure 4.1 Engine Characteristics Gross Thrust and Ram Drag Per Engine

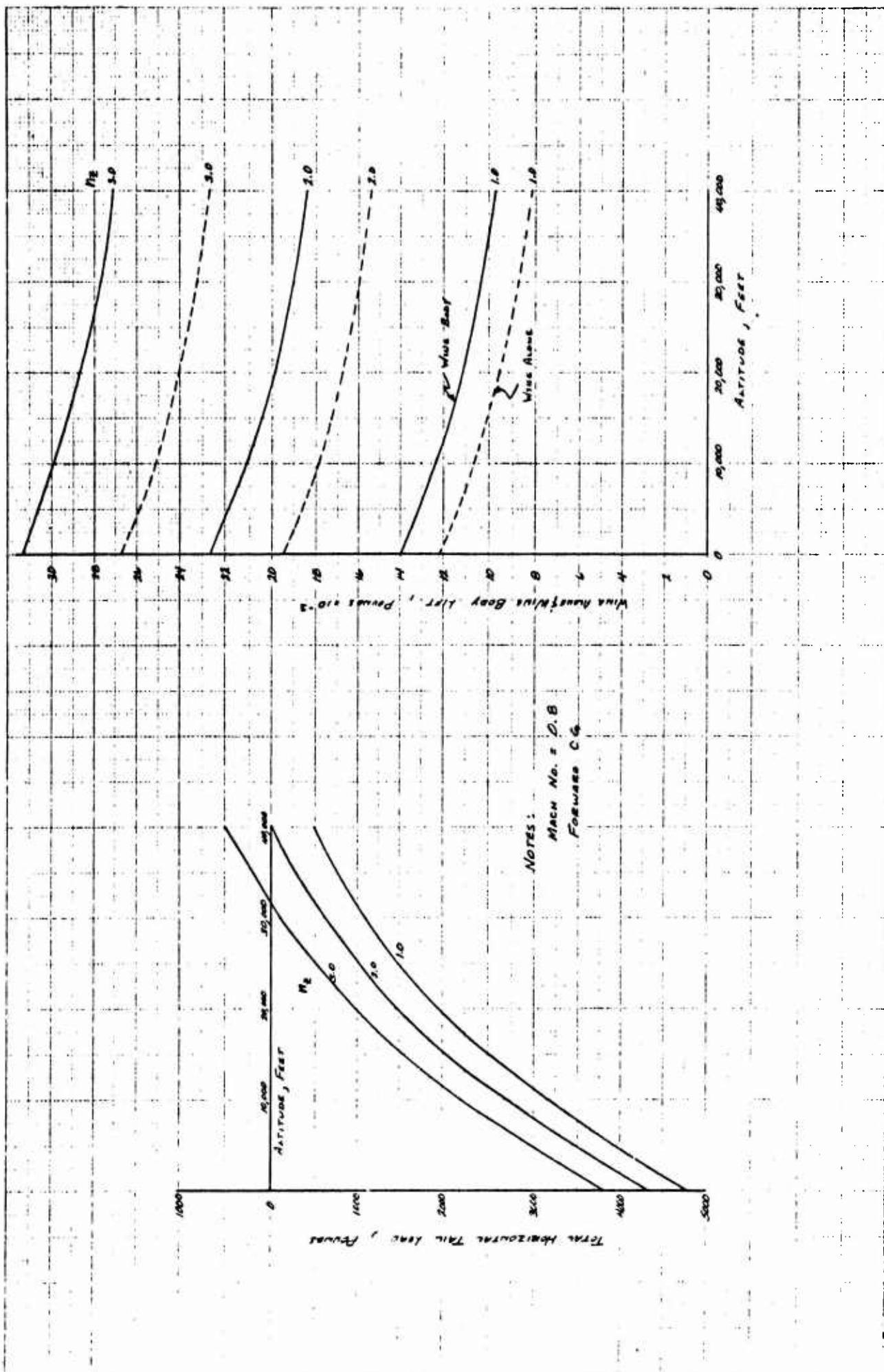

Figure 4.2 Symmetrical Flight Loading Curves Affects of Altitude on Wing, Wing Body, and Horizontal Tail Loads

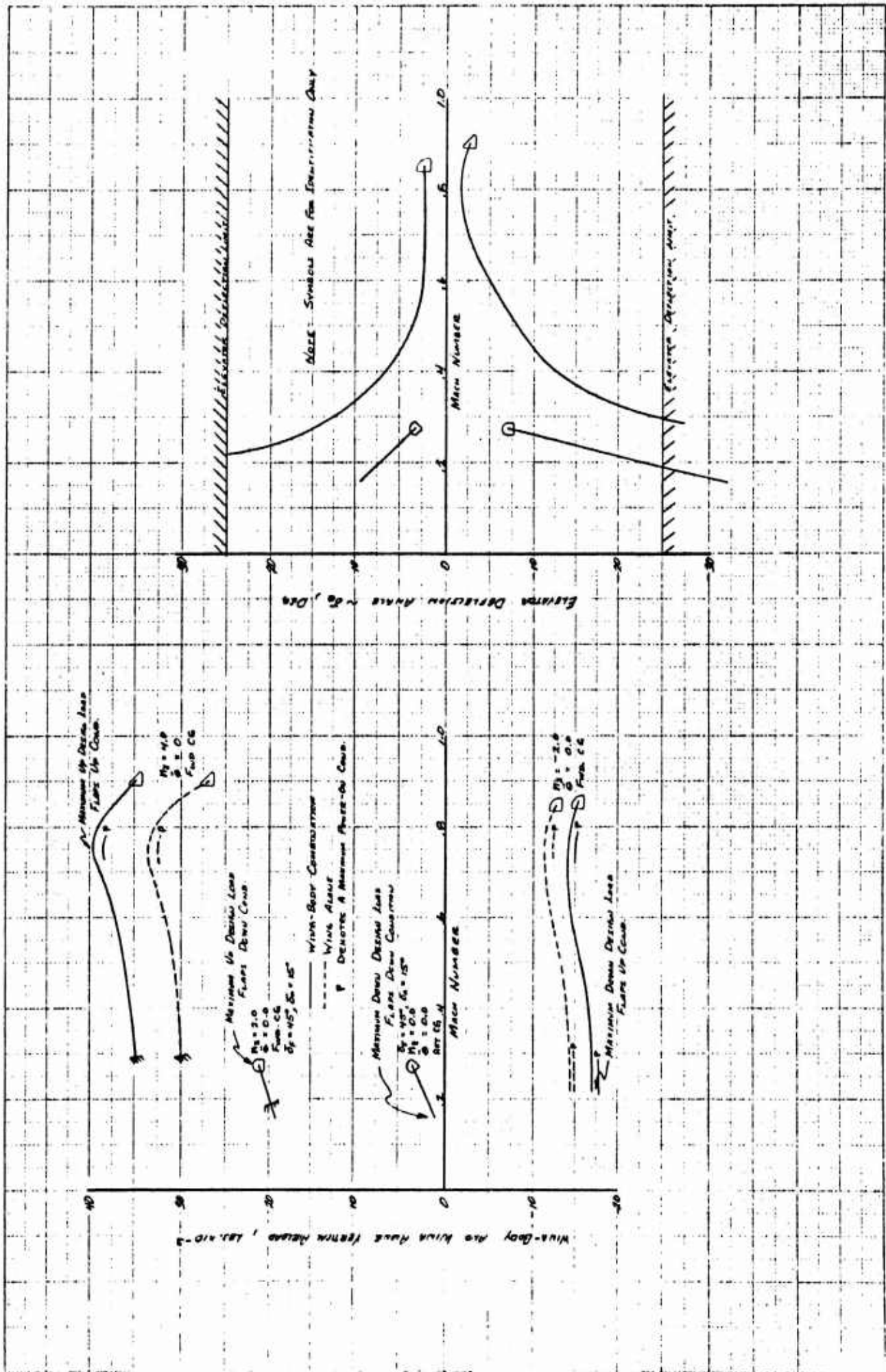

Figure 4.3 Symmetrical Flight Loading Curves Wing and Wing-Body Loads and Elevator Deflection

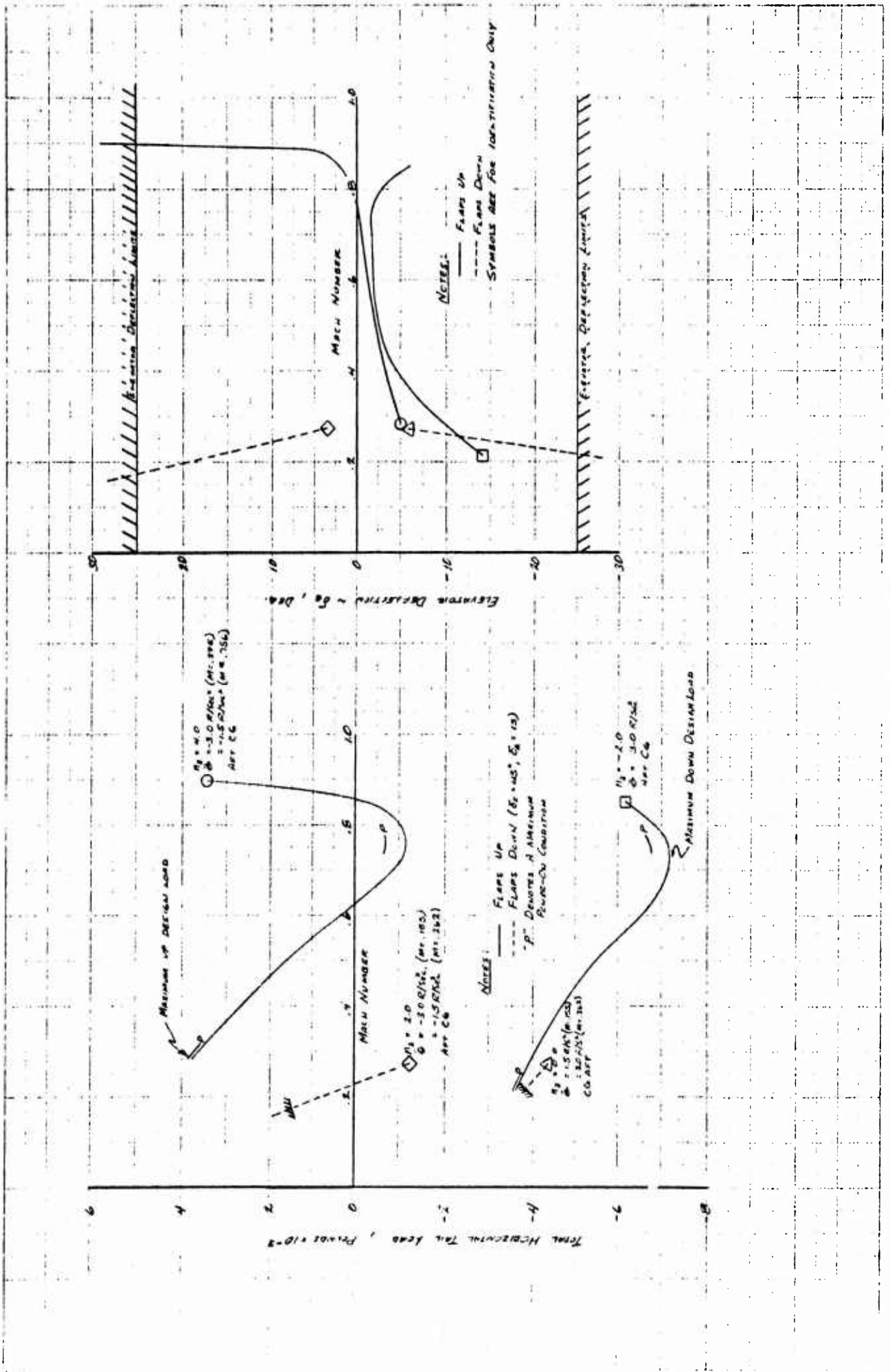

Figure 4.4 Symmetrical Flight Loading Curves

4.1.2 Rolling Maneuvers

4.1.2.1 Rolling Pull-Out

The results of the simplified analysis of this maneuver which were used in determining wing loads are presented in Figures 4.5 and 4.6. For each configuration (flaps up or down), wing panel point loads were calculated for (1) aileron reversed to neutral; (2) aileron reversed to the position producing maximum roll acceleration, and (3) aileron fully reversed to the opposite side (see Section 4.4.3 regarding limiting value of $n_z = 2.5$).

The three-degrees of freedom analysis of the rolling pull-out maneuver initially considered instantaneous control-stick displacement and rigid airplane aerodynamic characteristics. It was apparent from results thus obtained that the unsymmetrical loads were much higher than previously established design loads determined from rudder-induced yawing maneuvers and from lateral gusts. At high speeds, the peak sideslip angles were double those obtained from other unsymmetrical flight conditions. Further investigations were made to determine either a practical means of reducing the loads or flight boundaries within which the airplane could safely operate.

In order to realistically reduce the severity of the calculated roll condition, elastic values of aileron effectiveness and wing contribution to roll damping were used. The ratio of elastic to rigid values of these derivatives for the complete airplane (elastic wing) are shown in Figure 4.7. This change reduced the peak sideslip angle (β) by 10% at $M = 0.756$. A finite pilot response time of 0.1 seconds to initially deflect and also to subsequently reverse the stick (roll "check") was also considered and further reduced the peak value of β by 3%. In terms of $\beta \cdot q$ product, however, design values were still exceeded.

The critical portion of the maneuver occurs after initiating reversal of the stick. Therefore, "roll check" was evaluated by means of neutralizing the ailerons instead of reversing them. Upon investigating this type of maneuver, it was found that peak β occurred prior to control neutralization and produced only 92% of the design value at $M = 0.756$. However, in terms of $\beta \cdot q$, design values were still exceeded by 25% at a Mach number of 0.7.

In a further effort, flight velocity-and-altitude limits were determined for the maneuver checked by reversing the aileron. Vertical and lateral shear, bending, and torsion were determined at two critical fuselage

stations as a function of Mach number for sea-level altitude and as a function of altitude for a Mach number of 0.756. The study resulted in two speed-altitude limits based on structural strength capability: $M = 0.5$ at sea-level and $M = 0.756$ at 15,000 feet. Extrapolation of these results to a higher altitude indicate that no roll-maneuver speed restriction need be imposed above about 25,000 feet. At all speeds and altitudes, regardless of the means used to check the maneuver, it appears that as long as a lateral load factor of 0.8 is not exceeded, critical structural design loads will not be exceeded.

The curves of Figure 4.8 are typical of the results of the higher speed maneuvers. The figure shows the time history of a number of maneuver parameters for two Mach 0.5, sea-level conditions. As with most of the conditions investigated, the maneuver initiated at a load factor of 1.1 produces the maximum sideslip angle. Selected loads from the 1.1g condition of Figure 4.8 are shown in Figure 4.9.

The peak values of sideslip angle β , lateral load factor n_y , and vertical tail sideforce $F_{Y_{VT}}$ as a function of Mach number, vertical load factor, and means of checking the maneuver are shown in Figure 4.10. The values of β , n_y , and $F_{Y_{VT}}$ all peak at the same time during the maneuver, so the values shown in Figure 4.10 can be considered to act simultaneously. The horizontal tail rolling moment shown on the figure is not necessarily the maximum value at a particular Mach number but is the value that occurs simultaneously with the peak values of the other parameters. The curves are not extended through the .383 Mach number values because the nature of the maneuver changes considerably between the Mach numbers of .50 and .383.

The curves of Figure 4.10 show that a lateral load factor of 0.80 is not exceeded at sea-level Mach numbers less than 0.5 for the maneuver checked by aileron reversal and $M = 0.63$ for the maneuver checked by aileron neutralization. In Figure 4.11 it is shown that at $M = 0.756$, an n_y value of 0.8 is not exceeded at altitudes above 15,000 feet.

4.1.2.2 Steady-State Roll

The three-degrees of freedom time-history study of a "steady-state" roll maneuver, undertaken to determine the resulting structural loads, investigated sea-level flight conditions at a vertical load factor of 1.5. The particular Mach numbers were .383, .500, .575, .638, .700, and .756.

The curves of Figure 4.12 show a typical calculated time history of the roll maneuver. Shown are the time histories of the sideslip angle β , roll rate p , and yaw rate r , for the Mach .638 case. The cyclic nature of the curves is a result of the $[(g/V) \sin \varphi]$ term in the β equation.

All of the flight conditions resulted in similar time-histories with the exception of the .383 Mach case. The sideslip angle at this speed was reversed from that of the higher speeds. Because of the different nature of the roll maneuver the curves of Figures 4.13 and 4.14 were not faired through the values for this Mach number. Figure 4.13 shows the peak "steady-state" sideslip angle for the maneuver and the values of roll-rate and yaw-rate which occur at the same instant. The curves of Figure 4.14 show the peak values of lateral load factor n_y , vertical tail side force $F_{Y_{VT}}$ and horizontal tail rolling-moment $M_{x_{HT}}$ as a function of Mach number. Although the peak values of n_y and $F_{Y_{VT}}$ occur at the same time, it is not the time at which the peak value of $M_{x_{HT}}$ occurs.

From this analysis of the maneuver, it was determined that structural loads developed during this maneuver are at least equaled during other loading conditions.

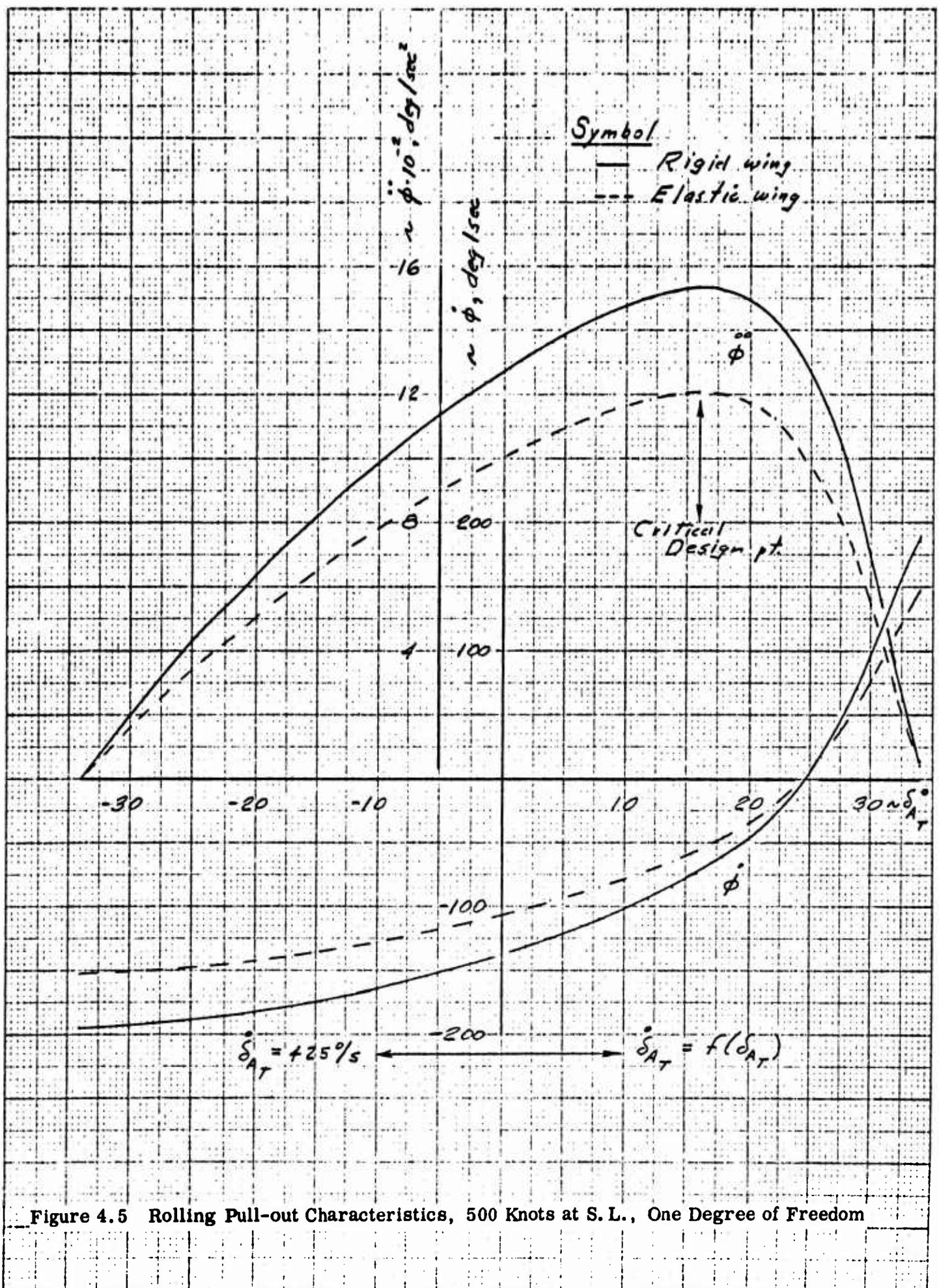

Figure 4.5 Rolling Pull-out Characteristics, 500 Knots at S. L., One Degree of Freedom

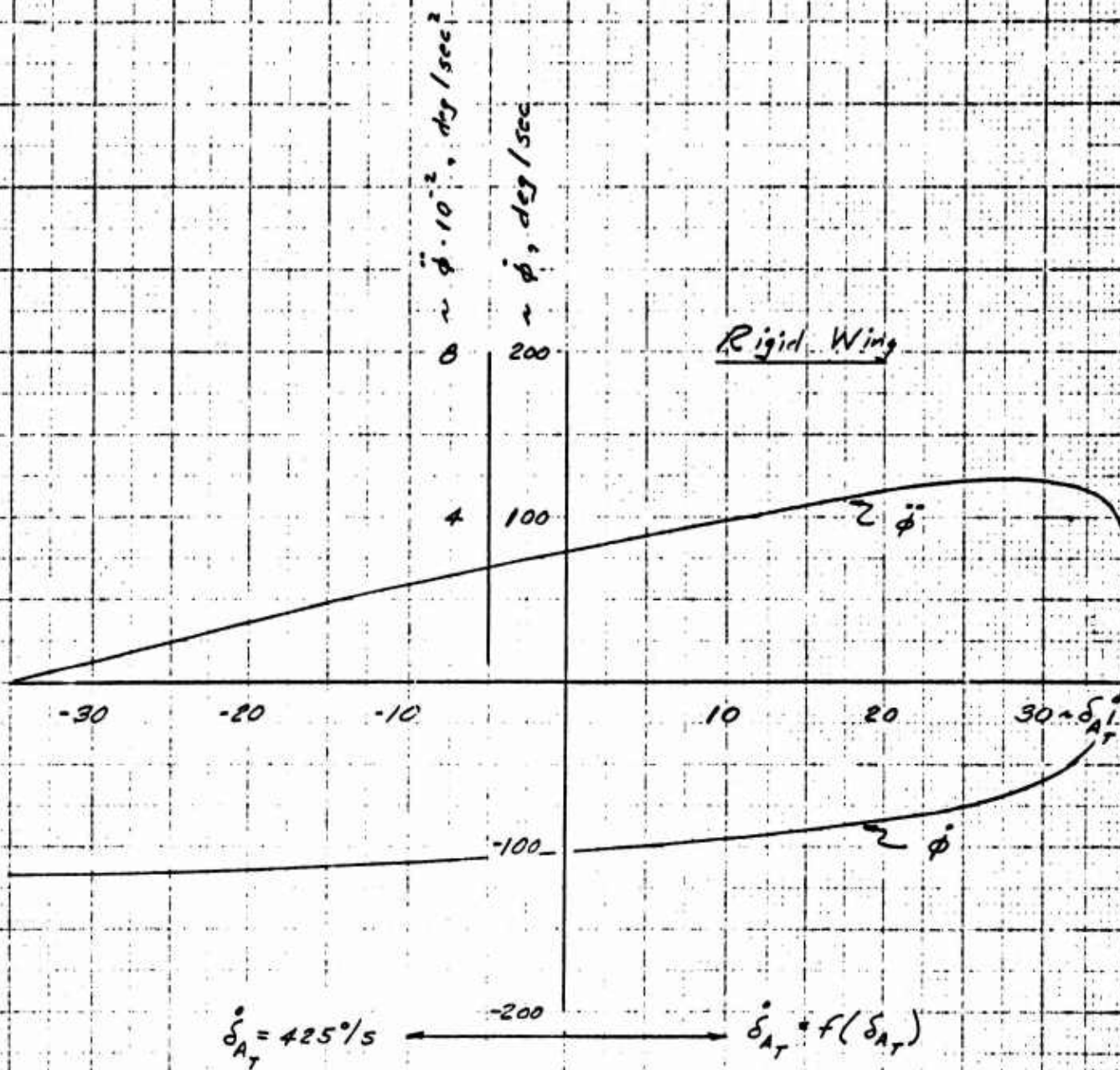

Figure 4.6 Rolling Pull-out Characteristics, 180 Knots at S. L., One Degree of Freedom, Flaps Extended 45 Degrees

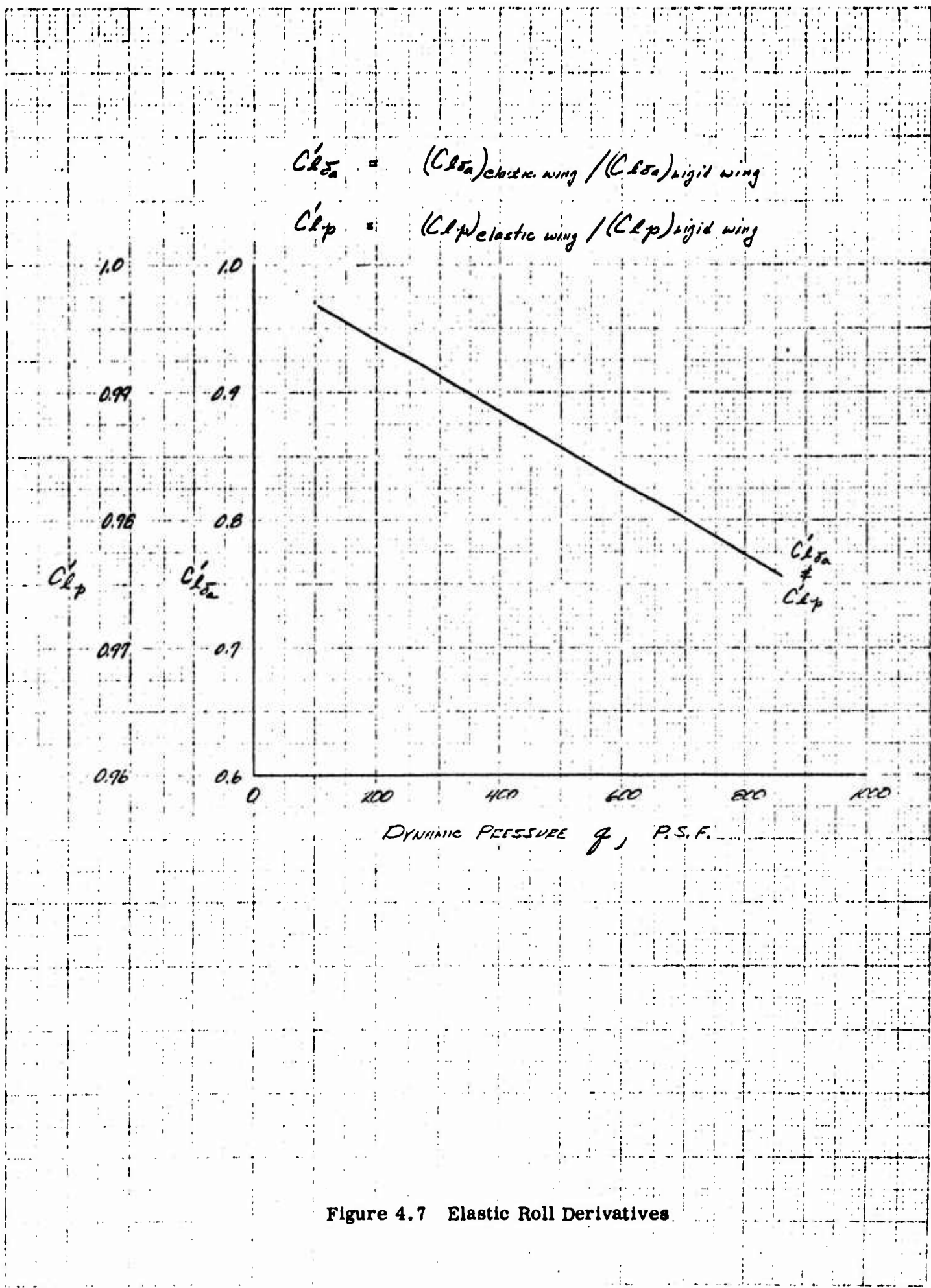

Figure 4.7 Elastic Roll Derivatives

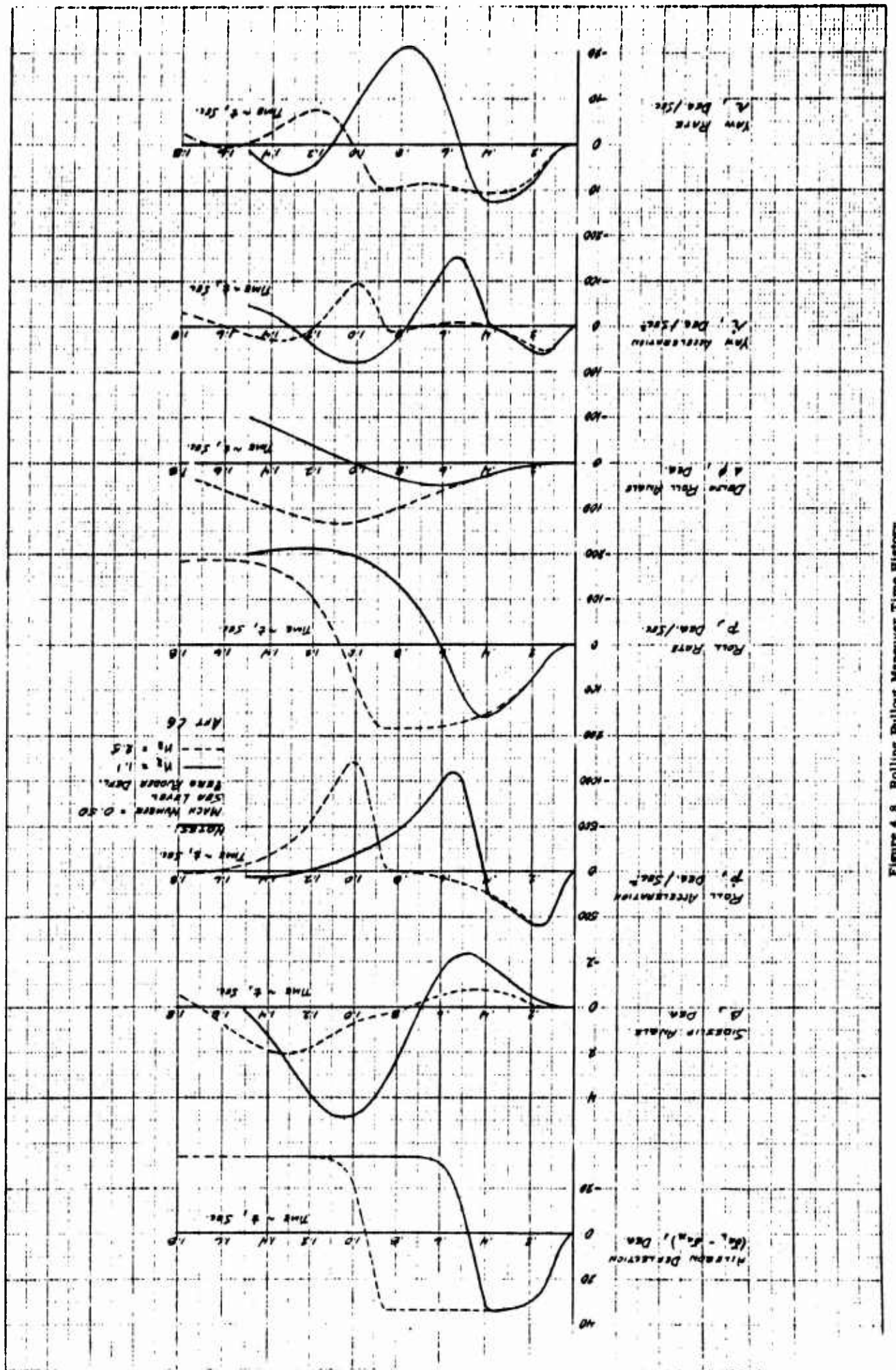
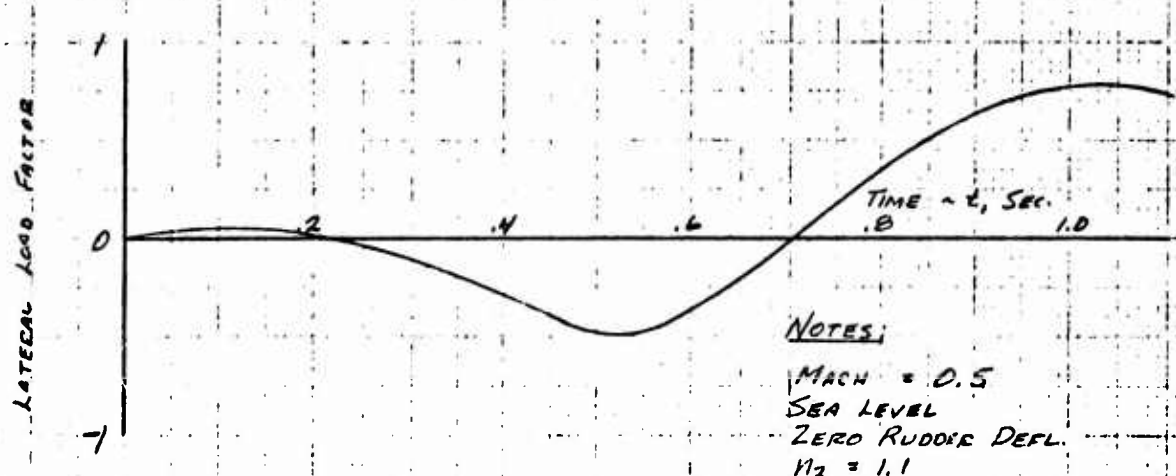
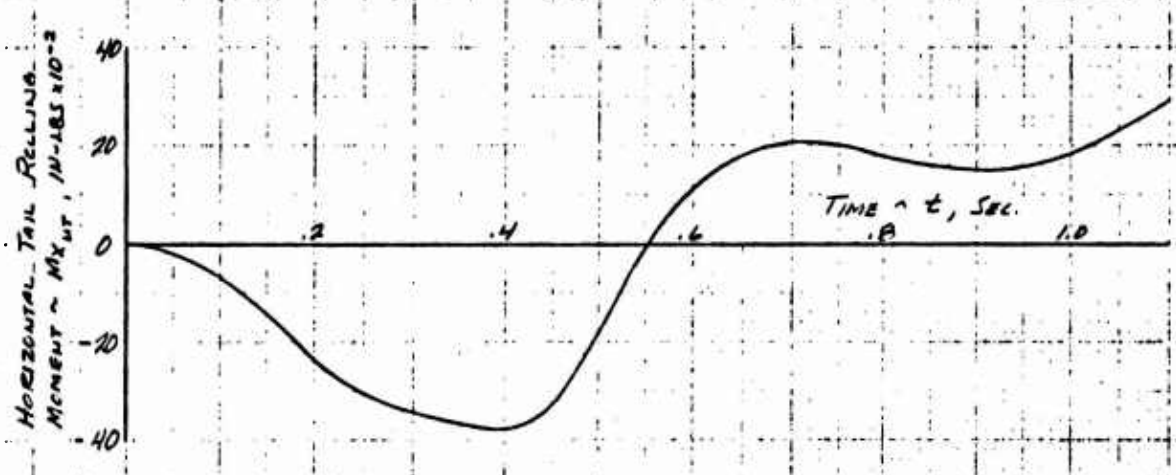
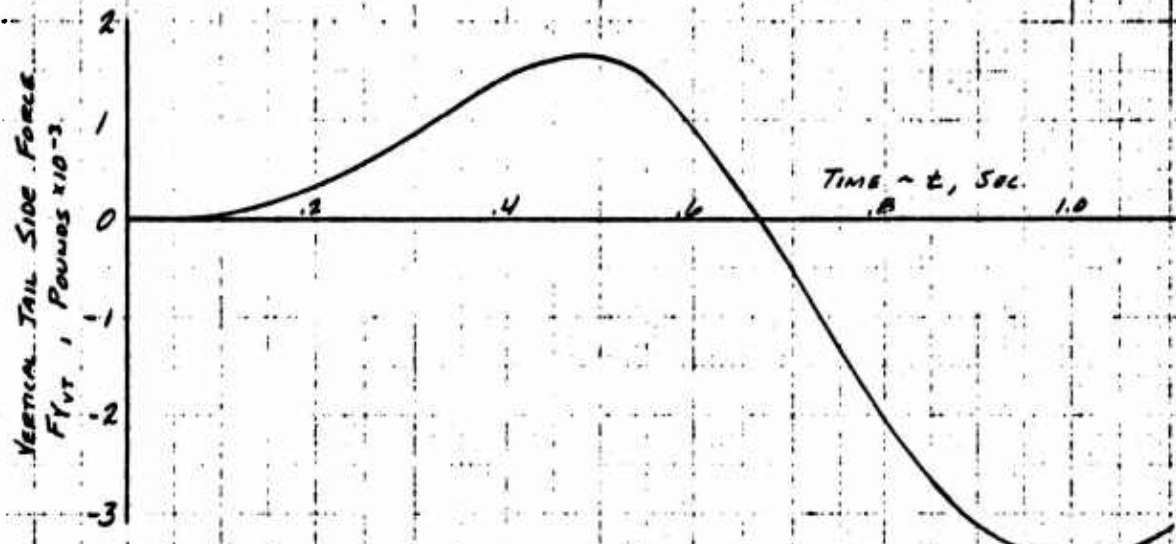

Figure 4.8 Rolling Pullout Maneuver Time History



NOTES:
 MACH = 0.5
 SEA LEVEL
 ZERO RUDDER DEFL.
 $V_2 = 1.1$
 AFT CG

Figure 4.9 Rolling Pull-out Maneuver Time History.

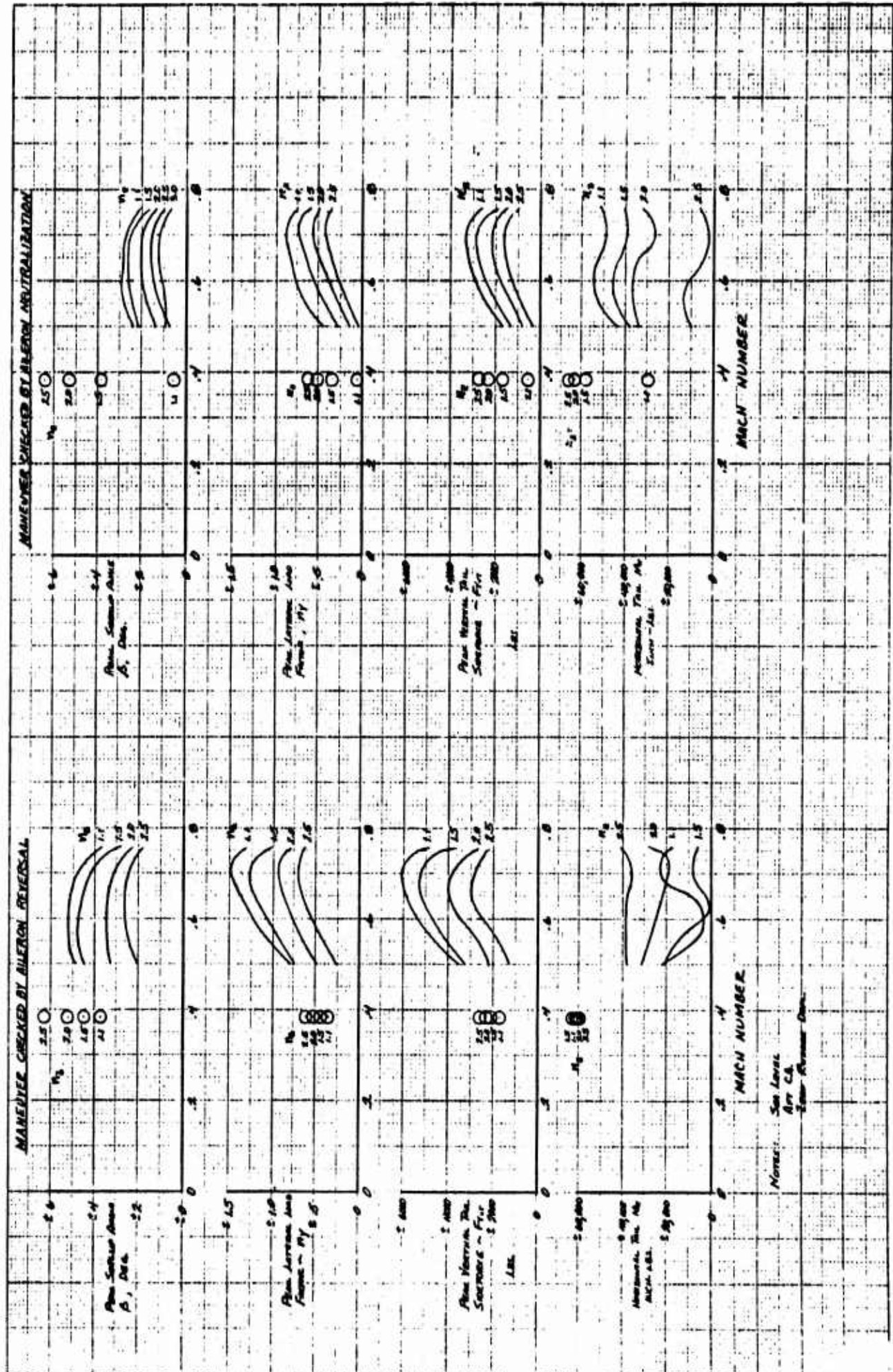

Figure 4.10 Loading Curves Rolling - Pullout Maneuver

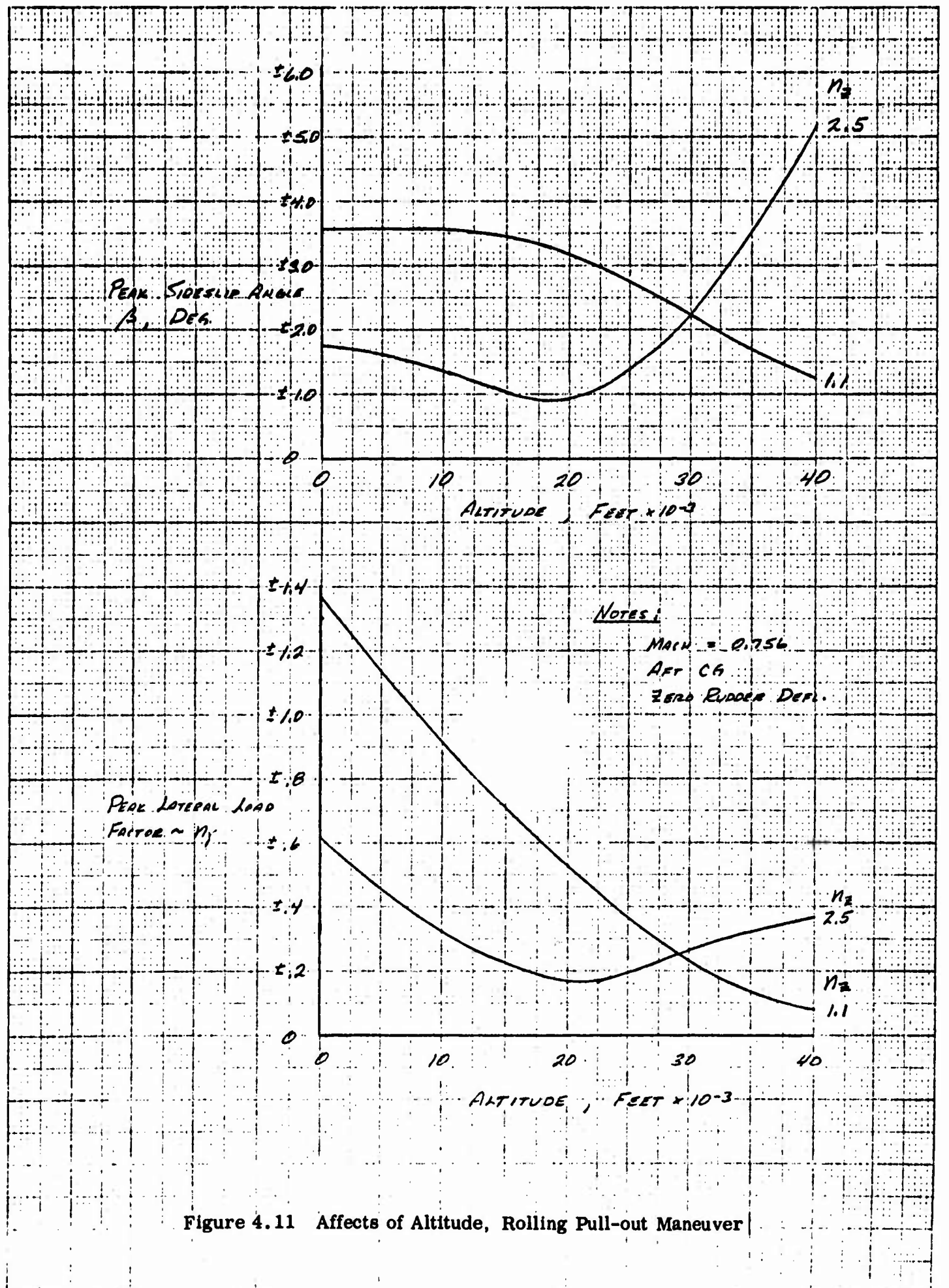

Figure 4.11 Affects of Altitude, Rolling Pull-out Maneuver

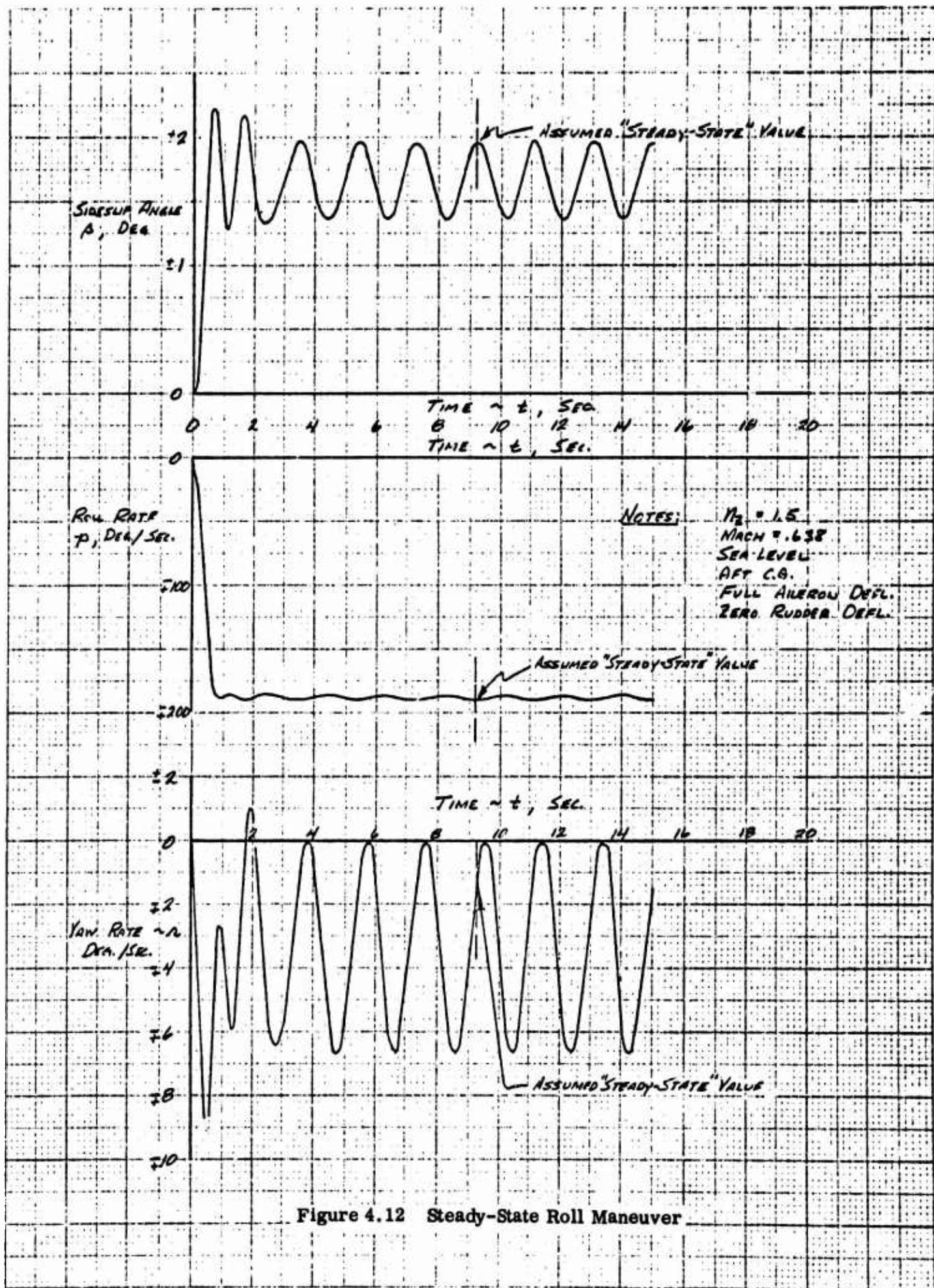

Figure 4.12 Steady-State Roll Maneuver

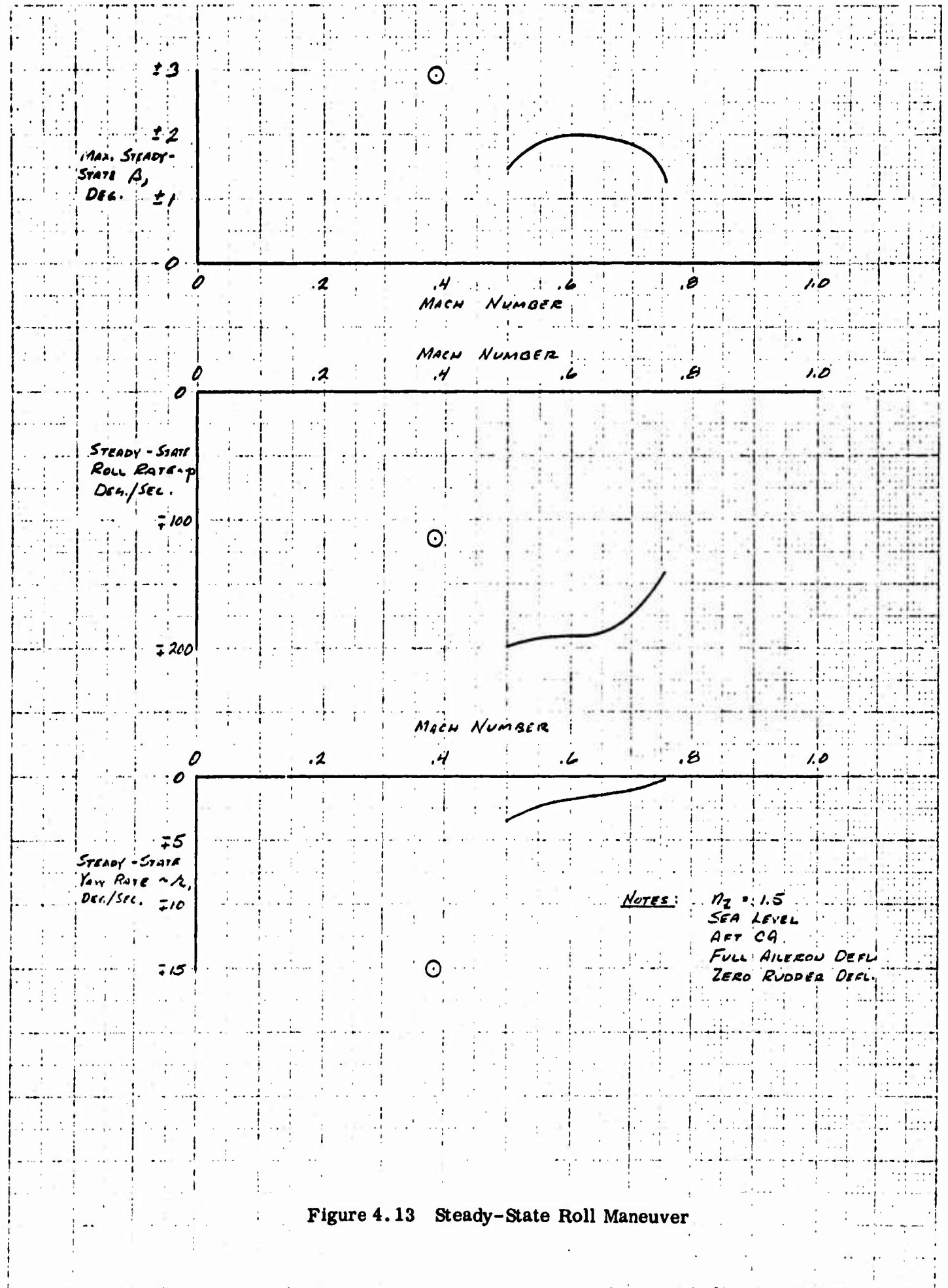

Figure 4.13 Steady-State Roll Maneuver

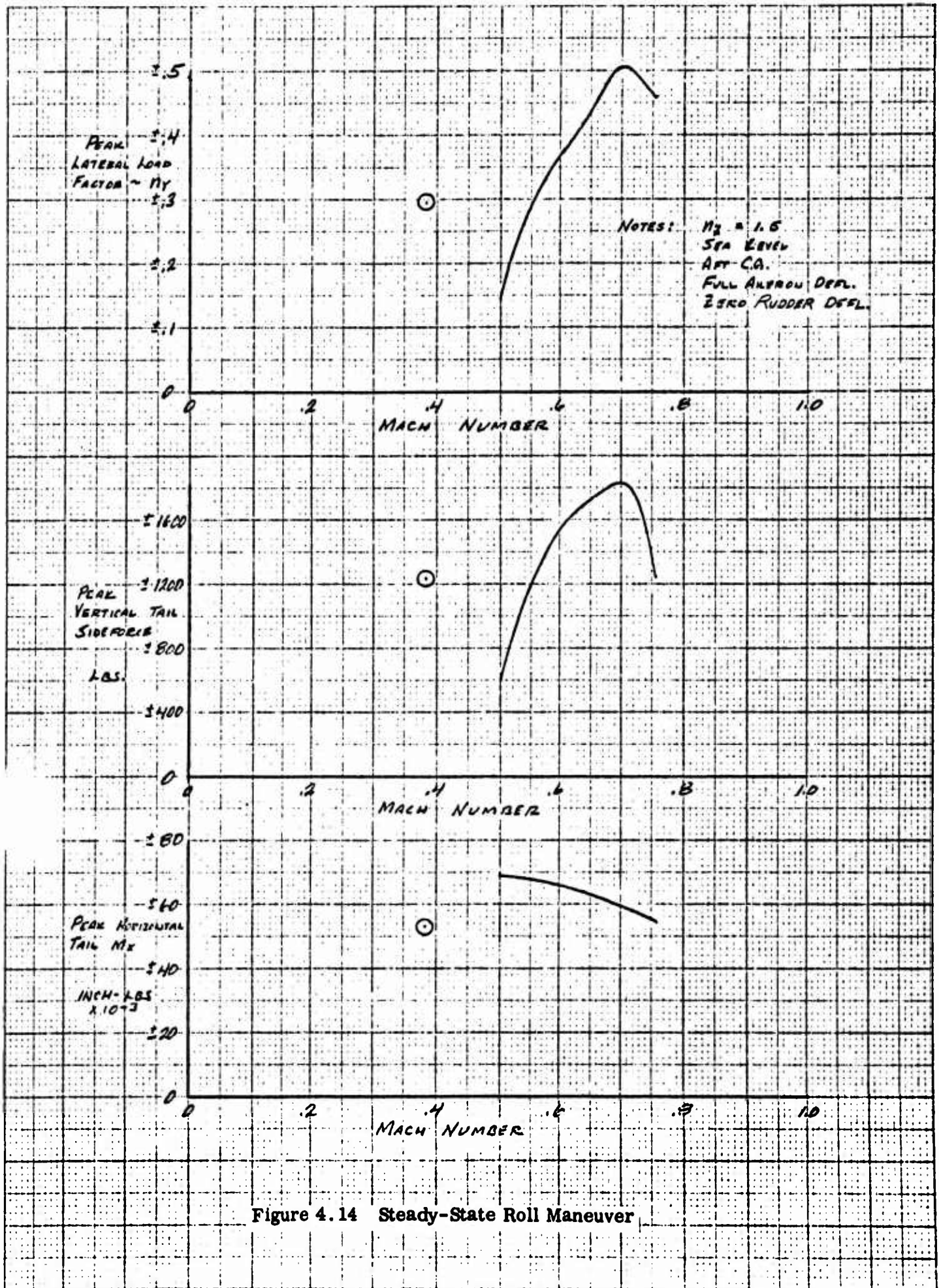

Figure 4.14 Steady-State Roll Maneuver

4. 1. 3 Yawing Maneuvers

Results from the solution of the equations defining the static balance of the airplane during rudder-induced and lateral gust conditions are presented in Table 4.2 for sea-level altitude. Selected parameters of the table are shown as a function of Mach number in Figures 4.15 through 4.17. Figure 4.15 shows various flight parameters for the maneuvers and Figure 4.16 presents the airplane lateral load factor and empennage loading. Figure 4.17 is included to show loading-envelope curves of the same parameters as are shown in Figure 4.16.

Typical solutions of the dynamic equations defining the motion of the airplane which result from a rudder-kick are shown in Figure 4.18. The values of the parameters shown in the figure agree very well with the values calculated by means of the static balance equations. Figure 4.19 gives values of the overswing to steady-state sideslip ratio as a function of Mach number. The figure validates the 1.5 ratio specified in the Structural Design Criteria (Reference 1).

XV-SA RUDDER MANEUVER AND LATERAL GUST FLIGHT CONDITIONS

* ~ ASTERISK ON COND. NO. DENOTES CG @ 2400 OTHERWISE CG IS AT 2460

COND. No.	MACH No.	PILOT FORCE LBS.	\dot{M}_y	$\ddot{\phi}$ R/SEC ²	$\ddot{\psi}$ R/SEC ²	δ_n DEG.	β DEG.	V. TAIL C/P STA.	V. TAIL C/P W.L.	VERT. TAIL SIDE FORCE LBS.	H. TAIL ROLL. MOM. IN. - LBS.	BODY ROLL. MOMENT IN. - LBS.	BODY YAW MOMENT IN. - LBS.	WING ROLL MOMENT IN. - LBS.	WING YAW MOMENT IN. - LBS.
LATERAL GUST CONDITION															
L6-1*	.756	-	+60	-44	1.23	0	1.63	466.6	160.1	+2521	-47365	-6384	-278105	137048	-28237
L6-2	.756	-	+60	-46	.97	0	1.63	466.6	160.1	+2521	-49811	-7581	-295997	138307	-41514
L6-3*	.638	-	+90	-2.28	2.38	0	3.235	465.1	160.0	+3878	-64578	-9353	-407487	113575	65403
L6-4	.638	-	+90	-2.27	2.07	0	3.235	465.1	160.0	+3878	-68166	-1107	-433702	115150	68298
L6-5*	.383	-	+50	-2.42	1.34	0	5.395	461.8	160.0	+2467	-37478	-4508	-112388	19586	-38390
L6-6	.383	-	+50	-2.40	1.17	0	5.395	461.8	160.0	+2467	-37478	-5354	-202023	18061	-35448
RUDDER KICK															
AF-1*	.756	200	-10	.77	-1.17	2.88	0	525.3	157.5	-902	12049	-	-	-	-
AF-2	.756	200	-10	.73	-1.10	2.88	0	525.3	157.5	-902	12049	-	-	-	-
AF-9*	.638	200	-13	.99	-1.23	4.19	0	472.7	157.4	-1169	12092	-	-	-	-
AF-10	.638	200	-13	.94	-1.15	4.19	0	472.7	157.4	-1169	12092	-	-	-	-
AF-17*	.383	300	-21	1.58	-2.02	17.91	0	469.5	157.3	-1948	17056	-	-	-	-
AF-18	.383	300	-21	1.50	-1.94	17.91	0	469.5	157.3	-1948	17056	-	-	-	-
STEADY - SIDESLIP															
AF-3*	.756	300	+67	0	0	3.97	2.19	432.7	161.6	+2151	-47159	-8594	-374403	160837	-40128
AF-4	.756	300	+81	0	0	3.91	2.56	440.3	161.3	+2733	-61828	-11901	-444648	203708	-66360
AF-11*	.638	300	+47	0	0	5.96	2.34	454.1	163.8	+1147	-29581	-6774	-275113	94889	49558
AF-12	.638	300	+51	0	0	5.94	2.48	455.5	163.2	+1322	-35219	-8530	-333077	109201	56053
AF-19*	.383	300	+45	0	0	17.08	7.10	451.5	163.6	+1390	-33069	-5934	-258504	109709	-35458
AF-20	.383	300	+49	0	0	17.03	7.52	449.8	163.2	+1586	-36020	-7462	-291331	121919	-32030

Table 4.2 Lateral Loads Summary (Sheet 1 of 2)

XY-SA RUDDER MANEUVER AND LATERAL GUST FLIGHT CONDITIONS

(CONTINUED)

COND No.	Mach No.	Pilot Force lbs.	$\dot{\gamma}$	$\ddot{\gamma}$	δ_r	δ_r	$\dot{\delta}_r$	$\ddot{\delta}_r$	V. Tail CP STA.	V. Tail CP W.L.	VERT. TAIL SIDEFORCE LBS.	H. TAIL ROLL MOM. IN.-LBS.	Body Roll Moment IN.-LBS.	Body Yaw Moment IN.-LBS.	Wing Roll Moment IN.-LBS.	Wing Yaw Moment IN.-LBS.
DYNAMIC OVERSWING																
AF-5*	.756	200	+72	.09	.62	2.53	2.19	448.7	160.9	+2602	-53183	-8594	-374403	184503	-38015	
AF-6	.756	200	+85	-.10	.57	2.47	2.56	452.3	160.7	+3184	-67852	-11901	-464648	217110	-65167	
AF-13*	.638	200	+53	-.74	.59	3.86	2.34	460.4	161.6	+1732	-35627	-6674	-295113	82254	47367	
AF-14	.638	200	+57	-.88	.54	3.84	2.48	460.8	161.4	+1907	-41265	-8530	-333077	88433	52452	
AF-21*	.383	300	+78	-3.30	.77	16.66	10.65	457.2	161.6	+3059	-58132	-89011	-387955	38671	-75800	
AF-22	.383	300	+84	-3.63	.67	16.59	11.28	456.2	161.5	+3353	-62558	-11192	-436976	37761	-74110	
RUDDER NEUTRALIZATION																
AF-7*	.756	-	+54	-.70	1.08	0	1.46	466.6	160.1	+2263	-42510	-5730	-249602	107225	-26752	
AF-8	.756	-	+62	-.66	1.00	0	1.71	466.6	160.1	+2639	-62128	-7934	-309765	135805	-44240	
AF-15*	.638	-	+43	-.93	1.17	0	1.56	465.1	160.0	+1873	-31179	-4516	-196742	63259	33039	
AF-16	.638	-	+46	-.89	1.09	0	1.53	465.1	160.0	+1986	-34960	-5686	-222051	72801	37369	
AF-23*	.383	-	+65	-1.51	1.92	0	7.10	461.8	160.0	+3247	-49332	-5934	-258504	109709	-35459	
AF-24	.383	-	+69	-1.43	1.82	0	7.52	461.7	160.0	+3438	-52236	-7462	-291331	121919	-32031	

Table 4.2 Lateral Loads Summary (Sheet 2 of 2)

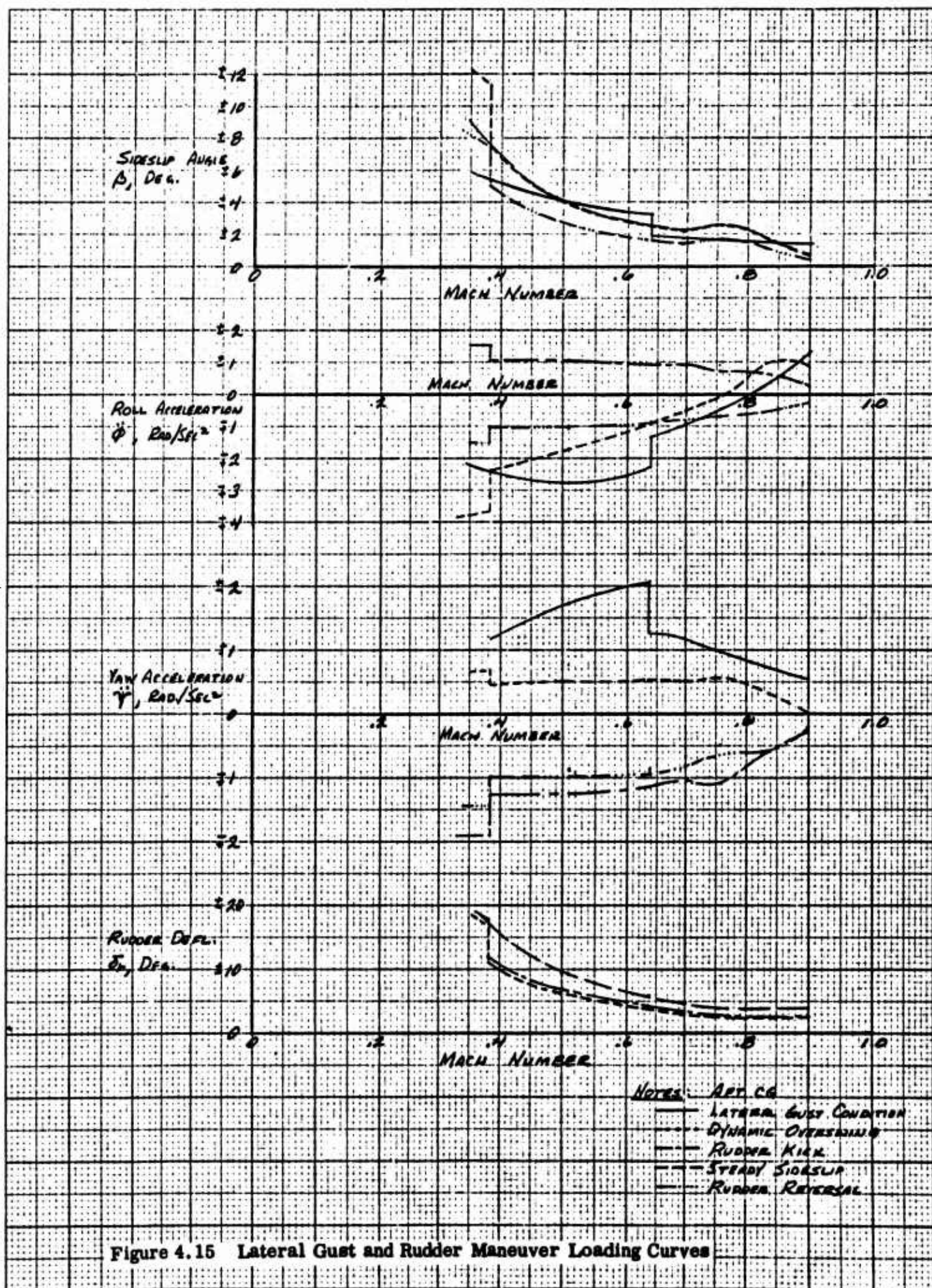
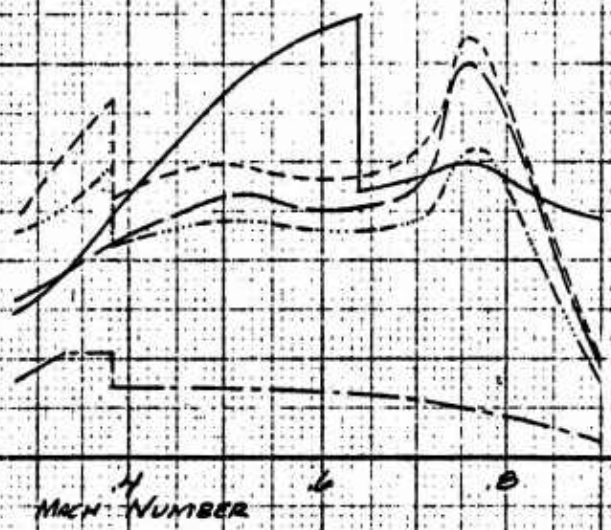
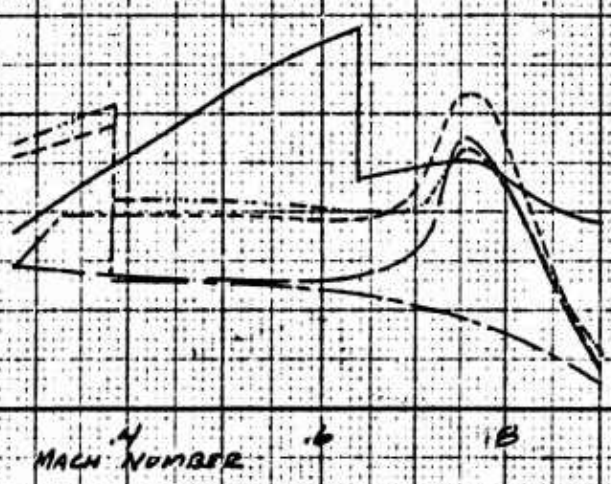

Figure 4.15 Lateral Gust and Rudder Maneuver Loading Curves

LATERAL LOAD
FACTOR $\times 10^4$



VERTICAL TAIL
SIDE FORCE
FYT
LBS



HORIZONTAL TAIL
MX, IN.-LBS

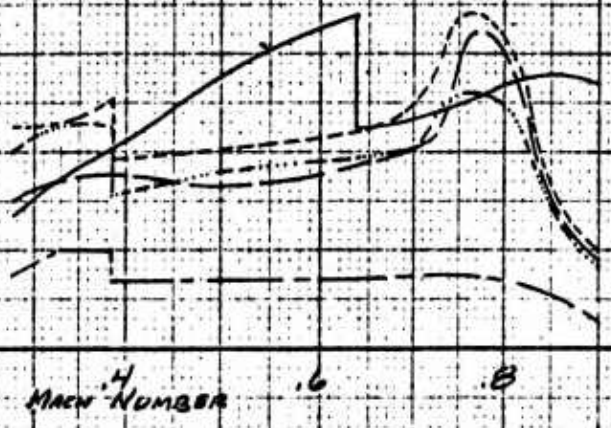

NOTES: AFT CA.
 ——— LATERAL GUST CONDITION
 - - - DYNAMIC OVERSWING
 - · - RUDDER KICK
 · · · STEADY SIDESLIP
 - - - RUDDER REVERSAL

Figure 4.16 Lateral Gust and Rudder Maneuver Loading Curves

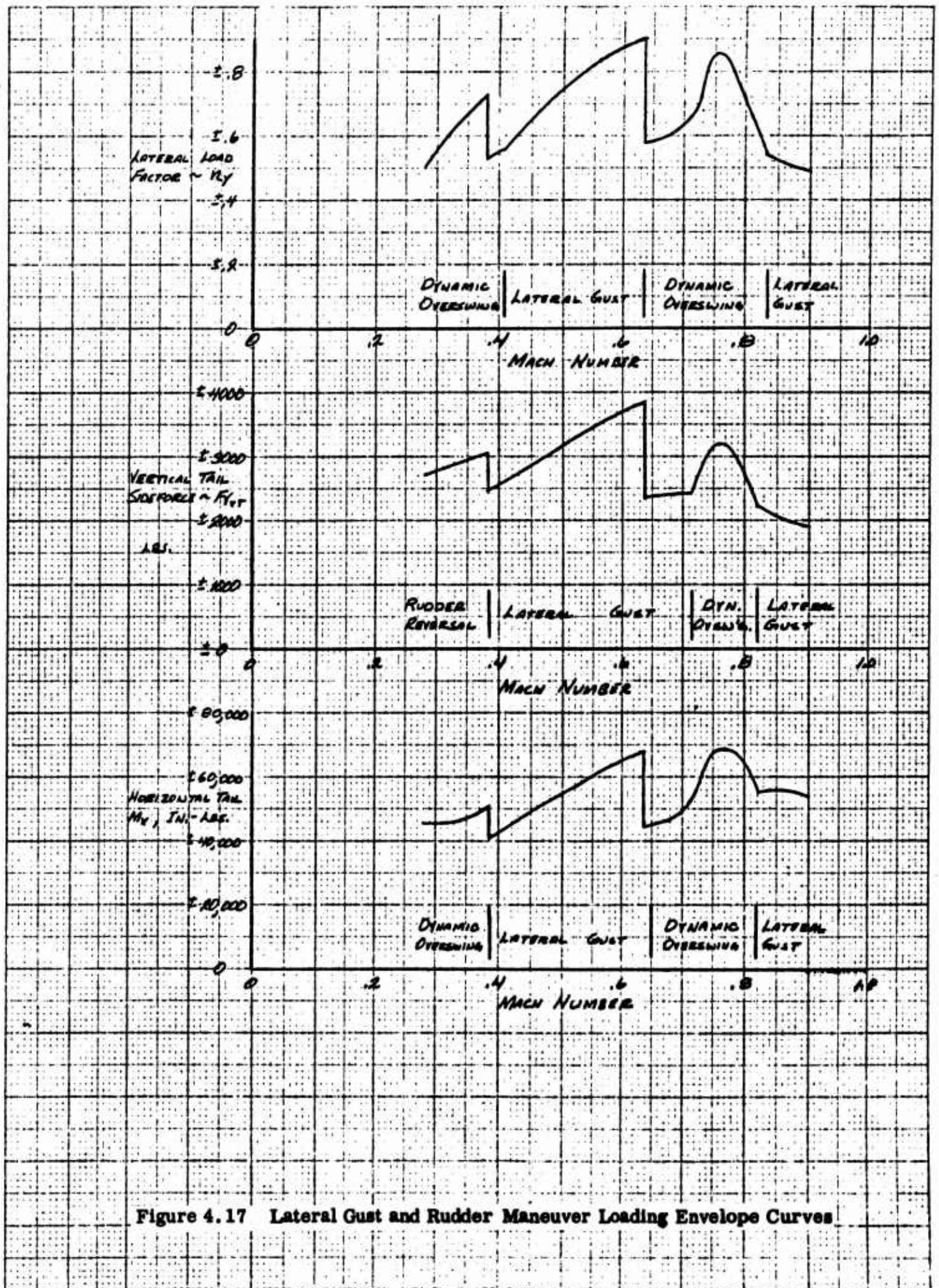

Figure 4.17 Lateral Gust and Rudder Maneuver Loading Envelope Curves

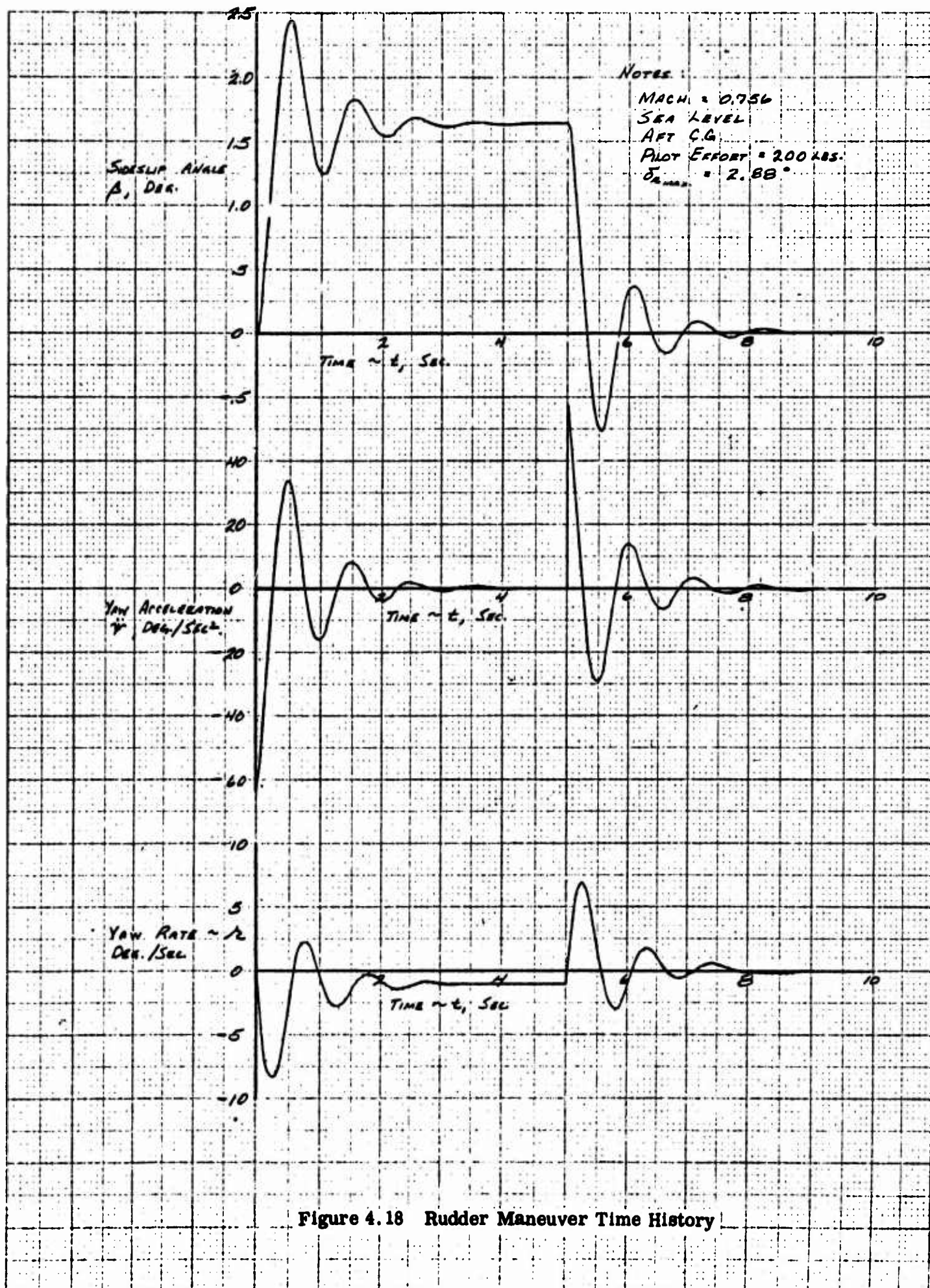

Figure 4.18 Rudder Maneuver Time History

NOTES:

FWD AND AFT CG

ALTITUDE = SEA LEVEL FOR $M \leq 0.756$

DYNAMIC PRESSURE = 846 FOR $M > 0.756$

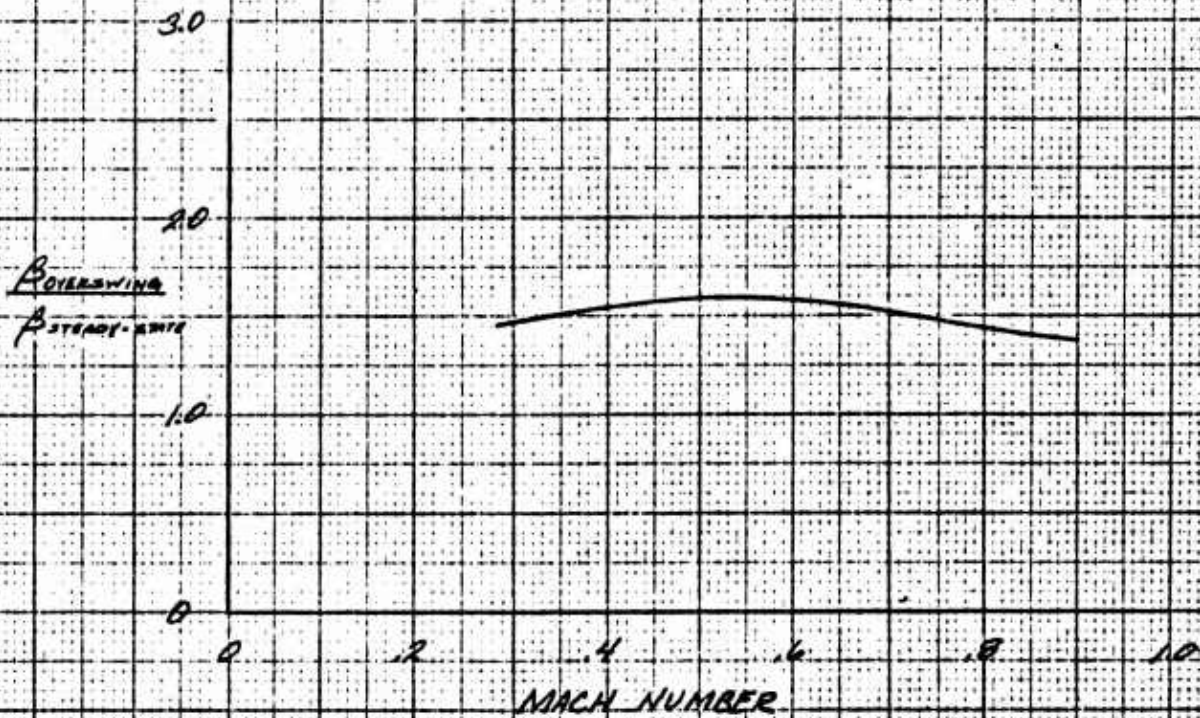

Figure 4.19 Rudder Maneuver, Calculated Ratios of Overswing to Steady-State Sideslip Angles

4.2 SPIN RECOVERY

Utilizing the equations and parameters shown in Section 3.2, the appropriate angle of attack and angle of sideslip are, respectively, 45 and ± 11.4 degrees. Estimating force coefficients with the aid of References 8 and 9, a speed of 125 knots was found which satisfied the required angular rates, above attitudes and produced a vertical load factor of 2.0. The resultant calculated subdivision of loading plus the components of spin chute force (1040 lbs.) which were used in the "Fuselage Shear and Moment Program" are as follows:

Fuselage

Distributed loading for $F_z = 1699$ lbs.

Distributed loading for $F_y = 695$ lbs.

Wing Fwd. Spar (F. Sta. 214, BL 0, WL 101.27)

$F_x = 2136$ lbs., $F_y = 0$, $F_z = 3157$ lbs.

$M_{x_{113}} = -23,973$ in-lbs., $M_y = 67,825$ in-lbs., $M_z = 0$

Wing Aft Spar (F. Sta. 296.5, BL 0, WL 101.27)

$F_x = 0$, $F_y = 0$, $F_z = 10,264$ lbs.

$M_{x_{113}} = -53,968$ in-lbs., $M_y = 0$, $M_z = 0$

H. Tail (F. Sta. 506.64, BL 0, WL 206)

$F_z = 3280$ lbs., $M_{x_{206}} = -1849$ in-lbs.

V. Tail (F. Sta. 459.6479, BL 0, WL 113)

$F_y = -302$ lbs.

Spin Chute (F. Sta. 486.39, BL 0, WL 113)

$F_x = 593.7$ lbs., $F_y = -291.9$ lbs., $F_z = 802.4$ lbs.

$M_{x_{113}} = -1128$ in-lbs., $M_y = -18,179$ in-lbs., $M_z = -5779$
in-lbs.

Note that for above:

- a) Axis system of Figure 4.21
- b) Chute reactions were transferred from the actual attachment point (F. Sta. 488.08, BL 0, WL 109.14) to the specified reference coordinates.

4.3 GUST PERTURBATION

4.3.1 Vertical Gusts

The effects of vertical gusts were found less critical than symmetrical maneuvers.

4.3.2 Lateral Gusts

The loads resulting from lateral gusts are discussed with the yawing flight maneuvers, Section 4.1.3.

4.4 WING LOADS

4.4.1 Symmetrical Flight, Flaps Retracted

Rigid-body wing loads which correspond to perimeter points (A-E) of the V-n diagram of Figure 3.1 are presented in Tables 4.3 through 4.7.

Since the most critical of these conditions was designation F-1, the corresponding results (EF-1) for the elastic wing are presented in Table 4.8. Associated twist (negative for "wash-out") is shown in Figure 4.20.

The above loads data are related to the panel point geometry of Figure 3.8 and, in groups of four, provide the effect of c. g location and pitching acceleration. As a typical example for point B of the V-n diagram:

F-1 : Fwd. c.g. (F. Sta. 240), $\ddot{\theta} = 0$

F-2 : Fwd. c.g. (F. Sta. 240), $\ddot{\theta} = \text{finite value}$

F-3 : Aft. c.g. (F. Sta. 246), $\ddot{\theta} = 0$

F-4 : Aft. c.g. (F. Sta. 246), $\ddot{\theta} = \text{finite value}$

Beneath each column of data are also shown specific auxiliary information. With respect to the wing root (BL = 24) and rear spar (F. Sta. 296.5). . . shear (S), bending (M), and torsion (T) produced by points (P) = 100-124 are noted. Although applied loads at points 127-131 are shown separately, their effects are appropriately included at P = 100-124. Torsion, T, is referenced to the rear spar and assumes a positive wing leading-edge "up" sign convention as do the hinge moments for the aileron (AHM) and flap (FHM). Centroids of T and M are designated by \bar{X} and \bar{Y} in terms, respectively, of F. Sta. (actual) and lateral distance from the wing root. The total root conditions for the exposed wing, as an integral unit, may be found by summation of S, M, and T with their respective incremental values (i. e. ΔS , ΔM , ΔT) plus the contributions of points P = 127 and 128.

<i>P</i>	<i>F-1</i>	<i>F-2</i>	<i>F-3</i>	<i>F-4</i>
100	1.3406978E 02	1.3035559E 02	1.3133965E 02.	1.2754252E 02
101	3.1077191E 02	3.0198749E 02	3.0398934E 02	2.9486027E 02
102	3.4835612E 02	3.3225394E 02	3.3716263E 02	3.2064232E 02
103	5.2053372E 02	5.0225623E 02	5.0655970E 02	4.8766904E 02
104	4.5492065E 02	4.4287940E 02	4.4641883E 02.	4.3409442E 02
105	2.6623287E 02	2.5920228E 02	2.6280769E 02	2.5586172E 02
106	7.1312157E 02	6.9147973E 02	6.9660019E 02	6.7427474E 02
107	7.0400950E 02	6.8962449E 02	6.9388527E 02	6.7919820E 02
108	7.2260542E 02	7.1663372E 02	7.1887835E 02	7.1284214E 02
109	7.7732114E 02	7.5452999E 02	7.5943972E 02	7.3603631E 02
110	8.1978798E 02	8.0225683E 02	8.0792093E 02	7.9022744E 02
111	7.9236099E 02	7.8094802E 02	7.8629667E 02	7.7493370E 02
112	-1.5812000E 01	-1.5464000E 01	-1.5812000E 01	-1.5374000E 01
113	9.7658392E 02	9.4952910E 02	9.5452347E 02	9.2666159E 02
114	7.4054466E 02	7.2766416E 02	7.3512258E 02	7.1435671E 02
115	1.9577304E 02	1.7782712E 02	1.8994692E 02	1.7242627E 02
116	1.2252333E 03	1.1878441E 03	1.1953461E 03	1.1566606E 03
117	-5.8219759E 01	-5.5432628E 01	-5.2786074E 01	-4.9278355E 01
118	5.1444756E 02	4.9112341E 02	5.0179825E 02	4.7736750E 02
119	-3.1538713E 02	-3.0235288E 02	-3.2136056E 02	-3.0698248E 02
120	1.9659420E 03	1.8141998E 03	1.8850341E 03	1.7467346E 03
121	-1.7064437E 04	-1.6607418E 04	-1.7982217E 04	-1.7573250E 04
122	-2.3805785E 02	-2.5428169E 02	-2.3735538E 02	-2.5189947E 02
123	7.3484154E 02	7.0746918E 02	7.1150116E 02	6.8342859E 02
124	-1.2781035E 02	-1.3608036E 02	-1.3074072E 02	-1.3869974E 02
125	0.	0.	0.	0.
126	0.	0.	0.	0.
127	-9.9878212E 02	-1.0063251E 03	-1.0002081E 03	-1.0056823E 03
128	-1.4451852E 02	-1.4931234E 02	-1.4543695E 02	-1.5028336E 02
129	-2.8055711E 02	-2.8479345E 02	-2.8135309E 02	-2.8563711E 02
130	-3.4448909E 02	-3.4869878E 02	-3.4494717E 02	-3.4883284E 02
131	-2.6506462E 02	-2.6891873E 02	-2.6581867E 02	-2.6943477E 02

<i>S</i>	1.2170170E 04	1.1696473E 04	1.1866517E 04	1.1403584E 04
<i>M</i>	1.0282725E 06	9.9564216E 05	1.0065635E 06	9.7403697E 05
<i>T</i>	4.7531185E 05	4.5684912E 05	4.6023433E 05	4.4196812E 05
\bar{x}	2.5744452E 02	2.5744129E 02	2.5771572E 02	2.5774305E 02
\bar{y}	8.4491217E 01	8.5123283E 01	8.4823837E 01	8.5414982E 01
<i>AHM</i>	2.8350245E 03	2.8471613E 03	2.8428005E 03	2.8557255E 03
<i>FHM</i>	-4.7548603E 01	-2.0357181E 01	-4.7563095E 01	-7.4826931E 01
ΔS	2.5443071E 02	2.2892704E 02	2.3562378E 02	2.1027635E 02
ΔM	-1.5468000E 01	-1.5766500E 01	-1.5468000E 01	-1.5676500E 01
ΔT	6.0501417E 04	5.6808626E 04	5.7500893E 04	5.3691322E 04

Table 4.3 Wing Panel Point Loads, Symm. Flt., Flaps Retracted, Pt. B of V-n Diagram

P	F-5	F-6	F-7	F-5
100	-6.0459896E 00	-2.3318108E 00	-5.0649532E 00	-1.2678288E 00
101	-6.7162753E 01	-5.8378323E 01	-6.4725515E 01	-5.5596458E 01
102	-2.4275574E 02	-2.2665353E 02	-2.3873349E 02	-2.2221319E 02
103	-2.3736660E 02	-2.1908916E 02	-2.3234522E 02	-2.1345461E 02
104	1.3866104E 01	2.5907386E 01	1.6921131E 01	2.9245557E 01
105	1.3116649E 02	1.3819720E 02	1.3239731E 02	1.3934335E 02
106	-1.7507749E 02	-1.5343560E 02	-1.6914073E 02	-1.4681530E 02
107	1.8695895E 02	2.0134393E 02	1.9059696E 02	2.0528403E 02
108	5.4206839E 02	5.4803995E 02	5.4340764E 02	5.4944385E 02
109	-1.7271305E 02	-1.4992179E 02	-1.6628758E 02	-1.4288407E 02
110	2.5639822E 02	2.7392921E 02	2.6066247E 02	2.7835581E 02
111	5.3384283E 02	5.4525536E 02	5.3602192E 02	5.4738446E 02
112	3.9530000E 00	3.6050000E 00	3.9530000E 00	3.5150000E 00
113	-2.05222983E 02	-1.7817516E 02	-1.9730270E 02	-1.6944098E 02
114	1.7969453E 02	2.0057523E 02	1.8451766E 02	2.0528364E 02
115	9.6063906E 01	1.1401036E 02	9.8157605E 01	1.1567864E 02
116	-3.8963677E 02	-3.5224767E 02	-3.7889719E 02	-3.4021174E 02
117	3.4244593E 02	3.3965836E 02	3.4049347E 02	3.3698493E 02
118	-3.8326976E 02	-3.5994578E 02	-3.7872421E 02	-3.5429390E 02
119	1.3613970E 01	5.6016922E-01	1.5760309E 01	1.3827448E 00
120	1.2284586E 03	1.3802009E 03	1.2575318E 03	1.3958313E 03
121	-6.8506652E 04	-6.8963675E 04	-6.8176860E 04	-6.8585830E 04
122	1.8370671E 02	1.9993163E 02	1.8345384E 02	1.9799940E 02
123	-4.5729905E 02	-4.2992665E 02	-4.4891200E 02	-4.2083952E 02
124	-1.9068825E 02	-1.8241792E 02	-1.8963466E 02	-1.8167585E 02
125	-0.	-0.	-0.	-0.
126	-0.	-0.	-0.	-0.
127	-6.1871314E 02	-6.1117013E 02	-6.1820071E 02	-6.1272654E 02
128	-1.3090762E 02	-1.2611380E 02	-1.3057759E 02	-1.2573118E 02
129	-2.6726232E 02	-2.6302598E 02	-2.6697629E 02	-2.6269228E 02
130	-2.9535435E 02	-2.9114466E 02	-2.9518975E 02	-2.9130407E 02
131	-2.4769054E 02	-2.4383643E 02	-2.4741958E 02	-2.4380348E 02

S	1.1849923E 03	1.6586912E 03	1.2941069E 03	1.7570392E 03
M	9.1052876E 04	1.2368324E 05	9.8853748E 04	1.3138027E 05
T	-1.4227166E 05	-1.2380892E 05	-1.3685374E 05	-1.1858756E 05

\bar{x}	4.1656125E 02	3.7114253E 02	4.0225149E 02	3.6399283E 02
\bar{y}	7.6838369E 01	7.4566762E 01	7.6387622E 01	7.4773666E 01

AHM	3.3529131E 03	3.3407762E 03	3.3501189E 03	3.3371939E 03
FHM	-4.6656091E 02	-4.9375233E 02	-4.6655570E 02	-4.3929186E 02

ΔS	-6.1972384E 02	-5.9422154E 02	-6.1303797E 02	-5.8749145E 02
ΔM	3.8670000E 00	4.1654999E 00	3.8670000E 00	4.0755000E 00
ΔT	-9.9020634E 04	-9.5327846E 04	-9.7942435E 04	-9.4132859E 04

Table 4.4 Wing Panel Point Loads, Symm. Flt., Flaps Retracted, Pt. C of V-n Diagram

P	F-9	F-10	F-11	F-12
100	-4.0608690E 01	-3.3180381E 01	-3.8948097E 01	-3.1353857E 01
101	-1.4527413E 02	-1.2770540E 02	-1.4114864E 02	-1.2289055E 02
102	-3.2400430E 02	-2.9180008E 02	-3.1719585E 02	-2.8415532E 02
103	-3.6349610E 02	-3.2694146E 02	-3.5499644E 02	-3.1721528E 02
104	-1.0470605E 02	-8.0623642E 01	-9.9534814E 01	-7.4886000E 01
105	5.7135196E 01	7.1196534E 01	5.9218616E 01	7.3110681E 01
106	-3.5352987E 02	-3.1024640E 02	-3.4348074E 02	-2.9882996E 02
107	-2.7734463E 00	2.5996318E 01	3.3845680E 00	3.2758654E 01
108	3.3412897E 02	3.4607203E 02	3.3639588E 02	3.4846826E 02
109	-3.6791451E 02	-3.2233232E 02	-3.5703816E 02	-3.1023122E 02
110	3.4002642E 01	6.9064431E 01	4.1220726E 01	7.6607361E 01
111	3.0810958E 02	3.3093456E 02	3.1179812E 02	3.3452321E 02
112	7.9060000E 00	7.2100000E 00	7.9060000E 00	7.0300000E 00
113	-4.5091277E 02	-3.9680383E 02	-4.3749459E 02	-3.8177120E 02
114	-2.1327916E 01	2.0433185E 01	-1.3163823E 01	2.8368000E 01
115	4.1629810E 01	7.7522519E 01	4.5173855E 01	8.0215725E 01
116	-6.9289255E 02	-6.1811488E 02	-6.7471374E 02	-5.9734294E 02
117	3.4464250E 02	3.3906749E 02	3.4133743E 02	3.3432071E 02
118	-5.0230955E 02	-4.5566193E 02	-4.9461545E 02	-4.4575481E 02
119	9.4904224E 01	6.8796600E 01	9.8537455E 01	6.9782156E 01
120	6.7180948E 02	9.7529254E 02	7.2102155E 02	9.9762021E 02
121	-6.1496822E 04	-6.2410886E 04	-6.0938584E 04	-6.1756527E 04
122	2.3853601E 02	2.7098613E 02	2.3810837E 02	2.6719913E 02
123	-6.3075597E 02	-5.7601159E 02	-6.1655924E 02	-5.6041432E 02
124	-1.5034183E 02	-1.3380156E 02	-1.4855912E 02	-1.3264090E 02
125	-0.	-0.	-0.	-0.
126	-0.	-0.	-0.	-0.
127	-3.3624690E 02	-3.2116093E 02	-3.3537953E 02	-3.2443117E 02
128	-8.8476586E 01	-7.8888963E 01	-8.7917949E 01	-7.8225136E 01
129	-1.8439143E 02	-1.7591876E 02	-1.8390728E 02	-1.7533924E 02
130	-1.9483595E 02	-1.8641658E 02	-1.9455732E 02	-1.8678598E 02
131	-1.6957752E 02	-1.6186931E 02	-1.6911886E 02	-1.6188667E 02

S	-2.0180432E 03	-1.0706511E 03	-1.8333461E 03	-9.0748225E 02
M	-1.7922103E 05	-1.1396071E 05	-1.6601655E 05	-1.0096360E 05
T	-2.6026145E 05	-2.2333623E 05	-2.5109057E 05	-2.1455827E 05

Z	1.6753277E 02	8.7901483E 01	1.5954247E 02	6.0067527E 01
F	8.8809308E 01	1.0644057E 02	9.0553851E 01	1.1125683E 02

AHM	2.4908893E 03	2.4666157E 03	2.4861595E 03	2.4603096E 03
FHM	-4.3661643E 02	-4.9099927E 02	-4.3660761E 02	-3.8207994E 02

ΔS	-6.6240023E 02	-6.1139590E 02	-6.5108275E 02	-5.9999025E 02
ΔM	7.7340000E 00	8.3309999E 00	7.7340000E 00	8.1509999E 00
ΔT	-1.1098893E 05	-1.0360341E 05	-1.0916387E 05	-1.0154474E 05

Table 4.5 Wing Panel Point Loads, Symm. Flt., Flaps Retracted, Pt. D of V-n Diagram

<i>P</i>	<i>F-13</i>	<i>F-14</i>	<i>F-15</i>	<i>F-16</i>
100	5.0310909E 01	4.6335179E 01	4.8827672E 01	4.4869199E 01
101	2.2235310E 02	2.0937038E 02	2.1721059E 02	2.0369737E 02
102	4.3019711E 02	4.0067639E 02	4.1990129E 02	3.8946514E 02
103	4.6672062E 02	4.3808126E 02	4.5544407E 02	4.2589549E 02
104	3.1406070E 02	2.9223109E 02	3.0622216E 02	2.8386471E 02
105	2.3134688E 02	2.1052572E 02	2.2529767E 02	2.0416994E 02
106	6.8106341E 02	6.3950382E 02	6.6474109E 02	6.2179523E 02
107	4.0076670E 02	3.7278724E 02	3.9067952E 02	3.6205394E 02
108	1.4817798E 02	1.3609164E 02	1.4432593E 02	1.3204562E 02
109	7.5649977E 02	7.1117187E 02	7.3819390E 02	6.9154492E 02
110	4.4556090E 02	4.1089633E 02	4.3355190E 02	3.9846764E 02
111	2.4987668E 02	2.2490267E 02	2.4297713E 02	2.1779810E 02
112	-1.5812000E 01	-1.5116000E 01	-1.5812000E 01	-1.4936000E 01
113	9.7162822E 02	9.1618341E 02	9.4844809E 02	8.9114239E 02
114	4.6361185E 02	4.2151887E 02	4.4974278E 02	4.0771447E 02
115	8.8865840E 01	5.2813570E 01	8.3045601E 01	4.7595549E 01
116	1.2855143E 03	1.2113041E 03	1.2550557E 03	1.1780286E 03
117	-1.9612425E 02	-1.9776212E 02	-1.9349194E 02	-1.9391084E 02
118	8.1795768E 02	7.6566417E 02	8.0267931E 02	7.4784403E 02
119	-1.6845206E 02	-1.4775859E 02	-1.7679002E 02	-1.5370622E 02
120	6.9929385E 02	3.9093182E 02	6.1483752E 02	3.3198678E 02
121	3.0363035E 04	3.1905187E 04	2.9676881E 04	3.1139033E 04
122	-2.4769783E 02	-2.8533037E 02	-2.4909537E 02	-2.8355449E 02
123	1.0893828E 03	1.0268359E 03	1.0621349E 03	9.9778513E 02
124	1.2429244E 02	1.0369276E 02	1.1975521E 02	9.9490453E 01
125	0.	0.	0.	0.
126	0.	0.	0.	0.
127	-5.0029394E 02	-5.0420859E 02	-4.9730425E 02	-4.9658340E 02
128	-9.7727927E 01	-1.0225015E 02	-9.6566460E 01	-1.0104291E 02
129	-6.2800989E 01	-6.8299596E 01	-6.2431381E 01	-6.7897246E 01
130	8.0905986E 01	6.5991702E 01	7.8086746E 01	6.3314987E 01
131	1.0287593E 02	8.8781615E 01	9.9733226E 01	8.5665627E 01

<i>S</i>	9.3093953E 03	8.3355510E 03	8.9878825E 03	8.0311469E 03
<i>M</i>	7.4340269E 05	6.7873795E 05	7.2141167E 05	6.5674898E 05
<i>T</i>	5.0861090E 05	4.7096069E 05	4.9284132E 05	4.5542555E 05
\bar{Z}	2.4186585E 02	2.3999975E 02	2.4166602E 02	2.3979259E 02
\bar{Y}	7.9855099E 01	8.1426884E 01	8.0264919E 01	8.1775241E 01
<i>AHM</i>	-1.0988619E 03	-1.0377220E 03	-1.0776085E 03	-1.0119256E 03
<i>FHM</i>	9.1229973E 02	9.3378141E 02	8.9911271E 02	8.1022950E 02

Table 4.6 Wing Panel Point Loads, Symm. Flt., Flaps Retracted, Pt. A of V-n Diagram

<i>P</i>	<i>F-17</i>	<i>F-18</i>	<i>F-19</i>	<i>F-20</i>
100	-5.3483812E 01	-4.6623456E 01	-5.2295817E 01	-4.5217475E 01
101	-1.1994611E 02	-1.0601006E 02	-1.1729603E 02	-1.0275145E 02
102	-1.6522441E 02	-1.4061595E 02	-1.6102595E 02	-1.3590193E 02
103	-2.8150938E 02	-2.4785428E 02	-2.7522339E 02	-2.4024951E 02
104	-1.6528889E 02	-1.4252287E 02	-1.6133336E 02	-1.3796272E 02
105	-4.0911947E 01	-2.7575152E 01	-3.9191654E 01	-2.6158108E 01
106	-3.6893263E 02	-3.2428989E 02	-3.6051199E 02	-3.1423067E 02
107	-2.0831729E 02	-1.7940528E 02	-2.0327121E 02	-1.7363655E 02
108	-6.1555934E 01	-5.0687671E 01	-5.9884428E 01	-4.8921431E 01
109	-4.0684825E 02	-3.5839159E 02	-3.9745766E 02	-3.4742393E 02
110	-2.2040060E 02	-1.8582204E 02	-2.1458743E 02	-1.7959538E 02
111	-4.4888366E 01	-2.7922871E 01	-4.2840655E 01	-2.6322255E 01
112	7.9060000E 00	7.2100000E 00	7.9060000E 00	7.0300000E 00
113	-4.9283848E 02	-4.3638449E 02	-4.8142689E 02	-4.2302825E 02
114	-2.1751013E 02	-1.7668448E 02	-2.1098598E 02	-1.7032768E 02
115	5.2981511E 01	7.9255105E 01	5.4218580E 01	7.9092610E 01
116	-6.5470498E 02	-5.7889364E 02	-6.3966551E 02	-5.6090510E 02
117	7.3632439E 01	7.7706693E 01	7.2750143E 01	7.5805259E 01
118	-4.2807600E 02	-3.7365411E 02	-4.2031698E 02	-3.6317871E 02
119	6.4638062E 01	4.6033823E 01	6.9023184E 01	4.8199064E 01
120	-1.3232655E 02	1.5514116E 02	-9.4737228E 01	1.6552061E 02
121	-1.3415923E 04	-1.5127827E 04	-1.3110532E 04	-1.4756239E 04
122	1.0377014E 02	1.4345277E 02	1.0478137E 02	1.4145685E 02
123	-6.2559143E 02	-5.5451016E 02	-6.1098439E 02	-5.3740287E 02
124	-2.0256122E 01	-3.8359408E 00	-1.8733199E 01	-2.9882984E 00
125	-0.	-0.	-0.	-0.
126	-0.	-0.	-0.	-0.
127	2.4245415E 02	2.4710845E 02	2.4112350E 02	2.4120242E 02
128	8.2808663E 01	8.3882295E 01	8.1685256E 01	8.2431914E 01
129	2.9693410E 01	3.5359933E 01	2.9541322E 01	3.5188770E 01
130	6.9744479E 01	7.3548241E 01	6.9308871E 01	7.2064509E 01
131	3.0776462E 01	3.6595030E 01	3.0957968E 01	3.6075323E 01

<i>S</i>	-4.4056830E 03	-3.4528843E 03	-4.2530904E 03	-3.3190979E 03
<i>M</i>	-3.5402390E 05	-2.9086392E 05	-3.4359736E 05	-2.8056084E 05
<i>T</i>	-2.5996860E 05	-2.2154233E 05	-2.5219067E 05	-2.1393468E 05
\bar{x}	2.3749244E 02	2.3233847E 02	2.3720414E 02	2.3204433E 02
\bar{y}	8.0356188E 01	8.4237956E 01	8.0787693E 01	8.4529243E 01
<i>AHM</i>	-1.0199990E 02	-9.7519283E 01	-1.0166019E 02	-9.6374198E 01
<i>FHM</i>	-4.5952604E 02	-4.8049633E 02	-4.5304420E 02	-3.6360698E 02

Table 4.7 Wing Panel Point Loads, Symm. Flt., Flaps Retracted, Pt. E of V-n Diagram

<i>P</i>	<i>EF-1</i>	<i>INDUCED ELAS. DUE TO η_z</i>	<i>INDUCED ELAS. DUE TO $(\alpha=0)$</i>	<i>INDUCED ELAS. DUE TO α</i>
100	1.3326488E 02	1.3023940E 00	-8.7036248E 00	3.1799406E 00
101	3.0877227E 02	3.2356034E 00	-2.1622856E 01	7.9000875E 00
102	3.4505607E 02	5.3398259E 00	-3.5684932E 01	1.3037782E 01
103	5.0293675E 02	1.0647937E 01	-7.2813115E 01	2.7081565E 01
104	4.4421466E 02	6.4782331E 00	-4.4299691E 01	1.6476495E 01
105	2.6191974E 02	2.6099538E 00	-1.7847481E 01	6.6380588E 00
106	6.9433257E 02	1.1566905E 01	-7.8993739E 01	2.7963388E 01
107	6.9249570E 02	7.0881221E 00	-4.8406833E 01	1.7135777E 01
108	7.1836681E 02	2.6093384E 00	-1.7819926E 01	6.3081645E 00
109	7.6100354E 02	1.0958412E 01	-7.3844932E 01	2.4192455E 01
110	8.0895852E 02	7.2725342E 00	-4.9007080E 01	1.6055286E 01
111	7.8682652E 02	3.7163588E 00	-2.5043250E 01	8.2044586E 00
112	-1.5812000E 01	0.	-0.	0.
113	9.6060026E 02	1.2125317E 01	-8.1121149E 01	2.5406713E 01
114	7.3882012E 02	7.3774519E 00	-4.9356844E 01	1.5458301E 01
115	1.9155240E 02	3.2025361E 00	-2.1425700E 01	6.7104155E 00
116	1.2161505E 03	1.2997068E 01	-8.7371207E 01	2.7891504E 01
117	-5.6569459E 01	-2.3628691E 00	1.5884100E 01	-5.0706601E 00
118	5.0930135E 02	5.8391565E 00	-3.8967314E 01	1.2152255E 01
119	-3.1781707E 02	2.7571579E 00	-1.8399753E 01	5.7381039E 00
120	1.9802576E 03	2.4273314E 01	-1.6233924E 02	5.1135903E 01
121	-1.6884976E 04	2.7057511E 02	-1.8095987E 03	5.7001290E 02
122	-2.3777149E 02	-3.2484083E-01	2.1678088E 00	-6.7604777E-01
123	7.4700532E 02	4.7686315E 00	-3.1674132E 01	9.8619591E 00
124	-1.2628018E 02	5.9901107E-01	-3.9787423E 00	1.2388088E 00
125	0.			
126	0.			
127	-9.9699763E 02			
128	-1.4336921E 02			
129	-2.7956104E 02			
130	-3.4391591E 02			
131	-2.6412096E 02			

<i>S</i>	1.2047585E 04	1.4407755E 02	-9.7066959E 02	3.2402068E 02
<i>M</i>	1.0141437E 06	1.2002300E 04	-8.1095079E 04	2.7797873E 04
<i>T</i>	4.7115694E 05	6.5079607E 03	-4.3735501E 04	1.4205045E 04
<i>I</i>	2.5139200E 02	2.5133015E 02	2.5144296E 02	2.5266007E 02
<i>J</i>	8.4178170E 01	8.3304442E 01	8.3545502E 01	8.5790427E 01
<i>AH</i>	2.8252917E 03			
<i>FHM</i>	-4.7530464E 01			
ΔS	2.7771198E 02			
ΔM	-1.5468000E 01			
ΔT	6.4256177E 04			

Table 4.8 Wing Panel Point Loads, Symm. Flt., Flaps Retracted, Pt. B of V-n Diagram

LOCAL TWIST, deg.

Symbol	Contribution
o	Net
□	Basic, ($\alpha = a$)
△	Additional, (α)
▽	Inertia, (η_z)

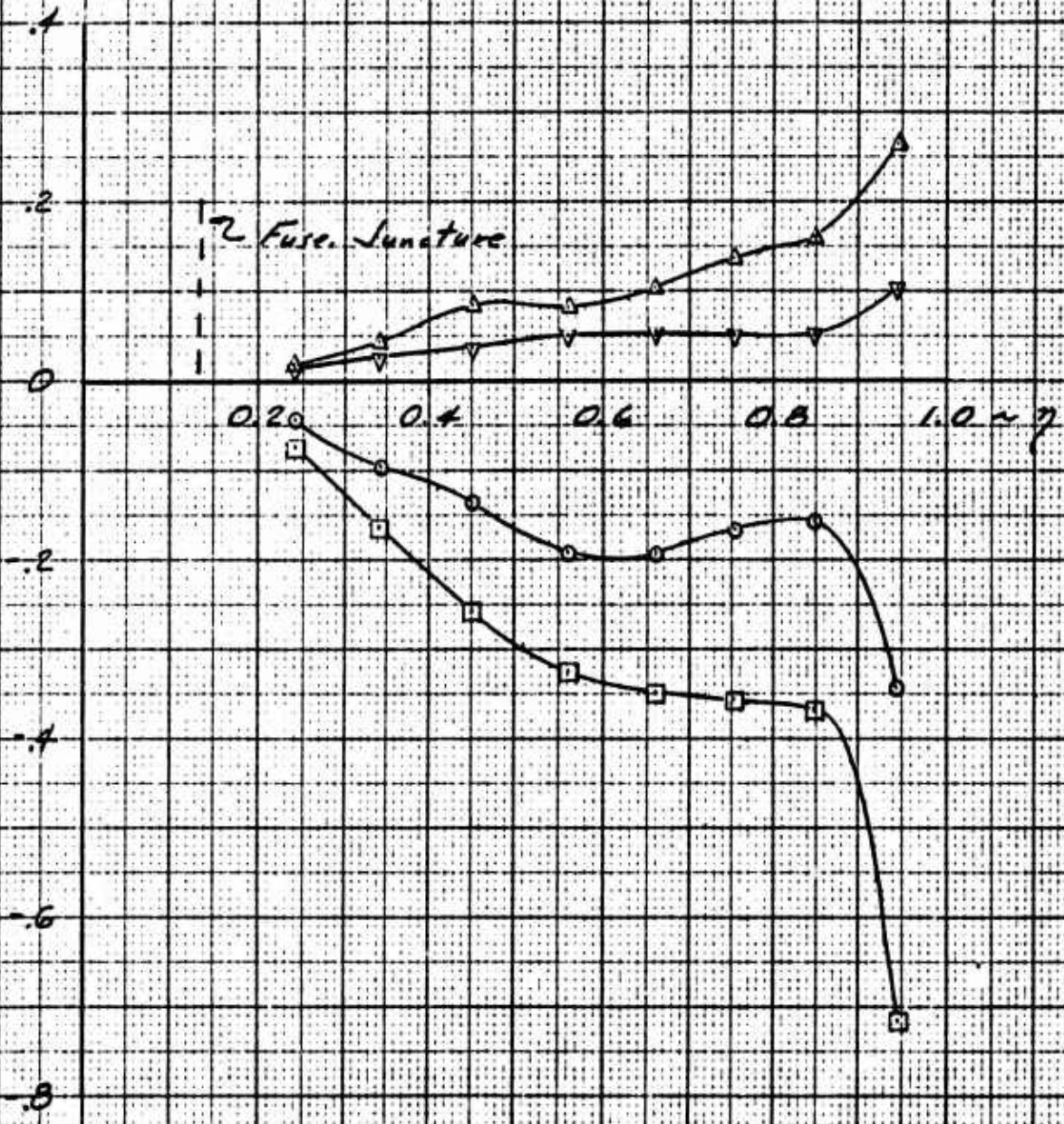

Figure 4.20 Wing Aeroelastic Twist Distribution, Condition EF-1

4.4.2 Symmetrical Flight, Flaps Extended

Rigid-body wing loads are presented in Tables 4.9 through 4.16 for points A, B, L and F of the flaps-extended, V-n diagram (Figure 3.1).

The results shown are in two parts (i. e. F-33A and F-33B). The first part corresponds to full flaps of 45° and the second part is the increment due to 15° of aileron droop.

The proper combinations of pitching acceleration and c. g. location follows the same sequence shown in Section 4.4.1.

<i>F</i>	<i>F-33A</i>	<i>F-33B</i>	<i>F-34A</i>	<i>F-34B</i>
100	3.4492541E 01	-1.1857400E 01	2.9435783E 01	-1.0513050E 01
101	1.1015270E 02	5.8380288E 00	9.7086244E 01	5.1761339E 00
102	1.9748472E 02	6.7054228E 01	1.6948049E 02	5.9451860E 01
103	2.1025032E 02	-2.0162588E 00	1.8392321E 02	-1.7876630E 00
104	1.3276629E 02	8.7767843E 00	1.1342963E 02	7.7817050E 00
105	8.3381656E 01	6.7594218E 01	6.5899510E 01	5.9930631E 01
106	2.3993597E 02	7.2577690E 00	2.0941213E 02	6.4349104E 00
107	1.7317338E 02	1.4519735E 01	1.4793932E 02	1.2873538E 01
108	1.2026479E 02	2.1781701E 01	1.0263349E 02	1.9312165E 01
109	2.2576690E 02	5.6448923E 00	1.9739451E 02	5.0048970E 00
110	2.1115648E 02	1.9295433E 01	1.7735452E 02	1.7107782E 01
111	2.8366323E 02	5.3921795E 01	2.3998414E 02	4.7808324E 01
112	-7.9060000E 00	0.	-7.2100000E 00	0.
113	3.4734029E 02	1.2674535E 01	3.0695938E 02	1.1237541E 01
114	2.3166894E 02	1.1591520E 01	1.8903800E 02	1.0277318E 01
115	4.8594429E 02	3.4722608E 01	3.9918582E 02	3.0785889E 01
116	6.1596899E 02	8.1606323E 00	5.4372534E 02	7.2354090E 00
117	-3.4751863E 00	-1.1545150E 01	-1.5846040E 01	-1.0236181E 01
118	3.4443182E 02	-1.3581753E 01	2.9899455E 02	-1.2041900E 01
119	-5.9355230E 01	-5.5137482E 00	-4.1797403E 01	-4.8886229E 00
120	3.7269590E 02	5.6992684E 01	5.8311386E 01	5.0531058E 01
121	8.3333406E 03	1.0599167E 02	1.0624864E 04	9.3974700E 01
122	-9.5602913E 00	2.5542568E 00	-6.0320361E 01	2.2646546E 00
123	5.7100681E 02	-2.4084285E 01	5.0453776E 02	-2.1353695E 01
124	1.5289785E 02	2.0840073E 01	1.2161113E 02	1.8477297E 01
125	0.	-0.	0.	-0.
126	0.	-0.	0.	-0.
127	-2.4632182E 02	-1.1599392E 01	-2.5047305E 02	-1.0284295E 01
128	1.8387499E 02	-1.9515635E 01	1.5286077E 02	-1.7303023E 01
129	2.4616506E 02	-4.5078914E 00	2.0919749E 02	-3.9968030E 00
130	9.5688815E 01	4.9697812E 01	7.4202297E 01	4.4063253E 01
131	3.8335263E 01	9.1545161E 01	2.5509231E 01	8.1166101E 01

<i>S</i>	5.0641471E 03	3.5062229E 02	4.0311624E 03	3.1086999E 02
<i>M</i>	3.8338573E 05	3.6303479E 04	3.1654049E 05	3.2187519E 04
<i>T</i>	2.1986997E 05	2.0604996E 03	1.8559543E 05	1.8268875E 03
\bar{z}	2.5308302E 02	2.9062331E 02	2.5045982E 02	2.9062331E 02
\bar{y}	7.5705884E 01	1.0354013E 02	7.8523377E 01	1.0354013E 02
<i>AHM</i>	-1.0767420E 03	-5.1369137E 02	-9.5404747E 02	-4.5545089E 02
<i>FHM</i>	-2.7370932E 03	-2.9164762E 01	-2.3533858E 03	-2.5858166E 01
ΔS	4.6145719E 02	1.3790131E-02	3.9699368E 02	1.2226105E-02
ΔM	-7.7340000E 00	0.	-8.3309999E 00	0.
ΔT	7.0624003E 04	-6.8390365E 01	6.2340662E 04	-6.0636497E 01

Table 4.9 Wing Panel Point Loads, Symm. Flt., Flaps Extended, Pt. A of V-n Diagram

P	F-35A	F-35B	F-36A	F-36B
100	3.3585986E 01	-1.1598460E 01	2.8437642E 01	-1.0185546E 01
101	1.0763640E 02	5.7105391E 00	9.3988731E 01	5.0148866E 00
102	1.9271302E 02	6.5589907E 01	1.6388099E 02	5.7599807E 01
103	2.0524932E 02	-1.9722278E 00	1.7796704E 02	-1.7319732E 00
104	1.2943720E 02	8.5851178E 00	1.0962717E 02	7.5392874E 00
105	8.1012009E 01	6.6118106E 01	6.3466632E 01	5.8063662E 01
106	2.3415701E 02	7.0992759E 00	2.0261250E 02	6.2344489E 00
107	1.6879737E 02	1.4202654E 01	1.4296857E 02	1.2472499E 01
108	1.1729171E 02	2.1306032E 01	9.9203634E 01	1.8710549E 01
109	2.2017467E 02	5.5216186E 00	1.9111391E 02	4.8489802E 00
110	2.0546888E 02	1.8874065E 01	1.7121049E 02	1.6574845E 01
111	2.7658847E 02	5.2744265E 01	2.3188983E 02	4.6319010E 01
112	-7.9060000E 00	0.	-7.0300000E 00	0.
113	3.3897913E 02	1.2397752E 01	2.9728963E 02	1.0887471E 01
114	2.2479328E 02	1.1338385E 01	1.8212682E 02	9.9571511E 00
115	4.7322125E 02	3.3964336E 01	3.8464564E 02	2.9826827E 01
116	6.0152358E 02	7.9824212E 00	5.2631976E 02	7.0100096E 00
117	-4.2548313E 00	-1.1293033E 01	-1.5948140E 01	-9.7173143E 00
118	3.3833444E 02	-1.3285153E 01	2.9055174E 02	-1.1666771E 01
119	-6.4007925E 01	-5.3933442E 00	-4.4303280E 01	-4.7363294E 00
120	3.3019833E 02	5.5748088E 01	4.0752349E 01	4.8956907E 01
121	8.1419127E 03	1.0267702E 02	1.0389379E 04	9.1047180E 01
122	-1.2768303E 01	2.4984651E 00	-6.1038301E 01	2.1941122E 00
123	5.5704297E 02	-2.3558337E 01	4.8825744E 02	-2.0688482E 01
124	1.4857171E 02	2.0385005E 01	1.1714023E 02	1.7901716E 01
125	0.	-0.	0.	-0.
126	0.	-0.	0.	-0.
127	-2.4489528E 02	-1.1346088E 01	-2.4442778E 02	-9.9639168E 00
128	1.7931056E 02	-1.9089456E 01	1.4705343E 02	-1.6763996E 01
129	2.4020349E 02	-4.4094489E 00	2.0174656E 02	-3.8722937E 00
130	9.2945714E 01	4.8612520E 01	7.1428838E 01	4.2690588E 01
131	3.6977130E 01	8.9546013E 01	2.4346493E 01	7.8637602E 01

S	4.8958396E 03	3.4296547E 02	3.8751310E 03	3.0118574E 02
M	3.7223405E 03	3.5510688E 04	3.0515361E 05	3.1184810E 04
T	2.1284769E 05	2.0155028E 03	1.7884955E 05	1.7699760E 03
\bar{z}	2.5302478E 02	2.9062331E 02	2.5034684E 02	2.9062331E 02
\bar{y}	7.6030686E 01	1.0354012E 02	7.8746655E 01	1.0354012E 02
AHM	-1.0539450E 03	-5.0247346E 02	-9.2445196E 02	-4.4126261E 02
FHM	-2.6736680E 03	-2.8527867E 01	-2.3820753E 03	-2.5052628E 01
ΔS	4.4953979E 02	1.3475418E-02	3.8403772E 02	1.1821747E-02
ΔM	-7.7340000E 00	0.	-8.1509999E 00	0.
ΔT	6.8947405E 04	-6.6896850E 01	6.0341939E 04	-5.8747543E 01

Table 4.10 Wing Panel Point Loads, Symm. Flt., Flaps Extended, Pt. A of V-n Diagram

<i>P</i>	<i>F-37A</i>	<i>F-37B</i>	<i>F-38A</i>	<i>F-38B</i>
100	-2.4252385E 00	-3.4451708E 01	-2.3801236E 00	-3.4451708E 01
101	6.8503598E 01	1.6962410E 01	6.8998106E 01	1.6962410E 01
102	2.0744212E 02	1.9482624E 02	2.0659802E 02	1.9482624E 02
103	1.0827332E 02	-5.8582445E 00	1.0911347E 02	-5.8582445E 00
104	8.0364923E 01	2.5500972E 01	7.9989183E 01	2.5500972E 01
105	1.4272371E 02	1.9639519E 02	1.4041358E 02	1.9639519E 02
106	1.4690323E 02	2.1087469E 01	1.4777625E 02	2.1087469E 01
107	1.1460265E 02	4.2187133E 01	1.1418114E 02	4.2187133E 01
108	9.6156068E 01	6.3286796E 01	9.5596538E 01	6.3286796E 01
109	1.2510588E 02	1.6401255E 01	1.2655351E 02	1.6401255E 01
110	1.7095104E 02	5.6062931E 01	1.6984250E 02	5.6062931E 01
111	4.1664990E 02	1.5666992E 02	4.1409469E 02	1.5666992E 02
112	-7.9060000E 00	0.	-7.5580000E 00	0.
113	2.2333382E 02	3.6825896E 01	2.2646783E 02	3.6825896E 01
114	2.1973913E 02	3.3679198E 01	2.1743331E 02	3.3679198E 01
115	1.2259375E 03	1.0088666E 02	1.2162884E 03	1.0088666E 02
116	5.4003856E 02	2.3710741E 01	5.4395143E 02	2.3710741E 01
117	1.9678719E 01	-3.3544344E 01	1.5601649E 01	-3.3544344E 01
118	2.3590914E 02	-3.9461731E 01	2.3023397E 02	-3.9461731E 01
119	-8.4514179E 01	-1.6020314E 01	-6.2838888E 01	-1.6020314E 01
120	6.8312361E 02	1.6559241E 02	6.4269821E 02	1.6559241E 02
121	-1.9955649E 03	3.0795910E 02	-3.0157523E 02	3.0795910E 02
122	4.8644489E 01	7.4211025E 00	3.2013744E 01	7.4211025E 00
123	4.1549948E 02	-6.9976963E 01	4.2112094E 02	-6.9976963E 01
124	2.4237257E 02	6.0551181E 01	2.3850465E 02	6.0551181E 01
125	0.	-0.	0.	-0.
126	0.	-0.	0.	-0.
127	-1.8310838E 02	-3.3702068E 01	-1.8924337E 02	-3.3702068E 01
128	5.8391911E 02	-5.6702736E 01	5.8030261E 02	-5.6702736E 01
129	7.5937235E 02	-1.3097691E 01	7.5615635E 02	-1.3097691E 01
130	3.3504443E 02	1.4439715E 02	3.3142194E 02	1.4439715E 02
131	1.5684087E 02	2.6598472E 02	1.5395336E 02	2.6598472E 02

<i>S</i>	5.4371179E 03	1.0187341E 03	5.3846939E 03	1.0187341E 03
<i>M</i>	3.9171686E 05	1.0547986E 05	3.8907352E 05	1.0547986E 05
<i>T</i>	1.6488579E 05	5.9867876E 03	1.6724471E 05	5.9867876E 03
<i>\bar{F}</i>	2.6617405E 02	2.9062331E 02	2.6544072E 02	2.9062331E 02
<i>\bar{J}</i>	7.2044945E 01	1.0354012E 02	7.2255456E 01	1.0354012E 02
<i>AHM</i>	-3.0659462E 03	-1.4925318E 03	-3.0637771E 03	-1.4925318E 03
<i>FHM</i>	-8.2713848E 03	-8.4738300E 01	-8.2441747E 03	-8.4738300E 01
ΔS	4.5293657E 02	3.9981842E-02	4.5363132E 02	3.9981842E-02
ΔM	-7.7340000E 00	0.	-8.0324999E 00	0.
ΔT	4.8989571E 04	-1.9870836E 02	4.9518836E 04	-1.9870836E 02

Table 4.11 Wing Panel Point Loads, Symm. Flt., Flaps Extended, Pt. B of V-n Diagram

<i>P</i>	<i>F-37A</i>	<i>F-39B</i>	<i>F-40A</i>	<i>F-40B</i>
100	-3.7431260E 00	-3.4451708E 01	-7.4048325E 00	-3.4451708E 01
101	6.5525208E 01	1.6962410E 01	5.7560724E 01	1.6962410E 01
102	2.0280823E 02	1.9482624E 02	1.8895497E 02	1.9482624E 02
103	1.0213498E 02	-5.8582445E 00	8.5638365E 01	-5.8582445E 00
104	7.6455302E 01	2.5500972E 01	6.5123961E 01	2.5500972E 01
105	1.4104280E 02	1.9639519E 02	1.3421674E 02	1.9639519E 02
106	1.4009292E 02	2.1087469E 01	1.2178129E 02	2.1087469E 01
107	1.0958101E 02	4.2187133E 01	9.5107762E 01	4.2187133E 01
108	9.2923008E 01	6.3286796E 01	8.3300729E 01	6.3286796E 01
109	1.1839434E 02	1.6401255E 01	1.0108073E 02	1.6401255E 01
110	1.6484405E 02	5.6062931E 01	1.4678995E 02	5.6062931E 01
111	4.1112747E 02	1.5666992E 02	3.9323587E 02	1.5666992E 02
112	-7.9060000E 00	0.	-7.4680000E 00	0.
113	2.1360123E 02	3.6825896E 01	1.8940724E 02	3.6825896E 01
114	2.1276240E 02	3.3679198E 01	1.9143464E 02	3.3679198E 01
115	1.2217166E 03	1.0088666E 02	1.2007951E 03	1.0088666E 02
116	5.2480033E 02	2.3710741E 01	4.8565153E 02	2.3710741E 01
117	1.9167359E 01	-3.3544344E 01	1.4072688E 01	-3.3544344E 01
118	2.2860550E 02	-3.9461731E 01	2.0171728E 02	-3.9461731E 01
119	-8.9430231E 01	-1.6020314E 01	-8.0097876E 01	-1.6020314E 01
120	6.4438167E 02	1.6559241E 02	5.1146681E 02	1.6559241E 02
121	-2.3037907E 03	3.0795910E 02	-1.4862888E 03	3.0795910E 02
122	4.6116025E 01	7.4211025E 00	2.3937961E 01	7.4211025E 00
123	3.9983551E 02	-6.9976963E 01	3.6142848E 02	-6.9976963E 01
124	2.3908908E 02	6.0551181E 01	2.2634892E 02	6.0551181E 01
125	0.	-0.	0.	-0.
126	0.	-0.	0.	-0.
127	-1.8096831E 02	-3.3702068E 01	-1.7887419E 02	-3.3702068E 01
128	5.8391911E 02	-5.6702736E 01	5.8029811E 02	-5.6702736E 01
129	7.5937235E 02	-1.3097691E 01	7.5615035E 02	-1.3097691E 01
130	3.3504443E 02	1.4439715E 02	3.3176993E 02	1.4439715E 02
131	1.5684057E 02	2.6598472E 02	1.5423086E 02	2.6598472E 02
<i>S</i>	5.2739191E 03	1.0187341E 03	4.7640808E 03	1.0187341E 03
<i>W</i>	3.8071683E 05	1.0547986E 05	3.4803396E 05	1.0547986E 05
<i>T</i>	1.5727229E 05	5.9867876E 03	1.3896710E 05	5.9867876E 03
<i>Z</i>	2.6667924E 02	2.9062331E 02	2.6745219E 02	2.9062331E 02
<i>J</i>	7.2188607E 01	1.0354012E 02	7.2748345E 01	1.0354012E 02
<i>ANA</i>	-3.0659462E 03	-1.4925318E 03	-3.0635962E 03	-1.4925318E 03
<i>ANB</i>	-8.2715848E 03	-8.4738300E 01	-8.2986293E 03	-8.4738300E 01
<i>L1</i>	4.4098247E 02	3.9981842E-02	4.0861375E 02	3.9981842E-02
<i>L2</i>	-7.7340000E 00	0.	-7.9424999E 00	0.
<i>L3</i>	4.7074825E 04	-1.9870836E 02	4.2199534E 04	-1.9870836E 02

Table 4.12 Wing Panel Point Loads, Symm. Flt., Flaps Extended, Pt. B of V-n Diagram

<i>F</i>	<i>F-41A</i>	<i>F-41B</i>	<i>F-42A</i>	<i>F-42B</i>
100	-2.8357937E 01	-3.4451708E 01	-2.4786518E 01	-3.4451708E 01
101	4.7516674E 00	1.6962410E 01	1.2399546E 01	1.6962410E 01
102	1.1481799E 02	1.9482624E 02	1.2833029E 02	1.9482624E 02
103	-1.8966949E 01	-5.8582445E 00	-3.0259616E 00	-5.8582445E 00
104	3.1892807E 00	2.5500972E 01	1.4253238E 01	2.5500972E 01
105	1.1787569E 02	1.9639519E 02	1.2478114E 02	1.9639519E 02
106	7.6754386E 00	2.1087469E 01	2.5420609E 01	2.1087469E 01
107	1.6445521E 01	4.2187133E 01	3.0995975E 01	4.2187133E 01
108	3.2143202E 01	6.3286796E 01	4.1541041E 01	6.3286796E 01
109	-9.1137424E 00	1.6401255E 01	7.7367738E 00	1.6401255E 01
110	5.9462894E 01	5.6062931E 01	7.7204189E 01	5.6062931E 01
111	3.1389123E 02	1.5666992E 02	3.3154381E 02	1.5666992E 02
112	-3.9530000E 00	0.	-4.3009999E 00	0.
113	2.4487000E 01	3.6825896E 01	4.1960112E 01	3.6825896E 01
114	1.0605199E 02	3.3679198E 01	1.2743099E 02	3.3679198E 01
115	1.1803311E 03	1.0088666E 02	1.2015194E 03	1.0088666E 02
116	2.2365692E 02	2.3710741E 01	2.6140122E 02	2.3710741E 01
117	2.7878861E 01	-3.3544344E 01	3.3254045E 01	-3.3544344E 01
118	4.0742142E 01	-3.9461731E 01	6.6384240E 01	-3.9461731E 01
119	-5.7719466E 01	-1.6020314E 01	-6.5955224E 01	-1.6020314E 01
120	6.0753831E 02	1.6559241E 02	7.5387729E 02	1.6559241E 02
121	-8.6393552E 03	3.0795910E 02	-9.4907087E 03	3.0795910E 02
122	7.0609919E 01	7.4211025E 00	9.4152803E 01	7.4211025E 00
123	1.0104209E 02	-6.9976963E 01	1.3824860E 02	-6.9976963E 01
124	1.9188563E 02	6.0551181E 01	2.0473004E 02	6.0551181E 01
125	0.	-0.	0.	-0.
126	0.	-0.	0.	-0.
127	-4.4979304E 01	-3.3702068E 01	-4.4694893E 01	-3.3702068E 01
128	5.9693711E 02	-5.6702736E 01	6.0055361E 02	-5.6702736E 01
129	7.7095435E 02	-1.3097691E 01	7.7417035E 02	-1.3097691E 01
130	3.5000643E 02	1.4439715E 02	3.5362894E 02	1.4439715E 02
131	1.6876886E 02	2.6598472E 02	1.7165637E 02	2.6598472E 02

<i>S</i>	3.1263659E 03	1.0187341E 03	3.6249462E 03	1.0187341E 03
<i>M</i>	2.1053121E 05	1.0547986E 05	2.4324654E 05	1.0547986E 05
<i>T</i>	4.5282444E 04	5.9867876E 03	6.4737481E 04	5.9867876E 03
\bar{F}	2.8169609E 02	2.9062331E 02	2.7864112E 02	2.9062331E 02
\bar{y}	6.7340553E 01	1.0354012E 02	6.7103490E 01	1.0354012E 02
<i>AH</i>	-3.0495502E 03	-1.4925318E 03	-3.0517072E 03	-1.4925318E 03
<i>FH</i>	-8.3550248E 03	-8.4738300E 01	-8.3822348E 03	-8.4738300E 01
ΔS	2.2901509E 02	3.9981842E-02	2.6100097E 02	3.9981842E-02
ΔM	-3.0070000E 00	0.	-3.5685000E 00	0.
ΔT	9.4491800E 03	-1.9870836E 02	1.4154501E 04	-1.9870836E 02

Table 4.13 Wing Panel Point Loads, Symm. Flt., Flaps Extended, Pt. F of V-n Diagram

P	F-43A	F-43B	F-44A	F-44E
100	-2.9004087E 01	-3.4451708E 01	-2.5351203E 01	-3.4451708E 01
101	3.2969048E 00	1.6962410E 01	1.1252782E 01	1.6962410E 01
102	1.1255458E 02	1.9482624E 02	1.2639445E 02	1.9482624E 02
103	-2.1965153E 01	-5.8582445E 00	-5.4862742E 00	-5.8582445E 00
104	1.2796659E 00	2.5500972E 01	1.2599705E 01	2.5500972E 01
105	1.1705466E 02	1.9639519E 02	1.2387586E 02	1.9639519E 02
106	4.3490119E 00	2.1087469E 01	2.2640954E 01	2.1087469E 01
107	1.3993059E 01	4.2187133E 01	2.8451806E 01	4.2187133E 01
108	3.0564106E 01	6.3286796E 01	4.0177157E 01	6.3286796E 01
109	-1.2391921E 01	1.6401255E 01	4.9022982E 00	1.6401255E 01
110	5.6475115E 01	5.6062931E 01	7.4511546E 01	5.6062931E 01
111	3.1119385E 02	1.5666992E 02	3.2906950E 02	1.5666992E 02
112	-3.2530000E 00	0.	-4.3910000E 00	0.
113	1.9733227E 01	3.6825896E 01	4.3899106E 01	3.6825896E 01
114	1.0264428E 02	3.3679198E 01	1.2395184E 02	3.3679198E 01
115	1.1782694E 03	1.0088666E 02	1.1991786E 03	1.0088666E 02
116	2.1621422E 02	2.3710741E 01	2.5531949E 02	2.3710741E 01
117	2.7529079E 01	-3.3544344E 01	3.2722418E 01	-3.3544344E 01
118	3.7174742E 01	-3.9461731E 01	6.4041848E 01	-3.9461731E 01
119	-6.0120639E 01	-1.6020314E 01	-6.9467181E 01	-1.6020314E 01
120	5.8861521E 02	1.6559241E 02	7.2141812E 02	1.6559241E 02
121	-8.7899050E 03	3.0795910E 02	-9.6082978E 03	3.0795910E 02
122	6.9374974E 01	7.4211025E 00	9.1545780E 01	7.4211025E 00
123	9.3390223E 01	-6.9976963E 01	1.3174999E 02	-6.9976963E 01
124	1.9028176E 02	6.0551181E 01	2.0301226E 02	6.0551181E 01
125	0.	-0.	0.	-0.
126	0.	-0.	0.	-0.
127	-4.3934009E 01	-3.3702068E 01	-4.6021948E 01	-3.3702068E 01
128	5.9693711E 02	-5.6702736E 01	6.0055811E 02	-5.6702736E 01
129	7.7095435E 02	-1.3097691E 01	7.7417635E 02	-1.3097691E 01
130	3.5000640E 02	1.4439715E 02	3.5328093E 02	1.4439715E 02
131	1.6876886E 02	2.6598472E 02	1.7137887E 02	2.6598472E 02

S	3.0466531E 03	1.0187341E 03	3.5350198E 03	1.0187341E 03
M	2.0515838E 05	1.0547986E 05	2.3730952E 05	1.0547986E 05
T	4.2563710E 04	5.9867876E 03	6.0846896E 04	5.9867876E 03
\bar{T}	2.8252236E 02	2.9062331E 02	2.7929226E 02	2.9062331E 02
\bar{Y}	6.7328936E 01	1.0354012E 02	6.7253445E 01	1.0354012E 02
AAH	-3.0495382E 03	-1.4925318E 03	-3.0520881E 03	-1.4925318E 03
FAA	-8.3550248E 03	-8.4738300E 01	-8.3277804E 03	-8.4738300E 01
L S	2.2317625E 02	3.9981842E-02	2.5551047E 02	3.9981842E-02
L M	-3.8670000E 00	0.	-3.6585000E 00	0.
L T	3.5139475E 03	-1.9870835E 02	1.3333706E 04	-1.9870835E 02

Table 4.14 Wing Panel Point Loads, Symm. Flt., Flaps Extended, Pt. F of V-n Diagram

P	F-45A	F-45B	F-46A	F-46B
100	8.0786170E 00	-1.1598460E 01	1.5217409E 01	-1.1598460E 01
101	4.4842071E 01	5.7105391E 00	5.0128717E 01	5.7105391E 00
102	1.0157873E 02	6.5589907E 01	1.2858923E 02	6.5589907E 01
103	7.9982623E 01	-1.9722278E 00	1.1184578E 02	-1.9722278E 00
104	5.3518581E 01	8.5851178E 00	7.5634537E 01	8.5851178E 00
105	5.6704466E 01	6.6118106E 01	7.0510219E 01	6.6118106E 01
106	9.7118864E 01	7.0992759E 00	1.3258837E 02	7.0992759E 00
107	7.2255042E 01	1.4202654E 01	1.0053918E 02	1.4202654E 01
108	5.4318216E 01	2.1306032E 01	7.3103979E 01	2.1306032E 01
109	8.8112916E 01	5.5216186E 00	1.2189341E 02	5.5216186E 00
110	9.5937462E 01	1.8874065E 01	1.5160135E 02	1.8874065E 01
111	1.7560540E 02	5.2744265E 01	2.1089368E 02	5.2744265E 01
112	-3.9530000E 00	0.	-4.6489999E 00	0.
113	1.4326149E 02	1.2397752E 01	1.9017797E 02	1.2397752E 01
114	1.1334926E 02	1.1338385E 01	1.5608588E 02	1.1338385E 01
115	4.2897183E 02	3.3964336E 01	4.7133560E 02	3.3964336E 01
116	2.9004112E 02	7.9824212E 00	3.6548311E 02	7.9824212E 00
117	4.1097722E 00	-1.1293033E 01	1.5058741E 01	-1.1293033E 01
118	1.4551568E 02	-1.3285153E 01	1.9677758E 02	-1.3285153E 01
119	-3.5632627E 01	-5.3933442E 00	-5.2119240E 01	-5.3933442E 00
120	2.6706914E 02	5.5748088E 01	5.5962861E 02	5.5748088E 01
121	1.5972218E 03	1.0367702E 02	-1.0642804E 02	1.0367702E 02
122	1.0010056E 01	2.4984651E 00	5.7087934E 01	2.4984651E 00
123	2.4762242E 02	-2.3558337E 01	3.2198747E 02	-2.3558337E 01
124	9.9140664E 01	2.0385005E 01	1.2481976E 02	2.0385005E 01
125	0.	-0.	0.	-0.
126	0.	-0.	0.	-0.
127	-1.0745423E 02	-1.1346088E 01	-1.0687888E 02	-1.1346088E 01
128	1.9232856E 02	-1.9089456E 01	1.9956156E 02	-1.9089456E 01
129	2.5186549E 02	-4.4094489E 00	2.5829749E 02	-4.4094489E 00
130	1.0790771E 02	4.8612520E 01	1.1515271E 02	4.8612520E 01
131	4.8905129E 01	8.9546013E 01	5.4680130E 01	8.9546013E 01

S	2.6375587E 03	3.4296547E 02	3.6342202E 03	3.4296547E 02
M	1.9458506E 05	3.5510688E 04	2.5998208E 05	3.5510688E 04
T	9.6692208E 04	2.0155028E 03	1.3357899E 05	2.0155028E 03
\bar{Z}	2.5984026E 02	2.9062331E 02	2.5974411E 02	2.9062331E 02
\bar{Y}	7.3774683E 01	1.0354012E 02	7.1537240E 01	1.0354012E 02
AHM	-1.0375370E 03	-5.0247346E 02	-1.0418750E 03	-5.0247346E 02
FHM	-2.7573080E 03	-2.8527867E 01	-2.8117280E 03	-2.8527867E 01
ΔS	2.2946151E 02	1.3475418E-02	2.9339649E 02	1.3475418E-02
ΔM	-3.8670000E 00	0.	-3.2700000E 00	0.
ΔT	3.0022642E 04	-6.6396850E 01	3.9427418E 04	-6.6896850E 01

Table 4.15 Wing Panel Point Loads, Symm. Flt., Flaps Extended, Pt. L of V-n Diagram

<i>P</i>	<i>F-47A</i>	<i>F-47B</i>	<i>F-48A</i>	<i>F-48B</i>
100	7.3713165E 00	-1.1598460E 01	1.4688321E 01	-1.1598460E 01
101	4.3249633E 01	5.7105391E 00	5.9186686E 01	5.7105391E 00
102	9.9101152E 01	6.5589907E 01	1.2682025E 02	6.5589907E 01
103	7.6700680E 01	-1.9722278E 00	1.0971057E 02	-1.9722278E 00
104	5.1428242E 01	8.5851178E 00	7.4101531E 01	8.5851178E 00
105	5.5805733E 01	6.6118106E 01	6.9462420E 01	6.6118106E 01
106	9.2477634E 01	7.0992759E 00	1.3011937E 02	7.0992759E 00
107	6.9570155E 01	1.4202654E 01	9.8530306E 01	1.4202654E 01
108	5.2589673E 01	2.1306032E 01	7.1843243E 01	2.1306032E 01
109	8.4524493E 01	5.5216186E 00	1.1915995E 02	5.5216186E 00
110	9.2666928E 01	1.8874065E 01	1.2879172E 02	1.8874065E 01
111	1.7255276E 02	5.2744265E 01	2.0345038E 02	5.2744265E 01
112	-2.9530000E 00	0.	-4.8289999E 00	0.
113	1.2805784E 02	1.2397752E 01	1.8647227E 02	1.2397752E 01
114	1.0961904E 02	1.1338385E 01	1.5229344E 02	1.1338385E 01
115	4.2671505E 02	2.3964326E 01	4.6856942E 02	2.3964326E 01
116	2.8189408E 02	7.9824212E 00	3.6023401E 02	7.9824212E 00
117	3.8363557E 00	-1.1293033E 01	1.4027511E 01	-1.1293033E 01
118	1.4161066E 02	-1.3285153E 01	1.9540700E 02	-1.3285153E 01
119	-3.8261040E 01	-5.3933442E 00	-5.6912421E 01	-5.3933442E 00
120	2.4635522E 02	5.5748088E 01	5.1229011E 02	5.5748088E 01
121	1.4324244E 03	1.0367702E 02	-2.0174347E 02	1.0367702E 02
122	0.6582537E 00	2.4984651E 00	5.3021148E 01	2.4984651E 00
123	2.3924639E 02	-2.3558337E 01	3.1609396E 02	-2.3558337E 01
124	2.7384996E 01	2.0385005E 01	1.2287426E 02	2.0385005E 01
125	0.	-0.	0.	-0.
126	0.	-0.	0.	-0.
127	-1.0681002E 02	-1.1346088E 01	-1.1050407E 02	-1.1346088E 01
128	1.9232856E 02	-1.9089456E 01	1.9957056E 02	-1.9089456E 01
129	2.5186549E 02	-4.4094489E 00	2.5630949E 02	-4.4094489E 00
130	1.0790771E 02	4.8612520E 01	1.1445671E 02	4.8612520E 01
131	4.8905129E 01	8.9546012E 01	5.4125130E 01	8.9546012E 01
<i>S</i>	2.5503021E 03	3.4296547E 02	3.5304218E 03	3.4296547E 02
<i>M</i>	1.8870373E 03	3.5510688E 04	2.5409943E 05	3.5510688E 04
<i>T</i>	2.2621541E 04	2.0155028E 03	1.2925258E 05	2.0155028E 03
<i>Z</i>	2.6018213E 02	2.9062331E 02	2.5988891E 02	2.9062331E 02
<i>Y</i>	7.3992709E 01	1.0354012E 02	7.1974254E 01	1.0354012E 02
<i>AAH</i>	-1.0375370E 03	-5.0247346E 02	-1.0426370E 03	-5.0247346E 02
<i>FHH</i>	-2.7573080E 03	-2.8527867E 01	-2.7028190E 03	-2.8527867E 01
<i>ΔC</i>	2.2307014E 02	1.3475418E-02	2.8783904E 02	1.3475418E-02
<i>ΔM</i>	-3.8670000E 00	0.	-3.4500000E 00	0.
<i>ΔT</i>	2.8998896E 04	-6.6896850E 01	3.3754682E 04	-6.6896850E 01

Table 4.16 Wing Panel Point Loads, Symm. Flt., Flaps Extended, Pt. L of V-n Diagram

4.4.3 Unsymmetrical Flight, Flaps Retracted

Wing loads developed during a rolling pull-out maneuver are presented in two parts: Symmetrical contribution and antisymmetrical contribution.

The symmetrical contribution assumed a rigid wing and considered vertical load factors, n_z , from 1.0 to 3.0. These are shown in Table 4.17 for designations RP-1 through RP-4 which correspond, respectively, to $n_z = 3.0, 2.5, 2.0$ and 1.0 .

Various antisymmetrical contributions are presented in Table 4.18 for an elastic wing with specific combinations of roll rate, roll acceleration and aileron deflection. The undeflected aileron case is presented, among other data, in Table 4.19. Upon superposition of all possible combinations, the rear-spar fuselage joint slightly exceeded its allowable loading for $n_z = 3.0$ and $\delta_a = 15^\circ$. Consequently, the maneuver was placarded to $n_z = 2.5$.

P	RP-1	RP-2	RP-3	RP-4
100	1.0669534E 02	9.2703688E 01	7.8712033E 01	5.0695080E 01
101	2.3679665E 02	1.9905267E 02	1.6130866E 02	8.5737158E 01
102	2.3279357E 02	1.7376405E 02	1.1473452E 02	-3.4624301E 00
103	3.7227412E 02	2.7658606E 02	2.2089798E 02	6.9349649E 01
104	3.6872995E 02	3.2468653E 02	2.8064309E 02	1.9245150E 02
105	2.4003358E 02	2.2655192E 02	2.1307024E 02	1.8606474E 02
106	5.3940757E 02	4.5070824E 02	3.6200885E 02	1.8440655E 02
107	6.0300503E 02	5.5137388E 02	4.9974268E 02	3.9635558E 02
108	6.8738349E 02	6.6935700E 02	6.5133051E 02	6.1523159E 02
109	5.9156330E 02	4.9669036E 02	4.0181738E 02	2.1185118E 02
110	7.0992978E 02	6.5367733E 02	5.9742506E 02	4.8477398E 02
111	7.4209815E 02	7.1629045E 02	6.9048314E 02	6.3879311E 02
112	-1.1859000E 01	-9.8824999E 00	-7.9060000E 00	-3.9530000E 00
113	7.4546301E 02	6.2744261E 02	5.0942226E 02	2.7310952E 02
114	6.3796428E 02	5.8117714E 02	5.2438985E 02	4.1065047E 02
115	1.7721639E 02	1.6728783E 02	1.5735893E 02	1.3743075E 02
116	9.0936078E 02	7.4809191E 02	5.8682304E 02	2.6391692E 02
117	2.0620898E 01	6.0649451E 01	1.0067622E 02	1.8079660E 02
118	3.3790970E 02	2.4823085E 02	1.5855102E 02	-2.0963745E 01
119	-2.4816706E 02	-2.1522406E 02	-1.8228007E 02	-1.1646629E 02
120	1.8376705E 03	1.7645126E 03	1.6913545E 03	1.5440415E 03
121	-2.7134804E 04	-3.2272331E 04	-3.7409855E 04	-4.7696211E 04
122	-1.5387084E 02	-1.1170143E 02	-6.9529169E 01	1.4822154E 01
123	5.0195940E 02	3.8291565E 02	2.8387192E 02	2.5496781E 01
124	-1.5968867E 02	-1.4595513E 02	-1.5222152E 02	-1.6479080E 02
125	0.	0.	0.	0.
126	0.	0.	0.	0.
127	-9.2242942E 02	-8.8441216E 02	-8.4639435E 02	-7.7037777E 02
128	-1.4157810E 02	-1.4021031E 02	-1.3384252E 02	-1.3611825E 02
129	-2.7770901E 02	-2.7637572E 02	-2.7503844E 02	-2.7237767E 02
130	-3.3457332E 02	-3.2963650E 02	-3.2471969E 02	-3.1489169E 02
131	-2.6141061E 02	-2.5966770E 02	-2.5752479E 02	-2.5444827E 02

<i>S</i>	1.0045290E 04	8.9489866E 03	7.8526849E 03	5.6563385E 03
<i>M</i>	8.4598705E 05	7.5242347E 05	6.5885991E 05	4.7146530E 05
<i>T</i>	3.5557784E 05	2.9572950E 05	2.3208116E 05	1.0859869E 05
\bar{z}	2.6112244E 02	2.5367734E 02	2.6694563E 02	2.7730053E 02
\bar{y}	5.4217285E 01	5.4079180E 01	5.3902501E 01	5.3351675E 01
<i>AHM</i>	2.9367525E 03	2.9884852E 03	3.0402175E 03	3.1437780E 03
<i>F.M</i>	-1.5134762E 02	-1.7524874E 02	-2.1514987E 02	-2.9895230E 02
ΔS	8.4019794E 01	-3.2589149E 00	-9.0539334E 01	-2.6532740E 02
ΔM	-1.1601000E 01	-9.6674999E 00	-7.7340000E 00	-3.8670000E 00
ΔT	2.9309982E 04	1.3379682E 04	-2.5506424E 03	-3.4448225E 04

Table 4.17 Wing Panel Point Loads, Symm. Contributions, Flaps Retracted

P	A. S. INCR., INCL: $\phi, \dot{\phi}, \ddot{\phi}, \delta_A = 7.05^\circ$	A. S. INCR., INCL: $\phi, \dot{\phi}, \ddot{\phi}, \delta_A = -8.94^\circ$	A. S. INCR., INCL: $\phi, \dot{\phi}, \ddot{\phi}, \delta_A = 15^\circ$	A. S. INCR., INCL: $\phi, \dot{\phi}, \ddot{\phi}, \delta_A = -19^\circ$
100	-1.0137494E 02	1.2771173E 02	-2.6010187E 02	3.1599500E 02
101	7.9442432E 01	-8.5524454E 01	-9.0799209E 01	7.7891660E 01
102	5.1495504E 02	-6.4132797E 02	7.6732531E 02	-1.0355197E 03
103	1.6890587E 01	3.9929829E 00	-4.6574680E 02	5.1006685E 02
104	5.7188902E 01	-6.4750955E 01	-1.3435421E 02	1.1930567E 02
105	4.4468294E 02	-5.7751551E 02	9.5838056E 02	-1.2402839E 03
106	1.0575919E 02	-1.0370455E 02	-3.9753142E 02	4.0189189E 02
107	9.9544494E 01	-1.1869235E 02	-7.7840953E 01	3.7204447E 01
108	1.4388849E 02	-1.8425885E 02	2.4358200E 02	-3.2921548E 02
109	9.6440210E 01	-9.3089528E 01	-4.2963931E 02	4.3675028E 02
110	8.3734498E 01	-1.1501450E 02	-1.4021168E 00	-6.0737200E 01
111	3.2070173E 02	-4.2493566E 02	7.6222636E 02	-9.8343633E 02
112	-2.1023991E 01	2.1023991E 01	-7.2042442E-01	7.2042442E-01
113	1.5014946E 02	-1.6063935E 02	-3.0680130E 02	2.8453919E 02
114	-5.4794259E 01	4.0550930E 01	-1.0391752E 02	7.3689642E 01
115	3.4180796E 01	-1.0051903E 02	4.7219923E 02	-6.1298543E 02
116	1.4215278E 02	-1.4400483E 02	-4.2124203E 02	4.1731151E 02
117	-1.0749485E 02	2.2821693E 02	-6.8319286E 01	1.1229677E 02
118	5.6730478E 01	-6.3633144E 01	-4.2414584E 02	4.9438672E 02
119	-4.9799277E 02	5.1179872E 02	-1.9173568E 02	2.2103506E 02
120	-2.4349258E 03	2.3431863E 03	-3.3647025E 02	1.4177662E 02
121	4.1968505E 03	-4.1470633E 03	-1.0687586E 04	1.0793247E 04
122	-2.5700182E 02	2.5151637E 02	6.9311724E 01	-8.0953841E 01
123	-1.6080766E 02	2.1299258E 02	-6.3219022E 02	7.4293945E 02
124	9.7155008E 01	-1.3895255E 02	3.6366295E 02	-4.5236693E 02
125	0.	-0.	0.	-0.
126	0.	-0.	0.	-0.
127	2.2702436E 02	-2.0352328E 02	-7.8901005E 01	1.2877609E 02
128	-1.7606710E 02	2.1560698E 02	-3.2370566E 02	4.0761901E 02
129	-7.9956589E 01	8.9089857E 01	-8.4298358E 01	1.0368140E 02
130	2.8878392E 02	-3.8947467E 02	7.8782064E 02	-1.0015113E 03
131	6.0120185E 02	-7.8667808E 02	1.4558777E 03	-1.8495038E 03

S	-1.2518191E 03	7.2644736E 02	-7.0627031E 02	-4.0869759E 02
M	1.1226568E 05	-1.6901981E 05	5.0753111E 04	-1.7119934E 05
T	-1.0703828E 05	1.1049318E 05	-2.5518898E 05	2.6252114E 05
\bar{x}	2.1099381E 02	1.4439926E 02	-6.4819145E 01	9.3883592E 02
\bar{y}	-8.9682031E 01	-2.3266626E 02	-7.1860745E 01	4.1889000E 02
AHM	-4.0799000E 03	5.1206704E 03	-8.1139911E 03	1.0322762E 04
FHM	5.5202842E 01	3.8867645E 00	-4.6650237E 02	5.9190504E 02
ΔS	-1.9106807E 01	1.9078655E 01	-9.4959035E 01	9.4899373E 01
ΔM	-3.1788781E 01	3.1788781E 01	-1.0892990E 00	1.0892990E 00
ΔT	3.4662504E 03	-3.3276874E 03	-1.7813403E 04	1.8107469E 04

Table 4.18 Wing Panel Point Loads, Antisymm. Contribution, Flaps Retracted

4.4.4 Unsymmetrical Flight, Flaps Extended

A rigid wing was assumed for both symmetrical and antisymmetrical loads. The full-flap (45°), 1 g symmetrical contribution is presented as A and B parts in Table 4.19, the latter of which is the drooped aileron contribution. Roll damping and roll acceleration increment ($\delta_A = 0$) is also shown therein as one of five antisymmetrical contributions. The remaining antisymmetrical contributions are presented in Table 4.20. None of the above cases were found critical.

4.4.5 Unit Inertial Loads

Unit inertial panel point loads are presented in Table 4.21. Residual fuselage reactions associated with these data are shown in Table 4.32.

4.4.6 Unit Aerodynamic Loads

Unit aerodynamic panel point loads are presented in Tables 4.23 through 4.26. Although these, as shown, are unadulterated, certain scale factors were applied such that a reasonable agreement with total aerodynamic data was realized. In particular, basic and additional angle of attack loadings were multiplied by a scale factor "K" and basic loading ($\alpha = 0$) was treated displaced by an incremental angle, $\Delta\alpha$. For example,

$$1. (\text{Pt. Load})_{\text{corr.}} = K (\text{Pt. Load})_{\text{uncorr.}}$$

$$2. (\alpha)_{\text{corr.}} = (\alpha)_{\text{uncorr.}} + \Delta\alpha$$

where . . .

	<u>(M = .285)$\delta_F = 0$</u>	<u>(M = .285)$\delta_F = 45^\circ$</u>	<u>M = .8</u>	<u>M = .9</u>
K	1.0653	1.1063	0.8870	0.9719
$\Delta\alpha$	-2.203	-3.435	1.0534	-0.4530

Roll damping and incremental aileron loadings were similarly corrected. However, the distribution of aileron loading, derived from M = .285 pressure data was applied at all evaluated conditions.

<i>P</i>	<i>RP-5A</i>	<i>KP-5B</i>	<i>A.S. INCREMENT, FLAPS-UP, $\delta_A = 0$</i>	<i>A.S. INCREMENT, FLAPS-DN, $\delta_A = 0$</i>
100	-2.8774684E 01	-3.4451708E 01	1.7769674E 01	7.3118881E 00
101	3.8133886E 00	1.6962410E 01	1.0346520E 02	3.3522603E 01
102	1.1335814E 02	1.9482624E 02	1.3041655E 02	3.9353582E 01
103	-2.0900702E 01	-5.8582445E 00	1.0987671E 02	6.3729501E 01
104	1.9576358E 00	2.5500972E 01	1.0196416E 02	3.2616703E 01
105	1.1734615E 02	1.9639519E 02	-5.2330523E 00	-3.5426626E 00
106	5.5299917E 00	2.1087469E 01	2.4796526E 02	6.8057947E 01
107	1.4863862E 01	4.2187133E 01	1.1531935E 02	3.7371065E 01
108	3.1124731E 01	6.3286796E 01	2.4812663E 01	1.9950079E 01
109	-1.1228071E 01	1.6401255E 01	2.5286365E 02	5.7043238E 01
110	5.7535865E 01	5.6062931E 01	7.1464319E 01	2.3569533E 01
111	3.1215150E 02	1.5666992E 02	-3.2087631E 01	1.3510139E 01
112	-3.9530000E 00	0.	-1.7522896E 01	-5.5164027E 00
113	2.1420957E 01	3.6825896E 01	2.4941150E 02	6.6450466E 01
114	1.0385411E 02	3.3679198E 01	-5.0312862E 00	-9.4545317E-01
115	1.1790013E 03	1.0088666E 02	-1.5922646E 02	-4.0521677E 01
116	2.1885660E 02	2.3710741E 01	2.8823749E 02	8.8293600E 01
117	2.7717765E 01	-3.3544344E 01	-1.4853653E 02	-3.0900951E 01
118	3.8441279E 01	-3.9461731E 01	2.5094905E 02	7.9834030E 01
119	-5.9268155E 01	-1.6020314E 01	-3.4546258E 02	-1.0287700E 02
120	5.9533347E 02	1.6559241E 02	-1.9287219E 03	-6.3657358E 02
121	-8.7364554E 03	3.0795910E 02	7.8131160E 03	1.3744425E 03
122	6.9813405E 01	7.4211025E 00	-2.4533032E 02	-6.6308258E 01
123	9.6106863E 01	-6.9976963E 01	1.1568330E 02	4.4678339E 01
124	1.9085119E 02	6.0551181E 01	-6.2617011E 01	-1.3556025E 01
125	0.	-0.	0.	0.
126	0.	-0.	0.	0.
127	-4.4305120E 01	-3.3702068E 01	2.2377306E 02	6.3768368E 01
128	5.9693711E 02	-5.6702736E 01	-2.0152214E 01	-8.1585274E 00
129	7.7095435E 02	-1.3097691E 01	-3.4140860E 01	-1.3006108E 01
130	3.5000643E 02	1.4439715E 02	-6.9319037E 01	-2.4182627E 01
131	1.6876886E 02	2.6598472E 02	-7.0889618E 01	-2.6144874E 01

<i>S</i>	3.0749535E 03	1.0187341E 03	-7.7957081E 02	-2.2544930E 02
<i>M</i>	2.0706520E 05	1.0547986E 05	7.4829694E 04	2.4629823E 04
<i>T</i>	4.3883972E 04	5.9867876E 03	1.0993269E 04	-1.8880743E 02

\bar{x}	2.8222857E 02	2.9062331E 02	3.1060169E 02	2.9566253E 02
\bar{y}	6.7339520E 01	1.0354012E 02	-9.5988321E 01	-1.0924772E 02

<i>AHM</i>	-3.0495382E 03	-1.4925318E 03	-2.2266558E 02	-3.0710554E 01
<i>FHM</i>	-8.3550248E 03	-8.4738300E 01	2.3266902E 02	7.1961970E 01

ΔS	2.2524921E 02	3.9981842E-02	2.1645279E 01	1.2511278E 01
ΔM	-3.8670000E 00	0.	-2.6495039E 01	-8.3409334E 00
ΔT	8.8459849E 03	-1.9870836E 02	1.0033143E 04	4.0623688E 03

Table 4.19 Wing Panel Point Loads, Symm. Contrib. (Flaps-dn.) Plus Antisymm. Increments ($\delta_A = 0$)

<i>P</i>	<i>A.S. INCR., INCL:</i> $\phi, \ddot{\phi}, \dot{\xi} \delta_A = 9.6^\circ$	<i>A.S. INCR., INCL:</i> $\phi, \ddot{\phi}, \dot{\xi} \delta_A = -18.4^\circ$	<i>A.S. INCR., INCL:</i> $\phi, \ddot{\phi}, \dot{\xi} \delta_A = 12^\circ$	<i>A.S. INCR., INCL:</i> $\phi, \ddot{\phi}, \dot{\xi} \delta_A = -25^\circ$
100	-2.4832206E 01	4.6557871E 01	-3.7358227E 01	6.4515310E 01
101	3.2479713E 01	-4.3176414E 01	1.1617047E 01	-2.4987926E 01
102	1.4512120E 02	-2.6798099E 02	1.4738628E 02	-3.0096104E 02
103	2.7289587E 01	-2.3595307E 01	-2.0981227E 01	2.5599077E 01
104	2.4709598E 01	-4.0790816E 01	2.6960809E 00	-2.2797608E 01
105	1.1028147E 02	-2.3413065E 02	1.4092939E 02	-2.9574088E 02
106	4.5293887E 01	-5.8591900E 01	-2.2159982E 00	-1.4406515E 01
107	3.5611690E 01	-6.2215406E 01	1.2215494E 01	-4.5470152E 01
108	4.6538339E 01	-8.6447756E 01	4.0930760E 01	-9.0817559E 01
109	3.2378933E 01	-4.2721758E 01	-8.8348844E 00	-4.0936620E 00
110	2.3250533E 01	-5.8604500E 01	8.7050776E 00	-5.2897522E 01
111	9.2423511E 01	-1.9122146E 02	1.0386436E 02	-2.2736176E 02
112	-8.5698457E 00	8.5698457E 00	-5.9396695E 00	5.9396695E 00
113	5.3787974E 01	-7.7010842E 01	9.7922635E 00	-3.8820823E 01
114	-2.5687845E 01	4.4493613E 00	-3.1261199E 01	4.7130418E 00
115	-1.3545704E 01	-5.0074560E 01	1.8138965E 01	-9.7664448E 01
116	6.0503790E 01	-7.5456073E 01	-6.9928241E-01	-1.7991080E 01
117	-6.3873031E 01	8.5026445E 01	-5.3111182E 01	7.9553131E 01
118	5.9691332E 01	-3.4806302E 01	5.5680795E 00	2.5538315E 01
119	-1.9074083E 02	2.0084345E 02	-1.4940691E 02	1.6203508E 02
120	-1.0552397E 03	9.5081517E 02	-7.6818738E 02	6.3765665E 02
121	1.1026512E 03	-1.2968539E 03	1.8998960E 02	-4.3274302E 02
122	-1.0051734E 02	9.5837545E 01	-6.8277067E 01	6.2427009E 01
123	-3.1960158E 01	7.6088476E 01	-7.8570233E 01	1.3373064E 02
124	2.1579162E 01	-5.9763522E 01	3.8701752E 01	-8.6431876E 01
125	0.	-0.	0.	-0.
126	0.	-0.	0.	-0.
127	1.0174098E 02	-8.0488048E 01	7.1988876E 01	-4.5422709E 01
128	-5.1682560E 01	8.7439989E 01	-5.7544680E 01	1.0224147E 02
129	-2.9215692E 01	3.7475255E 01	-2.5267097E 01	3.5591551E 01
130	6.1768469E 01	-1.5282704E 02	9.8132730E 01	-2.1195597E 02
131	1.4236511E 02	-3.1009830E 02	2.0057626E 02	-4.1024277E 02

<i>S</i>	-7.0402598E 02	6.1599954E 01	-6.8429770E 02	-1.1873492E 02
<i>M</i>	2.3314310E 04	-8.9831178E 04	7.8904691E 03	-9.1036576E 04
<i>T</i>	-4.1315984E 04	3.7540643E 04	-5.1452431E 04	4.6733255E 04
\bar{x}	2.3781469E 02	-3.1292647E 02	2.2130987E 02	6.9009319E 02
\bar{y}	-3.3115696E 01	-1.4582994E 03	-1.1530755E 01	7.6672119E 02
<i>AHM</i>	-1.0744828E 03	2.0156914E 03	-1.3165339E 03	2.4930447E 03
<i>FHM</i>	5.3499484E 01	-6.2490463E-02	4.6148539E 00	6.2181400E 01
ΔS	-4.9357307E 00	4.9105346E 00	-1.6978357E 01	1.6946775E 01
ΔM	-1.2957813E 01	1.2957813E 01	-8.9809231E 00	8.9809231E 00
ΔT	1.9264285E 03	-1.8011206E 03	-1.1038645E 03	1.2604994E 03

Table 4.20 Wing Panel Point Loads, Antisymm. Contributions, Flaps Extended

P	γ_{z-1}	$\ddot{z}(F) = 1/s^2$	$\ddot{\theta}(A) = 1/s^2$	$\ddot{\phi} = 1/s^2$
100	-2.5820000E 00	2.4958208E-03	1.7976891E-03	-2.0472712E-02
101	-4.4700000E-01	1.0471975E-03	9.2502449E-04	-3.1939524E-03
102	-7.2589999E 00	2.0402898E-02	1.8448130E-02	-5.0265481E-02
103	-5.0710000E 00	4.2411500E-03	2.8623399E-03	-3.4819318E-02
104	-7.0960000E 00	1.3299409E-02	1.1414453E-02	-4.8729592E-02
105	-1.1384000E 01	3.0717794E-02	2.7646015E-02	-7.8574721E-02
106	-7.5680000E 00	5.3930672E-03	3.2812189E-03	-4.6460663E-02
107	-1.0084000E 01	1.6371188E-02	1.3718288E-02	-6.1487948E-02
108	-5.6730000E 00	1.3892820E-02	1.2374384E-02	-3.4627332E-02
109	-1.0447000E 01	-1.5184364E-03	-5.2883475E-03	-5.5361843E-02
110	-2.0353000E 01	2.6982789E-02	2.1642082E-02	-1.0669197E-01
111	-1.6277000E 01	4.2341687E-02	3.8065630E-02	-8.4089961E-02
112	-3.9530000E 00	-4.0491638E-03	-5.0963613E-03	-1.7418386E-02
113	-1.0938000E 01	-1.4241886E-02	-1.8291050E-02	-5.0963613E-02
114	-3.6696000E 01	4.2760566E-02	3.3248522E-02	-1.6824974E-01
115	-4.5375000E 01	1.2191125E-01	1.1341149E-01	-1.9769344E-01
116	-1.2066000E 01	-1.0733775E-02	-1.3857914E-02	-4.5448372E-02
117	-1.9223000E 01	4.8607419E-02	4.3528510E-02	-7.2431163E-02
118	3.7737000E 01	8.2711151E-02	8.7877325E-02	1.2239994E-01
119	-1.3275900E 02	-2.4097761E-01	-2.6001914E-01	-3.9423496E-01
120	-7.5949399E 02	5.5883697E-01	3.5313246E-01	-2.6385538E 00
121	0.	-1.9006635E 01	-1.9006635E 01	0.
122	-7.6464000E 01	1.9928169E-01	1.8017033E-01	-2.1848031E-01
123	-2.3221000E 01	-2.9635690E-02	-3.5709435E-02	-4.4558255E-02
124	-2.0291000E 01	5.2499503E-02	4.7088982E-02	-3.9374627E-02
125	0.	0.	0.	0.
126	0.	0.	0.	0.
127	-9.1999999E 01	6.6497043E-02	4.1556289E-02	2.9153979E-01
128	-1.3018000E 01	4.2079887E-02	4.2132247E-02	-2.5761059E-02
129	-1.1582000E 01	3.7419858E-02	3.7489671E-02	-4.1067596E-02
130	-1.4962000E 01	4.2149701E-02	3.8100537E-02	-7.6358153E-02
131	-1.1928000E 01	3.3597587E-02	3.0368728E-02	-8.2554072E-02

S	-1.2069839E 03	9.8263779E-01	6.7237062E-01	-4.3897821E 00
M	-5.5917984E 04	5.5874798E 01	4.1440974E 01	-2.2742506E 02
T	-4.5505034E 04	-1.0062115E 01	-2.1534894E 01	-1.5802378E 02
\bar{x}	2.5879856E 02	3.0673990E 02	3.2852831E 02	2.6050191E 02
\bar{y}	4.6328689E 01	5.6862049E 01	6.1634125E 01	5.1807825E 01
AHM	-1.6408000E 01	-2.5237460E-02	-2.9670597E-02	-9.6970491E-02
FHM	8.3639998E 01	-3.1660272E-01	3.1700414E-01	2.2722441E-01

Table 4.21 Wing Panel Point Loads, Unit Inertia

FUSELAGE REACTIONS ... INERTIA	400	9F	9M	9R	TOTAL
INCREMENTAL WING ROOT SHEAR					
LINEAR ACCELERATION	1.2360000E 01	-6.0827999E 01	-2.7620000E 01	-5.8903999E 01	-1.3499200E 02
PITCHING (FWD C.G.)	0.	0.	-0.	-0.	0.
(AFT C.G.)	0.	0.	-0.	-0.	0.
TOTALS (FWD C.G.)	1.2360000E 01	-6.0827999E 01	-2.7620000E 01	-5.8903999E 01	-1.3499200E 02
(AFT C.G.)	1.2360000E 01	-6.0827999E 01	-2.7620000E 01	-5.8903999E 01	-1.3499200E 02
ROLLING	0.	0.	0.	0.	0.
INCREMENTAL WING ROOT BENDING					
LINEAR ACCELERATION	0.	0.	-1.5468000E 01	0.	-1.5468000E 01
PITCHING (FWD C.G.)	0.	0.	-0.	0.	0.
(AFT C.G.)	0.	0.	-0.	0.	0.
TOTALS (FWD C.G.)	0.	0.	-1.5468000E 01	0.	-1.5468000E 01
(AFT C.G.)	0.	0.	-1.5468000E 01	0.	-1.5468000E 01
ROLLING	0.	0.	0.	0.	0.
INCREMENTAL WING ROOT TORSION					
LINEAR ACCELERATION	-1.0197000E 03	-4.8954359E 03	-1.0122720E 03	-8.3439999E 01	-6.9274079E 03
PITCHING (FWD C.G.)	0.	0.	-0.	-0.	0.
(AFT C.G.)	0.	0.	-0.	-0.	0.
TOTALS (FWD C.G.)	-1.0197000E 03	-4.8954359E 03	-1.0122720E 03	-8.3439999E 01	-6.9274079E 03
(AFT C.G.)	-1.0197000E 03	-4.8954359E 03	-1.0122720E 03	-8.3439999E 01	-6.9274079E 03
ROLLING	0.	0.	0.	0.	0.

Table 4.22 Fuselage Reactions, Unit Inertia

P	BASIC ($\alpha = 0$)	ADDITIONAL DUE TO α°	ADDITIONAL DUE TO ϕ, ψ	ADDITIONAL DUE TO δ_A°
100	-2.7623767E 01	3.9361809E 00	-1.1740656E-01	-2.0749147E 00
101	-1.8907486E 01	1.0539630E 01	-3.0582968E-01	1.0215909E 00
102	2.0092680E 01	1.8758817E 01	-5.3830278E-01	1.1733753E 01
103	-6.6312137E 01	2.4116071E 01	-6.9463669E-01	-3.5282319E-01
104	-2.4429969E 01	1.5887730E 01	-4.2891790E-01	1.5358409E 00
105	5.0869926E 01	9.4423275E 00	-2.1180747E-01	1.1828246E 01
106	-6.0499031E 01	3.3472441E 01	-8.7791150E-01	1.2700300E 00
107	-2.9123438E 01	2.0351965E 01	-5.1050118E-01	2.5407937E 00
108	2.2521553E 00	7.2314882E 00	-1.4309085E-01	3.8115574E 00
109	-6.5054917E 01	3.7427208E 01	-9.2830549E-01	9.8779422E-01
110	-2.4509625E 01	2.3818303E 01	-5.1918418E-01	3.3764886E 00
111	5.3534628E 01	1.0950620E 01	-1.2735595E-01	9.4357209E 00
112	0.	0.	0.	0.
113	-5.7293508E 01	4.6378741E 01	-9.1608480E-01	2.2179048E 00
114	-1.8382917E 01	2.7106619E 01	-4.7738393E-01	2.0283878E 00
115	7.0843052E 01	8.1997786E 00	-5.7222575E-02	6.0760729E 00
116	-7.7618701E 01	6.1035678E 01	-9.8487452E-01	1.4280209E 00
117	-1.5173070E 01	-4.3905897E 00	1.6002999E-01	-2.0202665E 00
118	-5.0195758E 01	3.1071782E 01	-4.1246393E-01	-2.3766537E 00
119	-3.5270176E 01	1.7275300E 01	-1.8628204E-01	-9.6484954E-01
120	-0.	1.6054114E 02	-1.9848705E 00	9.9730933E 00
121	-0.	1.3042987E 03	-1.3909901E 01	1.8547375E 01
122	-2.0344591E 01	3.4788177E 00	3.9899863E-02	4.4695464E-01
123	-1.2977294E 02	5.7040787E 01	-5.2743701E-01	-4.2144853E 00
124	2.5966145E 01	7.5743017E 00	3.3174194E-02	3.6468057E 00
125	0.	0.	0.	0.
126	0.	0.	0.	0.
127	0.	-5.6829205E 00	2.5276157E-01	-2.0297660E 00
128	3.1738646E 01	-3.4908765E 00	2.3507850E-02	-3.4150218E 00
129	-6.4968538E-01	-6.7631528E-01	5.2170665E-03	-7.8883144E-01
130	8.8464024E 01	1.7828172E 00	-4.1049610E-02	8.6965712E 00
131	6.3701611E 01	3.3986763E 00	-9.2658340E-02	1.5019397E 01
S	-4.9695343E 02	6.3124511E 02	-1.0716765E 01	6.1355060E 01
M	-3.3436514E 04	4.3153899E 04	-8.8777381E 02	6.3527098E 03
T	-3.9737080E 04	3.1582424E 04	-4.9903424E 02	3.6056479E 02
\bar{x}	2.1653862E 02	2.4646805E 02	2.4993425E 02	2.9062331E 02
\bar{y}	6.7282992E 01	6.8363142E 01	8.2839718E 01	1.0354011E 02
AHM	-5.1280982E 02	-1.9669380E 01	5.1440783E-01	-8.9890347E 01
FHM	-3.2061084E 01	2.6363039E 01	-1.8276938E-01	-5.1035128E 00
ΔS	-3.2562103E 01	4.2067909E 01	-2.4266613E-01	2.3996830E-03
ΔM	0.	0.	0.	0.
ΔT	-7.8722891E 03	6.4750769E 03	-4.0521629E 01	-1.1967560E 01

Table 4.23 Wing Panel Point Loads, Unit Aerodynamic, $M = .285$ at 2500 Ft. ($q = 109.8$ psf), Flaps Retracted

P	BASIC ($\alpha = 0$)	ADDITIONAL DUE TO α°	ADDITIONAL DUE TO $\dot{\phi}, \dot{\psi}$	ADDITIONAL DUE TO S_A°
100	-2.4979388E 01	5.6261267E 00	-1.2671084E-01	-2.0749147E 00
101	8.8396279E-01	1.2666847E 01	-3.1719168E-01	1.0215909E 00
102	1.0435280E 02	1.9707567E 01	-5.0767254E-01	1.1733753E 01
103	-2.0411059E 01	2.6105833E 01	-6.8663175E-01	-3.5282319E-01
104	4.2871765E 00	1.6627318E 01	-4.4132743E-01	1.5358409E 00
105	1.1462168E 01	7.1488028E 00	-1.9602312E-01	1.1828246E 01
106	5.0533205E 00	2.8963720E 01	-7.6025093E-01	1.2700300E 00
107	1.7539083E 01	2.1356586E 01	-5.2210782E-01	2.5407937E 00
108	3.0024846E 01	1.3749450E 01	-2.8396470E-01	3.8115574E 00
109	-7.3867092E 00	2.8543620E 01	-6.8497436E-01	9.8779422E-01
110	6.4275659E 01	2.6015052E 01	-5.2683426E-01	3.3764886E 00
111	2.2120535E 02	2.3486485E 01	-3.6869419E-01	9.4357209E 00
112	0.	0.	0.	0.
113	1.9544692E 01	4.1391847E 01	-7.5858483E-01	2.2179048E 00
114	1.2002807E 02	2.9671524E 01	-4.8072946E-01	2.0283878E 00
115	1.1019015E 03	1.7951203E 01	-2.0287409E-01	6.0760729E 00
116	1.9344719E 02	6.4804754E 01	-9.4316823E-01	1.4280209E 00
117	4.1897302E 01	2.1748905E 00	7.3129967E-02	-2.0202665E 00
118	-6.6343012E 00	3.1061934E 01	-3.7722249E-01	-2.3766537E 00
119	6.1498024E 01	2.0907390E 01	-2.0185812E-01	-9.6484954E-01
120	1.1853867E 03	1.6476633E 02	-1.8283084E 00	9.9730933E 00
121	-8.1993535E 03	1.3108611E 03	-1.2624084E 01	1.8547375E 01
122	1.2963035E 02	1.0752846E 01	-2.6493747E-02	4.4695464E-01
123	9.2206054E 01	6.6626044E 01	-5.3997816E-01	-4.2144853E 00
124	1.8747732E 02	1.3965012E 01	9.9772364E-03	3.6468057E 00
125	0.	0.	0.	0.
126	0.	0.	0.	0.
127	4.5218002E 01	-9.1015568E 00	2.6234101E-01	-2.0297660E 00
128	5.5103424E 02	0.	-0.	-3.4150218E 00
129	7.0694438E 02	0.	-0.	-7.8883144E-01
130	3.2971299E 02	0.	-0.	8.6965712E 00
131	1.6324176E 02	0.	-0.	1.6019397E 01

S	3.7058496E 03	6.9407116E 02	-1.0698494E 01	6.1355060E 01
M	2.2662991E 05	4.6782018E 04	-8.8776729E 02	6.3527098E 03
T	7.3175181E 04	3.2379601E 04	-4.5793334E 02	3.6056479E 02
\bar{Z}	2.7675414E 02	2.4984829E 02	2.5369647E 02	2.9062331E 02
\bar{U}	6.1154642E 01	6.7402336E 01	8.2980587E 01	1.0354011E 02
AHM	-2.7401338E 03	0.	-0.	-8.9890347E 01
FHM	-7.6235009E 03	0.	-0.	-5.1035128E 00
ΔS	2.2207855E 02	5.0839760E 01	-2.4752474E-01	2.3996830E-03
ΔM	0.	0.	0.	0.
ΔT	7.6499692E 03	8.1432680E 03	-4.3092113E 01	-1.1967560E 01

Table 4.24 Wing Panel Point Loads, Unit Aerodynamic, $M = .285$ at 2500 Ft. ($q = 109.8$ psf), Flaps Extended 45°

P	BASIC ($\alpha = 0$)	ADDITIONAL DUE TO α°	ADDITIONAL DUE TO $\dot{\phi}, \%5$	ADDITIONAL DUE TO δ_A°
100	-3.1323018E 00	4.1208704E 01	-2.9386901E-01	-1.4182470E 01
101	-5.3956537E 01	1.0237687E 02	-8.2094600E-01	6.9827839E 00
102	-2.2748238E 02	1.6895603E 02	-1.3942424E 00	8.0202620E 01
103	-2.1430818E 02	2.1092485E 02	-1.7745477E 00	-2.4116195E 00
104	2.3884119E 01	1.2832723E 02	-1.1441568E 00	1.0497788E 01
105	1.2667740E 02	5.1700519E 01	-5.6476811E-01	8.0848496E 01
106	-1.4938821E 02	2.4937546E 02	-2.2503283E 00	8.6809148E 00
107	1.9725479E 02	1.5281562E 02	-1.3516671E 00	1.7366850E 01
108	5.4389778E 02	5.6255775E 01	-4.5300588E-01	2.6052785E 01
109	-1.4716507E 02	2.6990368E 02	-2.3754110E 00	6.7517750E 00
110	2.5993323E 02	1.7912121E 02	-1.3687400E 00	2.3078998E 01
111	5.2977293E 02	9.1533290E 01	-3.8874146E-01	6.4492097E 01
112	0.	0.	0.	0.
113	-1.7176069E 02	3.3298127E 02	-2.3120467E 00	1.5159838E 01
114	1.7001734E 02	2.0259699E 02	-1.2570826E 00	1.3864446E 01
115	6.2417703E 01	8.7946830E 01	-2.9274100E-01	4.1531193E 01
116	-3.4154051E 02	4.5111891E 02	-2.5813295E 00	9.7608155E 00
117	3.1228543E 02	-8.2013446E 01	5.8887184E-01	-1.3808978E 01
118	-3.2006894E 02	1.9093714E 02	-9.8917766E-01	-1.6244936E 01
119	-1.0712141E 02	9.0157582E 01	-3.9340194E-01	-6.5949243E 00
120	6.3183056E 02	1.2212294E 03	-5.6611933E 00	6.8168142E 01
121	-6.6659184E 04	1.3853005E 04	-6.0899786E 01	1.2677512E 02
122	1.0582613E 02	-1.0621979E 01	2.0237380E-01	3.0550874E 00
123	-4.3353640E 02	3.5230083E 02	-1.2640405E 00	-2.8806874E 01
124	-2.0507740E 02	4.4253982E 01	1.8636252E-01	2.4926550E 01
125	0.	0.	0.	0.
126	0.	0.	0.	0.
127	-7.0784254E 02	2.1524826E 01	5.5580461E-01	-1.3873867E 01
128	-1.4207682E 02	1.3862941E 01	-4.6080487E-02	-2.3342376E 01
129	-2.7724203E 02	1.2014545E 01	-5.7351779E-02	-5.3918250E 00
130	-3.0939426E 02	6.9141489E 00	-5.9943259E-02	5.9442840E 01
131	-2.5810063E 02	1.1381908E 01	-9.7221673E-02	1.0949588E 02

S	5.8925939E 02	4.5833865E 03	-2.7953827E 01	4.1937437E 02
M	7.8834760E 04	3.2767779E 05	-2.3255154E 03	4.3422077E 04
T	-1.5742590E 05	2.2758150E 05	-1.3126823E 03	2.4645344E 03
\bar{z}	5.6365892E 02	2.4684643E 02	2.4954105E 02	2.9062331E 02
\bar{y}	1.3378617E 02	7.1492504E 01	8.3191304E 01	1.0354013E 02
AHM	3.3208522E 03	-1.1737138E 02	1.0003243E 00	-6.1441899E 02
FHM	-3.8289174E 02	2.1875195E-01	-3.2631131E-02	-3.4883559E 01
ΔS	-5.1601794E 02	2.8084341E 02	-5.3973839E-01	1.6485214E-02
ΔM	0.	0.	0.	0.
ΔT	-9.4712508E 04	4.5289982E 04	-9.6200194E 01	-8.1800731E 01

Table 4.25 Wing Panel Point Loads, Unit Aerodynamic, M = .8 at 6316 Ft. ($q = 750.8$ psf)

<i>P</i>	<i>BASIC</i> (<i>SFC</i>)	<i>ADDITIONAL</i> <i>DUE TO α</i>	<i>ADDITIONAL</i> <i>DUE TO $\dot{\phi}$, $\dot{\psi}$</i>	<i>ADDITIONAL</i> <i>DUE TO δ_R</i>
100	-1.1575466E 02	2.2856569E 01	-3.3947518E-01	-1.5993156E 01
101	-9.3413495E 01	5.9363194E 01	-8.4038082E-01	7.8742819E 00
102	2.1267789E 02	9.5869821E 01	-1.3412865E 00	9.0442150E 01
103	-2.5799531E 02	1.2683087E 02	-1.7706781E 00	-2.7195120E 00
104	-1.7318308E 02	9.6056080E 01	-1.1731327E 00	1.1838049E 01
105	2.2474243E 02	6.5281290E 01	-5.7558733E-01	9.1170484E 01
106	-1.3045962E 02	1.7486011E 02	-2.0331334E 00	9.7892153E 00
107	-3.5202486E 02	1.3575624E 02	-1.3881244E 00	1.9584089E 01
108	-5.7359010E 02	9.6652369E 01	-7.4311531E-01	2.9378963E 01
109	-2.6467053E 02	2.0527906E 02	-2.0157862E 00	7.6137800E 00
110	-4.3265623E 02	1.7870255E 02	-1.3997338E 00	2.6025513E 01
111	-4.1470512E 01	1.5212604E 02	-7.8368133E-01	7.2729245E 01
112	0.	0.	0.	0.
113	-4.2709169E 02	2.9324382E 02	-2.0091875E 00	1.7095304E 01
114	-4.0446115E 02	2.1709244E 02	-1.2654796E 00	1.5634532E 01
115	6.8232219E 02	1.4094106E 02	-5.2177185E-01	4.6833528E 01
116	-6.7603421E 02	4.3170218E 02	-2.2362831E 00	1.1006989E 01
117	-5.9357492E 02	1.3076439E 00	2.2753435E-01	-1.5571944E 01
118	-6.3357688E 02	1.8740407E 02	-8.0032700E-01	-1.8318929E 01
119	-4.0832853E 02	1.2241511E 02	-4.0489999E-01	-7.4369169E 00
120	-2.7811434E 03	1.5649208E 03	-5.8792616E 00	7.6871228E 01
121	-8.6621600E 03	1.2519447E 04	-4.1070179E 01	1.4296060E 02
122	-1.8308017E 02	5.7426145E 01	-9.4729736E-03	3.4450991E 00
123	-1.2666184E 03	4.1712756E 02	-1.1242417E 00	-3.2484671E 01
124	-2.2140387E 02	1.3080381E 02	-1.0989100E-02	2.8108960E 01
125	0.	0.	0.	0.
126	0.	0.	0.	0.
127	-1.9040640E 03	1.8479584E 01	6.6604817E-01	-1.5645156E 01
128	2.3512307E 01	0.	-0.	-2.6322517E 01
129	3.2123758E 02	0.	-0.	-6.0802038E 00
130	1.3020867E 03	0.	-0.	6.7031971E 01
131	5.9686351E 02	0.	-0.	1.2347530E 02

<i>S</i>	-8.9107890E 03	4.9740185E 03	-2.8438494E 01	4.7291627E 02
<i>N</i>	-4.7100217E 05	3.1380064E 05	-2.3565044E 03	4.8965811E 04
<i>I</i>	-4.6820112E 05	2.3217440E 05	-1.1993752E 03	2.7791837E 03
\bar{x}	2.4395683E 02	2.4970194E 02	2.5432564E 02	2.9062331E 02
\bar{y}	5.2857516E 01	6.3087951E 01	8.2863193E 01	1.0354013E 02
<i>A_{HN}</i>	-1.4600958E 04	0.	-0.	-6.9286239E 02
<i>F_{HN}</i>	1.2971177E 03	0.	-0.	-3.9337173E 01
ΔS	-1.0669250E 03	3.9068600E 02	-5.8028984E-01	1.8579483E-02
ΔM	0.	0.	0.	0.
ΔT	-1.3809725E 05	5.3105209E 04	-8.6831977E 01	-9.2244304E 01

Table 4.26 Wing Panel Point Loads, Unit Aerodynamic, $M = .9$ at 9340 Ft. ($q = 846.7$ psf)

4.5 FUSELAGE LOADS

Fuselage internal loads, as a result of the various flight and landing conditions, are presented in this section. All loads and loading conditions are limit. Only the 9200 pound gross weight with center-of-gravity at fuselage stations 240 and 246 were considered.

The body axis sign convention used for the fuselage internal loads of this section is as follows:

- $+F_x$ ~ Net load forward of the fuselage station in question, acting aft, or in other words, compression exists at the station in question.
- $+F_y$ ~ Net load forward of the station in question, acting to the left.
- $+F_z$ ~ Net load forward of the station in question, acting upward.
- $+M_x$ ~ Net moment acting forward of the station in question which tends to roll the airplane to the right.
- $+M_y$ ~ Net moment acting forward of the station in question which tends to rotate the airplane nose-up and produce compression in the upper surface.
- $+M_z$ ~ Net moment acting forward of the station in question which tends to rotate the airplane nose-right and produce compression on the right side.

This sign convention is shown as a diagram in Figure 4. 21.

Fuselage loading envelope curves for all flight and landing conditions are shown in Figures 4 22 through 4. 24. The particular loading condition which produced the various portions of each curve are designated in each figure as an F, L, LG, AF, SPC, ROLL, or HSC number. Each of these designations refer to a particular loading condition discussed in detail later in this section. The loading conditions are broken down into the following categories:

- F ~ Symmetrical flight
- L ~ Landing

LG ~ Lateral gust

AF ~ Unsymmetrical flight

SPC ~ Spin with parachute

ROLL ~ Rolling maneuvers

HSC ~ High-speed parachute

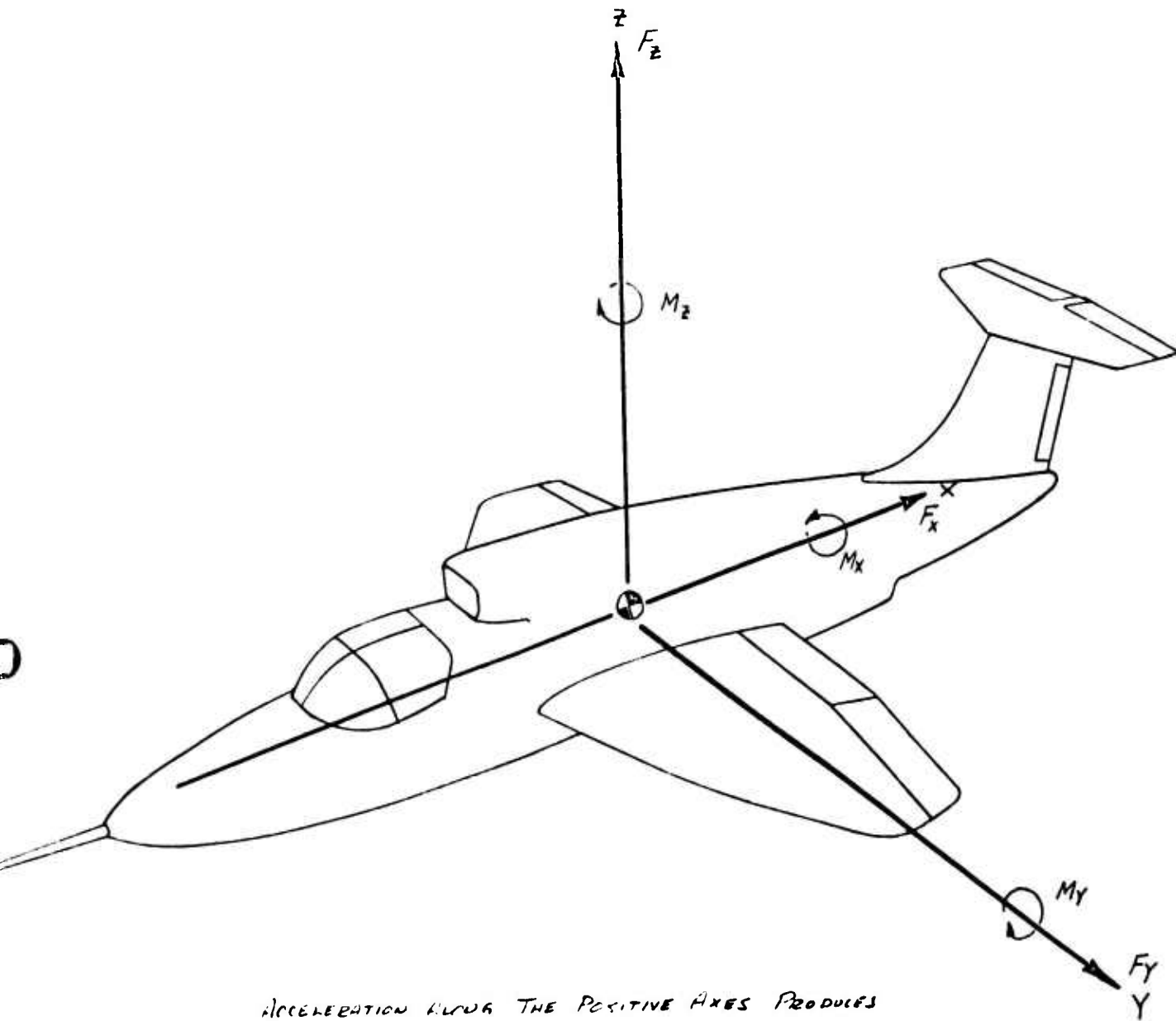

ACCELERATION ALONG THE POSITIVE AXES PRODUCES
 POSITIVE LOAD FACTORS n_x , n_y , AND n_z .

Figure 4.21 Fuselage Loads Body - Axes System

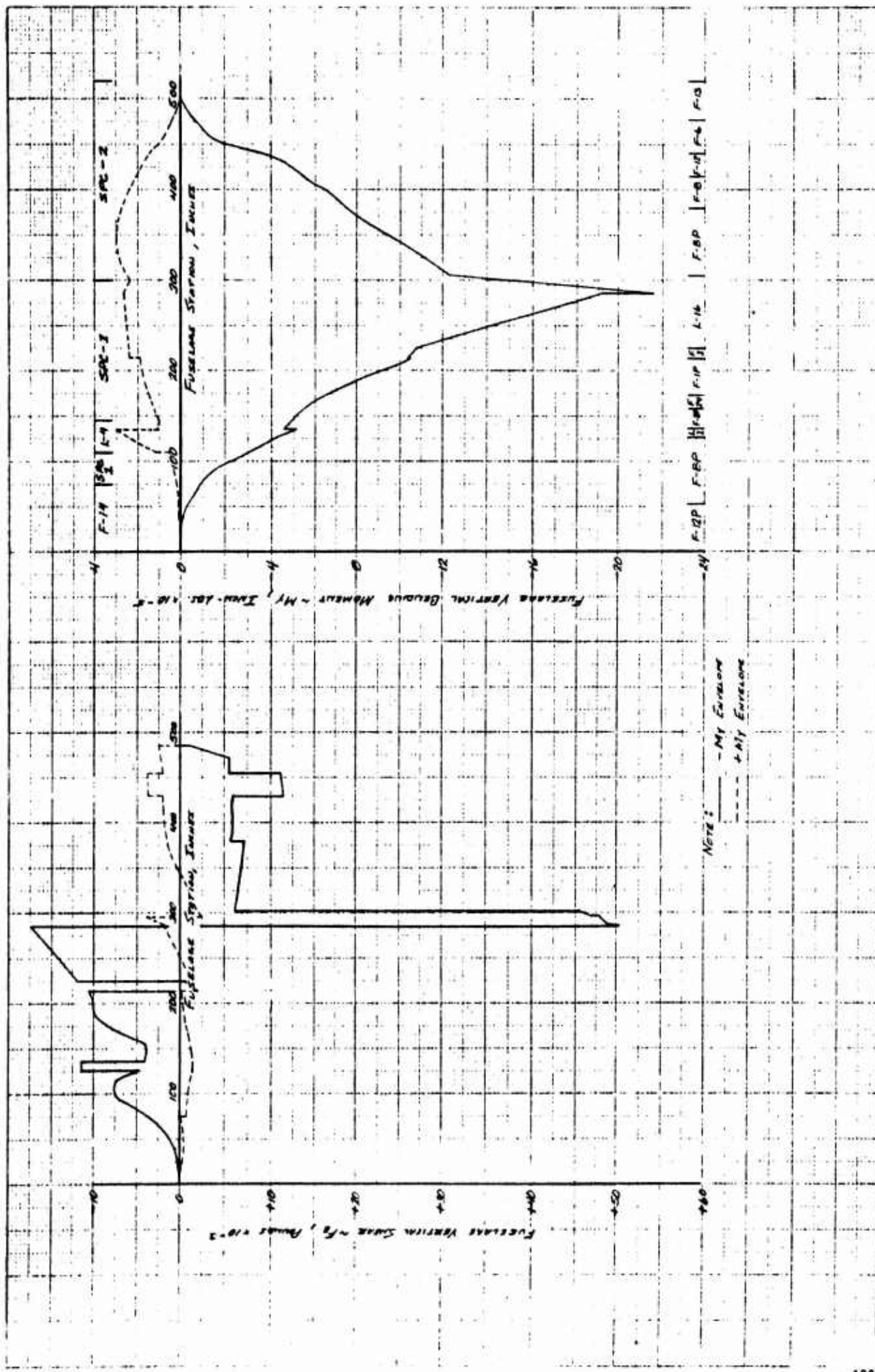

Figure 4.22 Fuselage Vertical Loading Envelope Curves Symmetrical Flight and Landing Conditions

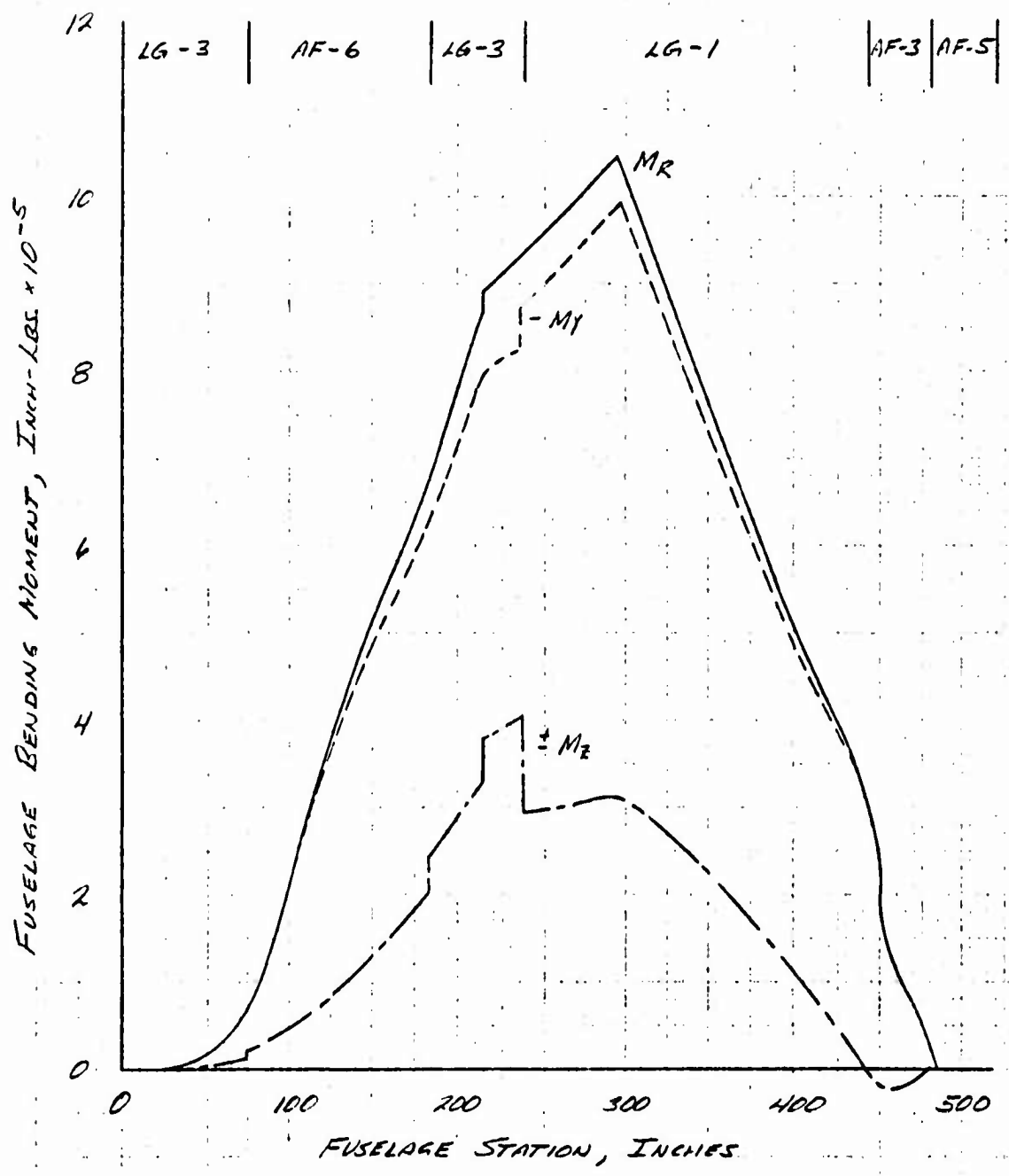

Figure 4.23 Fuselage Loading Envelope Curves Unsymmetrical Flight and Landing Conditions

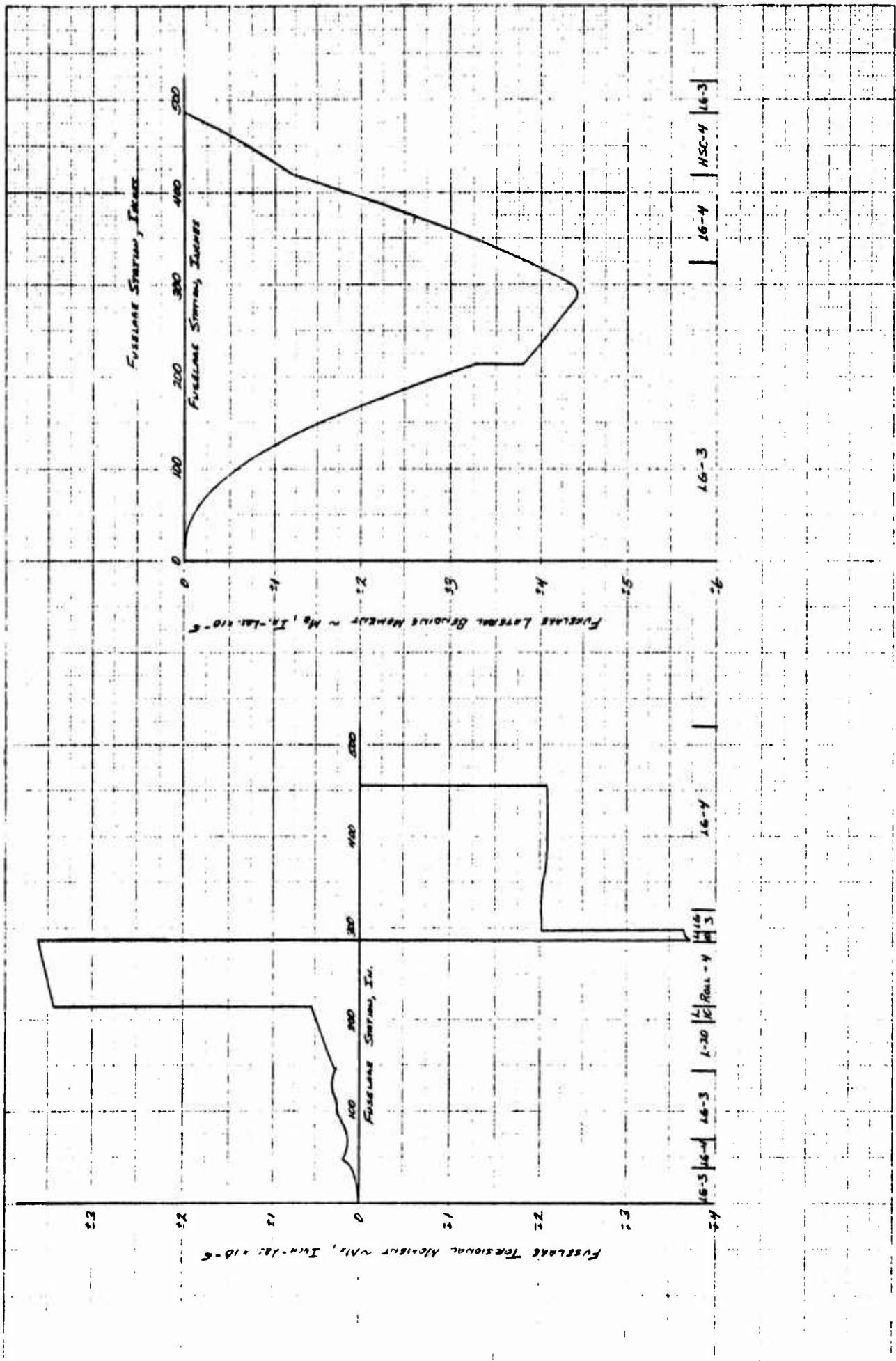

Figure 4.24 Fuselage Loading Envelope Curves Unsymmetrical Flight and Landing Conditions

4.5.1 Symmetrical Flight Maneuvers

The fuselage distributed loads which result from selected symmetrical flight maneuvers are shown in Tables 4.27 through 4.47. Only the loads resulting from the flight conditions which contribute to the fuselage loading-envelope curves of Figure 4.25 and 4.26 are presented in the tables. Refer to Table 4.1 for definitions of the conditions.

Figure 4.25 shows fuselage vertical loading-envelope curves for the flaps-down flight conditions. The conditions which produce the critical bending moment along the length of the fuselage are identified in the figure. The curves of Figure 4.26 present the same information for symmetrical flaps-up flight conditions.

4.5.2 Rudder and Lateral-Gust Conditions

The fuselage distributed loads resulting from the rudder and lateral gust flight conditions are shown in Figures 4.27 through 4.34. Each of these unsymmetrical flight conditions is described in Table 4.2. Figure 4.27 shows the resultant bending-moment envelope curve for the dynamic-overswing condition where the resultant bending moment is

$$M_R = \sqrt{M_Y^2 + M_Z^2}$$

The vertical bending moment (M_Y) and lateral bending moment (M_Z) curves shown on the figure present the values of these parameters which produce the M_R envelope and are not necessarily the maximum value of these parameters at any given fuselage station. Figure 4.28 shows similar curves for the lateral gust conditions.

Shown on Figure 4.29 is the fuselage torsional-moment (M_X) envelope curve for all lateral gust and rudder maneuver conditions. The particular conditions which result in the critical loads at the various fuselage locations are indicated at the top of the figure. The vertical bending moment (M_Z) envelope curve for the same flight conditions is shown in Figure 4.30.

FUSELAGE SHEAR AND MOMENT PROGRAM - JOB NUMBER 1105 - 1/9/63

SYMMETRIC FLIGHT CONDITION F-1

OUTPUT

F.S.	FX	FY	FZ	MX	MY	MZ
-70.00	0.	0.	0.	0.	0.	0.
0.	0.	0.	-2.6439999E 01	0.	-7.7692391E 02	0.
20.00	0.	0.	1.2091012E 02	0.	6.0292535E 02	0.
35.20	0.	0.	-4.1937744E 01	0.	1.5602167E 03	0.
47.00	0.	0.	-5.0544323E 02	0.	-1.5586025E 03	0.
59.00	0.	0.	-1.3278098E 03	0.	-1.1147707E 04	0.
71.00	0.	0.	-2.5728977E 03	0.	-3.4806185E 04	0.
82.60	0.	0.	-4.4600795E 03	0.	-7.4820554E 04	0.
91.00	0.	0.	-6.0807096E 03	0.	-1.1893880E 05	0.
110.00	0.	0.	-7.4468716E 03	0.	-2.5572691E 05	0.
110.00	0.	0.	-7.4468716E 03	0.	-2.5572691E 05	0.
128.50	0.	0.	-5.2377643E 03	0.	-3.3761819E 05	0.
136.50	0.	0.	-4.7548659E 03	0.	-3.9899890E 05	0.
136.50	0.	0.	-4.7548659E 03	0.	-3.9899890E 05	0.
150.00	0.	0.	-6.3638241E 03	0.	-4.7817845E 05	0.
165.20	0.	0.	-7.2983859E 03	0.	-5.6080034E 05	0.
177.20	0.	0.	-8.6195143E 03	0.	-6.7685874E 05	0.
188.90	0.	0.	-9.8165798E 03	0.	-7.8466844E 05	0.
201.90	0.	0.	-1.0035769E 04	0.	-9.1470741E 05	0.
214.00	0.	0.	-1.0541682E 04	0.	-1.0371266E 06	0.
214.00	0.	0.	1.8241033E 03	0.	-1.0371266E 06	0.
286.00	-0.	0.	-1.0930604E 03	0.	-9.8253324E 05	0.
286.00	-0.	0.	-1.0930604E 03	0.	-9.8253324E 05	0.
287.00	-0.	0.	-2.2992072E 03	0.	-9.8204566E 05	0.
296.50	-0.	0.	-3.4905206E 03	0.	-1.0007782E 06	0.
296.50	-0.	0.	7.5941334E 03	0.	-1.0007782E 06	0.
315.89	-0.	0.	6.3361440E 03	0.	-8.5920396E 05	0.
315.89	-0.	0.	6.3361440E 03	0.	-8.5920396E 05	0.
328.10	-0.	0.	6.0063406E 03	0.	-8.5920396E 05	0.
341.00	-0.	0.	5.7243205E 03	0.	-7.8419725E 05	0.
366.00	-0.	0.	4.9307624E 03	0.	-7.0841289E 05	0.
392.12	-0.	0.	4.6192783E 03	0.	-5.7771266E 05	0.
392.12	-0.	0.	4.6192783E 03	0.	-5.7771266E 05	0.
407.00	-0.	0.	4.4520666E 03	0.	-4.5274778E 05	0.
419.00	-0.	0.	4.2877822E 03	0.	-3.8547916E 05	0.
429.23	-0.	0.	4.1806105E 03	0.	-3.3283928E 05	0.
429.23	-0.	0.	7.2891734E 03	0.	-2.8956544E 05	0.
446.55	-0.	0.	7.1797515E 03	0.	-2.8956544E 05	0.
455.22	-0.	0.	7.1399646E 03	0.	-1.6425137E 05	0.
455.22	-0.	0.	3.3372066E 03	0.	-1.0214262E 05	0.
470.80	-0.	0.	3.2515788E 03	0.	-1.0214262E 05	0.
486.39	-0.	0.	3.1743313E 03	0.	-5.0909500E 04	0.
486.39	-0.	0.	6.5768402E 01	0.	-7.8112500E 02	0.
500.00	-0.	0.	2.5202881E 01	0.	-7.8112500E 02	0.
520.00	-0.	0.	2.9296675E-03	0.	-2.6112500E 02	0.
					7.5000000E-01	0.

Table 4.27 Fuselage Loading Symmetric Flight Maneuver

SYMMETRIC FLIGHT CONDITION

OUTPUT

F.S.	FX	FY	FZ	MX	MY	MZ
-70.00	0.	0.	0.	0.	0.	0.
0.	0.	0.	-2.643999E 01	0.	-7.7692391E 02	0.
20.00	0.	0.	1.0856499E 02	0.	4.8764963E 02	0.
35.20	0.	0.	-6.4175346E 01	0.	1.1808694E 03	0.
47.00	0.	0.	-5.3484267E 02	0.	-2.2420818E 03	0.
59.00	0.	0.	-1.3639949E 03	0.	-1.2225249E 04	0.
71.00	0.	0.	-2.6153782E 03	0.	-3.6356278E 04	0.
82.00	0.	0.	-4.5382176E 03	0.	-7.6897158E 04	0.
91.00	0.	0.	-6.1326575E 03	0.	-1.2143563E 05	0.
110.00	0.	0.	-7.5138952E 03	0.	-2.5932663E 05	0.
122.50	0.	0.	-5.3202888E 03	0.	-2.5932663E 05	0.
136.50	0.	0.	-4.8547554E 03	0.	-3.4215075E 05	0.
150.00	0.	0.	-4.8547554E 03	0.	-4.0481093E 05	0.
165.20	0.	0.	-6.4777429E 03	0.	-4.0481093E 05	0.
177.20	0.	0.	-7.4146426E 03	0.	-4.8543920E 05	0.
198.90	0.	0.	-8.7397609E 03	0.	-5.982784E 05	0.
201.90	0.	0.	-9.9477816E 03	0.	-6.8728018E 05	0.
214.00	0.	0.	-1.0179774E 04	0.	-7.9656067E 05	0.
214.00	0.	0.	-1.0697967E 04	0.	-9.2838763E 05	0.
286.00	-1.1129016E 03	0.	-7.7947009E 02	0.	-1.0526243E 06	0.
286.00	-1.1129016E 03	0.	-3.746177E 03	0.	-1.0138431E 06	0.
286.00	-1.1129016E 03	0.	1.0965396E 03	0.	-1.1502736E 06	0.
287.00	-2.9127734E 02	0.	-1.0999963E 02	0.	-1.1477458E 06	0.
296.50	-2.9127734E 02	0.	-1.3045509E 03	0.	-1.1450688E 06	0.
296.50	-2.9127734E 02	0.	9.4349312E 03	0.	-1.1430207E 06	0.
315.89	-2.9127734E 02	0.	8.1726418E 03	0.	-1.1430207E 06	0.
325.10	-2.9127734E 02	0.	7.8417059E 03	0.	-9.6579950E 05	0.
341.00	-2.9127734E 02	0.	7.5594916E 03	0.	-8.683778E 05	0.
366.00	-2.9127734E 02	0.	6.7659355E 03	0.	-7.6891907E 05	0.
392.12	-2.9127734E 02	0.	6.4544514E 03	0.	-5.9233953E 05	0.
392.12	-6.8177510E 02	0.	4.1638305E 03	0.	-4.1944022E 05	0.
407.00	-6.8177510E 02	0.	3.9966189E 03	0.	-4.1775966E 05	0.
419.00	-6.8177510E 02	0.	3.8323345E 03	0.	-3.5726843E 05	0.
429.23	-6.8177510E 02	0.	3.7251628E 03	0.	-3.1009397E 05	0.
429.23	-6.8177510E 02	0.	6.7243975E 03	0.	-2.7147912E 05	0.
446.55	-6.8177510E 02	0.	6.6149756E 03	0.	-2.7147912E 05	0.
455.22	-6.8177510E 02	0.	6.5751887E 03	0.	-1.5594650E 05	0.
455.22	-6.8664551E-05	0.	3.2278772E 03	0.	-9.8734374E 04	0.
470.80	-6.8664551E-05	0.	3.1422495E 03	0.	-9.8734374E 04	0.
486.39	-6.8664551E-05	0.	3.0650019E 03	0.	-4.9204812E 04	0.
486.39	-6.8664551E-05	0.	2.5201660E 01	0.	-7.8131250E 02	0.
500.00	-6.8664551E-05	0.	2.5201660E 01	0.	-7.8131250E 02	0.
520.00	-6.8664551E-05	0.	1.7989844E-03	0.	-2.6093750E 02	0.
520.00	-6.8664551E-05	0.	1.7989844E-03	0.	6.2500000E-01	0.

Table 4.28 Fuselage Loading Symmetric Flight Maneuver

FUSELAGE SHEAR AND MOMENT PROGRAM - JOB NUMBER 1105 - 2/11/63

SYMMETRIC FLIGHT CONDITION F-6

OUTPUT

F.S.	FX	FY	FZ	MX	MY	MZ
-70.00	0.	0.	0.	0.	0.	0.
0.	5.7674200E-01	0.	-3.1105644E-01	0.	-3.2196541E 01	0.
20.00	1.2370793E 00	0.	-2.2483617E 02	0.	-1.5471564E 03	0.
35.20	1.5315230E 00	0.	-6.9861574E 02	0.	-8.2335644E 03	0.
47.00	4.2169718E 00	0.	-1.2387693E 03	0.	-1.9603795E 04	0.
59.00	8.5085914E 00	0.	-1.9287331E 03	0.	-3.8680446E 04	0.
71.00	1.2458465E 01	0.	-3.0800211E 03	0.	-6.8010418E 04	0.
82.60	1.5996037E 01	0.	-4.9191433E 03	0.	-1.1388320E 05	0.
91.00	1.8828028E 01	0.	-6.5047594E 03	0.	-1.6166811E 05	0.
110.00	2.6414220E 01	0.	-7.6599535E 03	0.	-2.0534103E 05	0.
110.00	2.6414220E 01	0.	-7.6599535E 03	0.	-2.0534103E 05	0.
122.50	3.1231890E 01	0.	-5.4239297E 03	0.	-3.8990544E 05	0.
136.50	3.7648511E 01	0.	-4.0178986E 03	0.	-4.5130793E 05	0.
136.50	3.7648511E 01	0.	-4.0178986E 03	0.	-4.5130793E 05	0.
150.00	3.8556458E 01	0.	-3.8440615E 03	0.	-5.0417346E 05	0.
165.20	4.6137660E 01	0.	-3.8663070E 03	0.	-5.6335120E 05	0.
177.20	5.5403829E 01	0.	-3.5712549E 03	0.	-6.0854586E 05	0.
188.90	5.8874533E 01	0.	-3.0390888E 03	0.	-6.4800118E 05	0.
201.90	5.7835345E 01	0.	-2.4837885E 03	0.	-6.8417711E 05	0.
214.00	3.9446851E 01	0.	-1.7417328E 03	0.	-7.1128346E 05	0.
214.00	1.5276367E 02	0.	-7.5656799E 03	0.	-7.1261947E 05	0.
286.00	4.1502017E 01	0.	-3.4975714E 03	0.	-1.0952745E 06	0.
286.00	4.1502017E 01	0.	-3.4975714E 03	0.	-1.0952745E 06	0.
296.50	3.3778811E 01	0.	-3.1159246E 03	0.	-1.0996403E 06	0.
296.50	3.3778811E 01	0.	-3.1159246E 03	0.	-1.0996403E 06	0.
315.89	3.7767153E 01	0.	3.9297952E 03	0.	-1.1294179E 06	0.
315.89	3.7767153E 01	0.	3.9297952E 03	0.	-1.1294179E 06	0.
328.10	4.0599285E 01	0.	4.5964118E 03	0.	-1.0488440E 06	0.
341.00	4.3639673E 01	0.	4.7977206E 03	0.	-1.0488440E 06	0.
366.00	5.3766548E 01	0.	4.9478354E 03	0.	-9.9148123E 05	0.
392.12	5.6146774E 01	0.	5.2768413E 03	0.	-9.2876843E 05	0.
392.12	5.6146774E 01	0.	5.2768413E 03	0.	-8.0040116E 05	0.
407.00	5.7283165E 01	0.	5.4091516E 03	0.	-6.6102635E 05	0.
419.00	5.9266107E 01	0.	5.4091516E 03	0.	-6.6102635E 05	0.
429.23	6.0293315E 01	0.	5.4766563E 03	0.	-5.8000154E 05	0.
429.23	6.0293315E 01	0.	5.4766563E 03	0.	-5.8000154E 05	0.
446.55	5.9965980E 01	0.	5.5455318E 03	0.	-5.1399610E 05	0.
455.22	5.9870002E 01	0.	5.5914696E 03	0.	-4.5705221E 05	0.
455.22	2.7597952E-01	0.	1.1075319E 04	0.	-4.5705221E 05	0.
470.80	1.2166977E-01	0.	1.1123742E 04	0.	-2.6484279E 05	0.
486.39	2.7547359E-02	0.	1.141869E 04	0.	-1.6833793E 05	0.
486.39	2.7547359E-02	0.	5.4136499E 03	0.	-1.6833793E 05	0.
500.00	2.7547359E-02	0.	5.4508974E 03	0.	-8.4265050E 04	0.
500.00	9.0885162E-04	0.	-3.2951782E 01	0.	3.9992969E 02	0.
520.00	-6.0272217E-04	0.	-1.2912903E 01	0.	1.2799219E 02	0.
520.00	-6.0272217E-04	0.	-2.5024414E-03	0.	-1.2343750E 00	0.

Table 4.29 Fuselage Loading Symmetric Flight Maneuver

FUSELAGE SHEAR AND MOMENT PROGRAM - JOB NUMBER 1105 - 1/9/63

SYMMETRIC FLIGHT CONDITION F-8

OUTPUT

F.S.	FX	FY	FZ	MX	MY	MZ
-70.00	0.	0.	0.	0.	0.	0.
0.	6.0103105E-01	0.	-4.6520727E-01	0.	0.	0.
20.00	1.2946602E 00	0.	-2.2228743E 02	0.	-3.7276775E 01	0.
35.20	1.6039435E 00	0.	-6.9382595E 02	0.	-1.5311075E 03	0.
47.00	4.5290734E 00	0.	-1.2331754E 03	0.	-8.1618599E 03	0.
59.00	9.0268537E 00	0.	-1.9234803E 03	0.	-1.9473796E 04	0.
71.00	1.3234804E 01	0.	-3.0749201E 03	0.	-3.8482044E 04	0.
82.60	1.6970507E 01	0.	-4.9139640E 03	0.	-6.7759617E 04	0.
91.00	1.9936965E 01	0.	-6.4995340E 03	0.	-1.1357524E 05	0.
110.00	2.8107913E 01	0.	-7.6548805E 03	0.	-1.6151877E 05	0.
110.00	2.8107913E 01	0.	-7.6548805E 03	0.	-3.0490109E 05	0.
122.50	3.3365104E 01	0.	-5.4179872E 03	0.	-3.0490109E 05	0.
136.50	4.0984216E 01	0.	-4.0154887E 03	0.	-3.8940180E 05	0.
136.50	4.0984216E 01	0.	-4.0154887E 03	0.	-4.5073465E 05	0.
150.00	4.3691816E 01	0.	-3.8496980E 03	0.	-4.5073465E 05	0.
165.20	5.1918879E 01	0.	-3.8818157E 03	0.	-5.0364823E 05	0.
177.20	6.1025192E 01	0.	-3.6438308E 03	0.	-5.6295282E 05	0.
188.90	6.3919252E 01	0.	-3.1862295E 03	0.	-6.0865501E 05	0.
201.90	6.1518207E 01	0.	-2.7010225E 03	0.	-6.4938038E 05	0.
214.00	4.4161122E 01	0.	-2.0491670E 03	0.	-6.8795992E 05	0.
214.00	1.6673740E 02	0.	-7.7327049E 03	0.	-7.1809521E 05	0.
286.00	5.9496019E 01	0.	-3.6776030E 03	0.	-7.1954039E 05	0.
286.00	5.9496019E 01	0.	-3.6776030E 03	0.	-1.1154822E 06	0.
287.00	5.3478881E 01	0.	-3.2815492E 03	0.	-1.1154822E 06	0.
296.50	5.2250779E 01	0.	-2.7190386E 03	0.	-1.1200477E 06	0.
296.50	5.2250779E 01	0.	-2.7190386E 03	0.	-1.1514110E 06	0.
315.89	5.7679942E 01	0.	3.8503060E 03	0.	-1.1514110E 06	0.
315.89	5.7679942E 01	0.	4.5087949E 03	0.	-1.0724241E 06	0.
315.89	5.7679942E 01	0.	4.5087949E 03	0.	-1.0724241E 06	0.
328.10	6.0406759E 01	0.	4.7126483E 03	0.	-1.0161549E 06	0.
341.00	6.0159951E 01	0.	4.9122514E 03	0.	-9.5436149E 05	0.
366.00	5.4502237E 01	0.	5.5626010E 03	0.	-8.2374098E 05	0.
392.12	5.4576594E 01	0.	5.7509770E 03	0.	-6.7558542E 05	0.
392.12	5.4576594E 01	0.	5.7509770E 03	0.	-6.7558542E 05	0.
407.00	5.5866885E 01	0.	5.8175070E 03	0.	-5.8948390E 05	0.
419.00	5.8000575E 01	0.	5.8854247E 03	0.	-5.1939475E 05	0.
429.23	5.9126194E 01	0.	5.9307376E 03	0.	-4.5897821E 05	0.
429.23	5.9126194E 01	0.	1.1293691E 04	0.	-4.5897821E 05	0.
446.55	5.8899338E 01	0.	1.1341476E 04	0.	-2.6299170E 05	0.
455.22	5.8840022E 01	0.	1.1359372E 04	0.	-1.645980E 05	0.
455.22	6.6205025E-02	0.	5.2542252E 03	0.	-1.645980E 05	0.
470.80	-9.4876289E-03	0.	5.2935897E 03	0.	-8.2394038E 04	0.
486.39	-3.2666683E-02	0.	5.3303866E 03	0.	3.9603320E 02	0.
486.39	-3.2666683E-02	0.	-3.2566955E 01	0.	3.9603320E 02	0.
500.00	-2.1854877E-02	0.	-1.2764404E 01	0.	1.2716016E 02	0.
520.00	-3.7097931E-04	0.	-7.3242187E-04	0.	-5.0781250E-01	0.

Table 4.30 XV-5A Fuselage Loading Symmetric Flight Maneuver

FUSELAGE SHEAR AND MOMENT PROGRAM - JOE NUMBER 1105 - 22 APRIL 63

SYMMETRIC FLIGHT CONDITION F-8P

OUTPUT

F.S.	FX	FY	FZ	MX	MY	MZ
-70.00	0.00	0.00	-0.6520727E-01	0.00	-0.00	0.00
0.00	6.013105E-01	0.00	-2.342117E-04	0.00	-3.7276775E-01	0.00
20.00	1.2946602E-00	0.00	-7.1530537E-04	0.00	-1.6424544E-03	0.00
35.00	1.6039435E-00	0.00	-1.2615722E-03	0.00	-6.5202760E-03	0.00
47.00	4.5230734E-00	0.00	-1.89584315E-03	0.00	-2.0333974E-04	0.00
59.00	9.3289537E-00	0.00	-5.1159599E-03	0.00	-3.9522845E-04	0.00
71.00	1.3234800E-01	0.00	-4.8604584E-03	0.00	-6.9236846E-04	0.00
82.60	1.9970507E-01	0.00	-6.8497075E-03	0.00	-1.1558101E-03	0.00
91.00	1.9936968E-01	0.00	-7.7156152E-03	0.00	-1.6333041E-03	0.00
100.00	2.6137919E-01	0.00	-7.7196152E-03	0.00	-3.0637794E-03	0.00
110.00	2.6137919E-01	0.00	-5.4976960E-03	0.00	-3.0637794E-03	0.00
120.00	3.2300144E-01	0.00	-4.1115716E-03	0.00	-3.9337965E-03	0.00
136.00	4.0984216E-01	0.00	-3.9597300E-03	0.00	-4.0564483E-03	0.00
150.00	4.3661516E-01	0.00	-3.9597300E-03	0.00	-4.5634834E-03	0.00
165.00	5.1918578E-01	0.00	-3.9597300E-03	0.00	-5.1056124E-03	0.00
177.00	6.1031922E-01	0.00	-3.7599773E-03	0.00	-5.7167231E-03	0.00
188.00	6.9432522E-01	0.00	-3.3129579E-03	0.00	-6.1872491E-03	0.00
201.00	6.1932075E-01	0.00	-2.8401178E-03	0.00	-6.6066692E-03	0.00
214.00	4.4161123E-01	0.00	-2.2001238E-03	0.00	-7.0117350E-03	0.00
224.00	9.4575243E-02	0.00	-1.8278882E-04	0.00	-7.3966427E-03	0.00
236.00	-1.0521166E-03	0.00	-6.2716434E-03	0.00	-6.9573535E-03	0.00
247.00	-2.3172094E-02	0.00	-1.4255665E-03	0.00	-1.2784475E-06	0.00
259.00	-2.3772094E-02	0.00	-1.0340116E-03	0.00	-1.2759216E-06	0.00
276.00	-2.3649066E-02	0.00	-4.7462834E-02	0.00	-1.2782399E-06	0.00
296.00	-2.3649066E-02	0.00	5.7201845E-03	0.00	-1.2882674E-06	0.00
315.00	-2.3649066E-02	0.00	6.3744398E-03	0.00	-1.2882674E-06	0.00
335.00	-2.3321922E-02	0.00	5.3744398E-03	0.00	-1.1730695E-06	0.00
358.10	-2.3321922E-02	0.00	6.5772035E-03	0.00	-1.1730695E-06	0.00
381.00	-2.3133991E-02	0.00	6.7766171E-03	0.00	-1.0940271E-06	0.00
366.00	-2.3669762E-02	0.00	7.4269667E-03	0.00	-1.0081849E-06	0.00
392.12	-2.3669762E-02	0.00	7.615427E-03	0.00	-6.3095521E-03	0.00
392.12	-6.2737262E-02	0.00	5.3249667E-03	0.00	-6.3410271E-03	0.00
407.00	-6.2578997E-02	0.00	5.3914267E-03	0.00	-6.3242216E-03	0.00
419.00	-6.2355233E-02	0.00	5.4594144E-03	0.00	-5.5265995E-03	0.00
429.23	-5.2227655E-02	0.00	5.5047272E-03	0.00	-4.6768296E-03	0.00
446.55	-5.2227655E-02	0.00	1.0582836E-04	0.00	-4.3162426E-03	0.00
455.22	-5.2227655E-02	0.00	1.0630621E-04	0.00	-2.4794933E-03	0.00
455.22	5.2227655E-02	0.00	1.064817E-04	0.00	-1.5572052E-03	0.00
470.00	5.9659132E-03	0.00	4.96593612E-03	0.00	-1.5572052E-03	0.00
486.39	3.274745E-02	0.00	5.0087456E-03	0.00	-7.7952903E-04	0.00
486.39	3.274746E-02	0.00	5.0455426E-03	0.00	3.9559707E-02	0.00
500.00	-2.1935940E-02	0.00	-3.2566467E-01	0.00	3.9559707E-02	0.00
520.00	-1.5240155E-04	0.00	-1.2765916E-01	0.00	1.2753125E-02	0.00
520.00	-1.5240155E-04	0.00	-2.44414862E-04	0.00	-4.3750000E-01	0.00

Table 4.31 Fuselage Loading Symmetric Flight Maneuver

FUSELAGE SHEAR AND MOMENT PROGRAM - JOB NUMBER 1105 - 1/9/63

SYMMETRIC FLIGHT CONDITION F-12

OUTPUT

F.S.	FX	FY	FZ	MX	MY	MZ
-70.00	0.	0.	-0.	0.	-0.	0.
0.	1.2020621E 00	0.	-9.3041455E-01	0.	-7.4553549E 01	0.
20.00	2.5893204E 00	0.	-2.5801223E 02	0.	-2.0636147E 03	0.
35.20	3.2078871E 00	0.	-6.8782344E 02	0.	-9.0163835E 03	0.
47.00	9.0581467E 00	0.	-1.1408084E 03	0.	-1.9883786E 04	0.
59.00	1.8053707E 01	0.	-1.6883762E 03	0.	-3.7189386E 04	0.
71.00	2.6469607E 01	0.	-2.5866476E 03	0.	-6.2367391E 04	0.
82.60	3.3941014E 01	0.	-4.0053895E 03	0.	-1.0034148E 05	0.
91.00	3.9873929E 01	0.	-5.2235120E 03	0.	-1.3922183E 05	0.
110.00	5.6215827E 01	0.	-6.1254411E 03	0.	-2.5415289E 05	0.
110.00	5.6215827E 01	0.	-6.1254411E 03	0.	-2.5415289E 05	0.
122.50	6.6730207E 01	0.	-4.4594757E 03	0.	-3.2273888E 05	0.
136.50	8.1968431E 01	0.	-3.2908675E 03	0.	-3.7452110E 05	0.
136.50	8.1968431E 01	0.	-3.2908675E 03	0.	-3.7452110E 05	0.
150.00	8.7363632E 01	0.	-2.9088996E 03	0.	-4.1631159E 05	0.
165.20	1.0383776E 02	0.	-2.7842813E 03	0.	-4.6056597E 05	0.
177.20	1.2205038E 02	0.	-2.3680083E 03	0.	-4.9220173E 05	0.
188.90	1.2783850E 02	0.	-1.7714538E 03	0.	-5.1764765E 05	0.
201.90	1.2303641E 02	0.	-1.3311884E 03	0.	-5.3823620E 05	0.
214.00	8.832244E 01	0.	-6.6827998E 02	0.	-5.5300512E 05	0.
214.00	3.3347481E 02	0.	-8.9142618E 03	0.	-5.5589546E 05	0.
286.00	1.1899204E 02	0.	-4.0521202E 03	0.	-1.0225908E 06	0.
286.00	1.1899204E 02	0.	-4.0521202E 03	0.	-1.0225908E 06	0.
287.00	1.0695776E 02	0.	-3.2817394E 03	0.	-1.0284241E 06	0.
296.50	1.0450156E 02	0.	-2.3332471E 03	0.	-1.0608587E 06	0.
296.50	1.0450156E 02	0.	-2.3332471E 03	0.	-1.0608587E 06	0.
315.89	1.1535988E 02	0.	3.2196257E 03	0.	-1.0132314E 06	0.
315.89	1.1535988E 02	0.	3.2196257E 03	0.	-1.0132314E 06	0.
328.10	1.2081352E 02	0.	3.5437518E 03	0.	-1.0132314E 06	0.
341.00	1.2031990E 02	0.	3.8940609E 03	0.	-9.7204515E 05	0.
366.00	1.0900447E 02	0.	5.1532682E 03	0.	-9.2467635E 05	0.
392.12	1.0915319E 02	0.	5.5191535E 03	0.	-8.1230396E 05	0.
392.12	1.0915319E 02	0.	5.5191535E 03	0.	-6.7216426E 05	0.
407.00	1.1173377E 02	0.	5.6522135E 03	0.	-5.8698433E 05	0.
419.00	1.1600115E 02	0.	5.7880487E 03	0.	-5.2060777E 05	0.
429.23	1.1825239E 02	0.	5.8786746E 03	0.	-4.6097150E 05	0.
429.23	1.1825239E 02	0.	5.8786746E 03	0.	-4.6097150E 05	0.
446.55	1.1779868E 02	0.	1.1425066E 03	0.	-4.6037150E 05	0.
455.22	1.1768004E 02	0.	1.1425624E 04	0.	-2.6397204E 05	0.
455.22	1.3241005E-01	0.	1.1461416E 04	0.	-1.6475192E 05	0.
470.80	-1.8975258E-02	0.	5.2339205E 03	0.	-1.6479192E 05	0.
486.39	-6.5333366E-02	0.	5.3126494E 03	0.	-8.2561312E 04	0.
486.39	-6.5333366E-02	0.	5.3862433E 03	0.	7.9079667E 02	0.
500.00	-4.3709755E-02	0.	-6.5136597E 01	0.	7.9079667E 02	0.
500.00	-4.3709755E-02	0.	-2.5531494E 01	0.	2.5587500E 02	0.
520.00	-7.4195862E-04	0.	-4.1503906E-03	0.	-1.9843750E 00	0.

Table-4.32 Fuselage Loading Symmetric Flight Maneuver

FUSELAGE SHEAR AND MOMENT PROGRAM - JOB NUMBER 1105 - 22 APRIL 63

SYMMETRIC FLIGHT CONDITION F-12P

OUTPUT

F.S.	FX	FY	FZ	MX	MY	MZ
-70.00	0.	0.	-0.	0.	-0.	0.
0.	1.2020621E 00	0.	-9.3041455E-01	0.	-7.4553549E 01	0.
20.00	2.5892204E 00	0.	-2.6880051E 02	0.	-2.1643538E 03	0.
35.20	3.2078871E 00	0.	-7.0725622E 02	0.	-9.3478892E 03	0.
47.00	9.0581467E 00	0.	-1.1664992E 03	0.	-2.0481061E 04	0.
59.00	1.8053707E 01	0.	-1.7199962E 03	0.	-3.8131012E 04	0.
71.00	2.6469607E 01	0.	-2.6235965E 03	0.	-6.3721942E 04	0.
82.60	3.3941014E 01	0.	-4.0474508E 03	0.	-1.0215609E 05	0.
91.00	3.9873929E 01	0.	-5.2689008E 03	0.	-1.4140361E 05	0.
110.00	5.6215827E 01	0.	-6.1840028E 03	0.	-2.5729830E 05	0.
110.00	5.6215827E 01	0.	-6.1840028E 03	0.	-2.5729830E 05	0.
122.50	6.6730207E 01	0.	-4.5315870E 03	0.	-3.2669938E 05	0.
136.50	8.1968431E 01	0.	-3.3781561E 03	0.	-3.7959967E 05	0.
136.50	8.1968431E 01	0.	-3.3781561E 03	0.	-3.7959967E 05	0.
150.00	8.7363632E 01	0.	-3.0084484E 03	0.	-4.2265612E 05	0.
165.20	1.0383776E 02	0.	-2.8858732E 03	0.	-4.6845438E 05	0.
177.20	1.2205036E 02	0.	-2.4730868E 03	0.	-5.0130825E 05	0.
188.90	1.2783850E 02	0.	-1.8861067E 03	0.	-5.2803949E 05	0.
201.90	1.2303641E 02	0.	-1.4570305E 03	0.	-5.5019047E 05	0.
214.00	8.8322244E 01	0.	-8.0485409E 02	0.	-5.6654760E 05	0.
214.00	-9.0134263E 02	0.	-1.1574352E 04	0.	-5.2997050E 05	0.
286.00	-1.1158234E 03	0.	-6.7555110E 03	0.	-1.1913094E 06	0.
366.00	-2.0645221E 02	0.	-1.9828610E 03	0.	-1.1870004E 06	0.
37.00	-2.1848649E 02	0.	-1.2128230E 03	0.	-1.1907646E 06	0.
36.50	-2.2094270E 02	0.	-2.6716022E 02	0.	-1.2035592E 06	0.
36.50	-2.2094270E 02	0.	3.9123705E 03	0.	-1.2035592E 06	0.
315.89	-2.1008437E 02	0.	4.9857312E 03	0.	-1.1216545E 06	0.
315.89	-2.1008437E 02	0.	4.9857312E 03	0.	-1.1216545E 06	0.
328.10	-2.0463074E 02	0.	5.3088713E 03	0.	-1.0589117E 06	0.
341.00	-2.0512435E 02	0.	6.9182162E 03	0.	-9.8877451E 05	0.
366.00	-2.1643978E 02	0.	7.2841014E 03	0.	-8.3227841E 05	0.
392.12	-2.1629107E 02	0.	5.1651975E 03	0.	-6.4603854E 05	0.
392.12	-2.1629107E 02	0.	7.2841014E 03	0.	-6.4603854E 05	0.
407.00	-5.7493448E 02	0.	5.2982575E 03	0.	-6.4470108E 05	0.
419.00	-5.7066709E 02	0.	5.4340928E 03	0.	-5.6678528E 05	0.
429.23	-5.6841586E 02	0.	5.5247186E 03	0.	-5.0265923E 05	0.
429.23	-5.6841586E 02	0.	1.0886400E 04	0.	-4.4664369E 05	0.
446.55	-5.6886957E 02	0.	1.0981970E 04	0.	-4.4664369E 05	0.
455.22	-5.6898820E 02	0.	1.1017761E 04	0.	-2.5732793E 05	0.
455.22	1.323948E-01	0.	5.1442266E 03	0.	-1.6199436E 05	0.
470.80	-1.9049644E-02	0.	5.2229556E 03	0.	-1.6199436E 05	0.
486.39	-6.5407753E-02	0.	5.2965496E 03	0.	-8.1161358E 04	0.
486.39	-6.5407753E-02	0.	-6.5131958E 01	0.	7.9203125E 02	0.
500.00	-4.3784142E-02	0.	-2.5526855E 01	0.	7.9203125E 02	0.
520.00	-8.1634521E-04	0.	4.8828125E-04	0.	2.5753125E 02	0.
520.00	-8.1634521E-04	0.	4.8828125E-04	0.	-5.0000000E-01	0.

Table 4.33 Fuselage Loading Symmetric Flight Maneuver

FUSELAGE SHEAR AND MOMENT PROGRAM - JOB NUMBER 1105 - 1/9/53

SYMMETRIC FLIGHT CONDITION F-13

OUTPUT

F.S.	FX	FY	FZ	MX	MY	MZ
-70.00	0.	0.	0.	0.	0.	0.
0.	0.	0.	-2.643999E 01	0.	-7.7692391E 02	0.
20.00	0.	0.	1.6623657E 02	0.	1.9769000E 02	0.
35.20	0.	0.	3.3990887E 02	0.	4.0566853E 03	0.
47.00	0.	0.	3.1792403E 02	0.	7.9212971E 03	0.
59.00	0.	0.	1.0283812E 02	0.	1.1699761E 04	0.
71.00	0.	0.	-1.1341125E 02	0.	1.0687356E 04	0.
82.60	0.	0.	-3.5290683E 02	0.	8.1795795E 03	0.
91.00	0.	0.	-5.4018074E 02	0.	4.5213633E 03	0.
110.00	0.	0.	-1.0010382E 03	0.	-9.9280410E 03	0.
122.50	0.	0.	-1.0401671E 03	0.	-2.2911573E 04	0.
136.50	0.	0.	-1.8899248E 03	0.	-4.0322076E 04	0.
136.50	0.	0.	-1.8899248E 03	0.	-4.0322076E 04	0.
150.00	0.	0.	-3.554247E 03	0.	-8.141727E 04	0.
165.20	0.	0.	-4.1649709E 03	0.	-1.3922813E 05	0.
177.20	0.	0.	-5.4036172E 03	0.	-1.9638520E 05	0.
188.90	0.	0.	-6.7418465E 03	0.	-2.6718524E 05	0.
201.90	0.	0.	-7.2637397E 03	0.	-3.5901406E 05	0.
214.00	0.	0.	-8.2093267E 03	0.	-4.5043019E 05	0.
214.00	0.	0.	6.3353048E 03	0.	-4.5043019E 05	0.
286.00	-0.	0.	1.1971932E 03	0.	-2.6777145E 05	0.
286.00	-0.	0.	1.1971932E 03	0.	-2.6777145E 05	0.
287.00	-0.	0.	-2.7430542E 01	0.	-2.6499978E 05	0.
296.50	-0.	0.	-1.3628551E 03	0.	-2.6289940E 05	0.
296.50	-0.	0.	3.8210381E 03	0.	-2.6289940E 05	0.
315.89	-0.	0.	2.3849289E 03	0.	-2.3758248E 05	0.
315.89	-0.	0.	2.3849289E 03	0.	-2.3758248E 05	0.
328.10	-0.	0.	2.0054101E 03	0.	-2.0659198E 05	0.
341.00	-0.	0.	1.7153191E 03	0.	-1.0500439E 05	0.
366.00	-0.	0.	1.1514726E 03	0.	-6.1471812E 04	0.
392.12	-0.	0.	8.3679394E 02	0.	-1.0603234E 05	0.
392.12	-0.	0.	8.3679394E 02	0.	-1.0603234E 05	0.
407.00	-0.	0.	6.7276489E 02	0.	-1.1315290E 05	0.
419.00	-0.	0.	5.1104712E 02	0.	-1.1699359E 05	0.
429.23	-0.	0.	4.0607007E 02	0.	-6.7722750E 04	0.
429.23	-0.	0.	1.0565226E 03	0.	-6.7722750E 04	0.
446.55	-0.	0.	9.5080932E 02	0.	-1.0473900E 05	0.
455.22	-0.	0.	9.1240645E 02	0.	-5.3155500E 04	0.
455.22	-0.	0.	8.7334075E 02	0.	-5.3155500E 04	0.
470.80	-0.	0.	7.8938134E 02	0.	-4.0240000E 04	0.
486.39	-0.	0.	7.1380200E 02	0.	-4.0959499E 04	0.
486.39	-0.	0.	6.3349449E 01	0.	-4.0959499E 04	0.
500.00	-0.	0.	2.4234131E 01	0.	-2.4243750E 02	0.
520.00	-0.	0.	2.9296875E-03	0.	9.3750000E-01	0.

Table 4.34 Fuselage Loading Symmetric Flight Maneuver

FUSELAGE SHEAR AND MOMENT PROGRAM - JOB NUMBER 1105 - 1/22/63

SYMMETRIC FLIGHT CONDITION F-14

OUTPUT

F.S.	FX	FY	FZ	MX	MY	MZ
-70.00	-0.	0.	0.	0.	0.	0.
0.	-1.1534E 00	0.	-1.2597887E 01	0.	-3.2406887E 02	0.
20.00	-2.4741586E 00	0.	1.8310146E 02	0.	1.02825226E 03	0.
35.20	-3.0630460E 00	0.	3.5233647E 02	0.	5.1315212E 03	0.
47.00	-8.6339437E 00	0.	3.8143653E 02	0.	9.6567736E 03	0.
59.00	-1.7017183E 01	0.	2.7791295E 02	0.	1.4696283E 04	0.
71.00	-2.4916925E 01	0.	1.5492726E 02	0.	1.6949722E 04	0.
82.60	-3.1992073E 01	0.	-1.5951263E 01	0.	1.8093870E 04	0.
91.00	-3.7656057E 01	0.	-1.5818512E 02	0.	1.7598945E 04	0.
110.00	-5.2828441E 01	0.	-4.5949931E 02	0.	1.2252724E 04	0.
122.50	-6.2463779E 01	0.	-4.5949931E 02	0.	1.2252724E 04	0.
136.50	-7.5297022E 01	0.	-4.0806762E 02	0.	7.1186308E 03	0.
150.00	-7.7112916E 01	0.	-1.0079439E 03	0.	6.3377929E 02	0.
165.20	-9.2275319E 01	0.	-2.3132373E 03	0.	-2.3878717E 04	0.
177.20	-1.030766E 02	0.	-2.8035858E 03	0.	-6.1545421E 04	0.
188.90	-1.1774907E 02	0.	-3.859963E 03	0.	-1.0065098E 05	0.
201.90	-1.1567069E 02	0.	-5.0275415E 03	0.	-1.5144383E 05	0.
214.00	-7.8893701E 01	0.	-5.4884811E 03	0.	-2.1994981E 05	0.
214.00	-3.052734E 02	0.	-6.3769974E 03	0.	-2.8773946E 05	0.
286.00	-8.3004034E 01	0.	7.3134931E 03	0.	-2.8506745E 05	0.
287.00	-7.1259905E 01	0.	2.0278286E 03	0.	-1.7836937E 04	0.
296.50	-6.7557621E 01	0.	6.8683349E 02	0.	-1.3277625E 04	0.
315.89	-7.5534305E 01	0.	-8.1358068E 02	0.	-3.8162500E 03	0.
315.89	-7.5534305E 01	0.	3.1505090E 02	0.	-3.8162500E 03	0.
328.10	-8.1198570E 01	0.	1.4929073E 03	0.	1.0131953E 04	0.
341.00	-8.7279346E 01	0.	1.0432974E 03	0.	2.9787750E 04	0.
366.00	-1.0753310E 02	0.	6.9091138E 02	0.	1.1440883E 05	0.
392.12	-1.1229355E 02	0.	-6.5466552E 01	0.	1.2964206E 05	0.
397.00	-1.1229355E 02	0.	-4.6738012E 02	0.	5.6548281E 04	0.
407.00	-1.1456633E 02	0.	-6.6738012E 02	0.	5.6548281E 04	0.
419.00	-1.1833222E 02	0.	-6.8298340E 02	0.	3.0718562E 04	0.
429.23	-1.2058663E 02	0.	-1.0438320E 03	0.	1.1085000E 04	0.
429.23	-1.2058663E 02	0.	-1.6902894E 03	0.	4.3209844E 04	0.
446.55	-1.1993196E 02	0.	-1.833362E 03	0.	4.3209844E 04	0.
455.22	-1.1974000E 02	0.	-1.8931728E 03	0.	-3.8569905E 04	0.
455.22	-5.5195904E -01	0.	-3.1746133E 02	0.	-1.3712187E 04	0.
470.80	-2.4333954E -01	0.	-4.3842407E 02	0.	-1.3712187E 04	0.
486.39	-5.5094719E -02	0.	-5.4996386E 02	0.	-1.9664250E 04	0.
486.39	-5.5094719E -02	0.	9.6493484E 01	0.	-3.9064437E 04	0.
500.00	-1.8177032E -03	0.	3.7505127E 01	0.	-3.7581250E 02	0.
520.00	1.2054443E -03	0.	1.4648437E -03	0.	9.3750000E -01	0.

Table 4.35 Fuselage Loading Symmetric Flight Maneuver

SYMMETRIC FLIGHT CONDITION F-16

OUTPUT

F.S.	FX	FY	FZ	MX	MY	MZ
-70.00	-0.	0.	0.	0.	0.	0.
0.	-1.2020621E 00	0.	-1.2289585E 01	0.	-3.1390841E 02	0.
20.00	-2.5893204E 00	0.	1.7985295E 02	0.	1.0170951E 03	0.
35.20	-3.2078871E 00	0.	3.4618427E 02	0.	5.0048869E 03	0.
47.00	-9.0581467E 00	0.	3.7509201E 02	0.	9.5057346E 03	0.
59.00	-1.8053707E 01	0.	2.7381474E 02	0.	1.4475827E 04	0.
71.00	-2.6469607E 01	0.	1.5374231E 02	0.	1.6715107E 04	0.
82.60	-3.9841014E 01	0.	-1.2927856E 01	0.	1.7873495E 04	0.
91.00	-3.9873929E 01	0.	-1.5168809E 02	0.	1.87422751E 04	0.
110.00	-5.6215827E 01	0.	-4.4770324E 02	0.	1.42273592E 04	0.
122.50	-6.6730207E 01	0.	-3.9960348E 02	0.	1.22273592E 04	0.
136.50	-8.1968431E 01	0.	-9.9357693E 02	0.	7.2804560E 03	0.
136.50	-8.1968431E 01	0.	-9.9357693E 02	0.	9.2964648E 02	0.
150.00	-8.7363632E 01	0.	-2.2816133E 03	0.	9.2964648E 02	0.
165.20	-1.0383776E 02	0.	-2.7393459E 03	0.	-2.3220950E 04	0.
177.20	-1.2205038E 02	0.	-3.5443867E 03	0.	-6.0325937E 04	0.
188.90	-1.2783850E 02	0.	-4.3890582E 03	0.	-9.7257472E 04	0.
201.90	-1.2303641E 02	0.	-4.5447673E 03	0.	-1.4251001E 05	0.
214.00	-8.8322244E 01	0.	-5.0552940E 03	0.	-2.0058492E 05	0.
286.00	-1.1899204E 02	0.	8.0018302E 03	0.	-2.5501738E 05	0.
286.00	-1.1899204E 02	0.	2.7093943E 03	0.	-2.5212704E 05	0.
287.00	-1.0695776E 02	0.	2.7093943E 03	0.	6.9470953E 04	0.
296.50	-1.0450156E 02	0.	1.3026542E 03	0.	6.9470953E 04	0.
315.89	-1.1535988E 02	0.	-2.2549853E 02	0.	7.4790992E 04	0.
315.89	-1.1535988E 02	0.	3.7381223E 03	0.	9.0162413E 04	0.
328.10	-1.2081352E 02	0.	2.0966001E 03	0.	9.0162413E 04	0.
341.00	-1.2031990E 02	0.	1.6342720E 03	0.	1.1634151E 05	0.
366.00	-1.0900447E 02	0.	1.1061714E 03	0.	1.4332459E 05	0.
392.12	-1.0915319E 02	0.	-7.5599072E 02	0.	2.3340323E 05	0.
407.00	-1.1173377E 02	0.	-1.3487642E 03	0.	2.4741619E 05	0.
419.00	-1.1600115E 02	0.	-1.5624927E 03	0.	1.5303747E 05	0.
429.23	-1.1825239E 02	0.	-1.9202864E 03	0.	1.5303747E 05	0.
429.23	-1.1825239E 02	0.	-3.2749634E 03	0.	1.1444034E 05	0.
446.55	-1.1779868E 02	0.	-3.4218210E 03	0.	8.4467312E 04	0.
455.22	-1.1768004E 02	0.	-3.4762265E 03	0.	1.0681325E 05	0.
470.80	-1.3241005E-01	0.	-1.0282119E 03	0.	1.0681325E 05	0.
486.39	6.5333366E-02	0.	-1.1482151E 03	0.	-1.4461718E 03	0.
486.39	6.5333366E-02	0.	-1.2588926E 03	0.	8.9250312E 03	0.
500.00	4.3709755E-02	0.	3.7234863E 01	0.	8.9250312E 03	0.
520.00	7.4195862E-04	0.	1.9531250E-03	0.	-3.0931875E 03	0.
					-3.8326687E 04	0.
					-3.7306250E 02	0.
					1.1875000E 02	0.

Table 4.36 Fuselage Loading Symmetric Flight Maneuver

FUSELAGE SHEAR AND MOMENT PROGRAM - JOB NUMBER 1105 - 19 APRIL 63

SYMMETRIC FLIGHT CONDITION F-16P

OUTPUT

F.S.	FX	FY	FZ	MX	MY	MZ
-70.00	-0.	0.	0.	0.	0.	0.
0.	-1.2020621E 00	0.	-1.2289595E 01	0.	0.	0.
20.00	-2.5893204E 00	0.	1.7475113E 02	0.	-3.1390841E 02	0.
35.00	-3.078871E 00	0.	3.3612114E 02	0.	9.7581048E 02	0.
47.00	-9.0581467E 00	0.	3.6104161E 02	0.	4.8927091E 03	0.
59.00	-1.8053707E 01	0.	2.5559693E 02	0.	9.2073947E 03	0.
71.00	-2.6469677E 01	0.	1.3124998E 02	0.	1.3983966E 04	0.
82.60	-3.3941014E 01	0.	-3.9660614E 01	0.	1.5979140E 04	0.
91.00	-3.9873929E 01	0.	-1.8144903E 02	0.	1.6852091E 04	0.
110.00	-5.6215827E 01	0.	-4.8483019E 02	0.	1.6163667E 04	0.
110.00	-5.6215827E 01	0.	-4.8483019E 02	0.	1.0378686E 04	0.
122.50	-6.5730207E 01	0.	-4.4165245E 02	0.	1.0378686E 04	0.
136.50	-8.1968431E 01	0.	-1.0407524E 03	0.	4.8907187E 03	0.
136.50	-8.1968431E 01	0.	-1.0407524E 03	0.	-2.0854453E 03	0.
150.00	-8.7363632E 01	0.	-2.3331265E 03	0.	-2.0854453E 03	0.
165.20	-1.0383776E 02	0.	-2.7950704E 03	0.	-2.6902916E 04	0.
177.20	-1.2205038E 02	0.	-3.6040156E 03	0.	-6.4823624E 04	0.
198.90	-1.2783850E 02	0.	-4.4555469E 03	0.	-1.0244439E 05	0.
201.90	-1.2303641E 02	0.	-4.6188556E 03	0.	-1.4843421E 05	0.
214.00	-8.8322244E 01	0.	-5.1356043E 03	0.	-2.0742356E 05	0.
214.00	-1.8782721E 03	0.	5.2086397E 03	0.	-2.6279126E 05	0.
286.00	-1.6637894E 03	0.	-1.1274890E 02	0.	-2.1857010E 05	0.
286.00	-5.3123498E 02	0.	4.5017201E 03	0.	-9.8061952E 04	0.
287.00	-5.1920071E 02	0.	3.0946633E 03	0.	-8.9294038E 04	0.
296.50	-5.1674451E 02	0.	1.5638476E 03	0.	-8.2181796E 04	0.
315.89	-5.2760283E 02	0.	5.3456832E 03	0.	-4.9799507E 04	0.
315.89	-5.2760283E 02	0.	3.7008990E 03	0.	-4.9799507E 04	0.
328.10	-5.3305646E 02	0.	3.7008990E 03	0.	8.3110781E 03	0.
341.00	-5.3256285E 02	0.	3.2377483E 03	0.	8.3110781E 03	0.
366.00	-5.2124742E 02	0.	2.7090293E 03	0.	5.4788156E 04	0.
392.12	-5.2139613E 02	0.	8.4189672E 02	0.	1.6404583E 05	0.
392.12	-8.1058413E 02	0.	2.4912329E 02	0.	2.1786945E 05	0.
407.00	-8.1316471E 02	0.	-1.4472247E 03	0.	1.6659794E 05	0.
419.00	-8.1743208E 02	0.	-1.6609531E 03	0.	1.6708059E 05	0.
429.23	-8.1968333E 02	0.	-1.8765608E 03	0.	1.2736950E 05	0.
429.23	-8.1968333E 02	0.	-2.0187468E 03	0.	9.6430750E 04	0.
446.55	-8.1922961E 02	0.	-3.4994919E 03	0.	1.1690509E 05	0.
455.22	-8.1911098E 02	0.	-3.6463495E 03	0.	1.1690509E 05	0.
455.22	-1.3246918E-01	0.	-3.7007550E 03	0.	5.8408750E 03	0.
470.80	1.8916130E-02	0.	-1.1542814E 03	0.	1.3393531E 04	0.
486.39	6.5274239E-02	0.	-1.27427E 03	0.	1.3393531E 04	0.
486.39	6.5274239E-02	0.	-1.384E 03	0.	-5.5901250E 03	0.
500.00	4.3650627E-02	0.	9.57E 03	0.	-3.7547500E 04	0.
520.00	6.8283081E-04	0.	7.72E 03	0.	-3.7293750E 02	0.
		0.	77.	0.	-3.7293750E 02	0.
		0.		0.	1.3125000E 00	0.

Table 4.37 Fuselage Loading Symmetric Flight Maneuver

SYMMETRIC FLIGHT CONDITION F-17P

OUTPUT

F.S.	FX	FY	FZ	MX	MY	MZ
-70.00	0.	0.	-0.	0.	-0.	0.
0.	0.	0.	1.322000E 01	0.	3.8846195E 02	0.
20.00	0.	0.	-1.1062610E 02	0.	-2.6994034E 02	0.
35.20	0.	0.	-2.6239250E 02	0.	-3.0641456E 03	0.
47.00	0.	0.	-3.2696089E 02	0.	-6.5113051E 03	0.
59.00	0.	0.	-3.1767368E 02	0.	-1.0984881E 04	0.
71.00	0.	0.	-3.7173619E 02	0.	-1.4539245E 04	0.
82.60	0.	0.	-5.0843328E 02	0.	-1.9656696E 04	0.
91.00	0.	0.	-6.2387547E 02	0.	-2.4457887E 04	0.
110.00	0.	0.	-6.0318798E 02	0.	-3.7237879E 04	0.
110.00	0.	0.	-6.0318798E 02	0.	-3.7237879E 04	0.
122.50	0.	0.	-3.7416888E 02	0.	-4.3466976E 04	0.
136.50	0.	0.	-2.7066670E 02	0.	-4.5564964E 04	0.
136.50	0.	0.	2.7066670E 02	0.	-4.5564964E 04	0.
150.00	0.	0.	1.1751809E 03	0.	-3.3486235E 04	0.
165.20	0.	0.	1.5063458E 03	0.	-1.3540446E 04	0.
177.20	0.	0.	2.1726159E 03	0.	8.3648857E 03	0.
188.90	0.	0.	2.9170758E 03	0.	3.7999781E 04	0.
201.90	0.	0.	3.2775454E 03	0.	7.8644076E 04	0.
214.00	0.	0.	-6.7665471E 03	0.	1.2069921E 05	0.
214.00	0.	0.	-6.7665471E 03	0.	1.2069921E 05	0.
286.00	-1.5949479E 03	0.	7.5593609E 02	0.	-1.6814481E 05	0.
286.00	-1.5949479E 03	0.	7.5593609E 02	0.	-1.6814481E 05	0.
287.00	-4.2611673E 02	0.	1.3615718E 03	0.	-1.5877942E 05	0.
296.50	-4.2611673E 02	0.	1.9780171E 03	0.	-1.4728603E 05	0.
296.50	-4.2611673E 02	0.	3.1068372E 02	0.	-1.4728603E 05	0.
315.89	-4.2611673E 02	0.	9.9477886E 02	0.	-1.1869358E 05	0.
315.89	-4.2611673E 02	0.	9.9477886E 02	0.	-1.1869358E 05	0.
328.10	-4.2611673E 02	0.	1.1922974E 03	0.	-1.0728415E 05	0.
341.00	-4.2611673E 02	0.	1.3436174E 03	0.	-1.2720875E 05	0.
366.00	-4.2611673E 02	0.	1.6411143E 03	0.	-9.3410000E 04	0.
392.12	-4.2611673E 02	0.	1.8045163E 03	0.	-1.5437922E 04	0.
392.12	-4.2611673E 02	0.	1.4491232E 02	0.	-1.5054127E 04	0.
407.00	-7.0904073E 02	0.	2.3038318E 02	0.	-3.6731875E 03	0.
419.00	-7.0904073E 02	0.	3.1402954E 02	0.	4.7042500E 03	0.
429.23	-7.0904073E 02	0.	3.6890124E 02	0.	-1.2646875E 04	0.
429.23	-7.0904073E 02	0.	3.6890124E 02	0.	-1.2646875E 04	0.
446.55	-7.0904073E 02	0.	5.8945625E 02	0.	-1.2646875E 04	0.
455.22	-7.0904073E 02	0.	6.4634057E 02	0.	2.3491187E 04	0.
455.22	-7.0904073E 02	0.	6.6704614E 02	0.	8.8409843E 03	0.
470.80	-3.8146973E -05	0.	1.0275535E 02	0.	8.8409843E 03	0.
470.80	-3.8146973E -05	0.	1.4654700E 02	0.	1.0803687E 04	0.
486.39	-3.8146973E -05	0.	1.8614844E 02	0.	1.9211437E 04	0.
486.39	-3.8146973E -05	0.	-3.4406574E 01	0.	1.9211437E 04	0.
500.00	-3.8146973E -05	0.	-1.3273804E 01	0.	1.2921875E 02	0.
520.00	-3.8146973E -05	0.	-3.6621094E -04	0.	1.2921875E 02	0.
520.00	-3.8146973E -05	0.	-3.6621094E -04	0.	-2.1875000E -01	0.

Table 4.38 Fuselage Loading Symmetric Flight Maneuver

FUSELAGE SHEAR AND MOMENT PROGRAM - JOB NUMBER 1105 - 2/11/63

SYMMETRIC FLIGHT CONDITION F-24

OUTPUT

F.S.	FX	FY	FZ	MX	MY	MZ
-70.00	0.	0.	0.	0.	0.	0.
0.	6.0103105E-01	0.	-2.0295207E 01	0.	0.	0.
20.00	1.2946602E 00	0.	-2.4525911E 01	0.	-6.1996968E 02	0.
35.20	1.6039435E 00	0.	-3.1203845E 02	0.	-5.2940549E 02	0.
47.00	4.5290734E 00	0.	-8.2342598E 02	0.	-2.7475235E 03	0.
59.00	9.0268537E 00	0.	-1.6291428E 03	0.	-9.4231362E 03	0.
71.00	1.3234804E 01	0.	-2.8664635E 03	0.	-2.3266756E 04	0.
82.60	1.6970507E 01	0.	-4.7550924E 03	0.	-5.0296733E 04	0.
91.00	1.9936965E 01	0.	-6.3749040E 03	0.	-9.3872765E 04	0.
110.00	2.8107913E 01	0.	-7.7087433E 03	0.	-1.4057450E 05	0.
122.50	3.3365104E 01	0.	-7.7087433E 03	0.	-2.8298788E 05	0.
136.50	4.0984216E 01	0.	-5.5233389E 03	0.	-3.6852763E 05	0.
136.50	4.0984216E 01	0.	-4.7582736E 03	0.	-4.3357249E 05	0.
150.00	4.3681816E 01	0.	-4.7582736E 03	0.	-4.3357249E 05	0.
165.20	5.1918879E 01	0.	-5.7754223E 03	0.	-5.0777612E 05	0.
177.20	6.1025192E 01	0.	-6.3710160E 03	0.	-5.9983147E 05	0.
188.90	6.3919252E 01	0.	-6.9534950E 03	0.	-6.8058636E 05	0.
201.90	6.1518207E 01	0.	-7.3260847E 03	0.	-7.6467088E 05	0.
214.00	4.4161122E 01	0.	-6.9027061E 03	0.	-8.5913647E 05	0.
214.00	1.6673740E 02	0.	-2.0504680E 03	0.	-9.4358975E 05	0.
286.00	5.9496019E 01	0.	-2.2094713E 03	0.	-9.4503492E 05	0.
286.00	5.9496019E 01	0.	-2.2094713E 03	0.	-1.0783295E 06	0.
287.00	5.3478881E 01	0.	-2.2094713E 03	0.	-1.0783295E 06	0.
296.50	5.2250779E 01	0.	-3.2555971E 03	0.	-1.0801852E 06	0.
296.50	5.2250779E 01	0.	6.5593573E 03	0.	-1.1050075E 06	0.
315.89	5.7679942E 01	0.	6.1269907E 03	0.	-1.1050075E 06	0.
315.89	5.7679942E 01	0.	6.1269907E 03	0.	-9.7933108E 05	0.
328.10	6.0406759E 01	0.	6.0214377E 03	0.	-9.7933108E 05	0.
341.00	6.0159951E 01	0.	5.8656029E 03	0.	-9.0542377E 05	0.
366.00	5.4502237E 01	0.	5.2082175E 03	0.	-8.2883162E 05	0.
392.12	5.4576594E 01	0.	5.0385005E 03	0.	-6.9165609E 05	0.
392.12	5.4576594E 01	0.	5.0385005E 03	0.	-5.5858333E 05	0.
407.00	5.5866885E 01	0.	4.9796216E 03	0.	-5.5858333E 05	0.
419.00	5.800575E 01	0.	4.9243262E 03	0.	-4.8418256E 05	0.
429.23	5.9126194E 01	0.	4.8892605E 03	0.	-4.2474169E 05	0.
429.23	5.9126194E 01	0.	9.2071862E 03	0.	-3.7459525E 05	0.
446.55	5.8893338E 01	0.	9.1729046E 03	0.	-3.7459525E 05	0.
455.22	5.8840022E 01	0.	9.1609601E 03	0.	-2.1544581E 05	0.
455.22	6.6205025E-02	0.	4.3806814E 03	0.	-1.3596169E 05	0.
470.80	-9.4876289E-03	0.	4.3558249E 03	0.	-6.7938594E 04	0.
486.39	-3.2666683E-02	0.	4.3346865E 03	0.	-1.9006250E 02	0.
486.39	-3.2666683E-02	0.	1.6760742E 01	0.	-1.9006250E 02	0.
500.00	-2.1854877E-02	0.	6.1389160E 00	0.	-6.6968750E 01	0.
520.00	-3.7097931E-04	0.	2.6855469E-03	0.	2.8125000E-01	0.

Table 4.39 Fuselage Loading Symmetric Flight Maneuver

FUSELAGE SHEAR AND MOMENT PROGRAM - JOB NUMBER 1105 - 1/22/63

SYMMETRIC FLIGHT CONDITION F-3C

OUTPUT

F.S.	FX	FY	FZ	MX	MY	MZ
-70.00	-0.	0.	-0.	0.	-0.	0.
0.	-1.1534840E 00	0.	2.0452112E 01	0.	6.4708595E 02	0.
20.00	-2.4741586E 00	0.	-4.2619659E 01	0.	6.7755370E 02	0.
35.20	-3.0630460E 00	0.	-1.3849285E 02	0.	-6.4286250E 02	0.
47.00	-8.6339437E 00	0.	-1.3926997E 02	0.	-2.0475832E 03	0.
59.00	-1.7017183E 01	0.	-4.9351461E 01	0.	-3.6463474E 03	0.
71.00	-2.4916929E 01	0.	-2.8633548E 01	0.	-3.1854634E 03	0.
82.60	-3.1952073E 01	0.	-1.0238403E 02	0.	-3.7844553E 03	0.
91.00	-3.7656057E 01	0.	-1.7576226E 02	0.	-4.6311343E 03	0.
110.00	-5.2828441E 01	0.	-6.3236698E 01	0.	-7.6433557E 03	0.
122.50	-6.2453779E 01	0.	-2.0914440E 02	0.	-6.3462602E 03	0.
136.50	-7.5297022E 01	0.	8.5205398E 02	0.	7.7432510E 02	0.
150.00	-7.5297022E 01	0.	8.5205398E 02	0.	7.7432510E 02	0.
165.20	-9.2275319E 01	0.	1.6887325E 03	0.	2.1381771E 04	0.
177.20	-1.1000766E 02	0.	1.9859203E 03	0.	4.9456556E 04	0.
188.90	-1.1774907E 02	0.	3.0899252E 03	0.	7.7006456E 04	0.
201.90	-1.1567069E 02	0.	2.5195569E 03	0.	1.1069034E 05	0.
214.00	-7.8893701E 01	0.	3.367372E 03	0.	1.538653E 05	0.
228.00	-8.304034E 01	0.	-1.140050E 03	0.	1.9780129E 05	0.
287.00	-7.1259905E 01	0.	2.7689300E 02	0.	2.0047330E 05	0.
296.50	-6.7557621E 01	0.	4.6156081E 02	0.	2.1670985E 05	0.
296.50	-6.7557621E 01	0.	5.9149609E 02	0.	2.1754766E 05	0.
315.89	-7.5534306E 01	0.	-1.0978883E 03	0.	2.2171929E 05	0.
328.10	-8.1198570E 01	0.	-9.8493426E 02	0.	2.2171929E 05	0.
341.00	-8.7279346E 01	0.	-9.5325103E 02	0.	2.1217377E 05	0.
366.00	-1.0753310E 02	0.	-9.3748682E 02	0.	1.6697216E 05	0.
392.12	-1.1229355E 02	0.	-9.7251275E 02	0.	1.4132367E 05	0.
392.12	-1.1229355E 02	0.	-9.7621533E 02	0.	1.3494261E 05	0.
407.00	-1.1456633E 02	0.	-9.7621533E 02	0.	1.3494261E 05	0.
419.00	-1.1853222E 02	0.	-9.9709094E 02	0.	1.2527000E 05	0.
429.23	-1.2058663E 02	0.	-1.0073423E 03	0.	1.1646447E 05	0.
446.55	-1.1993196E 02	0.	-2.1527896E 03	0.	9.4420999E 04	0.
455.22	-1.1974000E 02	0.	-2.1584179E 03	0.	7.1747844E 04	0.
455.22	-5.5195904E-01	0.	-2.1584179E 03	0.	4.1526703E 04	0.
470.80	-2.4333954E-01	0.	-1.0874836E 03	0.	2.4455734E 04	0.
486.39	-5.5094719E-02	0.	-1.1020435E 03	0.	1.0462547E 04	0.
486.39	-5.5094719E-02	0.	-1.1176559E 03	0.	1.0462547E 04	0.
500.00	-1.8177032E-03	0.	6.2857666E 00	0.	1.0482547E 04	0.
520.00	1.2054443E-03	0.	-1.7089844E-03	0.	-6.6390625E 01	0.
					-1.4062550E-01	0.

Table 4.40 Fuselage Loading Symmetric Flight Maneuver

FUSELAGE SHEAR AND MOMENT PROGRAM - JCF NUMBER 1105 - 1/22/63

SYMMETRIC FLIGHT CONDITION F-32

OUTPUT

F.S.	FX	FY	FZ	MX	MY	MZ
-70.00	-0.	0.	-0.	0.	-5.5724646E 02	0.
0.	-1.2020621E 00	0.	2.0760414E 01	0.	7.0573072E 02	0.
20.00	-2.5852204E 00	0.	-4.1169100E 01	0.	-5.8503921E 02	0.
35.00	-3.2078871E 00	0.	-1.3614734E 02	0.	-1.9426132E 03	0.
47.00	-9.0581467E 00	0.	-1.3458633E 02	0.	-3.4647099E 03	0.
59.00	-1.8053707E 01	0.	-4.0191053E 01	0.	-2.8509214E 03	0.
71.00	-2.6469607E 01	0.	-1.5591593E 01	0.	-3.2752080E 03	0.
82.00	-3.3541014E 01	0.	-8.6225994E 01	0.	-4.1725419E 03	0.
91.00	-3.9873929E 01	0.	-1.5746817E 02	0.	-6.5551262E 03	0.
110.00	-5.6215827E 01	0.	-3.6476227E 01	0.	-4.8766826E 03	0.
122.00	-6.6730207E 01	0.	2.4218123E 02	0.	2.7991275E 03	0.
136.00	-8.1968431E 01	0.	9.0108055E 02	0.	2.7991275E 03	0.
136.50	-8.1968431E 01	0.	9.0108055E 02	0.	2.7991275E 03	0.
150.00	-8.7363632E 01	0.	1.7610899E 03	0.	3.4281165E 04	0.
155.00	-1.0283776E 02	0.	2.0555539E 03	0.	5.3535793E 04	0.
177.00	-1.2250388E 02	0.	2.4973003E 03	0.	8.1409854E 04	0.
188.00	-1.2783850E 02	0.	2.9570441E 03	0.	1.1414440E 05	0.
201.00	-1.2303641E 02	0.	3.1298349E 03	0.	1.5448927E 05	0.
214.00	-8.8322244E 01	0.	3.4020243E 03	0.	1.9504369E 05	0.
214.50	-3.3347481E 02	0.	-1.9733564E 03	0.	1.9793404E 05	0.
286.00	-1.189204E 02	0.	1.3175738E 02	0.	2.0002597E 05	0.
286.00	-1.189204E 02	0.	1.3175738E 02	0.	2.0002597E 05	0.
287.00	-1.0695776E 02	0.	3.4332416E 02	0.	2.0069858E 05	0.
296.00	-1.0450156E 02	0.	4.9599333E 02	0.	2.0373058E 05	0.
296.50	-1.0450156E 02	0.	-1.1031710E 03	0.	2.0373058E 05	0.
315.00	-1.1535888E 02	0.	-9.7146941E 02	0.	1.9409291E 05	0.
328.00	-1.2061352E 02	0.	-9.7146941E 02	0.	1.8163077E 05	0.
341.00	-1.2031990E 02	0.	-9.3334466E 02	0.	1.4984093E 05	0.
366.00	-1.0900447E 02	0.	-5.9174474E 02	0.	1.2643150E 05	0.
392.12	-1.0915319E 02	0.	-8.5968175E 02	0.	1.2217696E 05	0.
392.12	-1.0915319E 02	0.	-8.5968175E 02	0.	1.2217696E 05	0.
407.00	-1.173377E 02	0.	-8.9552673E 02	0.	1.1376156E 05	0.
419.00	-1.1600115E 02	0.	-9.0669231E 02	0.	1.0600027E 05	0.
429.00	-1.1825239E 02	0.	-9.1569402E 02	0.	9.5012765E 04	0.
429.23	-1.1825239E 02	0.	-9.1569402E 02	0.	9.5012765E 04	0.
446.55	-1.1779868E 02	0.	-1.9370746E 03	0.	5.5914578E 04	0.
455.22	-1.1769004E 02	0.	-1.9422393E 03	0.	3.7654500E 04	0.
455.22	-1.3241005E -01	0.	-9.6735925E 02	0.	3.7654500E 04	0.
470.00	1.8975258E -02	0.	-9.5092041E 02	0.	2.2494015E 04	0.
486.39	6.5333666E -02	0.	-9.3553208E 02	0.	1.0361469E 04	0.
486.39	6.5333666E -02	0.	1.4350006E 01	0.	1.0361469E 04	0.
500.00	4.3709755E -02	0.	5.9923096E 00	0.	-6.3328125E 01	0.
520.00	7.4195862E -04	0.	-2.0751953E -03	0.	-2.3437500E -01	0.

Table 4.41 Fuselage Loading Symmetric Flight Maneuver

FUSELAGE SHEAR AND MOMENT PROGRAM - JOB NO. 111103 - 10 APRIL 68

SYMMETRIC FLIGHT - CONTINUOUS

OUTPUT

FX	FY	FZ	UX	UY	UZ
-7000	00000000	00000000	00000000	00000000	00000000
0000	00000000	00000000	00000000	00000000	00000000
20000	00000000	00000000	00000000	00000000	00000000
35000	00000000	00000000	00000000	00000000	00000000
47000	00000000	00000000	00000000	00000000	00000000
55000	00000000	00000000	00000000	00000000	00000000
71000	00000000	00000000	00000000	00000000	00000000
82000	00000000	00000000	00000000	00000000	00000000
91000	00000000	00000000	00000000	00000000	00000000
110000	00000000	00000000	00000000	00000000	00000000
115000	00000000	00000000	00000000	00000000	00000000
125000	00000000	00000000	00000000	00000000	00000000
136000	00000000	00000000	00000000	00000000	00000000
136000	00000000	00000000	00000000	00000000	00000000
150000	00000000	00000000	00000000	00000000	00000000
160000	00000000	00000000	00000000	00000000	00000000
177000	00000000	00000000	00000000	00000000	00000000
186000	00000000	00000000	00000000	00000000	00000000
201000	00000000	00000000	00000000	00000000	00000000
214000	00000000	00000000	00000000	00000000	00000000
226000	00000000	00000000	00000000	00000000	00000000
236000	00000000	00000000	00000000	00000000	00000000
256000	00000000	00000000	00000000	00000000	00000000
266000	00000000	00000000	00000000	00000000	00000000
286000	00000000	00000000	00000000	00000000	00000000
297000	00000000	00000000	00000000	00000000	00000000
306000	00000000	00000000	00000000	00000000	00000000
315000	00000000	00000000	00000000	00000000	00000000
315000	00000000	00000000	00000000	00000000	00000000
320000	00000000	00000000	00000000	00000000	00000000
341000	00000000	00000000	00000000	00000000	00000000
366000	00000000	00000000	00000000	00000000	00000000
372000	00000000	00000000	00000000	00000000	00000000
392000	00000000	00000000	00000000	00000000	00000000
407000	00000000	00000000	00000000	00000000	00000000
419000	00000000	00000000	00000000	00000000	00000000
429000	00000000	00000000	00000000	00000000	00000000
439000	00000000	00000000	00000000	00000000	00000000
450000	00000000	00000000	00000000	00000000	00000000
470000	00000000	00000000	00000000	00000000	00000000
486000	00000000	00000000	00000000	00000000	00000000
486000	00000000	00000000	00000000	00000000	00000000
500000	00000000	00000000	00000000	00000000	00000000
520000	00000000	00000000	00000000	00000000	00000000

Table 4.42 Fuselage Loading Symmetric Flight Manuever

SYMMETRIC FLIGHT CONDITION F-34

OUTPUT

F.S.	FX	FY	FZ	PX	MY	MZ
70.00	-0.	0.	0.	0.	0.	0.
0.	-1.1534640E 02	0.	6.2211267E-01	0.	6.4393082E 01	0.
20.00	-2.4741586E 00	0.	6.3761162E 01	0.	6.4689275E 02	0.
30.00	-3.6630460E 00	0.	1.0210677E 02	0.	1.9470179E 03	0.
47.00	-6.6339437E 00	0.	1.0163397E 02	0.	3.3589212E 03	0.
50.00	-1.7517163E 01	0.	5.8918213E 01	0.	4.7839834E 03	0.
71.00	-2.4526929E 01	0.	-1.7692381E 01	0.	5.1673482E 03	0.
82.60	-3.1392073E 01	0.	-1.5157348E 02	0.	4.4664935E 03	0.
91.00	-3.7656057E 01	0.	-2.6510091E 02	0.	2.9502833E 03	0.
110.00	-5.2828441E 01	0.	-4.2670605E 02	0.	-3.4768940E 03	0.
122.50	-6.283379E 01	0.	-3.3766748E 02	0.	-3.64768340E 03	0.
136.50	-7.527022E 01	0.	-4.9350876E 02	0.	-7.505572E 03	0.
150.00	-7.712516E 01	0.	-4.9350876E 02	0.	-1.1611721E 04	0.
163.20	-9.2475319E 01	0.	-9.7608570E 02	0.	-2.1611721E 04	0.
177.20	-1.1360765E 02	0.	-1.190801E 03	0.	-3.722172E 04	0.
190.50	-1.174807E 02	0.	-1.5287561E 03	0.	-5.323335E 04	0.
214.00	-1.167609E 02	0.	-2.1517147E 03	0.	-7.4371482E 04	0.
226.00	-1.3042034E 01	0.	-2.3742412E 03	0.	-1.0355368E 05	0.
237.00	-1.359505E 01	0.	-2.8025895E 03	0.	-1.319854E 05	0.
246.50	-1.437621E 01	0.	-2.373240E 03	0.	-1.55130E 05	0.
256.50	-1.537521E 01	0.	-4.4162438E 02	0.	-7.655737E 04	0.
266.50	-1.653310E 01	0.	-1.173979E 03	0.	-7.5256675E 04	0.
276.50	-1.7857621E 01	0.	-2.3587745E 03	0.	-5.479039E 04	0.
286.50	-1.934306E 01	0.	1.3923077E 03	0.	-8.479039E 04	0.
296.50	-2.098570E 01	0.	1.3923077E 03	0.	-5.771939E 04	0.
306.50	-2.278545E 01	0.	1.1293395E 03	0.	-4.074055E 04	0.
316.50	-2.473531E 01	0.	9.1975548E 02	0.	-1.194946E 03	0.
326.50	-2.683535E 01	0.	4.194233E 02	0.	1.801397E 03	0.
336.50	-2.907555E 01	0.	1.7621252E 02	0.	2.505937E 03	0.
346.50	-3.145632E 01	0.	4.3401245E 01	0.	2.450937E 03	0.
356.50	-3.397822E 01	0.	-9.2575604E 01	0.	-2.0711512E 03	0.
366.50	-3.663663E 01	0.	-1.6236677E 02	0.	-7.173732E 03	0.
376.50	-3.942663E 01	0.	-3.546576E 02	0.	7.613036E 03	0.
386.50	-4.234319E 01	0.	-5.2427956E 02	0.	-1.6024428E 04	0.
396.50	-4.53904E 01	0.	-4.346552E 02	0.	-7.79025E 03	0.
406.50	-4.85754E 01	0.	-7.4225708E 01	0.	-7.79025E 03	0.
416.50	-5.189719E 01	0.	-1.4756924E 02	0.	-8.355462E 03	0.
426.50	-5.535719E 01	0.	6.4192555E 01	0.	-1.4265031E 04	0.
436.50	-5.895733E 01	0.	2.511333E 01	0.	-2.4327632E 04	0.
446.50	-6.269443E 01	0.	2.4474362E 04	0.	5.612530E 04	0.

Table 4.43 Fuselage Loading Symmetric Flight Manuever

FUSELAGE SHEAR AND MOMENT PROGRAM - JOB NUMBER 1105 - 30 APRIL 63

SYMMETRIC FLIGHT CONDITION --30

OUTPUT

FX	FY	FZ	MX	MY
7000	0	0	0	0
2000	0	9.3041455E-01	0	7.4553540E 01
3520	0	6.2514706E 01	0	6.5116904E 02
4700	0	9.8901859E 01	0	1.9249475E 03
5900	0	1.9057806E 02	0	5.0223471E 03
7100	0	6.1573911E 01	0	4.7502576E 03
8250	0	-1.0751169E 01	0	5.2247735E 03
9100	0	-1.3926795E 02	0	4.6215245E 03
11000	0	-2.4485465E 02	0	5.1633291E 03
12250	0	-4.0234277E 02	0	-2.7544750E 03
13650	0	-4.0234277E 02	0	-2.7544750E 03
15000	0	-3.1423139E 03	0	-6.0029652E 03
16500	0	-4.4516200E 02	0	-1.0441177E 04
18000	0	-4.6162001E 02	0	1.0441177E 04
19800	0	-9.2496235E 02	0	1.2637592E 04
21700	0	-1.1107566E 03	0	3.4237729E 04
23700	0	-1.4463265E 03	0	4.9026249E 04
25800	0	-1.8159495E 03	0	6.7086479E 04
28000	0	-1.9018370E 03	0	8.0940571E 04
30300	0	-2.1691665E 03	0	1.0228406E 05
32800	0	2.8350912E 03	0	-1.1206433E 05
35400	0	4.8037066E 03	0	-2.0226650E 05
38100	0	4.8037066E 03	0	-2.0226650E 05
40900	0	-7.1257535E 02	0	1.2320410E 05
43800	0	-1.5795009E 03	0	2.3230662E 05
46800	0	2.6598094E 03	0	-2.3510604E 05
49900	0	1.7106611E 03	0	5.9220780E 05
53100	0	1.7106611E 03	0	5.9220780E 05
56400	0	1.4425763E 02	0	3.0731167E 05
59800	0	1.1336786E 03	0	7.5232103E 05
63300	0	-1.8211852E 01	0	9.1233397E 05
66900	0	-3.6575782E 02	0	6.2356531E 05
70600	0	-3.6575782E 02	0	6.2356531E 05
74400	0	-4.9550593E 02	0	5.0223275E 05
78300	0	-6.3262317E 02	0	4.0144597E 05
82300	0	-7.2177942E 02	0	4.7758112E 05
86400	0	-1.1983126E 01	0	4.7758112E 05
90600	0	-1.4763990E 03	0	5.2430322E 05
95000	0	-4.4796558E 02	0	6.5631213E 05
99500	0	-5.2557549E 02	0	6.5631213E 05
104100	0	-5.9805050E 02	0	-1.0712612E 05
108800	0	6.3478348E 01	0	-1.0712612E 05
113600	0	2.6844360E 01	0	-1.2553094E 05
118500	0	2.4414062E -04	0	-2.4509255E 05
123500	0	2.4414062E -04	0	6.2550000E 05

Table 4.44 Fuselage Loading Symmetric Flight Manoeuvr

FUSELAGE SHEAR AND MOMENT PROGRAM - JOB NUMBER 1105 - 30 APRIL 63

SYMMETRIC FLIGHT CONDITION 6-37

F.S.	OUTPUT					
	FX	FY	FZ	MX	MY	MZ
-70.00	0.	0.	0.	0.	0.	0.
0.	0.	0.	-1.323000E 01	0.	-3.6846195E 02	0.
20.00	0.	0.	-3.689990E 01	0.	-7.9155586E 02	0.
35.00	0.	0.	-1.2951501E 02	0.	-1.9713937E 03	0.
47.00	0.	0.	-3.2242694E 01	0.	-6.6092151E 03	0.
59.00	0.	0.	-6.3143700E 02	0.	-9.7897459E 03	0.
71.00	0.	0.	-1.0664959E 03	0.	-2.0514659E 04	0.
82.60	0.	0.	-1.6558241E 03	0.	-3.6235000E 04	0.
91.00	0.	0.	-2.1640966E 03	0.	-5.2482876E 04	0.
110.00	0.	0.	-2.8453633E 03	0.	-1.0164422E 05	0.
122.50	0.	0.	-2.8453633E 03	0.	-1.0164422E 05	0.
136.50	0.	0.	-2.7403650E 03	0.	-1.3614461E 05	0.
136.50	0.	0.	-2.7403650E 03	0.	-1.7167619E 05	0.
150.00	0.	0.	-3.5193072E 03	0.	-1.7167619E 05	0.
165.00	0.	0.	-3.8452148E 03	0.	-2.3158790E 05	0.
177.20	0.	0.	-4.4461751E 03	0.	-2.7144397E 05	0.
188.90	0.	0.	-5.0446209E 03	0.	-3.2108855E 05	0.
201.90	0.	0.	-5.3055906E 03	0.	-3.7679518E 05	0.
214.00	0.	0.	-5.6732755E 03	0.	-4.4483554E 05	0.
214.00	0.	0.	-1.0850185E 03	0.	-1.0150952E 05	0.
285.00	0.	0.	-5.6732755E 03	0.	-1.0350952E 05	0.
286.00	0.	0.	-3.5642228E 03	0.	-6.9319355E 05	0.
287.00	0.	0.	-4.1907671E 03	0.	-6.9319355E 05	0.
296.50	0.	0.	-4.1907671E 03	0.	-6.9319355E 05	0.
296.50	0.	0.	5.1853255E 03	0.	-7.3524099E 05	0.
315.89	0.	0.	4.3643144E 03	0.	-7.3524099E 05	0.
315.89	0.	0.	4.3643144E 03	0.	-6.9074059E 05	0.
328.10	0.	0.	4.1749576E 03	0.	-6.9074059E 05	0.
341.00	0.	0.	4.0309252E 03	0.	-3.9739393E 05	0.
366.00	0.	0.	3.7095627E 03	0.	-5.9240716E 05	0.
392.12	0.	0.	3.5530941E 03	0.	-4.2597039E 05	0.
392.12	0.	0.	3.5530941E 03	0.	-3.4999997E 05	0.
407.00	0.	0.	3.4766579E 03	0.	-3.4999997E 05	0.
419.00	0.	0.	3.4083556E 03	0.	-3.0351329E 05	0.
429.23	0.	0.	3.3517486E 03	0.	-2.6971181E 05	0.
429.23	0.	0.	5.5346221E 03	0.	-2.1775772E 05	0.
446.55	0.	0.	5.4883102E 03	0.	-2.1775772E 05	0.
455.22	0.	0.	5.4715554E 03	0.	-1.35572354E 05	0.
455.22	0.	0.	2.2836021E 03	0.	-7.7665000E 05	0.
479.80	0.	0.	2.2443235E 03	0.	-7.7665000E 05	0.
486.39	0.	0.	2.2100788E 03	0.	-4.2418587E 05	0.
486.39	0.	0.	2.7206329E 03	0.	-1.0994562E 05	0.
500.00	0.	0.	1.0207520E 03	0.	-1.0994562E 05	0.
520.00	0.	0.	1.9310547E 03	0.	-1.0958750E 05	0.
520.00	0.	0.	1.9310547E 03	0.	5.3125000E -01	0.

Table 4.45 Fuselage Loading Symmetric Flight Maneuver

FUSELAGE SHEAR AND MOMENT PROGRAM - JOE NUMBER 1105 - 30 APRIL 63

SYMMETRIC FLIGHT CONDITION F-42

OUTPUT

F.S.	FX	FY	FZ	FX	FY	FZ	FX	FY	FZ	FX	FY	FZ
-70.00	3.7674200E-01	0.0	0.0	0.0	0.0	0.0	0.0	0.0	0.0	0.0	0.0	0.0
0.0	1.2370793E-00	0.0	0.0	0.0	0.0	0.0	0.0	0.0	0.0	0.0	0.0	0.0
20.00	1.5515230E-00	0.0	0.0	0.0	0.0	0.0	0.0	0.0	0.0	0.0	0.0	0.0
55.00	4.3167161E-00	0.0	0.0	0.0	0.0	0.0	0.0	0.0	0.0	0.0	0.0	0.0
47.00	8.5059145E-00	0.0	0.0	0.0	0.0	0.0	0.0	0.0	0.0	0.0	0.0	0.0
59.00	1.2458465E-01	0.0	0.0	0.0	0.0	0.0	0.0	0.0	0.0	0.0	0.0	0.0
71.00	1.5996337E-01	0.0	0.0	0.0	0.0	0.0	0.0	0.0	0.0	0.0	0.0	0.0
82.00	1.5520255E-01	0.0	0.0	0.0	0.0	0.0	0.0	0.0	0.0	0.0	0.0	0.0
91.00	2.6414220E-01	0.0	0.0	0.0	0.0	0.0	0.0	0.0	0.0	0.0	0.0	0.0
110.00	2.6414220E-01	0.0	0.0	0.0	0.0	0.0	0.0	0.0	0.0	0.0	0.0	0.0
110.00	3.1233890E-01	0.0	0.0	0.0	0.0	0.0	0.0	0.0	0.0	0.0	0.0	0.0
122.50	3.7643511E-01	0.0	0.0	0.0	0.0	0.0	0.0	0.0	0.0	0.0	0.0	0.0
156.50	3.7643511E-01	0.0	0.0	0.0	0.0	0.0	0.0	0.0	0.0	0.0	0.0	0.0
136.50	3.6553559E-01	0.0	0.0	0.0	0.0	0.0	0.0	0.0	0.0	0.0	0.0	0.0
150.00	4.6137660E-01	0.0	0.0	0.0	0.0	0.0	0.0	0.0	0.0	0.0	0.0	0.0
165.00	5.5403825E-01	0.0	0.0	0.0	0.0	0.0	0.0	0.0	0.0	0.0	0.0	0.0
177.00	5.8873535E-01	0.0	0.0	0.0	0.0	0.0	0.0	0.0	0.0	0.0	0.0	0.0
108.00	3.7853345E-01	0.0	0.0	0.0	0.0	0.0	0.0	0.0	0.0	0.0	0.0	0.0
201.00	3.9446851E-01	0.0	0.0	0.0	0.0	0.0	0.0	0.0	0.0	0.0	0.0	0.0
214.00	1.5273367E-02	0.0	0.0	0.0	0.0	0.0	0.0	0.0	0.0	0.0	0.0	0.0
256.00	4.1500317E-01	0.0	0.0	0.0	0.0	0.0	0.0	0.0	0.0	0.0	0.0	0.0
287.00	3.5628952E-01	0.0	0.0	0.0	0.0	0.0	0.0	0.0	0.0	0.0	0.0	0.0
296.50	3.3778111E-01	0.0	0.0	0.0	0.0	0.0	0.0	0.0	0.0	0.0	0.0	0.0
296.50	3.3778111E-01	0.0	0.0	0.0	0.0	0.0	0.0	0.0	0.0	0.0	0.0	0.0
315.00	3.7767155E-01	0.0	0.0	0.0	0.0	0.0	0.0	0.0	0.0	0.0	0.0	0.0
315.00	3.7767155E-01	0.0	0.0	0.0	0.0	0.0	0.0	0.0	0.0	0.0	0.0	0.0
328.10	4.0395265E-01	0.0	0.0	0.0	0.0	0.0	0.0	0.0	0.0	0.0	0.0	0.0
341.00	4.3553673E-01	0.0	0.0	0.0	0.0	0.0	0.0	0.0	0.0	0.0	0.0	0.0
366.00	3.3765745E-01	0.0	0.0	0.0	0.0	0.0	0.0	0.0	0.0	0.0	0.0	0.0
352.12	3.6146774E-01	0.0	0.0	0.0	0.0	0.0	0.0	0.0	0.0	0.0	0.0	0.0
392.12	3.0146774E-01	0.0	0.0	0.0	0.0	0.0	0.0	0.0	0.0	0.0	0.0	0.0
407.00	3.7203155E-01	0.0	0.0	0.0	0.0	0.0	0.0	0.0	0.0	0.0	0.0	0.0
419.00	3.9266137E-01	0.0	0.0	0.0	0.0	0.0	0.0	0.0	0.0	0.0	0.0	0.0
429.23	6.0293315E-01	0.0	0.0	0.0	0.0	0.0	0.0	0.0	0.0	0.0	0.0	0.0
429.23	6.0293315E-01	0.0	0.0	0.0	0.0	0.0	0.0	0.0	0.0	0.0	0.0	0.0
446.55	3.3565800E-01	0.0	0.0	0.0	0.0	0.0	0.0	0.0	0.0	0.0	0.0	0.0
455.22	3.9270002E-01	0.0	0.0	0.0	0.0	0.0	0.0	0.0	0.0	0.0	0.0	0.0
455.22	3.9270002E-01	0.0	0.0	0.0	0.0	0.0	0.0	0.0	0.0	0.0	0.0	0.0
470.80	1.2166977E-01	0.0	0.0	0.0	0.0	0.0	0.0	0.0	0.0	0.0	0.0	0.0
486.39	2.7547359E-02	0.0	0.0	0.0	0.0	0.0	0.0	0.0	0.0	0.0	0.0	0.0
466.35	2.7547359E-02	0.0	0.0	0.0	0.0	0.0	0.0	0.0	0.0	0.0	0.0	0.0
500.00	3.0883162E-04	0.0	0.0	0.0	0.0	0.0	0.0	0.0	0.0	0.0	0.0	0.0
520.00	-6.0272217E-04	0.0	0.0	0.0	0.0	0.0	0.0	0.0	0.0	0.0	0.0	0.0

Table 4.46 Fuselage Loading Symmetric Flight Manuever

FUSELAGE SHEAR AND MOMENT PROGRAM - JOB NUMBER 1105 - 30 APRIL 63

SYMMETRIC FLIGHT CONDITION F-44

F.S.	FX	FY	FZ	MX	MY	MZ
-70.00	6.5103108E-01	0.0	1.563207E 01	0.0	0.0	0.0
0.0	1.2346602E 00	0.0	0.9286741E 01	0.0	-4.2573872E 03	0.0
20.00	1.6325435E 00	0.0	2.027270E 02	0.0	-1.2731270E 03	0.0
35.00	4.340733E 00	0.0	4.0997185E 02	0.0	-3.5422537E 03	0.0
47.00	5.0266537E 00	0.0	5.091199E 02	0.0	-7.7999405E 03	0.0
59.00	1.3234809E 01	0.0	1.221148E 03	0.0	-1.4273279E 04	0.0
71.00	1.5730507E 01	0.0	1.3983464E 03	0.0	-2.7797255E 04	0.0
82.00	1.9936969E 01	0.0	1.671944E 03	0.0	-4.609521CE 04	0.0
91.00	2.5107913E 01	0.0	2.071944E 03	0.0	-6.455706E 04	0.0
110.00	3.3197113E 01	0.0	3.0761944E 03	0.0	-1.1798305E 05	0.0
122.00	4.333108E 01	0.0	4.221775E 03	0.0	-1.5536097E 05	0.0
130.00	5.574216E 01	0.0	5.633549E 03	0.0	-1.7423266E 05	0.0
150.00	7.031818E 01	0.0	7.3737516E 03	0.0	-1.7423266E 05	0.0
165.00	8.4316675E 01	0.0	8.5701494E 03	0.0	-2.3810542E 05	0.0
177.00	9.613193E 01	0.0	9.573150E 03	0.0	-2.7107557E 05	0.0
186.00	1.0319253E 01	0.0	1.01578795E 03	0.0	-3.3520767E 05	0.0
201.00	1.118203E 01	0.0	1.0944312E 03	0.0	-3.933364E 05	0.0
214.00	1.2161121E 01	0.0	1.197396E 03	0.0	-4.3514560E 05	0.0
214.00	1.2161121E 02	0.0	1.197396E 03	0.0	-1.389537E 05	0.0
286.00	1.5456013E 01	0.0	1.4268981E 03	0.0	-1.389537E 05	0.0
286.00	1.5456013E 01	0.0	1.4268981E 03	0.0	-7.5264358E 05	0.0
267.00	1.470851E 01	0.0	1.352177E 03	0.0	-7.5264358E 05	0.0
256.50	1.350775E 01	0.0	1.242387E 03	0.0	-7.5264358E 05	0.0
266.50	1.250775E 01	0.0	1.142387E 03	0.0	-7.5264358E 05	0.0
315.89	1.797594E 01	0.0	1.685101E 03	0.0	-8.0775129E 05	0.0
315.89	1.797594E 01	0.0	1.685101E 03	0.0	-8.0775129E 05	0.0
328.10	1.606750E 01	0.0	1.5222342E 03	0.0	-7.2131596E 05	0.0
341.00	1.59951E 01	0.0	1.505559E 03	0.0	-7.2131596E 05	0.0
366.00	1.402237E 01	0.0	1.308344E 03	0.0	-6.6810371E 05	0.0
392.12	1.457659E 01	0.0	1.3621570E 03	0.0	-6.0795617E 05	0.0
392.12	1.457659E 01	0.0	1.3621570E 03	0.0	-3.0463255E 05	0.0
437.00	1.536895E 01	0.0	1.473286E 03	0.0	-3.0463255E 05	0.0
413.00	1.500575E 01	0.0	1.433769E 03	0.0	-4.0492564E 05	0.0
429.23	1.32619E 01	0.0	1.255733E 03	0.0	-3.462211E 05	0.0
429.23	1.32619E 01	0.0	1.255733E 03	0.0	-3.000230E 05	0.0
446.55	1.5126194E 01	0.0	1.474547E 03	0.0	-3.5660905E 05	0.0
446.55	1.5126194E 01	0.0	1.474547E 03	0.0	-1.566035E 05	0.0
455.22	1.584002E 01	0.0	1.5612275E 03	0.0	-1.4513584E 05	0.0
455.22	1.584002E 01	0.0	1.5612275E 03	0.0	-8.4795250E 04	0.0
455.22	1.584002E 01	0.0	1.5612275E 03	0.0	-8.4795250E 04	0.0
470.60	1.485283E 02	0.0	2.553208E 03	0.0	-6.795530E 04	0.0
486.39	1.206688E 02	0.0	1.653095E 03	0.0	-3.527344E 04	0.0
486.39	1.206688E 02	0.0	1.653095E 03	0.0	-2.5135437E 03	0.0
500.00	1.183497E 02	0.0	1.5946458E 03	0.0	-1.5135437E 03	0.0
520.00	1.170793E 02	0.0	1.579353E 03	0.0	1.543200E 01	0.0
520.00	1.170793E 02	0.0	1.579353E 03	0.0	1.562500E 01	0.0

Table 4.47 Fuselage Loading Symmetric Flight Maneuver

FUSELAGE VERTICAL BENDING MOMENT $\sim M_1$, LBS. $\times 10^{-5}$
 FUSELAGE VERTICAL SHEAR $\sim F_2$, LBS. $\times 10^{-3}$

NOTE: CORRESPONDING MOMENT AND SHEAR CURVES ARE JOINED BY ARROWS
 ALTITUDE = SEA LEVEL

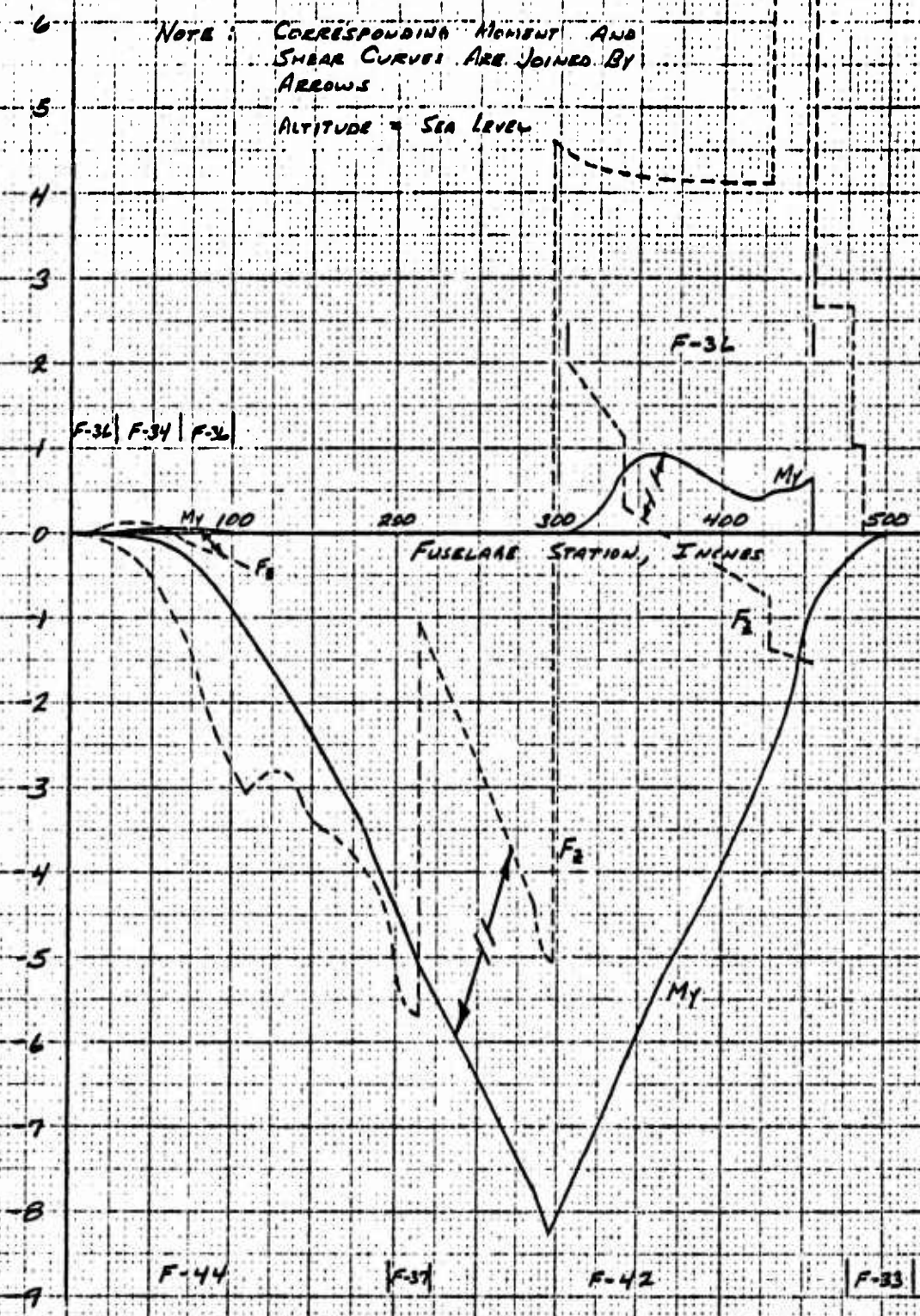

Figure 4.25 Fuselage Loading Envelope Curves Symmetrical Flaps-Down Flight Conditions

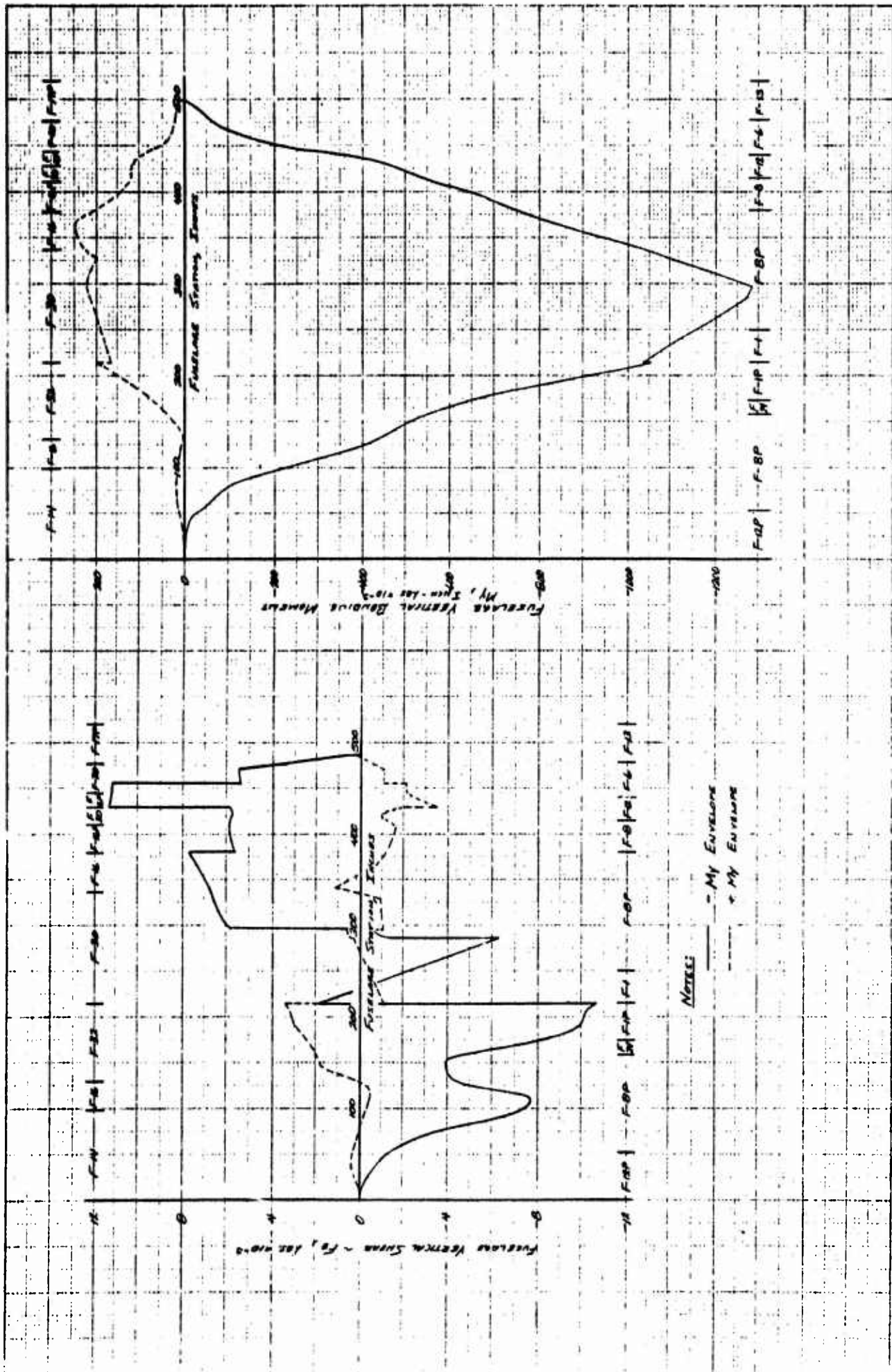

Figure 4.26 Fuselage Loading Envelope Curves Symmetrical Flaps-up Flight Conditions

In Figure 4.31 the resultant bending moment (M_R) curve for all lateral gust and rudder maneuver conditions is presented. Again, the M_Z and M_Y curves shown on the figure give the values of these moments which result in the peak value of M_R .

The curves of Figures 4.32 through 4.34 were constructed to provide values of the fuselage vertical loading for the lateral gust and rudder maneuvers. It was seen on Figure 4.17 that values of the lateral loading parameters peak at Mach numbers of .383, .638, and .756. The vertical one-g fuselage loading of Figures 4.32 through 4.34 are for these three Mach numbers.

Three lateral-gust conditions and four rudder-maneuver conditions produced the highest fuselage loads for these types of maneuvers.

Tables 4.48 through 4.54 show calculated values of fuselage distributed fuselage loading for these seven conditions.

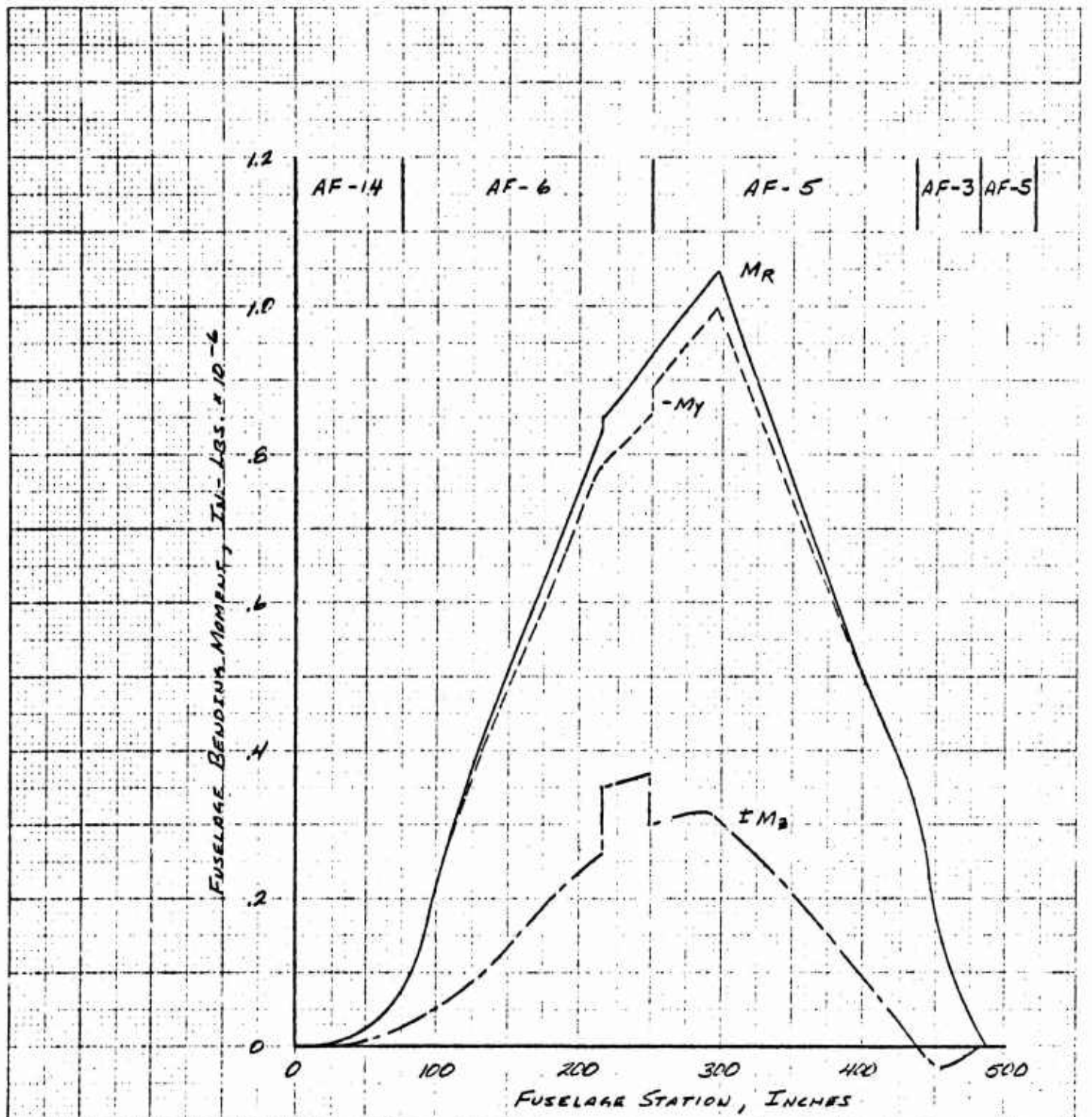

Figure 4.27 Fuselage Bending Moment Envelope Curves Dynamic Overswing Rudder Maneuvers.

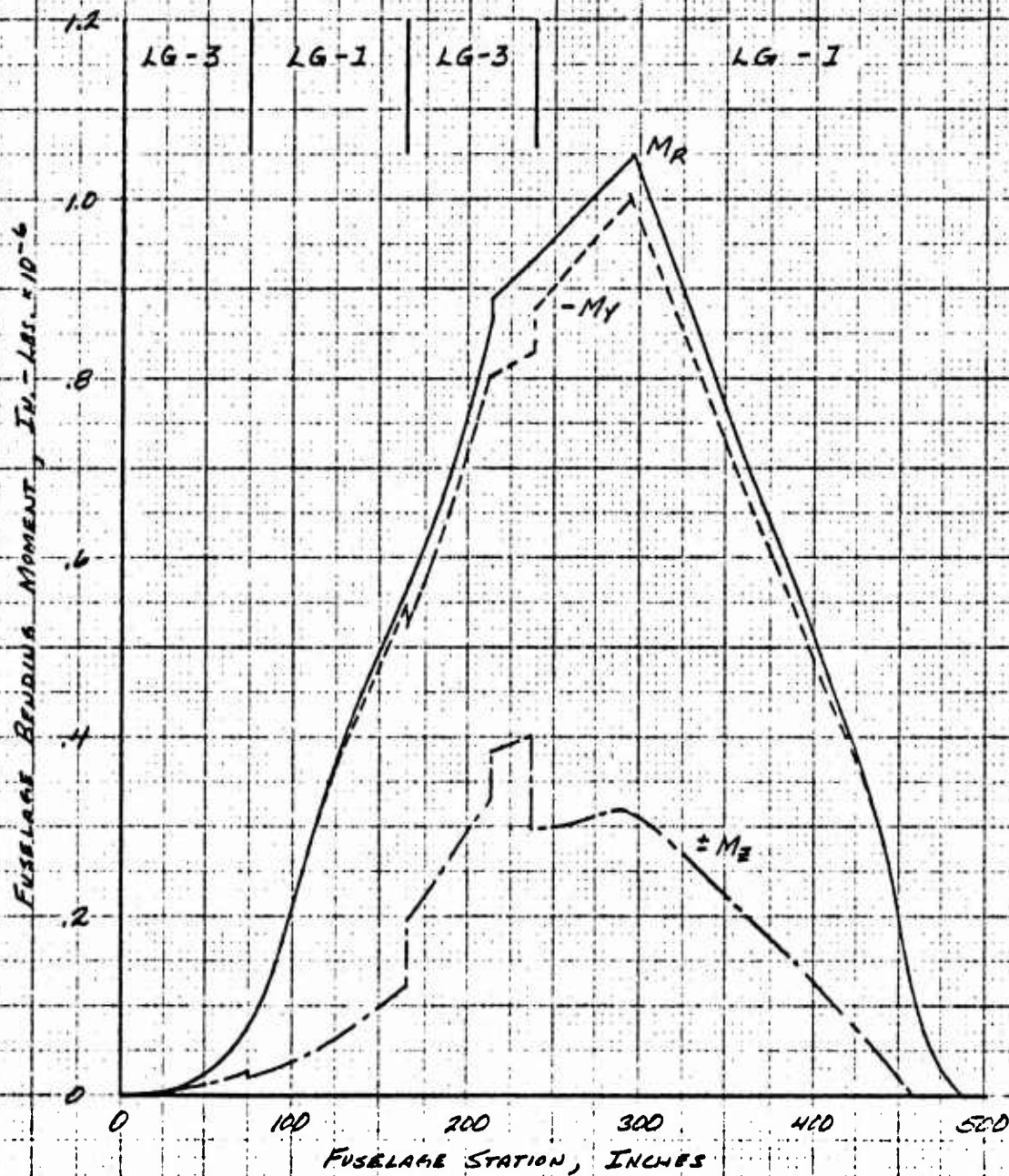

Figure 4.28 Fuselage Bending Moment Envelope Curves Lateral Gust Conditions

FUSELAGE TORSIONAL MOMENT $\times 10^{-4}$ INCH

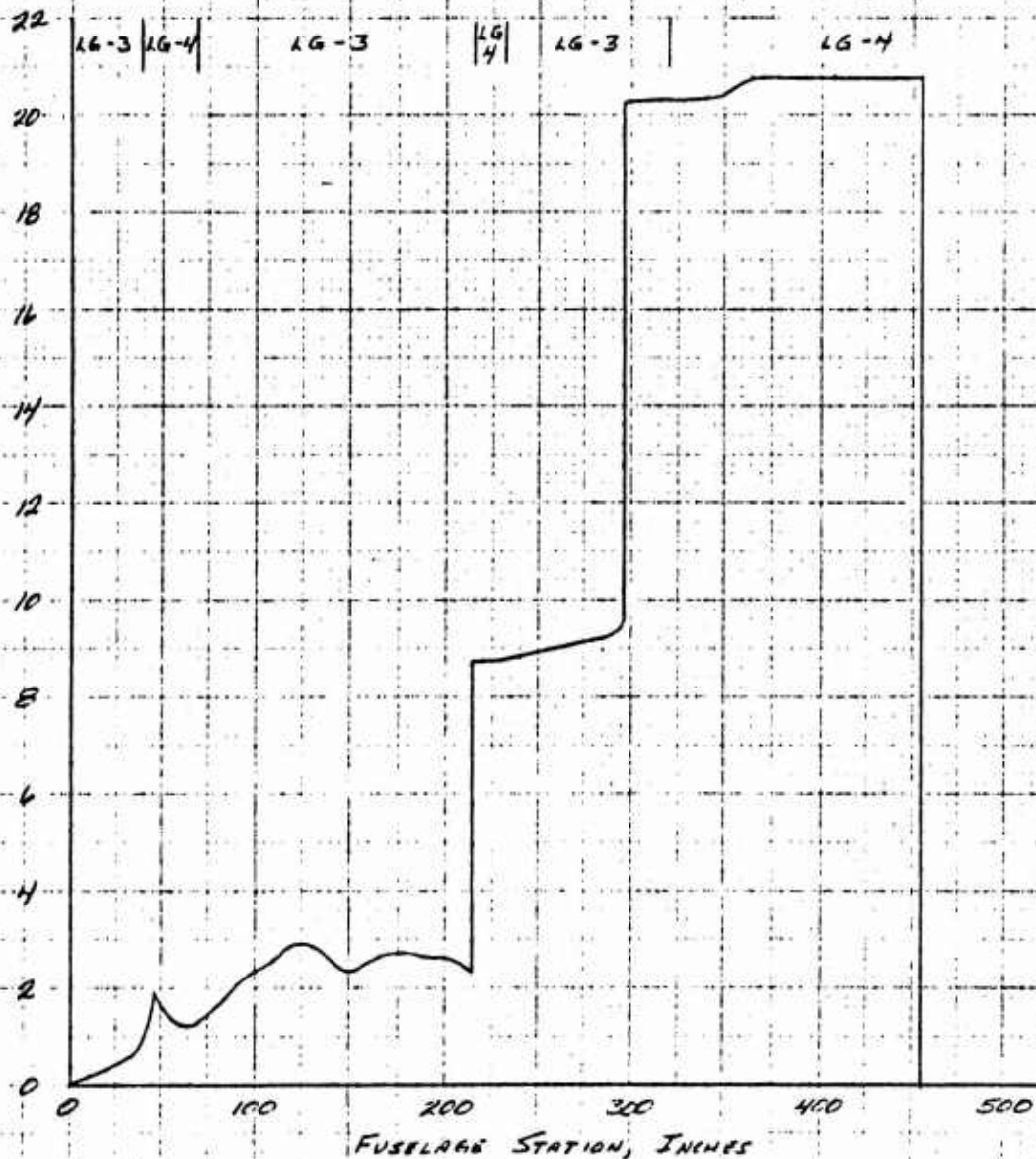

Figure 4.29 Fuselage Torsional Moment Envelope Curve Lateral Gust and Rudder Maneuver Conditions

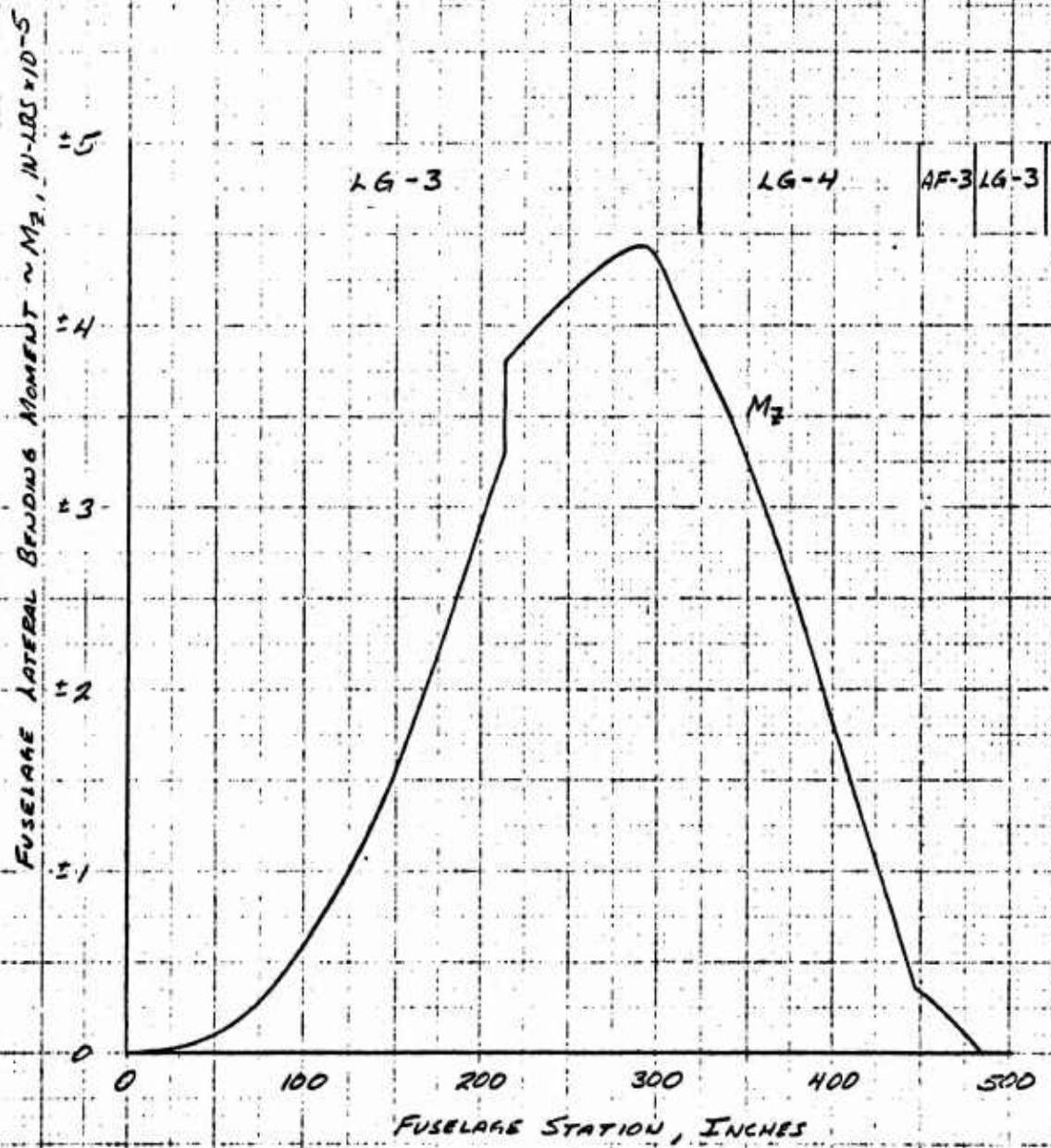

Figure 4.30 Fuselage Lateral Bending Moment Envelope Curve Rudder and Lateral Gust Loading Conditions

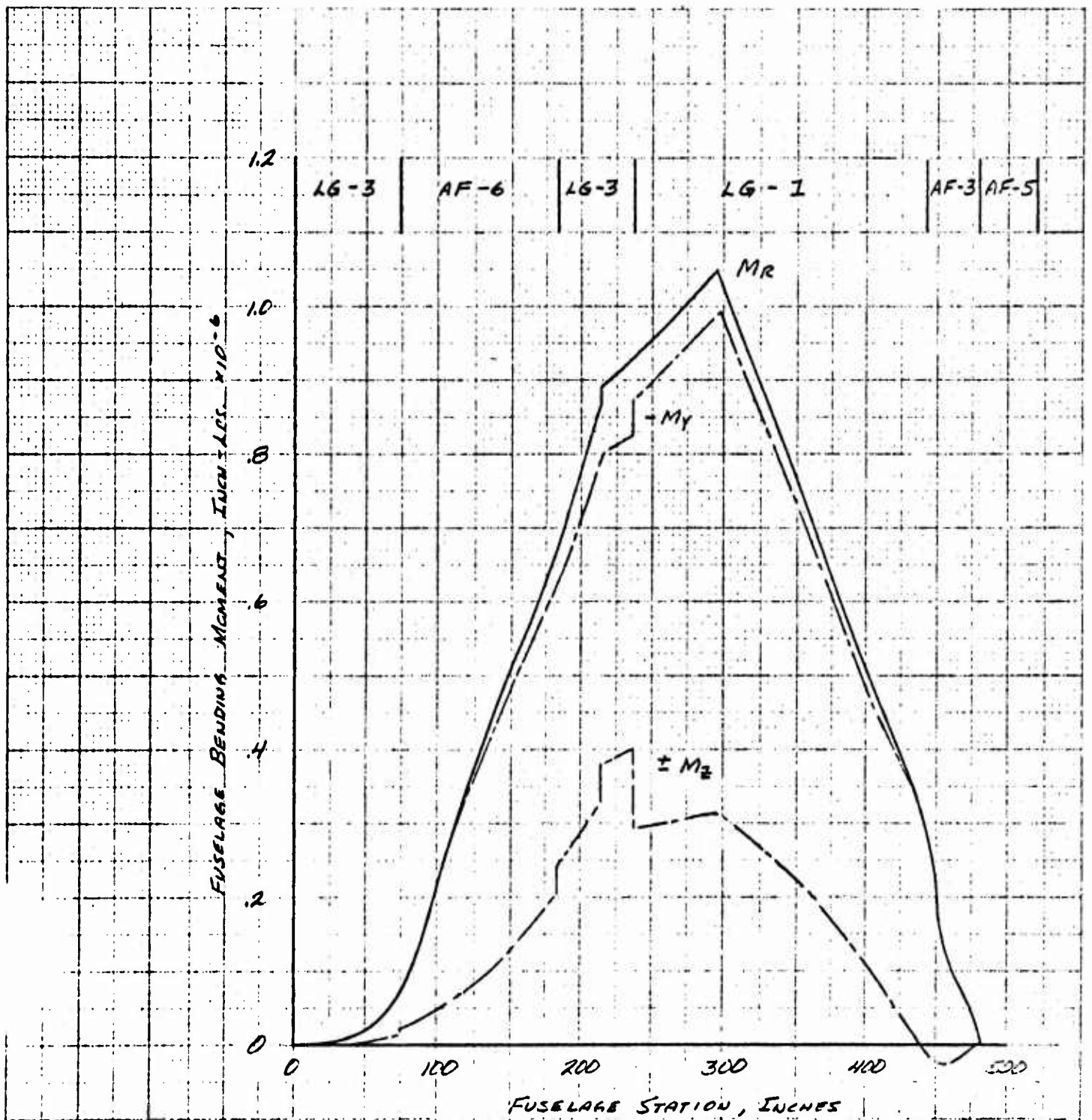

Figure 4.31 Fuselage Bending Moment Envelope Curves Rudder and Lateral Gust Conditions

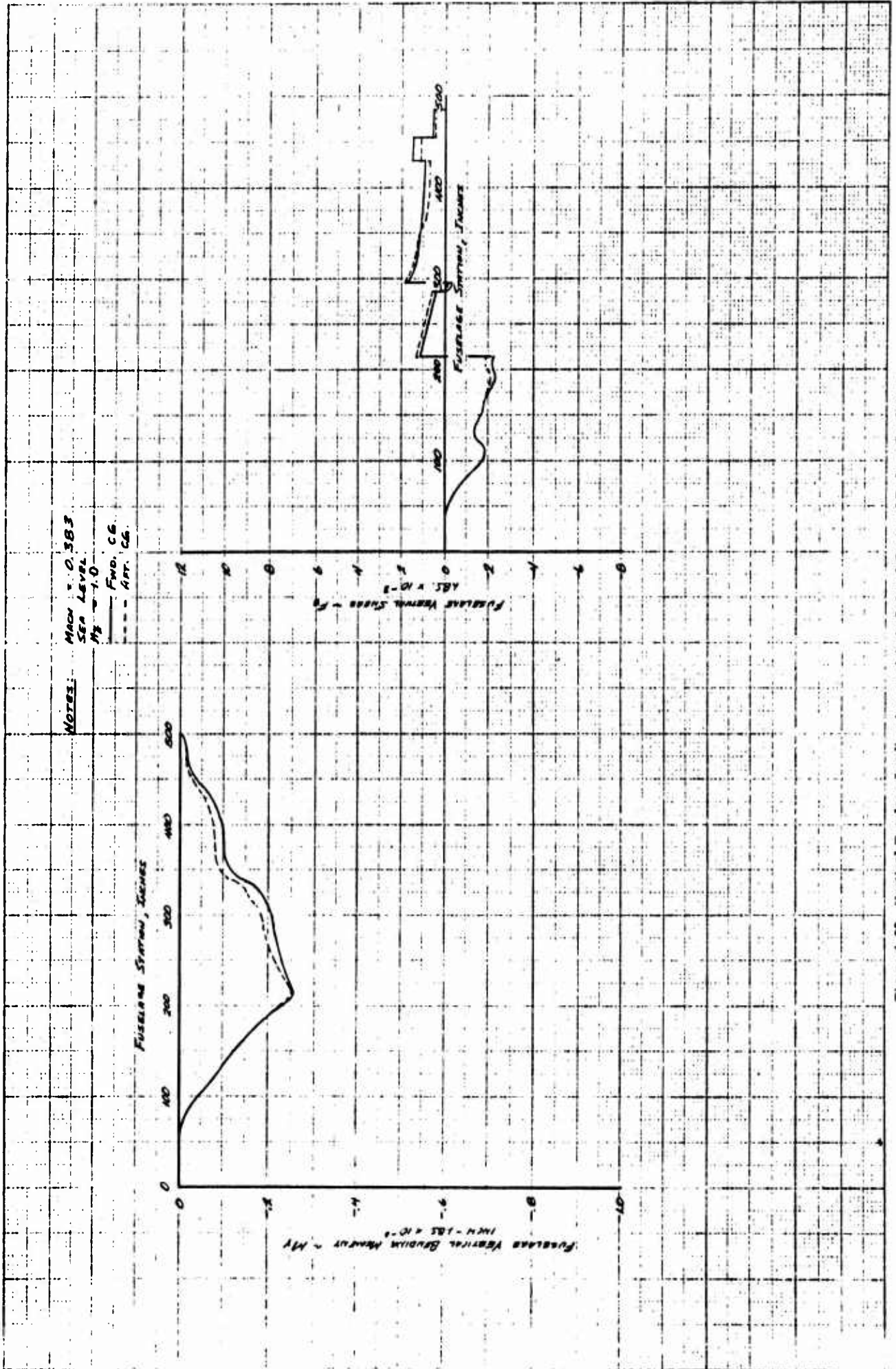

Figure 4.32 Vertical Fuselage Loading Appropriate to Lateral Gust and Rubber Conditions

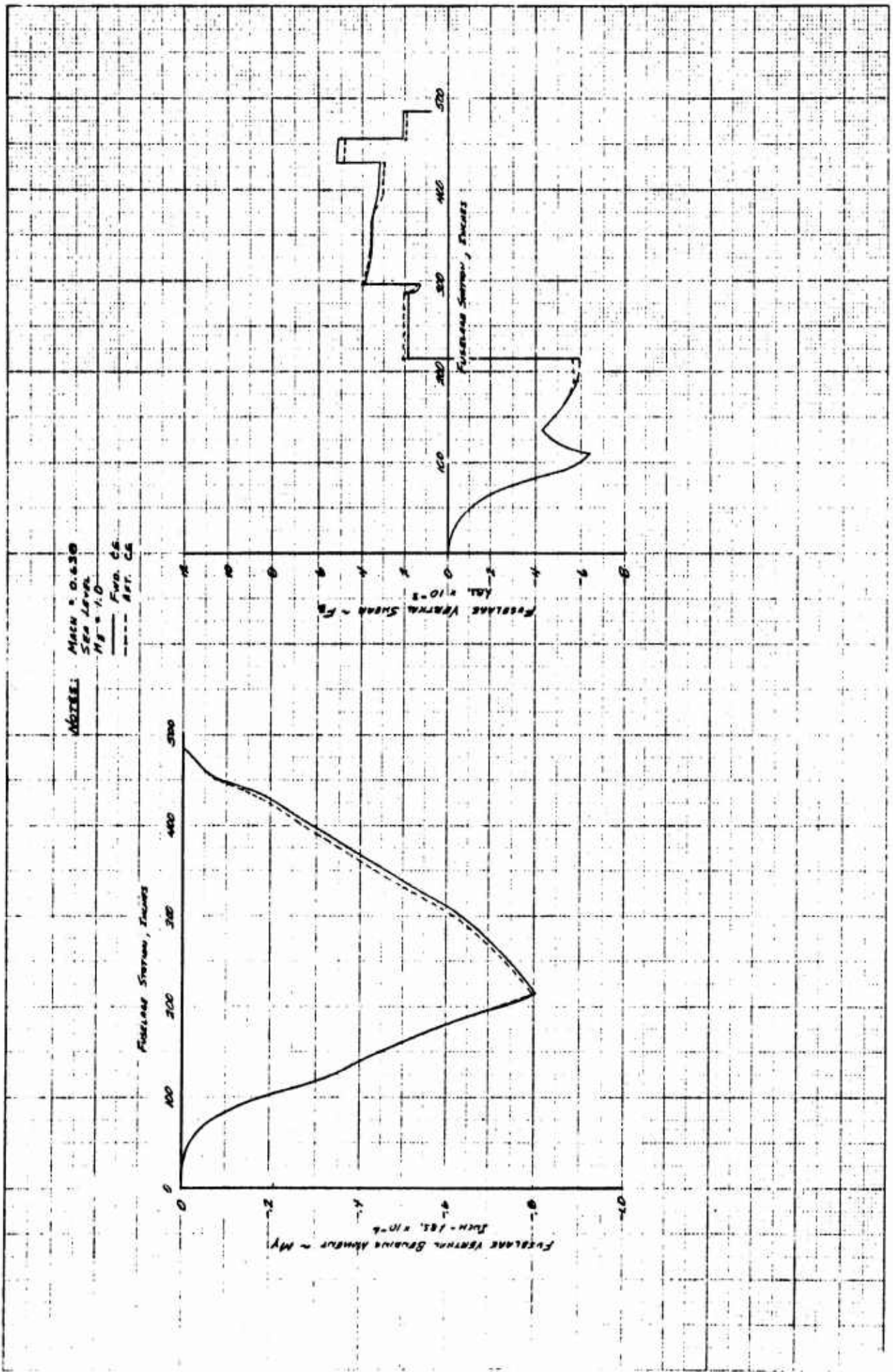

Figure 4.33 Vertical Fuselage Loading Appropriate to Lateral Gust and Rudder Conditions

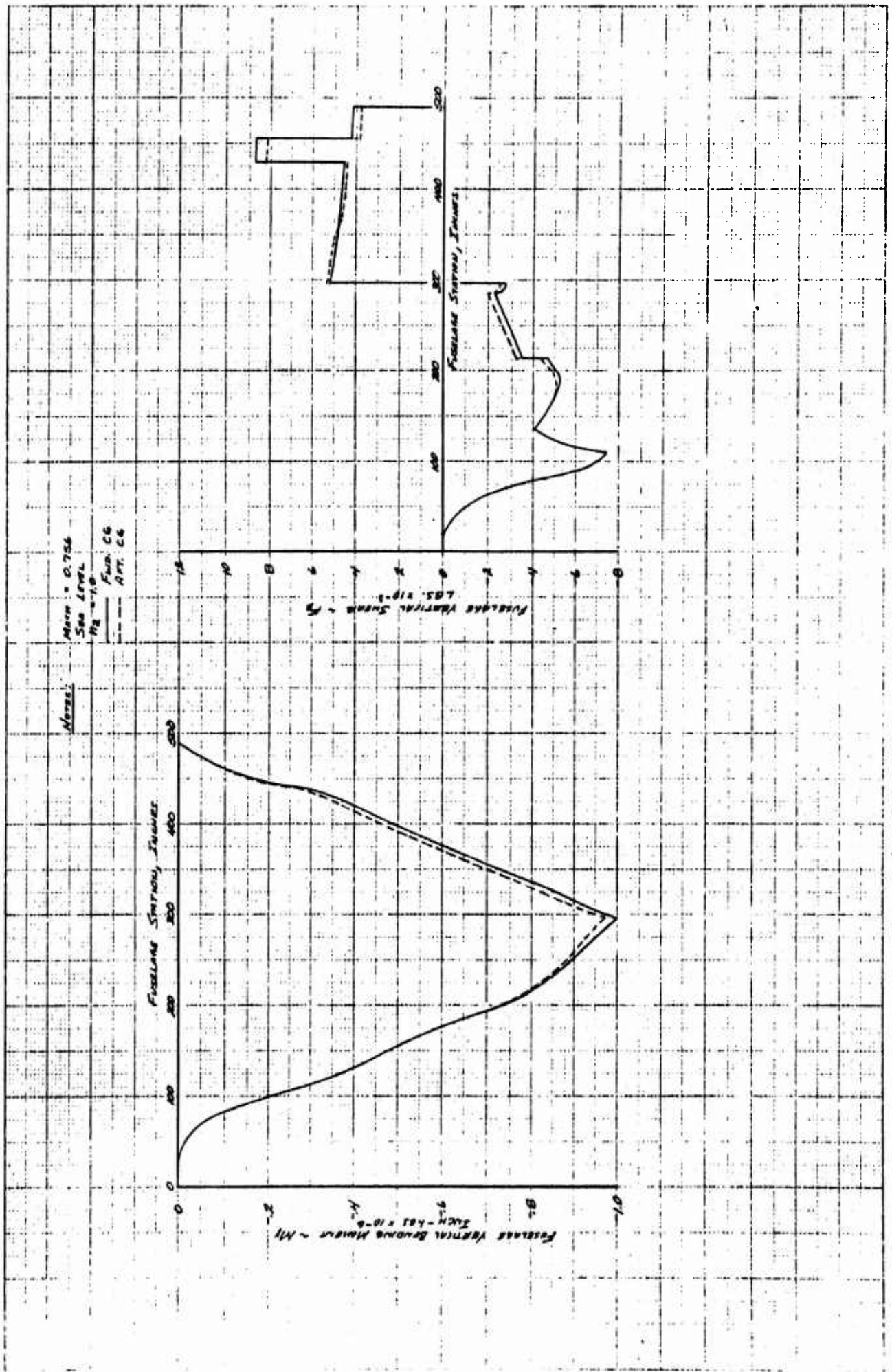

Figure 4.34 Vertical Fuselage Loading Appropriate to Lateral Gust and Rudder Conditions

ASYMMETRIC FLIGHT CONDITION LG-1

OUTPUT

F.S.	FX	FY	FZ	MX	MY	MZ
-70.00	0.	0.	0.	0.	0.	0.
0.	1.8677380E 00	-6.6099999E 00	4.2351969E 01	-1.9423098E 02	-6.2966466E 01	-1.0699421E 03
20.00	1.0761399E 02	-8.3067777E 01	2.2117686E 03	-4.5662352E 02	-1.0699421E 03	-3.4570144E 03
35.20	2.0503384E 02	-4.3492309E 02	4.1479952E 03	-4.0451407E 03	-6.4018482E 03	-1.0596492E 04
47.00	2.9062308E 02	-9.2999694E 02	5.6801699E 03	-1.1953431E 04	-1.6091258E 04	-2.2641464E 04
59.00	3.89329614E 02	-1.5403568E 03	6.2914044E 03	-2.6905599E 04	-2.8738441E 04	-4.5750923E 04
71.00	5.1371869E 02	-2.8027461E 03	8.0506048E 03	-5.3043633E 04	-4.5750923E 04	-5.8966849E 04
82.60	6.4584808E 02	-4.9431923E 03	1.0321350E 04	-9.5568736E 04	-7.873731E 04	-7.873731E 04
91.00	7.5719835E 02	-6.2315002E 03	1.2478120E 04	-1.4114040E 05	-9.7770686E 04	-1.2054141E 05
110.00	1.0276039E 03	-7.4267610E 03	1.5677988E 04	-2.7945285E 05	-1.4031198E 05	-1.5977900E 05
110.00	1.0276039E 03	-7.4267610E 03	1.5677988E 04	-2.7945285E 05	-1.4031198E 05	-1.5977900E 05
122.50	1.2110362E 03	-5.1759693E 03	1.7461427E 04	-3.6077484E 05	-1.873731E 04	-2.8738441E 04
136.50	1.3614972E 03	-4.0623813E 03	1.5757016E 04	-3.1908782E 05	-1.873731E 04	-2.8738441E 04
136.50	1.3614972E 03	-4.0623813E 03	1.5757016E 04	-3.1908782E 05	-1.873731E 04	-2.8738441E 04
150.00	1.4440048E 03	-4.8954645E 03	1.2224600E 04	-4.7770686E 05	-9.7770686E 04	-1.2054141E 05
165.20	1.6121961E 03	-4.8435587E 03	1.3923641E 04	-5.4844407E 05	-1.2054141E 05	-1.2054141E 05
177.20	1.6578279E 03	-5.1377704E 03	1.4127724E 04	-6.0870100E 05	-1.4031198E 05	-1.5977900E 05
188.90	1.6488613E 03	-5.2442629E 03	1.3066350E 04	-7.3642681E 05	-1.5977900E 05	-1.5977900E 05
201.90	1.6912054E 03	-4.9782099E 03	1.2525970E 04	-7.3642681E 05	-1.5977900E 05	-1.5977900E 05
214.00	1.5931434E 03	-4.7167961E 03	1.0039735E 04	-7.9463641E 05	-2.0199565E 05	-2.0199565E 05
214.00	8.45614369E 02	-3.4804513E 03	5.4342660E 04	-7.9463641E 05	-2.8848302E 05	-2.8848302E 05
266.00	-9.9373474E 00	-2.4410446E 02	-2.4433262E 03	-9.7575551E 05	-3.1636666E 05	-3.1636666E 05
266.00	-9.9373474E 00	-2.4410446E 02	-2.4433262E 03	-9.7575551E 05	-3.1636666E 05	-3.1636666E 05
287.00	-4.9710890E 02	-2.2317105E 03	5.4182952E 04	-9.7760041E 05	-3.1636666E 05	-3.1636666E 05
287.00	-4.9710890E 02	-2.2317105E 03	5.4182952E 04	-9.7760041E 05	-3.1636666E 05	-3.1636666E 05
296.50	-1.3875844E 05	5.1612855E 03	1.4468739E 05	-1.0003409E 06	-3.1516695E 05	-3.1516695E 05
315.89	-1.6636625E 03	5.0119867E 03	1.4496080E 05	-8.9973606E 05	-3.1516695E 05	-3.1516695E 05
328.10	-1.7270254E 03	4.9601399E 03	1.4481961E 05	-8.9973606E 05	-2.6695106E 05	-2.6695106E 05
341.00	-1.7728366E 03	4.8947067E 03	1.4457954E 05	-8.3879070E 05	-2.6662124E 05	-2.6662124E 05
366.00	-1.9230020E 03	4.7659551E 03	1.4359155E 05	-7.7476168E 05	-2.4371850E 05	-2.4371850E 05
392.12	-1.9727322E 03	4.5947067E 03	1.4329709E 05	-5.5037143E 05	-1.9578266E 05	-1.9578266E 05
392.12	-1.9727322E 03	4.5947067E 03	1.4329709E 05	-5.5037143E 05	-1.9578266E 05	-1.9578266E 05
407.00	-2.0355700E 03	4.6529039E 03	1.4322213E 05	-5.3037143E 05	-1.4367147E 05	-1.4367147E 05
419.00	-2.0453750E 03	4.5115327E 03	1.4292607E 05	-4.6088132E 05	-1.353265E 05	-1.353265E 05
429.23	-2.0726030E 03	4.5850399E 03	1.4276171E 05	-4.0523779E 05	-8.6241203E 04	-8.6241203E 04
429.23	-2.0726030E 03	4.5850399E 03	1.4276171E 05	-4.0523779E 05	-8.6241203E 04	-8.6241203E 04
446.35	-2.3765214E 03	8.7529632E 03	1.4284918E 05	-3.5821066E 05	-6.8241203E 04	-6.8241203E 04
446.35	-2.3765214E 03	8.7529632E 03	1.4284918E 05	-3.5821066E 05	-6.8241203E 04	-6.8241203E 04
455.22	-2.5886303E 03	8.7156610E 03	1.4287799E 05	-2.0684502E 05	-2.7366211E 04	-2.7366211E 04
455.22	-2.5886303E 03	8.7156610E 03	1.4287799E 05	-2.0684502E 05	-2.7366211E 04	-2.7366211E 04
470.80	-2.2469153E 02	4.2250542E 03	-1.0910547E 02	-1.3122728E 05	-6.7168047E 03	-6.7168047E 03
470.80	-2.2469153E 02	4.2250542E 03	-1.0910547E 02	-1.3122728E 05	-6.7168047E 03	-6.7168047E 03
486.39	-2.5092267E 02	4.1843653E 03	-1.8308472E 01	-6.5588328E 04	-3.4114121E 03	-3.4114121E 03
486.39	-2.5092267E 02	4.1843653E 03	-1.8308472E 01	-6.5588328E 04	-3.4114121E 03	-3.4114121E 03
486.39	2.5328365E 01	1.5441894E 01	-1.8308472E 01	-1.9507812E 02	2.6245117E 02	2.6245117E 02
500.00	9.1687546E 00	6.3004761E 00	-4.2222900E 00	-6.6628125E 01	9.1535303E 01	9.1535303E 01
520.00	-2.2125244E -04	4.8825125E -04	4.6496582E -01	1.40662500E -01	-2.81285062E -01	-2.81285062E -01

Table 4.48 Fuselage Loading Unsymmetrical Flight Maneuvers

FUSELAGE SHEAR AND MOMENT PROGRAM - JOB NUMBER 1105 - 13 MARCH 63

ASYMMETRIC FLIGHT CONDITION LG-3

OUTPUT

F.S.	FX	FY	FZ	MX	MY	MZ
-70.00	0.	0.	0.	0.	-0.	-0.
0.	5.9439373E 00	-6.4059599E 00	1.3486713E 02	1.9423098E 02	-1.9035581E 02	-1.9035581E 02
20.00	1.6461371E 02	-1.7657635E 02	3.3862066E 03	1.6694442E 03	-1.7745560E 03	-1.7745560E 03
35.00	3.0291042E 02	-5.6467377E 02	6.2554953E 03	7.2096910E 03	-5.3900535E 03	-5.3900535E 03
47.00	4.4811755E 02	-1.0193105E 03	9.8172244E 03	1.64433671E 04	-9.9167755E 03	-9.9167755E 03
59.00	6.2470450E 02	-1.6420364E 03	1.0253844E 04	3.1588201E 04	-1.6445395E 04	-1.6445395E 04
71.00	8.2515835E 02	-2.3933040E 03	1.3311048E 04	5.7088662E 04	-2.5343266E 04	-2.5343266E 04
82.00	1.0328867E 03	-4.0393114E 03	1.6986291E 04	9.5062257E 04	-3.6151787E 04	-3.6151787E 04
91.00	1.2069087E 03	-5.2733387E 03	2.0418115E 04	1.3409331E 05	-4.5525921E 04	-4.5525921E 04
110.00	1.6415686E 03	-6.3646600E 03	2.5859488E 04	2.5087631E 05	-7.2736366E 04	-7.2736366E 04
122.00	1.9357399E 03	-4.8792134E 03	2.9019759E 04	2.5087631E 05	-7.2736366E 04	-7.2736366E 04
136.00	2.2105750E 03	-4.3172517E 03	2.7487441E 04	5.8233599E 05	-1.2466334E 05	-1.2466334E 05
150.00	2.3961102E 03	-4.9125661E 03	2.3327644E 04	4.4561346E 05	-1.5618598E 05	-1.5618598E 05
165.00	2.6727910E 03	-5.2506278E 03	2.6364901E 04	5.2281315E 05	-1.9452311E 05	-1.9452311E 05
177.00	2.7808881E 03	-5.6061682E 03	2.7343335E 04	5.875350E 05	-2.2769155E 05	-2.2769155E 05
188.00	2.8005293E 03	-5.9128430E 03	2.6378051E 04	6.5542988E 05	-2.6076672E 05	-2.6076672E 05
201.00	2.8737121E 03	-5.9131367E 03	2.6037753E 04	7.3261949E 05	-2.5778044E 05	-2.5778044E 05
214.00	2.7168307E 03	-5.9343622E 03	2.5416946E 04	8.0383518E 05	-3.3263830E 05	-3.3263830E 05
214.00	1.6350566E 03	1.8618931E 03	8.6812679E 04	8.0383518E 05	-3.6042768E 05	-3.6042768E 05
286.00	2.0442129E 02	1.8225691E 03	9.2105956E 04	6.7425821E 05	-4.4270633E 05	-4.4270633E 05
287.00	-1.6945826E 02	1.5248958E 03	9.4222538E 04	6.7204075E 05	-4.4364978E 05	-4.4364978E 05
296.00	-5.8506451E 02	1.2578528E 03	9.5815333E 04	6.5663278E 05	-4.4319263E 05	-4.4319263E 05
315.00	-2.3395514E 03	3.6536973E 03	2.0311769E 05	5.8147917E 05	-4.0440723E 05	-4.0440723E 05
315.00	-2.3395514E 03	3.6536973E 03	2.0311769E 05	5.8147917E 05	-4.0440723E 05	-4.0440723E 05
328.00	-2.4445808E 03	3.5908060E 03	2.0304200E 05	5.3733966E 05	-3.7515578E 05	-3.7515578E 05
341.00	-2.5217935E 03	3.5374623E 03	2.0277426E 05	4.9132787E 05	-3.4326775E 05	-3.4326775E 05
366.00	-2.7695939E 03	3.3556847E 03	2.0133234E 05	4.075003E 05	-2.7457142E 05	-2.7457142E 05
392.00	-2.8594733E 03	3.2821644E 03	2.0095342E 05	3.1898587E 05	-1.9930867E 05	-1.9930867E 05
392.00	-2.8594733E 03	3.2821644E 03	2.0095342E 05	3.1898587E 05	-1.9930867E 05	-1.9930867E 05
407.00	-2.9162395E 03	3.2403615E 03	2.0113728E 05	2.7051794E 05	-1.5556612E 05	-1.5556612E 05
419.00	-2.9640960E 03	3.1992904E 03	2.0087670E 05	2.3132695E 05	-1.2026099E 05	-1.2026099E 05
429.00	-3.0308954E 03	3.1724975E 03	2.0039842E 05	1.9924555E 05	-8.9522624E 04	-8.9522624E 04
429.00	-3.0308954E 03	3.1724975E 03	2.0039842E 05	1.9924555E 05	-8.9522624E 04	-8.9522624E 04
446.00	-3.1315053E 03	3.143196E 03	2.0091642E 05	1.0938203E 05	-3.2676781E 04	-3.2676781E 04
455.00	-3.3327530E 03	3.1643739E 03	2.0065171E 05	6.4555500E 04	-3.8836836E 03	-3.8836836E 03
455.00	-3.3327530E 03	3.1643739E 03	2.0065171E 05	6.4555500E 04	-3.8836836E 03	-3.8836836E 03
470.00	-1.4104775E 02	2.0863379E 03	-2.1320117E 02	-3.2241125E 04	-2.0343555E 03	-2.0343555E 03
470.00	-1.4104775E 02	2.0863379E 03	-2.1320117E 02	-3.2241125E 04	-2.0343555E 03	-2.0343555E 03
486.00	-1.8699072E 02	2.6456191E 03	-1.0358594E 02	-1.9643750E 02	4.9871484E 02	4.9871484E 02
486.00	-1.8699072E 02	2.6456191E 03	-1.0358594E 02	-1.9643750E 02	4.9871484E 02	4.9871484E 02
500.00	1.6147255E 01	6.3001099E 00	-6.7963667E 00	-6.2312500E 01	1.6215625E 02	1.6215625E 02
520.00	-2.4098083E -03	1.2207031E -04	8.0078125E -02	6.2500000E -02	5.8593750E -01	5.8593750E -01

Table 4.49 Fuselage Loading Unsymmetrical Flight Manoeuvres

FUSELAGE SHEAR AND MOMENT PROGRAM - JOB NUMBER 1105 - 13 MARCH 63

ASYMMETRIC FLIGHT CONDITION LG-4

OUTPUT

F.S.	FX	FY	FZ	MX	MY	MZ
-70.00	0.	0.	-0.	0.	-0.	-0.
0.	4.7606083E 00	0.	-5.6099999E 00	1.0804635E 02	-1.9423098E 02	-1.5354020E 02
20.00	0.	1.6208696E 02	-1.5871942E 02	3.3338836E 03	-1.6894534E 03	-1.6965352E 03
35.20	0.	3.0584135E 02	-5.6653396E 02	6.1928537E 03	-7.2755369E 03	-5.2705415E 03
47.00	0.	9.6750127E 02	-1.0244141E 03	1.8922943E 04	-1.6562313E 04	-9.7214681E 03
59.00	0.	7.8576910E 02	-1.6493182E 03	1.2779373E 04	-3.2175432E 04	-1.6106987E 04
71.00	0.	6.2092133E 02	-2.6086792E 03	1.0186956E 04	-2.7357751E 04	-2.4697339E 04
82.60	0.	4.7644306E 02	-4.0476696E 03	8.2182146E 03	-5.85422758E 04	-3.5188770E 04
91.00	0.	1.1744507E 03	-5.2623592E 03	1.9882926E 04	-1.3452678E 04	-4.4343786E 04
110.00	0.	1.5974782E 03	-5.5762979E 03	2.5172710E 04	-2.85130129E 05	-7.0798129E 04
122.50	0.	1.8842539E 03	-4.6933405E 03	2.8252723E 04	-3.42363317E 05	-9.2714105E 04
136.50	0.	2.1429731E 03	-4.3346320E 03	2.6627060E 04	-3.68334506E 05	-1.2146564E 05
150.00	0.	2.1429731E 03	-4.3346320E 03	2.6627060E 04	-3.68334506E 05	-1.2146564E 05
165.20	0.	2.5824935E 03	-5.2623592E 03	2.5510446E 04	-5.24537254E 05	-1.8896712E 05
177.20	0.	2.7164092E 03	-5.7454981E 03	2.6872733E 04	-6.87252426E 05	-2.2095512E 05
188.90	0.	2.7787967E 03	-5.7624420E 03	2.6099121E 04	-6.8557489E 05	-2.5328638E 05
201.90	0.	2.9011398E 03	-5.9879588E 03	2.5856912E 04	-7.3033910E 05	-2.9033610E 05
214.00	0.	2.8198593E 03	-5.6114758E 03	2.2724220E 04	-7.9825900E 05	-3.5600563E 05
214.00	0.	1.8003287E 03	2.0874798E 03	8.7167270E 04	-7.9825900E 05	-3.5600563E 05
286.00	-0.	4.1740732E 02	2.0273344E 03	8.9315315E 04	-6.8254626E 05	-4.3208145E 05
286.00	-0.	4.1740732E 02	2.0273344E 03	8.9315315E 04	-6.8254626E 05	-4.3208145E 05
296.50	-0.	4.4497253E 01	1.7117054E 03	9.1678048E 04	-6.55010360E 05	-4.3337229E 05
296.50	-0.	-3.5369244E 02	1.4333667E 03	9.3585830E 04	-6.5290707E 05	-4.3470466E 05
315.89	-0.	-1.5855342E 03	4.0234644E 03	2.0183975E 05	-5.3250707E 05	-4.3470466E 05
315.89	-0.	-1.9985431E 03	3.7527661E 03	2.0293960E 05	-5.9562803E 05	-4.0200270E 05
328.10	-0.	-2.0981912E 03	3.5860578E 03	2.0293960E 05	-5.9562803E 05	-4.0200270E 05
341.00	-0.	-2.2240304E 03	3.0945046E 03	2.0381574E 05	-5.1048141E 05	-3.7697678E 05
366.00	-0.	-2.8103102E 03	3.1956850E 03	2.0738882E 05	-6.6344164E 05	-3.4931399E 05
392.12	-0.	-2.9521191E 03	3.0706637E 03	2.0738882E 05	-3.7697678E 05	-2.8448678E 05
392.12	-0.	-2.9521191E 03	3.0706637E 03	2.0738882E 05	-3.7697678E 05	-2.8448678E 05
407.00	-0.	-3.0030089E 03	3.025537E 03	2.0791155E 05	-2.9764650E 05	-2.0674267E 05
419.00	-0.	-3.0635894E 03	2.757987E 03	2.0815613E 05	-2.5232311E 05	-1.6164969E 05
429.23	-0.	-3.1054327E 03	2.9611568E 03	2.0781189E 05	-2.1516778E 05	-1.2534471E 05
446.55	-0.	-3.3708080E 03	2.8502142E 03	2.0760014E 05	-1.8574792E 05	-9.3817586E 04
455.22	-0.	-3.4180425E 03	4.6225185E 03	2.0779310E 05	-1.0198997E 05	-9.3817586E 04
455.22	-0.	-3.4180425E 03	4.6225185E 03	2.0779310E 05	-1.0198997E 05	-9.3817586E 04
470.80	-0.	-1.4277316E 02	1.9466779E 03	-2.5315234E 02	-6.0189719E 04	-5.3701914E 03
470.80	-0.	-1.8689371E 02	1.9248710E 03	-1.3147900E 02	-5.0057562E 04	-2.7679141E 03
486.39	-0.	-2.2840378E 02	1.4039591E 03	-4.6619336E 01	-1.9646875E 02	4.4800000E 02
486.39	-0.	3.6971615E 01	1.6441757E 01	-4.6619336E 01	-1.9646875E 02	4.4800000E 02
500.00	-0.	1.4545883E 01	3.3002350E 00	-1.3330566E 01	-9.02261250E 01	1.4489453E 02
520.00	-0.	-1.4190674E-03	3.5621374E-04	-4.3847656E-01	1.2500000E-01	-5.2343750E-01

Table 4.50 Fuselage Loading Unsymmetrical Flight Maneuvers

FUSELAGE SHEAR AND MOMENT PROGRAM - JOB NUMBER 1105 - 13 MARCH 63

ASYMMETRIC FLIGHT CONDITION AF-3

OUTPUT

S.S.	FX	FY	FZ	MX	MY	MZ
-70.00	0.	0.	0.	0.	0.	0.
0.	0.	0.	0.	0.	0.	0.
20.00	0.	1.2994320E 02	-8.3067777E 01	2.6679163E 03	-1.9423098E 02	1.3017719E 02
35.20	0.	2.5783503E 02	-4.3492309E 02	5.2116922E 03	-4.5682352E 02	-9.9501003E 02
47.00	0.	3.4475283E 02	-9.2999534E 02	6.7096723E 03	-4.0451407E 03	-3.9506899E 03
59.00	0.	4.2731336E 02	-1.6403688E 03	6.7265003E 03	-1.1953431E 04	-7.4662594E 03
71.00	0.	5.4572367E 02	-2.8027461E 03	8.3688558E 03	-2.6805599E 04	-1.2280583E 04
82.60	0.	6.9001651E 02	-4.6431925E 03	1.0860222E 04	-5.3849633E 04	-1.7897580E 04
91.00	0.	9.1986961E 02	-6.2315002E 03	1.3340525E 04	-1.4114040E 05	-3.1387221E 04
110.00	0.	1.1087282E 03	-7.6267610E 03	1.6591397E 04	-2.7945285E 05	-4.9847522E 04
122.50	0.	1.3066674E 03	-9.1737693E 03	1.6591397E 04	-2.7945285E 05	-4.9847522E 04
136.50	0.	1.3066674E 03	-9.1737693E 03	1.6591397E 04	-2.7945285E 05	-4.9847522E 04
136.50	0.	1.3994430E 03	-4.0623813E 03	1.5240662E 04	-3.6077484E 05	-6.4985475E 04
150.00	0.	1.3994430E 03	-4.0623813E 03	1.5240662E 04	-3.6077484E 05	-6.4985475E 04
165.20	0.	1.3697053E 03	-4.4954645E 03	1.6542942E 04	-4.1908782E 05	-6.4445366E 04
177.20	0.	1.5476922E 03	-5.1782692E 03	1.1782692E 04	-5.4844407E 05	-1.2468701E 05
188.90	0.	1.4570685E 03	-5.1377704E 03	1.1508383E 04	-6.0870100E 05	-1.4335095E 05
201.90	0.	1.5298785E 03	-5.2442629E 03	9.6513802E 03	-6.6960785E 05	-1.6117351E 05
214.00	0.	1.4067115E 03	-4.9782099E 03	8.8932143E 03	-7.3642681E 05	-1.8074642E 05
214.00	0.	5.4191528E 02	-4.7167961E 03	5.0674675E 03	-7.9463641E 05	-1.9896138E 05
286.00	0.	2.2140174E 02	-3.4804513E 03	4.9862929E 04	-7.9463641E 05	-2.3903893E 05
286.00	0.	2.2433262E 03	-2.2433262E 03	4.2588598E 04	-9.7575551E 05	-2.4755925E 05
287.00	0.	4.2487400E 02	-2.2317106E 03	4.3219573E 04	-9.7575551E 05	-2.4755925E 05
296.50	0.	6.3295666E 02	-2.7226789E 03	4.4123556E 04	-1.0003409E 06	-2.4403287E 05
296.50	0.	1.5570274E 03	5.1812855E 03	1.4045385E 05	-1.0003409E 06	-2.4403287E 05
315.89	0.	1.7597745E 03	5.0119661E 03	1.4114874E 05	-8.9973606E 05	-2.1291422E 05
328.10	0.	1.7597745E 03	5.0119661E 03	1.4114874E 05	-8.9973606E 05	-2.1291422E 05
341.00	0.	1.8940202E 03	4.9901395E 03	1.4123891E 05	-8.3879070E 05	-1.9113506E 05
366.00	0.	1.8940202E 03	4.9901395E 03	1.4123891E 05	-8.3879070E 05	-1.9113506E 05
392.12	0.	1.9032812E 03	4.7592505E 03	1.4127256E 05	-7.7476168E 05	-1.6788497E 05
392.12	0.	1.9032812E 03	4.7592505E 03	1.4127256E 05	-7.7476168E 05	-1.6788497E 05
427.00	0.	1.9140214E 03	4.6947067E 03	1.4138975E 05	-6.5401435E 05	-1.1930656E 05
419.00	0.	1.9140214E 03	4.6947067E 03	1.4138975E 05	-6.5401435E 05	-1.1930656E 05
429.23	0.	1.8464632E 03	4.5850393E 03	1.4141765E 05	-5.3037143E 05	-6.7917101E 04
429.23	0.	1.8464632E 03	4.5850393E 03	1.4141765E 05	-5.3037143E 05	-6.7917101E 04
446.55	0.	1.0131933E 03	8.7529632E 03	1.4141765E 05	-3.5821066E 05	-4.0764081E 03
446.55	0.	1.0131933E 03	8.7529632E 03	1.4141765E 05	-3.5821066E 05	-4.0764081E 03
455.22	0.	1.0131666E 03	8.7256010E 03	1.4145540E 05	-2.0684502E 05	2.1501504E 04
455.22	0.	9.6270608E 02	4.2250842E 03	1.4145540E 05	-1.3122728E 05	3.0314496E 04
470.80	0.	9.6935273E 02	4.2036775E 03	-7.0791016E 01	-1.3122728E 05	3.0314496E 04
486.39	0.	9.5641555E 02	4.1843555E 03	-4.3467005E 01	-6.5588328E 04	1.5129629E 04
486.39	0.	1.1014012E 01	1.8441695E 01	-1.9269371E 01	-1.9507812E 02	1.2926953E 02
500.00	0.	4.2220154E 00	6.3004761E 00	-1.9269371E 01	-1.9507812E 02	1.2926953E 02
520.00	0.	-3.33559336E -04	4.88261235E -04	-6.9001312E 00	-6.6828125E 01	4.2113281E 01
				5.8155823E -01	1.4062500E -01	7.6171875E -02

Table 4.51 Fuselage Loading Unsymmetrical Flight Maneuvers

FUSELAGE SHEAR AND MOMENT PROGRAM - JOB NUMBER 1105 - 13 MARCH 63

ASYMMETRIC FLIGHT CONDITION AF-5

OUTPUT

F.S.	FX	FY	FZ	MX	MY	MZ
-70.00	0.	0.	0.	0.	0.	0.
0.	-1.9244264E 00	-6.6099999E 00	-0.3639352E 01	-1.9423098E 02	5.2450783E 01	5.2450783E 01
20.00	1.3533477E 02	-8.3067777E 01	2.7793550E 03	-4.5682352E 02	-1.1559594E 03	-1.1559594E 03
35.00	2.6440074E 02	-6.3492309E 02	5.3452653E 03	-4.0451407E 03	-4.2047527E 03	-4.2047527E 03
47.00	3.6146299E 02	-5.2999694E 02	7.0365047E 03	-1.1953431E 04	-7.6816342E 03	-7.6816342E 03
59.00	4.6425077E 02	-1.6403689E 03	9.1867314E 03	-2.6905599E 04	-1.2997589E 04	-1.2997589E 04
71.00	5.9717070E 02	-2.6027461E 03	1.1866597E 04	-5.3049633E 04	-1.5260032E 04	-1.5260032E 04
82.60	7.5471721E 02	-4.6431925E 03	1.4466000E 04	-9.5568736E 04	-2.7116386E 04	-2.7116386E 04
91.00	6.9159925E 02	-6.2515002E 03	1.6069201E 04	-1.4114400E 05	-5.4025594E 04	-5.4025594E 04
110.00	1.2074652E 03	-7.4267610E 03	1.8069201E 04	-2.7945285E 05	-5.4095232E 04	-5.4095232E 04
110.00	1.2074652E 03	-7.4267610E 03	1.8069201E 04	-2.7945285E 05	-5.4095232E 04	-5.4095232E 04
122.50	1.4230677E 03	-4.0623815E 03	1.7077152E 04	-3.6077454E 05	-7.0613325E 04	-7.0613325E 04
136.50	1.5564075E 03	-4.0623813E 03	1.7077152E 04	-3.6077454E 05	-7.0613325E 04	-7.0613325E 04
150.00	1.5603162E 03	-4.4954645E 03	1.1864640E 04	-4.1908782E 05	-9.1988920E 04	-9.1988920E 04
165.00	1.7756405E 03	-4.6843556E 03	1.3750399E 04	-4.7770686E 05	-1.1267521E 05	-1.1267521E 05
177.00	1.7772711E 03	-5.1277704E 03	1.4298243E 04	-5.4484407E 05	-1.3653247E 05	-1.3653247E 05
188.50	1.7549140E 03	-5.2442629E 03	1.1766478E 04	-6.0870100E 05	-1.5990552E 05	-1.5990552E 05
201.90	1.6037502E 03	-4.9782094E 03	1.0371642E 04	-7.3642681E 05	-1.6078661E 05	-1.6078661E 05
214.00	1.6816186E 03	-4.7167961E 03	7.1094251E 03	-7.9463641E 05	-2.2556696E 05	-2.2556696E 05
214.00	8.2287426E 02	-3.4804513E 03	5.7039001E 04	-7.9463641E 05	-2.9208619E 05	-2.9208619E 05
286.00	-1.2843394E 02	-2.2433262E 03	5.0694951E 04	-9.7575551E 05	-3.1301375E 05	-3.1301375E 05
286.00	-1.2843394E 02	-2.2433262E 03	5.0694951E 04	-9.7575551E 05	-3.1301375E 05	-3.1301375E 05
287.00	-1.7064493E 02	-2.5317108E 03	5.1999601E 04	-9.7760041E 05	-3.1329474E 05	-3.1329474E 05
296.50	-6.2918544E 02	-4.7225785E 03	5.2439579E 04	-1.0003409E 06	-3.1036781E 05	-3.1036781E 05
296.50	-1.6566784E 03	5.1812853E 03	1.6146662E 05	-1.0003409E 06	-3.1036781E 05	-3.1036781E 05
315.89	-1.5330736E 03	5.0119867E 03	1.6194602E 05	-8.5973606E 05	-2.7661018E 05	-2.7661018E 05
315.89	-1.9350736E 03	5.0119867E 03	1.6194602E 05	-8.5973606E 05	-2.7661018E 05	-2.7661018E 05
328.10	-1.9873087E 03	4.9301399E 03	1.6185726E 05	-8.3387907E 05	-2.5200763E 05	-2.5200763E 05
341.00	-2.0226571E 03	4.9392505E 03	1.6174780E 05	-7.7476168E 05	-2.2599537E 05	-2.2599537E 05
365.00	-2.1506807E 03	4.7659951E 03	1.6125002E 05	-6.5401459E 05	-1.7255500E 05	-1.7255500E 05
392.12	-2.1819789E 03	4.6947067E 03	1.6104087E 05	-5.3037143E 05	-1.1422597E 05	-1.1422597E 05
392.12	-2.1819789E 03	4.6947067E 03	1.6104087E 05	-5.3037143E 05	-1.1422597E 05	-1.1422597E 05
407.00	-2.2054624E 03	4.6529039E 03	1.6097943E 05	-4.6088132E 05	-8.0818378E 04	-8.0818378E 04
419.00	-2.2373255E 03	4.6115327E 03	1.6077654E 05	-4.0523779E 05	-5.4245375E 04	-5.4245375E 04
429.23	-2.2589990E 03	4.5850399E 03	1.6069329E 05	-3.5821066E 05	-3.1266197E 04	-3.1266197E 04
429.23	-1.7773063E 03	8.7529632E 03	1.6069329E 05	-3.5821066E 05	-3.1266197E 04	-3.1266197E 04
446.55	-1.6632886E 03	8.7296079E 03	1.6074624E 05	-2.06884502E 05	4.0571459E 04	4.0571459E 04
455.22	-1.6500771E 03	8.7156610E 03	1.6076611E 05	-1.3122728E 05	1.5562609E 04	1.5562609E 04
455.22	5.2466660E 02	4.2250942E 03	-9.3460337E 01	-1.3122728E 05	1.5862809E 04	1.5862809E 04
470.80	5.0164542E 02	4.2036772E 03	-2.2715705E 01	-6.5588928E 04	7.6877653E 03	7.6877653E 03
486.39	4.8034423E 02	4.1843655E 03	-2.0665586E 01	-1.9507612E 02	2.2337109E 02	2.2337109E 02
486.39	1.8550429E 01	1.6441894E 01	-2.0665586E 01	-1.9507612E 02	2.2337109E 02	2.2337109E 02
500.00	7.2644424E 00	6.3004761E 00	-5.3557047E 00	-6.6828125E 01	7.6507422E 01	7.6507422E 01
520.00	-5.1116945E -04	4.6828125E -04	8.0131836E -01	1.40682500E -01	3.7109375E -02	3.7109375E -02

Table 4.52 Fuselage Loading Unsymmetrical Flight Maneuvers

ASYMMETRIC FLIGHT CONDITION AF-6

OUTPUT

F.S.	FX	FY	FZ	MX	MY	MZ
-70.00	0.	0.	0.	0.	0.	-0.
0.	-2.9106164E 00	-6.6099999E 00	-5.5981324E 01	-1.9423098E 02	8.1747602E 01	8.1747602E 01
20.00	0.	0.	0.	0.	0.	0.
35.20	0.	0.	0.	0.	0.	0.
47.00	0.	0.	0.	0.	0.	0.
59.00	0.	0.	0.	0.	0.	0.
71.00	0.	0.	0.	0.	0.	0.
83.50	0.	0.	0.	0.	0.	0.
91.00	0.	0.	0.	0.	0.	0.
110.00	0.	0.	0.	0.	0.	0.
115.00	0.	0.	0.	0.	0.	0.
122.50	0.	0.	0.	0.	0.	0.
136.50	0.	0.	0.	0.	0.	0.
146.50	0.	0.	0.	0.	0.	0.
155.00	0.	0.	0.	0.	0.	0.
177.00	0.	0.	0.	0.	0.	0.
188.00	0.	0.	0.	0.	0.	0.
214.00	0.	0.	0.	0.	0.	0.
214.00	0.	0.	0.	0.	0.	0.
226.00	0.	0.	0.	0.	0.	0.
286.00	0.	0.	0.	0.	0.	0.
287.00	0.	0.	0.	0.	0.	0.
346.50	0.	0.	0.	0.	0.	0.
315.89	0.	0.	0.	0.	0.	0.
315.89	0.	0.	0.	0.	0.	0.
326.10	0.	0.	0.	0.	0.	0.
341.00	0.	0.	0.	0.	0.	0.
366.00	0.	0.	0.	0.	0.	0.
392.12	0.	0.	0.	0.	0.	0.
392.12	0.	0.	0.	0.	0.	0.
415.00	0.	0.	0.	0.	0.	0.
429.23	0.	0.	0.	0.	0.	0.
429.23	0.	0.	0.	0.	0.	0.
446.55	0.	0.	0.	0.	0.	0.
455.22	0.	0.	0.	0.	0.	0.
470.50	0.	0.	0.	0.	0.	0.
486.39	0.	0.	0.	0.	0.	0.
486.39	0.	0.	0.	0.	0.	0.
500.00	0.	0.	0.	0.	0.	0.
520.00	0.	0.	0.	0.	0.	0.

Table 4.53 Fuselage Loading Unsymmetrical Flight Maneuvers

4.5.3 Rolling Pullout

Table 4.55 summarizes the loads and flight conditions of four rolling-pullout maneuvers which were chosen for detailed study. Fuselage distributed loads for these four conditions are given in Tables 4.56 through 4.59. Graphical presentations of the fuselage loads are shown in Figures 4.35 and 4.36. The resultant bending moment envelope curve shown in Figure 4.36 was determined from

$$M_R = \sqrt{M_y^2 + M_z^2}$$

The vertical bending moment M_y and lateral bending moment M_z curves shown on the same figure present the values of these parameters which produce the M_R envelope and are not necessarily the maximum values of these parameters at any given fuselage station.

XV-5A ROLLING - PULLOUT MANEUVER

$\delta a_{total} = -34^\circ$ AFT CA

Roll Curves by Level Sweep

COND. No.	MACH No.	ALTITUDE (FEET)	NZ	NY	$\dot{\phi}$ (DEG/SEC)	$\ddot{\psi}$ (DEG/SEC ²)	P (DEG/SEC)	R (DEG/SEC)	VERT. TAIL FORCE (LBS.)	V. TAIL CP STR. (IN.)	V. TAIL CP STR. (IN.)	V. TAIL WLL (IN.)	HOR. TAIL M ₂ (IN.-LBS.)	BODY SIDE FORCE (LBS.)	WING M ₂ (IN.-LBS.)
Roll-3	.5	0	1.1	.77	-2.52	1.37	-200	-6.1	3443	461.8	158.7	22016	4254	-3275	
Roll-4	.5	0	2.5	.26	-5.37	.48	-150	-5.6	1321	461.1	157.5	36844	1798	-257817	
Roll-5	.756	15,000	1.1	.73	-1.27	.86	-150	-2.7	3138	466.1	159.1	-14474	3593	88461	
Roll-6	.756	15,000	2.5	.23	-2.09	.24	-130	-2.7	1058	465.2	157.6	23664	1053	-85845	

Table 4.55 XV-5A Rolling - Pullout Maneuver

ASYMMETRIC FLIGHT CONDITION ROLL 3

OUTPUT

F.S.	FX	FY	FZ	MX	MY	MZ
-70.00	0.0	0.0	0.0	9.0	0.0	-0.0
0.0	1.9418653E 00	-7.2709998E 00	4.4177133E 01	-2.1365407E 02	-6.6069031E 01	0.0
20.00	1.5196645E 02	-9.0796322E 01	3.1254673E 03	-9.2920215E 02	-1.4784066E 03	0.0
35.20	2.9063332E 02	-2.6821798E 02	5.8849698E 03	-3.5392132E 03	-4.8570456E 03	0.0
47.00	9.2366984E 02	-5.1116288E 02	1.8073346E 04	-8.0883751E 03	-9.0164074E 03	0.0
59.00	7.2421386E 02	-8.6425956E 02	1.1831559E 04	-1.5943971E 04	-1.4907816E 04	0.0
71.00	5.4536089E 02	-1.3728332E 03	9.0682961E 03	-2.9366665E 04	-2.2557438E 04	0.0
82.60	3.9216385E 02	-2.1138947E 03	6.9510610E 03	-4.9327981E 04	-3.2000967E 04	0.0
91.00	1.0636804E 03	-2.7099373E 03	1.8159446E 04	-6.9327981E 04	-4.0272235E 04	0.0
110.00	1.4447495E 03	-3.4429394E 03	2.2963276E 04	-1.3043904E 05	-6.4240841E 04	0.0
110.00	1.4447495E 03	-3.4429394E 03	2.2963276E 04	-1.3043904E 05	-6.4240841E 04	0.0
122.50	1.7032860E 03	-3.0184641E 03	2.5795889E 04	-1.7144625E 05	-8.4034362E 04	0.0
136.50	1.9057724E 03	-2.7945023E 03	2.4072544E 04	-2.1087085E 05	-1.0985568E 05	0.0
136.50	1.9057724E 03	-2.7945023E 03	2.4072544E 04	-2.1087085E 05	-1.0985568E 05	0.0
150.00	1.9988666E 03	-3.1384045E 03	2.0141774E 04	-2.5177329E 05	-1.3601065E 05	0.0
165.20	2.2450477E 03	-3.2938503E 03	2.2972272E 04	-3.0050469E 05	-1.6841150E 05	0.0
177.20	2.3506224E 03	-3.4993211E 03	2.4201165E 04	-3.4128628E 05	-1.9613192E 05	0.0
188.50	2.3878020E 03	-3.6838225E 03	2.3518091E 04	-3.8326498E 05	-2.2400596E 05	0.0
201.90	2.4981033E 03	-3.6010812E 03	2.3385612E 04	-4.3084286E 05	-2.5584832E 05	0.0
214.00	2.4096007E 03	-3.5794598E 03	2.0623075E 04	-4.7376494E 05	-2.8632528E 05	0.0
214.00	1.4949869E 03	2.3949677E 03	5.5633777E 04	-4.7376494E 05	-3.5136268E 05	0.0
286.00	1.8384619E 02	1.3361165E 03	5.8565283E 04	-3.2860347E 05	-4.0585914E 05	0.0
286.00	1.8384619E 02	1.3361165E 03	5.8565283E 04	-3.2860347E 05	-4.0585914E 05	0.0
287.00	-1.4540826E 02	9.5857403E 02	6.0744586E 04	-3.2682231E 05	-4.0674453E 05	0.0
296.50	-4.8830844E 02	4.2044494E 02	6.2604122E 04	-3.1785878E 05	-4.0613753E 05	0.0
296.50	-1.5933851E 03	2.7778478E 03	9.3329666E 04	-3.1785878E 05	-3.9376121E 05	0.0
315.89	-1.9379389E 03	2.2560727E 03	9.4656173E 04	-2.7123176E 05	-3.6123253E 05	0.0
315.89	-1.9379389E 03	2.2560727E 03	9.4656173E 04	-2.7123176E 05	-3.6123253E 05	0.0
328.10	-2.0164243E 03	2.1549601E 03	9.4968462E 04	-2.44400690E 05	-3.3705814E 05	0.0
341.00	-2.1167372E 03	2.0398190E 03	9.5686507E 04	-2.1034169E 05	-3.1056425E 05	0.0
366.00	-2.5947556E 03	1.6012315E 03	9.8956039E 04	-1.6428962E 05	-2.4973633E 05	0.0
392.12	-2.7024603E 03	1.4860387E 03	9.9512253E 04	-1.3035423E 05	-1.7817493E 05	0.0
392.12	-2.7024603E 03	1.4860387E 03	9.9512253E 04	-1.3035423E 05	-1.7817493E 05	0.0
407.00	-2.7395430E 03	1.4492388E 03	9.9908262E 04	-1.10103594E 05	-1.3692188E 05	0.0
419.00	-2.7849959E 03	1.4114667E 03	9.9761752E 04	-9.3827093E 04	-1.0384335E 05	0.0
429.23	-2.8165296E 03	1.3883266E 03	9.9654217E 04	-7.5754046E 04	-7.5216094E 04	0.0
429.23	-2.8165296E 03	1.3883266E 03	9.9654217E 04	-7.5754046E 04	-7.5216094E 04	0.0
446.55	-2.9795809E 03	2.0466306E 03	9.9823102E 04	-7.5754046E 04	-2.5064531E 04	0.0
455.22	-2.9306920E 03	2.0202988E 03	9.9878081E 04	-4.5054609E 04	2.7192969E 02	0.0
455.22	3.1978271E 01	7.0429285E 02	-2.279558E 02	-2.3834156E 04	2.7192969E 02	0.0
470.80	-2.4590454E 00	6.8555902E 02	-1.2013916E 02	-1.3029719E 04	6.9578125E 01	0.0
486.39	-3.4623901E 01	6.6912988E 02	-4.4207519E 01	-3.5135156E 03	3.4325390E 02	0.0
486.39	2.8427483E 01	1.0825859E 01	-4.4207519E 01	-3.5135156E 03	3.4325390E 02	0.0
500.00	1.1137505E 01	3.8546143E 00	-1.3133301E 01	-4.8250000E 01	1.1135156E 02	0.0
520.00	-3.7384033E-04	8.5449219E-04	4.8828125E-04	2.1875000E-01	1.0156250E-01	0.0

Table 4.56 Fuselage Loading Unsymmetrical Flight Maneuvers

FUSELAGE SHEAR AND MOMENT PROGRAM - JOB NUMBER 1105 - 23 AUGUST 63

ASYMMETRIC FLIGHT CONDITION ROLL 4

OUTPUT

F.S.	FX	FY	FZ	MX	MY	MZ
-70.00	0.	0.	0.	0.	0.	0.
0.	2.173198E 00	0.	-1.6525000E 01	4.9646763E 01	-4.8557744E 02	-6.6963913E 01
35.20	0.	6.7143553E 01	-2.7597915E 01	1.3866350E 03	-8.3616995E 02	-7.0836396E 02
47.00	0.	1.2646267E 02	-1.2708734E 02	2.5736578E 03	-1.9039594E 03	-2.01870296E 03
59.00	0.	4.0092354E 02	-3.5639707E 02	7.9907999E 03	-4.7200570E 03	-4.0433585E 03
71.00	0.	3.2670206E 02	-7.5626599E 02	5.9982525E 03	-1.0566994E 04	-6.6826863E 03
82.60	0.	2.6088324E 02	-1.2914953E 03	5.3822301E 03	-2.3220403E 04	-1.0246946E 04
91.00	0.	2.0530936E 02	-2.0369437E 03	4.8370425E 03	-4.2222395E 04	-1.4634630E 04
110.00	0.	4.9672491E 02	-2.6334425E 03	9.8637718E 03	-6.1784136E 04	-1.8490426E 04
122.50	0.	6.7756288E 02	-3.4657305E 03	1.2833028E 04	-1.2174902E 05	-2.9725314E 04
136.50	0.	7.9965745E 02	-3.1261891E 03	1.4895361E 04	-1.6335757E 05	-3.9003644E 04
150.00	0.	9.0225306E 02	-3.2744212E 03	1.6015808E 04	-2.0608632E 05	-5.1152014E 04
165.20	0.	9.4330224E 02	-3.2744212E 03	1.6015808E 04	-2.0608632E 05	-5.1152014E 04
177.20	0.	1.0693509E 03	-4.5968741E 03	1.9011646E 04	-3.2583525E 05	-7.8827714E 04
188.90	0.	1.138172E 03	-5.1566803E 03	2.0743682E 04	-3.8431276E 05	-9.2100666E 04
201.90	0.	1.1621966E 03	-5.7149610E 03	2.1963154E 04	-4.4777492E 05	-1.0565295E 05
214.00	0.	1.2021434E 03	-5.7351358E 03	2.2874356E 04	-5.2264501E 05	-1.2107035E 05
228.00	0.	1.1162480E 03	-5.9440019E 03	2.4279669E 04	-5.9205135E 05	-1.3560011E 05
241.00	0.	9.0938201E 02	5.3695520E 03	3.4401792E 05	-5.9205135E 05	-1.5819170E 05
256.00	-0.	7.2192173E 01	2.3711236E 03	3.6262614E 05	-3.3407304E 05	-1.8560174E 05
266.00	-0.	7.2192173E 01	2.3711236E 03	3.6262614E 05	-3.3407304E 05	-1.8560174E 05
287.00	-0.	-7.5897060E 01	1.5409919E 03	3.6466949E 05	-3.3067705E 05	-1.8605746E 05
296.50	-0.	-2.1415190E 02	3.629882E 02	3.6643673E 05	-3.1525653E 05	-1.8563534E 05
315.89	-0.	-4.6409647E 02	3.8941059E 03	-1.7446523E 04	-3.1525653E 05	-1.1781058E 05
315.89	-0.	-5.8197586E 02	2.8781646E 03	-1.5595407E 04	-2.6289292E 05	-1.0823916E 05
328.10	-0.	-5.8197586E 02	2.8781646E 03	-1.5595407E 04	-2.6289292E 05	-1.0823916E 05
341.00	-0.	-6.0358075E 02	2.6360176E 03	-1.4780097E 04	-2.2755750E 05	-1.0099029E 05
366.00	-0.	-8.4214807E 02	2.3635564E 03	-1.3671187E 04	-1.6343084E 05	-9.3032686E 04
392.12	-0.	-8.4214807E 02	1.3980326E 03	-9.8566937E 03	-1.1297622E 05	-7.3694971E 04
392.12	-0.	-8.8173815E 02	1.1157297E 03	-8.9041464E 03	-1.1004669E 05	-5.0103581E 04
407.00	-0.	-8.9146881E 02	1.1157297E 03	-8.9041464E 03	-1.1004669E 05	-5.0103581E 04
419.00	-0.	-9.0218902E 02	1.0204055E 03	-7.7433798E 03	-1.0171159E 05	-3.6598189E 04
429.23	-0.	-9.1067501E 02	9.2513403E 02	-7.4525058E 03	-9.44474062E 04	-2.5854643E 04
429.23	-0.	-9.7972303E 02	8.6448376E 02	-7.3654628E 03	-6.7086406E 04	-1.6594336E 04
446.55	-0.	-8.1143266E 02	1.4937898E 03	-7.3654628E 03	-6.7086406E 04	-1.6594336E 04
455.22	-0.	-8.1722753E 02	1.4361024E 03	-7.1960734E 03	-6.3965750E 04	-2.6792060E 04
455.22	-0.	-8.1722753E 02	1.4152347E 03	-7.1481181E 03	-6.3965750E 04	-2.6792060E 04
470.80	-0.	1.4956554E 02	7.5535235E 02	-1.7350781E 02	-3.3796594E 04	4.3776562E 03
486.39	-0.	1.3629286E 02	7.0668880E 02	-8.2538574E 01	-3.3796594E 04	4.3776562E 03
500.00	-0.	1.2406843E 02	6.6318322E 02	-2.7030273E 01	-1.6850031E 04	1.2728320E 02
520.00	-0.	1.0616444E 01	3.3877151E 01	-2.7030273E 01	-1.6850031E 04	1.2728320E 02
		4.1250736E 00	1.2707764E 01	-6.8374023E 00	-1.3578125E 02	4.05991211E 01
		-1.1711121E-03	1.3427734E-03	2.4414062E-03	4.3750000E-01	4.0039062E-02

Table 4.57 Fuselage Loading Unsymmetrical Flight Maneuvers

ASYMMETRIC FLIGHT CONDITION ROLL 5

OUTPUT

F.S.	FX	FY	FZ	MX	MY	MZ
-70.00	0.	0.	0.	0.	0.	0.
0.	-2.8598967E-01	-7.2709998E 00	-6.4045246E 00	-2.1365407E 02	-2.1365407E 02	2.7774380E 00
20.00	1.2414380E 02	-1.2719343E 01	2.5518165E 03	-8.2101501E 01	-8.2101501E 01	-1.1255887E 03
35.20	0.	2.4030943E 02	-1.8306883E 02	4.8629816E 03	-1.3675786E 03	-3.9083331E 03
47.00	0.	3.3288213E 02	-4.6342472E 02	6.5292709E 03	-5.1042910E 03	-7.2913546E 03
59.00	0.	4.3460565E 02	-8.9302435E 02	7.0662911E 03	-1.2807895E 04	-1.2034125E 04
71.00	0.	5.6189989E 02	-1.5783109E 03	8.9981844E 03	-2.7472971E 04	-1.7967937E 04
82.60	0.	7.0908813E 02	-2.6485520E 03	1.1562670E 04	-5.1584647E 04	-2.5358206E 04
91.00	0.	8.3590565E 02	-3.5707445E 03	1.4037778E 04	-7.7637913E 04	-3.1646001E 04
110.00	0.	1.1311764E 03	-4.2906282E 03	1.7626136E 04	-1.5720937E 05	-5.0664287E 04
110.00	0.	1.1311764E 03	-4.2906282E 03	1.7626136E 04	-1.5720937E 05	-5.0664287E 04
122.50	0.	1.3314848E 03	-2.29988275E 03	1.9685462E 04	-2.0425764E 05	-6.6160308E 04
136.50	0.	1.4608102E 03	-2.24675360E 03	1.7663650E 04	-2.3847515E 05	-8.6192542E 04
136.50	0.	1.4608102E 03	-2.24675360E 03	1.7663650E 04	-2.3847515E 05	-8.6192542E 04
150.00	0.	1.4857040E 03	-2.29228185E 03	1.3810218E 04	-2.7592364E 05	-1.0571945E 05
165.20	0.	1.6700248E 03	-3.2171137E 03	1.5836287E 04	-3.2233884E 05	-1.2982578E 05
177.20	0.	1.7291293E 03	-3.4895767E 03	1.6460914E 04	-3.6285445E 05	-1.5033459E 05
188.90	0.	1.7330462E 03	-3.6439611E 03	1.5551180E 04	-4.0466654E 05	-1.7070274E 05
201.90	0.	1.8168029E 03	-3.44830181E 03	1.5296997E 04	-4.5125374E 05	-1.9381657E 05
214.00	0.	1.7390389E 03	-3.3564679E 03	1.2697670E 04	-4.9212345E 05	-2.1593437E 05
214.00	0.	1.7390389E 03	-3.3564679E 03	1.2697670E 04	-4.9212345E 05	-2.1593437E 05
286.00	-0.	9.1871464E 02	-1.4405216E 03	-5.4918344E 04	-4.9212345E 05	-2.5652567E 05
286.00	-0.	-1.7460826E 02	-1.4651269E 03	-5.4886248E 04	-5.8078263E 05	-2.7801347E 05
287.00	-0.	-4.4671152E 02	-1.8118689E 03	-5.4886248E 04	-5.8178994E 05	-2.7835311E 05
296.50	-0.	-7.2995704E 02	-2.1072835E 03	-5.1925966E 04	-5.9791473E 05	-2.7473417E 05
296.50	-0.	-1.7211089E 03	3.6836201E 03	1.3064822E 05	-5.9791473E 05	-4.0446916E 05
315.89	-0.	-2.0052789E 03	3.3960177E 03	1.3155474E 05	-5.2742389E 05	-3.6973823E 05
315.89	-0.	-2.0052789E 03	3.3960177E 03	1.3155474E 05	-5.2742389E 05	-3.6973823E 05
328.10	-0.	-2.0693471E 03	3.3216761E 03	1.3171074E 05	-4.8647416E 05	-3.4482151E 05
341.00	-0.	-2.1485772E 03	3.2141638E 03	1.3215146E 05	-4.4422739E 05	-3.1773351E 05
366.00	-0.	-2.5236288E 03	2.7539974E 03	1.3431687E 05	-3.6952569E 05	-2.5763345E 05
392.12	-0.	-2.6054918E 03	2.6277609E 03	1.3464740E 05	-3.0004156E 05	-1.8865386E 05
392.12	-0.	-2.6054918E 03	2.6277609E 03	1.3464740E 05	-3.0004156E 05	-1.8865386E 05
407.00	-0.	-2.6335974E 03	2.5817776E 03	1.3481958E 05	-2.6134390E 05	-1.4903029E 05
419.00	-0.	-2.6687993E 03	2.5365935E 03	1.3468844E 05	-2.3057643E 05	-1.1726656E 05
429.23	-0.	-2.6930016E 03	2.45071274E 03	1.3460574E 05	-2.0479105E 05	-8.9859819E 04
429.23	-0.	-3.0613144E 03	4.9344096E 03	1.3460574E 05	-2.0479105E 05	-8.9859819E 04
446.55	-0.	-3.0883472E 03	4.9043184E 03	1.3471836E 05	-1.1958492E 05	-3.6629332E 04
455.22	-0.	-3.0995414E 03	4.8933770E 03	1.3475660E 05	-7.7102218E 04	-9.8095331E 03
455.22	-0.	-2.9704126E 02	2.4901590E 03	-1.6801367E 02	-7.7102218E 04	-9.8095331E 03
470.80	-0.	-3.2300439E 02	2.4666114E 03	-9.1345450E 01	-3.9513797E 04	-4.9575078E 03
486.39	-0.	-3.4712024E 02	2.4453683E 03	-3.5076660E 01	-2.1482812E 02	2.5499605E 02
486.39	-0.	2.1192619E 01	1.8086120E 01	-3.5076660E 01	-2.1482812E 02	2.5499605E 02
500.00	-0.	8.2752609E 00	6.9304810E 00	-1.1044434E 01	-7.2500000E 01	8.2734375E 01
520.00	-0.	1.1444092E -04	6.1035156E -04	6.5917967E -03	1.7187500E -01	9.7656250E -02

Table 4.58 Fuselage Loading Unsymmetrical Flight Maneuvers

FUSELAGE SHEAR AND MOMENT PROGRAM - JOB NUMBER 1105 - 27 AUGUST 63

ASYMMETRIC FLIGHT CONDITION ROLL 6

OUTPUT

F.S.	FX	FY	FZ	MX	MY	MZ
-70.00	0.	0.	0.	0.	0.	0.
0.	0.	0.	0.	0.	0.	0.
20.00	0.	4.7303715E-01	-1.6525000E 01	1.0867214E 01	-4.8557744E 02	-1.5480195E 01
35.20	0.	3.7568435E 01	7.9952598E 01	7.7456554E 02	3.9752141E 02	-3.6433483E 02
47.00	0.	7.1898794E 01	-8.4107246E 00	1.4602153E 03	1.1527098E 03	-1.1998925E 03
59.00	0.	1.0167609E 02	-2.8146977E 02	2.0525884E 03	4.9361047E 02	-2.2319212E 03
71.00	0.	1.3511716E 02	-7.7315117E 02	2.4622215E 03	-5.9451369E 03	-3.6823994E 03
83.00	0.	1.7596711E 02	-1.5134400E 03	3.2444643E 03	-1.9849600E 04	-5.4465704E 03
95.00	0.	2.2242022E 02	-2.6317405E 03	4.1284435E 03	-4.3427400E 04	-7.8601555E 03
107.00	0.	2.6233872E 02	-3.5916769E 03	4.9643114E 03	-6.9472945E 04	-9.8949395E 03
119.00	0.	3.5545639E 02	-4.4080231E 03	6.3741615E 03	-1.5034940E 05	-1.5815372E 04
131.00	0.	3.5545639E 02	-4.4080231E 03	6.3741615E 03	-1.5034940E 05	-1.5815372E 04
143.00	0.	4.1812431E 02	-3.1045487E 03	7.3105411E 03	-1.9885014E 05	-2.0674892E 04
155.00	0.	4.5919224E 02	-2.8483669E 03	7.4364598E 03	-2.3535532E 05	-2.6977394E 04
167.00	0.	4.5919224E 02	-2.8483669E 03	7.4364598E 03	-2.3535532E 05	-2.6977394E 04
179.00	0.	4.6138272E 02	-3.8533843E 03	7.3197985E 03	-2.8318074E 05	-3.3066924E 04
191.00	0.	5.2147650E 02	-4.4123348E 03	8.2505341E 03	-3.4453749E 05	-4.0567184E 04
203.00	0.	5.4433086E 02	-5.0661719E 03	8.8863337E 03	-4.0265028E 05	-4.6984129E 04
215.00	0.	5.4317049E 02	-5.6020485E 03	9.2137803E 03	-4.6502272E 05	-5.3393006E 04
227.00	0.	5.6236641E 02	-5.5442237E 03	9.5373151E 03	-5.3799573E 05	-6.0595201E 04
239.00	0.	5.1597514E 02	-5.6289341E 03	9.8844919E 03	-6.0436565E 05	-6.7379230E 04
251.00	0.	3.2211691E 02	7.6530926E 02	1.2003178E 03	-6.0436565E 05	-7.8890592E 04
263.00	0.	-1.4709082E 02	-1.1761977E 03	1.2753856E 05	-6.0013516E 05	-8.1381028E 04
275.00	0.	-1.4709082E 02	-1.1761977E 03	1.2753856E 05	-6.0013516E 05	-8.1381028E 04
287.00	0.	-3.3840960E 02	-1.9768722E 03	1.2849717E 05	-6.0027601E 05	-8.1435193E 04
299.00	0.	-5.6222925E 02	5.1924377E 03	1.2930424E 05	-6.1711447E 05	-7.9357297E 04
311.00	0.	-6.4477491E 02	4.3994222E 03	6.6850429E 03	-5.2005332E 05	-1.2655746E 05
323.00	0.	-6.4477491E 02	4.3994222E 03	6.6850429E 03	-5.2005332E 05	-1.2655746E 05
335.00	0.	-6.6195461E 02	4.1818879E 03	6.9863788E 03	-4.6783316E 05	-1.0725878E 05
347.00	0.	-6.8707718E 02	3.9091091E 03	7.4411950E 03	-4.1545806E 05	-9.8598740E 04
359.00	0.	-8.0923471E 02	2.8391455E 03	9.0963466E 03	-3.3183914E 05	-7.9409468E 04
371.00	0.	-9.3467267E 02	2.5459245E 03	9.4841921E 03	-2.6244772E 05	-5.7318882E 04
383.00	0.	-9.3467267E 02	2.5459245E 03	9.4841921E 03	-2.6244772E 05	-5.7318882E 04
395.00	0.	-8.4154409E 02	2.4414171E 03	9.9207397E 03	-2.2548056E 05	-4.4657311E 04
407.00	0.	-8.5033071E 02	2.3387396E 03	1.0004732E 04	-1.9667444E 05	-3.4516295E 04
419.00	0.	-8.5645837E 02	2.2717574E 03	1.0023626E 04	-1.7311775E 05	-2.5792418E 04
431.00	0.	-9.2440205E 02	4.2321940E 03	1.0023626E 04	-1.7311775E 05	-2.5792418E 04
443.00	0.	-9.3296616E 02	4.1638050E 03	1.0098675E 04	-1.0040022E 05	-9.7164934E 03
455.00	0.	-9.3636968E 02	4.1389381E 03	1.0120589E 04	-6.4387281E 04	-1.6149246E 03
467.00	0.	-4.6345335E 01	2.1033381E 03	-8.2351440E 01	-6.4387281E 04	-1.6149246E 03
479.00	0.	-5.4284698E 01	2.0493206E 03	-4.0393555E 01	-3.2092812E 04	-8.2451317E 02
491.00	0.	-6.1593094E 01	2.0015413E 03	-1.3759766E 01	-4.8834375E 02	7.6087280E 01
503.00	0.	6.3505888E 00	4.1104675E 01	-1.3759766E 01	-4.8834375E 02	7.6087280E 01
515.00	0.	2.4568121E 00	1.5709777E 01	-3.7072754E 00	-1.6318750E 02	2.4546387E 01
527.00	0.	-3.6621094E-04	1.2207031E-03	2.9296875E-03	5.0000000E-01	8.05664406E-03

Table 4.59 Fuselage Loading Unsymmetrical Flight Maneuvers

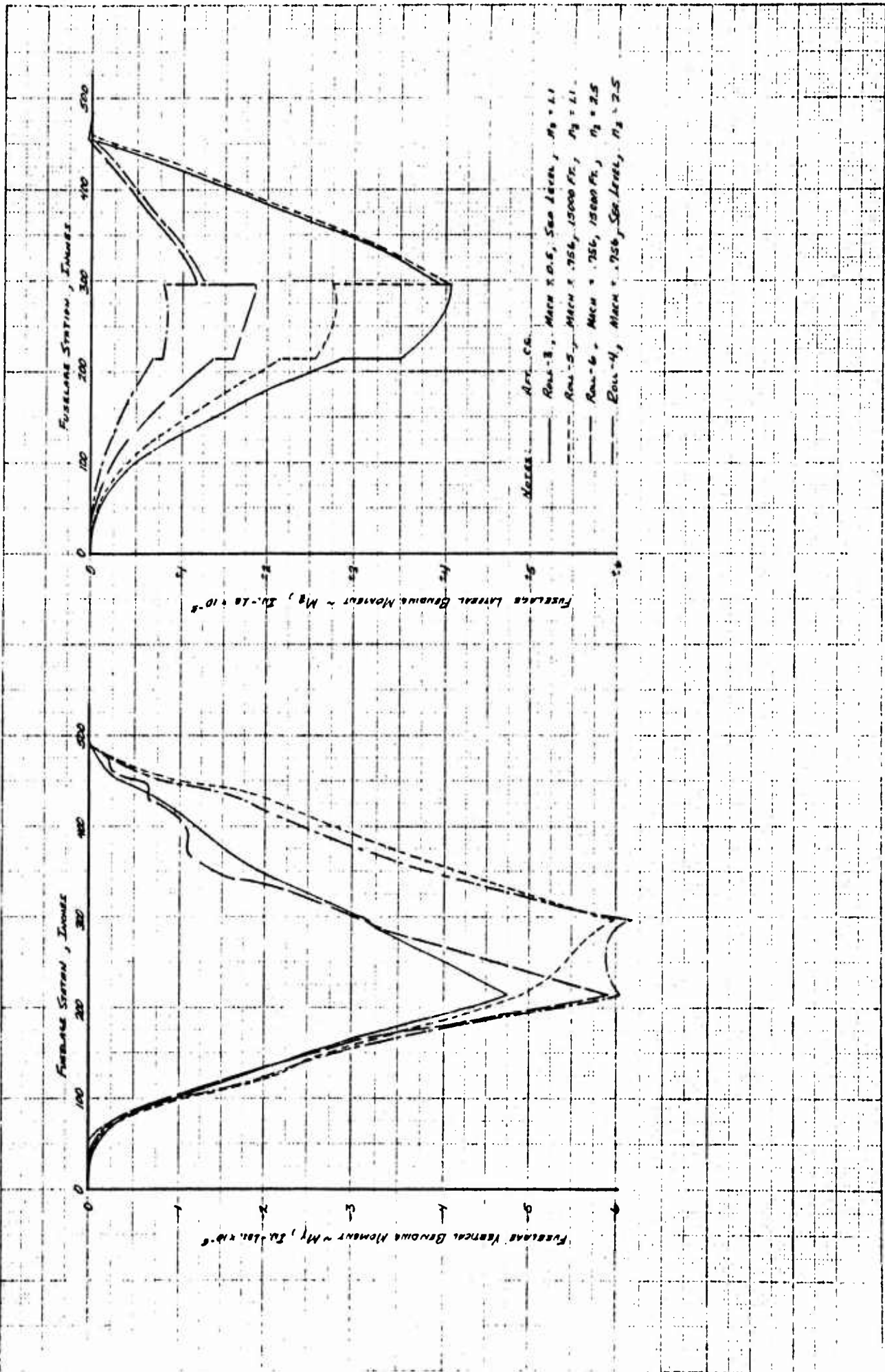

Figure 4.35 Fuselage Bending Moment Curves Rolling Pullout Maneuver

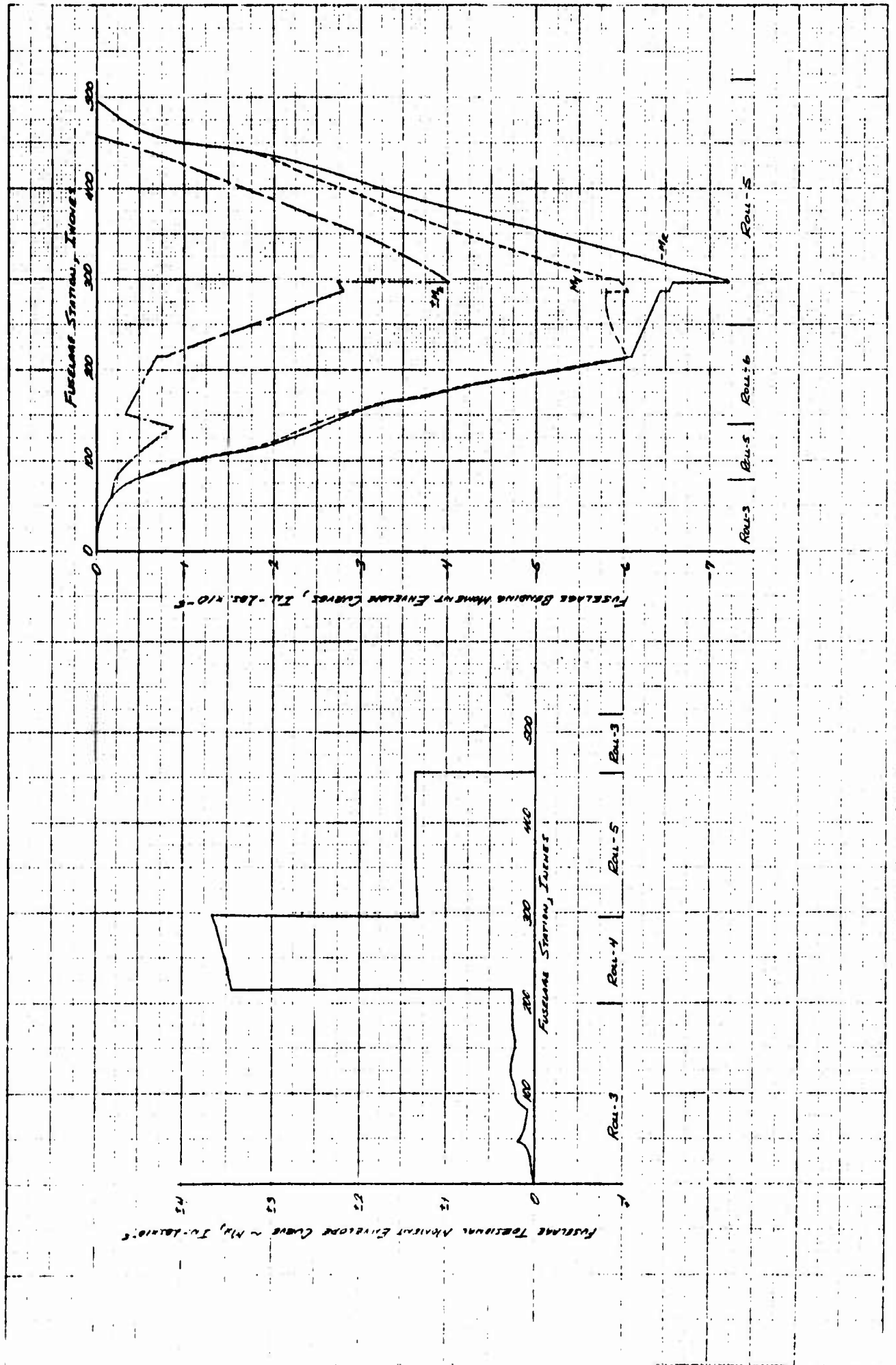

Figure 4.36 Fuselage Moment Envelope Curves Rolling Pullout Maneuver

4.5.4 Landing Conditions

A detailed study has been made of the fuselage distributed loading resulting from 20 symmetrical and unsymmetrical landing conditions. The landing-gear applied loads for the conditions resulted from the landing analysis of Reference 7. Wing lift equal to aircraft weight was assumed for all of the landing conditions and was applied at the forward and aft wing spar locations. Tabulated values of the landing gear loads and resulting aircraft load factors and angular accelerations are given in Table 4.60 for the symmetrical landing conditions and in Table 4.61 for the unsymmetrical landing conditions.

A graphical summary of the fuselage loads resulting from the landing conditions is given by Figures 4.37 through 4.39. The fuselage vertical bending moment envelope curves for the symmetrical landing conditions are shown in Figure 4.37. The conditions which produce the positive M_y envelope curve are indicated at the top of the figure and those for the negative M_y envelope are indicated at the bottom.

Fuselage torsional, lateral, and resultant bending moment envelope curves for the unsymmetrical landing conditions are presented in Figures 4.38 and 4.39. The landing conditions which produce the curves are indicated on each figure. The resultant bending moment envelope curve of Figure 4.39 was determined from the relation

$$M_R = \sqrt{M_z^2 + M_y^2}$$

The values of M_y and M_z which produce the M_R curve and also the corresponding values of M_x are also shown on Figure 4.39.

Tabulated values of the fuselage loads resulting from the nine landing conditions which result in critical loads are given in Tables 4.62 through 4.70

XV-5A SYMMETRICAL LANDING CONDITIONS

MAIN GEAR LOADS APPLIED AT TRIPPO -002 (F.S. 275.65 W.L. 390, B.L. 510)
 NOSE GEAR LOADS APPLIED TO WHEEL TIRE (F.S. 135.312, W.L. 293, B.L. 0.0)

COND No	CONDITION	Wt STA	Nose Gear Fx, LBS.	Nose Gear Fz, LBS	Main Gear (Left) Fx, LBS	Main Gear (Left) Fz, LBS	Main Gear (Right) Fx, LBS	Main Gear (Right) Fz, LBS	Nz	Ny	R/Sec
L-1	THREE-POINT SPIN-UP	240.0	4092	540	5108	7345	-7547	1.62	3.19	1.62	-5.37
L-2	TWO-POINT LEVEL SPIN-UP	240.0	0	0	5174	7114	-1097	1.56	2.99	1.56	-2.55
L-3	TWO-POINT TAIL-DOWN SPIN-UP	240.0	0	0	4432	9621	-1092	.96	3.09	.96	-7.32
L-4	THREE-POINT SPIN-UP	240.0	-3823	1540	-4780	3002	13570	-1.44	3.20	-1.44	5.72
L-5	TWO-POINT LEVEL SPIN-UP	240.0	0	0	-7113	6715	19120	-1.55	3.81	-1.55	.90
L-6	TWO-POINT TAIL-DOWN SPIN-UP	240.0	0	0	-5373	12781	21409	-1.82	3.98	-1.82	1.05
L-7	TWO-POINT LEVEL SPIN-UP	240.0	1552	6230	2257	9029	-2096	.66	3.64	.66	-2.48
L-8	THREE-POINT LEVEL SPIN-UP	240.0	0	0	2338	1213	-1254	.51	3.67	.51	-6.62
L-9	TWO-POINT TAIL-DOWN SPIN-UP	240.0	0	0	1105	12492	856	.24	3.71	.24	-5.65
L-10	THREE-POINT SPIN-UP	240.0	3604	-234	5613	7651	-10125	1.61	3.19	1.61	-5.61
L-11	TWO-POINT LEVEL SPIN-UP	240.0	0	0	5774	3174	-10007	1.26	2.99	1.26	-7.35
L-12	TWO-POINT TAIL-DOWN SPIN-UP	240.0	0	0	4432	9621	-7072	.96	3.09	.96	-6.46
L-13	THREE-POINT SPIN-UP	240.0	-5204	5174	-5461	10212	10051	-1.54	3.82	-1.54	5.80
L-14	TWO-POINT LEVEL SPIN-UP	240.0	0	0	-7113	12781	21409	-1.55	3.81	-1.55	1.94
L-15	TWO-POINT TAIL-DOWN SPIN-UP	240.0	0	0	-5373	12781	21409	-1.82	3.98	-1.82	2.78
L-16	THREE-POINT LEVEL SPIN-UP	240.0	1213	1540	2382	9550	-2092	.66	3.64	.66	-2.48
L-17	TWO-POINT TAIL-DOWN SPIN-UP	240.0	0	0	2338	1213	-1254	.51	3.67	.51	-5.61
L-18	THREE-POINT LEVEL SPIN-UP	240.0	0	0	1105	12492	856	.24	3.71	.24	-4.65
L-19	TWO-POINT TAIL-DOWN SPIN-UP	240.0	0	0	4432	9621	-7072	.96	3.09	.96	-6.46

Table 4.60 XV-5A Symmetrical Landing Conditions

XV-5A UNSYMMETRICAL LANDING CONDITIONS

MAIN GEAR LOADS ARE APPLIED AT TAPER AREA
(F.S. 275.65, W.L. 59.0, R.L. 59.0)

CONDITION NUMBER	L-10	L-20
CONDITION	TWO-POINT SIDE DRIFT	TWO-POINT SIDE DRIFT
C.G. STATION	240.0	246.0
NOSE GEAR F_x , LBS.	0	0
NOSE GEAR F_y , LBS.	0	0
NOSE GEAR F_z , LBS.	0	0
LEFT MAIN GEAR F_x , LBS.	-346	-346
LEFT MAIN GEAR F_y , LBS.	3613	3613
LEFT MAIN GEAR F_z , LBS.	6060	6060
RIGHT MAIN GEAR F_x , LBS.	-346	-346
RIGHT MAIN GEAR F_y , LBS.	4858	4858
RIGHT MAIN GEAR F_z , LBS.	6060	6060
LEFT MAIN GEAR M_x , IN.-LBS.	41382	41382
LEFT MAIN GEAR M_y , IN.-LBS.	2323	2323
LEFT MAIN GEAR M_z , IN.-LBS.	-885	-885
RIGHT MAIN GEAR M_x , IN.-LBS.	59700	59700
RIGHT MAIN GEAR M_y , IN.-LBS.	2323	2323
RIGHT MAIN GEAR M_z , IN.-LBS.	1325	1325
M_x	-1.075	-1.075
M_y	.924	.924
M_z	2.317	2.317
$\ddot{\phi}$, RAD./SEC ²	11.67	11.14
$\ddot{\theta}$, RAD./SEC ²	-2.03	-1.57
$\ddot{\psi}$, RAD./SEC ²	2.20	2.00

Table 4.61 XV-5A Unsymmetrical Landing Conditions

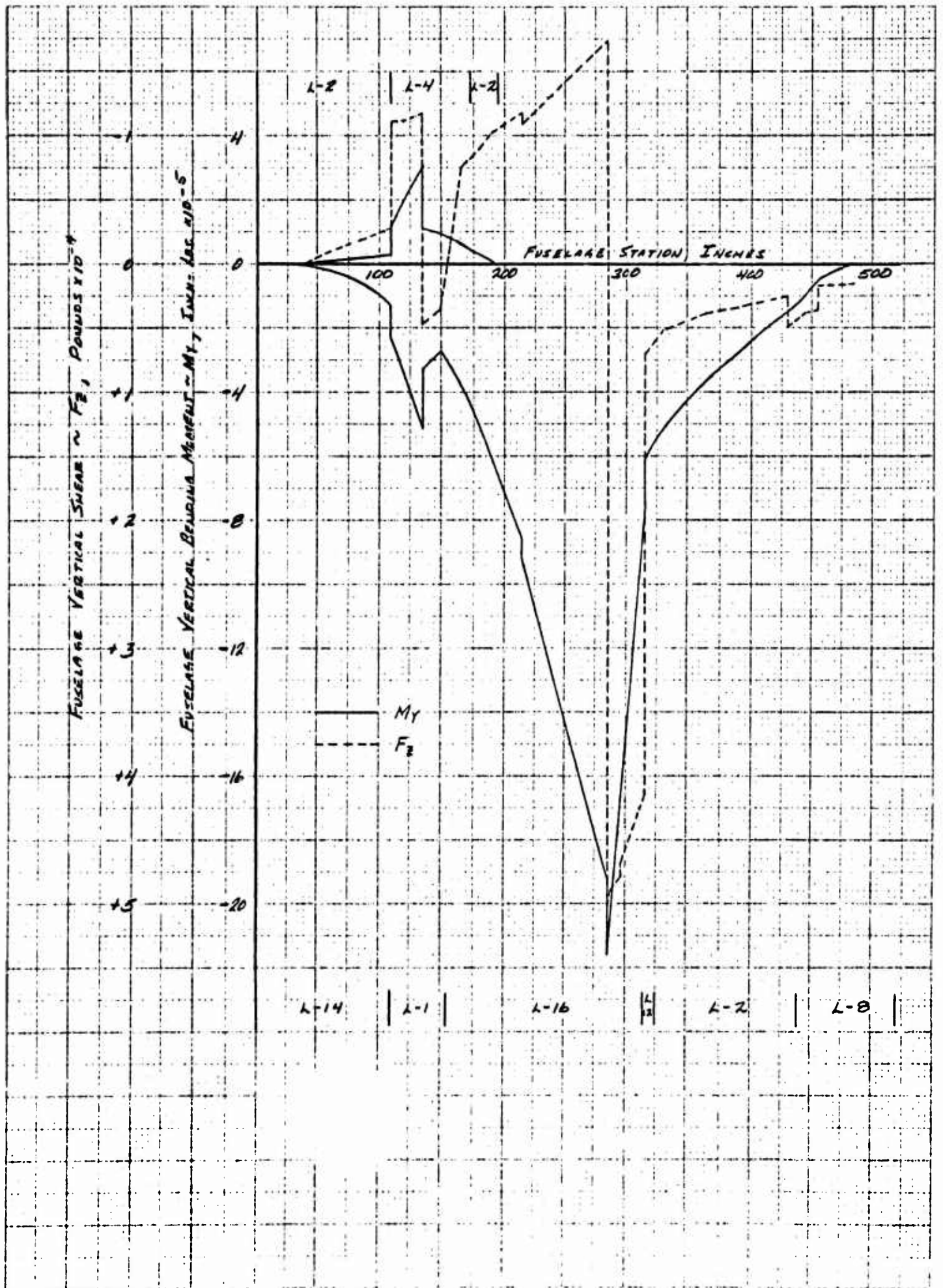

Figure 4.37 Fuselage Bending Moment Envelope Curves Symmetrical Landing Conditions 219

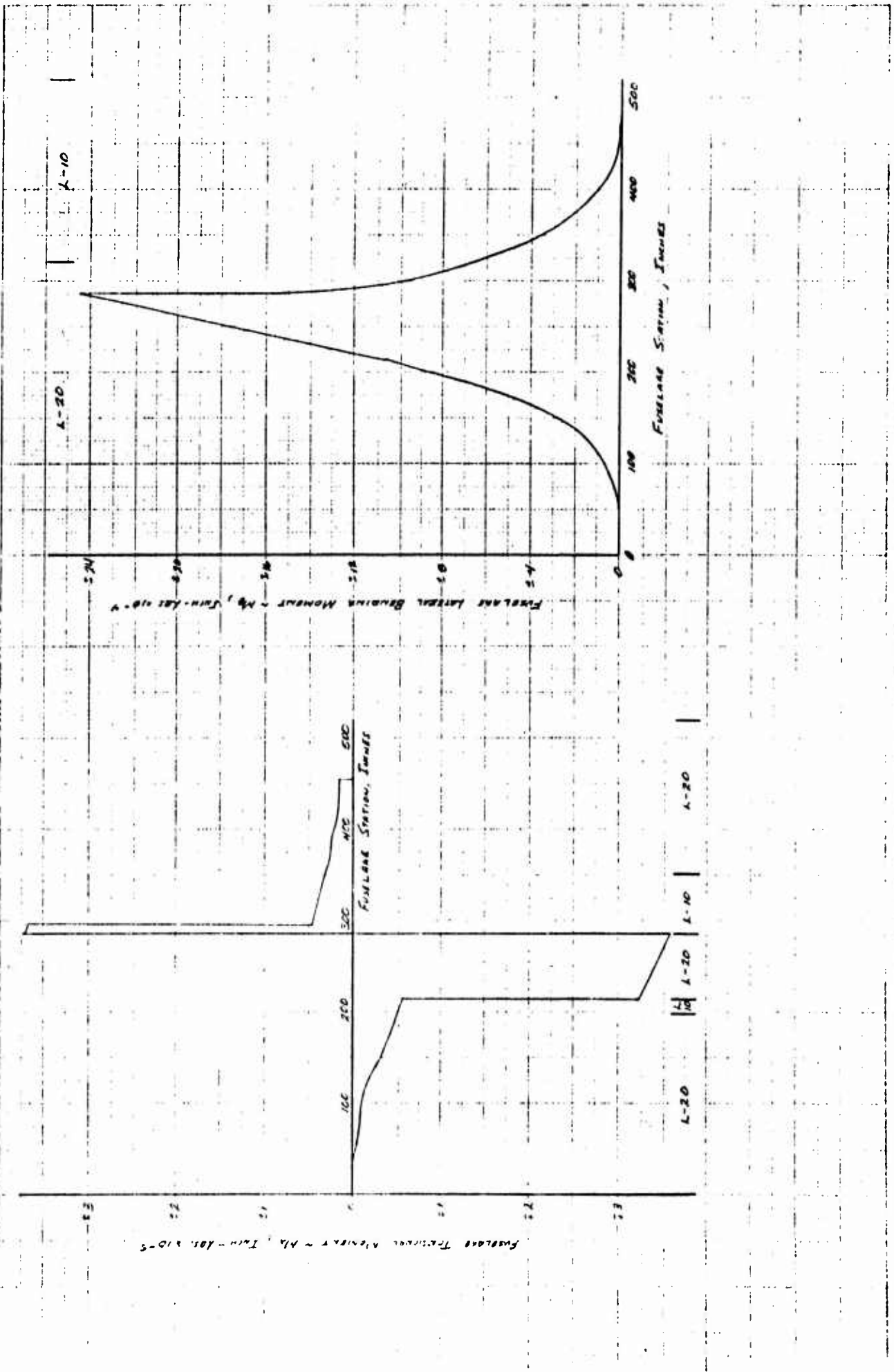

Figure 4.38 Fuselage Bending Moment Envelope Curves Unsymmetrical Landing Conditions

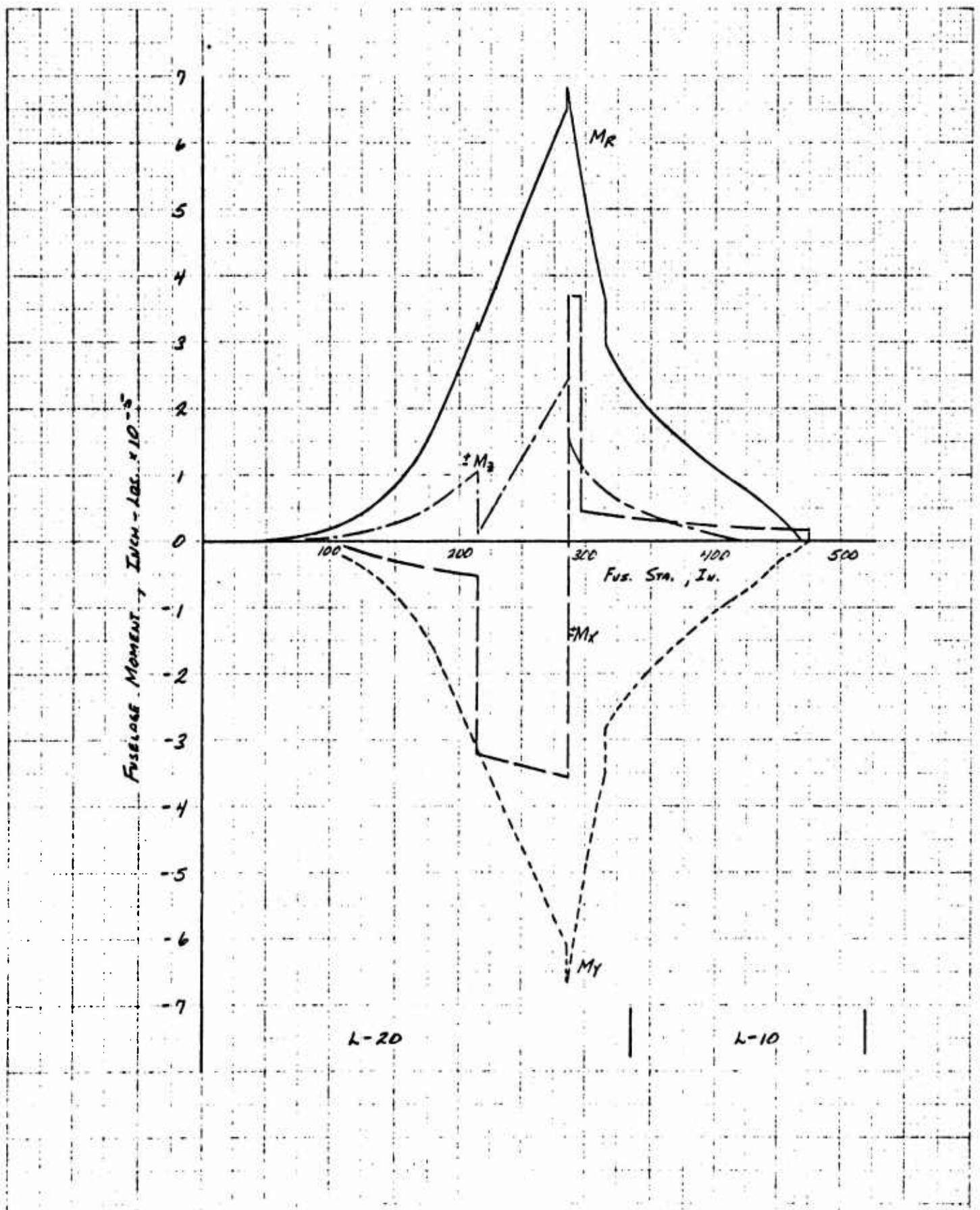

Figure 4.39 Fuselage Bending Moment Envelope Curves Unsymmetrical Landing Conditions

FUSELAGE SHEAR AND MOMENT PROGRAM - JOB NUMBER 1105 - 12/19/62

SYMMETRIC LANDING CONDITION L-1

OUTPUT

F.S.	FX	FY	FZ	MX	MY	MZ
-70.00	0.	0.	0.	0.	0.	0.
0.	-1.3512369E 01	0.	6.5072454E 00	0.	5.2601613E 02	0.
20.00	-3.032836E 01	0.	1.0062099E 01	0.	1.0319415E 03	0.
35.00	-3.817296E 01	0.	1.055439E 01	0.	1.3419795E 03	0.
47.00	-1.1175871E 02	0.	6.5432323E 00	0.	3.0165301E 03	0.
59.00	-2.8245395E 02	0.	-2.2692652E 01	0.	3.3453469E 03	0.
71.00	-5.0215472E 02	0.	-5.2325756E 01	0.	6.957550E 03	0.
82.00	-4.935327E 02	0.	-8.8509315E 01	0.	6.0216306E 03	0.
91.00	-5.6414944E 02	0.	-1.1870044E 02	0.	6.5914417E 03	0.
110.00	-8.223686E 02	0.	-2.093338E 02	0.	5.5065756E 03	0.
110.00	0.333933E 03	0.	-1.1122833E 01	0.	-2.253037E 03	0.
122.00	7.735549E 03	0.	-1.327510E 01	0.	-3.6224451E 03	0.
136.00	7.835659E 03	0.	-1.1770651E 01	0.	-3.171711E 03	0.
156.00	2.877733E 03	0.	4.8552403E 03	0.	-5.316095E 03	0.
150.00	1.977734E 03	0.	3.540226E 03	0.	-2.7429230E 03	0.
177.00	6.337164E 04	0.	2.333154E 03	0.	-1.7466067E 03	0.
188.00	-3.144377E 04	0.	1.507010E 03	0.	-1.472328E 03	0.
203.00	-3.195639E 03	0.	3.31363E 01	0.	-1.208383E 03	0.
214.00	-3.154616E 03	0.	-2.209360E 01	0.	-1.2751209E 03	0.
214.00	-3.154616E 03	0.	3.179602E 03	0.	-1.410464E 04	0.
226.00	-3.154616E 03	0.	-3.89403E 03	0.	-9.360826E 04	0.
236.00	-3.154616E 03	0.	-5.11587E 03	0.	3.531785E 04	0.
257.00	-3.154616E 03	0.	-6.369703E 03	0.	-6.809126E 04	0.
296.00	-3.154616E 03	0.	-9.14759E 03	0.	-1.328834E 03	0.
315.00	-1.010634E 04	0.	-1.102326E 04	0.	-1.328834E 03	0.
315.00	1.010634E 04	0.	3.154869E 03	0.	3.207032E 03	0.
329.00	1.010634E 04	0.	4.576931E 03	0.	3.149116E 03	0.
341.00	1.010634E 04	0.	4.27868E 03	0.	-5.353271E 03	0.
366.00	6.337164E 04	0.	3.365466E 03	0.	3.9660567E 03	0.
392.00	-1.554037E 03	0.	2.65417E 03	0.	-2.140367E 03	0.
392.00	1.554037E 03	0.	2.65417E 03	0.	2.140367E 03	0.
419.00	3.237029E 03	0.	2.615562E 03	0.	-1.723230E 03	0.
429.00	2.741671E 03	0.	2.214533E 03	0.	-1.4161700E 03	0.
429.00	2.741671E 03	0.	3.199021E 03	0.	-1.176244E 03	0.
446.00	2.314654E 03	0.	2.399915E 03	0.	-6.453300E 03	0.
459.00	3.333333E 03	0.	2.29574E 03	0.	3.009024E 03	0.
459.00	3.333333E 03	0.	1.379713E 03	0.	-3.599034E 04	0.
470.00	3.174013E 03	0.	1.37705E 03	0.	-1.0711912E 04	0.
488.00	3.65168E 03	0.	1.264467E 03	0.	-1.440300E 03	0.
488.00	3.65168E 03	0.	1.193714E 03	0.	-1.440300E 03	0.
500.00	1.1021493E 03	0.	4.54243E 03	0.	-3.9911730E 03	0.
520.00	1.1021493E 03	0.	-2.265549E 03	0.	-3.9911730E 03	0.

Table 4.62 Fuselage Loading Landing Conditions

FUSELAGE SHEAR AND MOMENT PROGRAM - JOB NUMBER 1105 - 12/19/62

SYMMETRIC LANDING CONDITION L-2

OUTPUT

F.S.	FX	FY	FZ	MX	MY	MZ
-70.00	0.0	0.0	0.0	0.0	0.0	0.0
0.0	-1.145809E 01	0.0	1.8261520E 01	0.0	8.5145692E 02	0.0
20.00	-2.647111E 01	0.0	3.5899840E 01	0.0	1.7092305E 03	0.0
30.00	-3.815919E 01	0.0	4.225694E 01	0.0	2.4473732E 03	0.0
47.00	-9.615801E 01	0.0	9.0181751E 01	0.0	4.7020762E 03	0.0
59.00	-2.232187E 01	0.0	1.6735477E 02	0.0	8.0830255E 03	0.0
71.00	-5.139930E 02	0.0	2.497999E 02	0.0	1.2629111E 04	0.0
82.60	-4.235242E 02	0.0	2.5059950E 02	0.0	1.7026780E 04	0.0
91.00	-4.523275E 02	0.0	2.6079937E 02	0.0	2.0562759E 04	0.0
110.00	-7.237856E 02	0.0	2.5274320E 02	0.0	2.9542305E 04	0.0
110.00	-7.427656E 02	0.0	2.2474320E 02	0.0	2.9542305E 04	0.0
122.50	-9.027147E 02	0.0	2.197658E 02	0.0	3.5403424E 04	0.0
135.00	-1.044559E 03	0.0	-1.198586E 01	0.0	4.2060416E 04	0.0
136.50	-1.043459E 03	0.0	-1.198859E 01	0.0	4.2060416E 04	0.0
150.00	-1.967795E 03	0.0	-7.038157E 02	0.0	4.2286650E 04	0.0
155.00	-2.457711E 03	0.0	-7.038157E 02	0.0	3.7756304E 04	0.0
177.20	-2.752219E 03	0.0	-1.2690192E 03	0.0	3.0986350E 04	0.0
196.70	-3.235722E 03	0.0	-2.0485790E 03	0.0	1.5633729E 04	0.0
211.00	-3.630955E 03	0.0	-2.351473E 03	0.0	-1.3386611E 04	0.0
214.00	-3.935535E 03	0.0	-3.358525E 03	0.0	-4.8541066E 04	0.0
214.00	-7.735527E 03	0.0	-2.527143E 02	0.0	-3.7033356E 03	0.0
236.00	-9.317044E 03	0.0	-5.0253112E 03	0.0	-1.9723905E 05	0.0
335.00	-9.573543E 03	0.0	-3.0210431E 03	0.0	-1.9740973E 05	0.0
297.00	-9.662415E 03	0.0	-4.2053652E 03	0.0	-1.9843420E 05	0.0
298.50	-1.035626E 04	0.0	-5.7099321E 03	0.0	-2.3632292E 05	0.0
298.50	-1.035626E 04	0.0	-5.7099321E 03	0.0	-2.3632292E 05	0.0
315.89	-9.440324E 03	0.0	3.935702E 04	0.0	-4.1302205E 05	0.0
321.00	7.777308E 01	0.0	5.232822E 03	0.0	-6.0922741E 05	0.0
344.00	5.849099E 02	0.0	4.913107E 03	0.0	-5.5977529E 05	0.0
366.00	5.147742E 02	0.0	3.611517E 03	0.0	-4.7181417E 05	0.0
372.50	2.399089E 02	0.0	3.323374E 03	0.0	-3.6044598E 05	0.0
392.12	2.239099E 02	0.0	3.223374E 03	0.0	-2.6222266E 05	0.0
407.00	1.635076E 02	0.0	3.058562E 03	0.0	-2.6528236E 05	0.0
415.00	1.393475E 02	0.0	2.730599E 03	0.0	-2.1737073E 05	0.0
420.25	5.735500E 01	0.0	2.604547E 03	0.0	-1.506757E 05	0.0
420.25	5.735500E 01	0.0	2.604547E 03	0.0	-1.5271997E 05	0.0
446.55	3.246669E 01	0.0	3.704325E 03	0.0	-1.5231567E 05	0.0
453.22	2.274366E 01	0.0	3.632664E 03	0.0	-5.5630175E 04	0.0
473.24	7.023081E 01	0.0	1.923696E 05	0.0	-5.3410718E 04	0.0
477.50	4.433950E 01	0.0	1.500679E 05	0.0	-2.6439625E 04	0.0
486.39	2.345571E 01	0.0	1.532826E 05	0.0	-1.7120997E 05	0.0
486.39	2.345571E 01	0.0	1.532826E 05	0.0	-1.7120997E 05	0.0
510.00	7.324592E 00	0.0	5.525678E 04	0.0	-5.557157E 04	0.0
510.00	7.324592E 00	0.0	-5.525678E 04	0.0	-1.2500000E 00	0.0

Table 4.63 Fuselage Loading Landing Conditions

FUSELAGE SHEAR AND MOMENT PROGRAM - JOB NUMBER 1105 - 12/19/62

SYMMETRIC LANDING CONDITION L-4

OUTPUT

F.S. C.	FX	FY	FZ	MX	MY	MZ
-70.00	0.	0.	-0.	0.	0.	0.
1.1858965E 01	0.	0.	-5.41539916E 01	0.	-1.8213834E 03	0.
2.7616803E 01	0.	0.	-1.1705587E 02	0.	-3.6924828E 03	0.
3.4641177E 01	0.	0.	-1.4521203E 02	0.	-6.0634590E 03	0.
4.0811250E 02	0.	0.	-4.0198733E 02	0.	-1.0767265E 04	0.
2.3854927E 02	0.	0.	-9.44526001E 02	0.	-1.8972675E 04	0.
3.45624307E 02	0.	0.	-1.33981589E 03	0.	-3.6691328E 04	0.
4.4852677E 02	0.	0.	-1.7335507E 03	0.	-5.6569882E 04	0.
5.1250173E 02	0.	0.	-2.3555200E 03	0.	-7.3148525E 04	0.
7.4742732E 02	0.	0.	-3.2561603E 03	0.	-1.02151429E 05	0.
8.3367884E 03	0.	0.	7.3581802E 03	0.	1.1532684E 05	0.
8.145629E 03	0.	0.	5.0117831E 03	0.	2.1039845E 05	0.
7.6409825E 03	0.	0.	1.02361443E 03	0.	3.0944732E 05	0.
2.4429209E 03	0.	0.	-1.33312671E 03	0.	1.0555332E 05	0.
1.6978839E 03	0.	0.	-2.3590037E 03	0.	9.5805112E 04	0.
1.3000770E 03	0.	0.	-4.1097878E 03	0.	6.4636576E 04	0.
7.8554023E 02	0.	0.	-6.1016983E 03	0.	2.0985961E 04	0.
1.3213378E 02	0.	0.	-7.1512253E 03	0.	-4.2658937E 04	0.
2.2712719E 02	0.	0.	-5.7573053E 03	0.	-1.3221194E 05	0.
6.5320211E 02	0.	0.	-7.8236959E 03	0.	-2.2403953E 05	0.
4.7655713E 03	0.	0.	-1.3746672E 04	0.	-2.7234778E 05	0.
6.3550759E 03	0.	0.	3.1263477E 04	0.	-1.0627204E 06	0.
1.3515006E 04	0.	0.	3.8330752E 04	0.	-1.2097652E 06	0.
1.3934298E 04	0.	0.	2.3294786E 04	0.	-1.1767270E 06	0.
1.644628E 04	0.	0.	2.9127635E 04	0.	-5.8749532E 03	0.
1.644628E 04	0.	0.	2.7054943E 04	0.	-3.749352E 03	0.
1.1751372E 03	0.	0.	1.62608426E 03	0.	-3.5084873E 03	0.
1.0080349E 03	0.	0.	9.3255104E 02	0.	-4.1283353E 04	0.
8.7734340E 02	0.	0.	7.5575244E 02	0.	-2.3572653E 04	0.
5.3526015E 02	0.	0.	3.3906123E 01	0.	-1.9815750E 04	0.
4.1020776E 02	0.	0.	2.334663E 01	0.	-1.1634373E 04	0.
1.020776E 02	0.	0.	2.004566E 02	0.	-6.9571243E 03	0.
3.4478973E 02	0.	0.	1.3957617E 02	0.	-5.1638750E 03	0.
2.7721130E 02	0.	0.	5.2450478E 01	0.	-4.6915625E 03	0.
2.3414246E 02	0.	0.	6.3557226E 01	0.	-4.4412500E 03	0.
2.3414246E 02	0.	0.	1.147059E 02	0.	-1.44412500E 03	0.
1.3954196E 02	0.	0.	9.105002E 01	0.	-2.6228750E 03	0.
1.8125133E 02	0.	0.	8.4460445E 01	0.	-1.8440000E 03	0.
5.2445123E 01	0.	0.	5.3563723E 01	0.	-1.6440000E 03	0.
5.1778076E 01	0.	0.	5.3562205E 01	0.	-6.4745745E 02	0.
2.3918823E 01	0.	0.	5.3585740E 01	0.	3.2437500E 01	0.
2.3918823E 01	0.	0.	-4.8458045E 01	0.	3.2437500E 01	0.
2.3918823E 01	0.	0.	-1.2655713E 00	0.	1.7437500E 01	0.
2.3918823E 01	0.	0.	1.1088244E 03	0.	6.7500000E 01	0.

Table 4.64 Fuselage Loading Landing Conditions

SY METRIC LANDING CONDITION L-2

OUTPUT

F.S.	FX	FY	FZ	MX	MY	MZ
-70.00	-0.	0.	6.2719053E 00	0.	0.	0.
0.	-5.950930E 00	0.	6.5549942E 00	0.	3.6221425E 02	0.
30.00	-1.524557E 01	0.	3.9158951E 00	0.	6.6836145E 02	0.
55.20	-1.671618E 01	0.	-6.4634544E 01	0.	9.7444395E 02	0.
47.00	4.030541E 01	0.	-4.4554755E 01	0.	1.7528170E 03	0.
59.00	1.333763E 02	0.	-9.7468044E 01	0.	2.7789157E 03	0.
71.00	-1.625672E 02	0.	-1.3504397E 02	0.	2.9009124E 03	0.
82.60	-2.045375E 02	0.	-1.758532E 02	0.	2.5106947E 03	0.
110.00	3.334801E 02	0.	-5.6195665E 01	0.	1.9745285E 03	0.
11.00	3.334801E 02	0.	-3.519368E 02	0.	-6.481830E 03	0.
12.00	3.334801E 02	0.	-5.673347E 02	0.	-4.837321E 03	0.
13.00	6.220066E 02	0.	-1.161039E 03	0.	-1.4269342E 04	0.
14.00	6.220066E 02	0.	-1.161039E 03	0.	-1.4269342E 04	0.
15.00	6.220066E 02	0.	3.121943E 03	0.	3.379437E 04	0.
16.00	6.220066E 02	0.	-1.002659E 03	0.	-6.712038E 04	0.
18.20	-1.002659E 03	0.	-3.924156E 03	0.	-1.0089764E 05	0.
17.00	-1.002659E 03	0.	-7.700321E 03	0.	-1.4620714E 05	0.
19.00	-1.002659E 03	0.	-5.423593E 03	0.	-2.115009E 05	0.
21.00	-1.002659E 03	0.	-6.493311E 03	0.	-2.90173E 05	0.
24.00	-1.002659E 03	0.	3.823920E 03	0.	-2.590207E 05	0.
25.00	-1.002659E 03	0.	-1.022758E 04	0.	-7.616572E 05	0.
26.00	4.030541E 01	0.	1.353656E 04	0.	-6.546152E 05	0.
27.00	4.030541E 01	0.	1.244925E 04	0.	3.561693E 05	0.
28.00	1.991721E 02	0.	1.376253E 04	0.	-7.1707864E 05	0.
29.00	1.991721E 02	0.	7.918341E 03	0.	3.665628E 05	0.
31.00	1.991721E 02	0.	5.303202E 03	0.	3.526915E 05	0.
33.00	1.991721E 02	0.	5.328626E 03	0.	5.245926E 05	0.
35.00	1.991721E 02	0.	5.265727E 03	0.	-4.577633E 05	0.
34.00	1.737991E 02	0.	4.553553E 03	0.	3.511526E 05	0.
36.00	1.002659E 03	0.	3.703249E 03	0.	2.395142E 05	0.
37.00	1.002659E 03	0.	3.417455E 03	0.	3.395142E 05	0.
38.00	1.002659E 03	0.	2.950326E 03	0.	3.135662E 05	0.
40.00	1.002659E 03	0.	2.676047E 03	0.	-1.7501367E 05	0.
41.00	1.002659E 03	0.	2.495769E 03	0.	-1.504387E 05	0.
43.00	1.002659E 03	0.	3.006131E 03	0.	-1.523487E 05	0.
44.00	1.002659E 03	0.	3.716231E 03	0.	3.950674E 05	0.
45.00	1.002659E 03	0.	3.637503E 03	0.	5.495000E 05	0.
46.00	1.002659E 03	0.	1.652001E 03	0.	6.430000E 05	0.
47.00	1.002659E 03	0.	1.593205E 03	0.	-6.6924187E 05	0.
48.00	1.002659E 03	0.	1.532316E 03	0.	-1.625026E 05	0.
49.00	1.002659E 03	0.	1.332316E 03	0.	-1.625026E 05	0.
50.00	1.002659E 03	0.	5.2907651E 03	0.	-1.451850E 05	0.
51.00	1.002659E 03	0.	-3.4173067E 03	0.	-1.1000000E 05	0.

Table 4.65 Fuselage Loading Landing Conditions

SYMMETRIC LANDING CONDITION L-12

OUTPUT

F+S	FX	FY	FZ	MX	MY	MZ
-70.00	-0.	0.	0.	0.	0.	0.
0.	-1.1251447E 01	0.	1.9134230E 01	0.	7.4424772E 02	0.
40.00	-2.604898E 01	0.	2.9176205E 01	0.	1.4779904E 03	0.
35.20	-3.2555515E 01	0.	3.4098320E 01	0.	2.114050E 03	0.
47.00	-9.4791241E 01	0.	9.9744225E 01	0.	4.1500712E 03	0.
59.00	-2.2195820E 04	0.	1.2260423E 01	0.	7.1814450E 03	0.
71.00	-3.3470351E 00	0.	1.6099426E 01	0.	1.0992322E 04	0.
82.00	-4.1637642E 02	0.	1.7386364E 02	0.	1.4821470E 04	0.
91.00	-4.7714039E 01	0.	1.7563410E 01	0.	1.7329562E 04	0.
110.00	-7.1719122E 02	0.	1.3766137E 02	0.	2.4931653E 04	0.
118.00	-7.1719122E 02	0.	1.3766137E 02	0.	2.4931653E 04	0.
122.00	-3.9342849E 01	0.	7.3091847E 01	0.	2.4931653E 04	0.
136.00	-3.9416017E 00	0.	-1.9530355E 01	0.	3.2370149E 04	0.
138.00	-1.3416317E 03	0.	-1.3550455E 02	0.	3.2670149E 04	0.
150.00	-1.9652413E 03	0.	-5.6512101E 02	0.	2.992037E 04	0.
152.20	-2.2622823E 03	0.	-9.3022287E 02	0.	2.1746653E 04	0.
177.00	-2.6823257E 03	0.	-1.1790742E 03	0.	1.2179543E 04	0.
188.00	-3.1339429E 03	0.	-1.3251159E 03	0.	-4.779272E 03	0.
217.00	-3.3951321E 03	0.	-1.3500471E 03	0.	-5.316173E 03	0.
244.00	-5.5420830E 03	0.	-3.904018E 03	0.	-6.937793E 03	0.
247.00	-7.3128371E 03	0.	-8.670233E 03	0.	-2.093790E 04	0.
288.00	-6.9579101E 03	0.	-9.040153E 03	0.	-2.240053E 03	0.
286.00	-8.9476700E 03	0.	-1.2255672E 03	0.	-2.273125E 03	0.
287.00	-9.3297336E 03	0.	-4.260020E 03	0.	-2.6441216E 03	0.
286.00	-9.7810226E 03	0.	-7.295519E 03	0.	-2.632090E 03	0.
315.00	-1.0298696E 04	0.	-9.3656734E 03	0.	-4.189702E 03	0.
315.00	-1.2306643E 03	0.	6.977958E 03	0.	-6.181155E 03	0.
328.00	1.0637972E 03	0.	6.9872917E 03	0.	-3.267878E 03	0.
347.00	9.3606943E 02	0.	3.9240720E 03	0.	-4.5042037E 03	0.
350.00	4.1741095E 02	0.	3.7264231E 03	0.	-3.2950254E 03	0.
392.12	2.5721600E 02	0.	3.071037E 03	0.	-2.4166712E 03	0.
392.12	2.5721600E 02	0.	3.071037E 03	0.	-2.4166712E 03	0.
417.00	2.0838013E 02	0.	2.324773E 03	0.	-1.937698E 03	0.
419.00	1.4630310E 01	0.	2.3693753E 03	0.	-1.640887E 03	0.
429.23	1.0712030E 01	0.	2.5978397E 03	0.	-1.3823544E 03	0.
429.23	1.0712030E 01	0.	3.5093470E 03	0.	-1.3823544E 03	0.
448.00	7.3932038E 01	0.	3.4266711E 03	0.	-7.724007E 04	0.
455.22	5.1732700E 01	0.	3.557580E 03	0.	-4.7791405E 04	0.
455.22	7.1421673E 01	0.	1.9370413E 03	0.	-4.7791405E 04	0.
470.00	4.4244360E 01	0.	1.4843683E 03	0.	-2.3649437E 03	0.
488.00	2.0748340E 01	0.	1.3405029E 03	0.	-1.572937E 03	0.
486.00	2.0748340E 01	0.	1.287500E 02	0.	-1.572937E 03	0.
500.00	8.0151978E 00	0.	3.0741943E 01	0.	-5.104667E 02	0.
520.00	1.4646437E 03	0.	-3.1738351E 03	0.	-1.0312500E 00	0.

Table 4.66 Fuselage Loading Landing Conditions

FUSELAGE SHEAR AND MOMENT PROGRAM - JOB NUMBER 1105 - 12/19/62

SYMMETRIC LANDING CONDITION L-14

OUTPUT

F.S.	FX	FY	FZ	VX	VY	VZ
-70.00	0.	0.	-0.	0.	-0.	0.
0.	1.2472007E 01	0.	-5.2574803E 01	0.	-1.8661822E 03	0.
20.00	2.9363689E 01	0.	-1.1944930E 02	0.	-3.9830445E 03	0.
35.20	3.6459751E 01	0.	-1.4818027E 02	0.	-6.2087161E 03	0.
47.00	1.5113033E 02	0.	-4.1040465E 02	0.	-1.1070533E 04	0.
55.00	2.8144255E 02	0.	-8.6534750E 02	0.	-1.9486665E 04	0.
71.00	3.7514255E 02	0.	-1.4222361E 03	0.	-3.7642560E 04	0.
82.60	4.7276943E 02	0.	-1.7707409E 03	0.	-5.778794E 04	0.
91.00	5.6542042E 02	0.	-1.9576200E 03	0.	-7.4966375E 04	0.
110.00	8.1634023E 02	0.	-2.9436662E 03	0.	-1.2448421E 05	0.
122.50	6.7350625E 03	0.	6.4203973E 01	0.	7.4055471E 04	0.
123.50	6.3110915E 03	0.	3.1506889E 01	0.	1.4573627E 05	0.
136.50	5.9731827E 03	0.	3.7497347E 01	0.	2.1041706E 05	0.
150.00	1.6317797E 03	0.	-4.625183E 01	0.	4.1993335E 04	0.
150.00	6.335445E 02	0.	-2.5831335E 03	0.	1.5553707E 04	0.
163.25	5.4318955E 02	0.	-5.8267518E 03	0.	-3.4888336E 04	0.
177.20	5.3956577E 01	0.	-1.1070721E 03	0.	-9.1439914E 04	0.
188.90	4.9357206E 02	0.	-6.768015E 01	0.	-1.631277E 05	0.
201.91	7.3600802E 02	0.	-3.2243724E 03	0.	-2.5675573E 05	0.
214.00	1.0367215E 03	0.	-8.5662738E 03	0.	-3.4807044E 05	0.
214.00	5.3795184E 03	0.	-1.9011744E 03	0.	-3.927201E 05	0.
286.00	7.6246625E 03	0.	-1.4455933E 04	0.	-1.2355675E 06	0.
287.00	1.7381964E 04	0.	3.4731455E 04	0.	-1.3963419E 06	0.
287.00	1.750921E 04	0.	3.3690395E 04	0.	-1.3591436E 06	0.
296.50	1.8116844E 04	0.	3.2581459E 04	0.	-1.0374343E 06	0.
296.50	1.8116844E 04	0.	3.1994677E 04	0.	-1.0374343E 06	0.
315.69	1.8739778E 04	0.	3.0875448E 04	0.	-4.2632387E 05	0.
315.89	-1.6395439E 03	0.	2.0086191E 03	0.	-7.9875406E 04	0.
328.10	-1.4591985E 03	0.	1.7113786E 03	0.	-5.9018489E 04	0.
341.00	-1.2762435E 03	0.	1.4144600E 03	0.	-3.9319062E 04	0.
366.00	-6.2679516E 02	0.	4.4972656E 02	0.	-1.7178437E 04	0.
352.12	-4.4523156E 02	0.	2.2687866E 02	0.	-9.7765000E 03	0.
407.00	-3.765932E 02	0.	1.6297158E 02	0.	-7.6470625E 03	0.
419.00	-3.6475146E 02	0.	1.0984375E 02	0.	-6.9575875E 03	0.
429.23	-2.592625E 02	0.	7.9149598E 01	0.	-6.5345625E 03	0.
429.23	-2.592625E 02	0.	1.6047670E 02	0.	-6.5345625E 03	0.
446.55	-2.1813660E 01	0.	1.3501025E 02	0.	-2.7740000E 03	0.
455.22	-2.0309326E 02	0.	1.276221E 02	0.	-2.7740000E 03	0.
455.22	-6.759736E 01	0.	1.0023015E 02	0.	-2.7740000E 03	0.
470.80	-5.4935349E 01	0.	8.7916015E 01	0.	-1.3030625E 03	0.
486.39	-2.370649E 01	0.	8.1773193E 01	0.	2.0937500E 01	0.
486.39	-2.5270642E 01	0.	4.4415092E 01	0.	2.0937500E 01	0.
500.00	-9.7574465E 00	0.	-9.3041992E 01	0.	1.3625000E 01	0.
520.00	-1.2207031E 03	0.	1.2207031E 03	0.	8.7500000E 01	0.

Table 4.67 Fuselage Loading Landing Conditions

FUSELAGE SHEAR AND MOMENT PROGRAM - JOB NUYSER 1105 - 12/19/62

SYMMETRIC LANDING CONDITION L-16

OUTPUT

F.S.	FX	FY	FZ	MX	MY	MZ
-70.00	0.	0.	-0.	0.	-0.	0.
0.	1.3145747E 01	0.	-3.8090792E 01	0.	-1.4357764E 03	0.
20.00	3.0922673E 01	0.	-8.7807922E 01	0.	-3.0955091E 03	0.
35.00	3.8846848E 01	0.	-1.0946170E 02	0.	-4.7776493E 03	0.
47.00	1.1346034E 02	0.	-3.0226544E 02	0.	-6.8001837E 03	0.
59.00	2.7345516E 02	0.	-7.3770930E 02	0.	-1.5745032E 04	0.
71.00	4.0909409E 02	0.	-1.5965461E 03	0.	-3.0194360E 04	0.
82.00	5.1416373E 02	0.	-1.3657932E 03	0.	-4.6180047E 04	0.
91.00	5.8627031E 02	0.	-1.5459045E 03	0.	-5.9820342E 04	0.
110.00	8.9107727E 02	0.	-2.3120049E 03	0.	-9.9292197E 04	0.
118.00	8.9107727E 02	0.	-2.3120049E 03	0.	-9.9292197E 04	0.
122.00	1.1185395E 03	0.	-2.8757866E 03	0.	-1.3450006E 05	0.
136.50	1.7203197E 03	0.	-4.3817335E 03	0.	-1.8577000E 05	0.
136.50	1.7203197E 03	0.	-4.3817335E 03	0.	-1.8577000E 05	0.
150.00	2.6103291E 03	0.	-6.5906623E 03	0.	-2.6709625E 05	0.
165.00	3.0051096E 03	0.	-7.4871429E 03	0.	-3.7748001E 05	0.
177.00	3.5677933E 03	0.	-8.7811660E 03	0.	-4.7923120E 05	0.
188.00	4.2006600E 03	0.	-1.0256195E 04	0.	-5.9206232E 05	0.
201.00	4.5058780E 03	0.	-1.0941010E 04	0.	-7.2972544E 05	0.
214.00	4.9005010E 03	0.	-1.1906511E 04	0.	-8.903875E 05	0.
214.00	9.7207096E 03	0.	-1.0879697E 04	0.	-9.3579478E 05	0.
266.00	1.2674801E 04	0.	-1.0879697E 04	0.	-1.09371009E 06	0.
286.00	2.5733482E 04	0.	-1.7447017E 04	0.	-2.1591285E 06	0.
287.00	2.6317663E 04	0.	5.0333343E 04	0.	-2.1048735E 06	0.
293.00	2.6500044E 04	0.	4.9197105E 04	0.	-2.1048735E 06	0.
293.00	2.6500044E 04	0.	4.9197105E 04	0.	-2.1048735E 06	0.
315.00	2.7703706E 04	0.	4.9544306E 04	0.	-1.6351037E 06	0.
315.00	2.7703706E 04	0.	4.9544306E 04	0.	-1.6351037E 06	0.
315.00	-2.1003746E 03	0.	3.3258208E 03	0.	-7.3682321E 03	0.
328.00	-1.8946185E 03	0.	2.8678628E 03	0.	-2.3014023E 03	0.
341.00	-1.6770572E 03	0.	2.5921718E 03	0.	-1.3545294E 03	0.
366.00	-8.9409082E 02	0.	1.2804545E 03	0.	-1.5752282E 05	0.
392.00	-6.7668384E 02	0.	9.4110399E 02	0.	-1.0000000E 01	0.
392.00	-6.7668384E 02	0.	9.4110399E 02	0.	-1.0000000E 01	0.
407.00	-5.9820154E 02	0.	8.2898609E 02	0.	-8.00714124E 04	0.
415.00	-5.1948824E 02	0.	7.2356665E 02	0.	-6.0352750E 04	0.
429.00	-4.6663281E 02	0.	6.5666015E 02	0.	-5.99660137E 04	0.
429.00	-4.6663281E 02	0.	6.5666015E 02	0.	-5.99660137E 04	0.
429.00	-4.6663281E 02	0.	6.5666015E 02	0.	-5.99660137E 04	0.
466.00	-4.1920025E 02	0.	1.2644794E 03	0.	-5.3468125E 04	0.
466.00	-4.1920025E 02	0.	1.2644794E 03	0.	-5.3468125E 04	0.
453.00	-4.0126501E 02	0.	1.1761374E 03	0.	-3.2016062E 04	0.
455.00	-1.0392107E 02	0.	7.8820963E 02	0.	-2.1671687E 04	0.
470.00	-6.5096669E 01	0.	6.8051094E 02	0.	-1.0708937E 04	0.
486.00	-2.9987305E 01	0.	6.4005297E 02	0.	-3.0760520E 02	0.
486.00	-2.9987305E 01	0.	6.4005297E 02	0.	-3.0760520E 02	0.
500.00	-1.1507568E 01	0.	3.2333749E 01	0.	-3.07606250E 02	0.
500.00	-1.1507568E 01	0.	3.2333749E 01	0.	-3.07606250E 02	0.
520.00	-4.8828125E -04	0.	1.1822996E 01	0.	-1.1462500E 02	0.
520.00	-4.8828125E -04	0.	1.1822996E 01	0.	-1.1462500E 02	0.
520.00	-4.8828125E -04	0.	1.1822996E 01	0.	-1.1462500E 02	0.
520.00	-4.8828125E -04	0.	4.3828125E -04	0.	5.6250000E -01	0.

Table 4.68 Fuselage Loading Landing Conditions

FUSELAGE SHEAR AND MOMENT PROGRAM - CASE NUMBER 1105 - 12/19/62

ASYMMETRIC LANDING CONDITIONS L-10

OUTPUT

F.S.	FX	FY	FZ	MX	MY	MZ
-70.00	-2.66475145E-01	-1.6097632E 00	-5.9344699E 00	-3.7557634E 01	-1.5439265E 02	3.2581321E 01
0.	-4.45125037E 00	-1.2371295E 01	-1.2371295E 01	-1.0987371E 02	-3.7809622E 02	9.4651143E 01
35.20	-5.9959788E-01	-5.3268304E 00	-2.0700531E 01	-1.6685081E 02	-9.5866253E 02	1.7650205E 02
70.00	-1.5112567E 00	-2.5479877E 01	-6.9506703E 01	-9.9370360E 02	-1.1154544E 03	3.4587731E 02
59.00	-5.2720742E-01	-3.8651471E 01	-1.615171E 02	-3.1364694E 03	-2.0978203E 03	5.8512544E 02
71.00	-5.9966540E-01	-3.887524E 01	-3.79710E 02	-3.0115896E 03	-5.122296E 03	1.3322597E 03
82.00	-1.7401836E 00	-1.2306559E 02	-3.5687059E 02	-6.2486813E 03	-8.706037E 03	2.5237050E 03
91.00	-2.6273546E 00	-1.5275439E 02	-4.3222309E 02	-7.3187442E 03	-1.18951895E 04	3.8537049E 03
110.00	-1.1426142E 00	-2.4918210E 02	-6.5576952E 02	-1.089210E 04	-2.1401880E 04	7.2630800E 03
110.00	-1.4226142E 00	-3.4918210E 02	-6.5576952E 02	-1.089210E 04	-2.1401880E 04	7.2630800E 03
122.00	1.7257202E 01	-3.8591095E 02	-6.5576952E 02	-1.4112071E 04	-3.0725647E 04	1.0829435E 04
136.00	1.7257202E 01	-3.8591095E 02	-6.5576952E 02	-2.0946891E 04	-4.5053554E 04	1.5961153E 04
136.00	1.7257202E 01	-3.8591095E 02	-6.5576952E 02	-2.0946891E 04	-4.5053554E 04	1.5961153E 04
150.00	5.2639594E 01	-5.7313068E 02	-1.356270E 03	-3.9711306E 04	-7.1453663E 04	2.3644031E 04
165.00	5.8257295E 01	-6.4157269E 02	-2.7297145E 03	-5.3733554E 04	-1.0903235E 05	3.4628575E 04
177.00	7.3473420E 01	-1.1129407E 03	-5.324241E 03	-3.5508928E 04	-1.4540915E 05	4.8296962E 04
168.00	1.0169765E 02	-1.426323E 03	-4.1137669E 03	-7.5313055E 04	-1.9000114E 05	6.118637E 04
201.00	1.279935E 02	-1.551543E 03	-4.321393E 03	-7.8493114E 04	-2.4948198E 05	8.077217E 04
214.00	1.722223E 02	-1.6556402E 03	-5.033333E 03	-3.5093409E 04	-3.0959473E 05	1.0026735E 05
214.00	2.081324E 02	-3.3566493E 03	-1.129453E 03	-3.2124913E 05	-3.0997803E 05	-4.8339048E 05
256.00	4.850932E 02	-3.874117E 03	-5.75105E 03	-3.5682850E 05	-5.9108666E 05	2.397632E 05
266.00	3.850937E 03	-4.6243527E 03	-1.65105E 04	-3.7332747E 05	-6.4739299E 05	1.522105E 05
287.00	3.850937E 03	-4.6243527E 03	-1.65105E 04	-3.7332747E 05	-6.4739299E 05	1.522105E 05
296.00	3.850937E 03	-4.6243527E 03	-1.65105E 04	-3.7332747E 05	-6.4739299E 05	1.522105E 05
296.00	3.850937E 03	-4.6243527E 03	-1.65105E 04	-3.7332747E 05	-6.4739299E 05	1.522105E 05
315.00	3.850937E 03	-4.6243527E 03	-1.65105E 04	-3.7332747E 05	-6.4739299E 05	1.522105E 05
315.00	3.850937E 03	-4.6243527E 03	-1.65105E 04	-3.7332747E 05	-6.4739299E 05	1.522105E 05
315.00	3.850937E 03	-4.6243527E 03	-1.65105E 04	-3.7332747E 05	-6.4739299E 05	1.522105E 05
322.00	1.490787E 02	-1.1229949E 03	-2.0706624E 03	-4.1037908E 04	-2.7698692E 05	7.2262500E 04
341.00	-1.125842E 02	9.1736601E 02	2.340423E 03	3.4758862E 04	-2.4394479E 05	5.8750939E 04
366.00	-1.110655E 02	5.5566266E 02	1.720967E 03	2.602432E 04	-1.6254176E 05	4.383151E 04
366.00	-1.0826934E 02	3.9274437E 02	1.376451E 03	2.183521E 04	-1.1996597E 05	2.8547801E 04
352.00	-1.056674E 02	3.0536437E 02	1.095991E 03	2.3183521E 04	-1.1996597E 05	1.266832E 04
407.00	-1.056674E 02	3.0536437E 02	1.095991E 03	1.9314289E 04	-9.8806187E 04	7.7754435E 03
419.00	-1.056674E 02	2.6073040E 02	1.2310751E 03	1.6319678E 04	-8.3037000E 04	4.8560570E 03
429.00	-1.055393E 02	1.4446933E 02	1.133991E 03	1.6319678E 04	-7.0888593E 04	2.7675781E 03
429.00	-1.055393E 02	9.051641E 01	1.09201E 03	1.6319678E 04	-7.0888593E 04	2.7675781E 03
446.00	-1.031390E 02	3.7585443E 02	1.171246E 03	1.6238262E 04	-4.0290406E 04	1.623562E 03
455.00	-1.032536E 02	1.735103E 02	1.06310E 03	1.6034894E 04	-2.5516562E 04	1.365281E 03
455.00	-1.032536E 02	1.735103E 02	1.06310E 03	1.6034894E 04	-2.5516562E 04	1.365281E 03
470.00	-1.032536E 02	2.8344269E 01	7.755735E 02	6.202332E 04	-1.7622219E 04	6.1219531E 03
486.00	-1.274030E 00	-1.4484471E 01	7.306552E 02	2.1237852E 04	-7.3334374E 04	4.7815654E 03
486.00	-1.274030E 00	3.9099763E 01	5.33124E 02	3.1237852E 04	-7.3334374E 04	4.7815654E 03
500.00	-4.710229E-01	1.549310E 01	2.358355E 01	6.6943359E 03	-2.3571875E 04	1.5398437E 04
520.00	8.0871862E-04	4.8521771E-03	-7.1615333E-03	1.09937500E-01	-2.8125090E-01	-1.83625000E 00

Table 4.69 Fuselage Loading Landing Conditions

FUSELAGE SHEAR AND MOMENT PROGRAM - JOB NUMBER 1105 - 12/19/62

ASYMMETRIC LANDING CONDITION L-20

OUTPUT

F.S.	FX	FY	FZ	MX	MY	MZ
-70.00	-0.	-0.	-0.	0.	0.	-0.
0.	-1.3217208E-01	-2.5875785E 00	-7.9032795E 00	-5.9725921E 01	-2.1896054E 02	6.2622077E 01
20.00	-1.7702397E-01	-6.6461705E 00	-2.0157884E 01	-1.5406185E 02	-3.1162455E 02	1.5744777E 02
35.20	-1.9712242E-01	-8.8210001E 00	-2.5904288E 01	-2.2010372E 02	-8.6755520E 02	2.7623325E 02
47.00	-4.0090821E-01	-3.2315810E 01	-8.2261962E 01	-1.1208352E 03	-1.4635305E 03	5.0963051E 02
59.00	1.1563067E 00	-7.1832168E 01	-2.1115508E 02	-3.3947795E 03	-2.6810895E 03	6.3905693E 02
71.00	2.0327480E 00	-1.1090223E 02	-3.2111405E 02	-5.3799379E 03	-6.2251021E 03	1.8302762E 03
82.60	2.1766435E 00	-1.5034775E 02	-4.0905705E 02	-6.7053590E 03	-1.0380499E 04	3.3623036E 03
91.00	1.8228227E 00	-1.8323712E 02	-4.7022054E 02	-7.8401904E 03	-1.4009098E 04	4.7199344E 03
110.00	5.2364966E 00	-2.9211865E 02	-7.4589750E 02	-1.1543367E 04	-2.4916342E 04	9.1349562E 03
122.50	8.7283183E 00	-3.7392138E 02	-9.5990610E 02	-1.4908746E 04	-3.5410582E 04	1.3200957E 04
136.50	2.5364608E 01	-5.5749183E 02	-1.5663408E 03	-2.1883646E 04	-5.1376834E 04	1.9121442E 04
136.50	2.5364608E 01	-5.5749183E 02	-1.5663408E 03	-2.1883646E 04	-5.1376834E 04	1.9121442E 04
150.00	5.9173337E 01	-7.6391544E 02	-2.4864154E 03	-3.0772042E 04	-8.015912E 04	2.8123085E 04
165.20	6.5828153E 01	-9.4525753E 02	-2.8949730E 03	-3.4873772E 04	-1.2055594E 05	4.0888507E 04
177.20	7.8857043E 01	-1.1763525E 03	-3.4686946E 03	-4.0215547E 04	-1.5644300E 05	5.5344425E 04
188.90	1.0208762E 02	-1.4339571E 03	-4.2068217E 03	-4.5662344E 04	-2.0288019E 05	6.8772253E 04
201.90	1.1697687E 02	-1.5184162E 03	-4.5555340E 03	-4.8492245E 04	-2.5984163E 05	8.6043507E 04
214.00	1.313996E 02	-1.5243170E 03	-5.0747647E 03	-5.3938524E 04	-3.1575281E 05	1.0641232E 05
214.00	2.1432368E 02	-3.2515073E 03	-1.9226156E 03	-3.2140886E 05	-5.1647415E 05	1.0730301E 05
266.00	4.5697033E 02	-3.7325411E 03	-5.923727E 03	-3.5726445E 05	-6.1072491E 05	2.4477833E 05
266.00	3.7690445E 03	4.7666588E 03	1.1867472E 04	3.7288753E 05	-6.6723125E 05	1.5723535E 05
287.00	3.7959464E 03	4.459981E 03	1.1053574E 04	3.7094178E 05	-6.5377191E 05	1.5202100E 05
296.50	3.8236982E 03	4.0305655E 03	1.0130381E 04	3.6823100E 05	-5.4724172E 05	1.0895278E 05
296.50	3.8236982E 03	2.0036269E 03	1.0203596E 04	4.5061554E 04	-5.4724172E 05	1.0895278E 05
315.89	3.8525014E 03	1.4577762E 03	9.1931324E 03	3.9346470E 04	-3.5496476E 05	7.2953818E 04
315.89	-1.5163602E 02	1.4577762E 03	3.5212679E 03	3.7346470E 04	-2.8689442E 05	7.2953818E 04
328.10	-1.4617290E 02	1.2857272E 03	3.2211386E 03	3.6260013E 04	-2.4577581E 05	5.6235663E 04
341.00	-1.3690520E 04	1.1222100E 03	2.9101401E 03	3.3694447E 04	-2.0574320E 05	4.0506449E 04
366.00	-9.8192687E 01	5.3395294E 02	1.7105090E 03	2.7740910E 04	-1.4784123E 05	1.9991937E 04
392.12	-8.9292274E 01	3.4266888E 02	1.3708213E 03	2.5346473E 04	-1.0846505E 05	8.7190524E 03
392.12	-8.9292274E 01	3.4266888E 02	1.3708213E 03	2.5346473E 04	-1.0846505E 05	8.7190524E 03
407.00	-8.749069E 01	2.5841412E 02	1.2480505E 03	2.1482619E 04	-8.9115312E 04	4.3292576E 03
419.00	-8.6644073E 01	1.6372284E 02	1.1247655E 03	1.9444502E 04	-7.4714875E 04	1.6665312E 03
429.23	-8.5807457E 01	1.0322656E 02	1.0432830E 03	1.8548274E 04	-6.3635219E 04	3.0509375E 02
429.23	-8.5807457E 01	2.5994992E 01	1.5328009E 03	1.6548274E 04	-6.3635219E 04	3.0509375E 02
446.55	-8.3512291E 01	-2.3793315E 01	1.5480149E 03	1.8345916E 04	-3.6039281E 04	2.4126552E 02
455.22	-8.2702011E 01	-4.272717E 01	1.51666407E 03	1.8301133E 04	-2.2724344E 04	5.0799216E 02
455.22	-4.3687577E 00	4.4543714E 01	7.7597715E 02	1.5746020E 02	-2.2724344E 04	5.0799216E 02
470.80	-2.6793365E 00	1.6500537E 00	7.0756482E 02	6.5271484E 01	-1.2351566E 04	1.8714042E 02
486.39	-1.2024765E 00	-3.9434131E 01	6.4450256E 02	2.1827148E 01	-6.6525000E 02	4.5250000E 02
486.39	-1.2024765E 00	3.697433E 01	5.4384649E 01	2.1827148E 01	-6.6525000E 02	4.5250000E 02
500.00	-4.5098114E-01	1.4647583E 01	2.1366455E 01	6.4892578E 00	-2.1375000E 02	1.4642187E 02
520.00	3.8909912E-04	2.8076172E-03	-1.3427734E-03	5.0781250E-02	-2.1875000E-01	-9.8437500E-01

Table 4.70 Fuselage Loading Landing Conditions

4.5.5 Parachute Conditions

A detailed study of the fuselage loading from two spin-with-parachute conditions and six high-speed parachute conditions has been made. For the spin-parachute conditions, the parachute loads are superimposed upon the loads resulting from a 2.0 g steep spin condition. The high-speed drag parachute loads are applied to the structure in addition to those imposed by a 1.0 g level flight condition. The applied parachute loads and the resulting airplane linear load-factors and angular accelerations are listed in Table 4.71.

Figure 4.40 shows calculated fuselage bending moment curves for the four unsymmetrical parachute conditions. Figure 4.41 presents fuselage vertical bending moment envelope curves. The parachute conditions which produce the positive M_y envelope curves are indicated at the top of the figure and those which produce the negative M_y envelope, at the bottom.

The curves of Figure 4.42 give values of the fuselage moment envelope for the unsymmetrical parachute conditions. The parachute conditions which produce critical torsional (M_x) and resultant bending moments (M_R) along the length of the fuselage are shown in conjunction with each curve. The resultant moment M_R is defined as

$$M_R = \sqrt{M_y^2 + M_z^2}$$

where the values of M_y and M_z are those which produce the maximum value of M_R and are not necessarily the maximum values of M_y or M_z .

Tabular values of the fuselage distributed loads are given in Tables 4.72 through 4.79 for all eight of the parachute conditions.

XV-5A SPIN-WITH-PARACHUTE AND HIGH-SPEED PARACHUTE CONDITIONS

FORM: 71FF

PARACHUTE FORCES ARE LISTED AT F.S. 496.37, W.L. 113.0, D.L. 0.0

COND No.	CONDITION	CG STA	CHUTE F _z LBS.	CHUTE F _y LBS.	CHUTE F _x LBS.	CHUTE M _z IN-LBS.	CHUTE M _y IN-LBS.	CHUTE M _x IN-LBS.	V _x	V _y	V _z	$\dot{\psi}$ R/SEC ²	$\ddot{\theta}$ R/SEC ²	$\ddot{\psi}$ R/SEC ²
SPC-1	STEEP SPIN WITH PARACHUTE	240.0	574	-292	877	-1128	-18179	-5779	.065	.011	2.277	-1.577	-8.35	-1.07
SPC-2	STEEP SPIN WITH PARACHUTE	246.0	594	-292	802	-1128	-18179	-5779	.065	.011	2.087	-1.64	-7.42	-1.05
HSC-1	HIGH SPEED DECK PARACHUTE	246.0	16597	0	0	0	-64263	0	1.814	0	1.0	0	-33	0
HSC-2	HIGH SPEED DECK PARACHUTE	246.0	1597	0	0	0	-64263	0	1.804	0	1.0	0	-39	0
HSC-3	HIGH SPEED DECK PARACHUTE	240.0	14133	232	2091	8617	-5808	3773	1.536	.243	1.227	.73	-3.05	2.65
HSC-4	HIGH SPEED DECK PARACHUTE	246.0	14133	232	2091	8617	-5808	3773	1.536	.243	1.227	.81	-2.24	2.51
HSC-5	HIGH SPEED DECK PARACHUTE	240.0	14043	0	4252	0	-4911	0	1.744	0	1.462	0	-6.02	0
HSC-6	HIGH SPEED DECK PARACHUTE	246.0	14043	0	4252	0	-4911	0	1.744	0	1.462	0	-5.72	0

Table 4.71 XV-5A Spin-With-Parachute and High-Speed Parachute Conditions

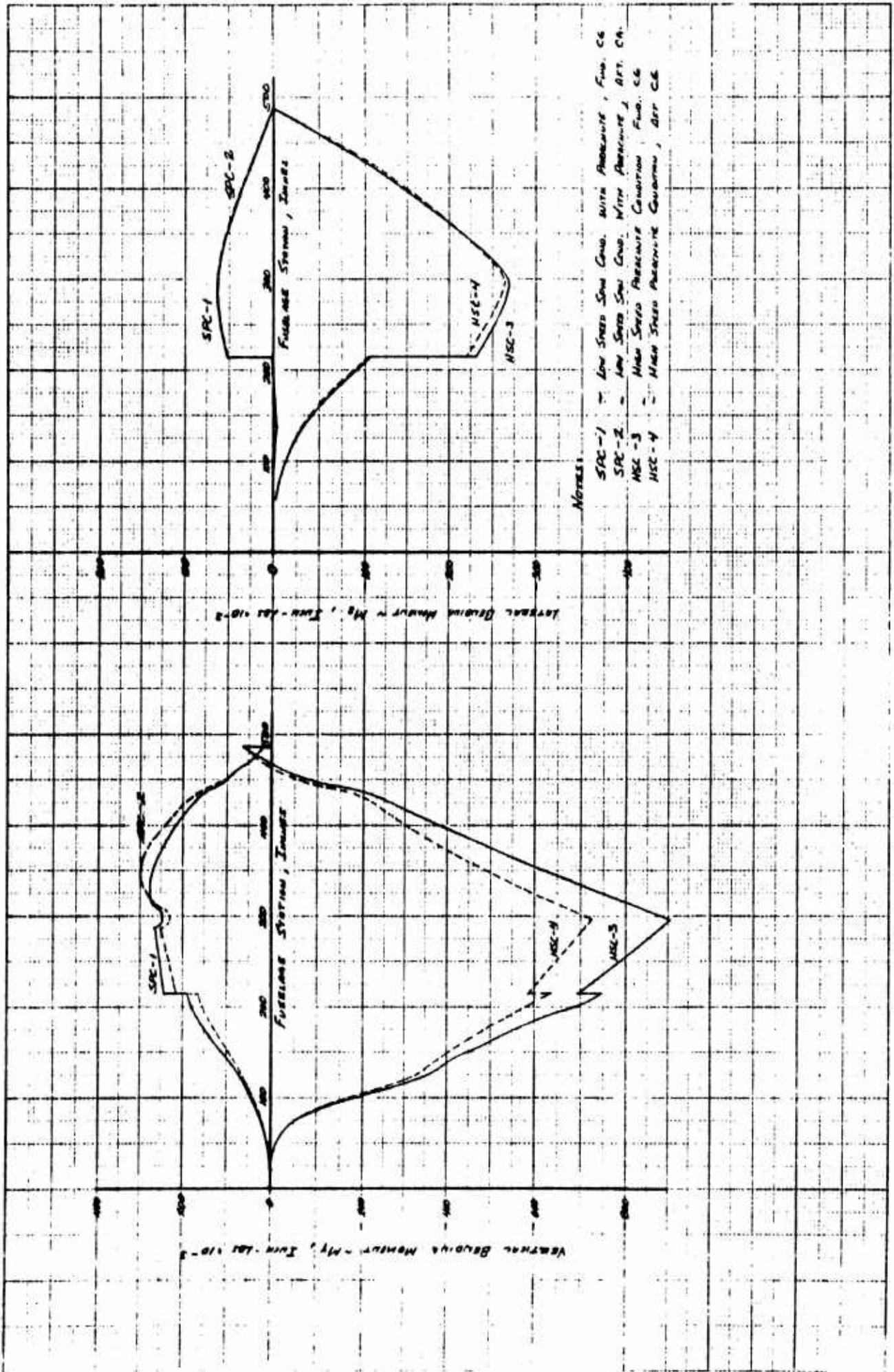

Figure 4.40 Fuselage Bending Moment Curves Unsymmetrical Axis and Parachute Conditions

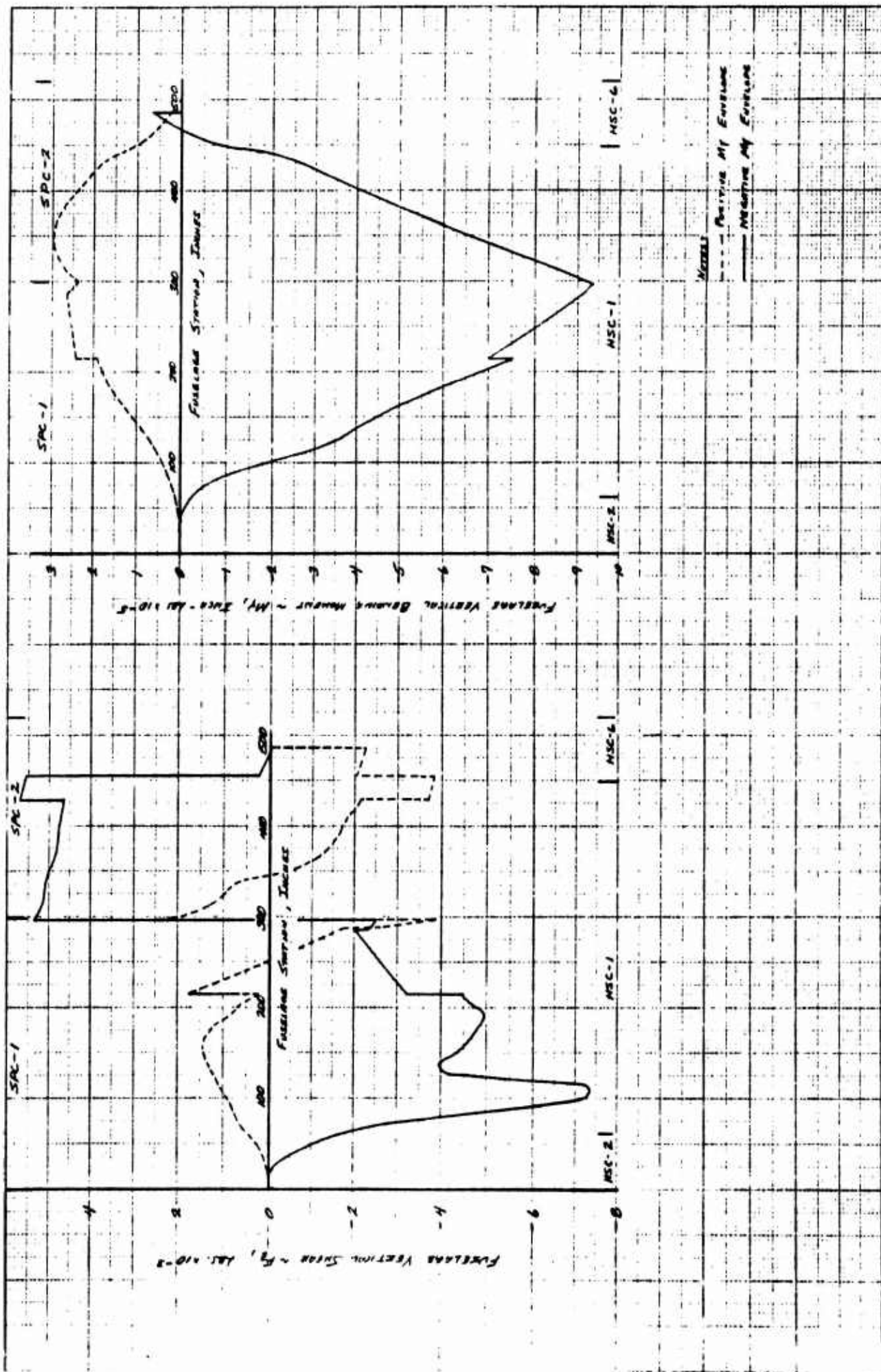

Figure 4.41 Fuselage Loading Envelope Curves Fuselage Vertical Loading From Spin and Parachute Conditions

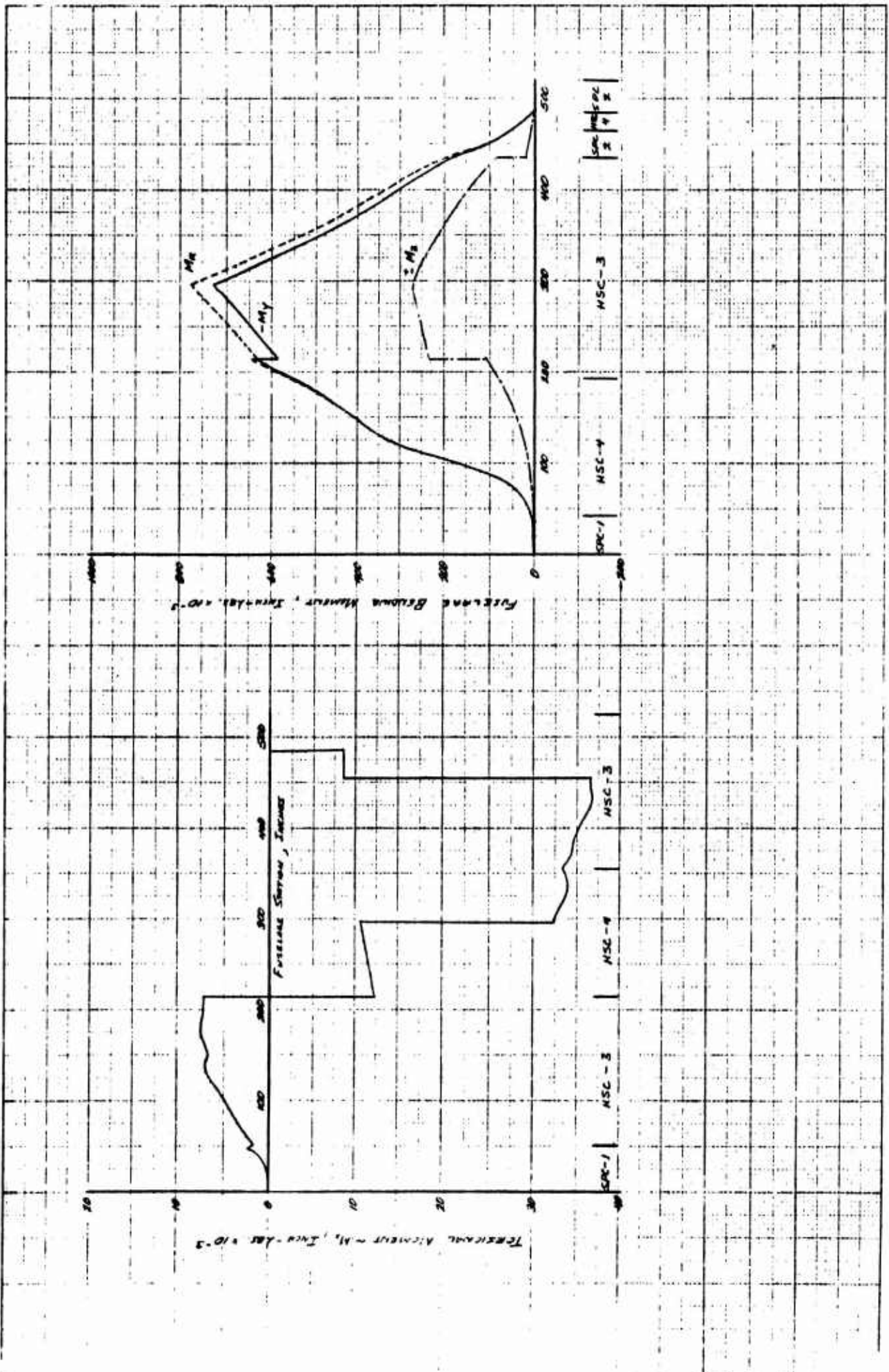

Figure 4.42 Fuselage Moment Envelope Curves Unsymmetrical Spin and Parachute Conditions

ASYMMETRIC FLIGHT CONDITION ██████████ SPC-1

OUTPUT

F.S.	FX	FY	FZ	MX	MY	MZ
-70.00	-3.6360727E 00	-4.3872907E 00	2.4742357E 01	-9.9327286E 01	8.6509532E 02	1.3598277E 02
0.	-7.8997421E 00	1.4732041E 01	7.5130935E 01	3.0317024E 02	1.7659617E 03	6.1344444E 01
20.00	-9.7999260E 00	3.5220600E 01	1.2686637E 02	7.1482129E 02	3.3556572E 03	3.1644723E 02
35.20	-2.7763397E 01	1.2011598E 02	2.4467213E 02	2.3840883E 03	6.4202757E 03	-3.8642744E 02
47.00	-5.6450676E 01	4.9852135E 01	4.4425339E 02	1.0044927E 03	1.0642103E 04	-1.0910088E 03
59.00	-8.3007364E 01	-9.7845326E 00	5.2047096E 02	2.1913722E 02	1.5226196E 04	-1.1356205E 03
71.00	-1.0618544E 02	-5.4853370E 01	7.4466734E 02	-4.1717182E 02	2.6727458E 04	-1.3692393E 03
82.60	-1.2431649E 02	4.2847616E 01	8.2435397E 02	1.2079959E 03	3.8026525E 04	-1.6764343E 03
91.00	-1.7652871E 02	5.6965686E 01	1.0485751E 03	1.5609960E 03	5.3087657E 04	-2.5985523E 03
110.00	-1.7662871E 02	5.6965686E 01	1.0485751E 03	1.5609960E 03	5.3087657E 04	-2.5985523E 03
122.50	-2.1137415E 02	5.7948396E 01	1.1735850E 03	1.8904379E 03	6.8345671E 04	-3.4036710E 03
136.50	-2.6622259E 02	2.7196697E 01	1.3207660E 03	1.9511445E 03	8.8491237E 04	-4.1367452E 03
150.00	-3.0470865E 02	-5.9182724E 01	1.4079735E 03	1.6617006E 03	1.1087355E 05	-3.3515681E 03
165.20	-3.6056177E 02	-4.5679339E 01	1.5044946E 03	2.0498533E 03	1.3382952E 05	-2.5254105E 03
177.20	-4.3599430E 02	-6.7147770E 01	1.6302620E 03	2.2578720E 03	1.5171301E 05	-1.7728667E 03
188.90	-4.5357133E 02	-9.6712946E 01	9.5974092E 02	2.4617110E 03	1.6700748E 05	-7.7756201E 02
201.90	-4.9382229E 02	-9.5462744E 01	6.7309514E 02	2.6872359E 03	1.87898187E 05	5.4316959E 02
214.00	-4.1330538E 02	-1.2906660E 02	2.3221045E 02	2.9666388E 03	1.8990303E 05	1.8531289E 03
214.00	9.2908988E 02	-2.7312559E 01	1.7385717E 03	6.7163999E 03	2.42202934E 05	5.2737239E 04
286.00	1.4376018E 03	-9.5782446E 01	-1.7324242E 03	5.5611026E 03	2.66446324E 05	6.2567525E 04
286.00	1.4376018E 03	-9.5782446E 01	-1.7324242E 03	5.5611026E 03	2.66446324E 05	6.2567525E 04
287.00	1.4303956E 03	-7.4149914E 00	-1.7324242E 03	9.7341080E 03	2.66446324E 05	6.2567525E 04
296.50	1.4377588E 03	-9.5782446E 01	-1.7324242E 03	1.0125543E 04	2.66446324E 05	6.2567525E 04
296.50	1.4377588E 03	-9.5782446E 01	-1.7324242E 03	1.0125543E 04	2.66446324E 05	6.2567525E 04
315.89	1.3902503E 03	2.0180062E 02	4.1685398E 02	-3.4464385E 03	2.4717605E 05	6.0935108E 04
315.89	1.3902503E 03	2.0180062E 02	4.1685398E 02	-3.4464385E 03	2.4717605E 05	6.0935108E 04
328.10	1.3675771E 03	2.3190966E 02	4.1685398E 02	-8.7496518E 03	2.7514143E 05	5.8306173E 04
341.00	1.3453743E 03	2.6395074E 02	-2.4189746E 02	-8.4441229E 03	2.7461989E 05	5.2150855E 04
366.00	1.2756408E 03	3.4934347E 02	-1.0790018E 03	-6.8295693E 03	2.7461989E 05	4.7825760E 04
392.12	1.2572199E 03	3.8555445E 02	-1.3974003E 03	-5.3297345E 03	2.8759692E 05	4.7825760E 04
392.12	1.2572199E 03	3.8555445E 02	-1.3974003E 03	-5.3297345E 03	2.8759692E 05	4.7825760E 04
407.00	1.2619442E 03	4.0756687E 02	-1.5784487E 03	-5.8066693E 03	1.2671562E 05	1.8684903E 04
419.00	1.2345022E 03	4.3036922E 02	-1.7607791E 03	-5.3815293E 03	2.04461501E 05	3.2901166E 04
429.23	1.2270533E 03	4.4593160E 02	-1.9123965E 03	-5.1757088E 03	1.6662321E 05	2.3427985E 04
429.23	1.2270533E 03	4.4593160E 02	-1.9123965E 03	-5.1757088E 03	1.6662321E 05	2.3427985E 04
446.35	1.2271106E 03	4.1699514E 02	-3.4204300E 03	-5.1856430E 03	1.0833486E 05	1.6313655E 04
455.22	1.2270032E 03	4.2473022E 02	-3.5462739E 03	-5.1856430E 03	1.0833486E 05	1.6313655E 04
470.80	1.5444391E 03	2.1302394E 02	-1.4668719E 03	1.1252163E 03	7.6552010E 04	1.2655947E 04
486.39	1.5431947E 03	2.2574955E 02	-1.4776130E 03	1.1252163E 03	4.4552010E 04	9.4432266E 03
486.39	1.5431947E 03	2.2574955E 02	-1.4776130E 03	1.1252163E 03	4.4552010E 04	9.4432266E 03
486.39	1.5431947E 03	2.2574955E 02	-1.4776130E 03	1.1252163E 03	4.4552010E 04	9.4432266E 03
500.00	2.1369076E 03	-1.1527261E 01	9.7752445E 01	-4.20256105E 03	1.6825875E 04	5.3556902E 03
500.00	2.1364015E 03	-4.6229489E 00	4.1959604E 01	-3.0123391E 03	-1.2551450E 03	-1.4330981E 02
520.00	2.1360033E 03	-2.7465820E 04	-1.4648437E 03	-3.9965820E 03	-4.4545470E 03	-4.4386108E 02
520.00	2.1360033E 03	-2.7465820E 04	-1.4648437E 03	-3.9965820E 03	-4.4545470E 03	-4.4386108E 02

Table 4.72 Fuselage Loading Flight Parachute Conditions

FUSELAGE SHEAR AND MOMENT PROGRAM - JOB NUMBER 1105 - 21 MAY 1963

ASYMMETRIC FLIGHT CONDITION SRC-2

OUTPUT

F.S.#	FX	FY	FZ	MX	MY	MZ
-70.00	-0.	-0.	-0.	-0.	-0.	-0.
0.	0.	0.	0.	0.	0.	0.
20.00	-3.3992510E 00	-4.3604599E 00	2.1197231E 01	-9.8171031E 01	7.4929715E 02	1.3505823E 02
35.20	-7.4145976E 00	1.4774221E 01	6.7563402E 01	3.0411062E 02	1.5283551E 03	5.9605503E 01
47.00	9.2049211E 00	3.5265846E 01	1.1767624E 02	7.1587641E 02	2.9864168E 04	-3.1879696E 02
59.00	-2.6125632E 01	1.5016035E 02	2.2000000E 02	2.3562473E 03	5.5895375E 03	-7.0017549E 02
71.00	-3.3703170E 01	4.7752121E 01	3.0000000E 02	1.0089407E 03	9.0246512E 03	-1.0000000E 03
82.50	-1.0104948E 02	-8.9541658E 00	5.0000000E 02	2.2540009E 02	1.5384767E 04	-1.141072E 03
91.00	-1.1808300E 02	-5.4514355E 01	6.0000000E 02	-4.1196744E 02	2.3867559E 04	-1.0000000E 03
110.00	-1.6876589E 02	4.2469005E 01	7.0000000E 02	1.2130357E 03	3.0133225E 04	-1.6774055E 03
122.50	-1.6876589E 02	5.0000000E 01	8.0000000E 02	1.5839773E 03	4.7162570E 04	-2.6593482E 03
136.50	-2.0208715E 02	3.0000000E 01	9.0000000E 02	1.5839773E 03	6.0615090E 04	-3.3794433E 03
150.00	-2.6125632E 01	2.0000000E 01	1.0000000E 03	1.6872579E 03	7.8004633E 04	-4.0064605E 03
165.00	-3.0606162E 02	3.0000000E 01	1.0000000E 03	1.5844647E 03	9.6687888E 04	-4.225202E 03
177.00	-3.5992026E 02	4.0000000E 01	1.0000000E 03	2.0049165E 03	1.1544838E 05	-2.2854123E 03
188.00	-4.6113575E 02	5.0000000E 01	1.0000000E 03	2.3789243E 03	1.2954836E 05	-1.320303E 02
201.00	-5.0000000E 02	6.0000000E 01	1.0000000E 03	2.8383251E 03	1.4231326E 05	-8.3504370E 02
214.00	-5.5944309E 02	7.0000000E 01	1.0000000E 03	3.1243942E 03	1.5194860E 05	4.504707E 03
226.00	-6.128907E 02	8.0000000E 01	1.0000000E 03	3.4203144E 03	1.6147359E 05	1.5402354E 03
238.00	-6.663375E 02	9.0000000E 01	1.0000000E 03	3.7211305E 03	1.7151465E 05	5.124101E 04
250.00	-7.197843E 02	1.0000000E 02	1.0000000E 03	4.0217732E 04	1.8246471E 05	9.1240000E 04
262.00	-7.732311E 02	1.1000000E 02	1.0000000E 03	4.3217732E 04	1.9346471E 05	1.2400000E 04
274.00	-8.266779E 02	1.2000000E 02	1.0000000E 03	4.6217732E 04	2.0464716E 05	1.5600000E 04
286.00	-8.801247E 02	1.3000000E 02	1.0000000E 03	4.9217732E 04	2.1583164E 05	1.8800000E 04
298.00	-9.335715E 02	1.4000000E 02	1.0000000E 03	5.2217732E 04	2.2701612E 05	2.2000000E 04
310.00	-9.870183E 02	1.5000000E 02	1.0000000E 03	5.5217732E 04	2.3820060E 05	2.5200000E 04
322.00	-1.040451E 02	1.6000000E 02	1.0000000E 03	5.8217732E 04	2.4938508E 05	2.8400000E 04
334.00	-1.090719E 02	1.7000000E 02	1.0000000E 03	6.1217732E 04	2.6056956E 05	3.1600000E 04
346.00	-1.140987E 02	1.8000000E 02	1.0000000E 03	6.4217732E 04	2.7175404E 05	3.4800000E 04
358.00	-1.191255E 02	1.9000000E 02	1.0000000E 03	6.7217732E 04	2.8293852E 05	3.8000000E 04
370.00	-1.241523E 02	2.0000000E 02	1.0000000E 03	7.0217732E 04	2.9412300E 05	4.1200000E 04
382.00	-1.291791E 02	2.1000000E 02	1.0000000E 03	7.3217732E 04	3.0530748E 05	4.4400000E 04
394.00	-1.342059E 02	2.2000000E 02	1.0000000E 03	7.6217732E 04	3.1649196E 05	4.7600000E 04
406.00	-1.392327E 02	2.3000000E 02	1.0000000E 03	7.9217732E 04	3.2767644E 05	5.0800000E 04
418.00	-1.442595E 02	2.4000000E 02	1.0000000E 03	8.2217732E 04	3.3886092E 05	5.4000000E 04
430.00	-1.492863E 02	2.5000000E 02	1.0000000E 03	8.5217732E 04	3.5004540E 05	5.7200000E 04
442.00	-1.543131E 02	2.6000000E 02	1.0000000E 03	8.8217732E 04	3.6122988E 05	6.0400000E 04
454.00	-1.593399E 02	2.7000000E 02	1.0000000E 03	9.1217732E 04	3.7241436E 05	6.3600000E 04
466.00	-1.643667E 02	2.8000000E 02	1.0000000E 03	9.4217732E 04	3.8359884E 05	6.6800000E 04
478.00	-1.693935E 02	2.9000000E 02	1.0000000E 03	9.7217732E 04	3.9478332E 05	7.0000000E 04
490.00	-1.744203E 02	3.0000000E 02	1.0000000E 03	1.00217732E 05	4.0596780E 05	7.3200000E 04
502.00	-1.794471E 02	3.1000000E 02	1.0000000E 03	1.03217732E 05	4.1715228E 05	7.6400000E 04
514.00	-1.844739E 02	3.2000000E 02	1.0000000E 03	1.06217732E 05	4.2833676E 05	7.9600000E 04
526.00	-1.895007E 02	3.3000000E 02	1.0000000E 03	1.09217732E 05	4.3952124E 05	8.2800000E 04
538.00	-1.945275E 02	3.4000000E 02	1.0000000E 03	1.12217732E 05	4.5070572E 05	8.6000000E 04
550.00	-2.0000000E 02	3.5000000E 02	1.0000000E 03	1.15217732E 05	4.6189020E 05	8.9200000E 04
562.00	-2.0500000E 02	3.6000000E 02	1.0000000E 03	1.18217732E 05	4.7307468E 05	9.2400000E 04
574.00	-2.1000000E 02	3.7000000E 02	1.0000000E 03	1.21217732E 05	4.8425916E 05	9.5600000E 04
586.00	-2.1500000E 02	3.8000000E 02	1.0000000E 03	1.24217732E 05	4.9544364E 05	9.8800000E 04
598.00	-2.2000000E 02	3.9000000E 02	1.0000000E 03	1.27217732E 05	5.0662812E 05	1.0200000E 05
610.00	-2.2500000E 02	4.0000000E 02	1.0000000E 03	1.30217732E 05	5.1781260E 05	1.0600000E 05
622.00	-2.3000000E 02	4.1000000E 02	1.0000000E 03	1.33217732E 05	5.2900000E 05	1.1000000E 05
634.00	-2.3500000E 02	4.2000000E 02	1.0000000E 03	1.36217732E 05	5.4018448E 05	1.1400000E 05
646.00	-2.4000000E 02	4.3000000E 02	1.0000000E 03	1.39217732E 05	5.5136896E 05	1.1800000E 05
658.00	-2.4500000E 02	4.4000000E 02	1.0000000E 03	1.42217732E 05	5.6255344E 05	1.2200000E 05
670.00	-2.5000000E 02	4.5000000E 02	1.0000000E 03	1.45217732E 05	5.7373792E 05	1.2600000E 05
682.00	-2.5500000E 02	4.6000000E 02	1.0000000E 03	1.48217732E 05	5.8492240E 05	1.3000000E 05
694.00	-2.6000000E 02	4.7000000E 02	1.0000000E 03	1.51217732E 05	5.9610688E 05	1.3400000E 05
706.00	-2.6500000E 02	4.8000000E 02	1.0000000E 03	1.54217732E 05	6.0729136E 05	1.3800000E 05
718.00	-2.7000000E 02	4.9000000E 02	1.0000000E 03	1.57217732E 05	6.1847584E 05	1.4200000E 05
730.00	-2.7500000E 02	5.0000000E 02	1.0000000E 03	1.60217732E 05	6.2966032E 05	1.4600000E 05
742.00	-2.8000000E 02	5.1000000E 02	1.0000000E 03	1.63217732E 05	6.4084480E 05	1.5000000E 05
754.00	-2.8500000E 02	5.2000000E 02	1.0000000E 03	1.66217732E 05	6.5202928E 05	1.5400000E 05
766.00	-2.9000000E 02	5.3000000E 02	1.0000000E 03	1.69217732E 05	6.6321376E 05	1.5800000E 05
778.00	-2.9500000E 02	5.4000000E 02	1.0000000E 03	1.72217732E 05	6.7439824E 05	1.6200000E 05
790.00	-3.0000000E 02	5.5000000E 02	1.0000000E 03	1.75217732E 05	6.8558272E 05	1.6600000E 05
802.00	-3.0500000E 02	5.6000000E 02	1.0000000E 03	1.78217732E 05	6.9676720E 05	1.7000000E 05
814.00	-3.1000000E 02	5.7000000E 02	1.0000000E 03	1.81217732E 05	7.0795168E 05	1.7400000E 05
826.00	-3.1500000E 02	5.8000000E 02	1.0000000E 03	1.84217732E 05	7.1913616E 05	1.7800000E 05
838.00	-3.2000000E 02	5.9000000E 02	1.0000000E 03	1.87217732E 05	7.3032064E 05	1.8200000E 05
850.00	-3.2500000E 02	6.0000000E 02	1.0000000E 03	1.90217732E 05	7.4150512E 05	1.8600000E 05
862.00	-3.3000000E 02	6.1000000E 02	1.0000000E 03	1.93217732E 05	7.5268960E 05	1.9000000E 05
874.00	-3.3500000E 02	6.2000000E 02	1.0000000E 03	1.96217732E 05	7.6387408E 05	1.9400000E 05
886.00	-3.4000000E 02	6.3000000E 02	1.0000000E 03	1.99217732E 05	7.7505856E 05	1.9800000E 05
898.00	-3.4500000E 02	6.4000000E 02	1.0000000E 03	2.02217732E 05	7.8624304E 05	2.0200000E 05
910.00	-3.5000000E 02	6.5000000E 02	1.0000000E 03	2.05217732E 05	7.9742752E 05	2.0600000E 05
922.00	-3.5500000E 02	6.6000000E 02	1.0000000E 03	2.08217732E 05	8.0861200E 05	2.1000000E 05
934.00	-3.6000000E 02	6.7000000E 02	1.0000000E 03	2.11217732E 05	8.1979648E 05	2.1400000E 05
946.00	-3.6500000E 02	6.8000000E 02	1.0000000E 03	2.14217732E 05	8.3098096E 05	2.1800000E 05
958.00	-3.7000000E 02	6.9000000E 02	1.0000000E 03	2.17217732E 05	8.4216544E 05	2.2200000E 05
970.00	-3.7500000E 02	7.0000000E 02	1.0000000E 03	2.20217732E 05	8.5334992E 05	2.2600000E 05
982.00	-3.8000000E 02	7.1000000E 02	1.0000000E 03	2.23217732E 05	8.6453440E 05	2.3000000E 05
994.00	-3.8500000E 02	7.2000000E 02	1.0000000E 03	2.26217732E 05	8.7571888E 05	2.3400000E 05
1006.00	-3.9000000E 02	7.3000000E 02	1.0000000E 03	2.29217732E 05	8.8690336E 05	2.3800000E 05
1018.00	-3.9500000E 02	7.4000000E 02	1.0000000E 03	2.32217732E 05	8.9808784E 05	2.4200000E 05
1030.00	-4.0000000E 02	7.5000000E 02	1.0000000E 03	2.35217732E 05	9.0927232E 05	2.4600000E 05
1042.00	-4.0500000E 02	7.6000000E 02	1.0000000E 03	2.38217732E 05	9.2045680E 05	2.5000000E 05
1054.00	-4.1000000E 02	7.7000000E 02	1.0000000E 03	2.41217732E 05	9.3164128E 05	2.5400000E 05
1066.00	-4.1500000E 02	7.8000000E 02	1.0000000E 03	2.44217732E 05	9.4282576E 05	2.5800000E 05
1078.00	-4.2000000E 02	7.9000000E 02	1.0000000E 03	2.47217732E 05	9.5401024E 05	2.6200000E 05
1090.00	-4.2500000E 02	8.0000000E 02	1.0000000E 03	2.50217732E 05	9.6519472E 05	2.6600000E 05
1102.00	-4.3000000E 02	8.1000000E 02	1.0000000E 03	2.53217732E 05	9.7637920E 05	2.7000000E 05
1114.00	-4.3500000E 02	8.2000000E 02	1.0000000E 03	2.56217732E 05	9.8756368E 05	2.7400000E 05
1126.00	-4.4000000E 02	8.3000000E 02	1.0000000E 03	2.59217732E 05	9.9874816E 05	2.7800000E 05
1138.00	-4.4500000E 02	8.4000000E 02	1.0000000E 03	2.62217732E 05	1.0095840E 06	2.8200000E 05
1150.00	-4.5000000E 02	8.5000000E 02	1.0000000E 03	2.65217732E 05	1.0216864E 06	2.8600000E 05
1162.00	-4.5500000E 02	8.6000000E 02	1.0000000E 03	2.68217732E 05	1.0337888E 06	2.9000000E 05
1174.00	-4.6000000E 02	8.7000000E 02	1.0000000E 03	2.71217732E 05	1.0458912E 06	2.9400000E 05
1186.00	-4.6500000E 02	8.8000000E 02	1.0000000E 03	2.74217732E 05		

FUSELAGE SHEAR AND MOMENT PROGRAM - JOB NUMBER 1105 - 20 MAY 1963

ASYMMETRIC FLIGHT CONDITION HSC-1

OUTPUT

F.S.	FX	FY	FZ	MX	MY	MZ
-70.00	-0.	-0.	0.	-0.	0.	0.
0.	-1.2049844E 01	-0.	-5.1038384E 00	-0.	1.2535323E 02	0.
20.00	-2.8537641E 01	-0.	-7.9789760E 01	-0.	2.2595444E 02	0.
35.20	-3.5887027E 01	-0.	-4.3091485E 02	-0.	-3.1661703E 03	0.
47.00	-1.0506740E 02	-0.	-9.1958680E 02	-0.	-9.6582670E 03	0.
59.00	-2.5628446E 02	-0.	-1.6170417E 03	-0.	-2.2447918E 04	0.
71.00	-3.8384271E 02	-0.	-2.7688027E 03	-0.	-4.6320776E 04	0.
82.60	-4.8188215E 02	-0.	-4.6018314E 03	-0.	-8.6723992E 04	0.
91.00	-5.4851218E 02	-0.	-6.1854123E 03	-0.	-1.3058365E 05	0.
110.00	-8.3724049E 02	-0.	-7.3621319E 03	-0.	-2.6422962E 05	0.
122.50	-1.0540645E 03	-0.	-7.3621319E 03	-0.	-2.6422962E 05	0.
136.50	-1.6458053E 03	-0.	-5.0968177E 03	-0.	-3.4232726E 05	0.
150.00	-2.5246094E 03	-0.	-3.9552554E 03	-0.	-3.9620537E 05	0.
165.20	-2.9075005E 03	-0.	-4.3475255E 03	-0.	-3.9620537E 05	0.
177.20	-3.5758069E 03	-0.	-4.6810638E 03	-0.	-5.1697698E 05	0.
188.90	-4.3662884E 03	-0.	-4.9538732E 03	-0.	-5.7064219E 05	0.
201.90	-4.8143752E 03	-0.	-5.0393382E 03	-0.	-6.2738726E 05	0.
214.00	-5.4219152E 03	-0.	-4.7637379E 03	-0.	-6.9179387E 05	0.
214.00	-9.9923620E 03	-0.	-4.4935887E 03	-0.	-7.5555927E 05	0.
286.00	-1.3071942E 04	-0.	-3.2286706E 03	-0.	-7.0167370E 05	0.
287.00	-1.3627338E 04	-0.	-1.9968152E 03	-0.	-9.1397607E 05	0.
296.50	-1.4268051E 04	-0.	-1.9968152E 03	-0.	-9.1397607E 05	0.
315.89	-1.4976154E 04	-0.	-2.5061605E 03	-0.	-9.3924404E 05	0.
315.89	-1.4976154E 04	-0.	5.3284410E 03	-0.	-9.3924404E 05	0.
328.10	-1.5169733E 04	-0.	5.1358811E 03	-0.	-8.3384939E 05	0.
341.00	-1.5317792E 04	-0.	5.1358811E 03	-0.	-8.3384939E 05	0.
366.00	-1.5693001E 04	-0.	5.0967071E 03	-0.	-7.47005185E 05	0.
392.12	-1.5837956E 04	-0.	5.0492668E 03	-0.	-7.0308580E 05	0.
392.12	-1.5837956E 04	-0.	4.8567027E 03	-0.	-5.7501377E 05	0.
407.00	-1.5913615E 04	-0.	4.7759548E 03	-0.	-4.4795219E 05	0.
419.00	-1.5988138E 04	-0.	4.7759548E 03	-0.	-4.4795219E 05	0.
429.23	-1.6036695E 04	-0.	4.7285587E 03	-0.	-3.7674629E 05	0.
446.55	-1.6085973E 04	-0.	4.6814368E 03	-0.	-3.1927586E 05	0.
455.22	-1.6103896E 04	-0.	4.6504776E 03	-0.	-2.7106517E 05	0.
470.80	-1.6493594E 04	-0.	8.3863348E 03	-0.	-1.2622430E 05	0.
486.39	-1.65532178E 04	-0.	8.3543947E 03	-0.	-5.3870922E 04	0.
486.39	-1.6566996E 04	-0.	8.3426677E 03	-0.	-5.3870922E 04	0.
500.00	2.59653564E 01	-0.	3.7791066E 03	-0.	5.1189218E 03	0.
500.00	1.1364380E 01	-0.	3.7558916E 03	-0.	6.3829468E 04	0.
520.00	-3.6621094E -04	-0.	2.0034271E 01	-0.	-2.3353125E 02	0.
		-0.	7.7390137E 00	-0.	-8.3421874E 01	0.
		-0.	4.2724609E -04	-0.	-2.0312500E -01	0.

Table 4.74 Fuselage Loading Flight Parachute Conditions

FUSELAGE SHEAR AND MOMENT PROGRAM - JOB NUMBER 1105 - 20 MAY 1963

ASYMMETRIC FLIGHT CONDITION HSC-2

OUTPUT

F.S.	FX	FY	FZ	MX	MY	MZ
-70.00	-0.	-0.	0.	-0.	0.	0.
0.	-1.2082412E 01	-0.	-4.7491265E 00	-0.	1.3696764E 02	0.
20.00	-2.8608940E 01	-0.	-8.0379239E 01	-0.	2.3746074E 02	0.
35.20	-3.5975595E 01	-0.	-4.3242458E 02	-0.	-3.1701154E 03	0.
47.00	-1.0531914E 02	-0.	-9.2032250E 02	-0.	-9.6698111E 03	0.
59.00	-2.5680700E 02	-0.	-1.6153248E 03	-0.	-2.2458327E 04	0.
71.00	-3.8461243E 02	-0.	-2.7651390E 03	-0.	-4.6282519E 04	0.
82.60	-4.8286457E 02	-0.	-4.5969177E 03	-0.	-8.6632086E 04	0.
91.00	-5.4965851E 02	-0.	-6.1797109E 03	-0.	-1.3044326E 05	0.
110.00	-8.3888499E 02	-0.	-7.3532592E 03	-0.	-2.6394118E 05	0.
110.00	-8.3888499E 02	-0.	-7.3532592E 03	-0.	-2.6394118E 05	0.
122.50	-1.0560432E 03	-0.	-5.0863184E 03	-0.	-3.4190490E 05	0.
136.50	-1.6483917E 03	-0.	-3.9384225E 03	-0.	-3.9558707E 05	0.
136.50	-1.6483917E 03	-0.	-3.9384225E 03	-0.	-3.9558707E 05	0.
150.00	-2.5277037E 03	-0.	-4.3207483E 03	-0.	-4.5127102E 05	0.
165.20	-2.8965820E 03	-0.	-4.6428307E 03	-0.	-5.1559849E 05	0.
177.20	-3.4399130E 03	-0.	-4.8451500E 03	-0.	-5.6900580E 05	0.
188.90	-4.0705084E 03	-0.	-4.8418313E 03	-0.	-6.2484069E 05	0.
201.90	-4.3666748E 03	-0.	-4.4845302E 03	-0.	-6.8704243E 05	0.
214.00	-4.7935247E 03	-0.	-4.1158471E 03	-0.	-7.4682068E 05	0.
214.00	-4.7935247E 03	-0.	-4.1158471E 03	-0.	-7.4682068E 05	0.
286.00	-1.2468106E 04	-0.	-1.6948391E 03	0.	-8.298738E 05	0.
286.00	-1.2468106E 04	-0.	-1.6948391E 03	0.	-8.298738E 05	0.
287.00	-1.3056549E 04	-0.	-2.0158841E 03	0.	-8.8735869E 05	0.
296.50	-1.3714956E 04	-0.	-2.2363384E 03	0.	-9.0615277E 05	0.
296.50	-1.3714956E 04	-0.	-2.2363384E 03	0.	-9.0615277E 05	0.
315.89	-1.4423618E 04	-0.	5.5539556E 03	0.	-9.0615277E 05	0.
315.89	-1.4423618E 04	-0.	5.3574715E 03	0.	-7.9639020E 05	0.
328.10	-1.4623841E 04	-0.	5.3584715E 03	0.	-7.9639020E 05	0.
341.00	-1.4839851E 04	-0.	5.3143715E 03	0.	-7.3011096E 05	0.
366.00	-1.5624740E 04	-0.	5.2244824E 03	0.	-6.6224855E 05	0.
392.12	-1.5840091E 04	-0.	4.7744969E 03	0.	-5.4051284E 05	0.
392.12	-1.5840091E 04	-0.	4.6480671E 03	0.	-4.1791996E 05	0.
407.00	-1.5915843E 04	-0.	4.6480671E 03	0.	-4.1791996E 05	0.
419.00	-1.5990495E 04	-0.	4.5997605E 03	0.	-3.4862206E 05	0.
429.23	-1.6039125E 04	-0.	4.5516285E 03	0.	-2.9269927E 05	0.
429.23	-1.6039125E 04	-0.	4.5199646E 03	0.	-2.4581862E 05	0.
446.55	-1.6088414E 04	-0.	7.8728412E 03	0.	-2.4581862E 05	0.
455.22	-1.6106343E 04	-0.	7.8401124E 03	0.	-1.098725E 05	0.
455.22	-1.6106343E 04	-0.	7.8280750E 03	0.	-1.098725E 05	0.
470.80	-1.6532149E 04	-0.	3.4236000E 03	0.	-4.1983516E 04	0.
486.39	-1.6566981E 04	-0.	3.3974699E 03	0.	-4.1983516E 04	0.
486.39	-1.6566981E 04	-0.	3.3735592E 03	0.	1.1065437E 04	0.
500.00	1.1370483E 01	-0.	2.0682648E 01	0.	6.3821375E 04	0.
500.00	1.1370483E 01	-0.	8.0002441E 00	0.	-2.4162500E 02	0.
520.00	-1.2207031E-04	-0.	2.4414062E-04	0.	-8.5906249E 01	0.
520.00	-1.2207031E-04	-0.	2.4414062E-04	0.	-1.2500000E-01	0.

Table 4.75 Fuselage Loading Flight Parachute Conditions

FUSELAGE SHEAR AND MOMENT PROGRAM - JOB NUMBER 1105 - 20 MAY 1963

ASYMMETRIC FLIGHT CONDITION RESULTS

F.S.	FX	FY	FZ	MX	MY	MZ
-70.00	-0.	-0.	0.	-0.	0.	0.
0.	1.0331450E 01	6.1043289E 00	2.3411001E 02	4.5692006E 02	-3.2107573E 02	-3.2107573E 02
20.00	-2.6613693E 01	2.2182693E 01	-5.5688089E 01	4.5810252E 02	9.0658605E 02	-6.6379301E 02
35.20	-3.3422476E 01	2.6982101E 01	-4.0156868E 02	5.4801697E 02	-2.0795720E 03	-1.04677381E 03
47.00	-9.7539948E 01	6.8326278E 01	-8.4485476E 02	1.3240803E 03	-7.9575971E 03	-1.7096126E 03
59.00	-2.3414536E 02	1.5083560E 02	-1.4522399E 03	2.3282345E 03	-1.9689143E 04	-2.9516103E 03
71.00	-3.5015183E 02	2.1797645E 02	-2.5303732E 03	3.2419724E 03	-4.09117631E 04	-5.5927415E 03
82.60	-4.4025043E 02	2.6333332E 02	-4.3130592E 03	3.9846320E 03	-7.8369689E 04	-8.4348644E 03
91.00	-5.0228308E 02	2.9141291E 02	-5.8650673E 03	4.5273529E 03	-1.1979118E 05	-1.0793743E 04
110.00	-7.6233290E 02	3.5948800E 02	-6.9214867E 03	5.7974781E 03	-2.4635903E 05	-1.7320666E 04
110.00	-7.6233290E 02	3.5948800E 02	-6.9214867E 03	5.7974781E 03	-2.4635903E 05	-1.7320666E 04
122.50	-9.4597723E 02	4.6968538E 02	-4.5776811E 03	6.4166495E 03	-3.1833614E 05	-2.2886564E 04
136.50	-1.4718781E 03	6.3027034E 02	-3.2575442E 03	6.9952322E 03	-3.6368266E 05	-3.0635805E 04
136.50	-1.4718781E 03	6.3027034E 02	-3.2575442E 03	6.9952322E 03	-3.6368266E 05	-3.0635805E 04
150.00	-2.5621658E 03	8.4267799E 02	-3.4160930E 03	6.733368E 03	-4.0699288E 05	-4.1683683E 04
165.20	-3.1485929E 03	9.0576433E 02	-3.6748243E 03	7.1835414E 03	-4.5715246E 05	-5.5080380E 04
177.20	-3.1485929E 03	9.0576433E 02	-3.6748243E 03	7.1835414E 03	-4.5715246E 05	-5.5080380E 04
188.90	-3.8282303E 03	1.0478497E 03	-3.8584815E 03	7.4122633E 03	-5.4101143E 05	-7.8662525E 04
201.90	-4.2078660E 03	1.0654898E 03	-3.5587956E 03	7.2390366E 03	-5.8931017E 05	-8.2571287E 04
214.00	-4.6908649E 03	1.0630422E 03	-3.2919791E 03	6.9709706E 03	-6.3549109E 05	-1.0591476E 05
214.00	-4.6908649E 03	1.0630422E 03	-3.2919791E 03	6.9709706E 03	-6.3549109E 05	-1.0591476E 05
266.00	-1.1209248E 04	2.0527642E 02	-1.2489697E 03	-1.0687641E 04	-5.8710695E 05	-2.3185113E 05
266.00	-1.1209248E 04	2.0527642E 02	-1.2489697E 03	-1.0687641E 04	-5.8710695E 05	-2.3185113E 05
286.00	-1.1209248E 04	2.0527642E 02	-1.2489697E 03	-1.0687641E 04	-5.8710695E 05	-2.3185113E 05
287.00	-1.1671233E 04	3.1065590E 01	-1.7264147E 03	-8.1398512E 03	-7.0933510E 05	-2.6814024E 05
296.50	-1.2213387E 04	-1.9535217E 02	-2.1623383E 03	-7.462034E 03	-7.1132967E 05	-2.6901895E 05
296.50	-1.2213387E 04	-1.9535217E 02	-2.1623383E 03	-7.462034E 03	-7.1132967E 05	-2.6901895E 05
315.89	-1.2823839E 04	-1.0269119E 03	4.2955619E 03	-2.8698055E 04	-7.2630416E 05	-2.6982284E 05
315.89	-1.2823839E 04	-1.0269119E 03	4.2955619E 03	-2.8698055E 04	-7.2630416E 05	-2.6982284E 05
328.10	-1.2993979E 04	-1.1136797E 03	4.2355619E 03	-2.9735333E 04	-6.3307299E 05	-2.5403834E 05
341.00	-1.3125743E 04	-1.1881230E 03	4.0489458E 03	-3.0449864E 04	-5.8005820E 05	-2.4101279E 05
341.00	-1.3125743E 04	-1.1881230E 03	4.0489458E 03	-3.0449864E 04	-5.8005820E 05	-2.4101279E 05
366.00	-1.3464186E 04	-1.3998470E 03	3.6464390E 03	-3.1263754E 04	-5.2545970E 05	-2.2630720E 05
392.12	-1.3592073E 04	-1.4971624E 03	3.4676638E 03	-3.4176976E 04	-4.2559420E 05	-1.9376076E 05
392.12	-1.3592073E 04	-1.4971624E 03	3.4676638E 03	-3.4176976E 04	-4.2559420E 05	-1.9376076E 05
407.00	-1.3658626E 04	-1.5532272E 03	3.3635644E 03	-3.5021304E 04	-3.3127542E 05	-1.5614792E 05
419.00	-1.3725793E 04	-1.6132383E 03	3.2560447E 03	-3.5584562E 04	-2.8001505E 05	-1.3344067E 05
429.23	-1.3769063E 04	-1.6540335E 03	3.1838360E 03	-3.6384564E 04	-2.3925756E 05	-1.1454314E 05
429.23	-1.3769063E 04	-1.6540335E 03	3.1838360E 03	-3.6384564E 04	-2.3925756E 05	-1.1454314E 05
446.55	-1.3810415E 04	-1.4056374E 03	7.3712767E 03	-3.6809215E 04	-2.0586790E 05	-9.7839180E 04
455.22	-1.3825498E 04	-1.6224445E 03	7.3422650E 03	-3.6700370E 04	-2.0586790E 05	-9.7839180E 04
455.22	-1.3825498E 04	-1.6224445E 03	7.3422650E 03	-3.6700370E 04	-2.0586790E 05	-9.7839180E 04
470.80	-1.4078553E 04	-1.8710304E 03	2.2878422E 03	-8.6547270E 03	-1.3810125E 04	-6.1677582E 04
486.39	-1.4108027E 04	-1.9073293E 03	2.2272994E 03	-8.6224219E 03	-1.3810125E 04	-6.1677582E 04
486.39	-1.4108027E 04	-1.9073293E 03	2.2272994E 03	-8.6224219E 03	-1.3810125E 04	-6.1677582E 04
500.00	9.6759033E 00	1.3195435E 01	2.1309814E 01	-5.4218750E 00	5.7431859E 04	3.3644814E 03
500.00	9.6759033E 00	1.3195435E 01	2.1309814E 01	-5.4218750E 00	5.7431859E 04	3.3644814E 03
520.00	8.4549219E -04	-7.0953369E -04	-6.7138672E -04	4.9438477E -03	-4.2187500E -01	2.0800781E -01
520.00	8.4549219E -04	-7.0953369E -04	-6.7138672E -04	4.9438477E -03	-4.2187500E -01	2.0800781E -01

Table 4.76 Fuselage Loading Flight Parachute Conditions

FUSELAGE SHEAR AND MOMENT PROGRAM - JOB NUMBER 1105 - 20 MAY 1963

ASYMMETRIC FLIGHT CONDITION HSC-5

OUTPUT

F.S.	FX	FY	FZ	MX	MY	MZ
-70.00	-0.	-0.	0.	-0.	0.	0.
0.	-1.3839323E 01	-0.	1.8091531E 01	-0.	8.8536204E 02	0.
20.00	-3.2286141E 01	-0.	-2.9900661E 01	-0.	1.7932596E 03	0.
35.20	-4.0509136E 01	-0.	-3.7016538E 02	-0.	-7.2069287E 02	0.
47.00	-1.1796540E 02	-0.	-7.6462970E 02	-0.	-5.5839458E 03	0.
59.00	-2.8006376E 02	-0.	-1.2756663E 03	-0.	-1.5641504E 04	0.
71.00	-4.1837431E 02	-0.	-2.2748605E 03	-0.	-3.3527533E 04	0.
82.60	-5.2658454E 02	-0.	-4.0035293E 03	-0.	-6.7361174E 04	0.
91.00	-6.0175245E 02	-0.	-5.5216403E 03	-0.	-1.0568200E 05	0.
110.00	-9.0967196E 02	-0.	-6.4487603E 03	-0.	-2.2380442E 05	0.
110.00	-9.0967196E 02	-0.	-6.4487603E 03	-0.	-2.2380442E 05	0.
122.50	-1.1375665E 03	-0.	-4.0204775E 03	-0.	-2.8859080E 05	0.
136.50	-1.7339403E 03	-0.	-2.5077496E 03	-0.	-3.2393001E 05	0.
136.50	-1.7339403E 03	-0.	-2.5077496E 03	-0.	-3.2393001E 05	0.
150.00	-2.5868585E 03	-0.	-2.4138016E 03	-0.	-3.5393355E 05	0.
165.20	-2.9857827E 03	-0.	-2.5913229E 03	-0.	-3.8688073E 05	0.
177.20	-3.6669950E 03	-0.	-2.6618247E 03	-0.	-4.1320443E 05	0.
188.90	-4.4442812E 03	-0.	-2.5831348E 03	-0.	-4.4041401E 05	0.
201.90	-4.8734629E 03	-0.	-2.2559952E 03	-0.	-4.7141877E 05	0.
214.00	-5.3908468E 03	-0.	-1.9902777E 03	-0.	-5.0091872E 05	0.
214.00	-1.0239358E 04	-0.	-7.5476608E 02	-0.	-4.4375477E 05	0.
286.00	-1.2793345E 04	-0.	-4.0994638E 02	-0.	-4.8126811E 05	0.
286.00	-1.2793345E 04	-0.	-4.0994638E 02	-0.	-4.8126811E 05	0.
287.00	-1.3307888E 04	-0.	-1.0731344E 03	-0.	-4.8169451E 05	0.
296.50	-1.3920182E 04	-0.	-1.7488970E 03	-0.	-4.8984402E 05	0.
296.50	-1.3920182E 04	-0.	-1.7488970E 03	-0.	-4.8984402E 05	0.
315.89	-1.4619805E 04	-0.	4.2395743E 03	-0.	-4.8789716E 05	0.
315.89	-1.4619805E 04	-0.	3.4604094E 03	-0.	-4.0789716E 05	0.
328.10	-1.4817686E 04	-0.	3.4604094E 03	-0.	-4.0789716E 05	0.
341.50	-1.4972357E 04	-0.	3.2440950E 03	-0.	-3.6525998E 05	0.
366.00	-1.5373525E 04	-0.	3.0447168E 03	-0.	-3.2265403E 05	0.
392.12	-1.5522687E 04	-0.	2.4200651E 03	-0.	-2.4997176E 05	0.
392.12	-1.5522687E 04	-0.	2.1374458E 03	-0.	-1.8857269E 05	0.
407.00	-1.5600139E 04	-0.	2.1374458E 03	-0.	-1.8857269E 05	0.
419.00	-1.5679710E 04	-0.	1.9732466E 03	-0.	-1.5746405E 05	0.
429.23	-1.5730550E 04	-0.	1.8016851E 03	-0.	-1.3348783E 05	0.
429.23	-1.5730550E 04	-0.	1.6857297E 03	-0.	-1.1509691E 05	0.
446.55	-1.5776939E 04	-0.	6.3801330E 03	-0.	-1.1509691E 05	0.
455.22	-1.5793895E 04	-0.	6.2556437E 03	-0.	-3.6932499E 03	0.
455.22	-1.5944128E 04	-0.	6.2082911E 03	-0.	4.8356156E 04	0.
470.80	-1.5980838E 04	-0.	7.3807244E 02	-0.	4.8356156E 04	0.
486.39	-1.6014136E 04	-0.	6.3275128E 02	-0.	5.6895281E 04	0.
486.39	-1.6014136E 04	-0.	5.3258429E 02	-0.	6.8007796E 04	0.
500.00	2.8559204E 01	-0.	9.0242546E 01	-0.	-1.1032031E 03	0.
520.00	2.0751953E -03	-0.	3.5720459E 01	-0.	-3.6506250E 02	0.
			-1.8310547E -03	-0.	-8.1250000E -01	0.

Table 4.78 Fuselage Loading Flight Parachute Conditions

FUSELAGE SHEAR AND MOMENT PROGRAM - JOB NUMBER 1105 - 20 MAY 1963

ASYMMETRIC FLIGHT CONDITION HSC-6

OUTPUT

F.S.	FX	FY	FZ	MX	MY	MZ
-70.00	-0.	-0.	0.	-0.	0.	0.
0.	-1.3817363E 01	-0.	1.7304541E 01	-0.	8.5975642E 02	0.
20.00	-3.2259934E 01	-0.	-3.2868683E 01	-0.	1.7295809E 03	0.
35.20	-4.0481017E 01	-0.	-3.7453818E 02	-0.	-8.4106438E 02	0.
47.00	-1.1791651E 02	-0.	-7.7246047E 02	-0.	-5.7854246E 03	0.
59.00	-2.8034941E 02	-0.	-1.2884319E 03	-0.	-1.5960735E 04	0.
71.00	-4.1885923E 02	-0.	-2.2917700E 03	-0.	-3.4047906E 04	0.
82.60	-5.2712212E 02	-0.	-4.0230432E 03	-0.	-6.8097706E 04	0.
91.00	-6.0224013E 02	-0.	-5.5426379E 03	-0.	-1.0659372E 05	0.
110.00	-9.1088195E 02	-0.	-6.4742055E 03	-0.	-2.2517916E 05	0.
122.50	-1.1394950E 03	-0.	-6.4742055E 03	-0.	-2.2517916E 05	0.
136.50	-1.7391781E 03	-0.	-4.0484374E 03	-0.	-2.9033106E 05	0.
136.50	-1.7391781E 03	-0.	-2.5359007E 03	-0.	-3.2613717E 05	0.
150.00	-2.5987378E 03	-0.	-2.4374613E 03	-0.	-3.5607236E 05	0.
165.20	-2.9846081E 03	-0.	-2.6077211E 03	-0.	-3.8993255E 05	0.
177.20	-3.5422008E 03	-0.	-2.6403477E 03	-0.	-4.1689574E 05	0.
188.90	-4.1620444E 03	-0.	-2.4962234E 03	-0.	-4.4450914E 05	0.
201.90	-4.4397835E 03	-0.	-2.0978690E 03	-0.	-4.7485655E 05	0.
214.00	-4.7906365E 03	-0.	-1.7212195E 03	-0.	-5.0240659E 05	0.
214.00	-9.6519375E 03	-0.	-4.9040642E 02	-0.	-4.4509184E 05	0.
286.00	-1.2263615E 04	-0.	-2.4802948E 01	0.	-4.5970371E 05	0.
287.00	-1.2811010E 04	-0.	-6.8766055E 02	0.	-4.5970371E 05	0.
296.50	-1.3443072E 04	-0.	-1.3381465E 03	0.	-4.6040857E 05	0.
296.50	-1.4147396E 04	-0.	4.7978961E 03	0.	-4.6525408E 05	0.
315.89	-1.4147396E 04	-0.	4.0743343E 03	0.	-4.6525408E 05	0.
315.89	-1.4147396E 04	-0.	4.0743343E 03	0.	-3.7220645E 05	0.
328.10	-1.4350637E 04	-0.	3.8644201E 03	0.	-3.7220645E 05	0.
341.00	-1.4558559E 04	-0.	3.5719841E 03	0.	-3.2218093E 05	0.
366.00	-1.5297123E 04	-0.	2.2784542E 03	0.	-2.7342724E 05	0.
392.12	-1.550550E 04	-0.	1.8830938E 03	0.	-2.0110937E 05	0.
392.12	-1.550550E 04	-0.	1.8830938E 03	0.	-1.4733687E 05	0.
407.00	-1.5583363E 04	-0.	1.7277147E 03	0.	-1.4733687E 05	0.
419.00	-1.5663115E 04	-0.	1.5653267E 03	0.	-1.1994205E 05	0.
429.23	-1.5714127E 04	-0.	1.4555553E 03	0.	-9.8871249E 04	0.
429.23	-1.5714127E 04	-0.	5.6952635E 03	0.	-8.2867140E 04	0.
446.55	-1.5760964E 04	-0.	5.5773908E 03	0.	-8.2867140E 04	0.
455.22	-1.5778082E 04	-0.	5.5254666E 03	0.	1.4724859E 04	0.
455.22	-1.5943273E 04	-0.	2.6779010E 02	0.	6.2901453E 04	0.
470.80	-1.5980314E 04	-0.	1.6803802E 02	0.	6.6161062E 04	0.
486.39	-1.6013901E 04	-0.	7.3150207E 01	0.	6.8066328E 04	0.
486.39	2.8794189E 01	-0.	8.5503570E 01	0.	-1.0446719E 02	0.
500.00	1.1068603E 01	-0.	3.3848388E 01	0.	-3.4589062E 02	0.
520.00	1.0986328E -03	-0.	-1.8310547E -03	0.	-7.0312500E -01	0.

Table 4.79 Fuselage Loading Flight Parachute Conditions

4.5.6 Unit Loading Conditions

The 24 sets of curves of this section are presented to show the distribution of fuselage internal loading for various unit loading conditions including inertia, airloads, and landing loads. The appropriate combinations of these unit distributions resulted in the design fuselage loads for the XV-5A. The fuselage loads for future, and as yet undefined, loading conditions may readily be defined from these curves.

The curves of Figures 4.43 through 4.46 depict fuselage unreacted shears and moments from external airloads. The curves of Figures 4.47 through 4.51 show unreacted shears and moments from unit linear and angular accelerations. Unit values of thrust and ram drag are considered to produce the unreacted fuselage loading of Figures 4.52 and 4.53.

The remaining figures depict fuselage loading from unit loading conditions which are reacted by inertia. Figures 4.54 and 4.55 show, respectively, reacted fuselage loading for a unit vertical load at the forward and aft wing spar locations. The fuselage loading due to unit loads applied to the nose gear is shown in Figures 4.56 through 4.58.

Unit loads or moments applied to each main gear produce the reacted loading curves of Figures 4.59 through 4.61, and unit loads and moments applied only at the left-main-gear result in the reacted shear and moment curves of Figures 4.62 through 4.66.

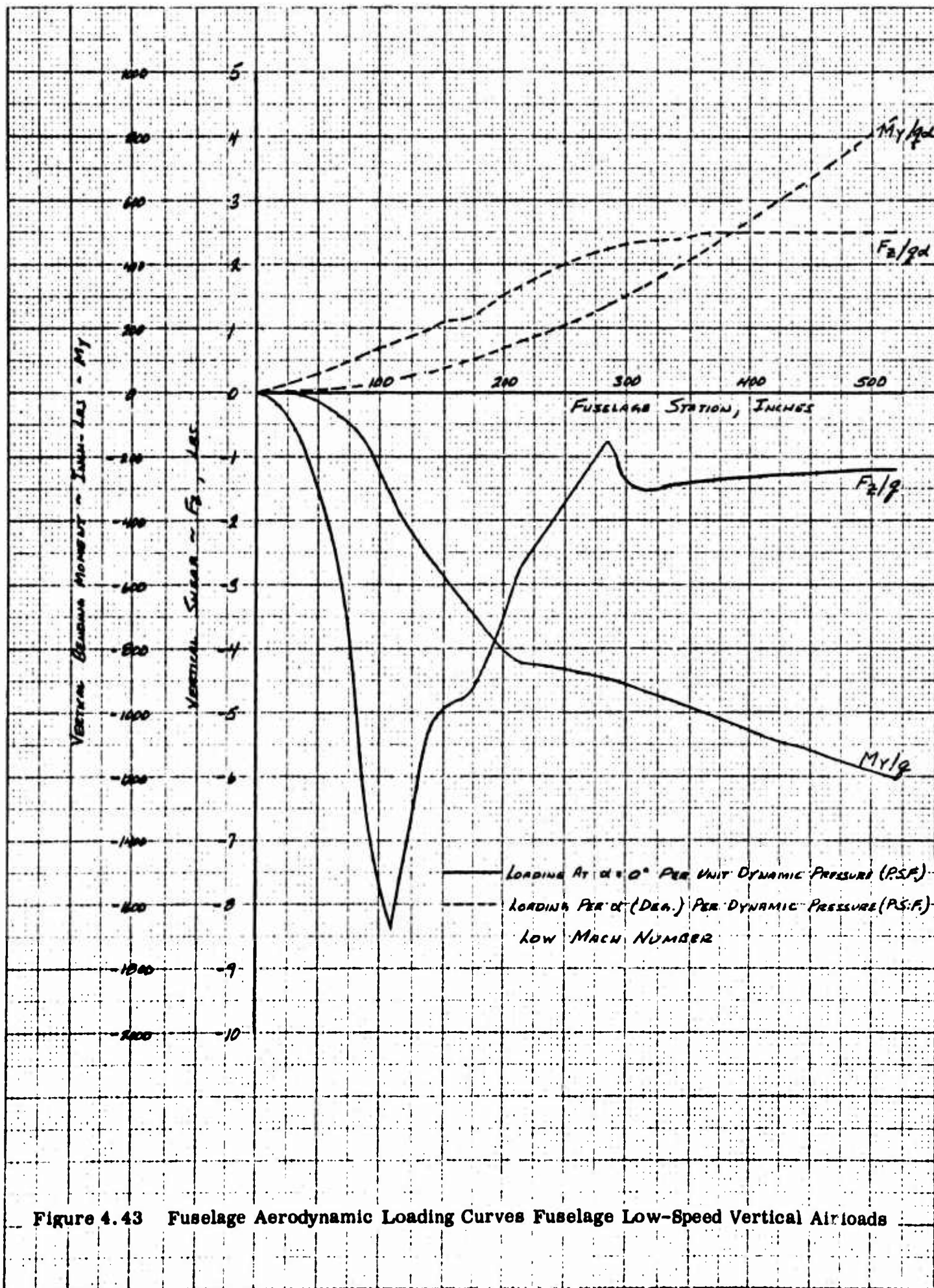

Figure 4.43 Fuselage Aerodynamic Loading Curves Fuselage Low-Speed Vertical Airloads

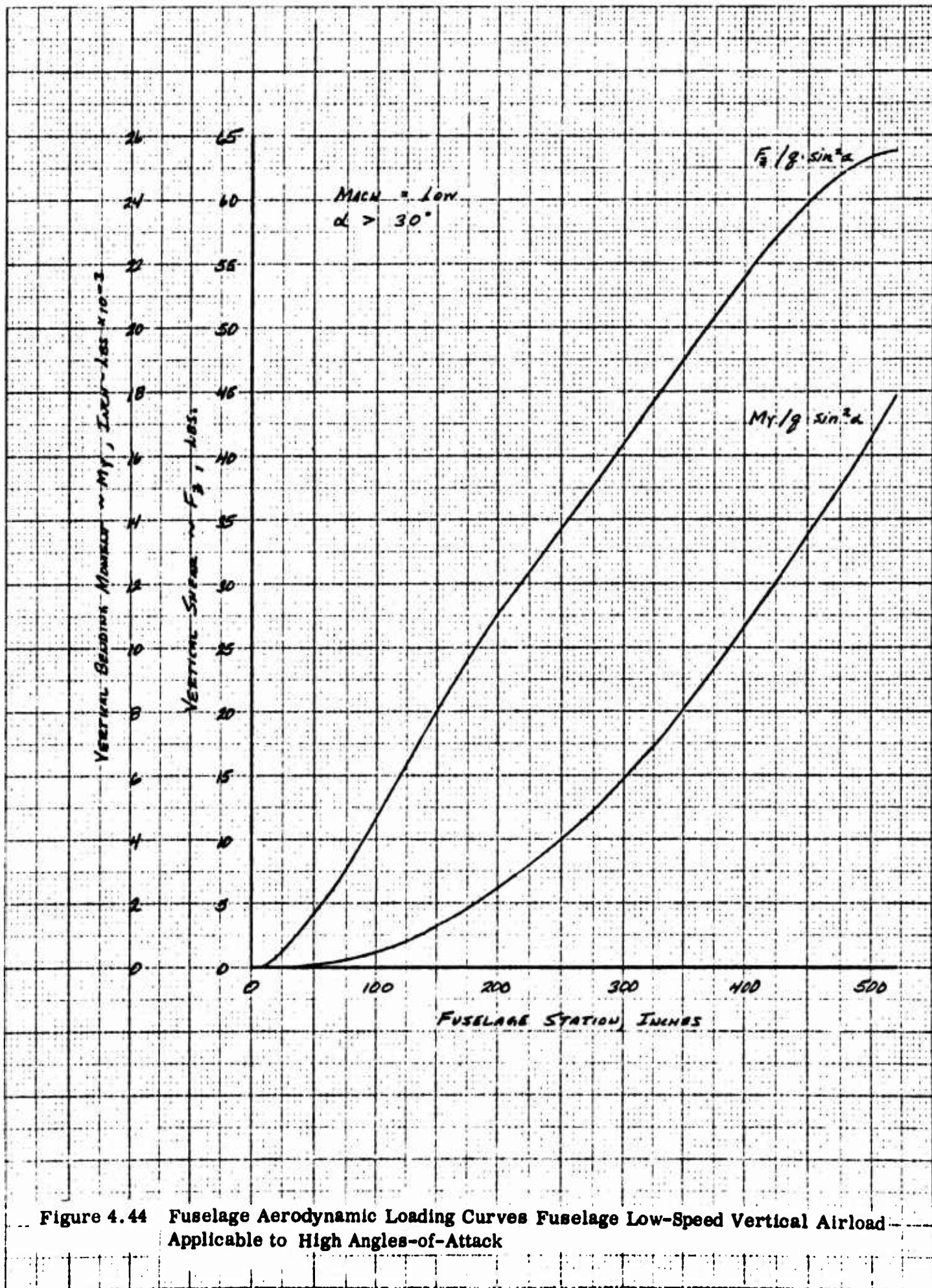

Figure 4.44 Fuselage Aerodynamic Loading Curves Fuselage Low-Speed Vertical Airload Applicable to High Angles-of-Attack

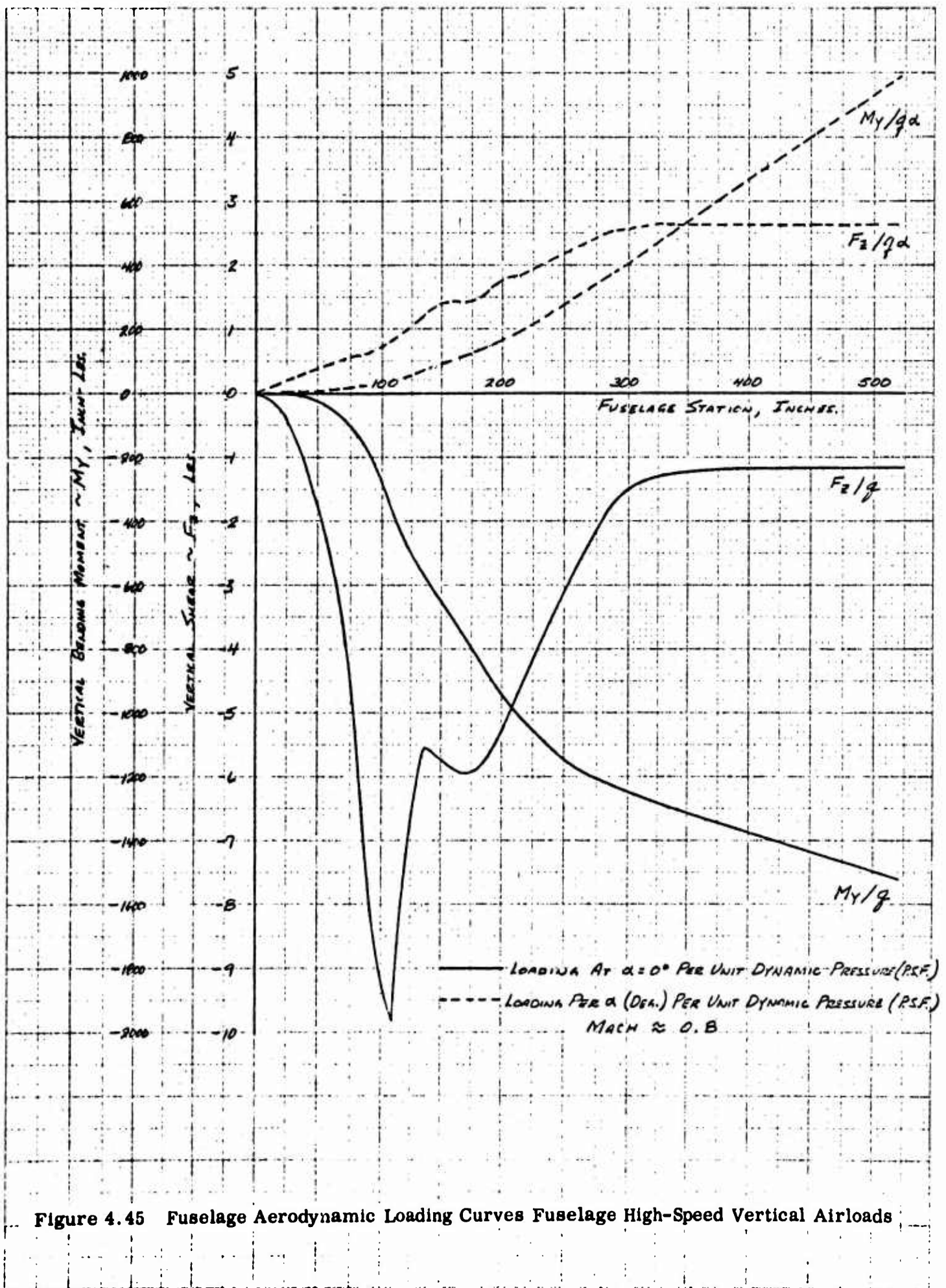

Figure 4.45 Fuselage Aerodynamic Loading Curves Fuselage High-Speed Vertical Airloads

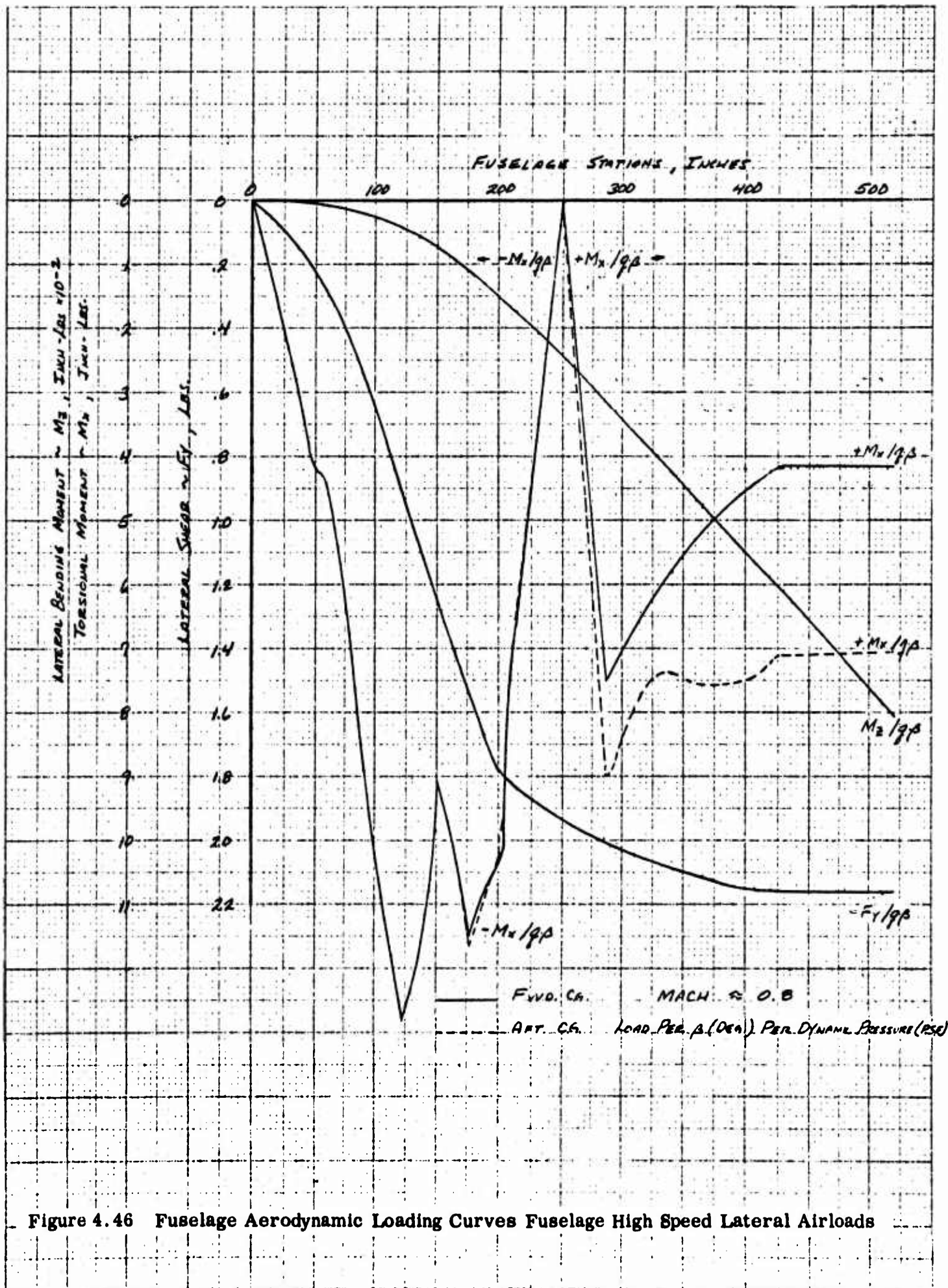

Figure 4.46 Fuselage Aerodynamic Loading Curves Fuselage High Speed Lateral Airloads



Figure 4.47 Fuselage Aerodynamic Loading Curves Unit Vertical Load Factor

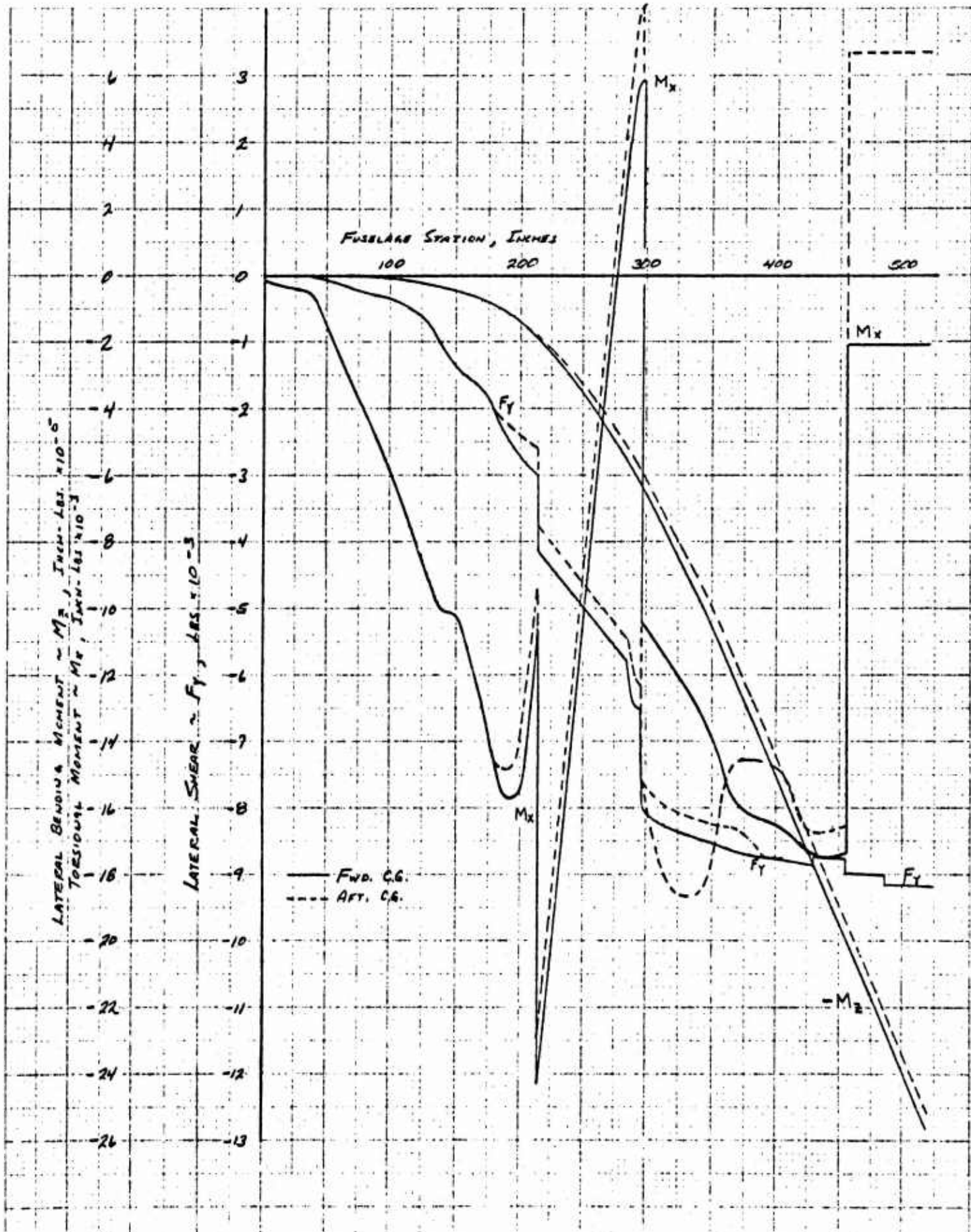

Figure 4.48 Fuselage Aerodynamic Loading Curves Unit Lateral Load Factor

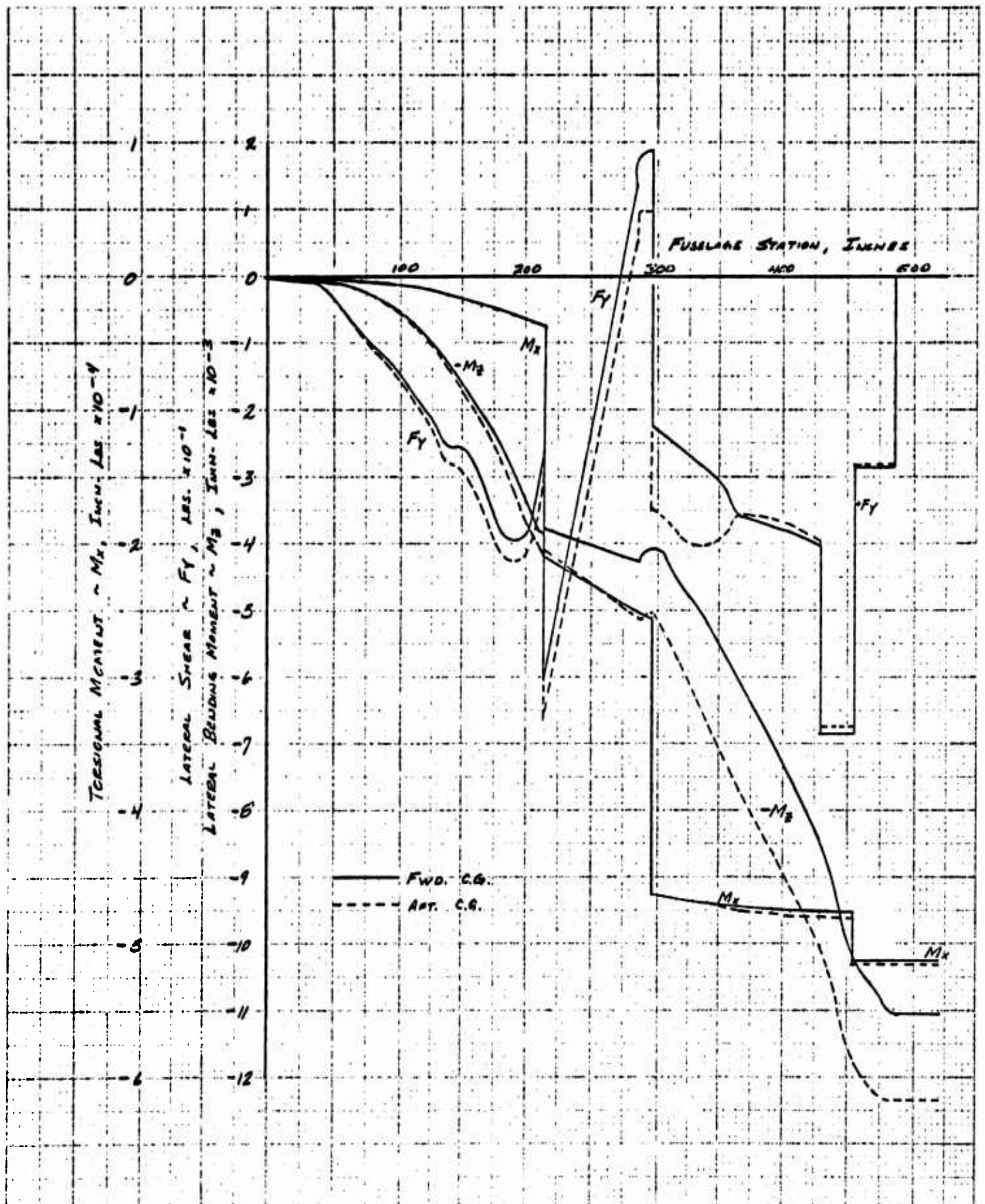

Figure 4.49 Fuselage Inertial Loading Curves One-Radian-Per-Second Rolling Acceleration

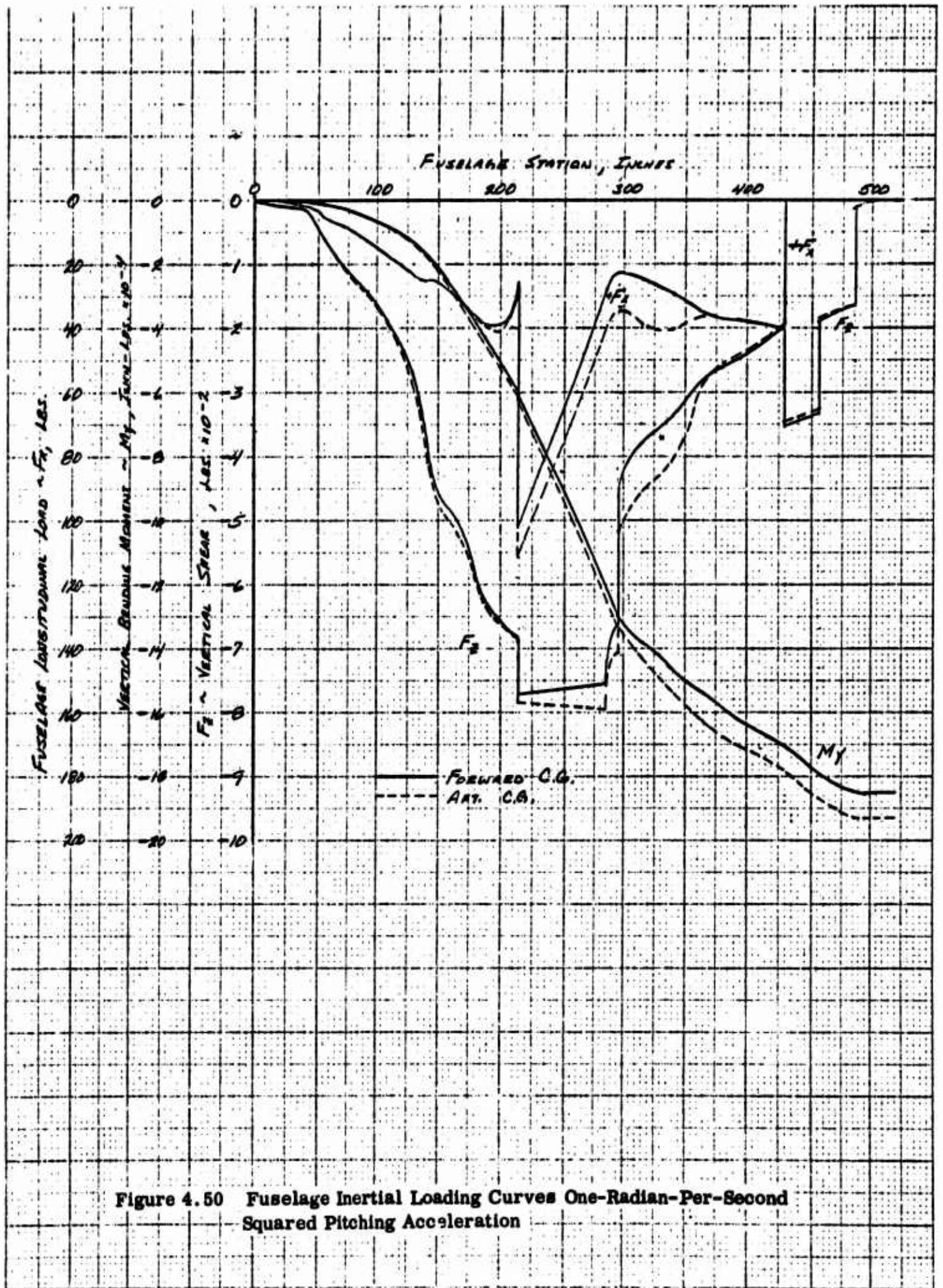

Figure 4.50 Fuselage Inertial Loading Curves One-Radian-Per-Second Squared Pitching Acceleration

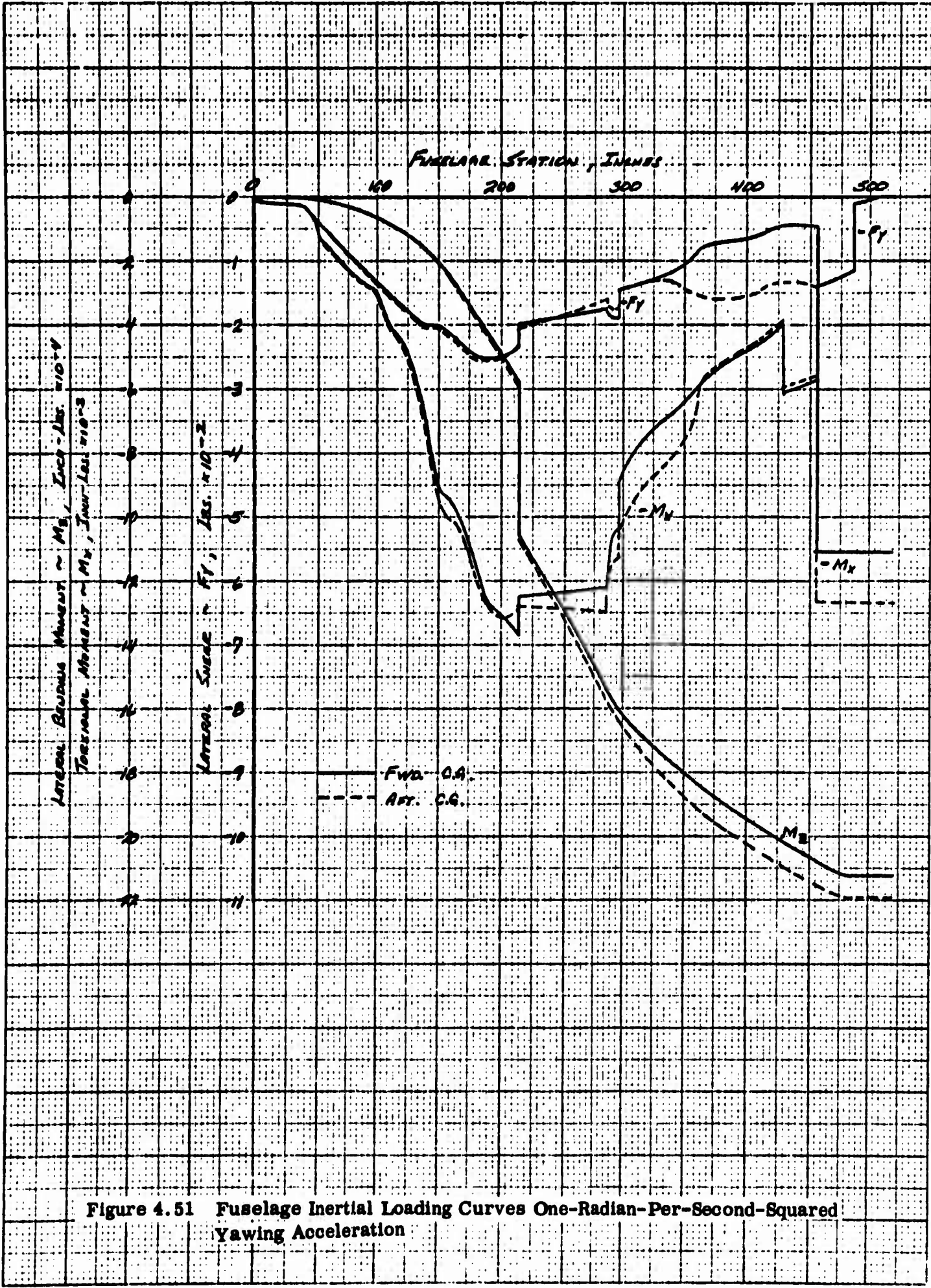

Figure 4.51 Fuselage Inertial Loading Curves One-Radian-Per-Second-Squared Yawing Acceleration

VERTICAL BENDING MOMENT ~ M_f , INCH- $\times 10^{-3}$

VERTICAL FORCE ~ F_z , LBS. $\times 10^3$

LONGITUDINAL FORCE ~ F_x , LBS. $\times 10^3$

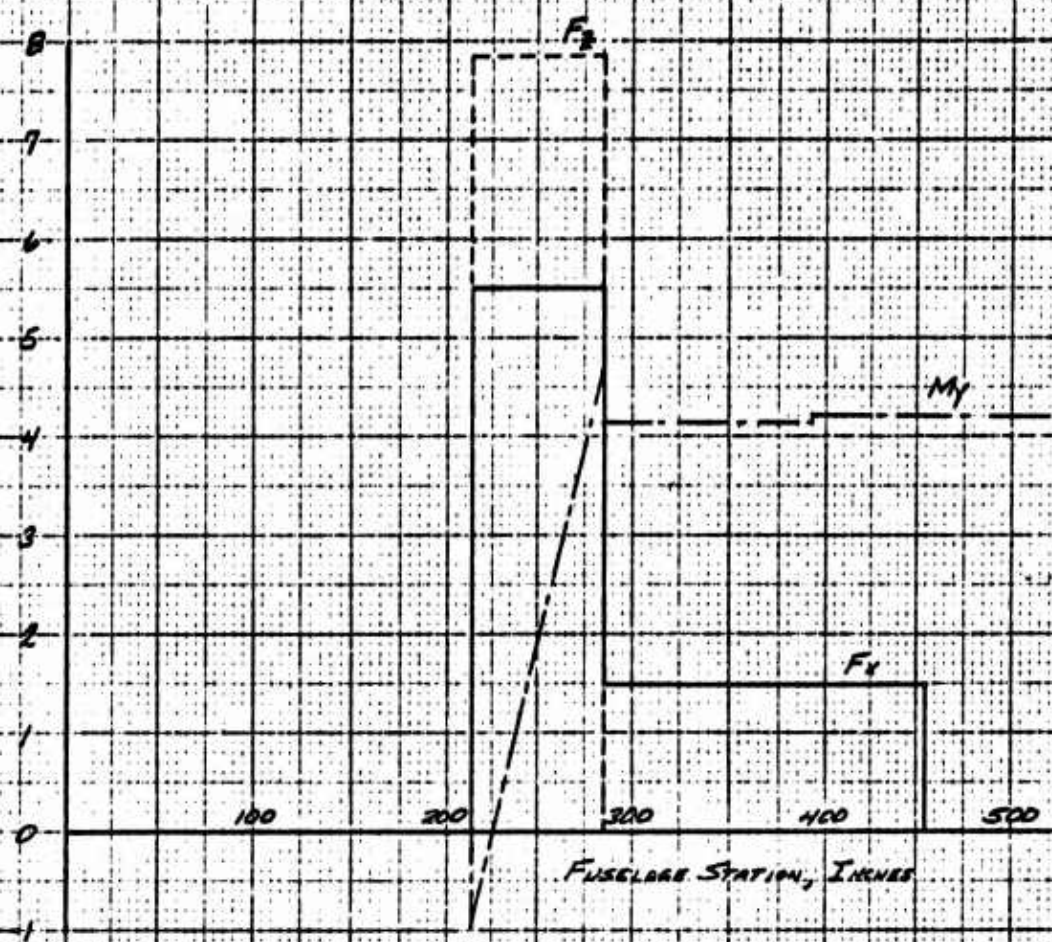

Figure 4.52 Fuselage Aerodynamic Loading Curves Unit Ram-Drag Condition

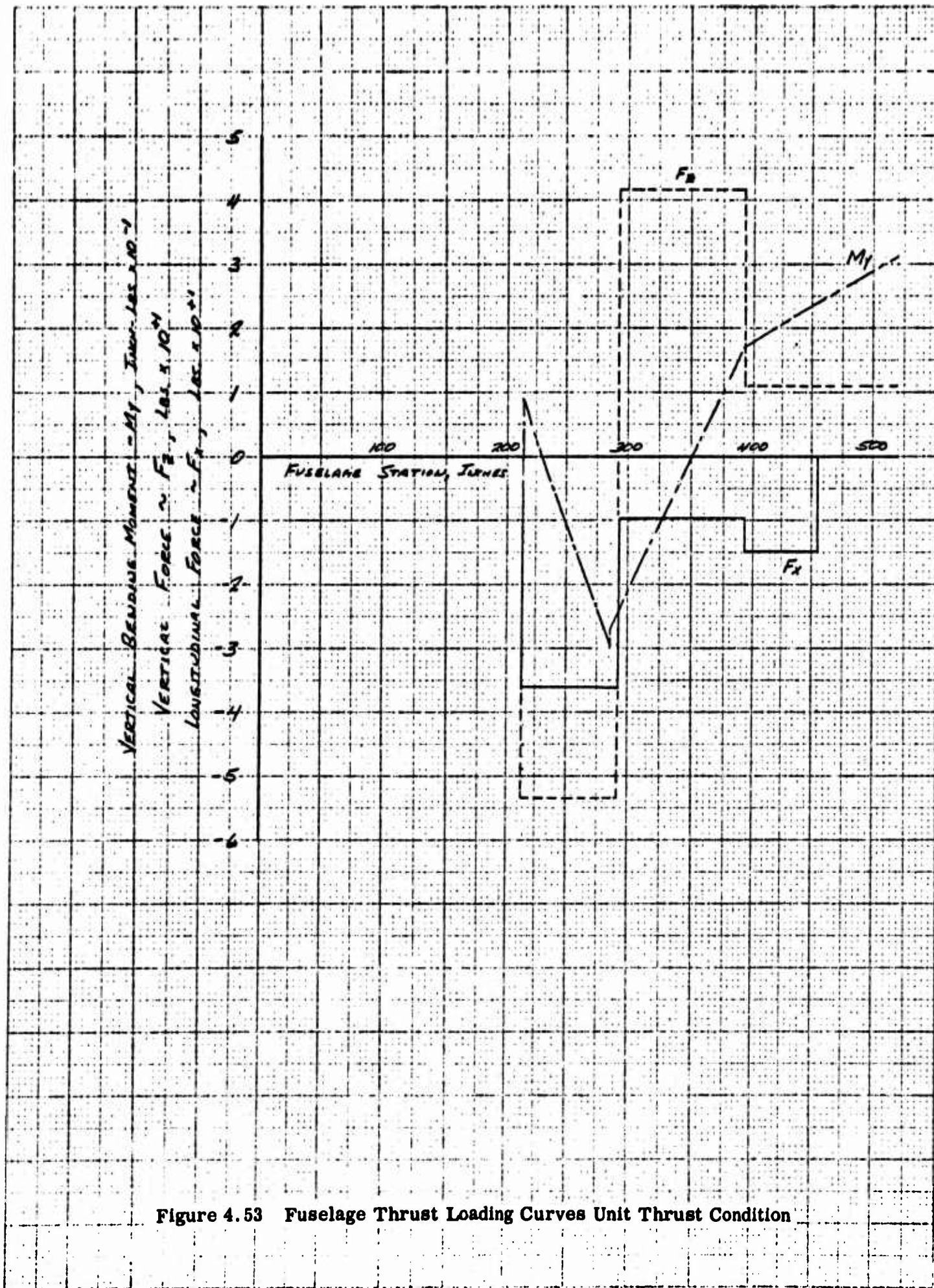

Figure 4.53 Fuselage Thrust Loading Curves Unit Thrust Condition

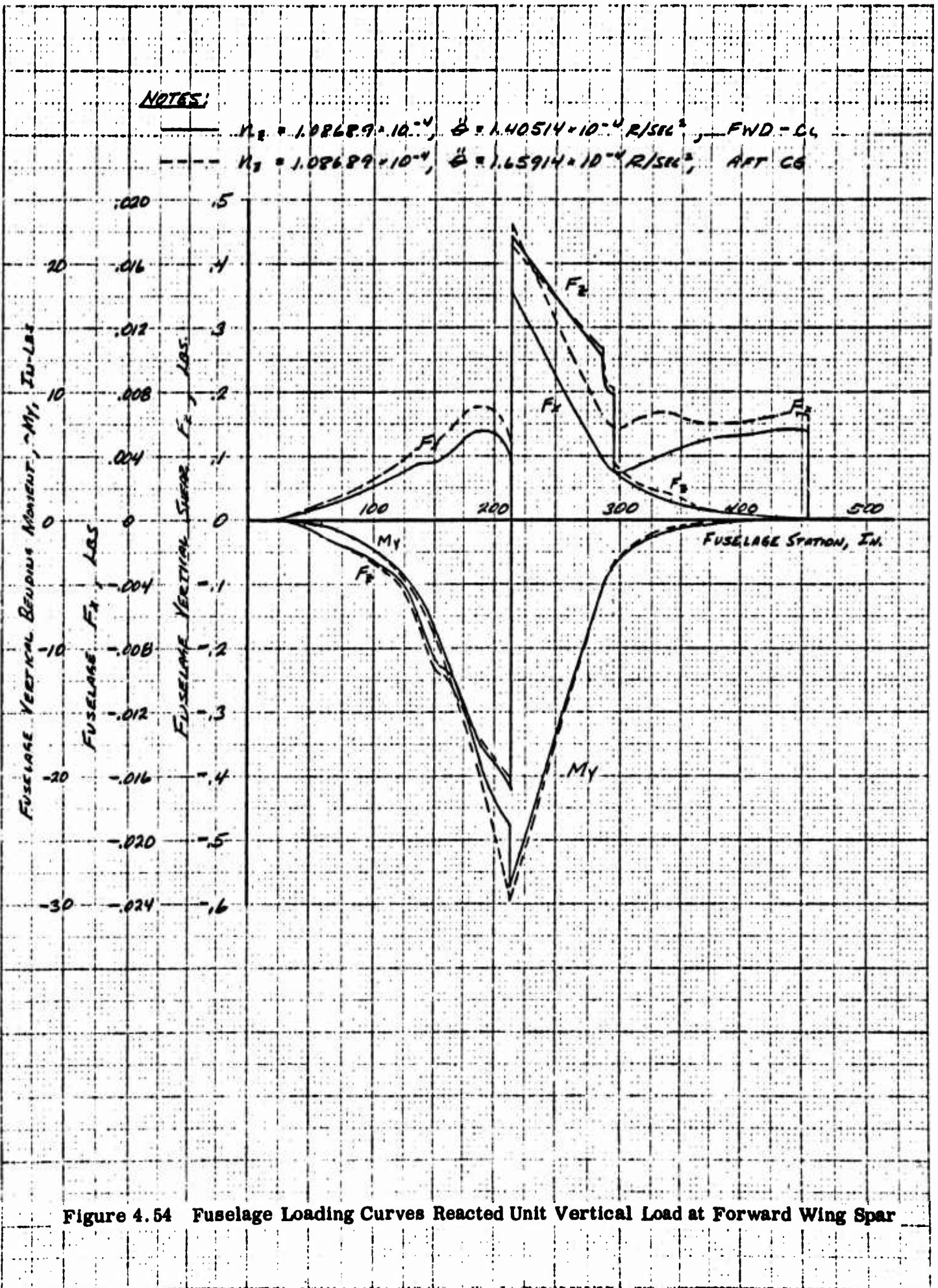
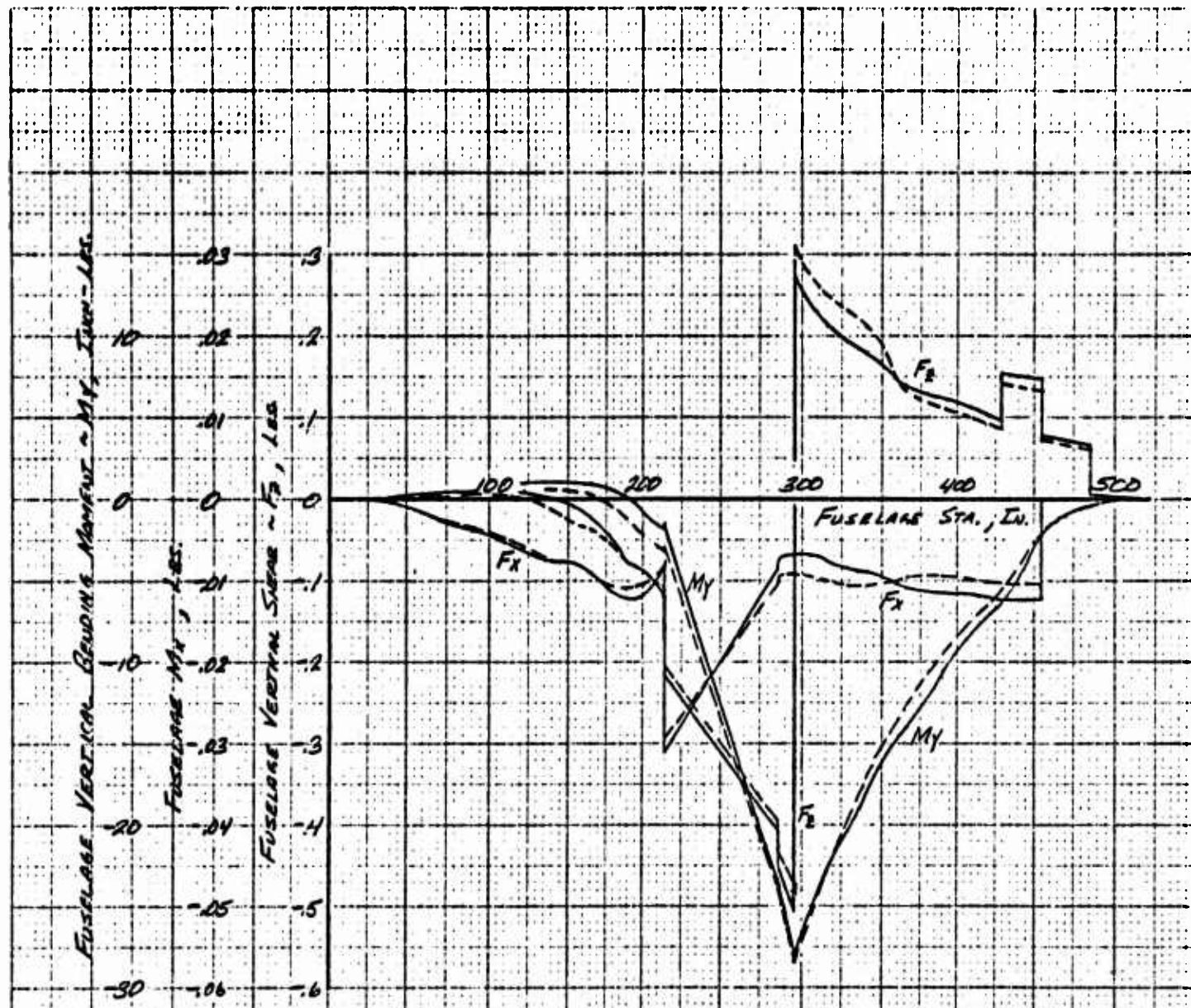

Figure 4.54 Fuselage Loading Curves Reacted Unit Vertical Load at Forward Wing Spar



NOTES:

- FWD. C.G., $n_z = 1.08689 \times 10^{-4}$, $\ddot{\theta} = -2.05299 \times 10^{-4} \text{ R/SEC}^2$
- - - AFT. C.G., $n_z = 1.08689 \times 10^{-4}$, $\ddot{\theta} = -2.61796 \times 10^{-4} \text{ R/SEC}^2$

Figure 4.55 Fuselage Loading Curves Reacted Unit Vertical Load at Aft Wing Spar

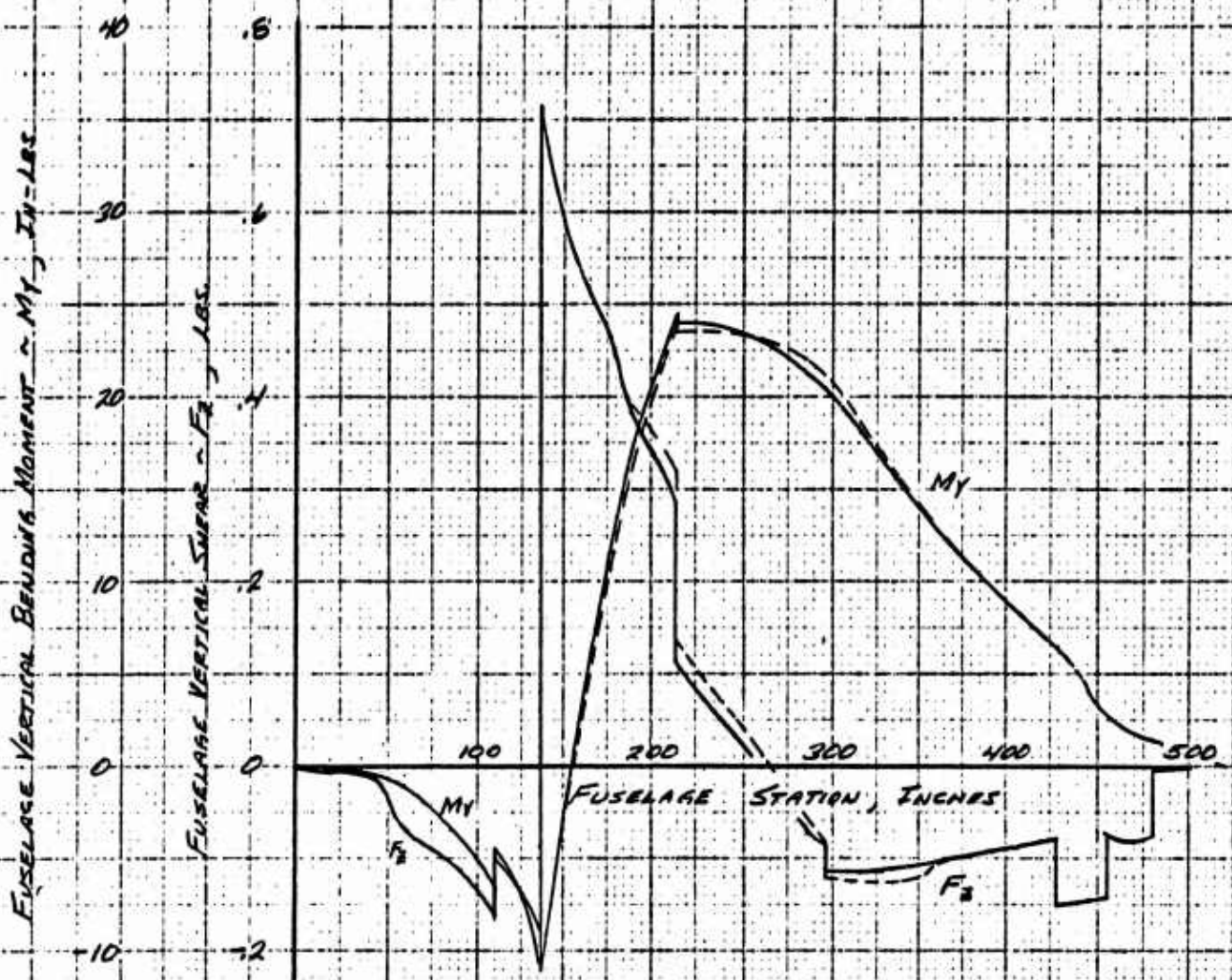

NOTES:

— FWD. CG, $M_z = -1.08689 \times 10^{-4}$, $\ddot{\theta} = 5.657 \times 10^{-4}$
 - - - AFT. CG, $M_z = -1.08689 \times 10^{-4}$, $\ddot{\theta} = 5.7386 \times 10^{-4}$
 NOSE GEAR LOADS APPLIED TO WHEEL AXIS (F.S. 125.312, W.L. 37.2)

Figure 4.56 Fuselage Loading Curves Reacted Unit Vertical Load On Nose Gear

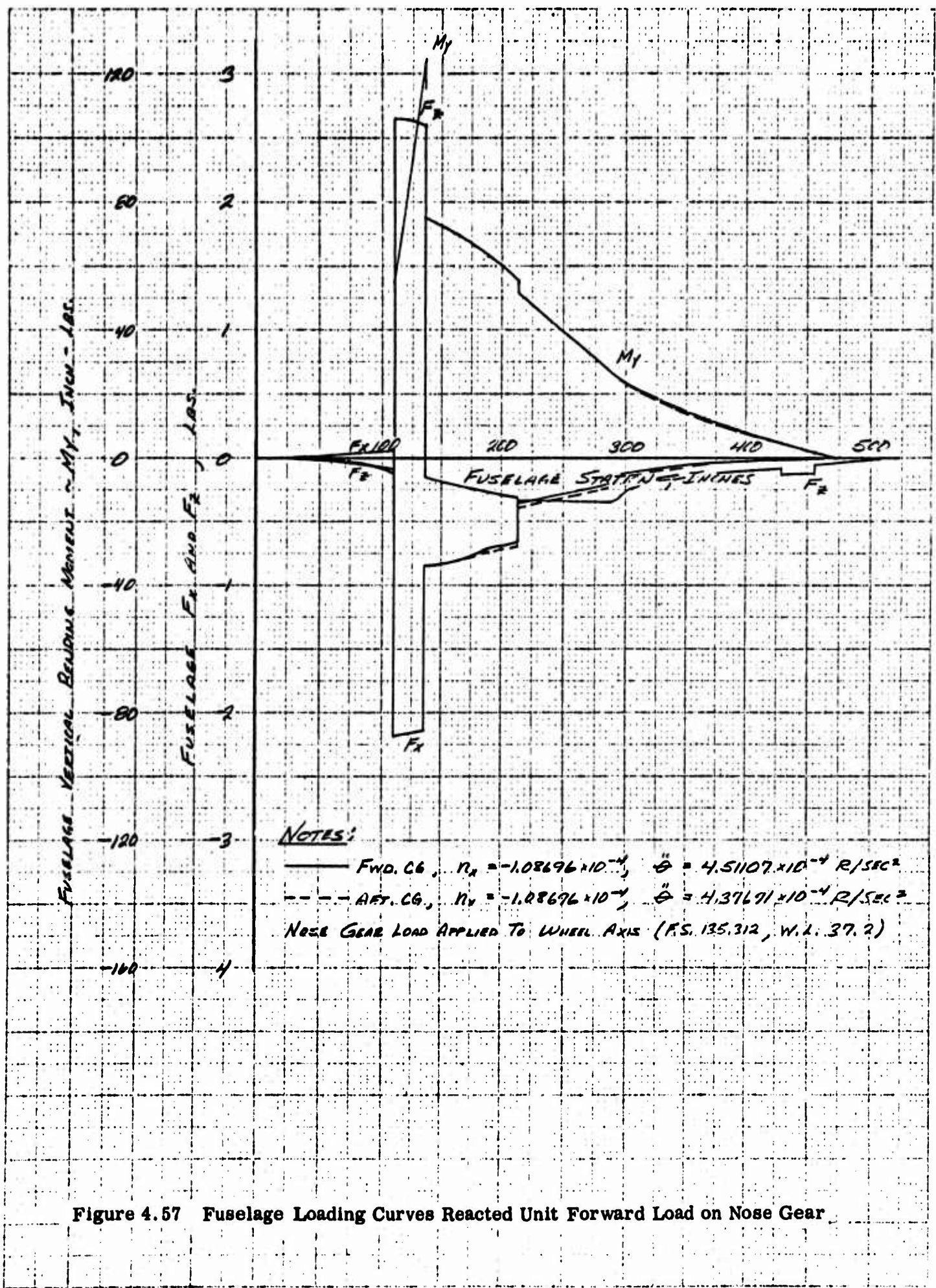
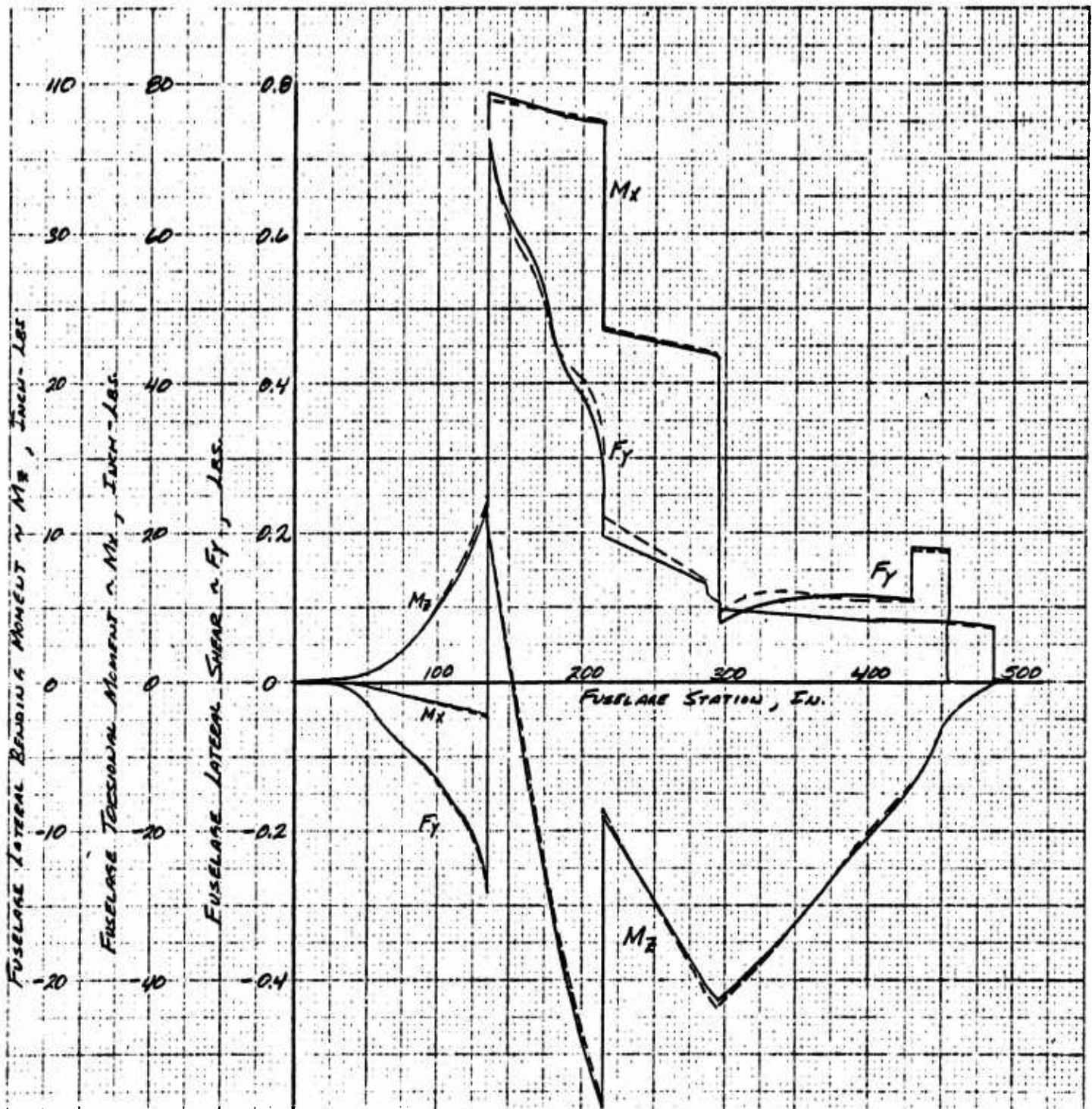

Figure 4.57 Fuselage Loading Curves Reacted Unit Forward Load on Nose Gear



NOTES:
 — FWD CG, $M_Y = 1.08696 \times 10^{-4}$, $\phi = 1.53725 \times 10^{-3}$, $\gamma = -4.12857 \times 10^{-4}$
 - - - AFT CG, $M_Y = 1.08696 \times 10^{-4}$, $\phi = 1.53224 \times 10^{-3}$, $\gamma = -4.15287 \times 10^{-4}$

Figure 4.58 Fuselage Loading Curves Reacted Unit Side Load on Nose Gear

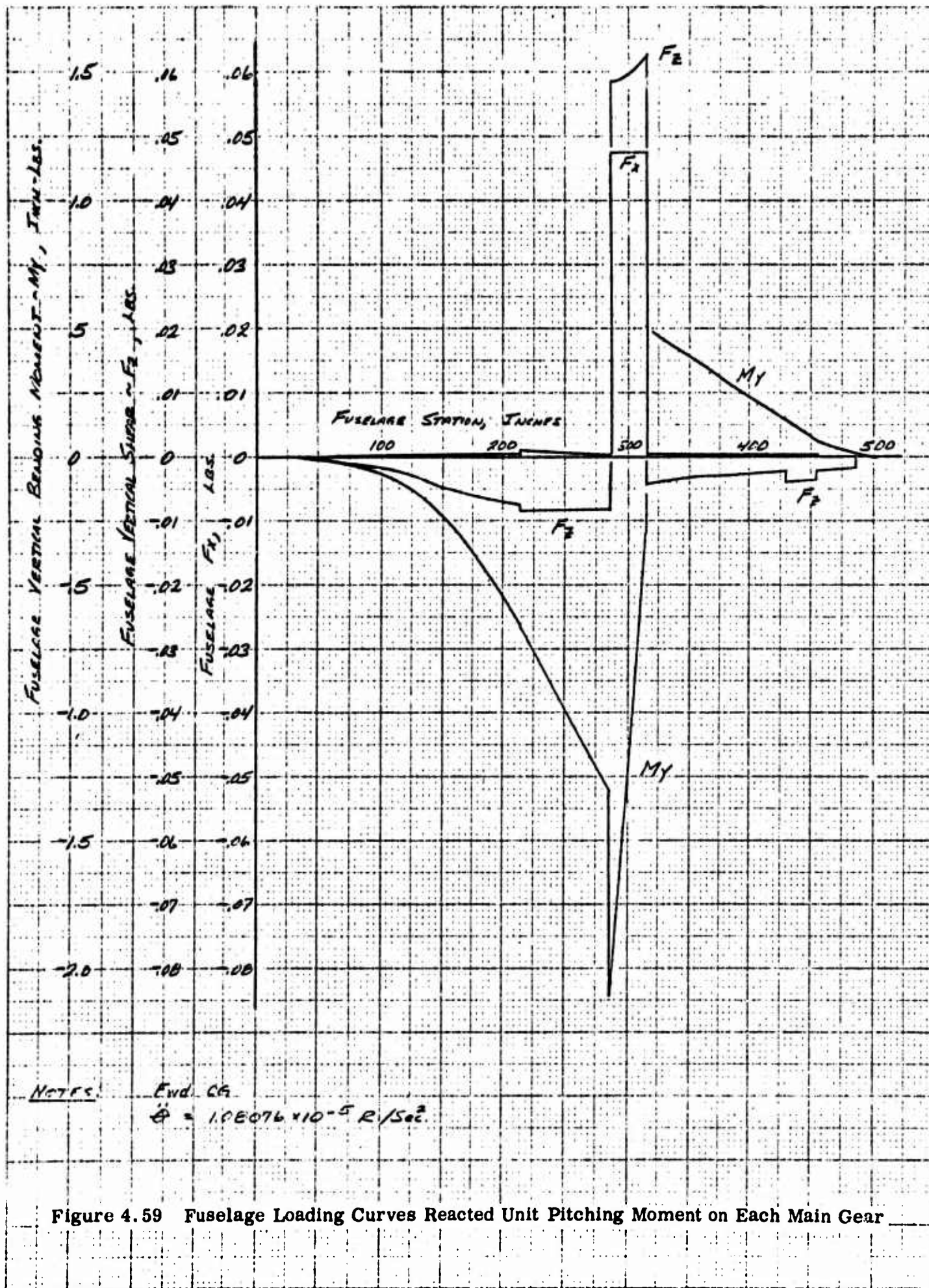

Figure 4.59 Fuselage Loading Curves Reacted Unit Pitching Moment on Each Main Gear

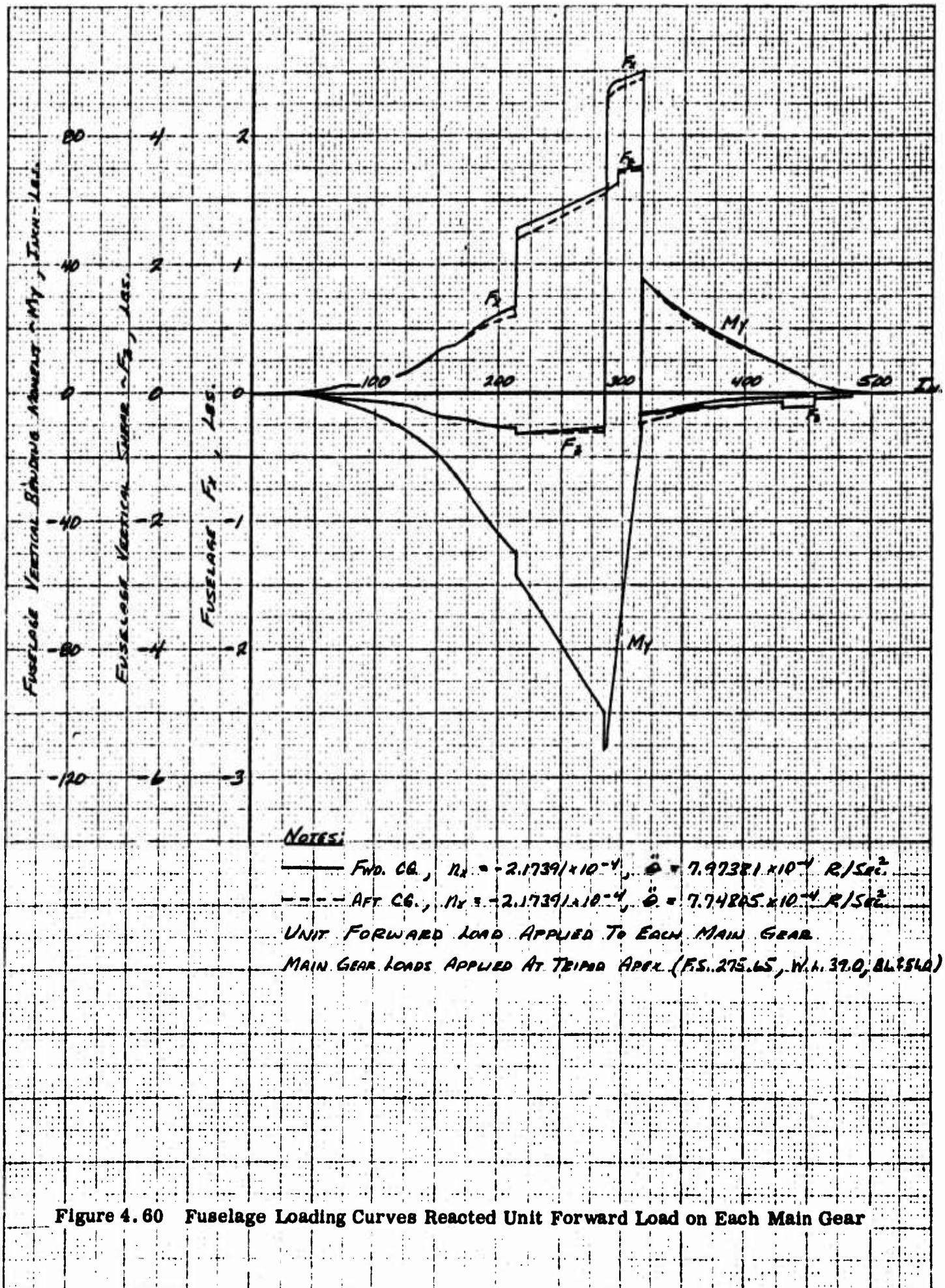
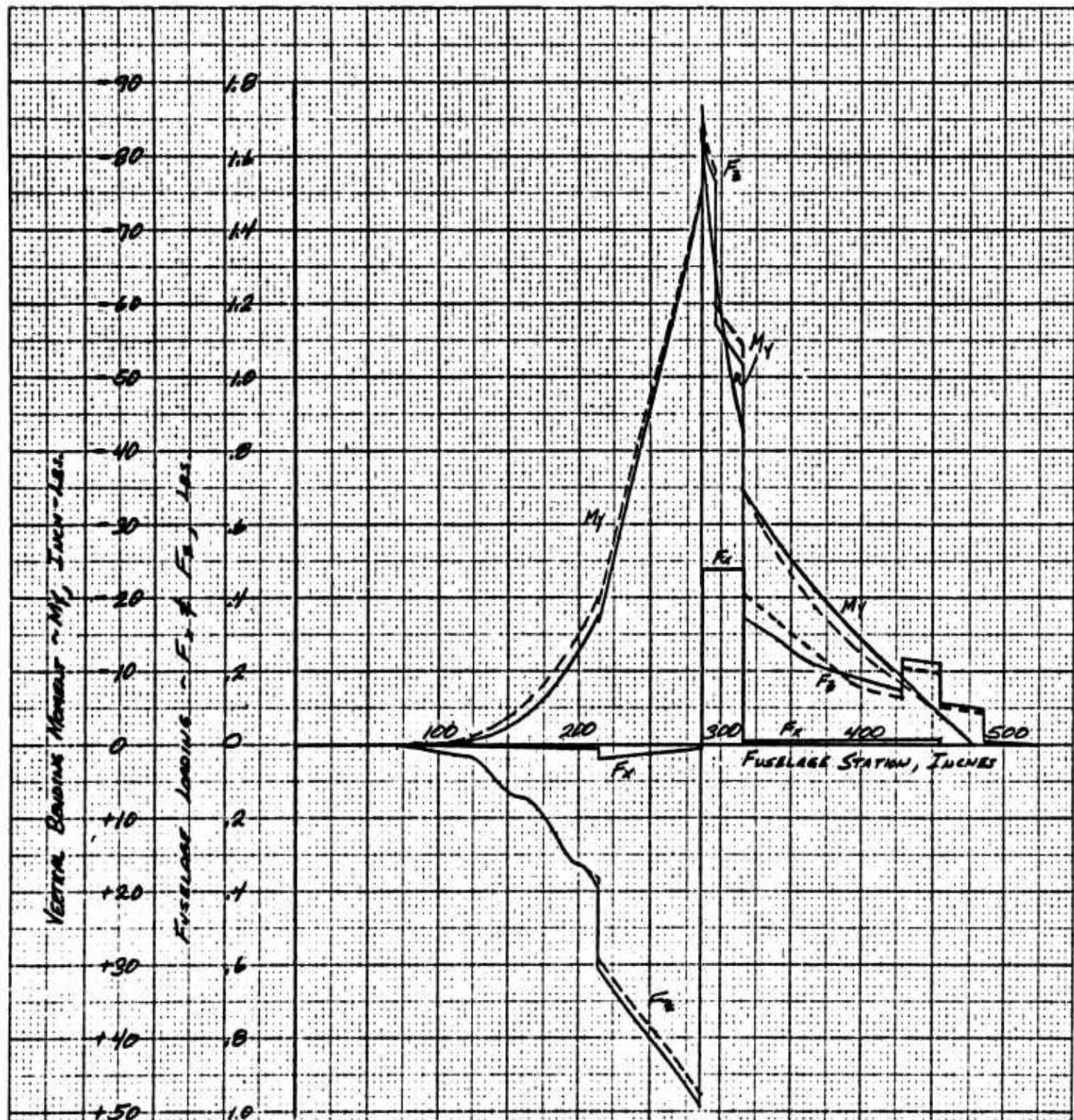

Figure 4.60 Fuselage Loading Curves Reacted Unit Forward Load on Each Main Gear



NOTES:

- FWD. CG, $M_z = 2.17378 \times 10^{-4}$, $\ddot{\theta} = -3.85260 \times 10^{-4}$ R/SEC.
- - - AFT. CG, $M_z = 2.17378 \times 10^{-4}$, $\ddot{\theta} = -3.07404 \times 10^{-4}$ R/SEC.
- UNIT VERTICAL LOAD APPLIED TO EACH MAIN GEAR
- MAIN GEAR LOAD APPLIED AT TRIPOD APEX (F.S. 275.65; W.L. 39.0; E.L. ±51.0)

Figure 4.61 Fuselage Loading Curves Reacted Unit Vertical Load on Each Main Gear

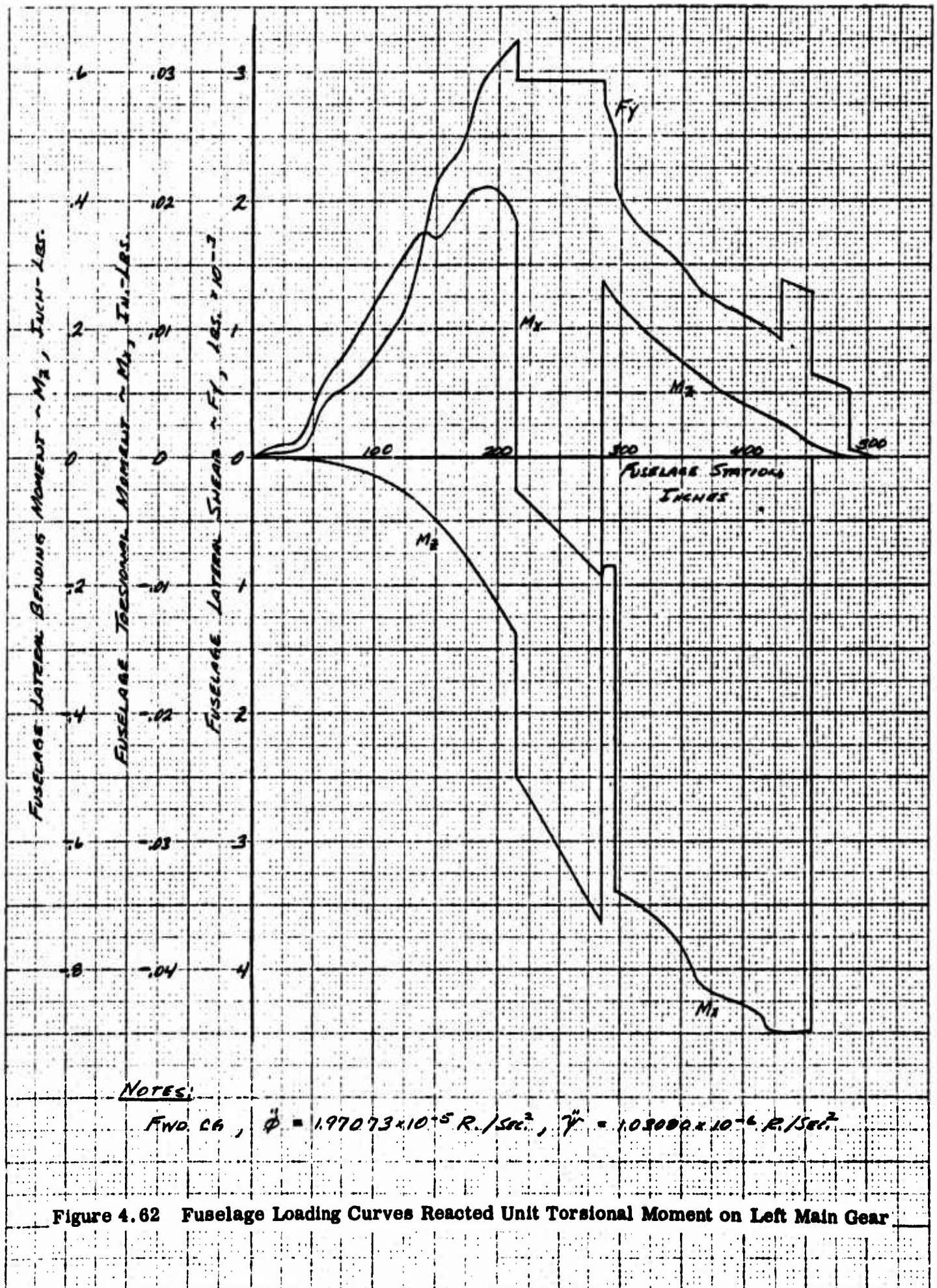
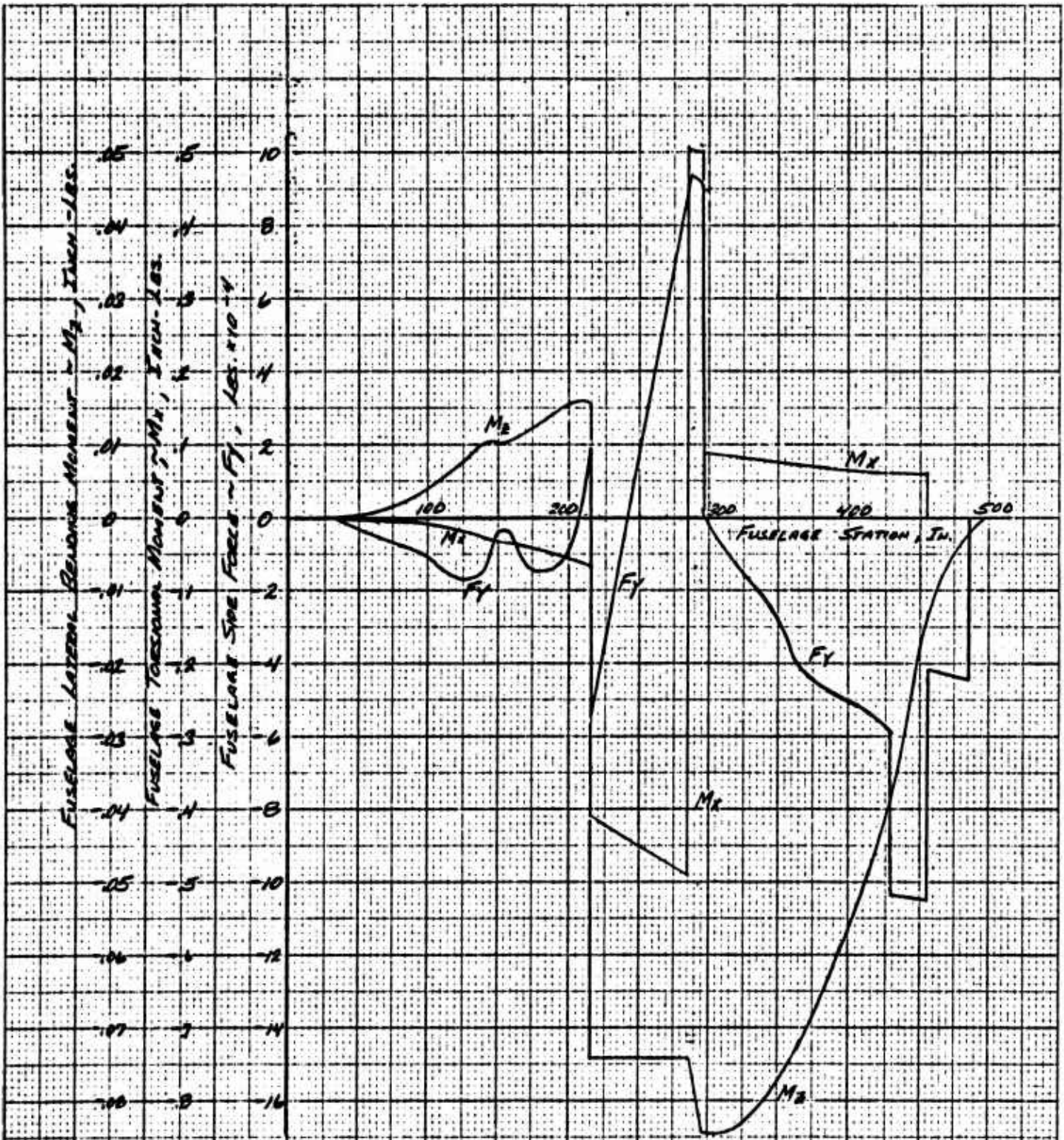

Figure 4.62 Fuselage Loading Curves Reacted Unit Torsional Moment on Left Main Gear



NOTES:

FORWARD CA, $\ddot{\phi} = 1.03080 \times 10^{-6} \text{ R/SEC}^2$, $\ddot{\gamma} = 4.76553 \times 10^{-6} \text{ R/SEC}^2$

Figure 4.63 Fuselage Loading Curves Reacted Unit Yawing Moment on Left Main Gear

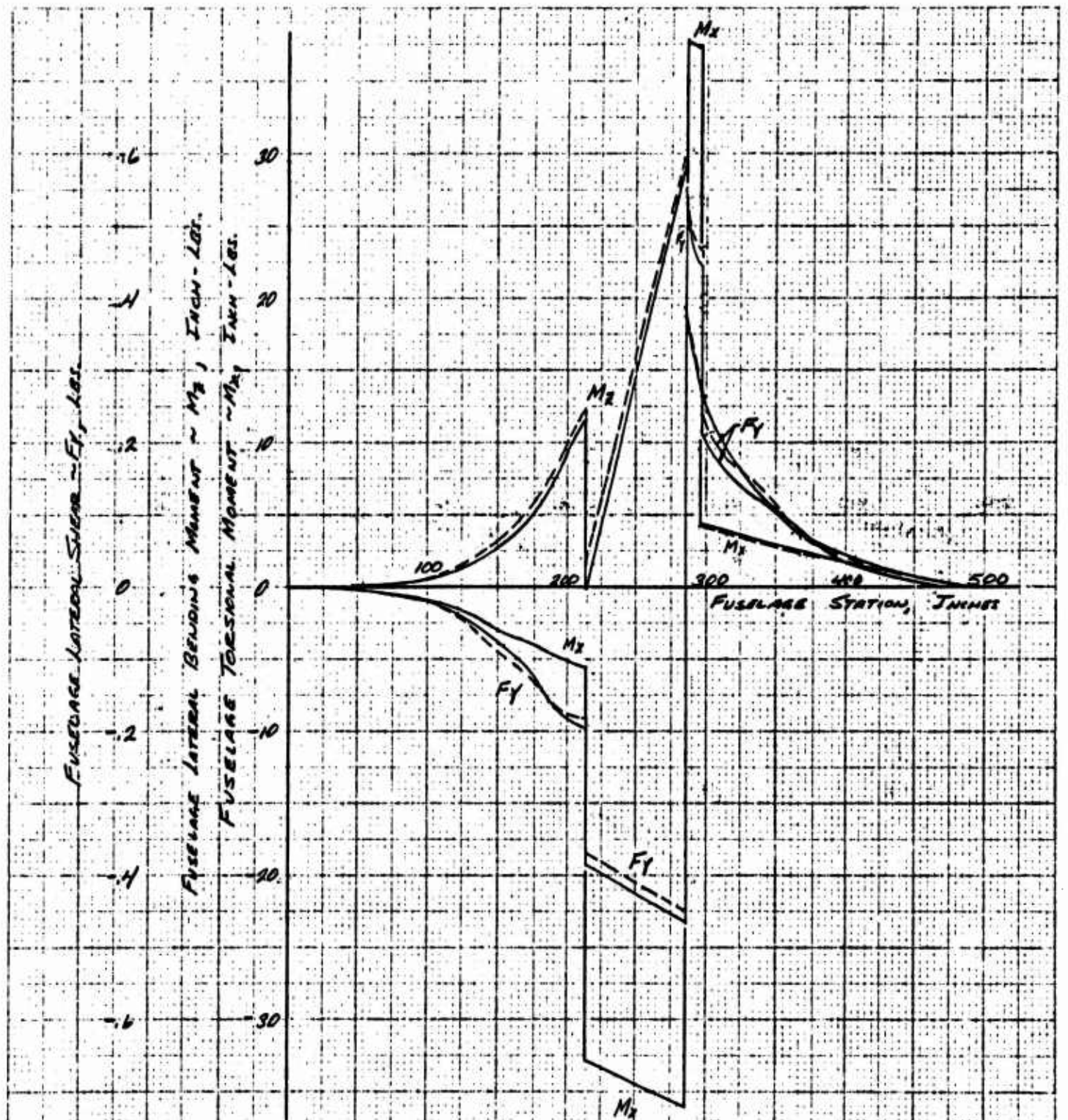

NOTES:

- FWD. CA, $n_y = 1.08696 \times 10^{-4}$, $\ddot{\phi} = 1.49075 \times 10^{-3} \text{ R./SEC}^2$, $\ddot{\psi} = 2.45930 \times 10^{-4} \text{ R./SEC}^2$
- - - AFT. CA, $n_y = 1.08696 \times 10^{-4}$, $\ddot{\phi} = 1.50064 \times 10^{-4} \text{ R./SEC}^2$, $\ddot{\psi} = 2.21407 \times 10^{-4} \text{ R./SEC}^2$

Figure 4.64 Fuselage Loading Curves Reacted Unit Side Load on Left Main Gear

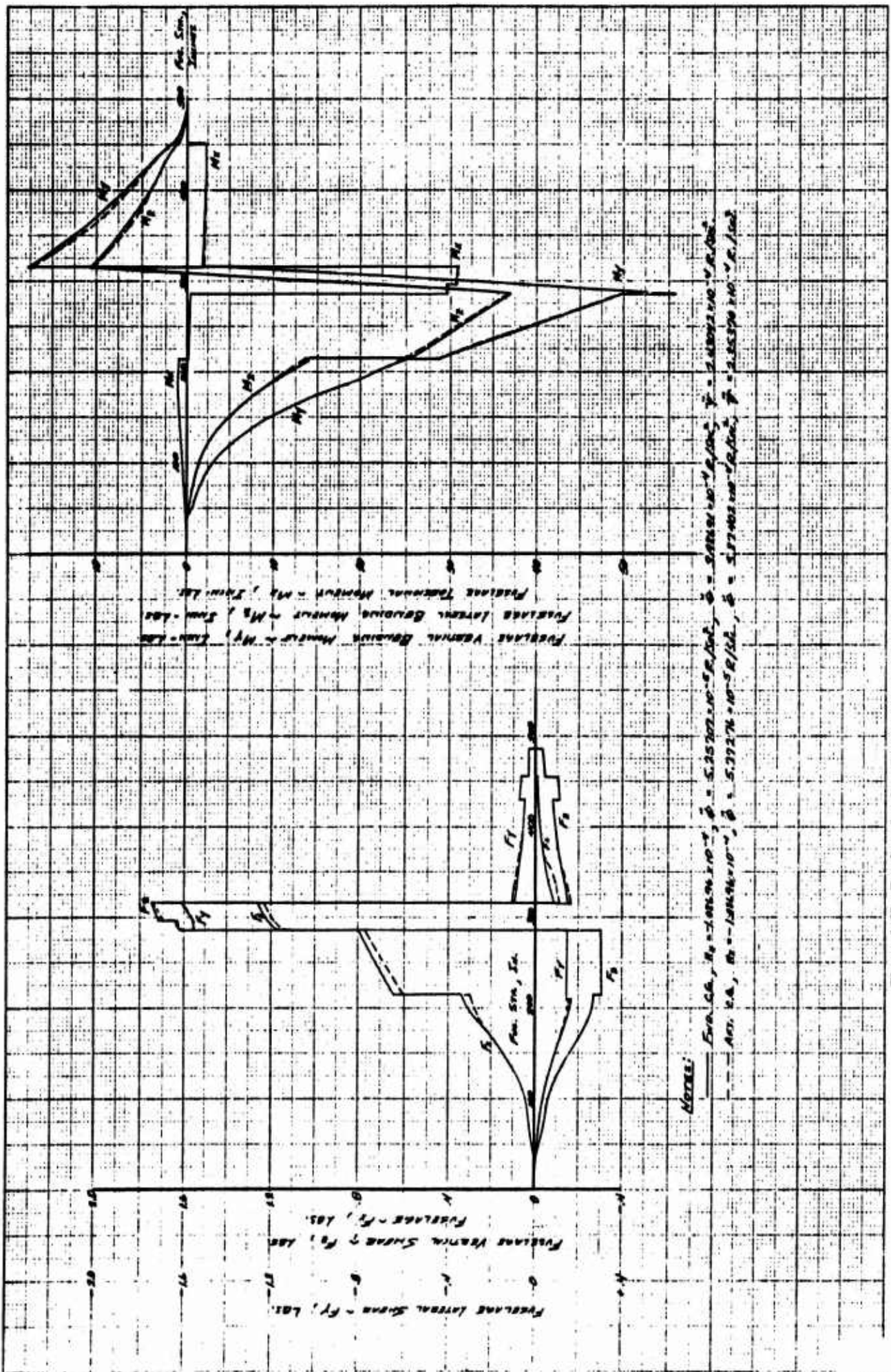

Figure 4.65 Fuselage Loading Curves Reacted Unit Forward Load On Left Main Gear

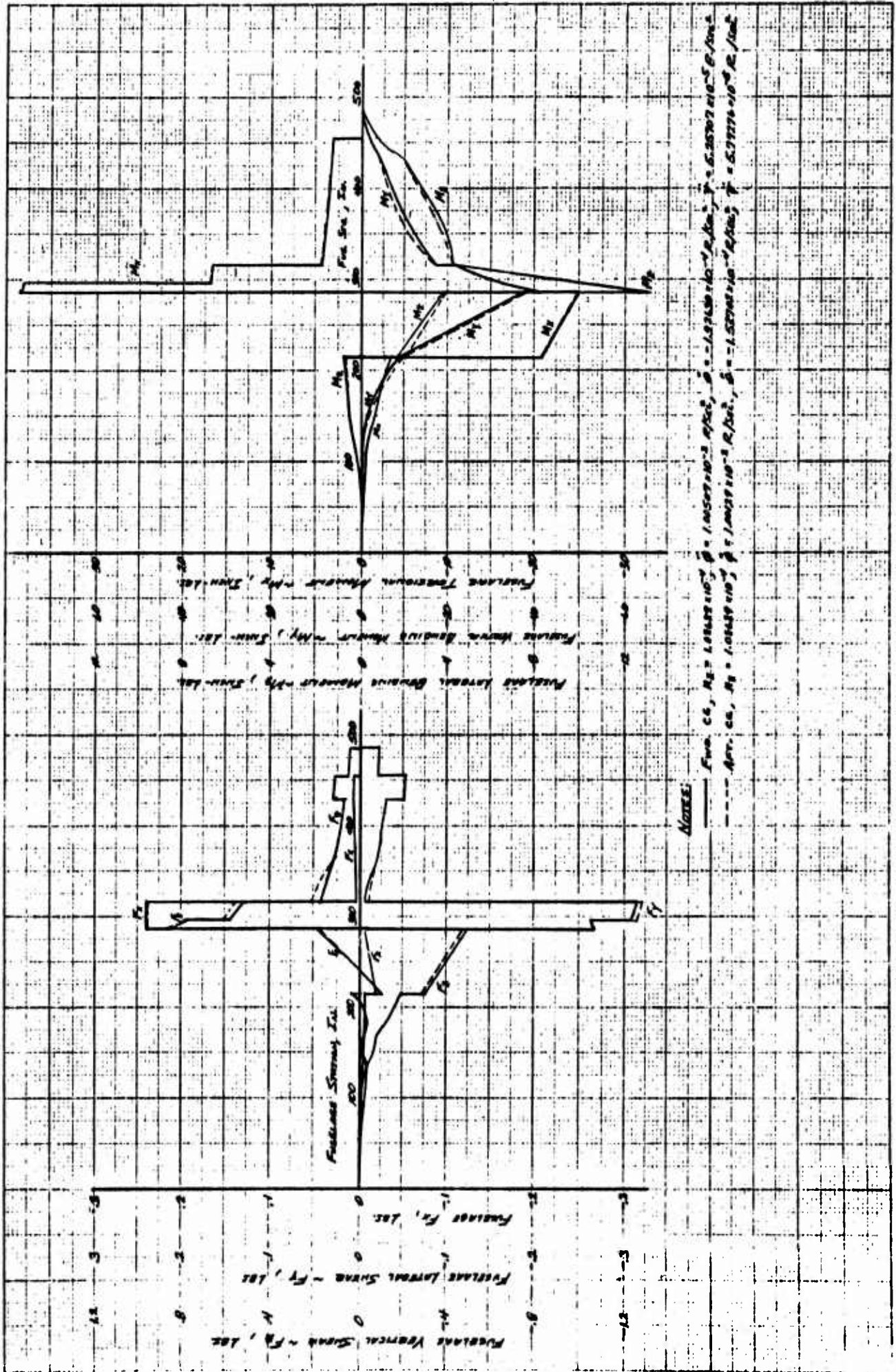

Figure 4.66 Fuselage Loading Curves Reacted Unit Vertical Load On Left Main Gear

4.6 HORIZONTAL TAIL LOADS

As a result of the symmetrical flight maneuver investigation of Section 4.1.1, two particular conditions were found which produced critical loading. Maximum shear and bending occurred for flight condition F-12 whereas maximum torsion occurred for condition F-13 (see Table 4.1). These data were then incorporated with the unit shear, bending and torque curves of Figures 4.67 through 4.69 to define local conditions, and to enable the construction of composite values used in design. The corresponding composite root (center line) conditions, per panel, were as follows:

Horizontal Tail Static Test Loading

Shear, lbs. -----	3,550
Bending Moment, in-lbs. -----	121,050
Torsion (center spar), in-lbs. -----	29,640

Design elevator loads are presented in Section 4.9.

4.7 VERTICAL TAIL LOADS

Similar to the horizontal tail, two flight conditions were found which produced maximum root values of shear, bending and torsion. Maximum shear and bending resulted from a lateral gust (40 ft/sec) condition (LG 3 or 4, Table 4.2) whereas maximum torque occurred from a rudder kick condition (AF 17 or 18). Local spanwise characteristics were obtained by applying these data to the unit shear, bending and torque curves of Figures 4.70 through 4.75.

With reference to the center spar of the vertical tail, root (fuselage juncture) values were as follows:

Vertical Tail Design Loading

Shear, lbs. -----	3,527
Bending Moment (center spar), in-lbs.	177,309
Torsion (center spar), in-lbs. -----	84,828

Design rudder loads are presented in Section 4.9.

Note:

- 1) Mach No. ≈ 0.756
- 2) Positive (+) shear acts "up"
- 3) Ref. axis = F. Sta. 496

Shear, lbs.

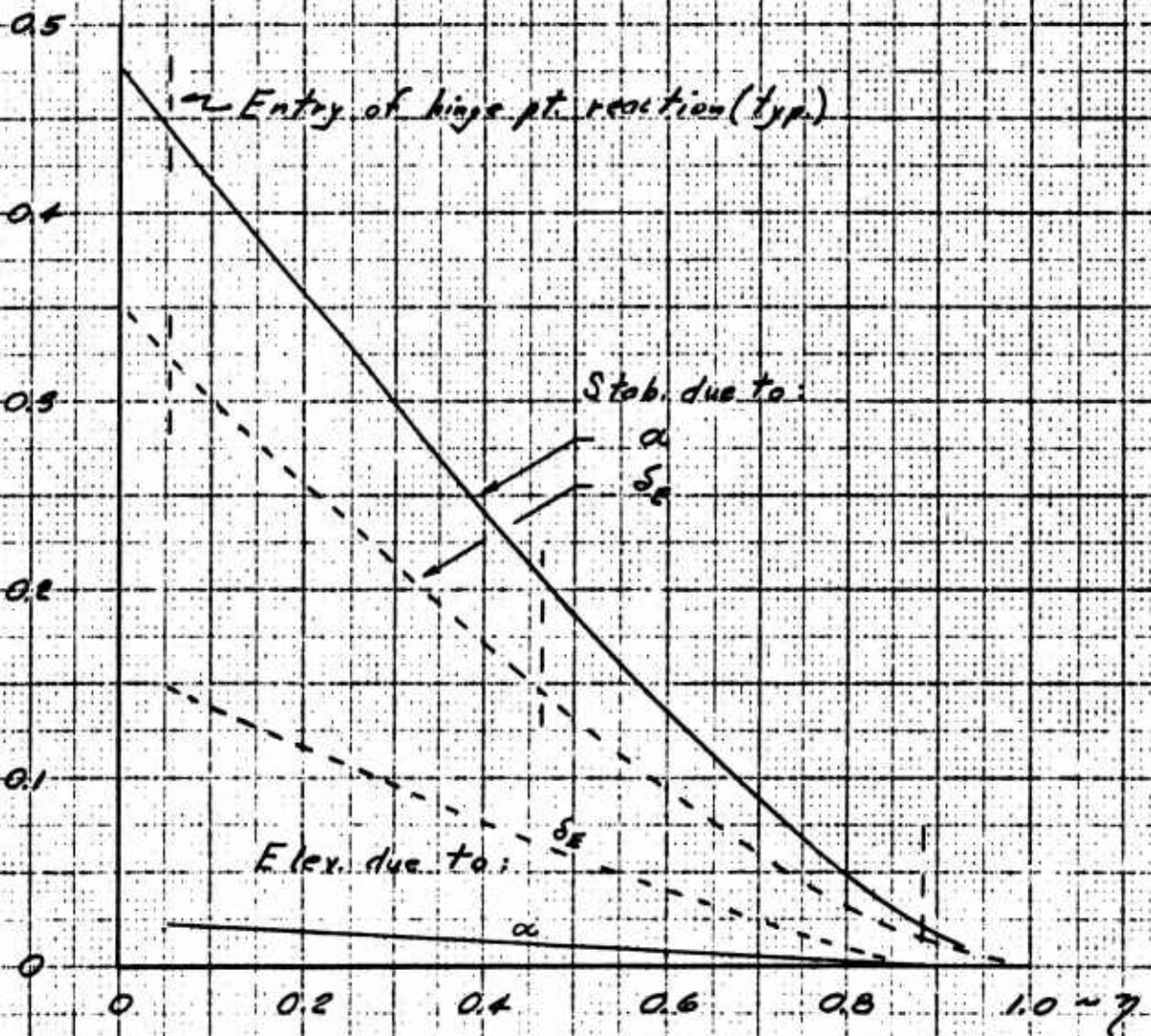

Figure 4.67 Stabilizer and Elevator Unit Shear Due to α & δ_E

Notes:

- 1) Mach No. ≤ 0.756
- 2) Stab. bending is excl. of elev. reactions
- 3) Ref. axis = F. Sta. 496.

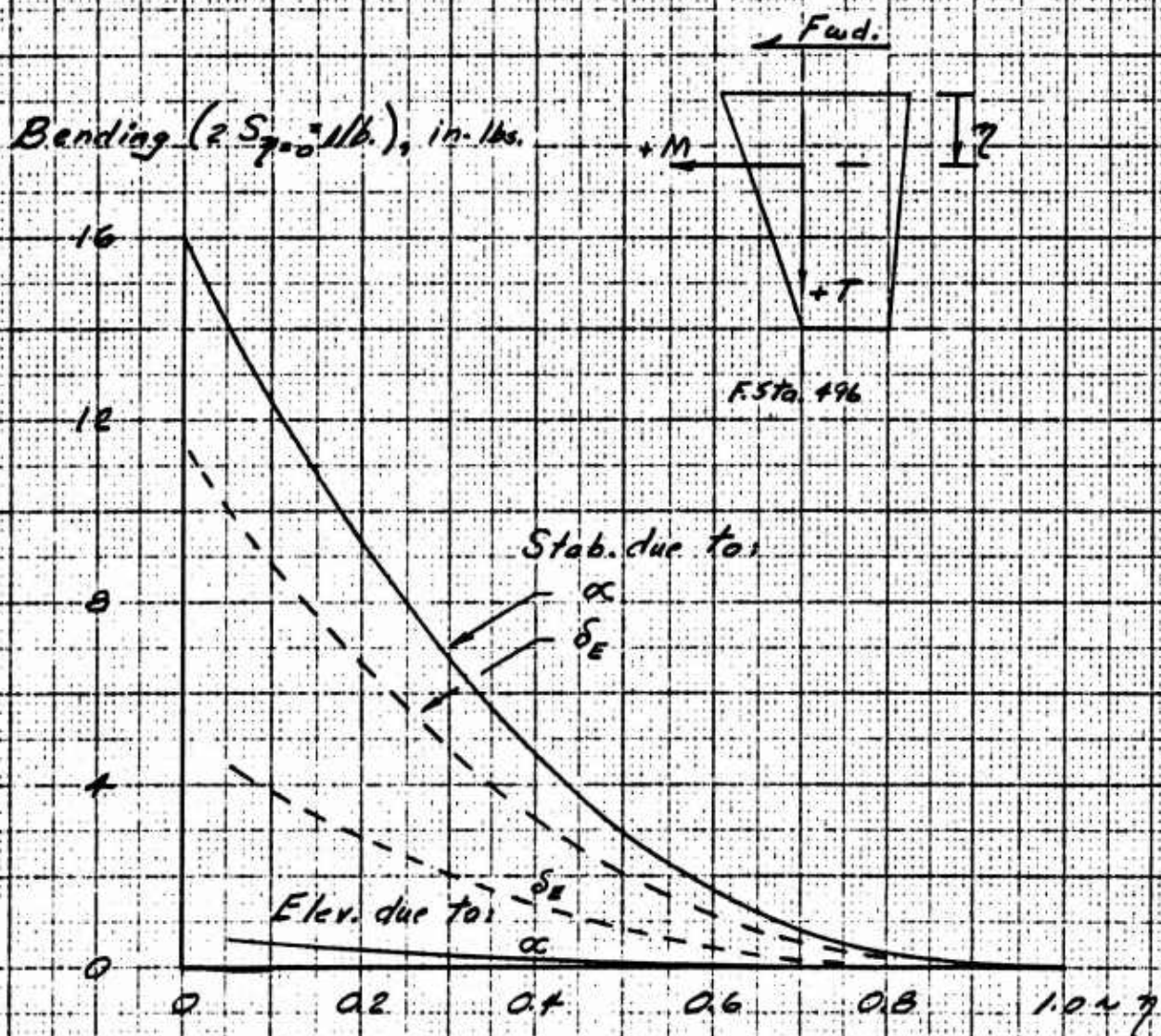

Figure 4.68 Stabilizer and Elevator Unit Bending Due to α & δE

Torsion ($2 S_{y=0} = 1 lb$), in-lb.

Note:

- 1) Stab. torsion is excl. of elev. reactions
- 2) Ref. axis = F. Sta. 496

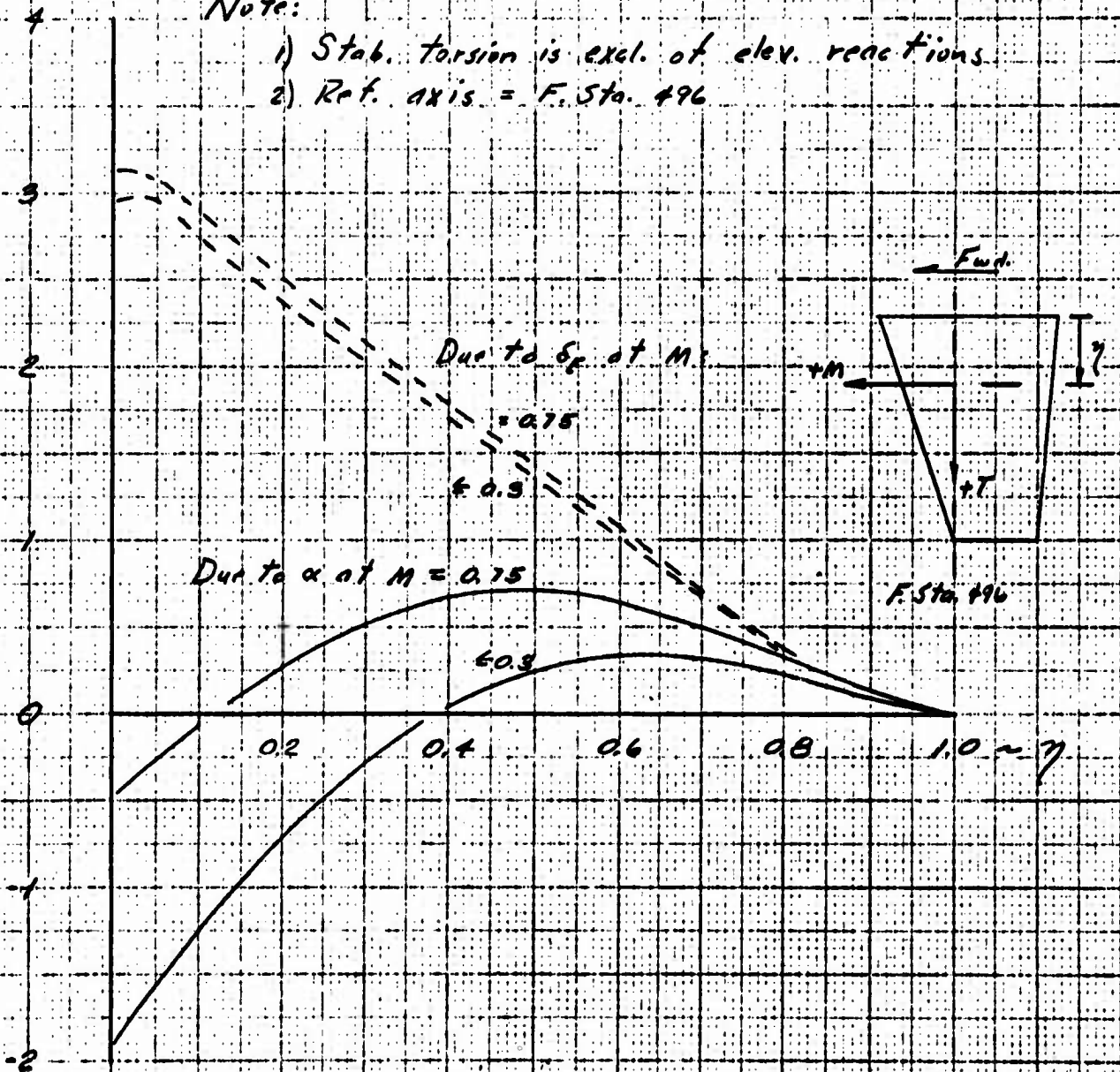

Figure 4.69 Stabilizer Unit Torsion Due to α & δ_E

Note:

- 1) Mach No. ≤ 0.756
- 2) Positive (+) shear acts against rt. side
- 3) Outbd. hinge pt. reaction (vs. Sta. 71.8) = 0.00982 lbs.
- 4) Inbd. " " " (vs. Sta. 6.8) = 0.00762 lbs.
- 5) Ref. axis = Ctr. Spar (45% c)

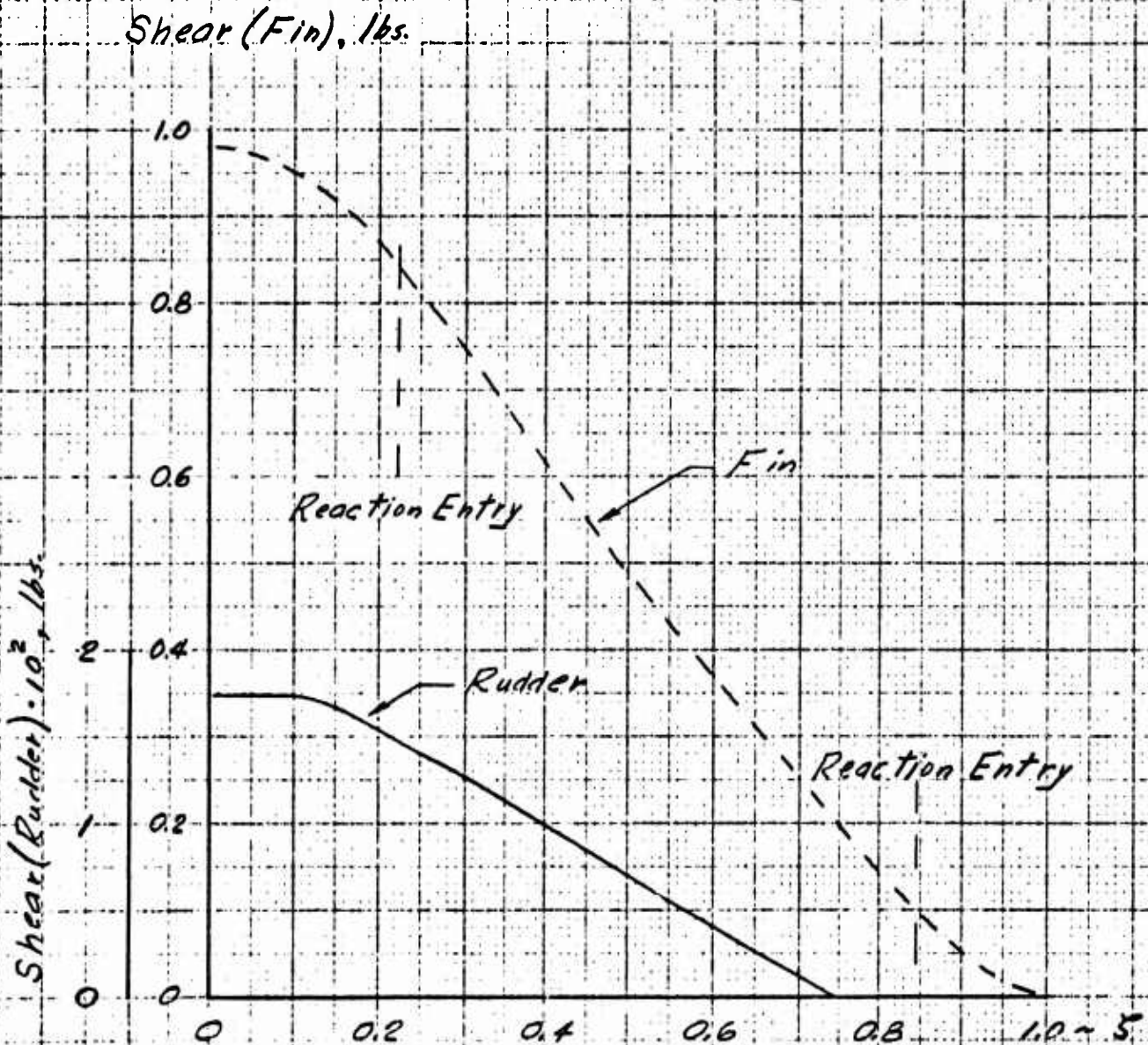

Figure 4.70 Fin and Rudder Unit Shear Due to β

Note:

- 1) Rudder bending incl. hinge moment component
- 2) Rudder hinge moment = -0.0895 in-lbs.
- 3) Fin bending is excl. of rudder reactions
- 4) Ref. axis = Ctr. Spar (45% c)

Bending, Fin ($S_{S=0}$ 1 lb.), in-lbs.

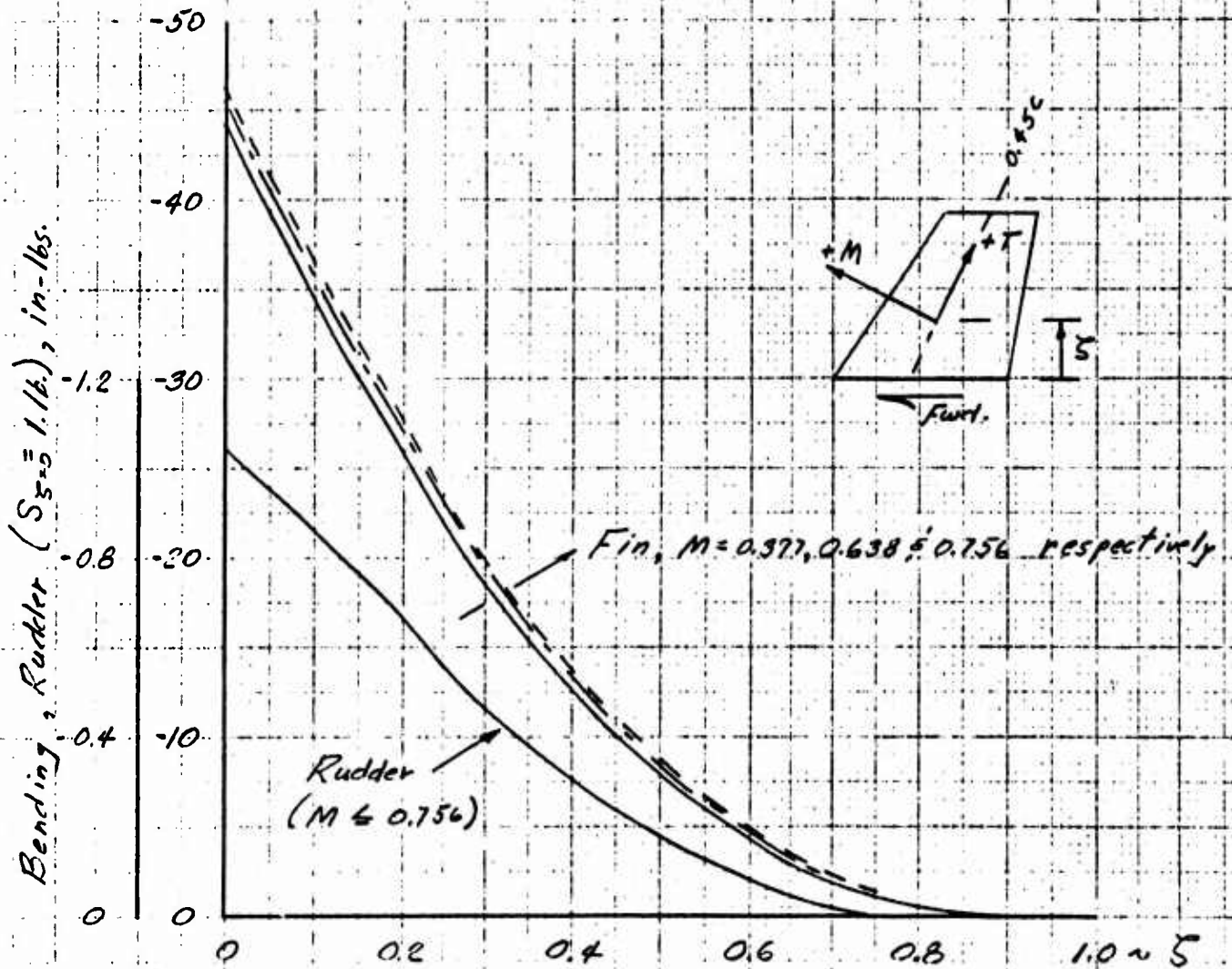

Figure 4.71 Fin and Rudder Unit Bending Due to β

Note:

- 1) Rudder torsion incl. hinge moment component
- 2) Rudder hinge moment = -0.0895 in-lbs.
- 3) Fin torsion is excl. of rudder reactions
- 4) Ref. axis = Ctr. Spar (45% c)

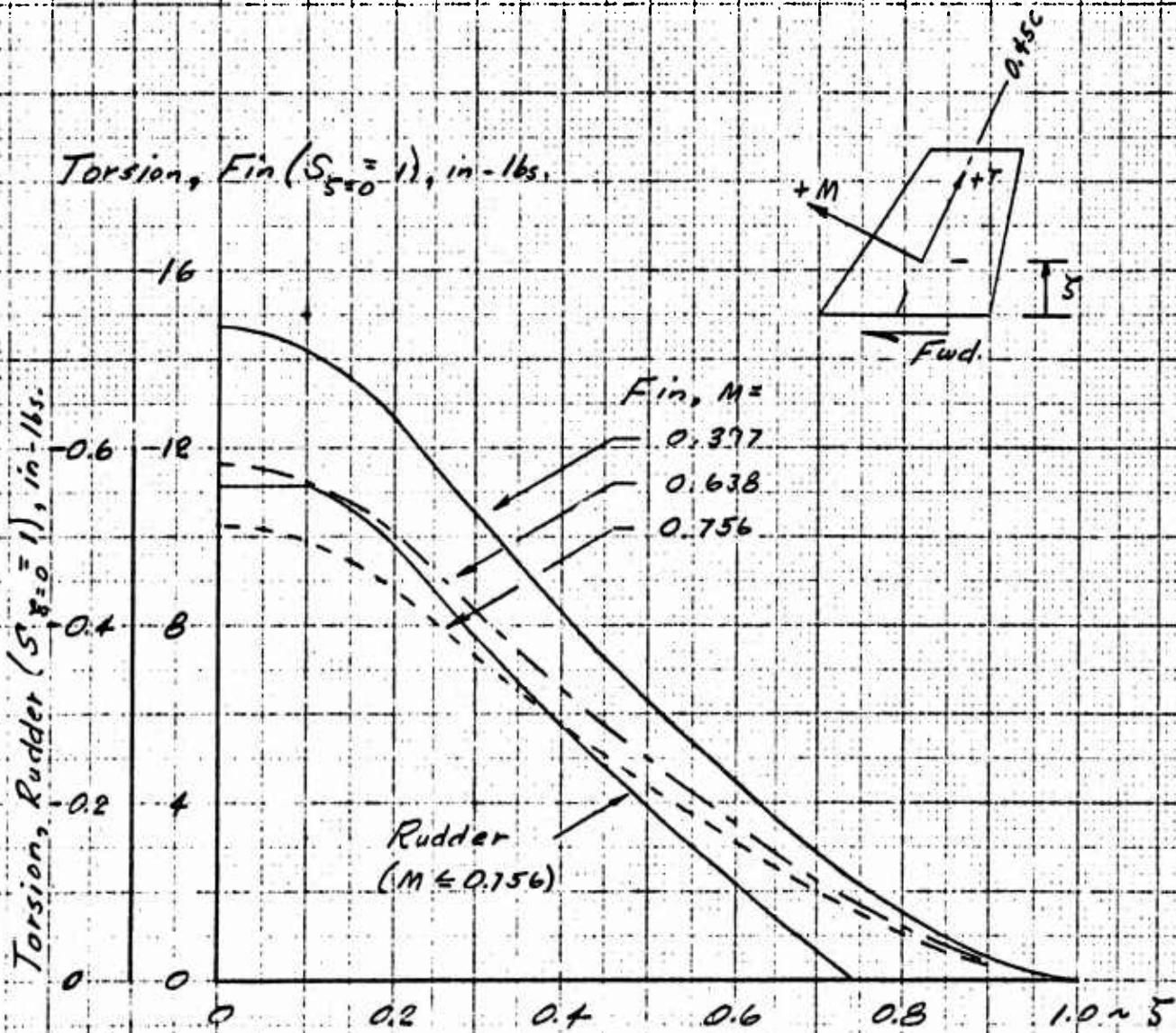

Figure 4.72 Fin and Rudder Unit Torsion Due to β

Note:

- 1) Mach No. ≤ 0.756
- 2) Positive(+) shear acts against rt. side
- 3) Outbd. hinge pt. reaction (V.S. Sta. 71.8) = 0.307417 lbs.
- 4) Inbd. " " " (V.S. Sta. 6.8) = 0.358657 lbs.
- 5) Ref. axis = Ctr. Spar (45% c)

Shear, lbs.

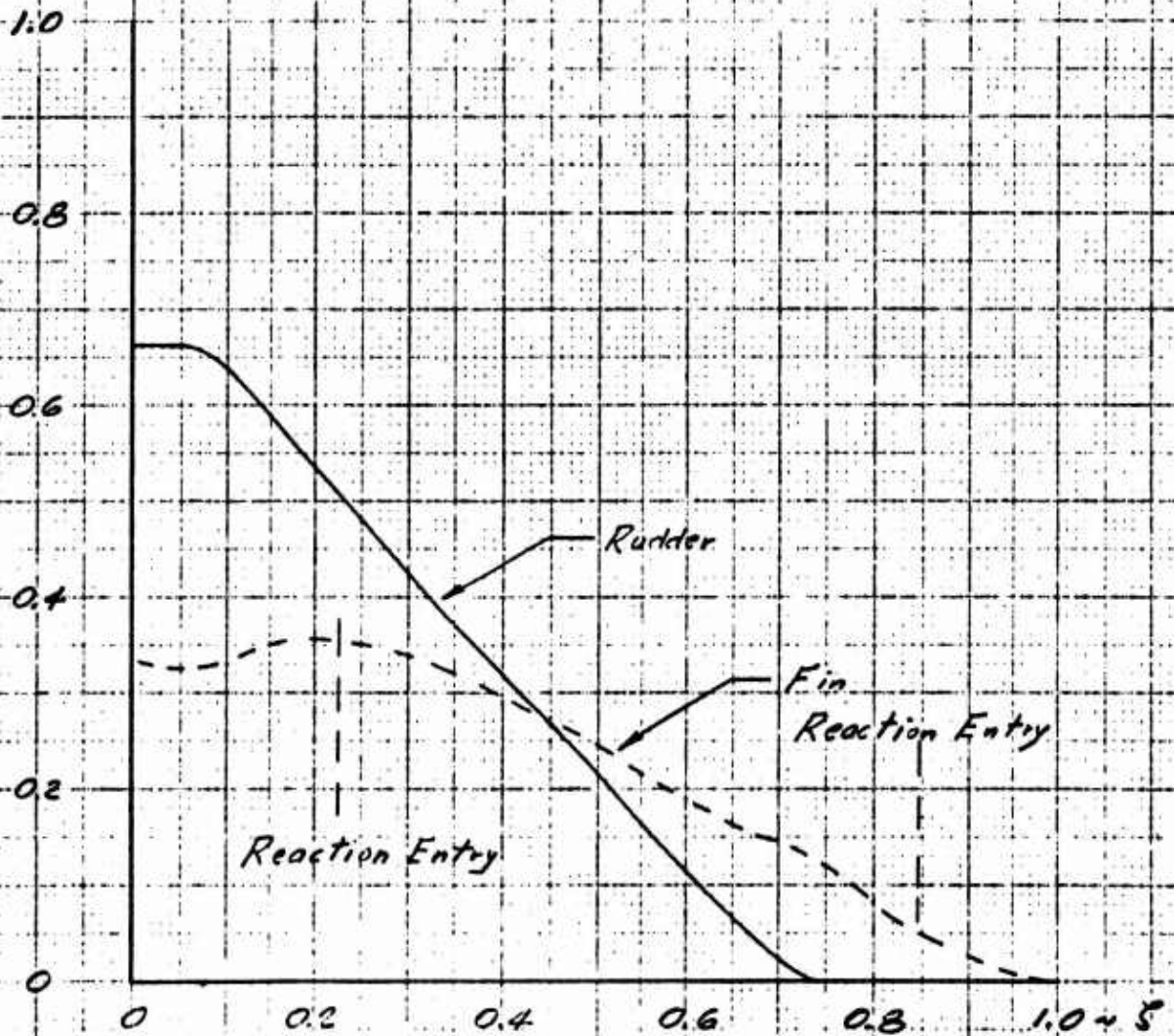

Figure 4.73 Fin and Rudder Unit Shear Due to δ_R

Note:

- 1) Rudder bending incl. hinge moment component
- 2) Rudder hinge moment = -2.047 in-lbs.
- 3) Fin bending is excl. of rudder reactions
- 4) Ref. axis = Ctr. Spar (45% c)

Bending ($S_{5=0} = 1 lb$), in-lbs.

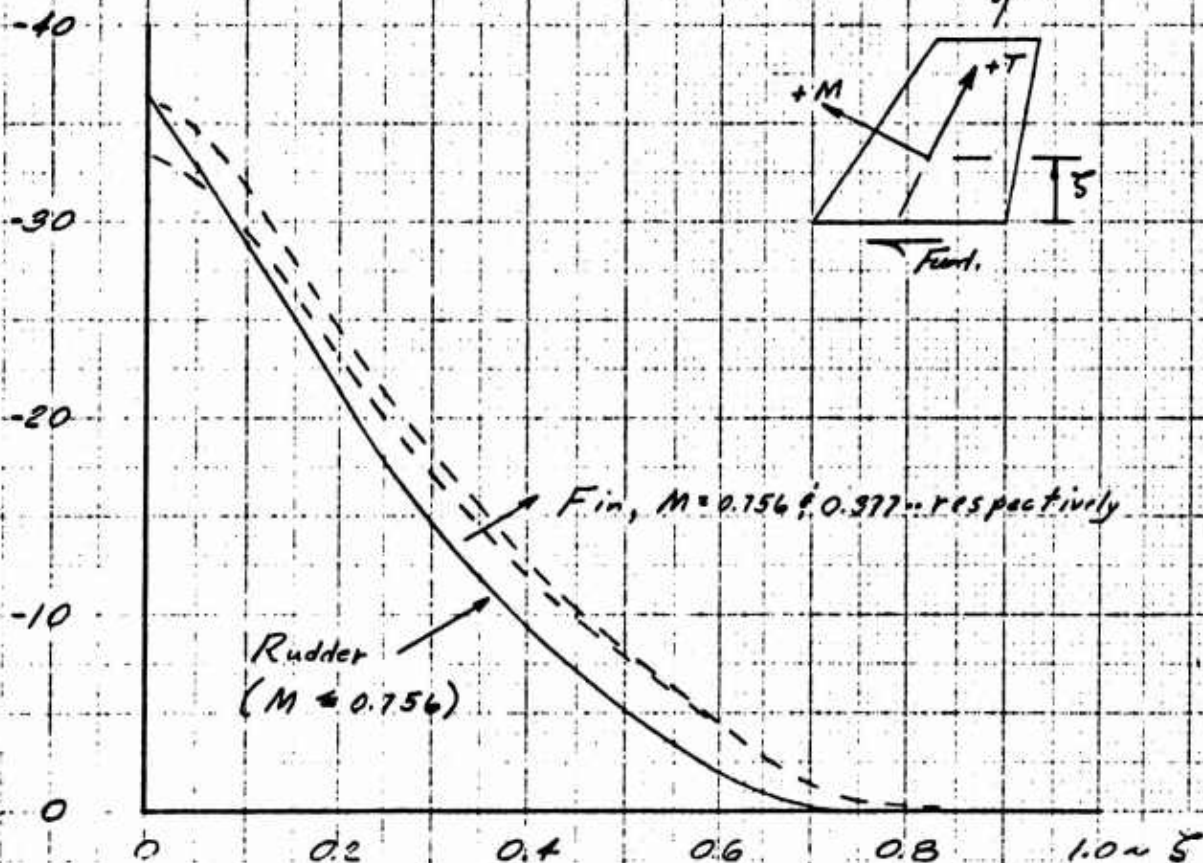

Figure 4.74 Fin and Rudder Unit Bending Due to δ_R

Note:

- 1) Rudder torsion incl. hinge moment component
- 2) Rudder hinge moment = -2.047 in-lbs.
- 3) Fin torsion is excl. of rudder reactions
- 4) Ref. axis = Ctr. Spar (45% c)

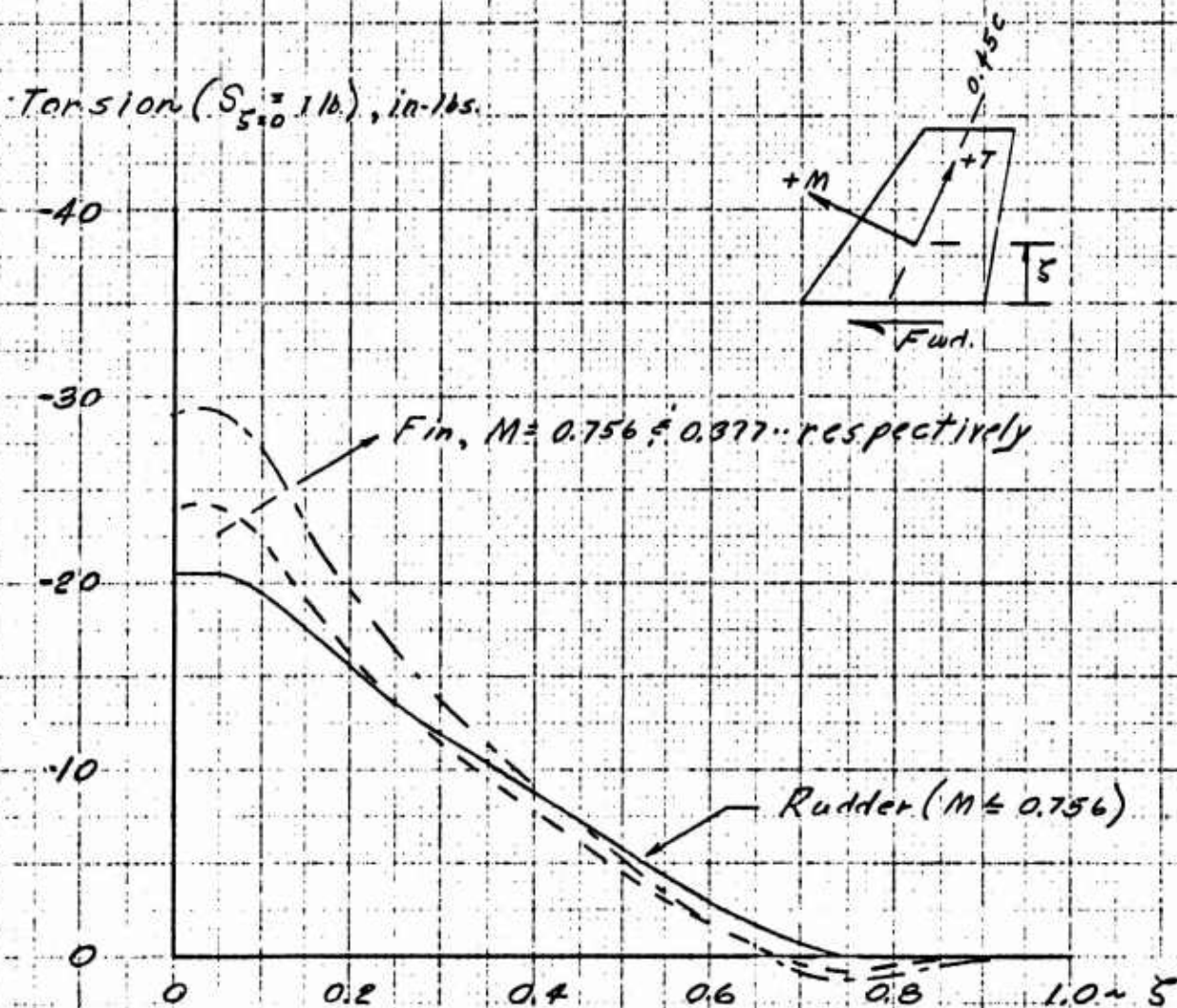

Figure 4.75 Fin and Rudder Unit Torsion Due to δ_R

A complete listing of elastic coefficients - the ratio of an elastic stability derivative to its corresponding rigid value - is presented in Table 4.80 in terms of tail and "model-minus-tail" contributions. Figures 4.76 through 4.78 provide a graphic portrayal of a few of the most important of these terms.

All of the foregoing data include the effects of fuselage bending and pertain to a body axis system - orthogonal, right-hand rule, x positive forward - at small angular perturbations.

To illustrate the significance of fuselage bending to the above net tail coefficients, data for an elastic tail, but rigid fuselage, are also shown in Tables 4.81 through 4.88. These data also provide theoretical rigid tail stability derivatives upon which the elastic coefficients were based. Particular attention should be devoted to the theoretical rotary derivatives shown therein before establishing an actual finite value for an elastic derivative. Also observe the coefficients to be relevant to (1) wing geometry, (2) $d\epsilon/d\alpha = f(\text{Mach})$, (3) $d\sigma/d\beta = 0$, (3) $q_T/q_\infty = 1.0$, and (4) c.g. = F. Sta. 246.

RYAN

Coeff. for :	M=.3 Alt.=0	M=.6 Alt.=0	M=.8 Alt.=0		M=.3 20,000'	M=.6 20,000'	M=.8 20,000'
<u>Wing-Tail ...</u>							
α_{0L}	0.984	0.995	0.805		0.993	0.970	0.915
$C_{N\alpha}$	1.003	1.011	1.019		1.001	1.005	1.009
$C_{m\alpha}$	0.980	0.923	0.955		0.990	0.965	0.979
$C_{m\alpha} \sim F.57d 240$	0.996	0.985	0.984		0.998	0.993	0.993
$C_{m\alpha} \sim F.57d 246$	0.999	0.975	0.994		0.999	0.998	0.997
$C_{L\beta}$	0.964	0.850	0.732		0.982	0.931	0.875
C_{Lp}	0.997	0.985	0.974		0.999	0.994	0.988
<u>Empennage ...</u>							
$C_{N\alpha}$	0.966	0.865	0.746		0.984	0.933	0.864
$C_{N\beta}$	0.732	0.764	0.633		0.968	0.881	0.777
$C_{N\gamma}$	0.966	0.866	0.745		0.984	0.933	0.864
$C_{m\alpha}$	0.966	0.865	0.745		0.984	0.933	0.864
$C_{m\beta}$	0.936	0.777	0.647		0.970	0.887	0.806
$C_{m\gamma}$	0.966	0.866	0.745		0.984	0.933	0.864
$C_{Y\beta}$	0.974	0.899	0.870		0.988	0.951	0.936
$C_{Y\beta R}$	0.954	0.836	0.795		0.979	0.920	0.898
C_{Yp}	0.959	0.845	0.787		0.981	0.924	0.894
C_{Yr}	0.974	0.898	0.868		0.988	0.950	0.935
$C_{N\beta}$	0.974	0.898	0.869		0.988	0.951	0.935
$C_{N\beta R}$	0.961	0.858	0.820		0.982	0.931	0.911
C_{Np}	0.960	0.845	0.788		0.981	0.925	0.907
C_{Nr}	0.974	0.897	0.868		0.988	0.950	0.935
$C_{L\beta}$	0.974	0.896	0.862		0.988	0.949	0.932
$C_{L\beta R}$	0.950	0.822	0.781		0.977	0.913	0.891
C_{Lp}	0.981	0.891	0.858		0.987	0.947	0.930
C_{Lr}	0.974	0.896	0.863		0.988	0.950	0.932

Table 4.80 Elastic Coefficients In Terms of Elastic/Rigid Ratios

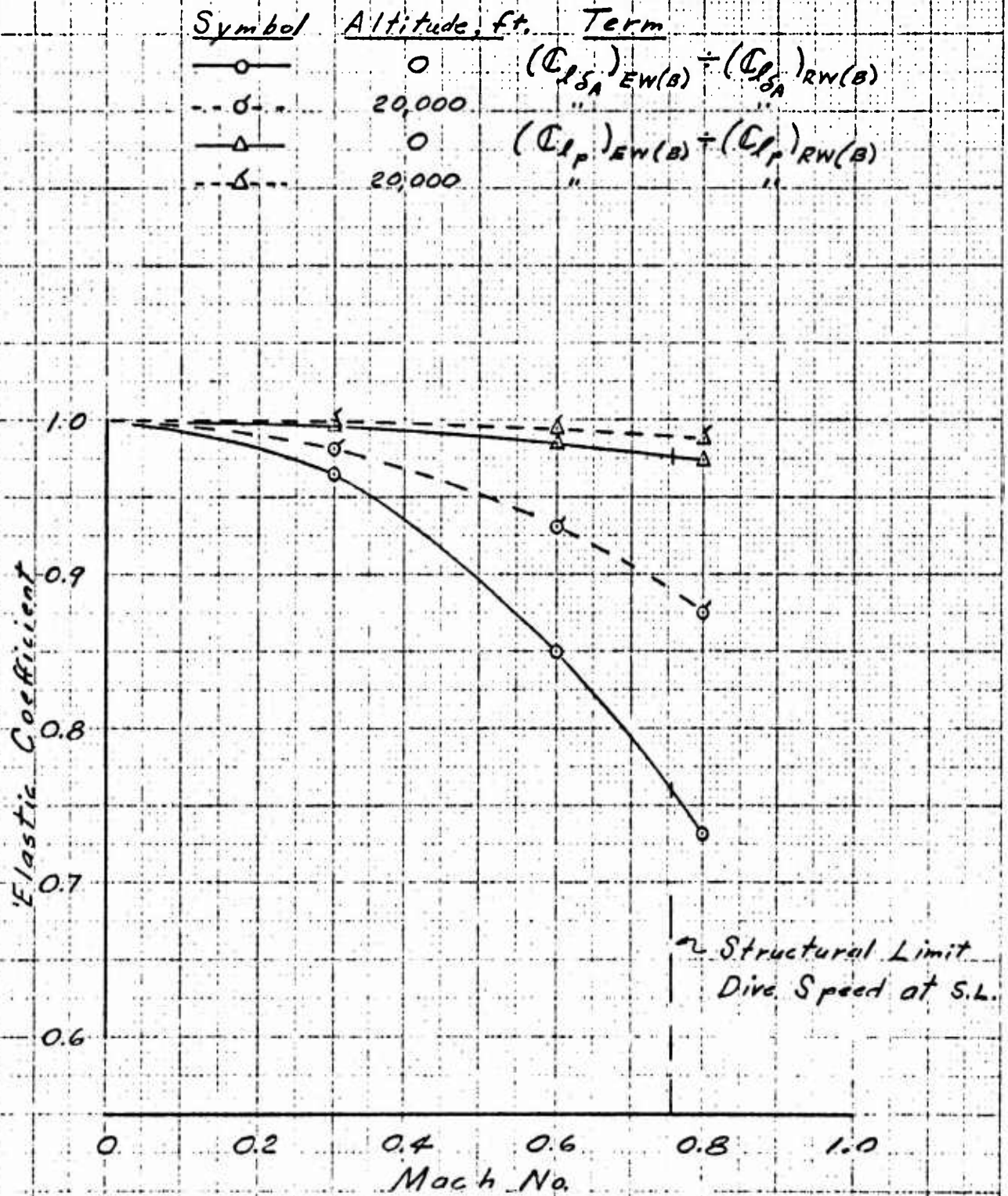

Figure 4.76 Wing - Body Elastic Coefficients, Rolling Mode

Symbol	Altitude, ft.	Term
○	0	$(C_{m\alpha})_{ETEB} - (C_{m\alpha})_{RTRB}$
○	20,000	" "
△	0	$(C_{m\delta})_{ETEB} - (C_{m\delta})_{RTRB}$
△	20,000	" "

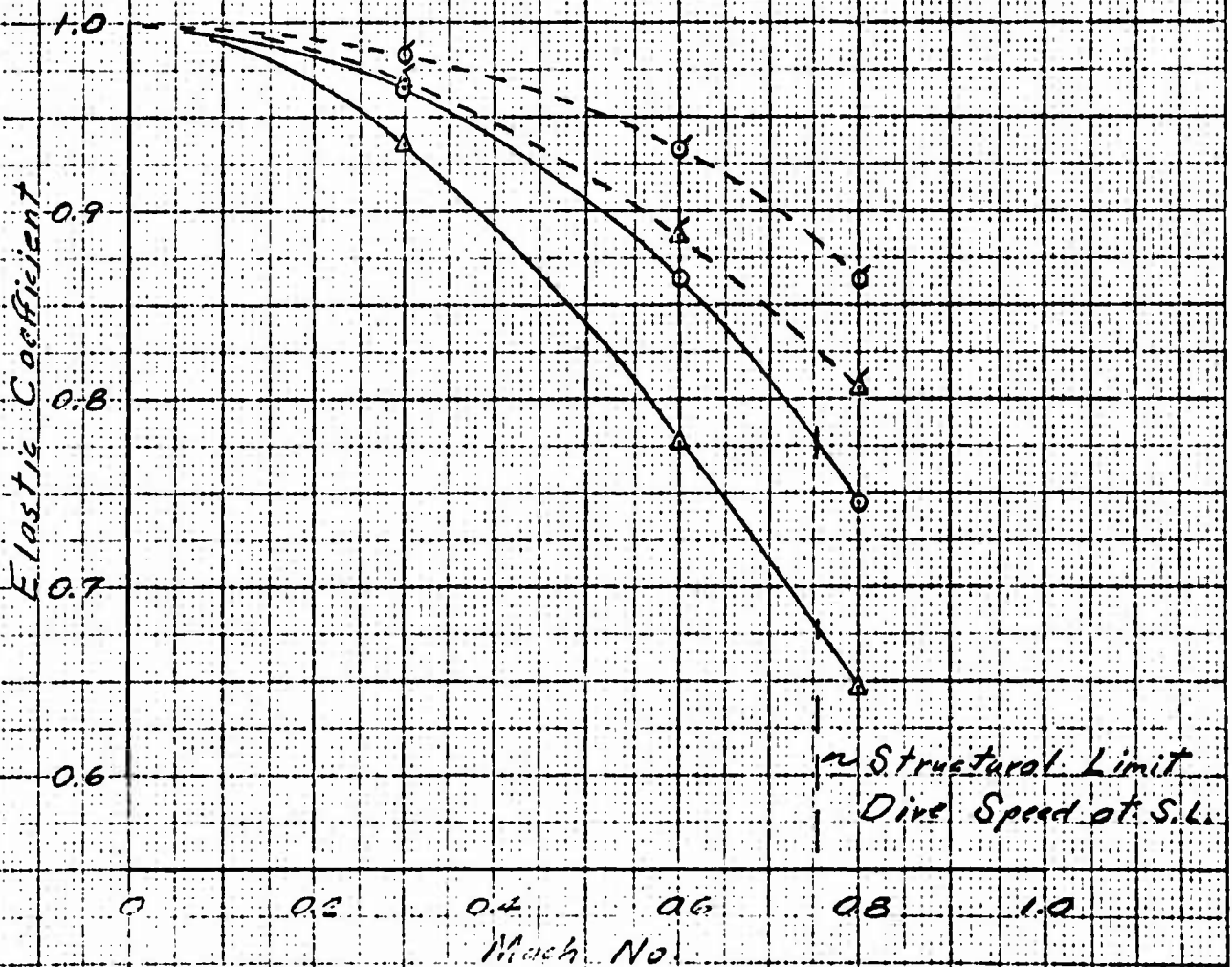

Figure 4.77 Empennage Elastic Coefficients, Pitching Mode

Symbol	Altitude, ft.	Term
○	0	$(C_{np})_{ETEB} = (C_{np})_{RTRB}$
○	20,000	" "
△	0	$(C_{n_{\dot{\beta}}})_{ETEB} = (C_{n_{\dot{\beta}}})_{RTRB}$
△	20,000	" "

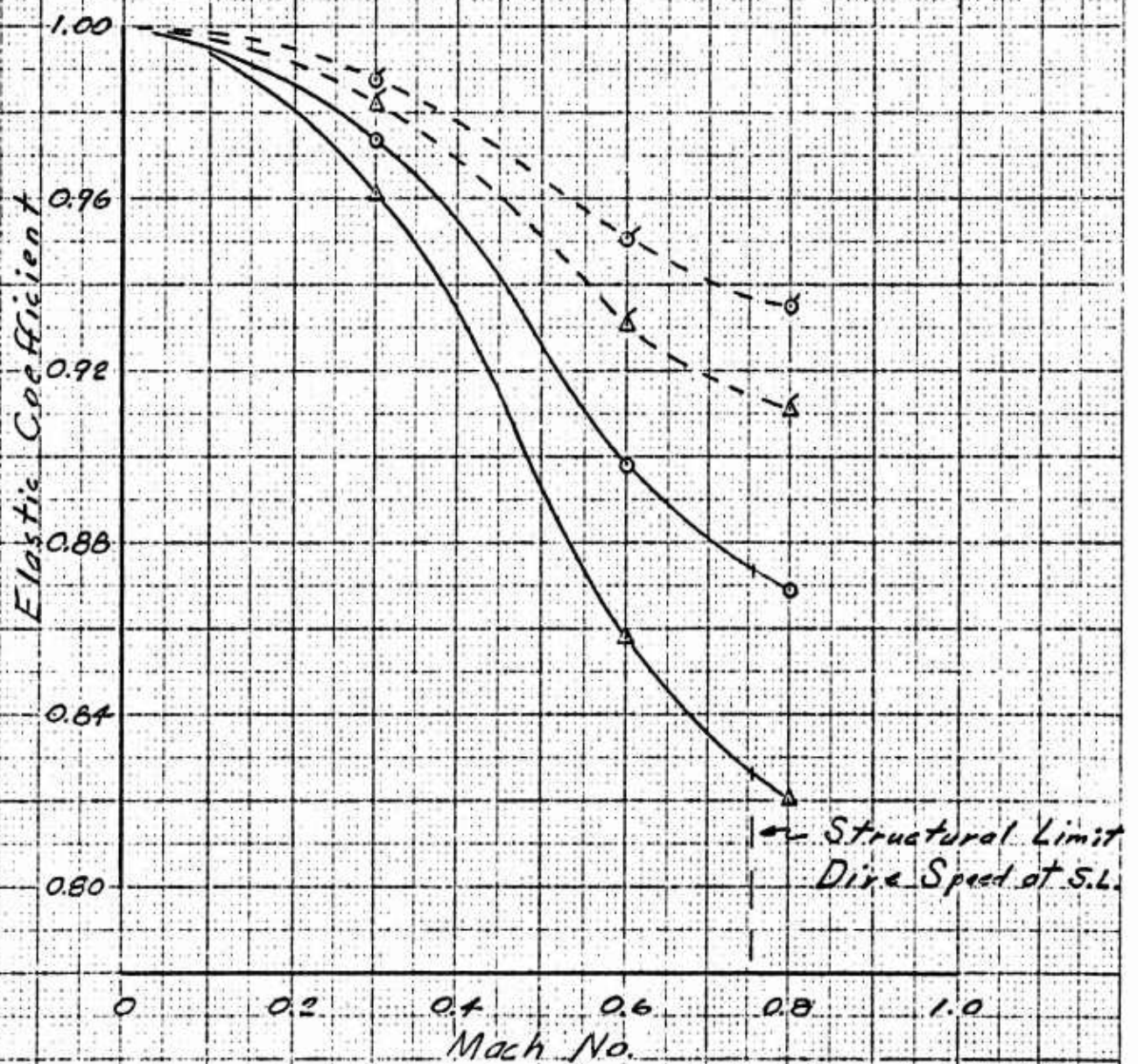

Figure 4.78 Empennage Elastic Coefficients, Yawing Mode

STABILITY DERIVATIVES

RIGID X 100

	BETA	ALPHA	DR	DE	P	Q	R
	5.00	-5.00	10.00	10.00	1.75	1.75	1.75
CY	-0.8816		0.2070		-15.5072		64.2423
-CZ		0.7130		0.5554		294.4757	
CMZ	0.5359		-0.1502		9.6092		-39.1532
CMY		-1.5613		-1.3015		-644.9423	
CMX-VT	-0.1269		0.0289		-2.5498		9.4278
CMX-HT	-0.0321		0.0068	-0.0018	-1.7968		2.3706
CMX-TOT	-0.1590		0.0357		-4.3466		11.7984

ELASTIC COEFFICIENTS

CY	0.9921		0.9846		0.9783		0.9920
-CZ		1.0040		0.9771		1.0040	
CMZ	0.9919		0.9868		0.9782		0.9918
CMY		1.0040		0.9785		1.0040	
CMX-VT	0.9908		0.9816		0.9775		0.9908
CMX-HT	0.9954		0.9846	0.8362	0.9951		0.9955
CMX-TOT	0.9917		0.9822		0.9848		0.9917

Table 4.81 Theoretical Stability Derivatives, Empennage (Rigid Fuselage), $M = .3$,
Alt. = 0 S.L.

STABILITY DERIVATIVES

RIGID X 100

	BETA	ALPHA	DR	DE	P	Q	R
	5.00	-5.00	10.00	10.00	1.75	1.75	1.75
CY	-0.8816		0.2070		-15.5072		64.2423
-CZ		0.7130		0.5554		294.4757	
CMZ	0.5359		-0.1502		9.6092		-39.1532
CMY		-1.5613		-1.3015		-644.9423	
CMX-VT	-0.1269		0.0289		-2.5498		9.4278
CMX-HT	-0.0321		0.0068	-0.0018	-1.7968		2.3706
CMX-TOT	-0.1590		0.0357		-4.3466		11.7984

ELASTIC COEFFICIENTS

CY	0.9964		0.9929		0.9900		0.9963
-CZ		1.0018		0.9893		1.0018	
CMZ	0.9963		0.9939		0.9899		0.9962
CMY		1.0018		0.9900		1.0018	
CMX-VT	0.9957		0.9915		0.9896		0.9957
CMX-HT	0.9979		0.9929	0.9219	0.9978		0.9979
CMX-TOT	0.9962		0.9918		0.9930		0.9962

Table 4.82 Theoretical Stability Derivatives, Empennage (Rigid Fuselage), $M = .3$,
Alt. = 20,000

STABILITY DERIVATIVES

RIGID X 100

	BETA	ALPHA	DR	DE	P	Q	R
	5.00	-5.00	10.00	10.00	1.75	1.75	1.75
CY	-0.8974		0.2116		-15.9492		68.7194
-CZ		0.7530		0.5842		316.0167	
CMZ	0.5513		-0.1513		9.9753		-42.3279
CMY		-1.6591		-1.3655		-696.5050	
CMX-VT	-0.1288		0.0295		-2.6074		10.0711
CMX-HT	-0.0317		0.0068	0.0025	-1.8179		2.4582
CMX-TOT	-0.1605		0.0363		-4.4253		12.5292

ELASTIC COEFFICIENTS

CY	0.9673		0.9430		0.9133		0.9666
-CZ		1.0059		0.9159		1.0064	
CMZ	0.9666		0.9500		0.9128		0.9659
CMY		1.0060		0.9203		1.0065	
CMX-VT	0.9618		0.9321		0.9099		0.9617
CMX-HT	0.9713		0.9360	1.2678	0.9723		0.9713
CMX-TOT	0.9637		0.9328		0.9355		0.9636

Table 4.83 Theoretical Stability Derivatives, Empennage (Rigid Fuselage), $M = .6$,
Alt. = S. L.

STABILITY DERIVATIVES

RIGID X 100

	BETA	ALPHA	DR	DE	P	Q	R
	5.00	-5.00	10.00	10.00	1.75	1.75	1.75
ζY	-0.8974		0.2116		-15.9492		68.7194
$-\zeta Z$		0.7530		0.5842		316.0167	
ζMZ	0.5513		-0.1513		9.9753		-42.3279
ζMY		-1.6591		-1.3655		-696.5050	
$\zeta MX-VT$	-0.1288		0.0295		-2.6074		10.0711
$\zeta MX-HT$	-0.0317		0.0068	0.0025	-1.8179		2.4582
$\zeta MX-TOT$	-0.1605		0.0363		-4.4253		12.5292

ELASTIC COEFFICIENTS

ζY	0.9847		0.9731		0.9593		0.9843
$-\zeta Z$		1.0027		0.9590		1.0029	
ζMZ	0.9844		0.9764		0.9591		0.9840
ζMY		1.0028		0.9612		1.0030	
$\zeta MX-VT$	0.9821		0.9679		0.9577		0.9821
$\zeta MX-HT$	0.9866		0.9698	1.1454	0.9871		0.9866
$\zeta MX-TOT$	0.9830		0.9683		0.9698		0.9830

Table 4.84 Theoretical Stability Derivatives, Empennage (Rigid Fuselage), $M = .6$,
Alt. = 20,000

STABILITY DERIVATIVES

RIGID X 100

	BETA	ALPHA	DR	DE	P	Q	R
	5.00	-5.00	10.00	10.00	1.75	1.75	1.75
CY	-0.7058		0.1782		-11.3774		58.5956
-CZ		0.7989		0.6270		352.9265	
CMZ	0.4396		-0.1270		7.2201		-36.6127
CMY		-1.7831		-1.4626		-787.9489	
CMX-VT	-0.0945		0.0236		-1.7757		8.0583
CMX-HT	-0.0162		0.0041	0.0089	-1.4801		1.3290
CMX-TOT	-0.1107		0.0277		-3.2558		9.3874

ELASTIC COEFFICIENTS

CY	0.9672		0.9379		0.8813		0.9661
-CZ		0.9728		0.8587		0.9728	
CMZ	0.9665		0.9445		0.8804		0.9654
CMY		0.9727		0.8643		0.9727	
CMX-VT	0.9605		0.9252		0.8748		0.9604
CMX-HT	0.9451		0.9149	0.9932	0.9512		0.9446
CMX-TOT	0.9583		0.9237		0.9095		0.9582

Table 4.85 Theoretical Stability Derivatives, Empennage (Rigid Fuselage), $M = .8$,
Alt. = S. L.

STABILITY DERIVATIVES

RIGID X 100

	BETA	ALPHA	DR	DE	P	Q	R
	5.00	-5.00	10.00	10.00	1.75	1.75	1.75
CY	-0.7058		0.1782		-11.3774		58.5956
-CZ		0.7989		0.6270		352.9265	
CMZ	0.4396		-0.1270		7.2201		-36.6127
CMY		-1.7831		-1.4626		-787.9489	
CMX-VT	-0.0945		0.0236		-1.7757		8.0583
CMX-HT	-0.0162		0.0041	0.0089	-1.4801		1.3290
CMX-TOT	-0.1107		0.0277		-3.2558		9.3874

ELASTIC COEFFICIENTS

CY	0.9845		0.9704		0.9435		0.9840
-CZ		0.9873		0.9282		0.9873	
CMZ	0.9841		0.9736		0.9431		0.9837
CMY		0.9872		0.9311		0.9873	
CMX-VT	0.9813		0.9644		0.9404		0.9813
CMX-HT	0.9740		0.9594	1.0029	0.9769		0.9738
CMX-TOT	0.9803		0.9636		0.9570		0.9802

Table 4.86 Theoretical Stability Derivatives, Empennage (Rigid Fuselage), $M = .8$,
Alt. = 20,000

STABILITY DERIVATIVES

RIGID X 100

	BETA	ALPHA	DR	DE	P	Q	R
	5.00	-5.00	10.00	10.00	1.75	1.75	1.75
CY	-0.2087		0.0501		-2.6164		19.3152
-CZ		0.3057		0.1779		107.0678	
CMZ	0.1366		-0.0395		1.7575		-12.7059
CMY		-0.7039		-0.4375		-246.6070	
CMX-VT	-0.0266		0.0066		-0.4371		2.6215
CMX-HT	0.0016		0.0002	-0.0678	-0.5010		0.0641
CMX-TOT	-0.0250		0.0068		-0.9382		2.6856

ELASTIC COEFFICIENTS

CY	0.9928		0.9750		0.9437		0.9889
-CZ		0.9567		0.8882		0.9559	
CMZ	0.9926		0.9786		0.9431		0.9886
CMY		0.9565		0.8947		0.9557	
CMX-VT	0.9903		0.9670		0.9377		0.9856
CMX-HT	0.8574		0.9326	0.7984	0.9448		0.9403
CMX-TOT	0.9991		0.9661		0.9415		0.9845

Table 4.87 Theoretical Stability Derivatives, Empennage (Rigid Fuselage), M = .9,
Alt. = S. L.

STABILITY DERIVATIVES

RIGID X 100

	BETA	ALPHA	DR	DE	P	Q	R
	5.00	-5.00	10.00	10.00	1.75	1.75	1.75
CY	-0.2087		0.0501		-2.6164		19.3152
-CZ		0.3057		0.1779		107.0678	
CMZ	0.1366		-0.0395		1.7575		-12.7059
CMY		-0.7039		-0.4375		-246.6070	
CMX-VT	-0.0266		0.0066		-0.4371		2.6215
CMX-HT	0.0016		0.0002	-0.0678	-0.5010		0.0641
CMX-TOT	-0.0250		0.0068		-0.9382		2.6856

ELASTIC COEFFICIENTS

CY	0.9967		0.9883		0.9733		0.9948
-CZ		0.9795		0.9457		0.9791	
CMZ	0.9966		0.9900		0.9730		0.9947
CMY		0.9794		0.9488		0.9790	
CMX-VT	0.9956		0.9846		0.9704		0.9933
CMX-HT	0.9311		0.9680	0.8983	0.9739		0.9717
CMX-TOT	0.9999		0.9842		0.9723		0.9928

Table 4.88 Theoretical Stability Derivatives, Empennage (Rigid Fuselage), $M = .9$,
Alt. = 20,000

4.9 MISCELLANEOUS LOADS

4.9.1 Parachute(s) Loads

Deployment of the landing chute at a maximum speed of 168 KEAS resulted in an opening shock load of:

7075 lbs.

Deployment of the smaller drag chute for spin recovery at a speed of 125 KEAS resulted in an opening shock load of:

1040 lbs.

with components

$$F_x = 594 \text{ lbs.}, F_y = -292 \text{ lbs.}, F_z = 802 \text{ lbs.}$$

Deployment of the smaller drag chute for high speed retardation at a speed of 500 KEAS ($q \approx 850$ psf) resulted in an opening shock load of:

16,597 lbs.

The above load was assumed oriented, in terms of chute α and β , with respect to the fuselage for three conditions having the following force components:

for $\alpha = \beta = 0 \dots$

$$F_x = 16,597 \text{ lbs.}, F_y = 0, F_z = 0$$

for $\alpha = 7.3^\circ, \beta = 7.8^\circ \dots$

$$F_x = 14,133 \text{ lbs.}, F_y = 2233 \text{ lbs.}, F_z = 2091 \text{ lbs.}$$

for $\alpha = 14.8^\circ, \beta = 0 \dots$

$$F_x = 16,043 \text{ lbs.}, F_y = 0, F_z = 4252$$

4.9.2 Landing Gear Loads

Loading incurred during landing is presented in Reference 7. Aerodynamic loading is summarized herein. The main gear loads are estimated for the insulated configuration.

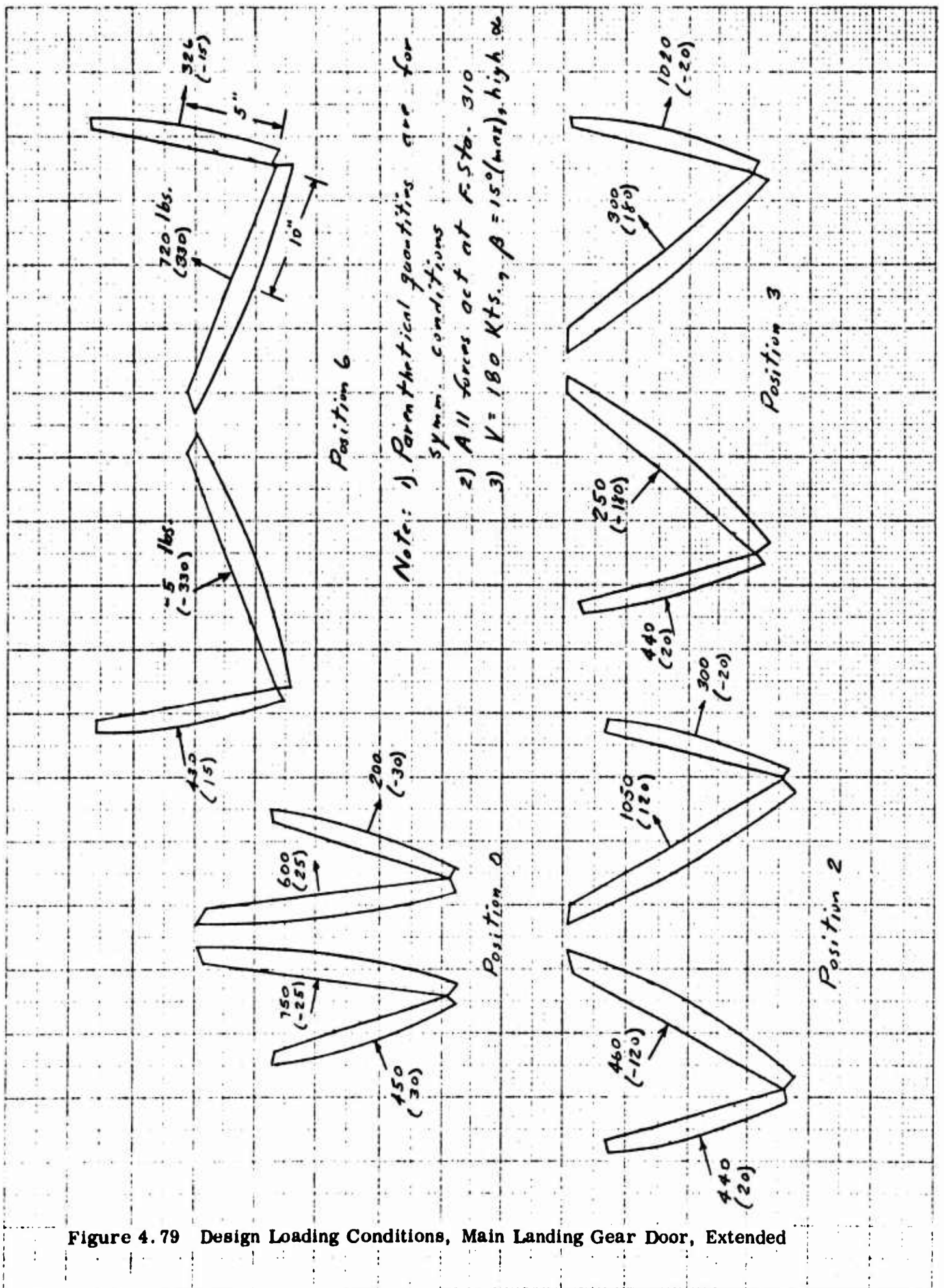

Figure 4.79 Design Loading Conditions, Main Landing Gear Door, Extended

Note: 1) $M = 0.9$, $q = 850 \text{ psf}$, $\beta = \pm 5^\circ$, $\alpha \approx 0$
 2) Internal press. assumed = $(p_{ext})_{max}$

Δp , psi

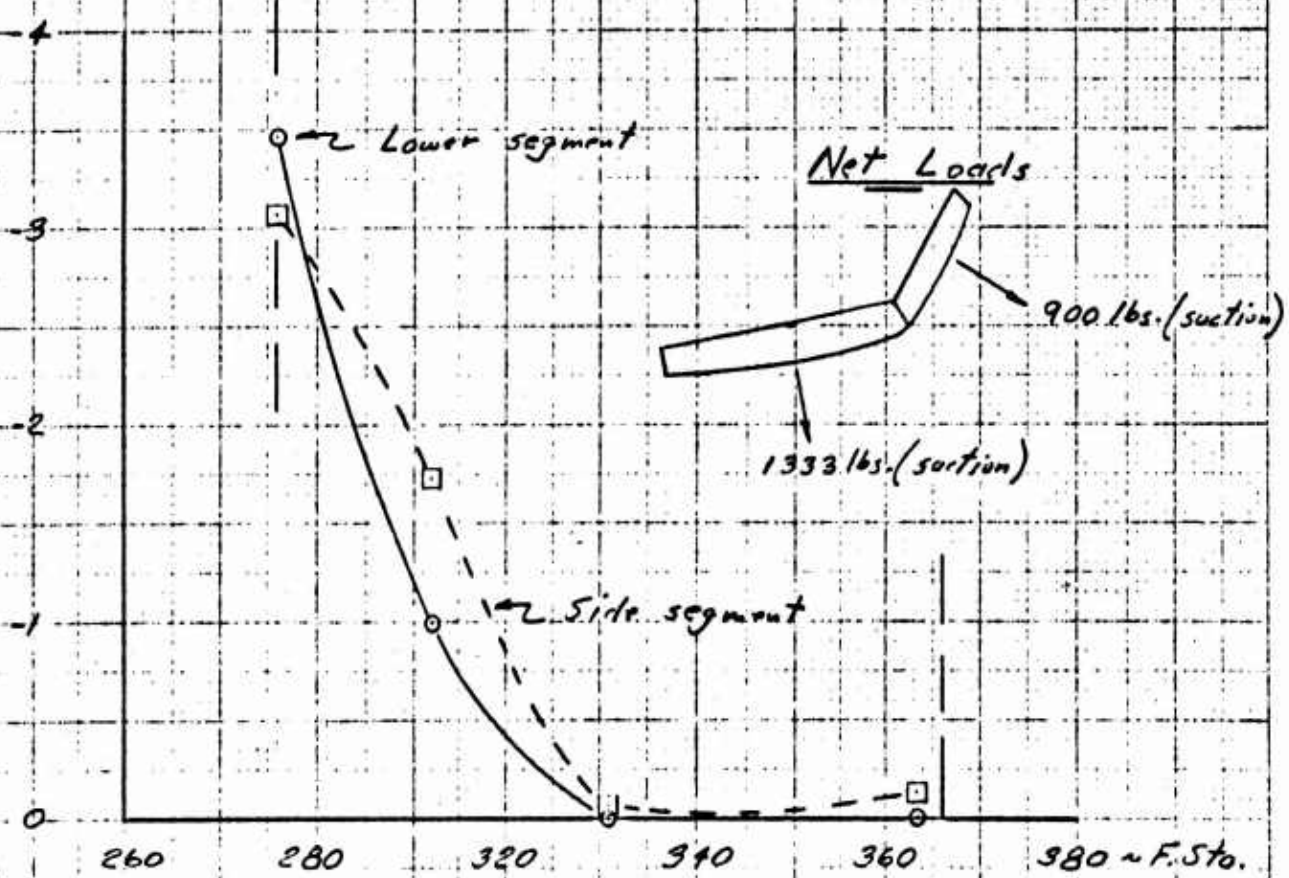

Figure 4.80 Main Landing Gear Door Loading at High Speed

Note:

- 1) $V = 180 \text{ Kts.}$, $\beta = 15^\circ (\text{max})$, high α .
- 2) Max. force on seg. ③ = 290 lbs.
- 3) Max. force on seg. ①, ② = 112 lbs.
- 4) Center of press. \cong area centroid

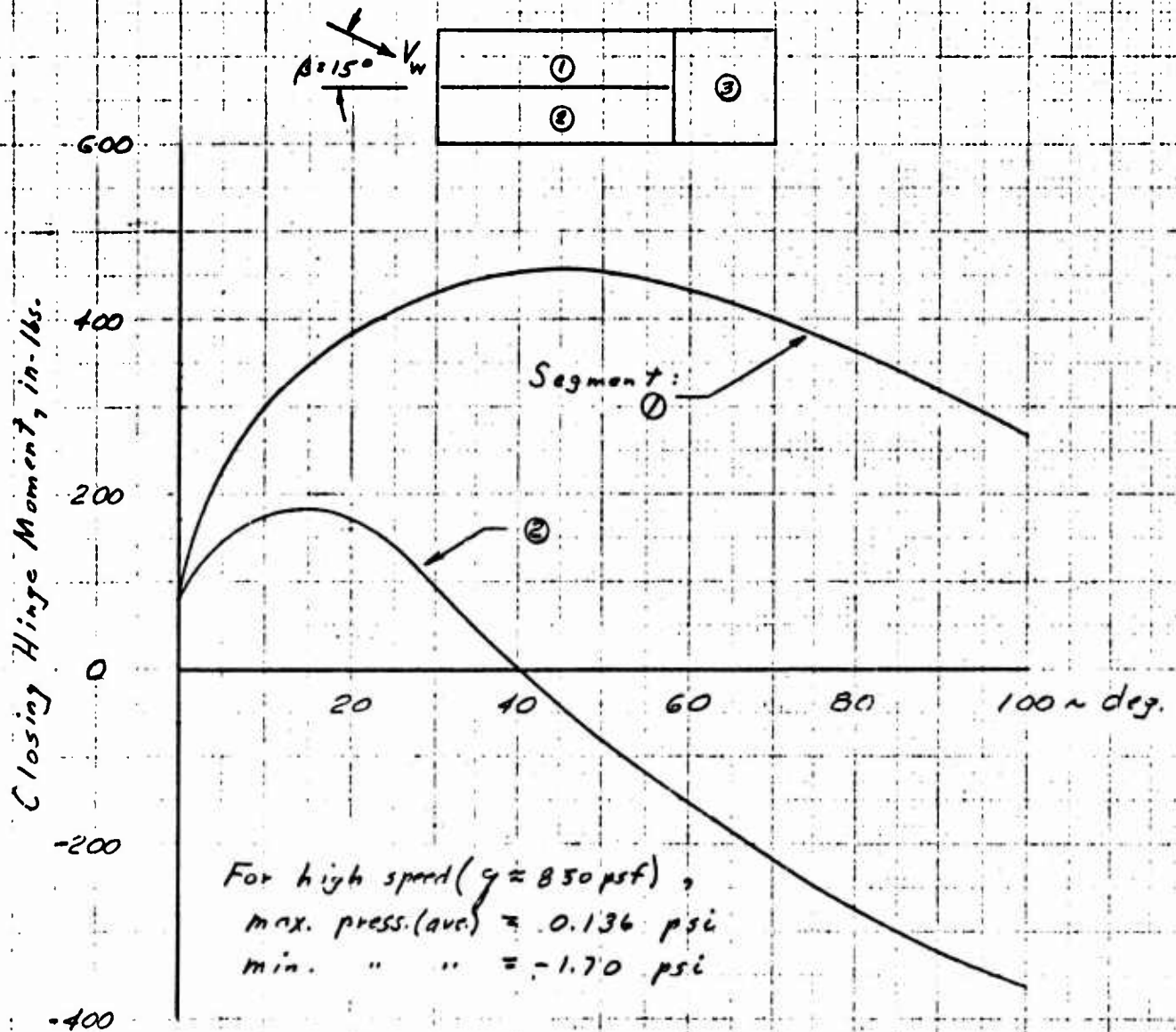

Figure 4.81 Design Loading Conditions, Nose Landing Gear Door, Extended

During landing approach (180 KEAS), the main gear (each) exclusive of drag strut and nose gear drag loads were, respectively,

$$210 \text{ lbs.} \sim Y_{cp} = \text{BL } 36.4, Z_{cp} = \text{WL } 53.2$$

$$100 \text{ lbs.} \sim Y_{cp} = 0, Z_{cp} = \text{WL } 55$$

Landing gear(s) door loading is illustrated in Figures 4.79 through 4.81.

4.9.3 Thrust Spoiler Loads

The thrust spoiler loads were assumed directed normal to the apparent deflection plane and coincident with the area centroid. Each thrust spoiler sustains, in addition to a steady-state load, a differential amount due to 0.5% RPM fluctuation which are as follows:

$$1035 \pm 27 \text{ lbs.}$$

4.9.4 Wing-Fan Closure Door Loads

The critical door loading for conventional flight is illustrated in Figure 4.82. This condition corresponded to maneuvering flight designation F-1 ($M = .8$, $q \approx 850 \text{ psf}$, $n_z = 4$).

The critical door loading for the VTOL configuration was found with respect to the following condition:

$$V = 110 \text{ KTS, } 40 \text{ ft/sec. lateral gust } (\beta = 12^\circ)$$

$$\text{MAX, Fan Thrust, } \beta_s = 13^\circ, 40^\circ < \beta_v < 50^\circ$$

Corresponding loads are:

	<u>YAW LEFT</u>		<u>YAW RIGHT</u>	
	<u>Outbd.</u>	<u>Inbd.</u>	<u>Outbd.</u>	<u>Inbd.</u>
Hinge Moment, in-lbs. (+ opening)	-5,500	7,000	10,000	-10,000
Twisting Moment, in-lbs. (+ leading-edge outbd.)	12,500	10,000	-6,500	-6,500
Side Force, lbs. (+ F_y causes + HM)	-800	500	600	-800

LOCAL LOAD, lbs/in

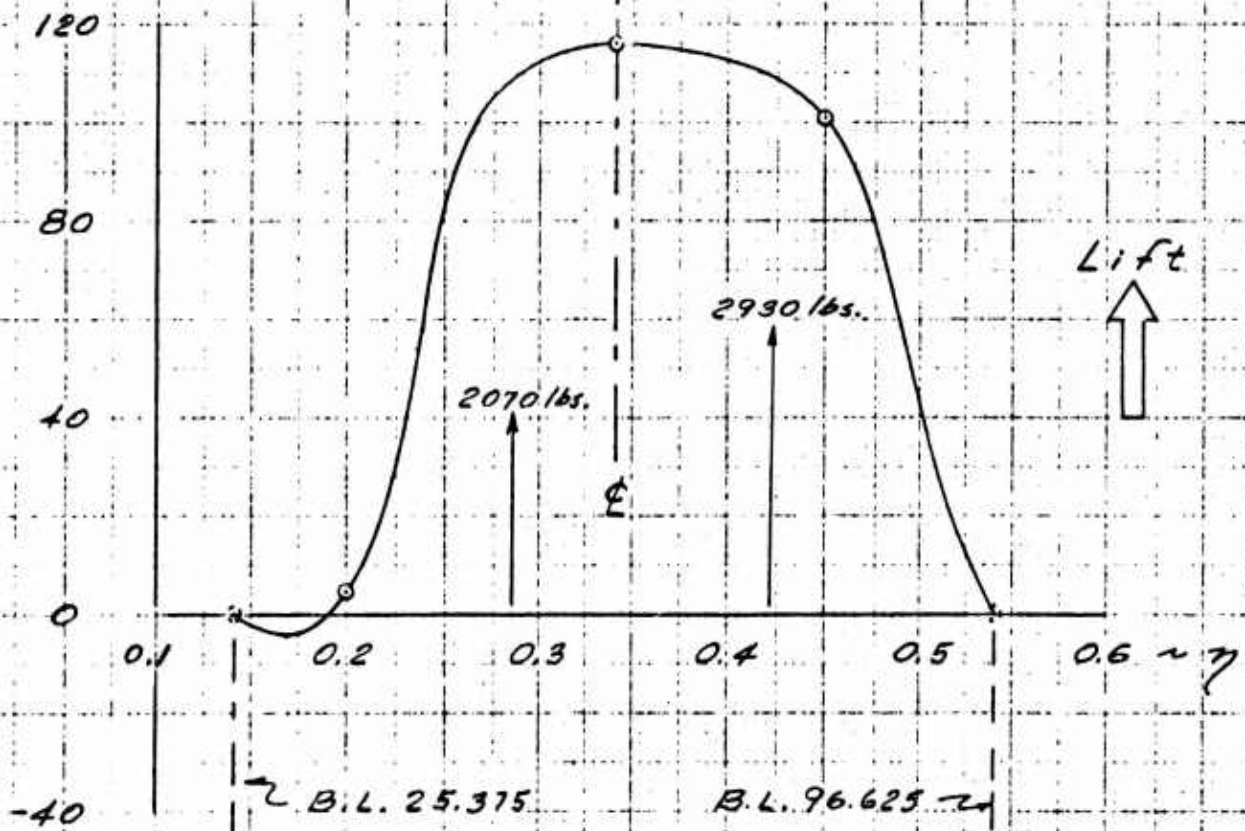

Figure 4.82 Design Wing - Fan Door Loading, Conventional Flight

4.9.5 Aircraft Support Pad Loads

To provide facility for jacking the airplane or suspension during full-scale wind-tunnel test, three support pads were provided. Design (limit) reaction loads at each of two wing pads and one aft fuselage pad are as follows:

Wing Reactions

$$R_x = \pm 3000 \text{ lbs. , fore or aft}$$

$$R_y = \pm 2100 \text{ lbs. , lateral}$$

$$R_z = 6000 \text{ lbs. down, or 7000 lbs. up}$$

Fuselage Reactions

$$R_H = 1000 \text{ lbs. , omni-directional horizontal component}$$

$$R_Z = 3000 \text{ lbs. down, or 2500 lbs. up}$$

4.9.6 Control Surface Loads

Aileron, elevator and rudder control surfaces were designed to the loading shown in Figures 4.83 through 4.85 on the basis of maximum pilot effort inputs.

Design flap load in terms of a developed hinge moment for the condition of full flaps (45°) at 180 KEAS was 9420 in-lbs. (max. per side).

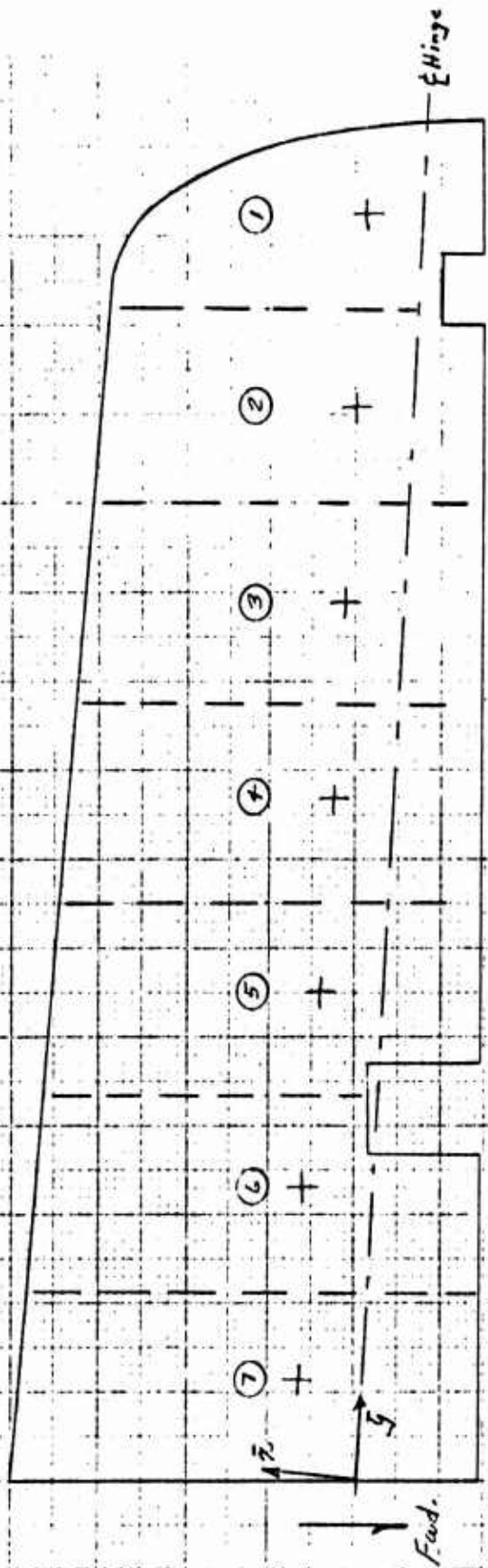

Panel No.	Load, f , lbs.	\bar{x}_{cp1} , in.	$f \cdot \bar{x}_{cp1}$	\bar{y}_{cp2} , in.
①	230	3.0	702	71.3
②	440	3.2	1408	60.3
③	465	3.3	1534.5	47.3
④	480	3.5	1680	38.3
⑤	480	3.6	1728	27.3
⑥	485	4.0	1940	16.3
⑦	545	3.7	2016.5	5.3
	3125		14,009	

Note: Based on 4000 lbs. hydra. act. force

Figure 4.83 Aileron Design Loading

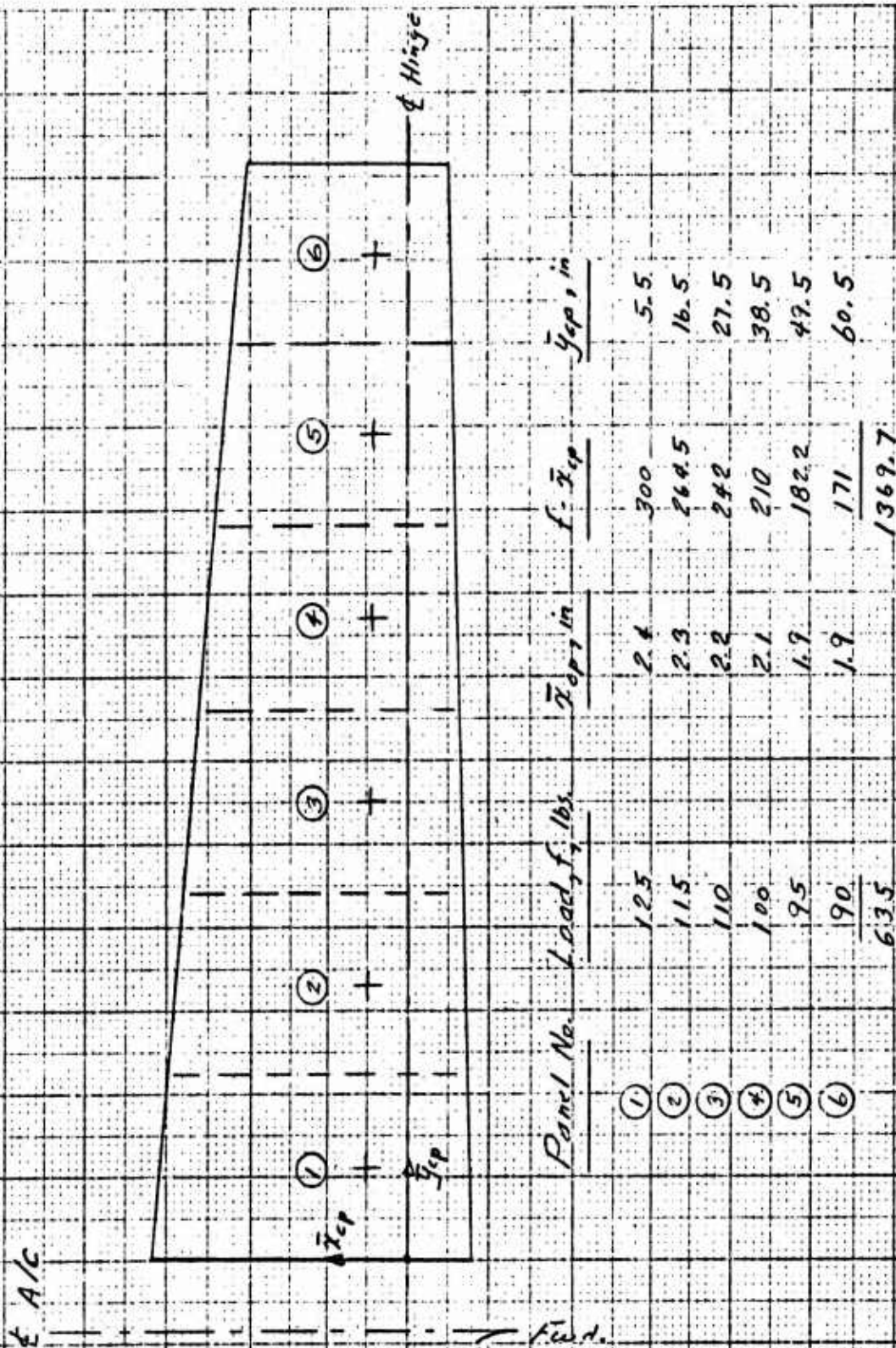

Note: Based on 200 lb stick force

Figure 4.84 Elevator Design Loading

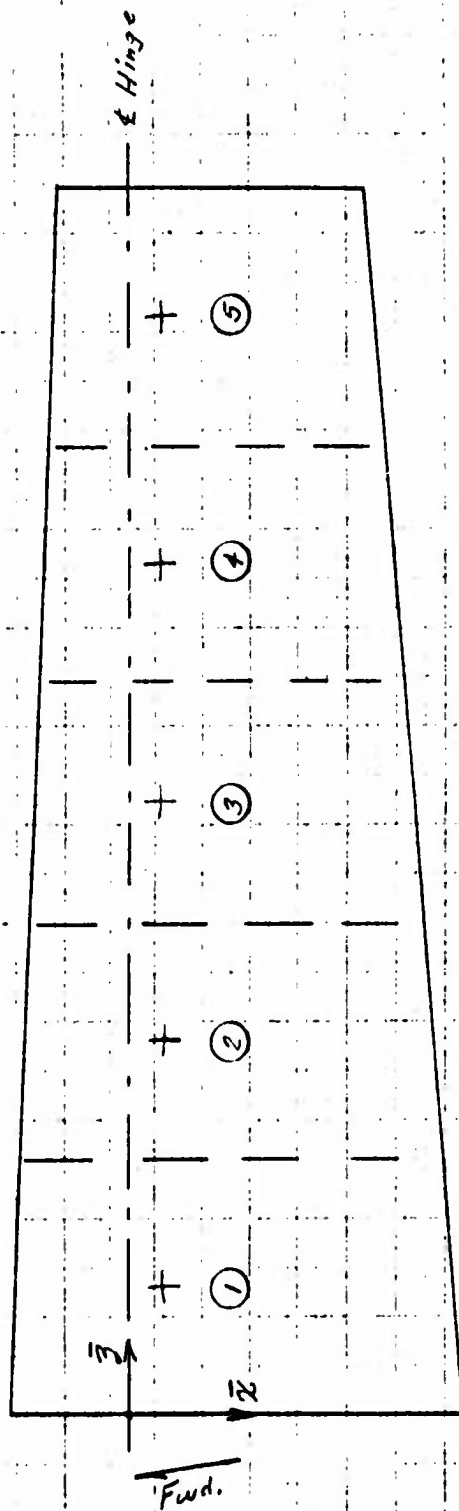

Panel No.	Load, f_s , lbs.	\bar{r}_{cp} , in.	$f \cdot \bar{r}_{cp}$	\bar{r}_{cp} , in.
①	300	1.75	585	6.5
②	270	1.8	486	19.0
③	250	1.7	425	31.0
④	235	1.6	375	43.0
⑤	235	1.5	353	49.5
	1290		2225	

Note: Based on 300 lb pedal force

Figure 4.85 Rudder Design Loading

4.9.7 Wing Drag Loads

Section 4.4 provided, by means of panel point forces, net wing loading perpendicular to the wing chord plane. For each exposed semi-wing span, "drag" loads (parallel to wing chord plane) were calculated for two conditions as follows:

Condition F-1 (PLAA)

1057 lbs. (viscous)

1417 lbs. (press.)

2474 lbs. (net aero.)

Condition F-13 (PHAA)

-2000 lbs., fwd. (net aero.)

5.0 CONCLUSION AND RECOMMENDATIONS

All XV-5A structural loading conditions have been evaluated and shown commensurate with inherent structural integrity and to comply in scope and with requirements set forth by the Structural Design Criteria, ... except for rolling pull-out maneuvers which produce, in combination, vertical and lateral load factors in excess of 2.5 and 0.8, respectively.

It is recommended that the XV-5A Structural Design Criteria be revised to reflect actual strength capability and thus eliminate conflict with the present report through implicating erroneous capability, and to furthermore advise all appropriate parties as to flight boundaries deemed safe by this report.

6.0 REFERENCES

1. Airplane Structural Design Criteria, General Electric Co., Report Number 122, August 20, 1962
2. Wind Tunnel Test Report Lift Fan - Powered Scale Model, General Electric Co., Report Number 137, November, 1963.
3. Wind Tunnel Test Report Conventional Model, Volumes I and II, General Electric Co., Report Number 141, January, 1964.
4. Wind Tunnel Test Report Conventional Model, Volume III, General Electric Co., Report Number 141, January, 1964.
5. Anon: Airplane Strength and Rigidity, Landplane Landing and Ground Handling Loads, Military Specification, MIL-A-8862 (ASG), 18 May 1960.
6. Landing Gear Criteria, Ground Loads and Reactions, General Electric Co., Report Number 131, October, 1963.
7. DeYoung et al.: Theoretical Symmetrical Span Loading at Subsonic Speeds For Wings Having Arbitrary Plan Form, National Advisory Committee For Aeronautics, Report No. 921, 1948.
8. Hoerner, S.F.: Fluid Dynamic Drag, Published by the Author, 1958.
9. Koenig, D.G.: Low-Speed Tests of Semispan-Wing Models at Angles of Attack From 0° To 180°, National Aeronautics and Space Administration, NASA MEMO 2-27-59A, April, 1959.