

U. S. NAVAL SUPPLY RESEARCH & DEVELOPMENT FACILITY  
U. S. NAVAL SUPPLY DEPOT  
BAYONNE, NEW JERSEY

PALLET BOLT DEVELOPMENT

SEIR - 007

Distribution of this document  
is unlimited  
1 JANUARY 1950

AD648361

①

ARCHIVE COPY

**Best  
Available  
Copy**

# PALLET - BOLT

## DEVELOPMENT

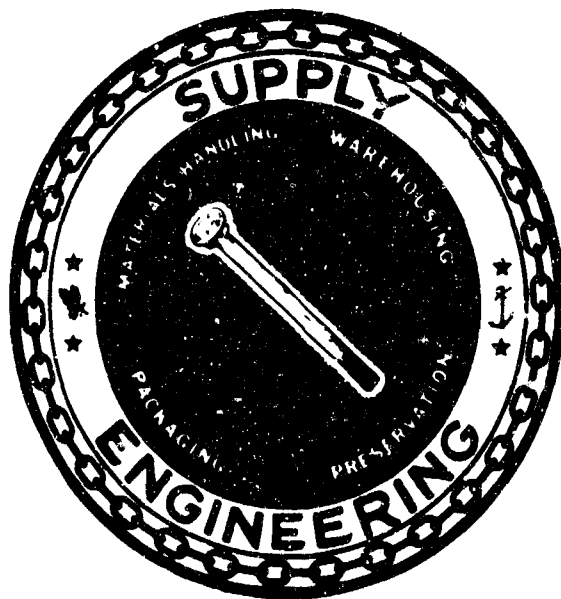

Distribution of this document  
is unlimited.

D D C  
RECEIVED  
MAR 16 1967  
B

SEDR - 007  
1 Jan. 1950

U.S. Naval Supply Research & Development Facility  
Bayonne, New Jersey

U. S. NAVAL SUPPLY  
RESEARCH & DEVELOPMENT FACILITY  
BAYONNE, NEW JERSEY

"PALLET BOLT DEVELOPMENT"

Supply Engineering Division Report No. 007

Sub-title under

Project No. NT-003-001

- AUTHORIZATION:** ChBuSanda ltr dtd 15 Oct 1945 to OinC NSOTC (now NSRADF), file No. L8-2/NT4-22 (FSX4-KTW)frh N6/JJ.
- PURPOSE:** To develop a bolt and nut assembly for the New Military Standard 40" x 48" Wood Pallet, and to test various bolt designs in order that authoritative information be available for recommendations for pallet bolt specifications.
- CONCLUSIONS:** Two of the fifteen bolt designs tested were found suitable for pallet construction. A nut design was also found acceptable.
- RECOMMENDATIONS:** It is recommended that additional development be undertaken to determine the optimum design of the two acceptable basic forms, in order that a final choice can be made.

## PALLET DEVELOPMENT

### INTRODUCTION

There are in general use today, two principle means of assembling wooden pallets, namely: nails and bolts. Of the two, nails are the most widely used. However, it is sometimes necessary to employ the less economical but more serviceable bolted means. This is particularly true in cases where ease of assembly of a pallet is a requisite or where the strength advantages offered by bolts must be utilized.

It has been found advisable to implement the *New Military Standard 40" x 46" Wood Pallet* with two sets of specifications; one covering an all nailed construction for general use, and another in which the pallet is assembled by a combination of bolts and nails. The latter form of construction permits disassembly of pallets for unburdened overseas shipment or for pallet resupply when the conservation of shipping space is essential.

In order to simplify assembly and to minimize the number of component parts, it was found practical to nail the transverse boards and some of the top deck boards into a sub-assembly. The remaining parts are combined with the sub-assembly by means of 18 bolts--two at each post location, page 111. The shipping cube of the sub-assembly and other

parts is approximately half that of a completely assembled pallet. It was found that a bolt 5/16" in diameter was sufficiently strong.

In testing bolted pallets, one serious deficiency was encountered repeatedly. If a bolt loosened, it was found exceedingly difficult, if not impossible, to retighten it. When a torque was applied to the nut, the bolt would turn freely. The presence of any rust or corrosion or the deformation of any threads aggravated this condition.

Another fault of the bolts commonly used in pallet construction was the necessity of deep counter-boring in order to effect a flush head. This counter-boring materially weakened the member in which it was done and also resulted in a depression wherein water would collect and accelerate rusting of the bolt or rotting of the wood around it.

It was determined that the bolt and nut to be used in a standard military pallet must fulfill the following requirements:

1. For economic considerations, both bolt and nut must be adaptable to present day production line manufacture.
2. The bolt head or shank must be so designed that it will lock into the wood suffi-

ciently to resist the torque necessary to tighten or loosen the nut at any time during the life of the pallet.

3. The bolt and nut must be of such a design that when the bolt is pulled up tightly in the pallet assembly, the heads of both nut and bolt must be flush with the wood surface without resorting to excessive counter-boring.

4. The above functions should be accomplished preferably without the use of any accessories, viz., washers.

A survey of bolt manufacturers disclosed a number of bolt designs which might be adapted to pallet use. The manufacturers furnished samples of their products for experimental purposes and several of the companies further cooperated by making new designs in an attempt to overcome known deficiencies.

It was found that there was a commercially available nut that most nearly fulfilled the requirements. Certain modifications were made to this nut in order to obtain maximum results. This modified version has since been incorporated in the standards of the manufacturer and was used in these tests. A photograph of this nut appears in Figure 5.

After extensive study, the *Supply Engineering Division of the U. S. Naval Supply Research and Development Facility* developed several bolt designs. These bolts are designated in this report as Series A and may be seen, along with those obtained from commercial outlets on page 1.

It is the purpose of this report to present the developmental work accomplished in the design of a suitable pallet bolt, and to show the results of the various tests conducted. Included are pertinent conclusions and recommendations.

$\frac{5}{16}$ " DIA. BOLT & NUT  
ASSEM. - 18 REQ'D

FLUSH HEAD HEX. SOCKET  
NUT FORM FROM #15 GA.  
FERROUS ALLOY

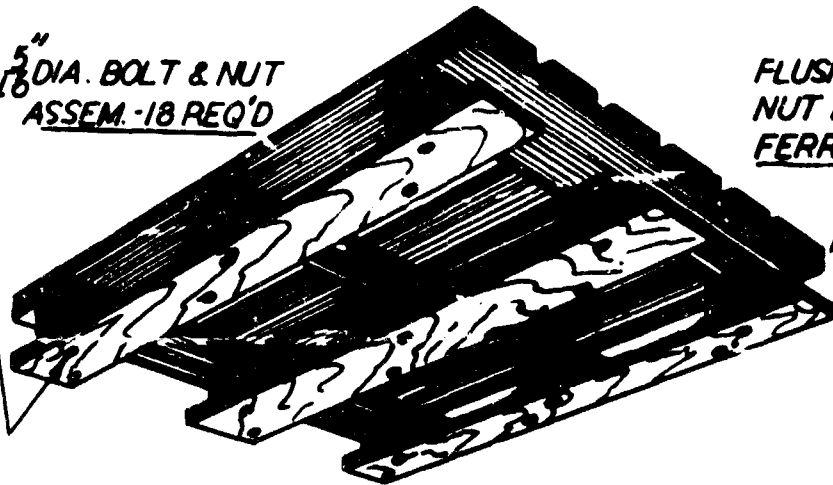

$\frac{5}{16}$ " HEX.  $\frac{1}{4}$ "  
DEEP



40" X 48" NAVY STD. WOOD PALLET  
BOLTED CONSTRUCTION



BOLT HEAD OR SHANK TO  
INITIATE & SUSTAIN ADE-  
QUATE LOCKING OF BOLT  
IN WOOD WHEN NUT IS  
TURNED

$\frac{3}{8}$ " DRILL 18 HOLES THRU  
PALLET ASSEMBLY &  
C'BORE AS REQUIRED  
FOR  $\frac{5}{16}$ " DIA. BOLT & NUT  
SEE TYPICAL SECTION

TYPICAL  
BOLT SECTION

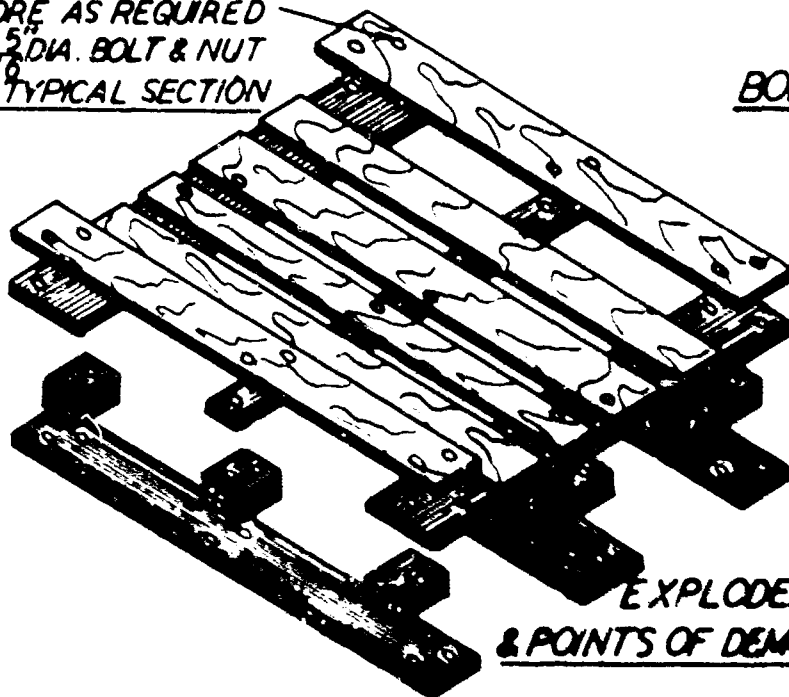

EXPLODED VIEW  
& POINTS OF DEMOUNTABILITY

REQUIRED DETAILS FOR BOLTED PALLET

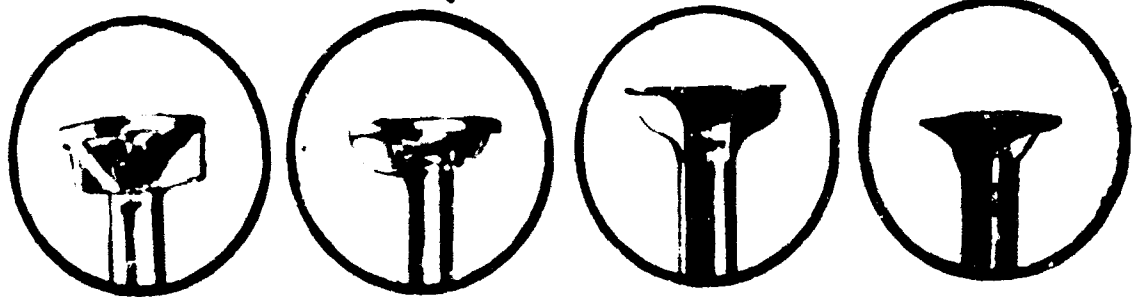

A

A1

A2

B



B1

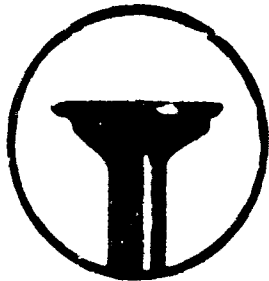

B2

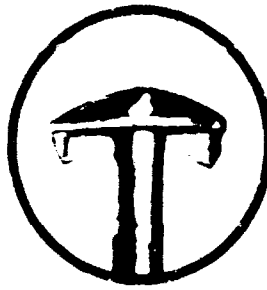

C

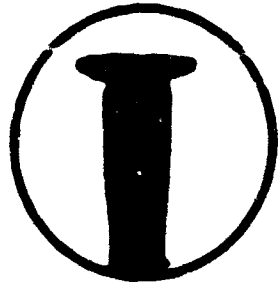

D

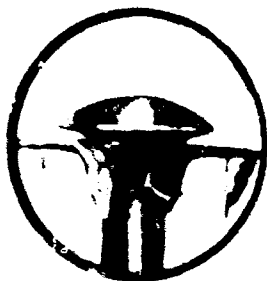

E

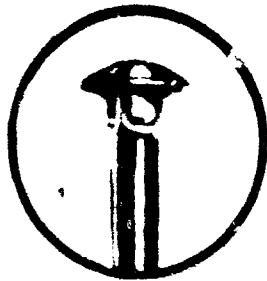

E1

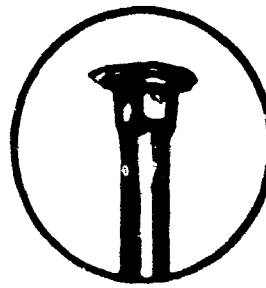

E2

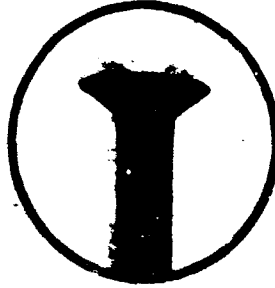

E3

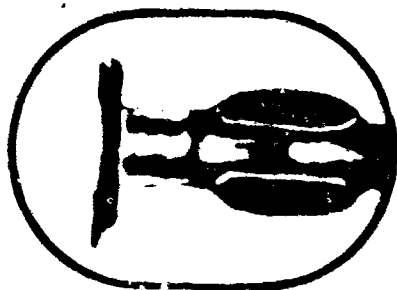

F

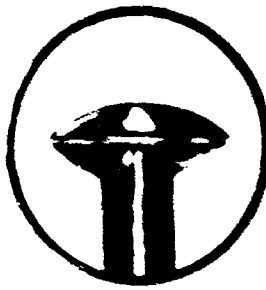

G

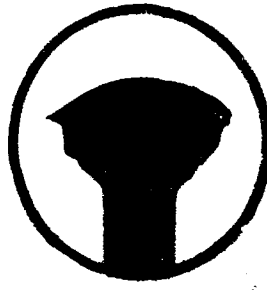

G1

DESIGNS OF BOLTS TESTED  
APPROX. FULL SIZE

**PALLET BOLT DEVELOPMENT  
TEST MATERIAL AND EQUIPMENT**

**TEST MATERIAL:**

1. Hardwood block assembly (white oak) simulating a section of the 40" x 48" pallet. Page 4.
2. Softwood block assembly (yellow pine) similar to a section of the 40" x 48" pallet. Page 4.
3. Flush head, hexagon-socket nut; supplied by *United-Carr Fastener Corporation, Cambridge, Massachusetts*. Figure 5.
4. Bolt designs, commercial and others, having the following descriptions:  
(The preceding page shows individual photographs of heads of each bolt tested and may be referred to in conjunction with the following descriptions.)

**TYPE A**

Large conical head with 3 flat radial fins projecting downward from the surface of the conical head. This bolt designed by *Supply Engineering Division* and manufactured at the *Naval Supply Depot, Bayonne, New Jersey*.

**TYPE A1**

Flat head with 3 radial flat fins having a quarter circle profile projecting downward from the underface of the head and integral with the shank. A fillet rounds out the intersection of the shank and the head. This bolt designed by *Supply Engineering Division* and manufactured at the *Naval Supply Depot, Bayonne, New Jersey*.

**TYPE A2**

Thin flat head with beveled edge and 3 tapered radial fins extending downward from the underface of the head. A small fillet rounds out the intersection of the shank and head. This bolt designed by *Supply Engineering Division*, and manufactured by the *Naval Supply Depot, Bayonne, New Jersey*.

**TYPE B**

Thin flat head with beveled edge and four small non-symmetrical fins having a substantially triangular profile placed in the web at the intersection of the shank and the head. Designed and manufactured by the *Lewis Bolt Company, Minneapolis, Minnesota*.

**TYPE B1**

Identical with Type B except that a small rectangular lug has been punched out of and turned downward from the head. Designed and manufactured by *Lewis Bolt Company, Minneapolis, Minnesota*.

**TYPE B2**

Substantially identical with Type A2. Minor dimensional alterations made to accommodate manufacturing processes. Designed by *Supply Engineering Division*, and manufactured by *Lewis Bolt Company, Minneapolis, Minnesota*.

**TYPE C**

A button headed bolt having two lugs punched out of and extended downward from the edge of the head. Supplied by *Roll-Rite Corporation*.

Oakland, California.

#### TYPE D

A flat head bolt having a portion of the shank just below the head enlarged, tapered, and splined. Edge of head beveled. Supplied by *Lamson Sessions Company, Cleveland, Ohio.*

#### TYPE E

Combination of standard square neck carriage bolt, button head, and four pronged washer having a square hole in the center to accommodate the square neck of the carriage bolt and having four flat triangular lugs punched out of and extending downward from the washer. Designed and manufactured by *United-Carr Fastener Corporation, Cambridge, Massachusetts.*

#### TYPE E1

Standard square neck button head carriage bolt manufactured by *Lewis Bolt Company, Minneapolis, Minnesota.*

#### TYPE E2

Flat head square neck carriage bolt. Edge of head beveled. Manufactured by *MacLean-Fogg Company, Chicago, Illinois.*

#### TYPE E3

Square neck carriage bolt having a conical or counter-sunk head. Manufactured by *Lewis Bolt Company, Minneapolis, Minnesota.*

#### TYPE F

Thin beveled headed bolt with two radial fin diametrically opposed

and forged from a section of the shank slightly below the head. Designed and manufactured by *MacLean-Fogg Company, Chicago, Illinois.*

#### TYPE G

Button head bolt with two tapered radial fins, substantially triangular in profile and symmetrical, extending downward from the underface of the head and integral with the shaft. Manufactured by *Wassner Bolt Company, Cleveland, Ohio.*

#### TYPE G1

Button head bolt with two thick radial fins extending downward from the overface of the head and integral with the shaft, the profile being substantially rectangular with the lower corners beveled off. Manufactured by *Wassner Bolt Company, Cleveland, Ohio.*

#### TEST EQUIPMENT

1. Torque wrenches (Manufacturer: *Snap-On Tool Corporation, Kenosha, Wisconsin*) with the following capacities:

- (a) 0 to 30 inch-lbs. in 1 inch-lb. increments
- (b) 0 to 150 inch-lbs. in 5 inch-lb. increments
- (c) 0 to 600 inch-lbs. in 20 inch-lb. increments
- (d) 0 to 150 foot-lbs. in 5 foot-lb. increments

2. Special tools to facilitate testing, shown on pages 4(a) and 4(b).

# TEST BLOCKS FOR PALLET BOLTS

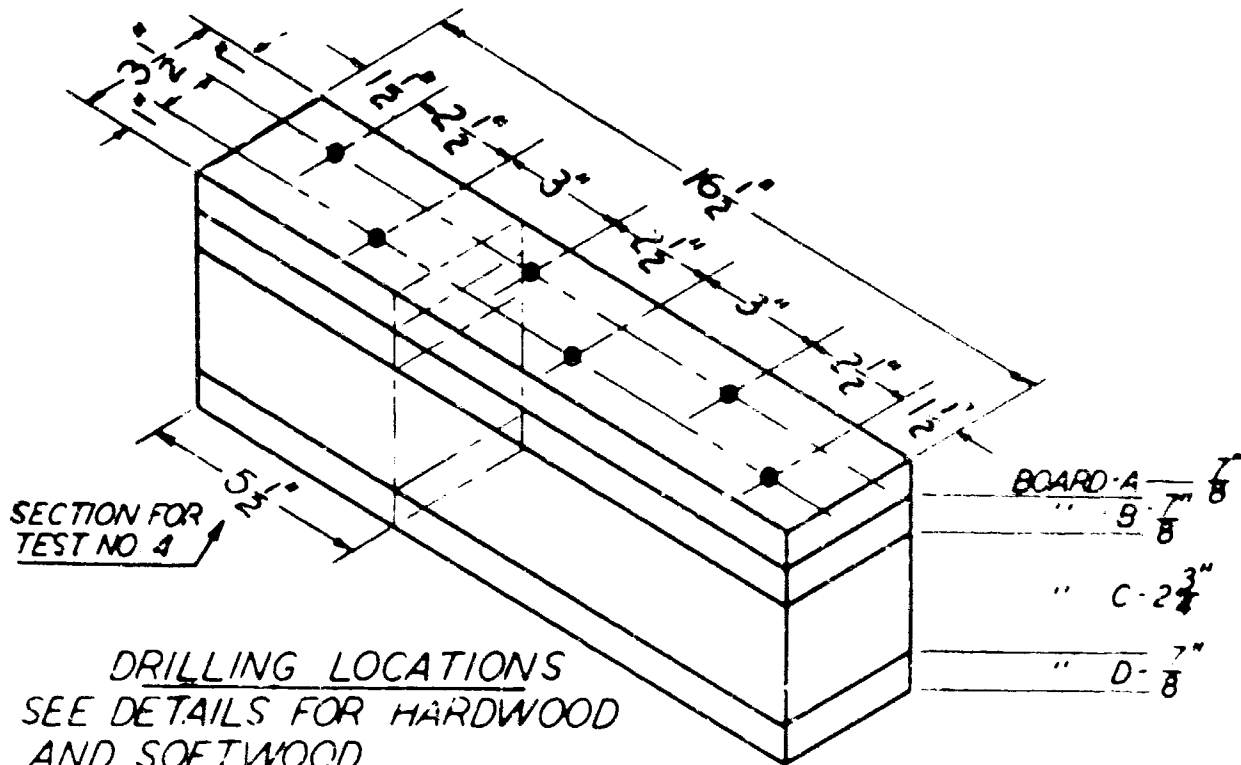

DRILLING LOCATIONS  
 SEE DETAILS FOR HARDWOOD  
 AND SOFTWOOD

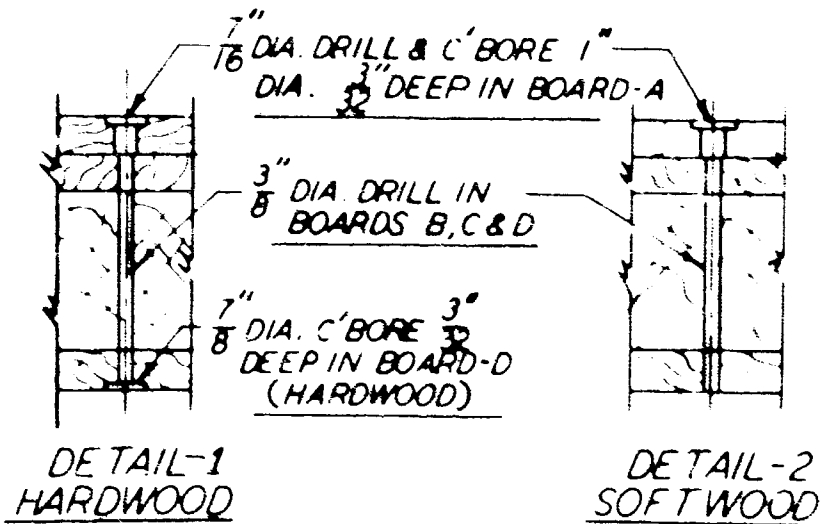

## DRILLING DETAILS

NOTE:  
 FOR HARDWOOD USE OAK  
 FOR SOFTWOOD USE YELLOW PINE

SED-SK-190

**SPECIAL TOOLS  
FOR  
BOLT TORQUE TEST**

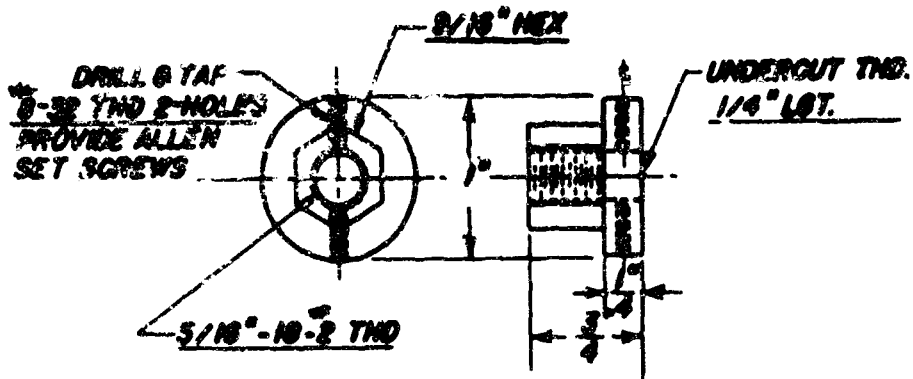

**SPECIAL TENSION TOOL  
MATL HARDENED STEEL**

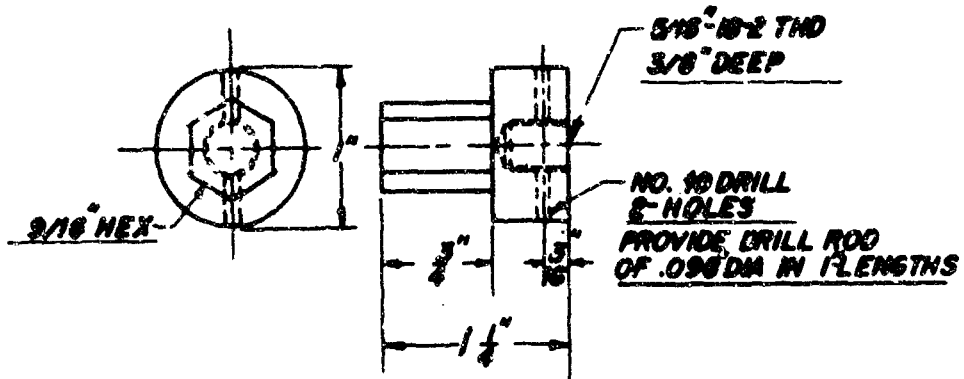

**SPECIAL TURNING TOOL  
MATL HARDENED STEEL**

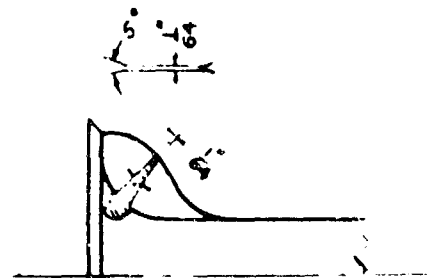
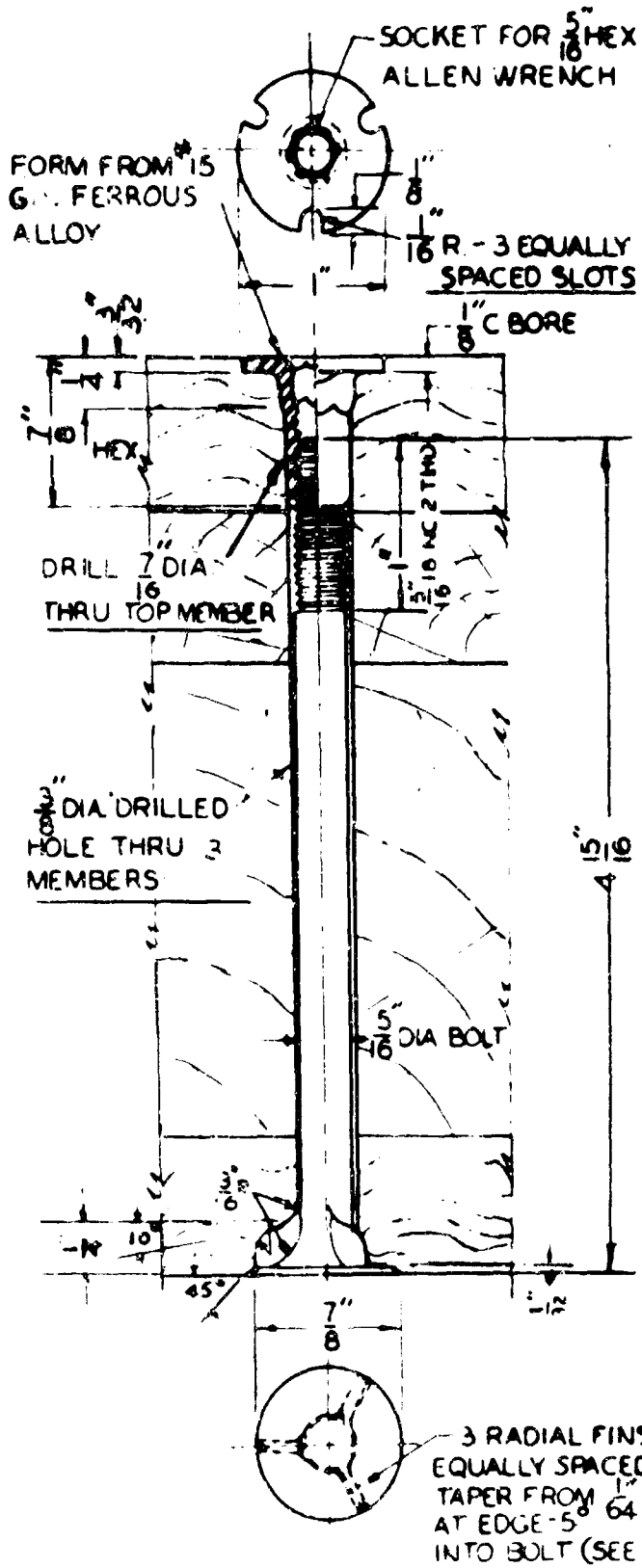

ENLARGED FIN DETAIL

FUNCTIONAL BOLT & NUT DESIGN  
FOR PALLETS  
TYPE-A2

## TEST SCHEDULE

**TEST NO. 1** - Maximum Resistance of the bolt to be Turned in Wood. (Hardwood and Softwood).

**Conditions:**

In order to allow accessibility to the bolt thread, for the special tools used in this test, the top board of the block assembly, page 4, and the nut should not be used. The bolt shall be drawn tightly into the remaining members of the test block with the special tool shown on page 4a. The special tool shall then be backed off and retightened until 15" lbs. of torque is reached. The tool shall then be secured to the bolt by the set screws. The second special tool, shown on page 4a, containing a blind threaded hole, shall be turned onto the bolt until the bolt hits the thread bottom. A torque wrench shall then be used to forcibly turn this tool and the maximum force resistance by the bolt before turning in the wood or breaking shall be recorded, Figure 1. Readings shall be taken in both hardwood and softwood blocks. Where the lugs, fins, or other holding means are symmetrical to a longitudinal axial plane of the bolt, readings shall be taken only in the clockwise direction; where the holding means are not symmetrical, readings shall be taken in both the clockwise and counter-clockwise directions.

**TEST NO. 2** - Torque Required to back

Nut off bolt.

**Conditions:**

Bolts shall be placed in test blocks and a nut turned on. The nut shall then be tightened until the bolt head is drawn into the wood and the components of the block are tightly drawn together. A torque wrench shall then be used to back the nut off the bolt, and the maximum torque incurred shall be recorded. The ability of the bolt head to withstand this counter-clockwise torque shall be noted.

**TEST NO. 3** - Determination of the effects of weather and the maximum torque necessary to remove the nut from the bolt when the two are rusted. The resistance of the bolt to turning shall also be noted.

**Conditions:**

The bolt shall be driven up and tightened into the test blocks with the nut of Figure 5, until the head of the bolt is drawn into the wood and the components of the block are tightly drawn together. The blocks shall then be cycled in a weather conditioning chamber, during which time the bolt and nut should accumulate severe rust. As an alternative, the block assembly shall be subjected to alternate 24 hour salt water immersions and drying periods out of doors until a severe rusting is obtained. A torque wrench shall then be used to determine the amount of torque necessary to disengage the

nut from the bolt and the ability of the bolt to resist turning in the wood shall be noted. This procedure shall be followed using both hardwood and softwood blocks.

**TEST NO. 4** - Torque required to tighten bolt into drilled hole of pallet post assembly (Hardwood and Softwood).

*Conditions:*

Bolts shall be pushed up through the test blocks, page 4, until initial turning on of a nut is possible. A torque wrench shall then

be used to determine the torque necessary to draw the bolt head into the wood and to establish the torque required for final tightening. The torque for final tightening shall be that torque at which the underface of the bolt head is firmly compressing the wood and the components of the block are tightly and adequately drawn together. This procedure shall be followed with each bolt design in both hardwood and softwood blocks.

TORQUE REQUIRED TO CAUSE BOLT HEAD TO SLIP OR FAIL (INCH-POUNDS)												
BOLT TYPE	HARDWOOD						SOFTWOOD					
	CLOCKWISE			C' CLOCKWISE			CLOCKWISE			C' CLOCKWISE		
	MAX.	MIN.	AVG.	MAX.	MIN.	AVG.	MAX.	MIN.	AVG.	MAX.	MIN.	AVG.
A	-	190+	-	-	-	-	-	185+	-	-	-	-
A1	-	190+	-	-	-	-	140	140	140	-	-	-
A2	-	205+	-	-	-	-	-	200	-	-	-	-
B	105	95	107	105	95	98	90	80	85	-	-	-
B1	150	140	145	110	85	97	120	115	117	-	-	-
B2	160	140	153	-	-	-	170	140	155	-	-	-
C	150	150	150	-	-	-	140	140	140	-	-	-
D	75	50	62	-	-	-	45	35	38	-	-	-
E	-	190+	-	-	190+	-	-	190+	-	-	-	-
E1	85	60	70	-	-	-	50	30	39	-	-	-
E2	55	40	48	-	-	-	45	40	42	-	-	-
E3	55	40	49	-	-	-	45	35	39	-	-	-
F	200	190	194	-	-	-	200	160	180	-	-	-
G	125	100	115	-	-	-	-	-	-	-	-	-
G1	185	145	162	-	-	-	160	140	152	-	-	-
ALL	-	-	125	-	-	-	-	-	113	-	-	-

+ BOLT SHANK FAILED FIRST.

TABLE I - SUMMARY OF DATA FROM TEST I.

BOLT TYPE	TEST 2 REMOVAL OF NUT IMMEDIATELY AFTER TIGHTENING				TEST 3 REMOVAL OF NUT AFTER WEATHERING			
	HARDWOOD		SOFTWOOD		HARDWOOD		SOFTWOOD	
	POSSIBLE	TORQUE	POSSIBLE	TORQUE	POSSIBLE	TORQUE	POSSIBLE	TORQUE
A	YES	180	YES	240	TESTING DISCONTINUED			
A1	YES	310	YES	210	"			
A2	YES	90	YES	100	YES	370	YES	200
B	NO	75	NO	75	NO	240	NO	95
B1	YES	80	YES	75	NO	300	NO	190
B2	YES	80	YES	100	YES	330	YES	300
C	YES	130	YES	180	YES	300		
D	YES	100	---	---	NO	290	---	---
E	YES	120	YES	130	YES	340	YES	330
E1	YES	75	YES	80	---	---	---	---
E2	---	---	YES	100	NO	300		
E3	YES	90	YES	85			NO	180
F	YES	95	YES	80	YES	360	YE	300
G	---	---	---	---	---	---	---	---
G1	YES	90	YES	115	NO	375	NO	375

\*SEE FIELD DATA SHEET.

TABLE 2 - SUMMARY OF DATA FROM TESTS 2 & 3.

BOLT TYPE	TORQUE REQUIRED TO DRAW HEAD INTO WOOD (IN.-LBS.)						TORQUE REQUIRED FOR FINAL TIGHTENING (IN.-LBS.)					
	HARDWOOD			SOFTWOOD			HARDWOOD			SOFTWOOD		
	MAX.	MIN.	AVG.	MAX.	MIN.	AVG.	MAX.	MIN.	AVG.	MAX.	MIN.	AVG.
A	-	-	-	-	-	-	-	-	-	-	-	-
A1	-	-	100	-	-	-	-	-	100	-	-	-
A2	85	75	82	95	80	90	110	105	107	130	125	128
B	60	80	74	-	-	-	115	80	96	-	-	-
B1	60	50	58	75	75	75	100	85	93	100	90	98
B2	100	95	97	80	80	80	115	100	108	120	120	120
C	-	-	180	-	-	180	-	-	-	-	-	-
D	60	45	50	-	-	-	90	85	98	-	-	-
E	170	160	165	140	130	133	170	160	165	140	130	133
E1	25	15	21	-	-	-	100	90	96	-	-	-
E2	-	-	-	-	-	-	-	-	-	-	-	-
E3	55	30	40	-	-	-	110	95	103	-	-	-
F	-	-	-	-	-	-	100	100	100	95	90	92
G	-	-	-	-	-	-	-	-	-	-	-	-
G1	80	70	75	90	60	74	120	100	113	135	100	118
ALL	-	-	72	-	-	120	-	-	107	-	-	115

\*SEE FIELD DATA SHEET

TABLE 3 - SUMMARY OF DATA FROM TEST 4.

## TEST RESULTS

## DISCUSSION

The several types of commercial carriage or square neck bolts included in the test schedule did not satisfy the functional requirements for pallet construction. When used in an oversized hole, such as is required in wood pallets, the bolt depends solely on the extreme edges of the squared neck in the wood to resist turning. The low values of resistance obtained by Type E1, E2, and E3 bolts make it evident that for this bolt to resist turning in wood, an accessory such as a special washer is needed. The bolt-washer combination, Type F, illustrates an effective means. The washer has a square hole to accept the neck of the bolt and turned-down corner prongs that are forced into the wood. It was found that this device provided a most rigid lock, attaining a strength limited only by the shear strength of the bolt shank. The inadequacy of this assembly, however, is in the fact that excessive counter-boring of the wood is required to house the bolt head, and that the added parts result in complication of assembly with added cost.

It was not possible to secure maximum results with the tapered-splined shank of Type F bolt. Such locking means are effective only when the drilled hole in the wood is identical to the bolt diameter at the threads. The oversized drilled hole needed for ease of pallet assembly permits only a portion of the

spline depth and length to lock in the wood. The low values of resistance obtained with this bolt are comparable to those obtained with the carriage bolts.

The peripheral lug type bolts, B1 and C, disclosed certain serious weaknesses. When attempts were made to draw the bolt into the wood, some of the lugs would either bend back, or under, or chip off, Figure 2. When the lugs could be drawn into the wood, shearing of these lugs occurred at moderate torques. The lugs of these bolts are formed in manufacture by a secondary operation which combines shearing and bending wherein a section of the outer periphery of the bolt head is bent downward parallel to the bolt shank. Because of this operation, the lug is inherently weak, since the metal therein has already been stressed beyond its elastic limit.

Generally, the design that provided the best and most consistent results were those bolts that had webs or fins radially spaced either under the bolt head or on the shank. It was found that the turning resistance of such a bolt was proportional to both the effective area of the fins or webs and the distance from them to the axis of the bolt. Bolt B and G have a small fin area and produced insignificant results as compared to Types A, A1, A2, F and G2, in which the fins were of greater size. A minimum of two and a maximum of four fins were found on

the bolts tested. A tendency toward splitting of the wood was noted when driving the bolts having fins placed diametrically opposite (especially when the fins were aligned with the grain of the wood). Type F bolt, having diametrically opposed fins, on the bolt shank, provided good values of resistance. However, under high torques the fins showed a tendency to shear. Figure 3.

The Type F bolts, as received from the manufacturer, appeared to have had the fins made by performing a secondary shearing and forming operation on a bolt which had been annealed or normalized after forming. It does not appear that the internal stresses caused by the secondary operation had been relieved and this might account for the weakness of the fins. This observed weakness could probably be overcome by a slight alteration in design and by annealing or normalizing after the fins have been formed.

Consistently good test results were observed with Type A2 bolt. This design is a step-down modification of Types A and A1, since it was found that for all practical purposes the latter two bolts were over-designed. Type B2 was a modified, commercially produced model of the prototype A2 which had been modified to accommodate production method limitations. Test results on this type A2 confirm the virtues of the basic design and the possibilities of further modifications to permit easier manufacture.

It was disclosed during Test 1 that when the bolt was able to obtain an initial lock in the wood, there was no appreciable difference in the holding power in either hardwood or softwood.

In Test 3, wherein the test blocks containing the bolts and nuts were subjected to severe rust conditions, Figure 8, it was established that the torque required to back the nut off the bolt, when both are badly rusted, ranged from 280 inch-lbs. to 370 inch-lbs. It was also noted that under these conditions, the resistance of the bolt to turning is increased. This is due to the additional friction between the nut and the wood and the resetting of the wood fibres around the bolt head, caused by the changing conditions of the wood, i.e., shrinkage and swelling. The shearing of the bolt shanks, which occurred at approximately 200 inch-lbs. in Test 1, was resisted more uniformly under the conditions of Test 3 due largely to the distribution of stresses down the entire length of the bolt, and the added frictional forces brought about by the rust. Under the conditions of Test 3, Bolt Type A2 was able to resist a maximum torque of 370 inch-lbs. without breaking or loosening its hold.

In tests wherein the nut was used with the bolt it was noted that this nut fulfilled all of the requirements. For additional details, see Appendix "A".

## RESUME

Most types of commercial bolts are not readily adaptable to pallet construction. Many bolts which are acceptable from strength considerations, have been found unacceptable because of cost, complication of assembly, or the necessity of counter-boring. Inherently greater acceptability is found in bolts which have integral locking means.

Those bolts which have radial fins arranged under the head or on the shank generally have greater "holding power" or resistance to turning in wood. The degree of this resistance is largely governed by the area and shape of the fins and their location with respect to the longitudinal axis of the bolt. A definite tendency to cause splitting of the wood occurs where fins are diametrically opposed.

Where a bolt is able to provide a good initial lock in wood, there is no appreciable difference between the holding power in hardwood or in softwood. Therefore, only a single design need be specified for either hardwood or softwood.

The high torques required to remove a nut from its bolt when the two are badly rusted, indicates that only those bolts whose resistance to turning was limited solely by the shear strength of the shank in Test 1 would adequately fulfill the functions required in pallet construction.

Only two of the bolts tested pre-

sented a resistance to turning limited only by shear strength of the shanks; they were Types A2 and F.

Although the fins of Type F were not uniformly strong and occasionally would shear at high torques, it is believed that this condition could be overcome by changing the manufacturing technique.

A modification of prototype bolt A2 which can successfully be manufactured by a cold forging process will possess the optimum strength and economy necessary for pallet construction.

In view of the foregoing results of testing the following recommendations are made:

1. *It is recommended that bolts containing the basic designs of Types A2 and F be considered for bolt specifications for the New Military Standard 40" x 48" Wood Pallet.*

2. *It is further recommended that the following investigations be made, and that the final choice between the two types (A2 and F) be based on the results thereof:*

- (a) *The modifications required to make Type A2 adaptable to commercial cold forging processes be determined, and that bolts embodying such modifications and manufactured by those processes be evaluated for strength. This work should be done in close*

cooperation with competent bolt manufacturers.

(b) The strengthening of the *l* of Type *F* be investigated and that bolts containing any changes the manufacturer

may make be evaluated for strength.

3. It is also recommended that the nut used in these tests be accepted for use in the specifications for bolted pallets.

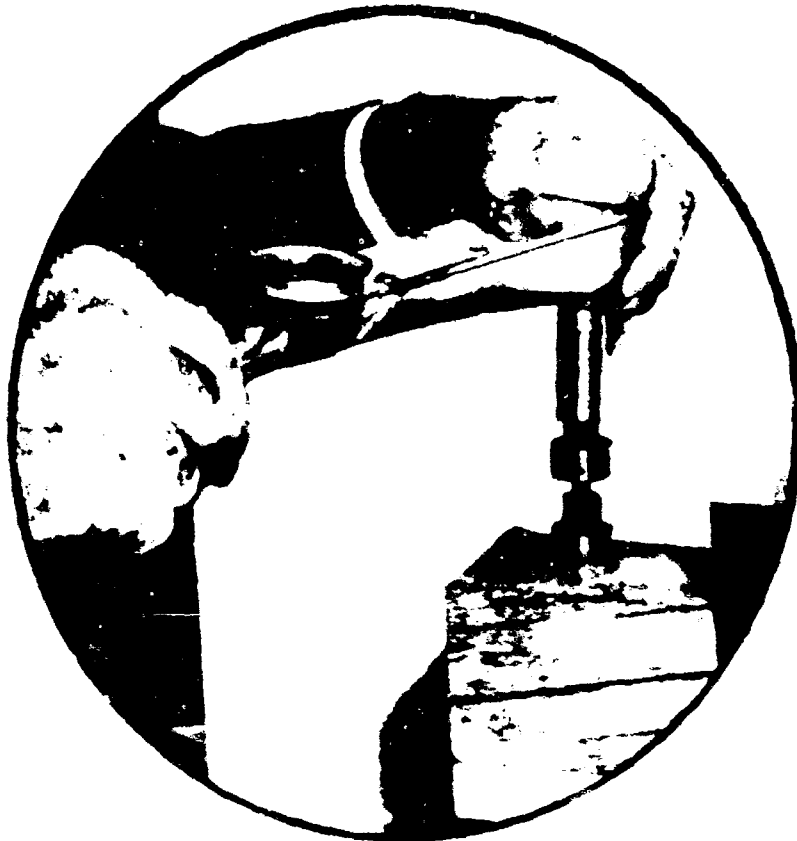

FIG 1 CONDITIONS OF TEST NO 1 BOLTS ARE DRAWN UP INTO THE WOOD BLOCK ASSEMBLY. TENSION IS THEN APPLIED TO THE BOLT BY SPECIAL NUT. SECOND SPECIAL NUT & TORQUE WRENCH ARE USED TO ATTEMPT TO TURN BOLT IN WOOD.

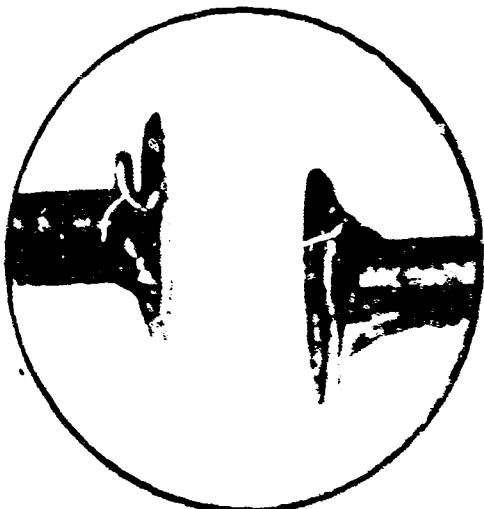

FIG 2 DAMAGE TO TYPE B BOLT FROM TEST AT RELATIVELY HIGH TORQUE



FIG 3 DAMAGE TO TYPE F BOLT FROM TEST. FINS ON SHANK FORMED AT RELATIVELY HIGH TORQUE



A-2



B

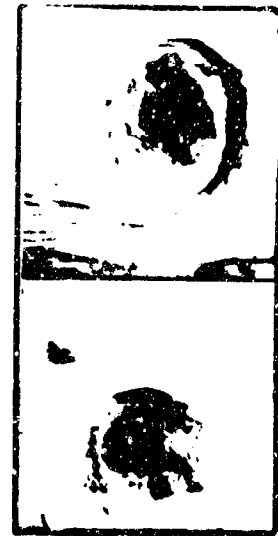

B-1



B-2

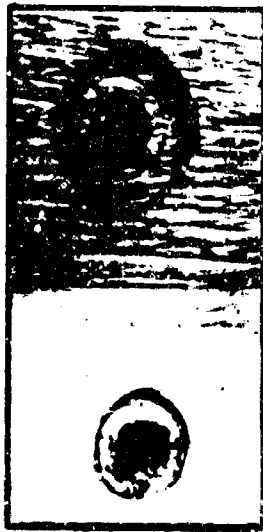

F



G-1



E

FIG. 4 - TYPICAL IMPRESSIONS AND DAMAGES CAUSED BY BOLTS IN BOTH HARDWOOD (UPPER) AND SOFTWOOD (LOWER) BLOCKS IN TEST NO. 1.

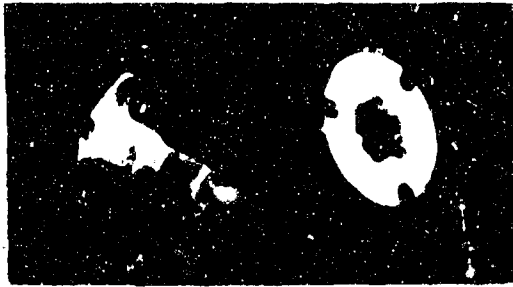

FIG. 5 - FLUSH TYPE NUT  
FOUND ACCEPTABLE FOR  
PALLET CONSTRUCTION.

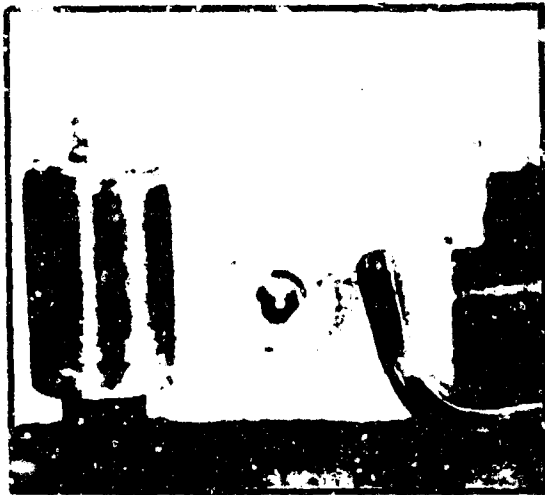

FIG. 6 - NUT IN PLACE SHOW-  
ING FLUSH FACE AND TWO OF  
THE MEANS FOR TIGHTENING.

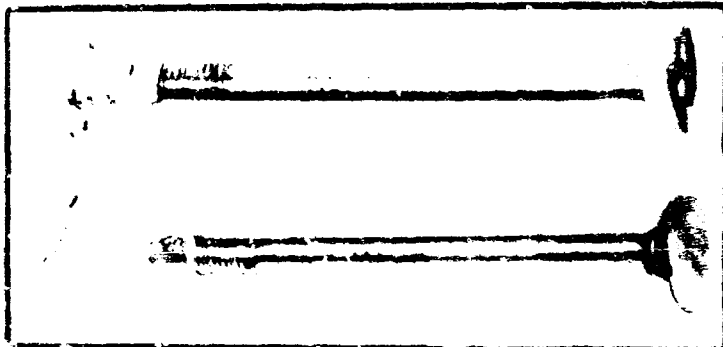

FIG. 7 - DESTRUCTIVE TESTING SHOWED  
NUT ADEQUATE. SHEARING STRENGTH  
EXCEEDS 300 IN.-LBS.



FIG. 8 - TEST BLOCKS AND BOLTS PREPARED FOR TEST 3. ALTERNATE SALT WATER DIPS AND DRYING PERIODS PRODUCED SEVERE RUST CONDITIONS.

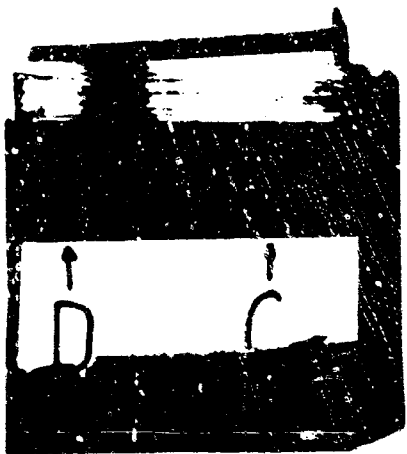

FIG. 9

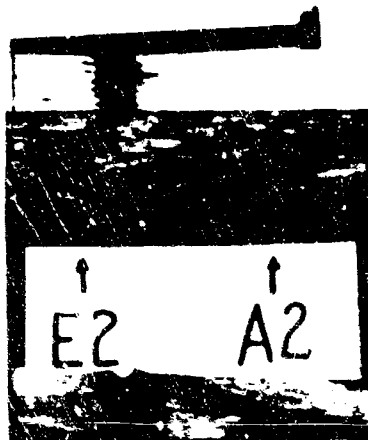

FIG. 10

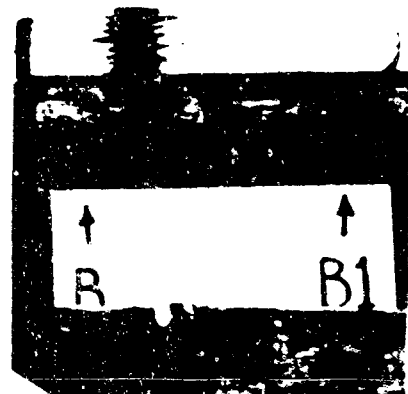
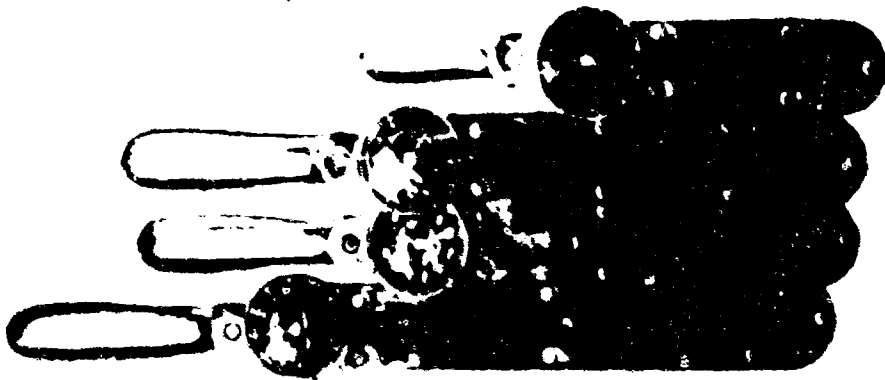

FIG. 11

REPRESENTATIVE RESULTS OF TEST 4. WHERE BOLTS COULD NOT BE REMOVED THEY ARE SHOWN ON TOP OF THEIR RESPECTIVE BLOCKS. BOARD WAS SPLIT TO SHOW OTHER BOLT HEADS.



TORQUE  
WRENCHES



ALLEN WRENCHES



SOCKET WRENCHES



SPANNER WRENCH



TORQUE TOOL



TENSION TOOL

TOOLS USED  
IN THE  
TESTS





BOLT TYPE	TEST NO. 1				TEST NO. 2		TEST NO. 3		TEST NO. 4			
	TORQUE REQUIRED TO CLAMP BOLT HEAD TO FLIP OR FALL (100 - LBS.)				TORQUE REQUIRED TO BACK WRT OFF HEAD (100 - LBS.)		TORQUE REQUIRED TO BACK WRT OFF AFTER WEATHERING (100 - LBS.)		TORQUE REQUIRED FOR BOLT HEAD INTO HOOD (100 - LBS.)		TORQUE REQUIRED FOR STAKE TIGHTENING (100 - LBS.)	
	BARWOOD	CLACKING	CLACKING	SOFTWOOD	BARWOOD	SOFTWOOD	BARWOOD	SOFTWOOD	BARWOOD	SOFTWOOD	BARWOOD	SOFTWOOD
A2	1	200	-	200	75	95	370	280	85	80	105	125
A2	2	205	-	195	75	100			75	95	105	130
A2	3	195	-	190	80	-			80	-	105	-
A2	4	200	-	200	85	-			80	-	105	-
A2	5	195	-	195	90	-			85	-	119	-
A2	6	205	-	200	80	-			85	-	119	-

NOTE: Bolt sheared before head turned

Field Data Sheet  
 PALLET BOLT DEVELOPMENT  
 Bolt Type  
 A2

SUPPLY ENG. DIV.  
 U.S.N.S.R. & F.  
 BAYONNE, N. J.

Date: 11/1/49  
 Rec'd by: N. Toscano

BOLT TYPE	TEST NO. 1 TORQUE REQUIRED TO CARESS BOLT HEAD TO SLIP OR FAIL (114.-LBS.)			TEST NO. 2 TORQUE REQUIRED TO BACK OUT OFF BOLT (114.-LBS.)		TEST NO. 3 TORQUE REQUIRED TO MAKE NUT OFF AFTER BEATING (114.-LBS.)		TEST NO. 4 TORQUE REQUIRED FOR FINAL TIGHTENING (114.-LBS.)		
	HARDWOOD		SOFTWOOD	HARDWOOD	SOFTWOOD	HARDWOOD	SOFTWOOD	HARDWOOD	SOFTWOOD	SOFTWOOD
	CLOCKWISE	COUNTER-CLOCKWISE	CLOCKWISE	CLOCKWISE	CLOCKWISE	HARDWOOD	SOFTWOOD	HARDWOOD	SOFTWOOD	SOFTWOOD
B 1	100	95	90	75	75	240 <sup>3</sup>	95 <sup>3</sup>	80	90	110
B 2	125	95	90	75	-			60	- <sup>3</sup>	90
B 3	95	105	80	70 <sup>1</sup>	-			75	- <sup>3</sup>	115
B 4	110	95	80	70 <sup>1</sup>	-			75 <sup>2</sup>	- <sup>3</sup>	90
B 5	110	100	80	75 <sup>1</sup>	-			80	-	110
B 6	105	100	90	65 <sup>1</sup>	-			75	-	80

NOTE: As soon as the nut was slightly loosened, head would spring freely and pliers were used to remove the nut. Bolt head would not hold at all, thus preventing testing. Bolts hammered into wood were to better. Head turned before nut could be backed off - this value maximum obtained.

Field Data Sheet  
PALLET BOLT DEVELOPMENT  
Bolt Type

SUPPLY ENG. DIV.  
U.S.N.S.R.&D.F.  
BAYONNE, N. J.

Date: 11/8/48  
Rec'd by: H. Forcasso

BOLT TYPE	TEST NO. 1				TEST NO. 2		TEST NO. 3		TEST NO. 4			
	TONGS BEING TO CLAMP BOLT HEAD TO SLIP OR FAIL (IN - LBL.)				TONGS BEING TO SLACK BOLT OFF BOLT (IN - LBL.)		TONGS BEING TO SLACK BOLT OFF AFTER WEATHERING (IN - LBL.)		TONGS TO BE BOLT HEAD INTO BOLT (IN - LBL.)		TONGS BEING TO FINAL TIGHTENING (IN - LBL.)	
	ARMED	CLOCKWISE	COUNTERCLOCKWISE	SOFTWOOD	PAYWOOD	SOFTWOOD	ARMED	SOFTWOOD	ARMED	SOFTWOOD	ARMED	SOFTWOOD
1	150	120 <sup>2</sup>		55	75	300 <sup>4</sup>	190 <sup>4</sup>	60	75	85	100	
2	145 <sup>1</sup>	115 <sup>1</sup>		70	70			60	75	90	90	
3	140	115 <sup>2</sup>		70	65			90	75	90	90	
4		85 <sup>2</sup>		80	-			60	-	85	-	
5		95 <sup>1</sup>		75	-			50	-	95	-	
6		110 <sup>2</sup>		80	-			55	-	100	-	

NOTE: Legs in this type bolt are not uniformly made. Some are bent down in a clockwise direction. Others in a counter clockwise direction. Also legs are not uniformly positioned with respect to the face.

Field Data Sheet  
PALLET BOLT DEVELOPMENT  
Bolt Type

SUPPLY ENG. DIV.  
U.S.A.S.A.D.D.F.  
MAYONNE, N. I.

Date: 11/8/49  
Rec'd by: H. Toscano





TEST NO.	TEST NO. 1		TEST NO. 2		TEST NO. 3		TEST NO. 4		
	FORCES APPLIED TO CARTRIDGE BOLT HEAD TO SLIP OR FAIL (IN - LBS.)		FORCES REQUIRED TO BACK OUT OFF BOLT (IN - LBS.)		FORCES REQUIRED TO BACK OUT OFF BOLT AFTER WEATHERING (IN - LBS.)		FORCES REQUIRED FOR FINAL TIGHTENING (IN - LBS.)		
	HARDWOOD	SOFTWOOD	HARDWOOD	SOFTWOOD	HARDWOOD	SOFTWOOD	HARDWOOD	SOFTWOOD	SOFTWOOD
1	75	40	65	70	290		60	80	90
2	75	35	65				45	85	
3	75	35					25		
4	75	45	75				45	80	
5	65	35	100				50	85	
6	70	35							

NOTE: 1. The test was conducted on 25th and 26th April 1964.  
 2. The test was conducted on 25th and 26th April 1964.  
 3. The test was conducted on 25th and 26th April 1964.

Field Data Sheet  
 PALLET BOLT DEVELOPMENT  
 Bolt Type

SUPPLY BULK DIV.  
 U.S. ARMY  
 BAYONNE, N. J.

Date: 11/18/68  
 Rec'd by: K

BOLT TYPE	TEST NO. 1			TEST NO. 2			TEST NO. 3			TEST NO. 4		
	TORQUE ENGAGED TO CARES BOLT WALK TO SLIP OR FAIL (IN LBS.)			TORQUE ENGAGED TO BACK OFF BOLT (IN LBS.)			TORQUE ENGAGED TO BACK SET OFF AFTER WEATHERING (IN LBS.)			TORQUE ENGAGED FOR FINAL TIGHTENING (IN LBS.)		
	HARDNESS	SOFTNESS	SCREWS	HARDNESS	SOFTNESS	SCREWS	HARDNESS	SOFTNESS	SCREWS	HARDNESS	SOFTNESS	SCREWS
E 1	-	-	-	120	125	-	340	330	-	160	130	-
E 2	-	-	-	130	130	-			-	170	140	-
E 3	-	-	-	120	125	-			-	165	130	-
E 4	-	-	-	140	140	-			-			-
E 5	-	-	-	115	130	-			-			-
E 6	-	-	-	125	130	-			-			-

NOTE: Bolt shank sheared at approximately 190 inch-lbs. before head turned

Field Data Sheet  
PALLET BOLT DEVELOPMENT  
Bolt Type

SUPPLY ENG. DIV.  
U.S. N.S.R. & D.F.  
BAYONNE, N. J.

Date: 12/8/49  
Rec'd by: H. TOSCARO

BOLT TYPE	TEST NO. 1			TEST NO. 2		TEST NO. 3		TEST NO. 4			
	TORQUE REQUIRED TO CAUSE BOLT HEAD TO SLIP OR FAIL (1X - LBS.)			TORQUE REQUIRED TO FACE NOT OFF BOLT (1X - LBS.)		TORQUE REQUIRED TO REMOVE BOLT FROM BOLT HEAD INTO WOOD (1X - LBS.)		TORQUE REQUIRED FOR 1/2 TURN TIGHTENING (1X - LBS.)			
	BARWOOD	CLOCKWISE	COUNTER-CLOCKWISE	BARWOOD	SOFTWOOD	BARWOOD	SOFTWOOD	BARWOOD	SOFTWOOD	BARWOOD	SOFTWOOD
E1	60	50		75	75	15	-1	95	95		
E1	85	30		70	80	20	-1	90	105		
E1	80	40		75	80	25	-1	100	100		
E1	65	35		75	75	25	-1	100	85		
E1	70	45		-1	-1	-1	-1	-1	-1		
E1	60	35		-1	-1	-1	-1	-1	-1		

NOTE: Bolt would not hold while passing leeches in test in ice-ant which requires 26 lb. - lbs.

Field Notes Show  
PALLET BOLT DEVELOPMENT  
Bolt Type

51

SUPPLY ENG. DIV.  
U.S.M.A.R.A.D.F.  
BAYONNE, N. J.

Date: 11/9/49  
Rec'd BY: N. Torgano

BOLT TYPE	TEST NO. 1				TEST NO. 2		TEST NO. 3		TEST NO. 4			
	TORQUE REQUIRED TO CAUSE BOLT HEAD TO SLIP OR FAIL (11. - 12.1)				TORQUE REQUIRED TO BACK OUT OFF BOLT (11. - 12.1)		TORQUE REQUIRED TO BACK OUT OFF AFTER WEATHERING (11. - 12.1)		TORQUE TO PENETRATE BOLT INTO WOOD (11. - 12.1)		TORQUE REQUIRED FOR FINAL TIGHTENING (11. - 12.1)	
	HARDWOOD		SOFTWOOD		HARDWOOD	SOFTWOOD	HARDWOOD	SOFTWOOD	HARDWOOD	SOFTWOOD	HARDWOOD	SOFTWOOD
E2	50	45	45	45	-1	85	300 <sup>3</sup>	-1	50	-1	100	
E2	55	40	40	40	70	100		30	60	75	105	
E2	45	40	40	40	65	90		35	-1	85	105	
E2	40	45	45	45	-1	90		-1	-1	-1	100	
E2	-1	40	40	40	-1	100		-1	-1	-1	105	
E2	-1	40	40	40	-1	90		-1	-1	-1	100	

NOTE: 1 - Impression of weathering is as it appeared freely at 12 lbs. 2 - Head turned and nut could not be removed

Field Data Sheet  
PALLET BOLT DEVELOPMENT  
Bolt Type

E 2

SUPPLY ENG. DIV.  
U.S.N.S.R. 80.F.  
BAYONNE, N. J.

Date: 11/8/49  
Rec'd by: M. Tolano

NUT TYPE	TEST NO. 1				TEST NO. 2		TEST NO. 3		TEST NO. 4			
	TORQUE MEASURES TO CAUSE BOLT HEAD TO SLIP OR FAIL (II. - LGR.)				TORQUE REQUIRED TO BACK OUT OFF BOLT (II. - LGR.)		TORQUE REQUIRED TO BACK OUT OFF AFTER WEATHERING (II. - LGR.)		TORQUE TO BRUY BOLT HEAD INTO WOOD (II. - LGR.)		TORQUE REQUIRED FOR FINAL TIGHTENING (II. - LGR.)	
	HARDWOOD	COUNTER-CLOCKWISE	CLOCKWISE	SOFTWOOD	HARDWOOD	SOFTWOOD	HARDWOOD	SOFTWOOD	HARDWOOD	SOFTWOOD	HARDWOOD	SOFTWOOD
E3	50	40	45	75	85	75	160	35	100	90	90	
E3	48	45	45	70	75			40	95			
E3	55	40	40	65	80			20	100	90	90	
E3	50	35	35	85	80			40	100	90	90	
E2	60	35	35	70	85			55	110	90	90	
E3	40	40	40	90	75			40	110	90	90	

NOTE: Head tapered and nut could not be removed.

Field Data Sheet  
**PALLET BOLT DEVELOPMENT**  
 Bolt Type

E3

SUPPLY ENG. DIV.  
 U.S.N.S.B.O.F.  
 BAYONNE, N. J.

Date: 1/28/48  
 Rec'd by: L. Torrance

NUT TYPE	TEST NO. 1				TEST NO. 2		TEST NO. 3		TEST NO. 4		
	TORQUE REQUIRED TO CAPRE BOLT HEAD TO SLIP OR FAIL (IN.-LBS.)				TORQUE REQUIRED TO BACK NOT OFF BOLT (IN.-LBS.)		TORQUE REQUIRED TO BACK NOT OFF AFTER WEATHERING (IN.-LBS.)		TORQUE REQUIRED FOR FINAL TIGHTENING (IN.-LBS.)		
	HARDWOOD		SOFTWOOD		HARDWOOD	SOFTWOOD	HARDWOOD	SOFTWOOD	HARDWOOD	SOFTWOOD	HARDWOOD
F	190	-	180	-	85	65	-	-	-	100	90
F	195	-	160	-	95	80	-	-	-	100	95
F	90	-	190	-	90	75	-	-	-	100	90
F	195	-	190	-	85	-	-	-	-	100	-
F	200	-	200	-	90	-	-	-	-	100	-
F	200	-	185	-	90	-	-	-	-	100	-
F	200	-	200	-	-	-	-	-	-	-	-
F	195	-	200	-	-	-	-	-	-	-	-
F	200	-	175	-	-	-	-	-	-	-	-

NOTE: At all breakers use of more fine apt. could still be backed off without turning bolt.

Field Data Sheet  
 PALLET BOLT DEVELOPMENT  
 Bolt Type

SUPPLY ENG. DIV.  
 U.S.N.B.R.A.D.F.  
 BAYONNE, N. J.

Date: 11 8 49  
 Rec'd by: H



BOLT TYPE	TEST NO. 1				TEST NO. 2		TEST NO. 3		TEST NO. 4			
	TORQUE REQUIRED TO CAREN BOLT HEAD TO SLIP OR FAIL (IN.-LBS.)				TORQUE REQUIRED TO BACK WRT OFF BOLT (IN.-LBS.)		TORQUE REQUIRED TO BACK WRT OFF AFTER WEATHERING (IN.-LBS.)		TORQUE TO DRAW BOLT HEAD INTO WOOD (IN.-LBS.)			
	HARDWOOD		SOFTWOOD		HARDWOOD	SOFTWOOD	HARDWOOD	SOFTWOOD	HARDWOOD	SOFTWOOD	RESERVED	
G1	200	160	160	160	80	115			70	75	100	125
G1	180	160	160	160	80	105			80	80	110	130
G1	150	160	160	160	80	95			75	90	110	125
G1	150	140	140	140	85	85			80	75	115	115
G1	145	145	145	145	80	80			70	60	120	105
G1	185	160	160	160	90	80			75	65	120	100
G1	-	140	140	140	-	-			-	-	-	-

NOTE: Bolt sheared at this point - head was very close to a knot.

Field Data Sheet  
PALLET BOLT DEVELOPMENT  
Bolt Type

SUPPLY ENG. DIV.  
U.S.N.S.A. M.F.  
RAYONNE, N. J.

Date: 11/8/49  
Rec'd by: M. Tescaro

## APPENDIX

A

The nut used in Test 2, 3, and 4 is illustrated in Figure 5. It is punched and formed from steel strip and zinc plated. The body of the nut is threaded internally and a locking feature is added by forcing a small area out of round by controlled impact. The upper portion of the body contains a hexagonal socket which will accept a 5/16" Allen wrench. The head has three notches equally spaced around its edge. These notches permit tightening or loosening with a spanner wrench (or in an emergency, a hammer

and punch or screwdriver). Figure 6 shows one of the nuts on a spanner wrench.

The hex socket withstood torques of over 300 inch-pounds without stripping (Test 4) and when the lower part of the body was gripped in a vise, the shearing seen in Figure 7 occurred in excess of 300 inch-pounds.

This nut is manufactured by *United-Carr Fastener Corporation, Cambridge, Massachusetts*, and is sold under the name of "Tee-Nut".