

ESTI FILE COPY

ESD ACCESSION LIST
ESTI Call No. **AL 55191**
Copy No. 1 of 1 cys

ESD RECORD COPY

RETURN TO
SCIENTIFIC & TECHNICAL INFORMATION DIVISION
(ESTI), BUILDING 1213

Technical Note

1967-16

J. U. Beusch

Stable Equilibrium Orientation
of a Spacecraft which Contains
a Momentum Wheel

20 February 1967

Prepared under Electronic Systems Division Contract AF 19(628)-5167 by

Lincoln Laboratory

MASSACHUSETTS INSTITUTE OF TECHNOLOGY

Lexington, Massachusetts



1950649190

The work reported in this document was performed at Lincoln Laboratory, a center for research operated by Massachusetts Institute of Technology, with the support of the U.S. Air Force under Contract AF 19(628)-5167.

This report may be reproduced to satisfy needs of U.S. Government agencies.

Distribution of this document is unlimited.

MASSACHUSETTS INSTITUTE OF TECHNOLOGY
LINCOLN LABORATORY

STABLE EQUILIBRIUM ORIENTATION OF A SPACECRAFT
WHICH CONTAINS A MOMENTUM WHEEL

J. U. BEUSCH

Group 66

TECHNICAL NOTE 1967-16

20 FEBRUARY 1967

LEXINGTON

MASSACHUSETTS

ABSTRACT

The orientation of a spacecraft when it is in a stable equilibrium state is studied. The spacecraft contains a single momentum wheel which stores angular momentum. The axis of the wheel is not necessarily parallel to a principal axis of the spacecraft. For an arbitrary but fixed speed of the wheel relative to the spacecraft body, it is shown that there may be one, two, or three stable equilibrium points. At each of these points, the body may spin about an axis which is fixed in both spacecraft and inertial coordinates. The orientation of this axis in spacecraft coordinates can be determined from expressions in this report. A threshold can be determined such that, if the speed of the wheel relative to the spacecraft is larger than this threshold, there is only one stable equilibrium point. This information can be used to determine the eventual orientation of the spacecraft provided it is designed such that, if it becomes seriously misoriented, the momentum wheel drive motor automatically holds the wheel speed to a predetermined value.

Accepted for the Air Force
Franklin C. Hudson
Chief, Lincoln Laboratory Office

Table of Contents

1. Introduction	1
2. Formulation of the Problem	2
3. Points of Minimum Kinetic Energy	3
4. Example: Wheel Axis Along a Principal Axis	6
5. Example: Wheel Axis Which may not be Along a Principal Axis	7
6. Conclusions	9
Appendix	13
References	25

STABLE EQUILIBRIUM ORIENTATION OF A SPACECRAFT WHICH CONTAINS A MOMENTUM WHEEL

1. Introduction

The orientation of a spacecraft when it is in a stable equilibrium state is studied in this report. The spacecraft is assumed to contain a single momentum wheel with its spin axis in an arbitrary direction and a damper for dissipation of energy. Two situations are already well understood.

(a) The wheel is spinning at such a speed that the magnitude of its angular momentum equals that of the entire spacecraft. In its unique stable equilibrium state, the spacecraft will orient itself such that the momentum vector of the wheel coincides with the momentum vector of the entire spacecraft which is fixed in inertial coordinates.

(b) The wheel has stopped spinning relative to the spacecraft body. There are two stable equilibrium states. In each, the axis of maximum moment of inertia of the spacecraft is oriented in one of two possible directions along the momentum vector and the spacecraft is spinning about this axis.

In each of these two situations, when the spacecraft is not in a stable equilibrium state, the damper dissipates energy and drives the spacecraft toward a stable equilibrium state.* In this stable equilibrium state, the damper dissipates no energy since the spacecraft is either stationary or spinning about a fixed axis.

Intermediate situations between these two extreme situations are analyzed in this report. The momentum wheel speed relative to the body is assumed to be held constant by a drive motor and the orientation of the spacecraft when it is in a stable equilibrium state is investigated. It will be shown that for an arbitrary but fixed wheel speed in any stable equilibrium state the

* In theory, no dissipation takes place when the spacecraft is in an unstable equilibrium state, but this case is ignored in this report because in practice a disturbance torque will perturb the spacecraft from an unstable equilibrium state.

body will rotate about some axis which orients itself along the spacecraft momentum vector. The damper dissipates no energy while the spacecraft spins about this axis. This axis is not necessarily the wheel axis or a principal axis of the spacecraft. If the wheel speed is larger than some threshold, it will be shown that there is only one stable equilibrium state and the orientation of the spacecraft when in this state can be determined. If the spacecraft is designed so that when it becomes misoriented the momentum wheel is automatically driven at a predetermined speed, the methods of this report can be used to determine the equilibrium orientation of the spacecraft.

The precise evaluation of the expressions of this report requires a knowledge of h , the magnitude of the spacecraft angular momentum. For example, the threshold varies linearly with h . However, in many cases, the direction of the axis in spacecraft coordinates about which the body spins is insensitive to fairly large variations in h as long as the wheel speed remains above the threshold. Therefore, the results of this report are useful when h is known only approximately.

When two of the principal moments of inertia are equal, the results of this report require some special interpretation since some of the expressions become infinite. The best way to handle this situation is to let the moments of inertia differ by a small quantity and observe what happens when this quantity approaches zero. In practice, no two moments of inertia are exactly equal, so the results for equal moments of inertia are not emphasized in this report.

For the special case where the spacecraft body is symmetric about the wheel axis, the threshold value of the wheel speed is determined in Ref. 2 using a somewhat different approach.

2. Formulation of the Problem

Consider a spacecraft which is rigid except that it contains a momentum wheel that is free to rotate about a shaft parallel to an axis Z in spacecraft coordinates which passes through the spacecraft center of mass. Define the direction of positive Z such that a vector representing angular velocity of the wheel with respect to the rest of the spacecraft is in the direction of positive Z .

The momentum wheel is assumed to have symmetry and maximum moment of inertia about its spin axis, and all parts of the spacecraft other than the wheel will be referred to as the body. Two additional coordinates X and Y are chosen so that XYZ forms a right-hand orthogonal coordinate system fixed to the spacecraft body and centered at the spacecraft center of mass. If the momentum wheel were clamped in any position, the rigid spacecraft would have three principal axes. Denote these axes x, y, and z, which form a right-hand orthogonal coordinate system such that the positive Z axis is in the octant $x \geq 0$, $y \geq 0$, and $z \geq 0$, and such that $I_x \geq I_y$ and $I_x \geq I_z$ where I_x , I_y , and I_z are the principal moments of inertia of the spacecraft (if the wheel is clamped). See Fig. 1.

Let the moment of inertia of the wheel about its axes be C and the angular velocity of the wheel with respect to the body be a vector $\underline{\omega}$ along Z. The spacecraft has a total angular momentum \underline{h} in some arbitrary direction. The vector \underline{h} can be broken into two components, a vector $C\underline{\omega}$ along Z and a vector $\underline{h} - C\underline{\omega}$. Let the components of $C\underline{\omega}$ along x, y, and z have magnitude $a_x C\omega$, $a_y C\omega$, and $a_z C\omega$ where $\omega = |\underline{\omega}|$ and let the components of \underline{h} have magnitude $b_x h$, $b_y h$, and $b_z h$ where $h = |\underline{h}|$. Then $a_x^2 + a_y^2 + a_z^2 = 1$, $b_x^2 + b_y^2 + b_z^2 = 1$, and, because of the way x, y, and z were defined, $a_x \geq 0$, $a_y \geq 0$, and $a_z \geq 0$.

3. Points of Minimum Kinetic Energy

In this section, we consider a problem where a_x , a_y , a_z , I_x , I_y , I_z , C, h, and ω are fixed and examine the minima of the function

$$2T(b_x, b_y, b_z)/h^2 = (b_x - \rho a_x)^2/I_x + (b_y - \rho a_y)^2/I_y + (b_z - \rho a_z)^2/I_z + \rho^2/C \quad (1)$$

where T is the kinetic energy of the spacecraft and $\rho = (\frac{\omega C}{h})$. Equation 1 is a standard representation of the kinetic energy in terms of components of angular momentum and principal moments of inertia. See Ref. 1 or 3.

For each point on the unit sphere, $b_x^2 + b_y^2 + b_z^2 = 1$, the value of T can be computed using Eq. 1. The assumption that ω is fixed implies that a

motor drives the wheel at a constant speed relative to the rest of the spacecraft. Assuming that energy is dissipated in the body by the damper, regardless of the initial values of b_x , b_y , and b_z (initial orientation of \underline{h} in the spacecraft coordinate system), the spacecraft will eventually orient itself so that b_x , b_y , and b_z take on the values of the coordinates of a minimum of T . In this stable equilibrium state, the direction of \underline{h} is fixed in both inertial coordinates and in the spacecraft coordinates. Therefore, the spacecraft body is either stationary with respect to an inertial frame of reference or rotating about \underline{h} . In this report the terms minimum and stable equilibrium point are used interchangeably. At a minimum, the damper dissipates no energy since the body is either stationary or spinning about a fixed axis.

There are several situations in which knowledge of the components of \underline{h} , or equivalently the direction of the axis about which the body spins, in spacecraft coordinates is valuable. Two situations are:

(a) The spacecraft loses power for a while (e. g., while in the earth's shadow) so that the momentum wheel stops spinning relative to the body. Power is regained and the momentum wheel is automatically accelerated to a predetermined speed ω relative to the body. In many practical cases, the magnitude of the angular momentum, h , will be much larger than the magnitude of angular momentum changes caused by disturbance torques during the power outage so that the direction and magnitude of \underline{h} remain approximately fixed in inertial space. Knowledge of the components of \underline{h} in the spacecraft coordinate system would be extremely helpful in bringing about complete recovery of the spacecraft from misorientation suffered while the momentum wheel was without power.

(b) Due to faulty ejection of the spacecraft from the launch vehicle or large disturbance torques caused by failure of gas jets in the open position, the magnitude and orientation of \underline{h} in inertial coordinates is unknown but the wheel is automatically held by the motor to a predetermined speed ω relative to the body. Knowledge of the orientation of \underline{h} in spacecraft coordinates would be helpful as a first step in determining the orientation of \underline{h} in inertial space and eventual spacecraft recovery.

It is shown in the appendix that the function $T(b_x, b_y, b_z)$ always has one and only one minimum in the region $b_x \geq 0, b_y \geq 0, b_z \geq 0$. T may have zero, one, or two minima in the region $b_x < 0, b_y \geq 0, b_z \geq 0$ and there are no minima in any other regions. Two sufficient conditions that T have a unique minimum are

$$\rho^2 = \left(\frac{\omega C}{h}\right)^2 > \frac{(I_x - I_y)^2}{\left[(a_{xy} I_y)^{2/3} + (a_{yx} I_x)^{2/3} \right]^3} \quad (2)$$

and

$$\rho^2 = \left(\frac{\omega C}{h}\right)^2 > \frac{(I_x - I_z)^2}{\left[(a_{xz} I_z)^{2/3} + (a_{zx} I_x)^{2/3} \right]^3} \quad (3)$$

If either Eq. 2 or 3 is satisfied, T will have one and only one minimum. Let $t = C/h$ times the positive square root of the smaller of the two expressions on the right-hand side of Eqs. 2 and 3. The coordinates of this minimum satisfy the relation given in Table 1 for various ranges of the parameters $a_x, a_y,$ and a_z .

Table 1

<u>Conditions on a_x, a_y, a_z</u>	<u>Coordinates of Unique Minimum Satisfy</u>
$a_x = 1, a_y = a_z = 0^*$	$b_x = 1, b_y = b_z = 0$
$a_y = 1, a_x = a_z = 0^*$	$b_y = 1, b_x = b_z = 0$
$a_z = 1, a_x = a_y = 0^*$	$b_z = 1, b_x = b_y = 0$
$a_x = 0, a_y > 0, a_z > 0^*$	$b_x = 0, b_y = \rho a_y I_z b_z / [\rho a_z I_y + (I_z - I_y) b_z],$ $b_y = +\sqrt{1 - b_z^2}$
$a_y = 0, a_x > 0, a_z > 0$	$b_y = 0, b_z = \rho a_z I_x b_x / [\rho a_x I_z + (I_x - I_z) b_x],$ $b_x = +\sqrt{1 - b_z^2}$

* For these four cases, a necessary condition for T to have a unique minimum is that either Eq. 2 or 3 with $>$ replaced by \geq be satisfied.

Table 1 (Cont.)

$$a_z = 0, a_x > 0, a_y > 0$$

$$b_z = 0, b_y = \rho a_y I_x b_x / [\rho a_x I_y + (I_x - I_y) b_x],$$

$$b_x = + \sqrt{1 - b_y^2}$$

$$a_x > 0, a_y > 0, a_z > 0$$

$$b_z = \rho a_z I_x b_x / [\rho a_x I_z + (I_x - I_z) b_x]$$

$$b_y = \rho a_y I_x b_x / [\rho a_x I_y + (I_x - I_y) b_x]$$

$$b_x = + \sqrt{1 - b_y^2 - b_z^2}$$

Given the values of the spacecraft parameters, a threshold t of wheel speed can be determined from Eqs. 2 and 3 such that if $\omega > t$ the vector \underline{h} has only one stable equilibrium point in the spacecraft coordinate system. In this equilibrium position, the components of \underline{h} can be determined from the relations of Table 1. If $\omega \leq t$, there may be as many as three equilibrium positions. In each equilibrium position, the spacecraft body may rotate about \underline{h} . These positions may be studied using the expressions of the appendix. It is desirable that the spacecraft be designed to keep $\omega > t$ so that the additional equilibrium positions will not exist.

4. Example: Wheel Axis Along a Principal Axis

Consider a spacecraft composed of two rigid bodies. See Fig. 2. The first body contains a momentum wheel with its spin axis parallel to Z. The second body rotates very slowly (e. g., once per day for spacecraft in synchronous equatorial orbit) about Z with respect to the first and Z is a principal axis of both bodies. This slow rotation is caused by a drive which for long periods of time (e. g., twenty-four hours) does not require any sensor input from outside the spacecraft so that during any particular short time interval of interest the spacecraft can be considered to be a rigid body with one principal axis along axis Z. Assume that the moments of inertia normalized by dividing by the constant I_Z are

$$I_X/I_Z = 5.330 + 0.038 \cos 2\theta,$$

$$I_Y/I_Z = 5.160 - 0.038 \cos 2\theta,$$

and

$$I_{XY}/I_Z = 0.38 \sin 2\theta$$

where θ is the angle of body 1 relative to body 2.

Consider the satellite position $\theta = 0$. In this case, the X, Y, and Z axes are the principal axes,

$$I_x/I_z = 5.368,$$

and

$$I_y/I_z = 5.122.$$

The case described here is $a_z = 1$, $a_x = a_y = 0$. Equations 2 and 3 imply that, if $\rho = (\frac{\omega C}{h}) > 1 - (I_z/I_x) = 0.814$, a unique minimum occurs at $b_z = 1$, $b_y = b_x = 0$. Therefore, if the speed of the wheel is always kept high enough so that 81.4% of the angular momentum of the spacecraft is due to the wheel spinning relative to the body, only one stable equilibrium position exists. In this position, the body may be spinning around the Z axis.

If $\rho < 0.814$, the results of the appendix show that there may be two equilibrium positions at

$$b_y = 0,$$

$$b_z = \rho I_x / (I_x - I_z) = \rho / 0.814,$$

and

$$b_x = \pm \sqrt{1 - (\rho / 0.814)^2}.$$

Consider the satellite position $\theta = \pi/2$. Equations 2 and 3 imply that, if $\rho = (\frac{\omega C}{h}) > 0.811$, a unique minimum occurs at $b_z = 1$, $b_y = b_x = 0$. At this stable equilibrium position the body may spin about the Z axis.

5. Example: Wheel Axis Which may not be Along a Principal Axis

Consider a spacecraft composed of two rigid bodies. See Fig. 3. The first body contains a momentum wheel with its spin axis parallel to Z. The second body rotates with respect to the first very slowly about Y and Y is a principal axis of both bodies. With respect to this rotation, the situation is the same as that of the previous example so that for stability analysis the spacecraft can be considered to be a single rigid body which contains a

momentum wheel. Assume that the moments of inertia, normalized by dividing by the constant I_Y , are

$$I_X/I_Y = 7.4 + 0.089 \cos 2\theta,$$

$$I_Z/I_Y = 6.89 - 0.089 \cos 2\theta,$$

and

$$I_{XZ}/I_Y = 0.089 \sin 2\theta$$

where θ is the angle between the two bodies which is considered to be a constant at any particular time. The coordinates x , y , and z are chosen so that z is along Y and x is in the XZ plane displaced an angle φ from X . The condition $I_{xy} = 0$ determines φ . By substituting coordinate transformations into the definition for the moments of inertia, we obtain the relations

$$I_y^2 - I_y(I_Z + I_X) + (I_X I_Z - I_{XZ}^2) = 0,$$

$$I_x = (I_X I_Z - I_{XZ}^2)/I_y,$$

and

$$\sin \varphi = \sqrt{\frac{I_X - I_y}{I_x - I_y}}$$

which can be solved for I_y/I_z , I_x/I_z , and φ .

Consider the case $\theta = \pi/4$. Then

$$I_y/I_z = 6.875$$

$$I_x/I_z = 7.415$$

and

$$\varphi = 9.6^\circ.$$

Therefore, $a_z = 0$, $a_x = 0.167$, $a_y = 0.985$. Equations 2 and 3 imply that, if $\rho = (\frac{\omega C}{h}) > 0.05$, there is only one point of minimum energy. At this point, $b_x = 0$ and b_y and b_x satisfy

$$b_y = 6.35 \rho b_x / (\rho + 0.47 b_x) \quad (4)$$

and

$$b_x = +\sqrt{1 - b_y^2}. \quad (5)$$

This follows from Table 1. Therefore, if the wheel speed is kept high enough so that more than 5% of the angular momentum of the spacecraft is due to the wheel spinning relative to the body, the momentum vector has only one stable equilibrium point in spacecraft coordinates. In this equilibrium position, the vector \underline{h} is not parallel to the wheel axis. The body may spin about an axis along \underline{h} .

If $\rho < 0.051$, there may be one, two, or three equilibrium points depending upon whether Eqs. 4 and 5 have one, two, or three solutions in the region $b_z = 0$, $1 \geq b_y \geq 0$, $1 \geq b_x \geq -1$. This follows from the appendix.

Consider the case $\theta = 0$. Then

$$I_x/I_z = 7.489,$$

$$I_y/I_z = 6.801,$$

and $\varphi = 0^\circ$ so that $a_y = 1$ and $a_x = a_z = 0$. If $\rho > 0.092$, there is only one point of minimum energy located at $b_y = 1$, $b_x = b_z = 0$. In this stable equilibrium state, the body may spin about the Z axis.

If $\rho < 0.092$, there are two stable equilibrium points at $b_z = 0$, $b_y = \rho/0.092$, and $b_x = \pm \sqrt{1 - (\rho/0.092)^2}$.

Consider the case $\theta = \pi/2$. Then

$$I_x/I_z = 7.311,$$

$$I_y/I_z = 6.979,$$

and $\varphi = 0^\circ$ so that $a_y = 1$ and $a_x = a_z = 0$. If $\rho > 0.0454$, there is only one point of minimum energy located at $b_y = 1$, $b_x = b_z = 0$. In this stable equilibrium state, the body may spin about the Z axis. If $\rho < 0.0454$, there are two stable equilibrium points at $b_z = 0$, $b_y = \rho/0.0454$ and $b_x = \pm \sqrt{1 - (\rho/0.0454)^2}$.

6. Conclusions

For $t < \omega \leq h/C$ where t is some threshold, ω is the momentum wheel speed, C is the wheel inertia, and h is the magnitude of the spacecraft angular momentum, there is only one equilibrium state of the spacecraft. If the momentum wheel axis is not parallel to a principal axis of the spacecraft, in

the equilibrium state the spacecraft body spins about an axis which is not parallel to either the wheel axis or a principal axis when $t < \omega < h/C$. If the wheel axis is parallel to a principal axis, in the equilibrium state the body spins about an axis which is parallel to the wheel axis when $t < \omega < h/C$. The value of t and the orientation of the spin axis of the spacecraft body in the equilibrium state can be determined using the expressions derived in this report.

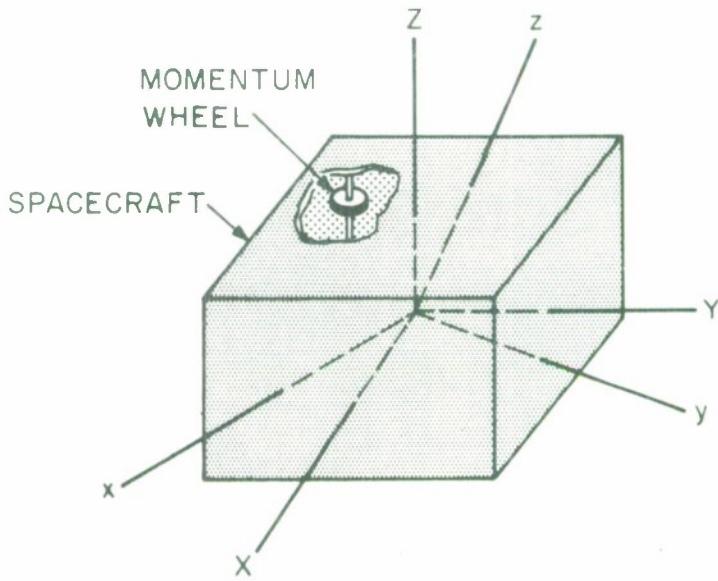

Fig. 1

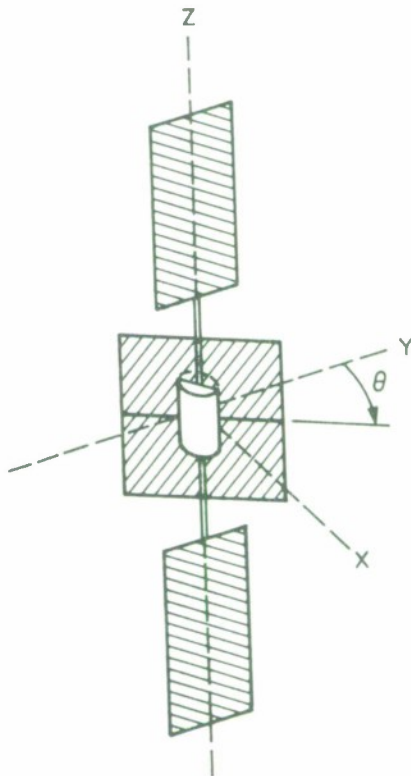

Fig. 2

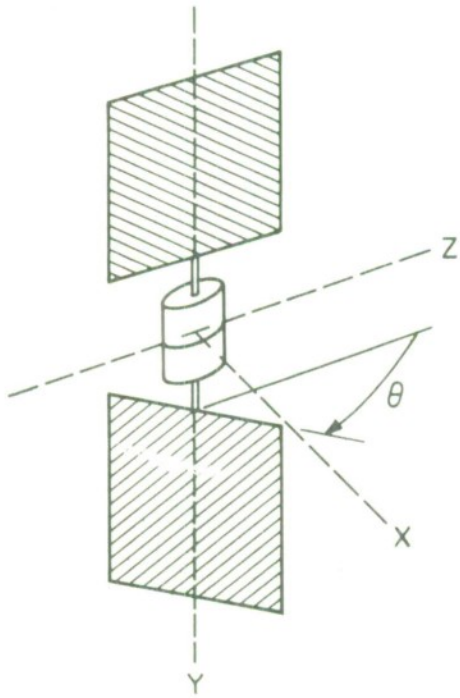

Fig. 3

APPENDIX

1. All minima of $T(b_x, b_y, b_z)$ satisfy the following expressions. If $\rho a_x = 0$,

$$b_x = 0 \quad 0 \leq b_y \leq \frac{\rho a_y I_x}{I_x - I_y} \quad (\text{A-1})$$

$$b_y = \frac{\rho a_y I_x}{(I_x - I_y)} \quad -1 \leq b_x \leq 1. \quad (\text{A-2})$$

If $\rho a_y = 0$,

$$b_y = 0 \quad 0 \leq b_x \leq 1 \quad (\text{A-3})$$

$$b_y = 0 \quad -1 \leq b_x \leq \frac{-\rho a_x I_y}{I_x - I_y}. \quad (\text{A-4})$$

If $\rho a_x > 0$ and $\rho a_y > 0$,

$$b_y = \frac{\rho a_y I_x b_x}{\rho a_x I_y + (I_x - I_y) b_x} \quad 0 \leq b_x \leq 1 \quad (\text{A-5})$$

$$b_y = \frac{\rho a_y I_x b_x}{\rho a_x I_y + (I_x - I_y) b_x} \quad -1 \leq b_x \leq -b_y \left(\frac{a_x I_y}{a_y I_x} \right)^{1/3}$$

$$\text{and } b_x \leq \frac{-\rho a_x I_y}{I_x - I_y}. \quad (\text{A-6})$$

These expressions denote surfaces in b_x, b_y, b_z space. On the b_x, b_y plane they denote curves which are shown in Figs. A-1, A-2, A-3, and A-4. To derive these expressions, let

$$T(b_x, b_y) = T_1/h^2 + T_2/h^2$$

where

$$T_1 = (b_x - \rho a_x)^2 / I_x + (b_y - \rho a_y)^2 / I_y$$

and

$$T_2 = (\pm \sqrt{1 - b_x^2 - b_y^2} - \rho a_z)^2 / I_z + \rho^2 / C.$$

Define r and θ such that $b_x = r \cos \theta$ and $b_y = r \sin \theta$, and consider circles of constant r on the b_x, b_y plane. A necessary condition for a point at radius r to be a minimum of $T(b_x, b_y)$ is that on a circle of constant r this point be a minimum of $T(\theta)$, a function of a single variable θ . Since T_2 is independent of θ , a point is a minimum of $T(\theta)$ if and only if it is a minimum of $T_1(\theta)$. The conditions

$$\frac{1}{2} \frac{dT_1}{d\theta} = \frac{b_x(b_y - \rho a_y)}{I_y} - \frac{b_y(b_x - \rho a_x)}{I_x} = 0$$

and

$$\frac{1}{2} \frac{d^2T_1}{d\theta^2} = \frac{-b_y(b_y - \rho a_y) + (b_x)^2}{I_y} - \frac{b_x(b_x - \rho a_x) - (b_y)^2}{I_x} \geq 0$$

which must be satisfied by all minima for $r > 0$ yield the desired expressions. The point $r = 0$ must be checked separately.

2. All minima of $T(b_x, b_y, b_z)$ satisfy the following expressions. If $\rho a_x = 0$,

$$b_x = 0 \qquad 0 \leq b_z \leq \frac{\rho a_z I_x}{I_x - I_z} \qquad (A-7)$$

$$b_z = \frac{\rho a_z I_x}{(I_x - I_z)} \qquad -1 \leq b_x \leq 1 \qquad (A-8)$$

If $\rho a_z = 0$,

$$b_z = 0 \qquad 0 < b_x \leq 1 \qquad (A-9)$$

$$b_z = 0 \qquad -1 \leq b_x \leq \frac{-\rho a_x I_z}{I_x - I_z} \qquad (A-10)$$

If $\rho a_x > 0$ and $\rho a_z > 0$,

$$b_z = \frac{\rho a_z I_x b_x}{\rho a_x I_z + (I_x - I_z) b_x} \quad 0 \leq b_x \leq 1 \quad (\text{A-11})$$

$$b_z = \frac{\rho a_z I_x b_x}{\rho a_x I_z + (I_x - I_z) b_x} \quad -1 \leq b_x \leq -b_z \left(\frac{a_x I_z}{a_z I_x} \right)^{1/3}$$

$$\text{and } b_x \leq \frac{-\rho a_x I_z}{I_x - I_z} \quad (\text{A-12})$$

These expressions are identical to those of Section 1 except that y is replaced by z . They are derived in the same way as the expression of Section 1.

3. Combining the results of Sections 1 and 2 yields curves in three-dimensional space on which all minima of T must lie. These curves are intersections of the surfaces of Sections 1 and 2 and are shown in Figs. A-5 through A-10 for six cases that occur. A seventh case, $a_x = 0$, $a_y > 0$, and $a_z > 0$ which is shown in Fig. A-11 requires further study. The results of Sections 1 and 2 imply that any minimum of T must be either on the straight line

$$0 \leq b_x^2 \leq 1, \quad b_y = \frac{\rho a_y I_x}{I_x - I_y}, \quad b_z = \frac{\rho a_z I_x}{I_x - I_z}.$$

or the rectangle

$$b_x = 0, \quad 0 \leq b_y \leq \frac{\rho a_y I_x}{I_x - I_y}, \quad 0 \leq b_z \leq \frac{\rho a_z I_x}{I_x - I_z}.$$

Differentiating the expression for T on this rectangle yields further results that all minimum points on the rectangle satisfy

$$b_y = \frac{\rho a_y I_z b_z}{\rho a_z I_y + (I_z - I_y) b_z} \quad 0 \leq b_z \leq \frac{\rho a_z I_x}{I_x - I_y} \quad (\text{A-13})$$

This curve is also shown in Fig. A-11.

The constraint $b_x^2 + b_y^2 + b_z^2 = 1$ implies that only values of T defined for points on the sphere of unit radius centered at the origin are of interest. In particular, all minimum points of T are on this unit sphere so that for each

case of Figs. A-4 to A-11 a minimum of T can only occur where a curve intersects the unit sphere. Therefore, there can be at most two or three minima of T depending on the case. There is always one minimum in the region $b_x \geq 0, b_y \geq 0, b_z \geq 0$ and there can be zero, one, or two minima in the region $b_x < 0, b_y \geq 0, b_z \geq 0$. Equations A-1 through A-13 may be used to determine the coordinates of all minima of T . The next section investigates sufficient conditions for there to be only one minimum or equivalently there to be no minima in the region $b_x < 0, b_y \geq 0, b_z \geq 0$.

4. From Eqs. A-1 through A-6 or Figs. A-1 through A-4, it is evident that sufficient conditions that no minima occur in the region $b_x < 0, b_y \geq 0, b_z \geq 0$ are as follows.

If $\rho a_y = 0,$

$$\frac{-\rho a_x I_y}{I_x - I_y} > -1.$$

If $\rho a_x = 0,$

$$\frac{\rho a_y I_x}{I_x - I_y} < 1.$$

If $\rho a_x > 0, \rho a_y > 0,$

$$(d_{\min})^2 > 1$$

where d_{\min} is the minimum value of

$$d = \left[b_x^2 + \left(\frac{\rho a_y I_x b_x}{\rho a_x I_y + (I_x - I_y) b_x} \right)^2 \right]^{1/2},$$

the distance from the origin to a point on the surface on which all minima must occur in the region $b_x < 0, b_y \geq 0, b_z \geq 0$. Differentiation of d^2 with respect to b_x yields

$$(d_{\min})^2 = \rho^2 \frac{\left[(a_x I_y)^{2/3} + (a_y I_x)^{2/3} \right]^3}{(I_x - I_y)^2}.$$

In all three cases, the sufficient condition for no minima in the region $b_x < 0$, $b_y \geq 0$, $b_z \geq 0$, which implies that there is only one minimum of T , is

$$\rho^2 > \frac{(I_x - I_y)^2}{\left[(a_{xy})^{2/3} + (a_{yx})^{2/3} \right]^3}.$$

An analogous sufficient condition for there to be only one minimum of T can be derived from Eqs. A-7 through A-12. It is

$$\rho^2 > \frac{(I_x - I_z)^2}{\left[(a_{xz})^{2/3} + (a_{zx})^{2/3} \right]^3}.$$

3-66-7183

$$\rho a_x = 0$$

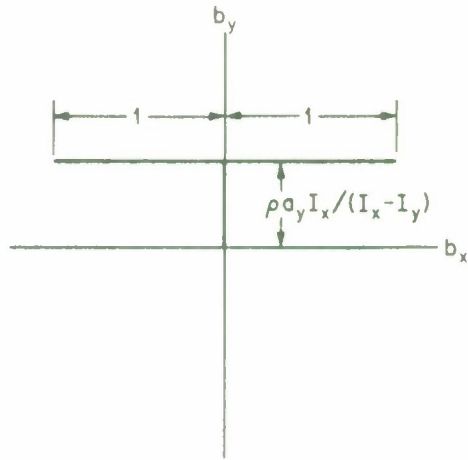

Fig. A-1

3-66-7184

$$\rho a_y = 0$$

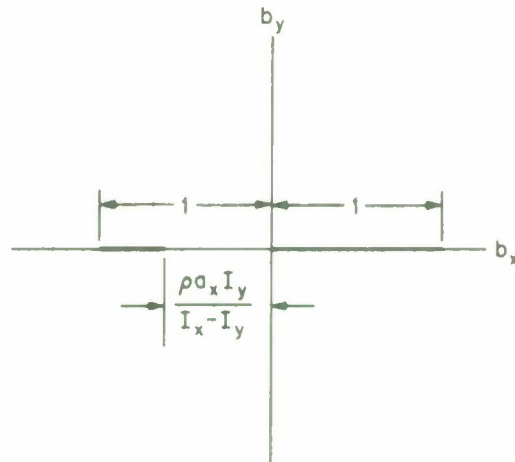

Fig. A-2

$$\rho a_x > 0, \rho a_y > 0, \rho > \frac{I_x - I_y}{(a_x I_y)^{2/3} (a_y I_x)^{1/3}}$$

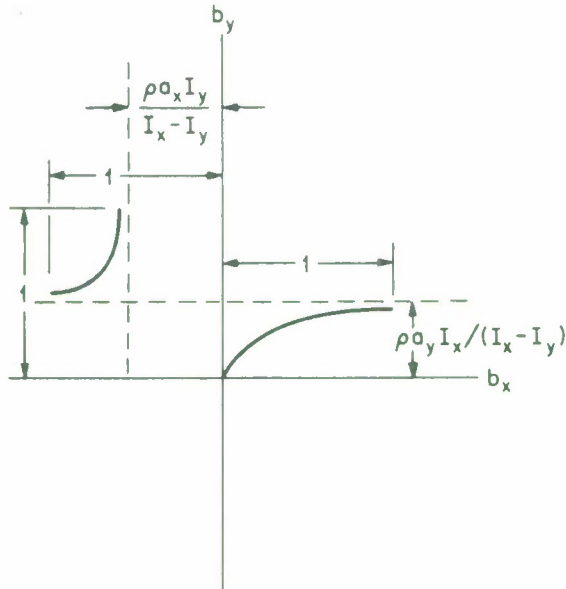

Fig. A-3

$$\rho a_x > 0, \rho a_y > 0, \rho \leq \frac{I_x - I_y}{(a_x I_y)^{2/3} (a_y I_x)^{1/3}}$$

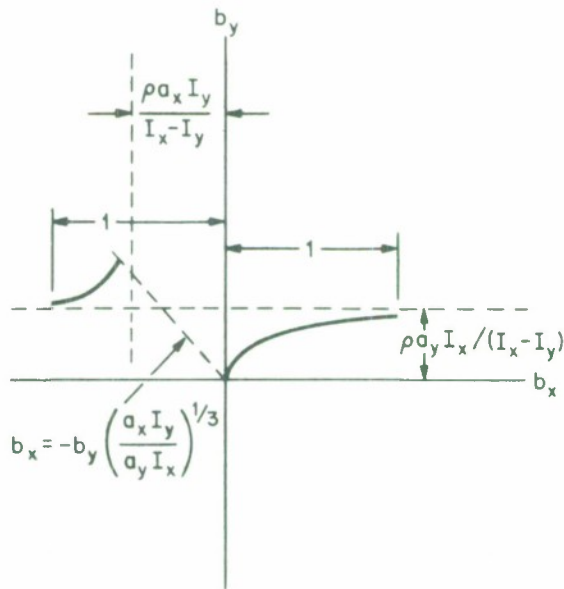

Fig. A-4

$$a_x = 1, a_y = a_z = 0$$

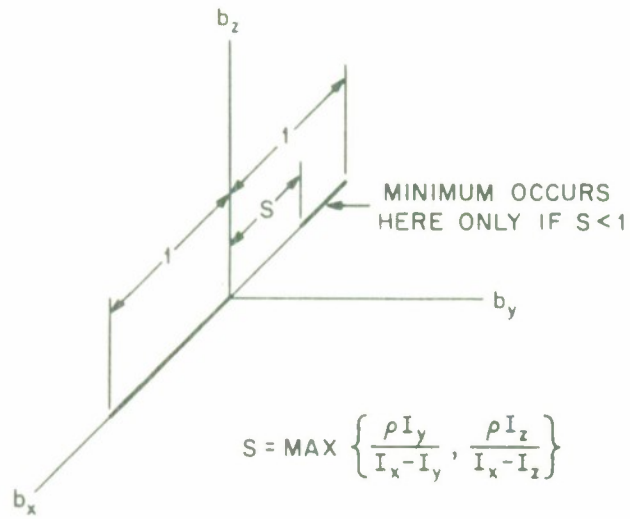

Fig. A-5

$$a_y = 1, a_x = a_z = 0$$

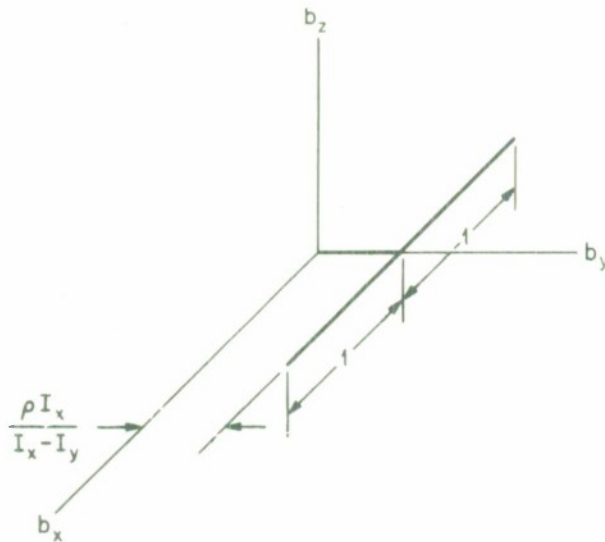

Fig. A-6

$$a_z = 1, a_x = a_y = 0$$

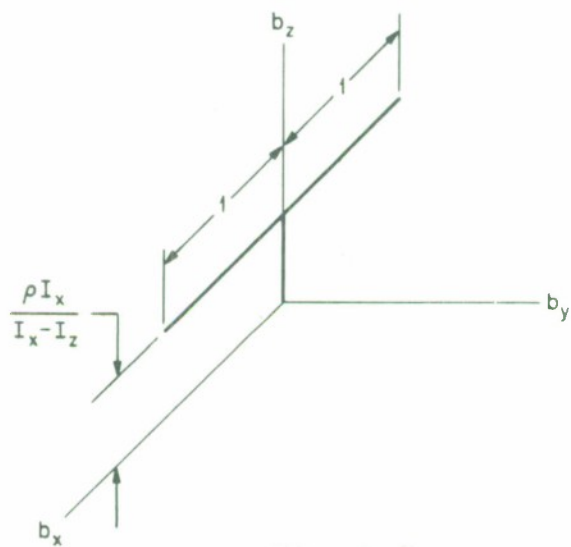

Fig. A-7

$$a_y = 0, a_x > 0, a_z > 0$$

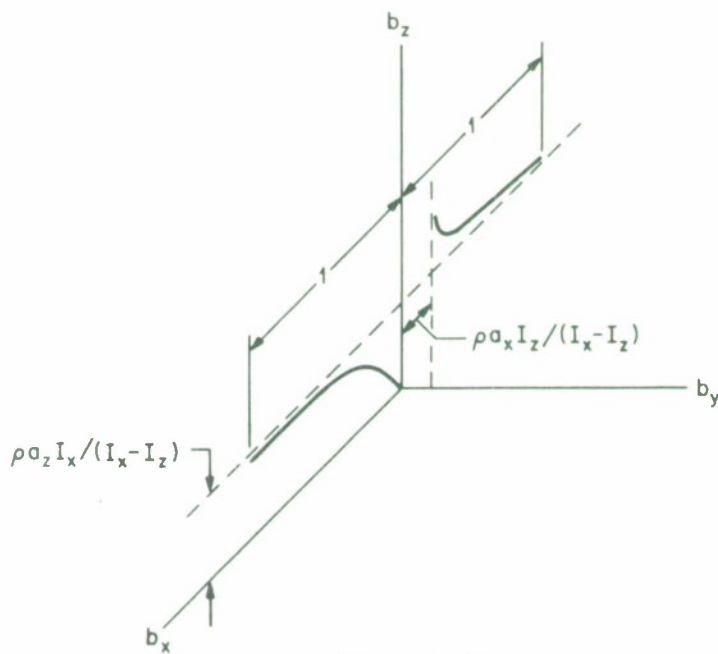

Fig. A-8

3-66-7191

$$a_z = 0, a_x > 0, a_y > 0$$

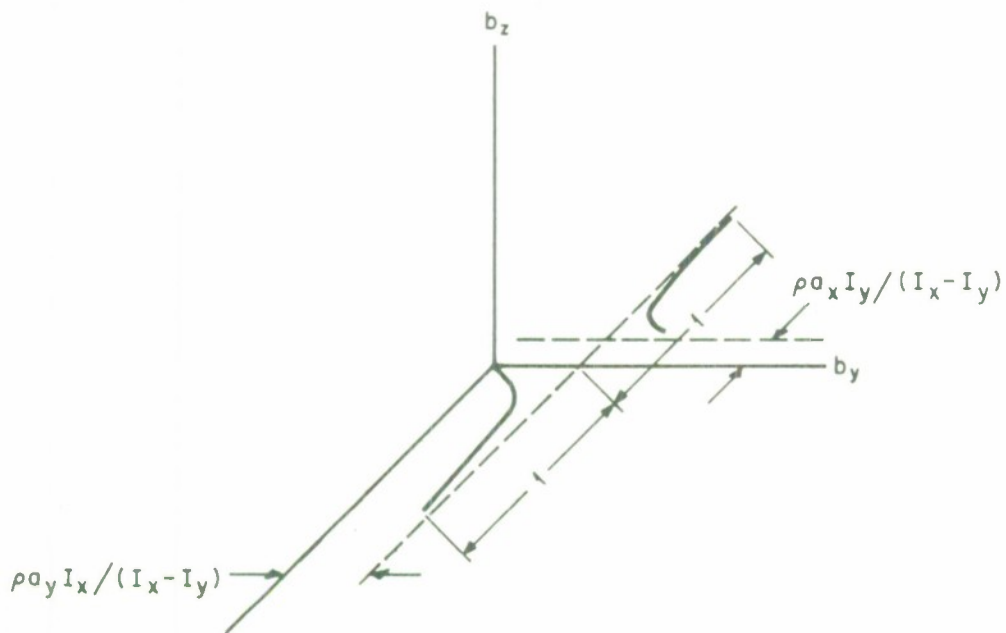

Fig. A-9

$$a_x > 0, a_y > 0, a_z > 0$$

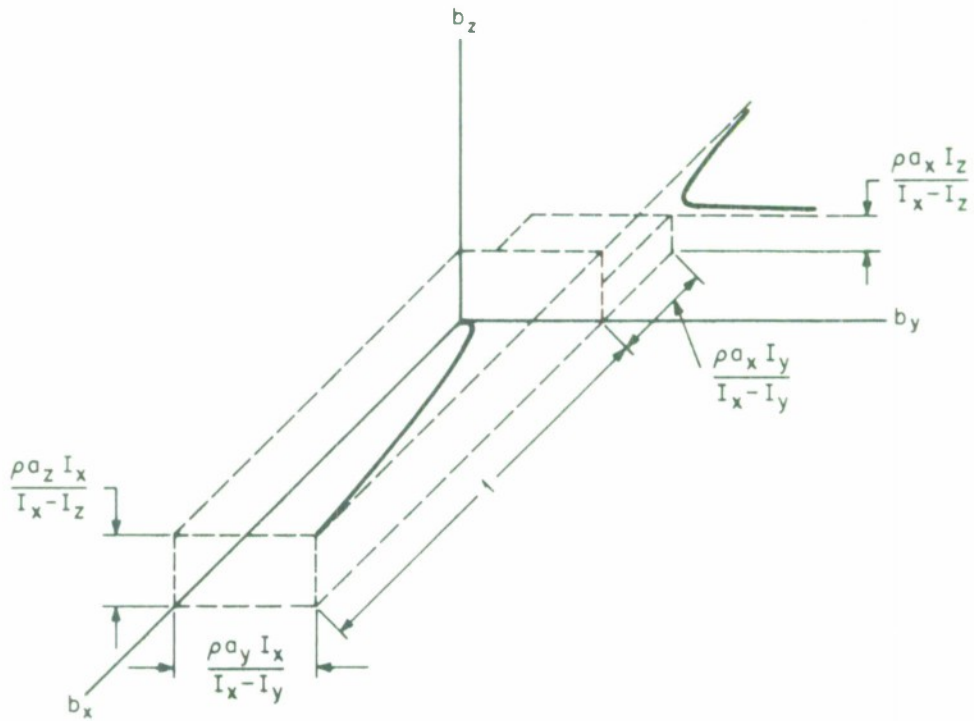

Fig. A-10

$$a_x = 0, a_y > 0, a_z > 0$$

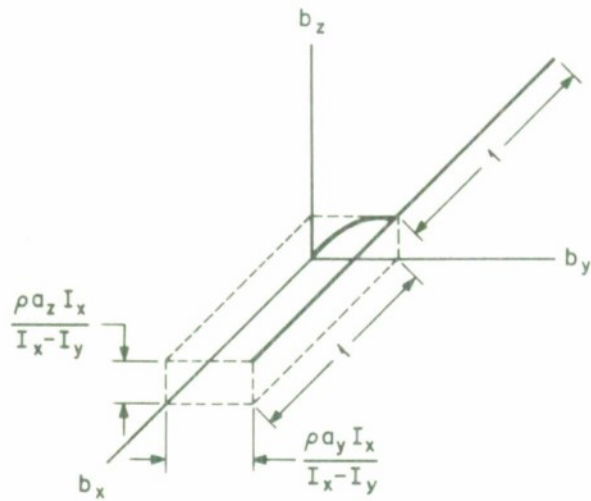

Fig. A-11

REFERENCES

1. H. Goldstein, Classical Mechanics (Addison-Wesley Press, 1950).
2. V. D. Landon, B. Stewart, "Nutational Stability of an Axisymmetric Body Containing a Rotor," Journal of Spacecraft and Rockets (November-December 1964).
3. W. T. Thomson, Introduction to Space Dynamics (John Wiley and Sons, 1961).

Distribution List

Division 6

W. E. Morrow, Jr.
P. Rosen

Group 61

L. J. Ricardi

Group 62

I. L. Lebow

Group 63

A. Braga-Illa
R. Brockett
M. C. Crocker
B. Howland
D. C. MacLellan
L. D. Michelove
B. J. Moriarty
F. W. Sarles, Jr.
N. R. Trudeau
E. A. Vrablik
P. Waldron

Group 64

H. W. Briscoe
J. Capon
J. W. Fairborn
P. L. Fleck, Jr.
C. W. Fraiser
E. Gehrels
P. E. Green, Jr.
R. J. Greenfield
E. J. Kelly, Jr.
R. J. Kolker
R. T. Lacoss
C. A. Wagner

Group 65

J. R. Brown
J. P. Densler
R. G. Enticknap
R. A. Guillette
J. H. Helfrich
R. M. Lerner
O. G. Nackoney
R. V. Wood, Jr.

Group 66

J. U. Beusch
T. J. Goblick, Jr.
B. Reiffen
B. E. White
H. L. Yudkin

Division 7

J. F. Hutzenlaub

Group 71

A. W. Adkins
E. W. Blaisdell
L. P. Farnsworth
H. MacDonald

Group 76

G. A. Gallagher
N. P. Smith
S. H. Wright

DOCUMENT CONTROL DATA - R&D

(Security classification of title, body of abstract and indexing annotation must be entered when the overall report is classified)

1. ORIGINATING ACTIVITY (Corporate author) Lincoln Laboratory, M.I.T.		2a. REPORT SECURITY CLASSIFICATION Unclassified	
		2b. GROUP None	
3. REPORT TITLE Stable Equilibrium Orientation of a Spacecraft which Contains a Momentum Wheel			
4. DESCRIPTIVE NOTES (Type of report and inclusive dates) Technical Note			
5. AUTHOR(S) (Last name, first name, initial) Beusch, John U.			
6. REPORT DATE 20 February 1967		7a. TOTAL NO. OF PAGES 34	7b. NO. OF REFS 3
8a. CONTRACT OR GRANT NO. AF 19 (628)-5167		9a. ORIGINATOR'S REPORT NUMBER(S) Technical Note 1967-16	
b. PROJECT NO. 649L		9b. OTHER REPORT NO(S) (Any other numbers that may be assigned this report) ESD-TR-67-164	
c.			
d.			
10. AVAILABILITY/LIMITATION NOTICES Distribution of this document is unlimited.			
11. SUPPLEMENTARY NOTES None		12. SPONSORING MILITARY ACTIVITY Air Force Systems Command, USAF	
13. ABSTRACT <p>The orientation of a spacecraft when it is in a stable equilibrium state is studied. The spacecraft contains a single momentum wheel which stores angular momentum. The axis of the wheel is not necessarily parallel to a principal axis of the spacecraft. For an arbitrary but fixed speed of the wheel relative to the spacecraft body, it is shown that there may be one, two, or three stable equilibrium points. At each of these points, the body may spin about an axis which is fixed in both spacecraft and inertial coordinates. The orientation of this axis in spacecraft coordinates can be determined from expressions in this report. A threshold can be determined such that, if the speed of the wheel relative to the spacecraft is larger than this threshold, there is only one stable equilibrium point. This information can be used to determine the eventual orientation of the spacecraft provided it is designed such that, if it becomes seriously misoriented, the momentum wheel drive motor automatically holds the wheel speed to a predetermined value.</p>			
14. KEY WORDS spacecraft orientation momentum wheel spacecraft equilibrium state			