

AD651478

**TWO SEISMOGRAPH STATIONS ON THE AFRICAN CONTINENT**

**Paul W. Pomerby**

**Lamont Geological Observatory  
Columbia University  
Palisades, New York**

**Grant No. AF-AFOSR-678-64**

**Project Task No. 8652**

**Final Report**

**Period Covered: 1 April 196 - 31 March 1966**

**1 April 1967**

**Prepared for**

**AIR FORCE OFFICE OF SCIENTIFIC RESEARCH  
OFFICE OF AEROSPACE RESEARCH  
UNITED STATES AIR FORCE  
WASHINGTON, D. C.**

DDC  
MAY 16 1967  
REGISTRY  
A

**WORK SPONSORED BY ADVANCED RESEARCH PROJECTS AGENCY**

**PROJECT VELA-UNIFORM**

**ARPA ORDER NO. 292-6+ Amendments 12 and 17**

**ARPA Project Code No. 4810**

**STATEMENT NO. 1**

**Distribution of This Document is Unlimited**

**ARCHIVE COPY**

TABLE OF CONTENTS

	<u>Page</u>
Introduction	2
Main Station	
Location	3
General Description	3
a. Customs and Immigration Information	3
b. Air transport	4
c. Ground transport	4
d. General Information	4
Installations and Instrumentation	5
a. Buildings	5
b. Short-period seismograph system	6
c. Long-period system	8
d. Magnetic tape recording	10
e. Calibration	11
f. Time reception and generation	12
g. Telemetry reception facilities	12
h. Power facility	13
Satellite Stations	
Location	13
General Description	13
Instrumentation	14
FM Modulation and Telemetry	14
Power supply	16
Detection Capability	16
Noise spectrum at Abéche	18
Future Plans	18
Figure Captions	20

### Introduction

The Abéché, Chad, seismograph station was initially established in February 1965. The south and west satellite stations were placed in operation in March 1966. The new west satellite was established in late May 1966. The station was established as a cooperative research project between the Lamont Geological Observatory of Columbia University (LGO) and the Amis de Laboratoire de Physique de l'Ecole Normale Supérieure (ALPENS) under the sponsorship of the Air Force Office of Scientific Research (AFOSR). The ALPENS group is directed by Professor Yves Rocard in Paris; however, the immediate operations in Chad are under the supervision of Mr. Jacques Bersia whose address is BP 91, Abéché, Chad. A native high school graduate assists Mr. Bersia with routine work like developing photographic records, making time marks, etc. Other local personnel include a driver-mechanic, a carpenter, gardener and guard. A Land Rover is used for transportation to the satellite stations.

Abéché was selected as the site for this station principally for its geographical location which places it in the center of Africa about equidistant from the oceans in all directions. Abéché was also selected because of its low seismic noise characteristics and because of the availability of competent operating personnel.

Location

The location of the Abéché station on the African continent is shown on an outline map in Figure 1 together with the locations of other stations on the African continent. Many of these stations are not currently operational. The coordinates and elevations of the instrumentation at Abéché are given in Table I.

Table I

STATION	LONGITUDE	LATITUDE	ELEVATION
Abéché Main	20° 50' 40" E	13° 49' 38" N	550 Meters
South Satellite	20° 51' 42" E	13° 39' 12" N	520 "
West Satellite (old)	20° 37' 48" E	13° 44' 12" N	498.5 "
West Satellite (new)	20° 42' 07" E	13° 50' 46" N	—

General Description

a. Customs and Immigration Information

All persons entering Chad require a visa available from the Chadian embassy in Washington or at the United Nations in New York. Chad imposes a 40% import duty on all items manufactured in France and a 60% import duty on all items manufactured in other parts of the world. To avoid this, all equipment and supplies for the station were imported through the United States embassy as embassy supplies which are free from import duties.

b. Air Transport

Abéché is located in the eastern part of Chad approximately 670 km air line distance east of Fort Lamy, the capital of Chad. Fort Lamy is easily accessible by air from Paris. There are at present 5 jet flights per week nonstop from Paris using DC-8's or Boeing 727's operated by Air Afrique or UTA. There are two flights per week scheduled between Fort Lamy and Abéché via an Air Tchad DC-3 but this service is extremely unreliable. Abéché has an airstrip about 7050 ft. long paved with macadam. DC-4's have landed there without difficulty in the past.

c. Ground Transport

During the dry season from mid-September to mid-June, it is possible to reach Abéché by road. Eighteen hours of driving time over poor dirt roads are required. Commercial road transport is almost unavailable and is at best unreliable. All of the equipment and supplies for the present station have been brought in by air. During the rainy season from mid-June to mid-September, the roads are closed and Abéché is isolated except for the air service.

d. General Information

The European community in Abéché is composed of approximately 50 persons of whom almost all are French technical aid personnel. French is the official language of the country and the only language spoken in Abéché. The European personnel import

most manufactured items and luxury food items such as cheese, butter, etc. There is one general store for both food and hardware, but only basic items are available. Abéché has a combined post office, telephone and telegraph service which is operated by the government (similar to the PTT in France). Telegrams and mail, incoming and outgoing, are undoubtedly read by government officials. Mail service from New York to Abéché requires 14 days, parcel post takes one month and air freight generally requires six weeks. There are no banks in Abéché and no facilities for changing traveler's checks. 220-volt, 50-cycle AC power is available in the town, but not at the seismograph station. A cost figure of \$20,000 has been quoted for bringing AC power to the station. There is running water at a few (i. e. , 3 or 4) houses in Abéché but water is carried to most other houses. Water cost is about \$1.00 per cubic meter. Gasoline is usually available at a cost of about \$1.00 per gallon although at present the borders of Chad are closed and gasoline is generally unavailable. Bottled gas is obtainable intermittently in small containers in Abéché. Labor (unskilled) is available and cheap, i. e. , \$12/month. The standard workday is generally from 7 a. m. to 12 noon and 4 to 6 p. m. An aerial view of Abéché is shown in Figure 3.

#### Installations and Instrumentation

##### a. Buildings

The main station at Abéché is shown in Figures 4 through 11. The land, buildings, office furniture, etc. are all the property of ALPENS.

b. Short-period seismograph system

The output of the short-period seismometer is fed into a short-period amplifier whose output is split and fed into a tape recorder and a short-period galvanometer whose motion is recorded photographically on a drum recorder. Each of these units will be discussed separately below.

1) The short-period seismometers are Benioff portable units manufactured by the Geotech Division of Teledyne Industries. The vertical unit is Model 4681A and the horizontals are Model 6102A's. A three component system is installed at the main station. The seismometer free period is one cycle per second. All eight of each seismometer's coils are connected in series and an external damping resistance of 1200 ohms is utilized. Complete descriptions of these units are available in the manuals published by the Geotech group.

2) The short-period amplifiers originally installed at the Abéché main station were those described in a paper by Thanos entitled "A Low Noise Transistorized Seismic Amplifier." This paper was published in the Bulletin of the Seismological Society of America volume 54, Number 1 in February 1964. A complete description of those amplifiers is given in that publication. In March 1966, when the satellite stations were established at Abéché, the short-period amplifiers at the main station were replaced with units similar

to those operated at the satellite stations. A schematic diagram of these amplifiers is presented in Figure 12 and the frequency response of these units is presented in Figure 13. The gain is fixed at 8500 in the frequency band of interest.

3) The output of the amplifiers is fed through an attenuator network to a short-period galvanometer Model GS-250 manufactured by the Earth Sciences Division of Teledyne Industries. These galvanometers are operated at a free period of 0.2 seconds and have a sensitivity of 0.035 microamps/mm at a one meter focal length. The length of the optical arm used at Abéché is 50 cm. The motions of the galvanometers are recorded on Sprengnether Instrument Company Model 6100 three component Autocorders. These units record at a 60 mm/min rotation rate and 2.5 mm/revolution translation rate. Records are made on 100 foot rolls of photopaper and are changed and processed once a week. A typical magnification curve for the photographic recording short-period system is given in Figure 14. With an amplifier gain of 8500 and a galvanometer sensitivity of 0.07 microamp/mm at a 50 cm focal length, the short-period photographic instruments at the main station have a magnification of 112,000 at one cps. This figure is based on the seismometer output, which was found to be 1.35 mv for a weight lift of 200 mgr. and using a formula for magnification as given in the seismometer manual. Due to differences in the telemetry gain, the magnifications of the satellite seis-

ometers are different from that of a seismometer at the Abéché station. Table II gives the magnification (from earth amplitude to trace amplitude at a one cps earth motion) for each of the nine short-period seismometer systems which record photographically.

Table II

STATION		MAGNIFICATION AT 1 CPS	MAXIMUM MAGNIFICATION
Abeché	Z(vertical)	112,000	369,600
	NS	112,000	369,600
	EW	112,000	369,600
West Satellite	Z	68,000	224,400
	NS	65,000	214,500
	EW	52,000	204,600
South Satellite	Z	46,000	151,800
	NS	66,000	217,800
	EW	68,000	224,400

c. Long-period system

This system is, at present, a low gain wide band system. The output of the seismometers is split and one part is recorded by long-period galvanometers on photographic paper. The other part of the signal is amplified and recorded directly on magnetic tape.

1) The vertical long-period seismometer currently in use is the Sprengnether Instrument Company model operating at a free period of 15 seconds. The horizontals are manufactured by the

Earth Sciences Division of Teledyne Industries Model SH-291 and are also operated at a free period of 15 seconds. The horizontals have been modified to accommodate Sprengnether coils and magnets to obtain similar constants except for the mass differences. A free period of 15 seconds was chosen to simplify maintenance during the large temperature variations between day and night. Specifications on these units may be obtained from the manufacturer's catalog.

2) Amplifiers. Three channels of preamplification are required to bring the three-component, long-period signals up to a level suitable for driving the record oscillators of the tape recorder. The preamplifiers must be able to accept low impedance inputs (i. e. ,  $\sim$  500 ohms) and, of course, the input and output of each pre-amplifier must be completely isolated to prevent feedback to the photographically recording monitor circuit. The amplifier selected for this purpose was a Minneapolis-Honeywell Deviation Amplifier having the following specifications:

**Environmental Limits:**

Ambient temperature: 40° to 120° F  
Relative humidity: 10% to 95%

**Input:**

Minimum span:  $\pm$  25 microvolts  
Minimum detectable signal:  $\pm$  0.5 microvolts  $\pm$   $0.5 \times 10^{-11}$  amperes  
Resistance: 40,000 ohms at a gain of 10,000  
                  10,000 ohms at a gain of 40,000  
Gain: Adjustable 7500 to 100,000  
Stability: 2% at a gain of 10,000

Output:

Zero Stability:  $\pm 0.5$  microvolt for an 8-hour period

Capability:  $\pm 4$  volts into 2000 ohms or more

Impedance: 250 ohms at a gain of 10,000

1000 ohms at a gain of 100,000

Ripple: 1% RMS of the direct output voltage

Zero Stability:  $\pm 0.5$  microvolts peak-to-peak over a 0 to 5 cps band pass. In general, the measured noise level was about  $\pm 0.15$  microvolts peak-to-peak over this pass band.

The above seismometer-amplifier combination provides a displacement response, which with increasing period falls at 6 db/octave from approximately 5 cps to 15 seconds and then drops at 18 db/octave for periods greater than 15 seconds.

3) The seismometer outputs are fed into Model GL-261 long-period galvanometers manufactured by Teledyne and operated at a free period of 100 seconds. These units have a frequency response like that of the 15-80 systems discussed in Sutton and Oliver's "Seismographs of High Magnification at Long Periods" published in *Annales de Geophysique* (1960). The magnification at present in the frequency band between 15 and 90 seconds is 1500. The galvanometer motions are recorded on a Model 6700 Autocorder at a rotation rate of 15 mm/min and a translation rate of one cm/revolution. The optical arm length is one meter.

d. Magnetic Tape Recording

The seismic signals from the main station and the two satellite stations are recorded on a Geotech Model 21022 14 channel one inch recorder operating at .06 inches per second. The center

frequency is 54 cps and  $\pm 40\%$  deviation corresponds to  $\pm 1.4$  volts.

The channel designations on the tape are listed in Table III.

Table III

Channel	Component		Station
1	North-South	SP	West satellite
2	East-West	SP	" "
3	Vertical	SP	" "
4	North-South	SP	South satellite
5	Vertical	SP	" "
6	East-West	SP	" "
7	Compensation	—	—
8	North-South	SP	Abéché main
9	Vertical	SP	" "
10	East-West	SP	" "
11	North-South	LP	" "
12	East-West	LP	" "
13	Vertical	LP	" "
14	Time	—	—

The response characteristics of the long-period system as recorded on magnetic tape are given in Figure 27.

e. Calibration

Calibration step functions of voltage are applied to the short and long-period seismometers daily at the main station. In

addition, impulses of voltage are applied daily to the long-period instruments to assure good calibration at the shorter periods.

Calibration step functions are applied to the seismometers at the satellite stations once a week. Weight lift calibrations are performed every two to three months.

Sine wave calibrations are performed once a year.

f. Time reception and generation

Time for all the LGO recordings is provided by a Sprengnether TS-100 crystal controlled chronometer. Time checks on 15 mc from Radio Moscow are used to correct the chronometer time to universal time. Time is generally good to about .01 seconds.

g. Telemetry reception facilities

Six eight element Yagi antennas are mounted on two antenna masts to receive the telemetry signals from the remote sites. The signals are converted to a 6 mc i. f. and then the pulses are shaped and applied to the recording heads. The signals are discriminated also and fed to 0.2 sec UED Model GS-250 galvanometers whose motion is recorded on three component autocorders. One three component Autocorder is utilized to record the signals from each satellite. A schematic diagram of the pulse shaping circuitry is presented in Figure 15. The circuit for rebuilding the square wave for application to the recording heads is shown on the right hand side of Figure 16.

h. Power facility

A 5KVA generator producing 220v 50 cps A. C. is operated during the working day at Abéché. This provides the power for battery charging, lights, air conditioning, etc. This is not operational for about 16 hours per day and during that period, the entire station operates on + 12v D. C. Four 200 ampere hour batteries provide the D. C. power.

Due to daily battery charging, the recorders are operated by a higher voltage during the day than during the night. Special constant speed motors are used for driving the Sprengnether drum recorders. Power limitations are also preventing the use of most desirable types of tape recorders.

Satellite Stations

Location

The locations of the two satellite stations are given in Table I and the locations relative to the main stations are shown in Figure 2.

General Description

Each satellite consists of a three component set of short-period instruments housed in a surface instrument vault like those shown in Figures 17, 18 and 19. The amplifiers, telemetry equipment and power generation equipment is housed in a brick building at each satellite. Three telemetry antennas are mounted on a 50 ft. mast near

the instrument building. This gives line-of-sight transmission; however, during strong winds, the antennas move sufficiently to cause momentary signal dropouts. Photographs of the satellite areas are presented in Figures 20 to 24.

#### Instrumentation

The short-period seismometers installed at each satellite station are the same model as those used at the main station.

The short-period amplifiers installed at each satellite station are the same units as those installed at the main station. The schematic diagram of this amplifier is presented in Figure 12 and its frequency response is presented in Figure 13.

#### FM modulation and Telemetry

Because the telemetry system is somewhat unusual, a brief description of the units utilized follows.

The output of each amplifier is fed into a voltage controlled oscillator (VCO) card which was taken for the magnetic tape recorder at the central station. Additional  $\pm 9$  volt regulator cards were purchased and installed at the outlying stations. This circuit is shown in the left hand side of Figure 16. At this point, the seismic signal is contained in a 54 cps center frequency FM carrier whose  $\pm 40\%$  deviation points correspond to  $\pm 1.4$  volts of signal. The output of the VCO is then applied to the input of the 150 mc (nominal) telemetry transmitter. The circuit diagram of this unit is presented in Figure 25.

The 54 cps carrier of the VCO is applied to a switching transistor which conducts when the input voltage reaches a certain value either positive or negative. The 54 cps sine wave is thus converted into a 108 cps square wave. However in each cycle, the switching transistor is quenched after approximately 1/8 of the cycle. Thus at this point, the carrier looks like the following:

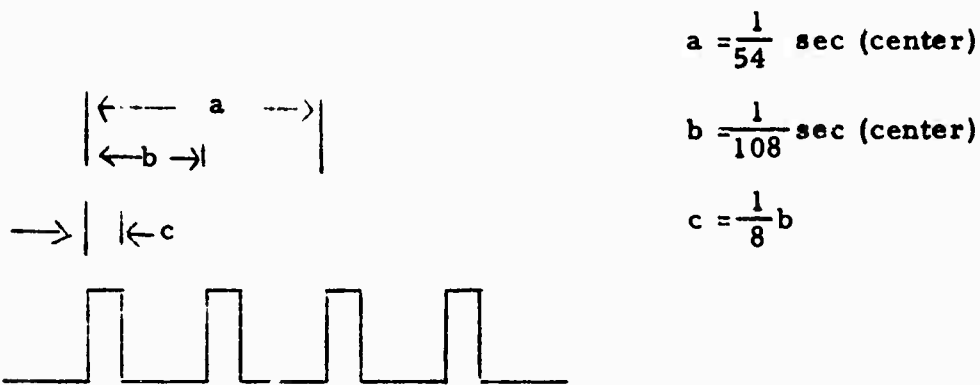

The output of the switching transistor circuit is used to turn the B+ supply of the transmitter off and on. Thus the transmitted signal is a continuous wave (cw) signal of 150 mc (nominal) that is keyed at a center frequency of 108 cps. By keying the transmitter for only 1/8 of the cycle, the peak power can be kept high while the average power and thus the power consumed can be kept small. The output of each transmitter is applied to an 3 element Yagi antenna cut for the specific frequency of the transmitter. The transmitter frequencies used are given in Table IV.

Table IV

Satellite	Component	Frequency
South	North-South	149.0 megacycles
South	East-West	151.0 megacycles
South	Vertical	150.0 megacycles
West	North-South	149.5 megacycles
West	East-West	150.5 megacycles
West	Vertical	151.5 megacycles

The total power consumption at each satellite is approximately 3 watts. A complete set of spare telemetry transmitters is kept at each satellite station. A complete set of spare telemetry receivers is maintained at the central stations.

A simple flip-flop circuit at the output of the receiver is all the electronics necessary prior to placing the FM signal on the record heads at the central station.

Power supply

Two 200 ampere hour batteries supply the power at the outlying stations. These require recharging once a month. A Kohler gasoline operated charger has been placed at each site.

Detection Capability

The minimum detectable signal observable at this station has not been studied. To obtain some idea of this function, however, the photo-

graphic records only at the main station at Abéché were studied for a period of 42 days were studied. During this interval 475 earthquakes were reported by the United States Coast and Geodetic Survey (USCGS) of which 183 were recorded at Abéché. In Figure 26, a plot of the minimum magnitude detected at the 90% level as a function of epicentral distance is presented.

A number of qualifications must be mentioned in connection with the use of this graph. Among these

- 1) Only events reported by the USCGS are considered.
- 2) Only events with assigned magnitudes are considered.
- 3) The assigned magnitudes themselves are open to some question.
- 4) Only the photographic records at the Abéché central station have been used.
- 5) The instrumental response curves have not been optimized for the noise spectrum at Abéché.

In connection with 1, it is necessary to look at the data further. In a 19 day subset of this data, 203 events were reported of which 61 were recorded at Abéché. During the same period, however, there were 13 major arrivals, 19 definite arrivals, 21 probable arrivals and 27 questionable arrivals observed. Thus at least 53 additional events unreported by the USCGS were recorded. Of the 13 major arrivals, 2 were determined to have occurred in Greece and 2 were observed at Lwiro, Republic of the Congo, indicating a possible Rift Valley origin.

Under item 2 above, during the same 19 day subset of data, 11 events were reported without magnitudes of which 4 were observed at Abéché. These were not included in the plot presented in Figure 26. In connection with item 4 above, the use of the array and the magnetic tape recordings would significantly improve the figures given. In view of all of these considerations, the detection capability indicated in Figure 26 is a very conservative estimate. By utilizing array techniques, shaping the response curves and using greater magnifications, significant improvements can be achieved.

#### Noise Spectrum at Abéché

The spectrum of the microseismic noise at Abéché for a six minute sample of data on 3 May 1966 is presented in Figure 28. This spectrum is corrected for instrument response and represents the data from the short-and long-period vertical seismographs which record photographically. The low noise curve from Brune "Noise at the surface of the Earth" is presented for comparison in this figure. When there are high winds at Abéché (and they are common during the rainy season up to 75 km/hr) the short-period noise level rises to the point where the photographic recordings are not readable. Winds generally last for a three-to-four hour period.

#### Future Plans

Future plans call for the installation of a three component wide band, high gain, long-period system using Phototube amplifiers and

recording photographically and on magnetic tape. These units will be installed in May 1967.

ALPENS has drilled a 50 foot deep 8 inch diameter hole at each station for installation of a shallow array of ALPENS (?) seismometers.

FIGURE CAPTIONS

- Figure 1. Outline map of Africa showing Abéché ABC and other past and present seismograph stations on the African continent.
- Figure 2. Pattern of the seismograph array at Abéché, Chad.
- Figure 3. An aerial view of Abéché. The seismograph station, about one mile from the center of the town, is shown at the lower left of the photograph.
- Figure 4. Front view of the main building at the main station in Abeche.
- Figure 5. Rear view of the main station at Abéché. The antenna mast in the center holds the receiving antennas for the south satellite signals. A six meter communications antenna is seen at the left.
- Figure 6. View of the interior of the main building showing the magnetic tape recorder and control console to the left. Photographic recording is carried out beyond this area.
- Figure 7. A view of the interior of the main building showing the office area of the station.
- Figure 8. The exterior of the short-period vault at the main station at Abéché.
- Figure 9. The exterior of the long-period vault and the main station at Abéché.
- Figure 10. Solar power panels installed at Abéché.

- Figure 11. Telemetry mast and antenna for reception of signals from the west satellite.
- Figure 12. Schematic diagram of the short-period amplifier currently in use at Abéché.
- Figure 13. Frequency response of the short-period amplifier currently in use at Abéché.
- Figure 14. Frequency response for the photographically recording short-period systems at Abéché.
- Figure 15. Pulse shaping circuitry at the central station.
- Figure 16. On the right, the flip flop circuit for changing incoming telemetry pulses to 54 cps square wave. On the left, the FM encoding section of the satellite electronics.
- Figure 17. Surface short-period vault at the old west satellite station.
- Figure 18. Surface short-period vault at the west satellite station.
- Figure 19. Surface short-period vault at the south satellite
- Figure 20. Surface short-period vault at the south satellite opened to show details of construction.
- Figure 21. General view of the west satellite looking east toward Abéché.
- Figure 22. View of the west satellite looking north.
- Figure 23. Close up of instrument shelter at satellite.
- Figure 24. View of the old west satellite.

Figure 25. Schematic diagram of the 150 mc (nominal) telemetry transmitter.

Figure 26. Preliminary estimate of detection capability of a single vertical seismometer recording photographically at Abéché.

Figure 27. Response characteristics of the long-period tape system at Abéché.

Figure 28. Spectrum of the microseismic noise at Abéché.

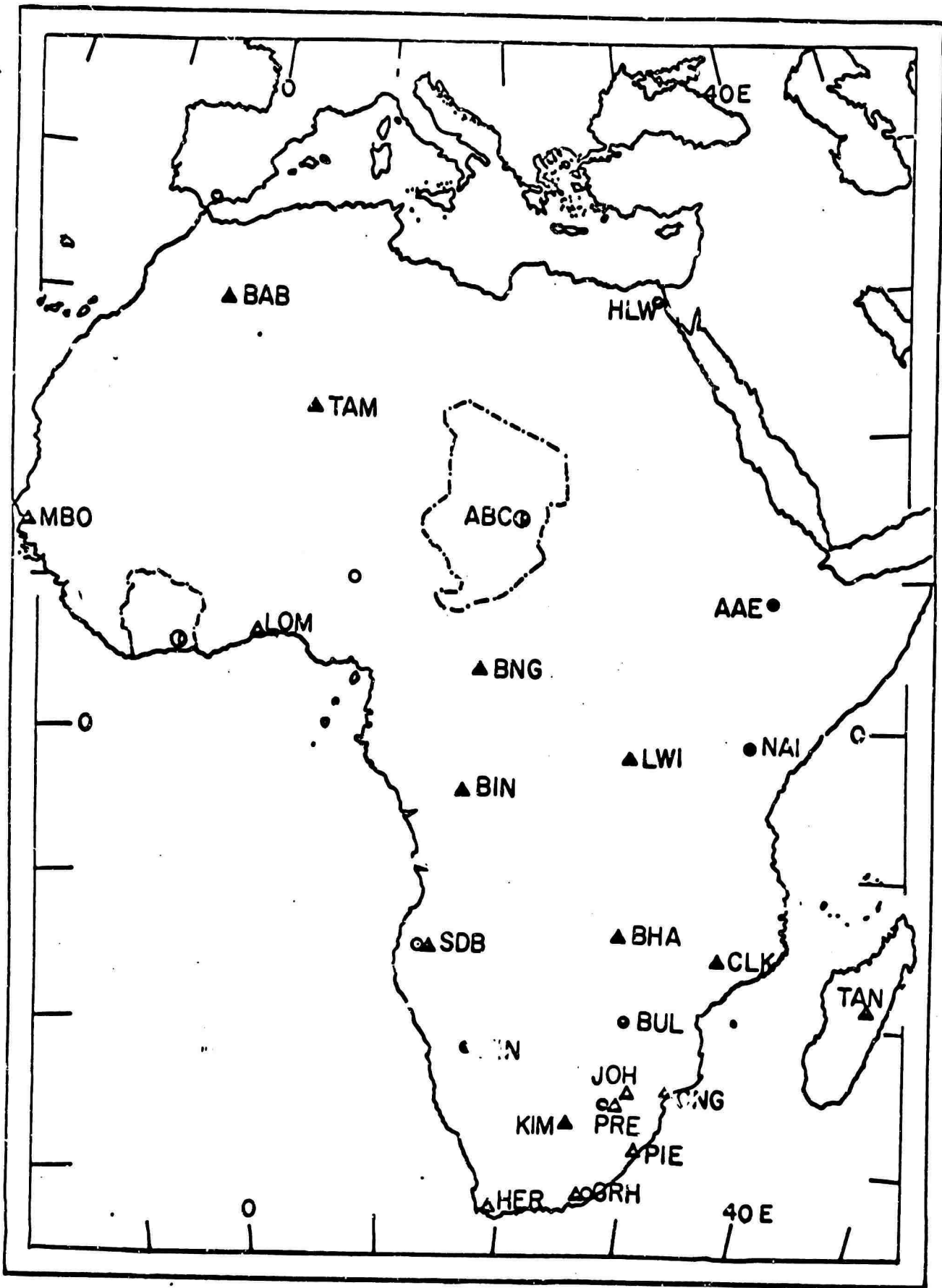

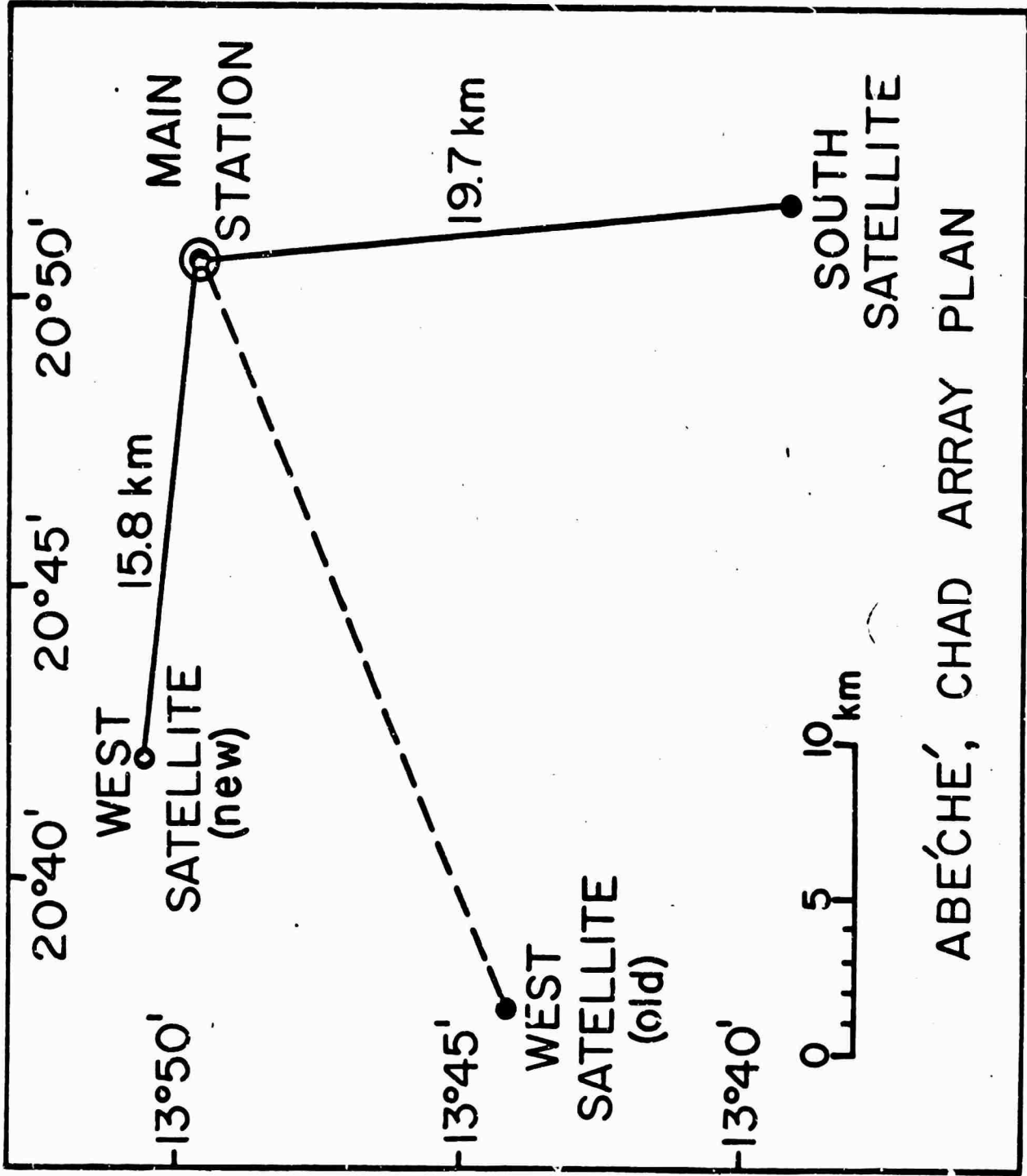

ABEÇHE', CHAD ARRAY PLAN



Figure 3. An aerial view of Abéché. The seismic station, about 1 mile from the center of the town, is shown at the lower left of the photograph.



Figure 4. Front view of the main building at the main station at Abéché.

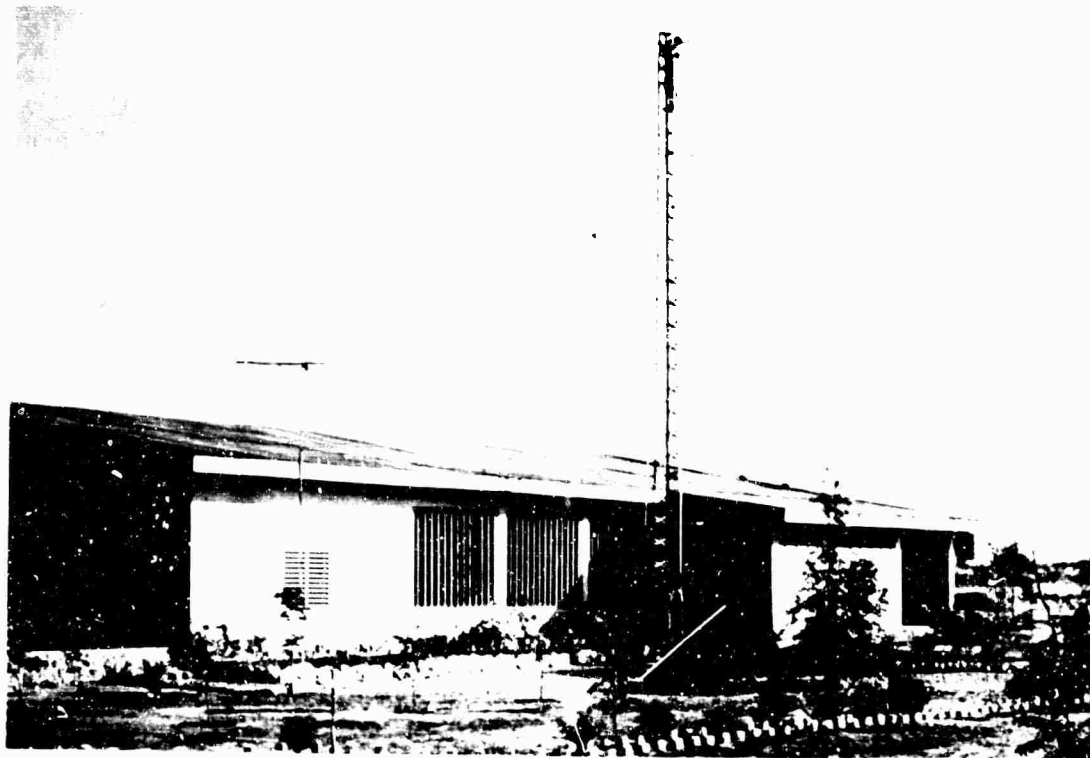

Figure 5. Rear view of the main station at Abéché. The antenna mast at the center holds the receiving antennas for the south satellite signals. A six meter communications antenna is seen at the left.

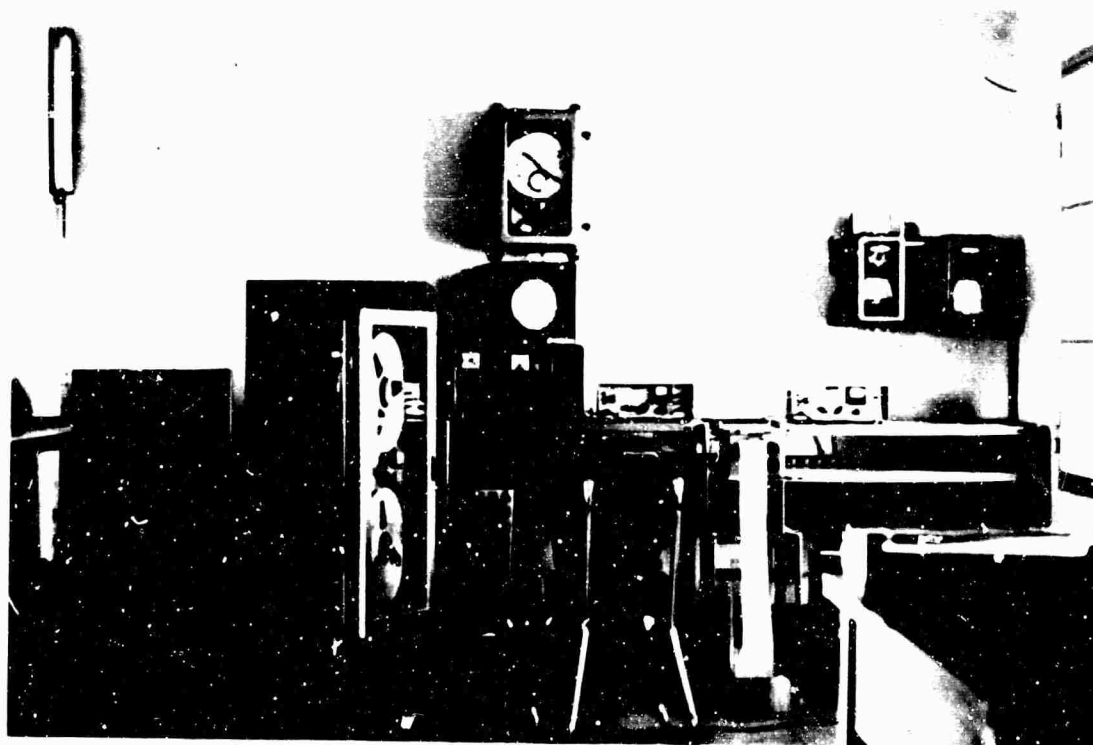

Figure 6. View of the interior of the main building showing the magnetic tape recorder and control console to the left. Photographic recording is carried out beyond this area.

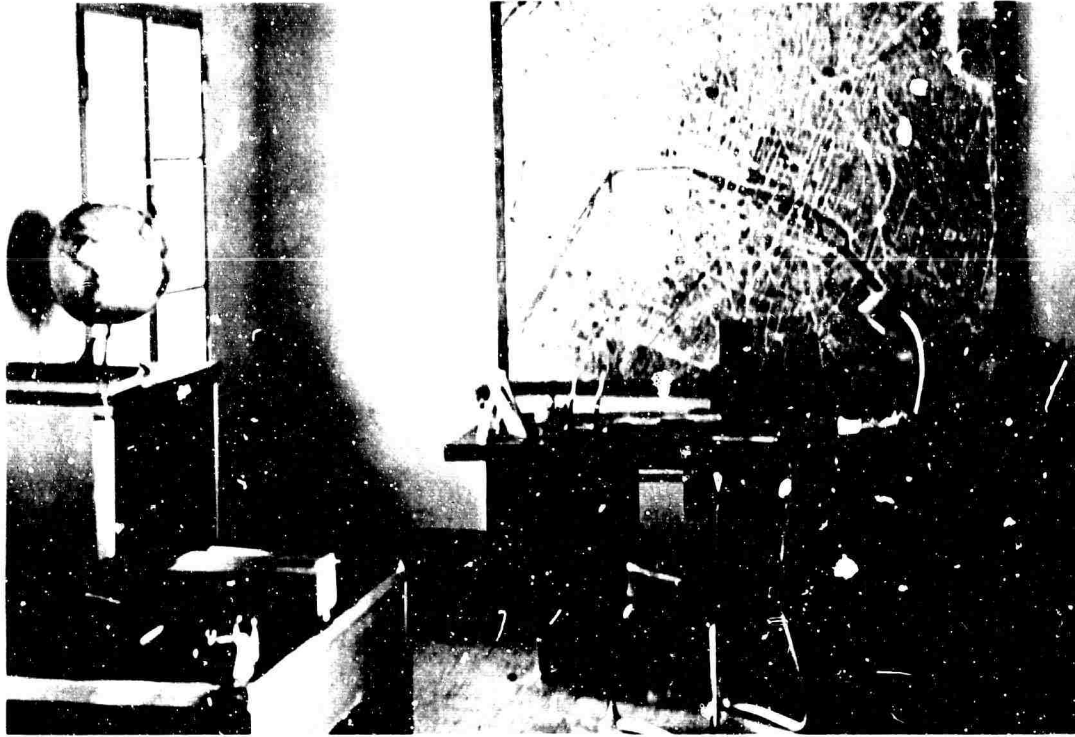

Figure 7. A view of the interior of the main building showing the office area of the station.

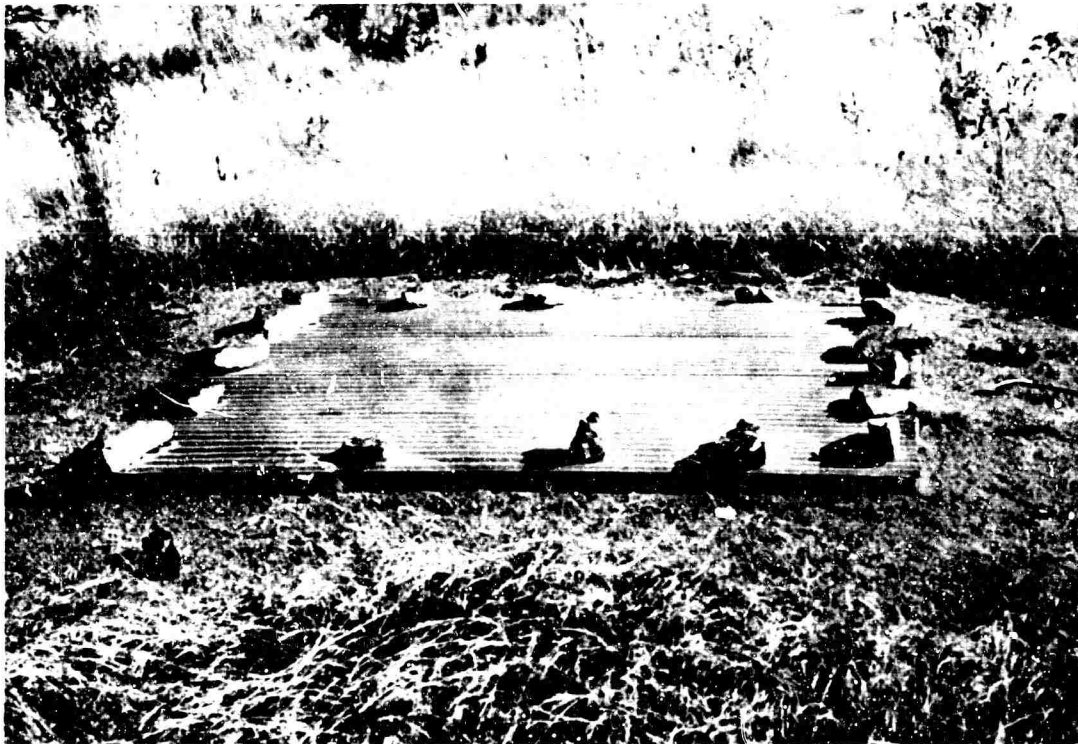

Figure 8. The exterior of the short period vault at the main station at Abéché.

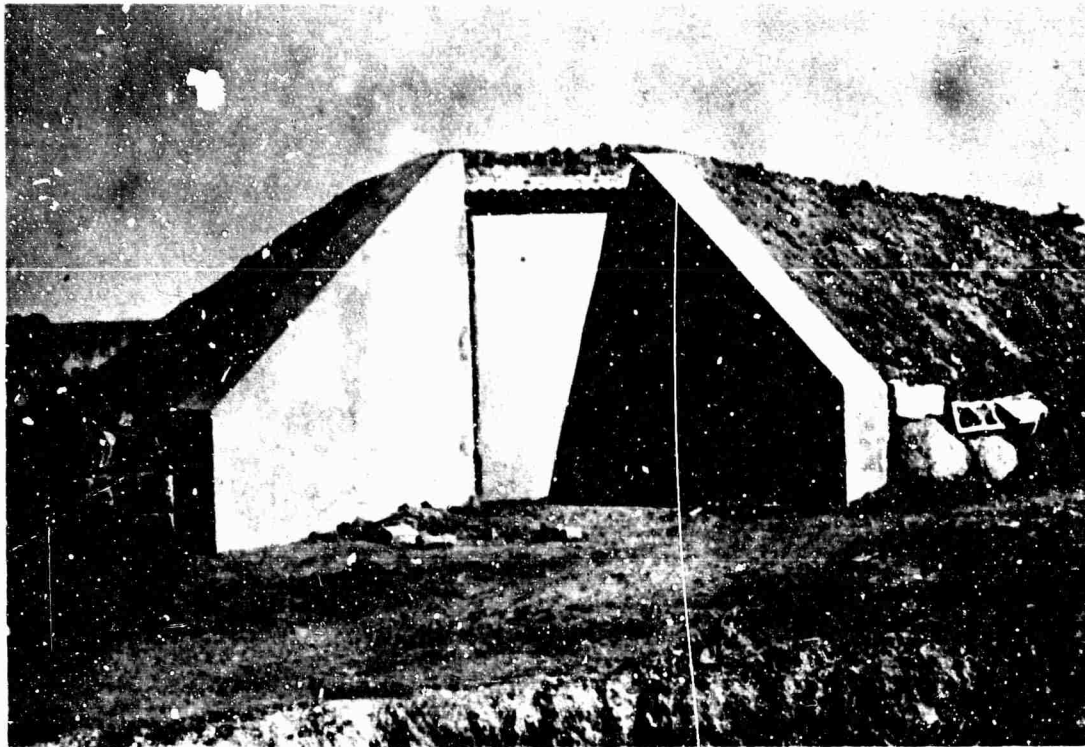

Figure 9. The exterior of the long period vault at the main station at Abéché.

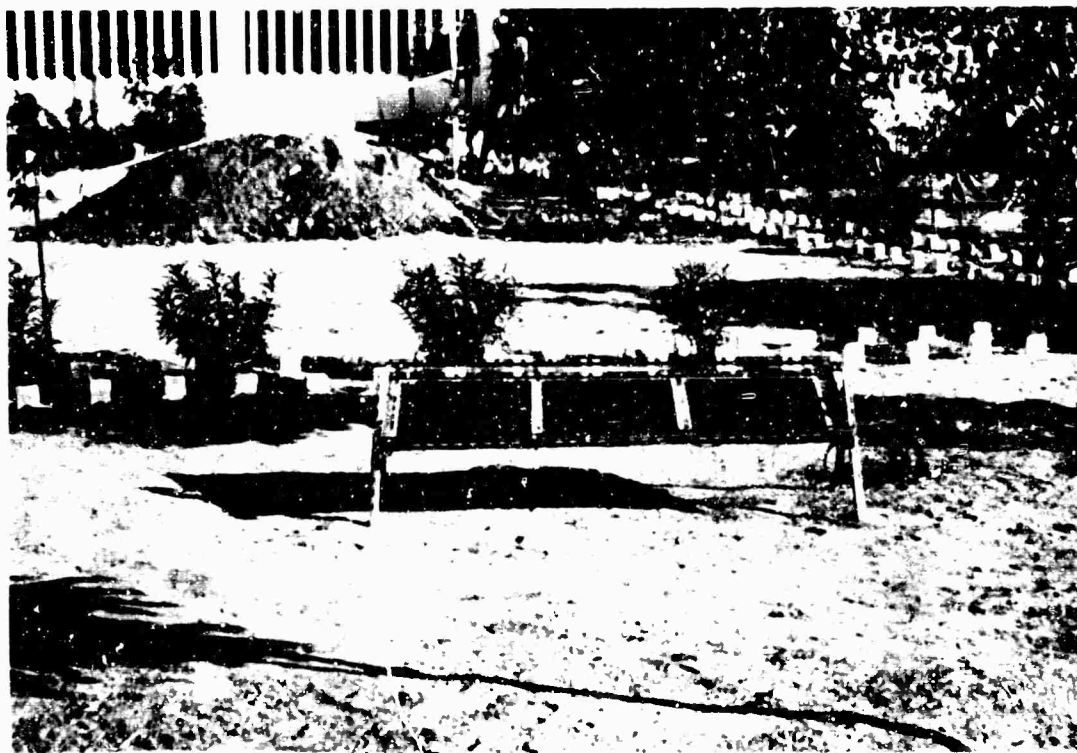

Figure 10. Solar power panels installed at Abéché.

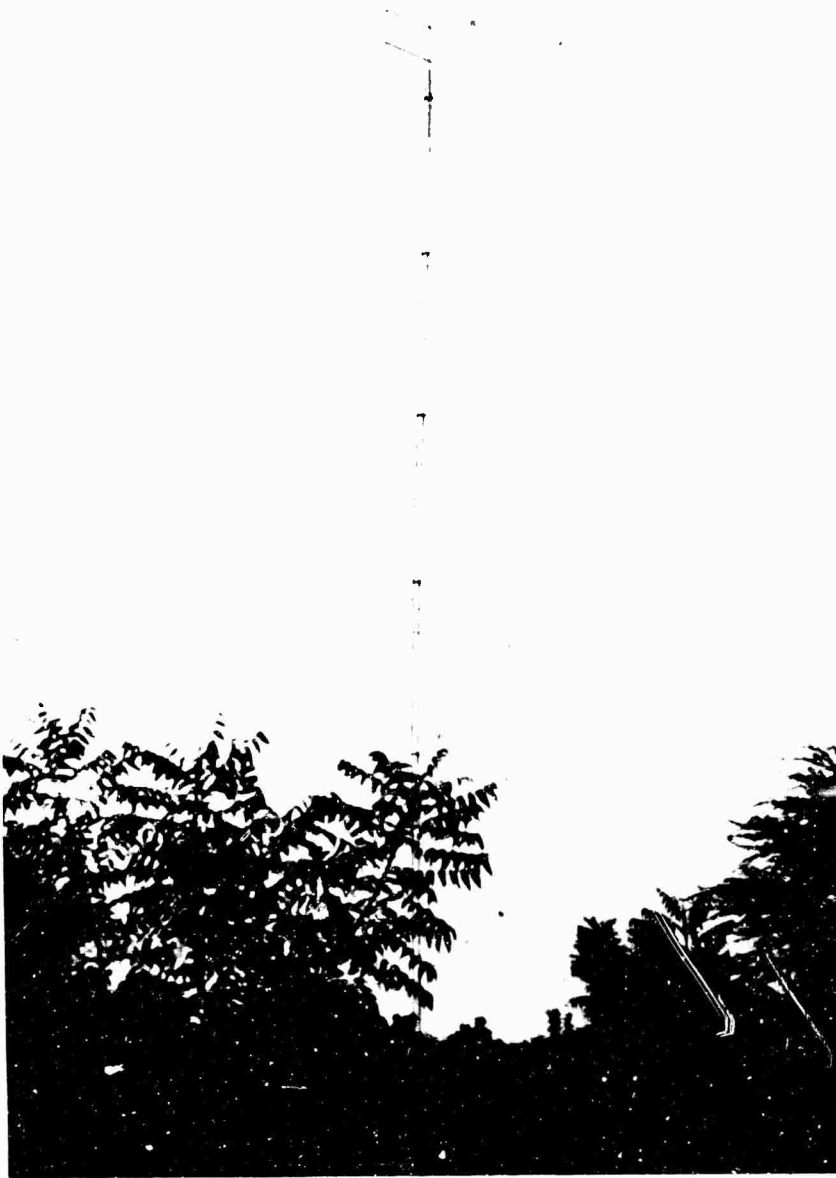
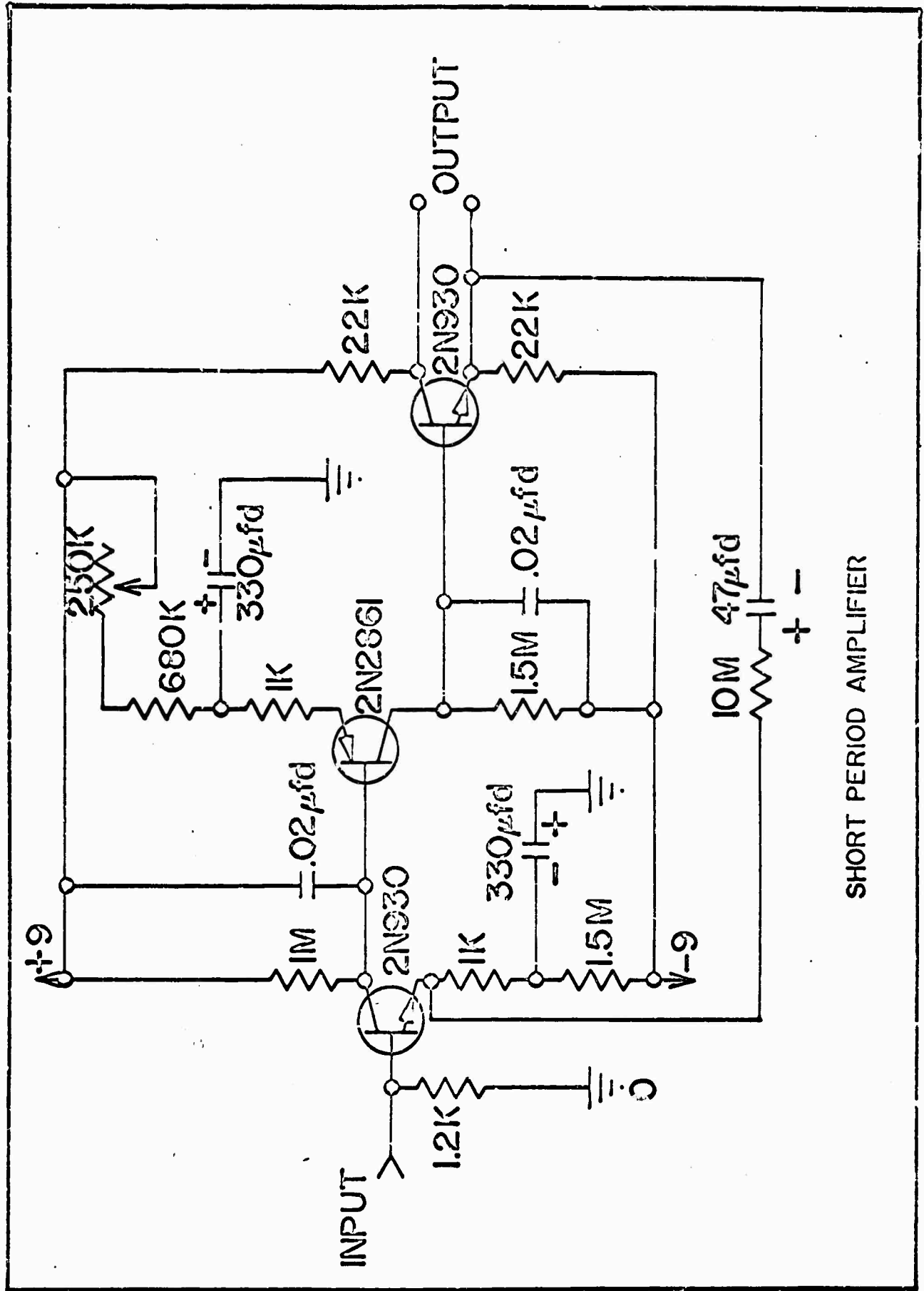
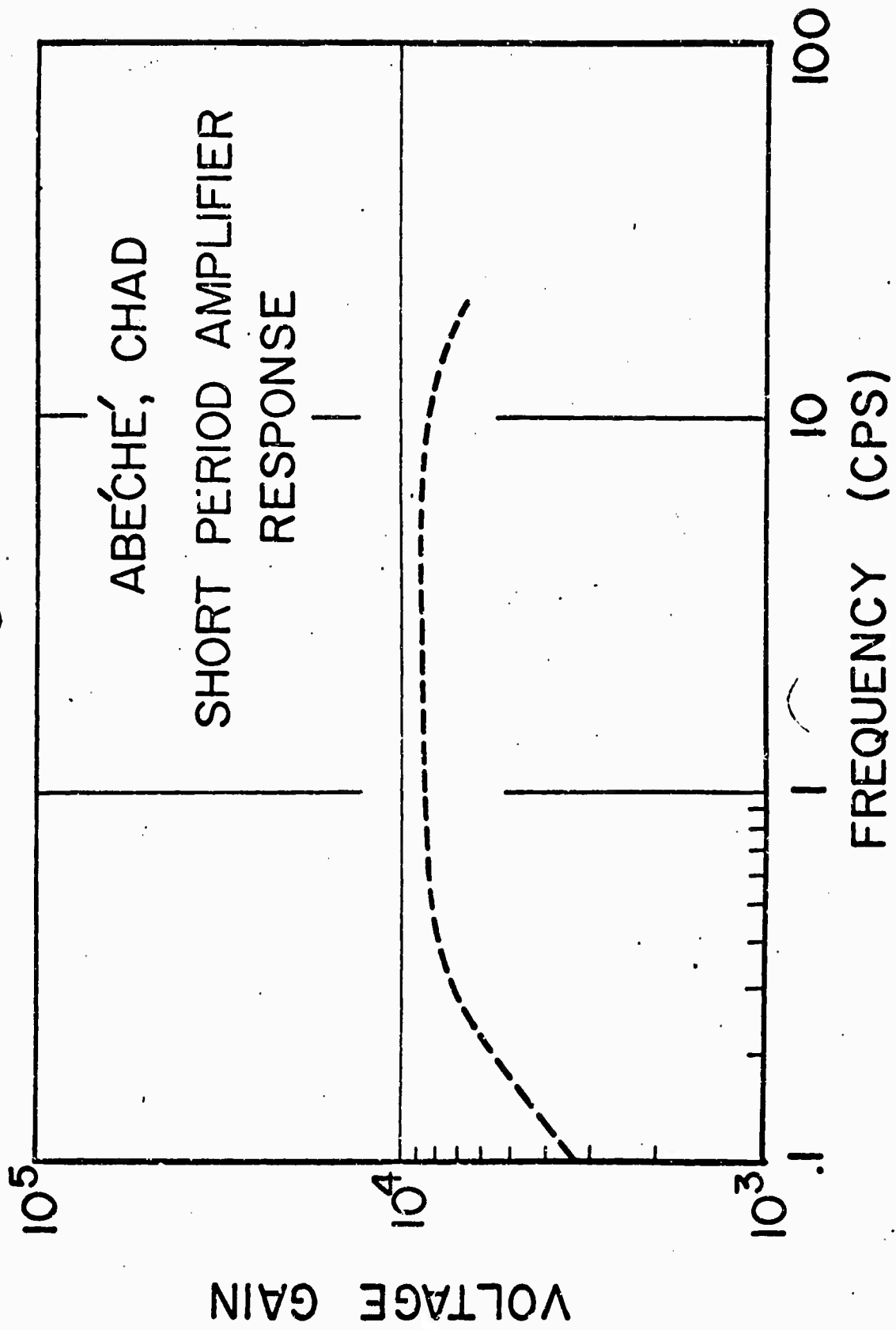
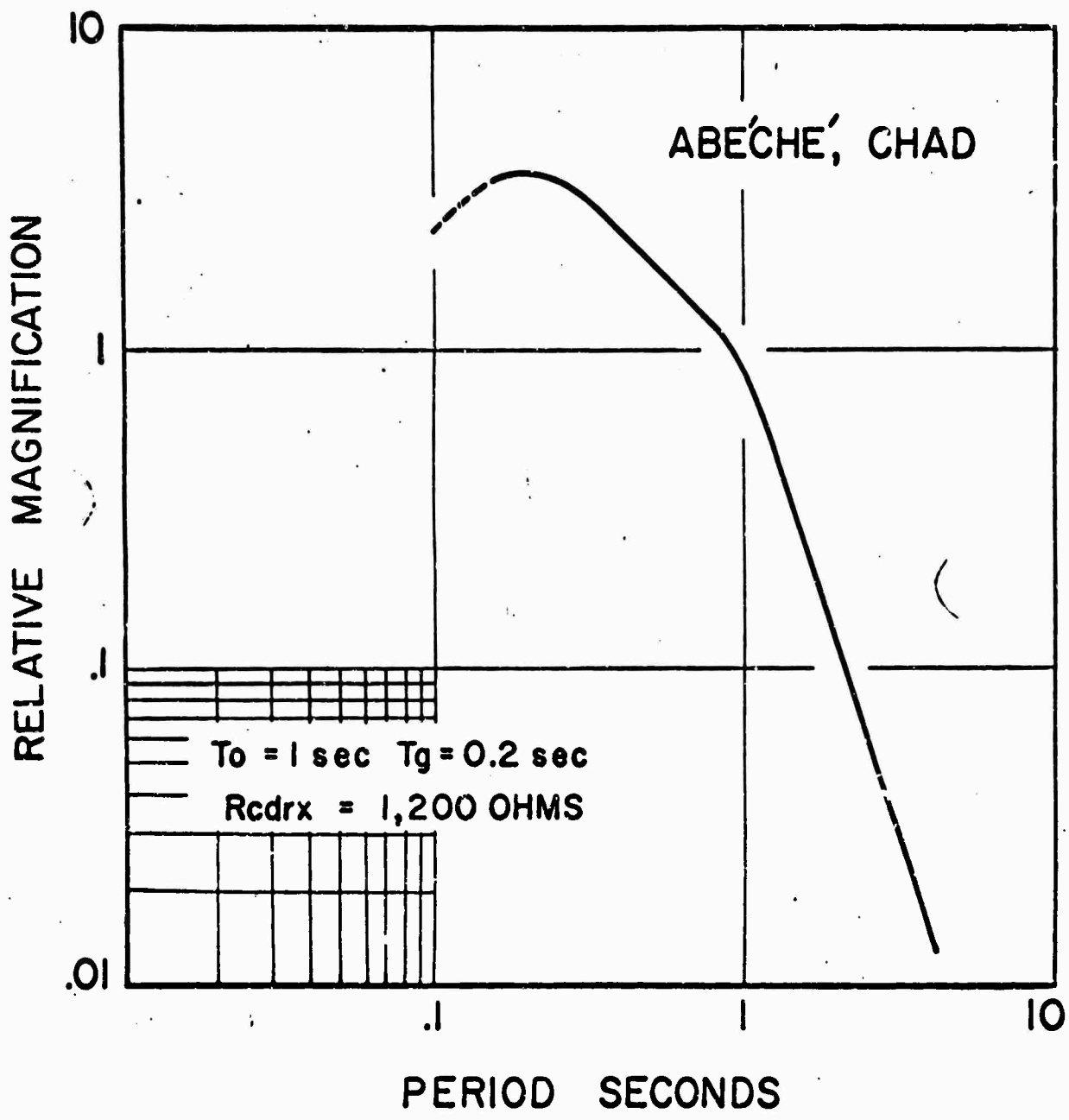

Figure 11. Telemetry mast and antennas for reception of signals from the west satellite station.



SHORT PERIOD AMPLIFIER





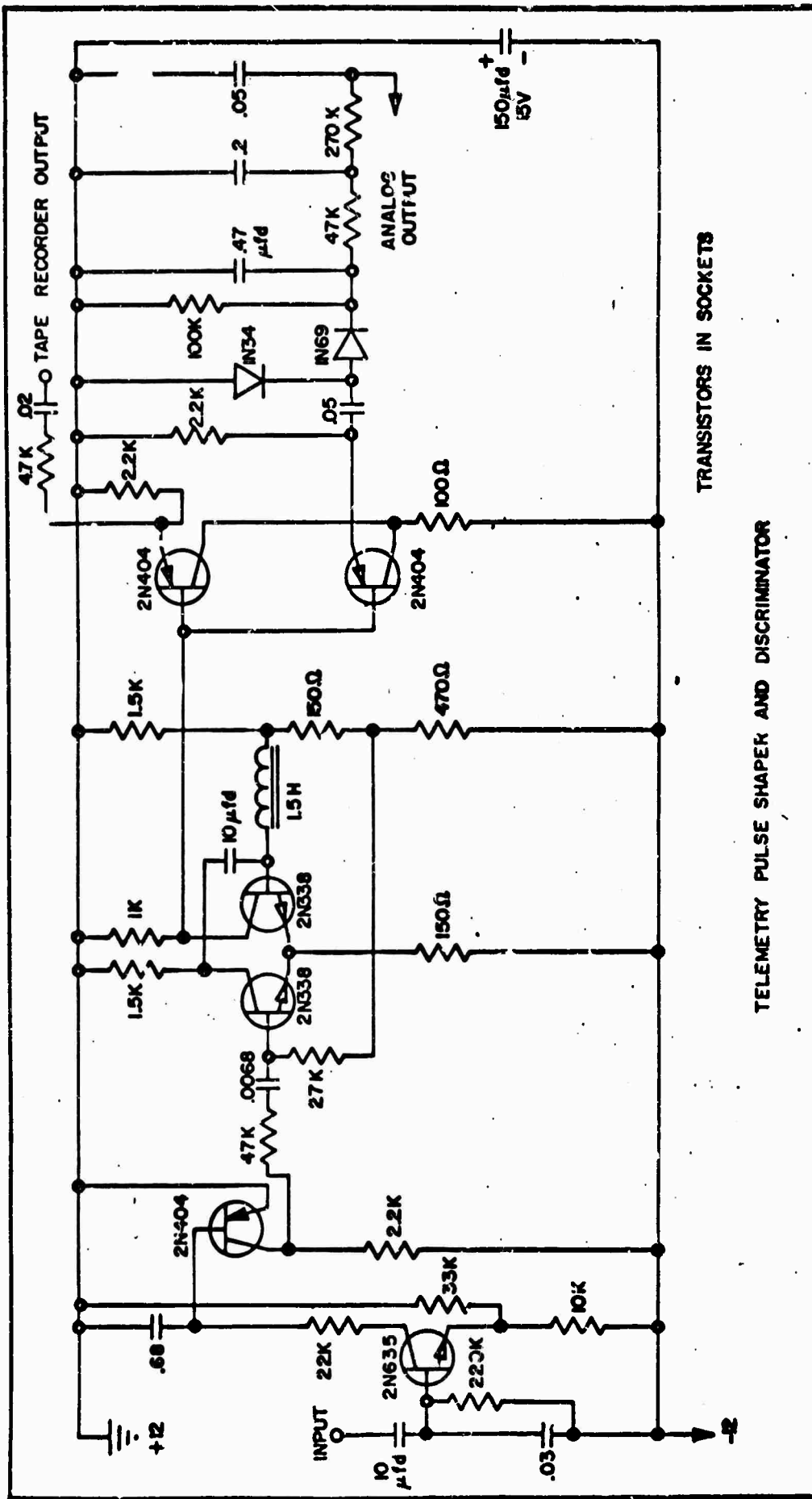

TELEMETRY PULSE SHAPEK AND DISCRIMINATOR

TRANSISTORS IN SOCKETS

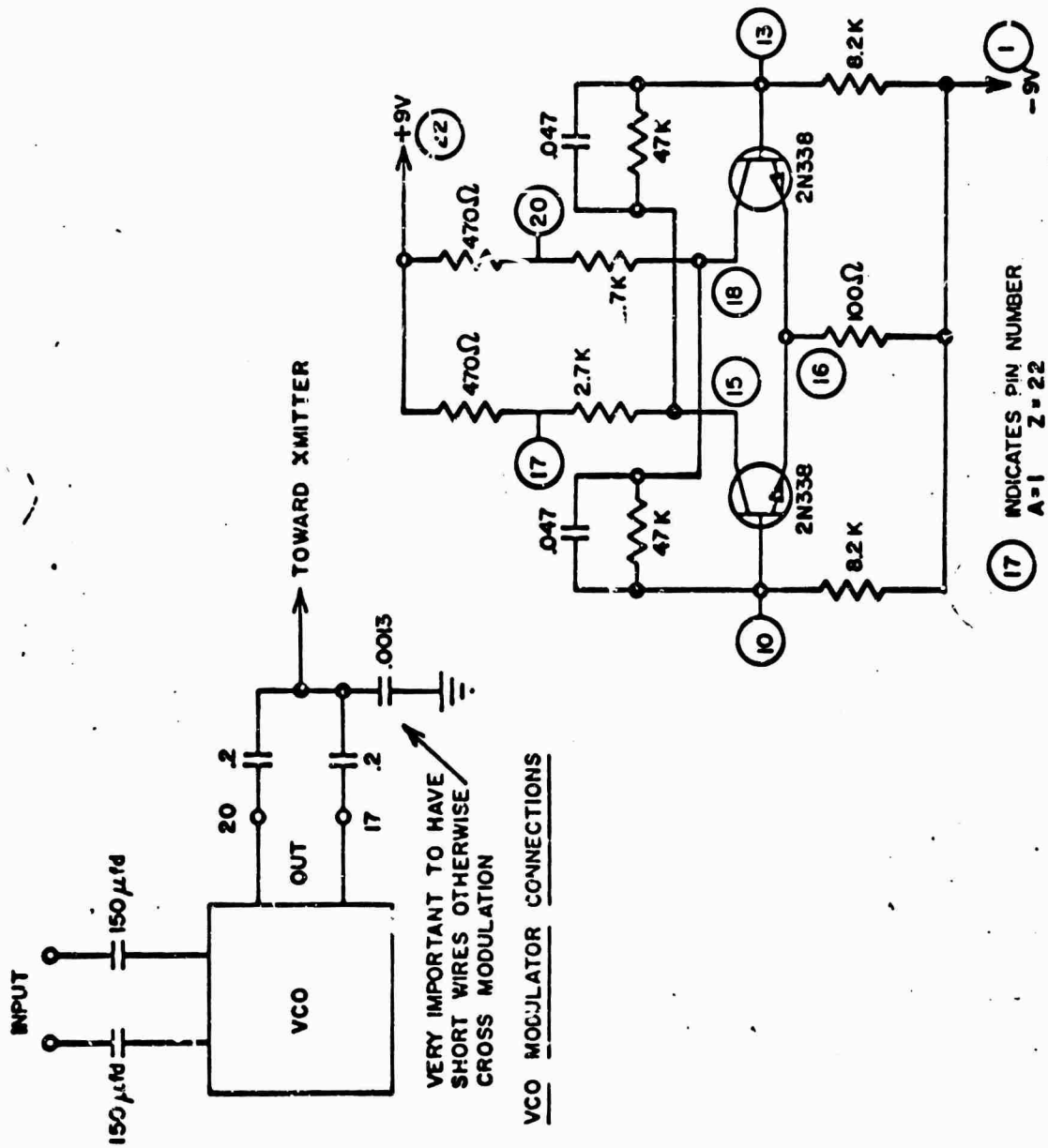

VERY IMPORTANT TO HAVE  
SHORT WIRES OTHERWISE  
CROSS MODULATION

VCO MODULATOR CONNECTIONS

17 INDICATES PIN NUMBER  
A=1 Z=22



Figure 17. The surface short period vault at the old west satellite station.



Figure 18. The surface short period vault at the west satellite station.



Figure 19. The surface short period vault at the south satellite station.

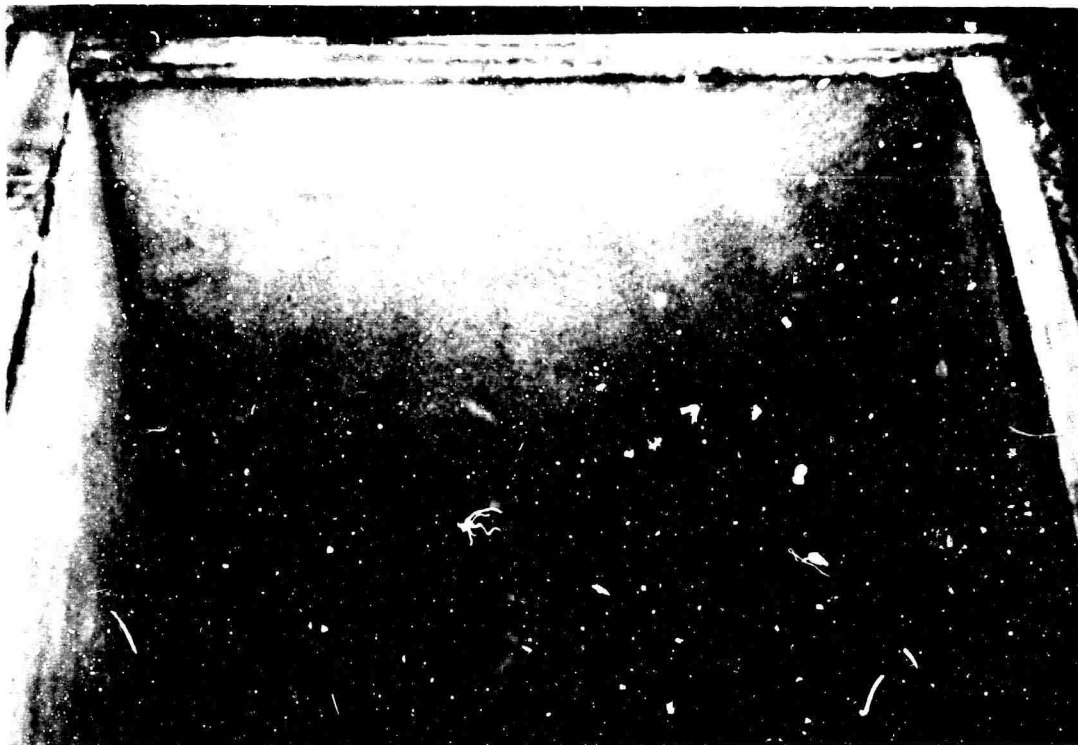

Figure 20. The surface short period vault at the south satellite station opened to show details of construction.

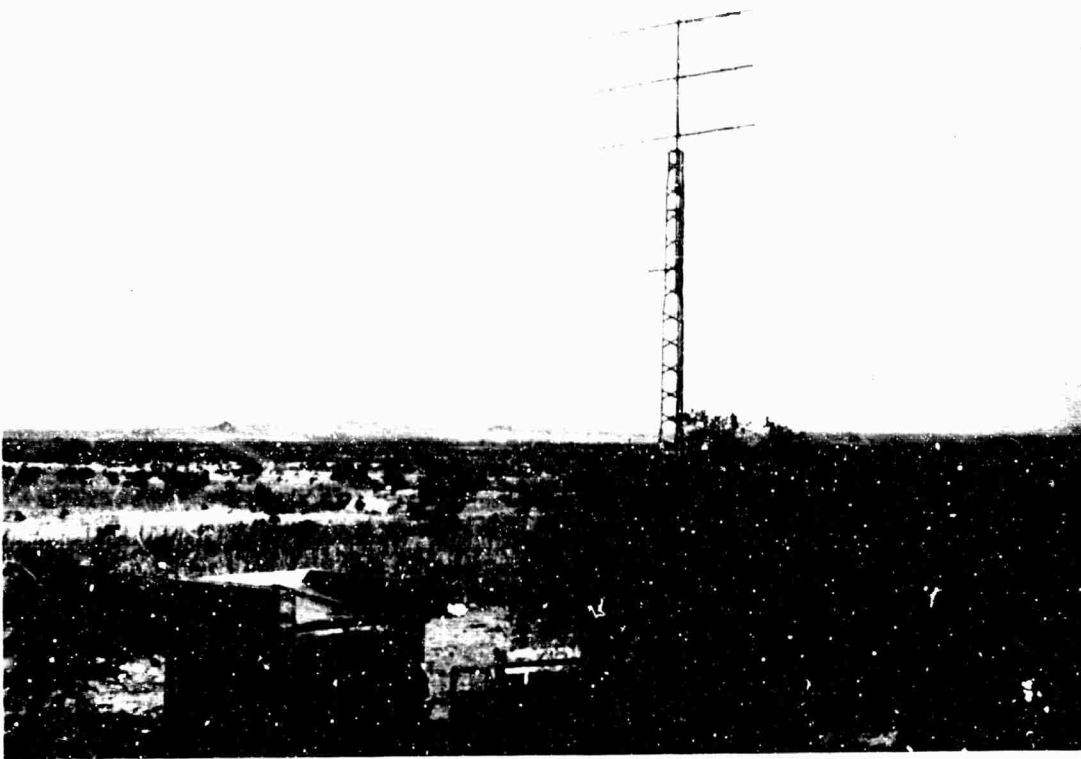

Figure 21. A general view of the west satellite looking east toward Abéché.

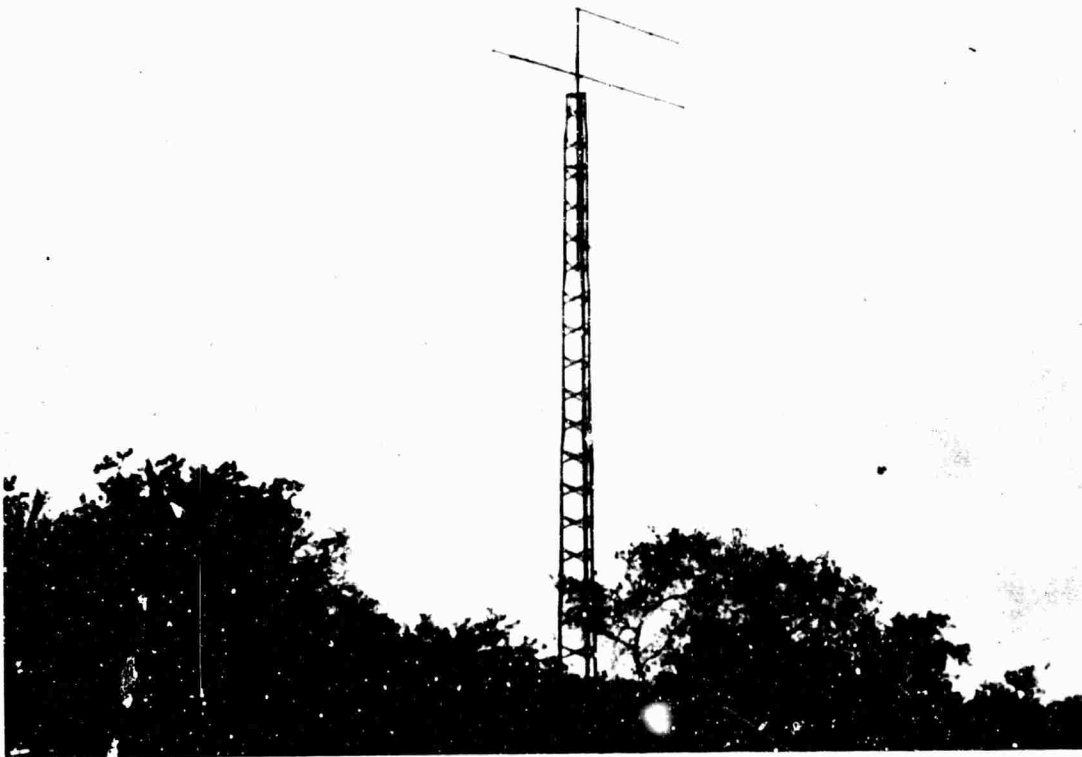

Figure 22. A view of the west satellite looking north.

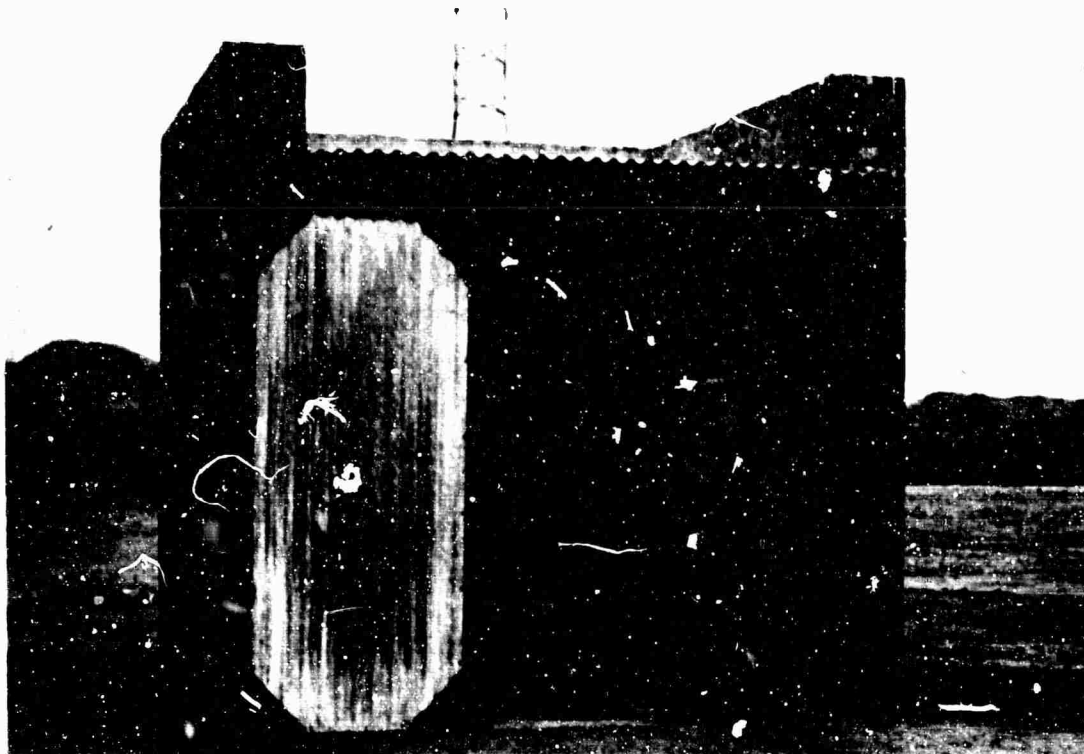

Figure 23. A close up of a typical electronics instrument shelter at the satellite stations.

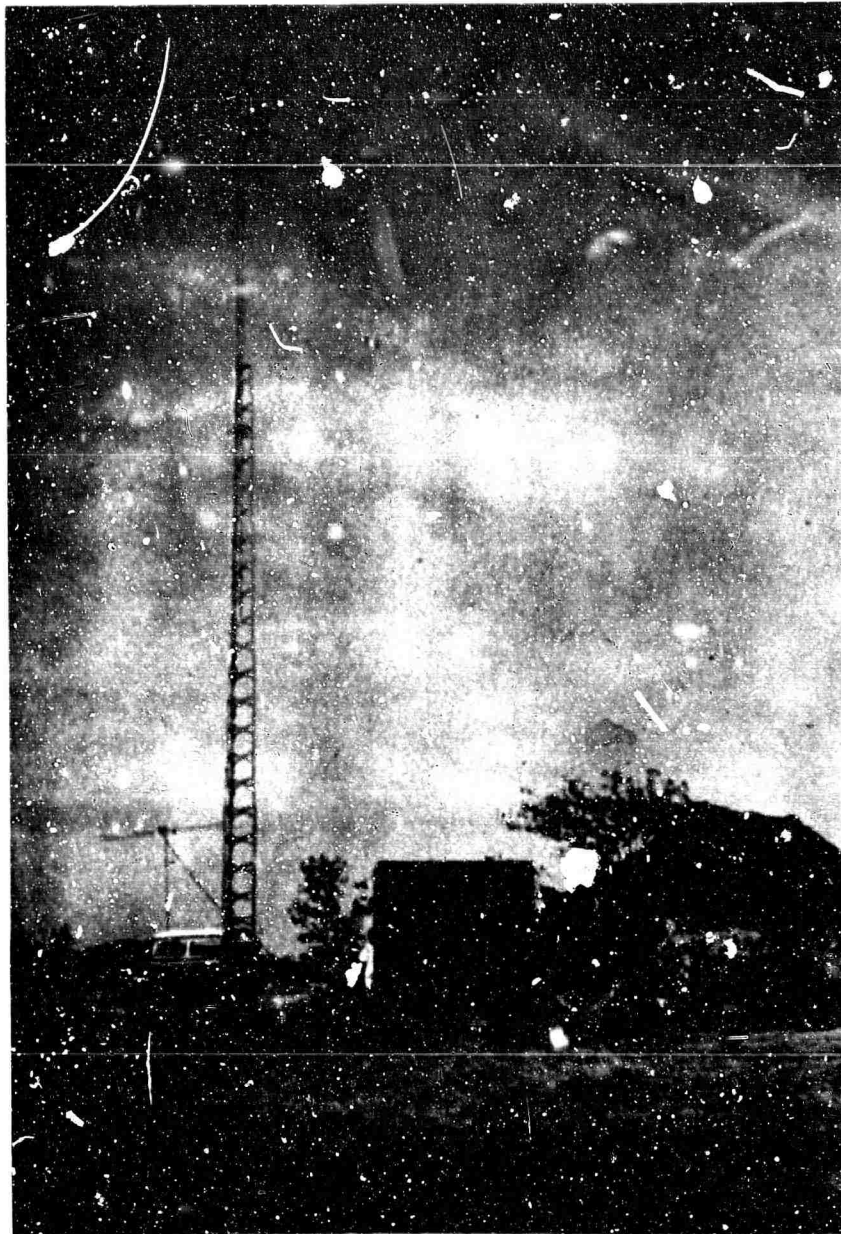
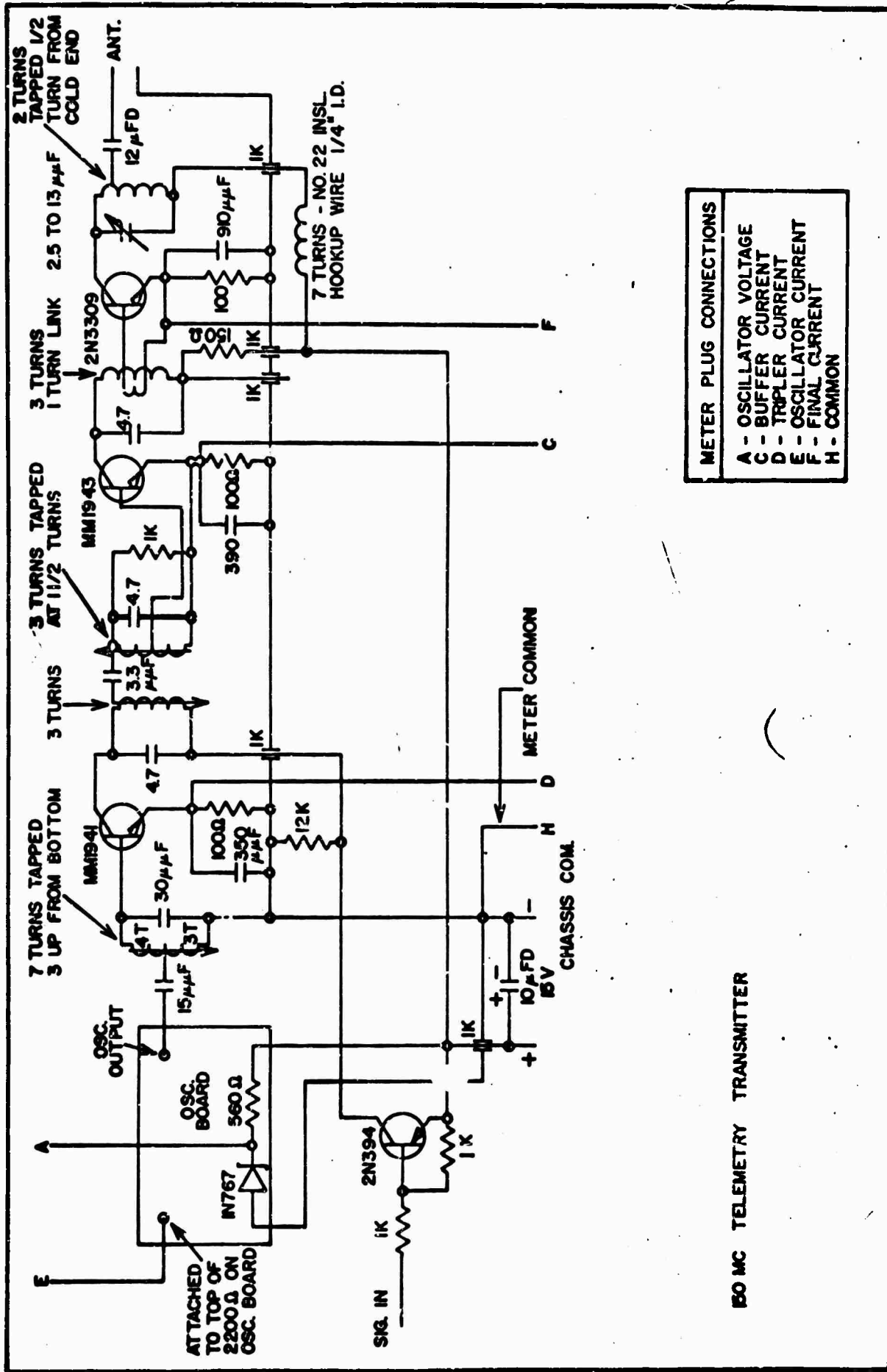
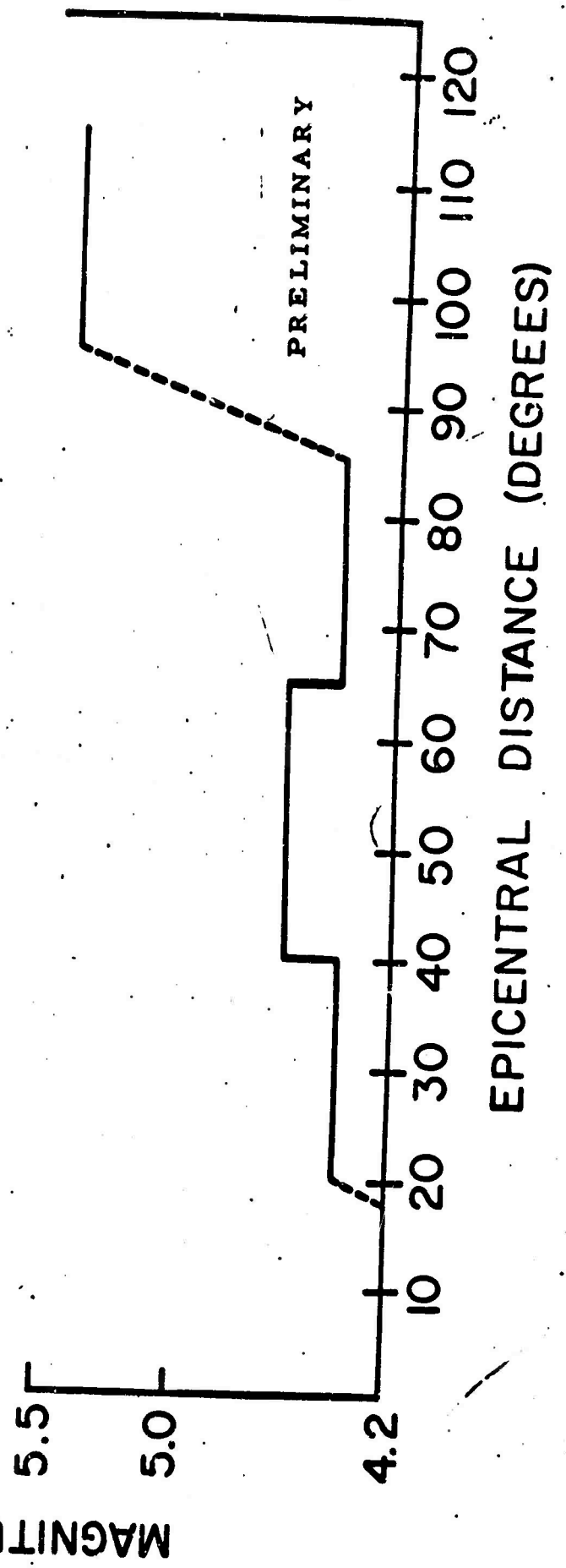
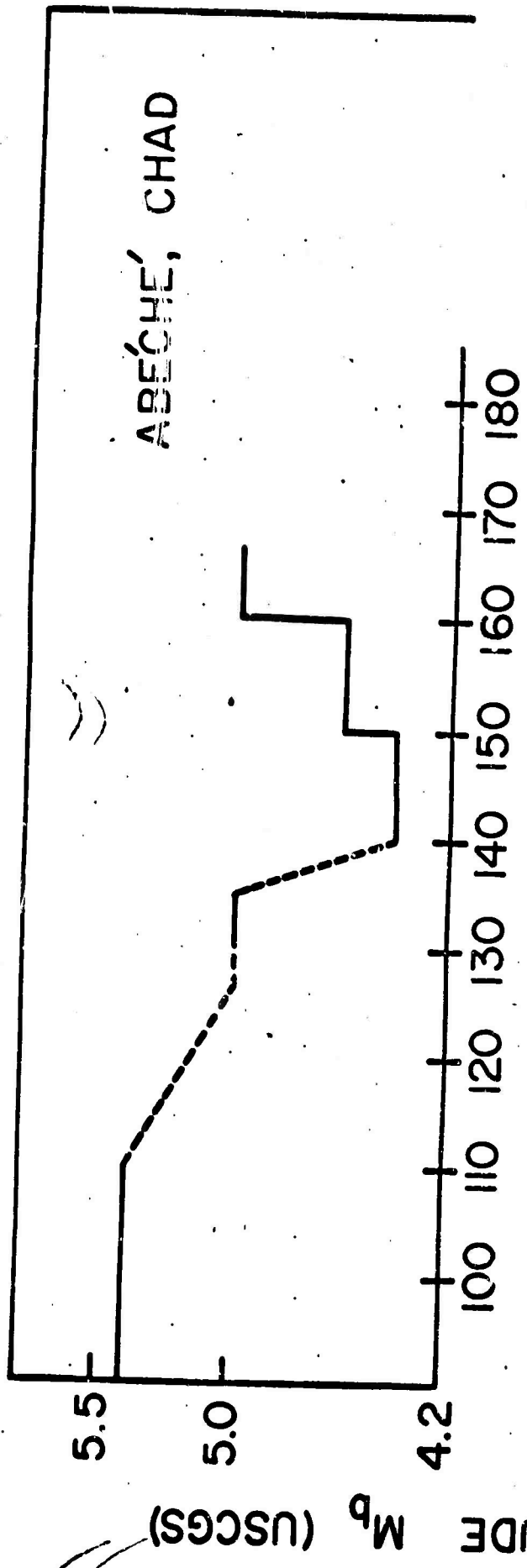

Figure 24. A view of the old west satellite station.



METER PLUG CONNECTIONS	
A	OSCILLATOR VOLTAGE
C	BUFFER CURRENT
D	TRIPPLER CURRENT
E	OSCILLATOR CURRENT
F	FINAL CURRENT
H	COMMON

150 MC TELEMETRY TRANSMITTER



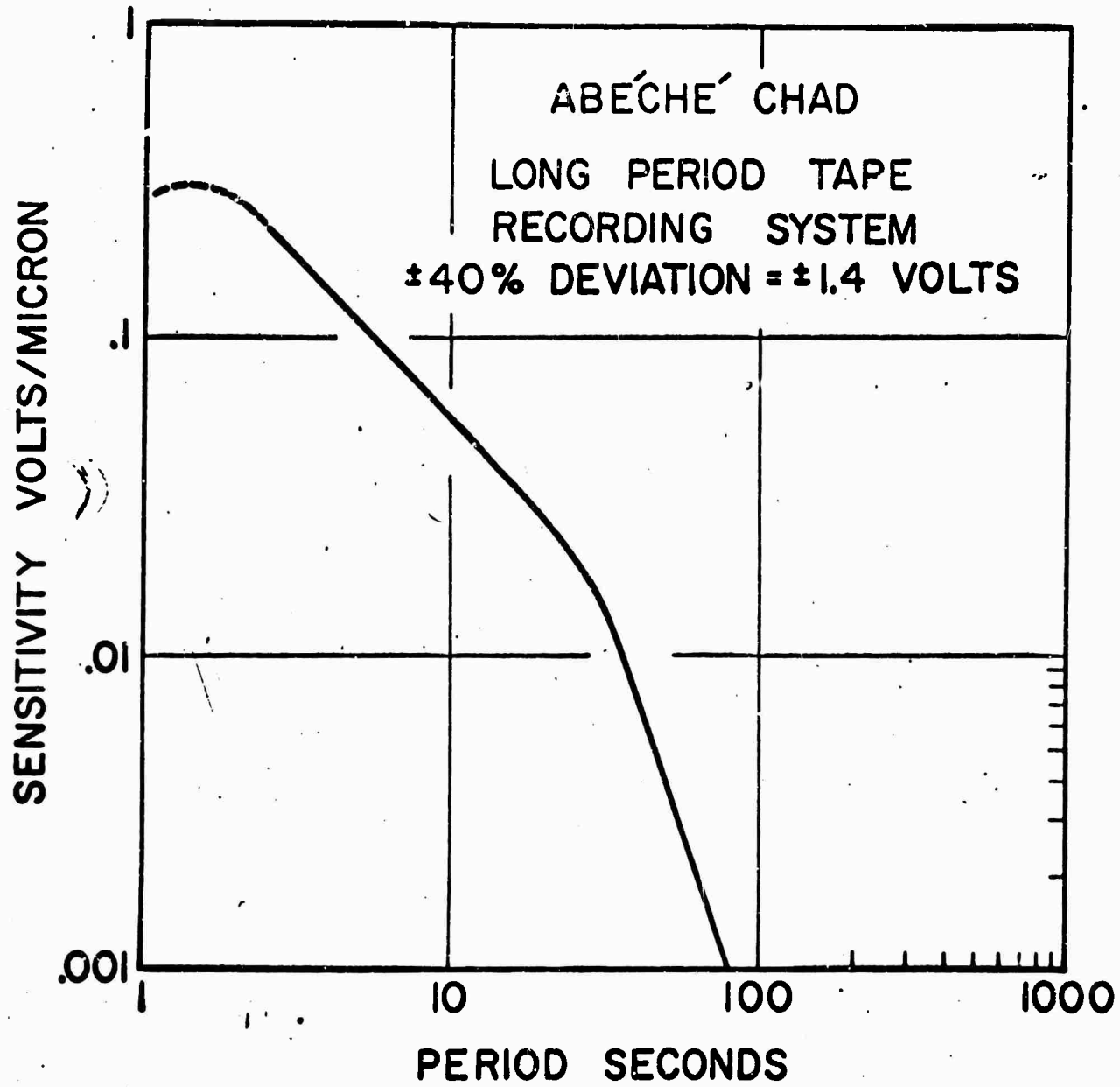

## DOCUMENT CONTROL DATA - R&amp;D

(Security classification of title, body of abstract and indexing annotation must be entered when the overall report is classified)

1 ORIGINATING ACTIVITY (Corporate author) Lamont Geological Observatory Columbia University Palisades, New York 10964		2a REPORT SECURITY CLASSIFICATION Unclassified	
		2b GROUP	
3 REPORT TITLE TWO SEISMOGRAPH STATIONS ON THE AFRICAN CONTINENT			
4 DESCRIPTIVE NOTES (Type of report and inclusive dates) Final Report 1 April 1964 - 31 March 1966			
5 AUTHOR(S) (Last name, first name, initial) Pomeroy, Paul W.			
6. REPORT DATE	7a. TOTAL NO. OF PAGES 22	7b. NO. OF REFS	
8a. CONTRACT OR GRANT NO. AF-AFOSR 678-64	8a. ORIGINATOR'S REPORT NUMBER(S) --		
b. PROJECT NO. 8652			
c.	8b. OTHER REPORT NO(S) (Any other numbers that may be assigned this report)		
d.			
10. AVAILABILITY/LIMITATION NOTICES Qualified requesters may obtain copies of this report from DDC. Others may obtain copies of this report from the Office of Technical Services, Dept. of Commerce.			
11. SUPPLEMENTARY NOTES		12. SPONSORING MILITARY ACTIVITY Air Force Office of Scientific Research Office of Aerospace Research United States Air Force	
13. ABSTRACT Two seismograph stations have been established in Africa, one at Lamto, Ivory Coast, and one at Abéché, Chad. This report contains a detailed description of the instrumentation and preliminary results at the Abéché station. At Abéché, a 3 element 3-component short period array 15 kms on a side is operated. The seismograph signals at the end points of the array are telemetered to a central station where they are recorded photographically and on magnetic tape. Short period gains of approximately 300,000 are utilized. Preliminary results on the detection capability of this station as a function of magnitude and distance are presented.			

14. KEY WORDS	LINK A		LINK B		LINK C	
	ROLE	WT	ROLE	WT	ROLE	WT
Abéché, Chad high gain, short period seismographs array telemetered seismic data						

**INSTRUCTIONS**

1. **ORIGINATING ACTIVITY:** Enter the name and address of the contractor, subcontractor, ... (corporate author) issuing the report.
- 2a. **REPORT SECURITY CLASSIFICATION:** Enter the overall security classification of the report. Indicate whether "Restricted Data" is included. Marking is to be in accordance with appropriate security regulations.
- 2b. **GROUP:** Automatic downgrading is specified in DoD Directive 5200.10 and Armed Forces Industrial Manual. Enter the group number. Also, when applicable, show that optional markings have been used for Group 3 and Group 4 as authorized.
3. **REPORT TITLE:** Enter the complete report title in all capital letters. Titles in all cases should be unclassified. If a meaningful title cannot be selected without classification, show title classification in all capitals in parenthesis immediately following the title.
4. **DESCRIPTIVE NOTES:** If appropriate, enter the type of report, e.g., interim, progress, summary, annual, or final. Give the inclusive dates when a specific reporting period is covered.
5. **AUTHOR(S):** Enter the name(s) of author(s) as shown on or in the report. Enter last name, first name, middle initial. If military, show rank and branch of service. The name of the principal author is an absolute minimum requirement.
6. **REPORT DATE:** Enter the date of the report as day, month, year, or month, year. If more than one date appears on the report, use date of publication.
- 7a. **TOTAL NUMBER OF PAGES:** The total page count should follow normal pagination procedures, i.e., enter the number of pages containing information.
- 7b. **NUMBER OF REFERENCES:** Enter the total number of references cited in the report.
- 8a. **CONTRACT OR GRANT NUMBER:** If appropriate, enter the applicable number of the contract or grant under which the report was written.
- 8b, 8c, & 8d. **PROJECT NUMBER:** Enter the appropriate military department identification, such as project number, subproject number, system numbers, task number, etc.
- 9a. **ORIGINATOR'S REPORT NUMBER(S):** Enter the official report number by which the document will be identified and controlled by the originating activity. This number must be unique to this report.
- 9b. **OTHER REPORT NUMBER(S):** If the report has been assigned any other report numbers (either by the originator or by the sponsor), also enter this number(s).
10. **AVAILABILITY/LIMITATION NOTICES:** Enter any limitations on further dissemination of the report, other than those

imposed by security classification, using standard statements such as:

- (1) "Qualified requesters may obtain copies of this report from DDC."
- (2) "Foreign announcement and dissemination of this report by DDC is not authorized."
- (3) "U. S. Government agencies may obtain copies of this report directly from DDC. Other qualified DDC users shall request through \_\_\_\_\_."
- (4) "U. S. military agencies may obtain copies of this report directly from DDC. Other qualified users shall request through \_\_\_\_\_."
- (5) "All distribution of this report is controlled. Qualified DDC users shall request through \_\_\_\_\_."

If the report has been furnished to the Office of Technical Services, Department of Commerce for sale to the public, indicate this fact and enter the price, if known.

11. **SUPPLEMENTARY NOTES:** Use for additional explanatory notes.
12. **SPONSORING MILITARY ACTIVITY:** Enter the name of the departmental project office or laboratory sponsoring (paying for) the research and development. Include address.
13. **ABSTRACT:** Enter an abstract giving a brief and factual summary of the document indicative of the report, even though it may also appear elsewhere in the body of the technical report. If additional space is required, a continuation sheet shall be attached.

It is highly desirable that the abstract of classified reports be unclassified. Each paragraph of the abstract shall end with an indication of the military security classification of the information in the paragraph, represented as (TS), (S), (C), or (U).

There is no limitation on the length of the abstract. However, the suggested length is from 150 to 225 words.

14. **KEY WORDS:** Key words are technically meaningful terms or short phrases that characterize a report and may be used as index entries for cataloging the report. Key words must be selected so that no security classification is required. Identifiers, such as equipment model designation, trade name, military project code name, geographic location, may be used as key words but will be followed by an indication of technical context. The assignment of links, rules, and weights is optional.