



AD 653785

AD

TECHNICAL REPORT ECOM - 02304-3
HIGH ENERGY SYSTEM (ORGANIC ELECTROLYTE)

THIRD QUARTERLY REPORT

By
H. R. Buhner, V. J. Spera

REC'D
RECEIVED
JUN 27 1967
B

JUNE, 1967

.....
ECOM

UNITED STATES ARMY ELECTRONICS COMMAND • FORT MONMOUTH, N.J.

CONTRACT DA-28-043-AMC-02304(E)
THE ELECTRIC STORAGE BATTERY COMPANY
THE CARL F. NORBERG RESEARCH CENTER
YARDLEY, PENNSYLVANIA

Distribution of this Document is Unlimited

ARCHIVE COPY

54

TECHNICAL REPORT ECOM-02304-3

APRIL 1967

HIGH ENERGY SYSTEM (ORGANIC ELECTROLYTE)

THIRD QUARTERLY REPORT

15 December 1966 To 15 March 1967

Report No. 7

CONTRACT NO. DA-28-043-AMC-02304(E)

Prepared By

H. R. Buhner, V. J. Spera

THE ELECTRIC STORAGE BATTERY COMPANY
THE CARL F. NORBERG RESEARCH CENTER
YARDLEY, PENNSYLVANIA

for

ELECTRONIC COMPONENTS LABORATORY

U. S. ARMY ELECTRONICS COMMAND, FORT MONMOUTH, N. J.

Distribution of this Document is Unlimited

ACCESSION for	
CFSTI	WHITE SECTION <input checked="" type="checkbox"/>
DDC	BUFF SECTION <input type="checkbox"/>
UNANNOUNCED	<input type="checkbox"/>
CLASSIFICATION	
BY	
DISTRIBUTION/AVAILABILITY CODES	
DIST.	AVAIL. and/or SPECIAL
1	

NOTICES

Disclaimers

The findings in this report are not to be construed as an official Department of the Army position, unless so designated by other authorized documents.

The citation of trade names and names of manufacturers in this report is not to be construed as official Government indorsement or approval of commercial products or services referenced herein.

Disposition

Destroy this report when it is no longer needed. Do not return it to the originator.

ABSTRACT

This report includes the results of investigations on the Li/CuF₂ system during the third quarter of Contract No. DA-28-043-AMC-02304(E), "High Energy System - Organic Electrolyte."

In a continuing search for new organic electrolytes, tetramethylurea and 1,2-propylene glycol sulfite were investigated as electrolyte solvents and the organic sulfur compound was found to be promising. A re-evaluation of the effect of electrolyte concentration on CuF₂ solubility revealed that solubility increased as electrolyte concentration increased over the range 2.5×10^{-3} to 1.0 F LiClO₄/propylene carbonate.

The solubility of CuF₂ in electrolyte was studied as a function of time and it was found that the concentration increased with time over a period of 25 days.

Various purification treatments were applied to LiClO₄ and the effect of solutions of these salts in propylene carbonate on the CuF₂ solubility was determined. The lowest solubility was found in solutions containing LiClO₄ recrystallized from water and made anhydrous, but the results were somewhat inconsistent and indicate a need for further investigation.

Southwestern 1051 graphite was purified by various methods and it was found that the activated storage of CuF₂ cathodes thereby improved. The improvement was also reflected in the activated stand of Li/CuF₂ cells.

Complexones were re-evaluated and ethylene diamine at a level of 0.05% in 1F LiClO₄/propylene carbonate was found to improve activated storage of Li/CuF₂ cells. However, the effect was only marginal.

Kinetic studies of CuF₂ cathodes appear to show that the reaction is diffusion limited in LiClO₄/propylene carbonate electrolytes.

A study of voltammetry in a mercury pool cell was initiated to determine the copper species in electrolyte containing dissolved CuF₂. Preliminary investigations and cell design are in progress and experimental results should be available in the fourth quarter.

LIST OF FIGURES

1. Specific Conductance of Electrolytes
2. Corrosion of Lithium in Electrolytes
3. Rate of Solubility of CuF_2 in Electrolyte
- 4-7 Effect of Activated Stand on Cathode Performance
8. Effect of Graphite Purification on Activated Cell Stand Performance
9. Effect of Ethylene Diamine Complexone on CuF_2 Cathode Performance
10. Effect of Diethylene Triamine Complexone on CuF_2 Cathode Performance
11. Effect of Complexones on Activated Storage of Li/CuF_2 Cells
12. Performance of CuF_2 Cathodes in $\text{LiClO}_4/1, 2$ propylene glycol sulfite electrolyte
- 13-15 Chronopotentiograms of CuF_2 Cathode Discharge
16. Potential-Time Transient
- 17-19 Potential-Current Relationship of CuF_2 Cathode Discharge
20. Mercury Pool Cell

LIST OF TABLES

1. Spectrographic analysis of CuF_2
2. Solubility of CuF_2 in LiClO_4 /propylene carbonate solutions
3. Spectrographic analysis of LiClO_4
4. Solubility of CuF_2 in various electrolytes
5. Spectrographic analysis of purified graphite
6. Effect of electrolyte concentration and current density

on $\frac{i/\tau}{c}$

TABLE OF CONTENTS

Abstract	i
List of Tables	ii
List of Figures	iii
Introduction	1
1. Electrolyte Studies	1
1.1 Investigation of Organic Solvents	1
1.2 Determination of Conductance	2
1.3 Lithium Corrosion Study	2
1.4 Determination of CuF_2 Solubility in LiClO_4 / Propylene Carbonate	3
1.4.1 Effect of Electrolyte Concentration on CuF_2 Solubility	3
1.4.1.1 Preparation of Solutions	3
1.4.1.2 Analysis of Solutions	3
1.4.2 Rate of Solubility of CuF_2 in LiClO_4 / Propylene Carbonate	4
1.4.2.1 Experimental Procedure	4
1.4.2.2 Analysis of Solutions	4
1.5 Effect of LiClO_4 Purification Technique on CuF_2 Solubility	5
1.5.1 Purification and Drying Techniques	5
1.5.2 Spectrographic Analysis of Purified LiClO_4	5
1.5.3 Analysis of CuF_2 Solubility in Various Electrolytes	5

TABLE OF CONTENTS (Cont'd)

2.	Cathode Studies	6
2.1	Purification of Graphite	6
2.1.1	Purification of Graphite by Various Methods ...	7
2.1.2	Spectrographic Analysis of Graphite	8
2.1.3	Effect of Graphite Purification on CuF_2 Cathode Activated Storage	8
2.1.4	Effect of Graphite Purification on Li/CuF_2 Cell Activated Storage	9
2.2	Effect of Complexones on CuF_2 Cathode Performance ..	10
2.2.1	Experimental Procedure	10
2.2.2	Effect of Complexones on Activated Storage of Li/CuF_2 Cells	11
2.3	Performance of CuF_2 Cathodes in $\text{LiClO}_4/1, 2$ Propylene Glycol Sulfite	11
2.3.1	Experimental Procedure	12
3.	Kinetic Studies of CuF_2 Cathodes	12
3.1	Voltammetry at Constant Current	12
3.1.1	Experimental Approach	12
3.2	Current Sweep Voltammetry	13
3.2.1	Experimental Approach	13
4.	Voltammetry in Quiet Mercury Pool	15
	List of Materials and Supplies	16
	References	17

INTRODUCTION

This report describes the work performed during the third quarter of Contract DA-28-043-AMC-02304(E), High Energy System (Organic Electrolyte). The goal of this work is to improve the activated storage life, and to increase the current density capability of the Li/CuF₂ cells.

A continuing search was made for new electrolyte solvents in order to obtain an electrolyte with properties superior to those of LiClO₄/propylene carbonate solutions. Tetramethylurea and 1,2-propylene glycol sulfite were investigated, and the organic sulfur compound was found to be promising.

Methods for purifying graphite were investigated as a result of the observations that certain impurities were adversely affecting cathode performance on activated stand.

Complexones were re-evaluated, and although it was found that ethylene diamine effected an improved activated stand for Li/CuF₂ cells, the improvement was only marginal.

Studies of CuF₂ cathode discharge kinetics were continued and, it appears from the results obtained using chronopotentiometric techniques that the reaction is diffusion controlled in LiClO₄/propylene carbonate solutions.

EXPERIMENTAL

1. Electrolyte Studies

This work was done in a continuing effort to obtain an electrolyte superior to LiClO₄/propylene carbonate with regard to viscosity and conductivity characteristics. It has been indicated previously that the somewhat high viscosity of the LiClO₄/propylene carbonate system appears to prevent high rate discharge of the CuF₂ cathode. The adverse effect of viscosity on mass transport causes the cathode reaction to be diffusion limited. This may be aggravated by the formation of a film of LiF on the active sites which further retards ion diffusion. Mass transport should be improved with an electrolyte of low viscosity and thereby should alleviate diffusion limitation problems.

1.1 Investigation of New Organic Solvents

Electrolyte investigations were concerned with the evaluation of two new organic solvents during the third quarter. Certain metals have been electrodeposited from solutions of inorganic salts in tetramethylurea (1), including Zinc, Bismuth, Silver, and Cadmium. No work with lithium was included in this study, but since it was shown that the solvent is capable of dissolving many inorganic salts it was considered worthy of investigation.

Recent investigations of organic sulfur derivatives as electrolyte solvents (2) have shown that propylene glycol sulfite is a promising material. Solutions of LiClO_4 in this solvent were reported to have the best electrochemical characteristics of the many systems studied. This solvent was selected for our investigations to determine its characteristics and compatibility with the Li/CuF_2 couple.

The physical characteristics of these solvents are as follows:

Solvent	Dielectric Constant	B. P. ($^{\circ}\text{C}$)	M. P. ($^{\circ}\text{C}$)	Viscosity (cp)	Density
Tetramethylurea	23.5	170	--	1.38	0.972
Propylene Glycol	33	240	-70	1.76	1.296

Sulfite

1.2 Determination of Conductance of New Electrolytes

In evaluating the solvents selected for study, only LiClO_4 was used as a solute. The solvents were the purest commercially available and were used as received. The LiClO_4 was the purified material described previously (3). Solutions were prepared over a wide concentration range, and all procedures conducted in a dry, argon atmosphere.

The conductance of the electrolytes was determined using a Kraus and Bray type cell in conjunction with a 1000 cycle A. C. Bridge (E. S. I. Universal Impedance Bridge, Model 290 R).

The results of this experiment are shown in Figure 1. The maximum specific conductance was about $7 \times 10^{-3} \text{ ohm}^{-1} \text{ cm}^{-1}$ for 0.65 F LiClO_4 /tetramethylurea and $4.5 \times 10^{-3} \text{ ohm}^{-1} \text{ cm}^{-1}$ for 1.0 F LiClO_4 /1,2-propylene glycol sulfite.

1.3 Lithium Corrosion Study

The compatibility of lithium with organic electrolytes is an important factor in the selection of an electrolyte for applications where there is a requirement for long periods of activated storage. The criterion of compatibility was taken as the rate of corrosion of lithium as determined by the micro-gassing technique (4). The time required for one milliliter of gas to be evolved was used as a relative measure of the rate of corrosion.

The results of this experiment are shown in Figure 2. The corrosion rate was lower in the propylene glycol sulfite solution than in the tetramethylurea

solution. The results with propylene glycol sulfite were comparable to those obtained with propylene carbonate as the solvent. The rate of corrosion in the tetramethylurea solution was too high for further consideration of this solvent.

Further investigation of propylene glycol sulfite was conducted, to determine CuF_2 cathode performance in electrolyte using this solvent. This is described in section 2.3 of this report.

1.4 Determination of Cupric Fluoride Solubility in LiClO_4 /Propylene Carbonate Solutions

1.4.1 Effect of Electrolyte Concentration on Cupric Fluoride Solubility

This study was conducted to determine the effect of electrolyte concentration on CuF_2 solubility. An earlier experiment (3) was carried out in an electrolyte containing LiClO_4 which had been purified by recrystallization twice from water and then once from anhydrous ether, and dried under heat and vacuum. In this test the solutions were centrifuged in an argon atmosphere to remove the suspended CuF_2 and a slight temperature increase was found which could have caused the solubility to increase. In the present experiment the solutions were filtered with no centrifuging, to prevent this problem.

1.4.1.1 Preparation of Solutions

Solutions of purified, anhydrous LiClO_4 (water and ether recrystallized) in twice distilled propylene carbonate were made over the concentration range: 2.5×10^{-3} F to 1.0 F.

Cupric fluoride powder (as received) was heated at 60°C for 17 hours under vacuum to remove unreacted HF. A spectrographic analysis of the CuF_2 (Ozark-Mahoning, Lot No. R5-131) used in the experiment is shown in Table 1. It can be seen that the materials are of similar purity; a comparison is made to a previous lot (KW 4-17).

A weight of 150 mg of the CuF_2 was added to 50 ml of each of the electrolyte solutions. The solutions were prepared in a dry argon atmosphere and stored under argon for two weeks. The flasks were shaken daily during this period. The suspensions were then filtered under argon through highly retentive filter paper to separate any suspended CuF_2 . They were then submitted for analysis to determine the copper concentration.

1.4.1.2 Analysis of Solutions

The solutions were analyzed photometrically, using neocuproine indicator, by the method described in the First Quarterly Report. The results of the experiment are shown in Table 2. An increase in LiClO_4 concentration caused

a slight increase in copper solubility. This is in agreement with the results in the Second Quarterly Report. The lower solubility in the latest experiment might be due to the electrolyte being extremely pure and the solutions being filtered and not centrifuged.

The impurities in the CuF_2 may be responsible for the copper solubility, especially iron which is present in 1000 ppm. To reduce the solubility it may be necessary to develop a method for purification of the CuF_2 .

1.4.2 Rate of Solubility of Cupric Fluoride in Electrolyte

This experiment was conducted to determine the rate of solubility of CuF_2 with time in 1F. LiClO_4 /propylene carbonate electrolyte. It was thought that the results would give some indication whether the solubility was simply that of a sparingly soluble salt or due to a reaction between the electrolyte. It was assumed that a simple solubility mechanism would be shown by a solubility-time function, leading to a constant copper concentration as the solution became saturated.

1.4.2.1 Experimental Procedure

The electrolyte used in this experiment was 1F. LiClO_4 in doubly distilled propylene carbonate. The LiClO_4 was purified by recrystallization from twice distilled water and then from anhydrous diethyl ether. The anhydrous cupric fluoride (Lot # KW4-17) was heated at 60° for 17 hours under vacuum to remove any unreacted HF. A one liter gas washing bottle with a fritted glass inlet tube and a gas outlet tube was used. Cupric fluoride powder and 400 ml. of electrolyte were added to the flask. A continuous stream of high purity dry argon (99.995%) was passed through drierite and concentrated sulfuric acid and then bubbled through the test solution in order to provide an inert atmosphere and to agitate the mixture. The exhaust argon was bubbled through a flask containing purified propylene carbonate to act as a gas lock. Temperature was maintained at 25° by immersion of the apparatus in a thermostated water bath. Samples of solution were removed from the flask at various intervals and filtered under a dry argon atmosphere.

1.4.2.2 Analyses of Solutions

The solutions were analyzed photometrically using the technique described in section 1.4.1.2. The results of this experiment are shown in Figure 3. The solubility of CuF_2 was found to increase with time in a somewhat unexpected relationship, i.e., the rate of solubility increased with an increase in time. The solubility increased from 5.4 mg. Cu ion/liter after one day to 116 mg. Cu ion/liter after 25 days.

It would appear from these results that the solubility mechanism is not simple, i. e. as would be shown by a gradually decreasing rate of solubility with time until a stable concentration was obtained at saturation. The results would indicate that a reaction between CuF_2 and electrolyte occurs which accelerates the rate of CuF_2 solubility. However, there might be another explanation for this behavior which involves the experimental technique used. The volume of solution was steadily depleted as samples were taken for analysis over the test period. If it is assumed that the rate of solubility is due to a reaction between the CuF_2 and the electrolyte then it will also depend on the volume of electrolyte in contact with a given amount of CuF_2 at any time, and the rate of solubility might be found to increase as the volume is decreased. This appears to be a reasonable explanation for the behavior observed and indicates that the experimental technique requires modification. Therefore the test will be repeated using invariant volumes of solution and with other refinements intended to effect more reliable results.

1.5 Effect of LiClO_4 Purification Technique on CuF_2 Solubility

The activated storage life of Li/CuF_2 cells might be improved if the solubility of CuF_2 could be greatly reduced. It is thought that part of the solubility problem is associated with certain impurities in the LiClO_4 used in preparation of electrolyte. Therefore, LiClO_4 was purified according to various techniques and the effect on CuF_2 solubility determined in electrolytes prepared with the various salts.

1.5.1 Experimental Procedure

The technique used in the preparation of purified LiClO_4 was described in a previous report (3). Methods involving recrystallization from water and ether were described. These methods, in whole or in part were used in the preparation of various LiClO_4 salts in this experiment. Also included as control was LiClO_4 salt which was used as received from the supplies. The respective treatments were as follows: (i) control (no purification), (ii) recrystallized once from ether, (iii) recrystallized twice from water and once from ether and (iv) recrystallized twice from water.

1.5.2 Spectrographic Analysis

The LiClO_4 , as received and purified by the various techniques, was analyzed spectrographically and the results are shown in Table 3. In general, very little removal of metallic impurities was effected with any of the treatments. The most effective treatment relatively was ether recrystallization alone.

1.5.3 Determination of CuF_2 Solubility in Various Electrolytes

Electrolyte solutions containing 1 formal LiClO_4 in distilled propylene carbonate were prepared using the salts treated according to the method described above.

In addition, 1% (by volume) water was added to one electrolyte to determine its effect on CuF_2 solubility. The solubility tests were conducted using the basic techniques described in section 1.4.1.1 of this report. The test was run once with no replication.

The result of this experiment are shown in Table 4. The solubility of CuF_2 ranged from 10 to 46 mg. Cu ion per liter in the various anhydrous solutions. The effect of the addition of only 1% water was to increase CuF_2 solubility by one to two orders of magnitude as compared with results in anhydrous solutions. It appears that the lowest solubility was effected with LiClO_4 recrystallized from water alone. The higher solubility in solutions prepared with LiClO_4 treated with ether would indicate that ether somehow introduces a solubilizing effect. However, according to the spectrographic analyses, ether recrystallization appeared to effect the best purification, at least as far as removal of metallic impurities is concerned: It is difficult to draw conclusions from these somewhat inconsistent results. This is probably due to the aforementioned effect of increasing solubility with time. The samples were not all equilibrated for the same time and thus the results can only be regarded as preliminary.

2. Cathode Studies

2.1 Purification of Graphite (SW1651 micronized)

Earlier studies of cathode activated stand (3) revealed a loss in performance of CuF_2 electrodes after storage in electrolyte. Associated with this was the formation of LiF in the electrode as determined by x-ray diffraction. This behavior was attributed to certain impurities in the SW1651 graphite used in the electrode construction. When high purity graphite (spectrographic grade) was used, LiF was not detected after stand. These observations indicated that degradation of the cathode salt occurred, by direct reaction with, or catalysis by the graphite impurities.

The performance of Li/CuF_2 cells after activated storage has been shown to be unsatisfactory. This has been associated with solubility of the CuF_2 and consequent short-circuiting of the cells by copper dendrites. Cupric fluoride is of course soluble to some extent in the electrolyte, but it was thought that possibly certain impurities in the graphite used in the cathodes might increase the solubility and further aggravate the loss of cell efficiency on activated stand.

In a preliminary experiment, cathodes were made without graphite to determine how this might affect copper dendrite formation in Li/CuF_2 cells. Cathodes were prepared from a blend of 91% CuF_2 (KW4-17) and 9% polyethylene (-100 mesh). Two grams of blend were die-pressed at 500 g/cm^2 for 3 minutes at 90°C . Three plate Li/CuF_2 cells were made using 30 mils of glass fiber filter paper insulation.

58

The cells were filled with 1F. LiClO₄/propylene carbonate (purified) and placed in a dry argon atmosphere. Cells were taken off stand after 3 days and after two weeks for inspection. No copper dendrite formation was observed in the separation after two weeks storage. A film of copper was deposited on the anodes but this appeared to be extremely thin. These results were a further indication that impurities in the graphite might be responsible for loss of cathode efficiency on activated stand. Therefore, a program of work was initiated to purify the SW1651 micronized graphite used in cathode fabrication and to determine the effect of this treatment on cathode activated storage.

2.1.1 Purification of SW1651 Graphite - Methods Used

The following methods were used to purify SW1651 micronized graphite.

i) Nitric Acid Treatment

Thirty grams of graphite was slurried with 600 ml. of nitric acid solution (1:1 concentrated HNO₃ and water). The mixture was maintained at 60°C for 17 hours, with continuous stirring during the period. The slurry was then filtered, and the product washed with distilled water. The graphite was dried under vacuum, at 120°C for 10 hours.

ii) Hydrochloric Acid Treatment

Thirty grams of impure graphite was leached in 600 ml. of HCl solution (1:1 concentrated HCl and distilled H₂O) at 70°C for 17 hours with continuous stirring. The product was washed thoroughly and dried at 130°C under vacuum.

iii) Nitric/Hydrochloric Acid Treatment

a) Thirty grams of impure graphite was leached in 600 ml. of hydrochloric acid (1:1 concentrated HCl and distilled water) at 80°C for 17 hours with continuous stirring. The product was filtered and washed with 1 liter of distilled water.

b) Step a) was repeated.

c) The graphite from step b) was leached in 600 ml. of nitric acid (1:1 HNO₃ and distilled H₂O) at 70°C for 17 hours. The product was filtered and washed with 1 liter of distilled water.

d) Repeat step c).

e) The product from step d) was washed thoroughly in a filter and dried at 120°C under vacuum for 10 hours.

2.1.2 Spectrographic Analyses of Graphite

Graphite purified according to the respective techniques described above was submitted for spectrographic analyses and the results are shown in Table 5.

The hydrochloric acid treatment was very effective in removing Fe, Ti, Cu and the nitric acid treatment in removing Mg and Mo. The highest purity graphite was obtained by a combined HCl/HNO₃ treatment.

2.1.3 Effect of Purified Graphite on CuF₂ Cathode Activated Storage

This study was conducted to determine the effect on cathode activated stand of the various graphite purification techniques.

Cupric fluoride cathode were made from blends of 85% CuF₂ (-325 mesh), 5% polyethylene (100 mesh) and 10% SW1651 graphite. Various blends were made incorporating respectively impure, HNO₃ treated, HCl treated, and HCl/HNO₃ treated graphites. Two grams of the respective blends were die-pressed into a 5Cu14-2/0 expanded copper grid (1½ x 15/8") at 3000 #/cm² for 3 minutes at 90°C.

Cathodes incorporating the various graphites were assembled into 3 plate cells against Li anodes and insulated with 30 mils of glass fiber filter paper. The cells were filled with 1F LiClO₄/propylene carbonate (purified) and discharged at 2 ma/cm² to determine their initial (no stand) performance. In addition, cathodes were stored alone (dissassociated from the Li anodes) in electrolyte for two weeks in a dry argon atmosphere. After stand, cathodes representing the various graphite treatments were submitted for x-ray analysis. Replicate electrodes (two weeks storage) were assembled into 3 plate cells against Li anodes, and discharged as above.

The results of the various experiments are shown in Figures 4 to 7. Inspection of these results reveals that the effect of graphite purification was to improve the cathode activated storage capability. With impure graphite a 43% loss in coulombic efficiency was obtained after two weeks, whereas only 28% loss was found with HNO₃ treated graphite, and practically no loss with HCl and HCl/HNO₃ treatments. However, there was a decrease in cathode discharge potentials associated with purified graphite. This was not evident with electrodes containing impure graphite, which although suffering a greater loss in coulombic efficiency, appeared to have discharge characteristics which were very similar before and after stand.

In those electrodes submitted for x-ray analysis (undischarged) after two weeks activated stand, LiF was found only in those containing unpurified graphite. No free copper was found in any of the electrodes. No compounds other than those originally present could be detected.

Apparently the purification of SW1651 graphite improves the activated storage capability of CuF_2 cathodes with regard to coulombic efficiency. However, there is a large decrease in discharge potentials after stand which is difficult to explain.

A reaction between CuF_2 and the electrolyte to produce a material discharging at lower potentials than CuF_2 , or a resistance change in the electrical structure on stand, might account for the behavior. However, further work remains to be done before any conclusive statements can be made. A study of I.R. Spectra of electrolyte solution containing CuF_2 might reveal the mechanisms responsible for the loss of cathode potential on activated storage.

2.1.4 Effect of Graphite Purification on Activated Storage of Li/ CuF_2 Cells

Cathode storage tests have shown that purification of SW1651 graphite improves the activated storage capability of the CuF_2 electrode, at least with regard to coulombic efficiency. It was decided therefore to evaluate the effect of graphite treatment on the activated stand performance of Li/ CuF_2 cells.

Cupric fluoride electrodes were made using blends containing respectively impure and HCl/ HNO_3 treated graphite. The blends contained the same ratio of components described in section 2.1.3 of this report. Cathodes were prepared as described in section 2.1.3 except that die-pressing was done at 500 μcm^2 . Three-plate Li/ CuF_2 cells were made using cathodes containing the respective graphites, and filled with LiClO_4 /propylene carbonate electrolyte. They were discharged at 2ma/ cm^2 to determine the initial (no stand) cathode performance. In addition, replicate cells representing the two types of graphite treatment were stored activated for 1 week in a dry argon atmosphere. After stand they were discharged as above.

The results of these experiments are shown in Figure 8.

The initial performance of cathodes containing impure graphite was far better than that obtained with electrodes containing HCl/ HNO_3 treated graphite; about 75% coulombic efficiency with impure as compared to 45% efficiency with treated graphite. Further, discharge potentials were for better with cathodes containing impure graphite. After stand for one week, only 1% coulombic efficiency was obtained for cathodes with impure graphite, whereas cathodes containing treated graphite lost little or no performance.

The unusually low potential characteristic obtained with cathodes containing HCl/HNO₃ treated graphite is difficult to explain. This type of behavior was observed in the cathode tests described in section 2.1.3, for cathodes containing graphite with the same treatment. Possibly something in the specific treatment adversely affects cathode potentials.

Further work is required in the area of cathode and cell activated stand studies. An important part of this work will involve a study to determine the factors involved in the loss of coulombic efficiency and cathode potentials.

2.2 Effect of Complexones on CuF₂ Cathode Performance and Activated Stand

It was shown in an earlier investigation (4) that the use of certain complexing agents in LiClO₄/propylene carbonate solution improved the activated storage capability of the Li/CuF₂ cell, but at the expense of greatly reduced cell efficiency. A concentration of complexing agent (about 1%) sufficient to prolong activated storage adversely affected cathode efficiency. Further work was done (3) with lower concentrations (0.15% max.) but cathode efficiency was still adversely affected.

Investigations during the third quarter have shown that the Southwestern 1651 graphite, as received, has considerable amounts of impurities which apparently have adversely affected cathode performance on activated storage. Possibly the impure graphite had adversely affected activated storage in previous tests with complexones, and in addition might have affected initial (no stand) performance by some kind of interaction with the complexone. It was decided therefore to re-evaluate the effect of complexones using cathodes prepared with purified graphite.

2.2.1 Experimental Procedure

Cupric fluoride cathodes were prepared using a blend of 85% anhydrous CuF₂ (-325 mesh), 10% Southwestern 1651 graphite (purified by HNO₃/HCl), and 5% polyethylene (-100 mesh). Two grams of blend were die-pressed into a 1½" x 1 5/8" expanded copper grid (5 Cu14-2/0 mesh) at 500 #/cm² for three minutes at 90°C. Three-plate Li/CuF₂ cells were made using two pressed lithium ribbon anodes and one cathode, and insulated with 30 mils of glass fiber filter paper.

Electrolytes were prepared with compositions as follows:

i) 1F. LiClO₄/propylene carbonate, with 0.01 and 0.10 volume % ethylene diamine and

ii) 1F. LiClO₄/propylene carbonate, with 0.01 and 0.05 volume % diethylene triamine. Replicates of two cells were used to test the respective

complexones at each of the concentration levels. In addition, replicates of two cells were used as a control (no complexone). The cells were discharged at 2 ma/cm², and cathode potentials were measured against Ag/AgCl reference electrodes using an electrometer.

The results of this experiment are shown in Figures 9 and 10. In general, an increase in complexone concentration produced a decrease in cathode discharge efficiency. It is interesting that the percent loss of performance, at least at the 0.05% concentration level for both complexones, was less than in the previous experiment (3). This might be due to the use of purified graphite but this cannot be stated conclusively.

2.2.2 Effect of Complexones on Activated Storage of Li/CuF₂ Cells

The loss of cathode performance (no stand) was considered to be low enough, at least at the 0.05% level of complexone, and especially with ethylene diamine, to justify work with activated storage.

Three-plate Li/CuF₂ cells were made as described above, with replicates of two cells used to test each type of complexone at the 0.05% level in 1F. LiClO₄/propylene carbonate. Also, replicates of two cells were used as control (no complexone). The cells were activated with the respective electrolytes and placed on storage for one week in an argon filled container over drying agent.

After the one week stand all cells were discharged at 2ma/cm². Cathode potentials were measured against Ag/AgCl reference electrodes.

The results of this experiment are shown in Figure 11. It can be seen that the performance of control cells and that of cells with diethylene triamine was poor, with only about 3% CuF₂ utilization and very high cathode polarization. The performance of cells with ethylene diamine was relatively good, with about 16% coulombic efficiency. Cathode potentials however showed polarization as compared with initial performance.

It appears that the beneficial effect of ethylene diamine complexone in improving activated storage of Li/CuF₂ cells is only minimal and would be of little practical value. Greater improvements are required, and this might be accomplished by investigating other complexones.

2.3 Performance of CuF₂ Cathodes in LiClO₄/1, 2 Propylene Glycol Sulfite Electrolyte

It was shown in sections 1.2 and 1.3 that solutions of LiClO₄/1, 2 propylene glycol sulfite had reasonably good conductivities and were compatible with

lithium. Therefore it was decided to evaluate this new electrolyte in CuF_2 cathode tests.

2.3.1 Experimental Procedure

An electrolyte was prepared with composition 1.25F. LiClO_4 /propylene glycol sulfite. The solvent was used as received and the LiClO_4 was the purified material (3).

Three-plate Li/CuF_2 cells were made as described in section 2.2.1 of this report. Replicates of two cells were filled with the test electrolyte and discharged at $2 \text{ ma}/\text{cm}^2$. Cathode potentials were measured against Ag/AgCl reference electrodes in the same electrolyte.

The results of this experiment are shown in Figure 12. The coulombic efficiency of CuF_2 was about 60% (average) and reproducibility was good. Cathode discharge characteristics were similar to those obtained with LiClO_4 /propylene carbonate, except near the termination of discharge when potentials decreased more rapidly than in the propylene carbonate solutions.

The performance obtained with 1,2 propylene glycol sulfite shows promise and justifies further work. The logical approach in extended study would be purification of the solvent as a first step.

3. Kinetic Studies of the CuF_2 Cathode

Investigations of the kinetics of the CuF_2 discharge reaction were continued in an effort to elucidate the mechanism and to determine the rate limiting steps. Two techniques were employed involving a modified current sweep voltammetry and chronopotentiometry.

3.1 Chronopotentiometry

Cupric fluoride cathodes were tested in a glass three compartment cell of the type previously described (5). The cell was maintained at 25°C in a thermostatically controlled oil bath. Electrodes were discharged at various current densities in electrolytes of 0.25F, 0.5F and 1.0F LiClO_4 /propylene carbonate. The electrolyte was not stirred in order to obtain conditions of semi-infinite linear diffusion. Current was supplied by a 300 volt constant current power source. Cathode potentials were measured against Ag/AgCl reference electrodes in the same electrolyte.

The cathodes were prepared from a blend containing 85% anhydrous CuF_2 (-325 mesh), 10% graphite (SW1651) and 5% polyethylene (-100 mesh). Approximately 0.9 grams

of blend were diepressed at $3000\#/cm^2$ for 3 minutes, at $90^\circ C$, into a 1" square expanded copper grid.

The results of this experiment are shown in Figures 13, 14 and 15. From these results it can be seen that the discharge characteristics are considerably different in 0.25F and 0.50F as compared with 1.0F electrolyte. The curves in the 1F. solution show a fairly well defined transition time whereas no transition time exists in the 0.25F and 0.50F solution. The product $i\tau_{\frac{1}{2}}$ was found to be approximately constant for the 1F solutions as shown in Table 6. Since no transition time was observed for the dilute solution it was decided to examine the relationship between the time at which the deposition of lithium occurs (as indicated by levelling off of the curves) and the current density and electrolyte concentration. The results are shown in Table 6 where for the 0.5 and 0.25F solutions τ is to be interpreted as the time at which lithium begins to deposit.

It can be seen that there is good constancy of the factor $i\tau_{\frac{1}{2}}/C$. This would appear to indicate that the potential/time curves obey the Sand equation (6) and that the reaction is diffusion controlled. However since the interpretation of the chronopotentiograms is difficult, especially in the 0.50 and 0.25F solutions the agreement may be fortuitous.

3.2 Current - Potential Curves

Another technique used to study cathode kinetics was a modified current sweep voltammetric method. The glass three compartment cell previously described was used in this work. Cathodes (CuF_2) were prepared as described in section 3.1 and were tested as follows:

A preset current was pulsed through the electrode using a 300 volt constant current power supply in conjunction with a time-delay switching system. The delay switch allowed the oscilloscope to trigger the trace before the current pulse was applied, thereby allowing the measurement of the open circuit potential. In this way the IR polarization could be determined at the instant the current pulse was applied. Measurements were obtained using a Tetronix type 535 Oscilloscope in conjunction with a camera attachment to record the potential transients. Polaroid film was used with designation B and W 3000 speed/type 107.

The test was conducted over a range of current densities in $LiClO_4$ propylene carbonate of various concentrations. The electrolyte was stirred by vigorous bubbling of dry argon through the solution. Cathode potentials were measured against a $Ag/AgCl$ reference electrode.

A typical Potential-Time transient is shown in Figure 16. This trace was obtained at 5 ma/cm² in 1.0F LiClO₄/propylene carbonate electrolyte. The time-delay switch allows a recording of the open circuit potential for a few milliseconds before the pulse is applied. This allows the measurement of the IR component of polarization at the instant the current is applied, as shown by the break in the Potential-Time trace. Thereafter polarization increases and includes components of activation and diffusion overpotential. The transient becomes linear after an initial curved portion, and this is indication of diffusion control. The activation polarization is determined by extrapolating the linear portion of the trace (dashed line) back to an intersection with the vertical dashed line (time at instant current is applied). The activation polarization is then obtained by subtracting the IR component from the total polarization (ΔMV from O.C.V. to intersection of dashed lines).

The results of this experiment are shown in Figures 17, 18, 19.

The linear current/potential relationship is unusual in that, according to the modern treatments of the kinetics of porous electrodes, a logarithmic plot should be obtained. (7,8) The linear current/potential behaviour can be explained if it is assumed that the polarization is a function of the electrolyte resistance in the pores of the electrode. For example the polarization characteristics of an irreversible electrode can be written as

$$i = i_0 \left[\exp\left(\frac{an\eta}{RT}\right) - \exp\left(-\frac{(1-a)n\eta}{RT}\right) \right]$$

where the symbols have their usual significance. If $\alpha = \frac{1}{2}$, as is often the case in practice, then

$$(1-\alpha) = \alpha$$

and

$$i = i_0 \left[\exp\left(\frac{an\eta}{RT}\right) - \exp\left(-\frac{an\eta}{RT}\right) \right]$$

Using the Tafel terminology

$$\frac{RT}{an\eta} = b$$

therefore

$$i = i_0 \left[\exp\left(\frac{\eta}{b}\right) - \exp\left(-\frac{\eta}{b}\right) \right]$$

Since

$$\sinh\left(\frac{\eta}{b}\right) = \frac{1}{2} \left[\exp\left(\frac{\eta}{b}\right) - \exp\left(-\frac{\eta}{b}\right) \right]$$

the expression for the current potential can be written

$$i = 2i_0 \sinh\left(\frac{\eta}{b}\right)$$

The distribution of the potential is given by the Poisson equation

$$\frac{\partial^2 \eta}{\partial x^2} = S\rho = 2S_1\rho \sinh\left(\frac{\eta}{b}\right)$$

Integrating using the boundary conditions

$$\eta_x = 0 \text{ at } x = 0$$

$$\text{and } \eta = 0 \text{ at } x = b$$

gives

$$\eta = 2 \left(\frac{2S_1 b}{e} \right)^{\frac{1}{2}} \sinh \frac{\eta}{2b}$$

When $\eta < 2b$, $\eta \approx \frac{2S_1 b}{e} \frac{\eta}{2b}$ and the potential is a linear function of the current density.

When $\eta > 2b$, $\eta \approx \frac{2S_1 b}{e} \frac{\eta}{2b}$ and the potential should be a logarithmic function

of the current with a slope equal to twice the normal Tafel value. This one would expect a linear current/potential plot up to polarizations of about 240 mV.

It can be seen from the data that the curves are in fact linear up to about 250mV where they develop a curvature. In order to investigate whether a logarithmic relationship is obtained at high polarization higher current densities would have to be used.

4. Voltammetry in a Quiet Mercury Pool

This study has recently been initiated to determine the ionic copper species present in electrolyte solution containing dissolved CuF_2 . The technique makes use of a specially designed cell incorporating a mercury pool of large surface area. This is theoretically a more powerful analytical technique than the normal polarographic method where very low concentration of reducible species are present. Much information about this method can be found in the literature. (9-14)

A mercury pool cell was designed and built, with construction as shown in Figure 20. Preliminary tests with this cell revealed a very high resistance (11,000 OHMS) in the salt bridge. The polarographic apparatus was not capable of handling this impedance, and as a result the current-potential curves were poorly defined. Therefore a new cell is being designed to reduce the resistance factor to a minimum. This cell should be available during the fourth quarter.

List of Materials and Supplies

Cupric fluoride, anhydrous, 99.5% min.	Ozark-Mahoning Co.
Zinc fluoride, anhydrous, 99% min.	"
Potassium hexafluorophosphate, 98% min.	"
Propylene carbonate, 99% min.	Jefferson Chemical Co., Inc.
Lithium perchlorate	G. Frederick Smith Co.
Tetramethylurea	K and K Laboratories, Inc.
1, 2, -propylene glycol sulfite	"
Ethylene diamine, Fisher Reagent	Fisher Scientific Co.
Diethylene triamine	"
Lithium metal ribbon, 99.98%	Foot Mineral Co.

REFERENCES

- (1) Electrode Position of Metals from Tetramethylurea, R.G. Billingham, J. Raiki, and K.G. Rutherford, J. Appl. Chem., 1966, Vol. 16, 339
- (2) Electrolyte Solvent Properties of Organic Sulfur Derivatives, Richard E. Johnson, N.A.S.A. T.M. X-1283, Aug. 1966.
- (3) Buhner, H.R., Spera, V.J., Second Quarterly Report, Contract No. Da-28-043-AMC-02304(E)
- (4) Boden, D.P., Buhner, H.R., Spera, V.J., First Quarterly Report, Contract No. Da-28-043-AMC-03194(E)
- (5) Boden, D.P., Buhner, H.R., Spera, V.J., First Quarterly Report, Contract No. Da-28-043-AMC-02304(E)
- (6) H.J.S. Sand, Phil. Mag., 1, 45 (1901)
- (7) Lerner, H., Ph.D. Thesis, Pennsylvania State University, 1964
- (8) Austin, L.G., Report No. 3, Contract DA-49-186-502-ORD-917 Diamond Ordnance Fuze Laboratories, Pennsylvania State University, 1962.
- (9) Farsang, G.J., Electroanal. Chem., 13, 1967, 73-78
- (10) Streuli, C., Cooke, W., Anal. Chem., 26, 1954, 963-970
- (11) Streuli, C., Cooke, W., Anal. Chem., 25, 1953, 1691-1696
- (12) Rosi, D., Cooke, W., Anal. Chem., 27, 1955, 1360-1363
- (13) Coulter, P., Iwamoto, R.J., Electroanal. Chem., 13, 1967, 21-27
- (14) Meites, L., Polarographic Techniques, John Wiley and Sons, New York, 2nd Edition, 1965, 439-464.

TABLE 1

Impurities in As-received CuF₂ in Parts Per Million

	Lot No. KW 4-17	Lot No. R5-131
Si	500	1000
Mg	500	100
Tl	<10	<10
Ca	100	100
Al	100	100
Fe	1000	1000
Ag	100	10
Ni	1000	100
Mn	10	10
B	n. d.	1

n. d. - not detected

Table 2

Solubility of CuF₂ in LiClO₄/Propylene Carbonate Solutions

<u>Electrolyte Concentration</u>	<u>Concentration of Cu⁺⁺ (mg/liter)</u>
0.0025 FLiClO ₄ in P.C.	0.6
0.01 FLiClO ₄ in P.C.	1.3
0.025 FLiClO ₄ in P.C.	1.7
0.05 FLiClO ₄ in P.C.	2.1
0.10 FLiClO ₄ in P.C.	1.8
0.25 FLiClO ₄ in P.C.	3.1
0.75 FLiClO ₄ in P.C.	3.6
1.0 FLiClO ₄ in P.C.	3.0

Table 3

Spectrographic Analysis of LiClO₄

	<u>Impurity in Parts Per Million</u>						
	<u>Si</u>	<u>Cu</u>	<u>Mg</u>	<u>Ti</u>	<u>Ca</u>	<u>Al</u>	<u>Fe</u>
As received	100	50	50	10	100	10	10
Ether recrystallized	1	50	50	1	50	10	1
Water and ether recrystallized	10	50	10	1	50	10	1
Water recrystallized	100	50	50	1	50	10	10

Table 4

CuF₂ Solubility in Various Types of Electrolyte

<u>Electrolyte</u>	<u>CuF₂ Solubility in mg Cu per liter</u>
1M LiClO ₄ (twice recrystallized from water) in twice distilled P.C.	10
1M LiClO ₄ (twice recrystallized from water and once from ether) in twice distilled P.C.	22
1M LiClO ₄ (as-received) in once distilled P.C.	24
1M LiClO ₄ (once recrystallized from ether) in twice distilled P.C.	46
1M LiClO ₄ (once recrystallized from ether) in twice distilled P.C. with 1% (by volume) water added.	1760

Table 5

Spectrographic Analysis of Purified Graphite

	SW1651 (unpurified) ppm	SW1651 (purified with HNO ₃) ppm	SW1651 (purified with HCl) ppm	SW1651 (purified with HCl and HNO ₃) ppm
Mg	1000	10	100	10
Si	1000	1000	1000	1000
Al	1000	1000	1000	100
Fe	1000	100	10	10
Mn	100	1	1	1
MO	500	10	500	10
V	50	10	10	10
Ti	100	50	10	10
Na	100	1000	1000	1
Ca	100	50	10	10
B	n. d.	50	10	50

Table 6

Concentration LiClO ₄ / propylene carbonate (formal)	Current Density (ma/cm ²)	τ Transition Time (min.)	$\frac{i/\tau}{C}$
1.0	13.3	40	84
1.0	18.2	23.5	88
1.0	23.4	11.7	80
0.5	11.6	13	83.5
0.5	15	8	84.6
0.25	10	2.5	82.1
0.25	13.3	2.6	85
0.25	20.7	1.0	82.8

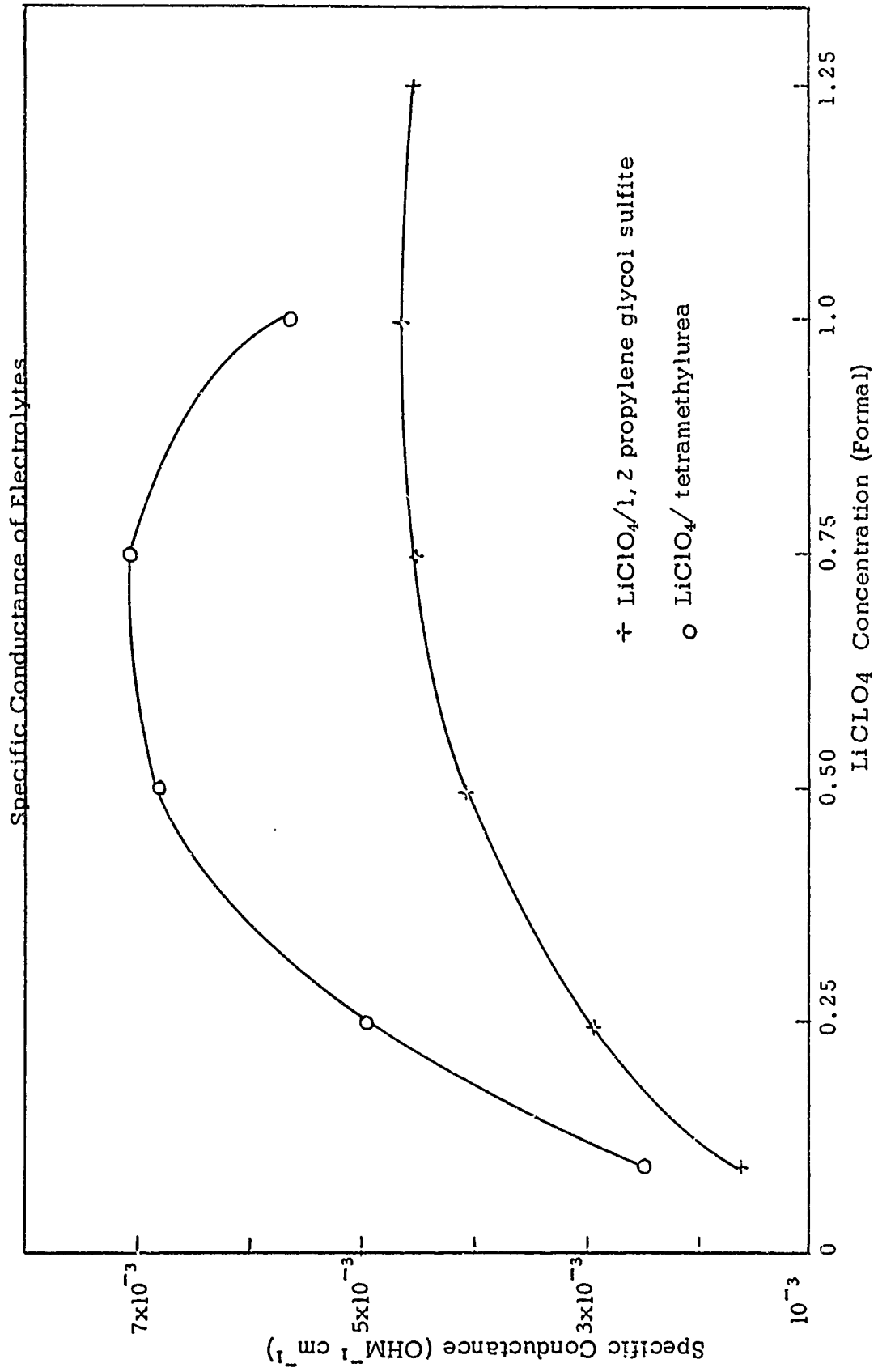

Figure 1

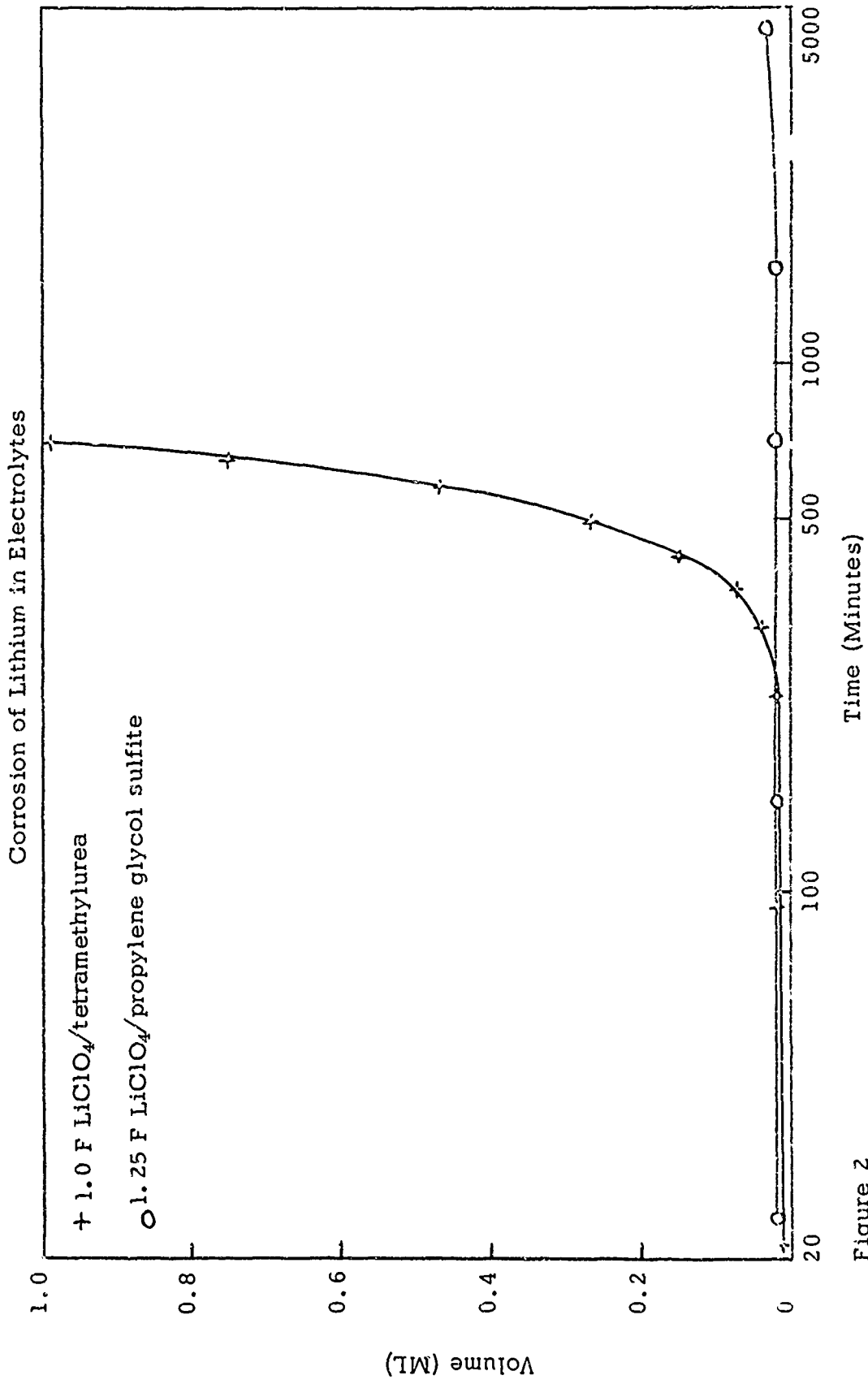

Figure 2

Cupric Fluoride Solubility vs. Time

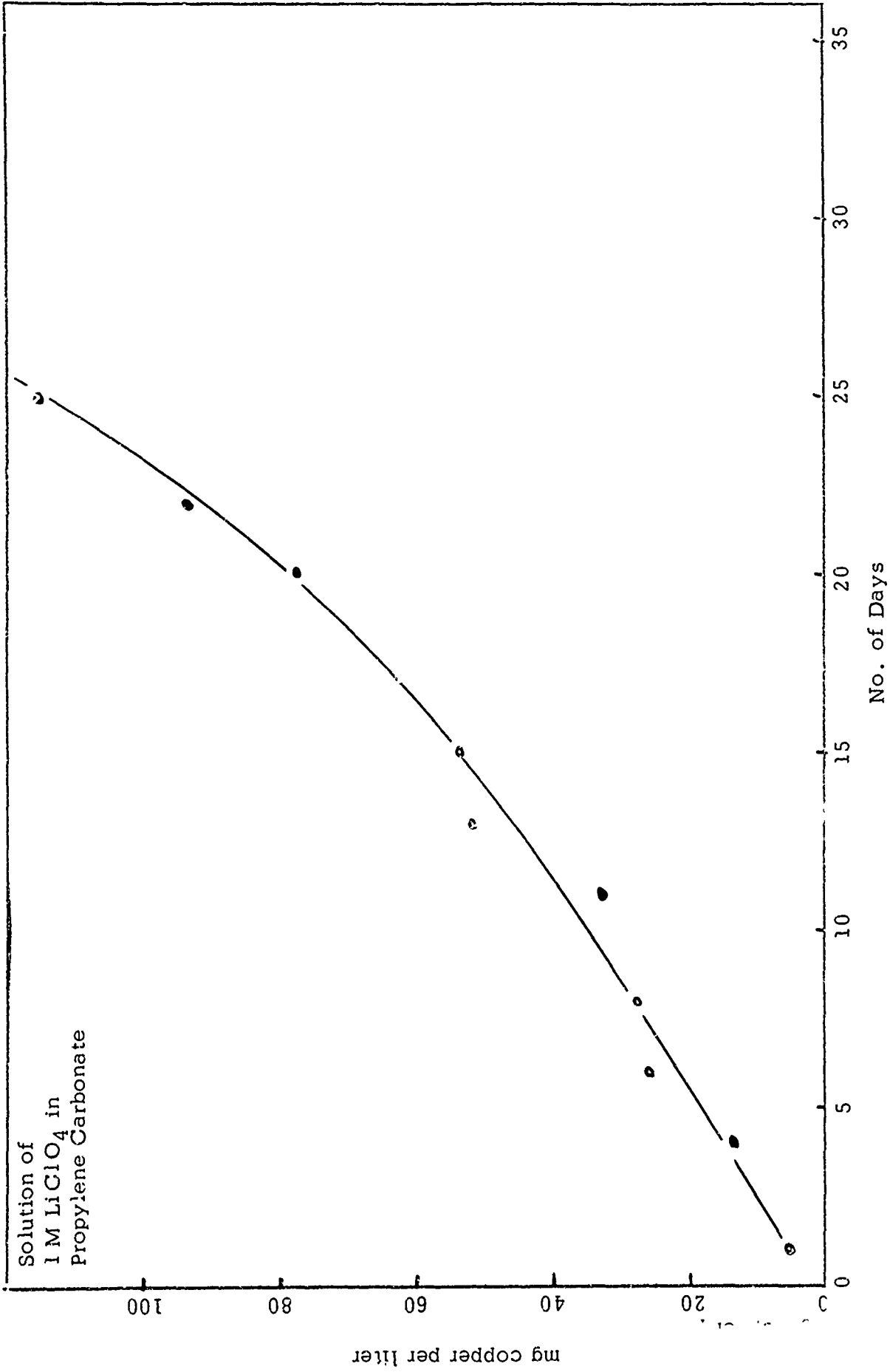

Figure 3

Effect of Cathode Activated Stand on Performance -
Electrodes Made with Unpurified SW1651 Graphite

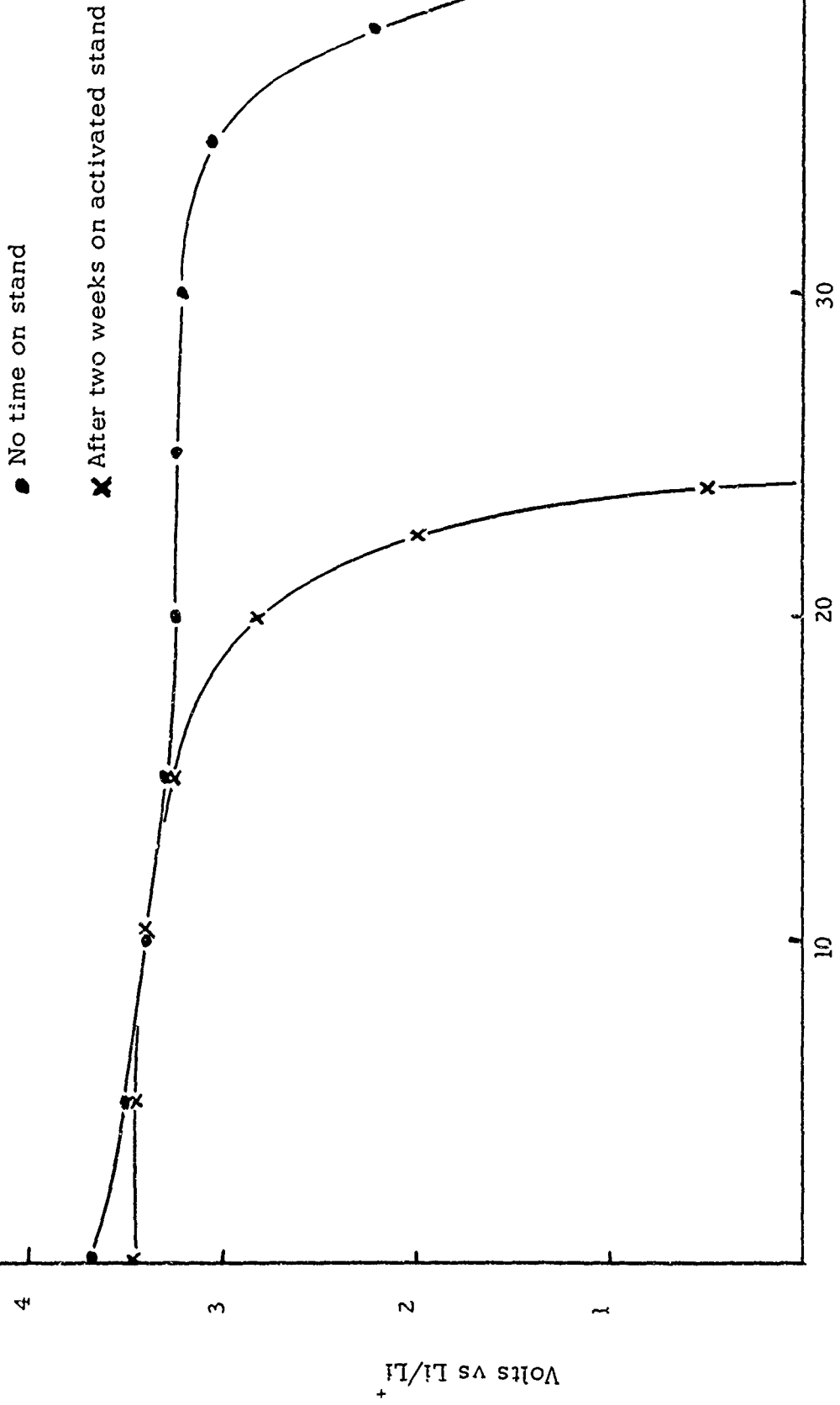

Figure 4
Percent Utilization of CuF₂

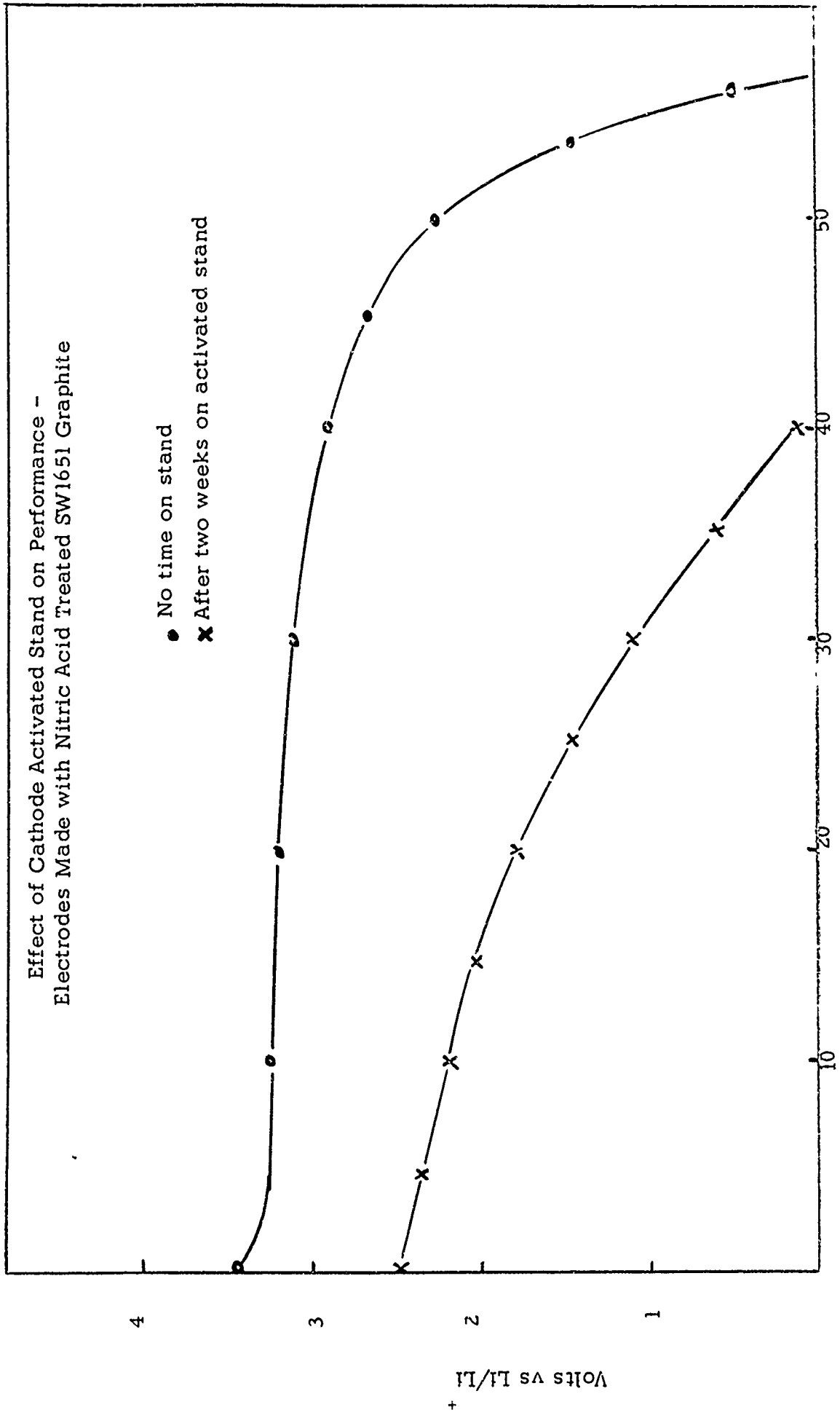

Figure 5
Percent Utilization of CuF_2

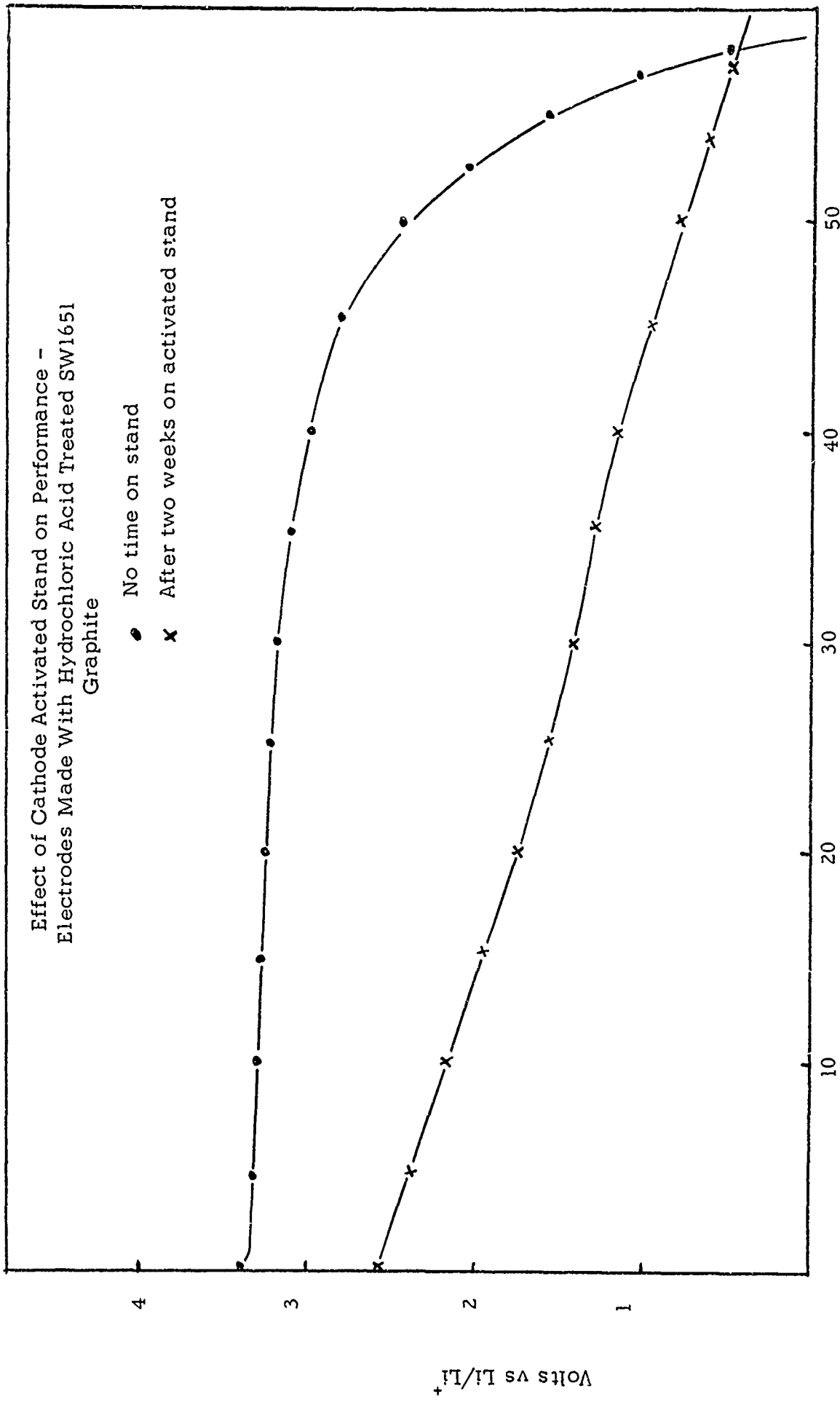

Figure 6

Percent Utilization of CuF₂

Volts vs Li/Li+

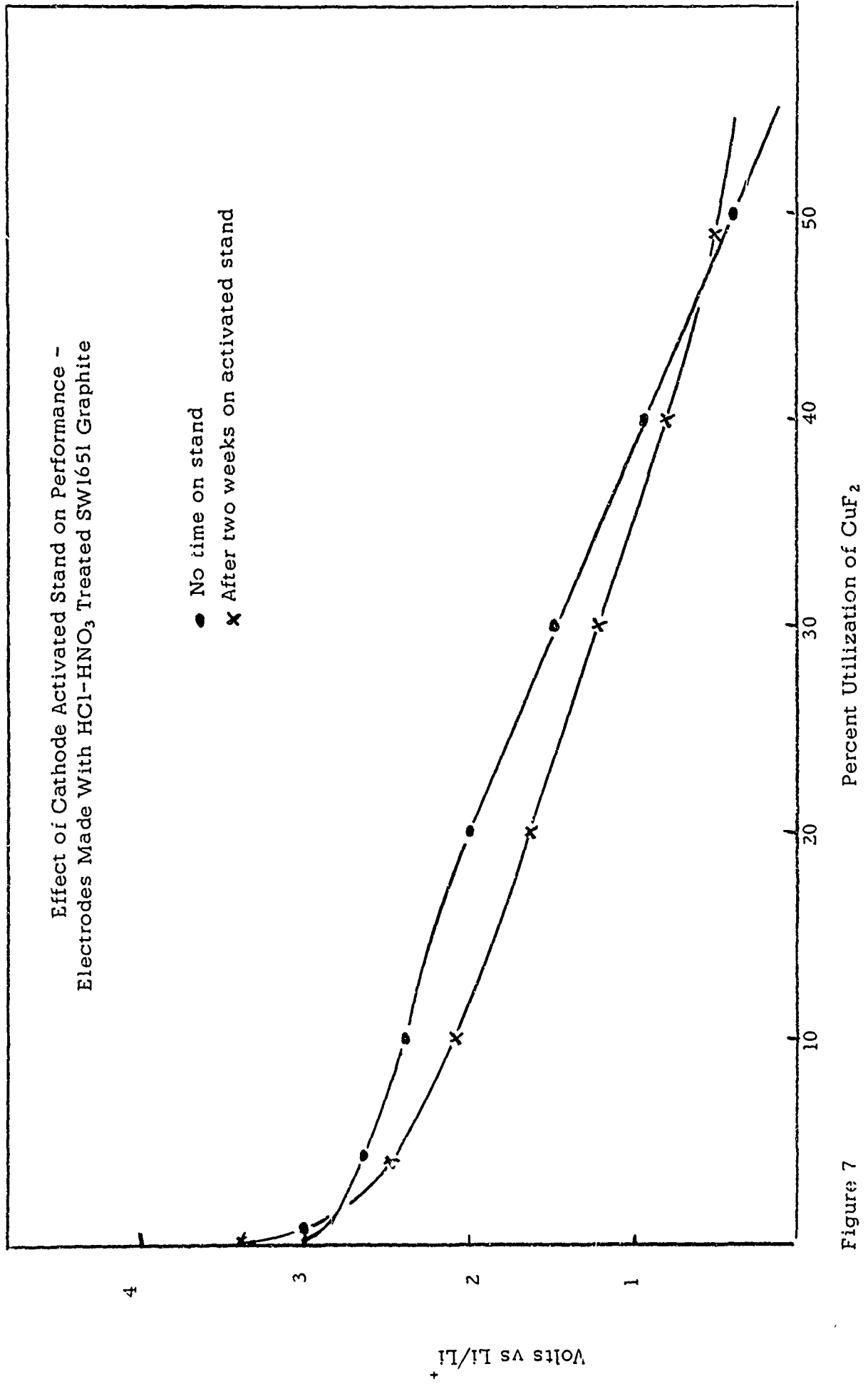

Figure 7

Effect of Purification of Graphite on Activated Cell Stand Performance -
Electrodes Pressed at . . . 500 lbs. per cm²

- Untreated graphite with no stand
- ◐ Untreated graphite with 1 week activated stand
- × HCl-HNO₃ purified graphite with no stand
- ◑ HCl-HNO₃ purified graphite with one week activated stand

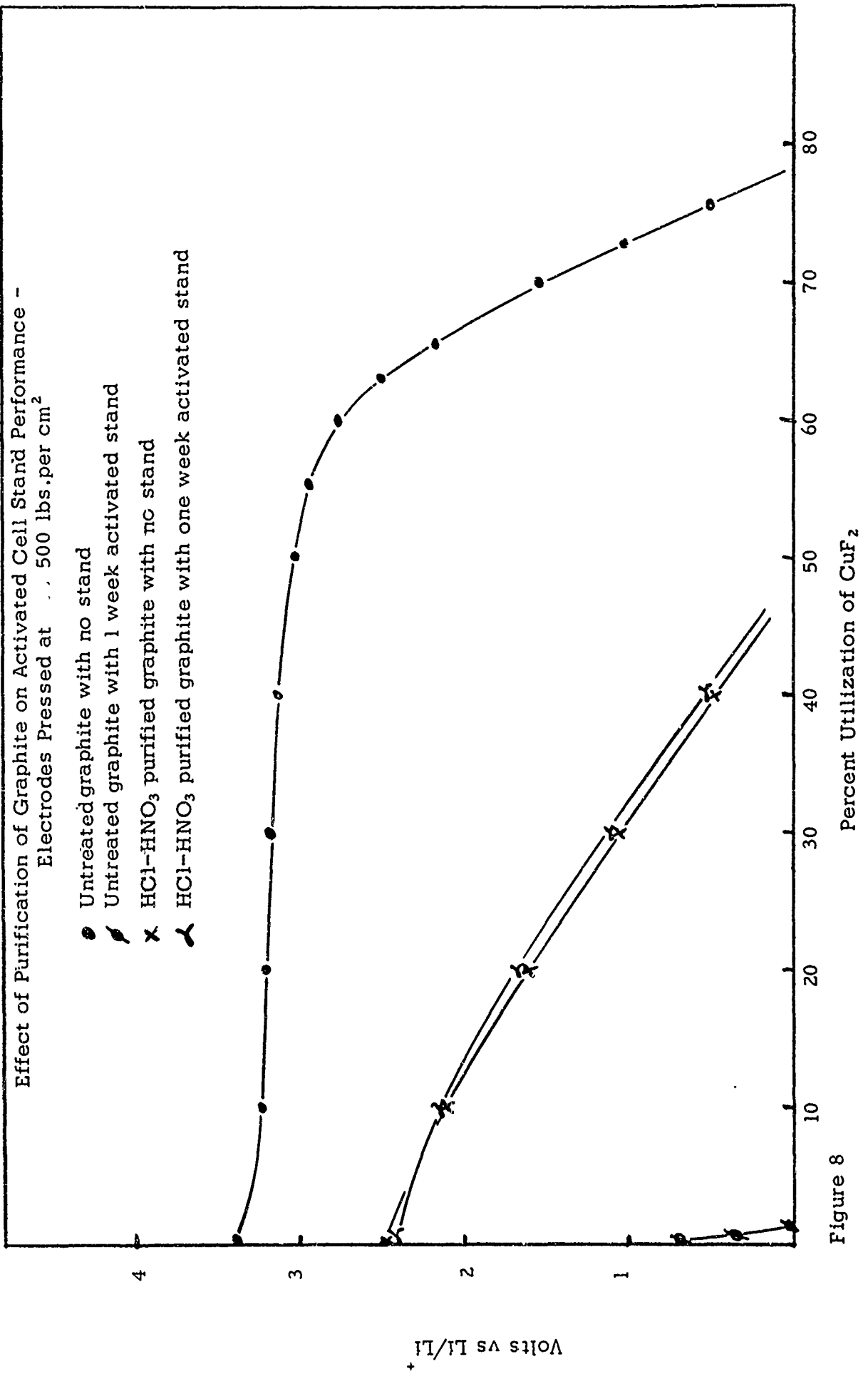

Figure 8

Effect of Ethylene Diamine Complexone on CuF_2 Cathode Performance

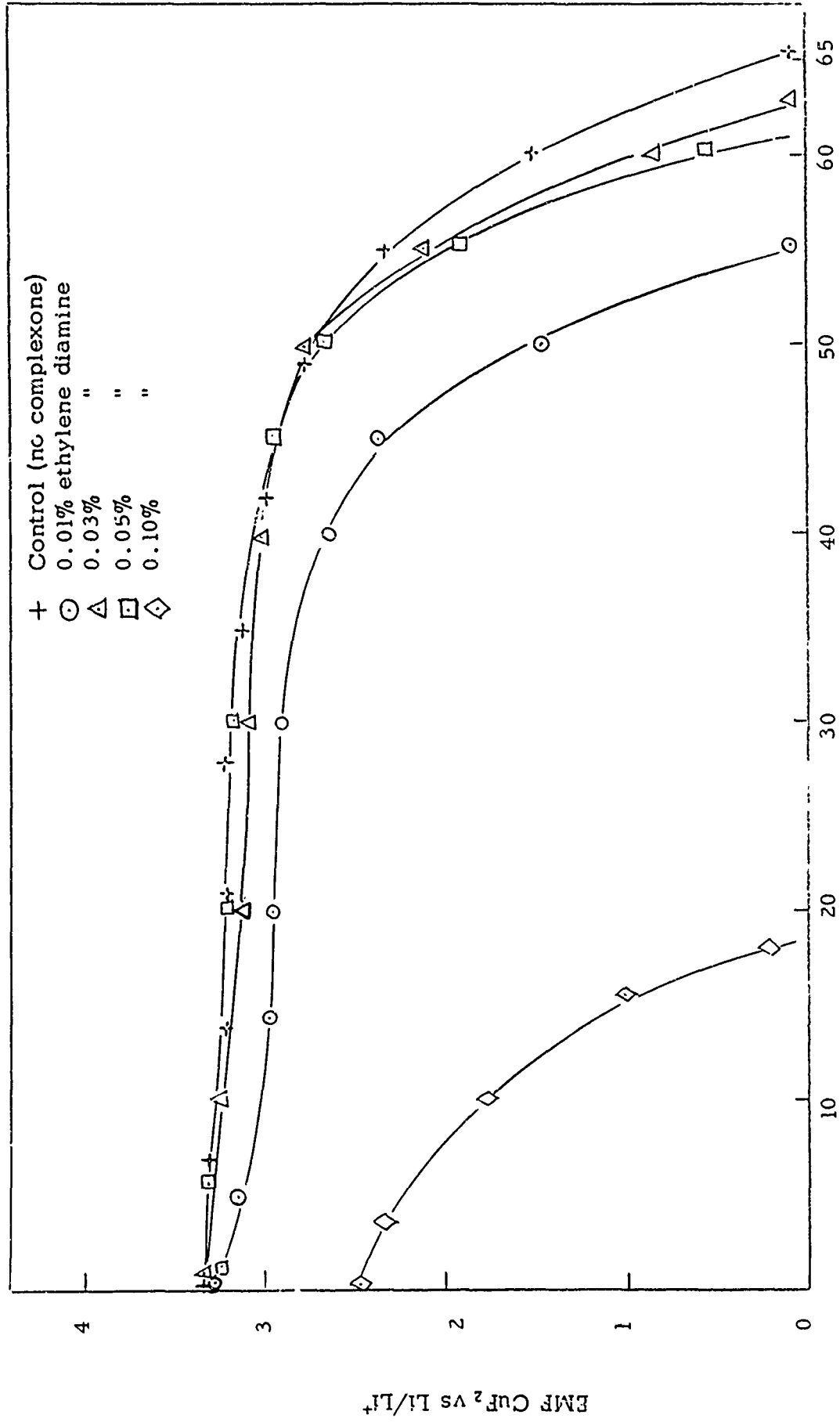

Figure 9

Effect of Diethylene Triamine Complexone on CuF_2 Cathode Performance

Effect of Diethylene Triamine Complexone on CuF_2 Cathode Performance

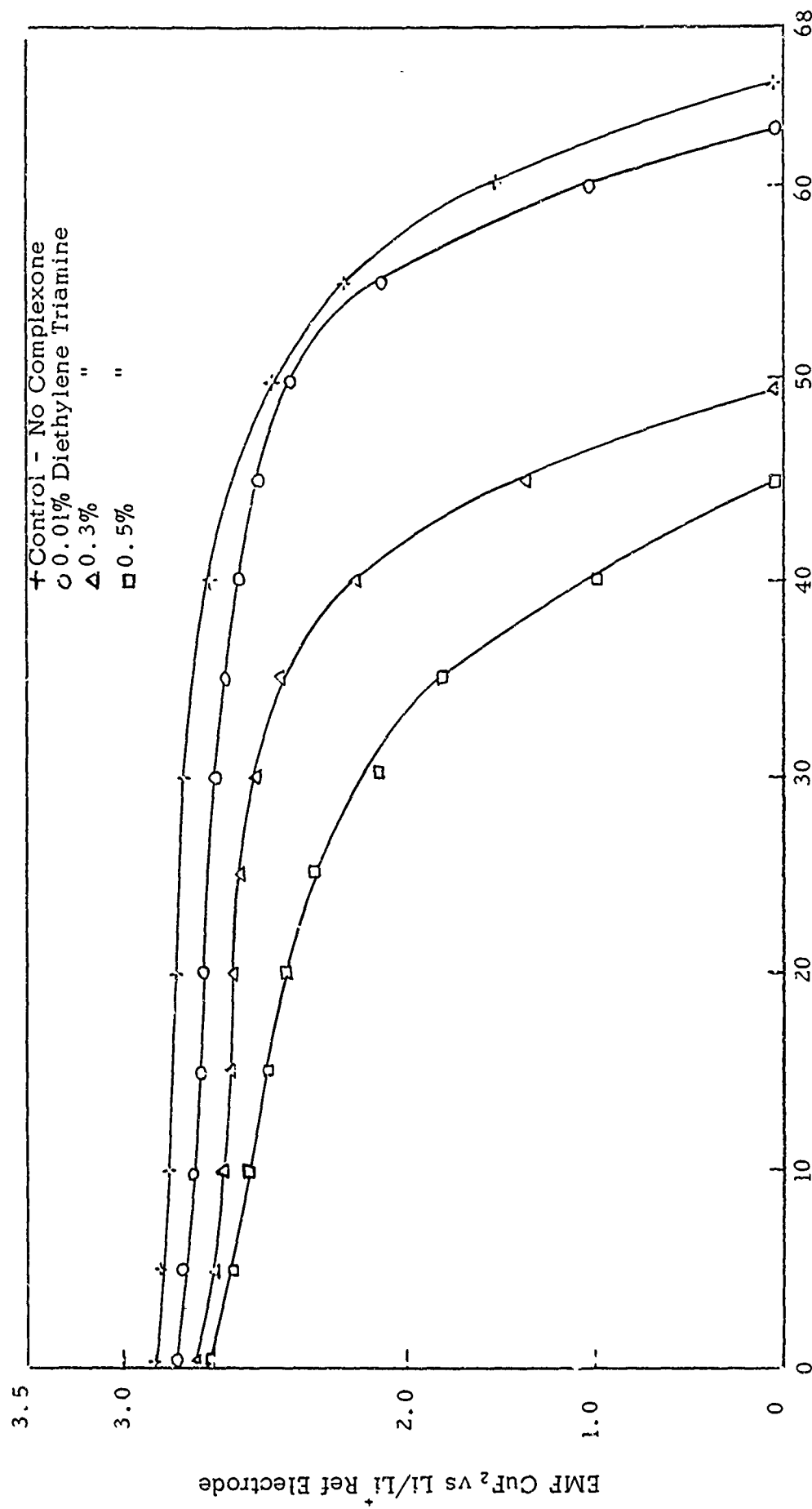

Figure 10

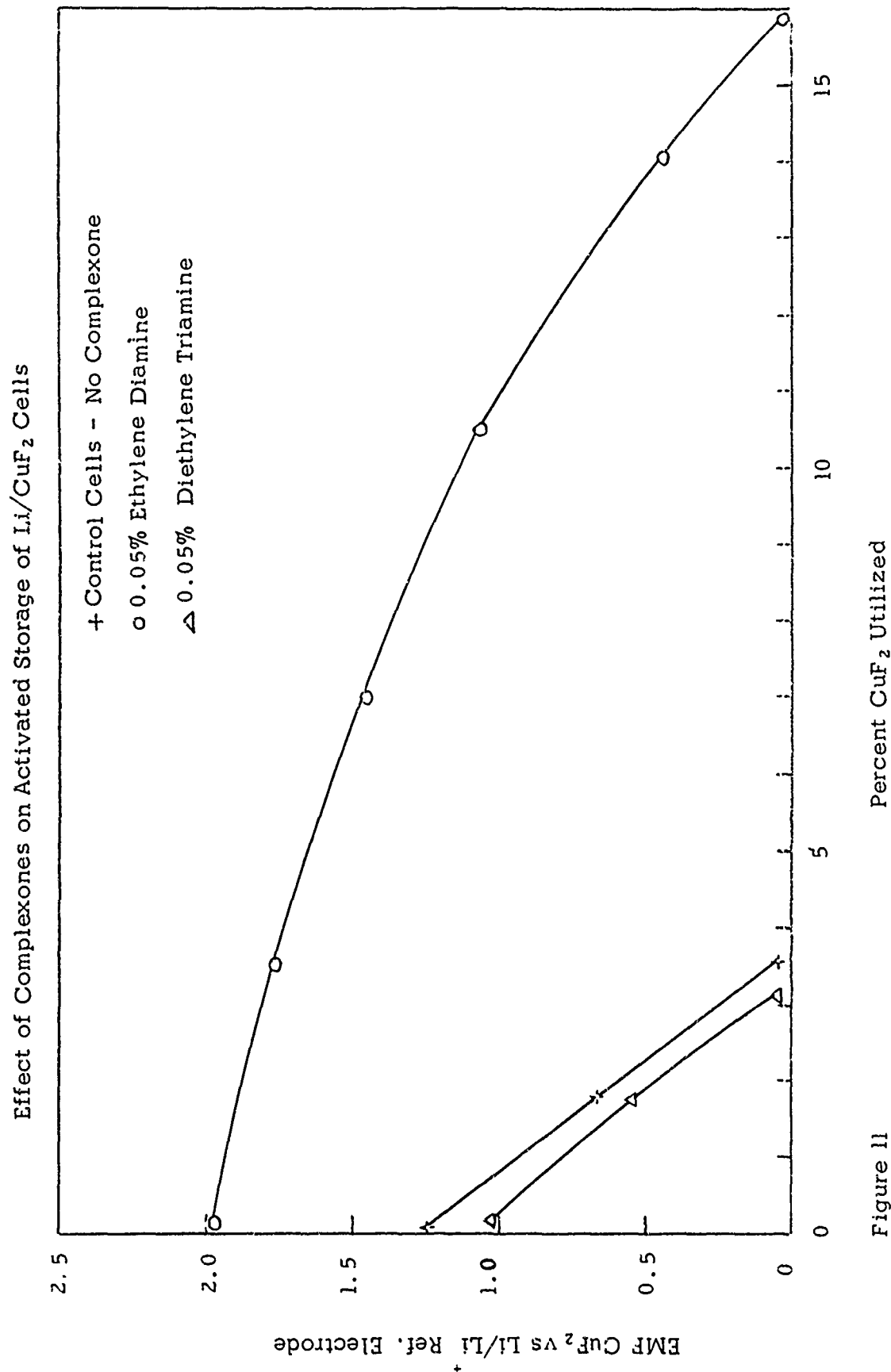

Figure 11

Performance of CuF_2 Cathodes in 1.25 F $\text{LiClO}_4/1, 2$ Propylene Glycol Sulfite

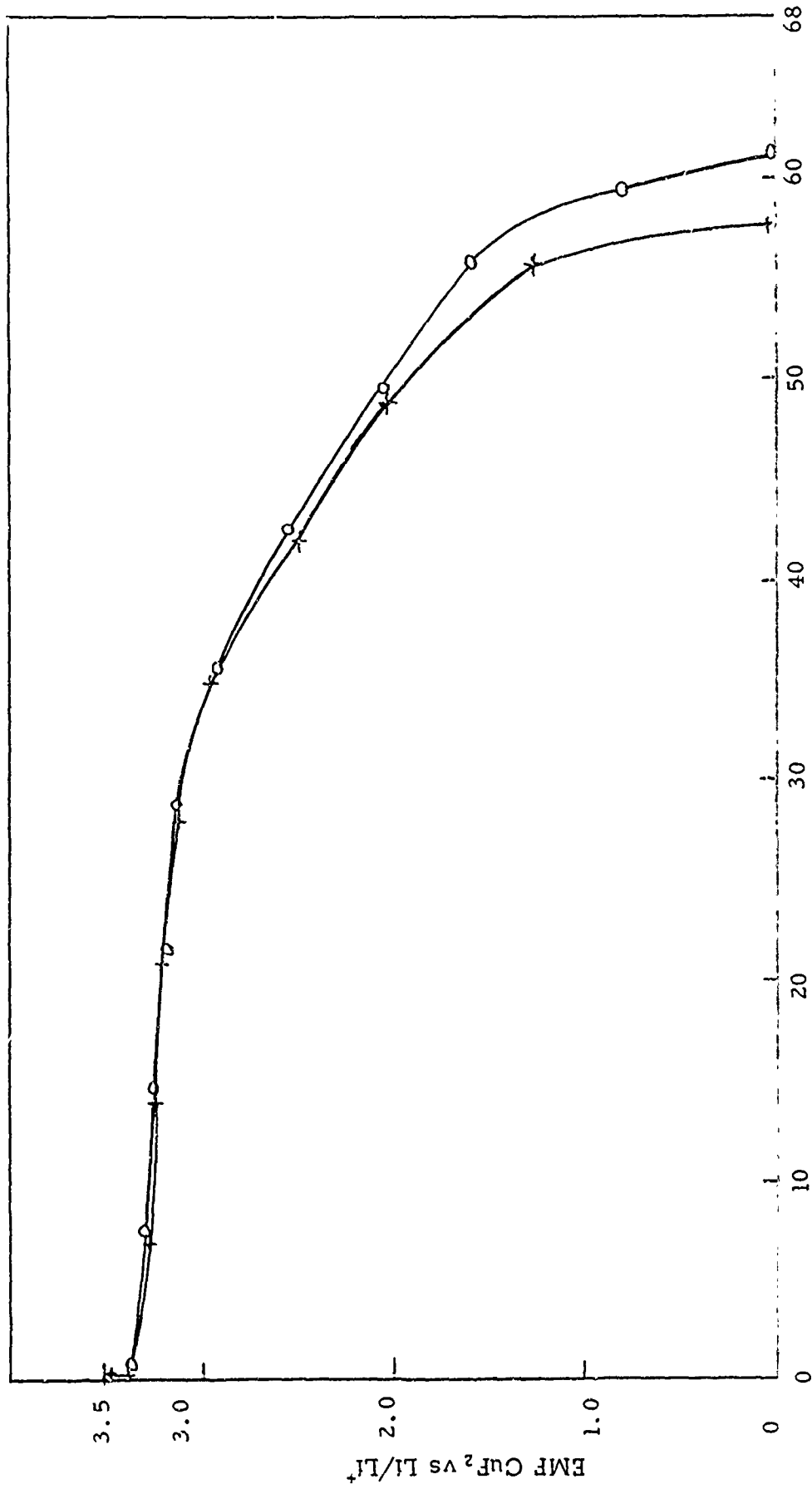

Figure 12

Chronopotentiograms of CuF_2 Cathode Discharge (0.25 F LiClO_4 /Propylene Carbonate)

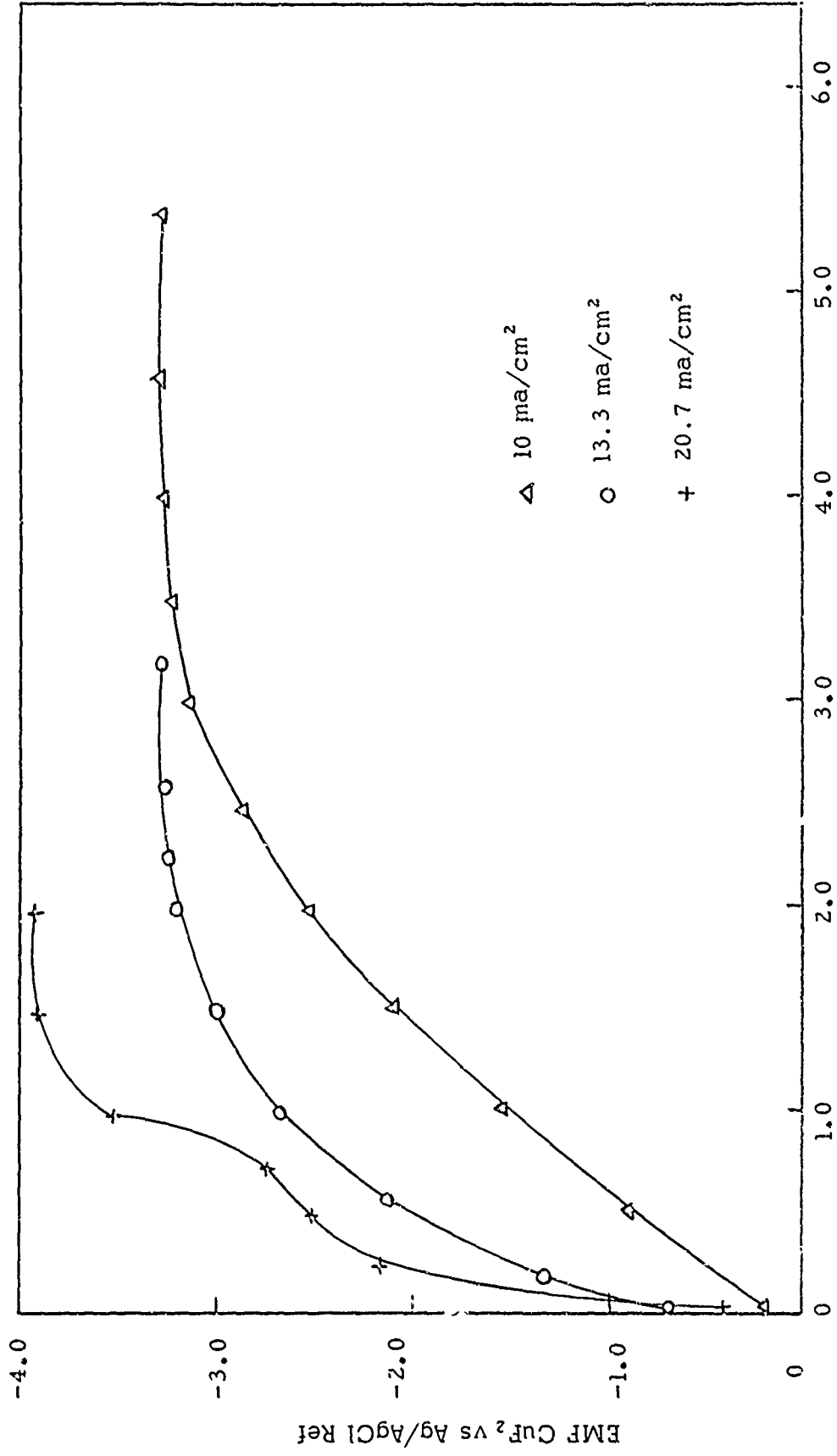

Figure 13

Chronopotentiograms of CuF_2 Cathode Discharge (0.5 F $\text{LiClO}_4/\text{Propylene Carbonate}$)

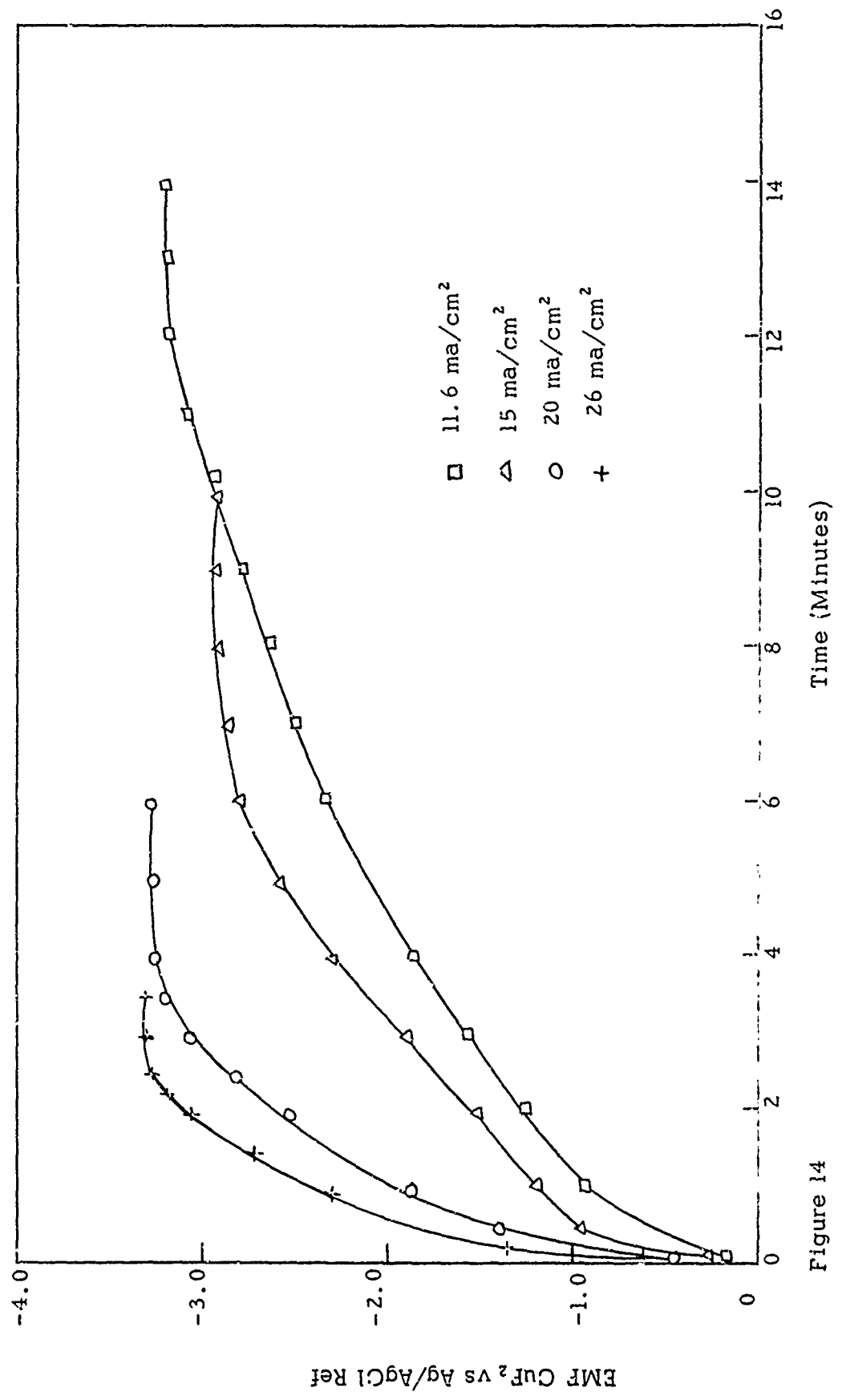

Figure 14

Chronopotentiograms - CuF_2 Cathods (1.0 F LiClO_4 /Propylene Carbonate)

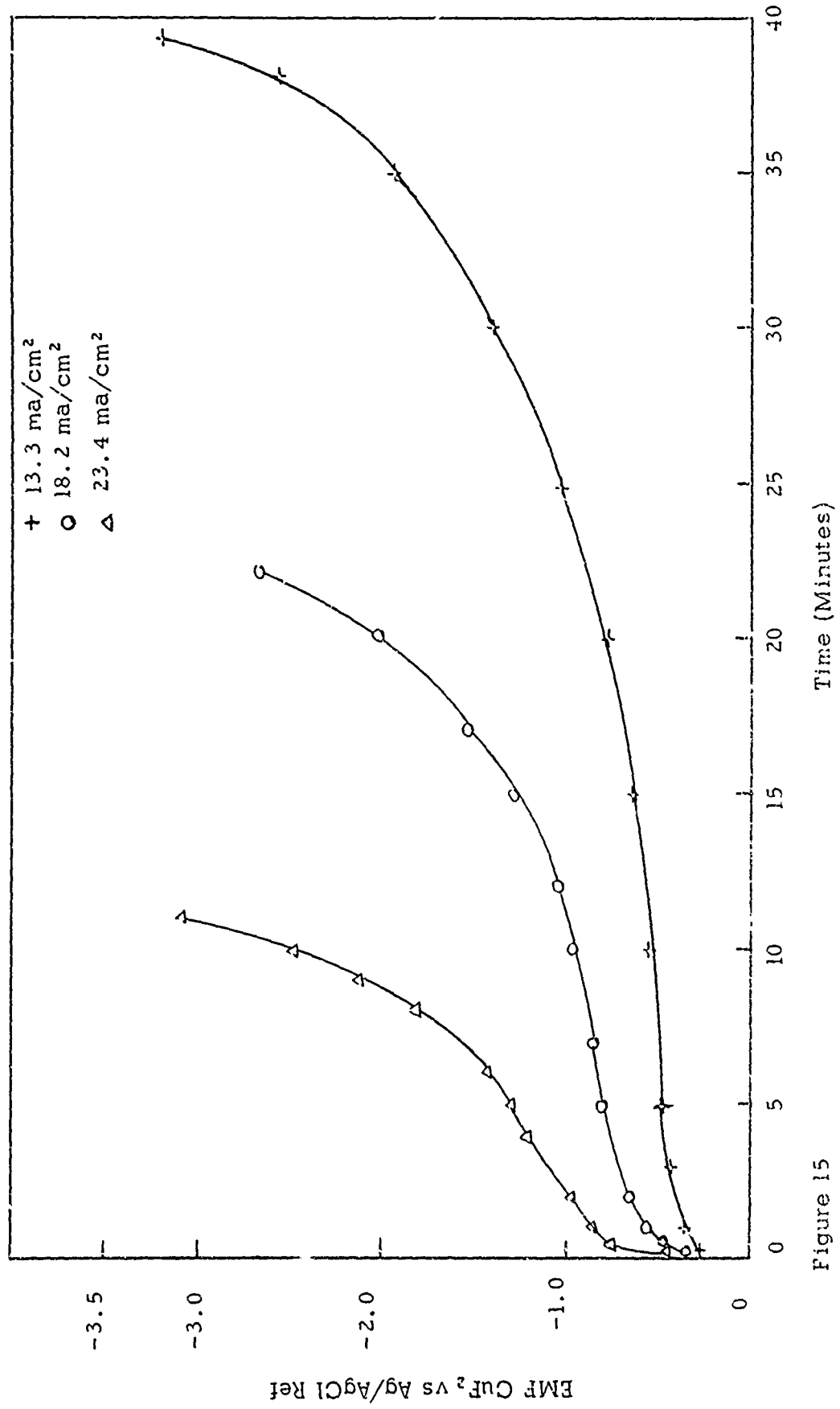

Figure 15

Potential-Time Transient

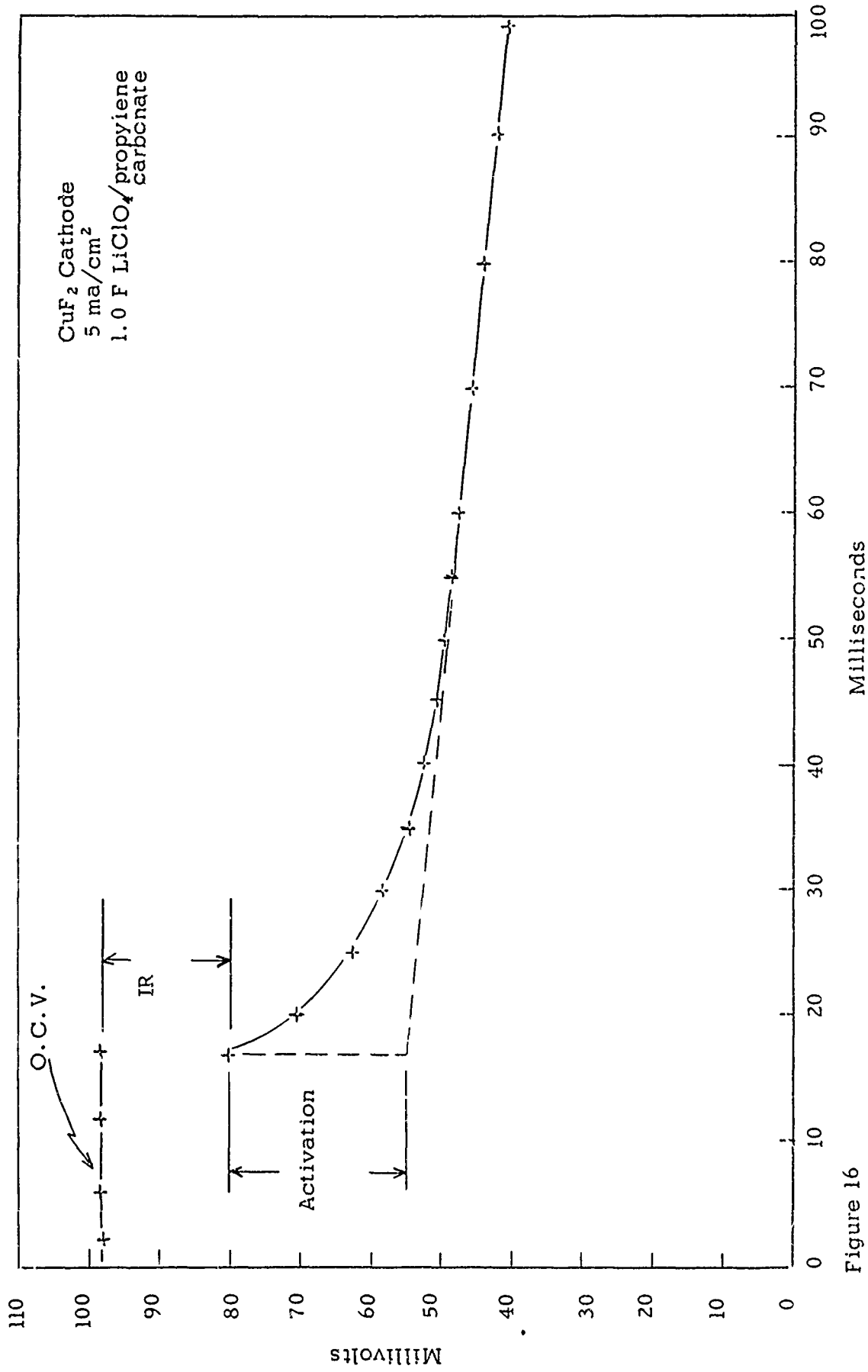

Figure 16

Current Sweep Voltammetry CuFW Cathodes 0.25 F LiClO₄/P°C°

Current Sweep Voltammetry CuF₂ Cathodes(0.25 F LiClO₄/P.C.)

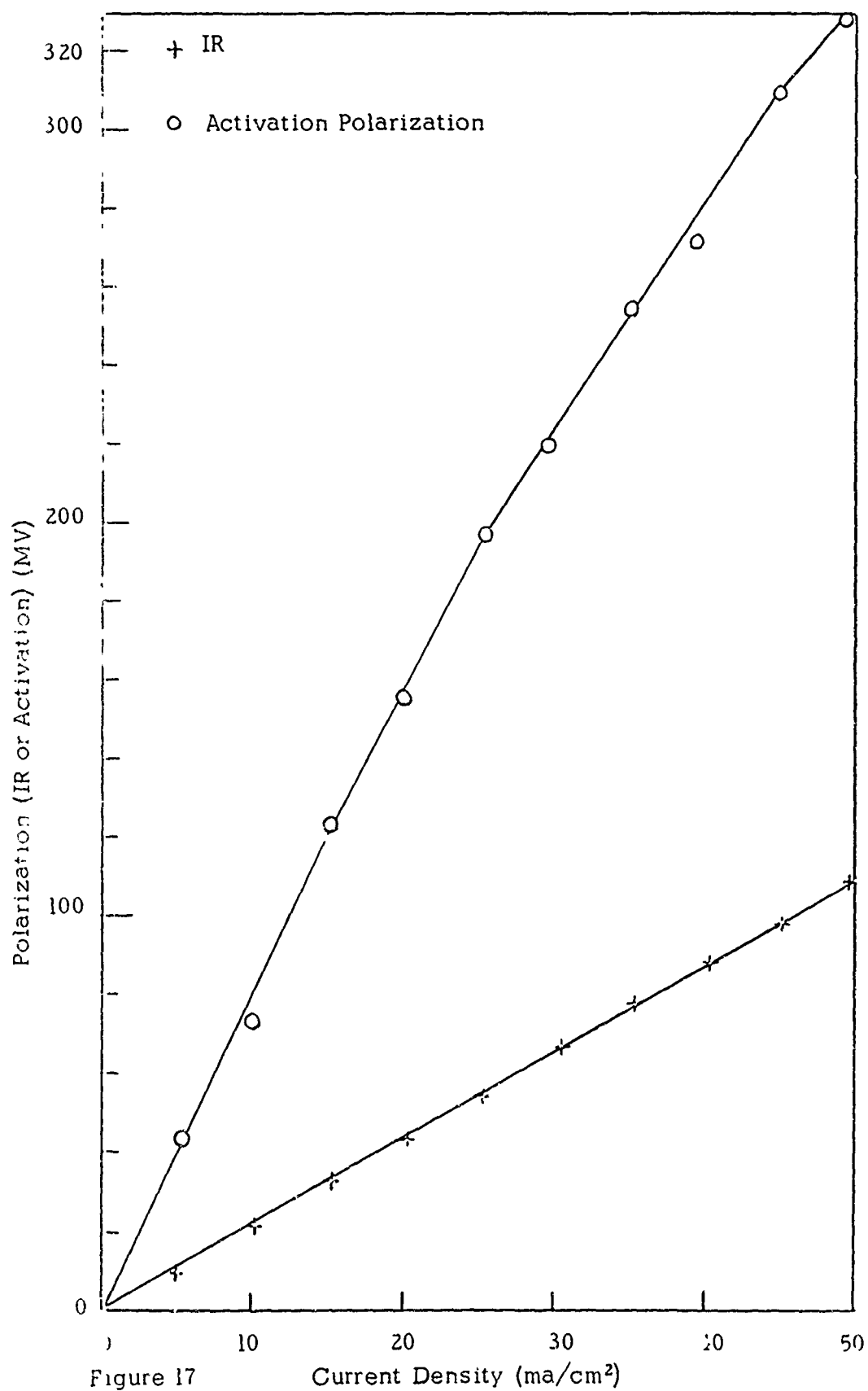

Figure 17

Current Density (ma/cm²)

Current Sweep Voltammetry CuF_2 Cathodes (0.5 F LiClO_4 /
Propylene Carbonate)

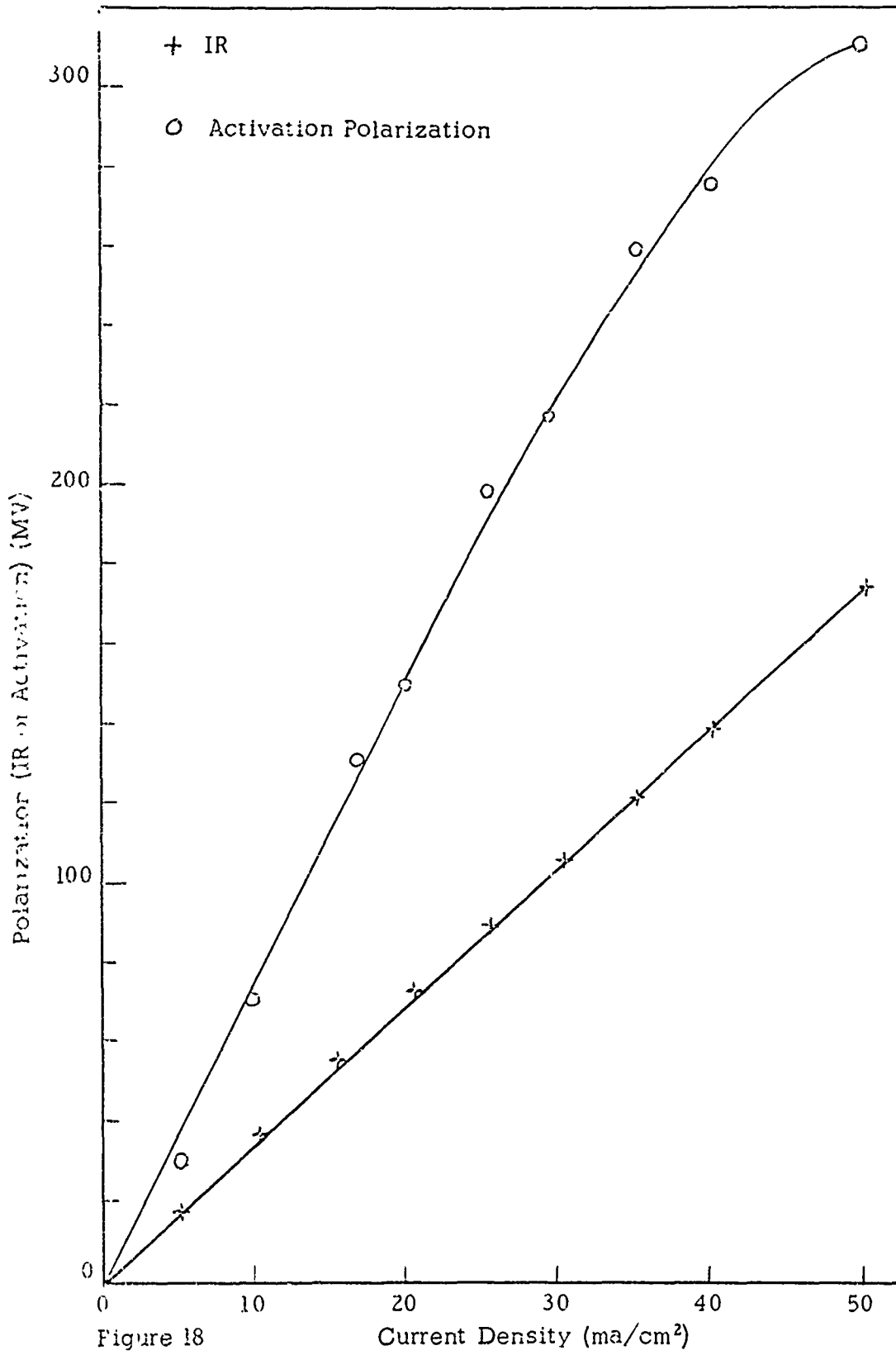

Figure 18

Current Sweep Voltammetry
CuF₂ Cathode in 1F LiClO₄/P.C.

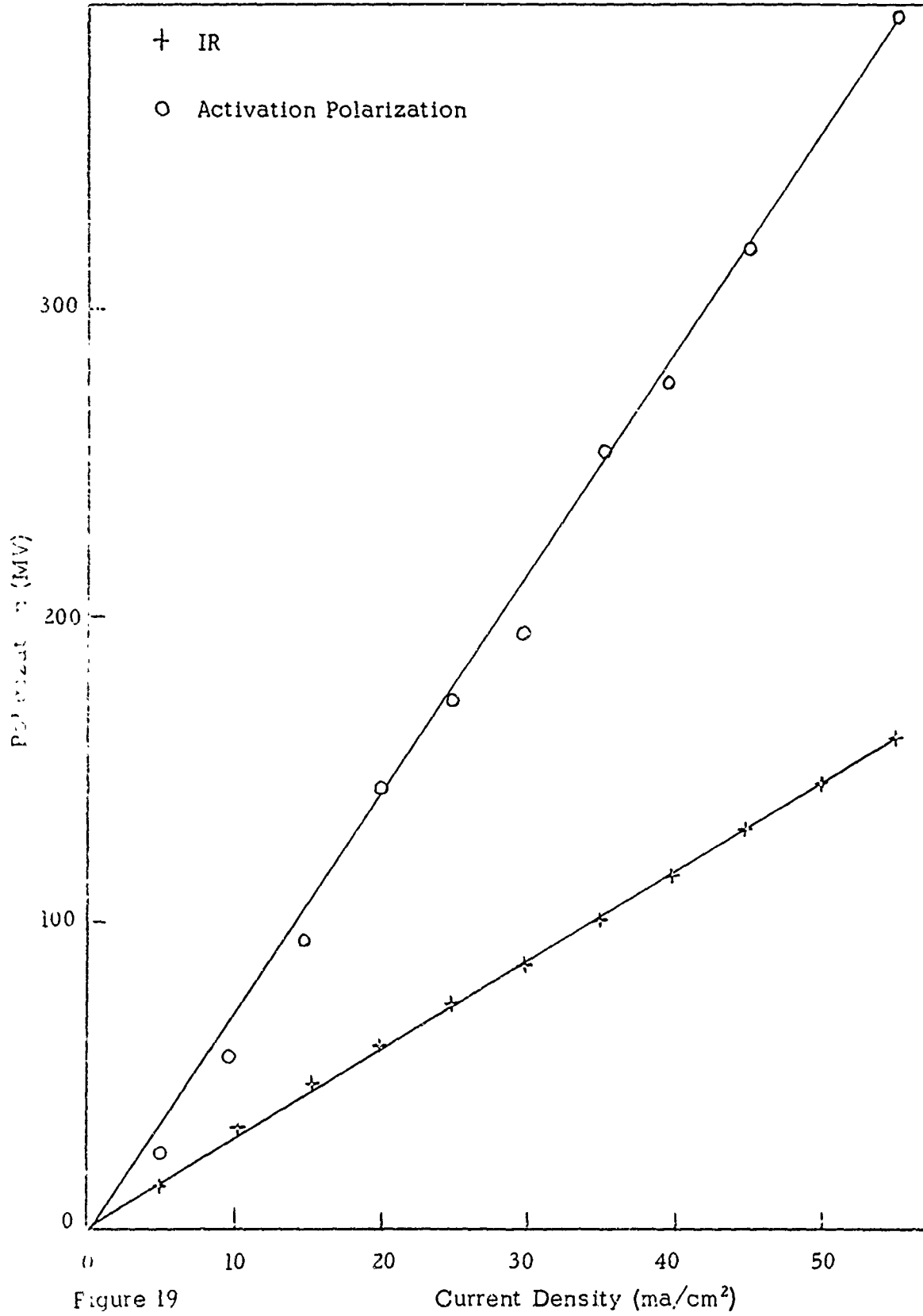

Figure 19

Mercury Pool Cell

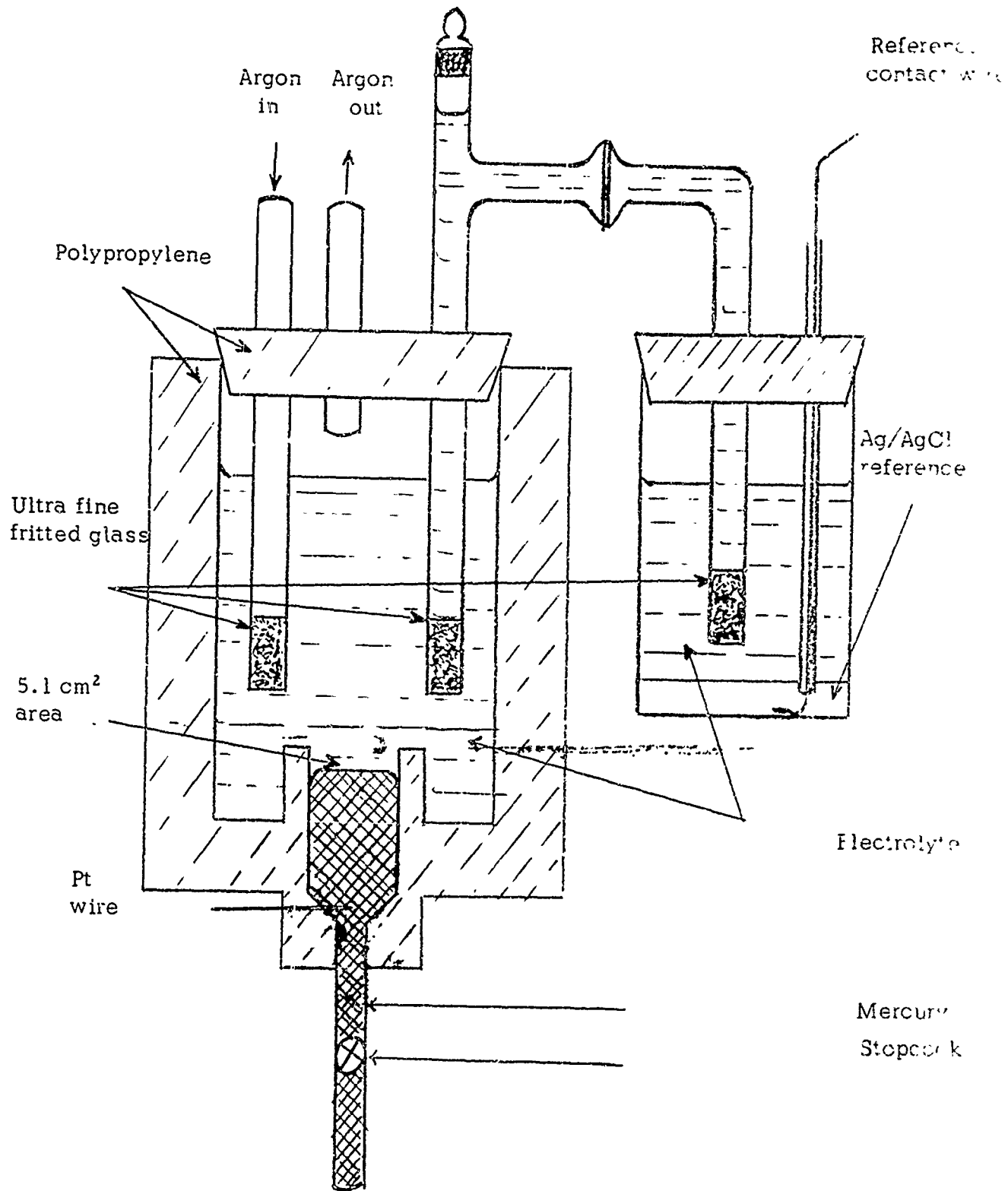

Figure 20

Abstract (cont!)

cells. However, the effect was only marginal.

Kinetic studies of Cu^{2+} cathodes appear to show that the reaction is diffusion limited in LiClO_4 /propylene carbonate electrolytes.

A study of voltammetry in a mercury pool cell was initiated to determine the copper species in electrolyte containing dissolved CuF_2 . Preliminary investigations and cell design are in progress and experimental results should be available in the fourth quarter.

Security Classification

DOCUMENT CONTROL DATA - R&D

(No article or division of title, body of abstract and indexing annotation must be entered when the overall report is classified)

1. ORIGINATING ACTIVITY (Corporate author) The Electric Storage Battery Company and Carl S. Norberg Research Center Reading, Pennsylvania		2a. REPORT SECURITY CLASSIFICATION Unclassified	
3. REPORT TITLE HIGH ENERGY SYSTEM (ORGANIC ELECTROLYTE)		2b. GROUP	
4. DESCRIPTIVE NOTES (Type of report and inclusive dates) Quarterly - 15 December 1966 to 15 March 1967			
5. AUTHOR(S) (Last name, first name, initial) Dennis, L. R., Smith, V. J.			
6. REPORT DATE Jan 1967	7a. TOTAL NO. OF PAGES	7b. NO. OF REFS	
8a. CONTRACT OR GRANT NO. DA-28-043 AMC-02304(E)	9a. ORIGINATOR'S REPORT NUMBER(S)		
a. SUBJECT NO. 100 14501 A 34A	9b. OTHER REPORT NO(S) (Any other numbers that may be assigned this report) ECC1-02304-3		
c. -00 Fuel No.			
d. Report No. -09			
10. AVAILABILITY/LIMITATION NOTICES The number of this document is unlimited			
11. SUPPLEMENTARY NOTES		12. SPONSORING MILITARY ACTIVITY Commanding General U.S. Army Electronics Command Fort Monmouth, N.J. 07703 (AMSEL-KI-PB)	
13. ABSTRACT This report includes the results of investigations on the Li/CuF ₂ system during the first quarter of contract No. DA 28-043 AMC-02304(E), "High Energy System - Organic Electrolyte." During search for new organic electrolytes, tetramethylurea and propylene glycol sulfite were investigated as electrolyte solvents and the latter compound was found to be promising. A re-evaluation of the effect of electrolyte concentration on CuF ₂ solubility revealed that solubility increased as the concentration increased over the range 2.5 x 10 ⁻³ to 1.0M LiClO ₄ /propylene carbonate. The solubility of CuF ₂ in electrolyte was studied as a function of time and it was found that the concentration increased with time over a period of 25 days. Purification treatments were applied to LiClO ₄ and the effect of these salts in propylene carbonate on the CuF ₂ solubility was studied. The lowest solubility was found in solutions containing LiClO ₄ purified from water and made anhydrous, but the results were somewhat inconclusive and indicate a need for further investigation. Commercial 1651 graphite was purified by various methods and it was found that the activated storage of CuF ₂ cathodes thereby improved. The improvement was observed in the activated storage of Li/CuF ₂ cells. The results were re-evaluated and ethylene diamine at a level of 0.05% in propylene carbonate was found to improve activated storage of Li/CuF ₂			

(Continued on Attached Sheet)

FOR JAN 1967 73

Security Classification

Security Classification

14. KEY WORDS	LINK A		LINK B		LINK C	
	ROLE	WT	ROLE	WT	ROLE	WT
High energy density battery Organic electrolyte battery Non-aqueous electrolyte battery Shelf life Self-discharge Rate Capability Lithium anode Cupric Fluoride Cathode						

INSTRUCTIONS

1. **ORIGINATING ACTIVITY:** Enter the name and address of the contractor, subcontractor, grantee, Department of Defense activity or other organization (*corporate author*) issuing the report.
- 2a. **REPORT SECURITY CLASSIFICATION:** Enter the overall security classification of the report. Indicate whether "Restricted Data" is included. Marking is to be in accordance with appropriate security regulations.
- 2b. **GROUP:** Automatic downgrading is specified in DoD Directive 5200.10 and Armed Forces Industrial Manual. Enter the group number. Also, when applicable, show that optional markings have been used for Group 3 and Group 4 as authorized.
3. **REPORT TITLE:** Enter the complete report title in all capital letters. Titles in all cases should be unclassified. If a meaningful title cannot be selected without classification, show title classification in all capitals in parenthesis, immediately following the title.
4. **DESCRIPTIVE NOTES:** If appropriate, enter the type of report, e.g., interim, progress, summary, annual, or final. Give the inclusive dates when a specific reporting period is covered.
5. **AUTHOR(S):** Enter the name(s) of author(s) as shown on or in the report. Enter last name, first name, middle initial. If military, show rank and branch of service. The name of the principal author is an absolute minimum requirement.
6. **REPORT DATE:** Enter the date of the report as day, month, year, or month, year. If more than one date appears on the report, use date of publication.
- 7a. **TOTAL NUMBER OF PAGES:** The total page count should follow normal pagination procedures, i.e., enter the number of pages containing information.
- 7b. **NUMBER OF REFERENCES:** Enter the total number of references cited in the report.
- 8a. **CONTRACT OR GRANT NUMBER:** If appropriate, enter the applicable number of the contract or grant under which the report was written.
- 8b, 8c, & 8d. **PROJECT NUMBER:** Enter the appropriate military department identification, such as project number, subproject number, system numbers, task number, etc.
- 9a. **ORIGINATOR'S REPORT NUMBER(S):** Enter the official report number by which the document will be identified and controlled by the originating activity. This number must be unique to this report.
- 9b. **OTHER REPORT NUMBER(S):** If the report has been assigned any other report numbers (*either by the originator or by the sponsor*), also enter this number(s).

10. **AVAILABILITY/LIMITATION NOTICES:** Enter any limitations on further dissemination of the report, other than those imposed by security classification, using standard statements such as:

- (1) "Qualified requesters may obtain copies of this report from DDC."
- (2) "Foreign announcement and dissemination of this report by DDC is not authorized."
- (3) "U. S. Government agencies may obtain copies of this report directly from DDC. Other qualified DDC users shall request through _____."
- (4) "U. S. military agencies may obtain copies of this report directly from DDC. Other qualified users shall request through _____."
- (5) "All distribution of this report is controlled. Qualified DDC users shall request through _____."

If the report has been furnished to the Office of Technical Services, Department of Commerce, for sale to the public, indicate this fact and enter the price, if known.

11. **SUPPLEMENTARY NOTES:** Use for additional explanatory notes.
12. **SPONSORING MILITARY ACTIVITY:** Enter the name of the departmental project office or laboratory sponsoring (*paying for*) the research and development. Include address.
13. **ABSTRACT:** Enter an abstract giving a brief and factual summary of the document indicative of the report, even though it may also appear elsewhere in the body of the technical report. If additional space is required, a continuation sheet shall be attached.

It is highly desirable that the abstract of classified reports be unclassified. Each paragraph of the abstract shall end with an indication of the military security classification of the information in the paragraph, represented as (TS), (S), (C), or (U).

There is no limitation on the length of the abstract. However, the suggested length is from 150 to 225 words.

14. **KEY WORDS:** Key words are technically meaningful terms or short phrases that characterize a report and may be used as index entries for cataloging the report. Key words must be selected so that no security classification is required. Identifiers, such as equipment model designation, trade name, military project code name, geographic location, may be used as key words but will be followed by an indication of technical context. The assignment of links, rules, and weights is optional.