

## MEDICAL RESEARCH LABORATORY

Fort Knox, Kentucky

SEP 5 1967

E

Project No. 27

File 400.112

13 March 1944

## FIRE RESISTING COMPOUNDS FOR CLOTHING

1. PROJECT: Test of Compounds - Fire Resisting, for Field Treatment of Clothing - OQMG -253.

a. Authority - Letter, Commanding General, Headquarters Army Ground Forces, Army War College, Washington, D. C., GNRQT-6/68999, January 23, 1944.

b. Purpose - The purposes of the test, as defined by the O.Q.M.G. were:

(1) Evaluation of the ease of field application of two flame retardant compounds to standard issue clothing.

(2) Evaluation of the qualities of treated garments (under anticipated extremes of humidity and temperature) ~~when applicable~~ to include:

*reference to* (a) Comfort,

(b) Irritation or dermatological reactions,

(c) Undue failures of treated garments compared to untreated garments,

(d) Does perspiration or light rain leach out the treatment with such rapidity as to make it ineffective?

(3) Evaluation of the amount of relative protection ~~treatment provides~~ when garment is dry, when wet with perspiration or rain.

(4) Evaluation of the life of the treatment under field conditions.

2. DISCUSSION:

a. Verbal and written reports from combat theaters indicate that burns are very common. They may be caused by ammunition fires, fuels, lubricants, flame throwers, incendiary bombs and shells and a variety of other materials. Clothing affords a very real protection against many of these sources of burns provided the soldier is not in contact with the heat source too long and provided his clothing does not ignite. Too frequently a man



AD 657220

may receive serious burns from his own clothing after he has extricated himself from the original source of the fire. For that reason, a fire retardant in clothing would be a very real advantage.

b. Two compounds, "Flame-out" - Treasdale and "Fire Retardant CM" - Dupont, made commercially for similar purposes, were supplied for test as possible temporary solutions to the problem.

c. Details of the procedure used and the results of the various tests will be found in Appendix A.

### 3. CONCLUSIONS:

a. Both compounds are easily employed in the field provided the garments can be dried in a reasonable length of time (from 2 to 3 hours). This may be difficult or impossible in damp climates.

b. Within the limited ranges of these tests, neither compound appeared to affect materially the life of the garment. (Extended wear and tear tests were not done.)\*

c. Both compounds leach out very quickly in moderate rain or with copious sweating. This renders the "Flame-out" - Treasdale impractical because of loss of effectiveness. In the case of "Fire Retardant CM" however, such a small quantity is actually needed to produce results that the rapid leaching does not destroy the usefulness of the treatment.

d. Comfort, and the heat load imposed by the clothing are not appreciably affected by impregnation with either compound as carried out in the field. (The weight of clothing is increased by approximately 5%)

e. No dermatological reactions were noted with either compound with concentrations of flame retardant in the cloth not in excess of 7% by weight. Higher concentrations were not tried.

f. The charring-time and ignition (glow) time of the impregnated as compared with the untreated fabric at 500°C is not prolonged by either compound.

g. The duration of after-glow and burning when the heat source is removed is materially reduced by both compounds. Unimpregnated HBT will continue to burn until completely incinerated. "Flame-out" stops after-glow when a small hole has developed. "Fire Retardant CM" stops after-glow as soon as the heat source is removed. In equal concentrations it is far superior to "Flame-out".

---

\* The N.D.R.C. research group at Columbia University reports that repeated impregnation will shorten the life of the garment.

h. Protection against burns was measured only with garments impregnated with "Fire Retardant CM" because "Flame-out" was found to be impractical. Clothing treated with the "Fire Retardant CM" as compared with the unimpregnated fabric, gives no increased protection against a burn on human skin from hot air; in fact, the treatment appeared to increase slightly the severity of a burn for constant temperature and time of exposure. This compound does not increase the protection against burns afforded by wet garments. Its great, very real, and only advantage therefore, is that it instantly stops burning in the garment when the heat source is removed (stops after-glow).

i. HBT fatigue clothing impregnated with "Flame Retardant CM" will stand one vigorous hand washing in cold water, without soap, before re-impregnation is necessary.

j. A solution of retardant (10% by weight) in warm or cold water is optimal for field impregnation. Twenty gallons of such a solution will impregnate about 80 fatigue uniforms.

4. RECOMMENDATIONS:

a. That field impregnation of fatigue uniforms with "Fire Retardant CM" be considered an effective temporary measure for stopping fires.

b. "Fire Retardant CM" or other agent of equally desirable characteristics be issued to the following men in the combat zones of all theaters, basis of issue to be 25 pounds per tank company or equivalent.

(1) Tank and other vehicle crews.

(2) Gasoline and ammunition handlers (1st echelon).

(3) Personnel handling or using incendiary agents including flame throwers.

(4) Other personnel designated by unit commanders because of exposure to fire hazards.

c. Instructions be issued for the application of the retardant. A proposed draft is attached (Appendix B).

d. Development of more effective and permanent methods of fire-proofing clothing be continued.

Comments and recommendations of the Armored Medical Research Laboratory concurred with by Colonel Harold G. Holt, Acting C/S Headquarters Armored Center, except as follows:

1. That the burden of impregnating clothing should not be placed on the company nor any other element of the Division in combat because of:

a. Insufficient personnel to do the job.

b. Drying facilities not available.

2. It is recommended that the impregnating agent be issued to the theatre commander in sufficient quantities to process a depot stock, the amount to be determined by him. It is the opinion of this headquarters that impregnating clothing can be facilitated by means available to the theatre commander, such as laundry companies.

3. That immediate steps be taken to prepare clothing in the United States for shipment as requested by the theatre commander.

Prepared by:

Major W. F. Ashe, M.C.

Capt. W. B. Bean, M.C.

APPROVED

*Willard Machle*

WILLARD MACHLE

Colonel, Medical Corps  
Commanding

3 Incl.

#1 - Appendix A - Full Data

#2 - Appendix B - Procedure for use

#3 - Chart - Schematic Drawing of Burning Apparatus

APPENDIX A

1. Material tested - Two flame retardant materials were supplied for field test on suits, working, two piece, Herringbone Twill. They are "Flame-out" - Treasdale, henceforth indicated as retardant No. 1 and "Fire Retardant CM" - Dupont, indicated as retardant No. 2.

2. Application - Twenty pounds of each agent were dissolved in 20 gallons of cold water in a 30 gallon can. Sixteen suits of fatigues, previously dried at 110°F and 20% relative humidity and weighed (within 1 gram), were soaked for 20 minutes each (16 suits in Solution 1, and 16 in solution 2). Each was hand wrung by one man, thoroughly dried and re-weighed under the above conditions. The difference in weights represents the amount of impregnating material taken up. The average for No. 1 was 5% of the total dry weight and for No. 2, 6%. Field application is feasible and easy and requires only a little sun for drying. In deep jungle, drying would not be possible. Where clothing is always wet, impregnation is probably unnecessary because it does not increase protection, as will be shown later.

3. Control suits - Eight control suits were dried and weighed in a similar fashion. These were used in both the heat load and leaching out experiments. When men sweat profusely, they add salt and some detritus to the garments. The average weight gain of control garments, under identical useage, measures this added factor. Consequently, the control suit weight gain was subtracted from suit weight losses in the leaching-out-by-sweat experiments. This correction was not made in the rain experiment because the rain was very cold and the exposure short. There was no sweating during the rain test.

4. Tests - The procedure and data of the several individual tests follow:

a. Leaching out

(1) Dip impregnated suit in water (60°F) for 30 seconds. Hang up and allow to drip dry. This procedure may be considered as roughly equivalent to falling into a river or lake. The garments were weighed (dry) before and after the test to determine the amount of agent lost.

Retardant	Impregnate Wgt. Before, grams	Impregnate Lost, grams	Percent Lost
No. 1	85	62.8	74
	82	61.5	75
	80	56.8	71
	Average 82.3	60.4	73

Incl. #1

Retardant	- Continued -		Percent Lost
	Impregnate Wgt. Before, grams	Impregnate Lost, grams	
No. 2	76	36.8	48.3
	69	38.8	56.2
	64	37.9	59.2
	71	36.1	50.8
	Average 70	37.4	53.6

(2) Men wore suits during a march of 6 miles at 3 mph, with 20 pound pack. Temperature 100°F, Relative humidity 50%. No sunshine. Sweat loss rate 740 c.c./hr. Such conditions may be encountered in any hot southern climate on a cloudy day. The garments were weighed (dry) before and after use to determine the amount of impregnating material leached by sweat.

Retardant	Impregnate Wgt. Before, grams	Impregnate Lost, grams	Percent Lost
No. 1	61	36	59.0
	63	40	63.5
	61	38	62.3
	86	55	64.0
	Average 68	42	62.2
No. 2	101	49.8	38.6
	85	37	41.3
	88	51	53.0
	Average 91	44.2	45.9

(3) Men wore suits during a march of 6 miles at 3 mph with 20 pound pack. Temperature 90°F, relative humidity 95%. No sun. Sweat loss rate 1176 c.c./hr. The condition is as severe a jungle environment as will be encountered anywhere. The sweat loss is great. Again loss of impregnate by sweat was measured.

Retardant	Impregnate Wgt. Before, grams	Impregnate Lost, grams	Percent Lost
No. 1	68	42	61
	82	58	70.7
	79	22	27.8
	75	46	61.3
	Average 76	42	57.4
No. 2	50	53	108
	88	46	52.3
	86	53	61.6
	85	32	37.6
	Average 77	46	63.1

Incl. #1

(4) Walk 30 minutes in rain. Total precipitation during walk, 1/4 inch. Temperature 46°F.

Retardant	Impregnate Wgt. Before, grams	Impregnate Lost, grams	Percent Lost
No. 1	70	65	92.8
	65	50	79.5
	74	51	69.0
	63	50	77.0
	Average 68	54	79.6
No. 2	79	75	95.0
	73	75	102.0
	98	74	75.5
	Average 83	75	90.8

b. Measurements of heat load - Any garment imposes a certain additional heat load upon man working in a hot environment. In order to determine whether impregnation appreciably increases the heat load due to fatigue uniforms, men were subjected to a standard work procedure in a constant environment with both impregnated and unimpregnated garments. Heat load was measured in terms of sweat loss per hour of work. Climate: Temperature 100°F, 50% relative humidity.

Clothing	Sweat Loss
No. Suit	608 c.c./hr.
Fatigues (untreated)	771 c.c./hr.
Fatigues Impreg. No. 1	741 c.c./hr.
Fatigues Impreg. No. 2	656 c.c./hr.

Each value is the average of results obtained with 4 thoroughly acclimatized men. The same men performed identical work in each suit. The differences between the control and the two test suits are not significant.

c. Burning characteristics

(1) Normal and impregnated garments were cut into strips 2" x 3". Each was held in front of a 1" diameter hole through which was coming a stream of air (6.5 liters per minute) at 500°C. The air stream was heated in a metal coil. The outlet orifice was 3/8" in diameter. The air stream traveled free for 1/4" before impinging upon the burn target. Temperatures were measured by thermocouple at the face of the burn target. See Chart 1. Time was recorded as follows:

- (a) To produce charring on side away from heat.
- (b) To produce glow.
- (c) Duration of glow (after-glow) in room air with no additional heat.

encl. #1

(2) Results are presented below.

Charring time in Seconds

Retardant		
None	No. 1	No. 2
3.27	3.70	2.60
2.73	3.52	3.00
3.00	3.25	2.85
3.10	3.20	3.00

Glow time in Seconds

Retardant		
None	No. 1	No. 2
5.4	4.05	5.0
5.13	4.0	5.1
5.15	4.35	5.1
4.97	4.32	5.25

Duration of glow (after glow) in seconds;  
heat source removed

Retardant		
None	No. 1	No. 2
Until all of cloth was de- stroyed, about 4 minutes	66	5.0
	96	4.0
	54	4.0
	60	4.5

Remaining protection after 60% impregnate leached  
out by sweat; time in seconds

Retardant			
No. 1		No. 2	
<u>Glow Time</u>	<u>Duration Glow</u>	<u>Glow Time</u>	<u>Duration Glow</u>
3.8	120	5.4	5.0
3.4	180	5.1	4.6

Remaining protection after 95% leached  
out; time in seconds

Retardant			
No. 1		No. 2	
<u>Glow Time</u>	<u>Duration Glow</u>	<u>Glow Time</u>	<u>Duration Glow</u>
4.1	252	4.7	3.0
3.9	Cloth destroyed	4.9	5.0
3.9	Cloth destroyed	5.0	4.0

Incl. #1

Relation between quantity of Retardant No. 2 in fabric and protective effect

	Wgt. Cloth Before	After	Diff.	% Impreg. in Cloth	Seconds		
					Char. Time	Glow Time	Duration After Glow
1.	1.600 gm	2.090 gm	.510 gm	24.4%	No Data	6.2 Sec.	1.0 Sec.
2.	1.558	1.990	.432	21.7	3.0 Sec.	7.1	1.0
3.	1.522	1.816	.294	16.2	2.0	5.4	2.0
4.	1.535	1.768	.233	13.2	1.5	4.4	1.6
5.	1.522	1.706	.184	10.8	2.0	4.6	2.0
6.	1.524	1.641	.117	7.1	1.8	4.5	2.5
7.	1.566	1.627	.061	3.7	2.0	4.9	2.0
8.	1.602	1.616	.064	3.8	2.1	4.5	1.8
9.	1.434	1.455	.021	1.4	2.2	5.0	1.5
10.	1.467	1.486	.019	1.3	2.4	5.5	1.5
11.	1.354	1.359	.005	.4	2.2	5.0	1.9
12.	1.327	1.331	.004	.3	2.2	5.1	1.5
13.	1.2550	1.2565	.0015	.12	2.4	4.8	1.6
14.	1.2121	1.2134	.0013	.11	2.2	5.7	1.6
15.	1.3446	1.3451	.0005	.04-	2.6	6.0	Incinerated
16.	1.3221	1.3225	.0004	.03	2.8	5.6	Incinerated
17.	Control	(no impreg.)		0.00	3.0	5.0	Incinerated
18.	Control	(no impreg.)		0.00	2.8	5.1	Incinerated
Average T. 510° C					Air 6.5 L/min.		

Only one-tenth of one percent (0.1%) of retardant No. 2 by weight is needed in the garment to produce the desired effect (Stop after-glow). Garments originally impregnated by the above described field technique contain approximately 5% by weight. After losing 60% of the impregnate as result of leaching by either rain or sweat, the garment still contains 2% by weight, more than adequate protection. Even after losing 95% of the retardant when washed for 20 minutes in cold water without soap, the garment still contains approximately 0.25% and is protective. Therefore, the margin of safety after a single impregnation is relatively great, though protection is only temporary. Repeated wetting, washing in cold water with soap or in a G.I. laundry will remove all of the impregnating agent.

d. Protection against burns.

(1) Impregnated and non-impregnated cloth were placed on the forearm and the length of time was recorded to produce a definite burn by a hot air stream. (Temperature - 500°C, Air flow 6.5 L/min.)

Incl. #1

No Covering		Untreated Fabric	Fabric treated with Retardant No. 2
0.25 Sec. 2nd Degree burn 1.0 Cm diameter	Dry	2.5 Sec. 2nd Degree burn 0.8 Cm diameter	2.1 Sec. 2nd Degree burn 1.2 Cm diameter
	Wet	2.9 Sec. 1st Degree scald 4.0 Cm diameter 2.6 Sec. 1st Degree scald 2.0 Cm diameter	2.6 Sec. 1st Degree scald 5.5 Cm in diameter

e. Comfort and skin irritation.

(1) Suits were worn by eight men for three weeks outside in winter: cold (25°F), in wet cold rainy weather (46°F) by eight men for one day, in a simulated hot southern climate (100°F, relative humidity 50%, with and without simulated sun) by eight men for three days, and under simulated severe jungle conditions (90°F, relative humidity 95%) by eight men for three days). No discomfort was noted. There was no apparent change in the texture of the cloth. No skin reactions occurred (men wore nothing under these garments during skin tests). Patch tests were done on fifty (50) men with each agent (5% of patch by weight was impregnated; patches consisted of squares of impregnated cloth 1/2" x 1/2" applied to the arm by adhesive with an intervening layer of cellophane. Area examined at 24 and 48 hours). No reactions were seen.

f. Durability of impregnated clothing.

The impregnated garments were worn by men on regular duty for two weeks and showed no apparent weakness due to impregnation. This does not represent an adequate test. See footnote of report, page 2. This office is informed that the O.Q.M.G. is doing extended wear and tear tests.

5. Summary of results:

a. Dipping suits in water or wading through streams can be expected to leach out sufficient quantities of No. 1 (Flame-out - Treadale) to make it ineffective. The same procedure with suits impregnated with No. 2 (Fire Retardant CM - Dupont) causes from 45% to 70% leaching, but not enough to lose effectiveness.

b. Similar results are produced by heavy sweating (1000 c.c. per hour) and by soaking in moderate rain.

c. The heat load imposed by the garment is not significantly increased by impregnation with either agent if the impregnate does not exceed 7% of the total weight of the garment.

*Handwritten signature or initials*

d. The burning characteristics of the cloth while in contact with a heat source are not appreciably altered by the treatment nor does the treatment increase the protection as compared with that afforded by the untreated garment against skin burns from hot air while in contact with the heat source.

e. "Fire Retardant CM" Dupont stops flame and after-glow as soon as the heat source is removed and thereby affords very real protection against additional burns from fire spreading through the garment.

f. Impregnation in the field is practical and valuable as an expediency and temporary measure. Twenty-five pounds of "Fire Retardant CM" Dupont in 25 gallons of water will impregnate approximately 100 fatigue uniforms.

g. The texture and comfort of the suit are not appreciably altered by the treatment and skin reactions are not to be expected.

h. A more permanent impregnating procedure is desirable, and additional studies of the effects of impregnation upon the life of the fabric are needed.

## APPENDIX B

Instructions for impregnating clothing with "Fire Retardant CM".

1. "Fire Retardant CM" is a chemical agent which will stop fires and afterglow in clothing.
2. Its action is only temporary because it is rapidly removed by repeated wetting or washing.
3. Because of its temporary effectiveness and because it may shorten the life of garments, it should be used only where men are going into action and only for those exposed to fire hazards; particularly:
  - a. Tank crews
  - b. Personnel handling or using incendiary agents including flame throwers
  - c. Personnel handling gasoline and ammunition (1st echelon supply)
  - d. Other personnel designated by unit commanders because of exposure to fire hazards
4. To impregnate clothing with this agent, dissolve twenty-five pounds (25 lbs.) of "Fire Retardant CM" in twenty-five gallons (25 gal) of water in container, 33 gallon; galvanized iron. Soak garments in this solution for 20 minutes (Note: If uniforms are new and unlaundered, 40 minutes will be required to assure saturation). Wring by hand (do not use mechanical wringer) and hang on line to dry. This solution will impregnate approximately one hundred (100) suits, two piece (or one piece) herringbone twill or equivalent. Not more than six (6) suits are to be placed in the solution at any one time.\*
5. Re-impregnation is required every time clothing is washed.

---

\* Where small units are widely dispersed, issue on an individual basis may be considered. One quarter pound (1/4 lb) in two quarts of water will impregnate one suit. Procedure is the same except that suits are not to be wrung out.

Incl. # 2

CHART I  
SCHEMATIC DRAWING OF BURNING APPARATUS

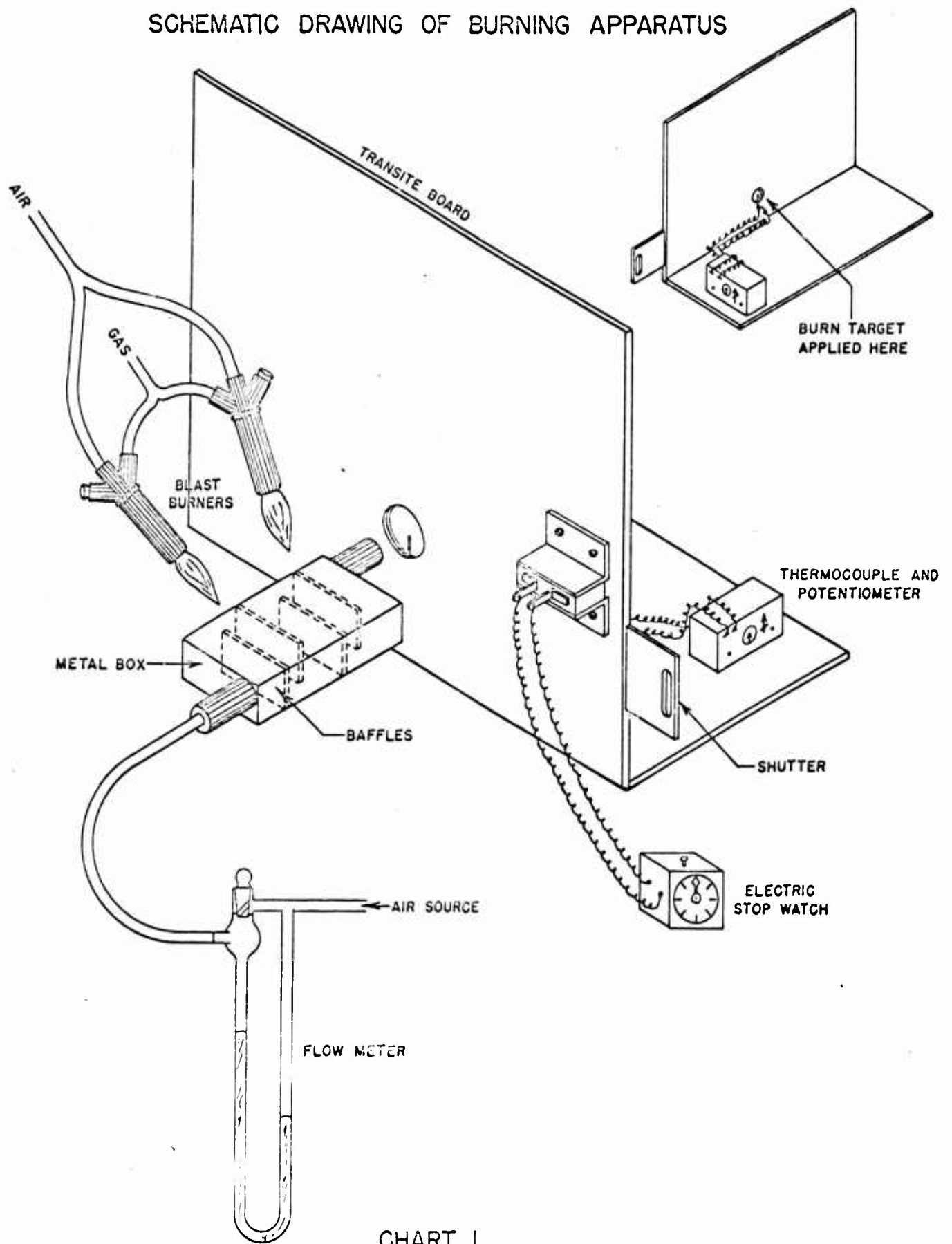

CHART I