

ARMORED MEDICAL RESEARCH LABORATORY  
Fort Knox, Kentucky

DDC  
RECEIVED  
SEP 28 1967  
RECEIVED

Project AMRL No. 37, NDRC SOS-11  
SPMEA 413.74-4

28 March 1945

FOURTH PARTIAL REPORT  
STUDY OF ERRORS IN FIELD ARTILLERY PRACTICE

1. PROJECT: No. 37 - Study of Errors in Field Artillery Practice, Fourth Partial Report; Subject; An Analysis of the Sources of Error in the Use of the Aiming Circle and Development of an Improved Instrument.

a. Authority: Letter AGF, 413.68 (R) (8 Apr 1944) GNRQT-10/78261 dated 8 April 1944.

b. Purpose: (1) To determine the principal causes of error in reading horizontal angles with the standard M1 aiming circle; and (2) to develop basic improvements in principles of design which will eliminate such sources of error and to incorporate these in a practical field instrument.

2. DISCUSSION:

a. In the First Partial Report of this study (18 September 1944) frequency of errors at the battery contributed by the executive were reported to be as high as 20 per cent. Presumably, these were mainly errors in reciprocal laying, contributed for the most part by mistakes in reading the aiming circle. Similarly, errors in the use of the aiming circle account for many incorrect surveys. Further evidence of weakness in this instrument is seen in the results of tests at the Field Artillery School. Approximately sixteen (15.7) per cent of a series of angle measurements made with the aiming circle, M1, by 110 student officers were in error by more than three (3) mils.

b. A proposed new design of aiming circle is presented in Appendix I, and the comparative results of field tests with the present MI instrument and the German aiming circle, which possess to some degree the proposed design features, are summarized in Appendix II.

3. CONCLUSIONS:

a. Analysis of present form of aiming circle, MI, employed for measuring angles and laying the battery indicates that it is basically similar to the panoramic sight with respect to design of scales and possesses the same inherent weaknesses from the standpoint of potential error in use.

b. The major deficiencies of the azimuth scale of the present instruments are:

AD 658589

- (1) Use of two separated coarse and fine scales, displaced in a direction opposite to the order of reading the whole azimuth value.
- (2) Continuous movement of the coarse scale relative to its index with rotation of the micrometer, resulting in uncertainty and confusion concerning the true hundreds scale value when the micrometer reading is in the danger zone just below 100 or above zero.
- (3) Inadequacies of design and numbering of both coarse and micrometer scales, requiring frequent interpolation in unnumbered portions.
- (4) Lack of sufficient definition and clarity of engraved lines and numbers on the scales.

c. Comparative tests conducted with the aiming circle, M1 and a German aiming circle (R. K. 12m beh 1025 KF), indicated clearly the advantages offered by an in-telescope, direct reading instrument from the standpoint of relative certainty of reading and easier understanding of how to use the instrument. A proposed new instrument, employing this principle of operation and other improvements has been designed.

4. RECOMMENDATIONS:

That an in-telescope, direct reading aiming circle, of the type presented in Appendix I, be developed and sufficient pilot models be constructed for field test.

5. ACKNOWLEDGEMENT:

This project is a joint undertaking with MDRC and the field tests reported herein were jointly conducted with the staff of MDRC, Project SOS-11, Dr. John P. Nafe, Director.

Submitted by:

Theodore P. Hatch, Lt. Col., SnC  
 Frederick S. Brackett, Lt. Col., SnC  
 Steven M. Horvath, Captain, SnC

3 Incls.  
 #1 - Appendix I  
 #2 - Appendix II  
 #3 - Figures 1 - 9

APPROVED

*Willard Machle*  
 WILLARD MACHLE  
 Colonel, Medical Corps  
 Commanding

## APPENDIX I

### PROPOSED AIMING CIRCLE DESIGN

1. With respect to design and placement of azimuth scales and likelihood of error in reading the scales or in setting off desired angles, the aiming circle, M1 (Fig. 1) is similar to the panoramic telescope M12 in that it has the same basic deficiencies. Evidence of this is seen in the reported errors which occur in its use (First Partial Report, 18 September 1944) together with the additional experience presented herewith (Appendix II). The instrument has certain other features not found in the panoramic sight which increase the likelihood of error, notably, the presence of the plateau and drum scales adjacent to the main azimuth scales which add unnecessary confusion and the multiplicity of knobs for the upper and lower motions which are not readily distinguished from each other. Since the aiming circle is a primary instrument, employed in initial laying of batteries and even in surveying, it is especially desirable that its operation be free from error and, at the same time, that it be capable of use with speed and dispatch. The battery executive has so many responsibilities that he should be relieved, so far as possible, of worry with respect to potential errors in the use of his aiming circle.

a. Owing to the placement of rotation knobs and other basic design features of the present instrument, the principle of the spiral micrometer disc bearing on the coarse scale, recommended for the panoramic telescope (See Second Partial Report, 22 March 1945), is not readily applicable to the aiming circle as a means of improving scale design and reducing the likelihood of errors. Moreover, since the instrument is employed primarily for measuring horizontal angles and in view of the speed desired, the use of external scales may not give the most desirable arrangement. It is believed that definite advantages are gained from the use of internal scales which are read directly in the telescope field. The speed of operation is increased, but more important, the operator has a visual picture of the relationship between the target and the azimuth scales. The scale design must, of course, possess the necessary attributes for insuring the maximum certainty of reading. In the proposed new instrument, described below, a portion of the continuous azimuth scale, graduated in mils, is projected into the telescope field and is seen as a reticle upon which the target is superimposed, as in Fig. 3. The scale is numbered every 10th mil and one reads the position of the target along the 10 mil section much as one reads a foot-rule. In Fig. 3, for example, the reading is 1573 mil. The technic of reading, it will be noted, is one with which practically everybody is familiar. Experience with a somewhat similar instrument (Appendix II) shows that an understanding of the reading procedure is readily acquired with minimum training and that, compared with aiming circle, M1, the frequency of errors in reading, is markedly reduced.

#### b. Description of Instrument.

- (1) Measurement of Horizontal Angles. The proposed instrument represents a complete departure from the basic design of the

Mil aiming circle, as shown in Fig. 2. In place of the accurate gear and micrometer worm for angle measurement, the proposed instrument makes use of a direct scale graduated at 1 mil intervals on a glass ring (A) mounted concentrically in the base. A 100 mil portion of this scale, which is numbered every 10 mil, is projected optically into the telescope field where it is seen as a section of a graduated "measuring stick" on which any targets in the field are superimposed. The magnification of the mil scale in projection is such that the angle subtended at the eye is the same as that in the telescope field. To measure the angle to a target it is only necessary to bring it into the telescope field and read its position on the graduated mil scale (Fig. 3). Thus, it is not necessary to adjust the target exactly to a vertical cross-hair with consequent saving in the time required to complete the angle measurement. Furthermore, all targets appearing simultaneously in the telescope field can be measured without rotating the instrument.

The dimensions of the mil scale graduation approximate those of a good reticle and therefore no unusual difficulties are presented in the construction of the scale. Accuracy of the instrument depends upon uniformity of etching of the scale and correct centering in the instrument. A rack mechanism (B) and gear and worm (C) are provided but only for the purpose of fine adjustment in the upper and lower motions, respectively.

- (2) Compass Setting. The compass needle (D) is viewed through a window (E) in the instrument housing for rough setting, but for accurate adjustment it is viewed through the telescope where its magnified image is seen in relation to the mil scale. To orient the instrument on the North line, the lower slow motion is adjusted until the compass needle is seen to coincide with the declination constant on the mil scale, as shown in Fig 4. (Declination constant, 6257). As an alternative, the telescope may be first adjusted by the upper motion to bring the vertical cross-hair into coincidence with the declination constant and the compass needle then adjusted, by lower motion, to the vertical line as a reference point.
- (3) Measurement of Vertical Angles. Changes in vertical line of sighting are accomplished by rotation of the prism (F) without altering the position of the telescope eyepiece. The vertical range of the instrument is from -300 to + 700 mil. A spiral-edge micrometer dial in conjunction with the hundreds scale is employed to indicate the vertical angle. This feature, together with the alternate numbering of the micrometer values on the large diameter dial, minimizes the likelihood of 100 mil errors or errors caused by the necessity for interpolation on sparsely numbered scales (See Second Partial Report, 22 March 1945).

- (4) Telescope. Two forms of telescopes are shown (Figs. 2 and 5), one centrally mounted with a vertical eyepiece and the other with its eyepieces set at  $45^{\circ}$ . Both forms have the advantage of more comfortable viewing position, as compared with the horizontal arrangement in the M1 aiming circle and the vertical instrument has the added advantage that the eyepiece remains in one position when the instrument is rotated, making it unnecessary for the operator to follow the telescope around in the initial adjustment. The second design has the advantages of less overall height and a simpler optical system. In both telescopes, the magnification is  $4\times$  and an apparent field  $70^{\circ}$  is obtained by use of Erfle type eyepieces.
- (5) Structural Features. Provisions are made for rapid upper rotation by means of a rack and a clamp provides for throwing out the lower motion. Three-point leveling of the instrument on its base is provided together with the necessary circular and two cross-leveling vials. A new feature is the combination tripod and carrying case. This device (Fig. 6) has the necessary features of sturdiness and adjustability required of the tripod and, when folded back over the instrument, it forms an enclosure for carrying, thus eliminating the separate carrying case. The combination is proposed for consideration as a convenient and weight-saving measure.

No means of illumination is shown in the design but no difficulty should arise in applying suitable lighting devices to the mil scale and to the telescope.

## APPENDIX II

### FIELD TESTS

1. A partial measure of the degree of improvement in relative certainty of correct reading of horizontal angles which may be expected with the proposed new aiming circle over the M1 was obtained in comparative tests with the German aiming circle, R.K. 12w beh 1025 KF. This latter instrument (Fig. 1) does not provide for the single scale reading which is found in the proposed design. Angles are read directly in the telescope field, however, with a reticle provided for this purpose. The findings may therefore be considered indicative of the improvement which may be expected from the proposed instrument. Horizontal angles are measured with the German instrument in the following manner: having no micrometer rotation in its upper motion, it is pointed toward the target to the nearest even hundred mil value, greater or smaller as the case may be, where it is held by a positive detent. The target is then seen in the telescope field superimposed on a reticle, graduated to  $\frac{1}{2}$  mil and numbered from 40 mil on the extreme left to 100 - 0 at the center of the field and extending to 60 mil on the right. The reticle scale is numbered every 10 mil as shown in Fig. 7. The two adjacent 100 mil values for the particular setting of the instrument are projected optically from the coarse scale into the telescope field and viewed in the manner shown in Fig. 7. Thus the total value of the angle can be read directly in the field by combining the proper hundreds value with the reticle reading of the target position. If the target is on the left of the vertical cross-hair (100 - 0) the left-hand hundreds value is taken and similarly for a target position to the right, one reads the corresponding hundreds value. Opportunity for misreading by 100 mil has not been eliminated but the probability of occurrence has been reduced, owing to the positional relationship between the target on the reticle and the corresponding hundreds value, which is quickly learned. Of greatest interest in the present study, however, was the fact that this instrument provides for direct reading of the angle within the telescope in a manner similar to that provided in the proposed new instrument.

#### 2. Field Tests with American\* and German Aiming Circles.

a. Test Procedures. Determination of the relative number of errors in a series of angle measurements with the two instruments was made at Fort Knox and the Field Artillery School, Fort Sill. The tests at Fort Knox consisted in the measurement of sixteen angles varying in magnitude from less than 100 mils to over 3000 mils. Approximately half of the angles were in the micrometer danger zone of 85 to 10 mils. The stakes for these angles were placed along a full circle approximately 200 yards from the aiming circles. A new zero point was designated for each angle measured, thus requiring considerable mechanical manipulation of the instruments in the test. For these measurements a total of 17 subjects from the 414th Field Artillery Battalion were employed. These men had had a moderate amount of experience with the M1 aiming circle, and were given only limited instruction in the use of the German instrument. The subjects were rotated in a random manner

\* Plateau scale removed

in use of the two instruments.

b. The tests at the Field Artillery School consisted in the measurement of a series of twenty horizontal angles, varying in magnitude from 100 mils up to 3100 mils and well distributed so as to avoid an undue weighting with respect to position on the coarse and fine scales. The two aiming circles were spaced about 30 yards apart. A series of twenty-one stakes were located along a semi-circle of approximately 100 yards radius and carefully positioned by an aiming circle at the first point to give a predetermined series of twenty angles from the zero stake. The angles from the second point did not differ markedly in value from this pre-selected group. Each man measured the twenty angles with each of the two instruments. For these measurements a total of 43 test subjects drawn from School Troops were employed. They included nineteen (19) officers and twenty-four (24) enlisted men from survey sections of the School. These men had had from six to thirty-six months training in survey, although about one-fourth had not been actively engaged in survey work for about two months. Each group of eight (8) or sixteen (16) men was divided into two sub-groups. At the outset of each test period the two sub-groups were assigned to the two aiming circles and remained at their assigned positions until all men had measured the twenty angles, after which the groups shifted. The order of reading the angles was suitably altered from one aiming circle to the other so as to equalize as much as possible all variables not under study. Only minimum instruction was given to the men on the method of operation of the German aiming circle. The maximum period for any group was eight minutes, approximately one-half minute per man. This time was devoted primarily to instruction in the reading of the scale, especially the reading of the hundred mil values in relation to the position of the target in the visual field of the telescope.

c. Results of Tests.

- (1) Relatively inexperienced men. The comparative results of tests with seventeen (17) men from the 414th Field Artillery Battalion, having only a moderate amount of experience with aiming circles, are presented in Table 1. Considering the errors from all sources and all magnitudes, the per cent of errors for the American aiming circle was approximately 40%, of which 8.5% were in the nature of mistakes in reading greater than  $\pm 3 \mu$ \*. Analysis of the errors in respect to source brings out clearly the deficiencies in scale design (see similar breakdown for the panoramic telescope M12 in the Second Partial Report, 22 March 1945). The errors less than 100 mils in magnitude are directly traceable to the confusion arising out of the necessity for constant interpolation along the sparsely numbered micrometer scale of the M1 aiming circle together with the fact that only a limited portion of the scale is visible at a time. Despite the lack of familiarity with the German aiming circle, 69.5 per cent of the angles were measured correctly by the test group, ten per cent more than with the

\* All errors of  $\pm 3 \mu$  and less have been arbitrarily called instrumental errors to distinguish them from mistakes in scale reading, in spite of the fact that some of the small errors were undoubtedly true mistakes.

TABLE 1

## SUMMARY OF ERRORS IN ANGLE MEASUREMENT BY AMERICAN AND GERMAN AIMING CIRCLES

S. P. ARTILLERY TROOPS - FORT KNOX

Micro. Value of Angle	AMERICAN A. C.			GERMAN A. C.		
	80-10	10-80	Total	80-10	10-80	Total
Number of Angles	7	9	16	8	8	16
I. No. Correct Meas.	68(57)*	94(61)	162(60)	94(69)	95(70)	189(70)
II. No. of Instr. Errors	39(33)	48(31)	87(32)	36(27)	31(23)	67(24)
± 1' ✓	35	44	79	25	18	43
± 2' ✓	3	4	7	7	9	16
± 3' ✓	1	-	1	4	4	8
III. Mistakes	11(9)	12(8)	23(8.5)	6(4)	10(7)	16(6)
Read wrong side major grad.	3	1	4	-	-	-
Read nearest major grad.	2	4	6	-	-	-
100' or more	6	5	11	2	4	6
Transp. of Figures	-	1	1	2	3	5
Failure to lock Instr.	-	-	-	2	2	4
Record reverse Angle	-	1	1	-	-	-
Unexplained	-	-	-	-	1	1
Total Readings	118	154	272	136	136	272

\* Percentage values in ( )

American instrument, with which they were familiar. The number of mistakes was also smaller and these arose from entirely different causes than did the incorrect readings with the American aiming circle. Four of the mistakes were from mechanical causes. Two of the three transposition errors resulted from failure to include the zero in a statement of size of angle; viz., calling out 13 instead of 103. The six 100 mil errors (four were made by a single individual) are chargeable to lack of understanding of the principle of the German instrument, the larger of the two figures seen in the lower field being read regardless of the position of the target on the reticle. This indicates a basic defect of the system which allows a choice of values, a weakness which has been avoided in the proposed new instrument.

- (2) The greater number of errors 100 mils or more in magnitude observed with the M1 (11 against 6) arose from the well-known cause, namely the displaced coarse and fine scales and uncertainty of relation between the two. Six of these errors occurred in the reading of seven angles having micrometer values from 80 - 100 and 0 - 10  $\mu$  and the other 5 in the reading of the remaining 9 angles. Another point of considerable interest is the failure of any of the subjects to make errors greater than 100  $\mu$  with the German instrument whereas three subjects made such errors (up to 800 mils) with the M1.
- (3) Experienced Men. Nineteen (19) officers and twenty-four (24) enlisted men from School Troops at Fort Sill, who had had considerable experience in survey and in use of the American aiming circle, took part in the next group of tests. The time to read and report the twenty angles was measured. Despite their unfamiliarity with the German aiming circle, the average time required for the twenty angles was a half minute less than for the corresponding angles measured with the American instrument — 6 minutes, compared with 6½ minutes.
  - (a) The greater certainty of reading angles correctly when the value is obtained directly from a scale in the telescope itself is strikingly demonstrated by the results of this test. Over 78 per cent of angles were measured correctly with the German instrument in contrast to only 40 per cent, in the case of the M1 aiming circle. Furthermore, only two mistakes, both questionable in nature, were recorded with the German aiming circle as compared with 63 mistakes in the use of the American instrument. One of the two was of a type which can never be entirely eliminated: The correct angle of 1819  $\mu$  was reported as 1919, despite the fact that the figure 19 did not appear in the visual field, the double set of figures being (17.18). The other, 30  $\mu$  in magnitude, resulted from failure to seat the instrument properly in detent, and did not involve an error in scale reading.

TABLE 2

## SUMMARY OF ERRORS IN ANGLE MEASUREMENTS BY AMERICAN AND GERMAN AIMING CIRCLES

F. A. SCHOOL TROOPS - FORT SILL

Micro Value of Angle	AMERICAN A. C.			GERMAN A. C.		
	80-10	10-80	Total	80-10	10-80	Total
Number of Angles	7	13	20	7	13	20
I. No. of Correct Meas.	103(37)*	232(40)	335(39)	217(78)	456(78)	673(78)
II. No. of Instr. Errors	150(54)	312(53)	462(54)	60(22)	125(22)	185(22)
± 1'	97	206	303	48	104	152
± 2'	41	75	116	10	21	31
± 3'	12	31	43	2	-	2
III. Mistakes	24(8.7)	39(6.7)	63(7.3)	-	2(0.5)	2(0.25)
± 4'	1	1	2	-	-	-
± 5'	14	26	40	-	-	-
± 10'	2	3	5	-	-	-
± 20'	2	1	3	-	-	-
± 33'	-	1	1	-	-	-
± 35'	-	1	1	-	1	1
± 100'	3	2	5	-	1	1
± 200'	2	4	6	-	-	-
Total readings	277	583	860	277	583	860

\* Percentage values in ( )

- (b) Not only did the men read a greater proportion of the angles correctly with the unfamiliar German instrument but more than 94 per cent of the angles were read to  $\pm 1$  mil of the correct angle in contrast to less than three-quarters of the measurements of equal accuracy made with the American instrument. In this group, as with the inexperienced group, no errors in excess of 100 mils were made with the German aiming circle, whereas six (6) were made with the M1.
- (c) The comparative results of these tests are so striking as to leave little doubt of the improved performance, from the standpoint of frequency of errors, to be expected from the proposed instrument. Moreover, the experience shows clearly that little difficulty may be expected in training men in the correct use of the instrument.

### 3. Other Features of German Aiming Circle

a. The German aiming circle possesses certain other features of design which indicate that in the development of the instrument, the required functional characteristics have been studied and an attempt made to provide for them more successfully than in past designs. This is of particular interest in view of the fact that the instrument which it replaced was very similar to the present U. S. standard M1. Of interest, from the standpoint of reduction of errors, is its special provision for reciprocal laying of the battery. A secondary projecting system is provided parallel to and below the sighting telescope (Fig. 1) which includes a reticle carrying the vertically repeating and evenly spaced markings shown in Fig. 8. The reticle of the German panoramic sight Rbl F 32 has a single line of corresponding symbols (Fig. 9). When the aiming circle telescope is directed toward the gun sight to the nearest 100  $\mu$  and the gun sight similarly directed toward the aiming circle, one of the symbols or a line and portions of the two adjacent symbols on the aiming circle reticle can be seen through the panoramic sight. The particular symbol which is seen depends upon the angle of offset between the line of sighting of the aiming circle telescope and the true line from the panoramic sight to the aiming circle. The procedure in reciprocal laying is simplified as compared with that required with the American instrument. Thus, the executive rotates his instrument from the 0-3200 line toward the gun sight and fixes it at the nearest hundreds value. He calls off to the gunner only the right-hand whole hundreds value as read in the telescope. The gunner sets this hundreds value on his panoramic sight and then traverses the gun until the corresponding symbol on his reticle is superimposed on the symbol seen in the projecting telescope of the aiming circle. The spacing of symbols (Fig. B) is equal to 2  $\mu$  and from any symbol to the adjacent line is 1  $\mu$ . Thus, if the true deflection of the gun sight from the 0-3200 line of the aiming circle is 1876, for example, the panoramic sight would be set at 1900 and the gun traversed until the symbol Z is superimposed on the corresponding symbol projected from the aiming circle. For deflection 0637, the reticle pattern to be matched would be:

$$4 \quad \left| \begin{array}{l} (4 = 36 \mu) \\ (38 \mu) \end{array} \right.$$

with the panoramic sight set at 0600. In both cases the gun would then be parallel to the 0-3200 line of the latter instrument. Certain advantages are

immediately suggested by this procedure; first, the command from the executive to the gunner is simplified since the deflection is given as a whole hundreds value only, thereby reducing the probability of errors in communication and execution of command; secondly, no secondary error arises from sight displacement when the gun is traversed to bring the panoramic sight into line with the aiming circle. This latter error, although generally small (1 to 3 m) is a common source of annoyance with the U. S. aiming circle and is eliminated only by checking and relaying. There are certain obvious disadvantages, foremost of which is that the instrument must remain pointed toward a particular gun until the gunner has completed his laying, whereas with the American aiming circle the executive can pass to the second gun while No. 1 is laying, etc., returning to No. 1 for re-check after measuring the angle to No. 4\*. Another is that there is no check on correctness of the laying of a particular piece as there is with the American technic which involves an exchange of instrument readings, although there is nothing to prevent such check readings being made.

b. The facilities for reading angle of site in the German instrument are not improved over earlier designs with respect to certainty of scale reading. It will be noted, on the contrary, in the proposed new aiming circle the spiral disc principle has been employed on the angle of site scales to minimize errors of reading.

\* It is of interest, however, that in some limited tests, it was found that the speed of laying the battery with the German instrument was the greater despite this.



AIMING CIRCLES  
AMERICAN M1 (LEFT) AND GERMAN (RIGHT)  
ARMORED MEDICAL RESEARCH LABORATORY  
FORT KNOX, KY.

Project No. 37

Figure 1

*Incl # 3*

FIG. 7  
TELESCOPE FIELD OF GERMAN AIMING CIRCLE  
SHOWING ADJACENT HUNDREDS VALUES AND  
RETICLE SCALE AND  
ILLUSTRATING TARGET READING

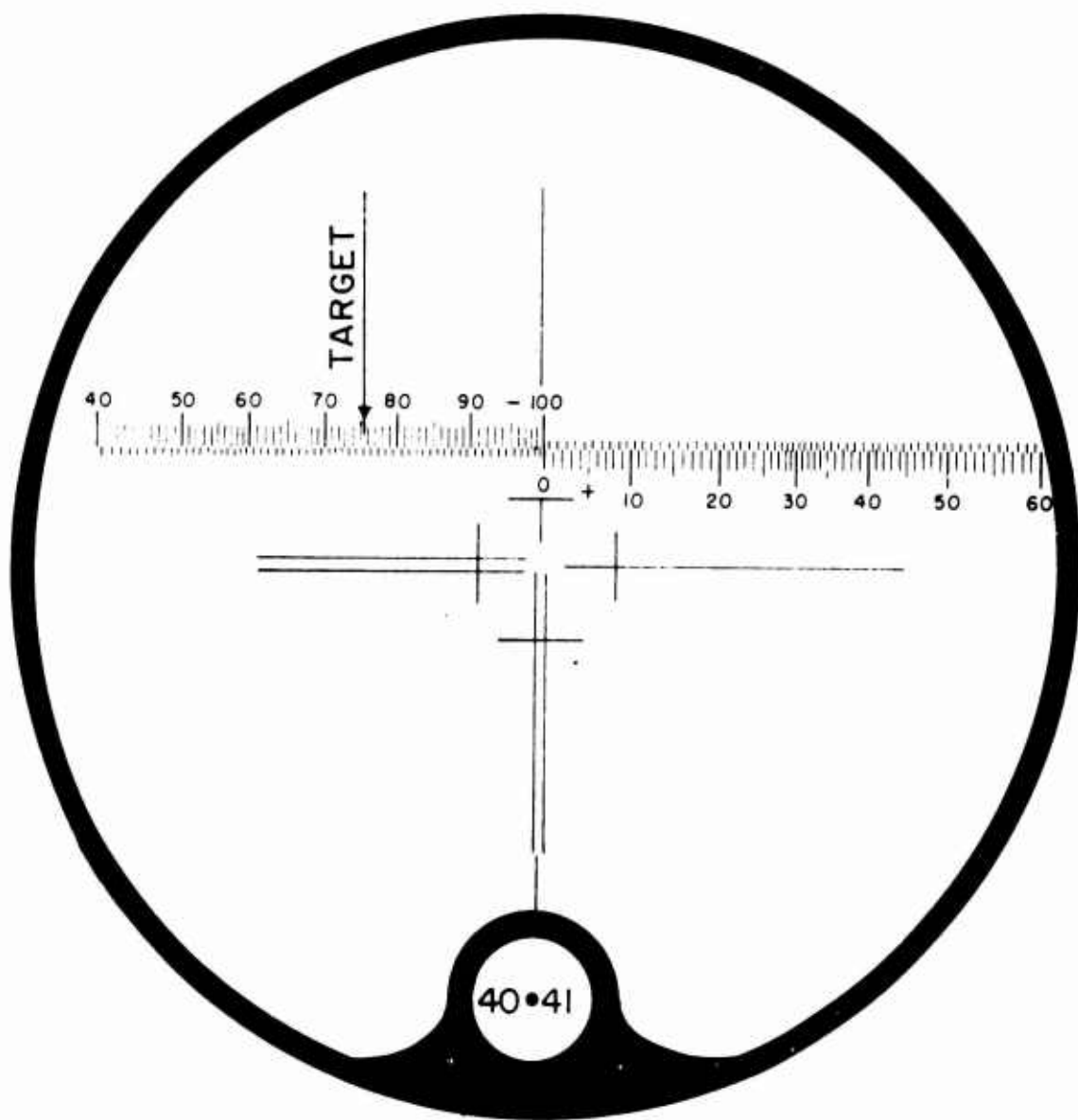

THIS IS THE  
**4075.5**  
READING

FIG. 7

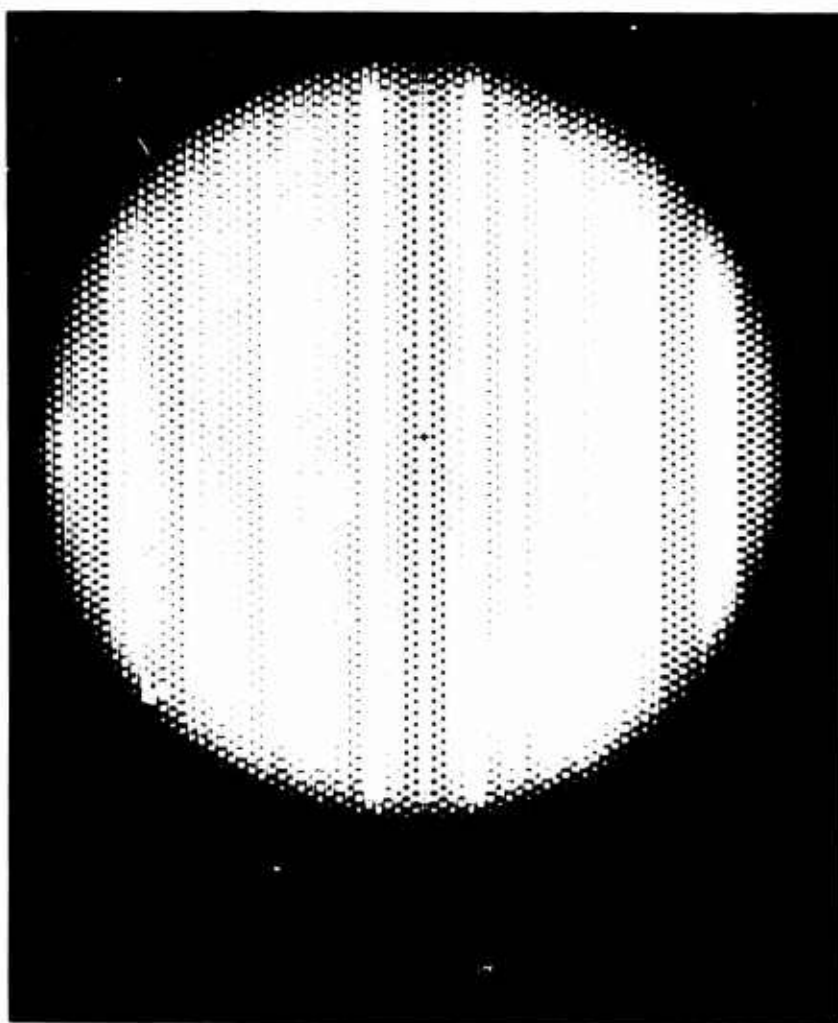

HYDRA PIPES IN PROJECTED VIEWS  
OF GENERAL ADHESION CIRCLES  
ARMORED MEDICAL RESEARCH LABORATORY  
FORT MONROE, VA

Project No. 37 Figure 8

Incl #3

RETICLE PATTERN OF GERMAN PANORAMIC TELESCOPE (RP1 F 32)

FIG 9

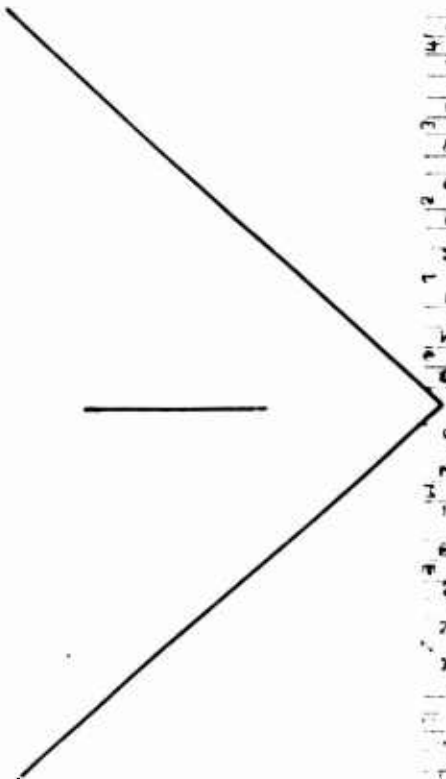

FIG. 9

NOTE THAT ON THIS HALF OF THE RETICLE  
THE 6, 9, 8 AND 2 HAVE A BAR THROUGH  
THE LARGEST OPEN SECTION

NOTE THAT ON PROJECTION FIELD ON THE AIMING CIRCLE  
THE SAME PATTERN IS PRESENT  
THE 6, 9, 8 AND 2 ARE DISTINGUISHED BY  $\diamond$  AND  $-$  AND  $-$  LINES

ENLARGEMENT OF FIGURES IN RETICLE

0 1 2 3 4 5 6 7 8 9  
A B C D E F G H I J K L M N O P Q R S T U V W X Y Z

ERRORS IN GUNNERY

- o 1. Project No. 21 (First Partial) 24 May 1944 - Determination of the Sources, Magnitude and Costs of Gunnery Errors. Hatch, Lawson and Dailey. *100f*
- o 2. Project No. 21 (Second Partial Report) 16 June 1944 - Determination of the Sources, Magnitude and Costs of Gunnery Errors. Hatch, Lawson and Dailey. *200 pages*
- o 3. Project No. 37, NDRC, SOS-11, 18 September 1944 - Study of Errors in Field Artillery Practice. Hatch and Horvath. *200 pages*
- o 4. Project No. 37 (Second Partial Report) 22 March 1945 - Study of Errors in Field Artillery Practice. Hatch, Brackett and Horvath. *100f*
- o 5. Project No. 37 (Third Partial) 6 April 1945 - Study of Errors in Field Artillery Practice. Hatch, Brackett and Horvath. *100f*
- o 6. Project No. 37 (Fourth Partial) 28 March 1945 - Study of Errors in Field Artillery Practice. Hatch, Brackett and Horvath. *100f*
- o 7. Project No. 37 (Final Report) 13 June 1945 - Study of Errors in Field Artillery Practice. Hatch, Brackett and Horvath. *100f*

A

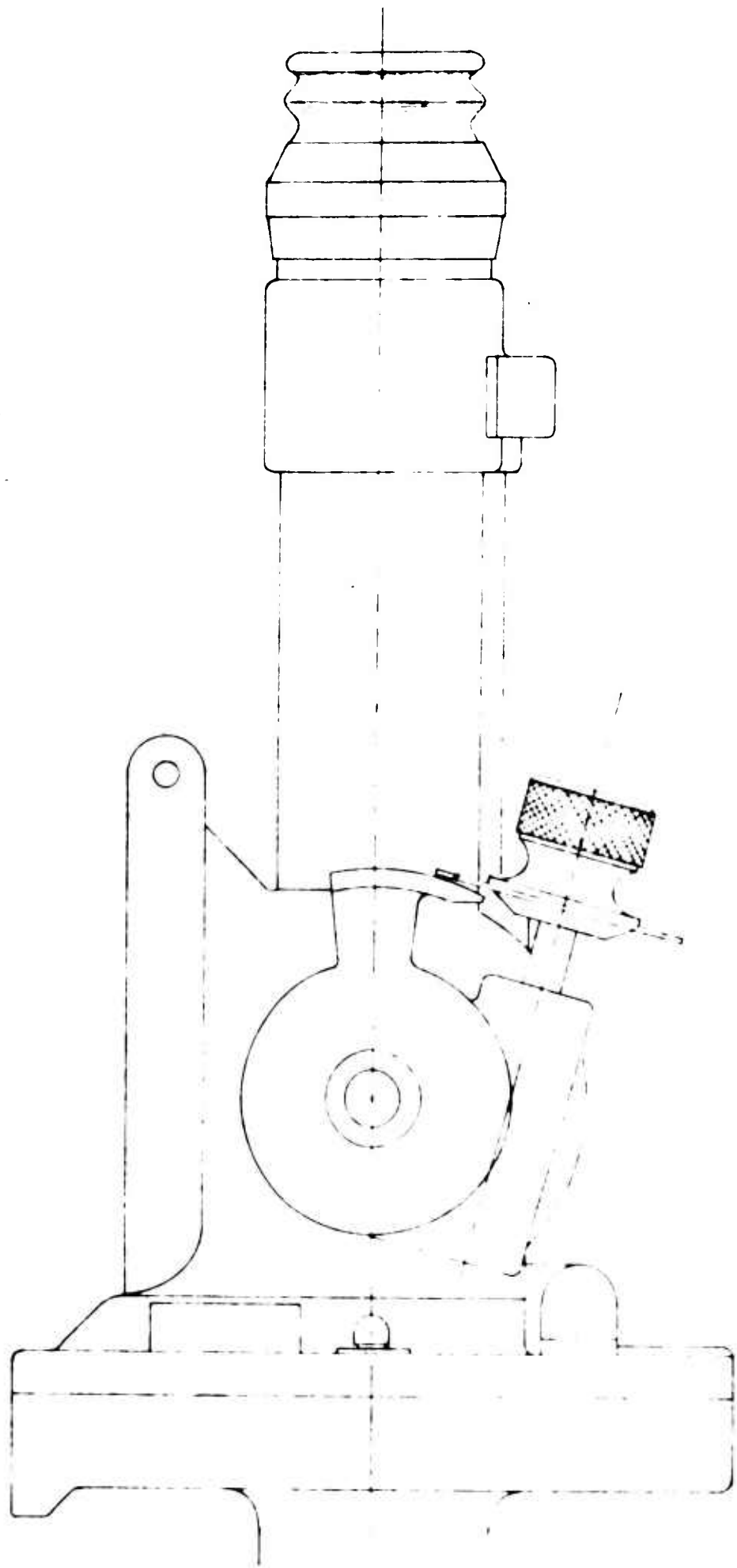

B

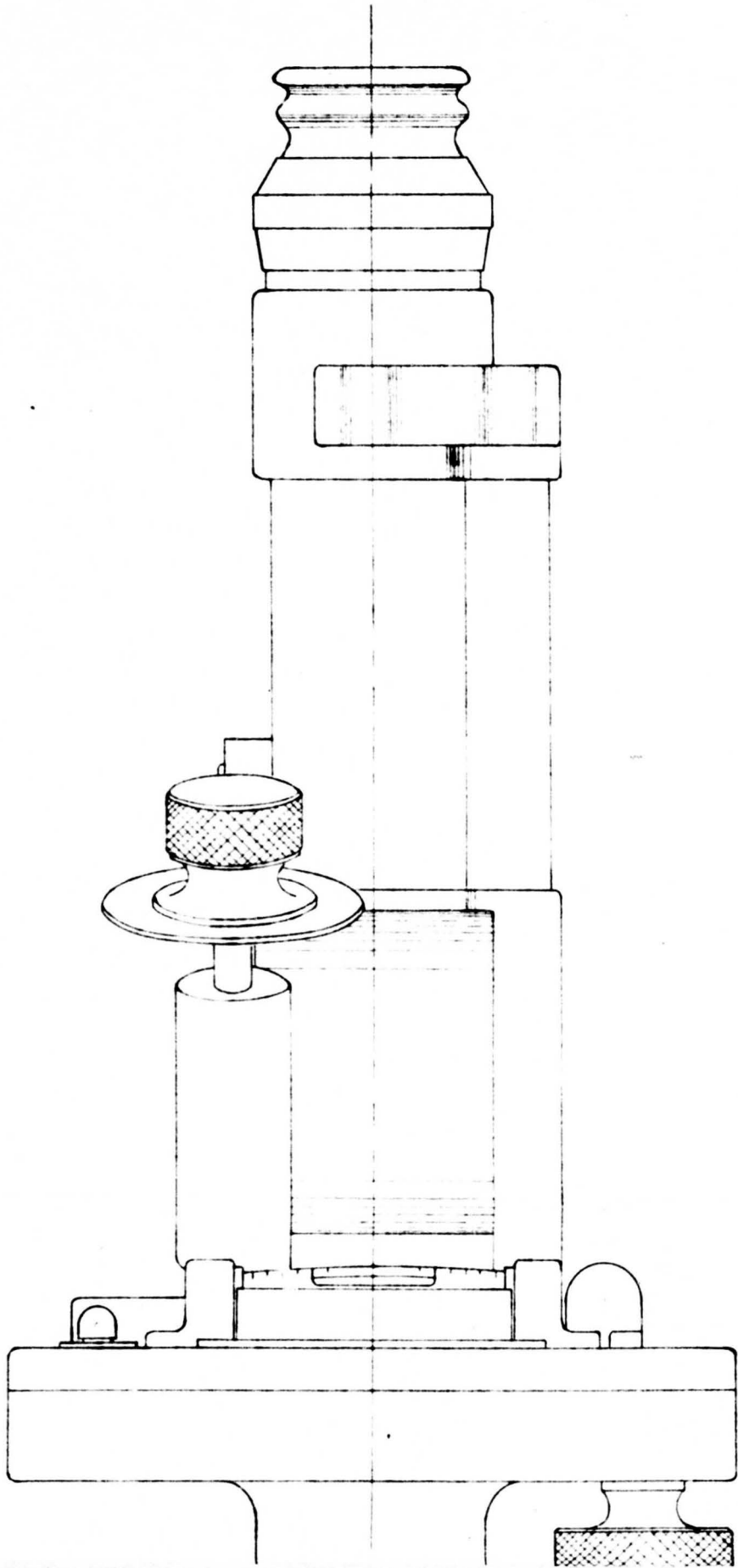

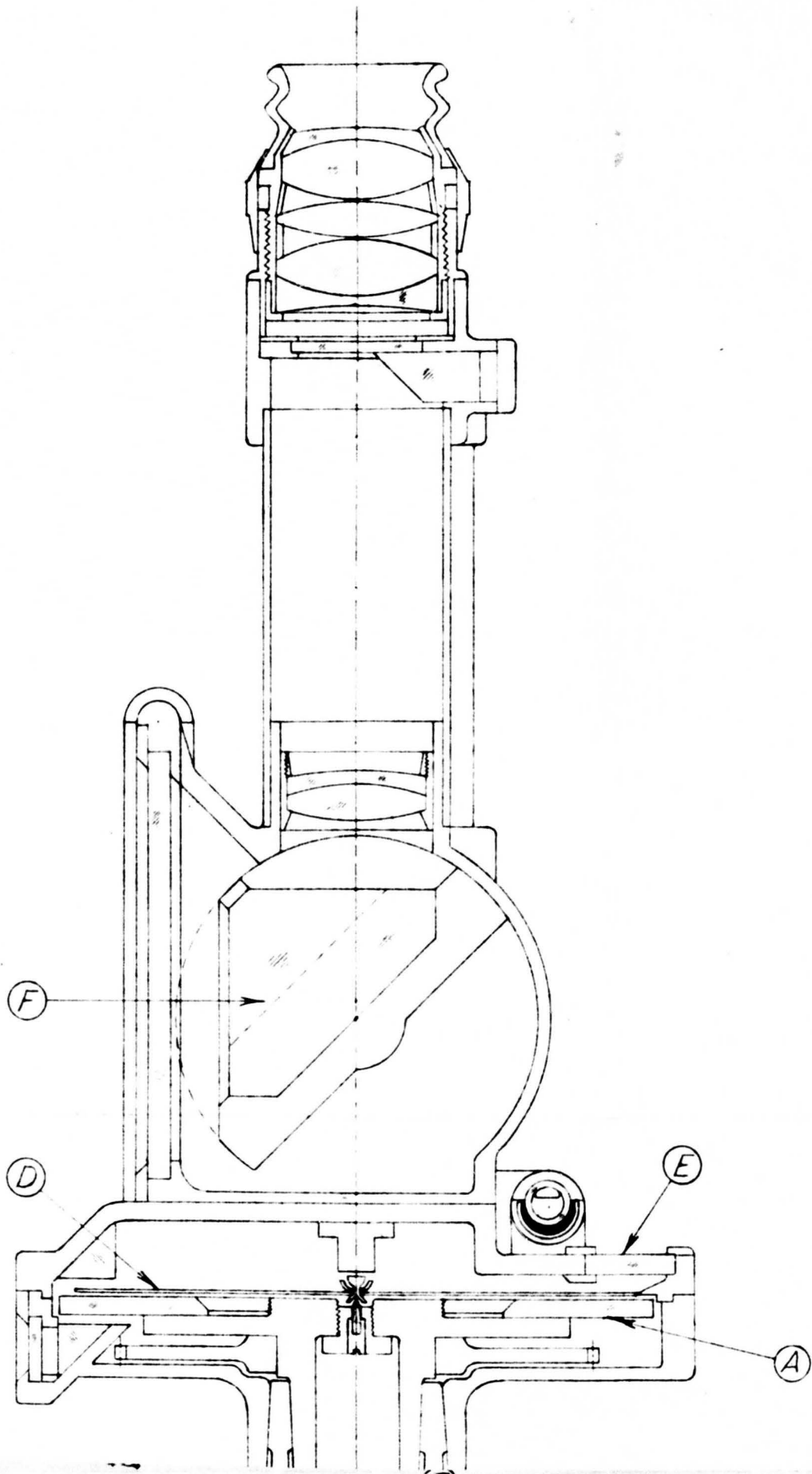

0

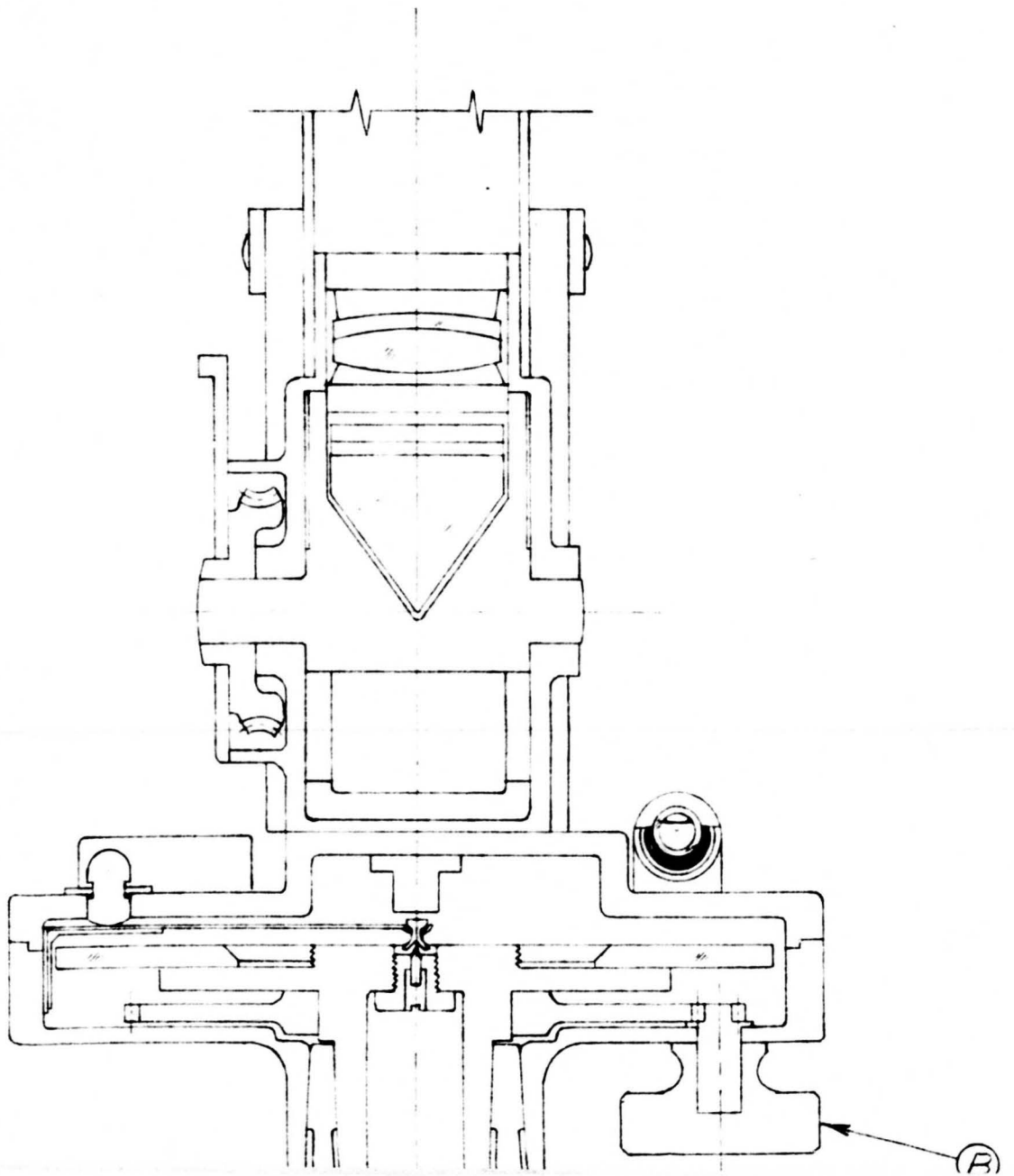

E

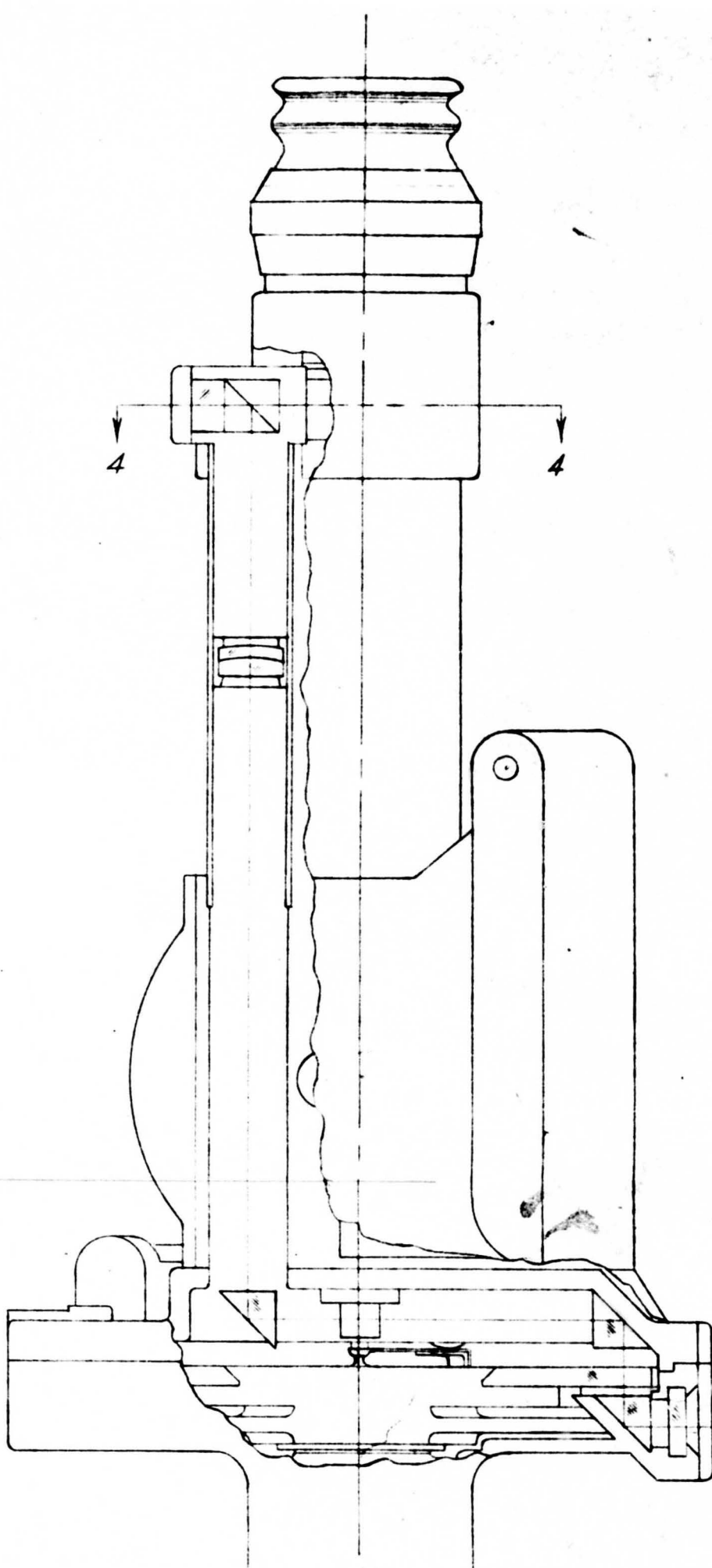

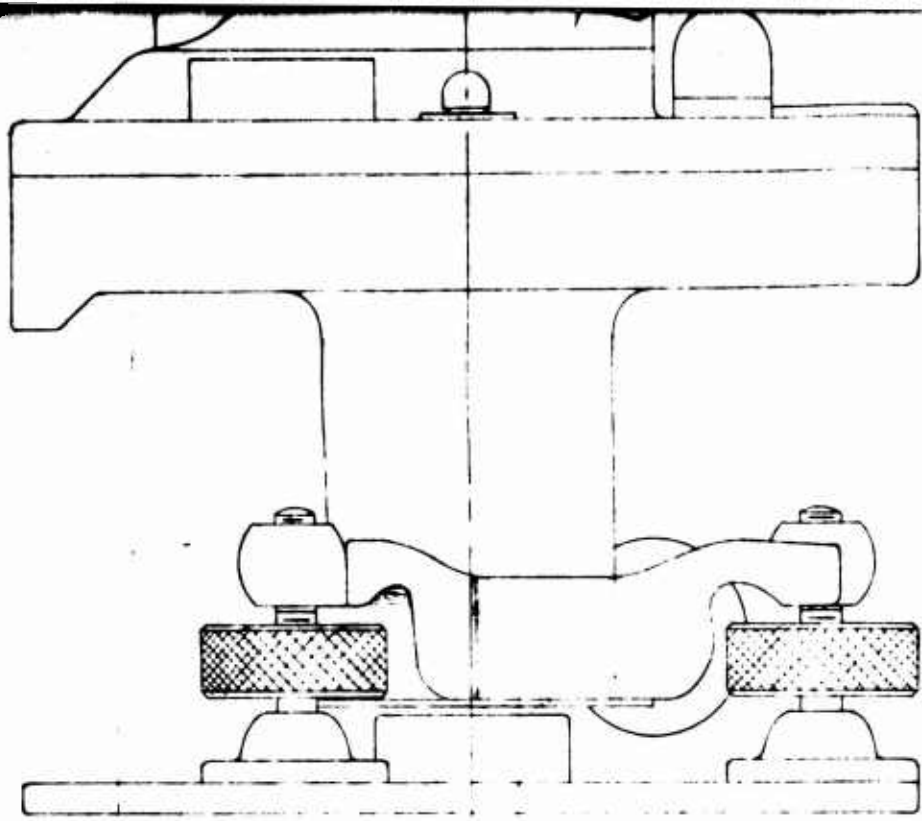

F

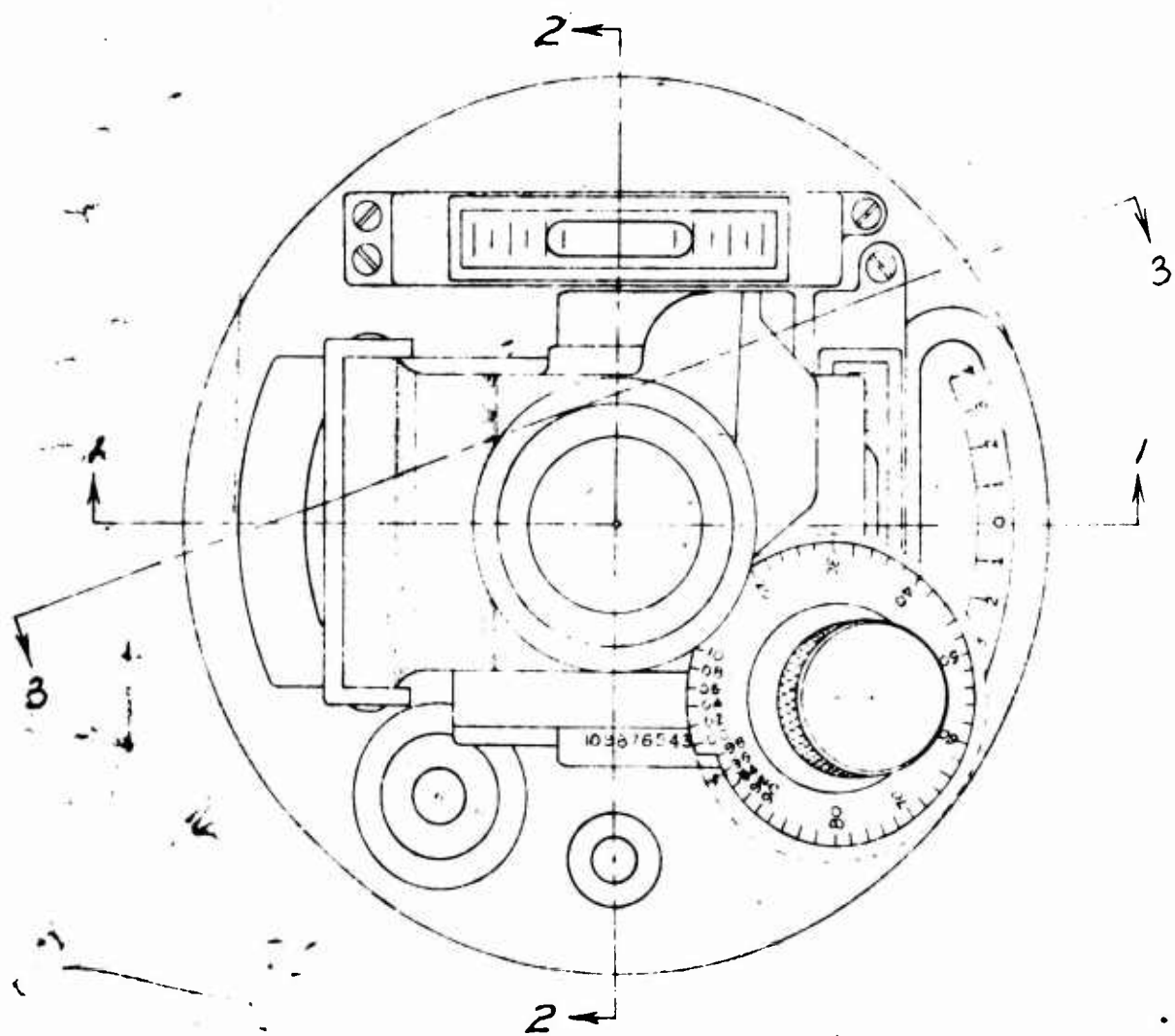

G

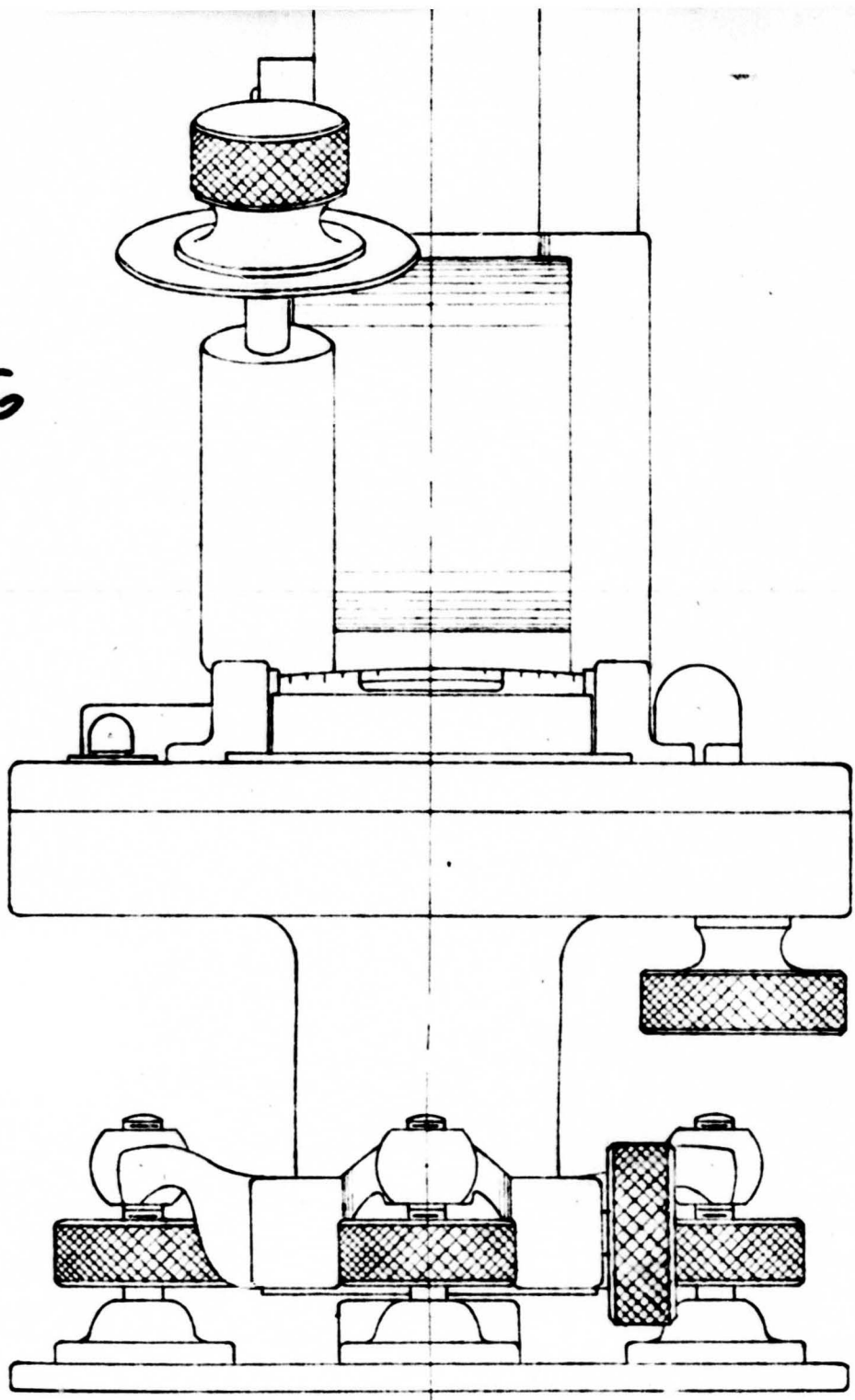

H

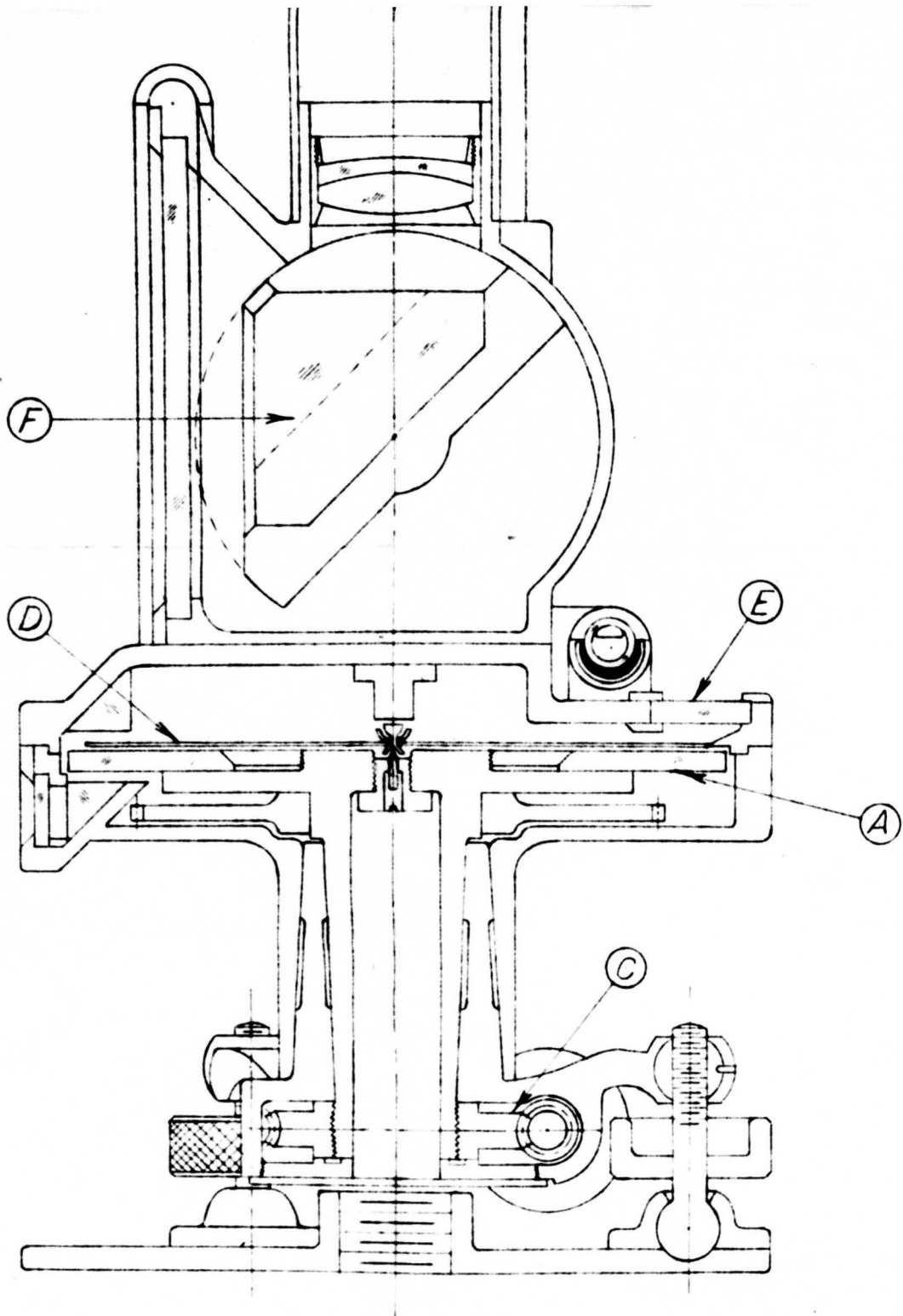

— Section 1-1 —

H

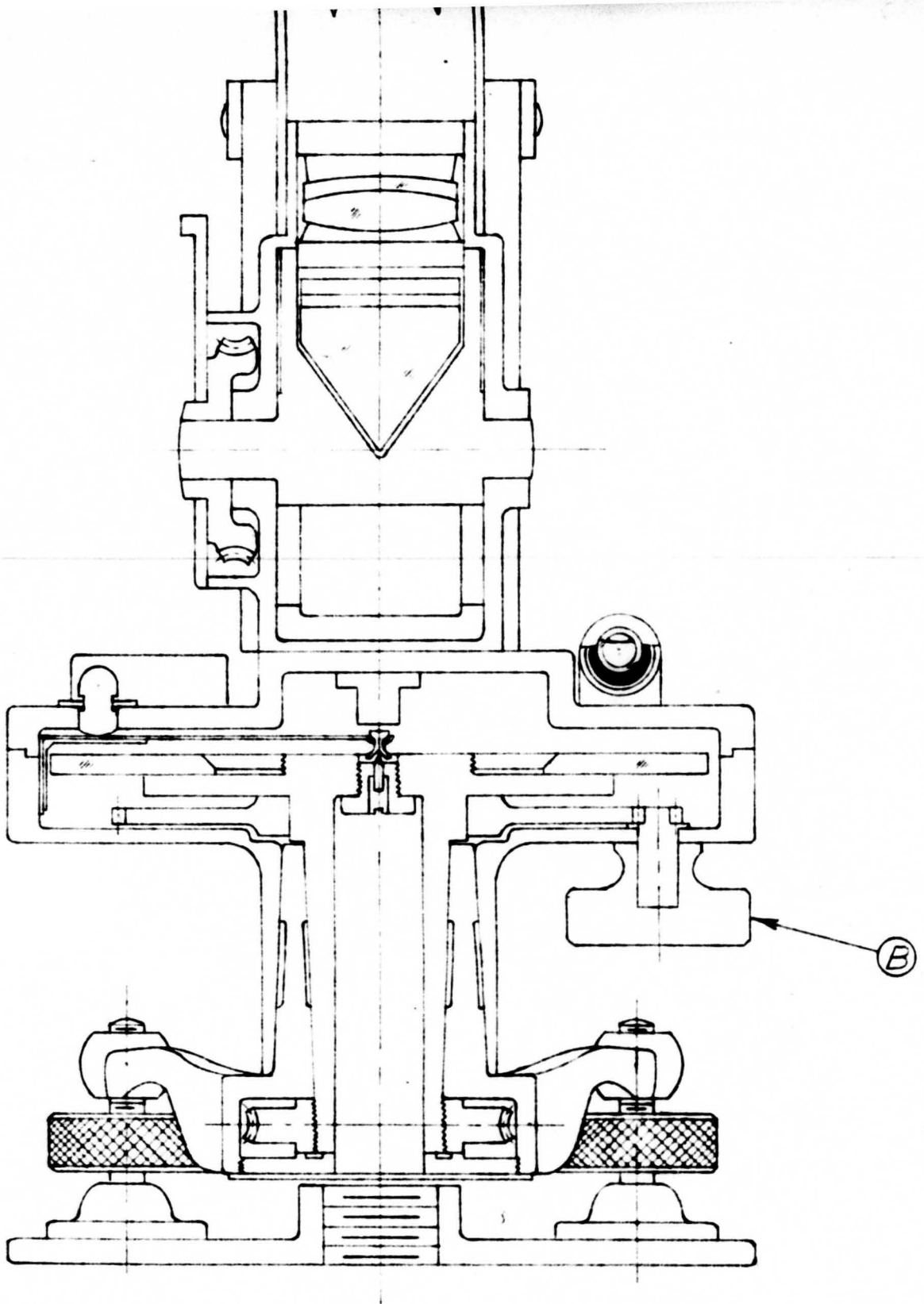

— Section 2-2 —

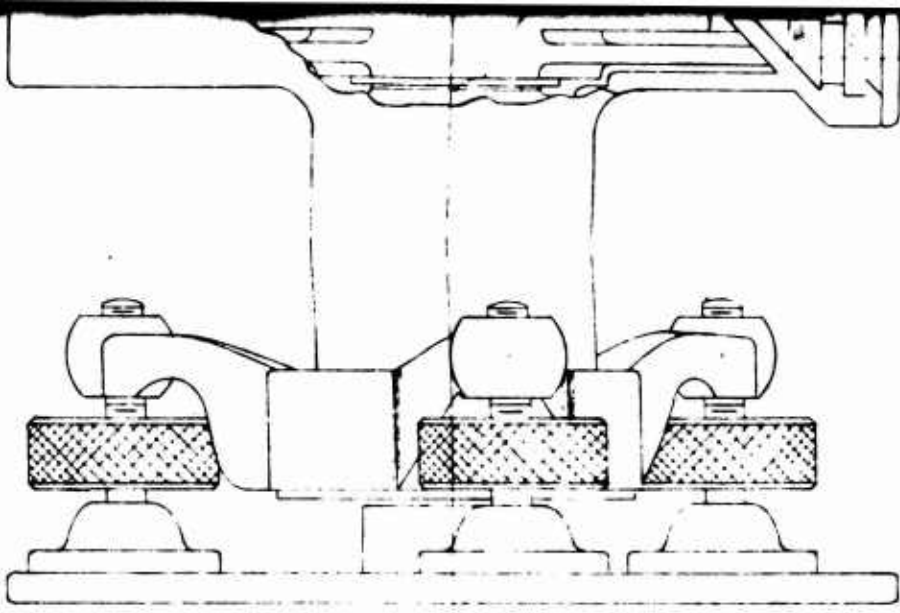

— Section 3-3 —

1

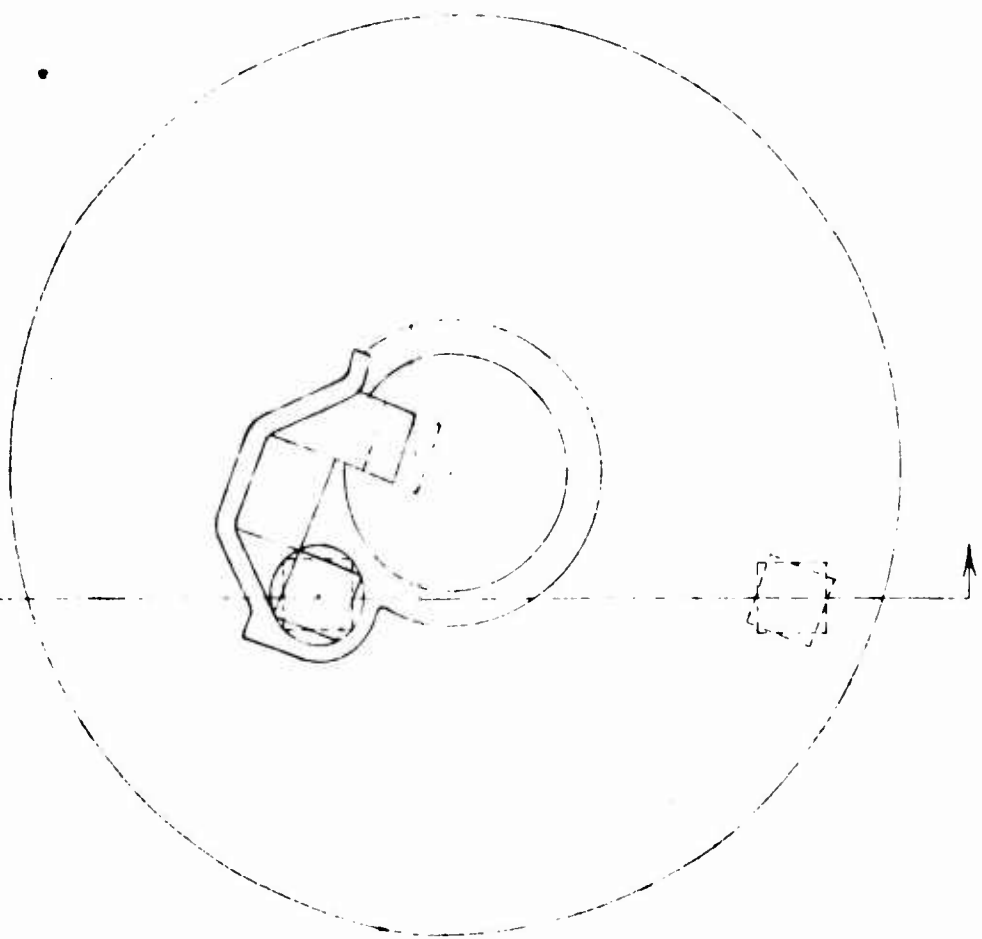

— Section 4-4 —

FIG. 2

4

137

PROPOSED AIMING CIRCLE	
ARMORED MEDICAL RESEARCH LABORATORY FORT KNOX, KENTUCKY	
LT. COL. F. S. BRACKETT	
SCALE FULL SIZE	DATE MARCH 20, 1945

FIG. 3

TELESCOPE FIELD WITH PROJECTED MIL SCALE  
SHOWING INDICATION OF TARGET ON SCALE

(APPROXIMATE PROPORTIONS)

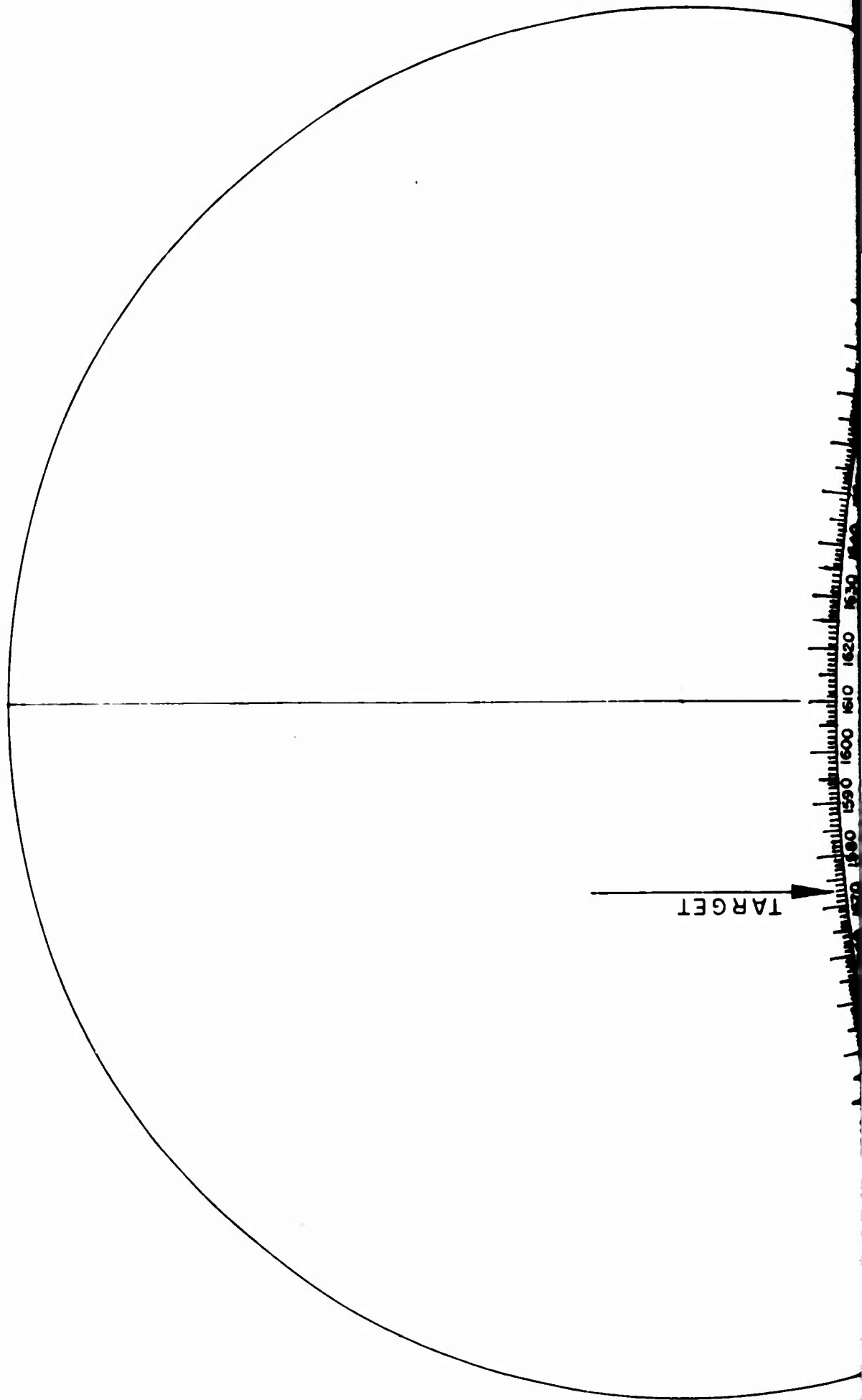

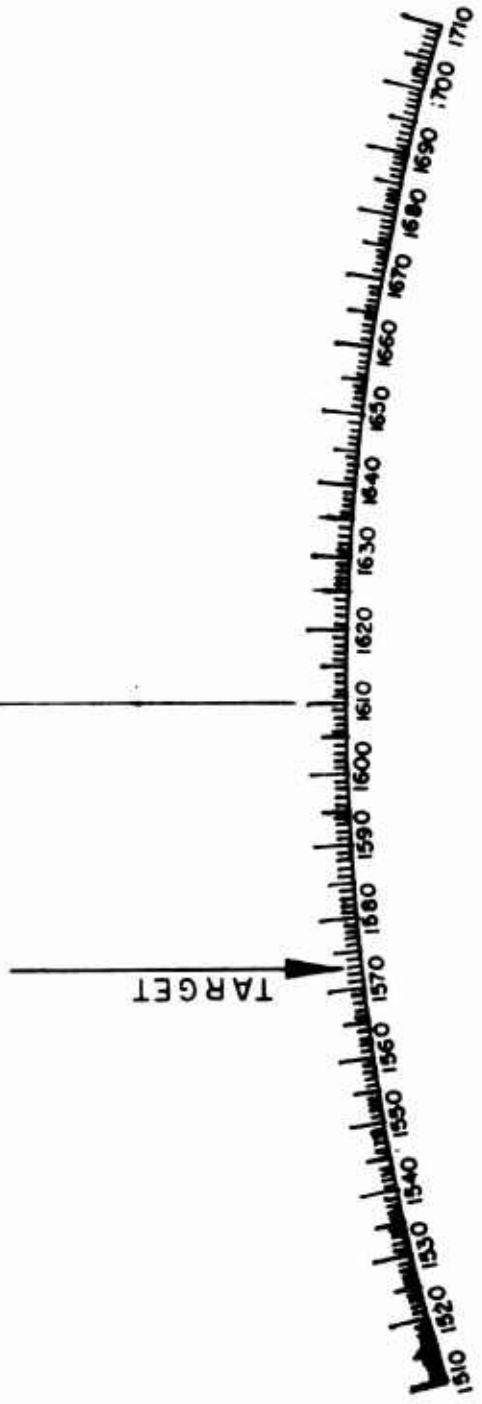

READING - 1573  $\eta$   
FIG. 3

B

Incl. #3

FIG. 4

TELESCOPE FIELD WITH PROJECTED MIL SCALE  
AND PROJECTED COMPASS NEEDLE

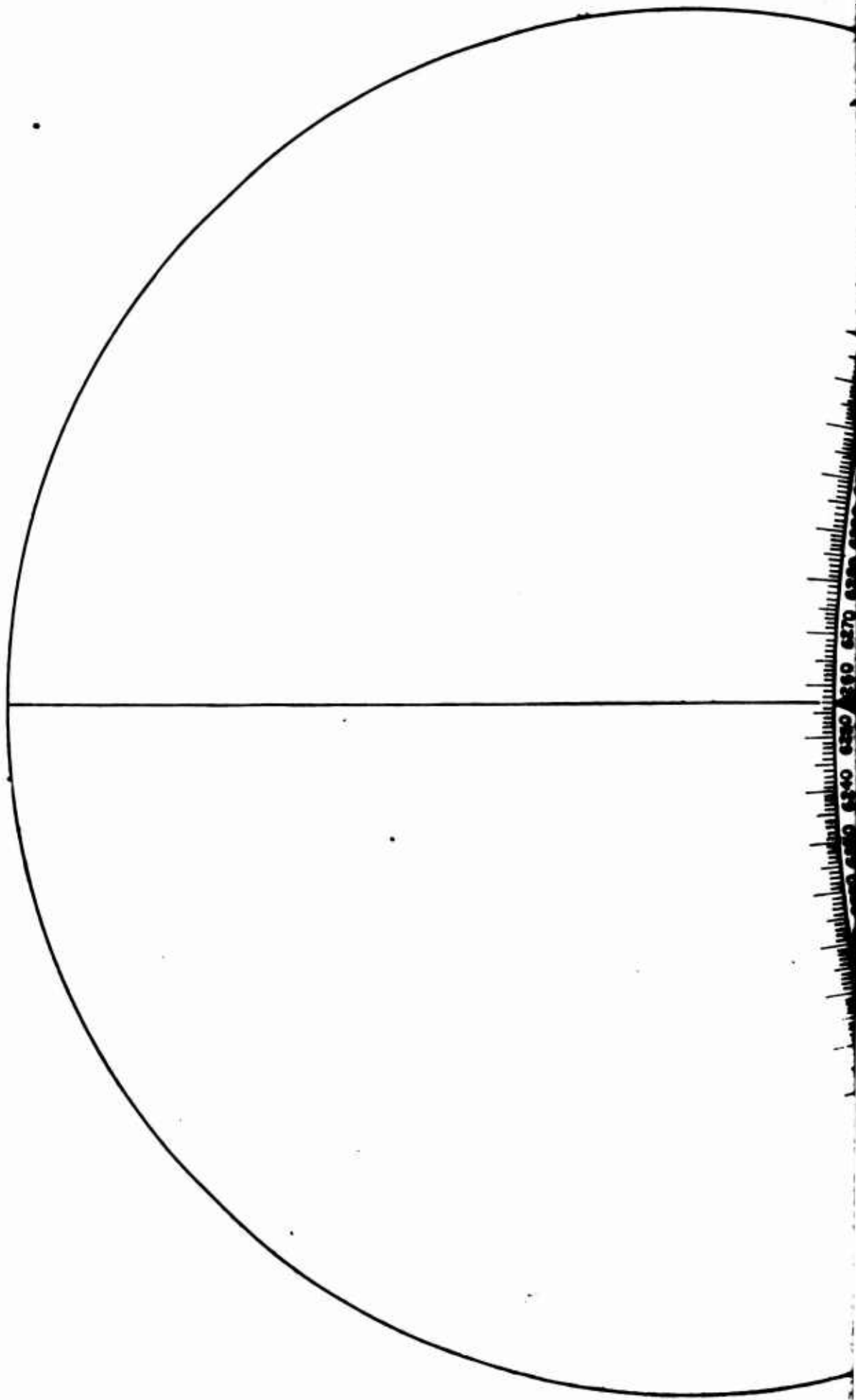

7

6340 6350 6360 6370 6380 6390 6400 6410 6420 6430 6440 6450 6460 6470 6480 6490 6500 6510 6520 6530 6540 6550 6560 6570 6580 6590 6600 6610 6620 6630 6640 6650 6660 6670 6680 6690 6700 6710 6720 6730 6740 6750 6760 6770 6780 6790 6800 6810 6820 6830 6840 6850 6860 6870 6880 6890 6900 6910 6920 6930 6940 6950 6960 6970 6980 6990 7000

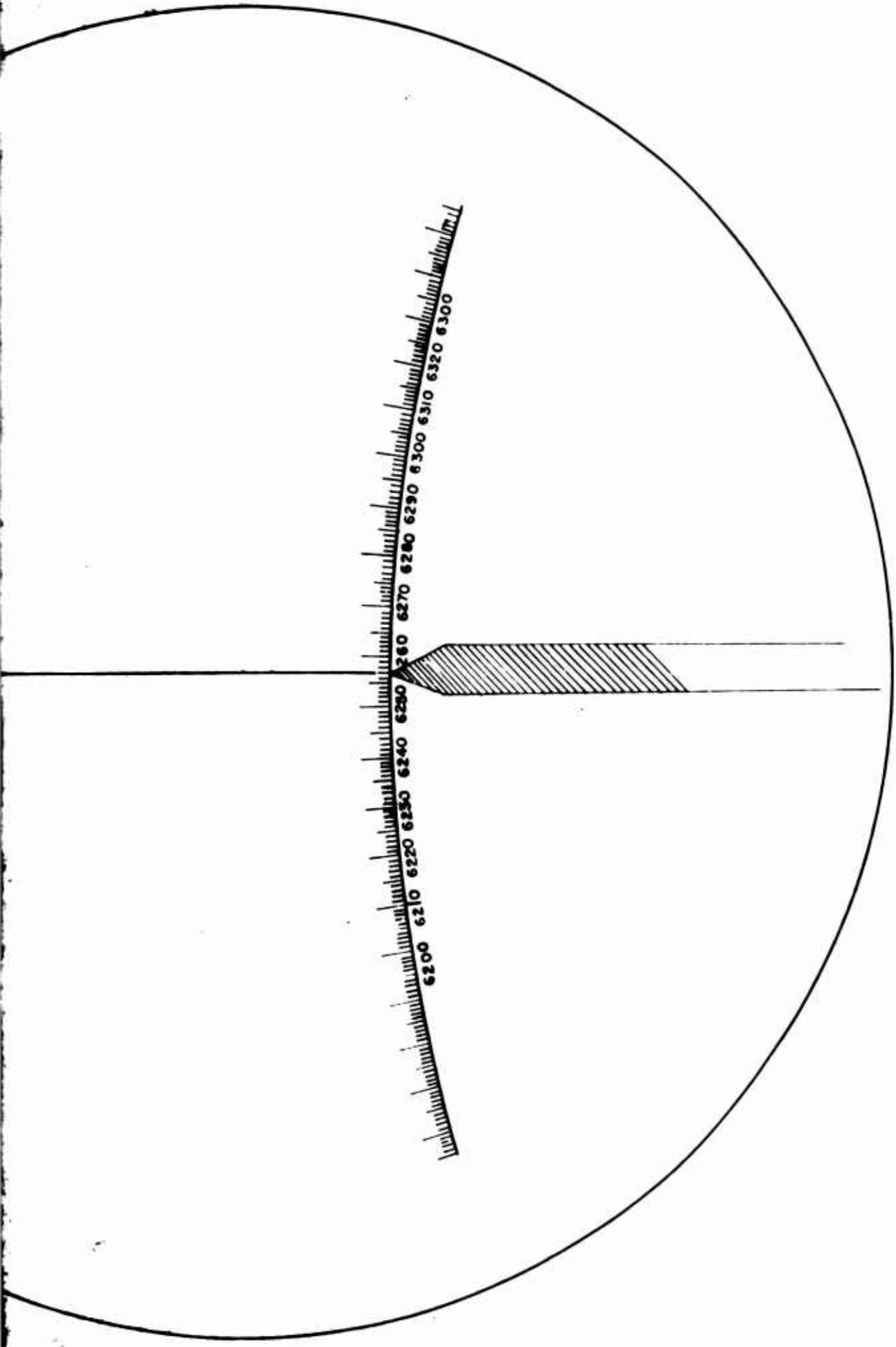

DEFLECTION CONSTANT - 6257  $\mu$   
FIG. 4

5

Incl. #3

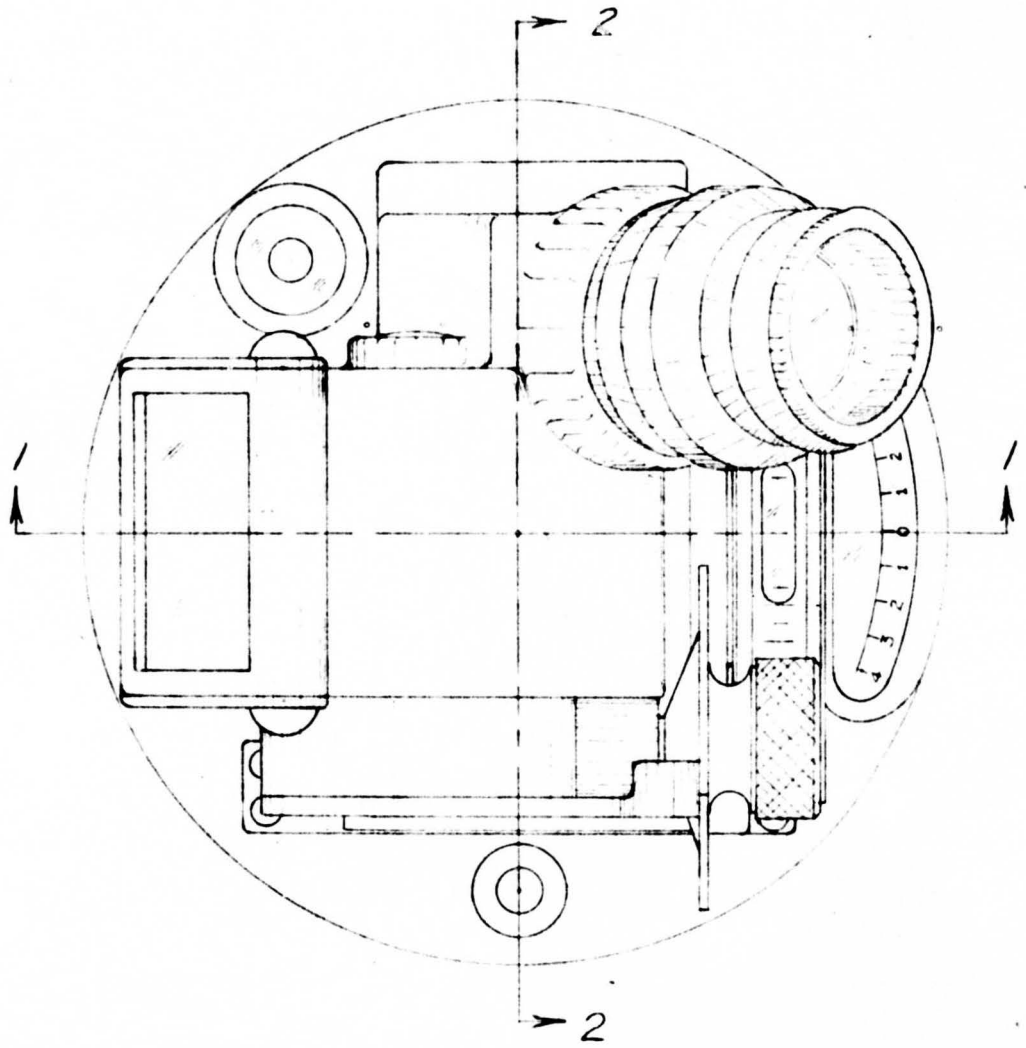

A



B

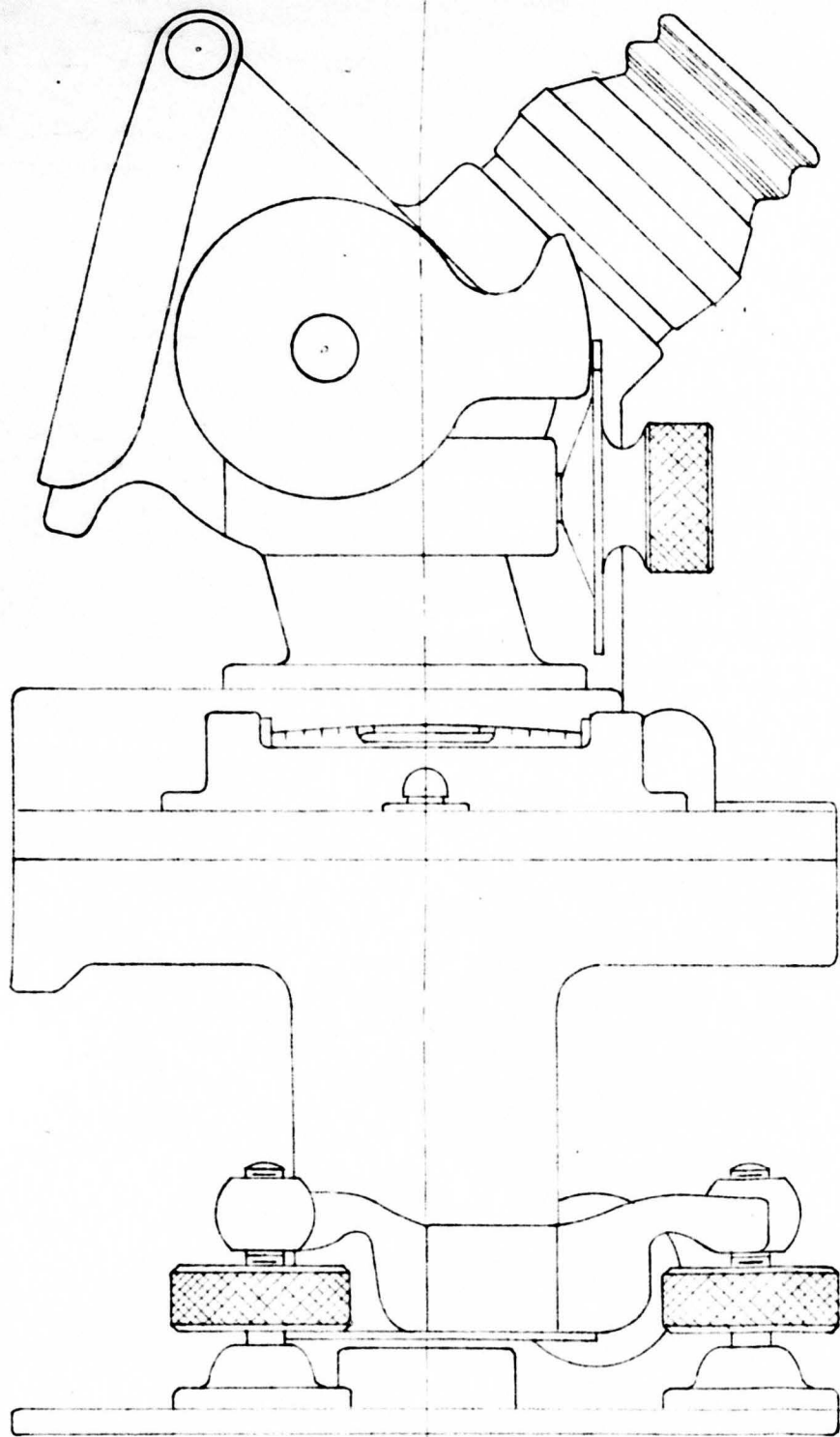

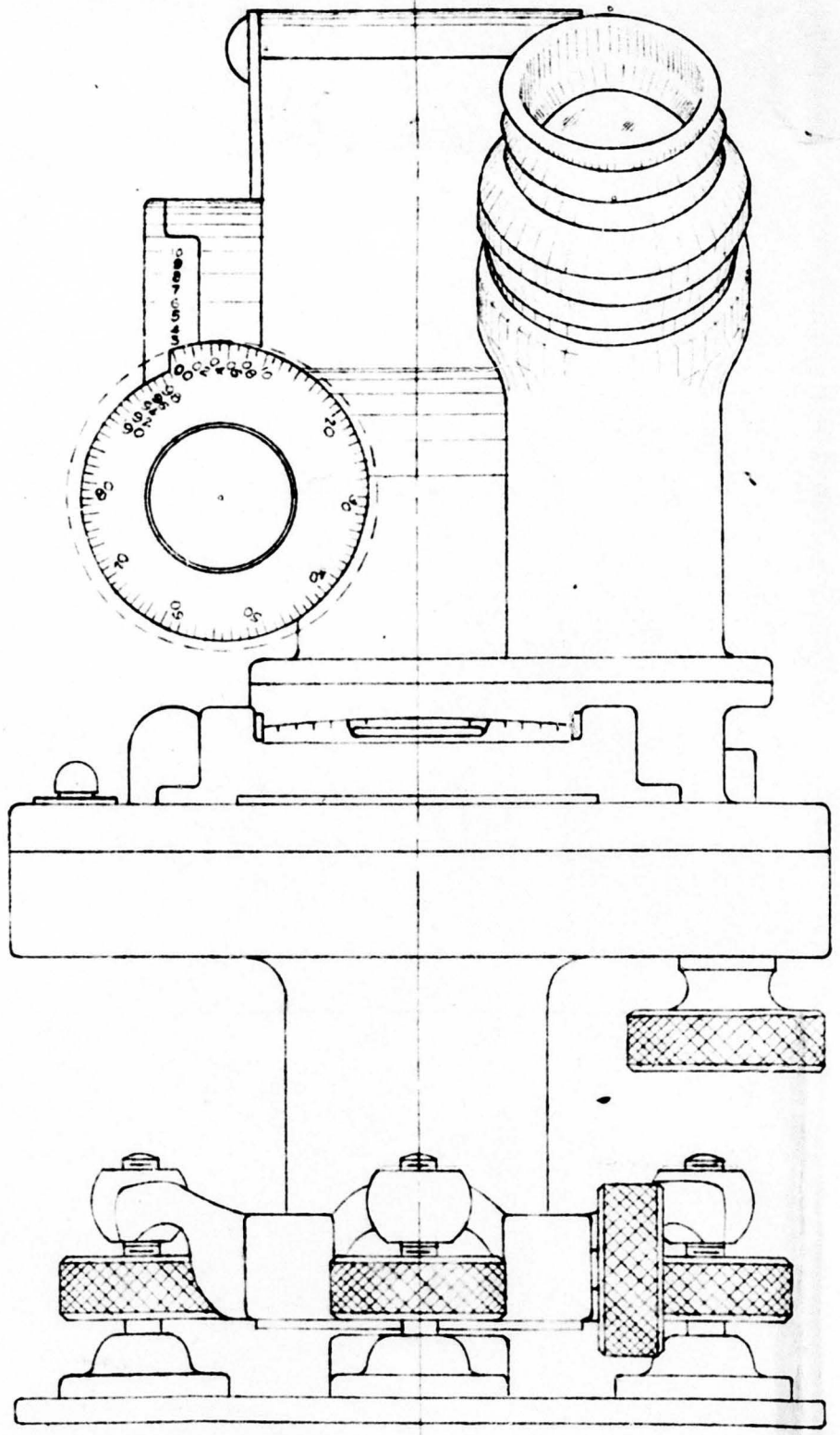

C

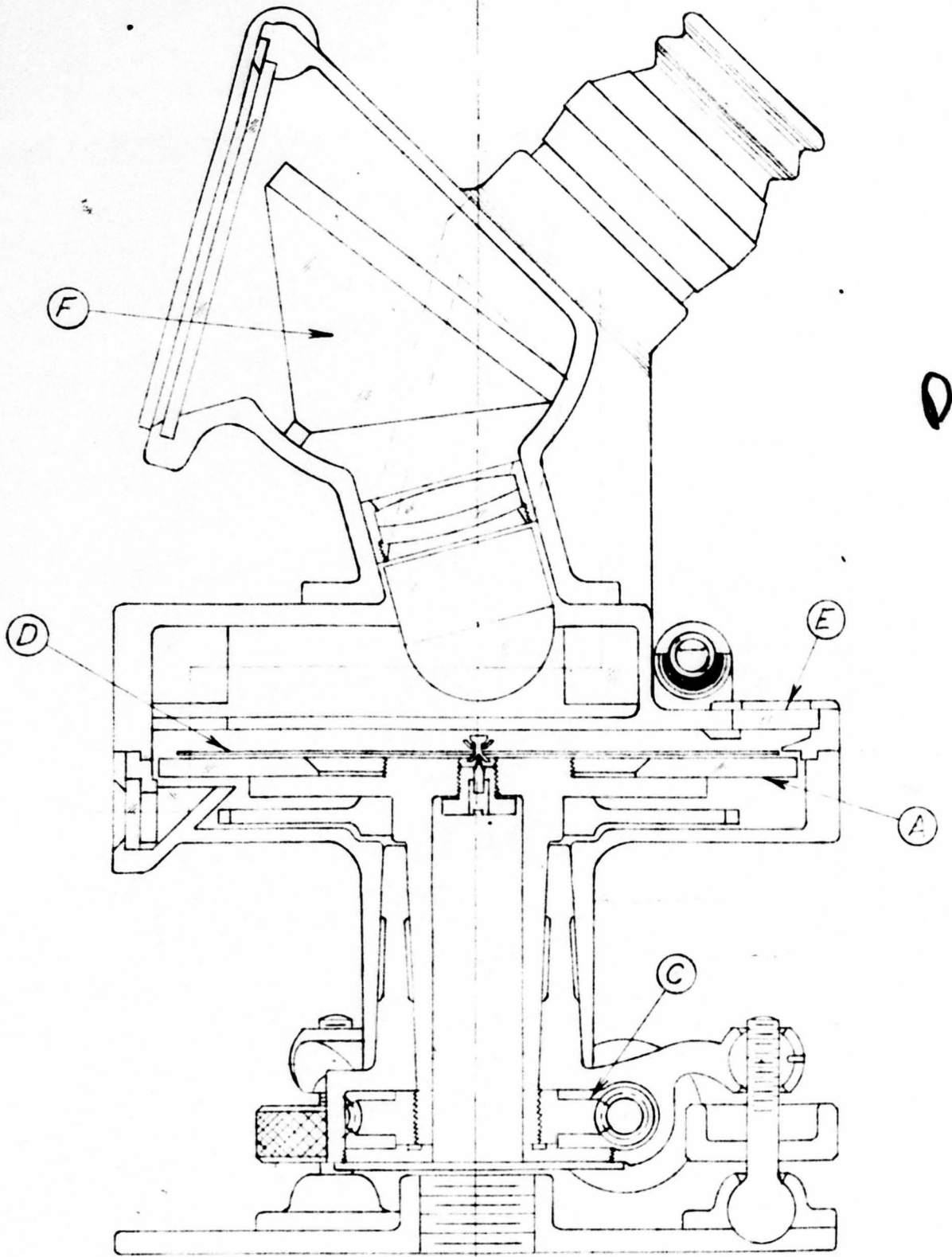

— Section 1-1 —

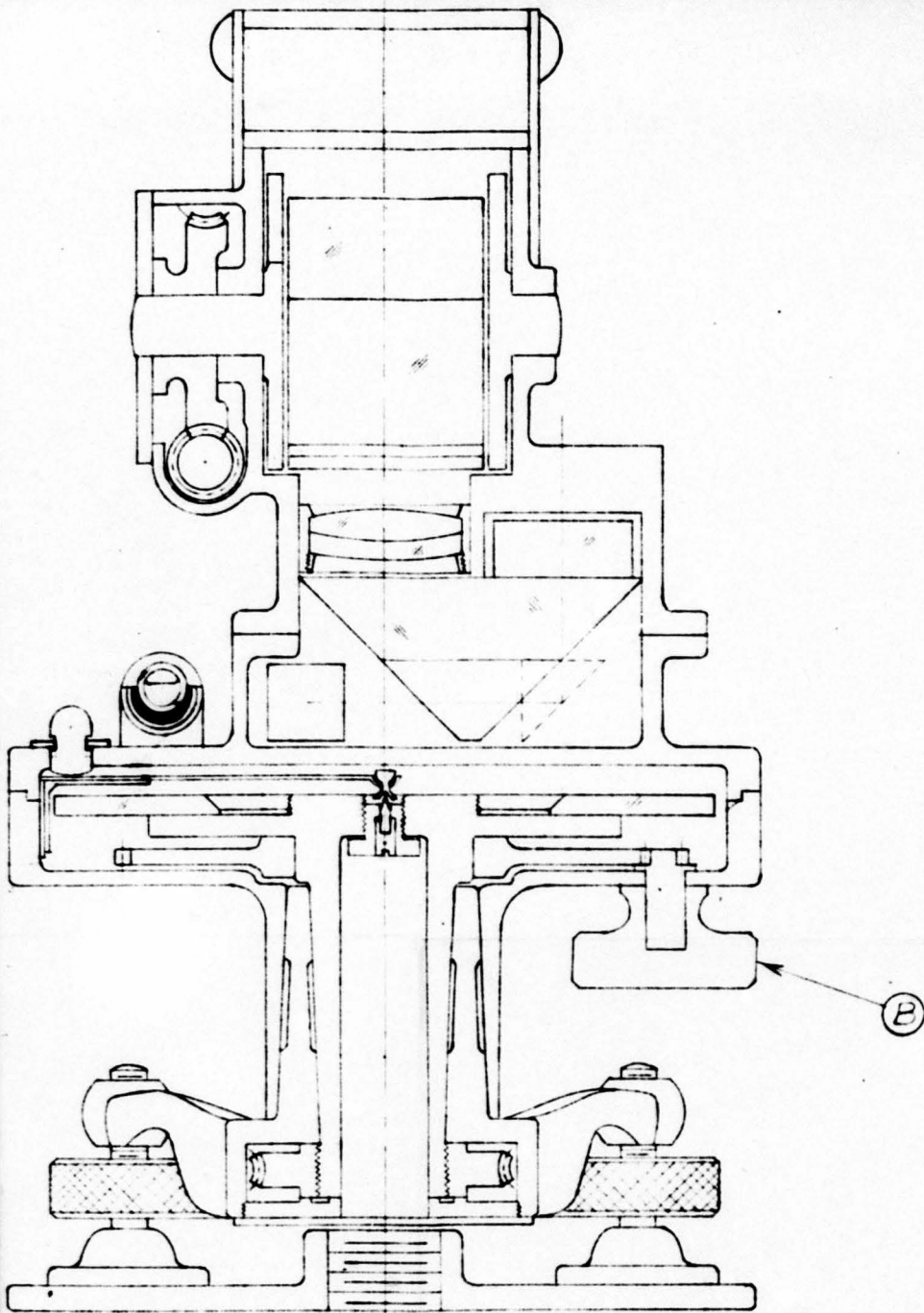

Section 2-2

E

FIG. 5

P37

ALTERNATE INSTRUMENT DESIGN	
ARMORED MEDICAL RESEARCH LABORATORY FORT KNOX, KENTUCKY	
LT. COL. F. S. BRACKETT	
SCALE FULL SIZE	DATE MARCH 28, 1945

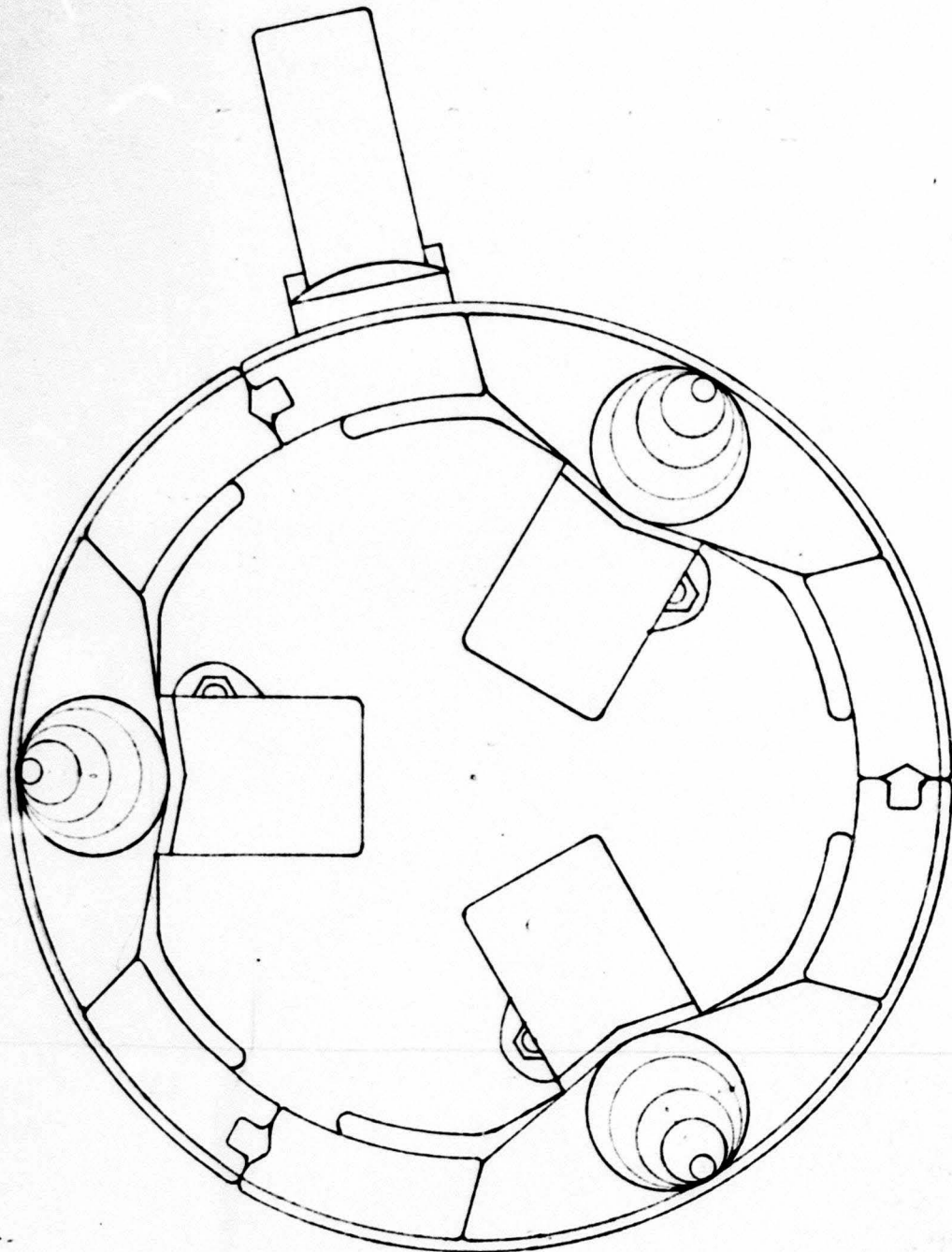

A

— Top View —  
Cap removed

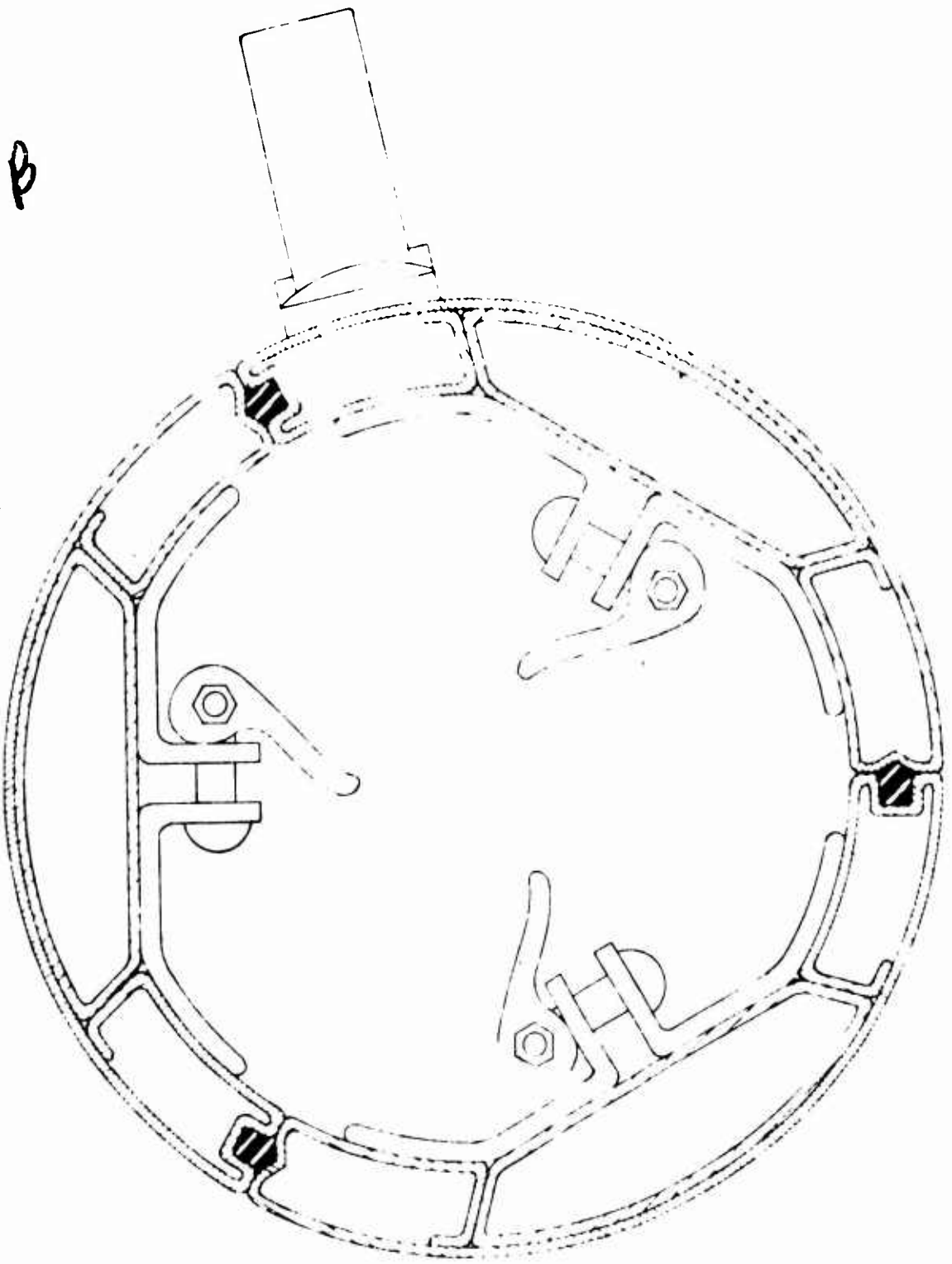

— Section B-B —

C

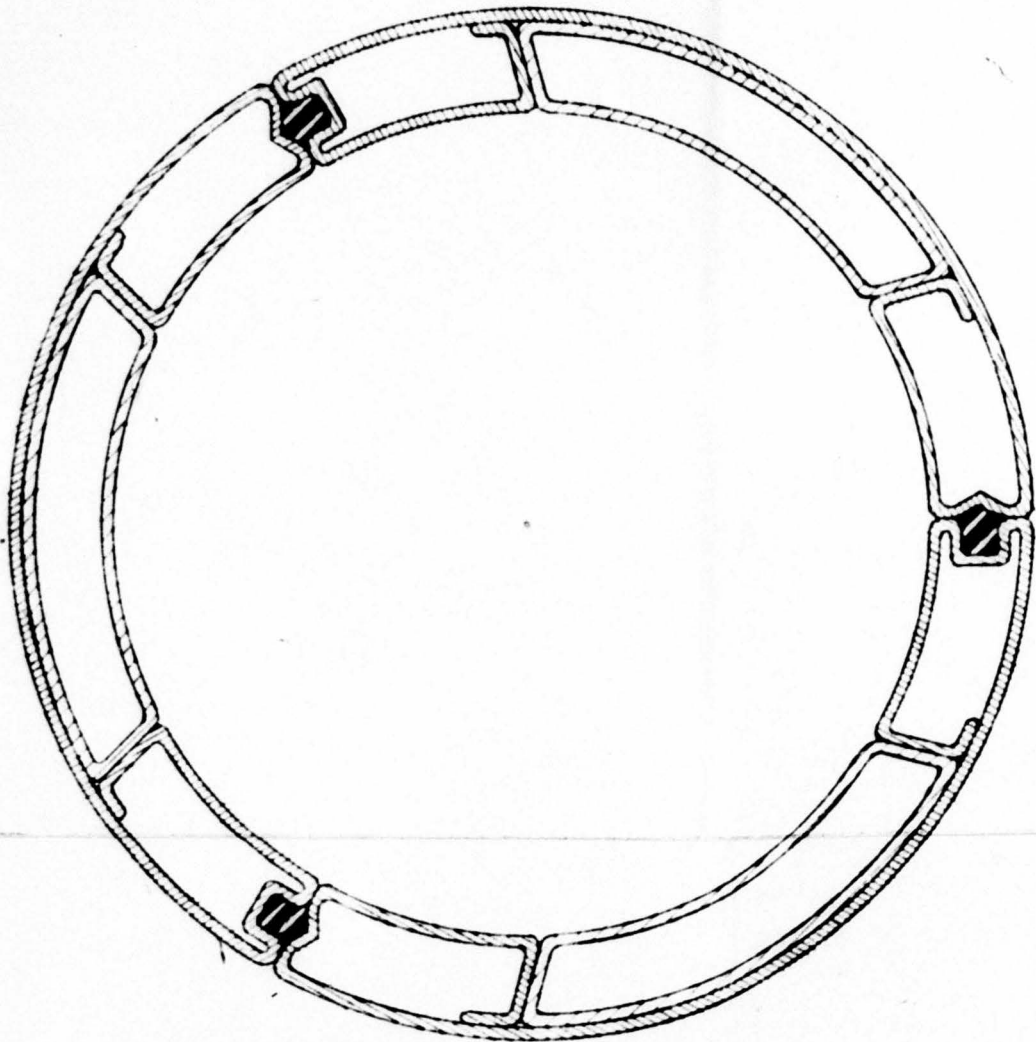

— Section C-C —

E

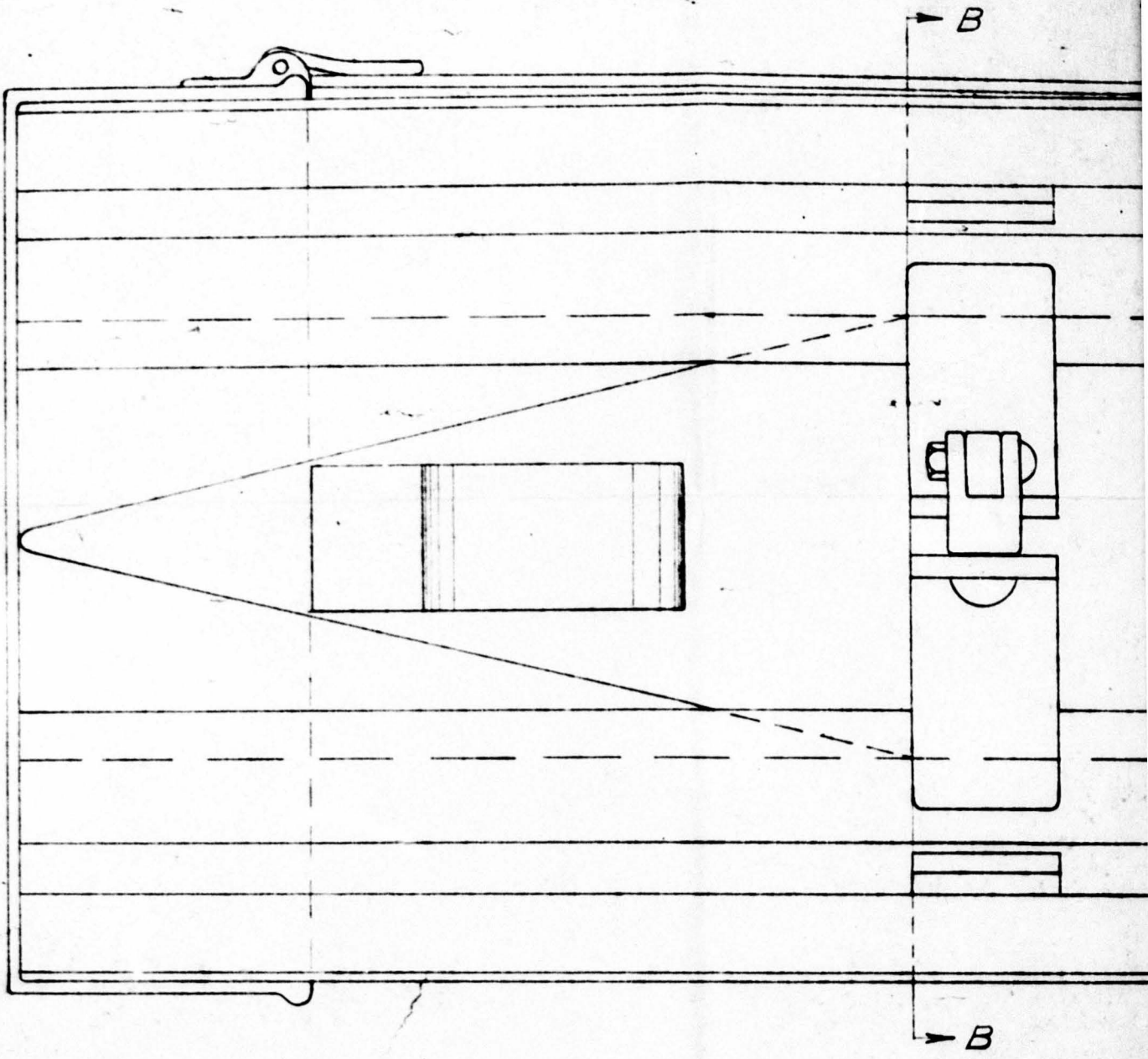

F

B

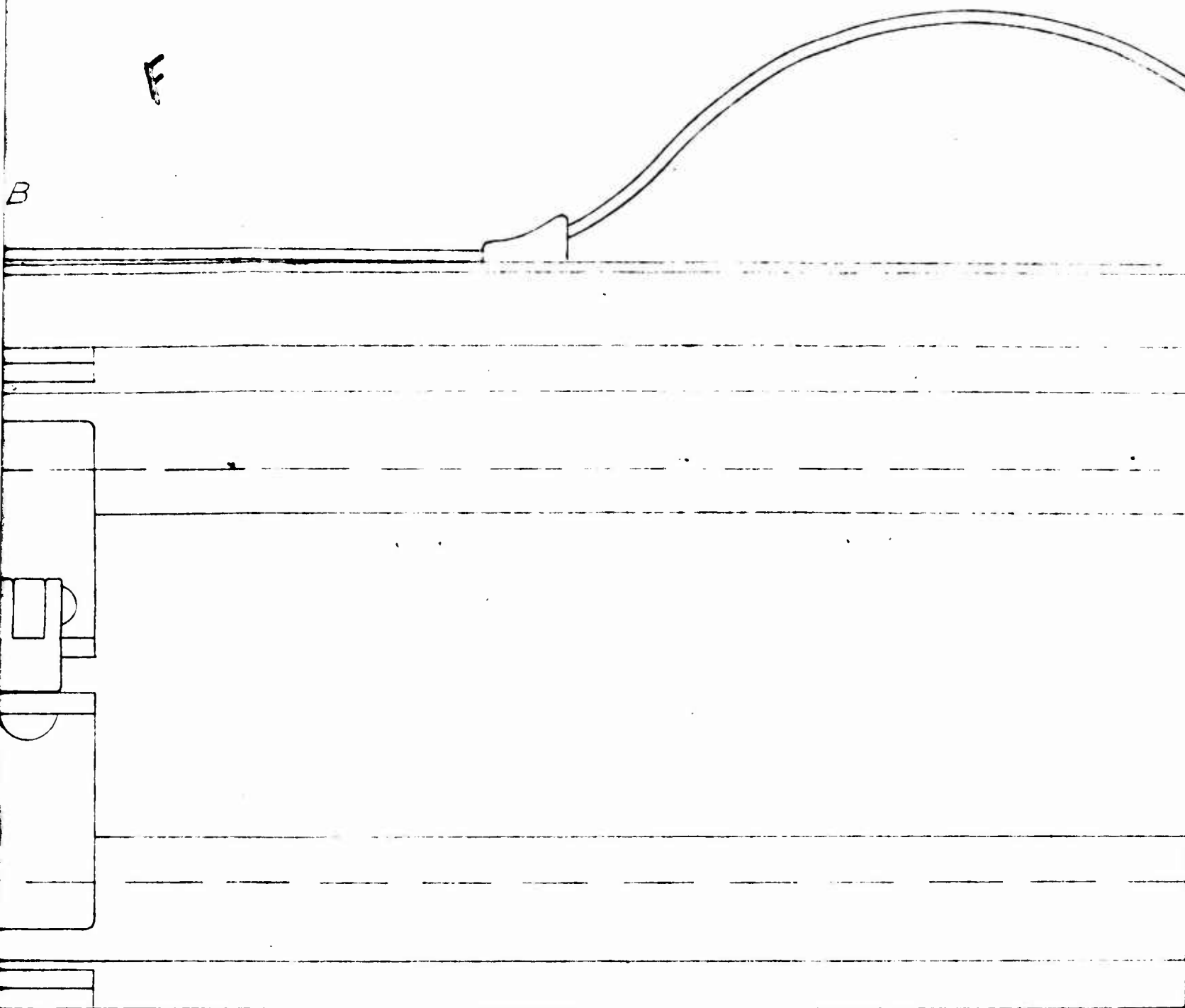

B

— Section A-A —

G

C

C

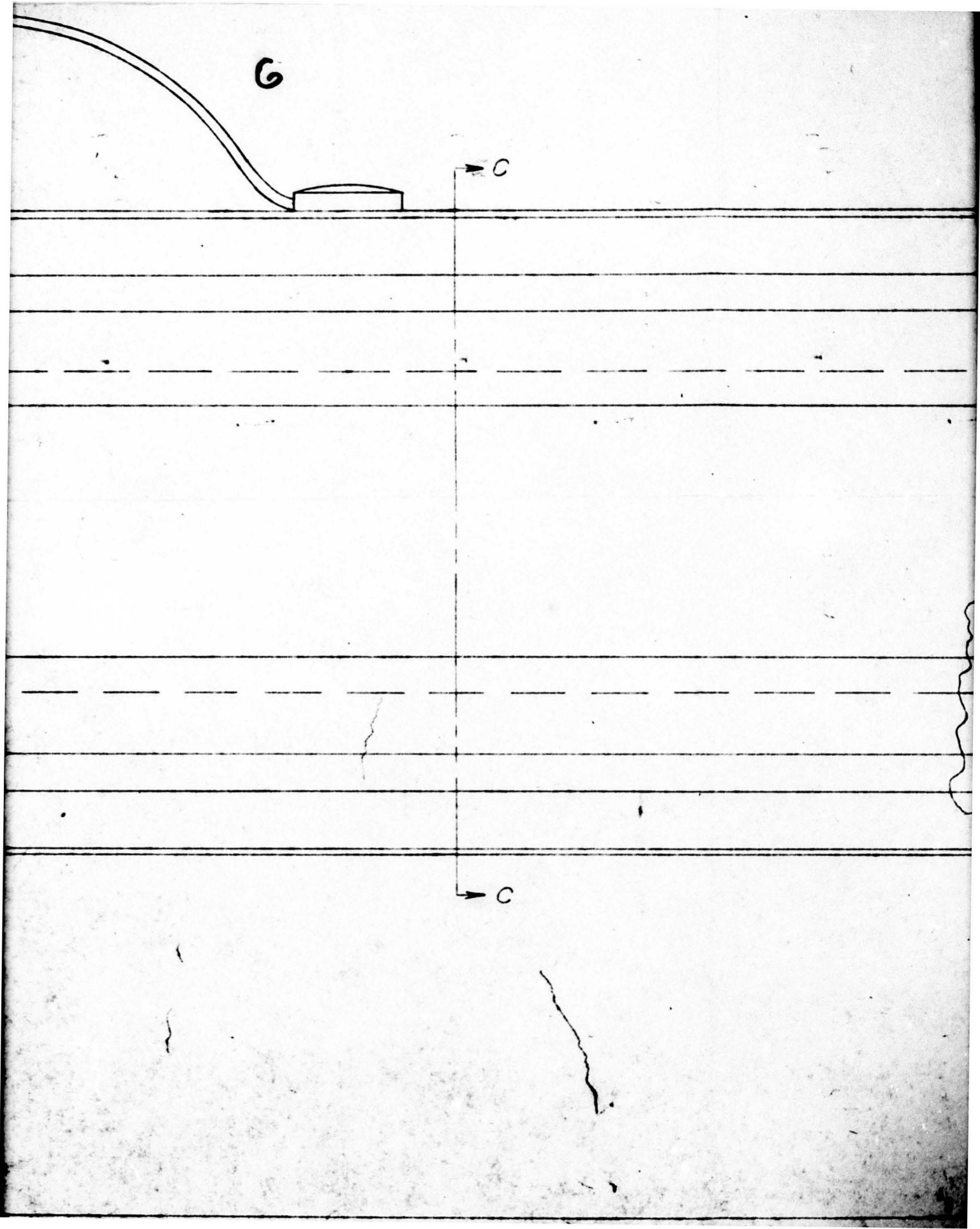

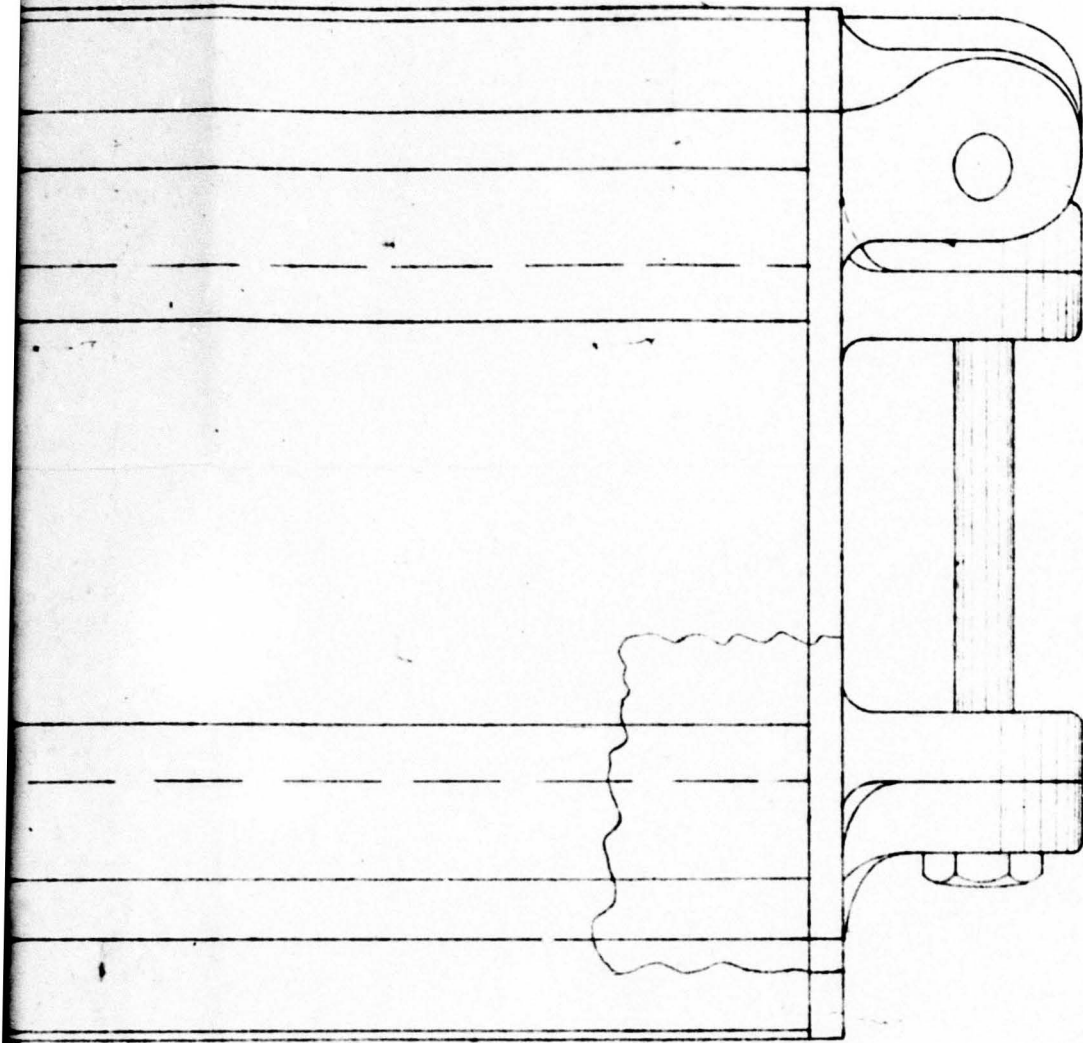

H

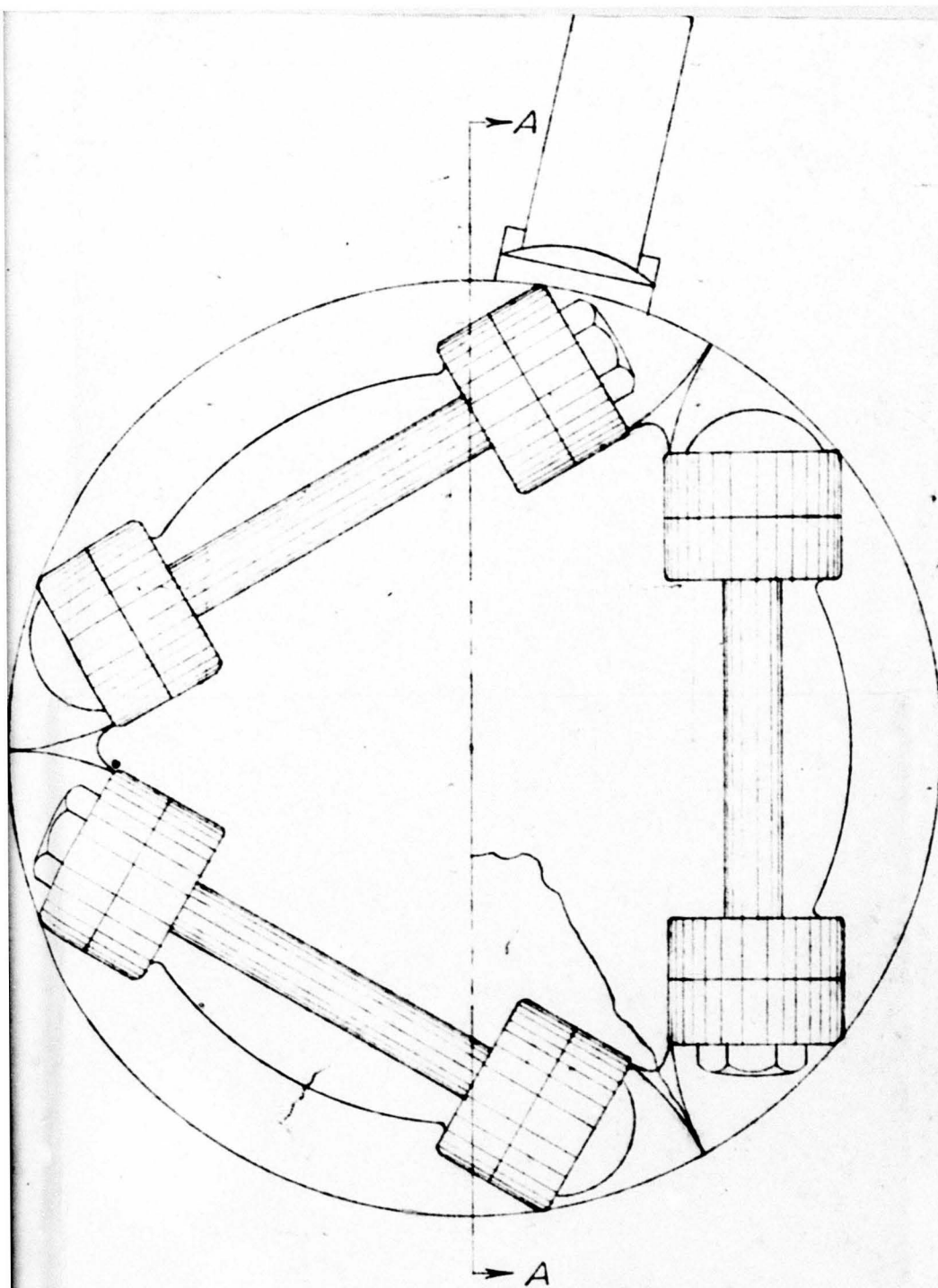

FIG. 6

P37

TRIPOD CARRYING CASE	
ARMORED MEDICAL RESEARCH LABORATORY FORT KNOX, KENTUCKY	
LT. COL. F. S. BRACKETT	
SCALE	FULL SIZE
DATE	MARCH 28, 1918