

AD 661453

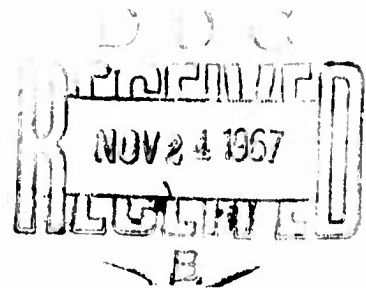

FINAL REPORT

S-244-5

Subcontract No. E-70935(4949a-37)-US

May 1966

HYDRODYNAMIC EFFECTS OF NUCLEAR EXPLOSION  
VOLUME V: THEORETICAL DEVELOPMENTS

**NATIONAL ENGINEERING SCIENCE CO.**



SUBSIDIARY OF PIKE CORPORATION OF AMERICA

711 SOUTH FAIR OAKS AVENUE, PASADENA, CALIFORNIA 91105  
1875 CONNECTICUT AVE., N.W., WASHINGTON, D.C.

Reproduced by the  
CLEARINGHOUSE  
for Federal Scientific & Technical  
Information Springfield Va 22151

92

HYDRODYNAMIC EFFECTS OF NUCLEAR EXPLOSIONS

VOLUME V: THEORETICAL DEVELOPMENTS

Prepared by:

B. J. Le Méhauté  
R. C. Y. Koh  
L. S. Hwang  
C. C. Mei  
D. J. Divoky

Prepared for:

Stanford Research Institute  
Civil Defense Technical Office  
Menlo Park, California

Subcontract No. B-70935(4949A-37)-U. S.

NESCO Report S-244-5

June 1966

This report has been reviewed in the Office of Civil Defense and approved for publication. Approval does not signify that the contents necessarily reflect the views and policies of the Office of Civil Defense.

NATIONAL ENGINEERING SCIENCE COMPANY  
711 South Fair Oaks  
Pasadena, California 91105

Distribution of this document is unlimited.

## SUMMARY

This fifth and final volume of the report, "Hydrodynamic Effects of Nuclear Explosions," presents new theoretical developments for two problems. The first is the determination of the waves resulting from the passage of a high-pressure disturbance over the free surface of a body of water. This would occur in the case of a burst on or over land near a shore and is, therefore, of interest to the Five City Study in which three nuclear surface bursts are near rivers or bays.

The second topic is motion of the ground water table induced by a surface burst. This problem is of interest for the determination of the migration of radioactive contaminants and is also applicable to three cities of the Five City Study.

Only theoretical development is given here. Typical methods of application may be found in Volume IV of this report subtitled "Five City Study."

## CONTENTS

	Page
<b>PART I - WAVES GENERATED BY A TRAVELING DISTURBANCE</b>	
1. ESTABLISHMENT OF THE BASIC EQUATIONS . . . . .	1
2. STEP-FUNCTION PRESSURE OVER A UNIFORMLY SLOPING BEACH . . . . .	9
3. DECAYING PRESSURE OVER A UNIFORMLY SLOPING BEACH . . . . .	15
4. THE CASE OF A CONSTANT-DEPTH CHANNEL . . . . .	19
5. RESPONSE AT LARGE TIME. . . . .	23
6. DISCUSSION. . . . .	31
<b>PART II - GROUND WATER TABLE MOTION</b>	
1. INTRODUCTION. . . . .	35
2. THE FILLING OF A CYLINDRICAL CRATER IN AN UNCONFINED ACQUIFIER . . . . .	37
2.1 Method I: Expansion-in-time Series . . . . .	41
2.2 Method II: Quasi-Steady Solution . . . . .	47
3. THE FILLING OF A CRATER NEAR A RIVER IN AN UNCONFINED AQUIFER . . . . .	59
4. DISCHARGE OF STREAM INTO A LARGE WELL IN A CONFINED AQUIFER. . . . .	67
5. A QUIESCENT WELL IN A UNIFORM FLOW . . . . .	75
6. FLOW INTO A WATER SURROUNDED CRATER. . . . .	85
7. REFERENCES. . . . .	89

**BLANK PAGE**

## NOMENCLATURE

### Part I

- a = decay constant in error function
- f = Laplace transform function
- $f_n$  = friction factors
- g = acceleration of gravity
- h = water depth
- k = variable in Hankel transform
- m, n = summation indices
- s = variable in Laplace transform
- t = time
- u = horizontal particle velocity
- x = horizontal distance from shore
- erf = error function
- erfc = complimentary error function
- A = arbitrary constant
- F = Laplace-Hankel transform of dimensionless surface elevation
- $F(a, b, c, z)$  = hypergeometric function
- G = function
- H = Heaviside step function
- I = integral
- $J_n$  = Bessel function of nth order
- L = length scale
- P = pressure acting upon surface
- $P_0$  = Magnitude of pressure step
- $P_n$  = Legendre function
- $P^*$  = pressure front
- IP = Laplace transform of dimensionless pressure
- Q = Laplace-Hankel transform dimensionless pressure
- Q = magnitude of particle velocity vector

## NOMENCLATURE (Continued)

$S$	=	variable
$T$	=	time scale
$U$	=	horizontal velocity of pressure front
$U_A$	=	wind velocity
$\alpha$	=	beach slope
$\beta$	=	exponential decay factor
$\gamma$	=	dimensionless pressure
$\delta$	=	Dirac delta function
$\zeta$	=	dimensionless surface elevation
$\zeta_d$	=	dynamic response
$\eta$	=	surface elevation
$\theta$	=	$\tau$
$\rho$	=	fluid density
$\rho_A$	=	air density
$\tau$	=	dimensionless time
$\tau_s$	=	shear stress at surface
$\tau_b$	=	shear stress at bottom
$\chi$	=	transcendental function
$\Gamma$	=	contour of integration
$\Gamma$	=	gamma function
$\Delta$	=	variable in transform
$()_t, ()_x$ etc.		refer to partial derivatives
$()_D$		refers to peak depression
$()_E$		refers to peak elevation

### Part II

$d$	=	distance between well and reference point
$f, g$	=	various functions as required in analyses
$h$	=	water depth

**NOMENCLATURE**  
(Concluded)

$\zeta$	=	dimensionless water level ratio
$\theta$	=	angle
$\lambda$	=	distance between crater and river
$\nu$	=	variable
$\rho$	=	fluid density
$\rho$	=	H/R
$\phi$	=	potential function
$\nabla$	=	gradient operator
$\nabla^2$	=	Laplacian operator
$()^*$	refers to	dimensionless variables
$()_0$	refers to	initial value
$()_w$	refers to	transient water level
$()_s$	refers to	stream water level
$()_n$	refers to	successive terms in series solution
$()_t, ()_r, \text{ etc.}$	refers to	partial derivatives

**NOMENCLATURE**  
(Continued)

- $k$  = constant in Darcy law
- $m$  = porosity of soil
- $n$  = summation index
- $p$  = pressure
- $q$  = unit discharge
- $r, \theta, z$  = cylindrical coordinates
- $s$  = drawdown of well
- $t$  = time
- $u$  = particle velocity component in  $r$ -direction
- $w$  = particle velocity component in  $z$ -direction
- $w, x, y, z$  = dummy variables as required
- $A_p$  = particle radius of bed material
- $A_n, B_n$  = constants
- $C$  = concentration
- $C, D$  = constants
- $D$  = Domain
- $D_x, D_y$  = dispersion coefficients
- $E, F$  = variable functions
- $H$  = height of fluid at  $r = \infty$
- $I_0, K_0$  = Bessel functions of 1st and 2nd kinds, respectively
- $K$  = permeability
- $Q$  = discharge rate
- $R$  = cavity, crater or well radius
- $S_f$  = free surface
- $T$  = hydraulic transmissivity
- $U$  = velocity
- $\alpha, \beta$  = variables
- $\gamma$  = specific weight of fluid
- $\nabla$  = datum
- $\epsilon$  = specific yield = effective porosity

PART I

WAVES GENERATED BY A TRAVELING DISTURBANCE

**BLANK PAGE**

## 1. ESTABLISHMENT OF THE BASIC EQUATIONS

Consider a two-dimensional pressure disturbance arriving at the free surface of a body of water, as illustrated in Fig. 1. The response of the water to such a disturbance will be analyzed by means of the long wave equations valid for shallow water:

Continuity:

$$\eta_t + \left[ u (h + \eta) \right]_x = 0 \quad (1)$$

Momentum:

$$u_t + uu_x = -g\eta_x - \frac{1}{\rho} P_x - \frac{\tau_s - \tau_b}{\rho (h + \eta)} \quad (2)$$

where

- x = distance from shore
- t = time after arrival of pressure at shore
- h = h(x) = still water depth
- $\eta$  = surface elevation around still water level
- u = horizontal component of water particle velocity, assumed constant over a vertical
- g = acceleration due to gravity
- $\rho$  = water density
- P = pressure acting on the surface
- $\tau_s$  = shearing stress at the surface
- $\tau_b$  = shearing stress at the bottom

and subscripts are used to denote partial differentiation with respect to themselves.

Of course, it is possible to treat these equations successfully by numerical techniques (finite differences, the method of characteristics). However, through suitable approximation, it is possible to derive analytic solutions, in certain instances, which are sufficient.

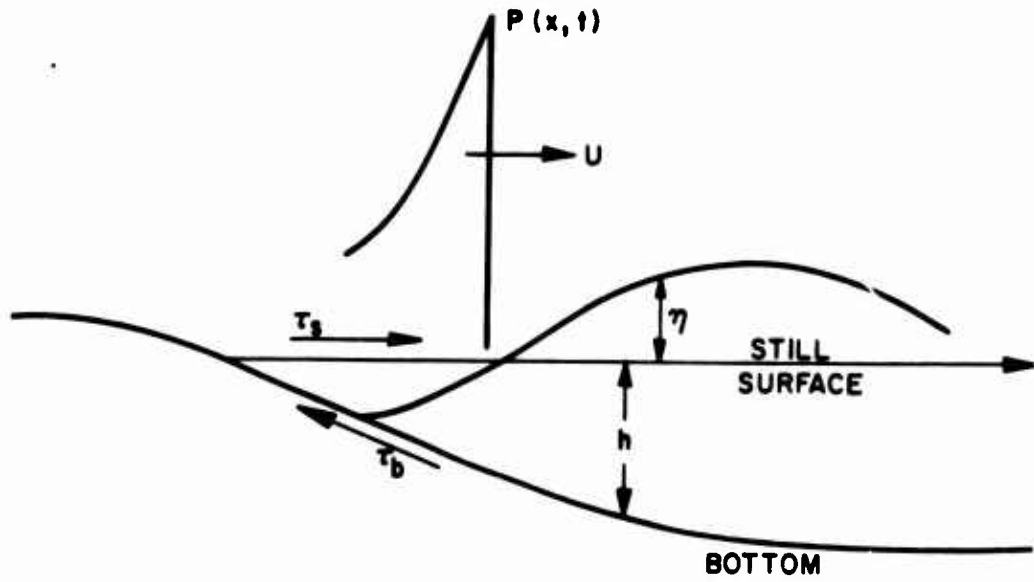

Figure 1  
Problem configuration

The shearing stresses,  $\tau_s$  and  $\tau_b$ , may be written

$$\tau_s = \rho_A f_1 U_A^2$$

$$\tau_b = \rho f_2 u^2$$

where  $\rho_A$  is the air density and  $U_A$  is the wind velocity near the surface. Although  $U_A$  may be large,  $\rho_A$  and  $f_1$  are small so that  $\tau_s$  may be neglected. Similarly, although  $\rho$  is large,  $f_2$  and  $u$  are small so that  $\tau_b$  may be neglected. Hence, the shearing stress term will be neglected; a good approximation except near the shore where  $h + \eta = 0$ .

The equations may be linearized by assuming the convective inertia term,  $uu_x$ , to be small and that  $\eta$  may be neglected in comparison with  $h$  (a crude approximation near the shore). Then the equations become:

Continuity:

$$\eta_t + (uh)_x = 0 \quad (3)$$

Momentum:

$$u_t = -g\eta_x - \frac{1}{\rho} P_x \quad (4)$$

Differentiating Eq. 3 by  $\partial/\partial t$  and Eq. 4 by  $\partial/\partial x$  gives

$$\eta_{tt} + u_t h_x + u_{xt} h = 0 \quad (5)$$

and

$$u_{xt} = -g\eta_{xx} - \frac{1}{\rho} P_{xx} \quad (6)$$

Eliminating  $u_t$  and  $u_{xt}$  from Eq. 5 by means of Eq. 4 and Eq. 6 results in an equation for  $\eta$ :

$$\eta_{tt} - h_x (g\eta_x + \frac{1}{\rho} P_x) - h (g\eta_{xx} + \frac{1}{\rho} P_{xx}) = 0 \quad (7)$$

For a uniformly sloping beach,  $h = \alpha x$ , one has

$$x \eta_{xx} + \eta_x - \frac{1}{\alpha g} \eta_{tt} = - \frac{1}{\rho g} (xP_{xx} + P_x) \quad (8)$$

By defining time and length scales

$$T \equiv U/\alpha g \quad (9)$$

$$L \equiv U^2/\alpha g \quad (10)$$

where  $U$  is some (constant) typical velocity, one may introduce the dimensionless variables

$$\left. \begin{aligned} \zeta &\equiv \eta/L \\ \chi &\equiv x/L \\ \tau &\equiv t/T \\ \gamma &\equiv P/\rho g L \end{aligned} \right\} \quad (11)$$

which, when substituted in Eq. 8, gives

$$\chi \zeta_{\chi\chi} + \zeta_\chi - \zeta_{\tau\tau} = - (\chi \gamma_{\chi\chi} + \gamma_\chi) \quad (12)$$

Assuming no initial disturbance, the initial conditions are

$$\zeta(\chi, 0) = \zeta_\tau(\chi, 0) = 0 \quad (13)$$

The boundary condition is imposed that

$$\zeta \rightarrow 0 \quad \text{as} \quad \chi \rightarrow \infty \quad (14)$$

The general solution of this initial boundary value problem can be found by first applying the Laplace transform to  $\tau$ , making the change of variable

$$\xi = \sqrt{\chi}$$

and then applying the Hankel transform of zeroth order to  $\xi$ .

The Laplace transform of Eq. 12 with respect to  $\tau$  is

$$\chi f'' + f' - s^2 f = -(\chi P'' + P') \quad (15)$$

where

$$f(\chi, s) = \int_0^{\infty} \zeta(\chi, \tau) e^{-s\tau} d\tau \quad (16)$$

$$P(\chi, s) = \int_0^{\infty} \gamma(\chi, \tau) e^{-s\tau} d\tau \quad (17)$$

and primes denote differentiation with respect to  $\chi$ .

Introducing the change of variable

$$\xi = \sqrt{\chi} \quad (18)$$

Eq. 15 becomes

$$\frac{d^2 f}{d\xi^2} + \frac{1}{\xi} \frac{df}{d\xi} - 4s^2 f = -\left( \frac{d^2 P}{d\xi^2} + \frac{1}{\xi} \frac{dP}{d\xi} \right) \quad (19)$$

Letting

$$F(k) = \int_0^{\infty} f(z) J_0(kz) dz \quad (20)$$

$$Q(k) = \int_0^{\infty} P(z) J_0(kz) dz \quad (21)$$

and using the property

$$\int_0^{\infty} \left( \frac{d^2 f}{dz^2} + \frac{1}{z} \frac{df}{dz} \right) J_0(kz) dz = -k^2 F \quad (22)$$

the Hankel transform of Eq. 19 gives

$$F = - \frac{k^2 Q}{k^2 + 4s^2} \quad (23)$$

Then the solution obtained by inversion transforms is found to be

$$\zeta(\chi, \tau) = -\gamma(\chi, \tau) + \frac{1}{2\pi i} \int_{c-i\infty}^{c+i\infty} ds e^{s\tau} \int_0^{\infty} dk k J_0(kz) \frac{4s^2 Q}{(k^2 + 4s^2)} \quad (24a)$$

The first part of this expression clearly represents the hydrostatic response, whereas the integral term represents the dynamic response which will be denoted by  $\zeta_d$ . That is,

$$\zeta(\chi, \tau) = -\gamma(\chi, \tau) + \zeta_d \quad (24b)$$

Before presenting detailed analyses of this solution in specific cases, it is of interest to present a simplified calculation of the small time response. Neglecting the gravity terms in Eq. 7 results in

$$\zeta_{\tau\tau} \approx \chi \gamma_{\chi\chi} + \gamma_{\chi} \quad (25)$$

A pressure wave possessing a sharp front moving at speed  $U$  in the positive  $\chi$  direction can be represented as:

$$\gamma(\chi, \tau) = \gamma(\tau - \chi) = H(\tau - \chi) P^*(\tau - \chi) \quad (26)$$

where  $H$  is the Heaviside step function and  $P^*$  is continuous. Because of the form of  $P^*$ , one may replace  $\partial\gamma/\partial\chi$  by  $-(\partial\gamma/\partial\tau)$  in Eq. 25:

$$\zeta_{\tau\tau} \approx \chi \gamma_{\tau\tau} - \gamma_{\tau} \quad (27)$$

Making use of Eq. 13 and the identity

$$\int_0^{\tau} H(\tau - \chi) P^*(\tau - \chi) d\tau = H(\tau - \chi) \int_0^{\tau - \chi} P^*(z) dz \quad (28)$$

one obtains

$$\zeta \approx H(\tau - \chi) \left\{ \chi P^*(\tau - \chi) - \int_0^{\tau - \chi} P^*(z) dz \right\} \quad \tau \ll 1 \quad (29)$$

This may be generalized for an arbitrary bottom  $y = -h(\chi)$  and any pressure distribution traveling unchanged at constant speed,  $\gamma = \gamma(\tau - \chi)$ :

$$\zeta \approx h(\chi) \gamma(\tau - \chi) - h_{\chi}(\chi) \int_0^{\tau} \gamma(\tau - \chi) d\tau \quad \tau \ll 1 \quad (30)$$

If  $\gamma$  has a sharp front ahead of which the pressure is zero

$$\zeta \approx H(\tau - \chi) \left\{ h(\chi) P^*(\tau - \chi) - h_{\chi}(\chi) \int_0^{\tau - \chi} P^*(z) dz \right\} \quad \tau \ll 1 \quad (31)$$

These expressions are a first approximation only but are useful since  $P^*$  and  $h$  may be quite arbitrary. Improvements of a higher order can be obtained by investigating the full boundary value problem.

**BLANK PAGE**

## 2. STEP-FUNCTION PRESSURE OVER A UNIFORMLY SLOPING BEACH

The simplest model of the pressure assumes a sharp front moving at unit velocity, the pressure being zero ahead and unity behind. In other words

$$\gamma(\chi, \tau) = H(\tau - \chi) = H(\tau - \frac{1}{2}\tau^2) \quad (32)$$

where  $H$  is the Heaviside step function. The sharp front of this model is a realistic representation of the traveling shock, although the pressure behind the shock will actually decay. Such a decaying pressure will be treated in Section 3.

The composite Laplace-Hankel transform of  $\gamma$  is

$$Q(k, s) = \frac{1}{2s^2} \exp\left(-\frac{k^2}{4s}\right) \quad (33)$$

Inserting this expression into Eq. 24 it is found that

$$r_d = 2 \int_0^\infty k J_0(k^2) \frac{1}{2\pi i} \int_{c-i\infty}^{c+i\infty} \frac{\exp\left(s\tau - \frac{k^2}{4s}\right)}{k^2 + 4s^2} ds dk \quad (34)$$

We may evaluate the Laplace inversion integral first and then deal with the Hankel integral. Although the behavior of the Laplace integral for large  $\tau$  can be found by the method of steepest descent, as will be discussed in Section 5, the results are not too significant, physically. Here we shall be concerned with the small time response only.

The response at small  $\tau$  is represented by the transform at large  $s$ . Therefore, we expand the integrand for large  $s$ :

$$I \approx \frac{1}{2\pi i} \int_{c-i\infty}^{c+i\infty} \sum_{n \geq 1} \frac{(-k^2)^{n-1}}{(4s^2)^n} \exp\left(s\tau - \frac{k^2}{4s}\right) ds \quad (35)$$

Each integral in the expansion may be evaluated:

$$I \approx \frac{1}{2} \sum_{n \geq 1} (-1)^{n-1} \frac{\tau^{n-1/2}}{k} J_{2n-1}(k \sqrt{\tau}) \quad (36)$$

so that:

$$\zeta_d \approx \sum_{n \geq 1} (-1)^{n-1} \tau^{n-1/2} \int_0^{\infty} J_0(k^2) J_{2n-1}(k \sqrt{\tau}) dk \quad (37)$$

The integral factor here may be evaluated in terms of Gauss' hypergeometric function:

$$\begin{aligned} \int_0^{\infty} J_0(k^2) J_{2n-1}(k \sqrt{\tau}) dk &= \tau^{-1/2} F\left(n; -n+1, 1, \frac{\chi}{\tau}\right) & \chi < \tau \\ &= 0 & \chi > \tau \end{aligned}$$

which, in turn, may be expressed in terms of Legendre polynomials:

$$\int_0^{\infty} J_0(k^2) J_{2n-1}(k \sqrt{\tau}) dk = H(\tau - \chi) \tau^{-1/2} P_{n-1}\left(1 - 2 \frac{\chi}{\tau}\right) \quad (38)$$

Inserting this result into Eq. 37 gives

$$\begin{aligned} \zeta_d &\approx \sum_{n \geq 0} (-\tau)^n P_n\left(1 - 2 \frac{\chi}{\tau}\right) & \chi < \tau \\ &= 0 & \chi > \tau \end{aligned} \quad (39)$$

Combining this with the static component  $-\gamma = -H(\tau - \chi)$  gives

$$\zeta \approx \left\{ \sum_{n \geq 1} (-\tau)^n P_n\left(1 - 2 \frac{\chi}{\tau}\right) \right\} H(\tau - \chi) \quad \tau \ll 1 \quad (40)$$

This series may be summed explicitly, giving:

$$\begin{aligned} \zeta &\approx (1 + 2\tau + \tau^2 - 4\chi)^{-1/2} - 1 & \chi < \tau \\ &= 0 & \chi > \tau \end{aligned} \quad (41)$$

Since  $\tau$  and  $\chi$  are very small compared to unity, this expression may be approximated as

$$\begin{aligned} \zeta &\approx 2\chi - \tau & \chi < \tau \\ &= 0 & \chi > \tau \end{aligned} \quad (42)$$

which is seen to be the first term of the series in Eq. 40, the succeeding terms being small. As illustrated in Fig. 2, the free surface is deformed only beneath the pressure, having a sharp front at the pressure front.

The mathematical profile OA'CD satisfies conservation of mass. Due to the presence of the bottom, however, the physical system cannot; perhaps the new shoreline at A should be interpreted as a sink-like singular point. Singular behavior at a shoreline has been investigated by Ho and Meyer (1962).

Reverting to physical variables, it is found that the peak elevation,  $\eta_E$ , and the peak depression,  $\eta_D$ , are

$$\begin{aligned} \eta_E &\approx \frac{P_o \alpha t}{\rho U} \\ \eta_D &\approx - \frac{P_o \alpha^2 t}{\rho U(2 + \sigma)} \end{aligned} \quad (43)$$

where  $P_o$  is the magnitude of the pressure step.

This case may be extended to consider a step of finite duration. The pressure may be thought of as a superposition of two step functions:

$$\gamma(\chi, \tau) = H(\tau - \chi) - H(\tau - \tau_o - \chi) \quad (44)$$

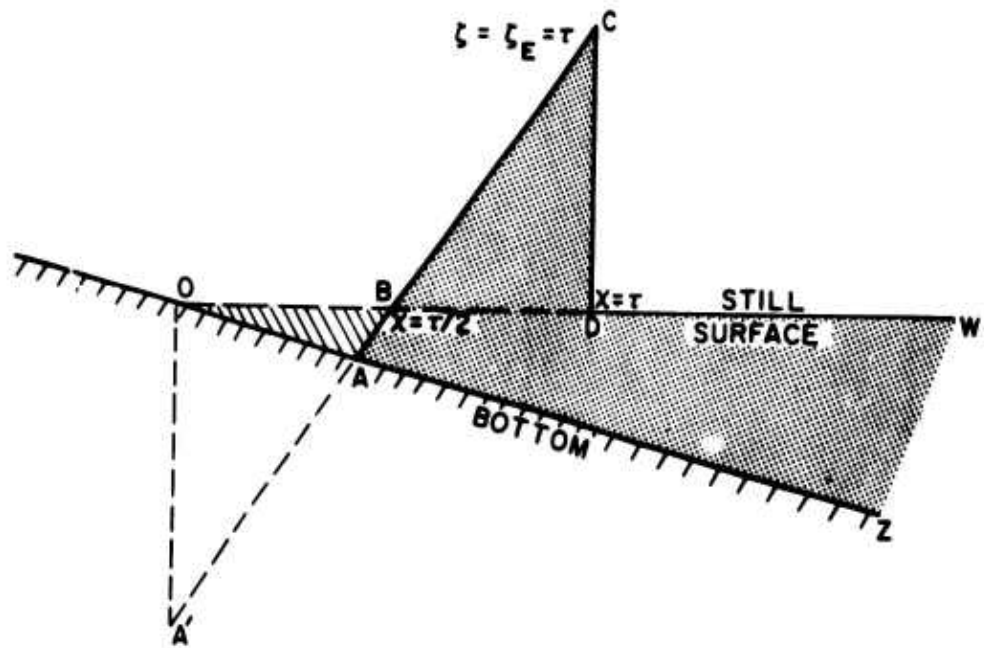

Figure 2  
Step-pressure response

Analysis similar to the foregoing yields the result illustrated in Fig. 3; the length AE depends on  $\tau$  and  $\tau_0$  and is an almost uniform depression. Again, the maximum water elevation is  $\zeta_E = \tau$ .

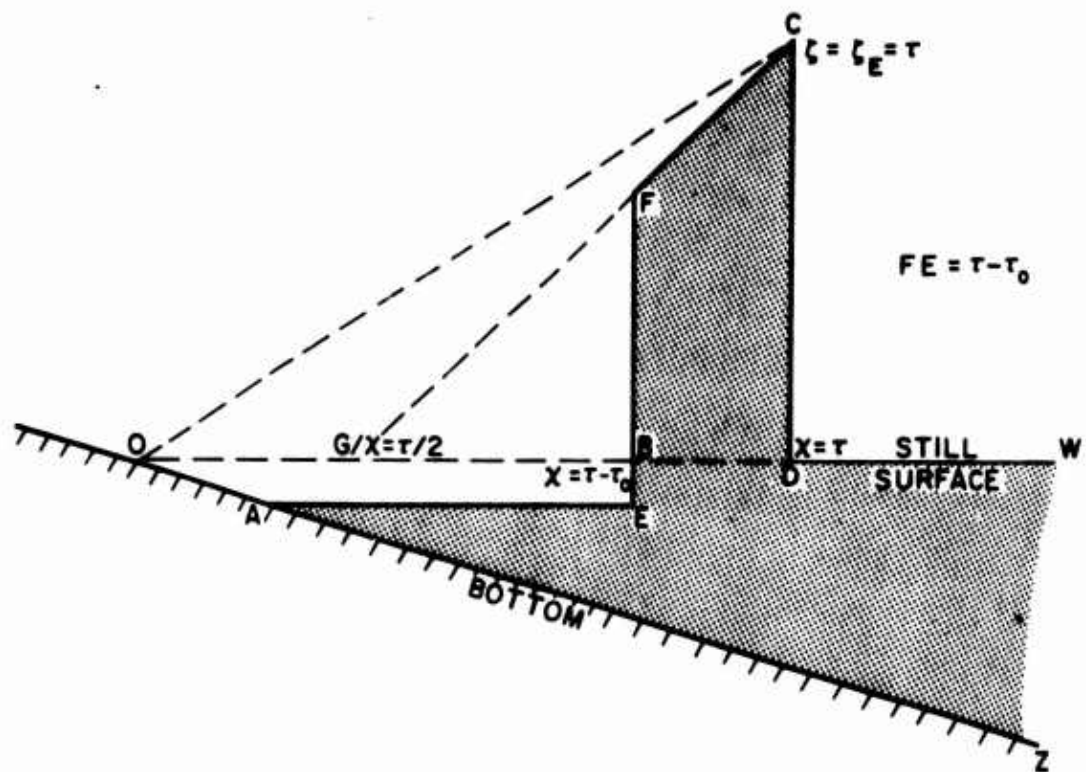

Figure 3  
Finite duration step-pressure response

### 3. DECAYING PRESSURE OVER A UNIFORMLY SLOPING BEACH

In this second model, we assume a pressure distribution that decays behind a sharp front, as:

$$\gamma(\chi, \tau) = H(\tau - \chi) e^{-\beta(\tau - \chi)} \quad (45)$$

Then we have

$$Q(k, s) = \frac{\exp\left(-\frac{k^2}{4s}\right)}{2s(s + \beta)} = \frac{\exp\left(-\frac{k^2}{4s}\right)}{2s^2} \left(1 - \frac{\beta}{s + \beta}\right) \quad (46)$$

The first part of this expression is the same as that of Eq. 33 and so represents the dynamic response of that model, which we may denote by  $\zeta_d^{(1)}$ , enabling us to write

$$\zeta_d = \zeta_d^{(1)} - \beta \int_0^{\tau} \zeta_d^{(1)}(\chi, \tau^*) e^{-\beta(\tau - \tau^*)} d\tau^* \quad (47)$$

by the convolution theorem.

Again concentrating on behavior at initial moments ( $\tau \ll 1$ ) we may use the small-time approximation of  $\zeta_d^{(1)}$ , i. e., Eq. 39 to evaluate the convolution integral:

$$\begin{aligned} & - \beta \int_0^{\tau} \zeta_d^{(1)}(\chi, \tau^*) e^{-\beta(\tau - \tau^*)} d\tau^* \\ & = - \beta H(\tau - \chi) \int_{-\chi}^{\tau} (1 + 2\tau^* + \tau^{*2} - 4\chi)^{-1/2} e^{-\beta(\tau - \tau^*)} d\tau^* \end{aligned}$$

Expanding the radical and neglecting terms above first order (since  $\tau \ll 1$ ) gives

$$\zeta_d = \zeta_d^{(1)} - H(\tau - \chi) \left\{ \left(1 + \frac{1}{\beta}\right) \left(1 - e^{-\beta(\tau - \chi)}\right) + 2\chi - \tau - \chi e^{-\beta(\tau - \chi)} + O(\tau^2) \right\} \quad (48)$$

Introducing  $\zeta_d^{(1)}$  and  $-\gamma$  then yields

$$\zeta = H(\tau - \chi) \left\{ -\frac{1}{R} \left[1 - e^{-\beta(\tau - \chi)}\right] + \chi e^{-\beta(\tau - \chi)} + O(\tau^2) \right\} \quad (49)$$

This response is illustrated in Fig. 4 and may be somewhat more realistic than the previous models. Again, the peak height is  $\zeta = \tau$ .

Reverting to physical variables where  $P_o$  is the peak pressure and  $\beta$  is written as  $T/T_o$ , where  $T_o$  is the time scale of the pressure decay, gives

$$\eta_E \approx \frac{P_o \alpha t}{\rho U} \quad (50)$$

$$\eta_D \approx \frac{P_o \sigma T_o}{\rho U}$$

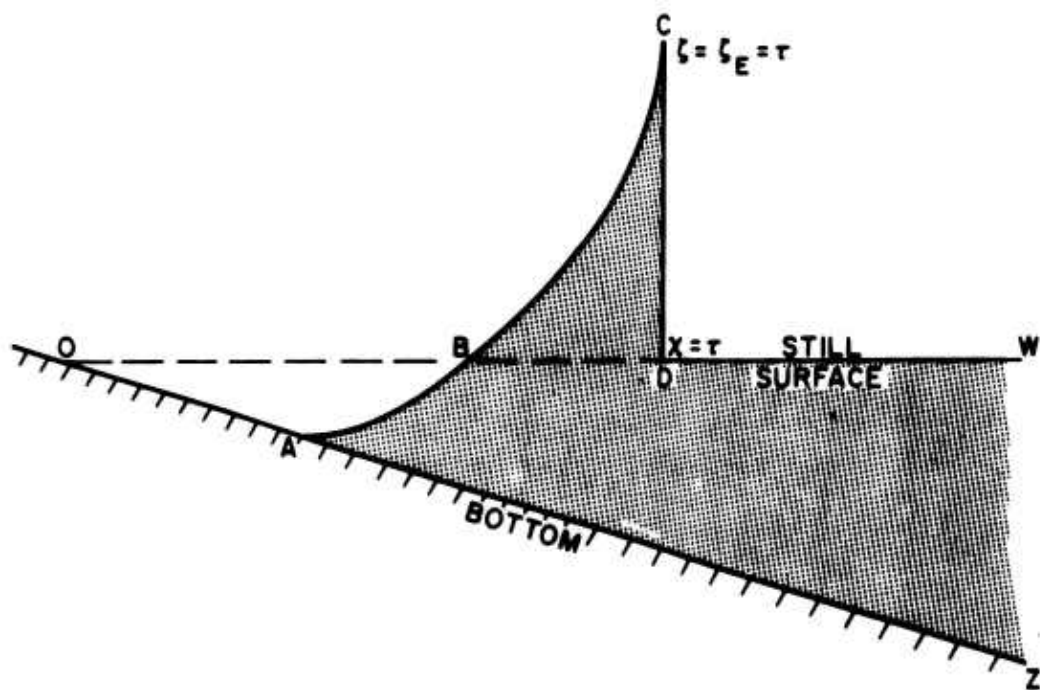

Figure 4  
Decaying pressure response

**BLANK PAGE**

#### 4. THE CASE OF A CONSTANT-DEPTH CHANNEL

The governing equation for the disturbance in a constant-depth channel with a wall at the leading end follows immediately from Eq. 7

$$h \eta_{xx} - \frac{1}{g} \eta_{tt} = - \frac{h}{\rho g} P_{xx} \quad (51)$$

The boundary conditions may be written as

$$\begin{aligned} \eta_x &= 0 & \text{at} & \quad x = 0 & \quad (\because u = \frac{\partial \phi}{\partial x} = 0) \\ \eta &\rightarrow 0 & \text{as} & \quad x \rightarrow \infty & \quad \text{for } t < \infty \end{aligned} \quad (52)$$

while the initial conditions are

$$\eta = 0 = \eta_t \quad \text{at} \quad t = 0 \quad (53)$$

For small time, an approximate result is again found by neglecting gravity forces so that Eq. 51 becomes

$$\eta_{tt} = \frac{h}{\rho} P_{xx} \quad (54)$$

Writing the pressure as

$$P = P(t - \frac{x}{U})$$

gives

$$P_{xx} = \frac{1}{U^2} P_{tt}$$

Letting  $P$  be a step function

$$P = P_0 H(t - \frac{x}{U}) \quad (55)$$

where  $P_0$  is the magnitude of the pressure step, we have

$$P_{xx} = \frac{P_0}{U^2} \delta' \left( t - \frac{x}{U} \right) \quad (56)$$

where  $\delta$  is the delta function. Then it follows that

$$\eta_{tt} = \frac{P_0 h}{\rho U^2} \delta' \left( t - \frac{x}{U} \right) \quad (57)$$

Integrating with respect to  $t$  from 0 to  $t$  and utilizing the initial conditions gives

$$\eta(x, t) = \frac{P_0 h}{\rho U^2} \left\{ H \left( t - \frac{x}{U} \right) - H \left( - \frac{x}{U} \right) - t \delta \left( \frac{x}{U} \right) \right\} \quad (58)$$

On the other hand, if we take  $P$  to be a smooth function, we have

$$\eta_{tt} = \frac{h}{\rho U^2} P_{tt} \quad (59)$$

so that

$$\eta(x, t) = \frac{h}{\rho U^2} \left\{ P(x, t) - P(x, 0) - t P_t(x, 0) \right\} \quad (60)$$

For example, letting  $P$  be given by

$$P = P_0 \operatorname{erfc} \left\{ a \left( \frac{x}{U} - t \right) \right\} \quad (61)$$

where  $\operatorname{erfc}$  denotes the complementary error function, yields

$$\begin{aligned} \eta(x, t) = \frac{P_0 h}{\rho U^2} \left\{ \operatorname{erfc} \left[ a \left( \frac{x}{U} - t \right) \right] - \operatorname{erfc} \left( a \frac{x}{U} \right) \right. \\ \left. - \frac{2a t}{\sqrt{\pi}} \exp \left[ a^2 \left( \frac{x}{U} \right)^2 \right] \right\} \quad (62) \end{aligned}$$

Figure 5 illustrates such a response.

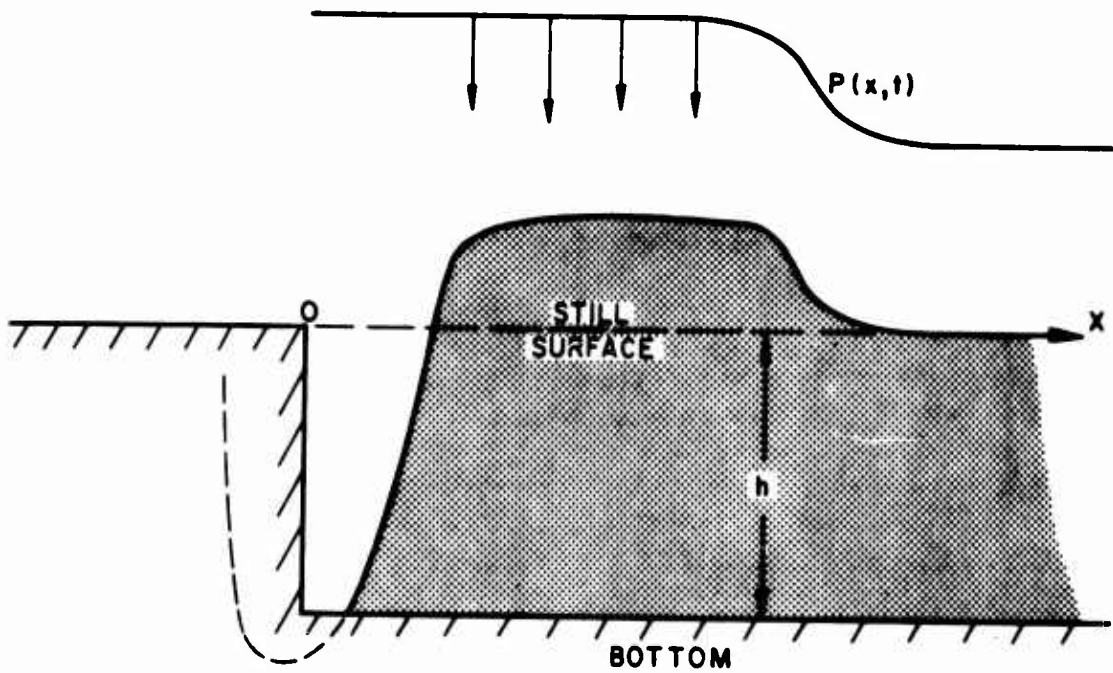

Figure 5  
Response of constant-depth channel

**BLANK PAGE**

## 5. RESPONSE AT LARGE TIME

It is evident that the present model can only poorly describe the large time response since at large time the pressure front will be acting in water which is no longer shallow. Furthermore, as the blast wave progresses, its strength and velocity eventually decrease to those of an acoustic wave, so that our assumptions are invalid. But, still, it is of interest to see what the results are.

Denoting the Laplace inversion integral of Eq. 34 by I and making the change of variable

$$\Delta = S\theta \quad \theta = \sqrt{\tau} \quad (63)$$

we have

$$I = \frac{1}{2\pi i} \left(\frac{\theta}{4}\right) \int_{c-i\infty}^{c+i\infty} \frac{e^{\theta(\Delta - k^2/4\Delta)}}{\Delta^2 + k^2\theta^2/4} d\Delta \quad (64)$$

This is of the form

$$\int_{\Gamma} e^{\theta f(\Delta)} G(\Delta, \theta) d\Delta$$

for which the method of steepest descent is suitable. When  $\theta \gg 1$  ( $\tau \gg 1$ ) one may evaluate the integral approximately by deforming the contour in the  $\Delta$  plane to pass the saddle-points located at

$$\Delta = \frac{ik}{2}, \quad -\frac{ik}{2}$$

The steepest path should be directed at angles  $3\pi/4$  and  $\pi/4$  with the positive real axis in the complex  $\Delta$  plane. Since  $G = (\Delta^2 + k^2\theta^2/4)^{-1}$

has two simple poles at  $\Delta = \pm ik\theta/2$  it is evident that the residues must be accounted for in changing the contour from  $\Gamma$  to  $\Gamma'$  (Fig. 6). Following standard formulas, we have:

$$\begin{aligned}
I &= \frac{1}{2\pi i} \int_{\Gamma} = \frac{1}{2\pi i} \int_{\Gamma'} + \text{Residues} \\
&= I_{\text{saddle points}} + I_{\text{poles}} \\
&\approx \frac{1}{2} \sqrt{\frac{\theta}{\pi}} \frac{k^{-3/2}}{\tau-1} (\cos k\theta - \sin k\theta) \\
&\quad + \frac{1}{2k} \sin\left(\frac{\tau+1}{2} k\right) \quad \tau \gg 1
\end{aligned} \tag{65}$$

Equation 65 may be substituted in Eq. 34 to yield

$$\begin{aligned}
\zeta_d &\approx \frac{\tau^{1/4}}{\tau-1} \frac{1}{\sqrt{\pi}} \int_0^{\infty} (\cos k\theta - \sin k\theta) J_0(k\xi) \frac{dk}{\sqrt{k}} \\
&\quad + \int_0^{\infty} \sin\left(k \frac{\tau+1}{2}\right) J_0(k\xi) dk
\end{aligned} \tag{66}$$

Both integrals in this expression may be explicitly evaluated:

$$\begin{aligned}
(\zeta_d)_{\text{poles}} &= \int_0^{\infty} \sin\left(k \frac{\tau+1}{2}\right) J_0(k\xi) dk \\
&= \left[ \left(\frac{\tau+1}{2}\right)^2 - \chi \right]^{-1/2} \quad \chi < \left(\frac{\tau+1}{2}\right)^2 \\
&= 0 \quad \chi > \left(\frac{\tau+1}{2}\right)^2
\end{aligned} \tag{67}$$

### 3.2 Sample Analysis

The value of a sample is only as good as the water in it can be measured. This measurement is a function of how the water is removed from the sample chamber walls, the instrument used for analysis, and how accurately the instrument is calibrated. Although present procedures may be adequate and possibly even optimum, detailed quantitative investigations of many aspects of the procedures would provide a sounder basis for analysis results and may well show how improvements can be made.

#### 3.2.1 Water Removal

Experiments on the sampler so far have shown that water "sticks" to the sample chamber walls and that heating drives the water off. The more water that sticks to the walls, the more margin for error exists in the analysis results since even small percentage differences in the amount that sticks in the preflight evacuation and the amount that sticks in the postflight analysis might mean large amounts of water. A program to quantitatively determine the effects of the following variables on water retention is proposed.

- a) Materials. Present materials plus any others that a literature survey indicates might be good.
- b) Chamber Temperature
- c) Chamber Pressure
- d) Water Concentration

Suitable chambers of candidate materials would be tested on the presently used mass spectrometer (unless a better instrument is found, as discussed in the following section). Chamber surface area and volume would be comparable to that of an actual sample chamber. Tests would be run at at least three values of each of the other three variables so that

and

$$\begin{aligned}
 (\zeta_d)_{\text{saddle points}} &= H(\chi - \tau) \frac{(\tau/\chi)^{1/4}}{\sqrt{\pi}(\tau - 1)} \\
 &\cdot \left\{ \frac{\Gamma(1/4)}{\sqrt{2}\Gamma(3/4)} F\left(\frac{1}{4}, \frac{1}{4}, \frac{1}{2}, \frac{\tau}{\chi}\right) \right. \\
 &\quad \left. - \frac{\sqrt{2}\Gamma(3/4)}{\Gamma(1/4)} \left(\frac{\tau}{\chi}\right)^{1/2} F\left(\frac{3}{4}, \frac{3}{4}, \frac{3}{2}, \frac{\tau}{\chi}\right) \right\} \quad (68)
 \end{aligned}$$

The complete expression for  $\zeta$  then is

$$\zeta = -\gamma + (\zeta_d)_{\text{saddle points}} + (\zeta_d)_{\text{poles}} \quad (69)$$

Because of the discontinuities, it is convenient to indicate the effective region of each component of this solution in a  $\chi - \tau$  diagram, shown in Fig. 7.

It is seen from Fig. 7 that two fronts exist, one moving with the pressure front as represented by the ray  $\chi = \tau$ , and the other moving with ever increasing speed ahead of the pressure front. The variable speed of the outer front is given by

$$\frac{d\chi}{d\tau} = \frac{\tau + 1}{2} = \sqrt{\chi} \quad (70a)$$

or in physical variables

$$\frac{dx}{dt} = \sqrt{\alpha g x} \quad (70b)$$

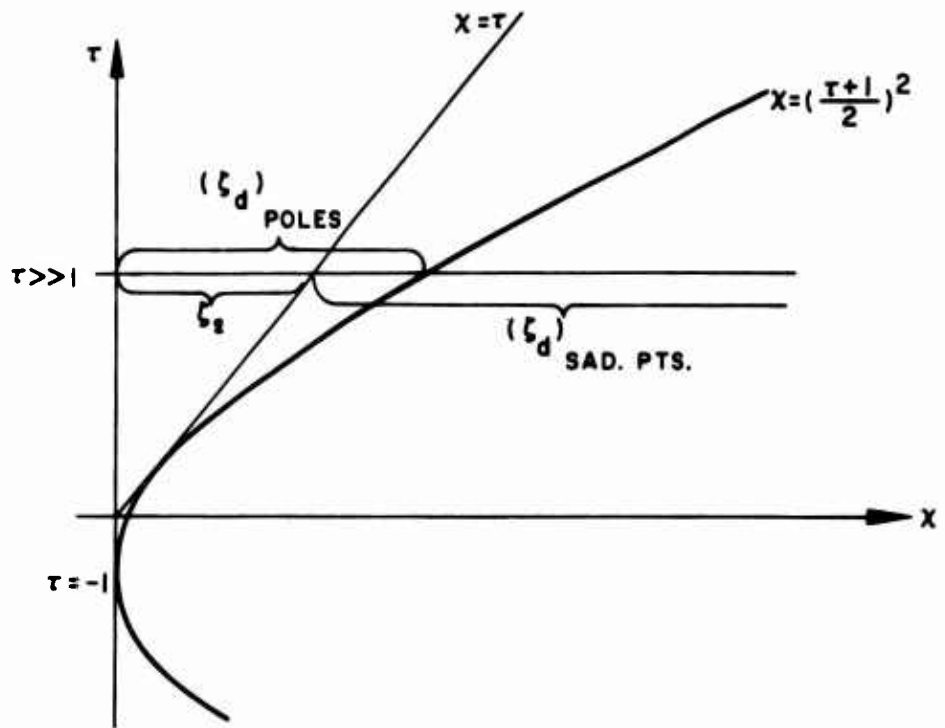

Figure 7  
Regions of solution components

which is precisely the local wave speed  $\sqrt{gh}$  since the depth,  $h$  is  $\alpha x$ . The wave height is infinite there (although integrably singular) and the surface in the neighborhood is essentially given by Eq. 67. Physically, the present model would predict a splash-like wave-front driven forward by the pressure front and traveling at the local wave speed.

The decreasing surface height as  $\chi \rightarrow \infty$  is entirely due to the contribution of the saddle points, Eq. 68. By using the convergent expansion

$$F(a, b, c, z) = 1 + \sum_{n \geq 1} \frac{(a)_n (b)_n}{(c)_n} \frac{z^n}{n!} \quad (71)$$

Eq. 68 becomes

$$(\zeta_d)_{\text{saddle points}} \approx \frac{(\tau/\chi)^{1/4}}{\sqrt{\chi}(\tau-1)} A \left\{ 1 - \frac{1}{A^2} \left( \frac{\tau}{\chi} \right)^{1/2} + O\left( \frac{\tau}{\chi} \right) \right\} \quad (72)$$

where

$$A = \frac{\Gamma(1/4)}{\sqrt{2} \Gamma(3/4)} \quad (73)$$

and  $\tau/\chi$  is small. Near the pressure front,  $\tau/\chi \approx 1$ , the following expansion may be used:

$$F(a, b, a+b, z) = - \frac{\Gamma(a+b)}{\Gamma(a)\Gamma(b)} \sum_{n \geq 0} \frac{(a)_n (b)_n}{(n!)^2} \cdot (1-z)^n \{ \log(1-z) - 2\psi(n+1) + \psi(a+n) + \psi(b+n) \} \quad (74)$$

Then, recalling that  $\psi(1 - m) = \psi(m) + \pi \cot \pi m$ , it is found that at the front,  $\tau/\chi = 1$ ,

$$(\zeta_d)_{\text{saddle points}} = \frac{1}{\tau - 1} \quad (75)$$

Combining these results, one arrives at the sketch shown in Fig. 8.

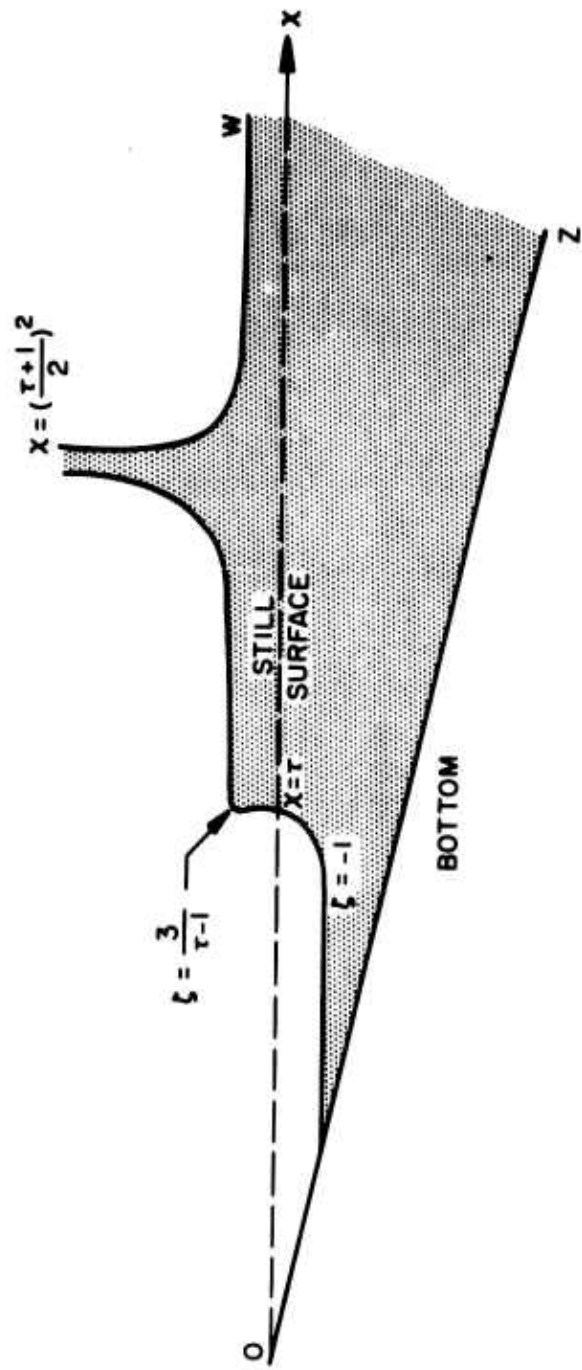

Figure 8  
Large-time response

## 6. DISCUSSION

In this analysis of a blast wave passing a shore two peculiarities arise: 1) the solution is not valid near the shoreline; 2) the free surface rises under a positive pressure. These are related and may be discussed in terms of a constant-depth channel which was treated in Section 4.

First, it is clear that the disturbance must occur wholly beneath the pressure distribution as long as the channel depth is small enough that the wave velocity is less than the pressure velocity. Lamb (1932) found that in the case of an infinitely long channel of depth  $h$ , a distributed pressure traveling at speed  $U$  will result in a surface change in phase with the pressure if  $U < \sqrt{gh}$  and opposite in phase if  $U > \sqrt{gh}$ . This may be seen as follows. Choosing a coordinate system moving with the pressure, one obtains a steady state. From the Bernoulli equation

$$\frac{P(x)}{\rho} + \frac{Q^2}{2gh^2(x)} + h(x) = \text{const}$$

it is found by differentiation that

$$\frac{1}{\rho} \frac{dP}{dx} + \left(1 - \frac{Q^2}{gh^3}\right) \frac{dh}{dx} = 0$$

$$\frac{dh}{dx} = \frac{\frac{1}{\rho} \frac{dP}{dx}}{\left(\frac{U^2}{gh} - 1\right)} \frac{Q}{h} = U$$

Hence,  $dh/dx$  and  $dP/dx$  are of  $\left\{ \begin{array}{l} \text{same} \\ \text{opposite} \end{array} \right\}$  sign if  $U \gtrless \sqrt{gh}$ . It is then easy to see that a positive pressure gives rise to an elevation or a depression according to whether the flow is supercritical or subcritical. Since the flow velocity is just the velocity of the pressure in a stationary coordinate system, we have Lamb's result.

In the present case of a semi-infinite channel, part of the surface is elevated because  $U > \sqrt{gh}$ . However, due to conservation of mass, this fluid must be supplied from behind the pressure front. This is in accordance with the results presented earlier. The same considerations apply to the case of a sloping beach. The immediate neighborhood of the shore deserves further study.

PART II

GROUND WATER TABLE MOTION

## 1. INTRODUCTION

In the event of a nuclear explosion near the ground surface, a cavity would be produced. If the ground water level at the location of the nuclear explosion is relatively high, this would influence the flow of ground water. In particular, radioactive contamination of the ground water basin is possible. Previous investigation into deep-underground explosions indicates that water contamination is of little importance. The same, however, may not be true for a near-surface explosion.

Several problems are postulated within this report. These problems are either completely solved or solved to the point that numerical evaluation becomes straightforward. These problems are:

- a) The filling of a cylindrical crater in an unconfined aquifer.
- b) The filling of a cylindrical crater in an unconfined aquifer near a river.
- c) The discharge of a stream into a large well in a confined aquifer.
- d) A quiescent well in a uniform flow. The advection and diffusion of contaminants initially present in the well are also investigated.
- e) Flow into a water surrounded crater.

PRECEDING  
PAGE BLANK

## 2. THE FILLING OF A CYLINDRICAL CRATER IN AN UNCONFINED AQUIFER

The problem under consideration is the flow of ground water into an empty cylindrical reservoir. The physical occurrence of this problem may be the filling of a cylindrical void excavated by a nuclear explosion. This situation is shown in Fig. 9.

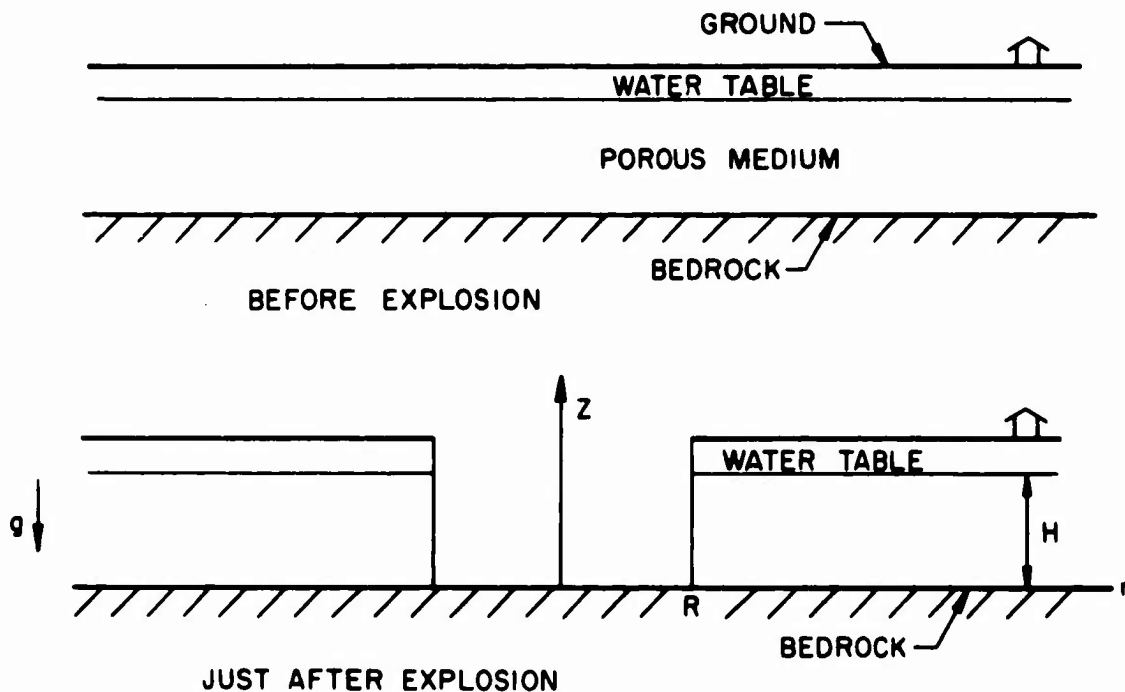

Figure 9

The material within a radius  $R$  of the explosion is assumed completely removed. The water in the ground starts to flow out of the wetted face of the walls of the crater and begins to fill the crater. As time approaches infinity, the crater would be filled with water to the level  $H$ . From the mathematical point of view, this problem is one of unsteady, unconfined flow radially towards a large "well" which is initially empty.

The problem is first formulated by writing down the differential equation and the boundary and initial conditions.

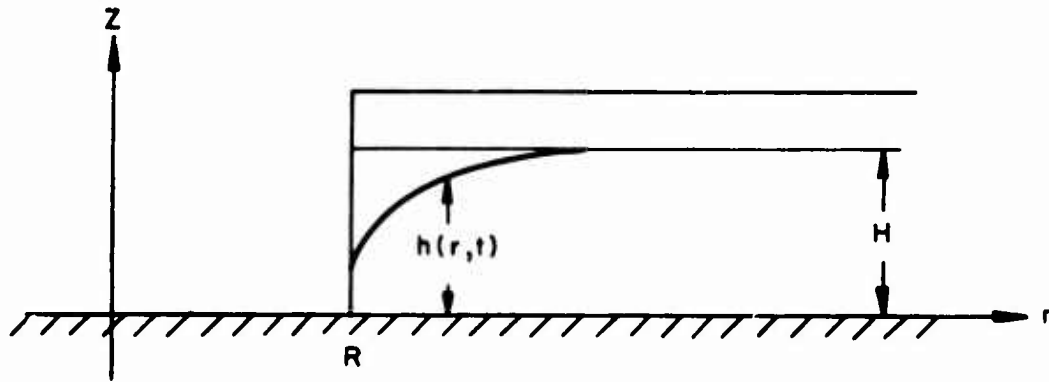

Figure 10

The differential equation is given by combining the equation of continuity

$$\frac{\partial u}{\partial r} + \frac{u}{r} + \frac{\partial w}{\partial z} = 0$$

with Darcy's law

$$\vec{u} = \nabla \phi, \quad \phi = -k [(p/\gamma) + z]$$

where axial symmetry ( $\partial/\partial\theta = 0$ ) has been assumed and

$r$  = radial coordinate

$z$  = vertical coordinate

$u$  = velocity component in the  $r$  direction

$w$  = velocity component in the  $z$  direction

$\vec{u}$  = velocity vector

$\phi$  = velocity potential

$p$  = pressure

$\gamma$  = specific weight

This gives

$$\nabla^2 \phi = 0 = \frac{1}{r} \frac{\partial}{\partial r} \left( r \frac{\partial \phi}{\partial r} \right) + \frac{\partial^2 \phi}{\partial z^2} = 0$$

This equation applies within the flow field which is bounded by the bottom bedrock, the top free surface, the left seepage face, and the height  $H$  at  $r = \infty$  as shown in Fig. 10.

The initial condition is the quiescent state with the free surface given by  $z = H = \text{constant}$  for  $R < r < \infty$ .

The boundary condition at the right side ( $r \rightarrow \infty$ ) is the velocity  $w \rightarrow 0$ . The boundary condition at the bottom is  $w = 0$  ( $z = 0$ ). The boundary condition at the seepage face  $r = R$  ( $0 < z < h_0$ ) is  $p = 0$  which implies  $\phi = -kz$ .

The boundary condition at the free surface  $z = h(r, t)$  is

a) kinematic

$$m \frac{\partial h}{\partial t} + \frac{\partial \phi}{\partial r} \frac{\partial h}{\partial r} - \frac{\partial \phi}{\partial z} = 0$$

b) dynamics

$$\phi = -kz$$

where  $m$  is the porosity.

We now nondimensionalize the variables by the following formulas. The nondimensionalized variables are shown in Fig. 11.

$$h^* = h/H, \quad z^* = z/H, \quad r^* = r/R,$$

$$\varphi^* = \varphi/kH, \quad t^* = \frac{t}{Hm/k}$$

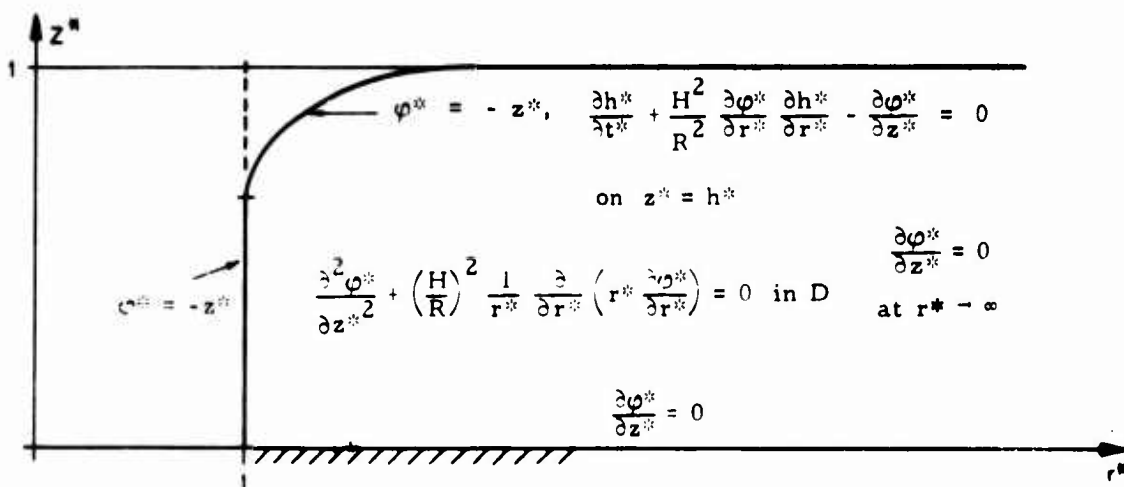

Figure 11

The two boundary conditions on the free surface may be combined. Ignoring the stars, we have

$$\varphi = -h = \varphi(r, z=h(r, t), t) = -h(r, t)$$

Differentiating

$$-\frac{\partial h}{\partial t} = \frac{\partial \varphi}{\partial t} + \frac{\partial \varphi}{\partial z} \frac{\partial h}{\partial t} \Rightarrow \frac{\partial \varphi}{\partial t} = -\frac{\partial h}{\partial t} \left( 1 + \frac{\partial \varphi}{\partial z} \right)$$

$$-\frac{\partial h}{\partial r} = \frac{\partial \phi}{\partial r} + \frac{\partial \phi}{\partial z} \frac{\partial h}{\partial r} \Rightarrow \frac{\partial \phi}{\partial r} = -\frac{\partial h}{\partial r} \left(1 + \frac{\partial h}{\partial z}\right)$$

These may be used to eliminate one of the variables from the  $S_f$  (free surface) conditions.

## 2.1 Method I: Expansion-in-time Series

One of the standard ways of attacking this type of problem (initial boundary problem) is the expansion in powers of  $t$ . Thus, we let

$$\phi(r, z, t) = \phi_0(r, z) + t\phi_1(r, z) + t^2\phi_2 + \dots$$

$$h(r, t) = h_0(r) + th_1(r) + \dots$$

Substituting into the differential equation

$$\frac{\partial^2 \phi_i}{\partial z^2} + \rho^2 \frac{1}{r} \frac{\partial}{\partial r} \left( r \frac{\partial \phi_i}{\partial r} \right) = 0 \quad i = 0, 1, 2, \dots$$

$$\rho = H/R = \text{constant}$$

The boundary conditions are

$$\frac{\partial \phi_i}{\partial z} = 0 \quad r \rightarrow \infty \quad i = 0, 1, 2, \dots$$

$$\frac{\partial \phi_i}{\partial z} = 0 \quad z = 0 \quad i = 0, 1, 2, \dots$$

$$\phi_0 = -z \quad \phi_i = 0 \quad i = 1, 2, \dots \quad \text{on } r = 1, 0 < z < 1$$

$$\phi_0 = -1, \quad \text{on } z = 1 \quad 1 < r < \infty$$

For  $\varphi_i$   $i = 1, 2, \dots$  on  $S_f$ , the condition will have to be derived by substituting the series into the boundary condition. The boundary condition is

$$-\frac{\frac{\partial \varphi}{\partial t}}{1 + \frac{\partial \varphi}{\partial z}} - \rho^2 \frac{\partial \varphi}{\partial r} \frac{\frac{\partial \varphi}{\partial r}}{1 + \frac{\partial \varphi}{\partial z}} - \frac{\partial \varphi}{\partial z} = 0$$

or

$$\frac{\partial \varphi}{\partial t} + \rho^2 \left( \frac{\partial \varphi}{\partial r} \right)^2 + \frac{\partial \varphi}{\partial z} + \left( \frac{\partial \varphi}{\partial z} \right)^2 = 0$$

Substituting the series into the boundary condition,

$$\begin{aligned} \varphi_1 + 2t\varphi_2 + \dots + \rho^2 \left[ \varphi_{0r} + t\varphi_{1r} + \dots \right]^2 + \left[ \varphi_{0z} + t\varphi_{1z} + \dots \right]^2 \\ + \left[ \varphi_{0z} + t\varphi_{1z} + \dots \right]^2 = 0 \end{aligned}$$

Separating the various order of  $t$

$$\varphi_1 = - \left\{ \rho^2 \left( \frac{\partial \varphi_0}{\partial r} \right)^2 + \left( \frac{\partial \varphi_0}{\partial z} \right) + \left( \frac{\partial \varphi_0}{\partial z} \right)^2 \right\} \text{ on } z = 1$$

$$\varphi_2 = - \frac{1}{2} \left\{ \rho^2 \left( 2 \frac{\partial \varphi_0}{\partial r} \frac{\partial \varphi_1}{\partial r} \right) + \frac{\partial \varphi_1}{\partial z} + 2 \frac{\partial \varphi_0}{\partial z} \frac{\partial \varphi_1}{\partial z} \right\}$$

etc.

The advantage of this method is, as is the case with most approximate theories, that the nonlinear system is reduced to a succession of linear problems. The solutions should be valid for a relatively small  $t$ . Remembering that it is the dimensionless time which must be small, it is instructive to observe that

$$t^* = \frac{t}{Hm/k}$$

Typical values of  $H$ ,  $m$ , and  $k$  indicate that, for  $t^* = 0.1$ ,  $t$  is of the order of a day or so. Thus, the small time  $t^*$  solution is not entirely useless. Indeed, the solution  $\varphi_0 + t\varphi_1$  should be good for a period of a week or so after initial blasting.

The problem for  $\varphi_0(r, z)$  is, therefore, as follows (Fig. 12):

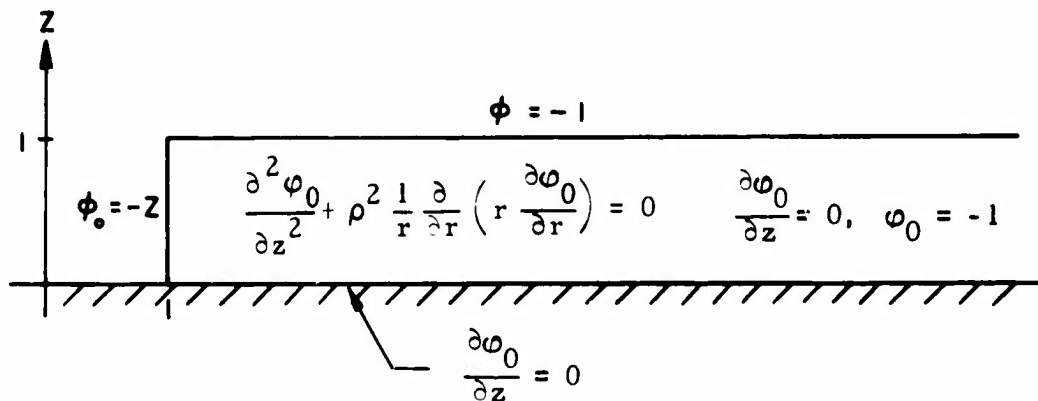

Figure 12

Before attempting a solution, let  $\varphi_0 = -1 + \varphi'_0$  so that the problem in  $\varphi'_0$  is (Fig. 13)

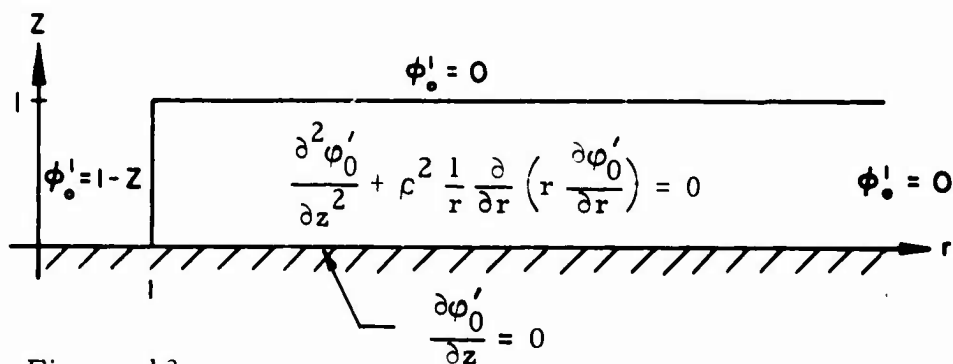

Figure 13

To obtain  $\phi_0'$  we separate variables.

$$\phi_0' = Z(z) R(r) \text{ to obtain}$$

$$\frac{Z'}{Z} = -\rho^2 \frac{1}{rR} \frac{d}{dr} \left( r \frac{dR}{dr} \right) = \text{constant} = -k^2$$

$$Z + k^2 Z = 0 \quad \therefore Z = \begin{cases} \sin kz \\ \cos kz \end{cases}$$

$$\frac{\partial \phi_0'}{\partial z} = 0 \text{ at } z = 0 \quad \therefore Z = A_k \cos kz$$

$$\phi_0 = 0 \text{ at } z = 1 \quad \therefore k = \left(n + \frac{1}{2}\right) \pi, \quad n = 0, 1, 2, \dots$$

The equation in  $R$  is

$$\frac{1}{r} \frac{d}{dr} \left[ r \frac{dR}{dr} \right] - \frac{k^2}{\rho^2} R = 0$$

$$\frac{d^2 R}{dr^2} + \frac{1}{r} \frac{dR}{dr} - (k/\rho)^2 R = 0$$

which gives

$$R = C I_0 \left( \frac{k}{\rho} r \right) + D K_0 \left( \frac{k}{\rho} r \right)$$

where  $I_0$  and  $K_0$  are the modified Bessel functions of the 1<sup>st</sup> and 2<sup>nd</sup> kinds, respectively.

The boundary condition for  $r \rightarrow \infty$  ( $\varphi'_0 \rightarrow 0$ ) then requires  $C = 0$  since

$$I_0(x) \sim \frac{1}{\sqrt{2\pi x}} e^x$$

and

$$K_0(x) \sim \sqrt{\frac{\pi}{2x}} e^{-x}$$

Thus, solution may be expressed

$$\varphi_0 = -1 + \sum_{n=0}^{\infty} A_n K_0 \left( \frac{(n + \frac{1}{2})\pi}{\rho} r \right) \cos \left( n + \frac{1}{2} \right) \pi z$$

It remains to evaluate  $A_n$  which may be obtained by the use of the remaining boundary condition, i. e.,

$$\text{at } r = 1, \quad \varphi_0 = -z$$

$$\therefore \sum_{n=0}^{\infty} A_n K_0 \left( \frac{(n + \frac{1}{2})\pi}{\rho} \right) \cos \left( n + \frac{1}{2} \right) \pi z = 1 - z$$

Let

$$B_n = A_n K_0 \left[ \frac{(n + \frac{1}{2})\pi}{\rho} \right]$$

Then, by Fourier series methods,  $B_n$  is easily found to be

$$\frac{8}{\pi^2 (2n+1)^2}$$

Hence,

$$\varphi_0 = -1 + \sum_{n=0}^{\infty} \frac{8}{\pi^2 (2n+1)^2} \frac{K_0\left(\frac{2n+1}{2} \frac{\pi r}{\rho}\right)}{K_0\left(\frac{2n+1}{2} \frac{\pi}{\rho}\right)} \cos(2n+1) \pi \frac{z}{2}$$

Thus, we now know  $\varphi_0(r, z)$ .

Let

$$f(r) = - \left\{ \rho^2 \left( \frac{\partial \varphi_0}{\partial r} \right)^2 + \left( \frac{\partial \varphi_0}{\partial z} \right)^2 + \frac{\partial \varphi_0}{\partial z} \right\} \Bigg|_{z=1}$$

The problem for  $\varphi_1$  is then (Fig. 14)

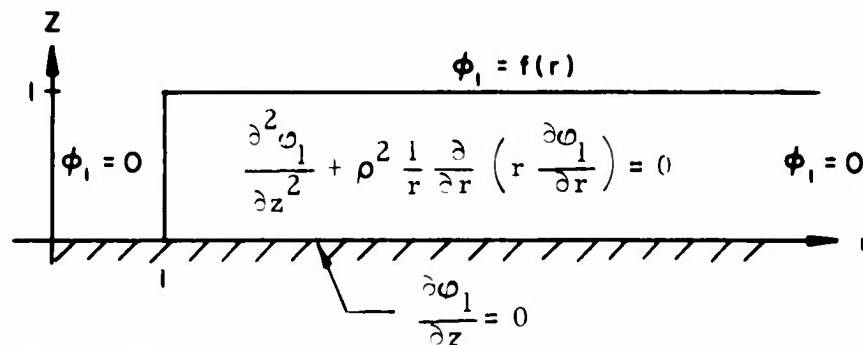

Figure 14

which may be solved by Hankel transform techniques. These will not be performed here.

## 2.2 Method II: Quasi-Steady Solution

The method presented before would yield the exact solution if the series were convergent and if the entire series were found. Practically, this should be convergent for a small enough  $t$  and, for such a small  $t$ , perhaps one or two terms in the series would be sufficient.

Even the first two terms, however, are not easily evaluated numerically, although it can certainly be done. This numerical difficulty would be more severe in the case of  $\phi_1$  than  $\phi_0$ . In other words, even though the method of expansion in powers of  $t$  yields analytical solution in the form of  $\phi_0(r, z)$ ,  $\phi_1(r, z)$ , etc., to obtain numerical results, it is still necessary to do a substantial amount of computational labor. Therefore, it would be desirable to have a simpler solution which would give numerical results without too much work. This would, of course, have to be a more approximate theory. Such a theory is presented. This theory is based on the assumption of quasi-steady motion and the Dupuit-Forscheimer approximation.

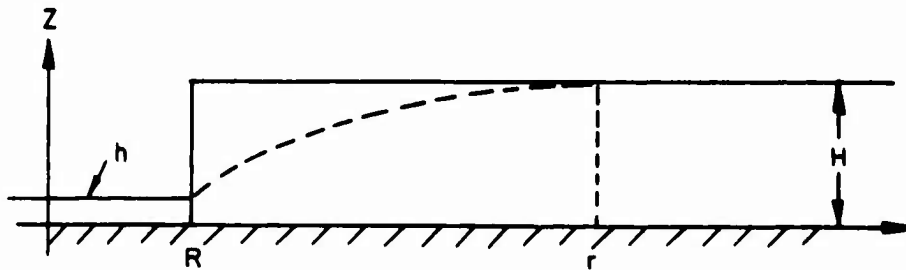

Figure 15

Let  $Q(t)$  = the discharge through the sides  
 $h(t)$  = the height of water in the crater  
 $H$  = the height of water in the porous medium for  $r \rightarrow \infty$

At a given instant of time, it can be assumed that the motion is given by the Dupuit-Forscheimer solution. With this assumption,

$$H^2 - h^2 = \frac{Q}{\pi K} \log r/R \quad (1)$$

where  $K$  is the permeability, and  $r$  is the radial distance representing the intersection of the Dupuit free surface with  $z = H$ .

There are now three unknowns  $h(t)$ ,  $Q(t)$  and  $r(t)$ . Therefore, two more equations are needed. One of them is obviously

$$\int_0^t Q(\tau) d\tau = \pi R^2 h$$

or

$$Q = \pi R^2 \frac{dh}{dt} \quad (2)$$

The second one is not so easily found. One way is that the volume of water in the reservoir should come out of the voids of the dewatered region. That is

$$\pi R^2 h = \epsilon \int_R^{r'} 2\pi \rho s(\rho) d\rho \quad (3)$$

where  $s$  is the drawdown as illustrated in Fig. 8 and is given by the Dupuit formula

$$s(\rho) = H - \sqrt{H^2 - \frac{Q}{\pi K} \log \frac{\rho}{R}}$$

and  $\epsilon$  is the porosity.

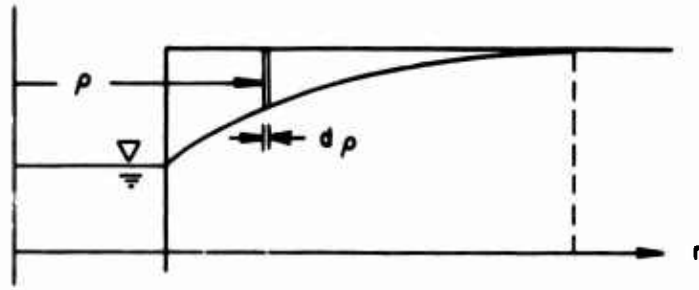

Figure 16

Before attempting a solution, nondimensionalize by the following variables

$$r^* = r/R, \quad h^* = h/H, \quad Q^* = Q/\pi KH^2, \quad t^* = \frac{t}{R^2/HK}$$

Then

$$1 - h^{*2} = Q^* \log r^*$$

$$Q^* = \frac{dh^*}{dt^*}$$

$$\begin{aligned} h^* &= 2\epsilon \int_1^{r^*} \rho (1 - \sqrt{1 - Q^* \log \rho}) d\rho \\ &= 2\epsilon \left[ \frac{r^{*2}}{2} - \frac{1}{2} \right] - 2\epsilon \int_1^{r^*} \rho \sqrt{1 - Q^* \log \rho} d\rho \\ &= \epsilon (r^{*2} - 1) - 2\epsilon \int_1^{r^*} \rho \sqrt{1 - Q^* \log \rho} d\rho \end{aligned}$$

Dropping stars,

$$1 - h^2 = \frac{dh}{dt} \log r$$

$$h = \epsilon (r^2 - 1) - 2\epsilon \int_1^r \rho \sqrt{1 - \frac{dh}{dt} \log \rho} \, d\rho$$

This is a system of nonlinear integro-differential equations. First examine the integral

$$I = \int \rho \sqrt{1 - Q \log \rho} \, d\rho$$

Let

$$\rho = e^y \quad d\rho = e^y \, dy$$

then

$$I = \int e^{2y} \sqrt{1 - Qy} \, dy$$

Now let

$$z = 1 - Qy, \quad y = (1 - z)/Q, \quad dy = -dz/Q$$

$$I = - \int \exp \left[ \frac{2}{Q} (1 - z) \right] \sqrt{z} \frac{dz}{Q} = \frac{-e^{2/Q}}{Q} \int \exp \left( -\frac{2}{Q} z \right) \sqrt{z} \, dz$$

Let

$$w = \frac{2}{Q} z, \quad dz = \frac{Q}{2} \, dw, \quad w = x^2$$

$$I = - \frac{1}{Q} e^{2/Q} \left( \frac{Q}{2} \right)^{3/2} \int e^{-w} \sqrt{w} \, dw$$

$$= - \frac{e^{2/Q}}{Q} \left( \frac{Q}{2} \right)^{3/2} \frac{1}{2} \int e^{-x^2} x^2 \, dx$$

The integral  $\int e^{-x^2} x^2 dx$  may be integrated by parts to give

$$\int e^{-x^2} x^2 dx = \int (x/2) e^{-x^2} 2x dx = \frac{x}{2} e^{-x^2} - \frac{1}{2} \int e^{-x^2} dx$$

The original integral  $I$  is evaluated between the limits  $r$  and  $1$ . The relationship between  $x$  and  $\rho$  (after tracing through all the changes of variables) is

$$x = \sqrt{w} = \sqrt{2/Q} \sqrt{z} = \sqrt{2/Q} \sqrt{1 - Qy} = \sqrt{2/Q} \sqrt{1 - Q \log \rho}$$

Hence

$$\begin{aligned} I &= \int_1^r \rho \sqrt{1 - Q \log \rho} d\rho \\ &= \frac{x}{2} e^{-x^2} \left[ \frac{\sqrt{\frac{2}{Q}} \sqrt{1 - Q \log r}}{\sqrt{\frac{2}{Q}} \sqrt{1 - Q \log 1}} - \frac{1}{2} \frac{\sqrt{2/Q} \sqrt{1 - Q \log r}}{\sqrt{2/Q}} e^{-x^2} dx \right] \\ &= \sqrt{\frac{1 - Q \log r}{2Q}} \exp \left[ -\frac{2(1 - Q \log r)}{Q} \right] - \frac{1}{\sqrt{2Q}} e^{-2/Q} \\ &\quad - \frac{1}{2} \left\{ (\sqrt{2/Q} \sqrt{1 - Q \log r}) F - (\sqrt{2/Q}) F \right\} \end{aligned}$$

where  $F(x) = \int_0^x e^{-t^2} dt$

To recapitulate, one has

$$1 - h^2 = Q \log r$$

$$Q = dh/dt$$

$$h = \epsilon (r^2 - 1) - \epsilon \left\{ \sqrt{\frac{2 - 2Q \log r}{Q}} \exp \left[ -\frac{(2 - 2Q \log r)}{Q} \right] \right. \\ \left. - \sqrt{2/Q} e^{-2/Q} - \left[ \left( \sqrt{\frac{2 - 2Q \log r}{Q}} \right) F \right. \right. \\ \left. \left. - (\sqrt{2/Q}) F \right] \right\}$$

to be solved.

Now consider the function in the brackets for the expression in h.

$$F = \sqrt{\frac{2 - 2Q \log r}{Q}} \exp \left( -\frac{2 - 2Q \log r}{Q} \right) - \sqrt{2/Q} e^{-2/Q} \\ - \left( \sqrt{\frac{2 - 2Q \log r}{Q}} \right) F + (\sqrt{2/Q}) F$$

$$\sqrt{\frac{2 - 2Q \log r}{Q}} = \sqrt{2/Q} \sqrt{1 - Q \log r}$$

so that the expression E may be rewritten

$$\sqrt{2/Q} \sqrt{1 - Q \log r} \exp \left[ -\frac{2}{Q} (1 - Q \log r) \right] - \sqrt{2/Q} e^{-2/Q} \\ - \left( \sqrt{2/Q} \sqrt{1 - Q \log r} \right) F + (\sqrt{2/Q}) F \\ = \sqrt{2/Q} e^{-2/Q} \left\{ \sqrt{1 - Q \log r} e^{2 \log r} - 1 \right\} \\ - \left( \sqrt{2/Q} \sqrt{1 - Q \log r} \right) F + (\sqrt{2/Q}) F$$

$$= \sqrt{2/Q} e^{-2/Q} \left\{ \sqrt{1 - Q \log r} r^2 - 1 \right\} \\ - (\sqrt{2/Q} \sqrt{1 - Q \log r}) F + (\sqrt{2/Q}) F$$

The system of nonlinear integro-differential equations can be solved, and the three functions  $Q(t)$ ,  $h(t)$  and  $r(t)$  may be obtained. This involves some numerical computation; however, the amount of computation should be much less than the computation for  $\varphi_0$  and  $\varphi_1$ , etc. of the first method.

Another method will be presented which is not based on Eq. 3 but is based on the formula

$$r = R + 1.5 \sqrt{\nu t} \quad (3a)$$

or

$$r^* = 1 + \frac{1.5 \sqrt{\nu}}{R} \sqrt{\frac{R^2}{HK}} \sqrt{t^*} = 1 + 1.5 \sqrt{\nu/HK} \sqrt{t^*}$$

where  $\nu = K\bar{b}/\epsilon$ .  $\bar{b}$  is a weighted average of the depth of the flow which may, for all practical purposes, be taken as equal to  $H_0$ .

Letting  $1.5 \sqrt{\nu/HK} = \beta$ , we have (dropping stars),

$$r = 1 + \beta \sqrt{t} \quad (3b)$$

Equation 3a simply states that the zone of influence of the draining crater spreads at a rate proportional to  $\sqrt{t}$  (which is normal for diffusion-type phenomena) with a proportionality constant equal to  $1.5\sqrt{\nu}$ . This latter constant is based on observations of discharging wells, Hantush (1965).

The other two equations, of course, remain unchanged and are

$$1 - h^2 = Q \log r$$

$$Q = dh/dt$$

repeating Eq. 3b,

$$r = 1 + \beta\sqrt{t}$$

These combine easily to give

$$1 - h^2 = dh/dt \log (1 + \beta\sqrt{t})$$

which may be written

$$\frac{dh}{1 - h^2} = \frac{dt}{\log (1 + \beta\sqrt{t})}$$

The LHS is

$$\frac{1}{2} \left( \frac{1}{1 - h} + \frac{1}{1 + h} \right) dh$$

which integrates to

$$-\frac{1}{2} \log (1 - h) + \frac{1}{2} \log (1 + h) = \log \left( \frac{1 + h}{1 - h} \right)^{1/2}$$

The RHS is, letting  $t = w^2$ ,  $w' = \beta w$ ,  $z = 1 + w'$  successively

$$\begin{aligned} \frac{2w dw}{\log(1 + \beta w)} &= \frac{2}{\beta^2} \frac{w' dw'}{\log(1 + w')} = \frac{2}{\beta^2} \frac{(z - 1) dz}{\log z} \\ &= \frac{2}{\beta^2} \left[ \frac{z dz}{\log z} - \frac{dz}{\log z} \right] \\ &= \frac{2}{\beta^2} \left[ \frac{d(z^2)}{\log z^2} - \frac{dz}{\log z} \right] \end{aligned}$$

Now

$$\int \frac{dx}{\log x} = \log |\log x| + \log x + \frac{(\log x)^2}{2! \cdot 2} + \frac{(\log x)^3}{3! \cdot 3} + \dots$$

Hence,  $h(t)$  is given implicitly by the relation

$$\begin{aligned} \log \left\{ \frac{1+h}{1-h} \right\}^{1/2} &= \log |\log(1 + \beta \sqrt{t})^2| - \log |\log(1 + \beta \sqrt{t})| \\ &+ \log(1 + \beta \sqrt{t})^2 - \log(1 + \beta \sqrt{t}) \\ &+ \frac{1}{2! \cdot 2} \left\{ (\log(1 + \beta \sqrt{t})^2)^2 - [\log(1 + \beta \sqrt{t})]^2 \right\} \\ &+ \dots \end{aligned}$$

or

$$\left( \frac{1+h}{1-h} \right)^{1/2} = \exp \left( f(x^2) - f(x) \right) \quad f(x) = \int_1^x \frac{dx}{\log x}$$

where  $x = 1 + \beta \sqrt{t}$ .

Let

$$\frac{1+h}{1-h} = \exp \left( 2 [f(x^2) - f(x)] \right) = F(x)$$

one has

$$h = \frac{F - 1}{F + 1}$$

The function  $F(x)$  and, hence,  $h(x)$  may be evaluated simply by means of the digital computer. It should look like the curve shown in Fig. 9.

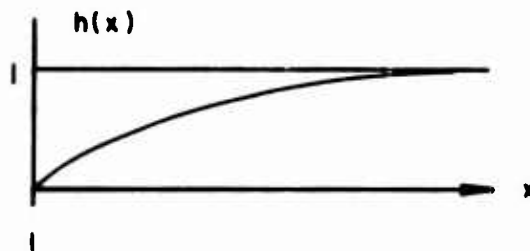

Figure 17

The function  $h(x)$  is

$$h(x) = \frac{e^{g(x)} - 1}{e^{g(x)} + 1}$$

where

$$g(x) = \int_x^{x^2} \frac{d\xi}{\log \xi}$$

This is the same as

$$\begin{aligned} g(x) &= \int_{\log x}^{\log x^2} \frac{e^y dy}{y} = \text{Ei}(\log x^2) - \text{Ei}(\log x) \\ &= \text{Ei}(2 \log x) - \text{Ei}(\log x) \\ &= \text{Ei}(2\ell) - \text{Ei}(\ell) \end{aligned}$$

where  $\ell = \log x$

Thus,

$$h(\log x) = h(\ell) = \frac{e^{g(\ell)} - 1}{e^{g(\ell)} + 1} = \tanh \left[ \frac{1}{2} (\text{Ei}(2\ell) - \text{Ei}(\ell)) \right]$$

$$\ell = \log(1 + \beta \sqrt{t})$$

$h(\ell)$  is evaluated in the range  $0 \leq \ell \leq 2$  and this is shown graphically in Fig. 10. It can be seen that this last method gives a filling time which depends only on the quantity  $R^2/\nu$ . The accuracy of the result depends on the formula  $r = R + 1.5 \sqrt{\nu t}$ .

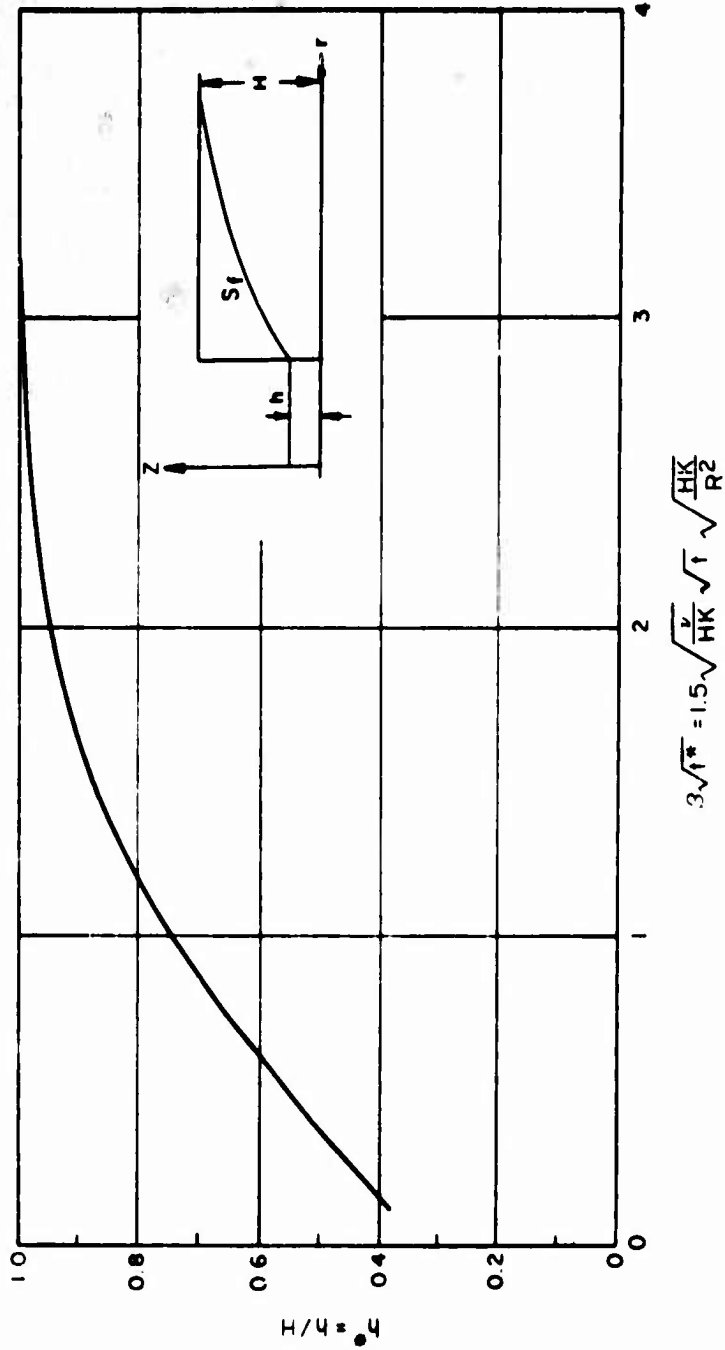

Figure 18

$$h^* (\beta \sqrt{t^{**}}) = \tanh \left\{ \frac{1}{2} \left[ \text{Ei} \left( 2 \log (1 + \beta \sqrt{t^{**}}) \right) - \text{Ei} \left( \log (1 + \beta \sqrt{t^{**}}) \right) \right] \right\}$$

### 3. THE FILLING OF A CRATER NEAR A RIVER IN AN UNCONFINED AQUIFER

The problem of the flow of ground water into an empty cylindrical crater in a medium with infinite extent has been considered in Section 2 and is relatively simple, due to circular symmetry. In the case of a crater located near a river or a lake, such as Detroit, the problem becomes rather complicated due to its nonsymmetry. An exact solution involves a considerable amount of computer calculation which is beyond the time limit. In order to obtain the numerical results, approximate solutions are given. These approximate solutions are based on some assumptions, in particular the Dupuit-Forscheimer assumption, as has been discussed in the previous sections.

Figure 19 indicates the general configuration of the problem. The elevation of the water along the river is assumed to be constant. That is to say the fluctuations of water level of the river are neglected. The mathematical formulation of the problem is similar to the problem indicated in Section 2 except along the river where  $\phi = k(p/r + z)$  is constant. The differential equation and boundary conditions can be written as follows:

The differential equation

$$\nabla^2 \phi = 0$$

The boundary conditions at the free surface are the same as in the case of an infinite aquifer, that is

a) Kinematic

$$m \frac{\partial h}{\partial t} + \frac{\partial \phi}{\partial r} \frac{\partial h}{\partial r} - \frac{\partial \phi}{\partial z} = 0$$

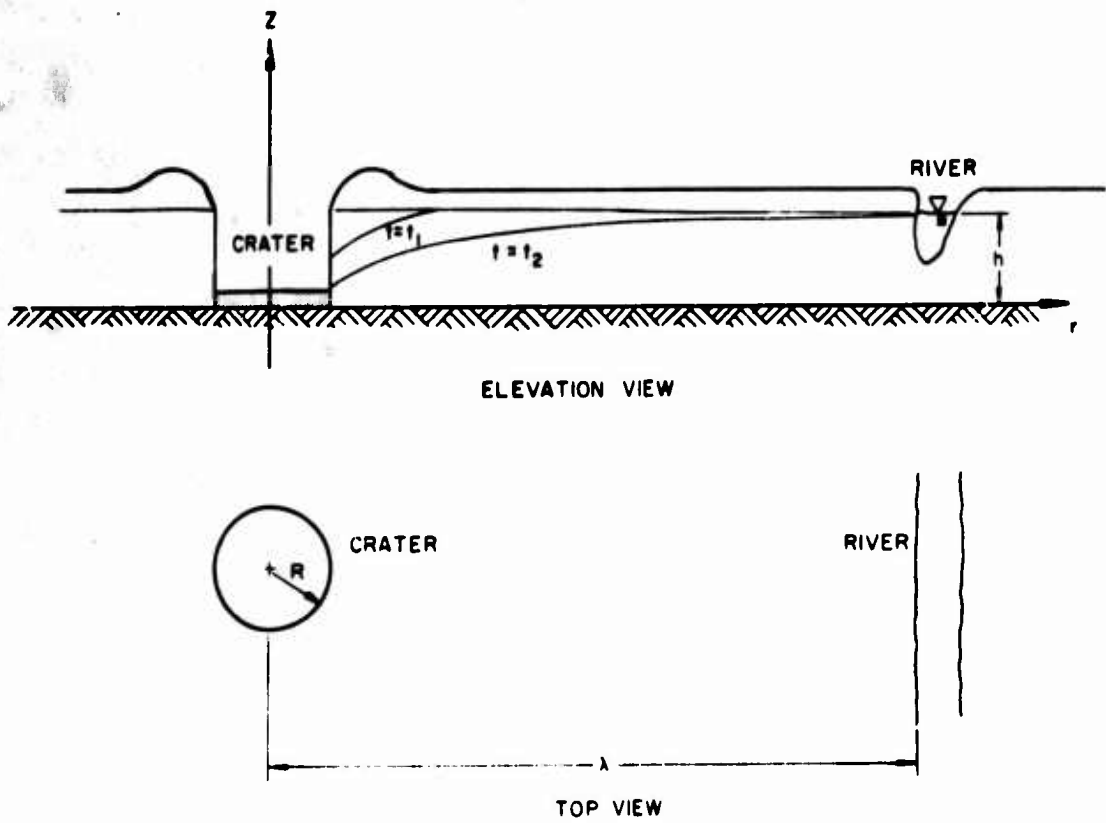

Figure 19

b) Dynamic

$$\phi = - kz$$

The boundary condition along the river is  $\phi = - kH$ .

The notations are as defined in the previous sections except  $\lambda$  which is the distance between the crater and the river.

One of the methods of solution to this problem is to use the method of images. On the opposite side of the river, as shown in Fig. 20, one introduces a recharge crater, with the recharge strength equal to the flow strength of the crater. One obtains the solution for each individual crater by use of power series as has been done in the previous section.

Since the equation of the velocity potential for different order is linear, we may superpose the solution of two individual craters and obtain the resultant solution which satisfies the boundary condition along the river. As has been demonstrated in the previous sections, the calculation of the numerical solution of one crater by use of power series expansion is quite laborious. Therefore, in the following section, an approximate solution is given from which numerical results may be calculated without too much work.

It is clear that the solution of this problem can be divided into two stages. Stage 1, when the radius of influence zone,  $r$ , is less than the distance between crater and river,  $\lambda$ . In this stage, the problem can be considered as if the river were not present. The solution has been obtained in the previous section. Stage 2, when the radius of influence zone,  $r$ , is greater than  $\lambda$ . In this stage, the river begins to effect the motion of the ground water. However, in this stage the gradient of the velocity potential  $\phi$  becomes smaller (the gradient of velocity potential is maximum at initial instants and near the crater). The assumption of small drawdown may be used.

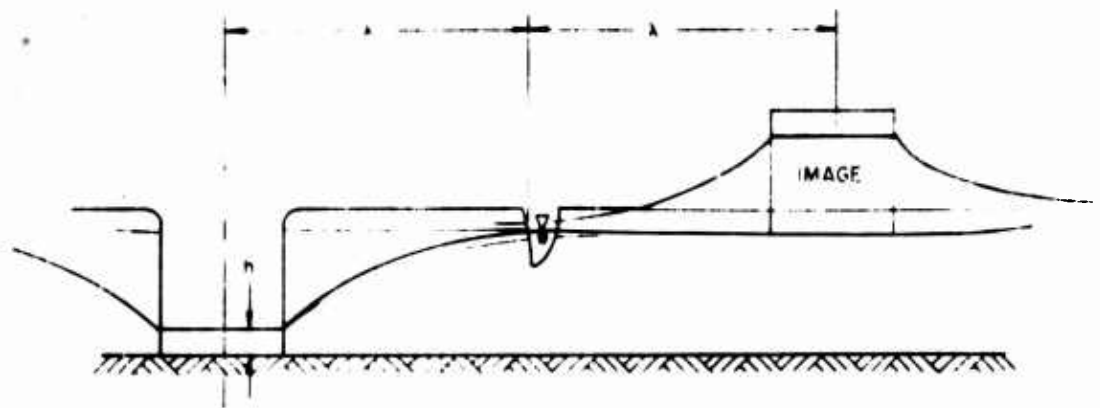

Figure 20

As the drawdown becomes smaller the discharge in a column of unit width,  $\bar{q}$ , may be approximated as

$$\bar{q} = -k\bar{H}\nabla h$$

where  $\bar{H}$  is average depth of the aquifer. Substituting this equation into the unsteady continuity equation

$$\nabla \cdot \bar{q} = \epsilon \frac{\partial h}{\partial t}$$

where  $\epsilon$  is the porosity gives

$$\nabla^2 h = \frac{\epsilon}{k\bar{H}} \frac{\partial h}{\partial t}$$

This is the usual heat equation. Since the equation is linear, one could also use the superposition method to satisfy the boundary condition along the river.

Writing the Laplace equation in cylindrical coordinates one has

$$\frac{\partial^2 h}{\partial r^2} + \frac{1}{r} \frac{\partial h}{\partial r} = \frac{\epsilon}{KH} \frac{\partial h}{\partial t}$$

The solution to this equation with the boundary and initial conditions prescribed in Section 2 is

$$\begin{aligned} h &= H_0 - \frac{Q}{4\pi K\bar{H}} \int_0^\infty \frac{r^2 \epsilon}{4\pi\bar{H}t} \frac{e^{-u}}{u} du \\ &= H_0 - \frac{Q}{4\pi K\bar{H}} \left[ -E_1(-x) \right] \end{aligned}$$

where

$$x = \frac{r^2 \epsilon}{4K\bar{H}t}$$

The drawdown is

$$H_0 - h = \frac{Q}{4\pi K\bar{H}} \left[ -E_i(-x) \right]$$

Superposing two craters in space as indicated in Fig. 21 one has

$$H_0 - h = \frac{Q}{4\pi K\bar{H}} \left[ E_i \left( -\frac{r_1^2 \epsilon}{4K\bar{H}t} \right) + E_i \left( -\frac{r_2^2 \epsilon}{4K\bar{H}t} \right) \right]$$

where  $r_1$  and  $r_2$  are distances from crater and image crater, respectively. They are equal to

$$r_1^2 = (x - \lambda)^2 + y^2$$

$$r_2^2 = (x + \lambda)^2 + y^2$$

in a rectangular system.

The equation governing the filling of the crater is

$$Q = \pi R^2 \frac{dh}{dt}$$

Substituting into the previous equation we have

$$\frac{dh}{dt} = \frac{4\bar{H}K(H_0 - h)}{R^2 \left[ E_i \left( -\frac{r_1^2 \epsilon}{4K\bar{H}t} \right) + E_i \left( -\frac{r_2^2 \epsilon}{4K\bar{H}t} \right) \right]}$$

After integrating, we obtain

$$\log (H_0 - h) = \frac{4 \bar{H} K t}{R^2 \left[ E_i \left( -\frac{r_1^2 \epsilon}{4K\bar{H}t} \right) + E_i \left( -\frac{r_2^2 \epsilon}{4K\bar{H}t} \right) \right]} + c$$

Using the initial condition  $t = 0, h = 0$ , we have  $c = \log H_0$

therefore

$$\frac{h}{H_0} = 1 - \exp \frac{4 \bar{H} K t}{R^2 \left[ E_i \left( -\frac{r_1^2 \epsilon}{4K\bar{H}t} \right) + E_i \left( -\frac{r_2^2 \epsilon}{4K\bar{H}t} \right) \right]}$$

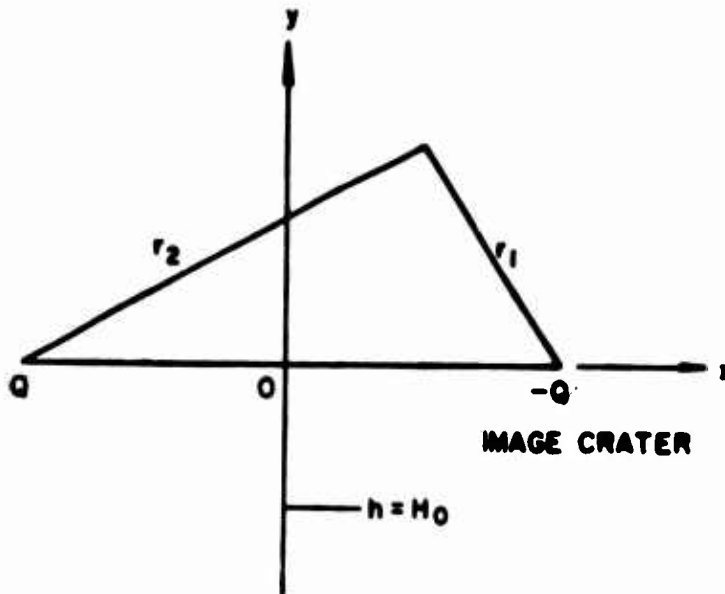

PA-3-9073

Figure 21

**BLANK PAGE**

#### 4. DISCHARGE OF STREAM INTO A LARGE WELL IN A CONFINED AQUIFER

In the case where the explosion has created a cavity near a stream and the aquifer under consideration is confined, the solution of the problem of filling the cavity may be rather simply found with the notation shown in Fig. 22.

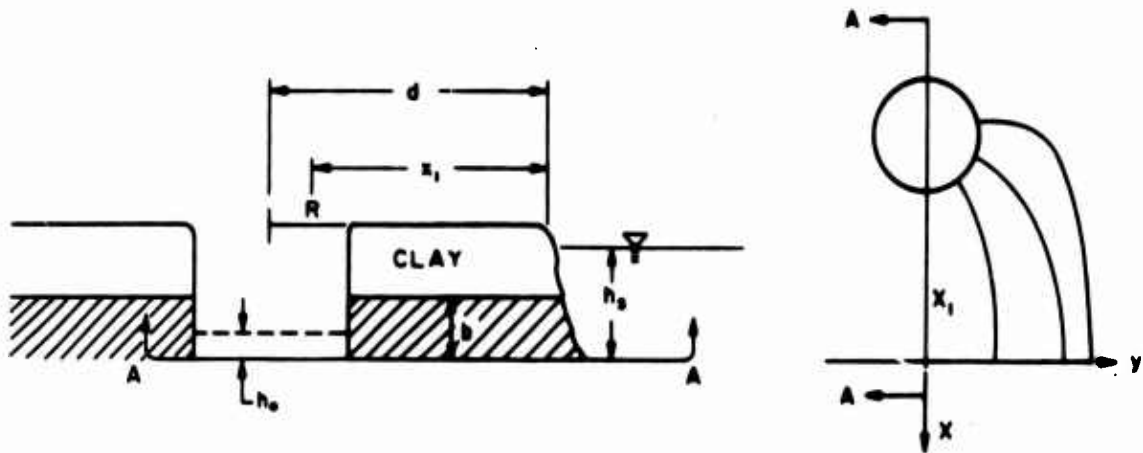

Figure 22

- where
- $b$  = the thickness of the aquifer
  - $x_1$  = distance from origin to center of point well
  - $h_0$  = water level in well
  - $h_s$  = water level in stream
  - $d$  = distance from center of real well to stream
  - $R$  = radius of well
  - $x$  = coordinate
  - $y$  = coordinate

The solution may be written as

$$h_s - h = \frac{Q}{4\pi T} \ln \frac{(x - x_1)^2 + y^2}{(x + x_1)^2 + y^2}$$

where

Q = discharge

T = hydraulic transmissivity = Kb

K = permeability

This is the solution for a point well at  $x = x_1$ ,  $y = 0$  with a stream of head  $h_s$  along  $x = 0$ . The distance  $d$  and the well radius  $R$  are as yet unspecified.

For a finite diameter well, any equipotential may be taken as a well cross section. Thus, if  $h_w$  is the level of water in the well, then along the well edges

$$h_s - h_w = \frac{Q}{4\pi T} \ln \frac{(x - x_1)^2 + y^2}{(x + x_1)^2 + y^2}$$

and

$$\frac{(x - x_1)^2 + y^2}{(x + x_1)^2 + y^2} = \exp \left[ \frac{4\pi T}{Q} (h_s - h_w) \right] = \alpha$$

This is the equation of a circle (the well edge).

$$(x - x_1)^2 + y^2 = \alpha (x + x_1)^2 + \alpha y^2$$

or

$$x^2 - \frac{1 + \alpha}{1 - \alpha} 2x_1 x + x_1^2 + y^2 = 0$$

$$x^2 - 2 \left( x_1 \frac{1 + \alpha}{1 - \alpha} \right) x + \left( x_1 \frac{1 + \alpha}{1 - \alpha} \right)^2 + x_1^2 - \left( x_1 \frac{1 + \alpha}{1 - \alpha} \right)^2 + y^2 = 0$$

or

$$\left( x - x_1 \frac{1 + \alpha}{1 - \alpha} \right)^2 + y^2 = x_1^2 \left( \frac{1 + \alpha}{1 - \alpha} \right)^2 - x_1^2$$

Thus, the center is at  $x = x_1 \frac{1 + \alpha}{1 - \alpha}$ , and the radius is  $x_1 \sqrt{\left( \frac{1 + \alpha}{1 - \alpha} \right)^2 - 1} = R$ .

This solution may be easily adapted to a finite circular well at a distance  $d$  from the stream. The center is at

$$x_1 \frac{1 + \alpha}{1 - \alpha} = -x_1 \frac{1 + \alpha}{\alpha - 1}$$

since  $\alpha > 1$ , always, for a flow into well.

$$\therefore d = -x_1 \frac{1 + \alpha}{\alpha - 1} \quad \text{or} \quad -x_1 = \frac{\alpha - 1}{\alpha + 1} d$$

and

$$R = x_1 \sqrt{\left(\frac{1 + \alpha}{1 - \alpha}\right)^2 - 1} = \frac{\alpha - 1}{\alpha + 1} \sqrt{\left(\frac{\alpha + 1}{\alpha - 1}\right)^2 - 1} d$$

Recall that

$$\alpha = \exp\left[\frac{4\pi T}{Q} (h_s - h_w)\right] = e^{2\beta}$$

where

$$\beta = \frac{2\pi T}{Q} (h_s - h_w)$$

Thus,

$$\frac{\alpha - 1}{\alpha + 1} = \frac{e^{2\beta} - 1}{e^{2\beta} + 1} = \frac{e^{\beta} - e^{-\beta}}{e^{\beta} + e^{-\beta}} = \tanh \beta$$

and

$$\frac{\alpha + 1}{\alpha - 1} = \coth \beta$$

Hence,

$$\left(\frac{\alpha + 1}{\alpha - 1}\right)^2 = \coth^2 \beta$$

thus,

$$\left(\frac{\alpha + 1}{\alpha - 1}\right)^2 - 1 = \coth^2 \beta - 1 = \operatorname{cosech}^2 \beta$$

$$\therefore -x_1 = d \tanh \beta \quad d = -x_1 \coth \beta$$

$$R = (\tanh \beta) (\operatorname{cosech} \beta) d = \frac{\sinh \beta}{\cosh \beta} \frac{1}{\sinh \beta} d$$

$$= d \operatorname{sech} \beta = R$$

The procedure for obtaining the solution is (Fig. 23):

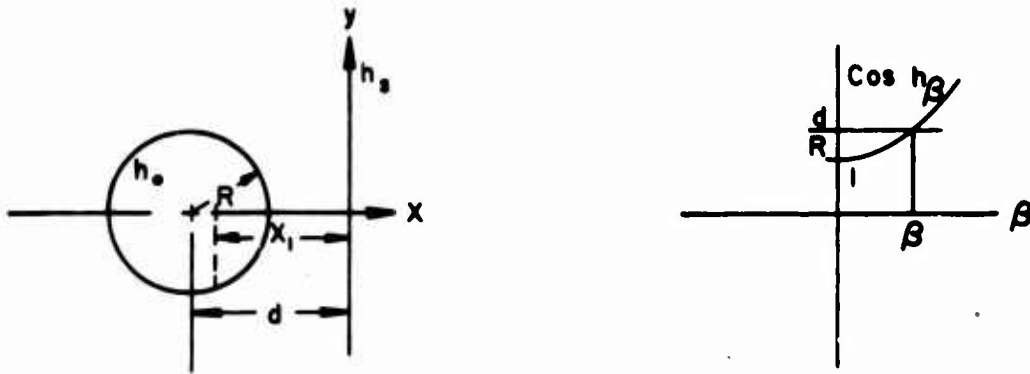

Figure 23

Given  $R$ ,  $d$ ,  $h_s$ ,  $h_o$ , and  $K$ ,  $b$ , etc.

- 1) Obtain  $\beta$  from  $d = (\cosh \beta) R$   
 $d > R$        $\frac{d}{R} = \cosh \beta$
- 2) Obtain  $x_1$  from  $|x_1| = d \tanh \beta$
- 3)  $Q = 2\pi T/\beta (h_s - h_w)$

Solution:

$$\frac{4\pi T}{Q} (h_s - h) = \ln \frac{(x - d \tanh \beta)^2 + y^2}{(x + d \tanh \beta)^2 + y^2}$$

which gives equipotential lines and, by implication, flow lines.

To get filling times, etc.,  $h_w = h_w(t)$

$$Q(t) = \frac{2\pi T}{\cosh^{-1} \frac{d}{R}} (h_s - h_w(t)) = \frac{2\pi T h_s}{\cosh^{-1} \frac{d}{R}} [1 - \zeta(t)]$$

$$\zeta(t) = \frac{h_w(t)}{h_s}$$

One either has

$$\pi R^2 h_w(t) = \int_0^t Q(\tau) d\tau$$

which gives

$$\pi R^2 h_s \zeta(t) = \int_0^t Q(\tau) d\tau$$

or

$$\frac{d\zeta}{dt} = \frac{2T}{R^2 \cosh^{-1} \frac{d}{R}} [1 - \zeta] = C(1 - \zeta)$$

$$C = \text{constant} = \frac{2T}{R^2 \cosh^{-1} \frac{d}{R}}$$

$$\therefore \frac{d\zeta}{1 - \zeta} = C dt$$

Integrating

$$-\log(1 - \zeta) = C t + \text{constant}$$

The condition  $t = 0, \zeta = 0$  implies that the constant = 0

$$\therefore 1 - \zeta = \exp\left(-\frac{2T t}{R^2 \cosh^{-1} \frac{d}{R}}\right)$$

or

$$\frac{h_w(t)}{h_s} = 1 - \exp\left(-\frac{2Tt}{R^2 \cosh^{-1} \frac{d}{R}}\right)$$

and finally,

$$h_w(t) = h_s \left[ 1 - \exp\left(-\frac{2Tt}{R^2 \cosh^{-1} \frac{d}{R}}\right) \right]$$

**BLANK PAGE**

## 5. A QUIESCENT WELL IN A UNIFORM FLOW

If, after the crater is filled, one can assume there is a uniform flow over the well as illustrated in Fig. 24, some fluid will pass through the well, and some fluid will bypass it. If the fluid in the well were radioactive, and if it were assumed that the radioactivity is simply advected, it would be of interest to know the width of the zone of contamination downstream.

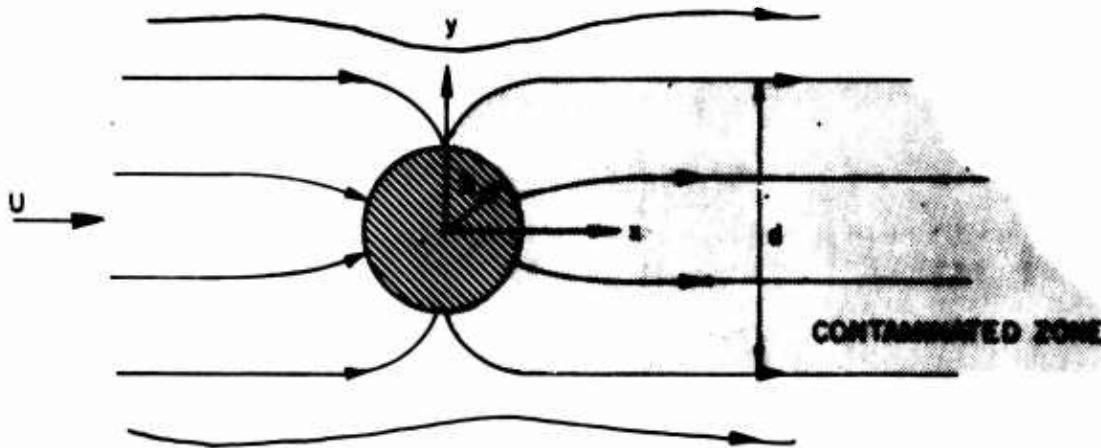

Figure 24

It will be shown in this section that  $d = 4R$ .

With the  $x, y$  coordinate system shown in Fig. 24, the mathematical problem is

$$\nabla^2 h = 0 \text{ for } r = \sqrt{x^2 + y^2} > R$$

$$-k \frac{\partial h}{\partial x} = U \text{ for } r \rightarrow \infty$$

$$h = \text{constant on } r = R$$

Without loss of generality, this constant can be taken to be zero. The solution to this problem can be found easily, and it is

$$h = -\frac{U}{k} \cos \theta \left( r - \frac{R^2}{r} \right)$$

$$r = \sqrt{x^2 + y^2}$$

$$\theta = \tan^{-1} y/x$$

This is the real part of

$$-\frac{U}{k} \left[ z - \frac{R^2}{z} \right] \quad z = x + iy$$

The imaginary part is

$$\phi = -\frac{U}{k} \left[ y + \frac{R^2 y}{x^2 + y^2} \right]$$

The value of  $\phi$  at  $y = R$ ,  $x = 0$  is

$$-\frac{U}{k} 2R$$

Thus, the critical streamline (Fig. 25) is represented by the equation

$$\frac{U}{k} 2R = \frac{U}{k} \left[ y + \frac{R^2 y}{x^2 + y^2} \right]$$

as  $x \rightarrow \infty$ , this implies  $y = 2R = d/2$ . Thus, the thickness of the zone of contamination  $d$  is  $4R$ .

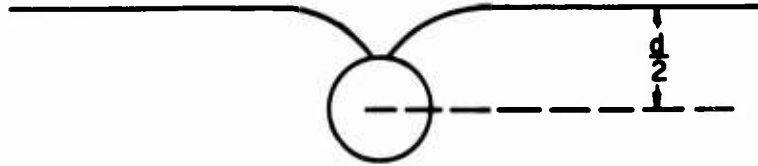

Figure 25

The foregoing analysis is based on nondispersive flow. Actually, the radioactivity would, of course, disperse transversely from the zone of contamination with the result of a larger zone than  $4R$ .

To investigate dispersion in a porous medium, the situation could be idealized and the case of a simple mixing zone (Fig. 26) is investigated.

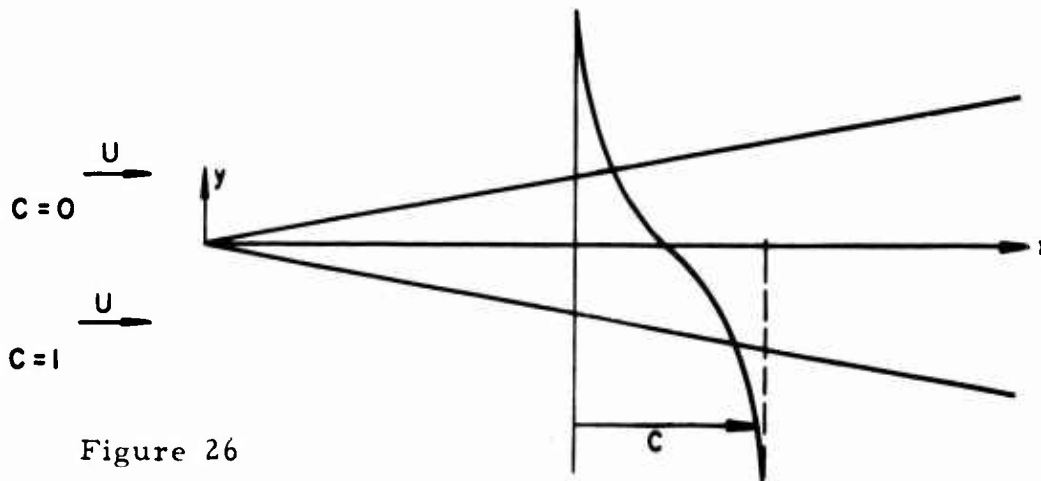

Figure 26

The only variable is the concentration  $C$ , and the governing equation is the dispersion equation

$$u \frac{\partial C}{\partial x} + v \frac{\partial C}{\partial y} = \frac{\partial}{\partial x} \left( D_x \frac{\partial C}{\partial x} \right) + \frac{\partial}{\partial y} \left( D_y \frac{\partial C}{\partial y} \right)$$

which, in the present case, since  $v = 0$  and  $U = u$ , becomes

$$U \frac{\partial C}{\partial x} = \frac{\partial}{\partial x} \left[ D_x \frac{\partial C}{\partial x} \right] + \frac{\partial}{\partial y} \left[ D_y \frac{\partial C}{\partial y} \right]$$

Here  $D_x$  and  $D_y$  are the dispersion coefficients in the longitudinal and transverse directions.

Neglecting the  $D_x$  term compared with the  $D_y$  term on the ground of a boundary layer (BL) assumption, we have

$$\frac{\partial C}{\partial x} = \frac{\partial}{\partial y} \left( \epsilon \frac{\partial C}{\partial y} \right)$$

where  $\epsilon = D_y/U$ . Since  $U$  is constant,  $D_y$  would be expected to be constant also. Hence,  $\epsilon$  is constant. Absorb  $\epsilon$  in  $y$  to obtain

$$\frac{\partial C}{\partial x} = \frac{\partial^2 C}{\partial y^2}$$

BC

$$\begin{aligned} y = \infty, \quad C &= 0 \\ y = -\infty, \quad C &= 1 \\ y = 0, \quad \frac{\partial C}{\partial y} &= 0 \end{aligned} \quad x > 0$$

For a similarity solution, let

$$\eta = (y/\sqrt{x})$$

and  $c = f(\eta)$ ; then

$$\frac{\partial C}{\partial x} = -\frac{1}{2} \frac{y}{x^{3/2}} f'$$

$$\frac{\partial^2 C}{\partial y^2} = f'' \frac{1}{x}$$

Thus, DE becomes

$$\frac{1}{2} \eta f' + f'' = 0$$

and BC becomes

$$f(\infty) = 0 \quad f(-\infty) = 1$$

The solution is  $C = -1/2\sqrt{\pi}$

$$\therefore f(\eta) = + \frac{1}{\sqrt{\pi}} \int_{\eta/2}^{\infty} e^{-z^2} dz$$

This is the standard diffusion type solution and may be found in textbooks. The value of  $D_y$  needs to be estimated. In Ref. 2 a graph shows  $D_y/D$  as a function of  $A_p V/D$  where

$A_p$  = particle radius of the bed material

$V$  = velocity (U in this case)

$D$  = diffusion coefficient (molecular)

For large velocities  $V$ , (or for  $A_p V/D \sim 10$ )  $D_y/D$  is about 5 to 10. Hence,  $D_y$  can be taken to be about  $D$  to  $10D$  for practical purposes.

The similarity variable is

$$\eta/2 = \frac{1}{2} \frac{y}{\sqrt{x} \sqrt{D_y/U}} = \frac{y}{2\sqrt{D_y x/U}} //$$

Let  $y_{90}$  be the  $y$  where  $C = 1/10$

This means

$$f = 1/10 \approx \frac{y_{90}}{2 \sqrt{(D_y/U) x}} \approx 1.64$$

Thus

$$y_{90} \approx 3 \sqrt{D_y/U} \sqrt{x}$$

The mixing zone, therefore, grows like  $\sqrt{x}$  with a proportionality constant

$$\approx 3 \sqrt{10 D_y/U}$$

Applied to the present problem, the flow situation would appear as shown in Fig. 27.

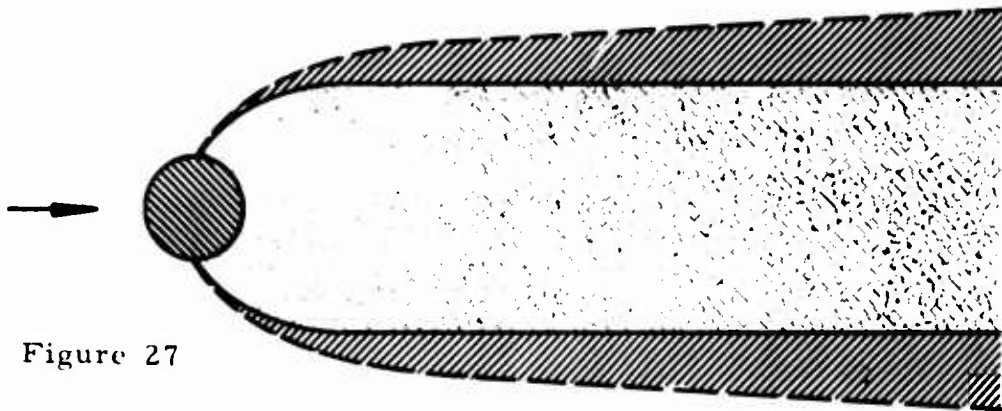

Figure 27

Since the substance undergoing dispersion is radioactive in nature, there is a natural rate of decay. Thus, the equation for dispersion should be modified by a decay term. For those isotopes that decay very slowly in comparison with the motion in the porous medium, the above nondecay analysis should apply. For those isotopes which decay reasonably rapidly, the analysis of the problem should be as shown in Fig. 28.

Still considering the simple case of a mixing zone,



Figure 28

the governing equation is

$$U \frac{\partial C}{\partial x} + kC = D_y \frac{\partial^2 C}{\partial y^2}$$

where it is assumed that the radioactive decay rate is proportional to the concentration with  $k$  as the proportionality constant. Dividing by  $U$ ,

$$\frac{\partial C}{\partial x} + \frac{k}{U} C = \epsilon \frac{\partial^2 C}{\partial y^2}$$

The special case  $\epsilon = 0$  gives the solution

$$C = C_0 \exp\left(-\frac{k}{U} x\right)$$

where  $C_0$  is the concentration at  $x = 0$ . This may be applied to the

core of the zone of contamination in the previous problem. This may now be taken as the boundary condition at  $y \rightarrow -\infty$ .

Nondimensionalizing the variables by

$$C^* = C/C_0, \quad x^* = (k/U) x, \quad y^* = \sqrt{(k/D_y)} y$$

the following equation is obtained

$$\frac{\partial C^*}{\partial x^*} + C^* = \frac{\partial^2 C^*}{\partial y^{*2}}$$

with the boundary conditions

$$C^* \rightarrow 0 \text{ as } y^* \rightarrow \infty, \text{ for } x^* > 0$$

$$C^* \rightarrow e^{-x^*} \text{ as } y^* \rightarrow -\infty, \text{ for } x^* > 0$$

$$C^* \rightarrow 0 \text{ as } x^* \rightarrow 0$$

Let

$$C^* = e^{-x^*} f$$

$$\frac{\partial C^*}{\partial x^*} = -e^{-x^*} f + e^{-x^*} f_{x^*}$$

$$\frac{\partial^2 C^*}{\partial y^{*2}} = e^{-x^*} f_{y^*y^*}$$

$\therefore$  the equation becomes

$$\frac{\partial f}{\partial x^*} - f + f = \frac{\partial^2 f}{\partial y^{*2}}$$

or

$$\frac{\partial f}{\partial x^*} = \frac{\partial^2 f}{\partial y^{*2}}$$

The boundary conditions become

$$\left. \begin{array}{l} f \rightarrow 0 \text{ as } y^* \rightarrow \infty \\ f \rightarrow 1 \text{ as } y^* \rightarrow -\infty \end{array} \right\} x > 0$$

Now note that this is the same problem as the case of nondecay dispersion. Hence, the solution is

$$f = \frac{1}{\sqrt{\pi}} \int_{\eta/2}^{\infty} e^{-z^2} dz$$

Hence,

$$C = C_0 \exp\left(-\frac{k}{U} x\right) \frac{1}{\sqrt{\pi}} \int_{\eta/2}^{\infty} e^{-z^2} dz //$$

## 6. FLOW INTO A WATER SURROUNDED CRATER

In the case of the New Orleans burst, flooding could extend to areas of considerable size, and the water will certainly surround the crater lip. Therefore, the time of filling of the crater would be different from the case of infinite media.

If the Dupuit-Forchheimer assumption is used and initial transient phenomena are neglected, we immediately have the equation for ground-water motion

$$H^2 - h^2 = \frac{Q}{\pi K} \log \frac{r_o}{R}$$

The notations are indicated in Fig. 29, except  $Q$  and  $K$  which are defined in the previous sections to be discharge and permeability.

Another equation which governs the filling of the crater is

$$\int_0^t Q(\tau) d\tau = \pi R^2 h$$

or

$$Q = \pi R^2 \frac{dh}{dt}$$

Combining the equation with the equation of motion, we have

$$\pi R^2 \frac{dh}{dt} = \frac{(H^2 - h^2) \pi k}{\log \frac{r_o}{R}}$$

PROOFING  
PAGE 11ANK

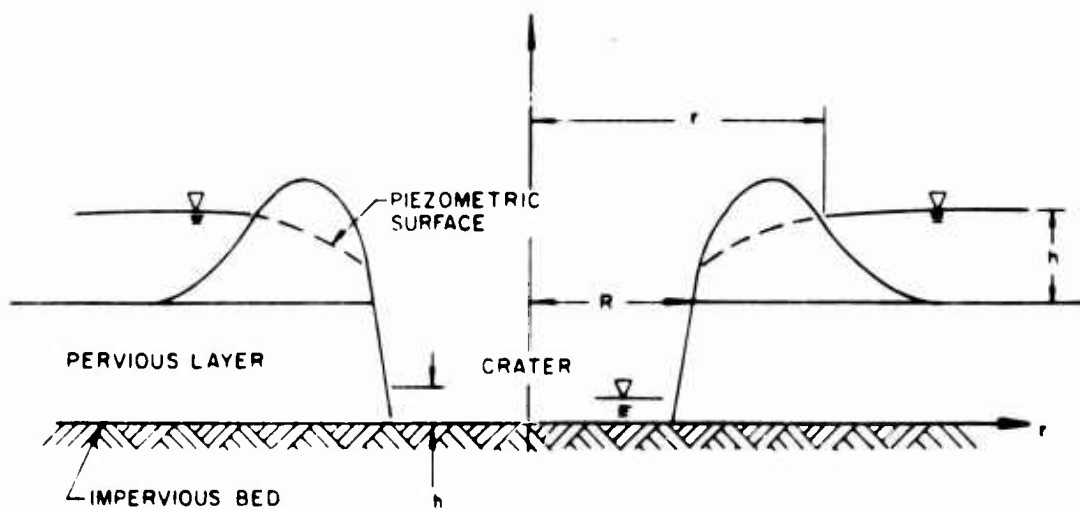

Figure 29

PA-3-9072

or

$$\frac{dh}{H^2 - h^2} = \frac{K dt}{R^2 \log \frac{r_0}{R}}$$

After integrating, we obtain

$$\frac{1}{H} \tanh^{-1} \frac{h}{H} = \frac{Kt}{R^2 \log \frac{r_0}{R}} + c$$

The initial condition,  $h = 0$  when  $t = 0$ , implies  $c = 0$ .

Therefore, one has

$$h = H \tanh \frac{H K t}{R^2 \log \frac{r_0}{R}}$$

PRECEDING  
PAGE BLANK

## 7. REFERENCES

Hantush, M. S., a Chapter in Advances in Hydroscience, Vol. 1, V. T. Chow, Ed., Academic Press, 1965.

Ho, D. V., and Meyer, R. E., "Climb of a Bore on a Sloping Beach," Fluid Mechanics, Vol. 14, 1962.

Lamb, H., Hydrodynamics, Cambridge University Press, 1932.

UNCLASSIFIED

Security Classification

DOCUMENT CONTROL DATA - R&D		
<i>(Security classification of title, body of abstract and indexing annotation must be entered when the overall report is classified)</i>		
1. ORIGINATING ACTIVITY (Corporate author) National Engineering Science Company 711 South Fair Oaks Avenue Pasadena, California 91105		2a. REPORT SECURITY CLASSIFICATION UNCLASSIFIED
		2b. GROUP N/A
3. REPORT TITLE Hydrodynamic Effects of Nuclear Explosions		
4. DESCRIPTIVE NOTES (Type of report and inclusive dates) Volume V - Theoretical Developments		
5. AUTHOR(S) (Last name, first name, initial) Le Méhaute, B. J. ; Koh, R. C. Y. ; Hwang, L. S. ; Mei, C. C. ; and Divoky, D. J.		
6. REPORT DATE June 1966	7a. TOTAL NO OF PAGES 89	7b. NO OF REFS 3
8a. CONTRACT OR GRANT NO. B-70935(4949A-37)-US	9a. ORIGINATOR'S REPORT NUMBER(S) S-244-5	
b. PROJECT NO.		
c. Stanford Research Institute	9b. OTHER REPORT NO(S) (Any other numbers that may be assigned this report)	
d. Civil Defense Technical Office	N/A	
10. AVAILABILITY/LIMITATION NOTICES Distribution of this document is unlimited.		
11. SUPPLEMENTARY NOTES N/A	12. SPONSORING MILITARY ACTIVITY N/A	
13. ABSTRACT This fifth and final volume of the report, "Hydrodynamic Effects of Nuclear Explosions," presents new theoretical developments of two problems. The first is the determination of the waves resulting from the passage of a high-pressure disturbance over the free surface of a body of water. This would occur in the case of a burst on or over land near a shore and is, therefore, of interest to the Five City Study in which three nuclear surface bursts are near rivers or bays.  The second topic is motion of the ground water table induced by a surface burst. This problem is of interest for the determination of the migration of radioactive contaminants and is also applicable to three cities of the Five City Study.		

14. KEY WORDS	LINK A		LINK B		LINK C	
	ROLE	WT	ROLE	WT	ROLE	WT
AIR BURST						
EXPLOSION EFFECTS						
DAMAGE EFFECTS						
FLOODING						
GROUND WATER						
WATER SUPPLY						

INSTRUCTIONS

1. **ORIGINATING ACTIVITY:** Enter the name and address of the contractor, subcontractor, grantee, Department of Defense activity or other organization (*corporate author*) issuing the report.

2a. **REPORT SECURITY CLASSIFICATION:** Enter the overall security classification of the report. Indicate whether "Restricted Data" is included. Marking is to be in accordance with appropriate security regulations.

2b. **GROUP:** Automatic downgrading is specified in DoD Directive 5200.10 and Armed Forces Industrial Manual. Enter the group number. Also, when applicable, show that optional markings have been used for Group 3 and Group 4 as authorized.

3. **REPORT TITLE:** Enter the complete report title in all capital letters. Titles in all cases should be unclassified. If a meaningful title cannot be selected without classification, show title classification in all capitals in parenthesis immediately following the title.

4. **DESCRIPTIVE NOTES:** If appropriate, enter the type of report, e.g., interim, progress, summary, annual, or final. Give the inclusive dates when a specific reporting period is covered.

5. **AUTHOR(S):** Enter the name(s) of author(s) as shown on or in the report. Enter last name, first name, middle initial. If military, show rank and branch of service. The name of the principal author is an absolute minimum requirement.

6. **REPORT DATE:** Enter the date of the report as day, month, year; or month, year. If more than one date appears on the report, use date of publication.

7a. **TOTAL NUMBER OF PAGES:** The total page count should follow normal pagination procedures, i.e., enter the number of pages containing information.

7b. **NUMBER OF REFERENCES:** Enter the total number of references cited in the report.

8a. **CONTRACT OR GRANT NUMBER:** If appropriate, enter the applicable number of the contract or grant under which the report was written.

8b, 8c, & 8d. **PROJECT NUMBER:** Enter the appropriate military department identification, such as project number, subproject number, system numbers, task number, etc.

9a. **ORIGINATOR'S REPORT NUMBER(S):** Enter the official report number by which the document will be identified and controlled by the originating activity. This number must be unique to this report.

9b. **OTHER REPORT NUMBER(S):** If the report has been assigned any other report numbers (*either by the originator or by the sponsor*), also enter this number(s).

10. **AVAILABILITY/LIMITATION NOTICES:** Enter any limitations on further dissemination of the report, other than those imposed by security classification, using standard statements such as:

- (1) "Qualified requesters may obtain copies of this report from DDC."
- (2) "Foreign announcement and dissemination of this report by DDC is not authorized."
- (3) "U. S. Government agencies may obtain copies of this report directly from DDC. Other qualified DDC users shall request through \_\_\_\_\_."
- (4) "U. S. military agencies may obtain copies of this report directly from DDC. Other qualified users shall request through \_\_\_\_\_."
- (5) "All distribution of this report is controlled. Qualified DDC users shall request through \_\_\_\_\_."

If the report has been furnished to the Office of Technical Services, Department of Commerce, for sale to the public, indicate this fact and enter the price, if known.

11. **SUPPLEMENTARY NOTES:** Use for additional explanatory notes.

12. **SPONSORING MILITARY ACTIVITY:** Enter the name of the departmental project office or laboratory sponsoring (*paying for*) the research and development. Include address.

13. **ABSTRACT:** Enter an abstract giving a brief and factual summary of the document indicative of the report, even though it may also appear elsewhere in the body of the technical report. If additional space is required, a continuation sheet shall be attached.

It is highly desirable that the abstract of classified reports be unclassified. Each paragraph of the abstract shall end with an indication of the military security classification of the information in the paragraph, represented as (TS), (S), (C), or (U).

There is no limitation on the length of the abstract. However, the suggested length is from 150 to 225 words.

14. **KEY WORDS:** Key words are technically meaningful terms or short phrases that characterize a report and may be used as index entries for cataloging the report. Key words must be selected so that no security classification is required. Identifiers, such as equipment model designation, trade name, military project code name, geographic location, may be used as key words but will be followed by an indication of technical context. The assignment of links, rules, and weights is optional.